



Technical Specification

SI unit for EtherNet/IP

PRODUCT NAME

EX250-SEN1

Model / Series

SMC Corporation

Table of Contents

Safety Instruction	2
Product Summary	6
<i>SI Unit</i>	
Model Indication Method	7
Part Names	7
Dimensions	8
Mounting/Installation	8
Specifications	11
Wiring	12
Display/Setting	14
EtherNet/IP CONFIGURATION WITH RSLogix5000™	16
<i>Input Block</i>	
Model Indication Method	17
Part Names	17
Dimensions	18
Mounting/Installation	18
Specifications	18
Wiring	19
Display/Setting	20
<i>EX9 Series Output Block/Power Block</i>	
Model Indication Method	21
Part Names	21
Dimensions	22
Mounting/Installation	22
Specifications	23
Wiring	23
Display	26
Option	27
Maintenance procedure	29
Troubleshooting	30

Safety Instructions

This SI unit and this manual contains essential information to prevent possible injury and damage to (users and other people, and property) and to ensure correct handling.

Please confirm understanding the meaning of the following messages (signs) before reading the remaining the text, and always follow the instructions.

Also carefully read the instruction manual for any relevant equipment or apparatus before use.

Indications

IMPORTANT MESSAGES	
Read this manual and follow the instructions. Signal words such as WARNING, CAUTION and NOTE, will be followed by important safety information that must be carefully reviewed.	
▲WARNING	Indicates a potentially hazardous situation which could result in death or serious injury if you do not follow instructions.
▲CAUTION	Indicates a potentially hazardous situation which if not avoided, may result in minor injury or moderate injury.
NOTE	Gives you helpful information.

Operator

- ◆ This manual has been written for those who have knowledge of machinery and apparatuses that use pneumatic equipment and have full knowledge of assembly, operation and maintenance of such equipment.
- ◆ Please carefully read and understand this manual before assembling, operating or performing maintenance on the SI Unit.

Usage Restrictions

- ◆ This product is designed to be used in general equipment for factory automation. Never use this product with equipment or apparatus that directly concerns human lives*¹, or in which a malfunction or failure can cause a great loss.
 - *1: Equipment or apparatus that directly concerns human lives refers to the following:
 - Medical equipment such as life support systems or equipment used in operating rooms
 - Compulsory equipment required by law such as the Fire Prevention Law, Construction Law and etc.
 - Equipment or apparatus that conforms with those mentioned above.
- ◆ Contact our sales department when plans are made for the product to be used for the system*² including equipment that concerns itself with the safety of persons or that seriously affects the public. Such usage requires special consideration*³.
 - *2: A system or equipment that concerns itself with the safety of persons or that seriously affects the public refers to the following:
 - Nuclear reactor control systems in a nuclear power plants, safety protection systems or other systems important for safety in nuclear power facility
 - Driving control system for a mass transportation system, and flight control systems
 - Equipment or apparatuses that comes in contact with foods or beverages
 - *3: Special consideration refer to discussing usage with our engineers to establish a safe system designed as fool-proof, fail-safe, redundant and etc.
- ◆ Special consideration*⁴ should be taken regarding safety or maintainability to prevent a failure or malfunction which can cause a hazard or less. That is likely to occur under certain environmental stress (deterioration).
 - *4: Special consideration means to fully review the equipment or apparatus in design stage and to establish a back up system in advance, such as a redundant system or fail-safe system.

▲WARNING

1. The compatibility of pneumatic equipment is the responsibility of the person who designs the pneumatic system or decides its specifications.
Since the products specified here are used in various operating conditions, their compatibility with the specific pneumatic system must be based on specifications or after analysis and / or tests to meet your specific requirements.
2. Only trained personnel should operate pneumatically operated machinery and equipment.
Compressed air can be dangerous if an operator is unfamiliar with it. Assembly, handling or repair of pneumatic systems should be performed by trained and experienced operators.
3. Do not service machinery / equipment or attempt to remove components until safety is confirmed.
 - Inspection and maintenance of machinery / equipment should only be performed after confirmation of safe locked-out control positions.
 - When equipment is to be removed, confirm the safety process as mentioned above. Cut the supply pressure for the equipment and exhaust all residual compressed air in the system.
 - Before machinery / equipment is re-started, take measures to prevent quick extensions of the cylinder piston rod etc. (Bleed air into the system gradually to create back-pressure.)
4. Contact SMC if the product is to be used in any of the following conditions:
 - Conditions and environments beyond the given specifications, or if product is used outdoors. Installation on equipment in conjunction with atomic energy, railway, air navigation, vehicles, medical equipment, food and beverage, recreation equipment, emergency stop circuits, press applications, or safety equipment.
 - An application which has the possibility of having negative effects on people, property, or animals, requiring special safety analysis.

◆ Do not disassemble, modify (including printed circuit board) or repair.
An injury or failure can result.

◆ Do not operate outside of the specification range.
Fire, malfunction or SI unit damage can result.
Please use it after confirming the specification.

◆ Do not use the product in environments with possible presence of flammable, explosive or corrosion gas.
Otherwise fire, explosion or corrosion can result.
The product is not designed to be explosion proof.

◆ Do not apply voltage exceeding 250V between a lead wire and a metal fitting.
• Pay attention to perform an insulation test because it could damage an insulation of the lead wire and accordingly cause failure and generate heat and smoke.

◆ These instructions must be followed when using the production in an interlocking circuit:
• Provide double interlocking through another system such as mechanical protection
• Check the product regularly to ensure proper operation
Otherwise a malfunction can cause an accident.

◆ These instruction must be followed while in maintenance:
• Turn off the power supply
• Stop the air supply, exhaust the residual pressure and verify that the air is released before performing maintenance work.
Otherwise it can cause injury.

▲CAUTION

◆ Perform proper functional checks after completing maintenance work.
Stop operation when an abnormality is observed or the product is not working properly.
Safety cannot be secured due to unexpected malfunctions.

NOTE

- ◆ Follow the instructions given below when handling reduced-wiring system:
Or it will have a risk of being damaged and operating failure.
- ◆ The instructions on selection (installation, wiring, environment of use, adjustment, operation and maintenance) described below must also be followed.

*Product specifications

- The direct-current power supply to combine should be UL authorization power supply.

(1) Limited voltage current circuit in accordance with UL508

A circuit which power is supplied by secondary coil of a transformer that meets the following conditions

- Maximum voltage (with no load) : less than 30Vrms (42.4V peak)
- Maximum current : (1) less than 8A(including when short circuited)
- (2) limited by circuit protector (such as fuse) with the following ratings

No load voltage (V peak)	Max. current rating (A)
0 to 20 [V]	5.0
Above 20 to 30 [V]	100 / peak voltage

(2) A circuit using max. 30Vrms or less (42.4V peak), which power is supplied by Class-2 power supply unit in accordance with UL1310 or UL1585

- Operate reduced-wiring system with the specified voltage.
Operation with a voltage beyond specifications could cause malfunction or damage of the unit.
- Reserve a space for maintenance
Be sure to keep a space for maintenance when designing layout of the unit.
- Do not remove nameplate.
Otherwise maintenance error and misreading of an operation manual could cause damage or malfunction.
It may also result in nonconformity to safety standards.

◆ Precautions on handling

*Installation

- Do not drop, hit or apply excessive shock to the unit.
Otherwise the unit could be damaged so much as to result in.
- Follow the specified tightening torque.
Excessive tightening torque can break screws.
The screw should be tighten with the specified torque, otherwise IP40 protection can not be guaranteed.

*Wiring (including plugging in/out of connector)

- Do not bend the cables or apply excessive force to them by pulling or placing heavy load.
Wiring subject to bending or tensile stress could cause the cables to break.
- Connect wires and cables correctly.
Incorrect could wiring break the reduced-wiring system to its extent.
- Do not connect wires while the power is supplied.
Otherwise it can break the reduced-wiring system or I/O devices could be damaged or malfunction.
- Do not connect power cable or high-voltage cable in the same wiring route as the unit.
Otherwise the wires to the reduced-wiring system can be interrupted with noise or induced surge voltage from power lines or high-voltage lines and malfunction could be caused.
Separate wiring of the unit and each I/O device from that of power line and high voltage line.

- Verify the insulation of wiring.
Insulation failure (interference with other circuit, poor insulation between terminals and etc.) could introduce excessive voltage or current to the reduced-wiring system or each I/O device and damage them.
- Separate power line for solenoid valves from power line for input and control unit.
Otherwise wires can be interrupted with noise or induced surge voltage causing malfunction.
- Take proper measurements such as noise filter against noise when the reduced-wiring system is incorporated in equipment or devices.
Otherwise contamination with noise can cause malfunction.

*Environment

- Select an operation environment according to enclosure. (IP40)
- Take sufficient shielding measures when the unit is installed.
Insufficient measures could cause malfunction or failure.
Verify the effect of the measures after incorporation of the unit in equipment or devices:
 - (1) A place where noise due to static electricity is generated
 - (2) A place where electric field strength is high
 - (3) A place where there is radioactive irradiation
 - (4) A place near power line
- Do not use the unit near by a place where electric surge is generated.
Internal circuit elements of the reduced-wiring system can deteriorate or break when equipment generating a large surge (electromagnetic lifter, high frequency induction furnace, motor, etc.) is located near the reduced-wiring system. Provide surge preventives, and avoid interference with line for the equipment.
- Use the reduced-wiring system equipped with surge absorber when a surge-generating load such as solenoid valve is driven directly.
Direct drive of a load generating surge voltage can damage reduced wiring system.
- Prevent foreign matter such as remnant of wires from entering the unit.
Take proper measures for the remnant not to enter the reduced-wiring system in order to prevent failure or malfunction.
- Do not expose the reduced-wiring system to vibration and impact.
Otherwise failure or malfunction could be caused.
- Keep the specified ambient temperature range.
Otherwise malfunction could be caused.
Do not use reduced-wiring system in a place where temperature suddenly changes even within the specified range.
- Do not expose the reduced-wiring system to heat radiation from a heat source located nearby.
Malfunction could be caused.

*Adjustment and Operation

- Use precision screwdriver with for small flat blade for setting Dip switch.

*Maintenance

- Perform maintenance and check regularly.
Otherwise an unexpected malfunction of components could of the unit occur due to a malfunction of the whole unit.
- Perform a proper functional check.
Stop operation when an abnormality is observed such that the device doesn't work properly.
Otherwise an unexpected malfunction of the unit component can occur.
- Do not use solvents such as benzene, thinner or other to clean the reduced-wiring system.
They could damage the surface of the body and erase the indication on the body.
Use a soft cloth to remove stains. For heavy stains, use a cloth soaked with diluted neutral detergent and fully squeezed, then wipe up the stains again with a dry cloth.

Product summary

System configuration general

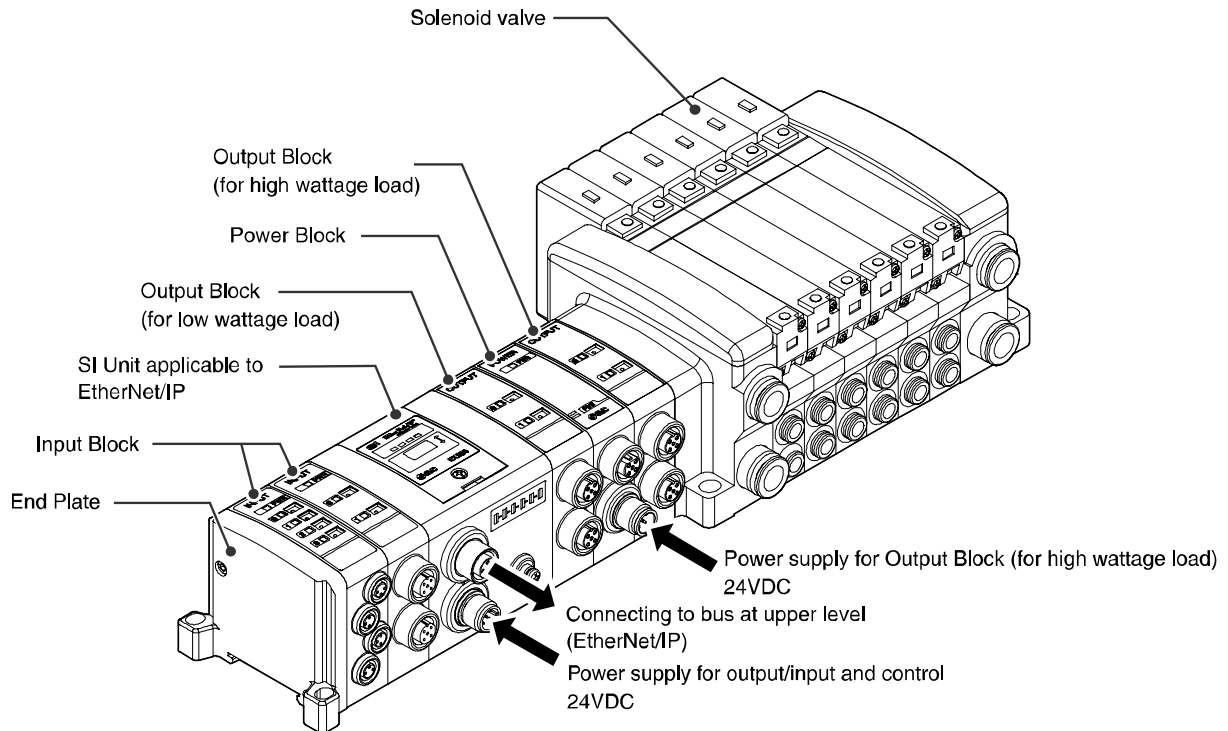

This system realizes reduced wiring between the input and output equipment by connecting to EtherNet/IP. EtherNet/IP and the input and output equipment communicates through the SI Unit.

Up to 32 Inputs can be connected to the SI Unit using Input Blocks.

Up to 32 Outputs^{Note)} from combined EX9 Output Blocks and Valve manifolds can be connected to the SI Unit.

Note) The maximum output point is 24 when the Power Block is connected.

Terms definition

Terms	Definition
DHCP	A protocol to automatically set the information to be registered in individual equipment connected with a TCP/IP network in order to use the network. This includes the IP address.
EtherNet/IP	Open fieldbus for factory automation. This is a protocol that integrates the DeviceNet communication protocol (CIP: Common Industrial Protocol) into EtherNet or TCP/IP. Currently, it is popular in the US and is spreading to Europe.
IP address	A 32 bit sequence of numbers assigned to identify individual devices connected to a network. All devices connected to the network are given individual IP addresses.
MAC address	A number unique to each device connected to EtherNet.
MS	Abbreviation of "module status". It shows whether the power supply of SI unit is turned on and the normal operation is available.
NS	Abbreviation of "network status". It shows the status of EtherNet/IP communication.
SI unit	An abbreviation of serial interface. It sends and receives data by bit through a couple of signal lines, convert it to parallel and correspondingly control connected load. (A serial-to parallel converting unit.)
Half duplex	Communication method by sending and receiving alternately for bilateral communication.
Full duplex	Communication method by sending and receiving simultaneously for bilateral communication.
100BASE-TX	Standard of LAN transmission route with a transmission speed of 100Mbps.

SI Unit

Model Indication Method

EX250 – SEN1

• Communication protocol

EN1	EtherNet/IP
-----	-------------

Part Names

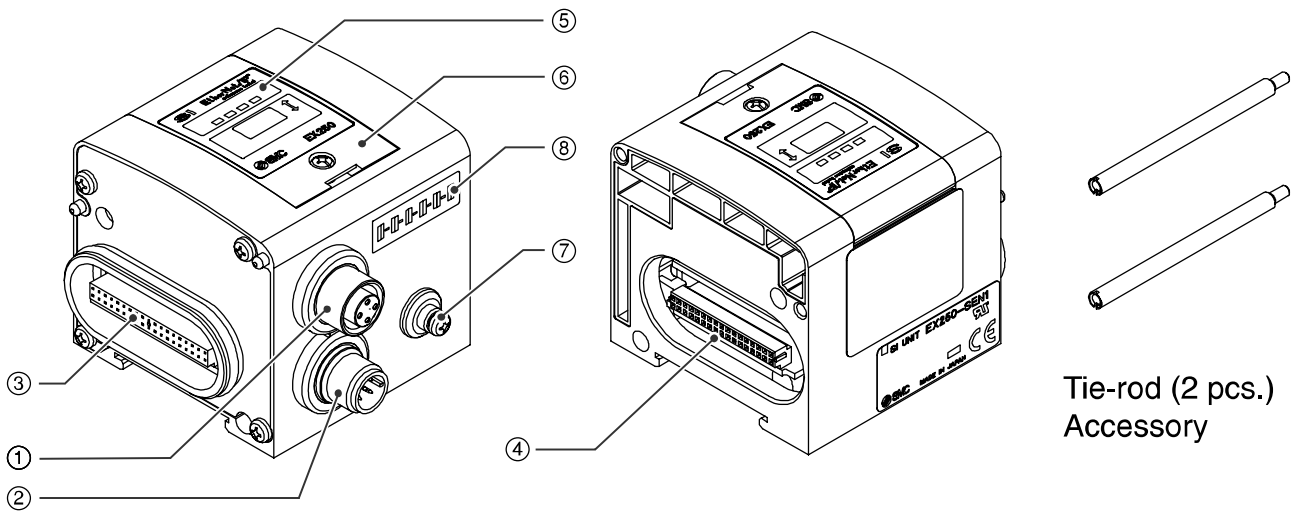

No.	Part names	Application
1	Communication connector	Connect with EtherNet/IP line. ^{Note1)}
2	Power supply connector	Supplies power to the solenoid valve, the Output Block, SI Unit and the Input Block. ^{Note1)}
3	Input Block connector	Connects the Input Block.
4	Output Block connector	Connects the solenoid valve, Output Block and etc.
5	Display	LED display shows the SI Unit status. ^{Note2)}
6	Switch protective cover	Display the power supply status and communication status with PLC. ^{Note2)}
7	Ground terminal	Used for grounding.
8	MAC address	A unique MAC address of 12 hexadecimal number digits to each SI Unit.

Note1 : For wiring method, refer to subsection "Wiring" (page 12) in this Technical Specification.

Note2 : For display and setting method, refer to subsection "Display/Setting" (page 14) in this Technical Specification.

Dimensions (unit: mm)

SI Unit body

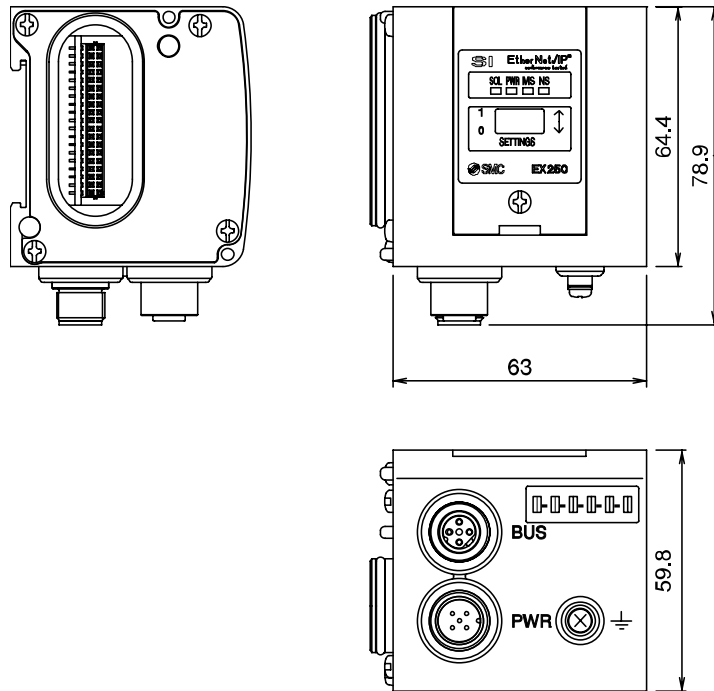

Mounting/Installation

How to assemble / disassemble units.

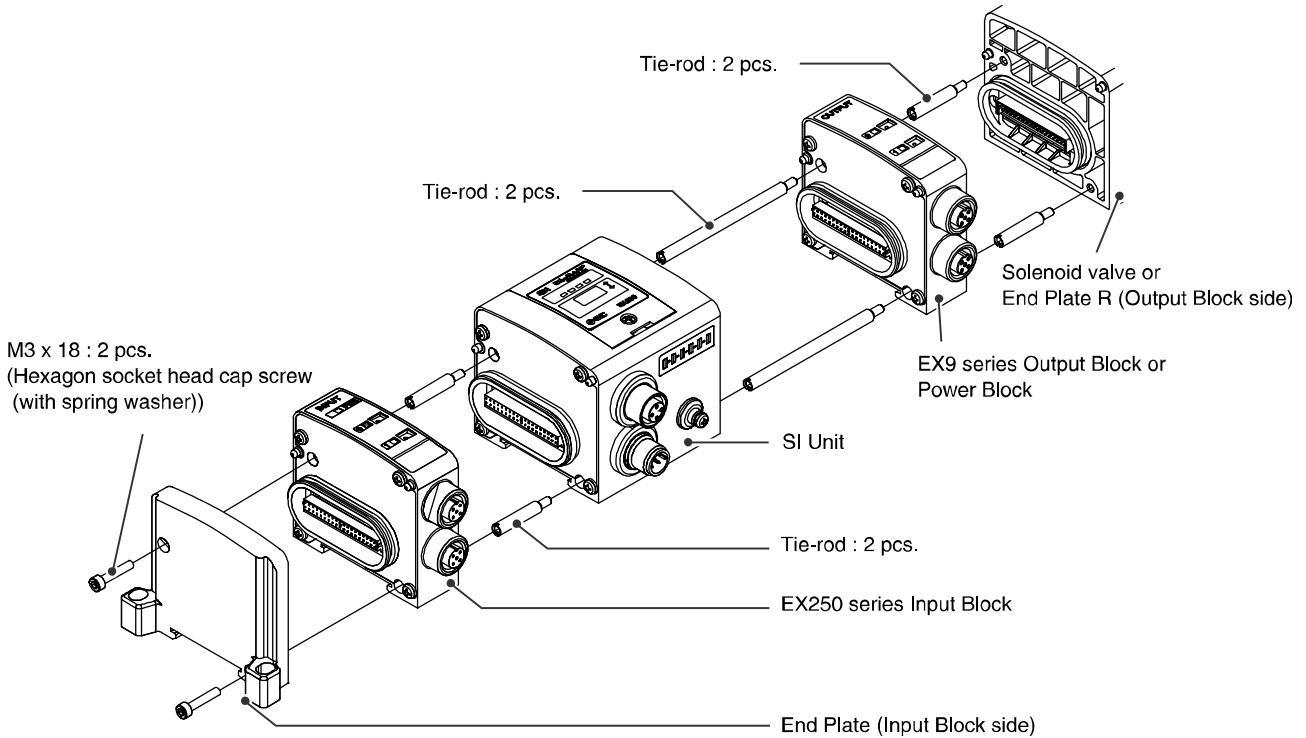

NOTE

Hold the SI Unit and the Input / Output Block in order to have no clearance between them while tightening the bolt.
Be sure to tighten bolt by specified tightening torque. (Tightening torque : 0.6Nm)

Layout of the Input Block

- Position the Input Block on the left side of the SI Unit.

Layout of the EX9 series Output Block / Power Block

Position the Output Block / Power Block on the right side of the SI Unit and between the SI Unit and solenoid valve or End Plate R (on the Output Block side).

1) Output Block for high wattage load

- The Output Block for high wattage load cannot be used independently. Be sure to combine with the Power Block for use.

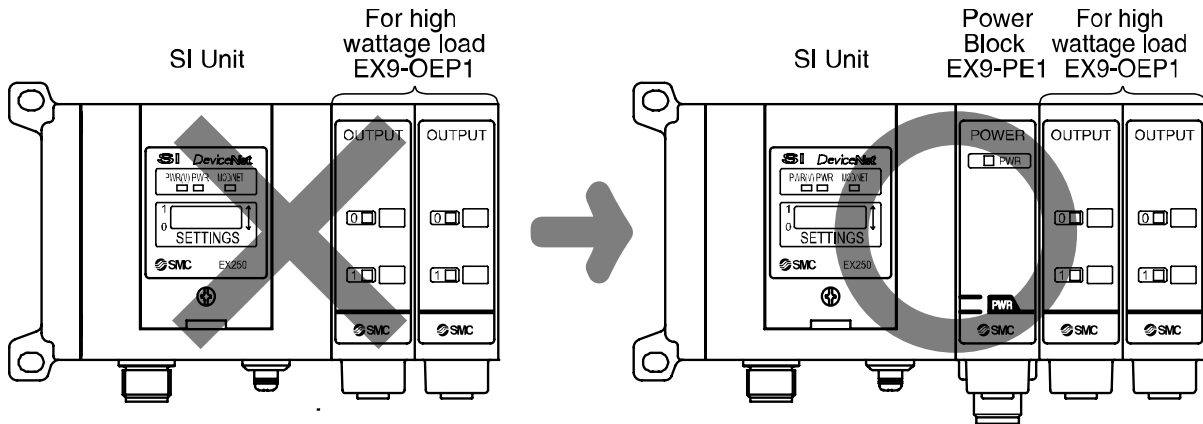

2) Position of Output Block for high wattage load

- The Output Block for high wattage load cannot be mounted at the place nearer to the SI Unit than the Power Block. However, that place is acceptable if the Power Block is located between SI Unit and the Output Block for high wattage load.

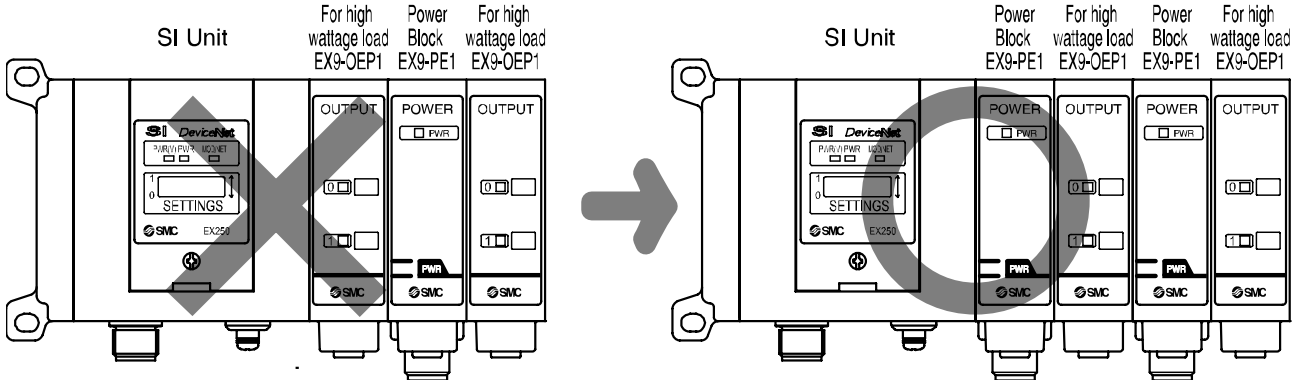

3) Output Block for low wattage load

- The Output Block for low wattage load cannot be mounted at the right side of the Power Block. Mount to the place nearer to the SI Unit than the Power Block.

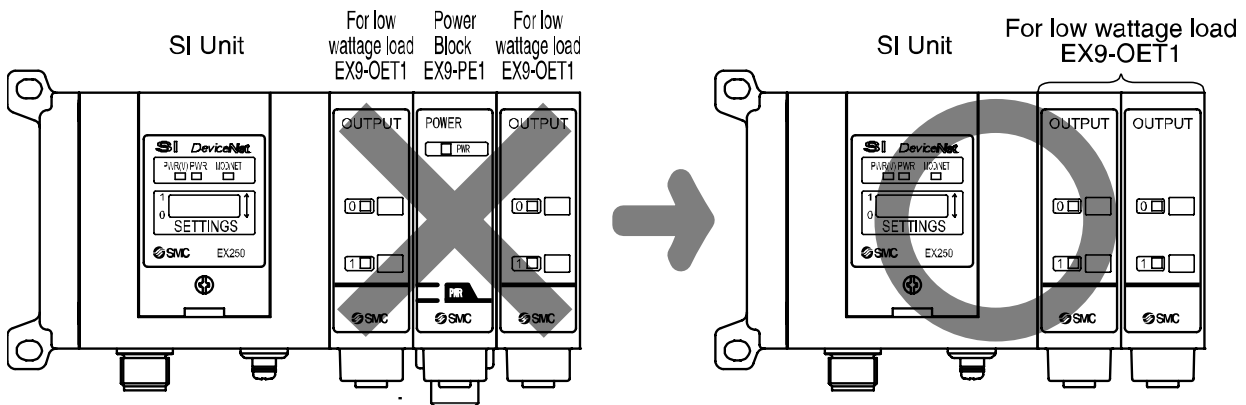

Position of End Plate

- Be sure to connect the End Plate (on the Input Block side) at the left end of the manifold.
- When the valve is not connected, be sure to connect the End Plate R (on the Output Block side) at the right end of the manifold.

Installation example Dimensions with solenoid valves unconnected [Unit: mm]

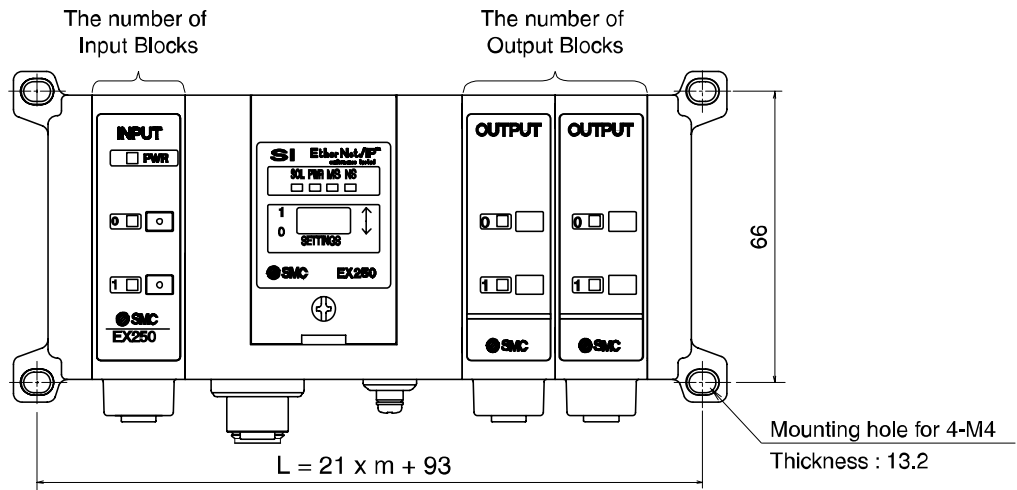

* The number of Input Blocks + The number of Output Blocks + The number of Power Blocks : m

L \ m	1	2	3	4	5	6	7	8	9	10
L	114	135	156	177	198	219	240	261	282	303

[mm]

* Each dimension shows the unit without solenoid valves connected and with an End Plate R (on the Output Block side) connected. Standard settings of L dimensions are with 10 or less m blocks. Ask SMC sales for the setting with over 10 blocks mounted.

Refer to the individual specifications for the dimensions when the solenoid valves are connected.

Specifications

Basic specifications

Rated voltage	24VDC
Range of power supply voltage	Power supply for input and control : 24VDC±10% Power supply for output : 24VDC+10%/-5%
Rated current	Power supply for input and control : Max. 1.1A <div style="border: 1px solid black; padding: 2px; display: inline-block;"> Inside SI Unit : 0.1A Input device : 1A </div> Power supply for output : Max. 2A
Number of input/output points	Input point : Max. 32/Output point : Max. 32 *
Output type	PNP output (-COM.)

* The maximum output point is 24 when the Power Block is connected.

Higher-level bus

Protocol	Ethernet (IEEE802.3)
Media	100BASE-TX
Communication speed	10M/100Mbps (Automatic selection or manual setting)
Max. segment length	100m (328ft)
Max. transceiver number	2 (per segment)
Communication method	Full duplex/Half duplex (automatic selection or manual setting)
Fieldbus protocol	EtherNet/IP™
I/O message	Input : Data length 6 byte, Instance 100. Output : Data length 4 byte, Instance 150.
IP address setting range	192.168.0.1 to 192.168.0.14 (Setting by an internal switch) Or optional setting by the DHCP server
Device information	Vendor ID : 7 (SMC Corp.) Product type : 12 (communication adapter) Product code : 107

I/O mapping

Input area mapping

Offset (word)	Input data																
	MSB								LSB								
	15								0								
0	15	14	13	12	11	10	9	8	7	6	5	4	3	2	1	0	Sensor input area
1	31	30	29	28	27	26	25	24	23	22	21	20	19	18	17	16	
2	L	L	L	L	SP	DI	L	L	L	L	L	L	L	L	L	L	

L : Fixed to Low

Status input area

Diagnostic (Status input area)

Item	Status	Condition	
SP	Solenoid power supply status	0	No supply voltage
		1	Supply voltage OK
DI	Status of sensor power supply	0	Short circuit
		1	Normal

Output area mapping

Offset (word)	Output data															
	MSB								LSB							
	15								0							
0	15	14	13	12	11	10	9	8	7	6	5	4	3	2	1	0
1	31	30	29	28	27	26	25	24	23	22	21	20	19	18	17	16

Wiring

1. Communication wiring

Connect the Ethernet Communication Cable to the communication connector of SI Unit.

Cable connection

- 1) Aligning the key groove with the communication connector (4-pin, socket) of SI Unit, plug the Ethernet Communication Cable (plug).
- 2) Tighten the lock nut on cable side by turning it clockwise by hand.
- 3) Confirm that the connector portion does not move.

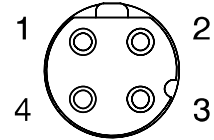
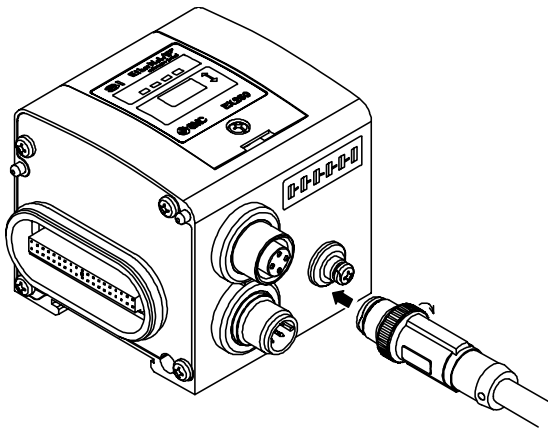

Socket connector pin layout

Pin layout and connection diagram of Ethernet Communication Cable

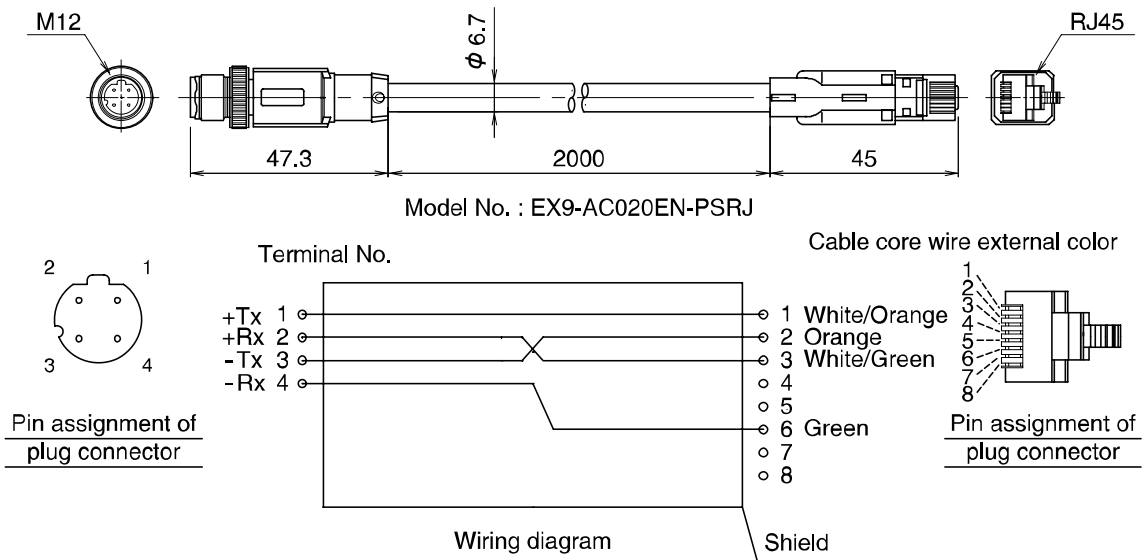

Cable specifications	
Core wire	AWG 26
Sheath color	Blue green

Refer to "Media Planning and Installation Manual" of ODVA for detail of Wiring.

2. Power supply wiring

Connect the Power Supply Cable to the power supply connector of SI Unit.

When selecting the power supply, refer to "Precautions on handling" (page 4) in this Technical Specification.

Cable connection

- 1) Aligning the key groove with the power supply connector (plug) of SI Unit, plug the Power Supply Cable (socket).
- 2) Tighten the lock nut on cable side by turning it clockwise by hand.
- 3) Confirm that the connector portion does not move.

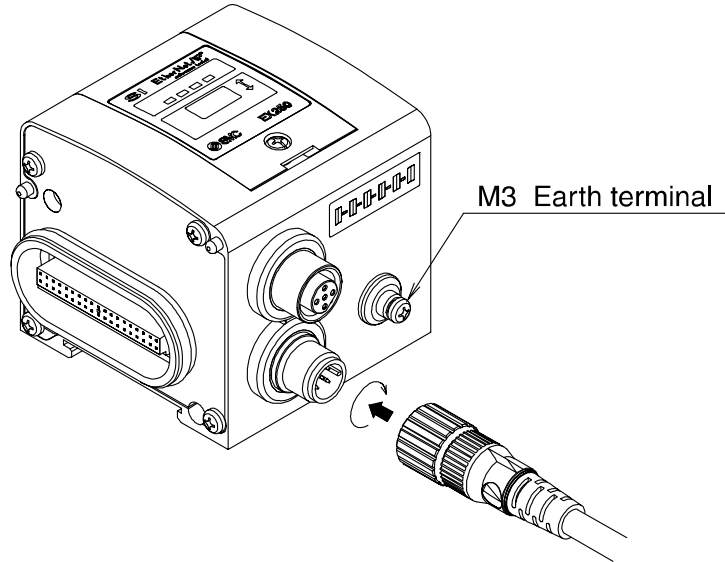

Pin layout and connection diagram of power supply connector cable for (unit : mm)

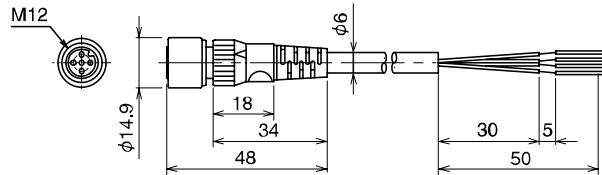

Model No. : EX500-AP□-S

Pin No.	Cable color: Signal name
1	Brown : 24VDC +10%/-5% (for solenoid valves/output)
2	White : 0V (for solenoid valves/output)
3	Blue : 24VDC \pm 10% (for input and control)
4	Black : 0V (for input and control)
5	Grey : Earth

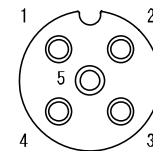

Socket connector pin layout

NOTE

Ground the Earth terminal with the ground resistance at 100 ohm or less. Make the pin No.5 of the power supply connector ungrounded, and ground at one point.

Connecting one or two power supplies to SI Unit.

Both single power supply and two power supply systems can be adopted, however, the wiring shall be made separately (for solenoid valves/output and for input and control) for either system.

A. Two power supplies

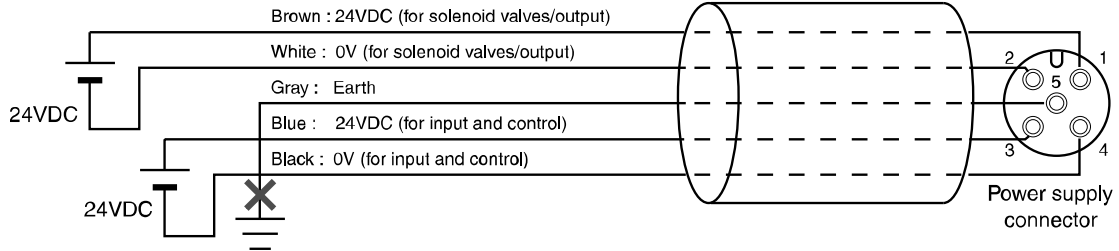

B. Single power supply

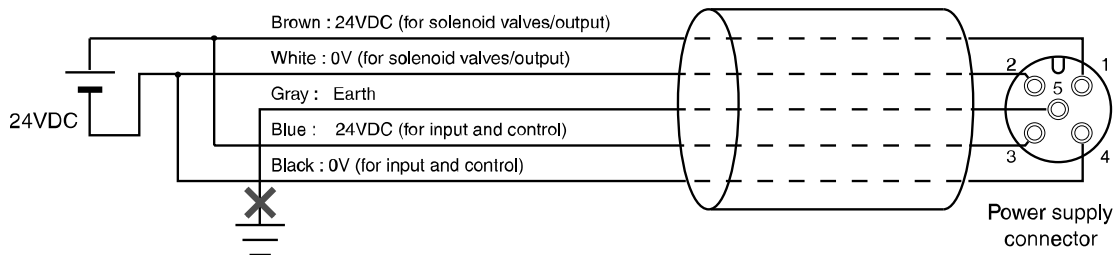

Display/Setting

Settings for display

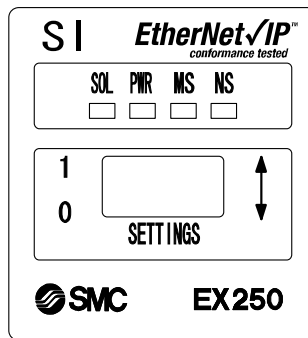

Display	Contents	
SOL	OFF	The power supply for solenoids is insufficient
	Green light ON	The power supply for solenoids is normal
PWR	OFF	The power supply for input and control is insufficient
	Green light ON	The power supply for input and control is normal
MS	OFF	The power supply for control is OFF
	Green light ON	Operating normally
	Green flashing	Setting error (Device has not been configured)
	Red flashing	Recoverable internal error
NS	Red light ON	Unrecoverable internal error
	OFF	The power supply for control is OFF or IP address not set
	Green flashing	EtherNet/IP-level communication not established
	Green light ON	Multiple EtherNet/IP-level communications established
	Red flashing	Multiple EtherNet/IP-level communications time out
	Red light ON	IP address duplicated

Switch setting

Open the switch protective cover and set the switches with a sharp-pointed watchmakers screwdriver etc.

NOTE

1. Be sure to turn off the power before setting the switches.
2. Be sure to set these switches before use.
3. After setting the switch, close the switch protective cover and tighten the screws with the proper tightening torque. (Tightening torque : 0.6Nm)

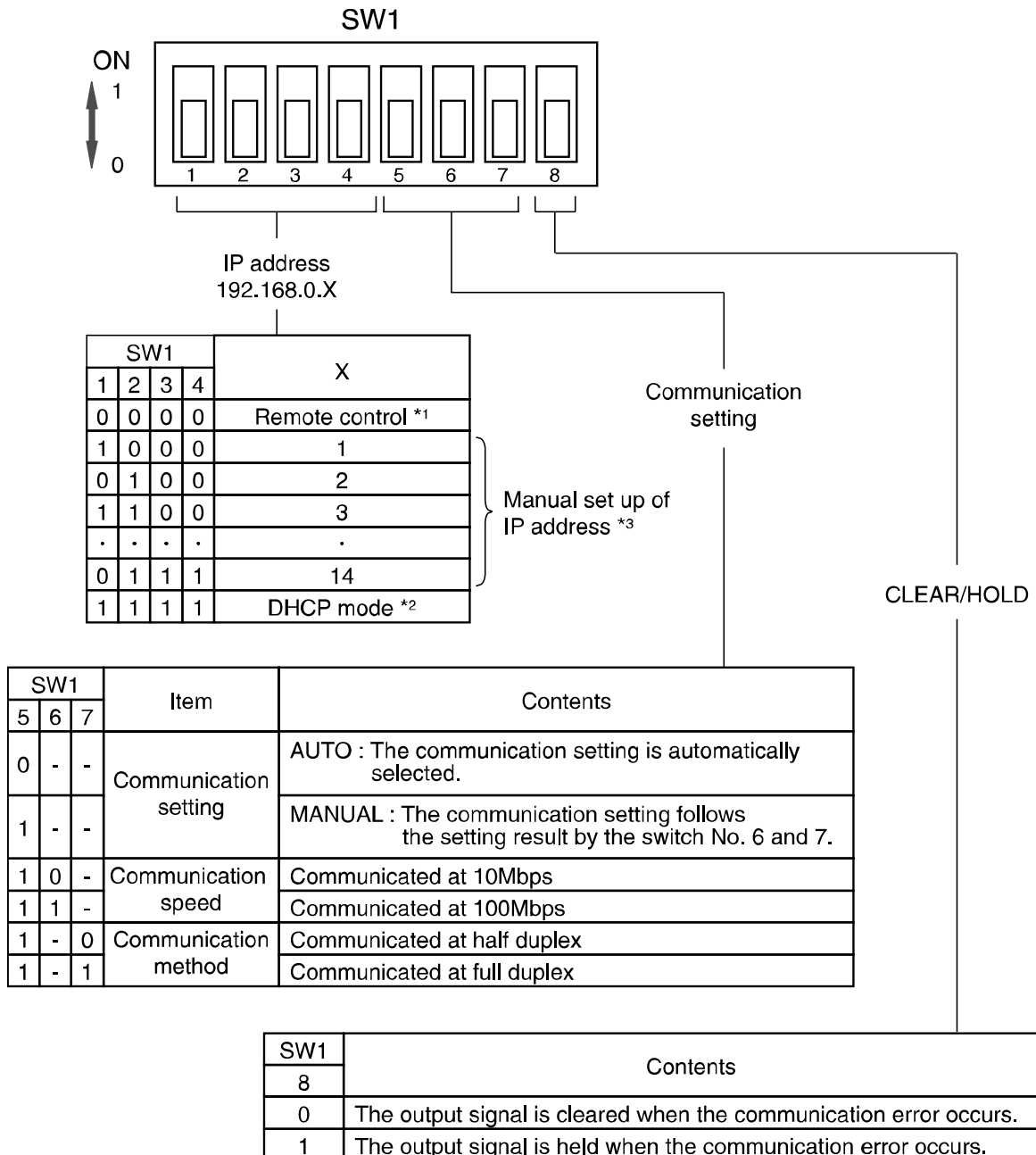

***1 : Remote control (SW1 Dip switches 1-4 off)**

SMC's EX250 SI Unit will respond to the following Rockwell Automation BOOTP/DHCP Server commands.

Enable DHCP

Selecting this function will enable the EX250 SI Unit to retrieve its boot information from the BOOTP/DHCP Server. If DHCP is enabled the EX250 SI Unit will retrieve its boot information during the next power up.

Disable BOOTP/DHCP

Selecting this function will disable the EX250 to retrieve its boot information from the BOOTP/DHCP Server, and causes the EX250 to retain its current configuration during the next power up.

***2 : DHCP Mode (SW1 Dip switches 1-4 on)**

The IP address is acquired via DHCP Server. The IP address is not saved and lost if the power to the EX250 unit is cycled.

***3 : Hardware Addressing**

The IP address range is 192.168.0.1-192.168.0.14.

Default settings

At the time of factory shipment, the product is in "Remote Control Mode" and set to "Enable DHCP".

NOTE
If the stored IP address of an EX250 is not known, please go to the "DHCP Mode" section.

EtherNet/IP CONFIGURATION WITH RSLogix5000™

When setting up the node with RSLogix5000™, specific values must be entered for the assembly instance with regards to Input, Output and Configuration.

Please see the diagram below for a Rockwell Automation's RSLogix5000™ programming software example.

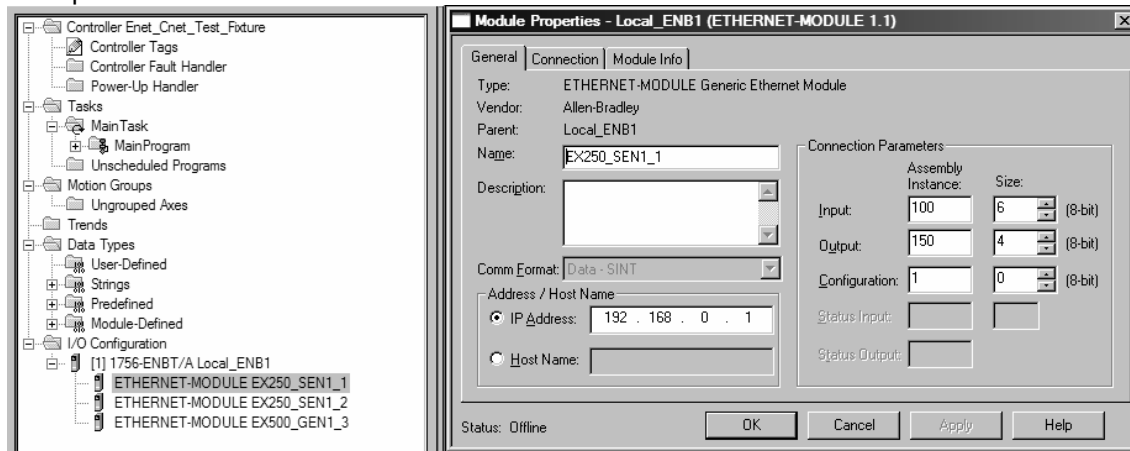

*PLC software RSLogix5000™ manufactured by Rockwell Automation is shown above. RSLogix5000™ is a registered trademark of Rockwell Automation.

Connection Parameter

Assembly Instance values :

Description	Decimal	
Comm Format	"Data-INT"	"Data-SINT"
Input	100	100
Output	150	150
Configuration	1	1

Size :

Description	Size	
Comm Format	"Data-INT"	"Data-SINT"
Input	3 words	6 bytes
Output	2 words	4 bytes
Configuration	0 word	0 byte

Input Block

Model Indication Method

Input Block

Model indication method

EX250 – IE

● Block type

1	Input points : 2, M12 connector (2pcs.)
2	Input points : 4, M12 connector (2pcs.)
3	Input points : 4, M8 connector (4pcs.)

Part Names

EX250-IE1

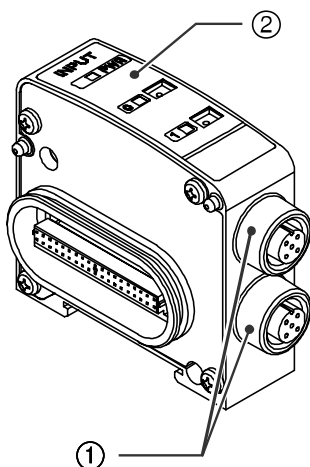

EX250-IE2

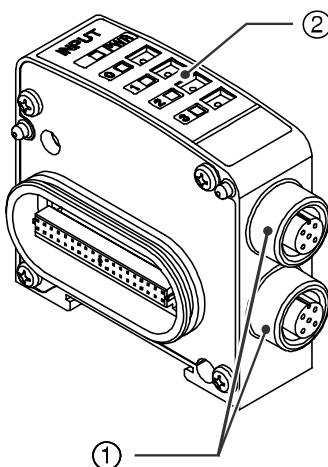

EX250-IE3

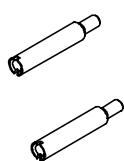
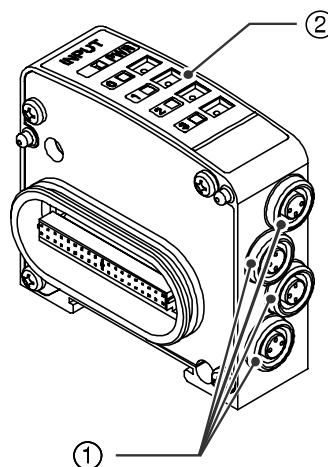

Tie-rod (2 pcs.)
Accessory

No.	Part names	Application
1	Input equipment connector	Connects the input equipment such as sensor, etc. ^{Note1)}
2	Operation display LED	Displays the power source and input status. ^{Note2)}

Note1 : For wiring method, refer to subsection "Wiring" (page 19) of section "Input Block" in this Technical Specification.

Note2 : For display and setting, refer to "Display/Setting" (page 20) in section "Input Block" in this Technical Specification.

Dimensions (unit: mm)

EX250-IE1/2

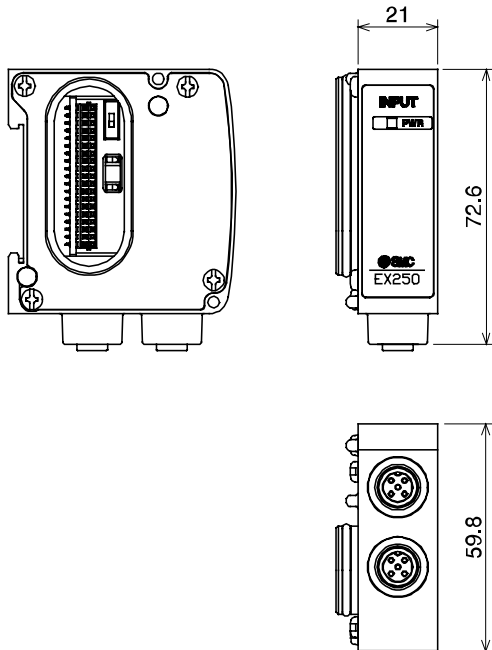

EX250-IE3

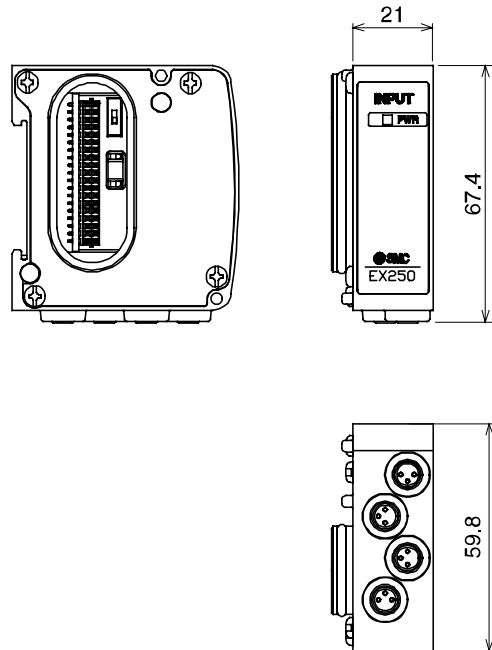

Mounting/Installation

Refer to subsection "Mounting/Installation" (page 8) in this Technical Specification.

Specifications

Applicable sensor	Current source type(PNP input) Current sink type(NPN input) *Selected with a switch.	
Rated voltage	24VDC (It can have a voltage drop for 1V at max. to the power source voltage of the SI Unit.)	
Logical "1" input voltage VH	11 to 30V	
Logical "0" input voltage VL	-3 to +5V	
Logical "1" input current IH	8mA Typ.	
Connection of 2-wire sensor	Possible	
Logical "0" input current IL	Max.2.5mA	
Input delay time	3msec. Typ.	
Supply current to sensor	Max. 120mA / Input Block	
Connector type of the input equipment	IE1/2	M12 connector (4 pin, plug or 5 pin, plug)
	IE3	M8 connector (3 pin, plug)

Wiring

1. Input wiring

Cable wiring

EX250-IE1/2/3

- 1) Aligning the key groove with the input connector (socket) of Input Block, plug in the cable (plug).
- 2) Tighten the lock nut on cable side by turning it clockwise by hand.
- 3) Confirm that the connector does not move.

EX250-IE1/2

EX250-IE3

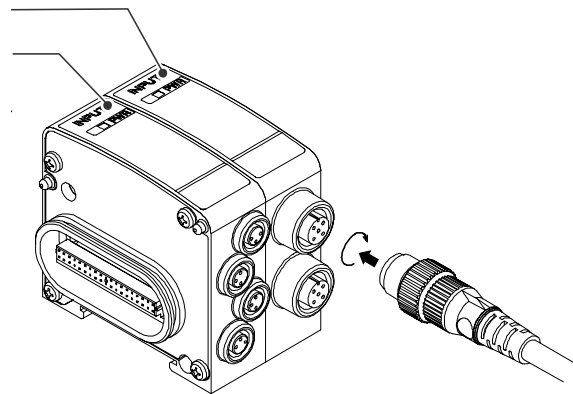

Input connector pin layout

EX250-IE1 (M12 connector, 5 pin, Socket)	
<p>① Power supply (24VDC) ③ Power supply (0V) ⑤ Earth</p> <p>Input connector "0" Input connector "1"</p>	<p>Input No.1 *1 Input No.0 NC *2</p>
<p>*1) Input No.1 is connected to the pin No.2 of the input connector "0", 2 input signals can be directly input from the input connector "0". *2) NC : Not connected</p>	
EX250-IE2 (M12 connector, 5 pin, Socket)	
<p>① Power supply (24VDC) ③ Power supply (0V) ⑤ Earth</p>	<p>Input No.1 Input No.0 Input No.3 Input No.2</p>
EX250-IE3 (M8 connector, 3 pin, Socket)	
<p>① Power supply (24VDC) ③ Power supply (0V) ④ Input</p>	<p>Input connector "0" Input connector "1" Input connector "2" Input connector "3"</p>

Be sure to check the specifications of the input signal when wiring the sensor. It may cause the malfunction. Mind the position of the mounting key when selecting the sensor.

NOTE

Mount a Waterproof Cap on each unused connector of Input Block. The proper use of Waterproof Cap can achieve IP67 Enclosure. (Tightening torque : 0.1Nm for M12)
For Waterproof Cap, refer to "Option" (page 27) in this Technical Specification.

Correlation between input number and Input Block

The total number of input and output blocks can not exceed 10.
The maximum input point is 32.

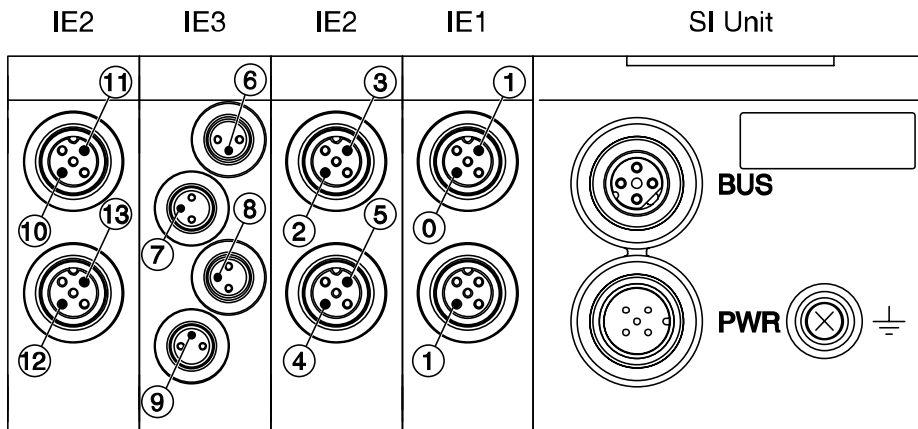

The input number is 1, 2 ...32 from the SI Unit side.

Display/Setting

Display

EX250-IE1	EX250-IE2/IE3

Display	Description	
PWR	Lights up	Power supply for sensor is ON.
	Off	Power supply for sensor is OFF.
0, 1, 2, 3	Lights up	Sensor signal input corresponding to the number is ON. (Logic "1")
	Off	Sensor signal input corresponding to the number is OFF. (Logic "0")

Switch setting

- Applicable sensor to the Input Block can be switched to NPN/PNP.
- Remove the Input Block according to the "Mounting/Installation" (page 8) in this Technical Specification, then set up the switch with a sharp-pointed watchmakers screw driver etc.
- Install the Input Block after the setting according to "Mounting/Installation" (page 8) in this Technical Specification.

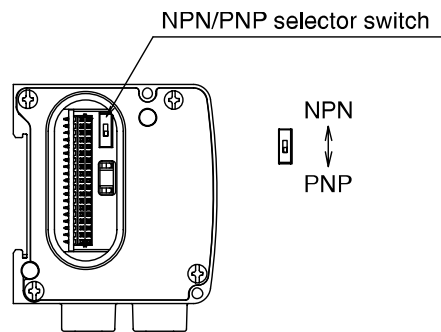

EX9 Series Output Block/Power Block

Model Indication Method

The EX9 series General Purpose Output Block is the unit to operate various outputs (solenoid valve, relay, etc.) in combination with valve and SI Unit.

There are two types ---- one type is for low wattage load (EX9-OET1) receiving power supply from SI Unit, and the other type is for high wattage load (EX9-OEP1) receiving power supply from an external source. ^(NOTE)

The type for high wattage load is used in combination with the Power Block (EX9-PE1) connected with external power supply.

As the low wattage load type is powered from SI Unit, the wattage of load is limited to 1.5W ^(NOTE). For a load up to 12W, use the Power Block and the high wattage load type.

NOTE

+COM. type EX9-OET/P2 cannot be connected to EX250-SEN1.

Output Block

EX9 – OE 1

● Output specification

1	PNP output (-COM.)
---	--------------------

● Power supply type

T	Internal power supply type (for low wattage load)
P	External power supply type (for high wattage load)*

* It is connected to the Power Block while its operation.

Power Block

EX9 – PE1

Part Names

Output Block

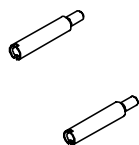
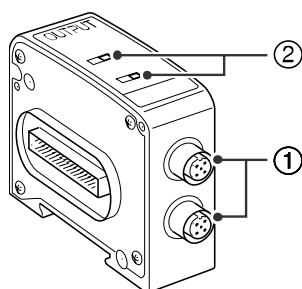

Tie-rod (2 pcs.)
Accessory

No.	Part names	Application
1	Output equipment connector	Connects with output device. ^{Note1)}
2	Operation display LED	Indicates the output status. ^{Note2)}

Note1 : For wiring method, refer to subsection "Wiring" (page 23) of section "EX9 Series Output Block/Power Block" in this Technical Specification.

Note2 : For display, refer to subsection "Display" (page 26) of section "EX9 Series Output Block/Power Block" in this Technical Specification.

Power Block

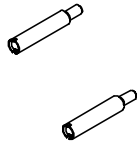
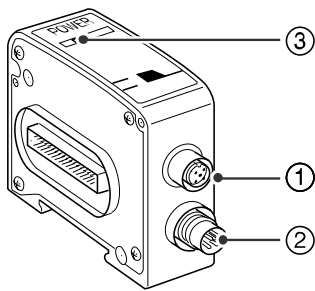

Tie-rod (2 pcs.)
Accessory



Waterproof cap
(for socket)(1 pc.)

No.	Part names	Application
1	Power supply connector	Power can be supplied to SI Unit when connecting SI Unit next to Power Block. ^{Note1)}
2	Power input connector	Supplies power for output devices. ^{Note1)}
3	Operation display LED	Indicates the power supply status. ^{Note2)}

Note1 : For wiring method, refer to subsection "Wiring" (page 23) of section "EX9 Series Output Block/Power Block" in this Technical Specification.

Note2 : For display, refer to subsection "Display" (page 26) of section "EX9 Series Output Block/Power Block" in this Technical Specification.

Dimensions (unit: mm)

Output Block

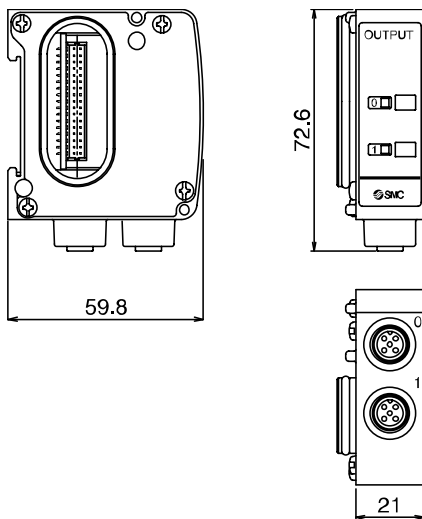

Power Block

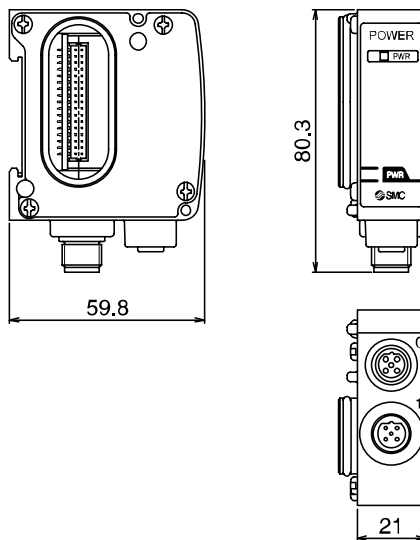

Mounting/Installation

Refer to subsection "Mounting/Installation" (page 8) in this Technical Specification.

Specifications

Output Block

Model No.	EX9-OET1	EX9-OEP1
Power supply type	Internal power supply type	External power supply type (Supplied from the Power Block, EX9-PE1.)
Rated voltage	24VDC	
Output method	PNP output (-COM.)	
Rated load current	Max. 62mA/point	Max. 0.5A/point *

* It is limited to the max. Power Block supply current 3.1A.

NOTE

When connecting an inductive load such as a solenoid valve or relay without build-in surge suppressor, the use of an external surge suppressor is recommended.

Power Block

Power supply voltage range	24VDC+10%/-5%
Output method	PNP output (-COM.)
Supply current	Max. 3.1A (When it is operated with the current between 3.0A and 3.1A, the ambient temperature should be 40 deg. C or lower and the cables should not be bundled.)

Wiring

1. Output wiring

Cable wiring

- 1) Aligning the key groove with the output connector (socket) of Output Block, plug in the cable with connector (plug).
- 2) Tighten the lock nut on cable side by turning it clockwise by hand.
- 3) Confirm that the connector does not move.

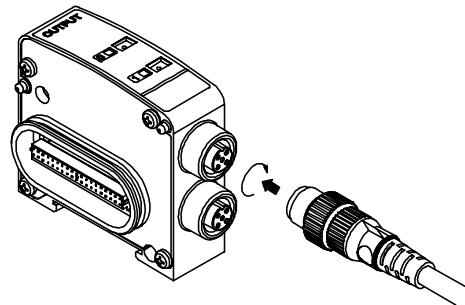

Output connector pin layout

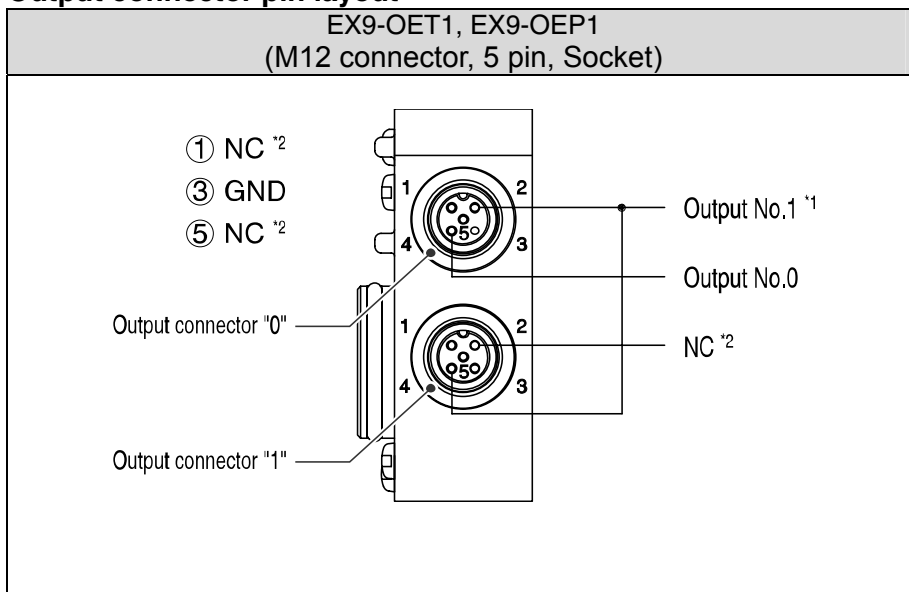

- *1) Output No.1 is connected to the pin No.2 of the output connector "0", and 2 output signals can be directly output from the output connector "0".
*2) NC : Not connected

Pin layout and connection drawing of the Output Cable

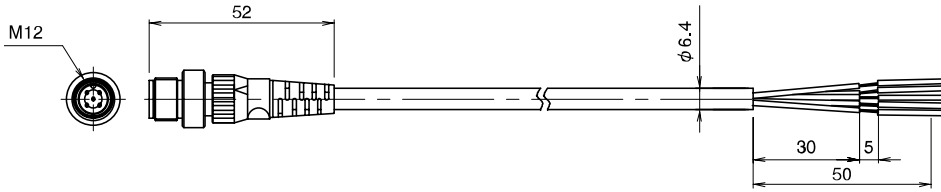

Model No. : EX9-AC□ -7

Pin No	Cable color: Signal name
1	Brown : NC
2	White : Output No.1/NC
3	Blue : GND
4	Black : Output No.0/Output No.1
5	Grey : NC

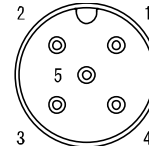

Plug connector pin layout

NOTE

Mount a Waterproof Cap on each unused connector of Output Block. The proper use of Waterproof Cap can achieve IP67 Enclosure. (Tightening torque : 0.1Nm for M12)
 For Waterproof Cap, refer to "Option" (page 27) in this Technical Specification.

Correlation between output number and Output Block

The total number of input and output blocks can not exceed 10.

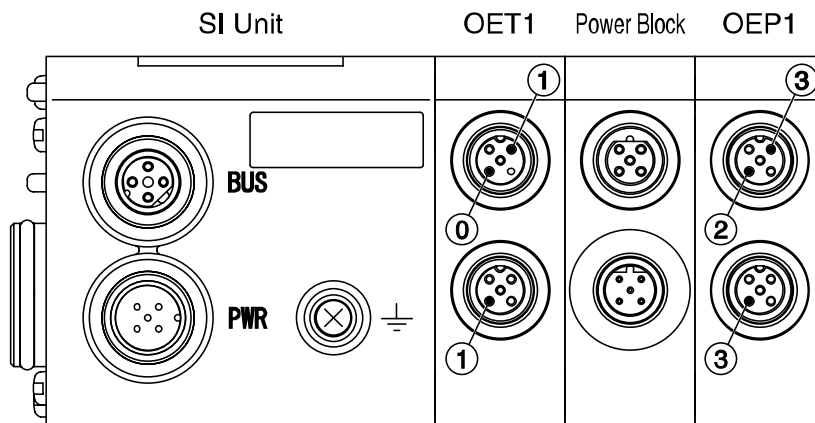

The output number is 1, 2 ... from the SI Unit side.

2. Power supply wiring (Power Block)

When operating EX9-OEP1, combine it with EX9-PE1, and connect the power supply to the power input connector of EX9-PE1.

Cable wiring

- 1) Aligning the key groove with the connector of Power Block, plug in the cable.
- 2) Tighten the lock nut on cable side by turning it clockwise by hand.
- 3) Confirm that the connector does not move.

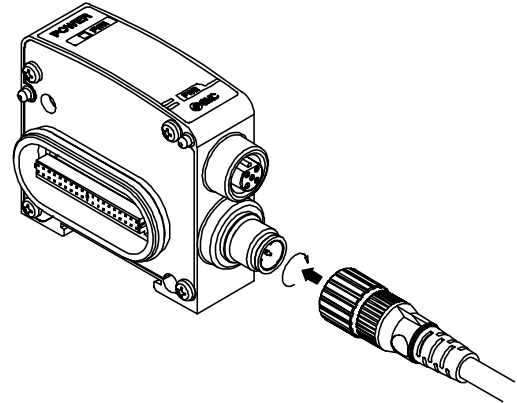

EX9-PE1 pin layout

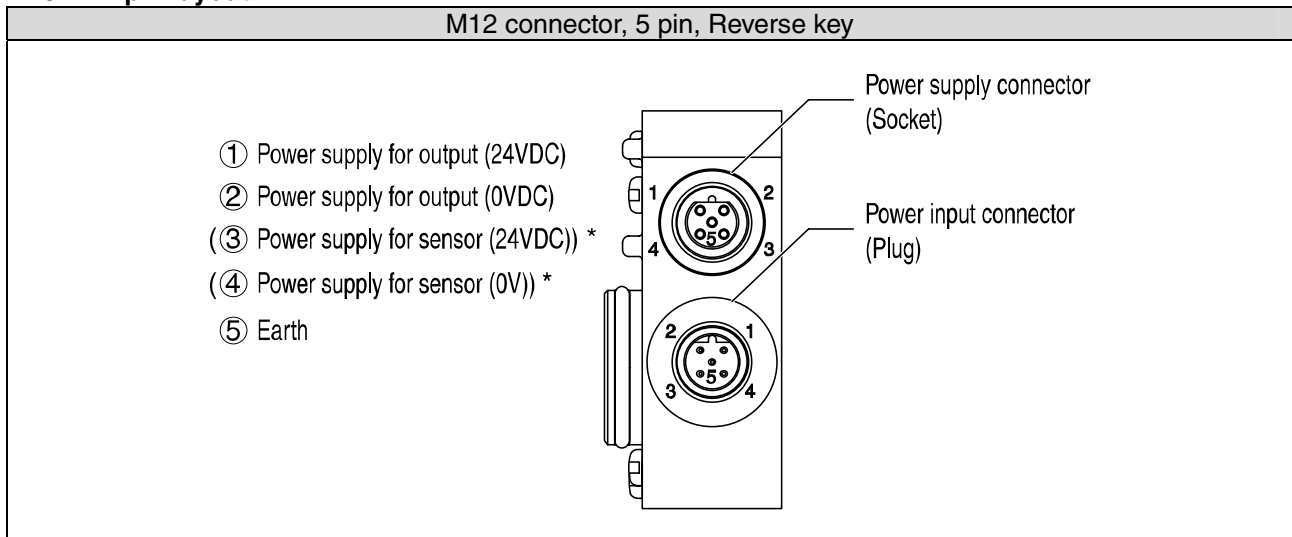

* It is used when power is supplied to SI Unit, using an exclusive cable from the power supply connector. When power is not supplied to the SI Unit from the Power Block, it is not required to connect the power to the pins No.3 and 4 of the power input connector.

Pin layout and connection drawing of the Power Supply Cable

Power Cable (Power Block)

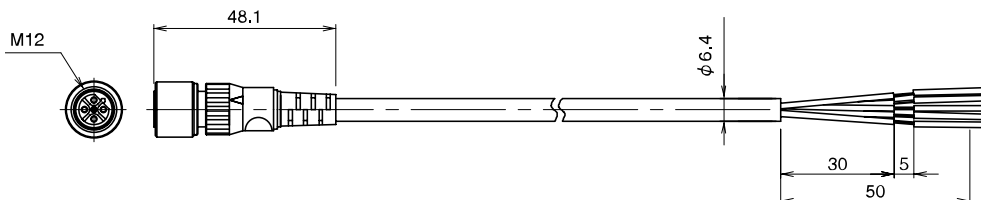

Model No. : EX9-AC□ -1

Pin No	Cable color: Signal name
1	Brown : Power supply for output (24VDC)
2	White : Power supply for output (0V)
3	Blue : (Power supply to sensor (24VDC))
4	Black : (Power supply to sensor (0V))
5	Grey : Earth

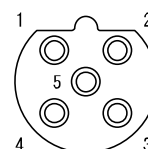

Socket connector pin layout (Reverse key)

Power Cable Jumper (Power Block to EX250-SEN1)

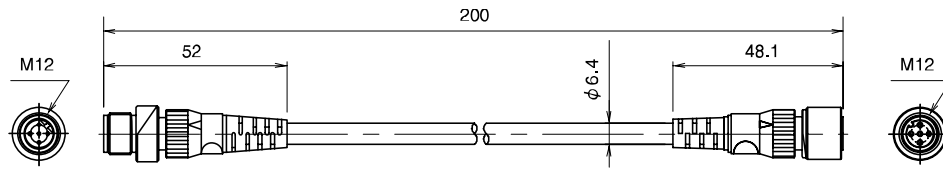

Model No. : EX9-AC002-3

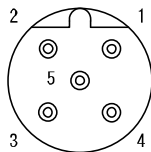

Plug connector pin layout (Reverse key)

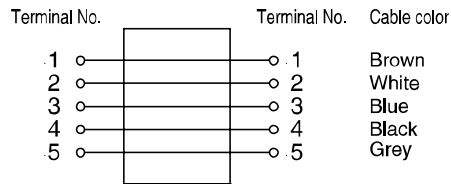

Wiring diagram

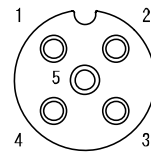

Socket connector pin layout

The Power Supply Cable (for Power Supply Connector of Power Block) is a bypass cable which can be used when the Power Block is positioned next to the SI Unit.

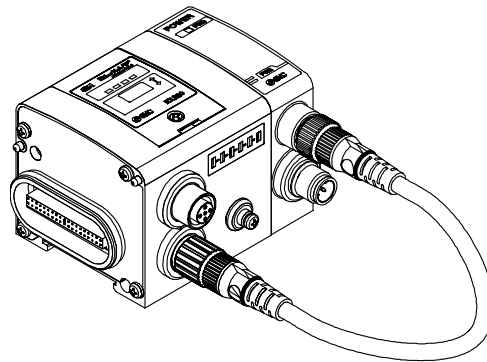

NOTE

Mount a Waterproof Cap on unused Power Supply Connector. The proper use of Waterproof Cap can achieve IP67 Enclosure. (Tightening torque : 0.1N·m for M12)
For Waterproof Cap, refer to "Option" (page 27) in this Technical Specification.

Display Output Block

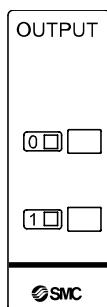

Display	Description	
0,1	Lights up	Output corresponding to the number is ON.
	Off	Output corresponding to the number is OFF.

Power Block

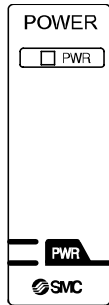

Display	Description	
PWR	Lights up	External power supply is ON.
	Off	External power supply is OFF.

Option

1. Ethernet Communication Cable

For details, refer to subsection "Wiring" (page 12) in section "SI Unit" in this Technical Specification.

How to order

EX9-AC 020 EN- PSRJ

Cable length		Connector specification	
020	2 [m]	PSRJ	M12 plug (straight) ↔ RJ45 connector

2. Power Supply Cable

For details, refer to subsection "Wiring" (page 13) of section "SI Unit" in this Technical Specification.

How to order

EX500-AP 050 - S

Cable length		Connector specification	
010	1 [m]	S	Straight
050	5 [m]		

3. Spare Fuse (for Input Block)

How to order

EX9-FU 05

Rating	
05	0.5[A]

4. Output Cable

For details, refer to subsection "Wiring" (page 23) of section "EX9 series Output Block/Power Block" in this Technical Specification.

How to order

EX9-AC 010 -7

Cable length	
010	1 [m]
030	3 [m]

5. Power Supply Cable (for power input connector of Power Block)

For details, refer to subsection "Wiring" (page 25) of section "EX9 series Output Block/Power Block" in this Technical Specification.

How to order

EX9-AC 010 -1

● Cable length	
010	1 [m]
030	3 [m]
050	5 [m]

6. Power Supply Cable (for power supply connector of Power Block)

For details, refer to subsection "Wiring" (page 25) of section "EX9 series Output Block/Power Block" in this Technical Specification.

How to order

EX9-AC 002 -3

● Cable length	
002	0.2 [m]

7. End Plate (Input Block side)

How to order

EX250-EA 1

● Mounting method	
1	Standard product
2	For DIN rail mounting

Accessory

Hexagon thin socket head bolt (2 pcs.)

EX250-EA1

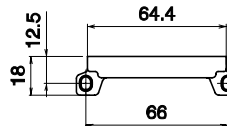

EX250-EA2

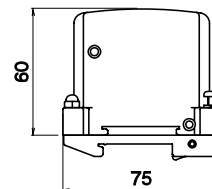
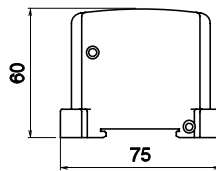
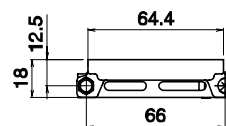

8. End Plate R (Output Block side)

How to order

EX9-EA 03

● Mounting method	
03	Standard product
04	For DIN rail mounting

EX9-EA03

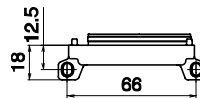

EX9-EA04

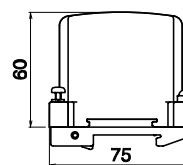
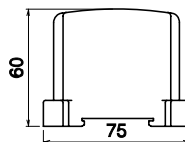
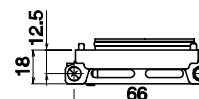

9. Waterproof Cap

Mounted on the unused ports of the Input Block, Output Block and Power Block.

The proper use of this Waterproof Cap can achieve IP67 Enclosure. (The Waterproof Caps are delivered together with the Power Block as accessories.)

How to order

EX500-AW□

Connector specification

ES	M8 connector (for socket) / 10 pcs.
TS	M12 connector (for socket) / 10 pcs.



NOTE

Tighten the Waterproof Cap by the specified tightening torque. (0.05N·m for M8, 0.1N·m for M12)

Maintenance procedure

How to replace SI unit

- Remove screws mounted on the endplate, and separate it from the valve unit.
- Replace the SI unit (Tie rods should not be removed).

Mount the removed endplate, and tighten it with the same screws with a specified tightening torque. (0.6N·m)

⚠ Precautions on maintenance

- (1) Be sure to check that all the power supply is turned off.
- (2) Foreign substances shall not be intruded in the unit.
- (3) Foreign substances or scratches shall not be present on the gasket.
- (4) Screws shall be tightened with a specified tightening torque.

If they are not set properly, it will lead to board failure, or liquid and or dust might be intruded in the unit.

How to assemble and disassemble SI unit

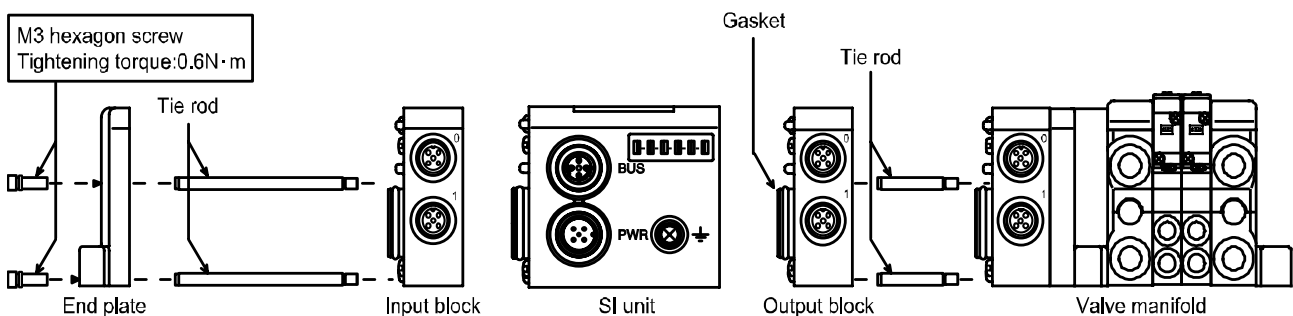

Troubleshooting

Troubleshooting flow chart

If a SI unit malfunctions, select the specific trouble with the flow chart stated below.

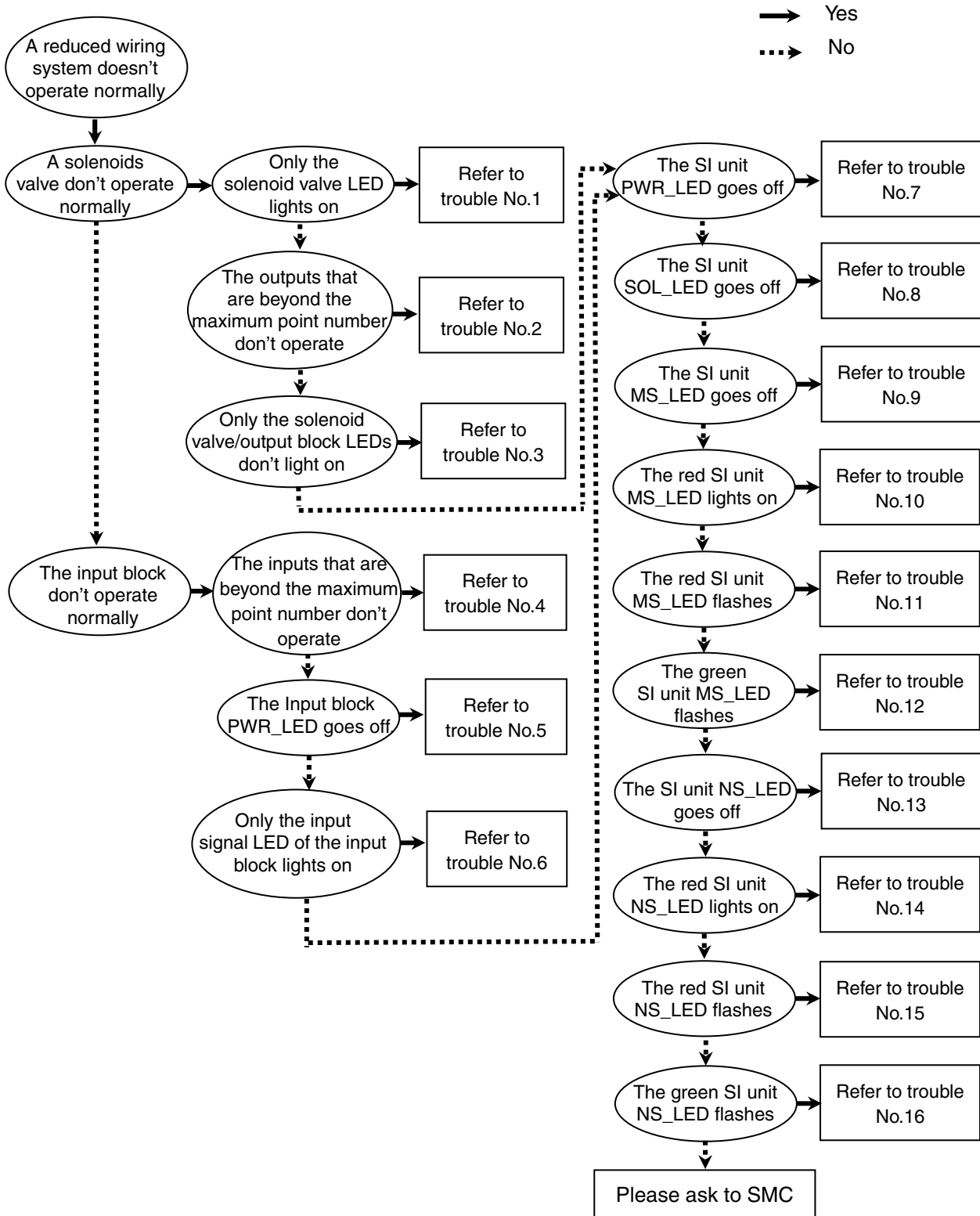

Trouble

Trouble No.1

Trouble	Possible cause	Investigation method of cause	Remedy
Only the solenoid valve LED lights on.	Solenoid valve failure.	Check the troubleshooting for the solenoid valve.	Same as left.

Trouble No.2

Trouble	Possible cause	Investigation method of cause	Remedy
The outputs that are beyond the maximum point number do not operate.	Inadequate total number of outputs from the solenoid valves and output block connected with the SI unit.	Check if the total number of outputs is 32 or less (24 for the solenoid valve VQC series).	Eliminate extra unused outputs from the manifold to ensure the number of outputs is 32 or less.

Trouble No.3

Trouble	Possible cause	Investigation method of cause	Remedy
Only the solenoid valve/output block LEDs do not light on.	Incorrect wiring for the power supply for solenoid valve and the power supply for output.	Check that the power supply cable for the solenoid valve and output is not broken, and that the connection between the power supply cable and connector has not loosened.	Review the connection condition of the power supply cable. (If the cable is broken, replace it with a new one.)
		Check that there is no incorrect wiring of the power supply cable.	Review the wiring condition of the power supply cable.
	Failure of the power supply for the solenoid valve and output.	Check the supply voltage to the power supply for the solenoid valve and output.	Supply 24VDC +10%/-5% to the power supply for the solenoid valve and output.
	Incorrect connection between the SI unit and the solenoid valve and/or output block.	Check that the bolt joining the SI unit with the solenoid valve and output block has not loosened.	Tighten the bolts by hand so that there is no gap between the SI unit and the solenoid valve and/or output block. Tighten to the specified torque. (Tightening torque: 0.6Nm)
		Check if the output block (for high wattage and load and low wattage and load) and power block are mounted in the right position.	Review the position of the output block and power block.
Intrusion of liquids such as water.	Check that unused connectors of the output block and power block are plugged with waterproof caps.	If liquid such as water has got into the output block and/or power block, replace the output block and power block with new ones.	

Trouble No.3

Trouble	Possible cause	Investigation method of cause	Remedy
Only the solenoid valve/output block LEDs do not light on.	Incorrect connection of the load with the output block.	Check that the output load cable is not broken, and that the connection between the output load and connector has not loosened.	Review the connecting condition of the output load. (If the cable is broken, replace it with a new one.)
		Check if the specifications of the SI unit match those of the output load (+ common, - common).	Use - common with the output load for the PNP output.
	Inconsistent polarity between the solenoid valve (VQC1000/2000) and output block.	Check if the specifications of the SI unit match those of the solenoid valve and output block (+ common, - common).	Use - common with the solenoid valve and output block suitable for the PNP output of the SI unit.
	Failure of the solenoid valve and/or output block.	Check the troubleshooting for the solenoid valve.	Same as left.
Replace the SI unit with a new one and operate to check the normal operation recovers.		Replace the SI unit with a new one.	

Trouble No.4

Trouble	Possible cause	Investigation method of cause	Remedy
The inputs that are beyond the maximum point number do not operate.	Inadequate total number of inputs from the input block connected with the SI unit.	Check if the total number of inputs is 32 or less.	Eliminate extra unused inputs from the manifold to ensure the number of inputs is 32 or less.

Trouble No.5

Trouble	Possible cause	Investigation method of cause	Remedy
The Input block PWR_LED goes off.	Failure of the power supply for the input and control of the SI unit.	Check the supply voltage to the power supply for the input and control of the SI unit.	Supply 24VDC \pm 10% to the power supply for the input and control.
	Incorrect connection between the SI unit and input block.	Check that the bolt joining the SI unit and input block has not loosened.	Tighten the bolts by hand so that there is no gap between the SI unit and input block. Tighten to the specified torque. (Tightening torque: 0.6Nm)
	The input block fuse has melted.	Check if the fuse of the input block has melted.	Remove the cause of the short-circuit and replace the fuse with a new one.
	Intrusion of liquids such as water.	Check that unused connectors of the input block are plugged with waterproof caps.	If liquid such as water has got into the input, replace the input block with a new one.
	Input block failure.	Replace the input block with a new one and operate to check the normal operation recovers.	Replace the input block with a new one.

Trouble No.6

Trouble	Possible cause	Investigation method of cause	Remedy
Only the input signal LED of the input block lights on.	Inconsistent polarity in sensors.	Check the specifications of the input block (NPN, PNP) match those of the sensor.	Make a suitable combination of input block and sensor.
	Incorrect connection of the sensor.	Check that the sensor cable is not broken and that the connection between the sensor cable and connector has not loosened.	Review the connection condition of the sensor cable. (If the cable is broken, replace it with a new one.)
	Sensor failure.	Check the troubleshooting of the sensor.	Same as left.

Trouble No.7

Trouble	Possible cause	Investigation method of cause	Remedy
The SI unit PWR_LED goes off.	Incorrect wiring of the power supply for the input and control.	Check that the power supply cable for the input and control is not broken, and that the connection between the power supply cable and connector has not loosened.	Review the connection condition of the power supply cable. (If the cable is broken, replace it with a new one.)
		Check that there is no incorrect wiring of the power supply cable.	Review the wiring condition of the power supply cable.
	Failure of the power supply for the input and control.	Check the supply voltage to the power supply for the input and control.	Supply 24VDC $\pm 10\%$ to the power supply for the input and control.

Trouble No.8

Trouble	Possible cause	Investigation method of cause	Remedy
The SI unit SOL_LED goes off.	Incorrect wiring for the power supply for solenoid valve and the power supply for output.	Check that the power supply cable for the solenoid valve and output is not broken, and that the connection between the power supply cable and connector has not loosened.	Review the connection condition of the power supply cable. (If the cable is broken, replace it with a new one.)
		Check that there is no incorrect wiring of the power supply cable.	Review the wiring condition of the power supply cable.
	Failure of the power supply for the solenoid valve and output.	Check the supply voltage to the power supply for the solenoid valve and output.	Supply 24VDC $+10\%/-5\%$ to the power supply for the solenoid valve and output.

Trouble No.9

Trouble	Possible cause	Investigation method of cause	Remedy
The SI unit MS_LED goes off.	Abnormal status of the SI unit.	Check if the Earth terminal is grounded.	Provide grounding to improve the noise resistance of the reduced wiring system.
		Provide grounding to improve the noise resistance of the reduced wiring system.	Carry out measures like separating the power supply cable from the power line and/or high voltage line and restart the power supply of the SI unit.

Trouble No.10

Trouble	Possible cause	Investigation method of cause	Remedy
The red SI unit MS_LED lights on.	Abnormal status of the SI unit.	Check if the Earth terminal is grounded.	Provide grounding to improve the noise resistance of the reduced wiring system.
		Check if the power supply line is in the same route as the power line and/or high voltage line.	Separate the power supply cable from the power line and/or high voltage line.
	SI unit failure.	Replace the SI unit with a new one and operate to check the normal operation recovers.	Replace the SI unit with a new one.

Trouble No.11

Trouble	Possible cause	Investigation method of cause	Remedy
The red SI unit MS_LED flashes.	Abnormal status of the SI unit.	Check if the Earth terminal is grounded.	Provide grounding to improve the noise resistance of the reduced wiring system.
		Check if the power supply line is in the same route as the power line and/or high voltage line.	Separate the power supply cable from the power line and/or high voltage line.

Trouble No.12

Trouble	Possible cause	Investigation method of cause	Remedy
The green SI unit MS_LED flashes.	Setting error.	Check the setting of the SI unit.	Review the setting of the SI unit.

Trouble No.13

Trouble	Possible cause	Investigation method of cause	Remedy
The SI unit NS_LED goes off.	IP address not set.	Check the setting of IP addresses.	Review the setting of IP addresses.

Trouble No.14

Trouble	Possible cause	Investigation method of cause	Remedy
The red SI unit NS_LED lights on.	Duplicated IP address.	Check that there is no duplicated IP address.	Review the setting of IP addresses.

Trouble No.15

Trouble	Possible cause	Investigation method of cause	Remedy
The red SI unit NS_LED flashes.	Broken communication line.	Check that there is no broken communication line or loosened connector.	Review the connection condition of the communication line. (If the cable is broken, replace it with a new one.)
		Check if the PLC is operating normally.	Review the setting of PLC.

Trouble No.16

Trouble	Possible cause	Investigation method of cause	Remedy
The green SI unit NS_LED flashes.	Waiting for connection to be established.	Check the address and communication setting.	Review the setting of the switch and address.
		Check that there is no broken communication line or loosened connector.	Review the connection condition of the communication line. (If the cable is broken, replace it with a new one.)
		Check if the PLC is operating normally.	Review the setting of PLC.

Revision history

SMC Corporation

URL <http://www.smcworld.com>

Note: Specifications are subject to change without prior notice and any obligation on the part of the manufacturer.
The descriptions of products shown in this document may be used by the other companies as their trademarks.
© 2006 SMC Corporation All Rights Reserved



No.EX##-OMK0004