



Signal[®] Mirror Installation Instructions

Chevy Blazer 1992-1994, Chevy Suburban 1992-1999, Chevy Tahoe 1995-1999, Chevy Tahoe Limited 2000, GMC Suburban 1992-1999, GMC Yukon 1992-1999, GMC Yukon Denali 2000, Chevy CK Pickup (Classic Body Style) 1988-2000, Chevy Silverado (Classic Body Style) 1999-2000, GMC Sierra Pickup 1988-1998, GMC Sierra Pickup (Classic Body Style) 1999-2000, Cadillac Escalade 1999-2000
GMC Mid Size Vans: *GMC Safari 1990-2001, *Chevy Astro 1990-2001 (see required parts below)



THE safety accessory of the 21st Century. TM

P/N 210-0004-0

Rev A2 1-4-06, GG

© 2002 Muth Mirror Systems, LLC.

INCLUDED ITEMS:

1 left and 1 right *Signal*® mirror
1 left and 1 right wire harness
2 wire taps
2 ring connectors
1 instruction manual

REQUIRED TOOLS:

Ratchet with extension or ratcheting screwdriver
10mm socket
8mm socket
11mm socket
10mm box wrench
Small slotted screwdriver
Medium Philips screwdriver
Needle nose pliers
Small pry bar
Gopher wire
Electrical tape
Wire crimper and stripper
Needle nose pliers
Masking tape
Multimeter or wire tester
Sturdy gloves
Safety glasses or goggles

REQUIRED PARTS:

Two additional wire-taps are required for 2000/2001 Astro & Safari (some 1999). They are available at most auto part stores.

Please read instructions prior to installation.

PROBLEMS OR QUESTIONS?

Technical Assistance is available by calling Muth Mirror Systems Technicians at:

1-800-844-6616

Monday through Friday
Between 8:00 a.m. and 5:00 p.m. CST

Or through the Muth web site:

www.muthco.com

Or via E-mail: techsupport@muthco.com

Mirror Housing Removal for CK Pickup, Suburban, Tahoe, Yukon, Escalade and Blazer (full size)

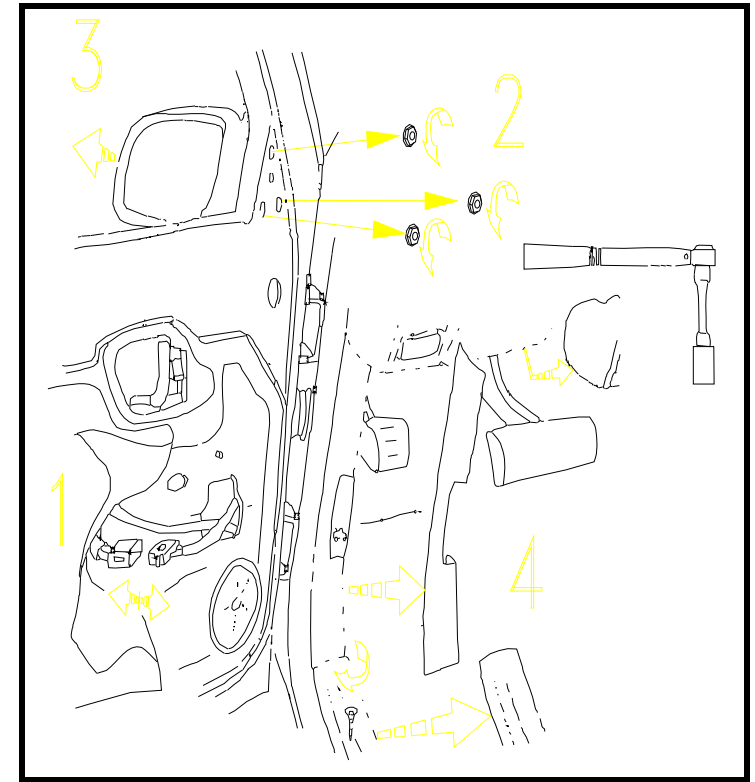
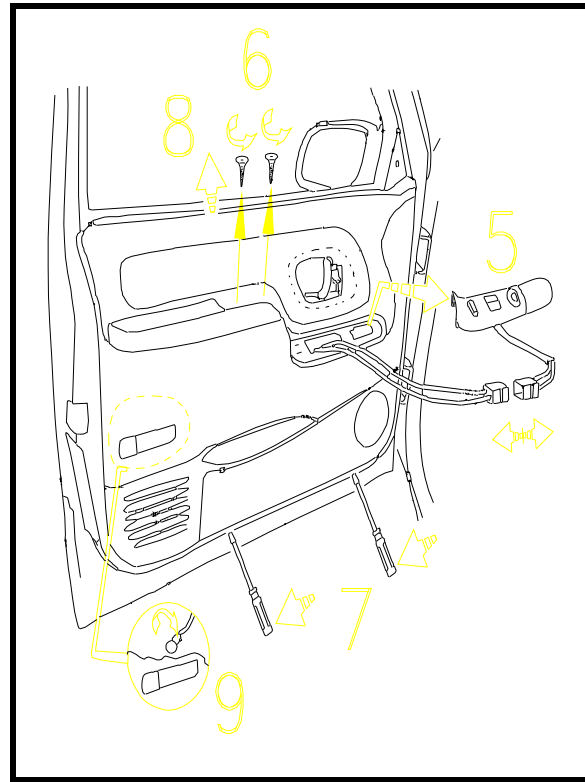
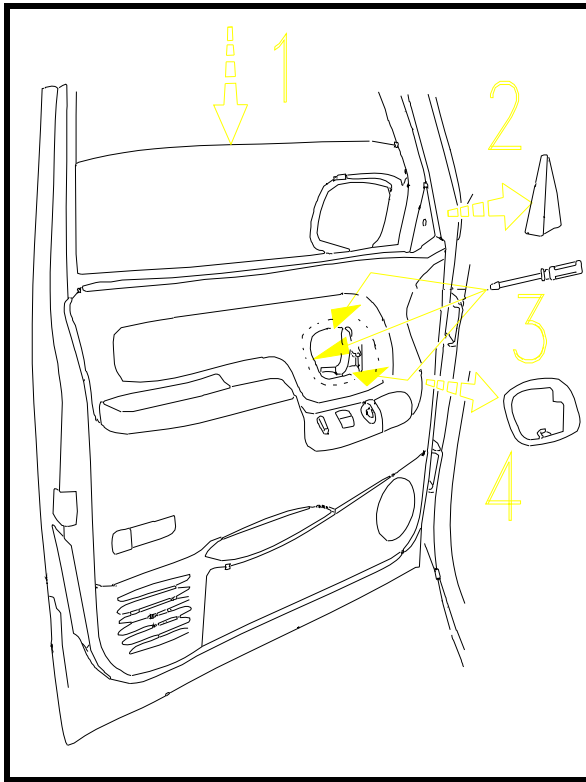

PROCEDURE A1:

- 1) Lower window.
- 2) Unsnap corner molding.
- 3) Pry gently with small screwdriver in three (3) locations to unsnap door handle molding.
- 4) Remove door handle molding.
- 5) Unsnap window and mirror control panel and disconnect harnesses.
- 6) Remove screws from arm rest.
- 7) Pry underneath door panel with screw driver or panel removal tool to loosen panel snaps.
- 8) Lift door panel upward.
- 9) Remove marker bulb from bracket in door panel and set panel aside.

PROCEDURE B1:

- 1) Pull back plastic sheeting, and unplug mirror controller connector.
- 2) Remove triangular foam pad. Secure mirror with one hand. Proceed cautiously to avoid dropping articles into the door panel. Remove the 3 mirror mounting nuts.
- 3) Remove mirror from door.
- 4) Remove floor molding, side kick panels, and lower dash panel.

Mirror Housing Removal for Astro Van and Safari Van

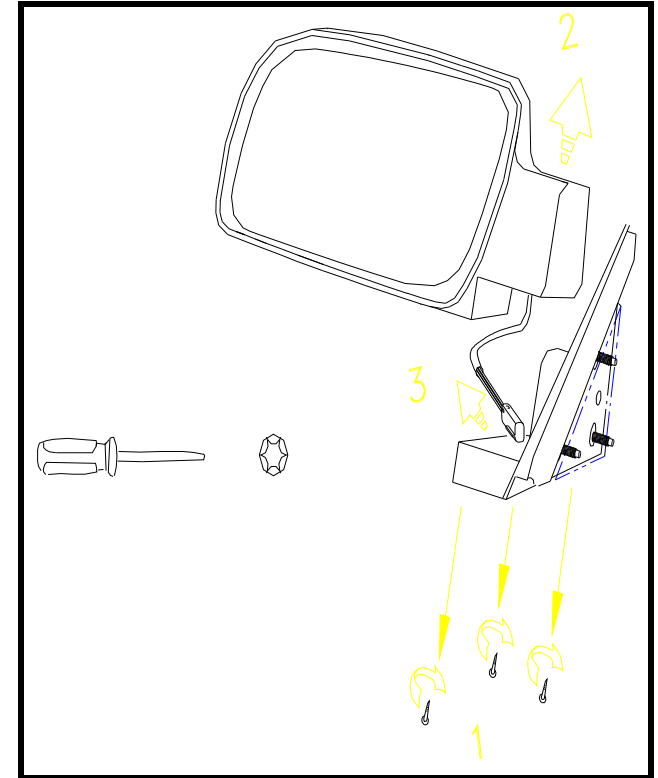
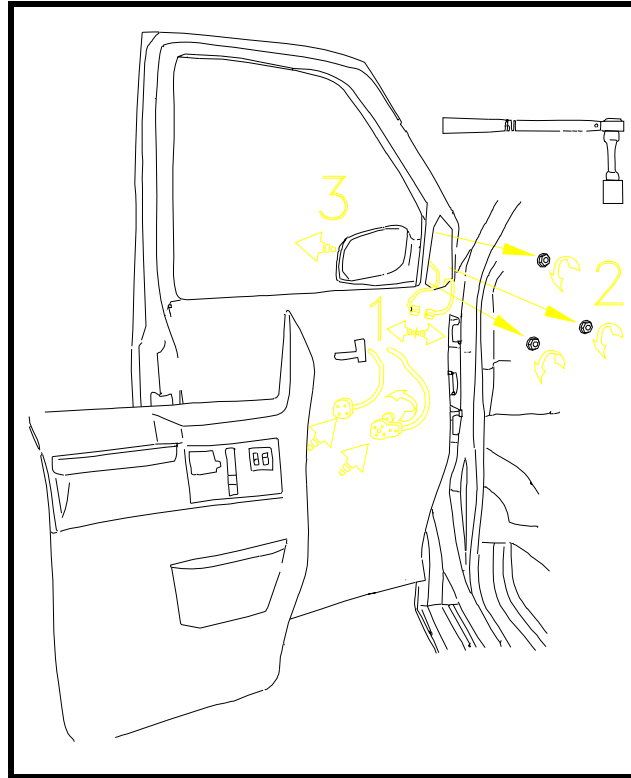
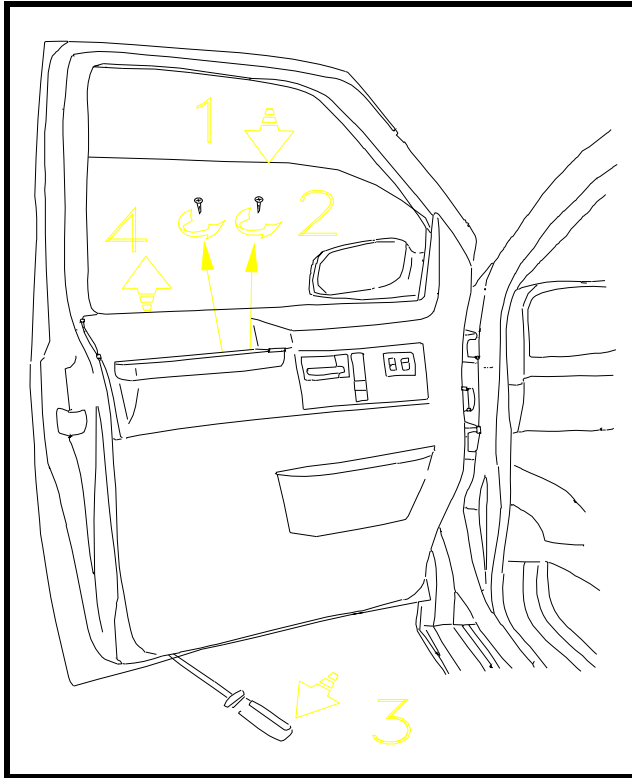

PROCEDURE A:

- 1) Lower window.
- 2) Remove the two screws located in the arm rest.
- 3) Pry around the perimeter of the door panel with a door panel removal tool or a flat blade screwdriver to unsnap the door panel from the door.
- 4) Dislodge the door panel by carefully pulling up and away from the door.

PROCEDURE B:

- 1) Unplug the connectors for the door lock, power window, and mirror controller. Remove the door panel from the door.
- 2) Secure mirror with one hand. Proceed cautiously to avoid dropping articles into the door panel. Remove the 3 mirror mounting nuts.
- 3) Remove mirror from door.

PROCEDURE C:

- 1) Set one of your standard mirrors on a clean level surface. Remove the 3 screws located at the base of the mirror mounting panel.
- 2) Remove the mirror housing from its mounting panel.
- 3) Slide the mirror harnesses through the wire routing passage.
- 4) Repeat these steps for the other standard mirror and for the Signal® mirrors.

Mirror Housing Attachment for Astro Van and Safari Van

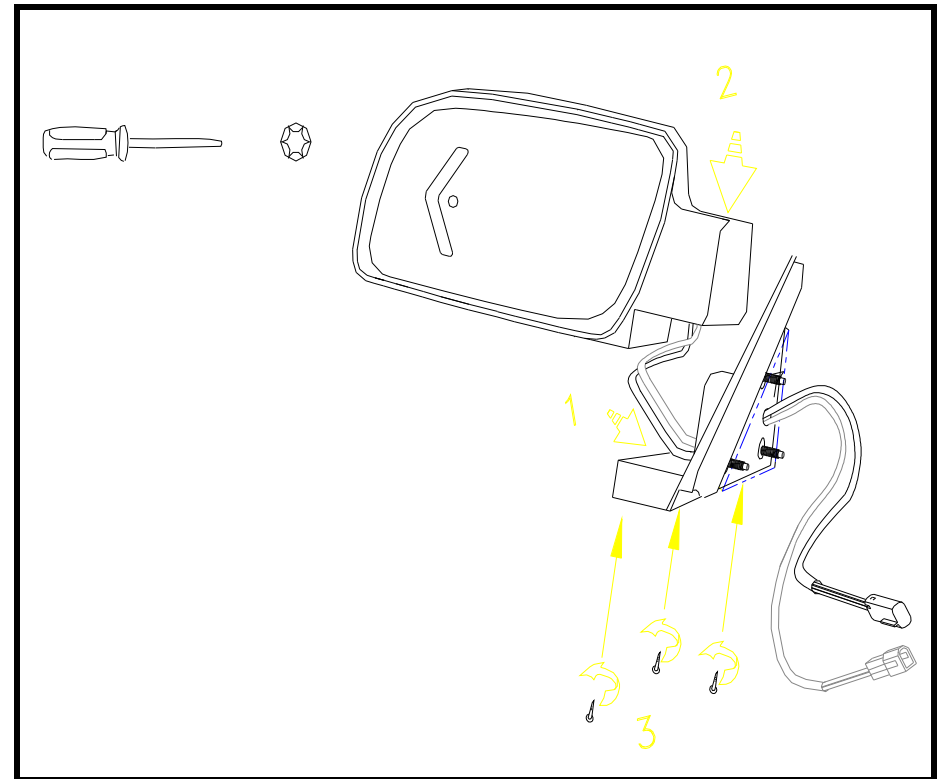
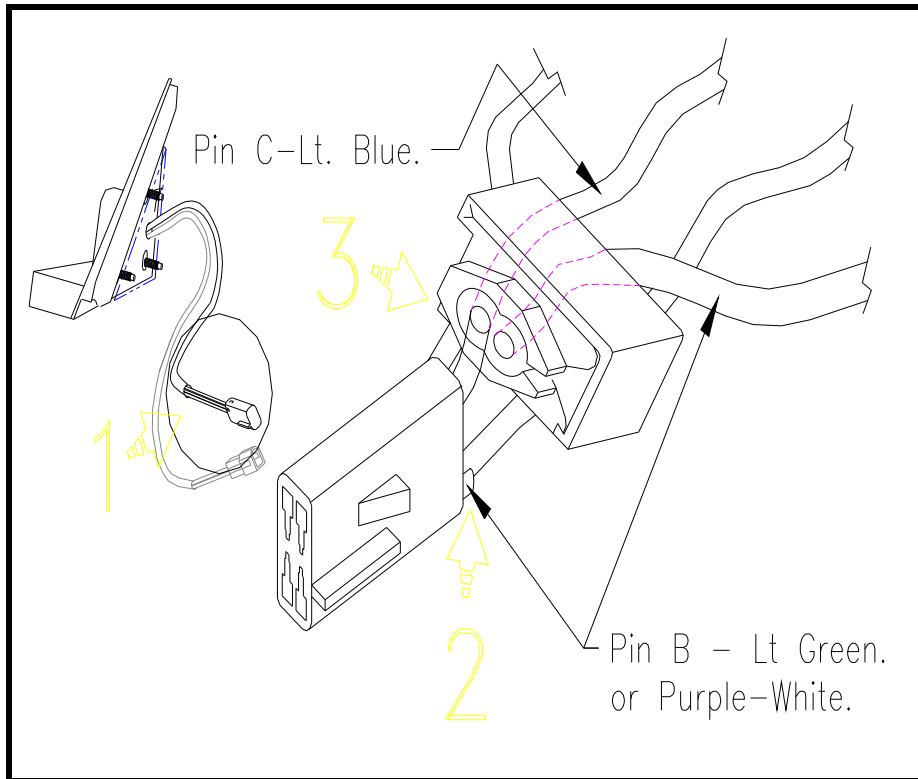

PROCEDURE D:

For (some 1999), 2000, and 2001 Astro and Safari: If harness from vehicle consists of **4 wires**, skip to next procedure. If harness from vehicle consists of **3 wires**, modify the wire harness on both mirrors as follows:

- 1) Strip back about 1.5 inches of black sheath next to the black 4-pin connector.
- 2) On each mirror, cut the wire going to pin B (Lt. Green on Left, Purple-White on Right) next to the connector.
- 3) Using a wire tap, connect the cut wire to the wire going to pin C (Lt. Blue on both sides).

Mirrors are now ready to install on vehicle.

PROCEDURE E:

- 1) Place a *Signal*® mirror on the clean flat surface and route the harnesses through the routing passage in the appropriate standard mirror mounting frame.
- 2) Slide the *Signal*® mirror housing into place on the mounting frame.
- 3) Attach the mirror housing to the frame with the original 3 screws.
- 4) Repeat these steps for the other *Signal*® mirror.

Wiring

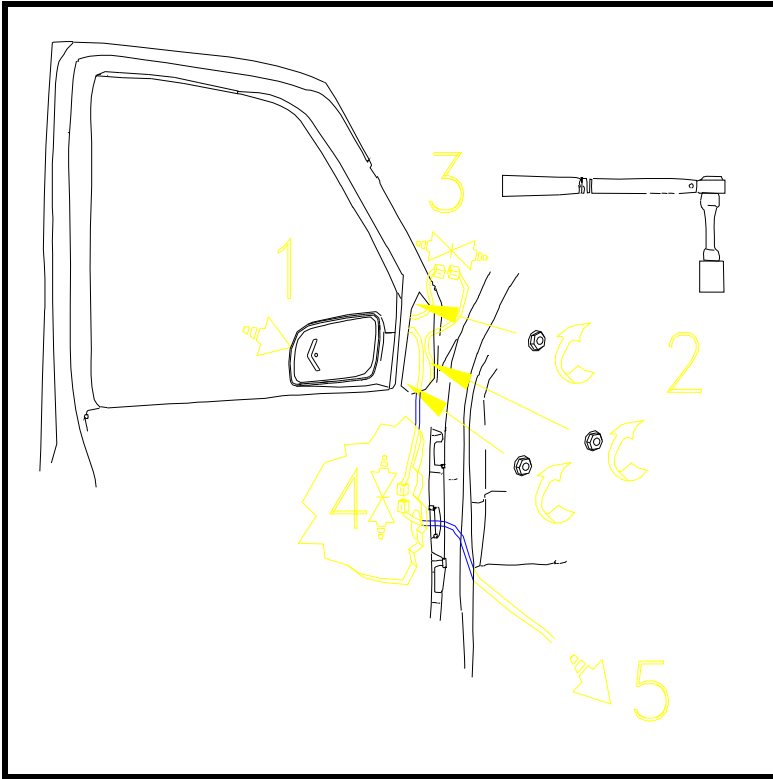

PROCEDURE F:

- 1) Feed wires into door and set *Signal*® mirror in place.
- 2) Attach mirror with original 3 nuts. Do not over tighten.
- 3) Reconnect the mirror controller harness.
- 4) Plug the appropriate harness into the *Signal*® mirror leads (the short harness is for the driver side and the long harness is for the passenger side).
- 5) Pass *Signal*® mirror harness through the rubber boot between the door and the vehicle and into the area below the dash.

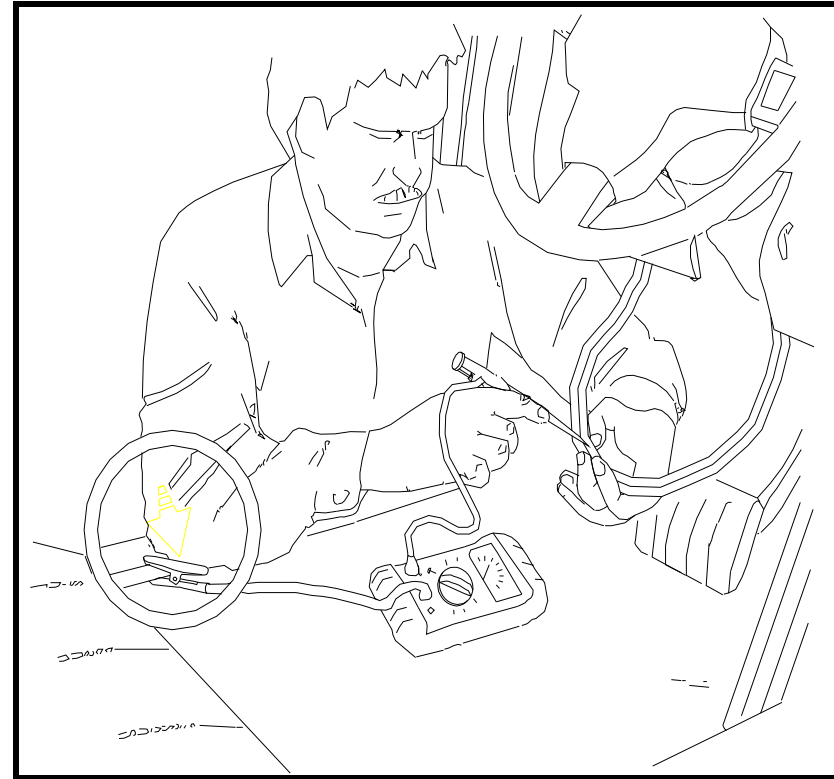

PROCEDURE G:

1. Locate the LIGHT BLUE wire from within the wire bundle. Turn the ignition key so that electrical power is on and activate the driver side turn indicator. Probe the wire with the wire tester to verify that flashing turn indicator power is present. Label that wire as 'driver side turn'.
2. Locate the DARK BLUE wire from within the wire bundle. Activate the passenger side turn indicator and probe the wire with the wire tester to verify that flashing turn indicator power is present. Label that wire as 'passenger side turn'.

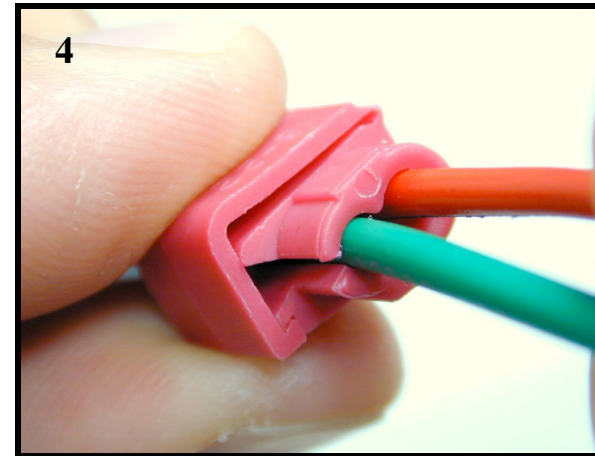
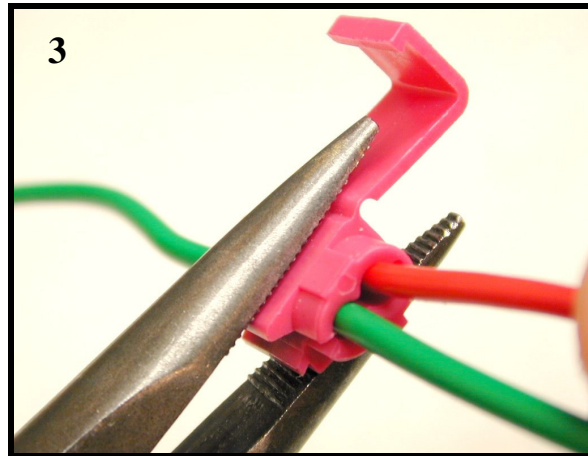
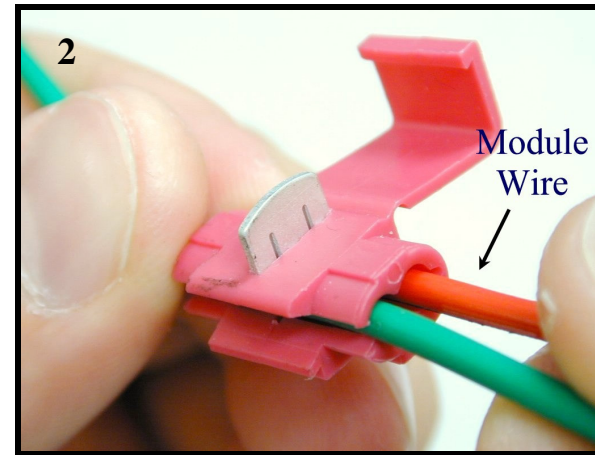
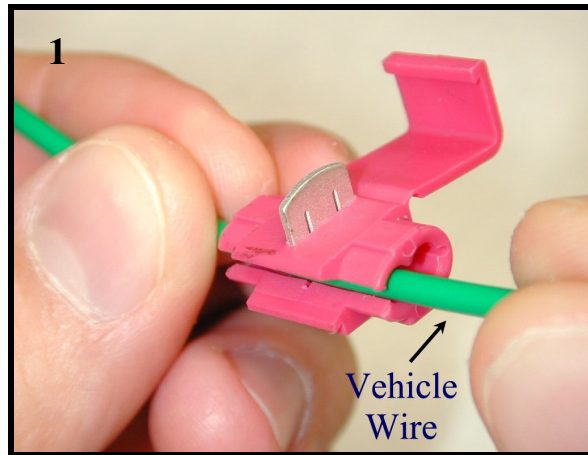

USE THE INCLUDED WIRE TAPS AND FOLLOW THE FOUR STEPS ABOVE TO SPLICE INTO THE TURN INDICATOR WIRES

1. Make sure the harnesses are routed securely under the dash and enough slack is left for splicing.
2. Splice the RED wire from the driver side harness into the light blue wire previously labeled 'driver side turn'.
3. Splice the RED wire from the passenger side harness into the dark blue wire previously labeled 'passenger side turn'.
4. Strip and twist together the ends of the black wires from each harness. Crimp them together in the supplied ring connector and ground to a suitable nearby location on the metal framework of the vehicle.
5. Activate each turn indicator to verify that the *Signal*[®] mirrors are working.
6. Replace any door accessories, door panels, plastic moldings, and trim pieces.

