

PHILIPS

Sensors

EasyAir

SNS200



Design-in Guide

Single, compact, **cost-effective** luminaire control

Philips EasyAir SNS200

October 2019

Contents

Introduction to this guide	3	Phone-based app and configuration	26
More information or support	3		
Warnings and instructions	4	Mechanical design-in	27
Introduction of EasyAir SNS200	5	Wire strip length	27
Product characteristics	6	Wire insertion	27
EasyAir SNS200 overview	6	Wire separation from the connector	27
NFC antenna	6	Wiring Information	27
RF antenna	6	Wire distance for remote mounting Recommendations	28
Infrared (IR) receiver	6	to design-in a luminaire	28
Motion detector	7	around EasyAir SNS200 with good RF signal	28
Sensor view shield	8	in a bracket (SMB-50)	29
Light sensor	9	Installing EasyAir SNS200 with ceiling mount bracket	30
LED indicator	9	(SNS200CMP)	30
Daylight calibration and System startup behavior	10	Mounting distance guidelines for EasyAir SNS200CMP	31
Daylight Calibration	10	EasyAir SNS200 with multiple Philips Xitanium SR	32
System startup behavior	10	LED drivers (1:N application)	32
Lighting control	11	FAQ	33
Terminology used in this chapter	11	Contact details	35
Occupancy-based lighting control	13	Philips EasyAir SNS200	35
Task tuning	13	Disclaimer	36
Daylight harvesting	14		
Daylight dependent override	15		
Daylight dependent switching	16		
Occupancy sensing	18		
Switch-on/off sequence	18		
Manual dimming override	19		
Group occupancy sharing			
(SNS200 and future generations)	21		
Scene setting (SNS200 and future generations)	24		
A conference room for presentations	24		

Introduction to this guide



Philips EasyAir SNS200

Thank you for choosing the Philips EasyAir SNS200. In this guide luminaire manufacturers will find the information required to design this product into a luminaire and configure it to suit specific applications. This design-in guide covers sensor functionality, mechanical mounting, wiring details, configuration and commissioning (grouping) method, application notes and frequently asked questions. For sensor specifications, please see the datasheet available at www.lighting.philips.co.uk/oem-emea/products/connected-lighting.

More information or support

For further information or support, please consult your local Philips sales representative or visit www.lighting.philips.co.uk/oem-emea/support/technical-downloads.

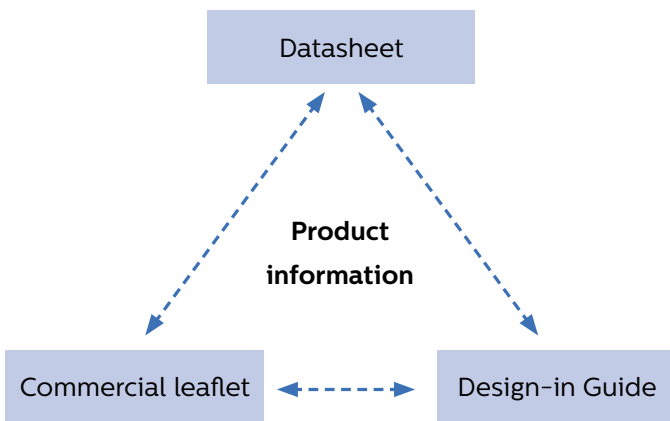

Warnings and instructions

- EasyAir SNS200 must be used only with Philips Xitanium SR LED driver.
- Do not apply mains power directly to the sensor.
- Do not cover the sensor during operation or mount the sensor recessed.
- External infrared light source in the space might have influence on occupancy detection.
- Incorrect location of sensor (e.g., outside the view angle of the occupancy sensor) will result in occupancy detection not functioning correctly.
- When recalibration is needed for adapting to environment changes, make sure the Philips Xitanium SR driver is power cycled. See System startup behaviors/ Auto-calibration section for details.
- Faulty settings of the sensor might result in undefined startup behavior; make sure field task level is set higher than the background light level.
- Make sure the sensor, especially the occupancy detection lens, is protected from damage during shipment and handling.
- The application area of EasyAir SNS200 is designed for a typical indoor environment (open/private offices, conference rooms, classrooms, corridors, etc.) in normally heated and ventilated areas. EasyAir SNS200 has no protection against aggressive chemicals or water.
- Make sure the the EasyAir SNS200 RF antenna is not covered by metal for proper RF communication.

Introduction of EasyAir SNS200



The Philips EasyAir SNS200 is the ideal solution for per-luminaire control of new light luminaires. It combines occupancy sensing, daylight harvesting and task tuning in a single, compact package for easy OEM luminaire assembly. EasyAir SNS200 operates with the established Philips Xitanium SR LED driver standard to make a simple two-wire connection between sensor and driver, thus eliminating the need for multiple components and auxiliary devices. The result is a cost-effective and easy-to-design-in solution ideal for energy-savings. An intuitive app makes configuration and commissioning during and after installation fast and easy using Philips Field Apps.

EasyAir SNS200 with advanced grouping functionality enables addition of qualified wireless switches. Up to 40 sensors can be grouped to a switch using Philips Field Apps. In addition to easily adding user control to a space, the grouping feature facilitates auto-off/manual-on use cases. Furthermore, advanced grouping allows scene setting (e.g., presentation mode for a conference room) as well as occupancy sharing (i.e., luminaires within a group can be programmed to remain at prescribed light levels so long as occupancy is detected anywhere in the group).

EasyAir SNS200 is available in three colours: white, grey and black. Please refer to the SNS200 datasheet on the technical downloads page.

www.lighting.philips.co.uk/oem-emea/support/technical-downloads

Product characteristics

EasyAir SNS200 overview

EasyAir SNS200 contains multiple functions in one housing and uses two wires to connect with an SR driver. (See wiring diagram in the Mechanical design-in section.)

Functions include:

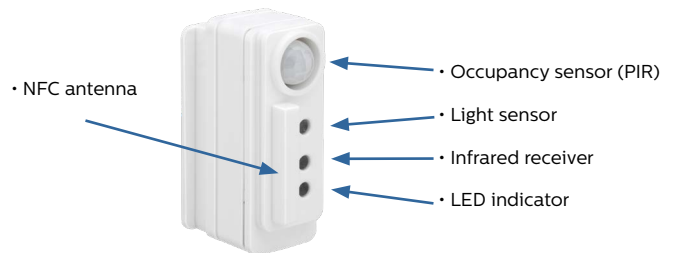

EasyAir SNS200 is designed for a typical indoor environment (open/private offices, conference rooms, classrooms, corridors, etc.) in normally heated and ventilated areas. EasyAir SNS200 has no protection against aggressive chemicals or water. The sensor is normally mounted to a luminaire and is optimized for a sensor mounting height of 2.5 m to 3 m.

NFC antenna

The EasyAir SNS200 can be configured through NFC (near field communication) using a smart phone with the EasyAir SNS200 NFC app. NFC is the set of protocols that enables electronic devices to establish radio communication with each other by touching the devices together or bringing them into proximity to a distance of typically 0.4"/1 cm or less. Parameters for lighting controls can all be configured. (See the Lighting control section.)

RF antenna

The RF antenna allows communication via RF technology. It should not be covered by metal and should be exposed to free air to ensure there is sufficient range.

Infrared (IR) receiver

The infrared receiver serves as a communication portal for the commissioning tools. EasyAir SNS200 with grouping functionality is enabled and commissioned (grouping) by a smart phone with the EasyAir SNS200 IR app.

Motion detector

The occupancy sensor is a PIR (Passive Infrared) sensor that detects movement with an X-Y cross-area under an angle of $X = 72^\circ$ and $Y = 86^\circ$. Two types of movements can be defined:

- Major movement: movement of a person walking into or through an area.
- Minor movement: movement of a person sitting at an office desk reaching for a telephone, turning the pages in a book, opening a file folder, picking up a coffee cup, etc.

When installed in a typical office ceiling at H, the sensor is sensitive to minor movements within $X1$ by $Y1$ area. It will respond to minor movements down to a few centimeters at the task area of a desk and is sensitive to major movements within a range of $X2$ by $Y2$. The maximum recommended height to place the sensor in the ceiling is 3 m to assure movement coverage and detection. The PIR sensor reacts on movement by means of a temperature difference, such as the human body temperature versus its surrounding temperature. A car that just starts its engine is not seen by the PIR nor does the PIR see people sitting within the car or a forklift truck. Therefore, it is recommended not to use EasyAir SNS200 in outdoor, parking or industrial applications. Please refer to the EasyAir SNS200 datasheet for coverage area details. Therefore, it is recommended not to use EasyAir SNS200 in outdoor, parking or industrial applications. Please refer to the EasyAir SNS200 datasheet for coverage area details.

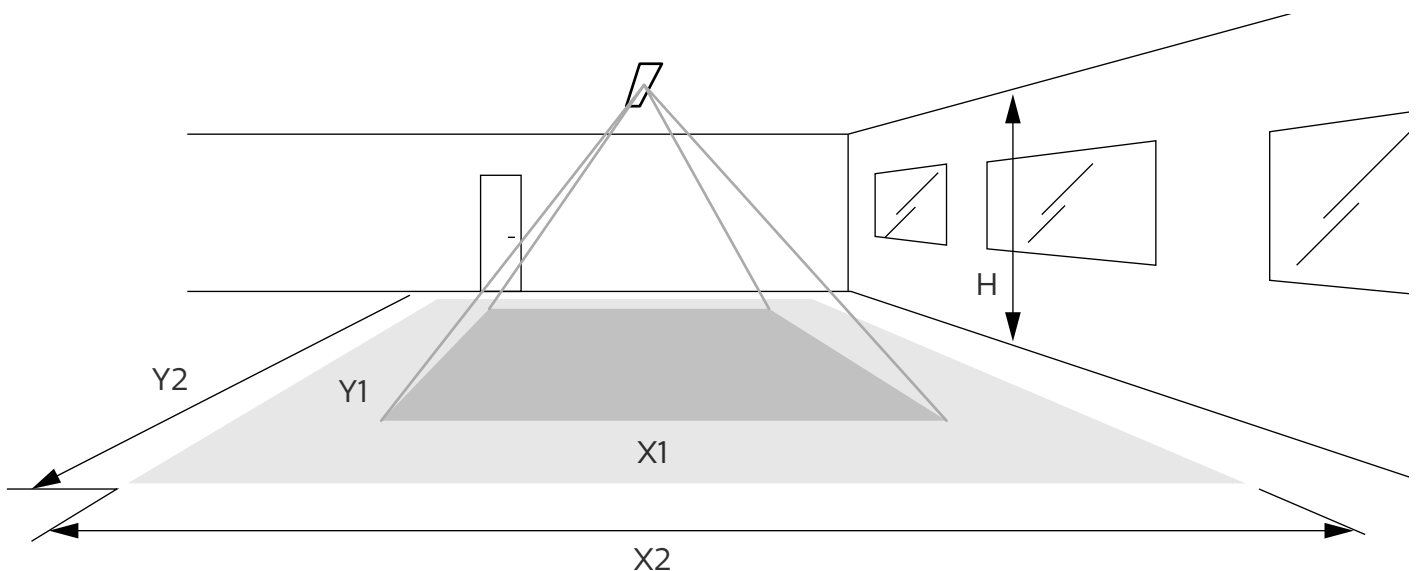
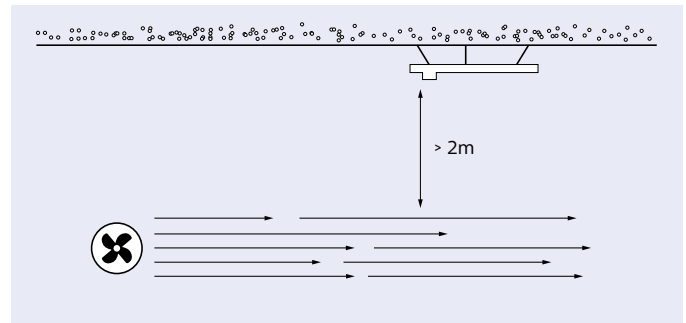
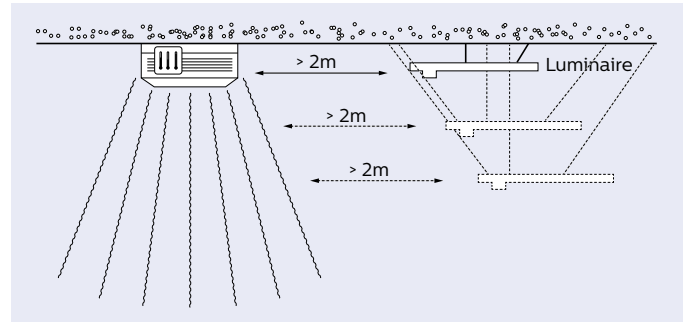

Figure 1. Motion detection area. H: ceiling height. Minor movement detection area: $X1$ by $Y1$. Major movement detection area: $X2$ by $Y2$.

To prevent false triggers, the EasyAir SNS200 must be mounted more than 2 meters away from air vents in all directions, see figures below:



Sensor view shield

The sensor comes with an occupancy view shield that can be used to block the movement detection by the sensor in a certain area. The shield comes inverted. (See Figure 2.) This view shield can be pulled out, flipped and inserted back in the sensor and then rotated so the correct area is shielded off from the detection area. If such shield is not needed in the application, it can be easily pulled out from the sensor or left inverted.

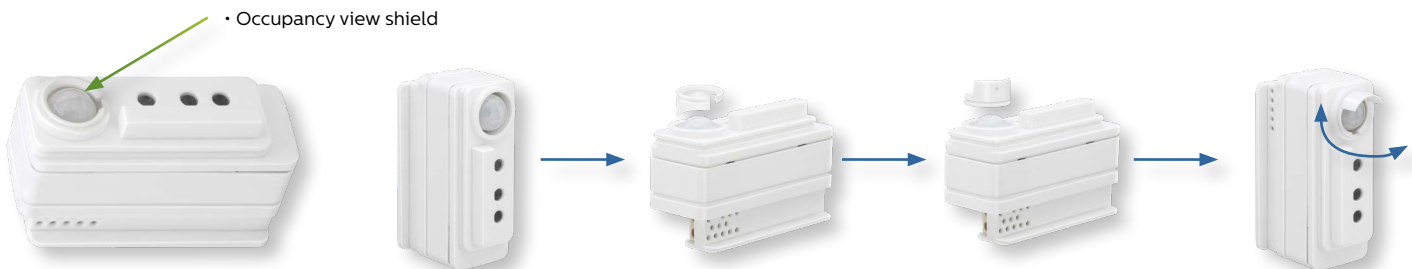

Figure 2. Sensor view shield.

Light sensor

The light sensor is a photo diode that reads average light level captured under an angle of approximately 40°. The intensity of the illuminance depends on the amount of artificial and/or natural light supplied in the office, as well as how this light is reflected toward the ceiling/sensor. The EasyAir SNS200 converts the illuminance signal into ON/OFF or dimming commands to the Philips Xitanium SR LED driver in order to maintain a constant light level on the desk.

The sensor should be installed with a minimum distance of 0.6 m to the window to avoid the sensor looking outside. When the sensor is mounted too close to the window it will look partly outside. Sun reflection from cars or snow can reflect directly into the sensor. The sensor will then measure such high illumination levels that it will drive the artificial light to its minimal level or even switch off the artificial lights. The optimum distance [Y] from the window to EasyAir SNS200 can be obtained from Figure 4. This graph shows the relation between the distance from the window to the sensor [Y] and the height [H] of the sensor (H, height of the sensor measured from ceiling to bottom of window sill).

LED indicator

The product contains a LED indicator. This is enabled by default, and it can be disabled through the app. The behavior of the LED is as follows:

Yellow LED on: = vacancy & light sensor are functional.

Red LED on: = motion is detected and hold time is not expired yet.

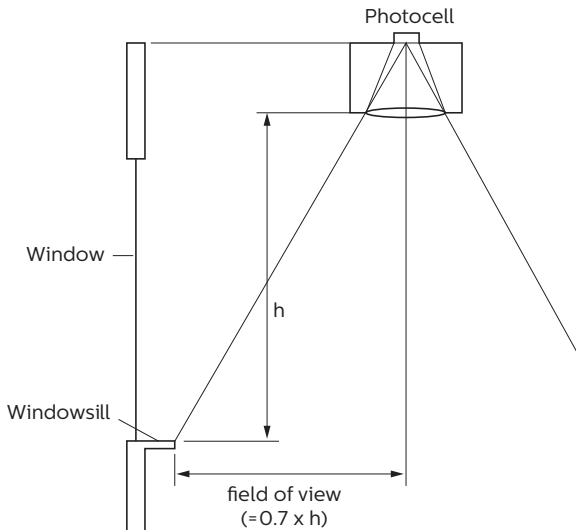

Figure 3. Sensor placement.

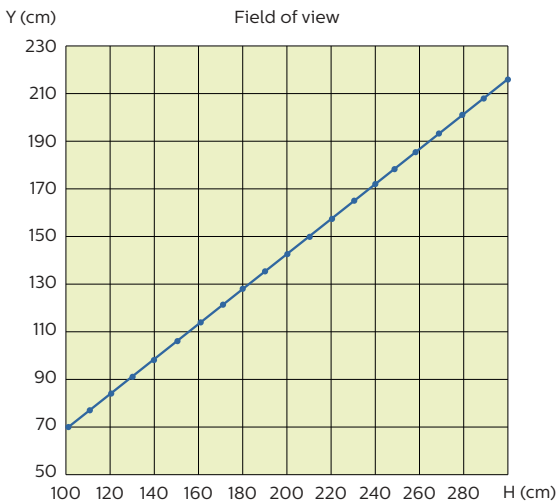

Figure 4. Sensor mounting height from window sill (Y) vs. sensor horizontal distance from window sill (H).

Daylight calibration and System startup behavior

Daylight Calibration

- 1) The daylight calibration allows the sensor to dim down the light levels when there is enough daylight available. The sensor comes in with an assigned value from the factory as a calibration setpoint.
- 2) Every time the device is powered up, a new sample for the calibration setpoint is gathered and stored by the sensor following the current step (auto calibration):
 - Light is switched on at maximum light level set by max of AOC (adjustable output current of the driver).
 - Light dims down to minimum dimming level.
 - Sensor stores the value detected by the light sensor.
 - Light dims up to maximum light level, which is set by the field task level.
 - Sensor stores the value detected by the light sensor.
 - A calculation is executed, and calibration set point will be adjusted.
 - Light dims down to the task level that meets the set point
- 3) The calculation for adjusting the calibration setpoint is determined as the average of last 5 samples with the following assumption - maximum light output of the luminaire in a completely dark environment (i.e. no contribution from ambient light source such as Sun) provides the desired lux level on the desk.
- 4) The daylight calibration adjusts to task level. When a user changes task level via the app, he must power cycle the sensor 5 times to reflect the change in calibration setpoint.

Note: The group control/commissioning is not affected by power cycling. In an application, the way of working could be as follows:

- Install luminaires
- Commission the sensors in groups
- Add switches if any
- Configure settings such as field task level, hold time, etc.
- Power cycle all the luminaires together 5 times to adjust them to application lighting to determine the new setpoint.

System startup behavior

When the sensor is powered (mains of driver is switched on or a momentary power dip is detected by the sensor), the sensor performs an auto-calibration routine as described above.



Warning:

Make sure no objects are blocking the sensor's view and no surface reflectance changes occur in the sensor's view during auto-calibration.

Lighting control

EasyAir SNS200 enables stand-alone LED lighting systems with integrated occupancy sensing and daylight harvesting. Grouping control is actiated through the Philips field app (EasyAir SNS200 IR) and adding wireless switches to the group. In addition to easily adding user control to a space, the grouping feature facilitates auto-off/manual-on use cases. Furthermore, advanced grouping allows scene setting (e.g., presentation mode for a conference room), as well as occupancy sharing (i.e., luminaires within a group can be programmed to remain at prescribed light levels so long as occupancy is detected anywhere in the group).

Terminology used in this chapter

All parameters are stored in the sensor, and most of the parameters can be configured through NFC or IR.

- Fade to switch on/off time
- Hold time
- Grace fading time
- Prolong time
- Field task level
- Background level
- Occupancy mode selection
- Eco-on level
- Group occupancy sharing (SNS200 or higher)
- Group light behavior (SNS200 or higher)
- Daylight based control
- Daylight dependent switching
- Daylight dependent override

Fade to switch-on time is the time (T1 to T2) from the point at which occupancy is detected until the lights dim up to the max light output. This timer is set to 0.7 sec and is not configurable.

Hold time is the time (T3 to T4) from the point at which the last movement has been detected (e.g., occupant left the room) until grace time starts. This timer is set to 15 minutes by default and can be configured from to 1 – 120 minutes.

Grace fading time is the time from T4 to T5 during which the lights are being dimmed down from the current light level to the background level. By default, grace fading time is 10 sec and can be configured to 0 – 25 seconds..

Prolong time is the time from T5 to T6 at which the background level is maintained at a fixed level. Default prolong time is 15 minutes and can be configured from 0 – infinity.

Fade to switch-off time is the time (T6 to T7) for the lights to fade from background level to off after prolong time is expired. This timer is set to 0.7 sec and is not configurable.

Field task level is used to configure the required light level on the task plane. Setting this to 100% enables the installed maximum light level. A lower percentage level can be configured to set the new maximum light level of the luminaire through the app. (See Task tuning.)

Eco-on level is a configurable switch-on light level. This parameter also enables partial-on occupancy based control to meet energy code. Eco-on level should be a percentage level between the field task level and background light level.

Background level is a light level significantly lower than 100%, used to save energy when space is not occupied.

Occupancy mode selection can be configured to maximize control flexibility with adding wireless switches. The mode options are auto-on/auto-off, manual-on/manual-off and manual-on/auto-off.

Group occupancy sharing is a configurable feature to allow EasyAir SNS200 to share its local occupancy detection status and control lights accordingly. As long as presence is detected within the group, the luminaires stay on at the background light level in non-occupied areas.

Group light behavior is a configurable light level for the luminaires in non-occupied areas while there is occupancy detected elsewhere in the group. Lighting control overview.

Occupancy-based lighting control

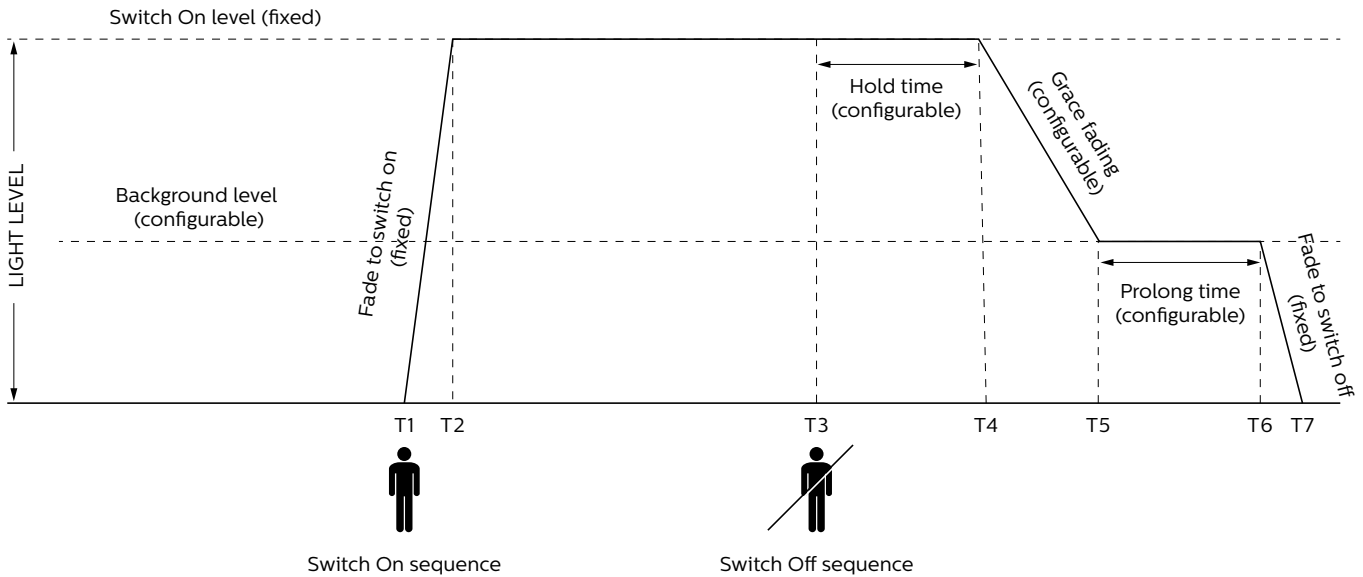

Auto-on/off mode: Lights are switched on and off automatically based on occupancy detection and time delay settings.

Manual-on/auto-off: Lights are turned on manually through a wireless switch and turned off automatically, as a vacancy sensor.

Manual-on/off: Lights are turned on and off manually through a wireless switch while occupied.

Task tuning

Field task tuning is a feature to reduce the maximum output of a luminaire to a certain percentage of the AOC (adjustable output current) of the driver. After installation, there is a possibility that the task light level is not set according to the end user needs (light level too high). Task light level can be adjusted by the installer or building maintenance personnel to a value between 5% and 100% of the max setting through the app..

Occupancy-based lighting control is enabled by default for the EasyAir SNS200, and it can be disabled using an app through NFC.

Daylight harvesting

Daylight-based control is enabled by default. The light sensor auto-calibrates when power to the driver is cycled. The light level of the luminaire is bound by field task level (maximum light level) and background level (minimum light level). If the background light level is set to be 20%, during daylight harvesting, the light will only dim to 20%.

Daylight-based control is not active after hold time of the occupancy sensor expires. Figures 6 and 7 show examples of lighting control using both daylight and occupancy. In both figures, eco-on level = field task level. If eco-on level is lower, then the maximum light level will be the eco-on level. When the daylight level is low (Figure 6) and an occupant is present, the luminaire light level is the field task level minus the daylight level. Assuming the incoming daylight level is constant, luminaire light level remains the same until hold time expires, then it will fall to the background light level. When the daylight level is high, the luminaire light level is the field task level minus the daylight level. However, when there is an abundance of daylight, the luminaire light level does not dim lower than the background light level (Figure 7).

Low daylight level

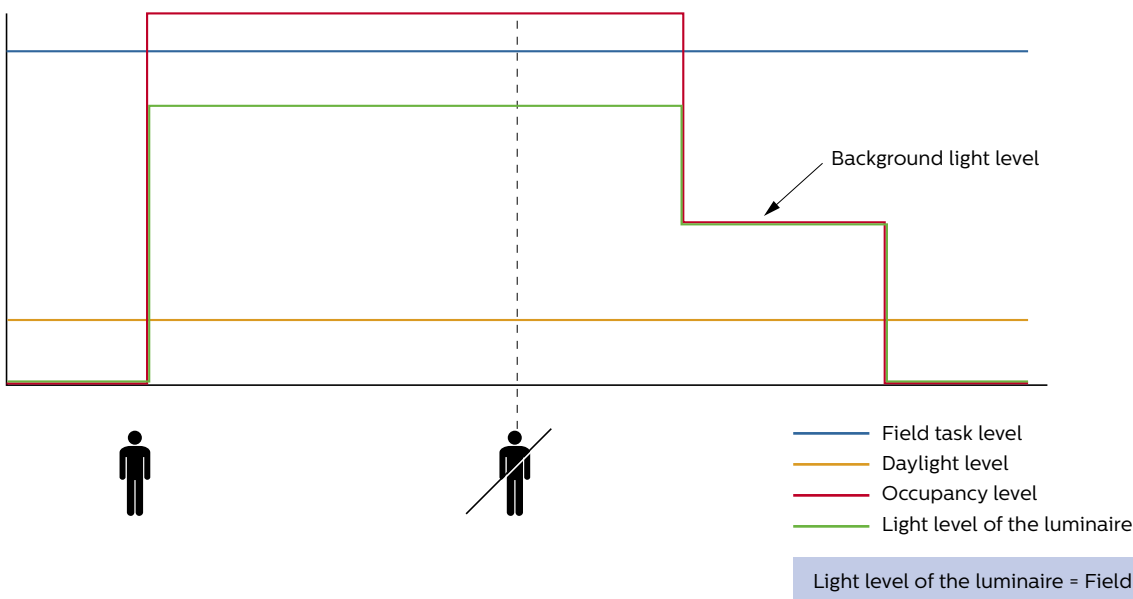

Figure 6. Lighting control behavior with low daylight level.

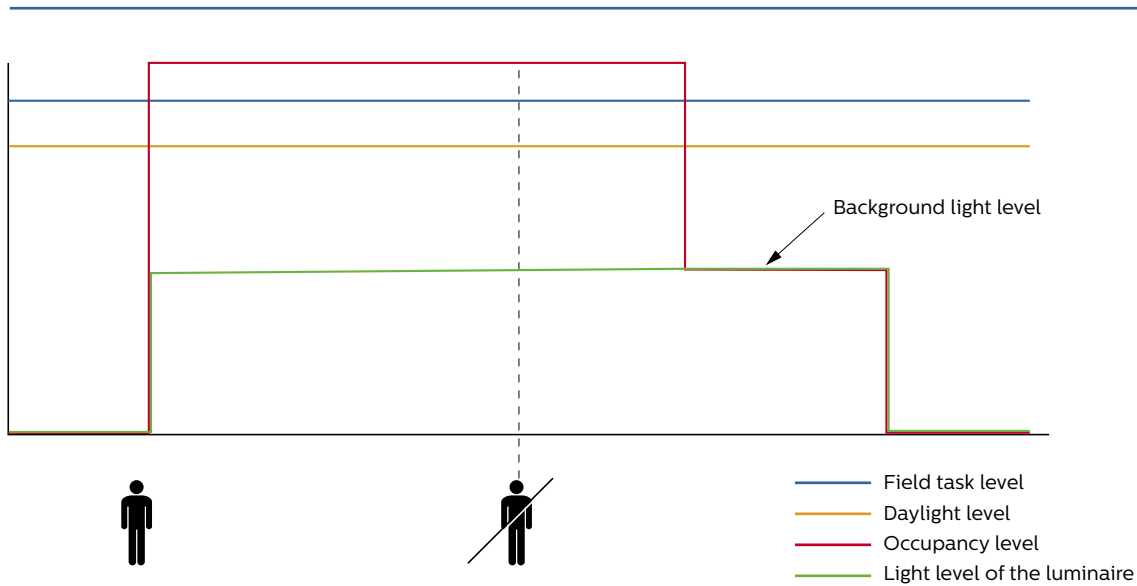

Figure 7. Lighting control behavior with high daylight level.

Daylight dependent override

When daylight based control is enabled (by default) and if occupancy is detected, the luminaire(s) remains always switched on at the calibrated light level based on daylight harvesting as discussed above. In case enough daylight is available, this leads to the reduction of unnecessary energy costs. With Daylight dependent override (DDO) functionality, in the presence of sufficient daylight along with occupancy detection, the luminaire(s) will not switch on until the daylight levels become insufficient i.e. below the daylight regulation setpoint. From that moment, the output light levels are switched on and adjusted to compensate the lack of daylight. In this way, energy costs are reduced. In other words, when DDO is enabled, the sensor keeps the lights switched off while maintaining enough light in the room for the end user when:

- the lights were initially switched off due to a vacant room and
- presence, either local or elsewhere, was detected and
- an “Auto On/Off” occupancy mode has been configured and
- the measured light level is higher than 150% of the daylight regulation setpoint.

When the measured light level drops below the daylight regulation setpoint, the lights switch on again.

DDO is disabled when:

- either of the occupancy mode “Manual On/Auto Off” or “Manual On/Off” occupancy mode is selected or
- Daylight based control is disabled.

DDO has the following dependencies to work effectively:

- Daylight based control **Enabled**;
- Occupancy Mode set to **Auto On/Off** and;
- Prolong time not infinite;

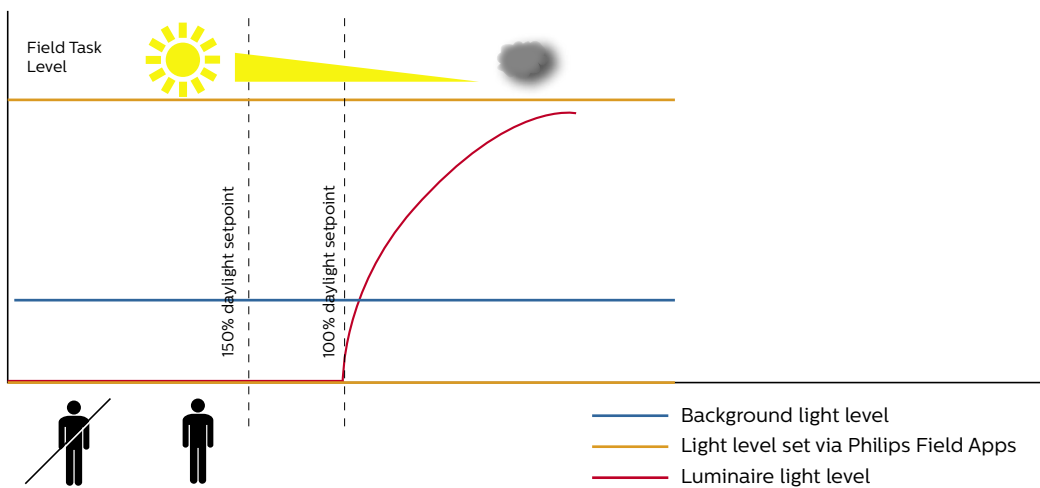

Lighting control behaviour with Daylight dependent override (DDO)

Daylight dependent switching

When daylight based control is enabled (by default) and as long as the occupancy is detected, the luminaire never switches off the light. Even at the brightest daylight levels, the luminaire dims down to background light level; this leads to the reduction of unnecessary energy costs.

With Daylight dependent switching (DDS) functionality, if there is enough daylight the sensor switches off the luminaire leading to lower energy costs.

The sensor switches off the light when:

- the luminaire is already switched on and
- an “Auto On/Off” occupancy mode has been configured and
- the measured light level on the local sensor is above the threshold value (150% of the daylight regulation setpoint) for more than 15 minutes and

The 15 minutes is reset as soon as one of the above conditions is not met. The fade time for turning off the light is ~30 seconds.

The sensor switches on the luminaire(s) when:

- the light level on the local sensor is below the daylight regulation setpoint and
- there is presence, either local or elsewhere, detected in the room

A “Manual On” request overrides DDS, the luminaire(s) switch on and the 15 minutes is reset. This is because the user expects light behavior when pressing a button manually.

DDS is disabled when:

- either of the occupancy modes “Manual On/ Auto Off” or “Manual On/Off” occupancy mode is selected or
- Daylight based control is disabled.

DDS has the following dependencies to work effectively:

- Daylight based control **Enabled**;
- Occupancy Mode set to **Auto On/Off** and;
- Prolong time not infinite;

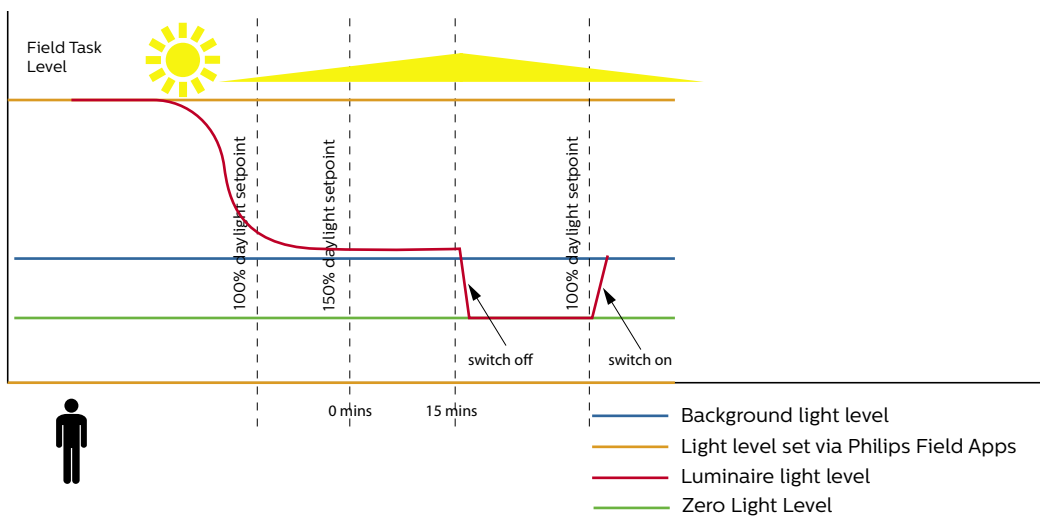

Lighting control behaviour with Daylight dependent switching (DDS)

Occupancy sensing

Switch-on/off sequence

If occupancy is detected, lights are dimmed up to the eco-on light level in 0.7 second. When occupancy is not detected anymore, the following lighting switch-off sequence is executed: the sensor will wait until the hold time is expired and then the light fades the background level in grace fading time. The light level is kept at the background level for prolong time. After prolong time expires, the light fades from the background level to off in 0.7 second.

Occupancy-based lighting control is enabled by default for the EasyAir SNS200, and it can be disabled using an app through NFC or IR.

Use Case

Max rating of the luminaire: 4000 lm

The user configures the sensor parameters through Philips Field Apps:

Task tuning level	80% = 3200 lm
Eco-on level	70% = 2800 lm
Background light level	20% = 800 lm
Min dimming level of driver	5% = 200 lm

Note: All percentage levels refers to the max rating of the luminaire. The full dimming range of the luminaire is bounded by task tuning and min dimming level. By setting field task tuning = 80% and with driver minimum dimming level = 5%, the luminaire light output range is 3200 lm to 200 lm. The automatic lighting control range is 2800 lm to 800 lm by setting the eco-on level to 70% and background light level to 20%. However the wireless switch can be used to control the full dimming range of the light (3200 lm - 200 lm).

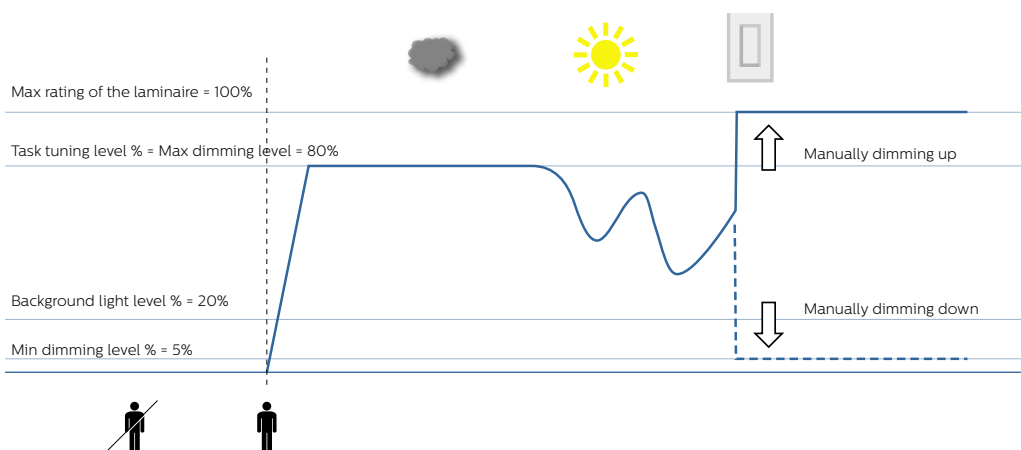

Figure 8. Automatic lighting control with manual dimming override.

Manual dimming override

Light level can be tuned into any level between max (task tuning level) and min (minimum dimming level of the LED driver) by pressing the dimming up and dimming down button of the switch.

- Light level can be set to an intermediate level by manual dimming override using the wireless switch. When a manual dimming override is performed, daylight-based control is disabled, and light will be on constantly at this level. When the room becomes unoccupied, the light goes to the background light level during prolong time, and if the occupant enters the room before prolong time expires (Figure 10), the light will stay at the level set by the manual dimming override. If the prolong time expires, the light will turn off and go to the eco-on light level when occupant enters the room (Figure 11).

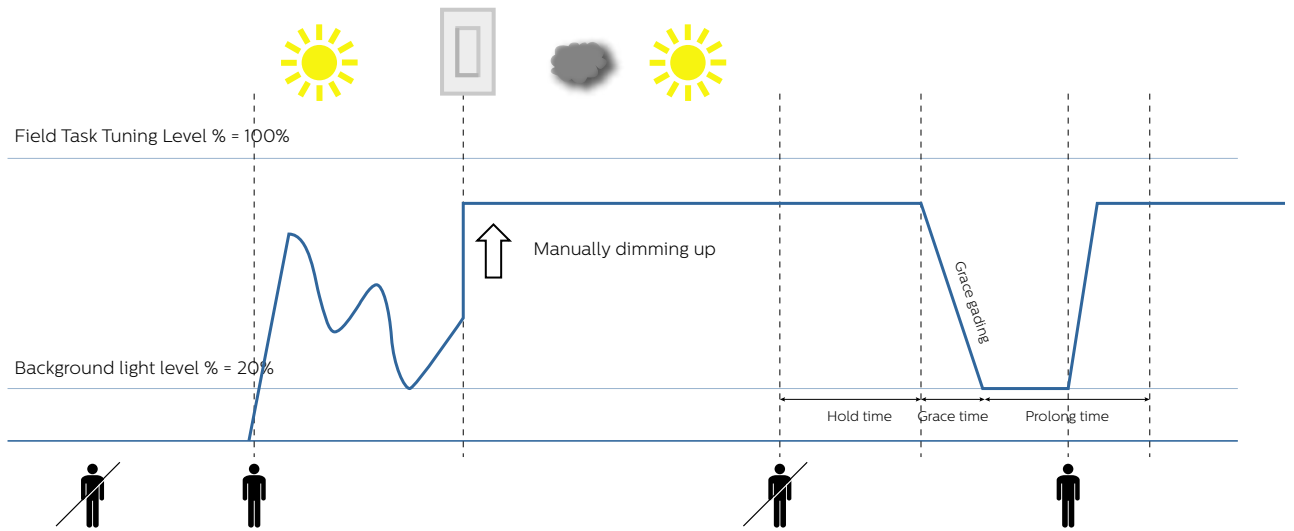

Figure 10. Auto-on/auto-off with manual dimming override.

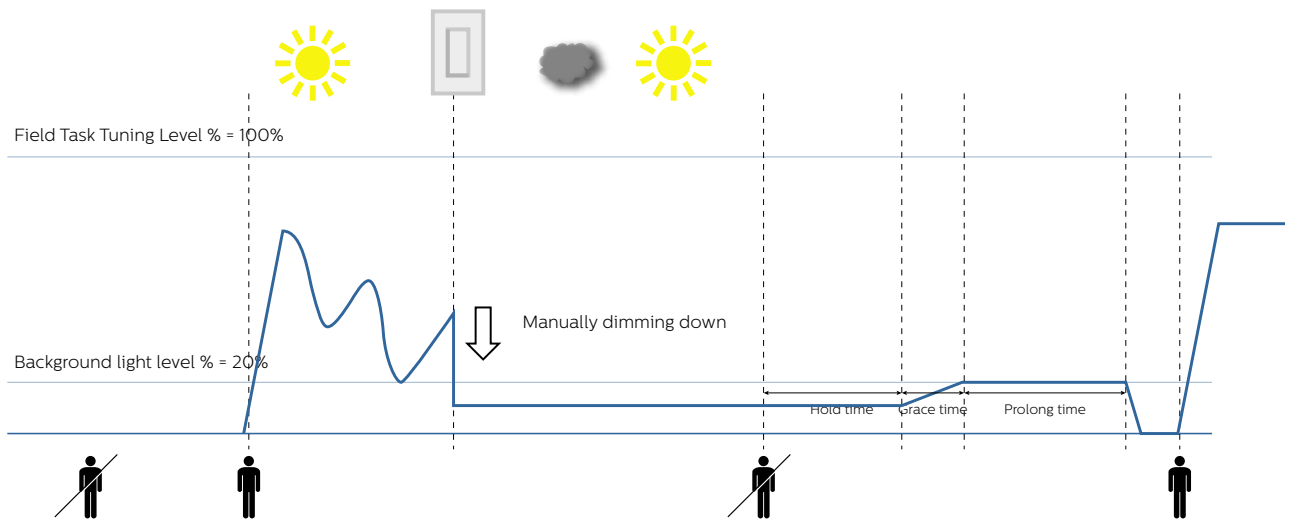

Figure 11. Auto-on/auto-off with manual dimming override.

Group occupancy sharing (SNS200 and future generations)

The traditional approach to energy savings in open plan is wattage reduction, which often results in light levels below recommended practice. Luminaires with standalone lighting controls create so-called chess board look on the ceiling. Philips EasyAir SNS200 overcomes these problems with smart luminaires that provide full light output at occupied workstations and lower background light levels at unoccupied workstations. The aesthetic of the space is maintained with a background light level that won't turn off luminaires until the entire wireless group is unoccupied.

The group occupancy sharing feature can be enabled (default)/disabled through the Philips Field Apps. The group lighting behavior can also be configured to background light level or task light level. With the group occupancy sharing disabled, the luminaire does not share its occupancy status with other luminaires or respond to the occupancy detection from the rest of the group.

After installation, a large lighting group of up to 40 luminaires can be created easily and quickly using the Philips Field Apps. With default settings, as long as occupancy is detected by any luminaire in the group, those luminaires are turned on at task level while the rest of luminaires in non-occupied areas of the group stay on at the background light level.

Note: During the group occupancy sharing, daylight harvesting occurs automatically.

Beside is an example of the group occupancy sharing behavior in an open office application.

An open office application

As people enter, lighting in their area dims up to "task level." Others in the group dim up to "background level."



Figure 12. Open office application.



Figure 13. Light adjusts as room occupancy changes.



As additional people enter, lights in their area dim up to “task level.”

October 2019

Figure 14. Lights dimming up.



As more workers enter, the lights dim up accordingly.

Figure 15. Lights dimming up.



When the space is fully occupied, all lights are on “task level.”

Figure 16. Light at “task level.”



As people go to lunch or meetings, lights gently dim down to a configured “background level.”

Figure 17. Light adjusts to “background level.”



Figure 18. Additional light dims.

As people begin leaving for the day, additional lights dim down.



Figure 19. Light dims.

As the space empties, more lights dim down to to the background.



Figure 20. Light turns off.

After the last worker leaves, lights turn off after a configured “prolong time.”



Figure 21. Light turned off.

Lights turn off after a configured “prolong time.”

Scene setting (SNS200 and future generations)

Light settings for meeting and conference rooms need to be flexible to fulfill a variety of situational requirements. For example, audiovisual presentations may require lower light levels near the screen versus a regular meeting requiring uniform lighting on the task level. EasyAir SNS200 together with wireless switches and the Philips Field Apps, enables easy lighting configuration remotely for two scenes after the installation. (See app user manual for details to configure scenes.)

- The wireless switch comes with four buttons.
- Top left button: On/Dim-up
- Bottom left button: Off/Dim-down
- Top right button: Scene 1
- Bottom right button: Scene 2

Once a scene button is pressed, the group of lights goes to the preset light level and does not respond to daylight variation any longer.

A conference room for presentations

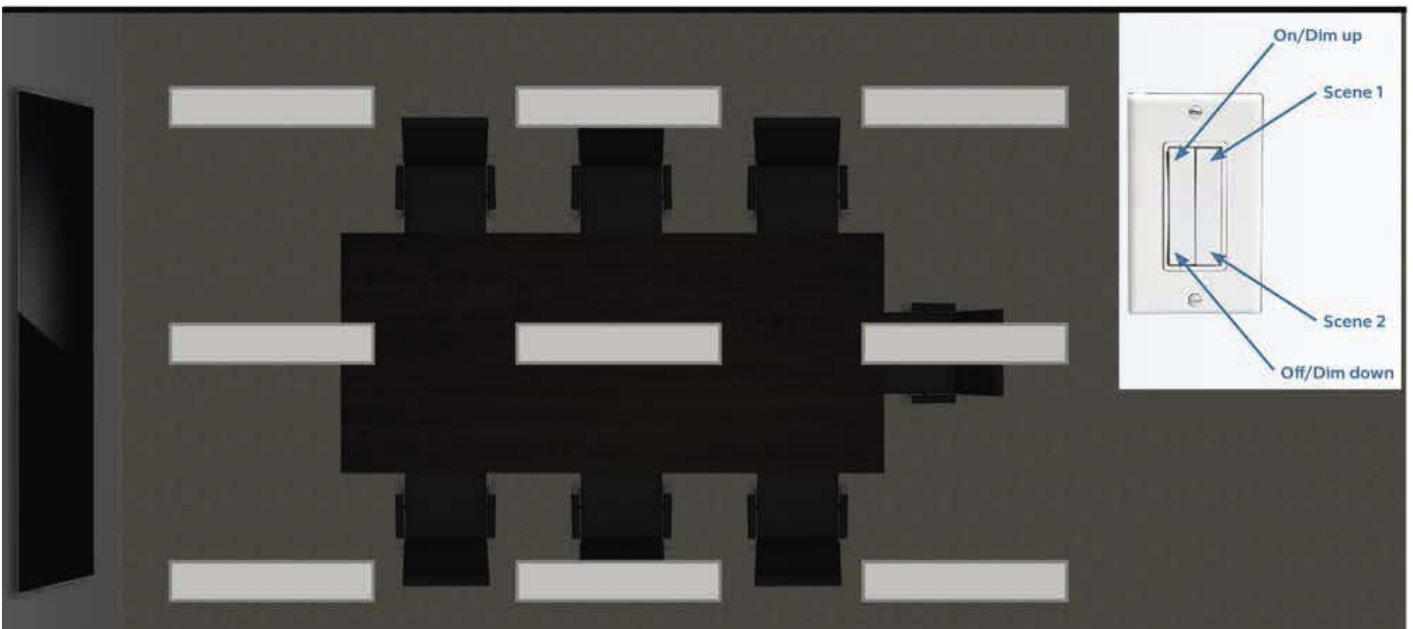
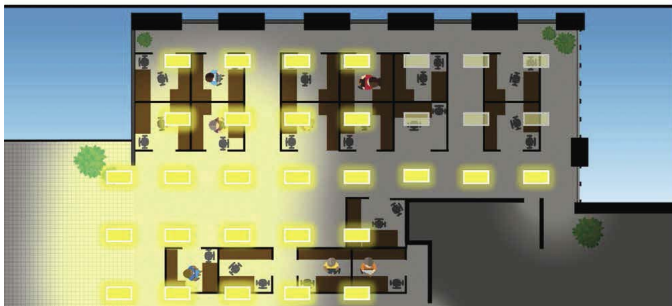

Figure 22. Conference room application.



Pressing “ON” brings lights to “task level.”



Pressing “Scene 1” takes lighting to pre-defined “presentation level.”

Figure 23. Conference room at “task level.”

Figure 24. Conference room at “presentation level.”

Phone-based app and configuration

There are two apps available for configuring and commissioning (grouping) EasyAir SNS200 with NFC and IR blaster functionality: EasyAir SNS200 NFC and EasyAir SNS200 IR. EasyAir SNS200 IR app can be used with EasyAir SNS200 and future generations.

Phone requirement: The Philips Field Apps works only on Android-based smart phones. Check the EasyAir SNS200 website for the latest list of compatible phones and their NFC reader locations.

The app can be downloaded from the Google Play store. This is a B2B app requires authentication with user ID and password. Please register at www.lighting.philips.co.uk/oem-emea/products/easy-to-integrate-wireless-sensors.html to obtain user id and password.

Various sensor parameters can be configured through the app. Please check the latest user manual at www.lighting.philips.co.uk/oem-emea/products/easy-to-integrate-wireless-sensors.html for information on using the app with EasyAir SNS200. The configuration range of each parameter is listed in the EasyAir SNS200 datasheet.

List of supported switches

Starting version 1.0.0.6 of Philips Field Apps, the following switches are supported for different versions of EasyAir SNS200.

Refer the table below for details:

Switch Brand	Type, Identifier	EnOcean Module	Release Status
Philips	UID8450/10 Single Rocker	PTM215Z	Supported
	UID8460/10 Dual Rocker	PTM215Z	Supported (Limited functionality – no dimming)*
	Hue Tap	PTM215Z	Supported (Limited functionality – no dimming)
Jaeger Direkt	Single Rocker	PTM215ZE	Supported
	Dual Rocker	PTM215ZE	Supported
Vimar	Dual Rocker	PTM215ZE	Supported
Legrand	Single Rocker	Info not available	Supported
	Dual Rocker	Info not available	Supported

Note: A Single Rocker/ Dual Rocker switch may also be known as 2 button /4 button switch respectively.

Note: For information on commissioning procedure for each switch, please refer our website.

* If a long press is made on Philips UID8460/10, it is susceptible to channel change.

Mechanical design-in

Wire strip length

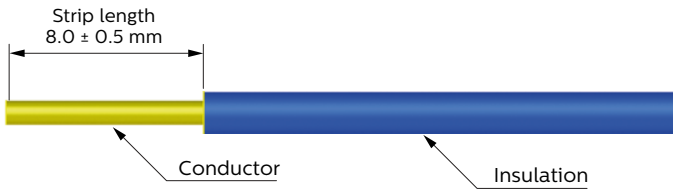

[Conductor: Bare Copper / Strand wire]

Wire insertion

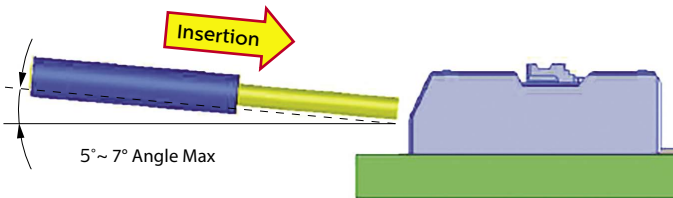

[Inserting solid conductors via push-in terminal]

Wire separation from the connector

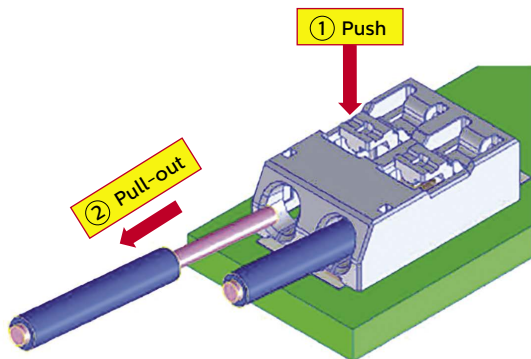

Wiring Information

Applicable wires

Wire Range AWG#	Number of Conductors /		Conductor Type
	Diameter of a Conductor (Number of Conductors / mm)	Insulation Diameter (mm)	
24	1 / 0.51 (0.2 mm ²)	1.35	Solid
22	1 / 0.64 (0.3 mm ²)	1.48	
20	1 / 0.81 (0.5 mm ²)	1.65	
18	1 / 1.02 (0.8 mm ²)	1.86	
22	17 / 0.76 (Reference) After Soldering: ø0.9 mm Max.	1.60	Strand
20	21 / 0.95 (Reference) After Soldering: ø0.9 mm Max.	1.78	

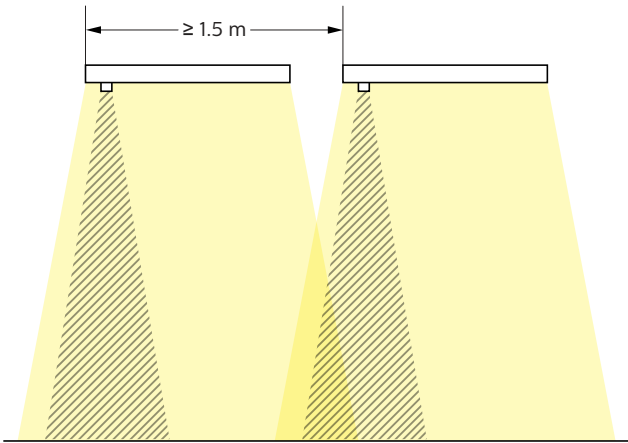

Wire distance for remote mounting

It is recommended to keep the wire distance from sensor to Xitanium SR LED driver less than 15 m and meet the wire gauge requirement to guarantee the performance.

Sensor position If multiple luminaires are used in the same area, the distance between the different sensors should be at least 1.5 m. This distance will minimize a sensor from “seeing” the light variation of other luminaires and reacting.

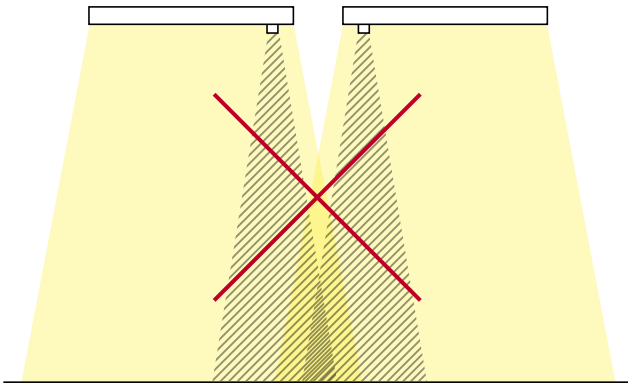
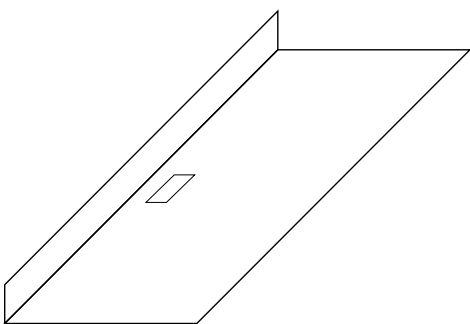
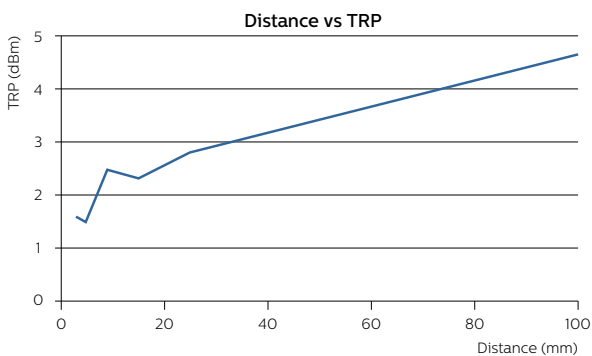

Figure 25. Distance between sensors should be at least 1.5m apart.



Recommendations to design-in a luminaire around EasyAir SNS200 with good RF signal

It is recommended to have one side metal wall distance from EasyAir SNS200 antenna side wall greater than 100mm (assuming other metal walls are far away, see figure below). This would allow luminaire to luminaire distance to be greater than 10 meters.



In general, every dB drop reduces luminaire to luminaire distance by 1 meter. The chart below gives one reference measurement for radiated RF power (TRP) vs. distance from one side metal wall.

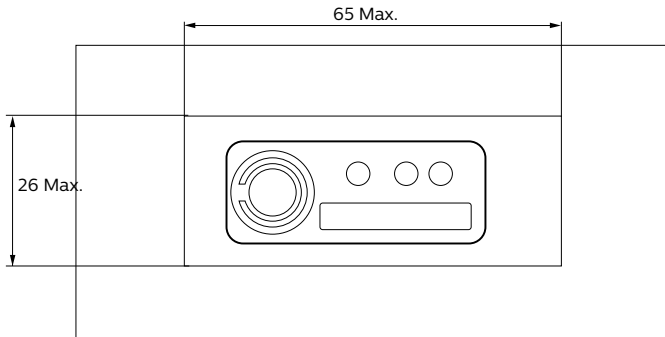

Mounting in a bracket (SMB-50)

The EasyAir SNS200 can be mounted in a bracket (SMB 50). Refer the figures for details on mounting and design-in into luminaire. All dimensions are in mm.

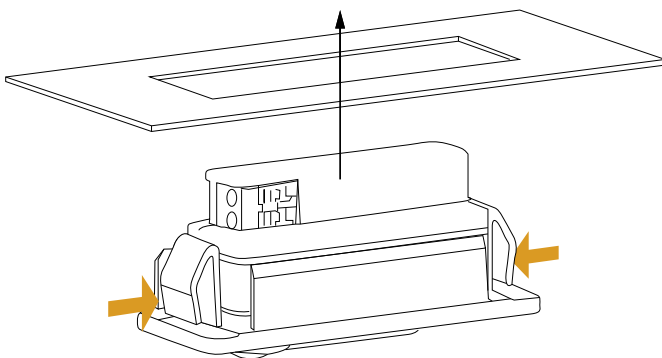
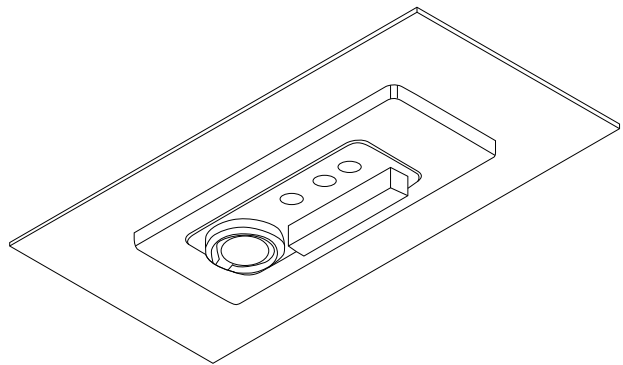
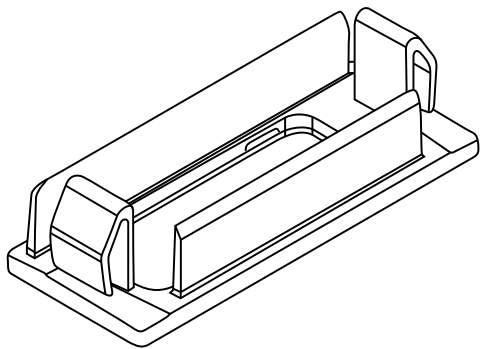
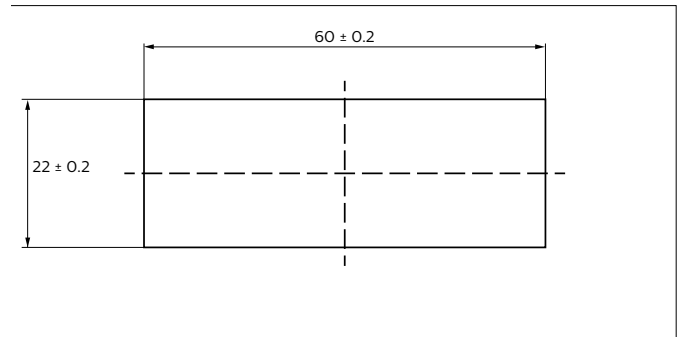
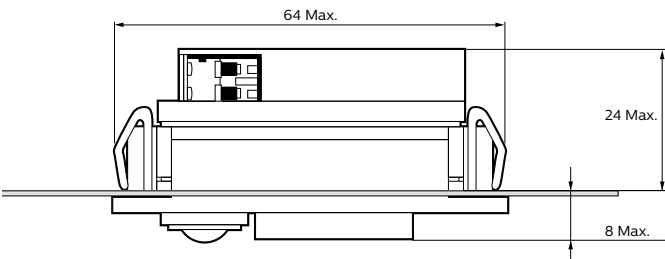

Press springs inwards on both sides before the bracket can slide-in the luminaire hole.

Installing EasyAir SNS200 with ceiling mount bracket (SNS200CMP)

The ceiling mount bracket SNS200CMP is premounted with the EasyAir SNS200 and the cable. The strain relief is already part of the CMP200.

Drill 63.5 mm hole in the ceiling for installation of the SNS200CMP bracket. For more details on cut-out and mounting, refer the figures below. All dimensions are in mm.

Connect the wires from the sensor to the LED Driver in the luminaire. Connect the white wire from the sensor to the SR- terminal and the red wire from the sensor to the SR+ terminal of the SR driver. Follow luminaire manufacturer's instructions for accessing the SR driver.

The EasyAir SNS200 operates upon energization with no further commissioning. See the chapter "Lighting Control" for configuring parameters during or after installation. Refer EasyAir SNS200 App Manual to configure the sensor using the Philips Field Apps.

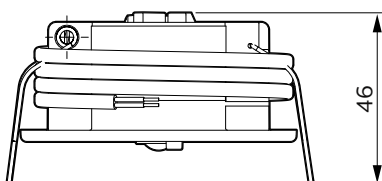
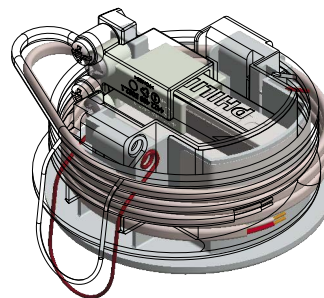
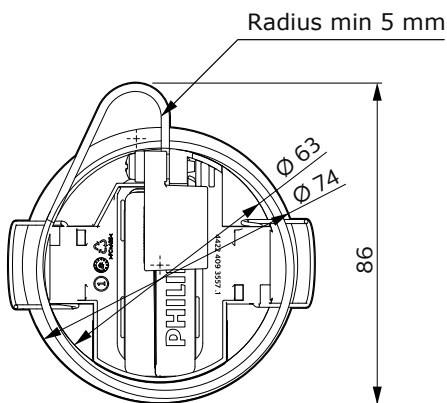
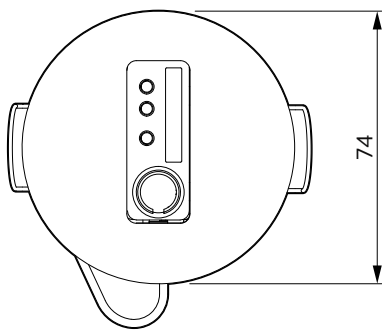

Mounting distance guidelines for EasyAir SNS200CMP

In independent applications where SNS200CMP is used, please refer to below distance guidelines. Please ensure that the wiring from SNS200CMP to SR interface (Xi SR bridge or Xi SR Driver) in an independent application should be less than 2m as SR bus is intended to be used inside the luminaire.

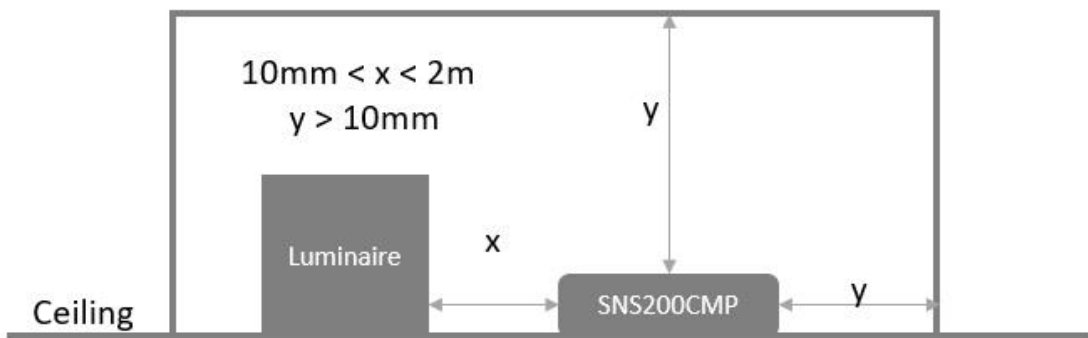

EasyAir SNS200 with multiple Philips Xitanium SR LED drivers (1:N application)

When a group of luminaires is in the same daylight condition and needs to be operated at the same level, it is possible to use one sensor to control multiple luminaires.

The best way to work in such a scenario is to use an SR bridge. An SR bridge can connect to multiple DALI drivers on one end and to the sensor on one end. For more details, please refer the datasheet and design-in guide of SR Bridge available on our website.

EasyAir SNS200 sends commands to all connected drivers (using broadcast command); it does not have capabilities to address individual drivers. The light commands are sent as a broadcast command, so occupancy-/daylight-based lighting control and task tuning operate the same on all connected drivers. The readout of energy information from the connected drivers will not function. The energy readout of multiple drivers is foreseen for future sensor generations.



Warning:

The regular DALI drivers have basic insulation on the DALI interface as safety barrier. The SR drivers / bridge have double insulation on the SR interface. As EasyAir SNS200 devices do not have additional insulation barriers, it means that using DALI drivers via SR bridge maintains the double insulation level.

FAQ

Can you use a wall dimmer with EasyAir SNS200?

SNS200 and higher models can be used with a wireless wall dimmer, e.g., Zigbee green power switch.

How does EasyAir SNS200 compare to Philips ActiLume?

Occupancy sensing and daylight harvesting are similar. Form factors are also similar, with the face of the sensor outside the luminaire having the same size. The portion of EasyAir SNS200 within the luminaire is slightly deeper and longer to accommodate added functionality. EasyAir SNS200 includes institutional tuning plus energy reporting and also works on Philips Xitanium SR LED drivers to eliminate the cost and complexity of a separate power pack. EasyAir SNS200 also performs auto-calibration for daylight (see later Q&A).

Is EasyAir SNS200 a DALI sensor?

EasyAir SNS200 works with Philips SR LED drivers, which use DALI to communicate between driver and sensor. This is the same principle as other SR-certified devices, therefore, EasyAir SNS200 is not a DALI sensor.

Can I use EasyAir SNS200 outside a luminaire?

An accessory option is available to enable ceiling mount. Wiring to the driver must be managed similar to other external mounted sensors. Because EasyAir SNS200 is low-voltage class 2, this is easier than with many other sensors.

Can I use one sensor with multiple luminaires?

Yes, and the ceiling mount option is likely utilized in this use case (called 1:N operation as opposed to 1:1). It usually means turning off the SR power supplies in all but one of the SR drivers. See EasyAir SNS200 with multiple SR drivers 1:N application section.

Does EasyAir SNS200 do “auto-off/manual-on”?

SNS200 supports auto-off/manual-on functionality via wireless switches. There are use cases in codes that are interpreted to require auto-off/manual-on. The auto-off/partial-on mode can be supported by eco-on.

Does EasyAir SNS200 make sense if I only want to do occupancy sensing?

Yes. Most occupancy sensors run on high voltage or require an extra power pack, adding cost and complexity. Typical wallplate-style occupancy sensors – while mass produced and inexpensive – vary in performance by use case since the viewing angle from a wall is less than ideal. Also, the relay-free operation of EasyAir SNS200 makes it inherently more reliable. And traditional occupancy sensors are bulky

How does the daylight harvesting feature work?

EasyAir SNS200 does auto-calibration when the luminaire is first powered. See the system startup behavior/auto-calibration section for details. Electric lighting will not reduce below the programmed background light level regardless of daylight availability. Traditional sensors lacking auto-calibration are either pre-set with an assumed task light level or require manual calibration during commissioning.

Is EasyAir SNS200 “failsafe”?

Unlike traditional occupancy sensors, EasyAir SNS200 does not have a mechanical relay. This is a benefit of Philips SR LED drivers, as on/off is done relay-free within the driver. Devices with mechanical relays should be designed so that relay failure results in “lights on.” If an SR driver does not see a digital signal from a device for a long period of time (e.g., loose connection, sensor failure), the driver goes to full programmed output.

How do mixed systems with different versions of EasyAir SNS200 work?

Only 1 version of EasyAir SNS200 is available now. Earlier versions such as SNS100 or SNS102 are phased out.

Contact details

Philips EasyAir SNS200

Product information:

www.lighting.philips.co.uk/oem-emea/products/easy-to-integrate-wireless-sensors.html

Or contact your local Philips sales representative.

Disclaimer

Note that the information provided in this document is subject to change.

This document is not an official testing certificate and cannot be used or construed as a document authorizing or otherwise supporting an official release of a luminaire. The user of this document remains at all times liable and responsible for any and all required testing and approbation prior to the manufacture and sale of any luminaire.

The recommendations and other advice contained in this document, are provided solely for informational purposes for internal evaluation by the user of this document. Philips Lighting does not make and hereby expressly disclaims any warranties or assurances whatsoever as to the accuracy, completeness, reliability, content and/or quality of any recommendations and other advice contained in this document, whether express or implied including, without limitation, any warranties of satisfactory quality, fitness for a particular purpose or non-infringement. Philips Lighting has not investigated, and is under no obligation or duty to investigate, whether the recommendations and other advice contained in this document are, or may be, in conflict with existing patents or any other intellectual property rights. The recommendations and other advice contained herein are provided by Philips Lighting on an “as is” basis, at the user’s sole risk and expense.

Specifically mentioned products, materials and/or tools from third parties are only indicative and reference to these products, materials and/or tools does not necessarily mean they are endorsed by Philips Lighting. Philips Lighting gives no warranties regarding these and assumes no legal liability or responsibility for any loss or damage resulting from the use of the information thereto given here.



© 2019 Signify Holding. All rights reserved. The information provided herein is subject to change, without notice. Signify does not give any representation or warranty as to the accuracy or completeness of the information included herein and shall not be liable for any action in reliance thereon. The information presented in this document is not intended as any commercial offer and does not form part of any quotation or contract, unless otherwise agreed by Signify.

www.lighting.philips.co.uk/oem-emea/products/connected-lighting

Philips and the Philips Shield Emblem are registered trademarks of Koninklijke Philips N.V. All other trademarks are owned by Signify Holding or their respective owners.

01/2019
Data subject to change