

MR16out PROCESSOR

Installation and Specifications:

This device complies with part 15 of the FCC Rules. Operation is subject to the following two conditions: (1) This device may not cause harmful interference, and (2) this device must accept any interference received, including interference that may cause undesired operation.

1. General:

The MR16out processor provides a solution to the OEM system integrator for output control. The controller has 16 form-C contact relays for load switching. Additionally, 2 digital inputs are provided for tamper and power fault status monitoring. The processor requires 12 to 24Vdc for power.

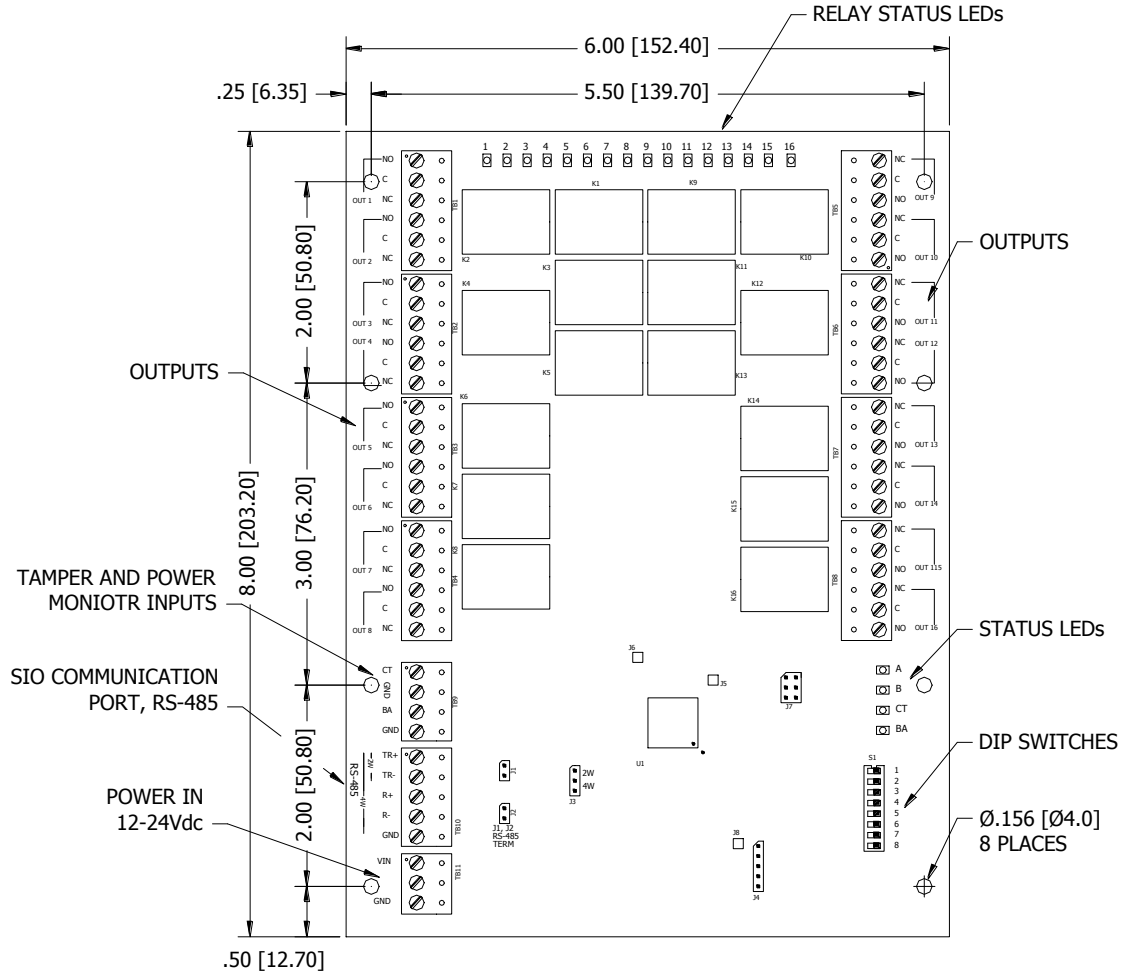

2. Supplying Power to the MR16out:

The MR16out requires 12 to 24Vdc for power on TB11. Locate power source as close to the unit as possible. Connect power with minimum of 18AWG wires.

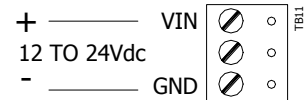

Observe POLARITY on VIN!

3. Communication Wiring:

The MR16out communicates to a controller via a 2-wire RS-485 interface. The interface allows multi-drop communication on a single bus of up to 4,000 feet (1,200 m). Use twisted pair (minimum 24 AWG) with shield for the communication line.

Install the following jumpers for the RS-485 interface according to the selected configuration:

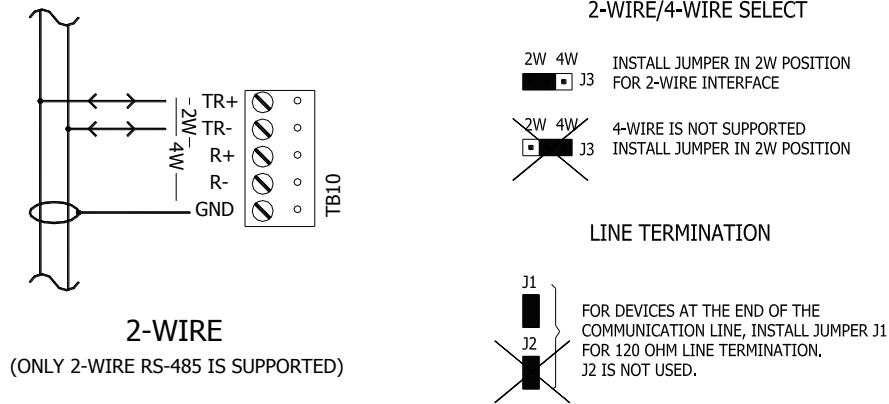

4. Inputs for Cabinet Tamper/Power Fault:

Input CT and input BA are used for monitoring cabinet tamper and power failure with normally closed contacts. These two inputs are for contact closure monitoring only, and do not use EOL resistor(s). If these inputs are not used, install a short piece of wire at the input to indicate a safe condition.

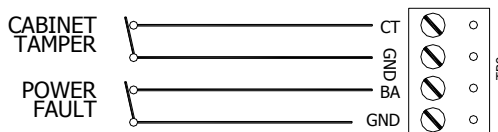

5. Relay Outputs:

The following diagrams show typical use of the relay. A DC power source is recommended whenever possible. Transient clamping must be provided to protect the contacts and to reduce EMI emission. Use sufficiently large wires for the load current to avoid voltage loss.

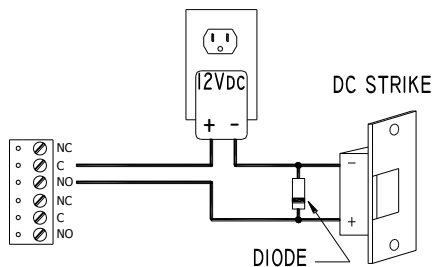

DIODE SELECTION:

DIODE CURRENT RATING > 1 X STRIKE CURRENT
 DIODE BREAK DOWN VOLTAGE: 4X STRIKE VOLTAGE
 FOR 12Vdc or 24Vdc STRIKE, DIODE 1N4002 (100V /1A) TYPICAL

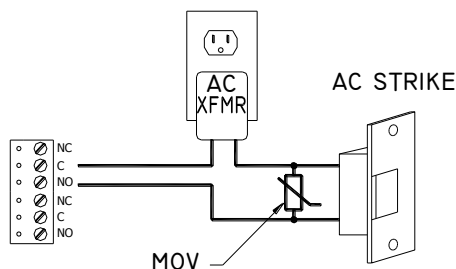

MOV SELECTION:

CLAMP VOLTAGE > 1.5 X Vac RMS
 FOR 24Vac STRIKE, PANASONIC ERZ-C07DK470 TYPICAL

6. DIP Switch and Jumper Usage:

Switches 1 to 5 select the device address. Switch 6 and 7 select the communication baud rate. Switch 8 enables encrypted communication. All other configuration settings are set via host software.

S8	S7	S6	S5	S4	S3	S2	S1	SELECTION
			OFF	OFF	OFF	OFF	OFF	Address 0
			OFF	OFF	OFF	OFF	ON	Address 1
			OFF	OFF	OFF	ON	OFF	Address 2
			OFF	OFF	OFF	ON	ON	Address 3
			OFF	OFF	ON	OFF	OFF	Address 4
			OFF	OFF	ON	OFF	ON	Address 5
			OFF	OFF	ON	ON	OFF	Address 6
			OFF	OFF	ON	ON	ON	Address 7
			OFF	ON	OFF	OFF	OFF	Address 8
			OFF	ON	OFF	OFF	ON	Address 9
			OFF	ON	OFF	ON	OFF	Address 10
			OFF	ON	OFF	ON	ON	Address 11
			OFF	ON	ON	OFF	OFF	Address 12
			OFF	ON	ON	OFF	ON	Address 13
			OFF	ON	ON	ON	OFF	Address 14
			OFF	ON	ON	ON	ON	Address 15
			ON	OFF	OFF	OFF	OFF	Address 16
			ON	OFF	OFF	OFF	ON	Address 17
			ON	OFF	OFF	ON	OFF	Address 18
			ON	OFF	OFF	ON	ON	Address 19
			ON	OFF	ON	OFF	OFF	Address 20
			ON	OFF	ON	OFF	ON	Address 21
			ON	OFF	ON	ON	OFF	Address 22
			ON	OFF	ON	ON	ON	Address 23
			ON	ON	OFF	OFF	OFF	Address 24
			ON	ON	OFF	OFF	ON	Address 25
			ON	ON	OFF	ON	OFF	Address 26
			ON	ON	OFF	ON	ON	Address 27
			ON	ON	ON	OFF	OFF	Address 28
			ON	ON	ON	OFF	ON	Address 29
			ON	ON	ON	ON	OFF	Address 30
			ON	ON	ON	ON	ON	Address 31
	OFF	OFF						115,200 BPS, See note 1 below.
	OFF	ON						9,600 BPS
	ON	OFF						19,200 BPS
	ON	ON						38,400 BPS
OFF								Encrypted communication not required See note 2 below.
ON								Encrypted communication required See note 2 below.

Note 1: Firmware revisions prior to 1.30.1, this setting is 2,400 BPS.

Note 2: Firmware revisions prior to 1.30.1, SW8 is not defined. Set to the OFF position.

Jumpers:

JUMPER	DESCRIPTION
J1	RS-485 termination, install in first and last units only
J2	Not used
J3	2-wire/4-wire select, install in 2W position only
J4	Factory use only
J5	Factory use only
J6	Factory use only
J7	Factory use only
J8	Factory use only
J9	Factory use only

7. Status LEDs:

Power-up: All LED's OFF

Initialization: Once power is applied, initialization of the module begins

When initialization is completed, LEDs A, B, CT, and BA are briefly sequenced **ON** then **OFF**.

Run time: After the above sequence, the LEDs have the following meanings:

A LED: Heartbeat and On-Line Status:

Off-line: 1 sec rate, 20% **ON**

On-line:

Non-encrypted communication: 1 sec rate, 80% **ON**

Encrypted communication:

.1 sec **ON**, .1 sec **OFF**, .1 sec **ON**, .1 sec **OFF**, .1 sec **ON**, .1 sec **OFF**, .1 sec **ON**, .3 sec **OFF**

A LED Error Indication:

Waiting for application firmware to be downloaded: .1 sec **ON**, .1 sec **OFF**.

B LED: SIO Communication Port Status:

Indicates communication activity on the SIO communication port

CT: Cabinet Tamper

BA: Power Fault

LED 1 through 16: Illuminates when output relay OUT 1 (K1), OUT 2 (K2) is energized and so on.

8. Specifications:

The MR16out is for use in low voltage, class 2 circuits only.

Primary power:	12 to 24Vdc \pm 10%, 1100mA maximum 12Vdc @ 850mA nominal 24Vdc @ 450mA nominal
Relay contacts:	16 Form-C, 5A @ 30Vdc, resistive
Inputs:	2 unsupervised, dedicated for cabinet tamper and UPS fault monitoring
Communication:	RS-485, 2-wire. 9600, 19200, 38400, or 115200 bps
Cable requirements:	
Power:	1 twisted pair, 18 AWG
RS-485:	24AWG, 120 ohm impedance, twisted pair with shield, 4,000' (1,200m) maximum
Inputs:	1 twisted pair, 30 ohms maximum
Outputs:	As required for the load
Mechanical:	
Dimension:	6" (152mm)W x 8" (203mm)L x 1" (25.4mm)H
Weight:	14 oz. (400 gm) nominal
Environmental:	
Temperature:	-55°C to +85°C, storage 0°C, to +70°C, operating
Humidity:	0% to 95% RHNC

Warranty:

Mercury Security Corporation warrants the product is free from defects in material and workmanship under normal use and service with proper maintenance for one year from the date of factory shipment. Mercury Security Corporation assumes no responsibility for products damaged by improper handling or installation. This warranty is limited to the repair or replacement of the defective unit.

There are no expressed warranties other than set forth herein. Mercury Security Corporation does not make, nor intends, nor does it authorize any agent or representative to make any other warranties, or implied warranties, and expressly excludes and disclaims all implied warranties of merchantability or fitness for a particular purpose.

Returned units are repaired or replaced from a stock of reconditioned units. Returns must be accompanied by a return authorization number (RMA) obtained from customer service, and prepaid postage and insurance.

Liability:

The Interface should only be used to control exits from areas where an alternative method for exit is available. This product is not intended for, nor is rated for operation in life-critical control applications. Mercury Security Corporation is not liable under any circumstances for loss or damage caused by or partially caused by the misapplication or malfunction of the product. Mercury Security Corporation's liability does not extend beyond the purchase price of the product.