



LGMG North America Inc.

Service Manual

**SS1230E/SS1432E/SS1932E/AS1930E/
AS1932E/AS2632E/AS2646E/AS3246E/
AS4046E/AS4650E/AS1930/AS1932/
AS2632/AS2646/AS3246/AS4046/AS4650**

**Mobile Elevating Work Platform
ANSI**



WARNING

Before operation and maintenance, the drivers and service personnel shall always read and thoroughly understand all information in this manual. Failure to do so may result in, fatal accidents or personal injury.

This manual must be kept with this machine at all times.

This page left blank intentionally

Foreword

Thank you for choosing to use this Mobile Elevating Work Platform from LGMG North America. This machine is designed according to A92.20-2018. The information specified in this manual is intended for the safe and proper operation of this machine for its' intended purpose.

For maximum performance and utilization of this machine, thoroughly read and understand all the information in this manual before starting, operating, or performing maintenance on this machine.

Due to continuous product improvements, LGMG North America reserves the right to make specification changes without any prior notifications. For any updated information, contact LGMG North America.

Ensure all preventive maintenance to the machine is performed according to the interval specified in the maintenance schedule.

Keep this manual with this machine for reference at all times. When the ownership of this machine is transferred, this manual shall be transferred with this machine. This manual must be replaced immediately if it is lost, damaged, or becomes illegible.

This manual is copyrighted material. The reproduction or copy of this manual is not allowed without the written approval of LGMG North America.

The information, technical specifications and drawings in this manual are the latest available when this manual is issued. Due to continuous improvement, LGMG North America reserves the right to change the technical specifications and machine design without notice. If any specifications and information in the manual are not consistent with your machine, please contact the service department of LGMG North America.



Only personnel who have been properly trained and qualified to operate or maintain this machine can operate, repair and maintain this machine.

Improper operation, maintenance, and repair are dangerous and can cause personal injury and death.

Before any operation or maintenance, the operator shall thoroughly read this manual. Do not operate, perform any maintenance or make any repairs on this machine before reading and understanding this manual.

The user shall load the platform strictly according to the load rating of the platform. Do not overload the platform or make any modifications to the platform without permission from LGMG North America.

The operation regulations and preventions in this manual are only applicable for the specified use of this machine.

Safety Precautions

The operator of this machine shall understand and follow the existing safety regulations of state and local governments. If these are unavailable, the safety instructions in this manual shall be followed.

To help prevent accidents, read and understand all warnings and precautions in this manual before operation or performing maintenance.

The safety measures are specified in Chapter 1 Safety.

It is impossible to foresee every possible hazard and the safety instructions in this manual may not cover all safety prevention measures. Always ensure the safety of all personnel and protect the machine against any damage. If unable to confirm the safety of some operations, contact LGMG North America.

The operation & maintenance prevention measures listed in this manual are only applicable to the specified uses of this machine. LGMG North America assumes no responsibility if this machine is used beyond the range of this manual. The user and the operator shall be responsible for the safety of such operations.

Do not perform any operation forbidden in this manual in any situation.

The following signal words are applicable for identifying the level of safety information in this manual.

 **Danger:**

An imminent situation, that if not avoided, will result in severe injuries or death. This is also applicable to situations that will cause serious machine damage, if not avoided.

 **Warning:**

A potentially dangerous situation, that if not avoided, may result in severe injuries or death. This is also applicable to situations that may cause serious machine damage, if not avoided.

 **Notice:**

A situation, that if not avoided, may result in minor or intermediate injury. This is also applicable to situations that may cause machine damage or shorten machine service life.

Contents

Chapter 1 Maintenance	1
1.1 Battery Inspection.....	1
1.2 Battery Maintenance Schedule	1
1.3 Hydraulic Oil Level.....	1
1.4 Pre-Delivery Preparation Report.....	2
1.5 Maintenance Schedule	2
1.6 Maintenance and Inspection Report	2
1.6.1 General Information	2
1.6.2 Description.....	2
1.7 Pre-Delivery Preparation Report.....	3
1.7.1 General Information	3
1.7.2 Description.....	3
1.8 Checklist A	3
1.8.1 A-1 Inspection of Manual and Decals.....	3
1.8.2 A-2 Pre-Operation Inspection.....	4
1.8.3 A-3 Function Test.....	4
1.8.4 A-4 30-Day Maintenance	4
1.9 Checklist B	4
1.9.1 B-1 Battery Inspection.....	4
1.9.2 B-2 Wiring Inspection	6
1.9.3 B-3 Inspection of Tire and Wheel	7
1.9.4 B-4 Inspection of Emergency Stop Switches.....	8
1.9.5 B-5 Testing the Key Switch	8
1.9.6 B-6 Testing the Horn.....	9
1.9.7 B-7 Testing the Driving and Braking Functions.....	9
1.9.8 B-8 Testing Drive Speed from the Platform Stowed Position.....	9

1.9.9 B-9 Testing Drive Speed from the Platform Elevated Position.....	10
1.9.10 B-10 Low Speed Drive Test	11
1.9.11 B-11 Visual Inspection of the Hydraulic Oil.....	11
1.9.12 B-12 Hydraulic Oil Tank Ventilation Inspection.....	12
1.9.13 B-13 Inspection of the Chassis Tray Locking Mechanism.....	12
1.9.14 B-14 Inspection of the Down Limit and Pothole Limit Switches.....	12
1.9.15 B-15 Inspection of the Upper Limit Switch.....	16
1.9.16 B-16 Inspection of steering knuckle.....	17
1.9.17 B-17 Check and Replacement of Electric Brush.....	18
1.10 Checklist C	20
1.10.1 C-1 Testing the Platform Overload System (If Equipped)	20
1.10.2 C-2 Replacement of the Hydraulic Tank Breather Cap.....	22
1.11 Checklist D	22
1.11.1 D-1 Inspection of the Scissor Arm Slide Blocks.....	22
1.11.2 D-2 Replacement of Oil Return Filter in the Hydraulic Tank	23
1.12 Checklist E	24
1.12.1 E-1 Test and replacement of Hydraulic Oil	24
Chapter 2 Maintenance Schedules	27
2.1 Battery Maintenance Schedule	27
2.2 Maintenance Schedule	28
2.2.1 Routine Inspection and Maintenance Intervals.....	28
2.2.2 Hydraulic Oil Selection and Specifications	31
Chapter 3 Error Codes and Troubleshooting.....	33
3.1 Error Codes.....	33
3.2 Troubleshooting Guide	35
Chapter 4 Hydraulic Drive Control System.....	39
4.1 Basic Operation.....	39

4.2 Main Power and Safety.....	39
4.3 Lifting and Lifting Safety	39
4.4 Driving and Driving Safety	40
4.5 Steering and Steering Safety.....	40
4.6 Miscellaneous Operations	40
4.7 Low Power Operation	40
4.8 Platform Control Unit (PCU) and Electronic Control Unit (ECU).....	42
4.9 User Adjustments and Lift Set Up.....	43
4.10 Battery Drain Shut-Off and Alarm State	45
4.11 Change Shut-Off Delay.....	46
4.12 Change Alarm Delay	46
4.13 Speed Adjust State.....	47
4.14 Drive High Speed (with Platform Stowed).....	47
4.15 Drive Low Speed	48
4.16 Drive Elevated Speed.....	48
4.17 Lift Speed	49
4.18 Steering Speed.....	49
4.19 Fault State	50
4.20 Fault History State	53
4.21 Normal Operating State	53
4.21.1 Driving Forward or Backward with the Platform Stowed	53
4.21.2 Raising or Lowering the Platform	53
4.21.3 Software Revision and Machine Option Displayed	54
4.22 Operating the Lift with the Platform Elevated	54
4.23 Displays on the PCU and ECU in normal operation	55
4.24 Battery Charge State	56
Chapter 5 Schematics	57



This page left blank intentionally

Chapter 1 Maintenance



Observe and Obey:

Only qualified technicians shall perform maintenance on components specified in this manual.

Regular maintenance and inspection shall only be made by trained maintenance technicians as per the requirements of LGMG North America.

1.1 Battery Inspection

Maintaining the battery in good condition is essential to performance and safe operation of this machine. Improper electrolyte level or damaged cables or wiring may cause component damage or a hazardous condition.



This section does not apply to sealed batteries. If your machine utilizes sealed batteries, disregard this section.



Electrocution Hazard:

Take measures to prevent electric shock due to touching the battery terminals or connectors. When working on the batteries or electrical circuits, remove all jewelry and metallic objects.



Battery electrolyte is corrosive. Do not expose hands or body parts to overflowed or spilled electrolyte, due to risk of personal injury. Neutralize the overflowed or spilled electrolyte with the sodium bicarbonate solution.

1.2 Battery Maintenance Schedule

Refer to the Maintenance Schedule for the maintenance plan of the batteries.

1.3 Hydraulic Oil Level

Maintaining proper hydraulic oil level is essential to efficient and reliable machine operation. If the proper hydraulic oil level is not maintained, hydraulic components may be damaged and/or cease functioning. Changes in hydraulic oil level can be determined by the inspector when performing the daily inspection. Changes in the hydraulic oil level may indicate a leak or other problem in the hydraulic system.



To fill the hydraulic oil, it is a requirement to use the proper hydraulic oil in accordance with the work site environment and ambient temperature with reference to the following:

- L-HM 46 antiwear hydraulic oil: minimum air temperature > 15.8°F (-9°C);
- L-HV 46 low temperature hydraulic oil: (-33°C)-27.4°F < minimum air temperature ≤ 15.8°F (-9°C);
- L-HS 46 Ultralow temperature hydraulic oil: (-39°C)-38.2°F < minimum air temperature ≤ -27.4°F (-33°C)
- 10# aviation hydraulic oil: minimum air temperature ≤ -38.2°F (-39°C);

1.4 Pre-Delivery Preparation Report

- 1) The pre-delivery preparation report shall cover the inspection items of each type.
- 2) The pre-delivery preparation report shall be prepared for each inspection. Such report shall be saved as required after being completed.

1.5 Maintenance Schedule

The daily, quarterly, semi-annual, annual and once-per-two-year maintenance must be done as per the schedule. The product maintenance program and the pre-delivery preparation report can be divided into A, B, C, D, E and F sub items. The steps of each inspection are as shown in the table below.

Table 1 Inspection Checklists

Inspection Cycle	Inspection item
Every day or every 2 hours	A
Every month or every 25 hours	A+B
Every season or every 50 hours	A+B+C
Each half a year or every 100 hours	A+B+C+D
Each year or every 200 hours	A+B+C+D+E
Every two years or every 400 hours	A+B+C+D+E+F

Table 2 Inspection Report

Legend description			
Y=Yes, completed			
N=No, un-completed			
R=Repaired			
Evaluation			
Pre-delivery preparation	Y	N	R
Operation inspection completed			
Maintenance item completed			
Function test completed			
Model			
Serial number			
Date			
Owner			
Inspector (printed)			
Signature of inspector			
Title of inspector			
Inspection company			

1.6 Maintenance and Inspection Report

1.6.1 General Information

- 1) The maintenance and inspection report shall cover each type of inspection item.
- 2) The maintenance and inspection report shall be prepared for each inspection.
- 3) Keep the report for at least 4 years after inspection or as specified by local government laws and regulations.

1.6.2 Description

- One report is applicable for each inspection.

- Choose the appropriate checklist according to the items to be checked.
- Place a check mark on the corresponding box on the inspection form after each item is inspected.
- Learn how to make step-by-step inspections.
- If the item's inspection results in an "N" result, tag out the machine's controls until it is repaired and checked again. Mark an "R" in the appropriate box on the inspection form after the repair has been made;
 - ① Before delivery.
 - ② Completion of operation check.
 - ③ Project maintenance completion.
 - ④ Functional test completion.

1.7 Pre-Delivery Preparation Report

1.7.1 General Information

- 1) The distributor shall be responsible for Pre-Delivery Preparation.
- 2) Priority shall be given to pre-delivery preparation for each individual product delivery. The purpose of this inspection is to find any problems with the equipment prior to use.
- 3) Using damaged or modified equipment is strictly forbidden. If any damage or inconformity is found during equipment delivery, tag out the machine controls at once and do not use the machine until it is repaired.
- 4) The machine must be repaired by an

authorized technician per the specification of the manufacturer and the requirements of this manual.

1.7.2 Description

- 1) Thoroughly read, understand, and adhere to the instructions in the Operation Manual with this machine.
- 2) The pre-delivery preparation composed of the operation check, maintenance item and function test.
- 3) Record the result with a table. Complete each completed item in corresponding table according to the description in the operation manual. Refer to Table 2 – Inspection Report.
- 4) If any inspection results in an "N" (No, Uncompleted) rating, stop using the machine immediately. Repair and check the equipment again. Mark the item "R" (Repaired) after the item has passed inspection.

1.8 Checklist A

1.8.1 A-1 Inspection of Manual and Decals

Each machine is supplied with an Operation Manual in the manual storage box on the platform. An illegible, damaged, or missing manual must be replaced immediately.

Keep all decals and signs clean and in good condition. The decals can inform the operator of potential operational hazards of the machine. The decals also provide operation and maintenance information to the operator.

- 1) Ensure the operation and maintenance manual is kept in the manual box in the platform.
- 2) Check the legibility or any damaged or missing pages. Make sure the model of the manual is matched with the model of the machine.
- 3) If the manual is missing, not matched with the model of the machine, or is illegible or damaged, cease using the machine until the manual is replaced.
- 4) Refer to the decal diagram and check if each decal is illegible or damaged. All labels should be legible and undamaged. If any decals are missing, illegible, or damaged, stop using the machine until any missing or damaged decals have been replaced.
- 5) Make sure the Operation Manual is always returned to the manual storage box in the platform after each use.
- 6) Contact LGMG North America for manual or decal replacements.

1.8.2 A-2 Pre-Operation Inspection

The pre-operation inspection is essential to ensure the proper operation of the machine. The pre-operation inspection is made in the form of visual inspection before machine operation. This inspection is used for discovering significant problems before the function test and for determining if routine maintenance is necessary. For all inspection procedures, please refer to "Pre-Operation Inspection" in this manual.

1.8.3 A-3 Function Test

The function test is essential for the proper operation of machine. The function test is used to discover any functional defects the machine may have prior to operation. A machine with any operating defects cannot be put into service. If any functional defects are found, please tag out the machine controls immediately and discontinue operation.

For all inspection procedures, please refer to Function Test in this manual.

1.8.4 A-4 30-Day Maintenance

The 30-day maintenance check is made after the first 30 days or the first 25 hours of machine operation. After this step, continue to check the maintenance items on the check list.

Maintenance items on the list are:

- 1) B-3 Tire and Wheel.

1.9 Checklist B

1.9.1 B-1 Battery Inspection

This check item shall be made once every 25 hours of operation or every month, whichever interval is shorter.

Keeping the batteries in good condition is essential to machine performance and proper operation. Incorrect electrolyte level or damaged cables or connectors may cause the machine damage and hazardous working conditions.



Warning
Electrocution Hazard

Coming in contact with live electricity during operation may cause severe personal injury or death. Take off all jewelry and metallic objects while operating the machine.



Personal Injury Hazard

Battery electrolyte is corrosive. Do not expose hands or any body parts to electrolyte to prevent injury. Neutralize any overflowed electrolyte with a sodium bicarbonate solution.

- 1) When working on or around the batteries, wear protective clothing and safety goggles
- 2) Release the battery tray lock on the chassis side and rotate the chassis battery tray outward.
- 3) Ensure the battery cables, connectors, and battery terminals are firmly attached.
- 4) Protect the battery cable connector against corrosion. Add a wiring end protector and coat the battery terminals with an anti-corrosion product to protect the battery connector cables and terminals against corrosion.
- 5) Fully charge the batteries and maintain the charge for at least 24 hours.
- 6) Open the battery cell cover(s), check the specific weight with a specific gravity hydrometer and record the value.
- 7) Check ambient temperature and adjust the specific liquid gravity of each battery according to the instructions in the following steps.
- 8) Increase the specific liquid gravity by 0.004 per 41°F (5°C), if the temperature is higher than 80.6°F (27°C).
- 9) Decrease the specific liquid gravity by 0.004 per 41°F (5°C,) if the temperature is lower than 80.6°F (27°C).
- 10) Result: the specific liquid gravity of each battery is greater than 1.277 after the adjustment. Fully charge the battery and turn to Step 12.
- 11) Result: If the specific liquid gravity of each battery is lower than 1.250, turn to Step 8.
- 12) Charge the battery in a balanced way or fully charge the battery and maintain the charge for at least 6 hours (preferably 24 hours).
- 13) Ensure the battery cells in each battery pack are correctly connected.
- 14) Check for excessive abrasion or damage to the battery charger plug and wire insulation. If the plug or wire are damaged, replace them immediately.



Steps 6 thru 12 do not apply to sealed or maintenance free batteries.

- 15) Connect the battery charger to a 100-260V, 50/60HZ AC power supply.

Result: the charger is running and charging the battery.

Result: the charger alarm sounds and the indicator flashes. Please check and correct the connection of fuse and charger.

Ensure the charger is operating properly and charge the battery.



For best results, ensure the total length of the charger cord is less than 50 ft. (15m).

For more information on charger operation, please contact the after-sales service department of LGMG North America.

1.9.2 B-2 Wiring Inspection

This check item shall be made once every 25 hours of operation or every month, whichever interval is shorter.

Keeping the wiring in good condition is essential to proper operation and machine performance. If any wiring is found to be burnt, damaged, corroded or bent is found, it must be repaired or replaced immediately. If the machine is operated with damaged wiring, the machine may be damaged.



Electrocution/Explosion Danger

Contact with electrical components may cause serious injury or death. Take off all jewelry and metallic objects while

performing inspection or maintenance of electrical components.

- 1) Check to see if the ground wire below the chassis is missing or damaged.
- 2) Check if there is any burnt, damaged, corroded, bent or loose wiring in the areas below:
 - ① Inside the ground controller box
 - ② Wiring of hydraulic control valves
 - ③ Wiring in the battery area of the battery tray
 - ④ Inside the platform controller box
- 3) Position the key switch to the platform controller and pull out the emergency stop switches on the ground and platform controllers.
- 4) Elevate the platform to the height given in the following table:

Table 3 - Safety Prop Deployment Height

Model	Height
SS1230E	7.9ft (2.4m)
SS1432E	
AS1930	
AS1930E	
AS1932	
AS1932E	9.09ft (2.77m)
SS1932E	
AS2632	10.5ft (3.2m)
AS2632E	
AS2646	10.5ft (3.2m)
AS2646E	
AS3246	
AS3246E	
AS4046	13.1ft (4m)
AS4046E	
AS4650	

AS4650E

- 5) Lift the safety arm, move it to the center of the scissor cross tube and rotate it upward until it is vertical.
- 6) Slowly lower the platform until the safety arm completely contacts the scissor cross tube.



Crushing Hazard

Be sure to put your hand on correct position of the safety arm when lowering the platform.

- 7) Check for any burnt, damaged, corroded, bent, or loose wiring in chassis and scissor area.
- 8) Check if there is any burnt, damaged, corroded, bent, or loose wiring in the areas below:
 - Wiring running through the scissor arms
 - ECU to the platform
 - Harness connector on the platform
- 9) Check the dielectric grease on the positions below:
 - Harness connector connected between ECU and platform controller
 - All harness connectors connected to the level sensor
- 10) Raise the platform and return the safety arm to the stowed position.
- 11) Lower the platform to the stowed position and

shut down the machine.

1.9.3 B-3 Inspection of Tire and Wheel

This check item shall be made once every 25 hours of operation or every month, whichever interval is shorter.

Keeping the tire and wheel in good conditions is essential to proper operation and good performance. The failure of tire and wheel could potentially cause the machine to tip over causing damage to the machine and personal injury. If defective tires and wheels are found, they must be replaced immediately.

- 1) Check if the tread and sides of the tire show any damage, cracks, holes or other abnormal wear.
- 2) Check if the rim is damaged, bent, or cracked.
- 3) Remove the cotter pin and check the wheel nut torque on each wheel lug. Torque should be 410-540N on hydraulic drive machines, and 90N on electric drive machines.



A new cotter pin must be used when reinstalling the tire and wheel.

- 4) Install and secure a new cotter pin.
- 5) Lubricate the steering spindles.

1.9.4 B-4 Inspection of Emergency Stop Switches



The emergency stop button of the ground controller can stop all operations of the machine, even if the key switch is switched to the platform controller.

This check item shall be made once every 25 hours of operation or every month, whichever interval is shorter.

- 1) The normal emergency stop function is essential for the proper operation of the machine. If it does not cut off the power supply and stop all functions of the machine a hazardous working condition can be the result.
- 2) Besides the emergency stop button on the platform, the selection and operation of the ground controller shall be a priority to those of the platform controller.
- 3) Turn the key switch to the ground controller position and pull out the emergency stop switch on both the ground and platform controllers.
- 4) Press the emergency stop button on the ground controller to the OFF position. Result: No action is enabled by the machine.
- 5) Press the emergency stop button on the platform controller to the OFF position. Result: No action is enabled by the machine.

1.9.5 B-5 Testing the Key Switch

This check item shall be made once every 25 hours of operation or every month, whichever interval is shorter.

- 1) The correct action and response of the key switch is essential to the proper operation of the machine. The machine can be operated via the ground controller or the platform controller. The key switch is used for switching between the two controllers. A failed switch may cause the dangerous or improper operation.



No personnel shall occupy the platform while the following steps are carried out from the ground using the platform controller.

- 2) Pull out the emergency stop switches from the ground and platform controllers.
- 3) Turn the key switch to the platform controller position.
- 4) Check the lifting and lowering functions from the ground controller. Result: No action is enabled by the machine.
- 5) Turn the key switch to the ground controller position.
- 6) Check the lifting and lowering functions from the platform controller. Result: No action is enabled by the machine.
- 7) Turn the key switch to the OFF position. Result: No action is enabled by the machine.

1.9.6 B-6 Testing the Horn

These check items shall be made once every 25 hours of operation or every month, whichever interval is shorter.

- 1) The horn is used for giving a warning to personnel on the ground by the operator in the platform. If the horn is not functioning properly, the operator would be unable to alert ground personnel of any hazards or unsafe conditions.
- 2) Switch the key switch to the platform controller position and pull out the emergency stop switch on both the ground and platform controllers.
- 3) Press the horn button on the platform controller. Result: The horn should sound.

1.9.7 B-7 Testing the Driving and Braking Functions

These check items shall be made once every 25 hours of operation or every month, whichever interval is shorter.



The brake must be capable of stopping and holding the machine within the allowable gradeability range of the machine. If it does not, replace the brake and repeat the test process the beginning.

- 4) Normal braking and brake release function is essential to proper operation. The brake must be stable and free of delay, vibration, and

abnormal sounds.

- 5) Ensure the machine is stowed and the extending platform is completely retracted. Complete the braking function inspection on solid and level ground without any barriers.
- 6) Make a reference test line on the ground.
- 7) Turn the key switch to the platform controller position and pull out the emergency stop switches on both the ground and platform controllers.
- 8) Press the drive function selector button.
- 9) Select one point (such as the contact patch of a tire) from the machine as the visual inspection reference of the test line.
- 10) Drive the machine at the maximum speed and release the handle at the moment when the reference point passes the ground test line.
- 11) Measure the distance between the reference point and the test line. Result: The machine has stopped within the specified braking distance. No action is required. Result: The machine has not stopped within the specified braking distance. Repair or replace the brake and repeat the testing process beginning at Step 1.

1.9.8 B-8 Testing Drive Speed from the Platform Stowed Position

This check item shall be made once every 25 hours of operation or every month, whichever interval is shorter.

- 1) The normal driving function is essential for

proper operation of the machine. The operator should experience a rapid and stable response. No delay, vibration and abnormal sound should occur during the normal operation and driving function.

- 2) Complete the driving test on firm and level ground without any barriers.
- 3) Draw two lines, spaced by 32.8ft (10m) on the ground, as the starting line and the finishing line.
- 4) Turn the key switch to the platform controller position and pull out the emergency stop switches from both the ground and platform controllers.
- 5) Lower the platform to the stowed position.
- 6) Press the drive function selector button.
- 7) Select one point on the machine as the visual inspection reference point for both the starting line and the finishing line.
- 8) Drive the machine at maximum speed and start to count when the reference point passes the starting line.
- 9) Keep driving at the full speed and record the time when the reference point passes the finishing line. Refer to the specification.

1.9.9 B-9 Testing Drive Speed from the Platform Elevated Position

This check item shall be made once every 25 hours of operation or every month, whichever interval is shorter.

- 1) The normal driving function is essential for proper operation of the machine. The

operator should experience a rapid and stable response. No delay, vibration and abnormal sound should occur during the normal operation and driving function.

- 2) Complete the driving test on firm and level ground without any barriers.
- 3) Draw two lines, spaced by 32.8ft (10m) on the ground, as the starting line and the finishing line.
- 4) Turn the key switch to the platform controller position and pull out the emergency stop switches from both the ground and platform controls.
- 5) Press the lifting function selector button.
- 6) Press the enable key
- 7) Lift the platform for a given height above the ground as shown in the following table.

Table 4 - Lifting Height for Drive Test

Model	Height
SS1230E	7.5ft (2.3m)
SS1432E	
AS1930	
AS1930E	
AS1932	
SS1932E	
AS2632	
AS2632E	
AS3246	
AS3246E	
AS4046	
AS4046E	
AS1932E	
AS2646	8.2ft (2.5m)

AS2646E	
AS4650	8.53ft (2.6m)
AS4650E	

- 8) Press the drive function selector button.
- 9) Select one point (such as the contact patch of a tire) on the machine as the visual inspection reference for the starting line and the finishing line.
- 10) Drive the machine at maximum speed and start to count when the reference point passes the starting line.
- 11) Keep driving at the full speed and record the time when the reference point passes the finishing line. Refer to the specification.

1.9.10 B-10 Low Speed Drive Test

This check shall be made once per 25h or per month, whichever is shorter.

1. Normal drive function is essential to the proper operation and usage of the machine. With the drive function, a rapid and stable response shall be given to the operator. No delay, vibration and abnormal sound shall occur during normal operation and drive process.
2. Complete the driving test on a solid and level ground without any barriers.
3. Draw two lines, 32.8ft (10m) apart, as the starting line and the ending line on the ground.
4. Switch the key switch to the platform controller position and pull out the red emergency stop buttons from the ground and

platform controllers.

5. Lower the platform to the stowed position.
6. Press the drive speed selector button.
7. Select one point (such as the contact patch of a tire) from the machine as the visual inspection reference for the starting line and the ending line.
8. Drive the machine at maximum speed and start to count when the reference point passes the starting line.
9. Keep driving at the full speed and record the time when the reference point passes the finishing line. The driving time shall not be less than 22.5seconds.

1.9.11 B-11 Visual Inspection of the Hydraulic Oil

This check item shall be made once every 25 hours of operation or every month, whichever interval is shorter.

Collect a sample of hydraulic oil and place in a clear container. Visually inspect the hydraulic oil for the following:

- 1) Color: oil should be a clear, light-honey colored.
- 2) Appearance: oil should be clear and not cloudy or visibly distorts the view through the sight glass or container.
- 3) Contains no particles, foreign objects, or other contamination.
- 4) The hydraulic oil can be inspected by smell (can smell "hot" but not "burnt") or rubbing between fingers (should feel viscous and free of any rough feel due to particles) If the hydraulic oil passes all of the above inspections, continue the scheduled

maintenance intervals. If the hydraulic oil fails any of the above inspections, the hydraulic oil must be tested by an oil distributor or replaced.

Note: If the hydraulic oil has not been replaced for two years, the oil must be tested every quarter by an oil distributor until the oil fails the test and is replaced. After the oil has been replaced, continue the scheduled quarterly maintenance inspection.

Note: When replacing the hydraulic oil, it is recommended that all hydraulic filters be replaced at the same time.

For test and replacement of hydraulic oil, please refer to E-1.

1.9.12 B-12 Hydraulic Oil Tank Ventilation Inspection

This check item shall be made once every 25 hours of operation or every month, whichever interval is shorter.

- 1) The well-ventilated hydraulic oil tank cover is essential to maintain components in good condition and service life of the hydraulic oil. A dirty or blocked exhaust cover may degrade machine performance. Even more frequent inspection is required when operating in a harsh or hostile work environment.
- 2) Remove the exhaust cover from the hydraulic oil tank cover.
- 3) Check ventilation. Result: The air can pass through the exhaust cover. Result: If the air is unable to pass through the exhaust cover, clean or replace the exhaust cover

immediately. Continue with Step 4



Notice

Air shall freely pass through the oil tank cover when checking the ventilation.

- 4) Carefully wash the oil tank exhaust cover with mild solvent and dry it with low-pressure compressed air. Check for proper ventilation again.
- 5) Install the exhaust cover onto the hydraulic oil tank

1.9.13 B-13 Inspection of the Chassis Tray Locking Mechanism

This check item shall be made once every 25 hours of operation or every month, whichever interval is shorter.

- 1) The condition of chassis tray locking mechanism is essential to equipment performance and service life. If the tray unexpectedly opened, a hazardous condition can occur. Check each chassis tray locking mechanism for damage or loose parts.

1.9.14 B-14 Inspection of the Down Limit and Pothole Limit Switches

This check item shall be made once every 25 hours of operation or every month, whichever interval is shorter.

- 1) Good condition of the limit switches is essential for proper machine operation and performance. The operation of the machine with a defective limit switch will degrade the

machine performance and cause a potential unsafe working environment.

- 2) Perform this inspection on solid and level ground without any barriers.

Down Limit Switch

- 1) Remove the platform controller to operate from the ground.
- 2) Lift the platform a predetermined height above the ground. The lifting height of every model is given in the following table.

Table 5 - Safety Prop Deployment Height

Model	Height
SS1230E	7.9ft (2.4m)
SS1432E	
AS1932	
AS1932E	7.9ft (2.4m)
AS1930	
AS1930E	
SS1932E	9.09ft (2.77m)
AS2632	10.5ft (3.2m)
AS2632E	
AS2646	
AS2646E	
AS3246	
AS3246E	
AS4046	13.1ft (4m)
AS4046E	
AS4650	
AS4650E	

- 3) Lift the safety arm, move it to the center of the scissor cross tube and rotate it upward until it is vertical.
- 4) Carefully lower the platform height until the

safety arm completely contacts the cross tube.



Be sure to handle the safety prop properly when lowering the platform.

- 5) Turn the key switch to the OFF position.
- 6) Release the platform controller and do the test.
- 7) Open the down limit switch base cover and unplug the connector to the down limit switch.
- 8) Turn the key switch to the platform controller position.
- 9) Slightly raise the platform and return the safety prop to the stowed position.
- 10) From the ground, press the lifting function selector button on the platform controller and lower the platform until it is stowed. Result: the diagnosis screen displays Code 18, the alarm sounds, and the lifting function response is normal. The function of machine is normal. Result: the diagnosis screen does not display Code 18, no alarm sounds, and the lifting function gives no response. In this instance, the limit switch must be replaced
- 11) Press the drive function selector button and try to run the machine. Result: the diagnosis screen displays Code 18, the alarm sounds, but the turning function and the driving function are disabled. The function of machine is normal. Result: the diagnosis screen does not display the code 18, the

alarm sounds, and the turning and driving functions are enabled. In this instance, the limit switch shall be replaced.

- 12) Press the lifting function selector button to raise the platform by approximately 1ft (0.3m).
Result: the diagnosis screen displays Code 18, the alarm sounds and the lifting function is enabled. The function of machine is normal.
Result: the diagnosis screen dose not display Code 18 and the alarm sounds. In this instance, the limit switch must be replaced.
- 13) Raise the platform until the pothole guards are deployed. Result: the diagnosis screen does not display Code 18 and the alarm does not sound. The function of machine is normal.
Result: the diagnosis screen displays Code 18 and the alarm sounds. In this instance, the limit switch must be replaced.
- 14) Lift the platform a predetermined height above the ground. The lifting height of every model is given in the following table.

Table 6 - Safety Prop Deployment Height

Model	Height
SS1230E	7.9ft (2.4m)
SS1432E	
AS1930	
AS1930E	
AS1932	
AS1932E	
SS1932E	9.09ft (2.77m)
AS2632	10.5ft (3.2m)
AS2632E	
AS2646	
AS2646E	

AS3246	13.1ft (4m)
AS3246E	
AS4046	
AS4046E	
AS4650	
AS4650E	

- 15) Lift the safety arm move it to the center of the scissor cross tube and rotate it upward until it is vertical.
- 16) Carefully lower the platform height until the safety arm completely contacts the cross tube.



Crushing Hazard

- 17) Turn the key switch to the OFF position.
- 18) Disconnect the platform controller from the chassis main harness.
- 19) Restore the connection between the platform controller connector and the chassis main harness.
- 20) Connect the platform control connector.
- 21) Properly reconnect the down limit switch connector.
- 22) Reinstall the down limit switch box.
- 23) Turn the key switch to the platform controller position.
- 24) Slightly raise the platform and return the safety prop to the stowed position.
- 25) Lower the platform to the stowed position.

Inclination Switch

- 1) Move the machine to the maximum allowable inclination angle of the level sensor. For the maximum allowable inclination angle, refer to the nameplate on the machine.
- 2) Press the lift button to lift the machine for a predetermined height on a slope. The lifting height of every model is given in the following table.

Table 7 - Activation Height for Tilt Alarm

Model	Height
AS1930	5.6ft (1.7m)
AS1930E	
AS1932	
AS1932E	
AS2632	
SS1230E	6.9ft (2.1m)
SS1432E	
SS1932E	
AS2632E	
AS3246	
AS3246E	
AS4046E	6.9ft (2.1m)
AS4046	
AS4650	8.3ft (2.52m)
AS4650E	
AS2646	8.5ft (2.6m)
AS2646E	

Result: the diagnosis screen displays the code LL, no alarm sounds, no lift function after pothole guards are deployed completely, and machine function is normal

Result: the diagnosis screen does not display the code LL, the alarm sounds, and the lift function works after the pothole guards are deployed

- completely. In this instance, please check or replace the inclination switch.
- 3) Press the drive function selector button and try to drive the machine on a slope. Result: the diagnosis screen displays Code LL, the alarm sounds, and the turning function and the driving function are disabled. The function of machine is normal. Result: the diagnosis screen dose not display the code LL, no alarm sounds, and the driving and turning function of machine are normal. Check or replace the inclination switch.

Pothole Limit Switch

- 1) Lower the platform to the stowed position and drive the machine to firm and level ground.
- 2) Place a wood block about 2in (5cm) high under the right pothole guard
- 3) Press the lifting button to lift the machine to a predetermined height. The lifting height of every model is given in the following table.

Model	Height
AS1930	5ft (1.5m)
AS1930E	
AS1932	
AS1932E	
SS1932E	
AS2632	
SS1230E	6.9ft (2.1m)
SS1432E	
AS2632E	
AS3246	
AS3246E	
AS4046	
AS4046E	8.3ft (2.52m)
AS4650	

AS4650E	
AS2646	8.53ft (2.6m)
AS2646E	

Result: the pothole guard contacts the block and fails to be completely stretched. The diagnosis screen displays Code 18, alarm sounds and the machine will lift to a certain height. Machine function is normal. Result: the pothole guard contacts the block and fails to be completely deployed. The diagnosis screen does not display Code 18, no alarm sounds, and the platform can still be elevated. In this instance, the pothole guard limit switch must be adjusted or replaced.

- 4) Press the drive function selector button and try to drive and steer the machine. Result: the diagnosis screen displays Code 18, the alarm sounds, and the steering and drive functions are normal. The function of machine is normal. Result: the diagnosis screen does not display Code 18, no alarm sounds and drive and steering functions of machine are disabled. In this instance, the pothole limit switch must be adjusted or replaced.
- 5) Lower the platform until it is stowed and remove the wood block under the right pothole guard.
- 6) Repeat Step 3-5 for the left pothole guard
- 7) Lower the platform until it is stowed and then remove the wood block under the left pothole guard.
- 8) Turn off the machine.

1.9.15 B-15 Inspection of the Upper Limit Switch

This check item shall be made once every 25 hours of operation or every month, whichever interval is shorter.

- 1) Good condition of the limit switches is essential for proper machine operation and performance. The operation of the machine with a defective limit switch will degrade the machine performance and cause a potential unsafe working environment.
- 2) Perform this inspection on solid and level ground without any barriers.
- 3) Turn the key switch to the ground controller position. Elevate the platform for a predetermined height above the ground as shown in the following table.

Table 8 - Safety Prop Deployment Height

Model	Height
SS1230E	7.9ft (2.4m)
SS1432E	
AS1930	
AS1930E	
AS1932	
AS1932E	9.09ft (2.77m)
SS1932E	10.5ft (3.2m)
AS2632	
AS2632E	
AS2646	
AS2646E	
AS3246	
AS3246E	
AS4046	13.1ft (4m)

AS4046E	
AS4650	
AS4650E	

- 4) Lift the safety arm, move it to the center of the scissor cross tube and rotate it upward until it is vertical.
- 5) Carefully lower the platform until the safety prop completely contacts the cross tube.



Warning

Crushing Hazard

- 6) Be sure to put your hand in the proper position on the safety prop when lowering the platform
- 7) Open the limit switch base cover on the chassis.
- 8) Slightly raise the platform and restore the safety prop to the stowed position
- 9) Using the ground controller, elevate the platform while pressing the upper limit switch arm to initialize the upper limit switch. Result: the platform stops elevating and the function of machine is normal. Result: the platform continues to raise. Adjust or replace the upper limit switch.

1.9.16 B-16 Inspection of steering knuckle

- 1) This check item shall be made once per 25h or per month, whichever is shorter.
- 2) The condition of copper gasket of steering system is vital for the safe operation of the

machine. The use of worn copper gasket may result in damage to component and unsafe work risk.

- 3) Please check the copper gasket when the platform is folded.
- 4) Measure the thickness of copper gasket.
 - a) Result:

If the measured result of SS1230E/SS1432E/AS1930E/AS1930/AS1932E/AS1932/SS1932E is not greater than 0.4in(10mm), replace the copper gasket.

If the measured result of AS2632E/AS2632/AS2646E/AS2646/AS3246E/AS3246/AS4046E/AS4046 is not greater than 0.75in(19mm), replace the copper gasket.

- b) Result:

If the measured result of SS1230E/SS1432E/AS1930E/AS1930/AS1932E/AS1932/SS1932E is greater than 0.4in(10mm), apply lubricant between the steering system and copper gasket.

If the measured result of AS2632E/AS2632/AS2646E/AS2646/AS3246E/AS3246/AS4046E/AS4046 is greater than 0.4in(10mm), apply lubricant between the steering system and copper gasket.

- 5) Measure the distance between the chassis bushing and the upper cover plate of steering knuckle.

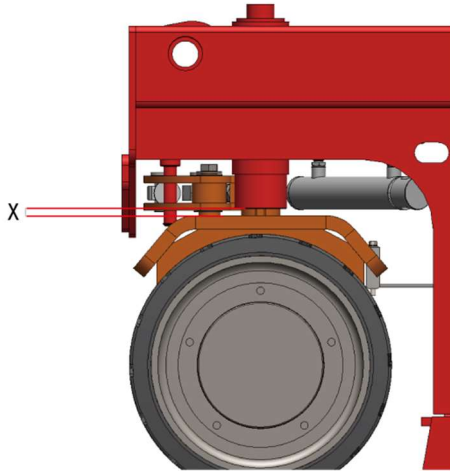

a) Result:

If the measured result of AS1413/AS1413E is not greater than 9mm, replace the nylon gasket.

b) Result:

If the measured result of AS1413/AS1413E is greater than 9mm, not replace the nylon gasket.



Notice: please contact LGMG

North America for copper gasket , if necessary.

1.9.17 B-17 Check and Replacement of Electric Brush



Warning: Charged motor power

system: Be careful when checking brushes; first disconnect battery.

Periodic Check

Check the motor at least once semiannually in the following method:

- 1) Conduct external check, keep the outer surface of the motor clean.
- 2) Open the protective cover and clean carbon deposit.
- 3) Check or replace the bearing, and during running, carefully listen whether or not there is any abnormal noise in the bearing.
- 4) Check the wear of the electric brush, and where appropriate, replace the electric brush.

Table 9 - Fault Analysis and Troubleshooting

Fault	Cause	Troubleshooting
Blackening of commutator, excessive wear of electric brush or large spark	Overload	Reduce loads and operating frequency
	Reduction in pressure caused by seize of electric brush or annealing of spring	Clean carbon deposit, check the cause and replace the spring.
	Inappropriate to electric brush	Replace as per the designation and size of the original electric brush for the motor.
	Serious carbon deposit in the motor	Clean carbon deposit



Fig. 1



Fig. 2



Fig. 3



Fig. 4

Replacement of Electric Brush

1. Remove the window cover plate
 - 1) Unscrew the cover plate screw with the T-wrench, and take the cover plate down.
2. Remove the old electric brush.
 - 1) Unscrew the fastening screw from the tail of the electric brush with the Phillips screwdriver or the socket wrench.
 - 2) Pull the spring, take the old electric brush out of the brush box, and clean carbon dust accumulated on the brush box and the surface of the electric brush.
3. Install the new electric brush
 - 1) Put the new electric brush into the brush box, and hold down the electric brush with the

- spring.
- 2) Fix the tail to the wiring board of the brush box with the Phillips screwdriver or the T-wrench, and screw with the torque wrench.
- 4. Install the window cover plate
 - 1) Insert the cover plate into the card fastener of the window, screw the fastening screw (trimming washer and spring washer), and screw with the torque wrench.

⚠ Notice: Upon the installation of the electric brush, the motor should idle, for the purpose of the wear-in of the arc surface of the electric brush and increase in contact surface between the electric brush and the commutator.

⚠ Notice: Do not run the motor under overload and undervoltage, or else, heavy current is easy to cause due to underrun, resulting in wear of electric brush.

1.10 Checklist C

1.10.1 C-1 Testing the Platform Overload System (If Equipped)

This check item shall be made once every 50 hours of operation or every quarter, whichever interval is shorter. This test and recalibration of the system must be performed immediately when overload failure occurs.

- 1) Testing the platform overload system regularly is essential to the proper operation of the machine. Continuous improper operation of the platform can cause failure of the overload system. Stability of machine will be affected and the possibility of it being tipped over will increase.
- 2) The platform overload system is used for preventing operation of the machine in cases of overload. The system is composed of two electric elements, an overload pressure switch, and an angle sensor.
- 3) The angle sensor in the scissor arm is used for measuring the inclination angle of the scissor and further determining the platform operating height.
- 4) Turn the key switch to the ground controller position. Elevate the platform for a predetermined height above the ground as shown in the following table.

Table 10 - Safety Prop Deployment Height

Model	Height
SS1230E	7.9ft (2.4m)
SS1432E	
AS1930	
AS1930E	
AS1932	
AS1932E	9.09ft (2.77m)
SS1932E	
AS2632	10.5ft (3.2m)
AS2632E	
AS2646	
AS2646E	
AS3246	

AS3246E	13.1ft (4m)
AS4046	
AS4046E	
AS4650	
AS4650E	

- 5) Lift the safety arm, move it to the center of the scissor cross tube and rotate it upward until it is vertical.
- 6) Carefully lower the platform until the safety prop completely contacts the cross tube.



Warning

Crushing Hazard

- 7) Be sure to put your hand in the proper position on the safety prop when lowering the platform.
- 8) Open the limit switch base cover on the chassis.
- 9) Remove the limit switch cover.
- 10) Open the limit switch base cover on the chassis.
- 11) Remove the limit switch cover.
- 12) Tag and disconnect the two electrical lines to the upper limit switch.
- 13) Make a jumper wire to connect the two disconnected lines.
- 14) Turn the key switch to the ground controller position and pull out the emergency stop buttons on both the ground and platform controllers.
- 15) Slightly raise the platform and return the

safety prop to the stowed position.

- 16) Raise the platform to the highest location and continue to press the lifting function selector button. Result: the alarm sounds. System function is normal. Result: No alarm sounds. Calibrate the platform overload system.
- 17) Lower the platform using the manual lowering knob until the platform is stowed.
- 18) Carefully remove the jumper wires from the upper limit switch.
- 19) Raise the platform to the highest location and continue to press the lifting function selector button. Result: No alarm sounds. System function is normal. Result: The sounds and the platform overload system is malfunctioning. Repair or replace the limit switch, its wiring, installation bracket, or calibrate the overload system.
- 20) Lower the platform to a given height above the ground. The height of every model is given in the following table.

Table 11 - Safety Prop Deployment Height

Model	Height
SS1230E	7.9ft (2.4m)
SS1432E	
AS1930	
AS1930E	
AS1932	
AS1932E	9.09ft (2.77m)
SS1932E	
AS2632	10.5ft (3.2m)
AS2632E	

Model	Height
AS2646	10.5ft (3.2m)
AS2646E	
AS3246	
AS3246E	
AS4046	13.1ft (4m)
AS4046E	
AS4650	
AS4650E	

- 21) Lift the safety prop and move it to the center of the scissor cross tube and rotate it upward until it is vertical.
- 22) Carefully lower the platform height until the safety arm completely contacts the cross tube.



Warning

Crushing Hazard

Be sure to put your hand on the proper position of the safety prop when lowering the platform.

- 23) Reconnect the wiring to the limit switch as tagged when it was disconnected and install the limit switch cover.
- 24) Install the limit switch base cover.
- 25) Install the platform limit switch base cover.
- 26) Slightly raise the platform and restore the safety prop to the stowed position.
- 27) Lower the platform to the stowed position.

1.10.2 C-2 Replacement of the Hydraulic Tank Breather Cap

This check item shall be made once every 50 hours of operation or every quarter, whichever interval is shorter.

- 1) The hydraulic oil tank is a ventilated oil tank. An air filter is provided inside the breather cap, which can be blocked over time. If the breather cap is faulty or improperly installed, impurities can enter the hydraulic system which can cause component damage. More frequent inspection is required for hostile or dirty working environment.
- 2) Take off the Hydraulic Tank Breather Cap
- 3) Replace a new breather cap.

1.11 Checklist D

1.11.1 D-1 Inspection of the Scissor Arm Slide Blocks

This check item shall be made once every 100 hours of operation or every six months, whichever interval is shorter.

- The condition of slide blocks on the scissor arm is essential for the proper operation of the machine. The use of worn slide blocks may result in component damage and unsafe work conditions.
- Check the slide blocks when the platform is stowed.
- Measure the distance between the inner arm cross rod and the base plate on the battery side of the non-steer end of the machine.
Result:

- If the measured result of SS1230E/SS1432E/AS1930/AS1930E/SS1932E/AS1932E/AS2632E/AS2646E/AS3246E/AS4046E/AS3246/AS2646/AS4650/AS4650E is not less than 0.94in(24mm), do Step 4.

- If the measured result of AS1932/AS2632/AS4046 is not less than 0.94in(24mm), proceed to step 4.

Result:

- If the measured result of SS1230E/SS1432E/AS1930-AS1930E/SS1932E/AS1932E/AS2632E/AS2646E/AS3246E/AS4046E/AS3246/AS2646/AS4650/AS4650E is less than 0.94in (24mm), replace the slide block.
- If the measured result of AS1932/AS2632/AS4046 is less than 0.9in (22.9mm), replace the slide block.

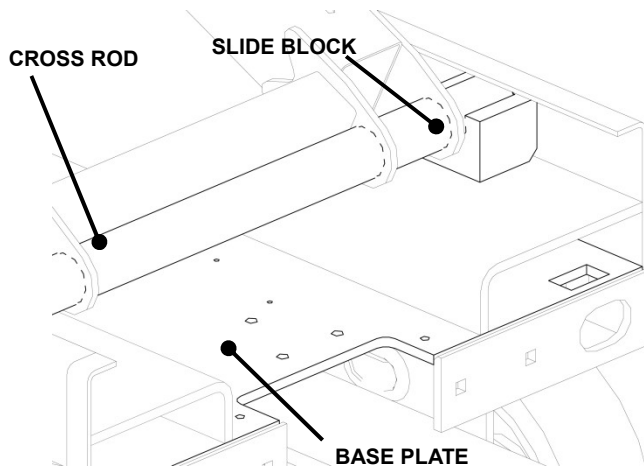

- Apply lubricant between the chassis sliding rail and the slide block.

1.11.2 D-2 Replacement of Oil Return Filter in the Hydraulic Tank

This check item shall be made once every 100 hours of operation or every six months, whichever interval is shorter.



Replacement of the oil return filter is essential to proper performance and service life of the machine. A dirty or blocked filter will affect machine performance and continued use with a dirty filter will cause component damage. The filter must be frequently replaced in hostile or dirty working environments.



Scalding Hazard

Be aware of hot hydraulic oil. Exposure to hot oil may cause severe burns.



The oil return filter is installed at the center of the machine between the control valve block and the hydraulic power unit.

- 1) Clean all dirt and debris from the area around the filter and then remove the filter with a spanner wrench.
- 2) Remove the filter and replace it with a new filter element.

- 3) Apply a coating of hydraulic oil to the filter seal ring and tighten the seal ring by hand.
- 4) Record the time and date of replacement on the filter replacement table.
- 5) Turn the key switch to the ground controller position and pull out the emergency stop buttons from both the ground and platform controllers.
- 6) Activate and hold the lifting function selector button.
- 7) Check the filter for oil leakage.
- 8) Clean up any spilled hydraulic oil.

1.12 Checklist E

1.12.1 E-1 Test and replacement of Hydraulic Oil

This check item shall be made once every 200 hours of operation or every year, whichever interval is shorter.

- 1) The replacement or test of hydraulic oil is essential to proper equipment performance and service life. Contaminated hydraulic oil or a clogged filter can affect the machine performance and potentially damage components. More frequent inspections are required when operating in hostile or dirty working conditions.
- 2) Use an oil separator to check if it is necessary to replace the hydraulic oil.
- 3) If the hydraulic oil has not been replaced for two years, check it once per quarter. Replace the hydraulic oil, if the inspection fails.



Warning

Hydraulic oil under pressure can pierce skin. Slowly unscrew the hydraulic connector to gradually reduce any oil pressure. Do not allow the oil to spray.



Notice

This operation shall be performed with the machine stowed.

- 4) Tag and disconnect the oil return pipe running from the hydraulic filter to the hydraulic oil tank. Remove the pipeline from the oil tank. Cover the pipe joint to keep dirt or debris out.
- 5) Make and disconnected the hydraulic pump and the oil suction pipe of oil tank and take out the oil pipe. Cover the pipe joint to keep away the dust.
- 6) Remove the hydraulic oil tank retaining hardware and remove the hydraulic oil tank.
- 7) Remove the hydraulic oil fill cover and pour the oil in a proper container.
- 8) Clean up any spilled hydraulic oil and properly discard the used hydraulic oil.
- 9) Clean the hydraulic oil tank with mild solvent and allow it to completely dry.
- 10) Install the hydraulic oil tank and secure it in place with the retaining hardware. Torque the retaining bolts to 25 ± 2 N.
- 11) Connect the oil inlet of the hydraulic pump to

the oil tank.

- 12) Connect the oil return pipe of the oil return filter to the hydraulic oil tank.
- 13) Fill the oil tank with hydraulic oil. Do not overfill. Install the tank filler cap
- 14) Start the oil pump to fill the entire hydraulic system with hydraulic oil and bleed the air.



Component Damage Hazard
Operation with no hydraulic oil may damage the hydraulic pump. Take measures to prevent the hydraulic pump from cavitating.



This page left blank intentionally

Chapter 2 Maintenance Schedules

2.1 Battery Maintenance Schedule

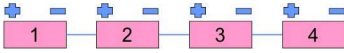
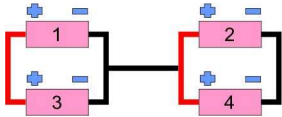
Battery Interchange Maintenance Schedule								
1	Battery Position Anode 1-2-3-4 Cathode Series 							
2	Battery Position Anode 1=3 Cathode 2+4 Series Parallel 							
Purpose	For solving the problem when the No. 1 and No. 4 battery capacities discharge quickly, causing the No. 3 and No. 2 battery performance to be reduced.					Matching Principle	None	
Battery Change Operation Instruction	1	0-25 weeks	26-50 weeks	51-75 weeks	76-100 weeks	101-50 weeks	Calculate the battery performance in the condition of every connection mode, the worse should be put in No. 2 and No. 3 positions. The better batteries should be put in the No. 1 and No. 4 positions.	The interchange principle of the other batteries in Series-Parallel mode is similar.
		1-2-3-4	3-4-1-2	4-2-3-1	2-1-4-3	3-4-2-1		
		Performance Trend (Good- >Bad)						
	2	0-25	26-50	51-75	76-100	101-50		
		1-2-3-4	4-1-2-3	1-2-3-4	4-1-2-3	1-2-3-4		
		Performance Trend (Good- >Bad)						

2.2 Maintenance Schedule

2.2.1 Routine Inspection and Maintenance Intervals

Routine inspection and maintenance interval table

Maintenance level	Routine inspection	Level I	Level II	Level III	Level IV	Level V
Maintenance period	Every day	25h/1m	50h/3m	100h/6m	200h/12m	400h/24m



Notice: Working hours are based on those shown on the hourmeter.

Maintenance items of every level are given in the following tables

Item	Description	Maintenance Level					
		Routine inspection	I	II	III	IV	V
Electric system	Check battery capacity	•	•	•	•	•	•
	Check that all buttons/switches on the PCU panel function normally	•	•	•	•	•	•
	Ensure the PCU emergency stop switch is secure	•	•	•	•	•	•
	Check if all switches operate properly	•	•	•	•	•	•
	Check if any wiring harnesses are damaged	•	•	•	•	•	•
	Ensure the PCU wiring harness connector is secure	•	•	•	•	•	•
	Check if the PCU wiring harness connector is not damaged	•	•	•	•	•	•
	Check if the PCU wiring harness is crimped or damaged	•	•	•	•	•	•
	Check if the pressure switch wiring is secure and not damaged	•	•	•	•	•	•
	Check if the lowering solenoid valve is secure and not damaged	•	•	•	•	•	•
	Check if the wirings of horizon sensor and inclination sensor are secure and not damaged	•	•	•	•	•	•
	Check the position and wiring of every limit switch rocker arm	•	•	•	•	•	•
	Check electric brush wear	Every 6 months(100h)					

Item	Description	Maintenance Level					
		Routine inspection	I	II	III	IV	V
Electric system	Ensure the emergency stop switch, key switch and plug switch on the lowering control panel and their wiring are secure and not damaged	•	•	•	•	•	•
	Ensure the warning lamp and horn function normally	•	•	•	•	•	•
	Ensure the motor, motor controller, relay and ECU wirings are secure and not damaged	•	•	•	•	•	•
	Ensure the wiring of every solenoid valve on the main valve block is secure and not damaged	•	•	•	•	•	•
	Ensure the charger wiring is secure and not corroded	•	•	•	•	•	•
	Ensure the battery posts are secure and not corroded	•	•	•	•	•	•
	Check the battery is secure and not damaged	•					
	Check machine performance and various limit switches	•					
	Check if any connector is loose, damaged or corroded	•	•	•	•	•	•
Hydraulic System	Check if the pressure of the hydraulic system is normal	•	•	•	•	•	•
	Check if the lift system hydraulic pressure is normal	•	•	•	•	•	•
	Check if the steering system hydraulic pressure is normal	•	•	•	•	•	•
	Check if the driving system hydraulic pressure is normal	•	•	•	•	•	•
	Check if any oil line or connector is loose or damaged	•	•	•	•	•	•
	Check all hydraulic cylinders for damage or leaking	•	•	•	•	•	•
	Check every hydraulic valve for damage or leaking	•	•	•	•	•	•
	Check if the yoke oil line is securely fastened or damaged	•	•	•	•	•	•
	Check if the driving oil pipe clip is loose	•	•	•	•	•	•
	Check oil level in the hydraulic tank	•	•	•	•	•	•

Item	Description	Maintenance Level					
		Routine inspection	I	II	III	IV	V
Hydraulic System	Replace the hydraulic oil	Yearly					
	Hydraulic oil return filter element	Every 6 months					
	Check the hydraulic oil tank vent cap for leaks	•	•	•	•	•	•
	Replace the hydraulic oil tank vent cap			•	•	•	
Whole machine	Check the fork sliding block for abnormal noise					•	•
	Check and replace the sliding block					•	•
	Check for loose or damaged bolts or abnormal noise	•					
	Check if any circlip or washer on fork arms are damaged, worn, or missing	•					
	Check if the emergency lowering system operates properly	•					
	Check if the platform, yoke and chassis are deformed or have broken welds	•					
	Check if the paint is excessively chips or peels off	•					
	Check if the decals and safety signs are correct and legible	•					
	Check if the manuals are with the machine	•					
	Machine performance and limit switches operate properly	•					
Lubrication	Lubricate the steering knuckle	Once a month					

2.2.2 Hydraulic Oil Selection and Specifications

Use temperature	Oil type
Minimum air temperature $> 15.8^{\circ}\text{F} (-9^{\circ}\text{C})$	L-HM 46 antiwear hydraulic oil
$(-33^{\circ}\text{C})-27.4^{\circ}\text{F} < \text{minimum air temperature} \leq 15.8^{\circ}\text{F} (-9^{\circ}\text{C})$	L-HV 46 low temperature hydraulic oil
$(-39^{\circ}\text{C})-38.2^{\circ}\text{F} < \text{minimum air temperature} \leq -27.4^{\circ}\text{F} (-33^{\circ}\text{C})$	L-HS 46 ultralow temperature hydraulic oil
Minimum air temperature $\leq -38.2^{\circ}\text{F} (-39^{\circ}\text{C})$	10# aviation hydraulic oil



This page left blank intentionally

Chapter 3 Error Codes and Troubleshooting



When an error code is present, the code will flash once per second on the screens of the ECU and PCU.

3.1 Error Codes

Table 9 - Error Codes

Display	Description	Response
01	System initialization error	Stop all actions
02	System communication error	Stop all actions
03	No machine code is set during the first use	Stop all actions
04	The set code is invalid	Stop all actions
06	Prompt of successful release of the remote parameter	Display alarm only
07	Secondary lock alarm	Disable lifting and running
08	Prompt of successful release of weight calibration data	Display alarm only
09	Incorrect feature configuration settings	Disallow all actions
12	Chassis lifting or lowering button opening error during start	Stop all chassis controls
18	Pothole protection error	Stop lifting and running
27	Proportional solenoid valve failure	Stop lifting and running
31	Pressure sensor error	Stop lifting and running
32	Angle sensor error	Stop lifting and running
33	1412 light load mode data calibration error	No lifting
35	Calibration data error	Display alarm only
36	Low battery alarm	Speed reduced to walking speed after lifting
38	Activated overload function and uncompleted weight calibration error	No lifting
39	The battery level switch detects the low level of the battery.	Display alarm only
40	Alarm of failed ECU and GPS handshake	No lifting or walking
41	Lock vehicle status through platform (only applicable to the ECU with the GPS function)	No lifting
42	Platform left turn button pressing error during start	Display alarm only
43	Platform right turn button pressing error during start	Display alarm only
46	Platform handle enable switch button pressing error during start	Stop platform control

47	“The platform handle is not in the middle position” error during start	The speed is reduced to the speed after lifting
52	Forward coil error	Stop lifting and running
53	Backward coil error	Stop lifting and running
54	Lifting error of lifting coil	Stop lifting and running
55	Lifting error of lowering coil	Stop lifting and running
56	Right turn coil error	Stop lifting and running
57	Left turn coil error	Stop lifting and running
58	Brake coil error (because the brake coil is optional, this function is temporarily shielded)	Stop lifting and running
60	Motor controller error	Stop lifting and running (Triplat only)
61	Electric drive motor controller current sensor error (overheating of running or lifting motor)	Display alarm only
62	Motor controller hardware damage error	Display alarm only
63	Motor controller motor output error	Display alarm only
64	Motor controller SRO error	Display alarm only
65	Motor controller throttle valve error	Display alarm only
66	Motor controller emergency reverse error	Display alarm only
67	Motor controller HPD error	Display alarm only
68	Low voltage alarm	Stop all actions
69	High neutral current (MC is detecting current in the motor, but there shall be no current in this case)	Stop lifting and running
70	The steering input is beyond the range (the improper voltage is in the steering input)	Stop lifting and running
71	Motor controller main contactor error	Stop lifting and running
72	Motor controller overvoltage error	Display alarm only
73	Motor controller heat reduction error	Display alarm only
74	Motor controller motor error	Display alarm only
75	Motor controller pump motor error	Display alarm only
76	Motor controller left drive motor error	Stop lifting and running
77	Motor controller right drive motor error	Triplat prohibits lifting and walking combiacx shows only alarms
78	Pump motor short circuit error	Triplat show only alarms combiacx prohibits lifting and walking
79	Left drive motor short circuit error	Stop lifting and running
80	Alarm of exceeding 80% load	Alarm only
81	Right drive motor short circuit error	Stop lifting and running
82	Left brake coil error	Stop lifting and running
83	Right brake coil error	Stop lifting and running
84	Motor controller short circuit error	Stop lifting and running

85	Brake release switch error	Alarm only
86	Brake release not open error	Alarm only
87	Brake application failure	Alarm only
89	Motor protection open error	Stop lifting and running
90	Alarm of exceeding 90% load	Alarm only
91	Short circuit of left drive motor protection	Stop lifting and running
92	Right drive motor protection short circuit	Stop lifting and running
99	Alarm of exceeding 99% load	Alarm only
OL	Platform overload alarm	Stop all actions
LL	"The machine tilts over the safety limit" error	Stop lifting and running

3.2 Troubleshooting Guide

Table 10 - Troubleshooting Guide

Display	Description
01	System initialization error: The ECU may have fault, replace the ECU.
02	System communication error: Check connection between the communication line and other cables. If fault still exists, please replace the PCU or the ECU.
03	Invalid option setting error: Set proper options for the machine
04	The selected machine code is not within the application range, make selection again based on the model
06	Prompt of successful release of the parameter: Restart it
07	Determine whether the GPS platform issues a car lock command
08	Prompt of successful release of calibration data: Restart it
09	Whether the function bit is not configured
12	Chassis lifting or lowering button opening error during start: Check the wiring of the toggle switch or check whether the toggle switch is jammed.
18	Pothole protection error: Check whether the pothole protection is activated, and check the pothole protection limit switch. Check the wiring of the switch, lower limit switch and wiring.
27	Check that the proportional valve is wired correctly.
31	Pressure sensor error: Check the sensor wiring and the sensor. Check to confirm that the correct machine option with overload detection is selected.
32	Angle sensor error: Check the sensor wiring and the sensor. Check to confirm that the correct machine option with overload detection is selected.
33	1412 light load mode unsuccessful overload weight function data calibration error: Carry out weight calibration again.
35	Check whether the calibration process is reversed
36	Check whether the vehicle voltage is too low and whether it needs to be charged.
38	Error of unsuccessful overload weight function calibration: Carry out weight calibration again.
39	Too low level of the battery: Check the battery level and fill the electrolyte if liquid level is too low. Check

Display	Description
	whether the liquid level switch is installed correctly.
40	GPS reconnection error: Check connection status
41	Release unlocking instruction through platform (only applicable to the ECU with the GPS function)
42	Platform left turn button pressing error during start: Ensure that buttons on the handle are not pressed. If not, consider replacing the handle or the PCU.
43	Platform right turn button pressing error during start: Ensure that buttons on the handle are not pressed. If not, consider replacing the handle or the PCU.
46	Platform handle enable switch button pressing error during start: Ensure that the enable switch on the handle is not pressed. If not, consider replacing the handle or the PCU.
47	“The platform handle is not in the middle position” error during start: Confirm that the handle is in the middle position, and check the middle position parameter setting. If normal, consider replacing the handle or the PCU.
52	Forward coil error: Check the connection of the coil and confirm that it is normal. If normal, check the coil for short circuit or open circuit.
53	Backward coil error: Check the connection of the coil and confirm that it is normal. If normal, check the coil for short circuit or open circuit.
54	Lifting error of lifting coil: Check the connection of the coil and confirm that it is normal. If normal, check the coil for short circuit or open circuit.
55	Lifting error of lowering coil: Check the connection of the coil and confirm that it is normal. If normal, check the coil for short circuit or open circuit.
56	Right turn coil error: Check the connection of the coil and confirm that it is normal. If normal, check the coil for short circuit or open circuit.
57	Left turn coil error: Check the connection of the coil and confirm that it is normal. If normal, check the coil for short circuit or open circuit.
58	Brake coil error: Check the connection of the coil and confirm that it is normal. If normal, check the coil for short circuit or open circuit.
60	Check the motor controller.
61	Cool down the machine, and check the wiring. If the wiring is OK, replace the motor controller
62	Restart the machine, if fault exists, check the root cause; if fault still exists, replace the motor controller
63	Check the wiring, and then restart it, and replace the motor controller if necessary
64	Check whether the motor parameter enable delay is too short, and confirm that the parameter is correct
65	Check the wiring, and ensure that the correct throttle type is selected in the motor controller
66	Ensure that the emergency reverse check parameter in the motor controller is set to off
67	The motor enable delay may be too short, and confirm that parameter of other motor controllers is correct
68	Low voltage error: Check the battery voltage and charge if necessary. Check connection between the battery and the switch, reinforce or clean it. Check whether the voltage of the PCU and the ECU is normal.
69	MC is detecting current in the motor, but there shall be no current in this case. MC thinks that the brake is turned on
70	Adjust the ZAPI and/or check the toggle voltage due to loose wiring
71	Check wiring of main contactor, replace contactor if necessary, or replace motor controller
72	Check the battery voltage, check if it is charging. If the fault still exists, try to replace the motor controller
73	Cool down the restart machine or replace the motor controller

Display	Description
74	Check the wiring of the motor or replace the motor controller
75	Check the wiring of the pump motor, restart the machine or replace the motor controller
76	Check the wiring of the left drive motor, restart the machine or replace the motor controller
77	Check the wiring of the motor, restart the machine or replace the motor controller
78	Check the wiring of the pump motor, restart the machine or replace the motor controller
79	Check the motor connection and ensure that they are tightened, and check the motor for short circuit
80	Alarm of exceeding 80% load: As the platform is close to the load limit, it is not recommended to increase the load.
81	Check the motor connection and ensure that they are tightened, and check the motor for short circuit
82	Check the connection of the coil terminal and ensure that they are tightened, and check whether the coil is connected properly
83	Check the connection of the coil terminal and ensure that they are tightened, and check whether the coil is connected properly
85	Check that the brake connection is correct
86	Check that the brake connection is correct
87	Check that the brake connection is correct
89	Check motor circuit connection status
90	Alarm of exceeding 90% load: As the platform is close to the load limit, it is not recommended to increase the load.
91	Check if the left drive motor is shorted
92	Check if the right drive motor is shorted
99	Alarm of exceeding 99% load: As the platform has reached the load limit, do not to increase the load.
OL	Platform overload alarm: Remove excessive loads immediately.
LL	“The machine tilts over the safety limit” error: If the machine tilts, try to make it recover horizontal status. If the machine is horizontal, check the wiring of the level sensor or the sensor.

Historical error status:

- 1) The controller can display the last 10 error alarm codes recorded. Press the right turn key on top of handle and hold it for 10 seconds (do not press the enable switch of the handle) to log in the historical error status.
- 2) Press the left turn switch to view the previous error code until reaching the first one. Press the right turn switch, to view the historical error code in the reverse sequence until reaching the latest one. For error codes, please refer to the table above.
- 3) Push the enable switch on the handle to recover the normal operation status.



This Page Left Blank Intentionally

Chapter 4 Hydraulic Drive Control System

4.1 Basic Operation

For the following discussions:

Refer to the Platform Control Unit (PCU), Electronic Control Unit (ECU), and Key Switch and Chassis controls Figures as necessary.

4.2 Main Power and Safety

- 1) The Key Switch supplies power to the Emergency Stop (E-Stop) and selection of Chassis control or Platform control. The power is off in the center position and removal of the key in any one of the three positions will maintain the lift in that mode of operation.
- 2) The E-Stop buttons are located on both the chassis and platform controllers. They are connected in series and must be pulled out for normal operation. Pressing either switch turns off power to the chassis and platform. Machine function is based on a completed circuit and pushing in either E-Stop will open the circuit.
- 3) Keep the inspection report for at least 4 years after inspection or as specified by local government laws and regulations.

4.3 Lifting and Lifting Safety

1. The chassis tilt sensor indicates the chassis is either level or not.
2. If equipped with pothole guards, the platform will not rise above a preset height unless the pothole guards are deployed.
3. The measured load must not exceed the ratings assigned to the model of the machine.
4. Raising or lowering the platform can be accomplished from two positions: at the Chassis or from the Platform. The Key Switch selects which control position.
 - a) The Chassis position allows only up and down movement of the platform through the use of the toggle switch on the Chassis.
 - b) The Platform position allows the operator on the platform to select the Lift Mode. The platform will raise when the control lever is moved to the backward, or lower when the control lever is moved to the forward.
5. The Electronic Control Unit (ECU) in the Chassis will sound an alarm and inhibit operation if the platform is overloaded and the Load Sensing Machine Option was selected during set up. See the Machine Options table in this Chapter for more information.
6. There is an option for stopping the platform for a safe descent after halt during lowering if the Descent Delay Machine Option was selected

during set up. See the Machine Options table in this Chapter for more information.

7. Failure of the elevating or lowering valves are reported as a fault code on the LED readout of both the PCU and ECU displays.

4.4 Driving and Driving Safety

1. Driving is controlled only by the Joystick on the PCU when the Key Switch is set to the Platform position.
2. The Drive Mode must be selected and the Enable button on the Joystick engaged.
 - a) The direction and speed are controlled by moving the handle forward or backward.
 - b) “High Speed” or “Low Speed” can be selected while the platform is stowed, but when the platform is elevated (and the pothole guards, if equipped, are down) the lift will only operate in the “Elevated Speed.”
 - c) Specific lift functions are inhibited if platform loads are in excess of machine specifications.
 - d) The motor controller will decrease speeds if it is overheating internally.
 - e) Brakes are applied at all other times.

4.5 Steering and Steering Safety

1. The Key Switch must be in the platform position.
2. Steering is controlled only by the buttons on the top of the Joystick on the PCU.
3. The Drive Mode must be selected and the Enable button on the Joystick engaged.

4.6 Miscellaneous Operations

1. The Hour Meter on the chassis runs when lift or drive functions are enabled.
2. The 2-character LED display on the PCU indicates the battery status, error conditions and setup data.

4.7 Low Power Operation

1. Battery power status is determined by operator settings of the battery levels and is displayed as battery bars on the PCU display, refer to the Battery Monitor table in this Chapter for more information.
2. Two or more battery bars allow normal driving.
3. At one battery bar, travel speed is reduced.

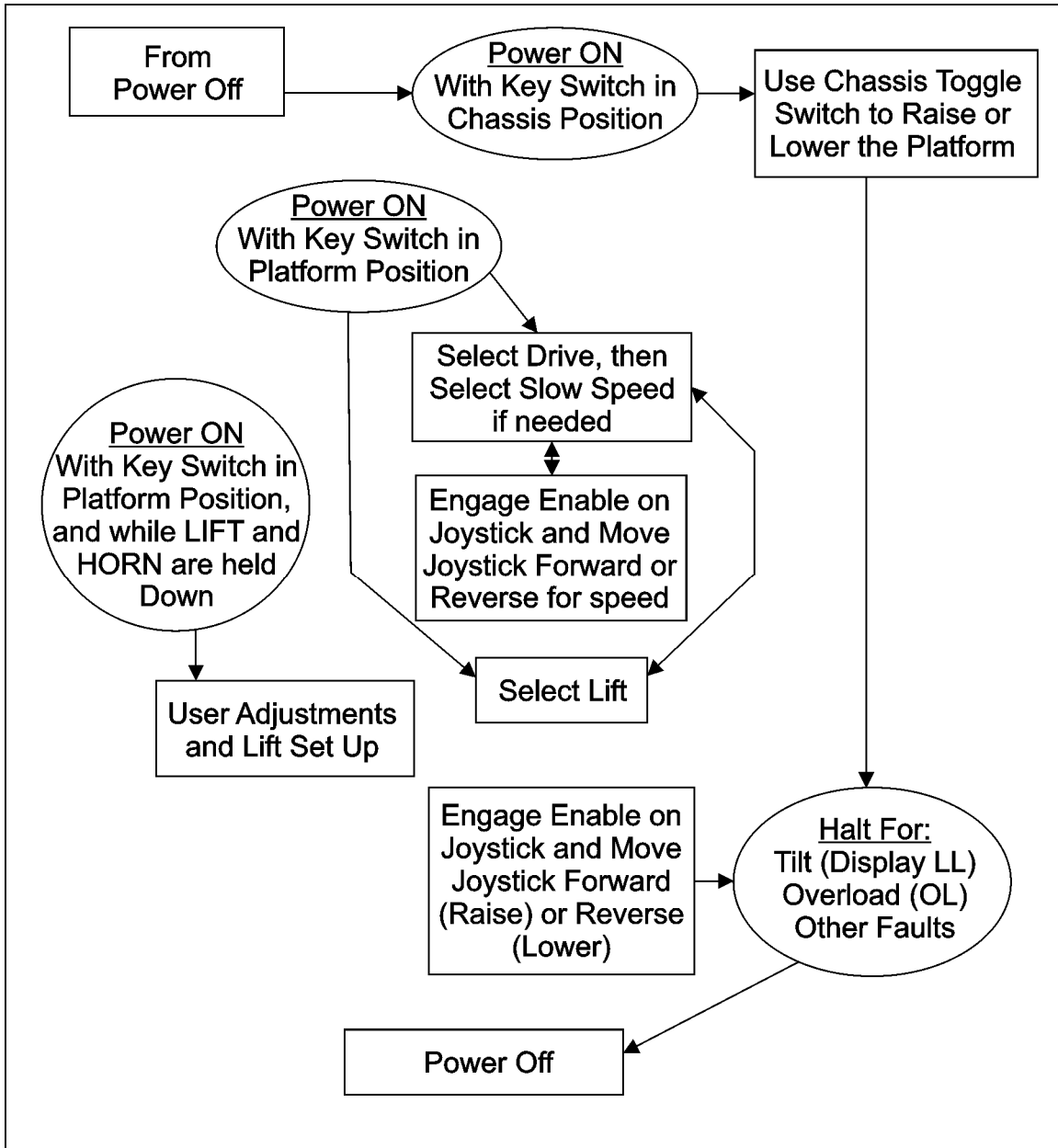

Figure 1 Operation Flow Chart

4.8 Platform Control Unit (PCU) and Electronic Control Unit (ECU)

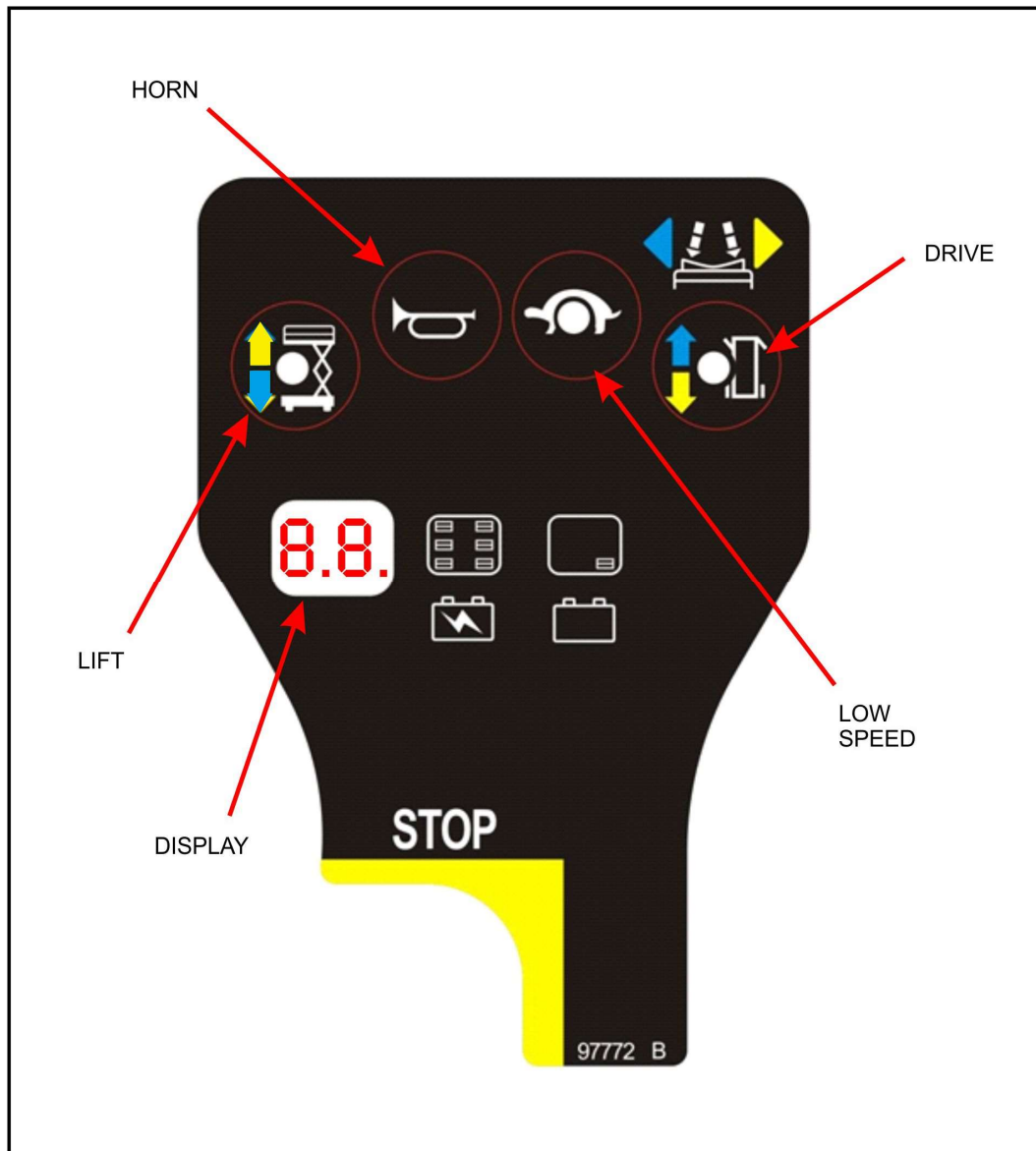

Figure 2 Platform Control Unit

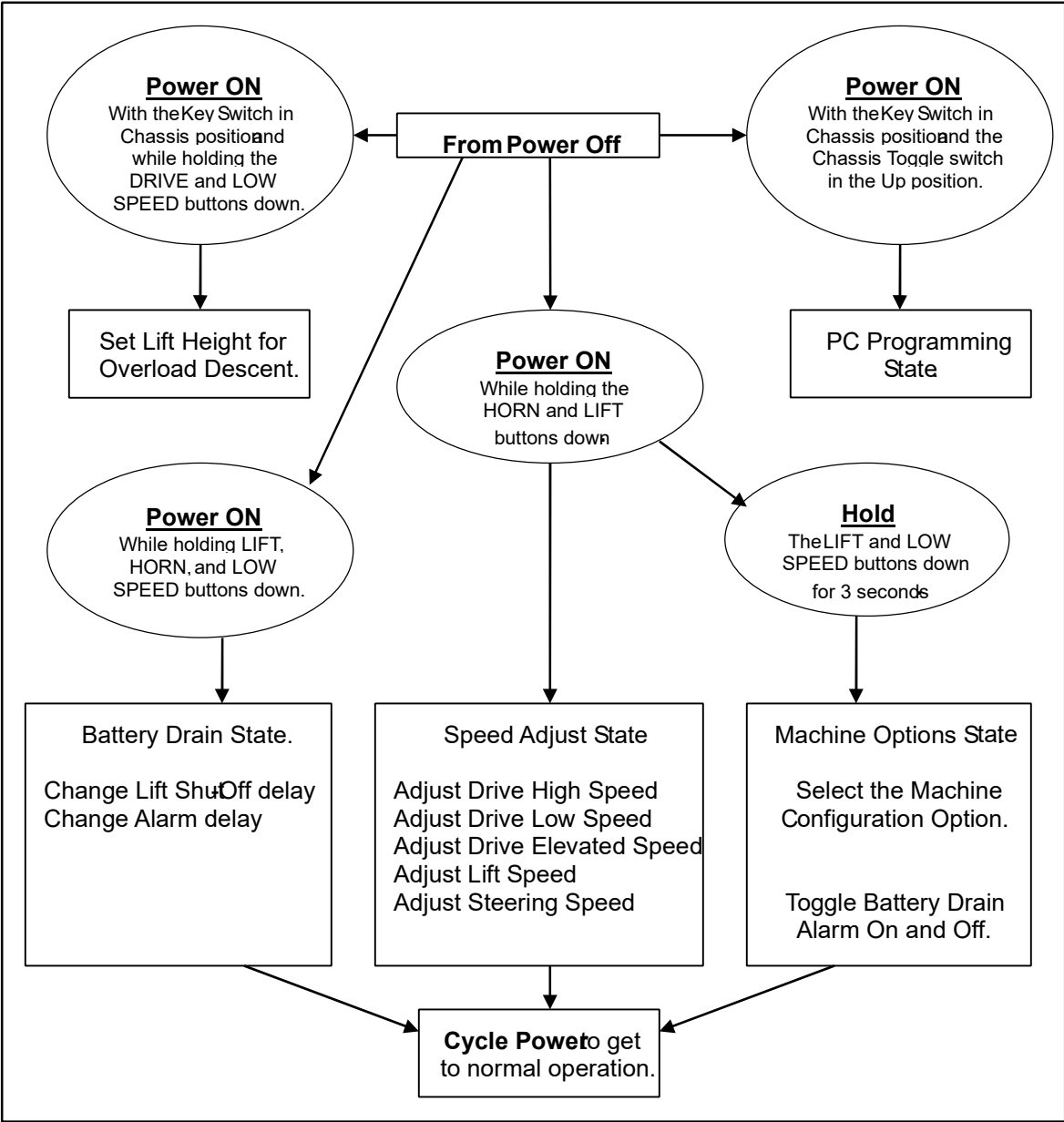

Figure 3 Joystick Control Buttons



Figure 4 Electronic Control Unit (ECU)

4.9 User Adjustments and Lift Set Up



4.10 Battery Drain Shut-Off and Alarm State

The control allows adjusting Shut-Off and Alarm time values for Battery Drain protection.

Start with the E-Stop depressed (in) on the PCU. Turn the Key Switch to the Platform Control position and ensure that the Chassis E-Stop is active (out).

1. Press HORN and Lift and LOW SPEED buttons simultaneously and pull the PCU's Emergency Stop switch out to start Battery Drain Shut-Off and Alarm State.

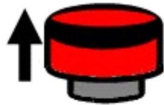
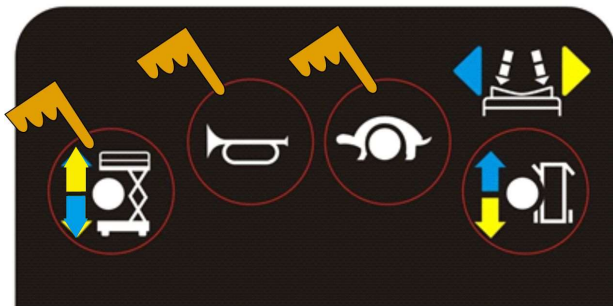

2. "PS" and current Lift Speed are alternately flashing on the display.

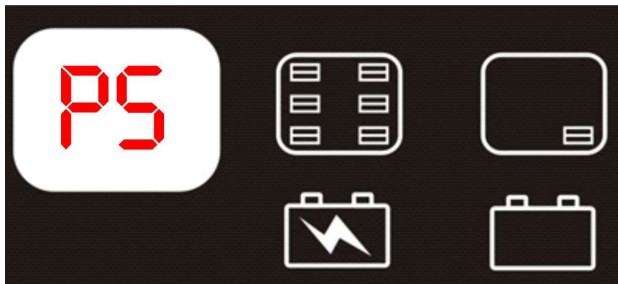

3. Release HORN and LIFT while keeping LOW SPEED depressed until the blinking "PS" disappears and the current Shut-Off value is displayed.

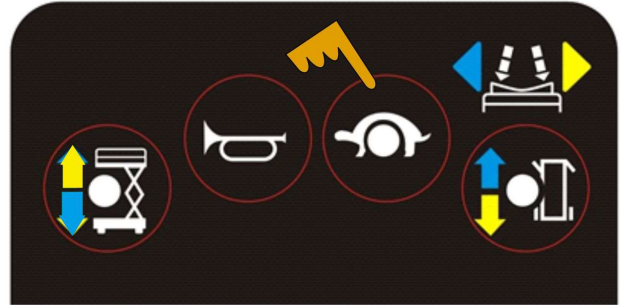

4. The current setting is displayed and two "dots" will be displayed in this mode. Note: factory setting is "00" which is the "OFF" state.

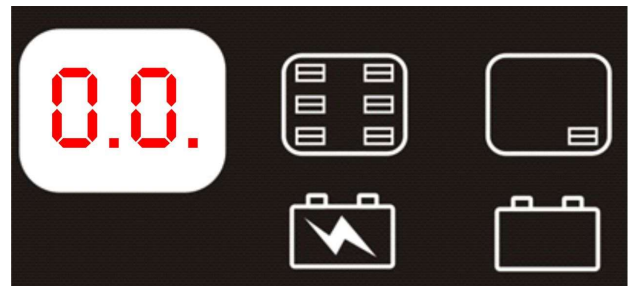

Note: In the Battery Drain Protection adjustment state, both "dots" are displayed.

The battery drain alarm alerts the user that power is being drawn from the batteries.

- A. After [Alarm Time, in minutes] of no activity-alarm starts beeping. Any activity will silence the alarm and allow continued operation
- B. After [Shut-Off Time, in minutes] of no activity-System goes into very low power Sleep mode. Cycle power to restore normal operation.

The system will continue to drain the batteries in the low power mode. The operator or mechanic should assure that power is turned off and the batteries are put on the charger at the end of each working shift or day.

4.11 Change Shut-Off Delay

1. Press LIFT button. The LIFT LED indicates this mode is active.
Adjust the delay using the RIGHT TURN (increase) or LEFT TURN (decrease) button on the top of the Joystick. Refer to Figure 3.

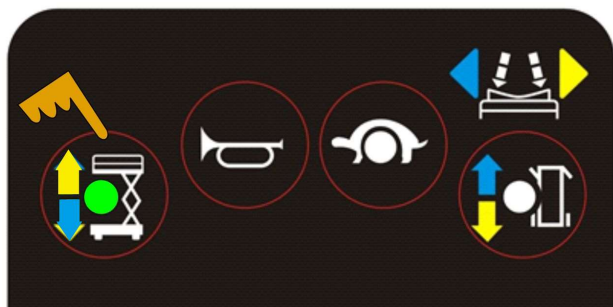

2. The value can be changed from 00 to 60 with the buttons on top of the Joystick.
00 = Disabled



4.12 Change Alarm Delay

NOTE: If the Alarm is not working, it may need to be enabled. The Battery Drain Alarm can be turned on or shut off while in the "SC" mode by pressing the HORN button. Refer to Machine Options State in this Chapter for more information.

1. Press DRIVE button. The DRIVE MODE LED indicates this mode is active.
2. Adjust the time using the RIGHT TURN (increase) or LEFT TURN (decrease) button on the top of the Joystick. Refer to Figure 3.

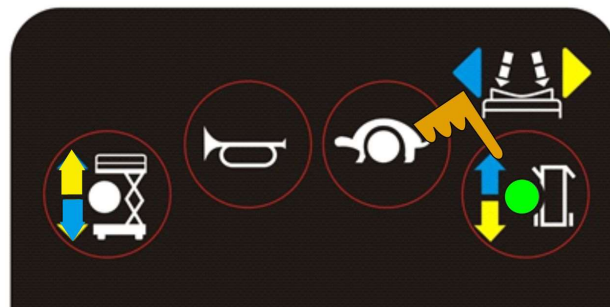

3. The value can be changed from 00 to 60 with the buttons on top of the Joystick.
00 = Disabled



4.13 Speed Adjust State

The control allows adjusting high and low speed drive values. The Drive Speed for normal and elevated travel can be changed from the PCU. The following panels show how to select an individual function to change.

Start with the E-Stop depressed (in) on the platform controller.

Turn the Key Switch to the Platform Control position and ensure the Chassis E-Stop is active (out).

1. Press and hold HORN and LIFT buttons while pulling the PCU's E-Stop (out) to enter Speed Adjust State.

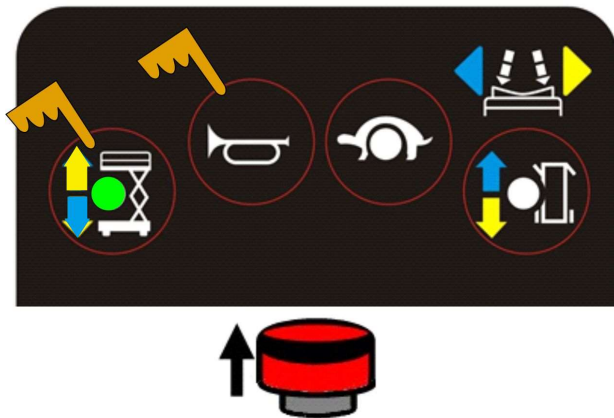

2. "PS" and current Lift Speed are alternately flashing on the display.

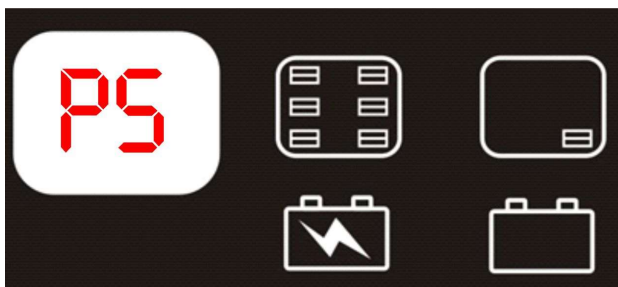

4.14 Drive High Speed (with Platform Stowed)

1. Press DRIVE button. The DRIVE LED indicates this mode is active.
2. Adjust the speed using the RIGHT TURN (increase) or LEFT TURN (Decrease) button on the top of the Joystick.

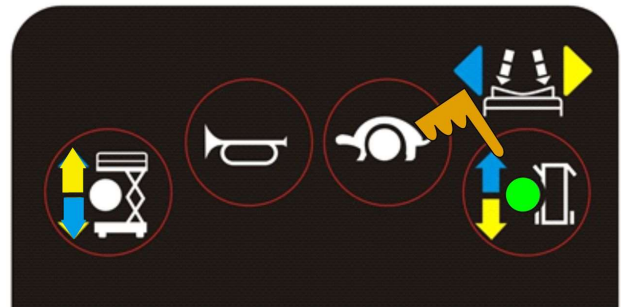

3. The value can be changed from 00 to 100 (displays 9'9) with the buttons on top of the Joystick.



4.15 Drive Low Speed

1. Press DRIVE button.
2. Press and hold the LOW SPEED button to select Drive Low Speed adjustment. Keep it held while adjusting the speed.
3. The display indicates present set value.

Adjust using the RIGHT

TURN (increase) or LEFT TURN (decrease) button on top of the Joystick.

Refer to Figure 3.

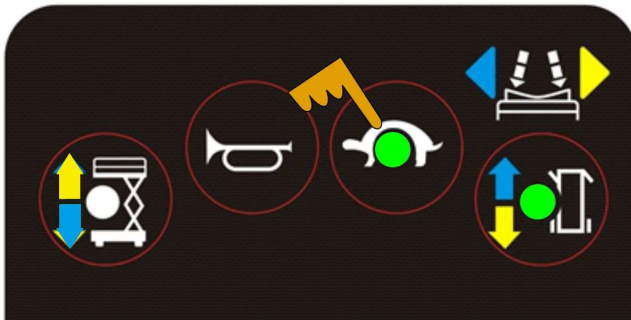

4. The value can be changed from 00 to 100 (displays 9'9) with the buttons on top of the Joystick.



4.16 Drive Elevated Speed

1. Press DRIVE button.
2. Press and hold the HORN button to select Drive Elevated Speed adjustment. Keep it held while adjusting the speed.
3. The display will indicate the present set value.

Adjust the speed using the

RIGHT TURN (increase) or LEFT TURN (decrease)

button on top of the Joystick.

Refer to Figure 3.

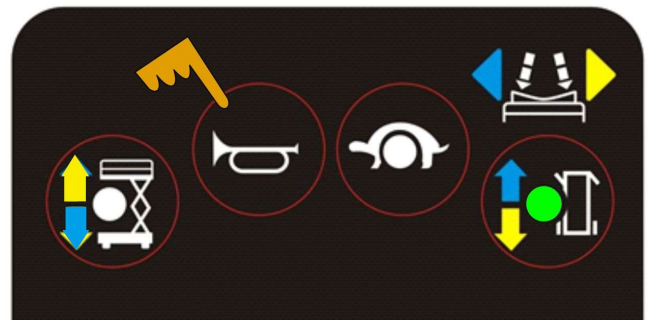

4. The value can be changed from 00 to Max Speed 70 with the buttons on top of the Joystick.



4.17 Lift Speed

1. Press LIFT button. The LIFT LED indicates this mode is active.
2. Adjust the speed using the RIGHT TURN (increase) or LEFT TURN (decrease) button on top of the Joystick. Refer to Figure 3.

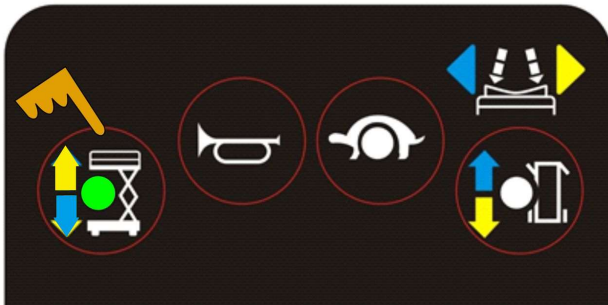

The value can be changed from 00 to 100 (displays 9'9) with the buttons on top of the Joystick.

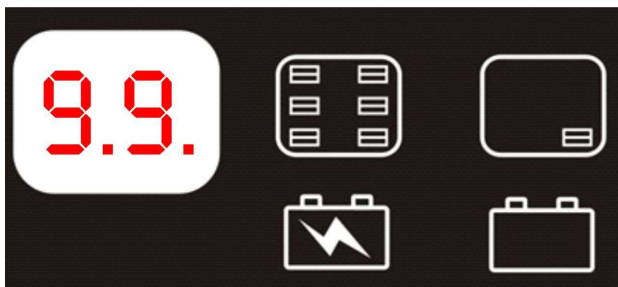

4.18 Steering Speed

1. Press DRIVE button.
2. Press and hold the HORN and LOW SPEED buttons to select Drive Steering Speed

adjustment. Hold these buttons while adjusting the speed.

3. Display indicates the present set value. Adjust the speed using the RIGHT TURN (increase) or LEFT TURN (decrease) button on top of the Joystick. Refer to Figure 3.

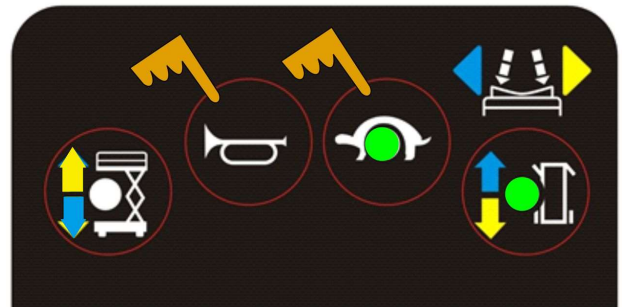

4. The value can be changed from 00 to 100 (displays 9'9) with the buttons on top of the Joystick.

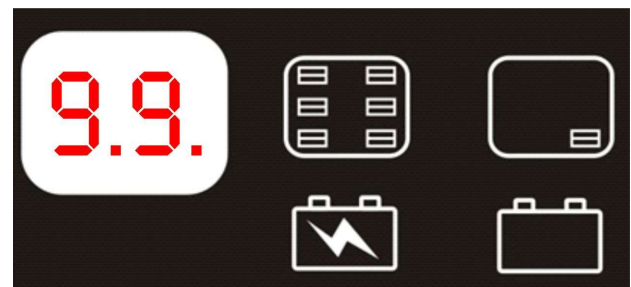

The lift can now be powered down (push E-Stop in on the PCU) and the new values will be available for future operation.

4.19 Fault State

In the fault state, a fault code from the list will be displayed flashing once a second on both the PCU and the ECU displays.

Table 1: List of Fault Codes

Display	Description	Lift Reaction
01	System Initialization Fault	Disables All Motion
02	System Communication Fault	Disables All Motion
03	Invalid Option setting Fault	Disables All Motion
12	Chassis Toggle Switch ON at power-up Fault	Disable Chassis Control
18	Pothole Guard Fault	Disable Lifting and Driving
31	Pressure Sensor Fault	Disables All Motion
32	Angle Sensor Fault	Disables All Motion
42	Platform Left Turn Switch ON at power-up Message	Diagnostic Message Only
43	Platform Right Turn Switch ON at power-up Message	Diagnostic Message Only
46	Platform Joystick Enable Switch ON at power-up Fault	Disable Platform Control
47	Platform Joystick not in neutral at power-up Message	Lift Slows to Elevated Speed
52	Forward Coil Fault	Disable Lifting and Driving
53	Reverse Coil Fault	Disable Lifting and Driving
54	Lift Up Coil Fault	Disable Lifting and Driving
55	Lift Down Coil Fault	Disable Lifting and Driving
56	Right Turn Coil Fault	Disable Lifting and Driving
57	Left Turn Coil Fault	Disable Lifting and Driving
58	General Brake Coil Fault (presently disabled because the brake output is optional)	Disable Lifting and Driving
68	Low Voltage Fault	Disable All Motion
80	Over 80% Load Warning	Warning Only
90	Over 90% Load Warning	Warning Only
99	Over 99% Load Warning	Warning Only
0L	Overloaded Platform Fault	Disable All Motion
LL	Machine Tilted Beyond Safe Limits Fault	Disable Lifting and Driving

Table 2: Troubleshooting Guide

Display	Description
01	System Initialization Fault: ECU may be malfunctioning, replace it.
02	System Communication Fault: Check communications cable connections and other wiring. If that does not resolve the problem, try replacing the PCU or ECU.
03	Invalid Option setting Fault: Set appropriate option for this lift.
12	Chassis Toggle Switch ON at power-up Fault: Check wires to the Toggle Switch or look for a stuck Toggle Switch.
18	Pothole Guard Fault: Check that the pothole guards are extended, check the pothole limit switches. Check wires to the switches, check the down limit switch and connections.
31	Pressure Sensor Fault: Check the wiring to the sensor and then the sensor itself. Also check to make sure that the correct option is properly selected (or not) for load sensing.
32	Angle Sensor Fault: Check the wiring to the sensor and then the sensor itself. Also check to make sure that the correct option is properly selected (or not) for load sensing.
42	Platform Left Turn Switch ON at power-up Message: Ensure that nothing is holding the Joystick Toggle Switches down. If OK, consider replacing the Joystick or PCU.
43	Platform Right Turn Switch ON at power-up Message: Ensure that nothing is holding the Joystick Toggle Switches down. If OK, consider replacing the Joystick or PCU.
46	Platform Joystick Enable Switch ON at power-up Fault: Ensure that nothing is holding the Enable switch closed. If OK, consider replacing the Joystick or PCU.
47	Platform Joystick not in neutral at power-up Message: Make sure that the Joystick is in the neutral (upright) position. Check the neutral zone parameter setting in the LabView Programmer. If it's OK, consider replacing the Joystick or the PCU.
52	Forward Coil Fault: Check the connections to the Coil's terminals and make sure they are tight. If so, check the coil itself to see if it is open or shorted.
53	Reverse Coil Fault: Check the connections to the Coil's terminals and make sure they are tight. If so, check the coil itself to see if it is open or shorted.
54	Lift Up Coil Fault: Check the connections to the Coil's terminals and make sure they are tight. If so, check the coil itself to see if it is open or shorted.
55	Lift Down Coil Fault: Check the connections to the Coil's terminals and make sure they are tight. If so, check the coil itself to see if it is open or shorted.
56	Right Turn Coil Fault: Check the connections to the Coil's terminals and make sure they are tight. If so, check the coil itself to see if it is open or shorted.
57	Left Turn Coil Fault: Check the connections to the Coil's terminals and make sure they are tight. If so, check the coil itself to see if it is open or shorted.

Display	Description
58	General Brake Coil Fault: Check the connections to the Coil's terminals and make sure they are tight. If so, check the coil itself to see if it is open or shorted.
68	Low Voltage Fault: Check battery voltage and charge if necessary. Check the battery connections and tight or clean. Check the voltage to the ECU and PCU.
80	Over 80% Load Warning: Platform is getting close to its limit of weight. Consider not adding more load.
90	Over 90% Load Warning: Platform is getting close to its limit of weight. Consider not adding more load.
99	Over 99% Load Warning: Platform has reached its limit of weight. Do not add more load.
0^	Overloaded Platform Fault: Remove the excess load immediately.
^^	Machine Tilted Beyond Safe Limits Fault: If the machine is tilted, find a way to make it level. If the machine is level, check the wiring to the tilt sensor and then the sensor itself.

4.20 Fault History State

The control allows the displaying of the last 10 faults. Holding down the RIGHT TURN button on the top of the Joystick for 10 seconds (**Without** engaging the ENABLE button) enters the Fault History state.

The LEFT TURN button scrolls through the fault history from the most recent to the oldest event occurred while the RIGHT TURN button scrolls in the opposite direction from the oldest to the most recent fault. Refer to the Fault Code table in this Chapter.

Engaging the ENABLE button on the Joystick returns the display to normal operation.

4.21 Normal Operating State

After setting each of the desired parameters the lift can now be operated as desired.

4.21.1 Driving Forward or Backward with the Platform Stowed

Place the Key Switch in the platform position and pull out both the Chassis E-Stop switch and the PCU E-Stop switch. Momentarily press the DRIVE button on the PCU. Pull in on the ENABLE switch of the Joystick and then push the Joystick forward for forward movement and backward for backward movement. The farther the Joystick is pushed in either direction the faster the lift will move. Pushing down on the LEFT TURN button or the RIGHT TURN button on the top of the Joystick will allow the operator to steer the lift.

4.21.2 Raising or Lowering the Platform

From the Platform Using the PCU

With the lift stationary and with the lift in platform mode push the LIFT button on the PCU. The platform can now be lowered by pushing forward on the Joystick while the ENABLE switch is engaged (i.e. pulled in). Pulling back on the Joystick with the ENABLE engaged will raise the platform.

From the Ground Using Chassis Controls

Turn the Key Switch to Chassis Position.

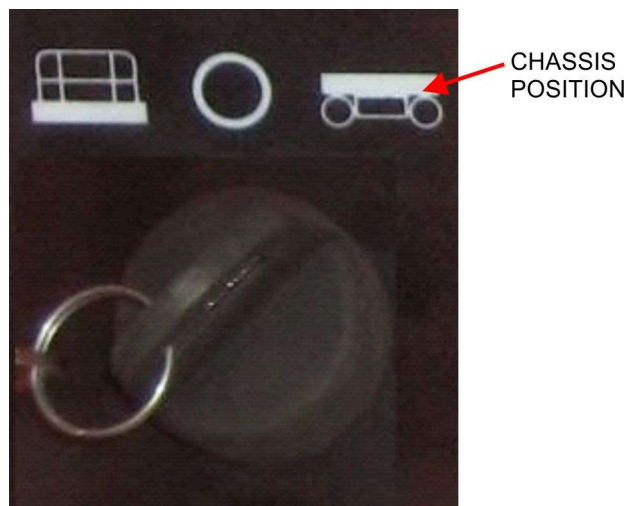

1. Once in Chassis mode the platform will blink "CH" on its display.



2. Move the Chassis Toggle Switch up or down to raise or lower the Platform.



4.21.3 Software Revision and Machine Option Displayed

The ECU displays the Machine Options setting and Software Revision when raising and lowering the platform in normal operation. Note: If errors are present these software states will not be displayed.

The Machine Option number will be displayed on the ECU as the Platform rises.



The Software Revision number will be displayed

on the ECU as the Platform lowers.



4.22 Operating the Lift with the Platform Elevated

Driving the lift while the platform is elevated is the same as driving it when the platform is stored except that the machine will not allow itself to move as fast in either direction. This is for operator safety reasons. Press the DRIVE button and operate the lift with the Joystick as before, again the lift will need to be in the platform mode.

4.23 Displays on the PCU and ECU in normal operation

The following table shows what you can expect to see on the PCU and ECU displays during normal operation:







Table 3: Displays on the PCU and ECU

Operating Mode	PCU Display	ECU Display
Powered up but not Moving	Battery Level	- -
Driving Forward or Backward	Battery Level	- -
Elevating the Platform	Battery Level	Machine Option code
Lowering the Platform	Battery Level	Software Version is Displayed
Faults in either Platform or Chassis Mode	Fault Code	Fault Code
In Chassis Mode	c h	C h

4.24 Battery Charge State

In normal operating mode after proper initialization, the battery charge level is presented on the PCU display in percentage: 10, 20, 30, 50, 70, and 90. At 10% the display flashes every second.

Table 4: Battery Monitor

Platform Display	Battery Percent	Description
	90-100	Battery is fully charged
	70	percent of battery charge
	50	percent of battery charge
	30	percent of battery charge
	20	Must Charge Battery
	10	Very low charge. (Note: Lift operates at low speeds automatically)

Chapter 5 Schematics

SS1230E HYDRAULIC SCHEMATIC

SS1230E Hydraulic schematic

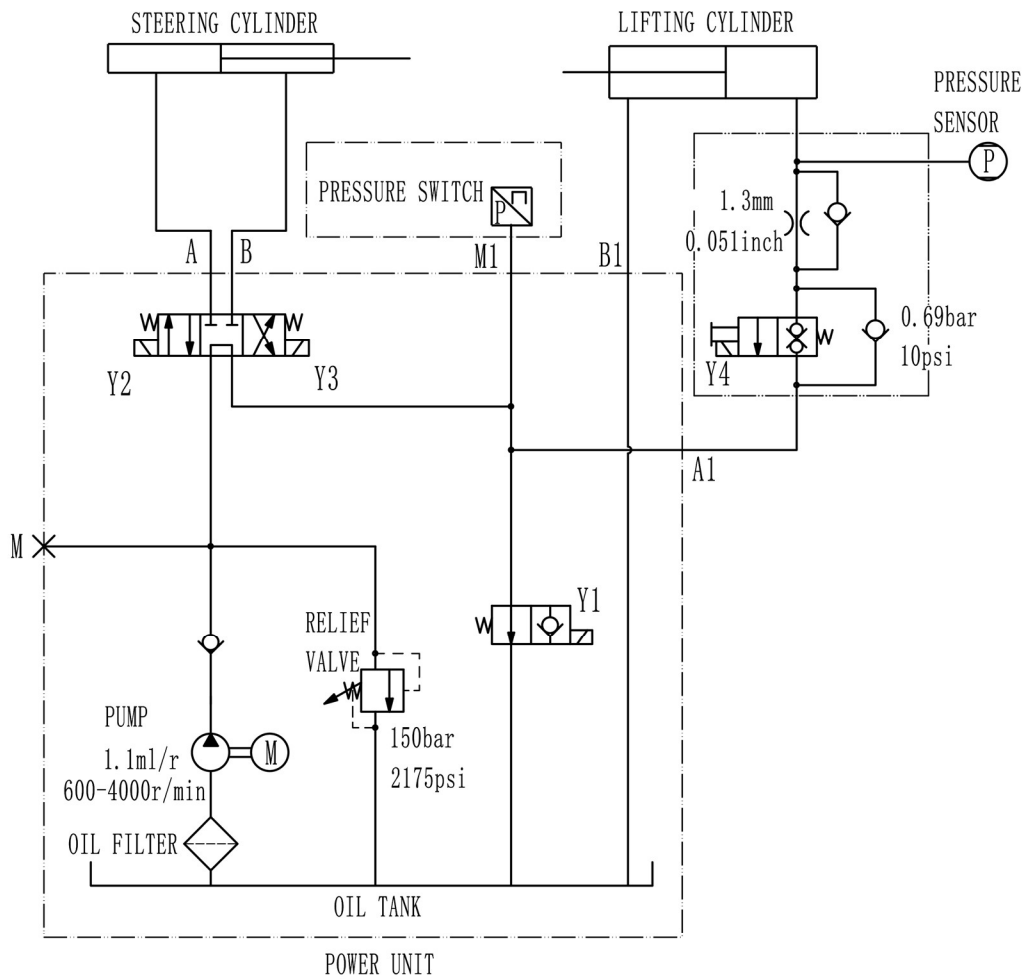

SS1432E HYDRAULIC SCHEMATIC

SS1432E Hydraulic schematic

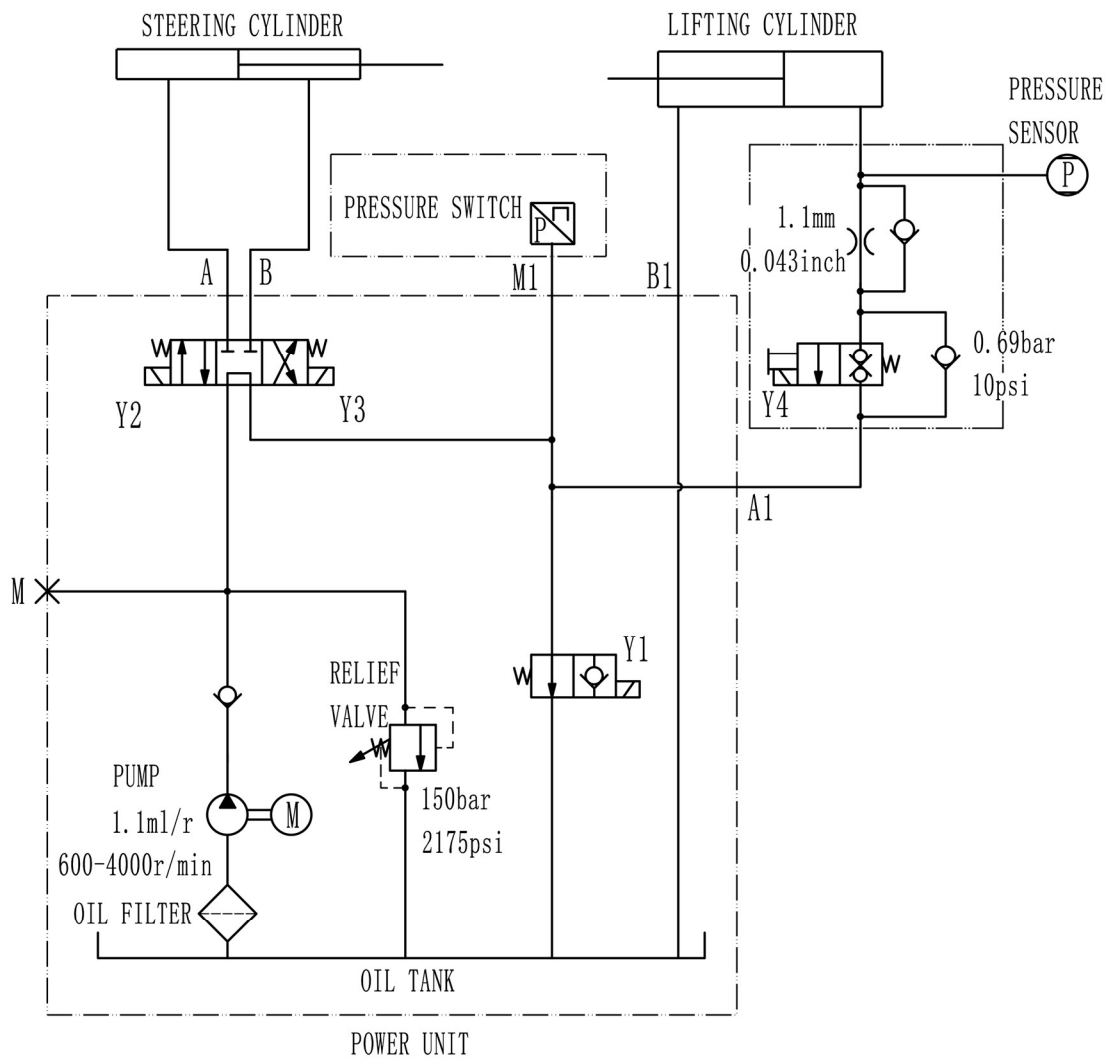

AS1930E HYDRAULIC SCHEMATIC

AS1930E Hydraulic schematic

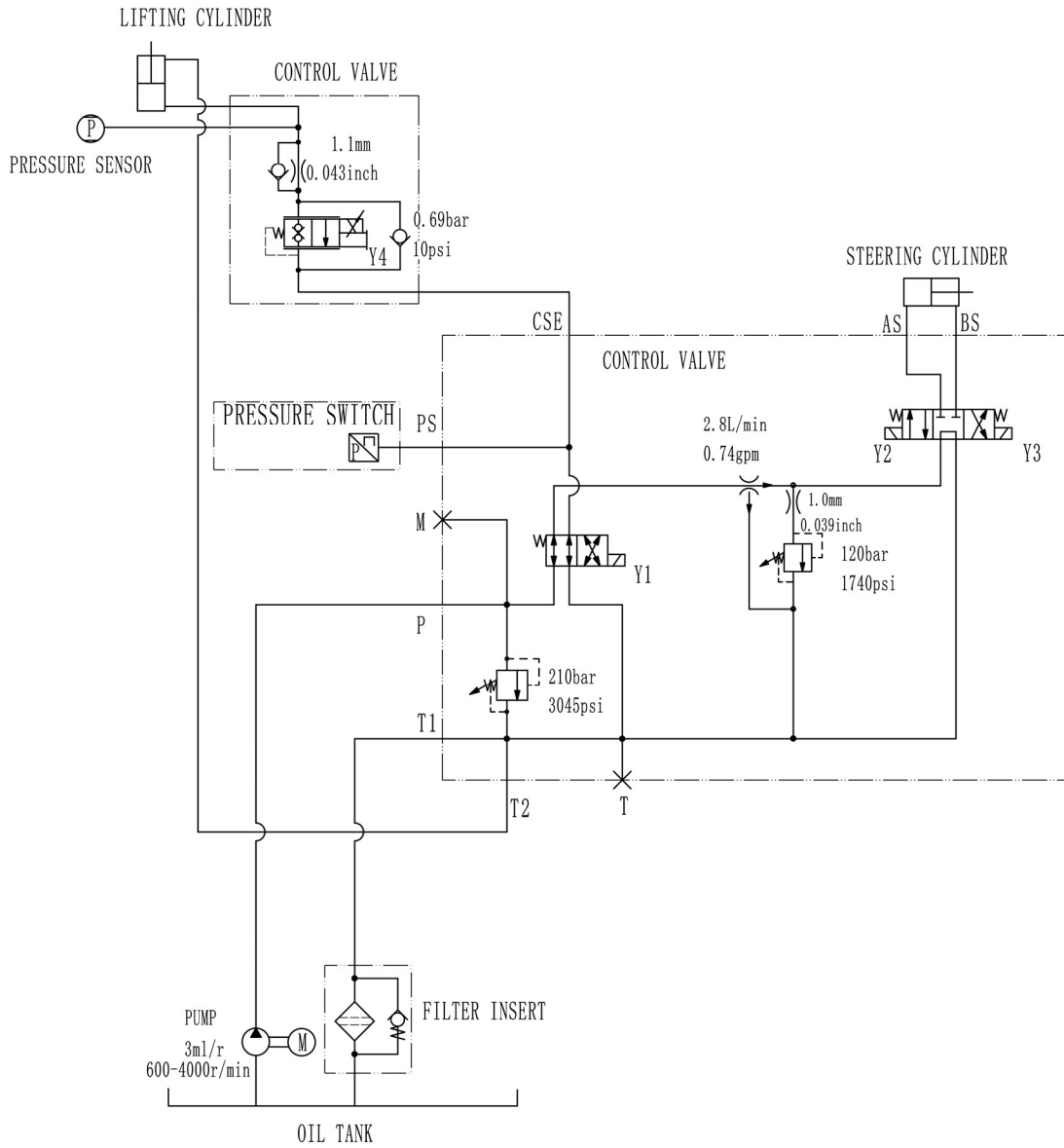

AS1930 HYDRAULIC SCHEMATIC

AS1930 Hydraulic schematic

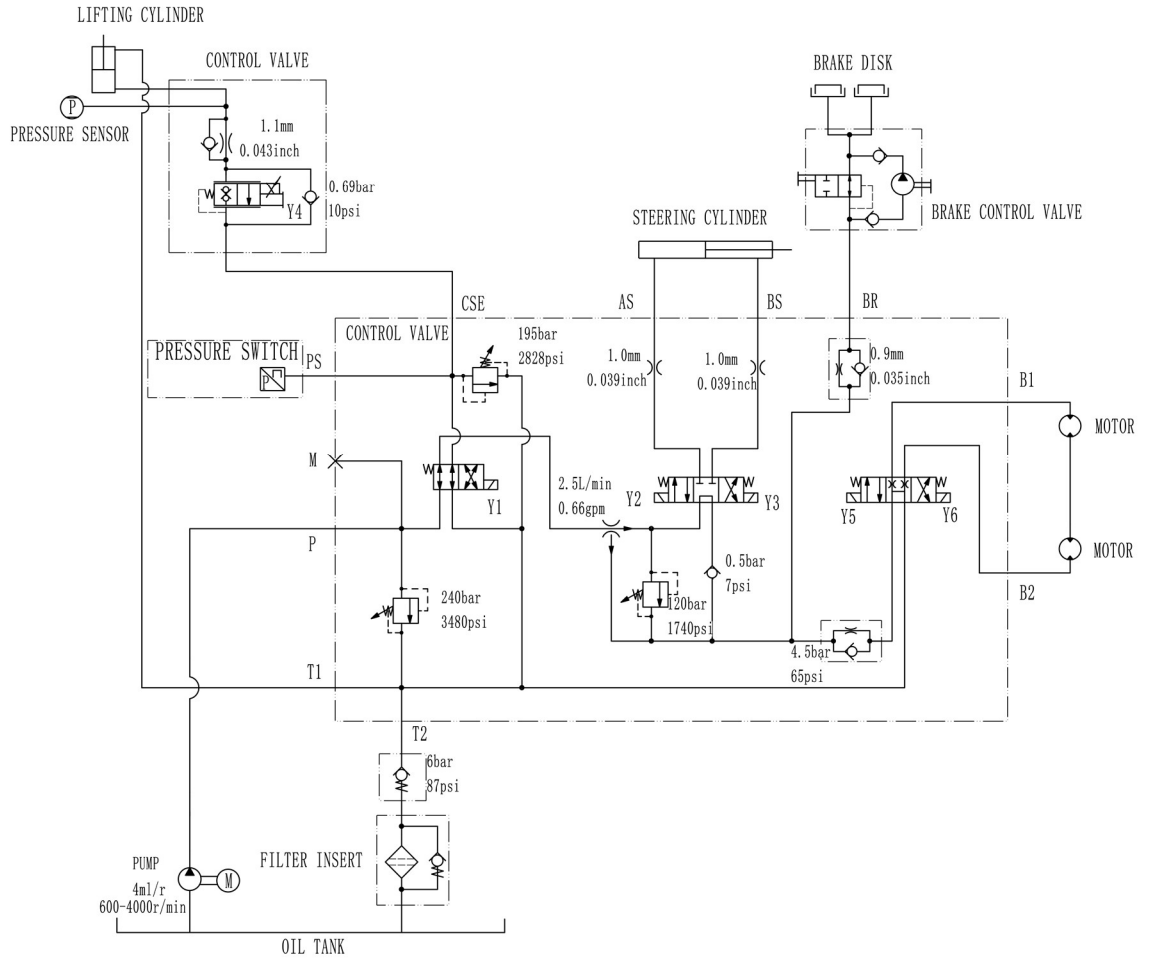

AS1932E HYDRAULIC SCHEMATIC

AS1932E Hydraulic schematic

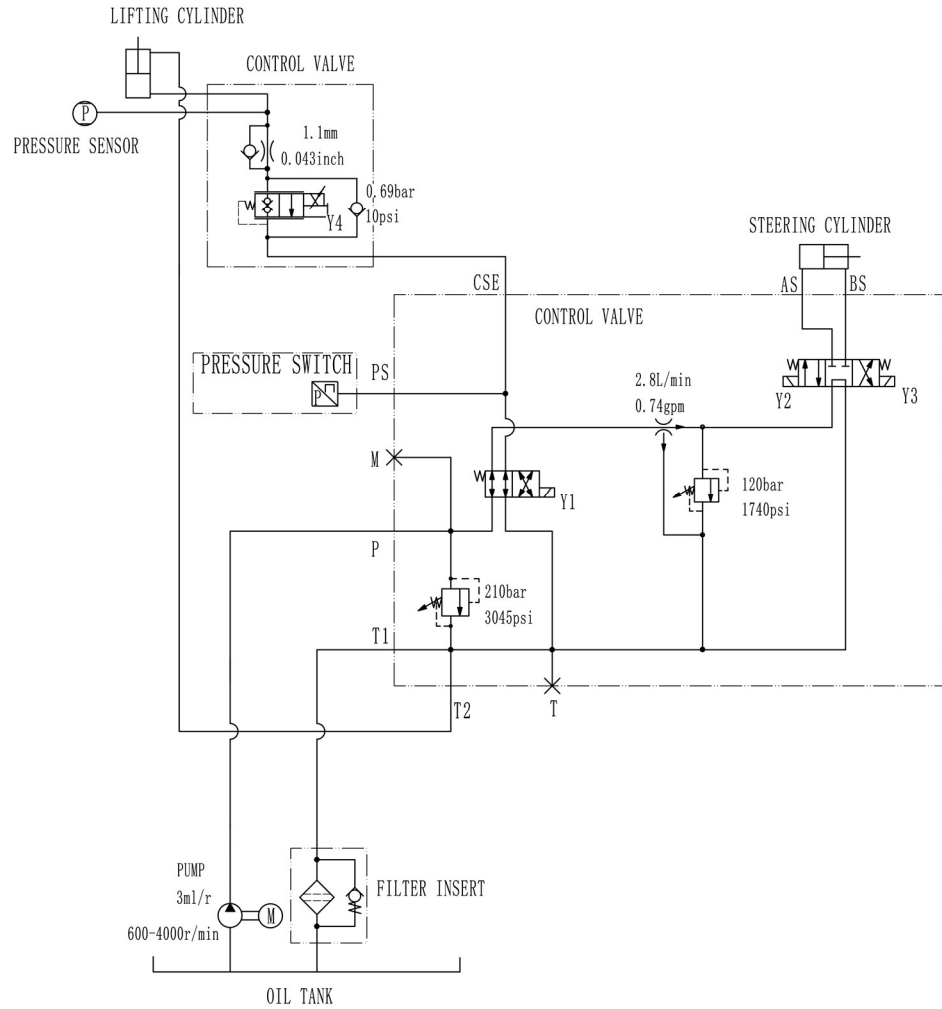

AS1932 HYDRAULIC SCHEMATIC

AS1932 Hydraulic schematic

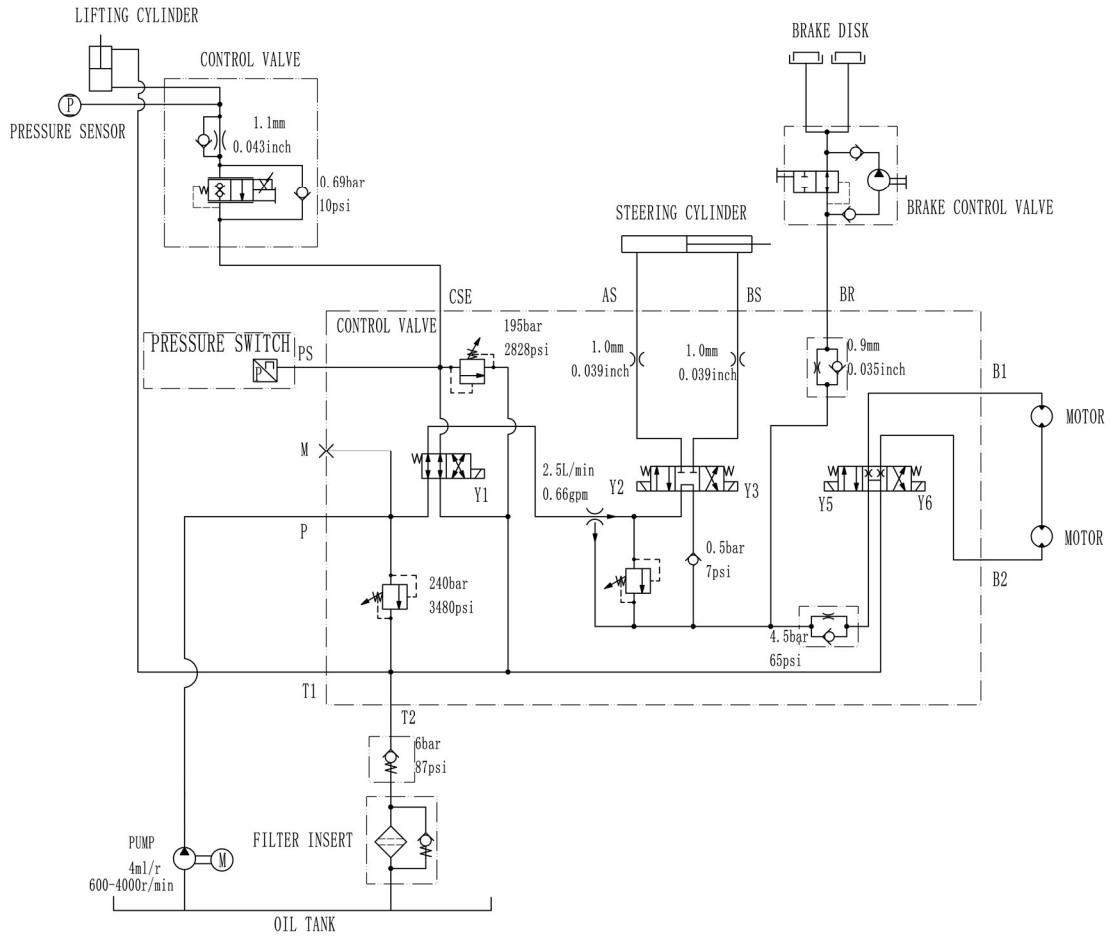

SS1932E HYDRAULIC SCHEMATIC

SS1932E Hydraulic schematic

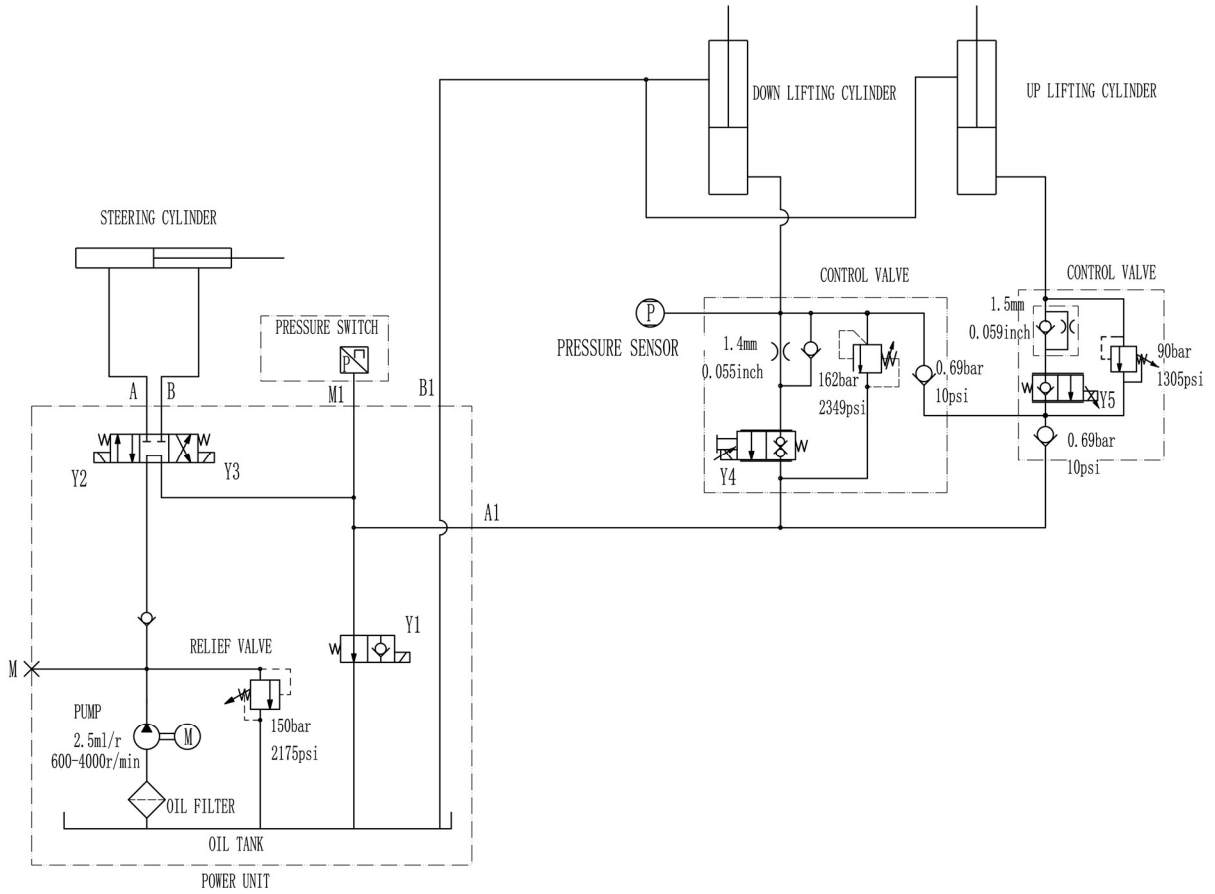

AS2632 HYDRAULIC SCHEMATIC

AS2632 Hydraulic schematic

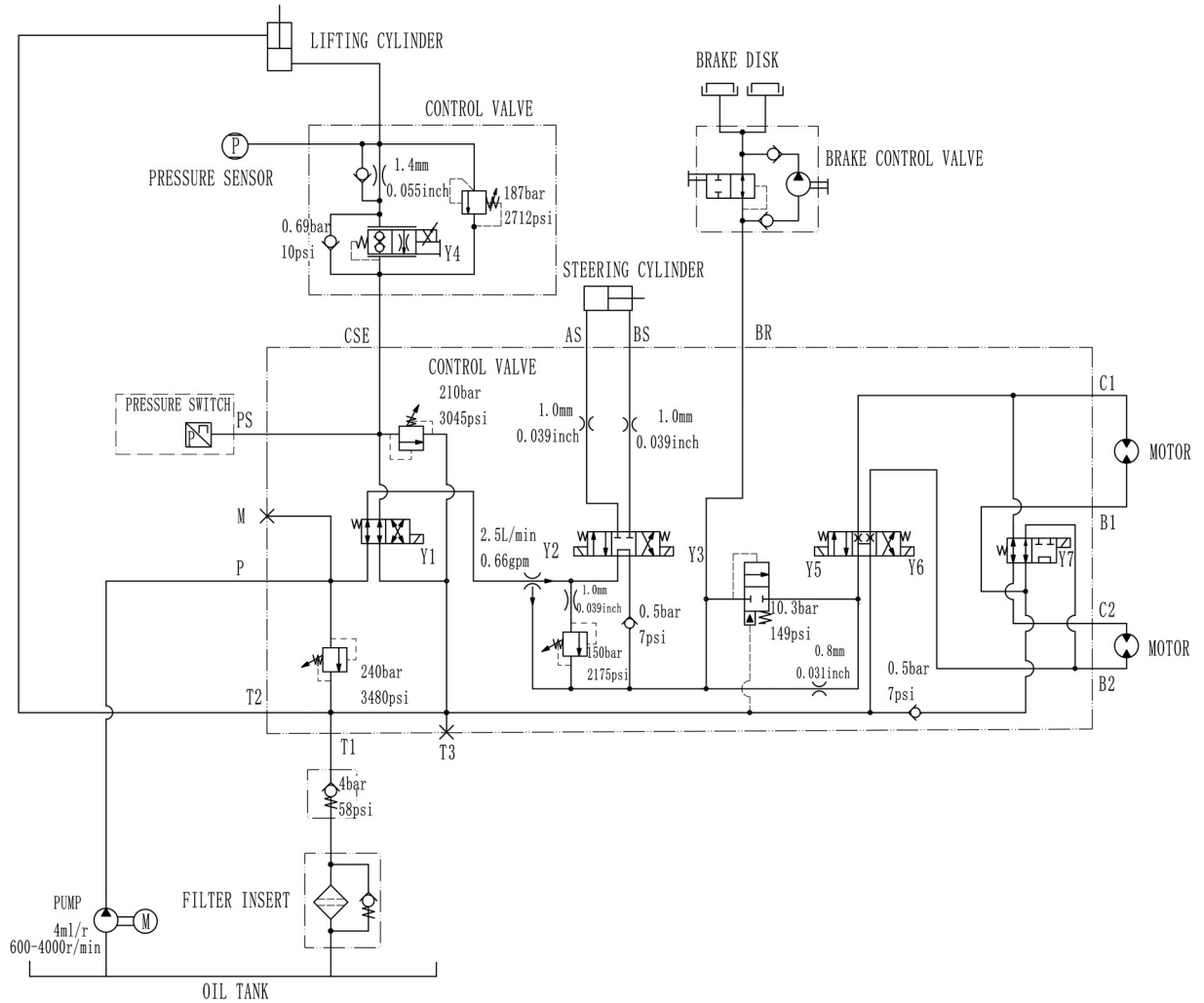

AS2632E HYDRAULIC SCHEMATIC

AS2632E Hydraulic schematic

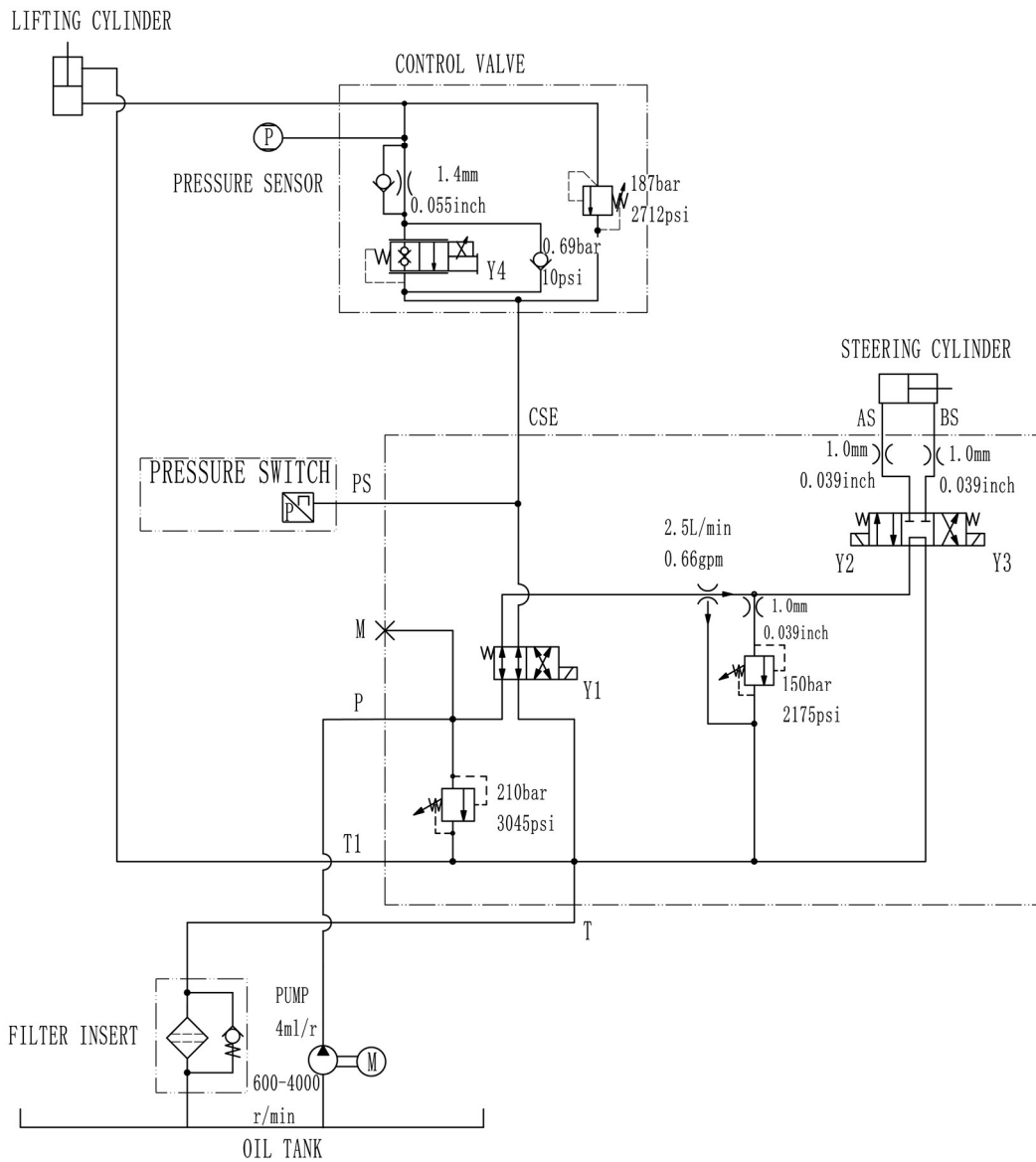

AS2646E HYDRAULIC SCHEMATIC

AS2646E Hydraulic schematic

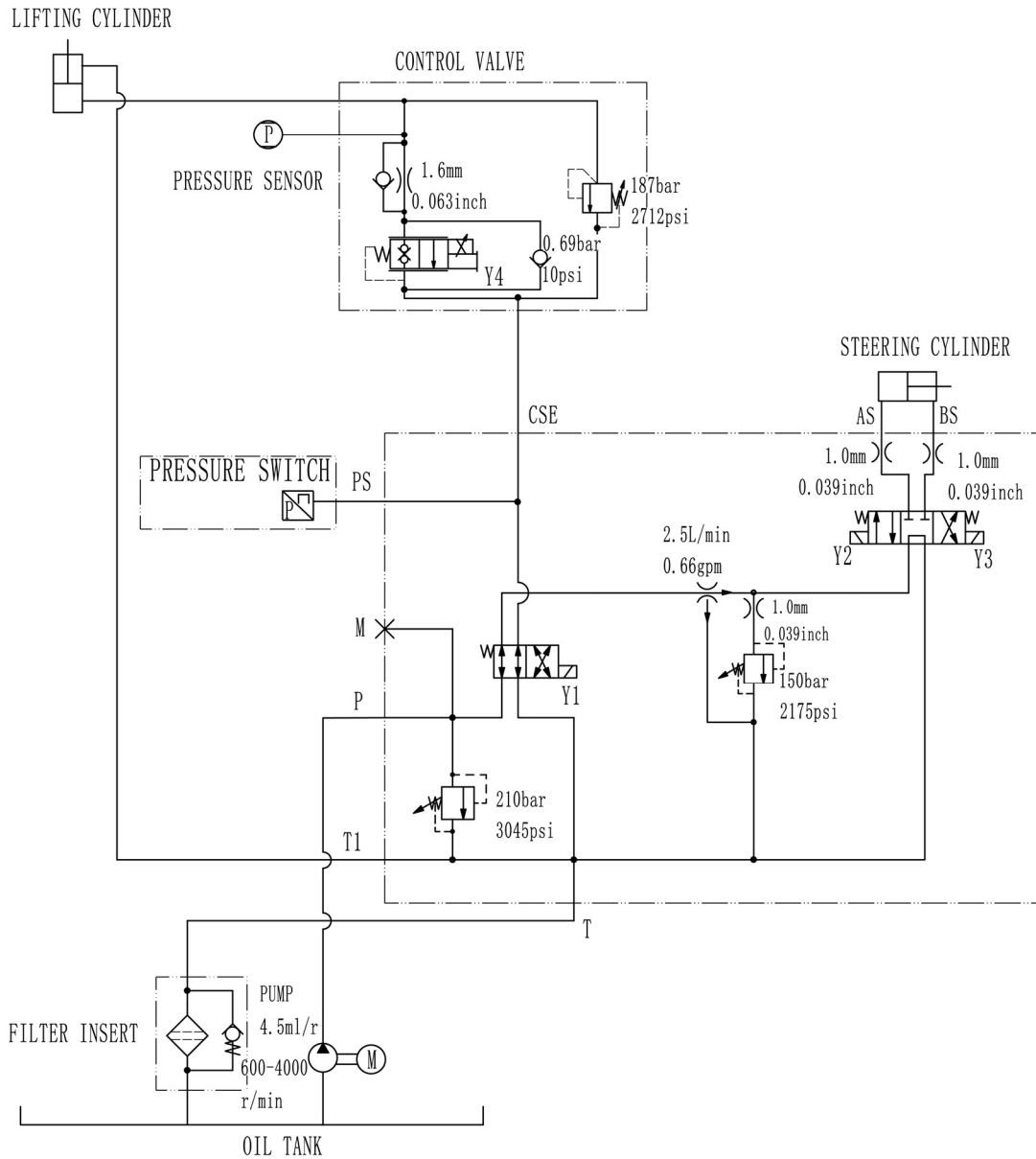

AS2646 HYDRAULIC SCHEMATIC

AS2646 Hydraulic schematic

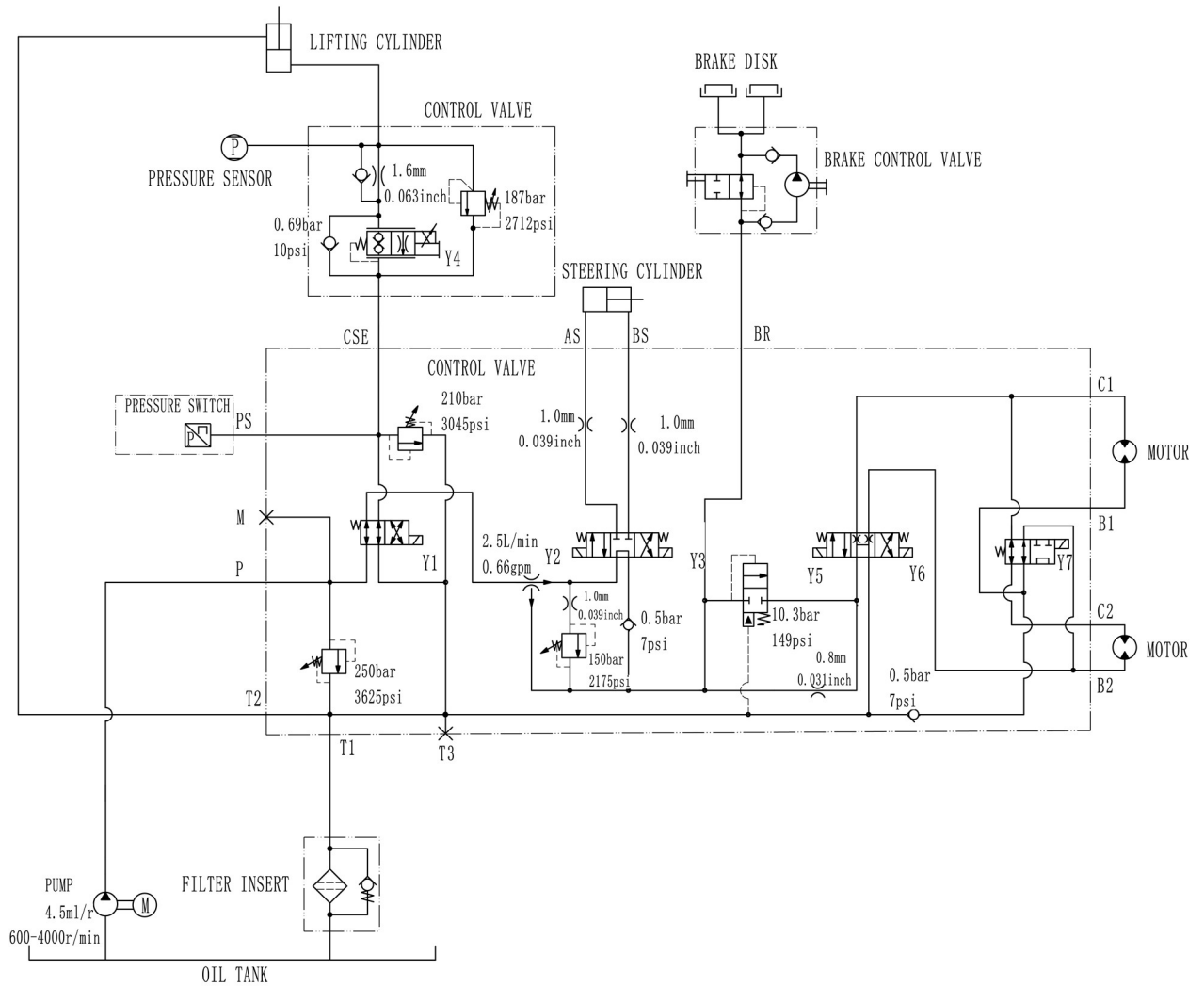

AS3246E HYDRAULIC SCHEMATIC

AS3246E Hydraulic schematic

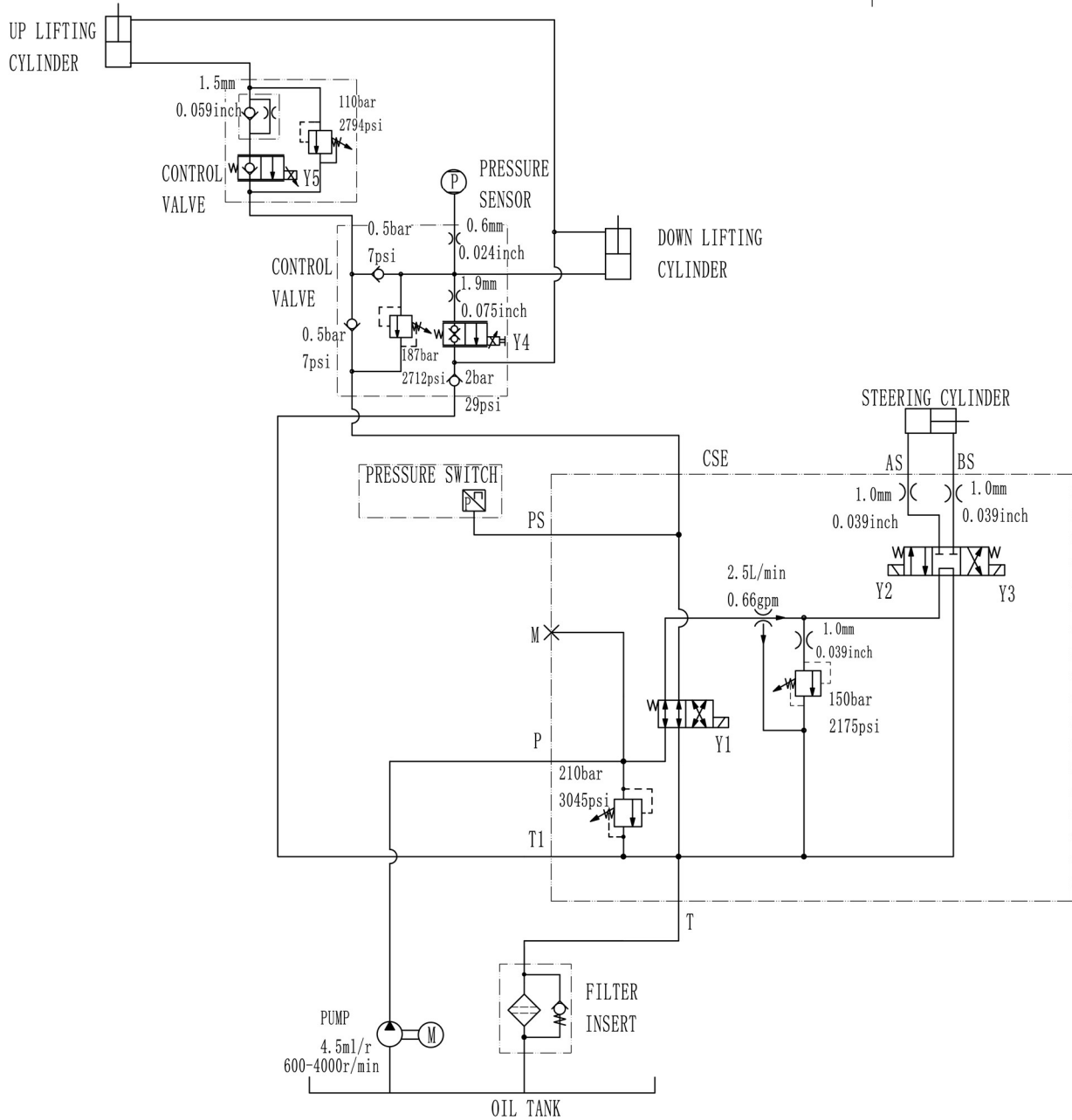

AS3246 HYDRAULIC SCHEMATIC

AS3246 Hydraulic schematic

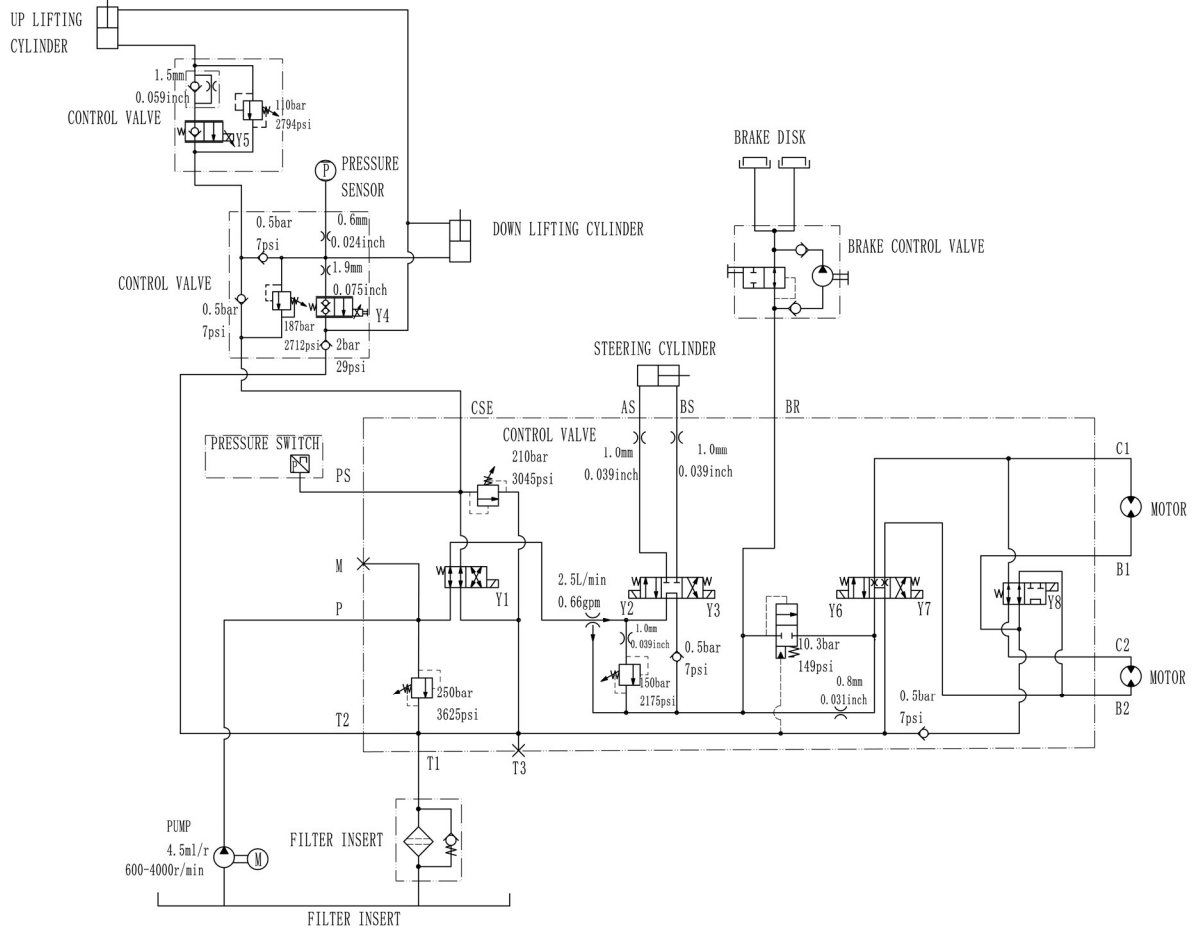

AS4046E HYDRAULIC SCHEMATIC

AS4046E Hydraulic schematic

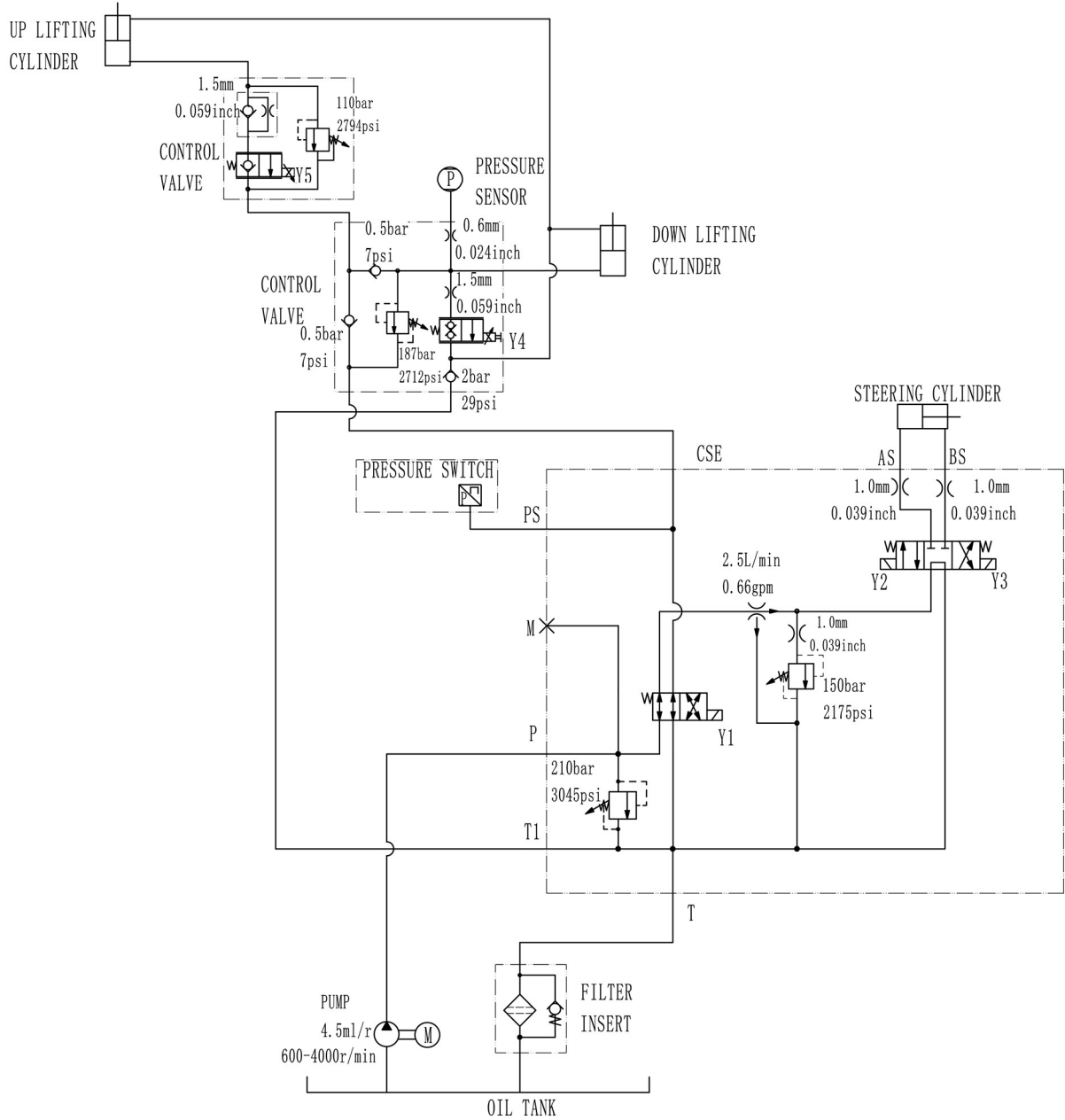

AS4046 HYDRAULIC SCHEMATIC

AS4046 Hydraulic schematic

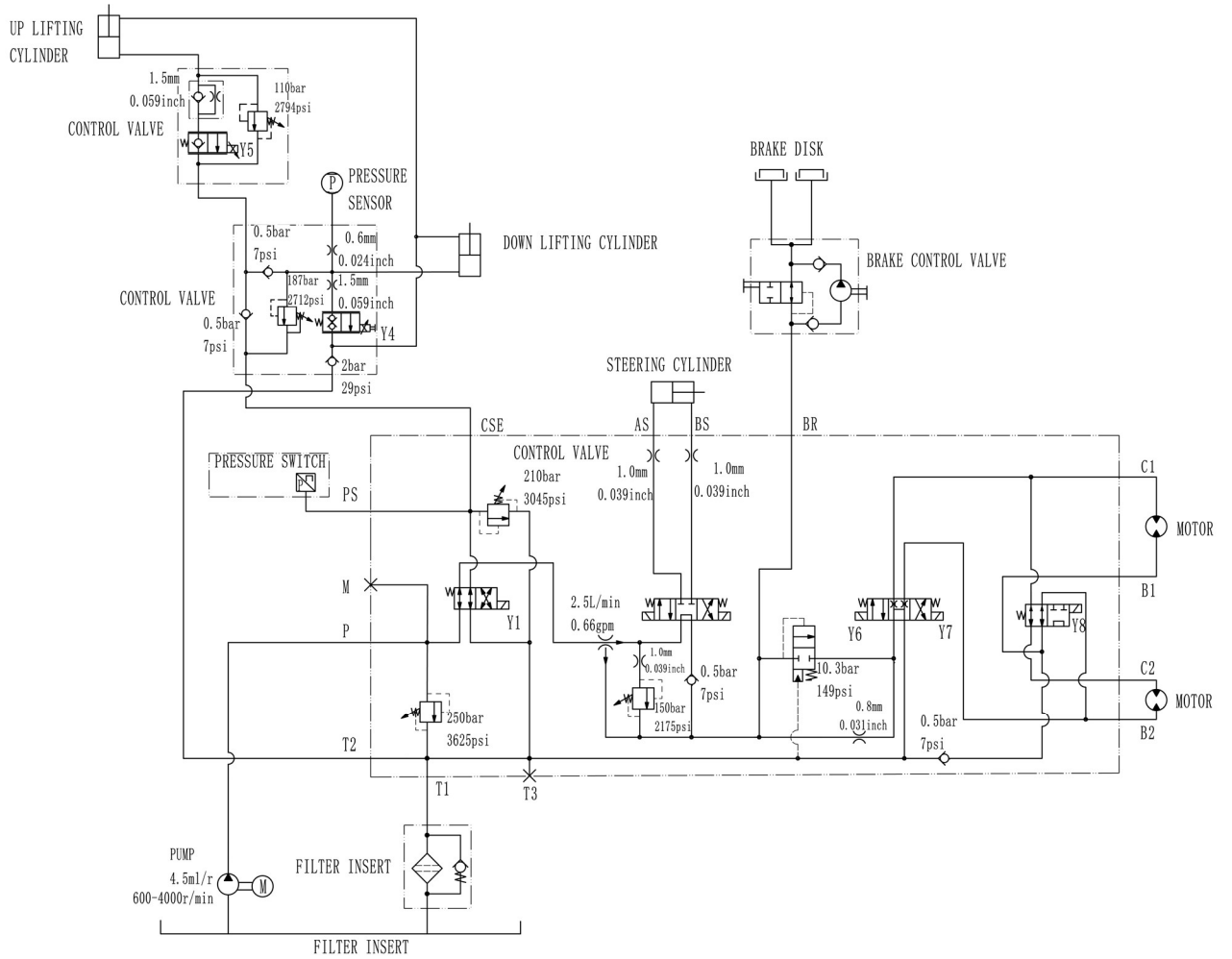

AS4650 HYDRAULIC SCHEMATIC

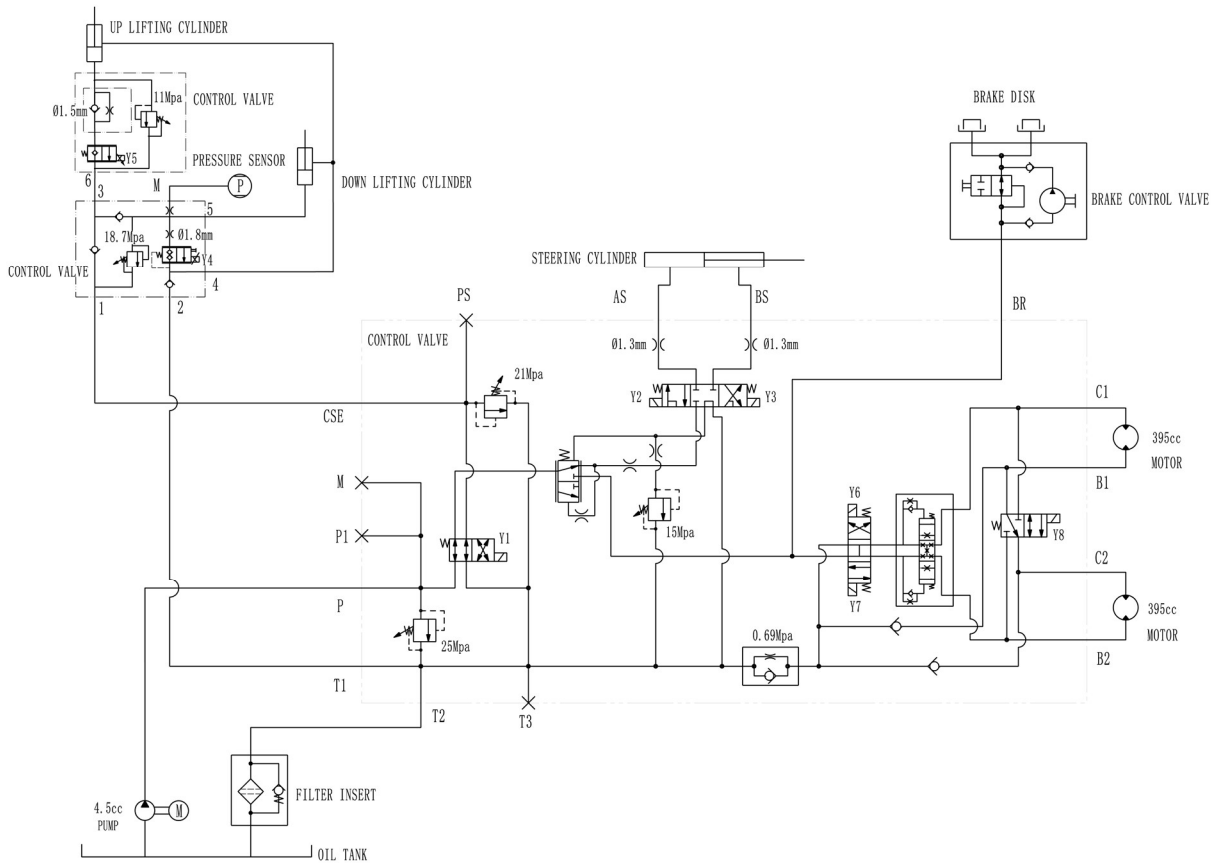

AS4650E HYDRAULIC SCHEMATIC

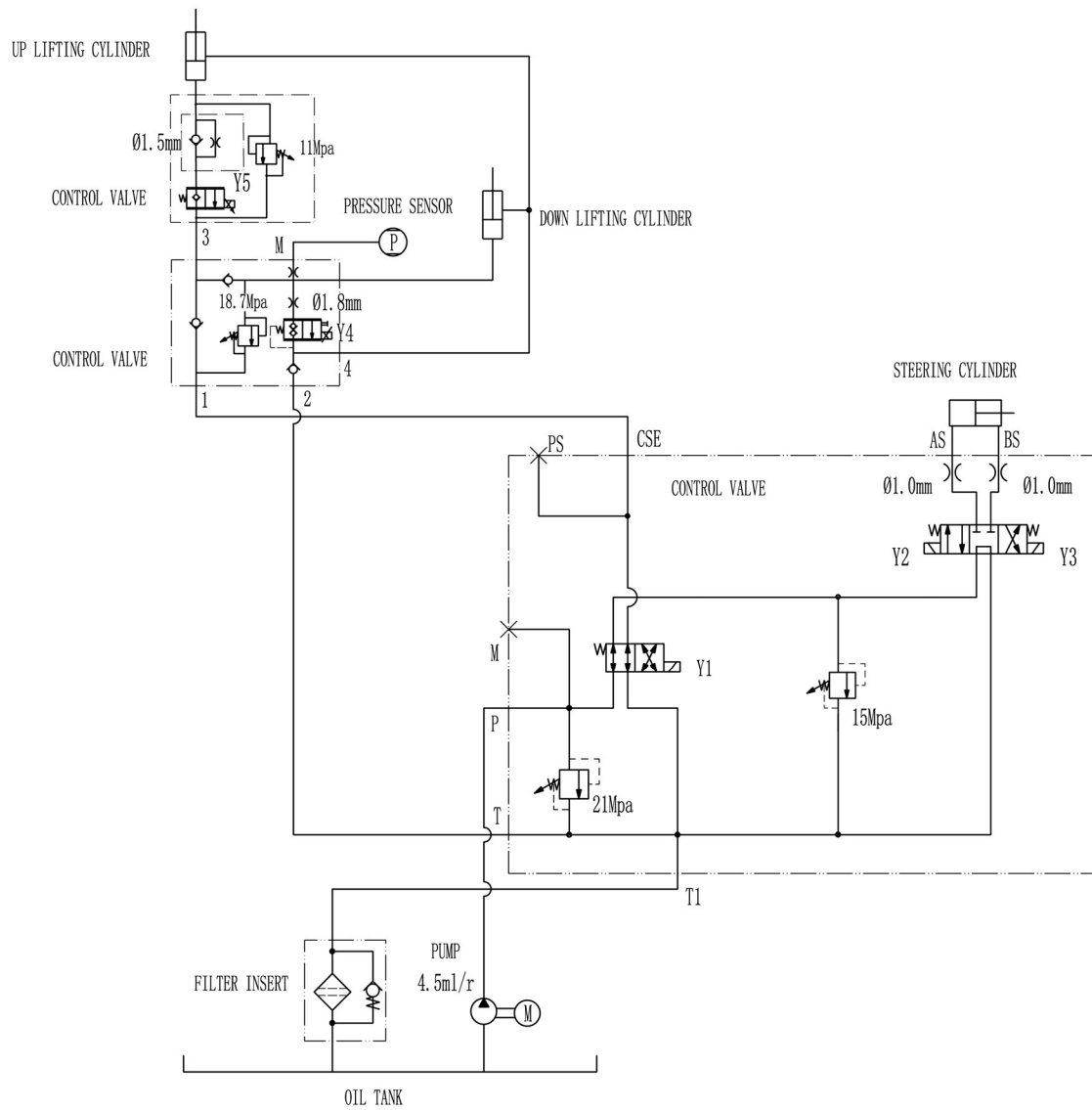

AS1930E/AS1932E/ AS2632E/ AS2646E/ AS3246E/ AS4046E ELECTRIC SCHEMATIC

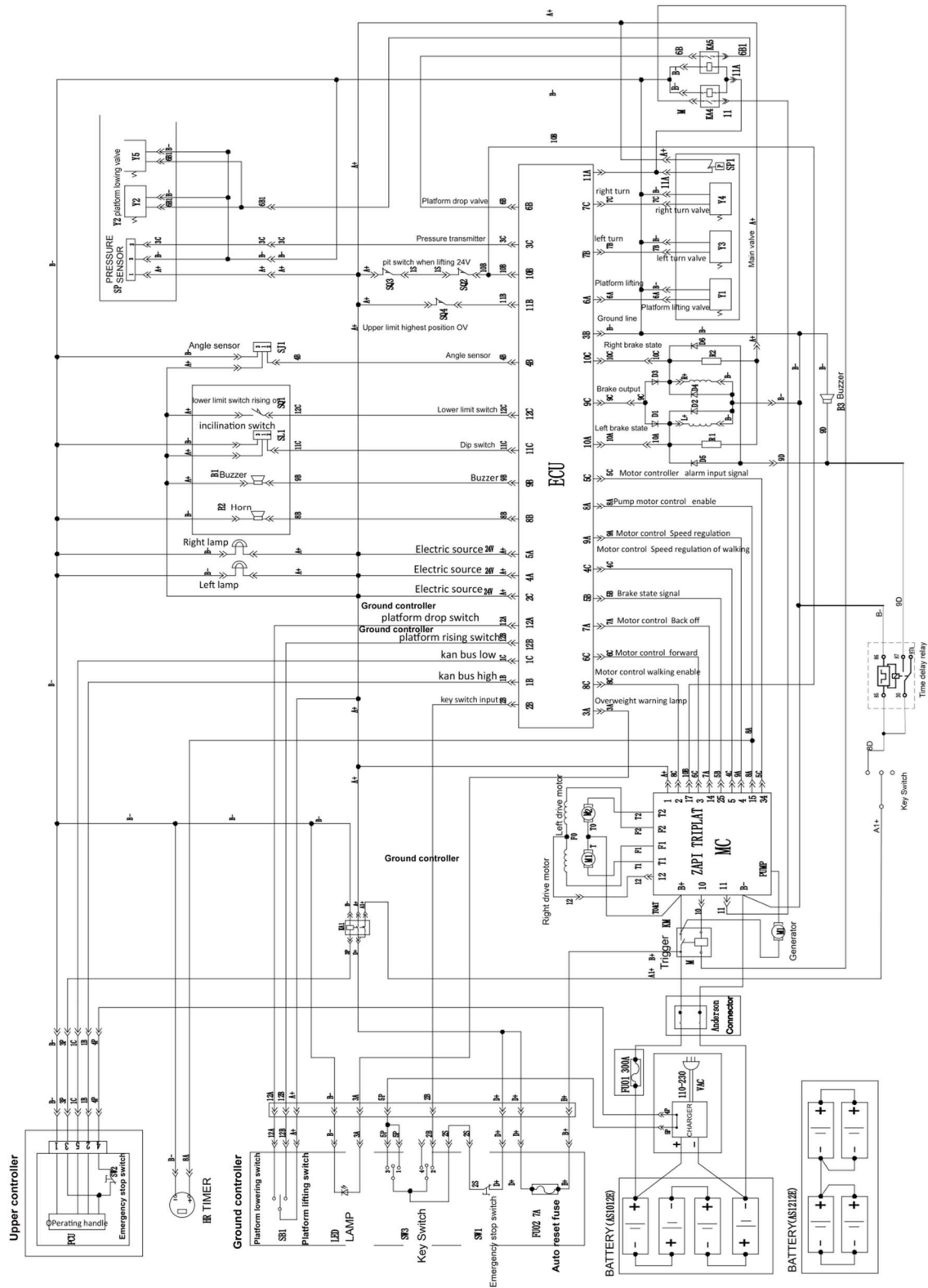

SS1230E/ SS1432E/ SS1932E ELECTRIC SCHEMATIC

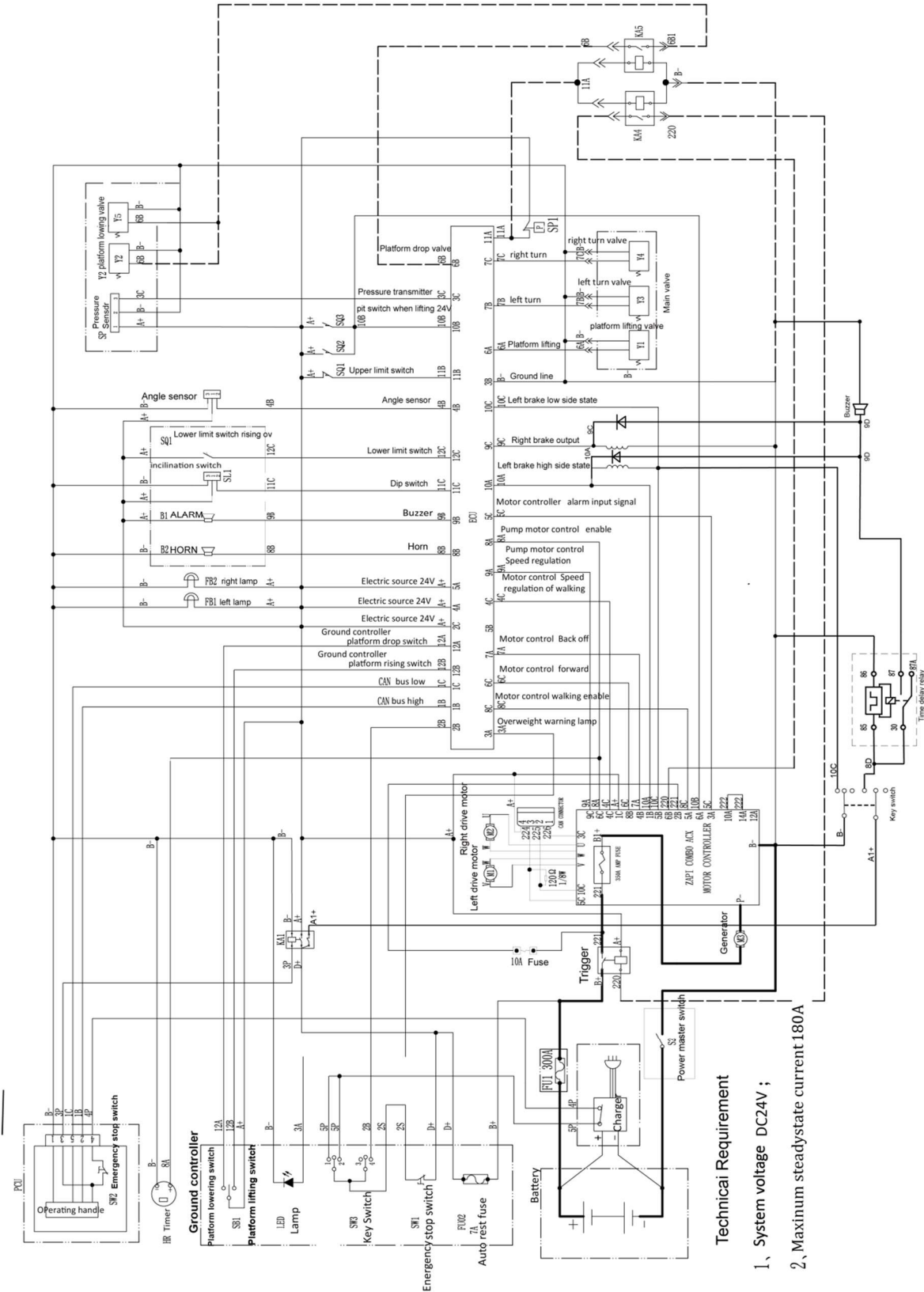

AS1930/AS1932/ AS2632/ AS2646/ AS3246/ AS4046 ELECTRIC SCHEMATIC

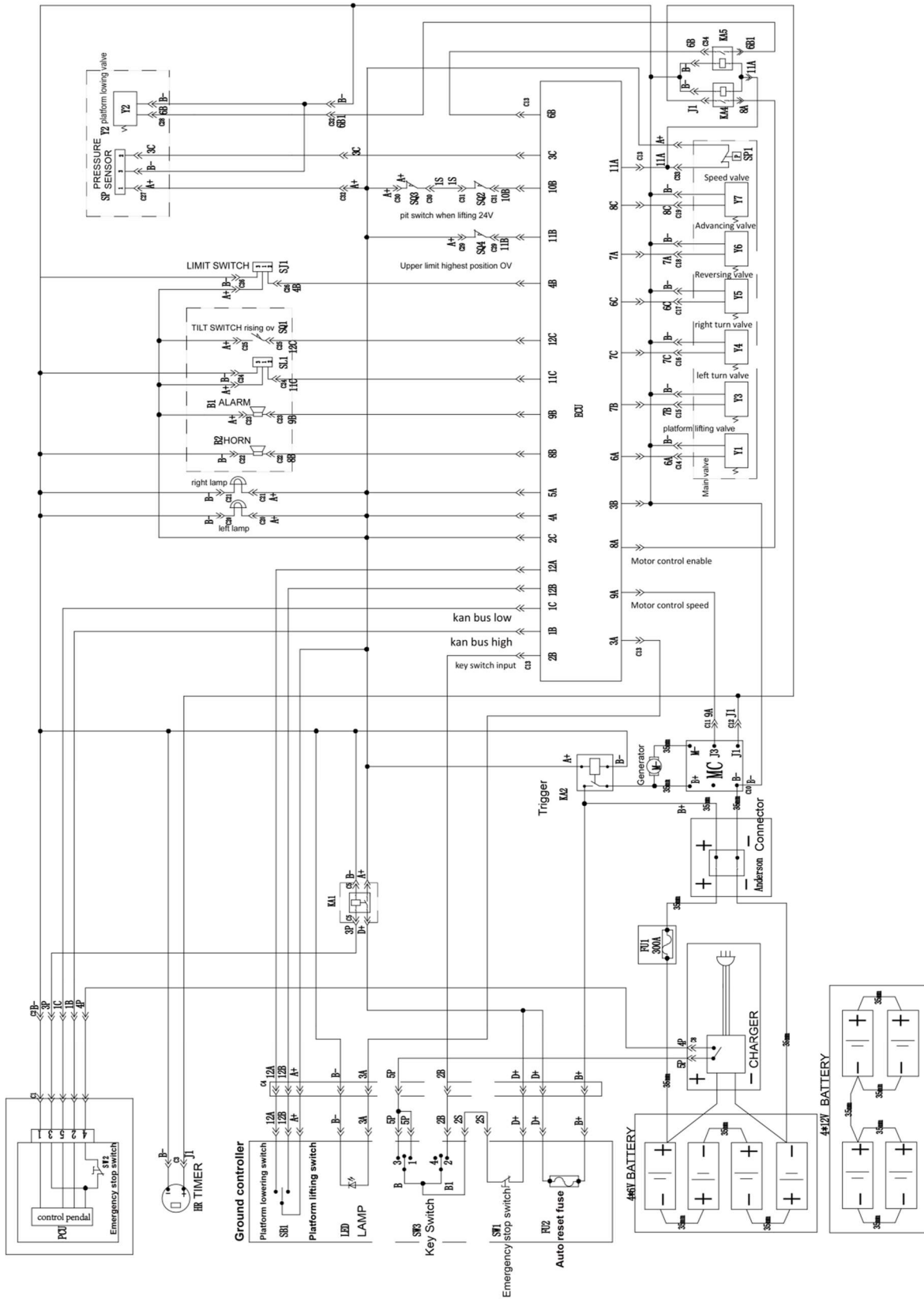

AS4650 ELECTRIC SCHEMATIC

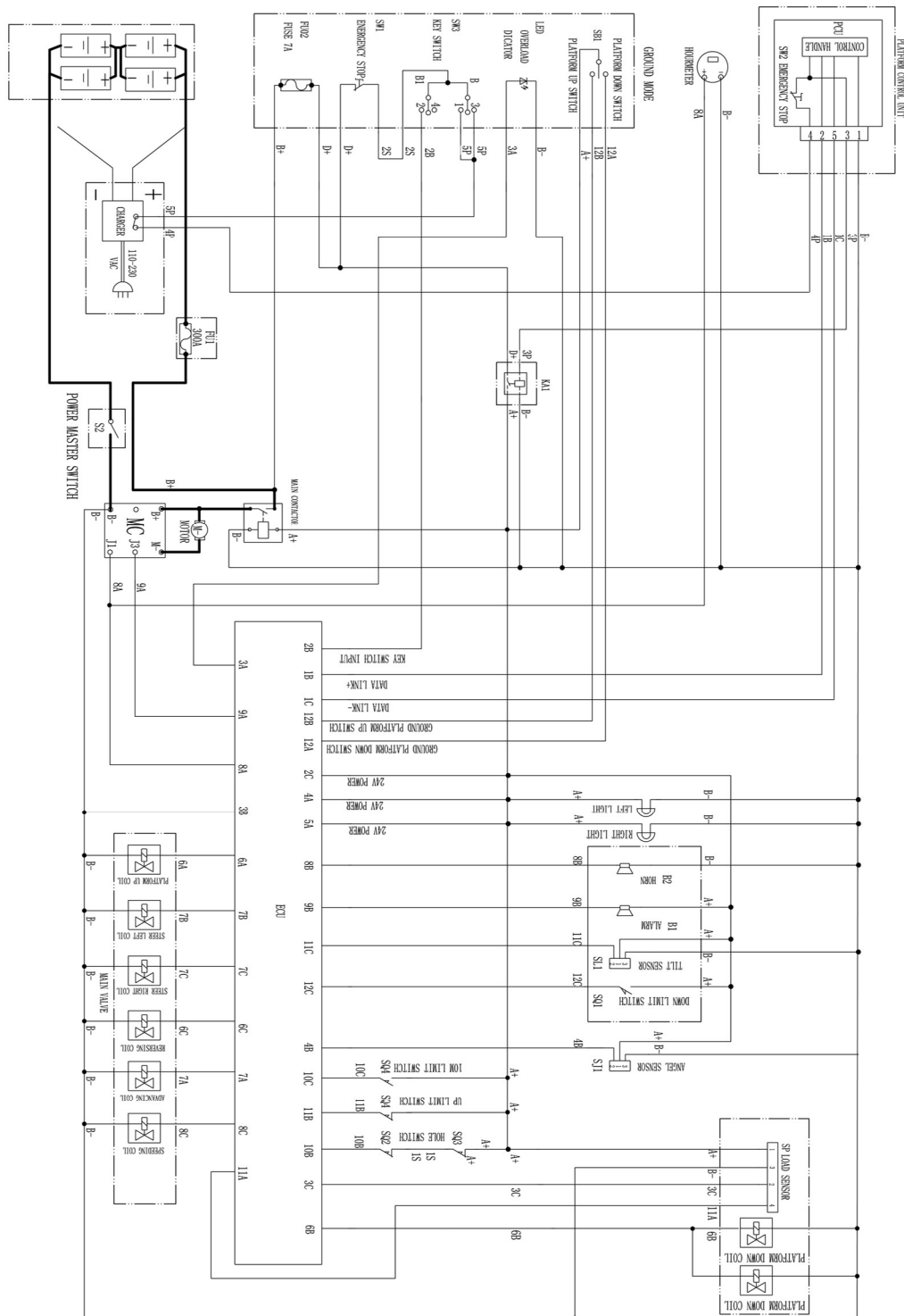

AS4650E ELECTRIC SCHEMATIC

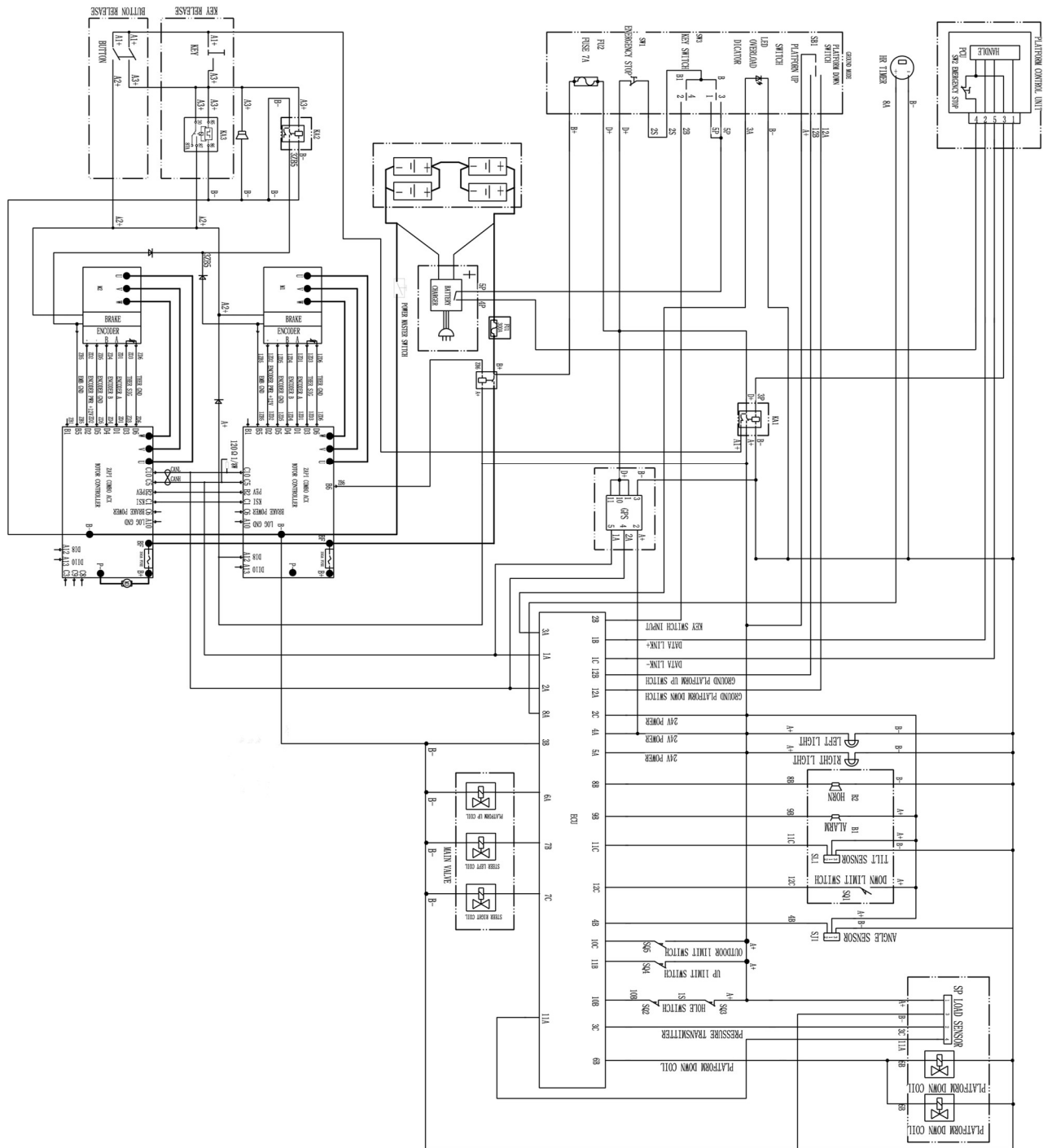



This page left blank intentionally

Mobile Elevating Work Platform Maintenance Manual

First edition – March 2021



LGMG North America Inc.

LGMG North America, Inc.

1445 Sheffler Drive

Chambersburg, PA. 17201

Toll Free: 833.288.LGMG (5464)

Local Phone: 717.889.LGMG (5464)

Email: sales@lmgna.com

www.lmgna.com