

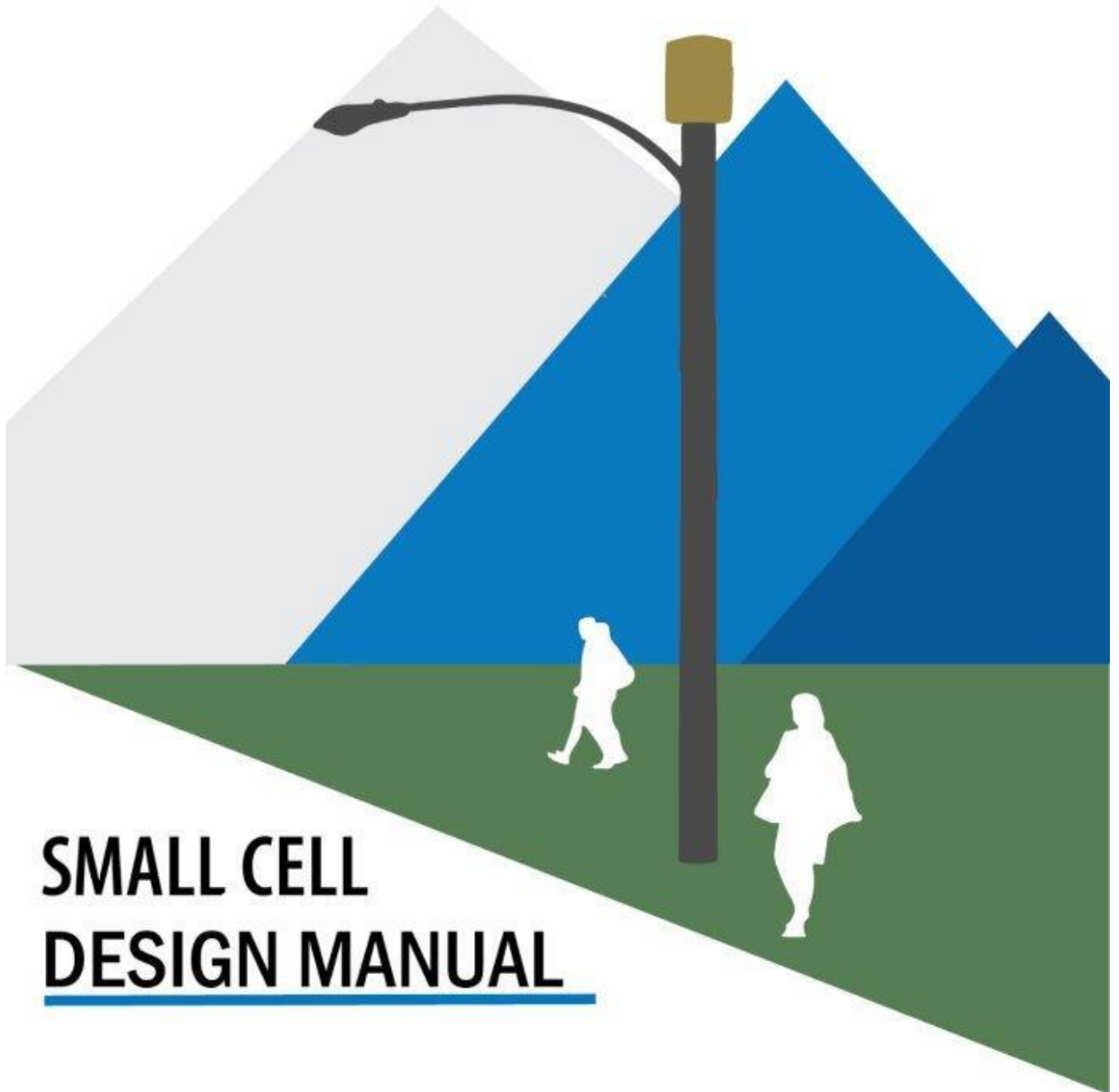

**Lakewood**  
Colorado



# **SMALL CELL DESIGN MANUAL**

---

# INDEX

<b>Background</b> .....	<b>3</b>
<b>Applicability</b> .....	<b>3</b>
<b>Design Considerations</b> .....	<b>4</b>
<b>Types of Small Cell Facilities</b> .....	<b>4</b>
<b>Small Cell Permit Process</b> .....	<b>6</b>
<b>1. Attachments to Wooden Power Poles</b> .....	<b>8</b>
General Guidance.....	8
Design Guidelines.....	8
<b>2. Replacement of Metal Street Light Poles (preferred method)</b> .....	<b>12</b>
General Guidance.....	12
Types of Poles Allowed.....	12
Design Guidelines.....	13
<b>3. Installation of Freestanding Small Cell Pole</b> .....	<b>17</b>
General Guidance.....	17
Types of Poles Allowed.....	125
Design Guidelines.....	176
<b>4. Accessory Equipment and Placement Requirements</b> .....	<b>19</b>
Placement Requirements.....	19
Accessory Equipment .....	20
<b>Definitions</b> .....	<b>21</b>

## BACKGROUND

Small cell facilities are low-powered antennas and related equipment installed by wireless communication providers, such as cell phone service providers, to deploy and improve personal wireless services to generally smaller geographic areas. Small cell facilities will initially provide 4G (LTE) voice and data service and will be modified with future 5G higher speed antennas and antenna equipment as technology changes.

### Applicability

This *Small Cell Design Manual* is intended to provide an overview of the permit process, provide direction to preserve the aesthetic character of the community and ensure placement of poles and equipment does not create a safety hazard. Federal and state law

requires cities to allow small cell facilities in the public right-of-way (ROW), which includes streets and sidewalks. The city of Lakewood recognizes that installing utility facilities in the public ROW is allowed; however, the city shall not be liable to owners or users of small cell facilities for any damage caused by those persons or entities.

All small cell facilities and associated accessory equipment shall meet the current standards and regulations of the Federal Aviation Administration (“FAA”), Federal Communications Commission (“FCC”), and any other agency of the federal or state government with the authority to regulate wireless services and equipment.

Deviations from this guide shall be reviewed on a case-by-case basis by the city of Lakewood and may be granted if these standards would result in a prohibition or effective prohibition of personal wireless service. The city may also permit a deviation from these standards when it finds the applicant’s proposed design provides equivalent or superior aesthetic value when compared to strict compliance with these standards.



Photo Courtesy: City of Fullerton

## **Design Standards**

Small cell facilities shall be designed and located to minimize the impact on the surrounding neighborhood and to maintain the character and appearance of the city. Applicants installing small cell facilities are highly encouraged to replace existing street lights with a dual-use (combination of small cell and street lighting) pole. The location of new dual-use or freestanding poles shall be done in a manner that minimizes impact to view corridors.

Wireless communication providers shall consider the aesthetics of the existing street lights and neighborhoods adjacent to proposed small cell locations prior to submitting an application to the city. When a small cell facility is installed in a neighborhood with unique street light characteristics, the design shall closely match the existing street light aesthetics. Unique assemblies may include mast arms, decorative pole bases, architectural luminaires, mounting heights, pole colors, etc., that deviate from these guidelines.

New small cell facilities must use camouflage design techniques that blend the facility with the natural and built environment. Lakewood has designated different colors by area of the city. In most areas, brown is the predominate color and is also used to replace galvanized street light poles. Districts subject to architectural design standards, such as Belmar and Denver West, use silver and other districts use black or green. Typically, the new or replacement pole color will be the same as the existing or adjacent street light poles. To verify the pole location, type, height, color, and fixture or to receive a Statement of No Objection (SONO) for XCEL please contact the city's Transportation Engineering Division [smallcell@lakewood.org](mailto:smallcell@lakewood.org) or (303-987-7980).

## **Types of Small Cell Wireless Facilities**

Lakewood has identified three different types of small cell installations that are permitted in the rights-of-way (Figure 1). These types include attachments to existing wooden power poles, replacement of existing metal street light poles (preferred method), and new freestanding metal pole installations. An overview of each type is shown in Sections 1 through 3 of this design manual. We are currently researching strand mounted requirements and they will be included in a future update. Please contact us if you currently have a location where strand mounting may be a better solution and we can discuss the case.

Figure 1: Types of Small Cell Facilities

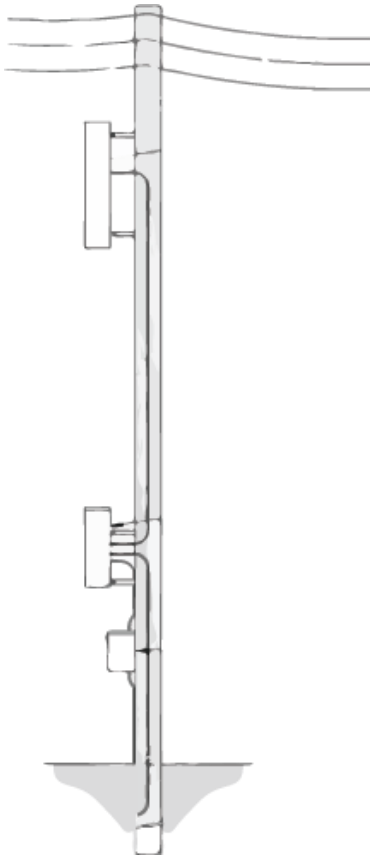

1 Attached to Wooden Pole



2 Replacement of Street Lights

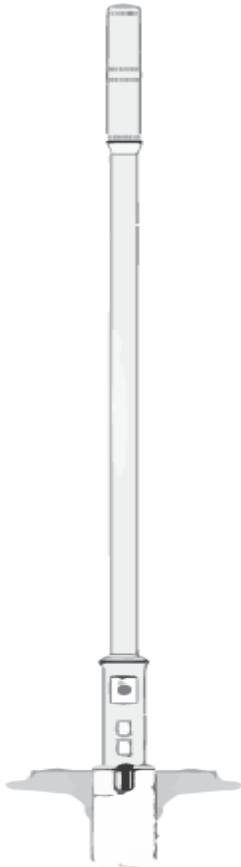

3 New Freestanding Poles

# Small Cell Permit Process

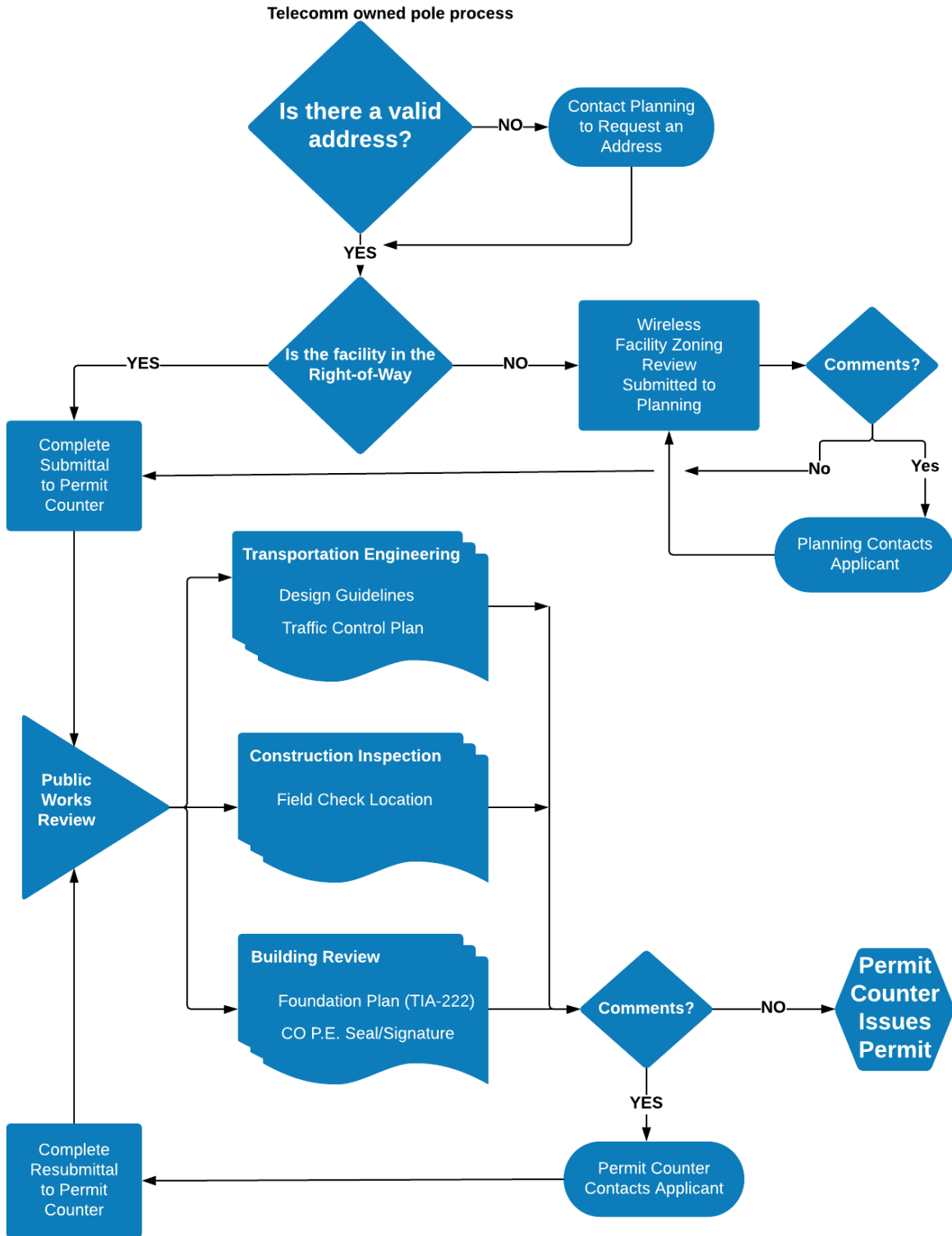

**XCEL dual-use pole replacement process**

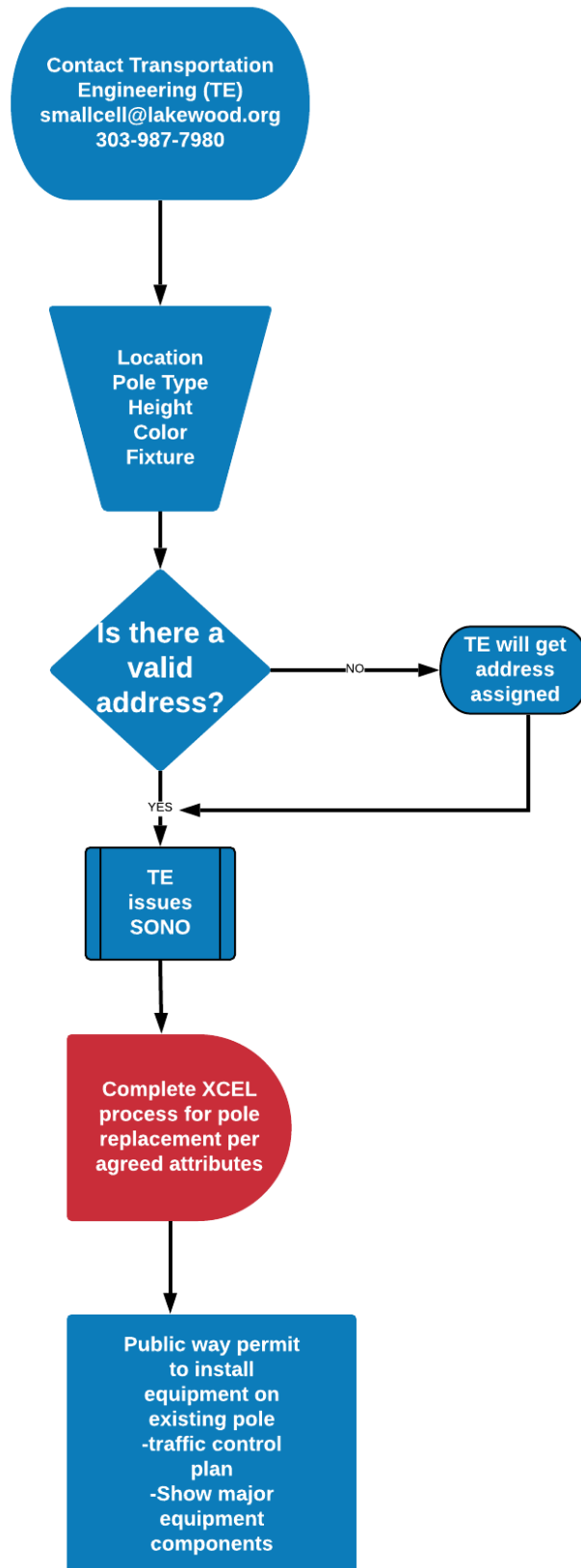

## 1. ATTACHMENTS TO WOODEN POWER POLES

### Overview

Small cell facilities may be deployed in the public right-of-way through the utilization of an existing wooden power or street light pole (Figure 2). They may be replaced with taller wooden poles to facilitate the small cell equipment as necessary, subject to zoning district height restrictions. All attachments to wooden power poles shall be approved by the city and Xcel Energy prior to installation. All equipment shall meet Xcel Energy's utility requirements and the city's Small Cell ROW Permit requirements. All equipment located within the ROW shall be located such that it meets city standards, ADA requirements, and does not obstruct, impede, or hinder usual pedestrian or vehicular travel.



Photo Courtesy: Google Earth

Any existing luminaire shall be upgraded to LED and meet the city's street lighting requirements. The designer can contact the city lighting tech for confirmation of required luminaire at [smallcell@lakewood.org](mailto:smallcell@lakewood.org) or 303-987-7980 with the current luminaire style and wattage.

Small wireless facilities shall also meet all requirements of the applicable Right-of-Way Use Agreement with the city.

Small cell facilities in the rights-of-way shall be removed and relocated at no cost to the city as provided in the city's right-of-way use agreement.

### Design Standards

All small cell carrier antennas and antenna equipment shall be mounted behind a shroud. Antennas that technically cannot be covered by a shroud shall have concealment built up to the antenna edge to create a uniform appearance aesthetically, if they stand off more than 6 inches from the pole face or farther than 6 inches combined from the pole edge extended. The small cell equipment shall be co-located and concealed by up to two shrouds, including the radio cabinet area and antenna area. The Xcel meter service and disconnect do not require shrouding.



The antenna shroud may alternatively be mounted to strand cable on an existing span, please contact the transportation engineering division at [smallcell@lakewood.org](mailto:smallcell@lakewood.org) or 303-987-7980 to review proposed aesthetics. No new overhead cable spans shall be created for the sole purpose of the small cell facility.

Figure 2: Small Cell Attached to Wooden Pole

---

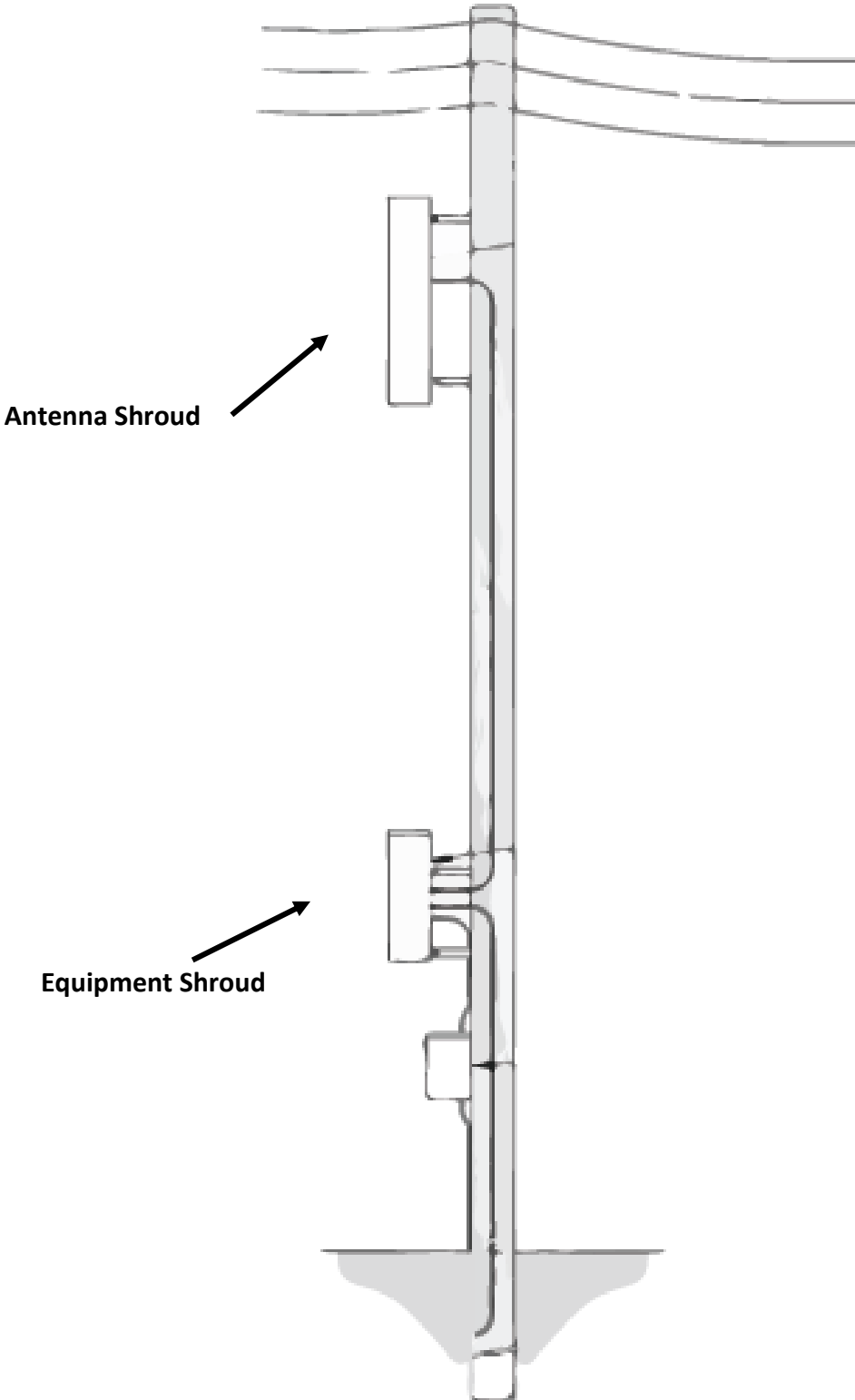

**TABLE 1: SPECIFICATIONS FOR WOOD POLE INSTALLATIONS**

Luminaire	Per Lakewood’s and Xcel’s requirements
Luminaire Mast Arm	Per Xcel Energy’s lighting standards
Luminaire Mounting Height	Same height as surrounding luminaires
Electrical service	Per Xcel Energy’s requirements
Grounding	Per Xcel Energy’s requirements
Separation of Service	All new conduit and cable shall be separated by owner in any pull boxes.
Utility Equipment	Per Xcel Energy’s requirements
Equipment Shroud	49” H x 19” W x 13” D maximum
Cantenna (if provided)	19” diameter x 80” height (maximum)
Antenna - Side mounted (if provided)	16” wide with height and depth not to exceed 9 cubic feet.
RF Equipment Disconnect	Per Xcel Energy’s requirements
Owner Identification	A 4” by 6” (maximum) plate with the carrier’s name, location identifying information, and emergency telephone number shall be permanently affixed to the equipment.
Color	Small cell facility accessory equipment and shrouds shall be colored gray or brown

## 2. REPLACEMENT OF METAL STREET LIGHT POLES (PREFERRED METHOD)

### General Guidance

Existing street light poles may be replaced with the installation of a new dual-use or combination pole (Figure 3). This type of small cell facility is the city of Lakewood's preferred method for supporting small cell deployments.

Existing street lights are typically owned by Xcel Energy; however, the city of Lakewood owns several hundred street light poles around the city that should be considered first for conversion to company owned dual-use poles. Xcel Energy owned dual-use poles that replace existing street lights shall meet Xcel Energy's standards and Lakewood's requirements. Dual-use poles shall be reviewed via the city of Lakewood's Small Cell ROW Permit requirements. For company owned poles, to simplify and reduce construction costs, the luminaire on company owned poles will be powered by the same service as the small cell facility. Maintenance and power will be the responsibility of the pole owner. For Xcel

Energy owned dual-use poles, the luminaire will be flat rated (billed to the City of Lakewood) and the small cell facility will be metered per Xcel Energy requirements. Xcel will continue to provide maintenance to the luminaire per tariff and franchise requirements.

Any existing luminaire shall be upgraded to LED and meet the city's street lighting requirements. The designer can contact the city lighting tech for confirmation of required luminaire at [smallcell@lakewood.org](mailto:smallcell@lakewood.org) or 303-987-7980 with the current luminaire style and wattage.

### Types of Poles Allowed

There are two main types of replacement street light poles. The first type (2.1) conceals all small cell carrier antennas and equipment internally to the pole and antenna, behind a shroud or concealment. No separate ground level equipment shelters, cabinets or electrical panels shall be installed at each location unless all reasonable alternative pole locations and



Photo Courtesy: Raygan Group

underground locations have been explored and found by the city to be substantially lacking or technically infeasible. This type 2.1 pole is expected in most areas of the city.

The second type (2.2) is a dual-use pole (equipment cabinets) and will be allowed when the proposed area has adequate right-of-way width to safely house and conceal the associated equipment cabinet and power meter cabinet or on high speed roadways requiring breakaway features. To qualify for this installation, the applicant must demonstrate that the equipment cabinet is located at least 20' from curb or 3' behind a sidewalk and next to a fence or sound wall that is at least 2' taller than the proposed cabinet. This dual-use pole (equipment cabinets) is expected to mainly be used on arterials where the roadway is separated from adjacent properties with fences or sound walls. It may be permitted in areas with extensive street furniture or areas where visual concealment is less necessary (drainage gulches, area adjacent to natural open spaces, etc.) in the City of Lakewood's determination on a case by case basis.

### **Design Standards**

All small cell facilities and accessory equipment shall meet Xcel Energy's utility requirements (as applicable) and Lakewood's aesthetic design requirements.

Dual-use small cell and street light applications and aesthetics must be approved by the city prior to installation. All new dual-use poles shall match or be substantially similar to the finishes, designs, colors, and other aesthetic characteristics already present in the existing poles or designated for the area.

All antennas and wiring shall be concealed within the vertical pole, within a cantenna, or behind a shroud mounted to the top of the pole structure. All cantennas and shrouds shall provide as complete concealment as possible to ensure concealed views of antennas, equipment, and other hardware. Antennas that technically cannot be covered by a shroud shall have concealment built up to the antenna edge to create a uniform appearance aesthetically, if they stand off more than 6 inches from the pole face or farther than 6 inches combined from the pole edge extended.

Type 2.1 poles shall have all equipment, meters, and wiring mounted internally. The antennas shall be concealed utilizing a cantenna, shrouding or similar camouflage design acceptable to the city. It is recognized that some installations may use a distributed power cabinet for multiple pole locations, eliminating the need for a meter and service at each pole location.

Type 2.2 poles shall have separate equipment cabinets and meters. The equipment cabinets shall use camouflage design techniques, including the use of materials, colors, screening, undergrounding, or other design options that will blend into the surrounding natural setting. Wherever possible, new small cell equipment cabinets shall utilize existing landforms, vegetation, and structure to aid in screening the facility from view and to blend in with surrounding built and natural environment and maintain a cohesive appearance.

Type 2.1 and 2.2 poles may have one separate 3 cubic foot equipment shroud or similar camouflage design acceptable to the city covering externally mounted equipment in addition to the antenna. To qualify for this installation, the applicant must demonstrate that the additional technology cannot be integrated into the equipment cabinet and/or the antenna or there are multiple carriers co-locating on the pole.

Figure 3: Type 2.1 and 2.2 Dual-Use Poles

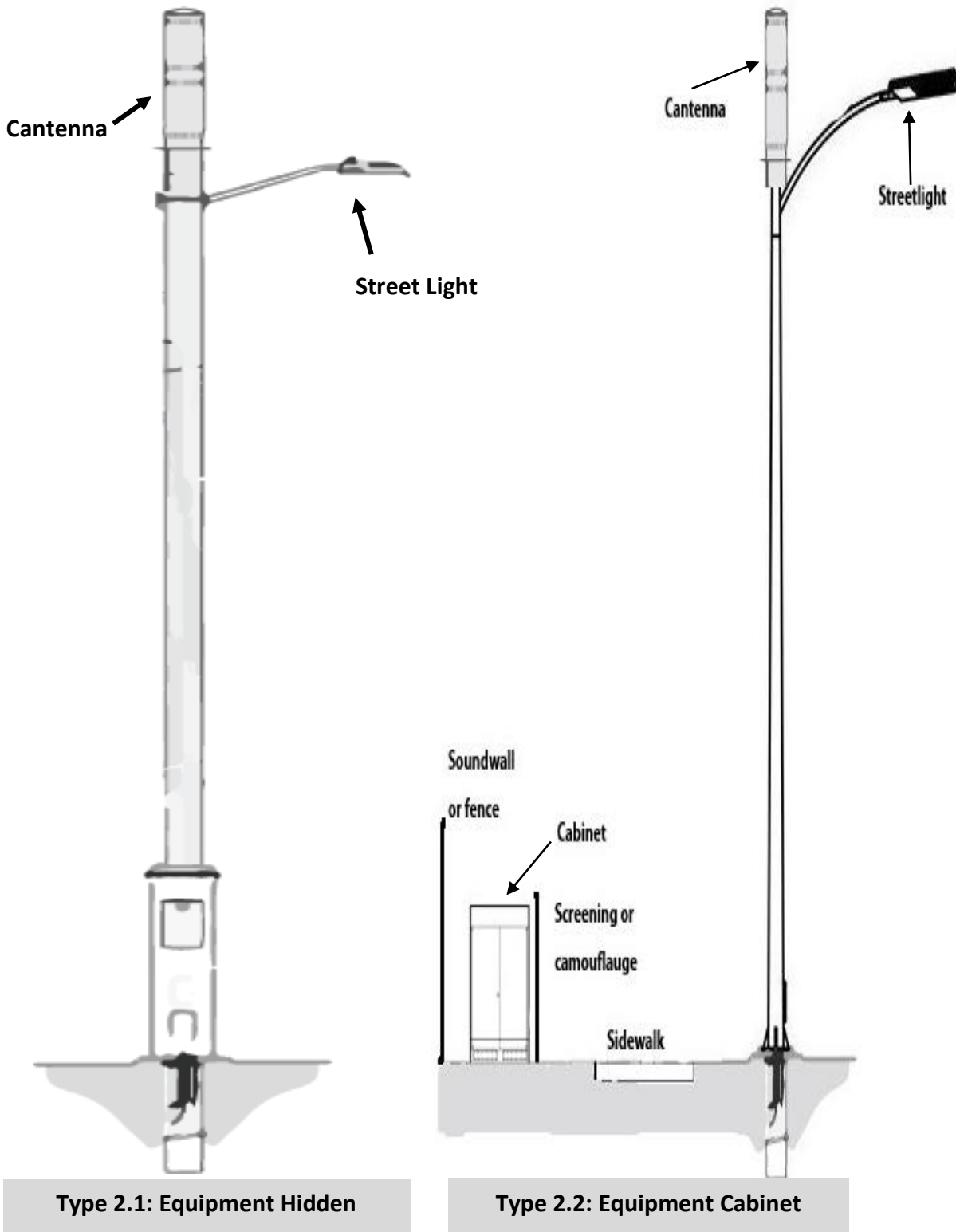

**TABLE 2: SPECIFICATIONS FOR DUAL-USE POLE INSTALLATIONS**

Pole Type	Round, straight, galvanized steel.
Pole Color	If the pole is painted to match existing street light aesthetics, paint shall be powder coated over zinc paint. Pole and equipment cabinet shall still be galvanized.
Pole Design Parameters	TIA-222 rev H including any updates or addendums. Include changes for local condition: 130 mph special wind zone for poles under 45' tall.
Equipment Cabinet Dimensions	20" diameter x 5'-8" tall (maximum)
Access Doors	Utility access- Per Xcel Energy requirements, meter shall be recessed as much as possible into the equipment cabinet. Luminaire access- hand hole with fused power disconnect. Carrier access- Lockable door appropriately sized.
Luminaire	Per Lakewood requirements
Luminaire Mast Arm	To match adjacent luminaire arms
Luminaire Mounting Height and Pole Height	Luminaires at same height as surrounding luminaires. Structure height may not exceed 40' or 8' taller than any existing utility or traffic signal pole within a radius of 600' within the same zone district and on the same category of street
Electrical Service	Per Xcel Energy's requirements
Separation of Service	All new conduit and cable shall be separated by owner in any pull boxes.
Ventilation	Passive louvers and/or passive ventilation systems are preferred. If required, fans shall not emit noise greater than 50 dBs at one meter (3.28').
Antenna (if provided)	19" diameter x 80" height (maximum)
Side mounted Shroud (if allowed)	16" wide with height and depth not to exceed 9 cubic feet.
Equipment Cabinet Area (if allowed)	350 SF maximum size. Camouflaging and any associated wall or fence shall be lower than adjacent existing sound wall or fence.
Owner Identification	A 4" by 6" (maximum) plate with the carrier's name, location identifying information, and emergency telephone number shall be permanently affixed to the equipment.
Color	Antennas and small cell facility accessory equipment shall be colored gray, black or pole color.



### 3. INSTALLATION OF FREESTANDING SMALL CELL POLE

#### General Guidance

Freestanding small cell poles are standalone structures located in the ROW (Figure 4). The use of freestanding small cell poles shall be the last option considered for a location.

#### Types of Poles Allowed

There are two main types with some minor variations for freestanding small cell poles.

The first type (3.1) conceals all small cell carrier antennas and equipment internally to the pole and cantenna, behind a shroud or concealment.

No separate ground level equipment shelters, cabinets or electrical panels shall be installed at each location unless all reasonable alternative pole locations and underground locations have been explored and found substantially lacking. This type of pole is rarely expected in most areas of the city as most situations will require a type 2.1 dual-use pole.

The second type (3.2) is a pole with separate equipment cabinets and will be allowed when the proposed area has adequate right-of-way width to safely house and conceal the associated equipment cabinet and power meter cabinet or on a high speed roadway requiring breakaway features and a type 2.2 pole is technically infeasible. To qualify for this installation, the applicant must demonstrate that the equipment cabinet is located at least 20' from curb or 3' behind a sidewalk and next to a six-foot or taller fence or sound wall and that there is not an existing street light that can be replaced. This dual-use pole (equipment cabinets) is expected to mainly be used on arterials where the roadway is separated from adjacent properties with fences or sound walls without street lights. It may be permitted in areas with extensive street furniture or areas where visual concealment is less necessary (drainage gulches, adjacent to natural open spaces, etc.) by the city of Lakewood's determination on a case by case basis.



Photo Courtesy: City of Lakewood

## Design Standards

All small cell facilities and accessory equipment shall meet Xcel Energy’s utility requirements (as applicable) and Lakewood’s design aesthetics.

Freestanding small cell applications and aesthetics must be approved by Lakewood prior to installation. All new freestanding poles shall match or be substantially similar to the finishes, designs, colors, and other aesthetic characteristics already present in the existing poles or designated for the area.

All antennas and wiring shall be concealed within the vertical pole, within a cantenna, or behind a shroud mounted to the top of the pole structure. All antennas and shrouds shall provide as complete concealment as possible to ensure concealed views of antennas, equipment, and other hardware. Antennas that technically cannot be covered by a shroud shall have concealment built up to the antenna edge to create a uniform appearance aesthetically, if they stand off more than 6 inches from the pole face or farther than 6 inches combined from the pole edge extended.



Example shrouding for uncovered panels.

All Type 3 freestanding small cell poles shall be separated by at least 600 feet from another freestanding Type 3 Small Cell Pole, and shall meet all applicable requirements of Section 4 regarding placement.

Type 3.1 poles shall have all equipment, meters, and wiring mounted internally. The antennas shall utilize a cantenna, shroud or similar camouflage design acceptable to the city.

Type 3.2 poles shall have separate equipment cabinets and meters. The equipment cabinets shall use camouflage design techniques, including the use of materials, colors, screening, undergrounding, or other design options that will blend into the surrounding natural setting. Wherever possible, new small cell equipment cabinets shall utilize existing landforms, vegetation, and structure to aid in screening the facility from view and to blend in with surrounding built and natural environment and maintain a cohesive appearance.

Type 3.1 and 3.2 poles may have one separate 3 cubic foot equipment shroud or similar camouflage design acceptable to the city covering externally mounted equipment in addition to the cantenna. To qualify for this installation, the applicant must demonstrate that the additional technology cannot be integrated into the equipment cabinet and/or the cantenna or there are multiple carriers co-locating on the pole.

Figure 4: New Freestanding Poles

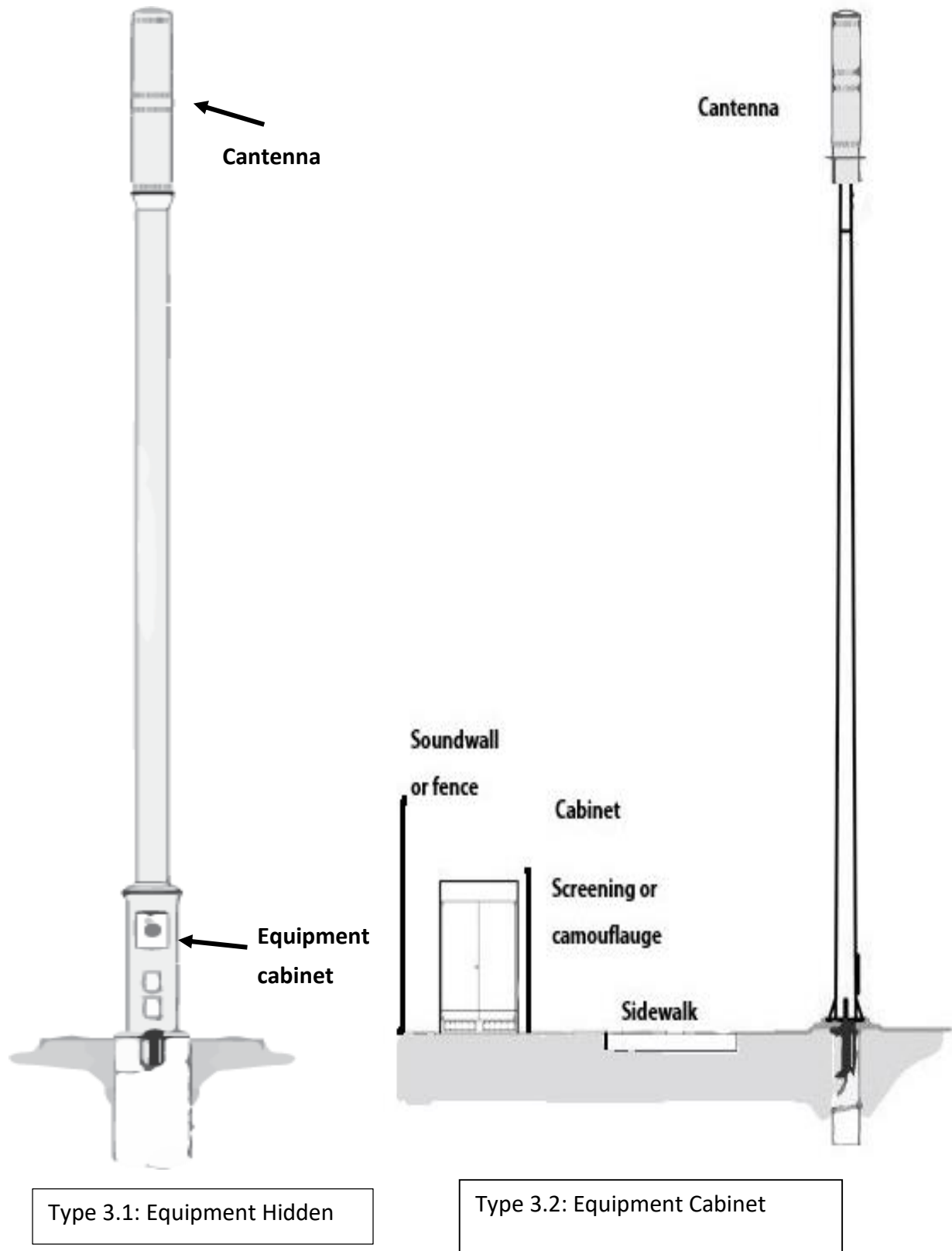

**TABLE 3: SPECIFICATIONS FOR FREESTANDING POLE INSTALLATIONS**

Pole Type	Round, straight, galvanized steel.
Pole Color	If the pole is painted to match existing street light aesthetics, paint shall be powder coated over zinc paint. Pole and equipment cabinet shall still be galvanized.
Pole Design Parameters	TIA-222 rev H including any updates or addendums. Include changes for local condition: 130 mph special wind zone for poles under 45' tall.
Equipment Cabinet Dimensions	20" diameter x 5'-8" tall (maximum)
Access Doors	Utility access- Per Xcel Energy requirements, meter shall be recessed as much as possible into the equipment cabinet. Luminaire access- hand hole with fused power disconnect. Carrier access- Lockable door appropriately sized.
Pole Height	Structure height may not exceed the lesser of 40' or 8' taller than any existing utility or traffic signal pole within a radius of 600' in the same zone district and on the same category of street.
Electrical Service	Per Xcel Energy's requirements
Separation of Service	All new conduit and cable shall be separated by owner in any pull boxes.
Pole Separation	All Type 3 freestanding small cell poles shall be separated by at least 600 feet from another freestanding Type 3 Small Cell Pole, and shall meet all applicable requirements of Section 4 regarding placement.
Ventilation	Passive louvers and/or passive ventilation systems are preferred. If required, fans shall not emit noise greater than 50 dBs at one meter (3.28').
Cantenna (if provided)	19" diameter x 80" height (maximum) colored to match or be substantially similar to pole
Side-mounted Shroud (if allowed)	16" wide with height and depth not to exceed 9 cubic feet.
Equipment Cabinet Area (if allowed)	350 SF maximum size. Camouflaging and any associated wall or fence shall be lower than adjacent existing sound wall or fence.
Owner Identification	A 4" by 6" (maximum) plate with the carrier's name, location identifying information, and emergency telephone number shall be permanently affixed to the equipment.
Color	Small wireless equipment shall be colored gray, black or pole color. Antenna equipment shrouds shall be colored to match pole color.

## 4. ACCESSORY EQUIPMENT AND PLACEMENT REQUIREMENTS

### Placement Requirements

A dual-use small wireless facility and street light pole shall only be located where an existing street light pole can be removed and replaced or at a new location where it has been identified that a street light is necessary.

The location of all new small wireless poles or equipment cabinets, regardless of type, shall be subject to the following:

- Does not alter vehicular circulation or parking within the ROW
- Does not impede vehicular, bicycle, or pedestrian access or visibility along the ROW
- Located a minimum of 15 feet from existing street light, traffic signal or utility poles
- In general alignment with existing trees, utility poles, or street lights
- Equal distance between trees when possible, with a minimum of 15 feet separation such that no proposed disturbance shall occur within the critical root zone of any tree
- With appropriate clearance from existing utilities

When placed adjacent to a residential property, the small cell facility shall be placed in proximity to a common property line between adjoining residential properties, such that it minimizes visual impacts equitably among adjacent and nearby properties (Figure 5). When placed adjacent to a residential property located on a corner lot, the small cell facility shall be placed adjacent to a common property line between adjoining residential properties or on the corner formed by two intersecting streets (Figure 5).

If these placement requirements are not technically feasible, the applicant may submit a written statement to the Public Works Department requesting the small cell facility be exempt from these requirements and offer alternative locations reasonably meeting the intent of these standards and minimizing impacts among residential properties.

Replacement poles and new poles shall comply with the Americans with Disabilities Act, city construction and sidewalk clearance standards, city ordinances, and state and federal laws and regulations in order to provide a clear and safe passage within the rights-of-way.

Figure 5: Small Cell Adjacent to Residential Properties

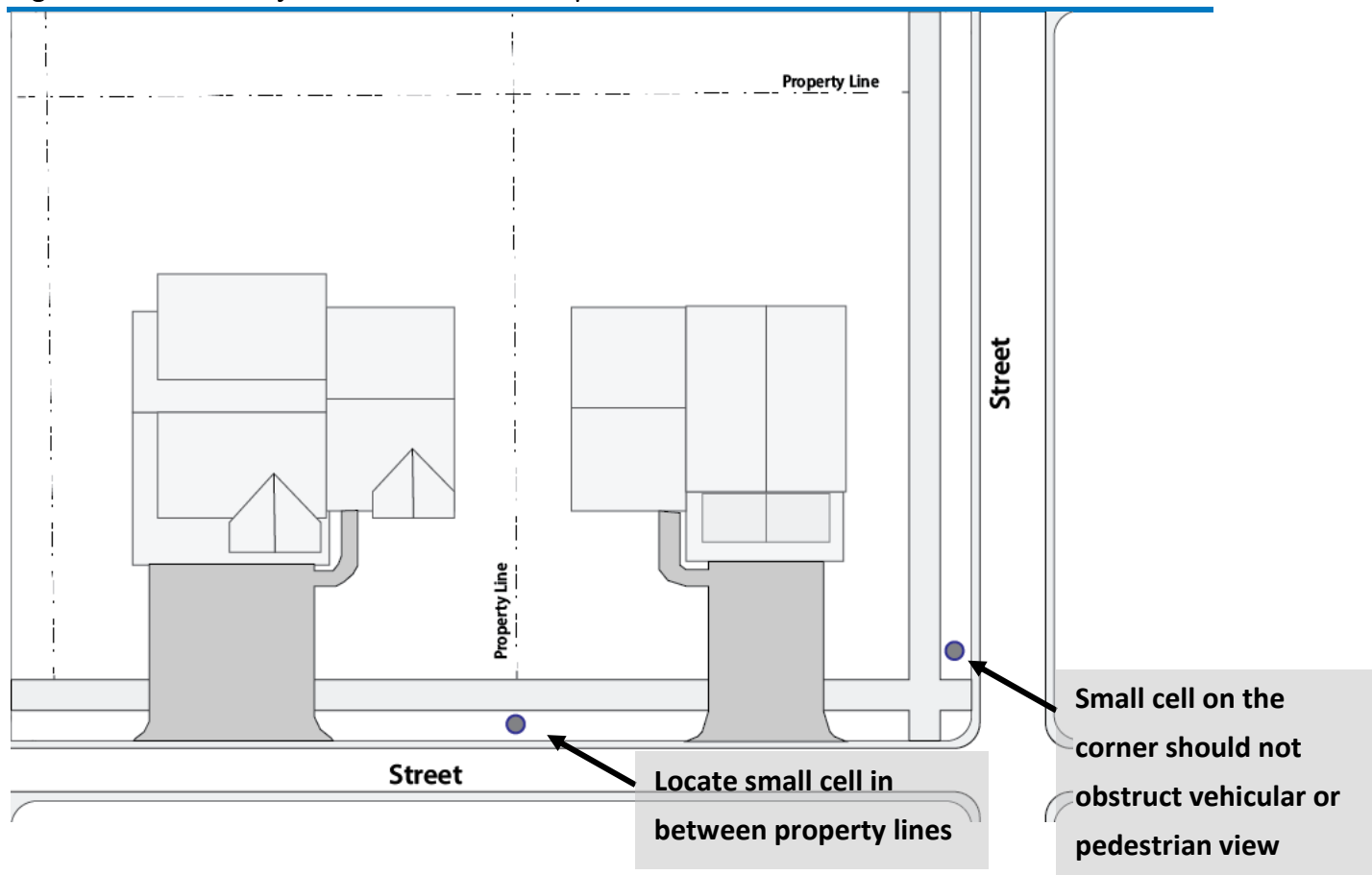

### Accessory Equipment

If pole-mounted locations are not available, ground-mounted antenna equipment shall use camouflage design techniques, including the use of materials, colors, screening, undergrounding, or other design options that will blend the new equipment into the surrounding setting. Accessory equipment shall be sited in a way that does not alter vehicular circulation or parking within the right-of-way or impede vehicular, bicycle, or pedestrian access or visibility along the right-of-way.

## DEFINITIONS

Definitions may also be referenced in Article 14 of the Lakewood Zoning Ordinance.

**Accessory Equipment:** Any small cell antennas and other wireless communication equipment serving or being used in conjunction with a small cell facility, including, but not limited to, nodes, antenna, cantenna, fiber optic cable, coaxial cable, wires, radios, conduit, pole, utility or transmission equipment, power supplies, generators, batteries, shroud, or other accessory components deemed by the wireless provider to be necessary to operate the wireless site.

**Antenna -** communications equipment that transmits or receives electromagnetic radio frequency signals used to provide wireless service.

**Applicant -** Any person that submits an application to the city to site, install, construct, collocate, modify, an/or operate a wireless communications facility.

**Camouflage Design Techniques -** The use of materials, colors, screening, undergrounding, or other design options that will blend the new equipment and existing pole into the surrounding setting.

**Cantenna –** that part of a small cell facility typically located at the top of small cell poles, that covers, shrouds, or otherwise camouflages that part of the facility used for the purpose of housing the antenna(s), antenna mount(s), cable connections, radio equipment and other hardware.

**Dual-Use Pole –** A pole that supports both street lighting and a small cell facility.

**FCC –** The Federal Communications Commission.

**Freestanding Small Cell Pole -** Any small cell facility that does not support electrical distribution, street lighting or other municipal purpose and is a height that is permitted in the Lakewood Municipal Code and/or in any license or permit agreement between the applicant and the city.

**Owner -** A person with a legal or equitable interest in ownership of real or personal property.

**Public rights-of-way or ROW -** Public roads, access ways, sidewalks, or similar facilities.

**Small Cell Facility –**each antenna is located inside an enclosure, real or imaginary, of no more than three (3) cubic feet and primary equipment enclosures are no larger than seventeen (17) cubic feet in volume. Associated equipment is not included in the calculation of the primary enclosure: electric meter, concealment, telecommunication demarcation box, back-up power

systems, grounding equipment, any permitted ground-based equipment, power transfer switch and cut-off switch.