

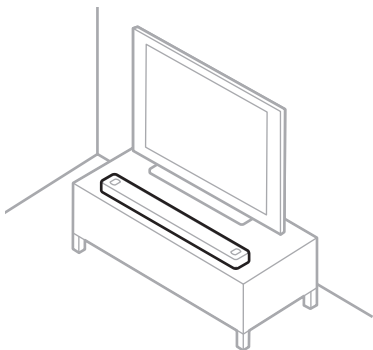

SMART SOUNDBAR 900

START HERE →

①



Place your soundbar

Keep at least 1 - 3 ft (0.3 - 0.9 m) away from other wireless equipment.

②

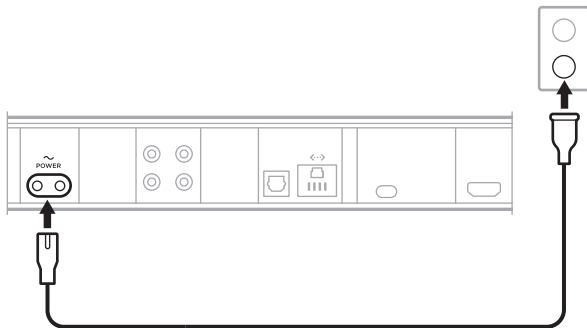

Connect to power

Your soundbar powers on, and the light bar glows solid amber.

3



4

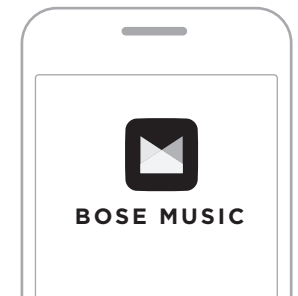

Download the Bose Music app to set up your soundbar



On your phone, use the camera to scan the QR code or go to app.Bose.com/SB900

Follow the app instructions to complete setup

You can also use the app to:

- Add music services.
- Customize the sound experience.
- Add a voice assistant.
- Get new features.

NOTE: For more information, refer to the owner's guide at worldwide.Bose.com/Support/SB900

①

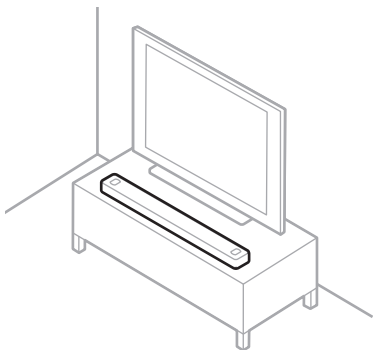

Placer din soundbar

Hold produktet mindst 0,3-0,9 meter væk fra andet trådløst udstyr.

②

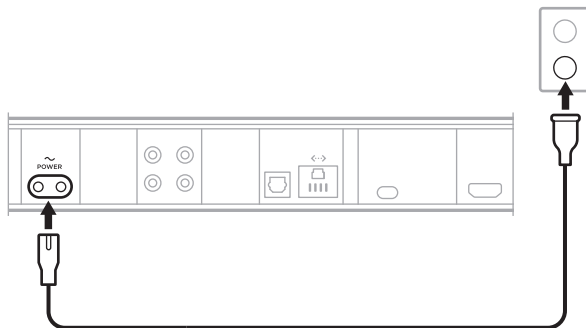

Slut til lysnettet

Din soundbar tændes, og lyslinjen lyser gult konstant.

3



4

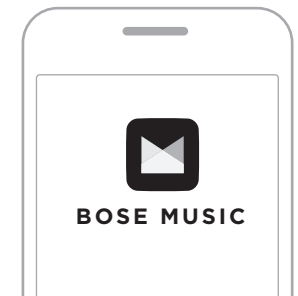

Download Bose Music-appen for at konfigurere din soundbar



På din telefon skal du bruge kameraet til at scanne QR-koden eller gå til app.Bose.com/SB900

Følg app-instruktionerne for at færdiggøre opsætningen

Du kan også bruge appen til at:

- Tilføje musiktjenester.
- Tilpasse lydoplevelsen.
- Tilføje en stemmeassistent.
- Få nye funktioner.

BEMÆRK: Du kan finde flere oplysninger i brugervejledningen på worldwide.Bose.com/Support/SB900

①

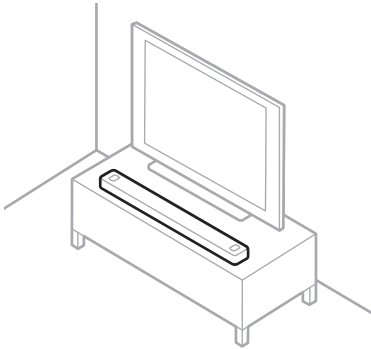

Aufstellen der Soundbar

Halten Sie mindestens 0,3 bis 0,9 m Abstand von anderen Drahtlosgeräten.

②

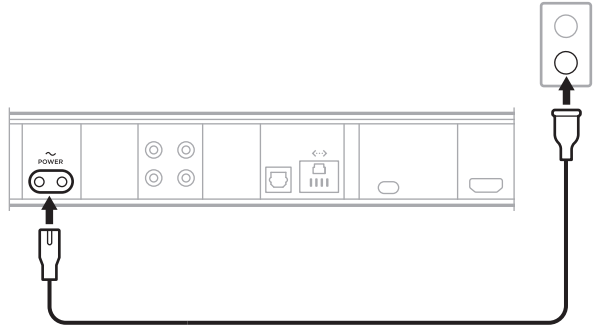

Anschluss an den Strom

Die Soundbar schaltet sich ein und die Lichtleiste leuchtet gelb.

3



4

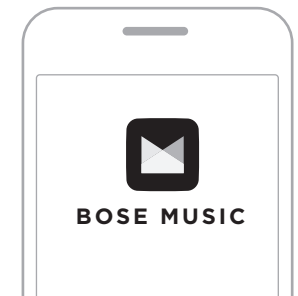

Laden Sie die Bose Music App herunter, um Ihre Soundbar einzurichten



Verwenden Sie die Kamera an Ihrem Telefon, um den QR-Code einzuscannen, oder gehen Sie zu app.Bose.com/SB900

Befolgen Sie die Anweisungen in der App, um die Einrichtung abzuschließen.

Sie können die App auch verwenden, um:
Musikdienste hinzuzufügen.
Das Klangerlebnis anzupassen.
Einen Sprachassistenten hinzuzufügen.
Neue Funktionen zu erhalten.

HINWEIS: Weitere Informationen finden Sie in der Bedienungsanleitung unter worldwide.Bose.com/Support/SB900

①

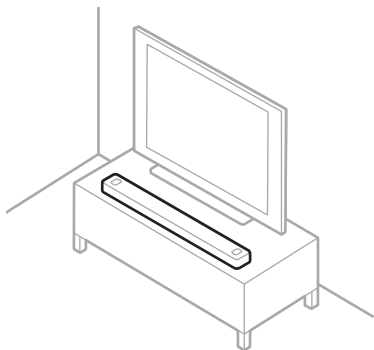

②

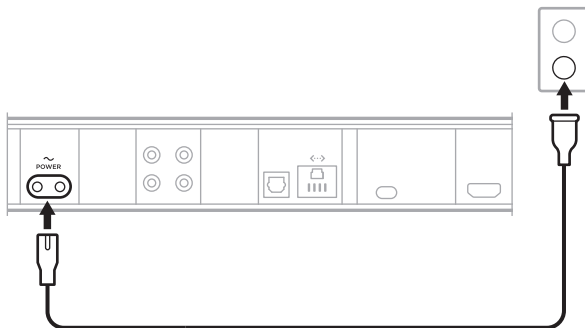

Plaats de soundbar

Plaats op een afstand van ten minste 30-90 cm van andere draadloze apparatuur.

Sluit aan op het lichtnet

De soundbar wordt ingeschakeld en de lichtbalk brandt continu oranje.

3



4

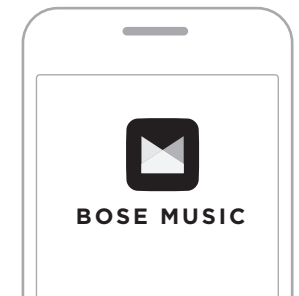

Download de Bose Music-app om de soundbar te configureren



Scan de QR-code met de camera op uw telefoon of ga naar app.Bose.com/SB900

Volg de instructies van de app om de configuratie te voltooien

U kunt de app ook gebruiken om:

- Muziekdiensten toe te voegen.
- De geluidsbeleving aan te passen.
- Een spraakassistent toe te voegen.
- Nieuwe functies te downloaden.

OPMERKING: Raadpleeg voor meer informatie de online gebruikershandleiding op worldwide.Bose.com/Support/SB900

①

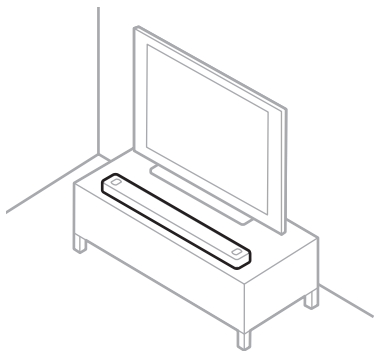

Colocar la barra de sonido

Mantener al menos a una distancia de 0,3 a 0,9 m de otros equipos inalámbricos.

②

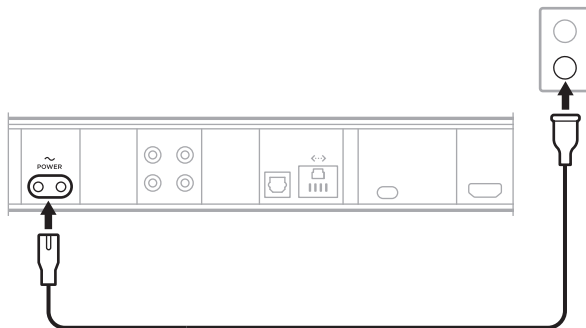

Conectar a la corriente

La barra de sonido se enciende y la barra de luces se ilumina de color ámbar.

3



4

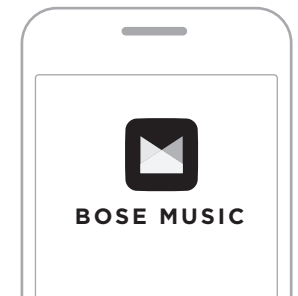

Descargar la aplicación Bose Music para configurar la barra de sonido



En el teléfono, use la cámara para escanear el código QR o vaya a app.Bose.com/SB900

Seguir las instrucciones de la aplicación para completar la configuración

También puede usar la aplicación para:

- Agregar servicios de música.
- Personalizar la experiencia de sonido.
- Agregar un asistente de voz.
- Acceder a nuevas funciones.

NOTA: Para obtener más información, consulte la guía del usuario en worldwide.Bose.com/Support/SB900

①

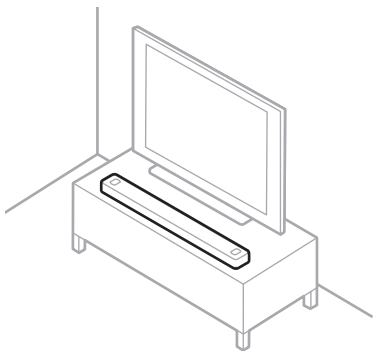

Aseta soundbar paikalleen

Pidä vähintään 0,3–0,9 metrin etäisyys muihin langattomiin laitteisiin.

②

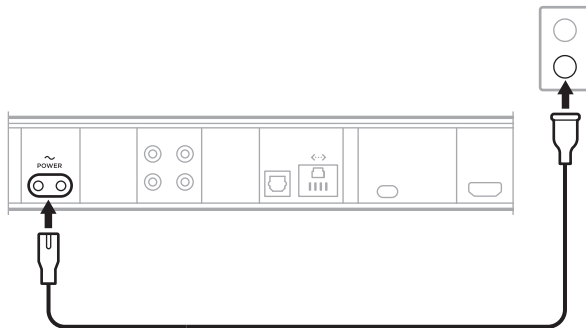

Liitä sähköpistorasiaan

Soundbar käynnistyy, ja valopalkki syttyy oranssina.

3



4

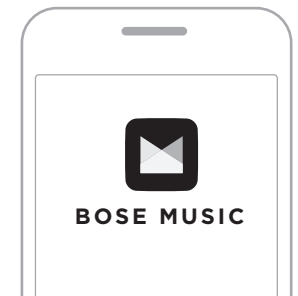

Lataa Bose Music -sovellus soundbarin määrittämistä varten



Skannaa QR-koodi puhelimella tai mene osoitteeseen app.Bose.com/SB900.

Tee määrytykset loppuun noudattamalla sovelluksen ohjeita

Sovelluksella voit myös lisätä musiikkipalveluita mukauttaa kuuntelukokemusta lisätä ääniavustajan saada uusia ominaisuuksia.

HUOMAUTUS: Lisätietoja on käyttöohjeessa osoitteessa worldwide.Bose.com/Support/SB900.

①

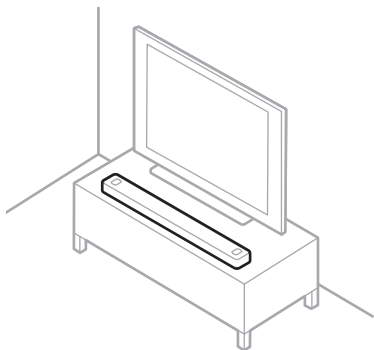

②

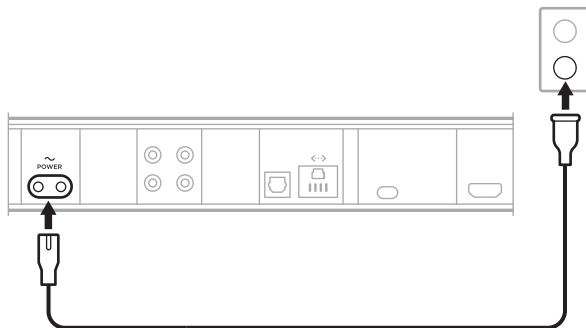

Positionnez la barre de son

Éloignez la barre de son de 0,3 à 0,9 m de tout autre appareil sans fil.

Raccordez la barre de son à la prise secteur

Votre barre de son se met en marche et la barre lumineuse s'allume en orange.

③



④

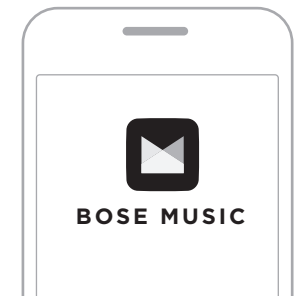

Téléchargez l'application Bose Music pour configurer votre barre de son



Utilisez l'appareil photo de votre téléphone pour numériser le code QR ou accédez à app.Bose.com/SB900

Suivez les instructions de l'application pour terminer la configuration

Vous pouvez également utiliser l'application pour :

- ajouter des services musicaux ;
- personnaliser l'expérience d'écoute ;
- ajouter un assistant vocal ;
- obtenir de nouvelles fonctionnalités.

REMARQUE : pour plus d'informations, consultez la notice d'utilisation sur le site worldwide.Bose.com/Support/SB900

①

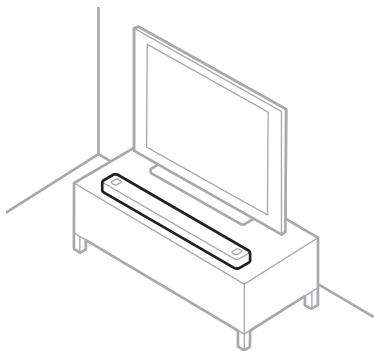

②

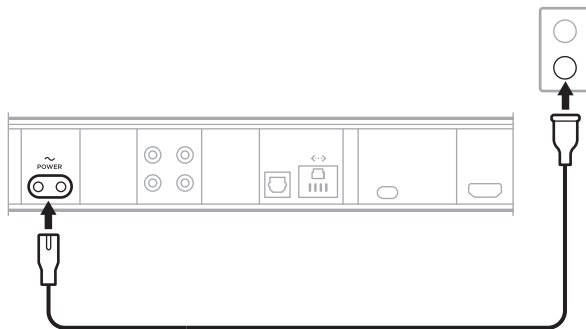

Posizionare la soundbar

Posizionare l'unità a una distanza minima di 30-90 cm da altre apparecchiature wireless.

Collegare all'alimentazione

La soundbar si accende e la barra luminosa emette una luce arancione fissa.

3



4

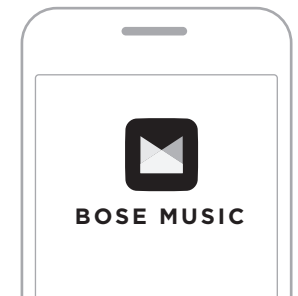

Scaricare l'app Bose Music per configurare la soundbar



Sul telefono, utilizzare la fotocamera per scansionare il codice QR oppure visitare app.Bose.com/SB900

Seguire le istruzioni dell'app per portare a termine la configurazione

È possibile usare l'app anche per:

- Aggiungere servizi musicali.
- Personalizzare l'esperienza d'ascolto.
- Aggiungere un assistente vocale.
- Scaricare nuove funzioni.

NOTA: Per ulteriori informazioni, consultare il manuale di istruzioni alla pagina web worldwide.Bose.com/Support/SB900

①

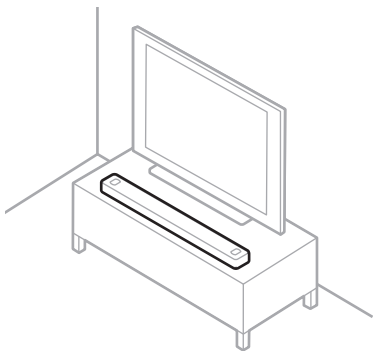

②

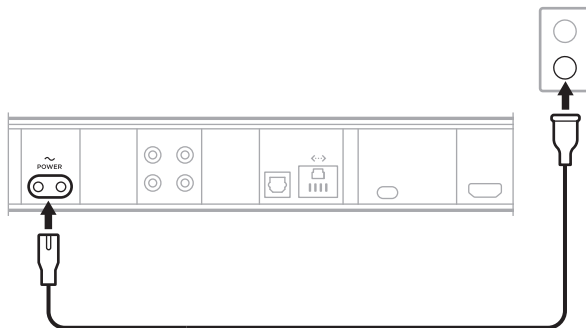

A hangsugárzó elhelyezése

Helyezze legalább 0,3–0,9 méterre a többi vezeték nélküli eszköztől.

Csatlakoztassa az áramforráshoz

A hangsugárzó bekapcsol, és a fénysáv folyamatos sárga fénnel világít.

3



4

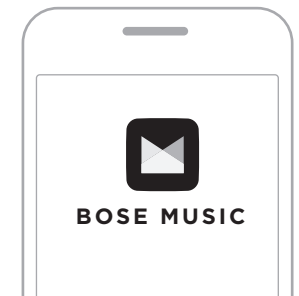

Töltse le a Bose Music alkalmazást a hangsugárzó beállításához



Telefonján a kamera segítségével olvassa be a QR-kódot, vagy keresse fel az app.Bose.com/SB900 címet.

Az alkalmazás utasításait követve végezze el a beállítást

Az alkalmazást használhatja a következőkhöz is:
Zeneszolgáltatások hozzáadása.
A hangélmény gomb testre szabása.
Hangsegéd hozzáadása.
Új funkciók beszerzése.

MEGJEGYZÉS: További információkat a kezelési útmutatóban olvashat a következő címen:
global.Bose.com/Support/SB900

①

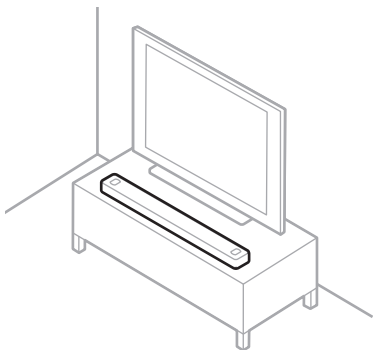

Plassere lydplanken

Plasser den minst 0,3-0,9 m borte fra annet trådløst utstyr.

②

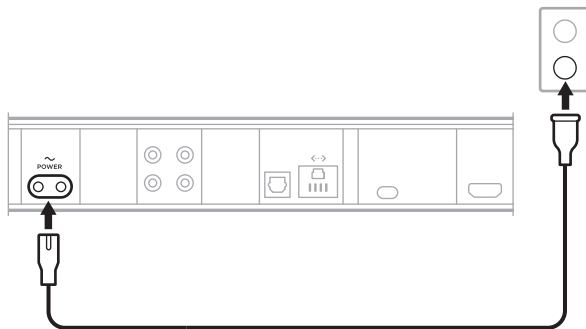

Koble til strøm

Lydplanken slås på, og lysfeltet lyser gult.

3



4

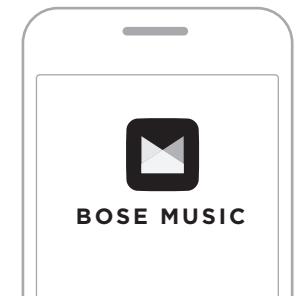

Last ned Bose Music-appen for å sette opp lydplanken



Bruk kameraet på telefonen til å skanne QR-koden, eller gå til app.Bose.com/SB900

Følg instruksjonene i appen for å fullføre oppsettet

Du kan også bruke-appen til å gjøre følgende:
legge til musikkjenester
tilpasse lydopplevelsen
legge til en taleassistent
få tilgang til nye funksjoner

MERKNAD: Hvis du vil ha mer informasjon, kan du se brukerveiledningen på worldwide.Bose.com/Support/SB900

①

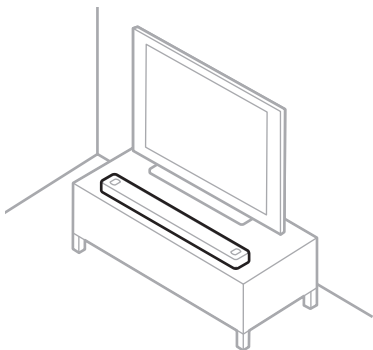

②

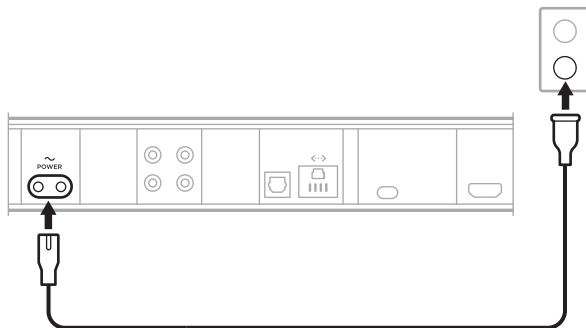

Umieść listwę dźwiękową w odpowiedniej lokalizacji.

Zachowaj odstęp co najmniej 0,3–0,9 m od innych urządzeń bezprzewodowych.

Podłącz zasilanie.

Zostanie włączone zasilanie listwy dźwiękowej i bursztynowy wskaźnik stanu.

3



Pobierz aplikację Bose Music, aby skonfigurować Listwę dźwiękową.



Zeskanuj kod QR za pomocą aparatu w telefonie lub przejdź pod adres app.Bose.com/SB900.

4

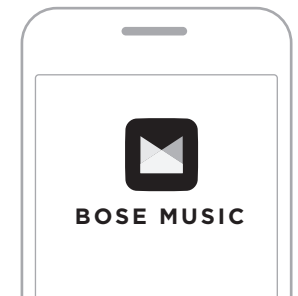

Aby dokończyć konfigurację, postępuj zgodnie z instrukcjami wyświetlanymi w aplikacji.

Możesz także użyć aplikacji do następujących celów:

- Dodawanie usług muzycznych
- Personalizowanie wrażeń dźwiękowych
- Dodawanie asystenta głosowego
- Dostęp do nowych funkcji

UWAGA: Aby uzyskać więcej informacji, zapoznaj się z podręcznikiem użytkownika na stronie worldwide.Bose.com/Support/SB900.

①

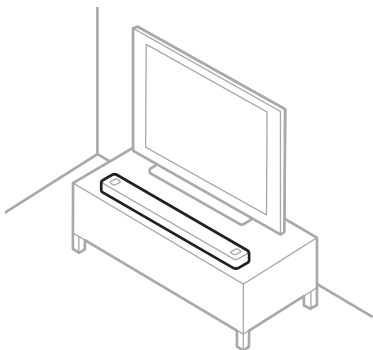

Posicione a barra de som

Mantenha uma distância de pelo menos 0,3 - 0,9 m de outros equipamentos sem fio.

②

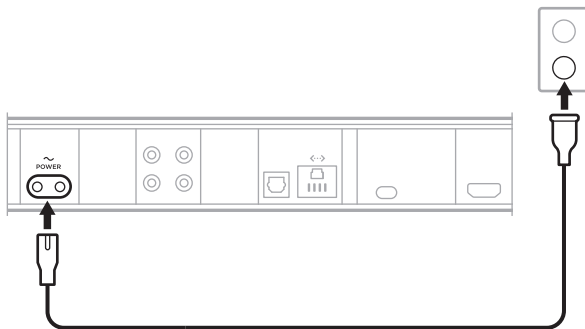

Conecte à energia

Sua barra de som será ligada, e a barra de luz se acenderá em âmbar sólido.

3



4

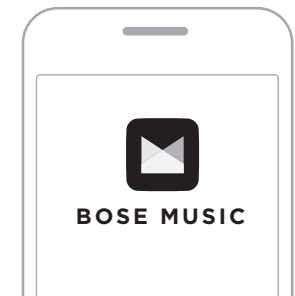

Baixe o aplicativo Bose Music para configurar sua barra de som



Em seu celular, use a câmera para ler o código QR ou acesse app.Bose.com/SB900

Siga as instruções do aplicativo para concluir a configuração

Você também pode usar o aplicativo para:

- Adicionar serviços de música.
- Personalizar a experiência de áudio.
- Adicionar um assistente de voz.
- Obter novos recursos.

OBSERVAÇÃO: Para obter mais informações, consulte o manual do proprietário em worldwide.Bose.com/Support/SB900

①

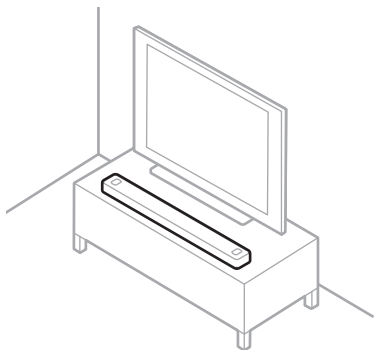

②

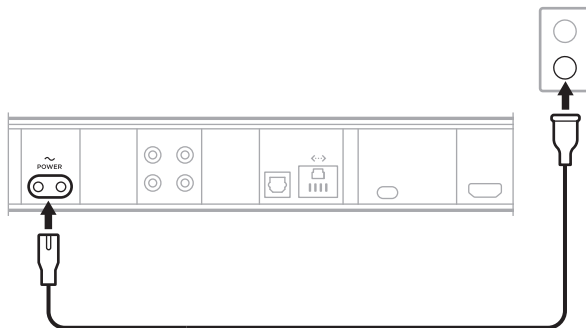

Soundbarhögtalarens placering

Se till att avståndet till annan trådlös utrustning är minst 0,3 – 0,9 m.

Anslut till en strömkälla

Soundbarhögtalaren startar och ljusrampen lyser med fast gult sken.

3



4

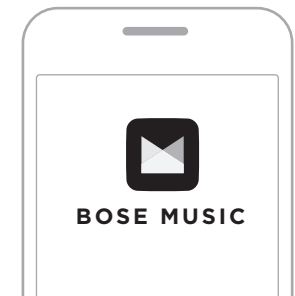

Ladda ner Bose Music-appen för att installera soundbarhögtalaren.



Använd din mobil för att skanna QR-koden eller besök app.Bose.com/SB900

Följ instruktionerna för appen för att slutföra installationen

Du kan även använda appen för att:
lägga till musiktjänster.
anpassa ljudet.
lägga till en röstassistent.
få nya funktioner.

OBS! Mer information finns i bruksanvisningen på worldwide.Bose.com/Support/SB900



worldwide.Bose.com/Support/SB900



868289-0010