

SmartROC D60

DTH surface drill rig for quarrying and mining

SmartROC D60 hole diameter: 110-178 mm (4.3-7")



Intelligent, tough and dependable

The SmartROC D60 down-the-hole rig from Epiroc is an intelligent drilling solution. The core of the machine is built on a trusted and well-proven platform.

The new efficient SmartROC D60 consistently delivers high-quality blast holes with accuracy and precision. It is loaded with smart features such as automated drilling and rod handling. The automation-ready platform also includes an Auto Feed Fold option. With a single action, the Auto Feed Fold enables the operator to fold the feed for tramming or position it for drilling. This also comes in handy when operating one or more drill rigs remotely with the BenchREMOTE option. The extra long feed with 8 meter pipes makes it possible to drill 16 m production holes with just one rod-adding. All these features and flexibility are packed in a rig which is economical to run due to the intelligent control of the compressor and engine rpm.

The SmartROC D60 also uses 300 liters less hydraulic oil than previous versions and features fewer hoses and pumps. This helps to further reduce costs and makes servicing easier, whilst increasing sustainability and reducing the environmental impact of the rig. The SmartROC D60 is controlled via an advanced rig control system displayed on a touch screen inside the comfortable, air-conditioned FOPS and ROPS-certified cabin. It presents everything from drilling parameters to real-time Measure While Drilling data (MWD). A SmartROC rig from Epiroc can significantly raise quality across the whole operation.





⊕ Main benefits

Intelligent, automated and future-proof as a result of Epiroc's unique Smart technology

Improved fuel consumption due to the automatic control of compressor-load and engine rpm

Efficient, productive and consistent thanks to automated drilling and rod handling

An intelligent rig which you can count on to deliver.

The SmartROC D60 is built to face the toughest of conditions. It's loaded with intelligent features that will improve your operations, increase safety and boost productivity. This rig is constantly evolving since its introduction in order to ensure that your investment delivers increased production and profitability shift-after-shift.



+ Increase drilling time with the extra long feed

The SmartROC D60 is available with an optional extra long feed (XLF). It carries 8 meter rods with a diameter of 89, 102, 114, 127 or 140 mm. The feed can also be easily adapted to take 6 meter rods if required. The XLF option means that the rig spends less time threading and unthreading rods. In addition, the drill string is extracted more rapidly. All this adds up to more holes drilled per shift which increases both production and profitability. In order to enhance stability, Rigs built with this option are also fitted with tracks placed further apart (wide kit).



+ Self-diagnostic capabilities

The SmartROC D60 is well-proven, tough and dependable. However, should a situation arise, the rig features an ingenious self-diagnostic system to help track down problems quickly and effectively to keep downtime to a minimum. SmartROC rigs are also designed to make life easier. The electrical system features a reduced number of cables for example – this reduces problems and makes troubleshooting much quicker.



+ Operate multiple rigs remotely

With the BenchREMOTE option, one person can safely control up to three rigs simultaneously from up to 100 meters away which dramatically increases operator productivity and takes safety to a whole new level. In combination with the Hole Navigation System (HNS), the BenchREMOTE removes the need for operators and surveyors to work in hazardous areas. The Auto Feed Fold option means the rig puts the feed in tramming position automatically – a great help when running rigs remotely.



A comprehensive service offering

Even the best equipment needs to be serviced regularly to make sure it sustains peak performance. An Epiroc service solution offers peace of mind, maximizing availability and performance throughout the lifetime of your equipment. We focus on safety, productivity and reliability.

By combining genuine parts and an Epiroc service from our certified technicians, we safeguard your productivity – wherever you are.

Main components

- Crawler type two speed undercarriage with track oscillation system
- CAT C15 turbo-charged diesel engines with Tier 3 or Tier 4 Final/Stage V technology
- Atlas Copco screw-type high-pressure compressors
- ROPS and FOPS-approved operator cabin with rubber vibration dampers
- Aluminum profile feed beam
- Single-section boom system
- Toe hole drilling capability on standard feed version
- Carousel type tube handling system
- Break-out table with pressure regulating kit
- Hydraulic operated rotary head
- Electric pump for filling hydraulic oil

Hole range & length (recommended)

		Metric	US
SmartROC D60	Hammer - COP 44 Gold, COP 54 Gold, COP 64 Gold	110-178 mm	4.33 - 7'
Max hole length with hydraulic rod handling system and 5 m (16.4') rods (Standard Feed - SF)			
SmartROC D60	Ø 89, 102, 114 mm (3.5", 4", 4.5") drill rods	45 m	148'
SmartROC D60	Ø 127, 140 mm (5", 5.5") drill rods	25 m	82'
Max hole length with hydraulic rod handling system, 6 m (20') rods and a 7.5 m (24.6') starter rod (Long Feed - LF)			
SmartROC D60	Ø 89, 102, 114 mm (3.5", 4", 4.5") drill rods	55.5 m	182'
SmartROC D60	Ø 127, 140 mm (5", 5.5") drill rods	31.5 m	103'
Max hole length with hydraulic rod handling system, 8 m (26.2') rods (Extra Long Feed - XLF)			
SmartROC D60	Ø 89, 102, 114 mm (3.5", 4", 4.5") drill rods	56 m	183.7'
SmartROC D60	Ø 127, 140 mm (5", 5.5") drill rods	40 m	181'
Single pass drilling, max hole depth			
SmartROC D60 standard feed	Ø 89, 102, 114 mm (3.5", 4", 4.5") drill rods	5.4 m	18'
SmartROC D60 long feed	Ø 127, 140 mm (5", 5.5") drill rods	7.5 m	24.6'
SmartROC D60 XL feed	Ø 127, 140 mm (5", 5.5") drill rods	8 m	26.3'

Rotary head

	Connection thread	Max rpm	Max torque, drilling		Suitable for DTH-hammer
			Metric	US	
DHR6 H 45	API 2 3/8" REG, box	137	1 839 Nm	1356 lbf	COP 44 Gold (COP 54 Gold)
DHR6 H 56	API 3 1/2" REG, box	107	2 353 Nm	1735 lbf	COP 54 Gold, COP 64 Gold, COP M6
DHR6 H 68	API 3 1/2" REG, box	68	5 800 Nm	2712 lbf	COP 64 Gold, COP M6
DHR6 H 78	API 3 1/2" REG, box	54	6 600 Nm	3417 lbf	COP 64 Gold, COP M6, COP M7

Electrical system

Voltage	24 V
Batteries	2 x 12 V, 235 Ah
Alternator	28 V, 95 Ah
Work lights, LED type, front	4 x 4 200 Lumen
Work lights, LED type, rear	2 x 4 200 Lumen
Work lights, LED type, feed	2 x 4 200 Lumen
Warning lamp and reverse alarm	

Aluminum feed

	Aluminum profile feed with hose guide and double drill tube support with break-out table and movable lower guide/dust hood	
	Metric	US
Feed rate, max	0.9 m/s	177 ft/min
Feed force, max	40 kN	8 992 lbf
Tractive pull, max	50 kN	11 240 lbf
Feed motor size	2099 cc	0.6 US gal
Chain size	45 mm	1.8"
Standard Feed		
Feed extension	1 150 mm	45.3'
Travel length	5 400 mm	212.6'
Total length	11 600 mm	456.7'
Long Feed		
Feed extension	1 900 mm	74.8'
Travel length	7 540 mm	296.8'
Total length	9 400 mm	370'
XL Feed		
Feed extension	1 150 mm	45.3'
Travel length	8 500 mm	334.6'
Total length	12 400 mm	488'

Dust collector

DCT 320 including pre-separator	Metric		US	
Filter area	32 m ²		344 sq.ft	
Suction capacity at 500 mm wg	1 270 l/s		2 690 cfm	
Suction hose diameter	203 mm		8"	
Cleaning air pressure, max	8 bar		116 psi	
Cleaning air consumption	2-4 l/pulse		0.06-0.12 cfm/pulse	
Number of filter elements	32 pcs			

Hydraulic system

Hydraulic oil cooler		
Max ambient temperature	55°C	131°F
Pumps		
Axial piston pump (1)	225 l/min	59.4 gal/min
Axial piston pump (2)	160 l/min	42.3 gal/min
Axial piston pump (3)	63 l/min	16.6 gal/min
Gear pump (4)	41 l/min	10.8 gal/min
Gear pump (5)	41 l/min	10.8 gal/min
Return and drainage filters (2 x 3 filters)		
Filtration rate	10 µm absolute	

Engine

CAT C15, turbo-charged, diesel engine, Tier 4 Final /EU Stage 5 (multi-certified for US and EU markets) or Tier 3/stage IIIA	Metric		US	
Power rating @ 1800 rpm	354 kW		475 hp	

Compressor

Atlas Copco XRX 10, two stage screw type compressor	Metric		US	
Working pressure, max	25 bar		363 psi	
FAD at 25 bar	405 l/s		858 cfm	

Carrier

	Metric	US
Tramming speed, max	3.2 km/h	2.0 mph
Traction force, max	138 kN	31 020 lbf
Ground clearance	405 mm	16"
Track oscillation	±10°	

Volumes

	Metric	US
Hydraulic oil tank	120 l	31.7 gal
Hydraulic system, total	270 l	71.3 gal
Compressor oil	63 l	12 gal
Diesel engine oil	44 l	11.6 gal
Diesel engine, coolant, Tier 3	65 l	17 gal
Diesel engine, coolant, Tier 4	110 l	29 gal
Diesel engine, fuel tank	975 l	258 gal
Traction gear	3 l	0.8 gal
Lubrication tank (HECL)	20 l	5.3 gal
DEF fluid tank (Tier 4 final only)	34 l	9 gal

Weight

Standard unit excluding all options and drill rods (OM)	Metric		US	
SmartROC D60 long feed	Tier 3 = 25 550 kg	Tier 4 = 25 800 kg	Tier 3 = 56 328 lb	Tier 4 = 56 879 lb
SmartROC D60 standard feed	Tier 3 = 24 900 kg	Tier 4 = 25 150 kg	Tier 3 = 54 895 lb	Tier 4 = 55 446 lb
SmartROC D60 XL feed	Tier 3 = 26 450 kg	Tier 4 = 26 700 kg	Tier 3 = 58 312 lb	Tier 4 = 58 863 lb

Technical specifications

A robust feed with inbuilt sensors means fewer breakdowns and more reliable rod handling.

Semi automatic feed alignment system ensures that the hole angle is exactly as desired.



Discover more about the SmartROC D60.

The fully-automated drill cycle allows you to reach desired hole depth while drill tubes are added and extracted automatically.

Smart options such as the Hole Navigation System (HNS) reduces your non-drilling time and improves precision.



Cabin

- ROPS and FOPS approved with rubber vibration dampers
- 2 x wipers with washer
- Clear laminated glass (front and roof windows)
- Clear toughened glass (side and rear windows)
- Fully adjustable, electrically heated operator seat
- Foot rest
- Cabin light
- Air conditioning/heating
- Rig inclination indicator
- Rear view mirror
- 24 V outlet socket
- Prepared for CD radio
- Electric combined engine/inclination hole depth instrument

Optional equipment

Carrier

- Wide body kit
- Hydraulic support leg
- Protection hand rails on top of canopy
- Extra LED worklight package
- Heavy duty air intake filters for engine and compressor
- Combined warning sound and beacon
- Manual or automatic Ansul Checkfire 210 fire extinguisher system
- Electric fuel filling pump
- Fast fuel-filling system
- Diesel-driven engine pre-heater
- Insulated and heated compressor regulation system
- Arctic Fox -40°C cold start
- Battery sliding tray

Water mist system

- Water mist system, pump, one or two 400 l water tanks
- Arctic-ready water mist system, pump, one or two 400 l water tanks

Cabin

- 6 kg dry chemical fire extinguisher, type ABE class III
- Clear laminated glass (front and roof windows)
- Tinted toughened glass (side and rear windows)
- Sunshade kit
- Radio/CD
- Reverse camera with display integrated into main display

Feed

- Service winch with jib boom mounted on the feed
- Wide feed foot
- Protective guard, according to EN16228
- 35" pre-splitting boom system
- Reverse Circulation (RC)
- Screw sampler device
- Pre-split suction hood
- Auto Feed Fold

Lubrication

- Central lubrication system, type Lincoln
- Thread lubrication, spray system
- Artic hydraulic oil, VG 32
- Tropical hydraulic oil, VG 68
- Biological hydraulic oil, VG 46

Hole and inclination systems

- Hole Navigation System
- GPS compass aiming unit
- Laser receiver

Automation and software

- BenchREMOTE remote operator station
- Rig Remote Access
- Surface Manager Reporting
- Rig Access control
- Configurable safety software

Parts and services products

- ROC Care

Optional accessories

- Tool kit for rotary head with fixed spindle sub
- Tool kit for rotary head with floating spindle sub
- Lubrication kit
- RCS tool box

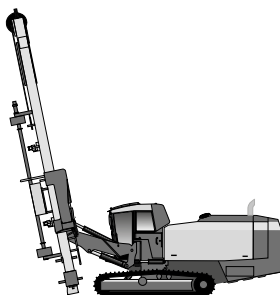

Horizontal body	
D60 XLF	-15.5°
D60 XLF with auto feed fold	-8.5°

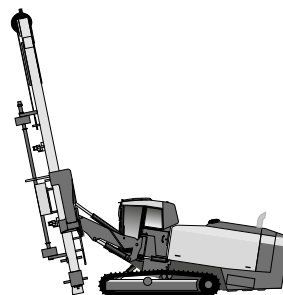

Backwards tilt body: 10°	
D60 XLF	-20.5°
D60 XLF with auto feed fold	-11.5°

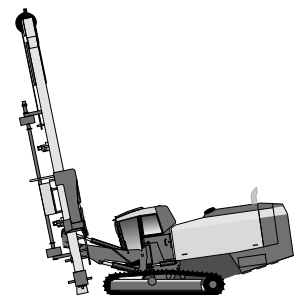

Front tilt body: 10°	
D60 XLF	-11°
D60 XLF with auto feed fold	-4°

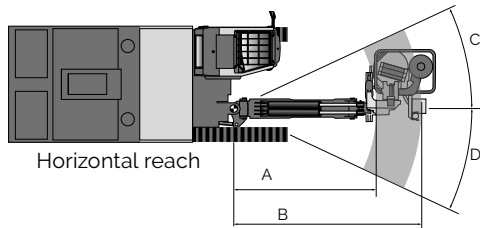

Horizontal reach (mm)	A	B	C	D
Standard feed (with or without Auto Feed Fold)	2 700	3 190	25'	25'
Long feed/XLF	2 577	3 075	17'	13'
Long feed/XLF Auto Feed Fold	2 660	2 890	17'	13'

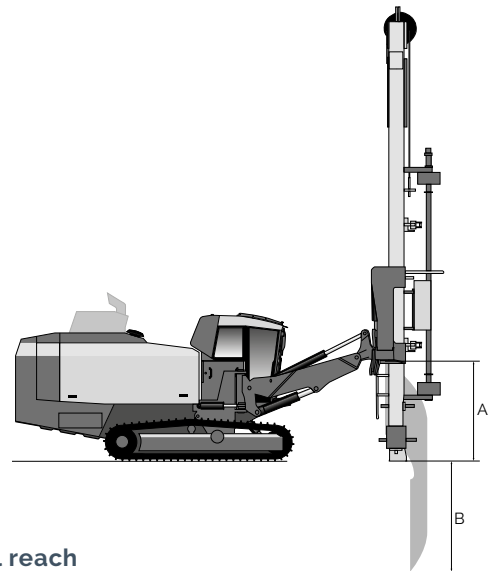

Vertical reach

	A (Metric)	B (Metric)	A (US)	B (US)
Long feed	582 mm	2 277 mm	23'	90'
Standard feed	1 040 mm	2 659 mm	41'	105'
XL feed	672 mm	2 195 mm	26.4'	86.4'

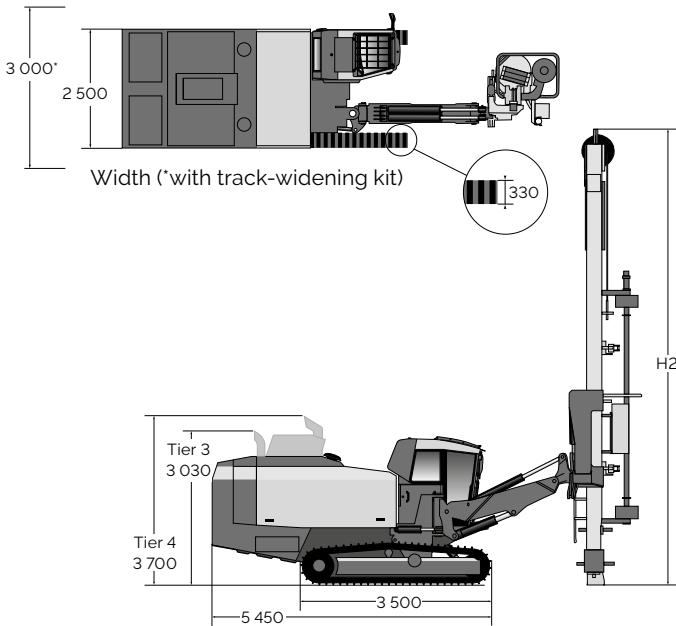

Height and length

Long feed (LF) dumped	Metric	US
Height (H1)	3 500 mm	138'
Length (L1)	11 600 mm	457'
XL feed dumped		
Height (H1)	3 500 mm	138'
Length (L1)	12 400 mm	488'
Standard feed (SF) dumped		
Height (H1)	3 500 mm	138'
Length (L1)	9 300 mm	366'
Feed height (H2)		
Long feed (LF)	11 600 mm	457'
Standard feed (SF)	9 400 mm	370'
XL feed	12 400 mm	488'

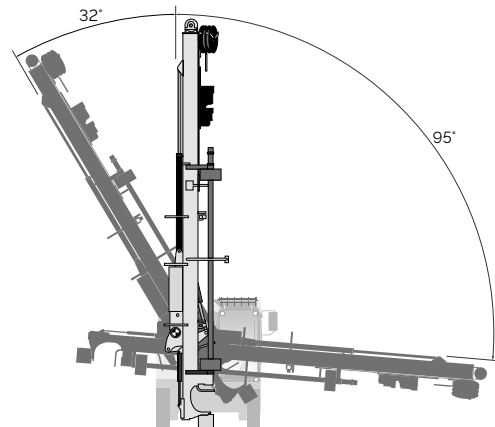
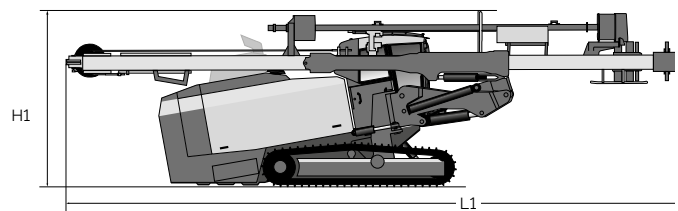

Feed swing angles - standard feed

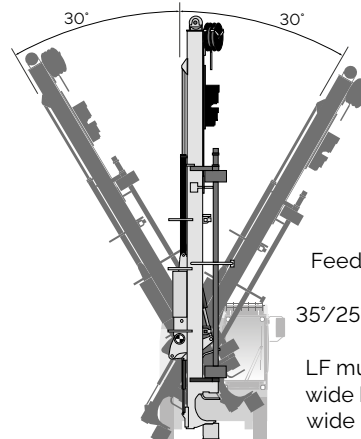

Feed swing angles - long feed/XL feed 35°/25° with 35° pre-splitting boom system. LF must be equipped with wide body kit. XL feed has wide body kit as standard.

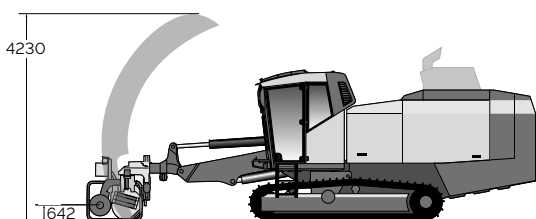

Toe-hole drilling (standard feed only)



9868 0154 01a 2020-01 Orebro, Sweden. Legal Notice © Copyright 2020 Epiroc Rock Drills AB, Orebro, Sweden. All product names in this publication are trademarks of Epiroc. Any unauthorized use or copying of the contents or any part thereof is prohibited. Illustrations and photos may show equipment with optional extras. No warranty is made regarding specifications or otherwise. Specifications and equipment are subject to change without notice. Consult your Epiroc Customer Center for specific information.

United in performance. Inspired by innovation.

Performance unites us, innovation inspires us, and commitment drives us to keep moving forward. Count on Epiroc to deliver the solutions you need to succeed today and the technology to lead tomorrow.
epiroc.com

