

INSTALLATION GUIDE

Installation Guide:

Oct. 2013

Rev. E

Big Ass Fan Company
2348 Innovation Drive
Lexington, KY 40511
1-877-BIG-FANS
www.bigassfans.com

May be covered by one or more of the following United States patents:

6,244,821; 6,589,016; 6,817,835; 6,939,108; 7,252,478; 7,284,960; D587,799; D607,988; 7,654,798; D635,237; 7,934,907; D641,075; D642,674; 8,075,273; D650,893; 8,079,823; 8,147,182; 8,147,204; 8,152,453; 8,162,613; and other patents pending.

SmartSense365™ is a trademark of Delta T Corporation. All other trademarks used herein are the properties of their respective owners.

Contents

Introduction	Thank You.....	1
	About Big Ass Fans.....	1
	About the SmartSense365™.....	1
Pre-Installation	What's in the Box.....	2
	Dimensions.....	3
Mounting the SmartSense365™	Overview.....	4
	SmartSense365 with Powerfoil®X2.0 and Powerfoil®X2.0 Plus Fans.....	5
	SmartSense365 with Powerfoil®8 and Powerfoil®8 Plus Fans.....	6
	Mounting the Remote Temperature Sensor.....	7
	Mounting the Wall Controller.....	8
Electrical Installation	Electrical Installation Safety.....	9
	Power Guidelines.....	9
	Single Fan Installation for PowerfoilX2.0 and PowerfoilX2.0 Plus Fans.....	10
	Multi-Fan Installation (Daisy Chaining) for PowerfoilX2.0 and PowerfoilX2.0 Plus Fans.....	11
	Single Fan Installation for Powerfoil8 and Powerfoil8 Plus Fans.....	12
	Multi-Fan Installation (Daisy Chaining) for Powerfoil8 and Powerfoil8 Plus Fans.....	13
	Alternative Wiring Methods.....	14
Operating the SmartSense365	Starting and Stopping the Fan.....	15
	Modes of Operation.....	16
Programming the SmartSense365	Selecting a Mode.....	17
	Programming Winter Mode Maximum Fan Speed.....	17
	Programming Summer Mode Minimum and Maximum Temperatures.....	17
	Adjusting Manual Mode Fan Speed.....	17
Troubleshooting	Wall Controller.....	18
	Remote Temperature Sensor.....	18



IMPORTANT SAFETY INSTRUCTIONS READ AND SAVE THESE INSTRUCTIONS

WARNING: This guide is intended to provide a basic overview for integrating a SmartSense365™ with a Big Ass Fan. Consult the Installation Guide included with the fan for additional installation and operation instructions.

WARNING: Disconnect fan and controller from power supply before installing the SmartSense365.

WARNING: To reduce the risk of electric shock, wiring should be performed by a qualified electrician! Incorrect assembly can cause electric shock or damage the motor and the controller! Hazard of electrical shock!

WARNING: Installation must be in accordance with the National Electrical Code, ANSI/NFPA 70-2011, and all local codes. The procedures and techniques outlined in this manual are merely a guide for proper installation. Code compliance is your responsibility! Failure to comply with these codes could result in personal injury or property damage.

WARNING: The fan controllers contain high voltage capacitors which take time to discharge after removal of mains supply. Before working on the fan controller, ensure isolation of mains supply from line inputs at the fan controller's disconnect (L1, L2/N, 3). Wait three minutes for capacitors to discharge to safe voltage levels. Failure to do so may result in personal injury or death. *Note: Darkened display LEDs are not an indication of safe voltage levels.*

WARNING: When service or replacement of a fan component requires the removal or disconnection of a safety device, the safety device is to be reinstalled or remounted as previously installed.

CAUTION: The Big Ass Fans product warranty will not cover equipment damage or failure that is caused by improper installation.

ATTENTION: If installing the fan in the United States, the fan must be installed per the following National Fire Protection Association (NFPA) guidelines:

- The fan must be centered approximately between four adjacent sprinklers.
- The vertical distance from the fan to the sprinkler deflector must be at least 3 ft (91.4 cm).
- The fan must be interlocked to shut down immediately upon receiving a waterflow signal from the alarm system.

Introduction

Thank you and congratulations on your purchase of a Big Ass Fan, an efficient and cost-effective way to stay cool in the summer and warm in the winter. The revolutionary design of our fans combines the best of both form and function to bring power performance and a sleek look to any setting. More importantly, you have purchased a product that is backed by extensive research, thorough testing, and quality manufacturing. We're ready to answer any questions or comments at 1-877-BIG-FANS or visit our Web site at www.bigassfans.com.

Who we are and what we do

Big Ass Fans has been the preeminent manufacturer of large-diameter, low-speed fans since 1999. With a worldwide presence and located in beautiful Lexington, KY, we research, design, and manufacture the most effective air movement solutions on the market. Our never-ending commitment to quality and innovation keeps us at the leading edge of a burgeoning industry. With an eye to helping customers satisfy their needs, and a strong sense of corporate responsibility to the community, Big Ass Fans has redefined the way business is done.

About the SmartSense365™

The SmartSense365™ is engineered to maximize both energy savings and comfort through year-round control of your Big Ass Fan.

Wall Controller

Supply voltage	+24VDC, 100mA
Power consumption	≤1W
Output	4–20mA DC current loop
Wiring	18–22 AWG
Operating temperature	32°–100°F (0°–38°C)
Humidity	95% Relative humidity. Board is conformal coated.
Storage temperature	14°–122°F (-10°–50°C)
ESD withstand voltage	+/- 4kV Air, +/- 4kV Contact

Remote Temperature Sensor

Supply voltage	+10VDC to +24VDC
Power consumption	≤1W
Output	4–20mA DC current loop
Accuracy/Non-linearity	+/-1°@ 77°F/ +/-0.5°F
Wiring	18–22 AWG
Operating temperature	32°–100°F (0°–38°C)
Humidity	95% Relative humidity. Board is conformal coated.
Storage temperature	14°–122°F (-10°–50°C)
ESD withstand voltage	+/- 4kV Air, +/- 4kV Contact

Wiring

Max wiring distance (ft)	$((V_{\text{supply}} - 10V) / 0.02A) / (\text{Wire Ohms per Foot} \times 2)$
--------------------------	--

Note: There is no concern regarding wiring distance regardless of wire gauge used. Using the formula above, the maximum wiring distance between devices would be 18,421 ft (3.5 mi) if 22 AWG stranded is used (0.019 ohms per ft).

2

Pre-Installation

What's in the box

⚠ CAUTION: The wall controller and remote temperature sensor contain sensitive electronic PCBs. Use extreme care when handling! ESD precautions recommended.

The SmartSense365™ is shipped in a single box and packaged in static shielding materials for ESD protection. Dashed lines indicate internal boxes. Review the information below to ensure you have received all necessary components for installation and operation.

Note: Drawings are not to scale.

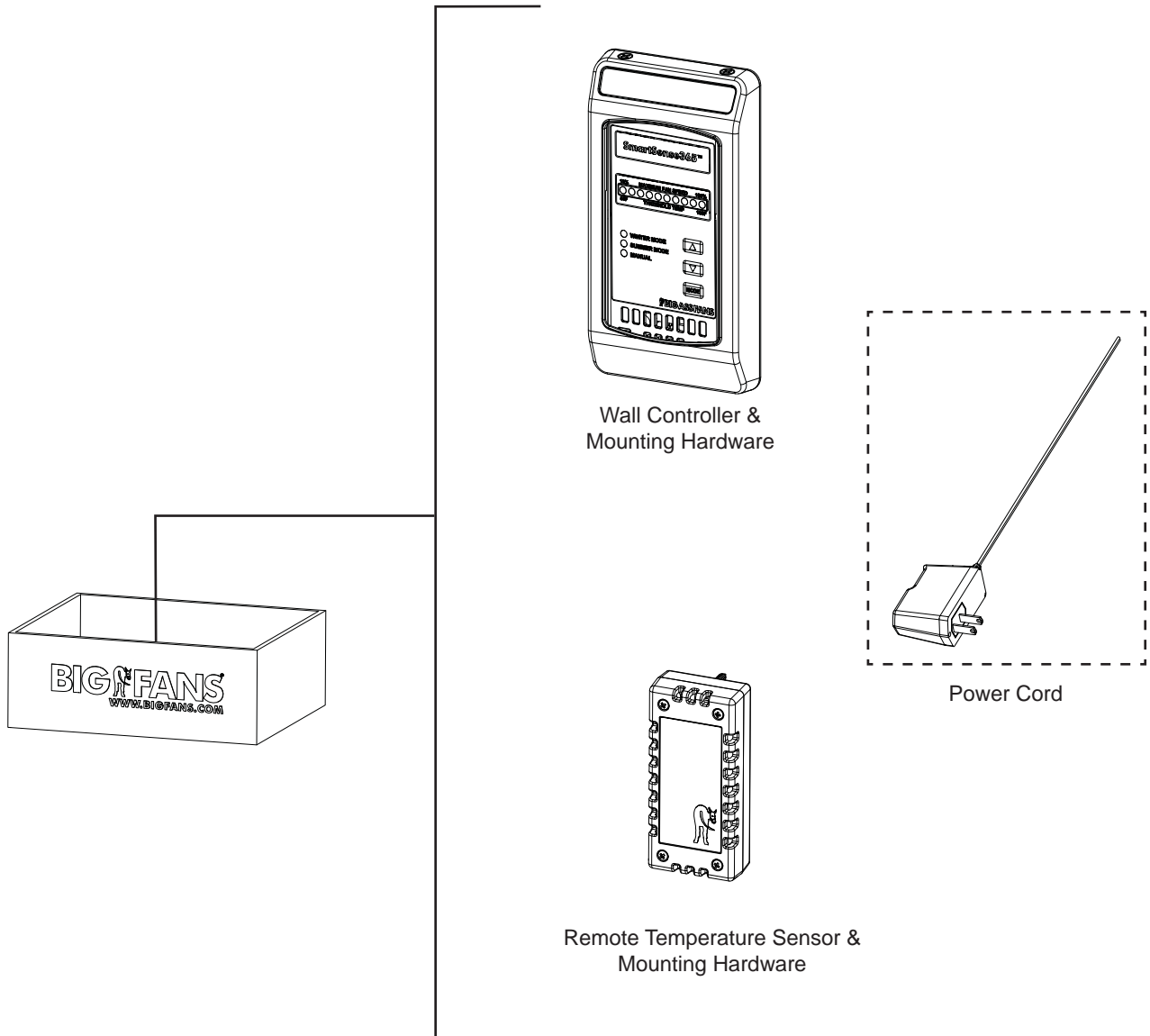

Dimensions

Remote Temperature Sensor

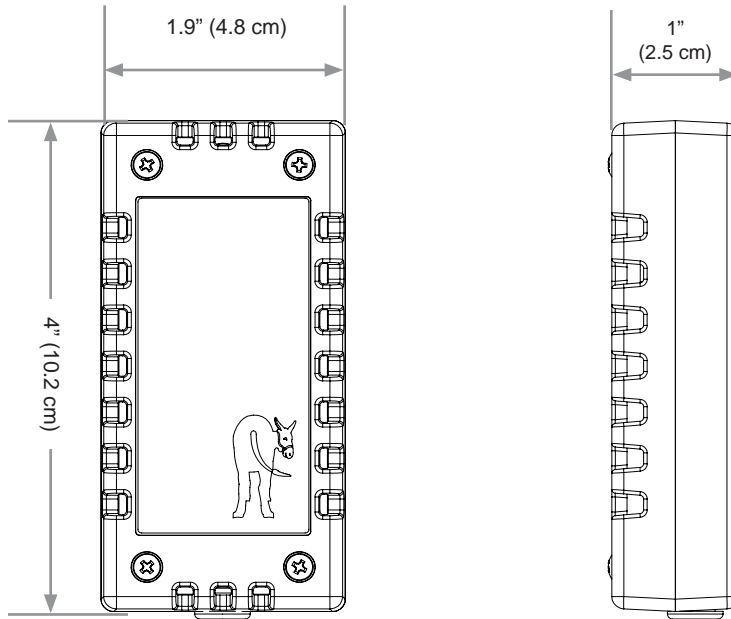

Mounting Plate

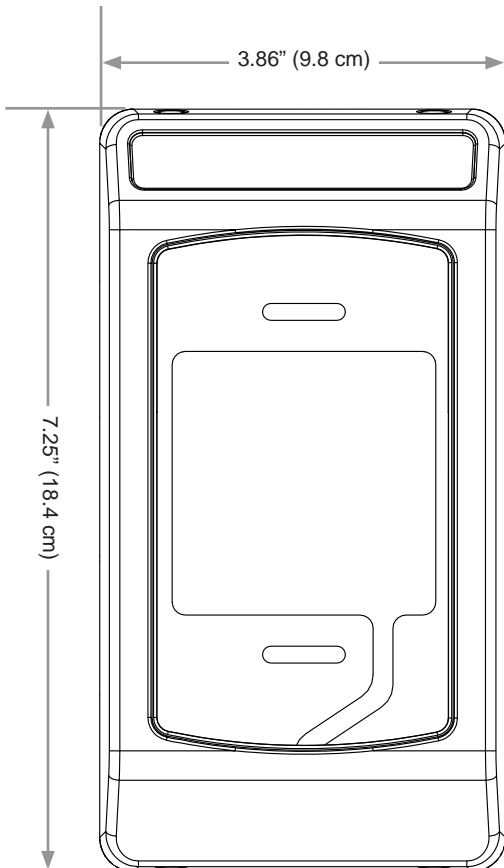

Depth: 1" (2.5 cm)

Wall Controller

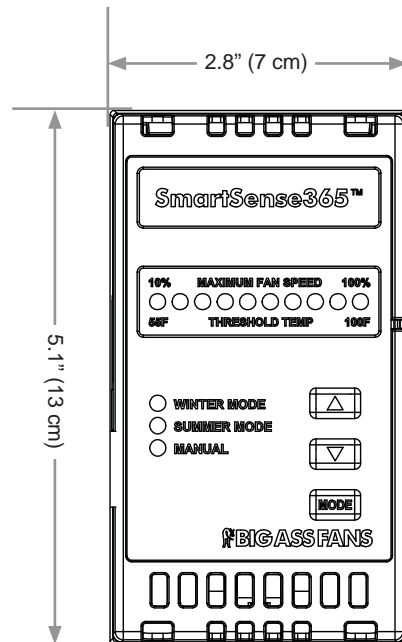

4 Mounting the SmartSense365™

⚠ WARNING—TO REDUCE THE RISK OF FIRE, ELECTRIC SHOCK, OR INJURY TO PERSONS, OBSERVE THE FOLLOWING:

- a. Installation work and electrical wiring must be done by qualified person(s) in accordance with all applicable codes and standards.
- b. When cutting or drilling into a wall or ceiling, do not damage electrical wiring or other hidden utilities.

Overview

The SmartSense365™ relies on air temperature readings obtained at the locations of the wall controller and remote temperature sensor. Proper mounting locations are essential to the successful adjustment of the room temperature. Refer to the diagram and guidelines below.

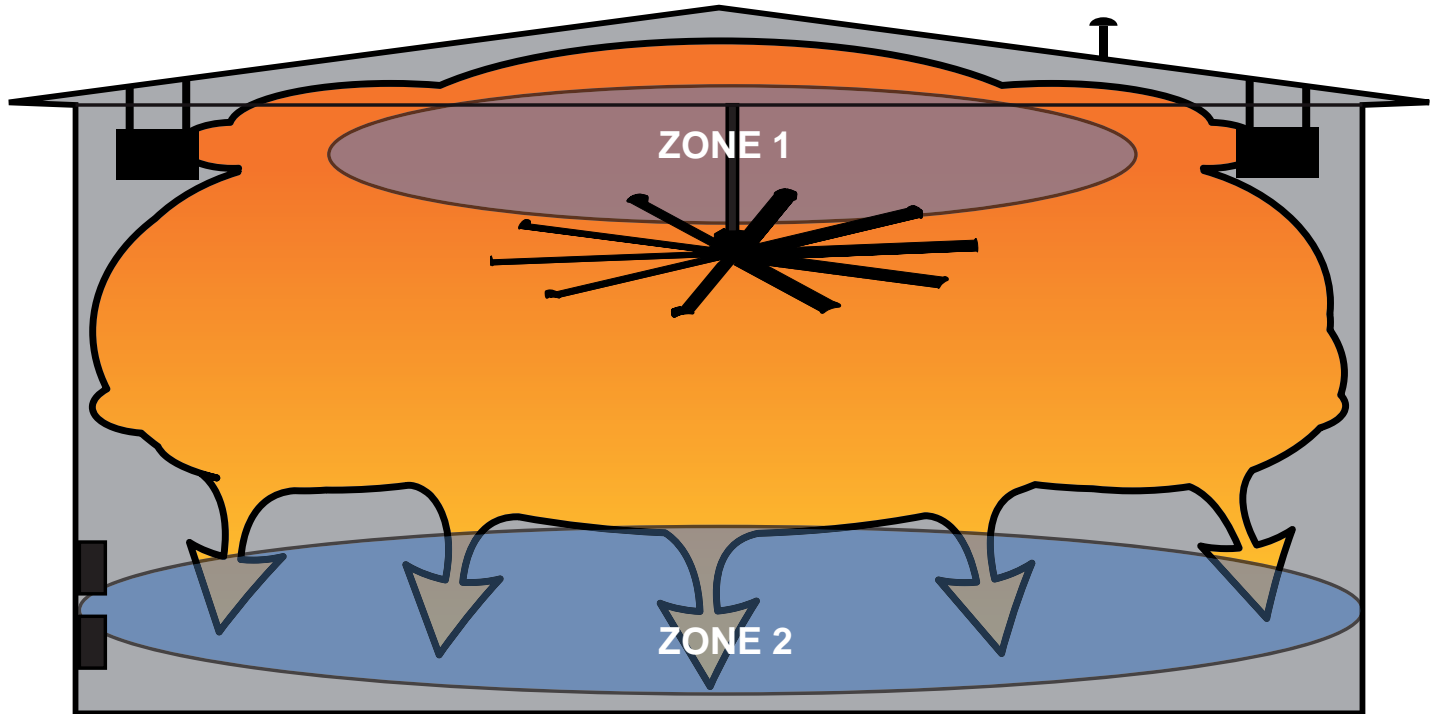

ZONE 1. The remote temperature sensor must be mounted in the upper portion of the room (Zone 1) in order to obtain an accurate temperature reading at the ceiling level.

ZONE 2. The wall controller must be mounted in the lower portion of the room (Zone 2) to obtain an accurate reading at the floor level.

Install the wall controller and remote sensor on flat surfaces that are free from vibration and where there is adequate distance from foreign objects or moving equipment. The wall controller should be readily accessible.

Do not mount the wall controller or remote sensor in the following locations:

- Adjacent to or above radiant heaters
- Near HVAC ventilation intakes or exhausts
- On poorly insulated exterior walls
- In roof decking
- Near radiant heat sources

Mounting the SmartSense365™ (cont.)

SmartSense365™ with Powerfoil®X2.0 and Powerfoil®X2.0Plus fans

Refer to the diagram below for the general installation of a SmartSense365™ with Powerfoil®X2.0 and Powerfoil®X2.0Plus fans.

Note: The PowerfoilX2.0/PowerfoilX2.0Plus fan wall controller and the SmartSense365 wall controller do not have to be mounted adjacent to one other; each device is wired independently. Wiring for both wall controllers can be routed in the same conduit.

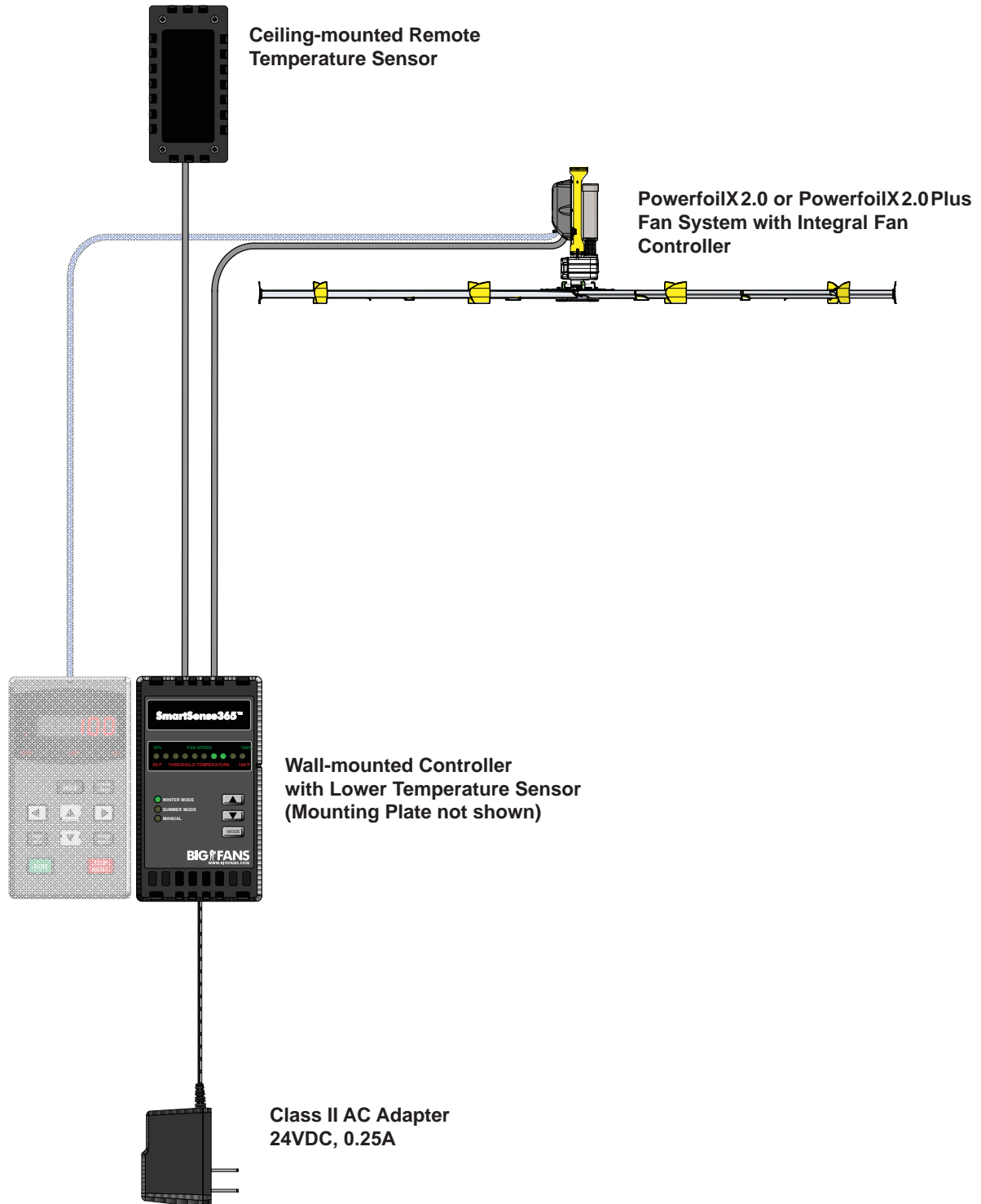

6

Mounting the SmartSense365™ (cont.)

SmartSense365™ with Powerfoil®8 and Powerfoil®8Plus fans

Refer to the diagram below for the general installation of a SmartSense365™ with Powerfoil®8 and Powerfoil®8Plus fans.

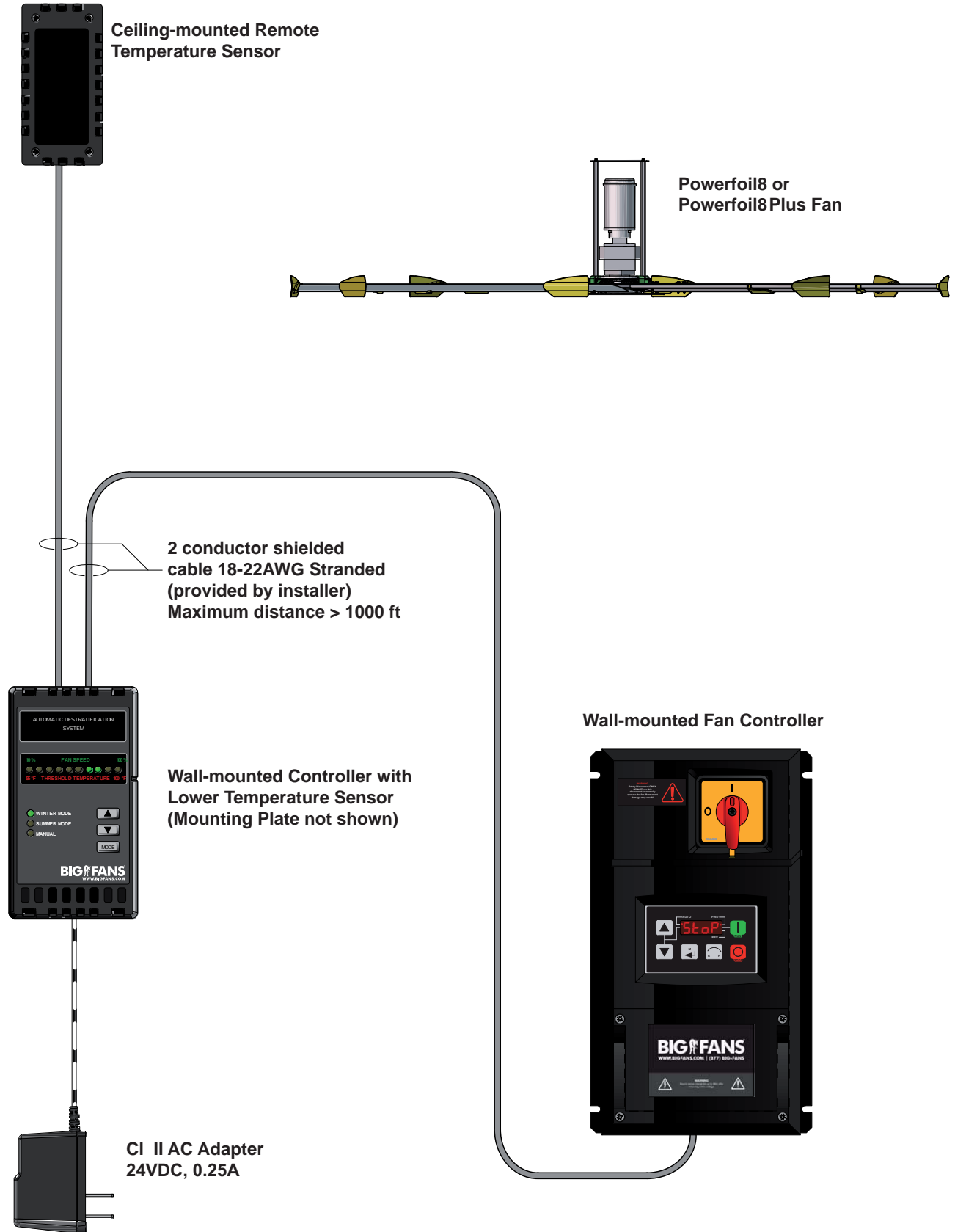

Mounting the remote temperature sensor

⚠ CAUTION: The wall controller and remote temperature sensor contain sensitive electronic PCBs. Use extreme care when handling! ESD precautions recommended.

Do not lose the rubber grommet during installation.

The remote temperature sensor is designed to be surface mounted in a location near the ceiling. *Note: Wiring for the remote sensor must be completed at the same time the sensor is mounted.*

To mount the remote temperature sensor, loosen the (4) screws and remove the cover from the remote sensor. Using the back of the sensor as a template, mark the (2) screw locations on the mounting surface. Loosely install the mounting screws on the mounting surface in the hole locations. Slide the remote over the screws, and then tighten the screws. Before reattaching the front cover, complete the wiring. See p. 9 for details and wiring diagrams. *Note: The remote temperature sensor can be mounted in any orientation.*

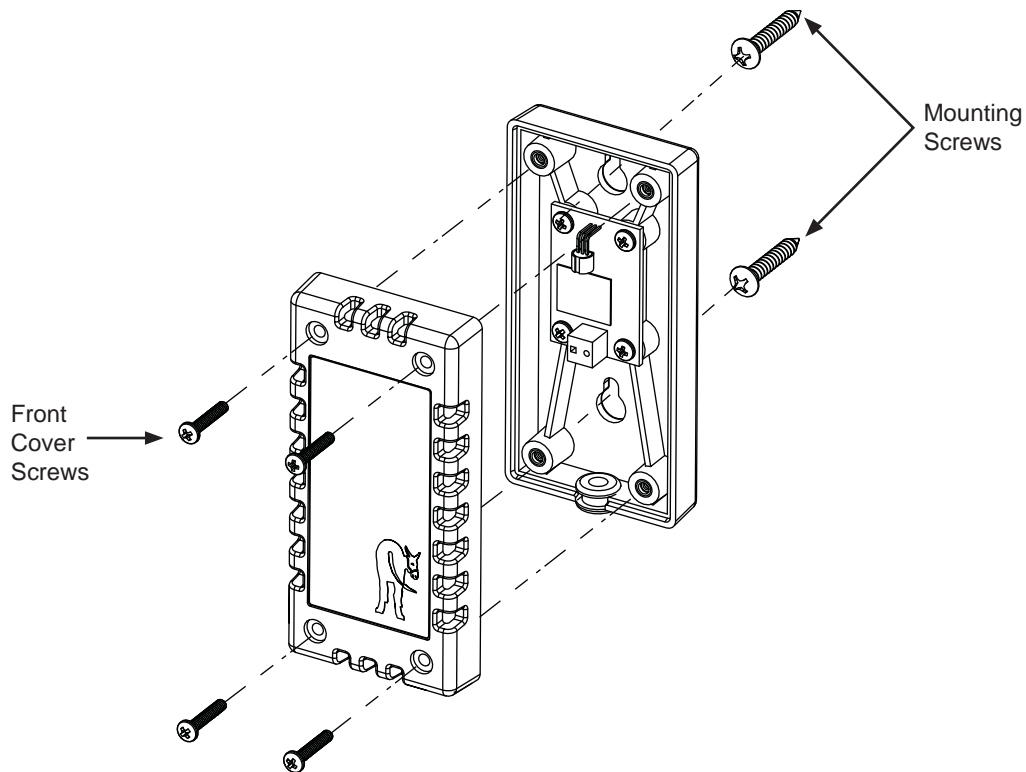

8 Mounting the SmartSense365™ (cont.)

Mounting the wall controller

⚠ CAUTION: The wall controller and remote temperature sensor contain sensitive electronic PCBs. Use extreme care when handling! ESD precautions recommended.

The SmartSense365™ wall controller can be mounted to a standard 2" x 4" electrical switch box or surface-mounted on a wall or column. It does not have to be located adjacent to the fan controller; each controller is independently wired to the fan. *Note: A junction box is not supplied with the wall controller.*

Before mounting the SmartSense365 wall controller, route the wiring to the predetermined location.

To install the wall controller:

1. Attach the mounting plate to the junction box in the wall with the two (2) provided 6-32 x 7/8" pan head screws. Route the SmartSense365 wall controller power cord through the opening in the center of the mounting plate. Guide the power cord down the bottom of the mounting plate in the slot provided.
2. Rest the wall controller in the wall controller cover, and then secure the controller cover to the mounting plate with the four (4) provided 6-32 countersink screws as shown below.

Mounting Hardware:

- a. (2) 6-32 x 7/8" Pan Head Screw
- b. (4) 6-32 Countersink Screw

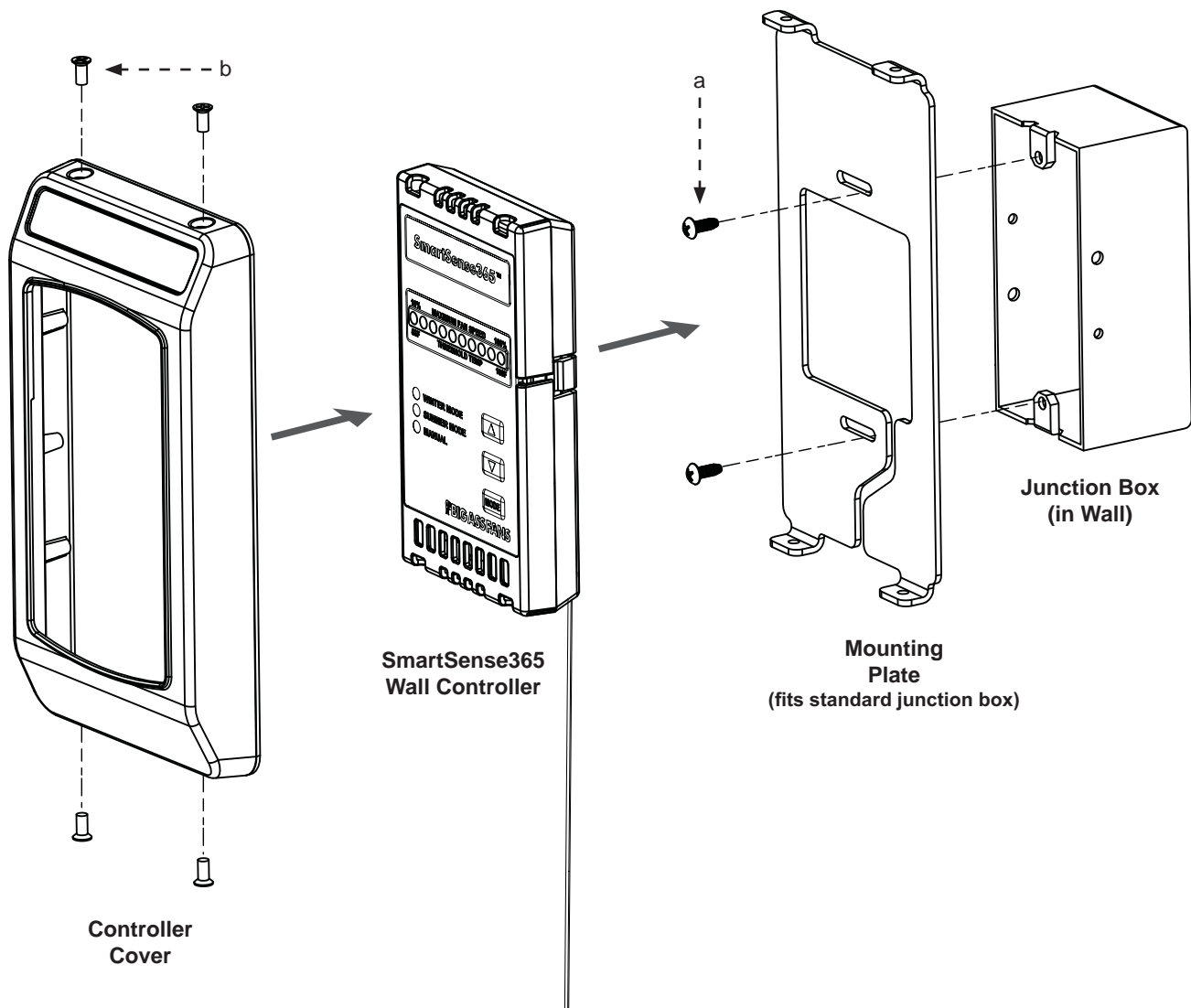

Electrical Installation



WARNING: Disconnect fan and controller from power supply before installing the SmartSense365™.

WARNING: To reduce the risk of electric shock, wiring should be performed by a qualified electrician! Incorrect assembly can cause electric shock or damage the motor and the controller! Hazard of electrical shock!

WARNING: Installation must be in accordance with the National Electrical Code, ANSI/NFPA 70-2011, and all local codes. The procedures and techniques outlined in this manual are merely a guide for proper installation. Code compliance is your responsibility! Failure to comply with these codes could result in personal injury or property damage.

WARNING: The fan controllers contain high voltage capacitors which take time to discharge after removal of mains supply. Before working on the fan controller, ensure isolation of mains supply from line inputs at the fan controller's disconnect (L1, L2/N, L3). Wait three minutes for capacitors to discharge to safe voltage levels. Failure to do so may result in personal injury or death. *Note: Darkened display LEDs are not an indication of safe voltage levels.*

Power guidelines

Wall Controller

Supply voltage	+24VDC, 100mA
Power consumption	≤1W
Output	4–20mA DC current loop
Wiring	18–22 AWG
ESD withstand voltage	+/- 4kV Air, +/- 4kV Contact

Remote Temperature Sensor

Supply voltage	+10VDC to +24VDC
Output	4–20mA DC current loop
Accuracy/Non-linearity	+/-1° @ 77°F / +/-0.5°F
Wiring	18–22 AWG
ESD withstand voltage	+/- 4kV Air, +/- 4kV Contact

10

Electrical Installation (cont.)

Single fan installation for Powerfoil®X2.0 and Powerfoil®X2.0Plus fans

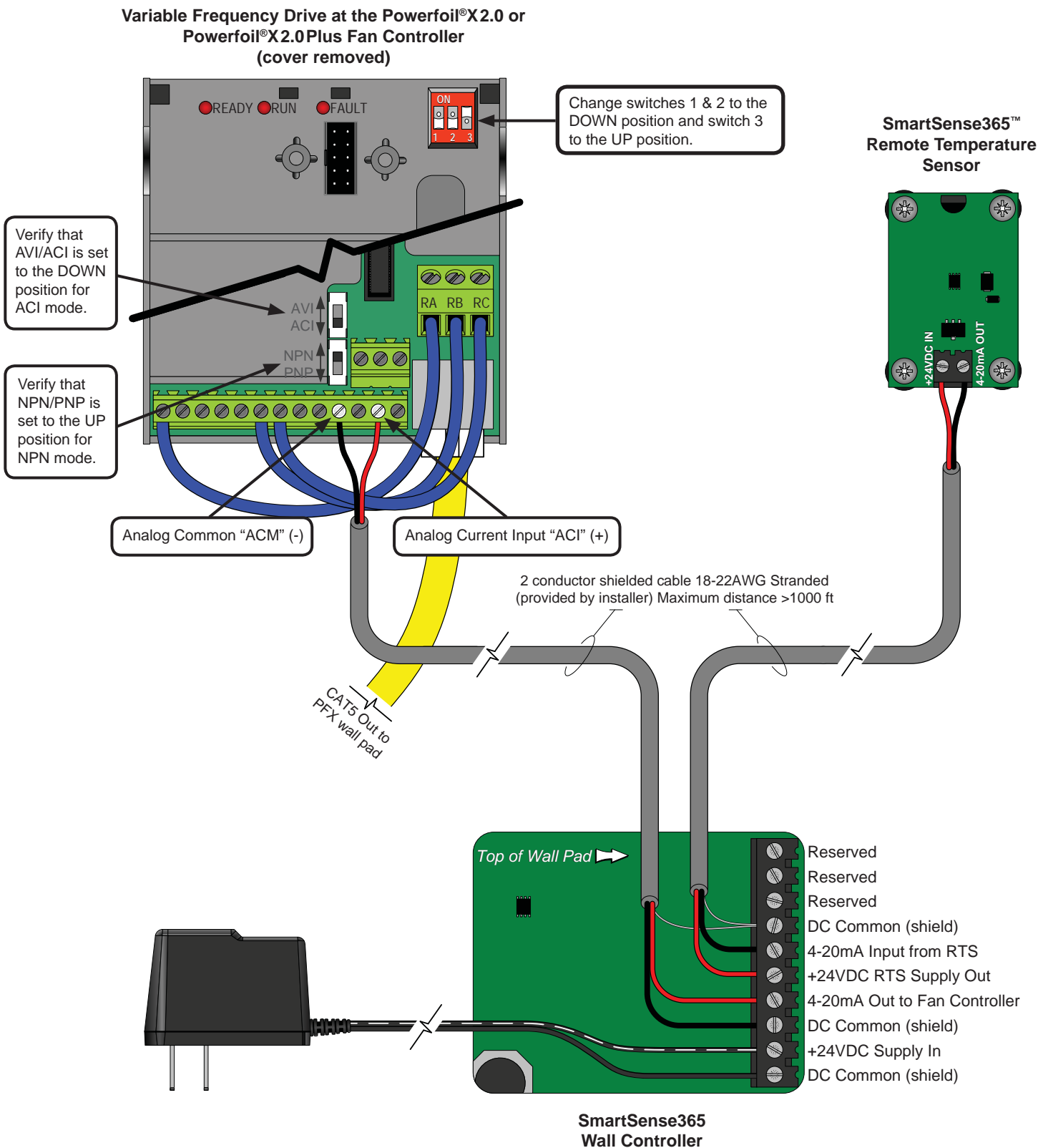

Electrical Installation (cont.)

Multi-fan installation (daisy chaining) for Powerfoil®X2.0 and Powerfoil®X2.0Plus fans

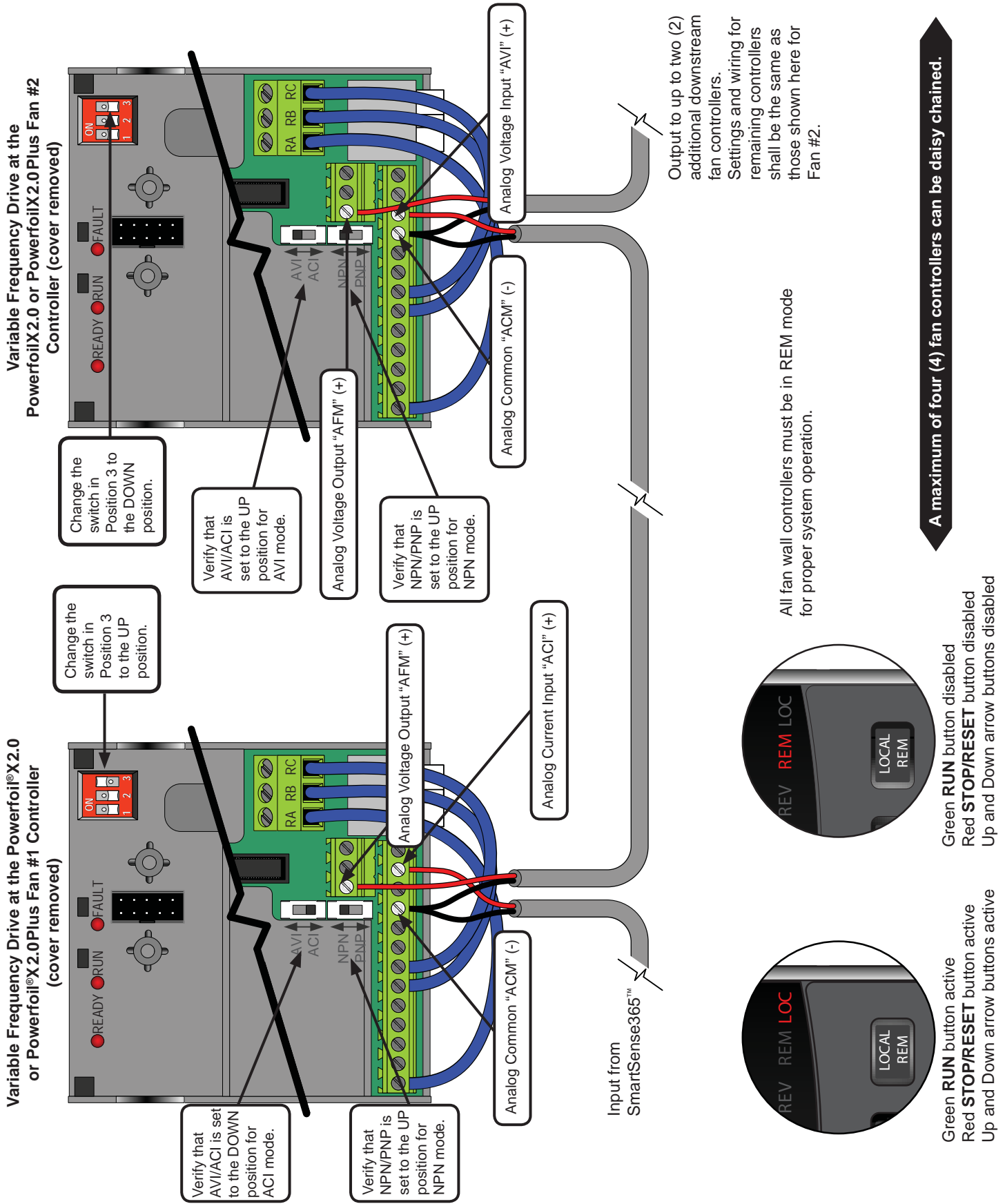

12

Electrical Installation (cont.)

Single fan installation for Powerfoil®8 and Powerfoil®8 Plus fans

Parameter Changes ARE required

P101 'Standard Reference Source' must be changed from "0" for keypad operation to "2" for 4-20mA analog input operation

Variable Frequency Drive at the Powerfoil®8 or Powerfoil®8 Plus Fan Controller (cover removed)

SmartSense365™ Remote Temperature Sensor

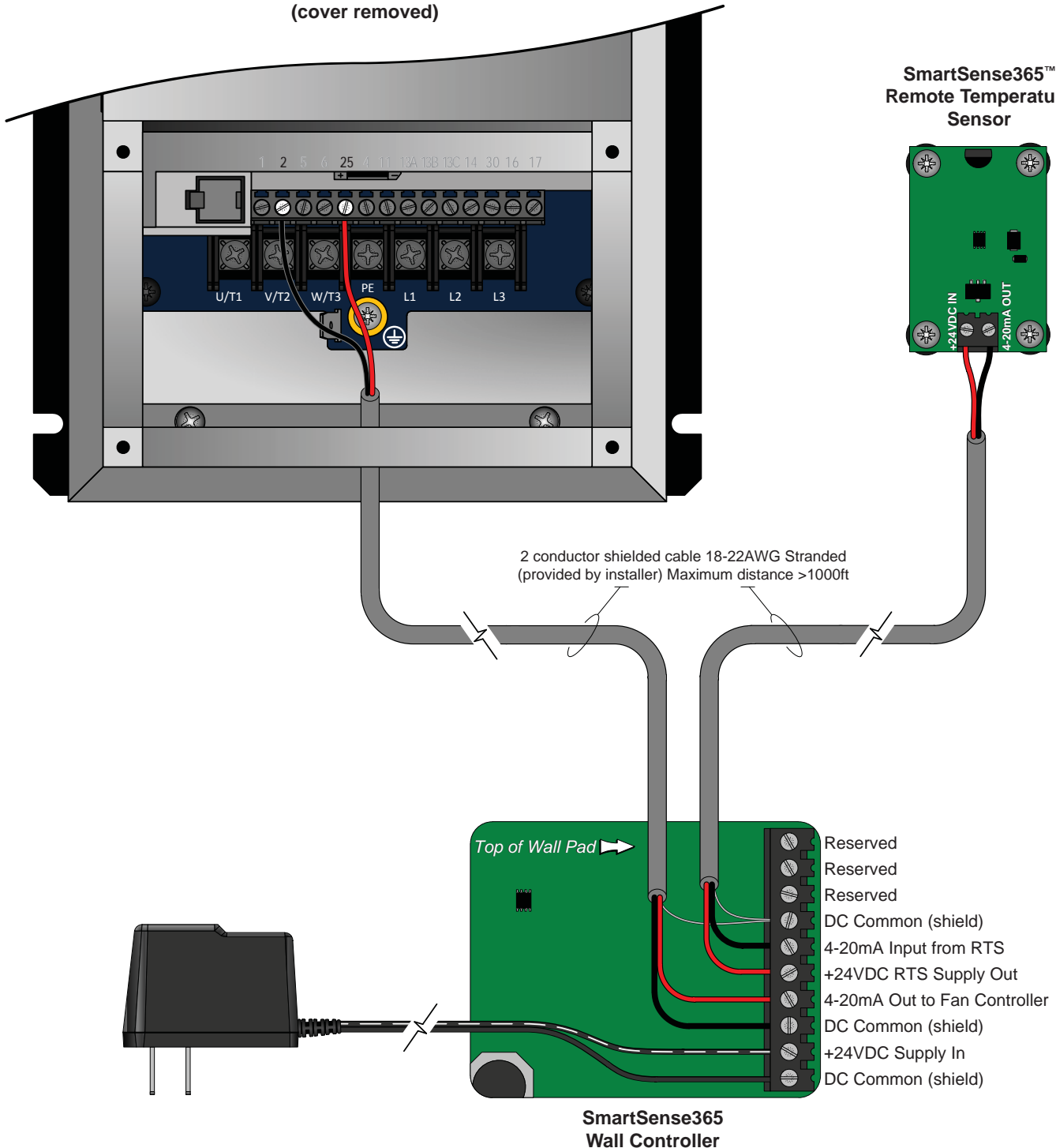

Multi-fan installation (daisy chaining) for Powerfoil®8 and Powerfoil®8Plus fans

The following parameter changes are required on all downstream fan controllers

- P101 'Standard Reference Source' must be changed from "0" for keypad operation to "1" for 0-10VDC analog input operation
- P102 'Minimum Frequency' must be changed from "10.0" to "0.0" for proper minimum speed reference scaling from preceding fan controller
- P150 'TB-30 Output' must be changed from "0" for None to "1" for 0-10VDC output (scaled to drive output frequency)
- P152 'TB-30 Scaling Frequency' must be changed to equal the frequency setting of P103 'Maximum Frequency'
- P160 'Speed at Minimum Signal' must be changed from "10.0" to "0.0" for proper minimum speed reference scaling from preceding fan controller.

The following parameter changes are required on the first fan controller

- P101 'Standard Reference Source' must be changed from "0" for keypad operation to "2" for 4-20mA analog input operation
- P150 'TB-30 Output' must be changed from "0" for None to "1" for 0-10VDC output (scaled to drive output frequency)
- P152 'TB-30 Scaling Frequency' must be changed to equal the frequency setting of P103 'Maximum Frequency'

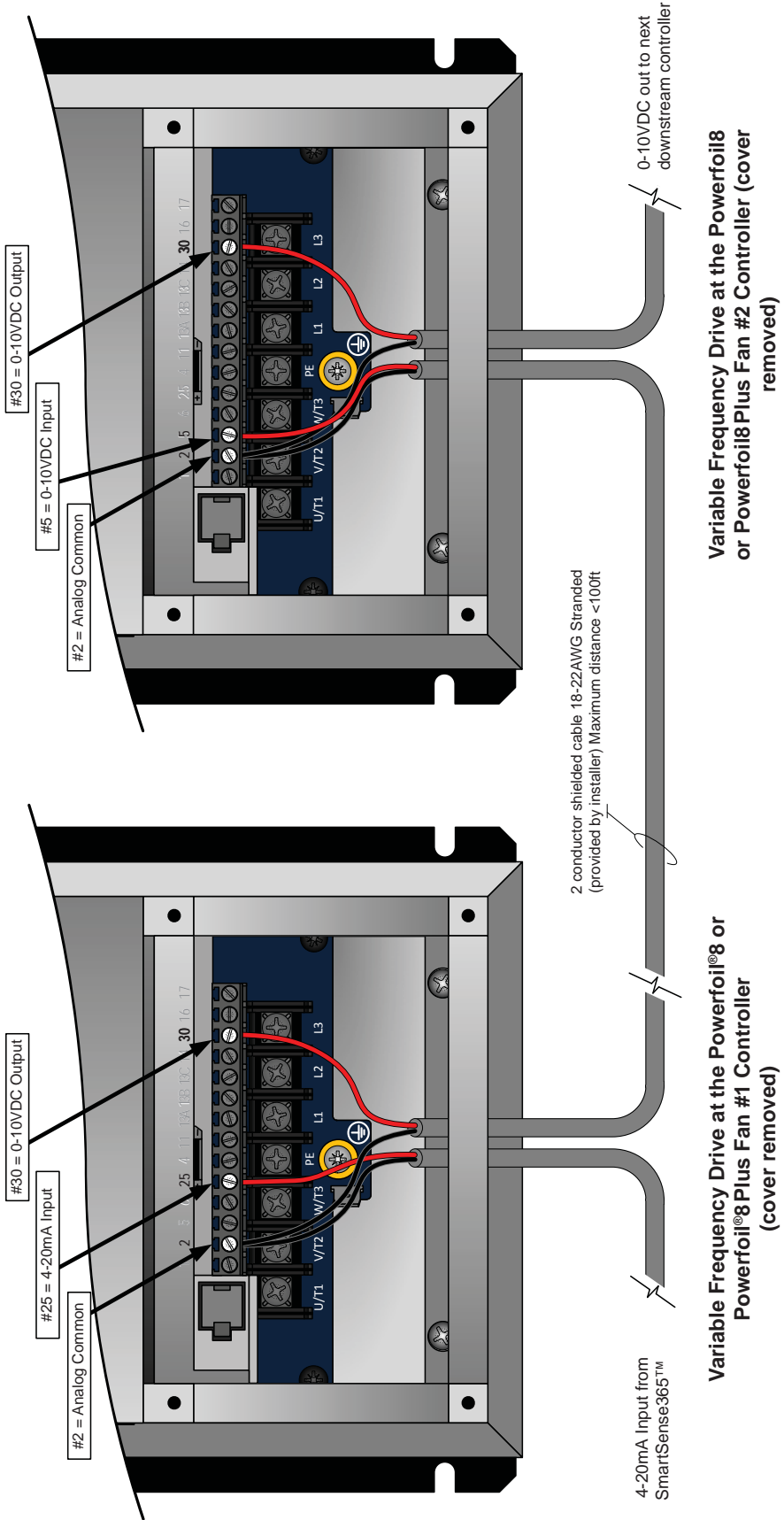

14

Electrical Installation (cont.)

Alternative wiring methods

If there is not a 120VAC receptacle within six (6) feet of the desired SmartSense365™ wall controller location, the installer can extend the cord of the provided power supply as needed or use one of the alternate wiring methods shown below utilizing a 3-conductor shielded cable.

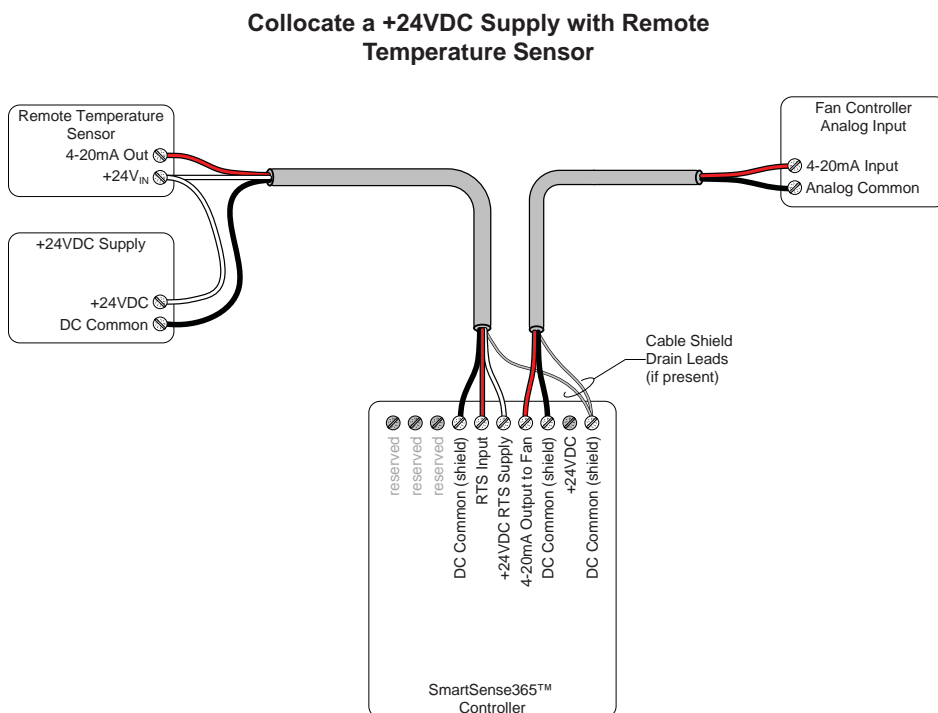
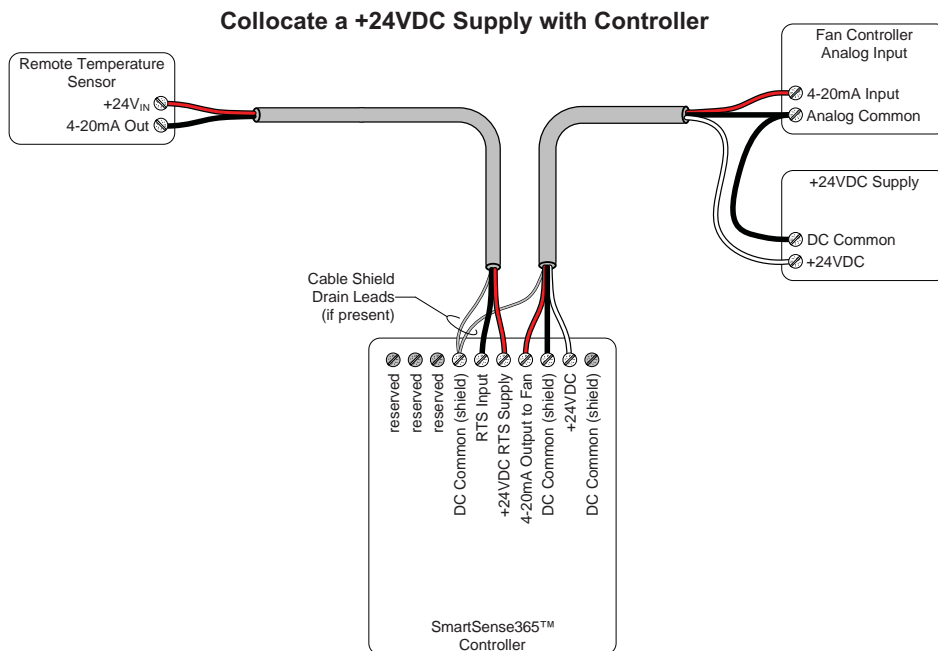

De-stratification is the process by which air is circulated within a space to prevent temperature gradients (stratification) from forming. Depending on the volume of the space and the size of fan used, the minimum fan speed required to de-stratify can vary greatly throughout the day due to a variety of factors. In Winter Mode, the SmartSense365™ is designed to automatically adjust the fan to the optimal low speed by sampling temperature readings at both the ceiling and floor levels. In Summer Mode, the SmartSense365 adjusts fan speed to maintain a user-specified temperature by sampling temperature readings at the floor level only. See the following pages for more information on the modes of operation and to learn how to program your SmartSense365.

Starting and stopping the fan is controlled by the fan wall controller. The SmartSense365 wall controller only provides a speed reference for the fan.

Starting and stopping the fan

Powerfoil®X2.0 and Powerfoil®X2.0Plus fans

The Powerfoil®X2.0 and Powerfoil®X2.0Plus fans are pre-configured at the factory to accept dual control sources. The wall controller keypad allows you to toggle these sources easily using the **LOCAL/REM** button. When the **LOC** indicator is illuminated on the fan's wall controller, the Start, Stop, and Speed functions are controlled solely by the fan's wall controller. When the **REM** indicator is illuminated, the fan speed is controlled by the SmartSense365 wall controller.

To start the fan, press the **RUN** button on the fan wall controller. After starting the fan, switch to **REM** mode to utilize the SmartSense365 wall controller. **To stop the fan**, the **LOCAL/REM** button must be pressed again for **LOC** mode to reactivate the **STOP/RESET** button.



LOC Illuminated



Green **RUN** button active
Red **STOP/RESET** button active
Up and Down arrow buttons active

REM Illuminated





Green **RUN** button disabled
Red **STOP/RESET** button disabled
Up and Down arrow buttons disabled

Powerfoil®8 and Powerfoil®8Plus fans

The fan controller will operate in the same manner as it did prior to installing the SmartSense365.

  The **RUN** and **STOP** buttons are still enabled for fan operation.

  These buttons are now disabled for speed selection.

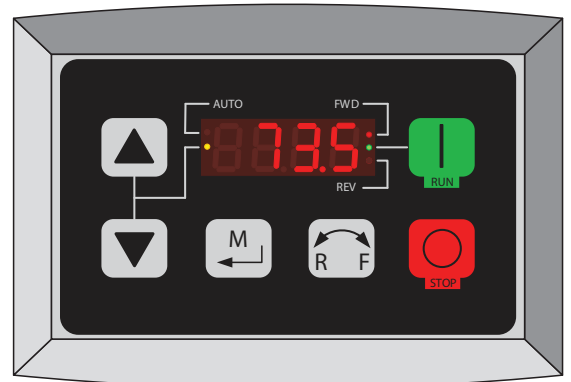

16

Operating the SmartSense365™ (cont.)

Modes of operation

The **Mode** button on the SmartSense365™ controller is responsible for selecting one of the three modes of operation: Winter, Summer, and Manual. When a mode is selected, the corresponding LED illuminates to show it is active.

Note: The maximum speed in Winter Mode is the speed at which the fan is running as fast as possible without creating a draft. In Summer Mode, the maximum winter speed is the minimum summer speed. Any increase in speed beyond that point provides a cooling effect.

Winter Mode

In Winter Mode, the SmartSense365 monitors the difference in temperatures at the floor and ceiling levels, i.e., the Delta T. Based on the Delta T of the space, fan speed automatically adjusts to maintain a uniform temperature between the floor and ceiling (full destratification) while using the lowest fan speed possible to further reduce energy consumption and increase HVAC equipment efficiency (if present).

Summer Mode

In Summer Mode, the SmartSense365 monitors only the temperature at the floor level. Based on this reading, fan speed adjusts according to the user-defined temperature and speed setting. See the following page for programming instructions.

Below are two examples of how the SmartSense365 can be programmed. In Example 1, the maximum winter fan speed is limited to 30%. The summer minimum speed temperature is set to 65°F. When the floor temperature exceeds 65°F, the fan speed will increase (starting at winter maximum) proportionally with the temperature. The summer maximum speed temperature is set to 85°F, which is the temperature at which the fan will reach full speed.

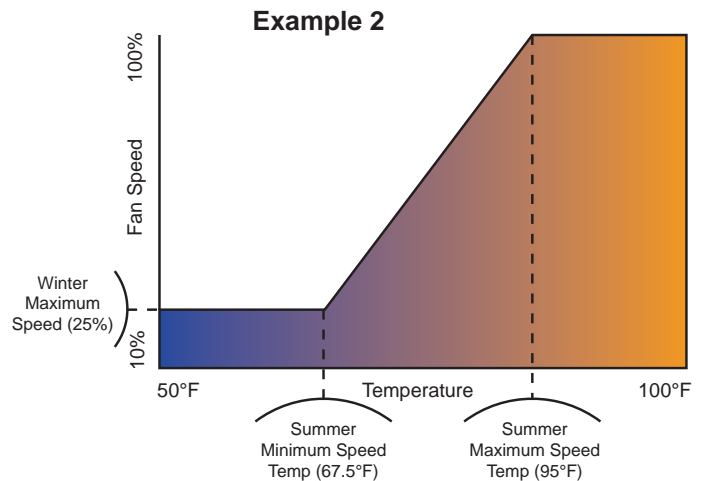
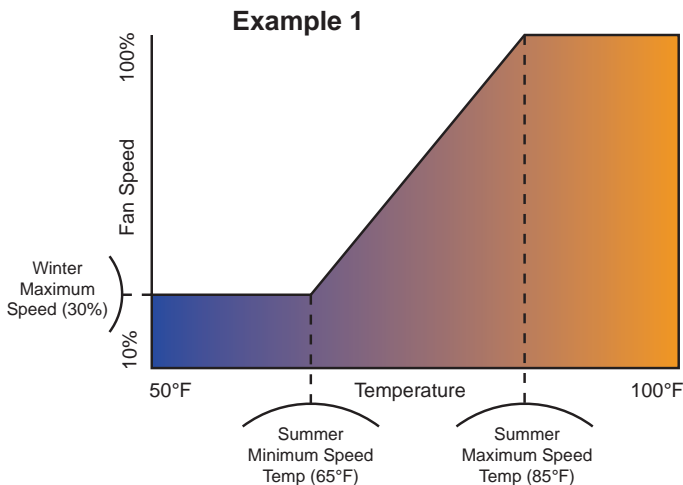

Manual Mode

In Manual mode, you can manually change the speed of the fan to suit your needs by pressing the Up or Down arrow buttons.

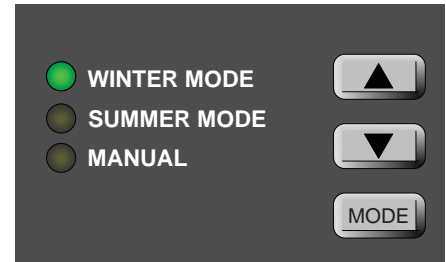

Selecting a mode

To select a mode, repeatedly press the **Mode** button until the green Winter Mode LED, red Summer Mode LED, or yellow Manual LED is illuminated.

Programming Winter Mode maximum fan speed

To program the maximum fan speed for Winter Mode:

1. After selecting Winter Mode, press and hold the **Mode** button for three (3) seconds. The Winter Mode LED will flash.
2. Press the Up and Down arrow buttons to adjust the fan speed until a breeze can barely be felt. It is recommended that the speed be reduced from this point by 5%. The goal is to find the maximum allowable speed of the fan that does not produce a wind chill effect or any discomfort.
Note: Each LED on the Maximum Fan Speed Bar represents a 10% increase or decrease in speed adjustment. When two LEDs are simultaneously illuminated, the second LED indicates a 5% increase (e.g., 15%, 25%, 35%, etc.).
3. Press the **Mode** button once to save the Winter Max Speed setting and to exit programming mode. The Winter Mode LED will stop flashing and the Maximum Fan Speed LEDs will show the fan's current speed.

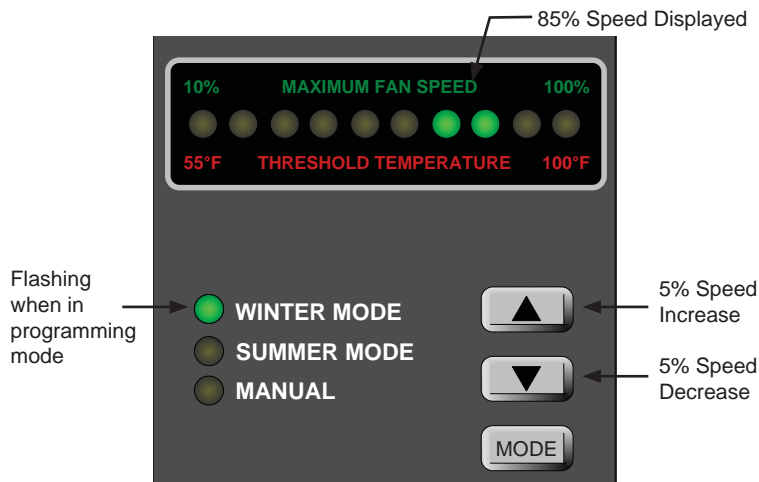

Programming Summer Mode minimum and maximum temperatures

To program the minimum and maximum speed temperatures for Summer Mode:

1. After selecting Summer Mode, press and hold the **Mode** button for three (3) seconds. The Summer Mode LED will flash.
2. To set the Minimum Speed Temperature, press the Up and Down arrow buttons to adjust the minimum speed temperature. Each press of an arrow button changes the setting in 2.5°F increments.
Note: Each LED on the Threshold Temperature Bar indicates a 5°F increase or decrease in temperature adjustment. When two LEDs are simultaneously illuminated, the second LED indicates 5° (e.g., 62.5°, 67.5°, 72.5°, etc.).
3. Press the **Mode** button once to save the Summer Minimum Speed Temperature. The Summer Mode LED will flash, indicating that the SmartSense365™ is ready to accept a Maximum Speed Temperature.
4. To set the Maximum Speed Temperature, press the Up and Down arrow buttons to adjust the maximum speed temperature. Each press of an arrow button changes the setting in 2.5°F increments.
5. Press the **Mode** button once to save the Summer Maximum Speed Temperature. The Summer Mode LED will stop flashing and the Threshold Temperature LEDs will show the fan's current speed.

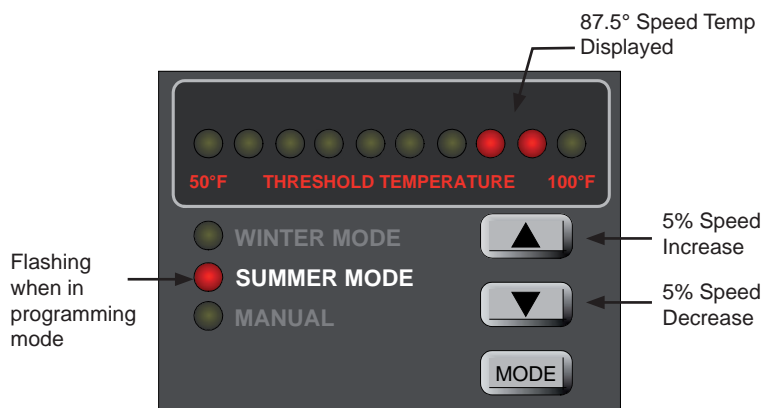

Adjusting Manual Mode fan speed

To manually adjust the fan speed, select Manual Mode, and then press the Up and Down arrow buttons to adjust the fan speed between 10% and 100% as desired.

⚠ CAUTION: Remove power from the SmartSense365™ prior to disconnecting or connecting any portion of the associated wiring when performing any of the procedures below.

During operation, the fan controller keypad display will typically show the command frequency from the SmartSense365 wall controller. If the display reports the error code shown below accompanied by fan shutdown or slowdown, one of the following conditions has occurred:

- The 4–20mA loop circuit between the fan controller and the SmartSense365 wall controller has failed. Remove system power and check for short circuits and/or open circuit conditions. See below for more information.
- The SmartSense365 wall controller power has been removed during normal operation. Check +24VDC power supply and associated connections.
- Component failure at the SmartSense365 or at the fan controller. See below for more information.

**Powerfoil®X2.0 or Powerfoil®X2.0Plus
Fan Keypad “Analog Error”**



**Powerfoil®8 or Powerfoil®8Plus
Fan Keypad “4–20 mA Signal Loss” Error**

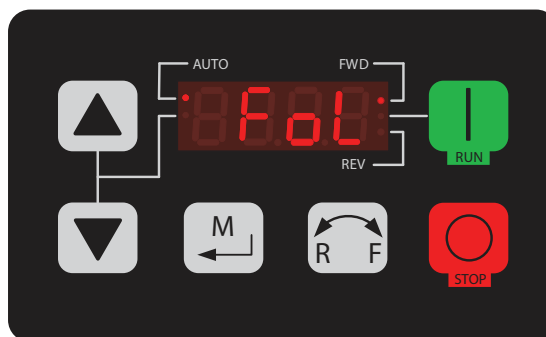

Wall controller

Checking output circuit continuity

The analog current input on the fan controller has an input impedance of 250 ohms. Measure this value at the analog input terminals of the fan controller (terminals ACM-ACI).

Remove the “4–20mA output” wires at the SmartSense365 wall controller, and then measure the same 250-ohm input impedance plus the resistance of the cable used for installation on the output circuit wiring.

Checking output circuit current

The SmartSense365 wall controller provides a 4–20mA current to the fan controller for speed reference.

To check the output circuit current, remove power from the SmartSense365 wall controller. Place a multi-meter (set to mA DC) in line with one of the mA output conductors. Reapply power. Set the SmartSense365 to Manual Mode. The loop current should be between 4mA–20mA in accordance with the speed adjustment buttons on the SmartSense365 keypad.

Remote temperature sensor

Checking output circuit current

Because the load impedance of the remote temperature sensor is in excess of 1 Mohm, the best way to test the remote temperature sensor is to measure the mA signal from the sensor while the system is in operation.

Remove power. Place a multi-meter (set to mA DC) in line with one of the remote’s conductors. Reapply power. The remote temperature sensor signal should read between 4–20mADC. This reading can be converted to degrees Fahrenheit using the following formula:

$$\text{Degrees F} = 18.7 \times \text{mA} - 74$$

$$\text{Example: } 86^{\circ}\text{F} = 18.7 \times 8.55\text{mA} - 74$$



1001240101

REV E

 **BIG ASS FANS[®]**

2348 Innovation Drive Lexington, KY 40511 1-877-BIG-FANS