



SmartSource[®] Series Installation and Operations Guide

January 2017

4326 9562-008

© 2017 Digital Check Corp.
All rights reserved.

NO WARRANTIES OF ANY NATURE ARE EXTENDED BY THIS DOCUMENT. Any product or related information described herein is only furnished pursuant and subject to the terms and conditions of a duly executed agreement to purchase or lease equipment or to license software. The only warranties made by Digital Check Corp., if any, with respect to the products described in this document are set forth in such agreement. Digital Check cannot accept any financial or other responsibility that may be the result of your use of the information in this document or software material, including direct, special, or consequential damages.

You should be very careful to ensure that the use of this information and/or software material complies with the laws, rules, and regulations of the jurisdictions with respect to which it is used.

The information contained herein is subject to change without notice. Revisions may be issued to advise of such changes and/or additions.

Notice to U.S. Government End Users: This is commercial computer software or hardware documentation developed at private expense. Use, reproduction, or disclosure by the Government is subject to the terms of Digital Check standard commercial license for the products, and where applicable, the restricted/limited rights provisions of the contract data rights clauses.

FCC Statement

The statement below is included in this document to comply with a Federal Communications Commission (FCC) regulation. The FCC is an agency of the United States government; thus, the statement below applies to computing equipment installed in the United States of America. Digital Check is taking appropriate steps to be in compliance with FCC regulations and similar regulations of other countries.

Note: This equipment has been tested and found to comply with the limits for a Class A digital device, pursuant to part 15 of the FCC Rules. These limits are designed to provide reasonable protection against harmful interference in a residential installation. This equipment generates, uses and can radiate radio frequency energy and, if not installed and used in accordance with the instructions, may cause harmful interference to radio communications. However, there is no guarantee that interference will not occur in a particular installation. If this equipment does cause harmful interference to radio or television reception, which can be determined by turning the equipment off and on, the user is encouraged to try to correct the interference by one or more of the following measures:

- Reorient or relocate the receiving antenna.
- Increase the separation between the equipment and receiver.
- Connect the equipment into an outlet on a circuit different from that to which the receiver is connected.
- Consult the dealer or an experienced radio/TV technician for help.

Caution

Changes or modifications not expressly approved by Digital Check could void your authority to operate this equipment.

Canadian Regulatory Label

CAN ICES-3 (A)/NMB-3(A)

Contents

Section 1	Setting up the Unit	1-1
	Select a Place for the Unit	1-1
	Need Help?	1-2
	Unpack the Box and Check for These Items!	1-3
	SmartSource Value, Professional, and Expert Units	1-4
	Install the Floor Extender	1-5
	Install the Franker Option.....	1-5
	Install the Inkjet Cartridge Option.....	1-5
	Inkjet Cartridge Capacity.....	1-6
	Connect the Cables.....	1-6
	Value and Professional Units	1-7
	Expert Units	1-8
Section 2	Operating the Unit.....	2-1
	Power On and Off	2-1
	Status Lights	2-2
	Expert LCD Display.....	2-3
	Set Up for Document Flow.....	2-3
	Adjust the Check Limiter (Professional and Expert Units).....	2-4
	Remove the Covers	2-5
	Adjust the Endorser Height	2-6
	Document Preparation	2-9
	Align Checks for Loading	2-11
	Inserting Documents (Professional and Expert Units)	2-12
	Processing Documents – Professional and Expert Units (Document Flow)	2-14
	Start/Stop Button (Professional and Expert Units).....	2-14
	Inserting Documents (Value Units)	2-15
	Remove Items from Pocket and Check Work (All Units)	2-16
	Stopped Document in Track Conditions	2-16
	Clearing Stopped Items in Track.....	2-17
	Using the Start/Stop Button to Move Stopped Items to a Pocket (Professional and Expert Units).....	2-18
	Manually Removing Stopped Items from the Track (All Units)	2-19
Section 3	Cleaning the Unit.....	3-1
	Cleaning Supplies	3-2
	Detailed Cleaning Sequence	3-3
	Turn Unit Off.....	3-4
	Remove Inner and Outer Covers	3-5

	Remove Front Image Camera “Removable Wall”	3-5
	Remove Franker Roller (if Present) and Rear Image Camera “Removable Wall”	3-7
	Clean Rear Image Camera “Removable Wall” (and, if Necessary, Replace Ink Pad).....	3-8
	Remove Staples, Paper Clips, and Visible Debris from the Track.....	3-9
	Blow Air Along Entire Track (Paper Path) with Micro-duster.....	3-10
	Clean Front and Rear Image Glass and “Fixed” Rear Image Camera Wall.....	3-11
	Clean Ink off the Endorser Cartridge and Cartridge Housing.....	3-13
Section 4	Ordering Replacement Items.....	4-1
Section 5	Solving Problems	5-1
	Paper Clip/Staples/Debris in Track.....	5-3
	Document Double-Feeds Increase.....	5-4
	All Problems.....	5-5
	Power Supply	5-5
	Communications/Connections	5-5
	Communications/Connections (continued)	5-6
	Unusual Noises	5-6
	Indicators/Controls	5-7
	Jams or Unexpected Paper Stops	5-7
	Feeder	5-8
	Feeder (continued).....	5-9
	Feeder (continued).....	5-10
	Reader	5-11
	Image	5-12
	Endorser.....	5-13
	Endorser (continued).....	5-14
	Pockets	5-15
	LCD Display (Expert Units)	5-15
	Parts.....	5-16

Tables

Table 3-1 Cleaning Supplies for Rapid and Detailed Cleaning 3-2
Table 3-2 SmartSource Series Cleaning Kit 3-2
Table 3-3 SmartSource Series Starter Kit 3-3
Table 4-1 Replacement Items..... 4-2

Tables

This page intentionally blank

Section 1

Setting up the Unit

Select a Place for the Unit

- Indoor only
- Flat, stable surface
- Clearance
 - At front, to load and remove documents.
 - Above, to remove covers and access the track.
 - Between the sides of the unit and a monitor (if the unit is located next to a monitor) to reduce interference with the magnetic ink character recognition (MICR) reader inside the unit.
 - At rear, to:
 - Turn the unit on.
 - Connect the power cord (from the power supply), the USB interface cable, and protect those connections.
- Near PC or network connection
- Near an AC power outlet
- Adequate ventilation
- Away from water/moisture/high humidity, heat/direct sunlight, dust
 - Operating temperature: 0 to 35° C (32 to 95° F)
 - Storage temperature: -20 to 60° C (-4 to 140° F)
 - Shipping temperature: -40 to 65° C (-40 to 149° F)
 - Operating humidity: 10% to 85% (non-condensing)
 - Storage humidity: 5% to 95% (non-condensing)

Notes:

- SmartSource Professional and Value units draw a maximum of 48 watts of power, and Expert units draw a maximum of 60 watts of power from a 100 to 240 VAC, 50/60 Hz outlet. All units draw 2.0 amps (maximum) of current from the included 24 VDC power supply.
- Each unit must be operated with Digital Check power supply 75-0580-904 and no other.

Caution

The SmartSource unit may be susceptible to “burst” or “electrical fast transient” (EFT) noise entering the unit through the power cord. These types of noise signals are caused by large electrical equipment (such as heating and cooling units) connected to nearby electrical outlets. Burst or EFT noise may cause the SmartSource to stop functioning, requiring the operator to restart the SmartSource and its application(s).

If this occurs,







- Plug the SmartSource into an electrical outlet on a different branch of the power distribution system where large electrical equipment is not connected to nearby outlets.
- Plug the SmartSource into a line conditioning device or an uninterruptible power source (available from Digital Check supplies).

Need Help?

Digital Check Help Desk 1-847-446-2285

- Digital Check on the worldwide web (for general product information and training videos) www.digitalcheck.com
- Digital Check supplies and replacement items
www.digitalcheck.com

Unpack the Box and Check for These Items!

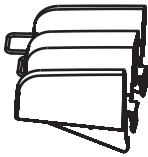
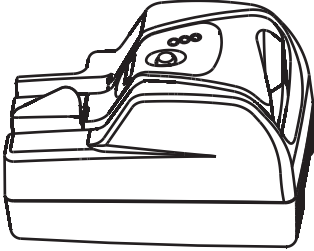
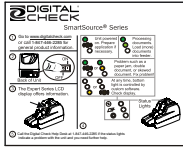
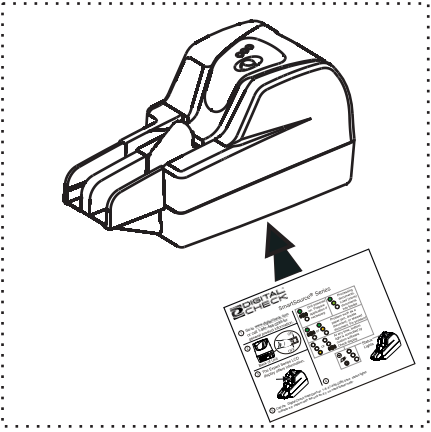
<p>USB or Ethernet Cable</p> 	<p>! Do not plug a USB cable into unit/PC yet! Check with manager/administrator! Software must be loaded on PC before a USB cable can be connected!</p>
<p>AC Power Cord</p> 	<p>Check Scanner Cleaning Card</p> 
<p>Power Supply</p> 	
<p>Inkjet Print Cartridge (option)</p> 	<p>Franger Roller (option)</p> 
<p>Pocket Floor Extender</p>  <p>SmartSource® Series</p> 	<p>Reference Card</p>  <p>Store card under unit.</p> 

SmartSource Value, Professional, and Expert Units

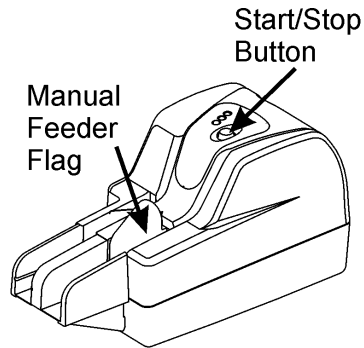

Early Professional

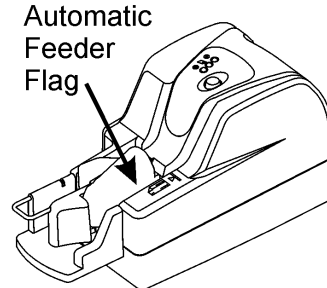

Current Professional

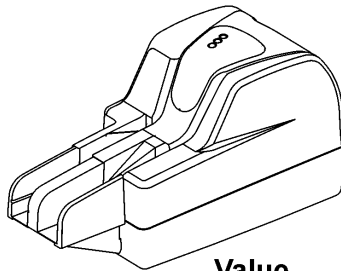

Value

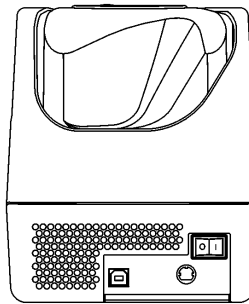

**Back of Unit
(Value and All Professional Units)**

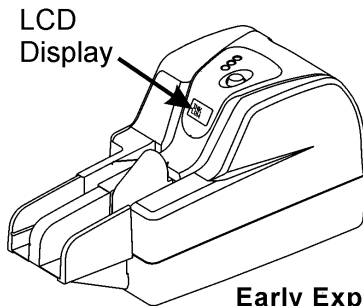

Early Expert

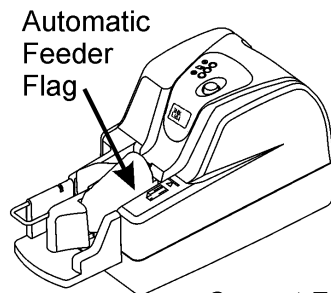

Current Expert

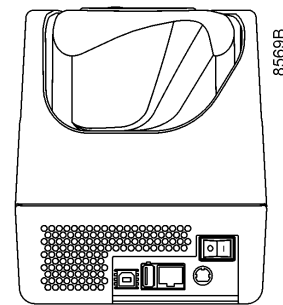

Back of Unit (Expert)

Install the Floor Extender

Note: The Value and early Professional and Expert units have separate floor extenders that must be installed when the unit is received. Open Professional and Open Expert units are shipped with a permanently attached floor extender that does not require this assembly.

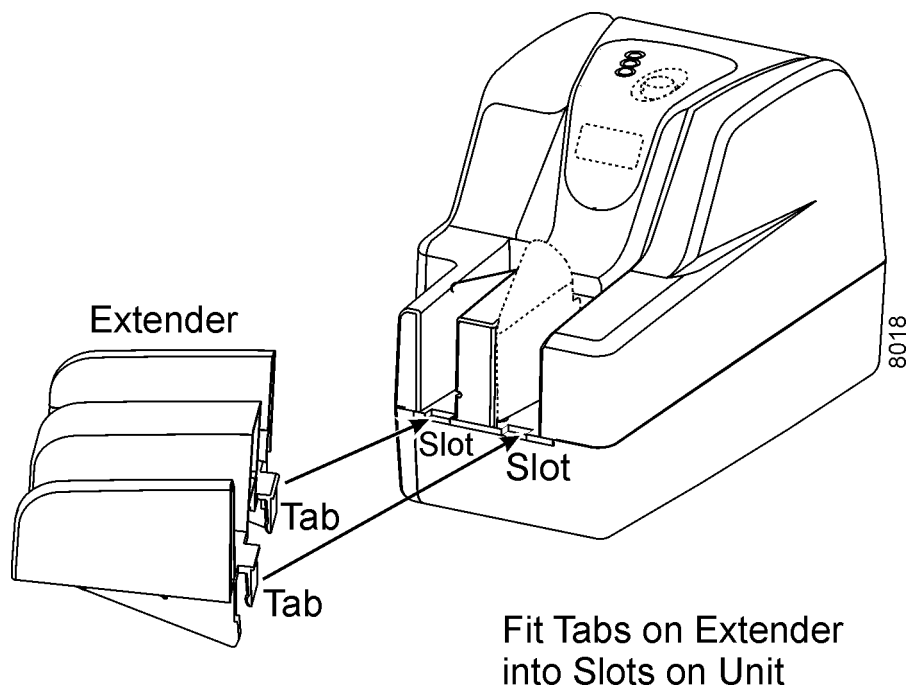

Install the Franker Option

Use the instructions provided with the Franker shipping container.

Install the Inkjet Cartridge Option

To install the ink cartridge, use the instructions packed next to the Inkjet Cartridge pouch in the unit shipping box.

For additional/replacement cartridges, order the Inkjet Cartridge (82-2120-984) from Digital Check (see Section 4 of this guide).

Inkjet Cartridge Capacity

The operational life of the inkjet cartridge varies with

- Endorsement application parameters
 - Number of endorsement lines per document
 - Number of characters printed per line
- Character font selection
- Print quality settings
- Printing of graphics and/or logos
- Document batch size

The capacity of the inkjet cartridge can range from approximately 1,300,000 up to 5,300,000 characters depending on the operational settings and workflow. It is recommended that the cartridge capacity be tested by the user in the actual print environment to determine actual usage.

Connect the Cables

Follow these steps to connect the cables to the unit. Refer to the following figures.

1. **Turn the unit OFF**
2. Connect the power supply cable to the unit
3. Connect the AC power cord to the power supply
4. Plug the AC power cord into an outlet
5. **Load the software and drivers on the PC**

Note: *The unit software and drivers must be loaded on the PC before connecting the USB (or Ethernet) cable from the unit to the PC*

6. Connect the USB (or Ethernet) cable
7. **Turn the unit ON**

After the cables have been connected and the software has been installed on the PC, the unit is now ready for operation.

Value and Professional Units

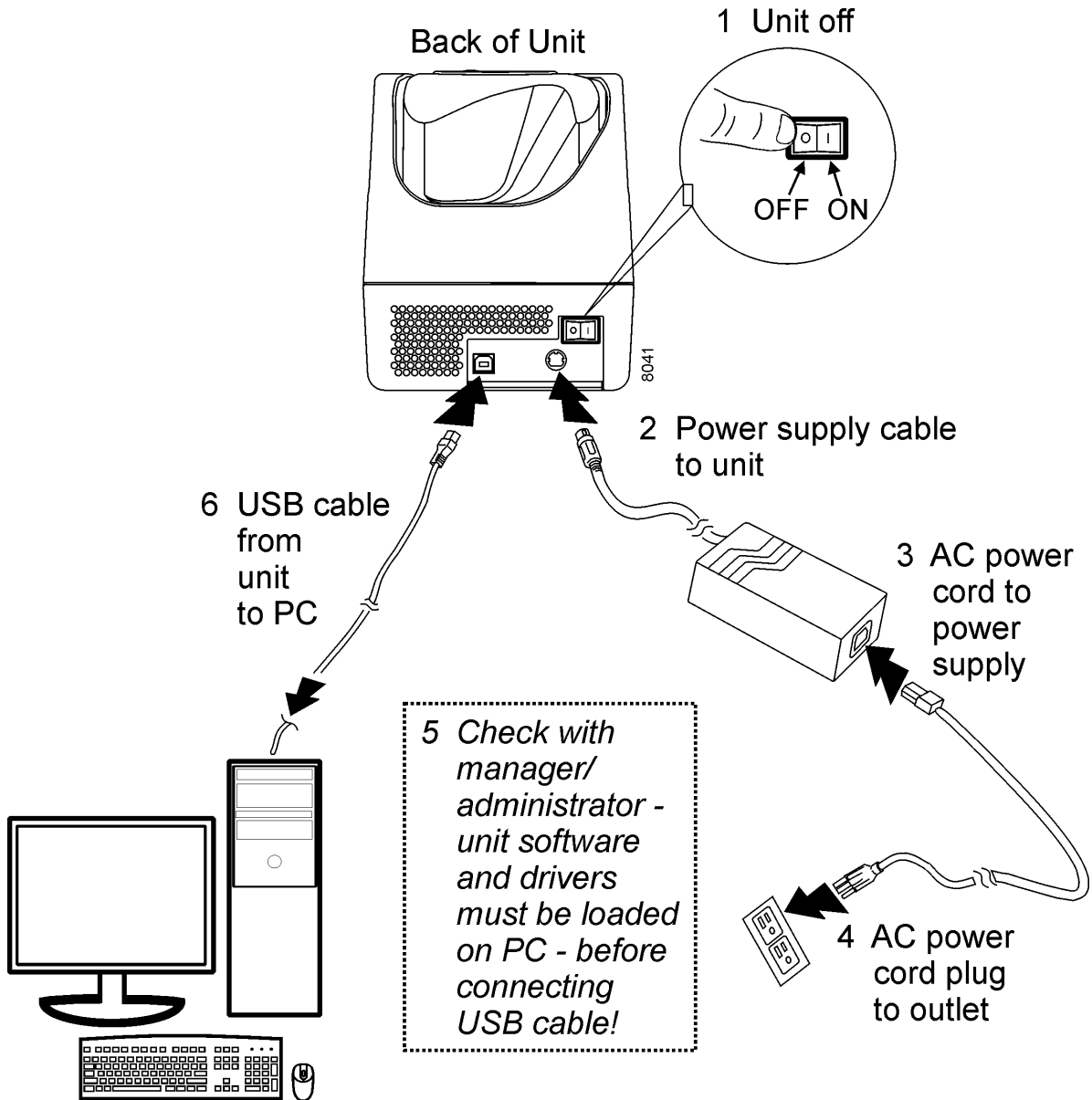

Expert Units

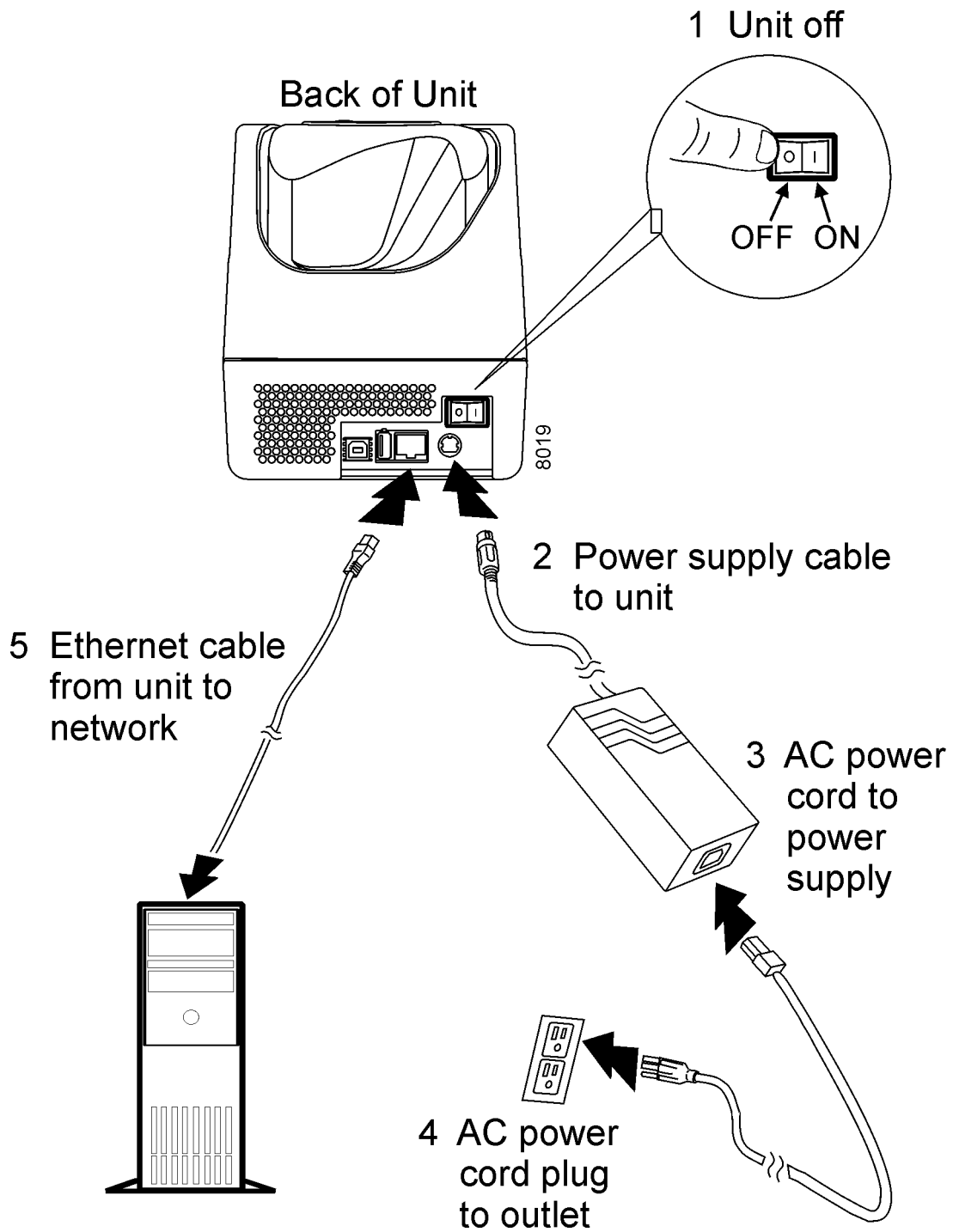

Section 2

Operating the Unit

Power On and Off

1. Turn the unit ON or OFF using the switch on the back of the unit.
 - a. Press "I" on the power switch to turn the unit ON.
 - b. Press "O" on the power switch to turn the unit OFF.

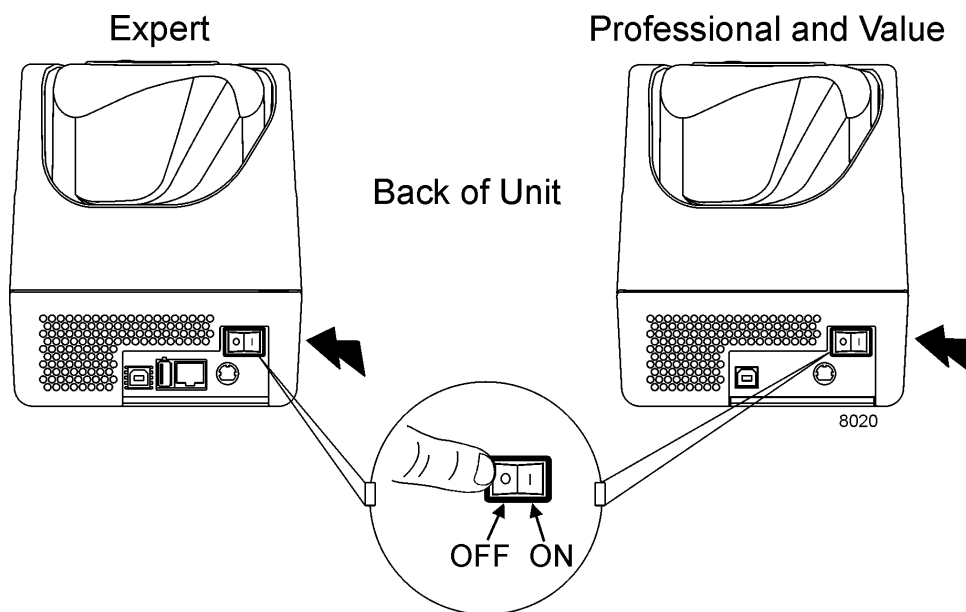

2. When the unit is turned on, there should be a green light on the power supply.
3. The top status light on the unit should be solid green and the middle status light should blink lighter green. Refer to Section 5 if a problem occurs.

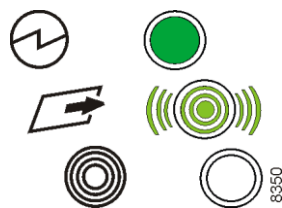

Status Lights

Three lights on the top of the unit indicate the status of the unit and the software application that runs on the host PC. You should consult your application documentation for information on the meaning of the bottom light, the application status light. When lit, this light is always yellow (solid or blinking).

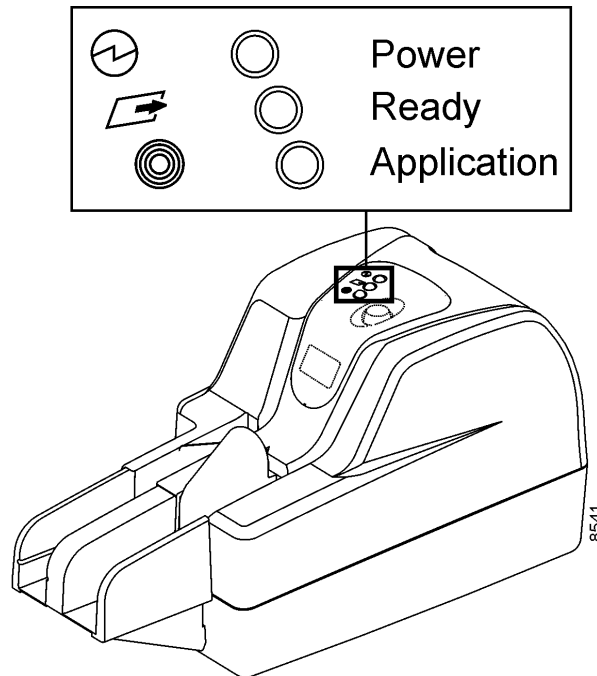

The following table shows the status light colors, patterns/meanings, and operator actions.

Light Pattern	Meaning	Action
	Unit is powered on.	If necessary, prepare application to flow documents.
	Unit is processing documents.	Load (more) documents into feeder bay.
	A problem has occurred (such as a jam, double document, or skewed document in the unit).	Check that documents are within specifications. See "Stopped Document in Track Conditions" later in this section.

8465

Expert LCD Display

The display may provide additional information, depending on your application.

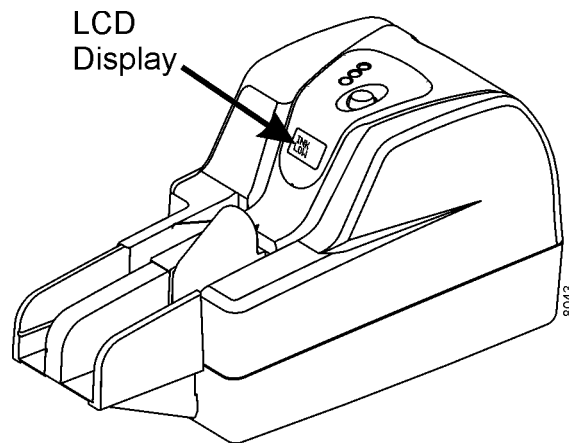

Set Up for Document Flow

When you prepare to process documents, you should

- Adjust the position of the check limiter on Professional and Expert units
- Remove the covers
- Check the height position of the endorser housing
- Replace the covers

Adjust the Check Limiter (Professional and Expert Units)

On Professional and Expert units, adjust the position of the check limiter to match the length of the longest checks or papers in the batch you will process (if the items are longer than the pocket).

Note: *The check limiter is optional on Value units.*

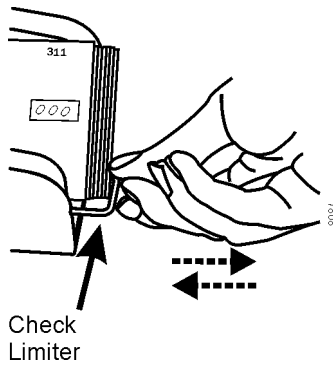

Remove the Covers

All units – Expert, Professional, and Value -- have two top covers, an outer cover and an inner cover.

1. Remove the top inner and outer covers. Grasp each cover and lift it straight up and off the unit.

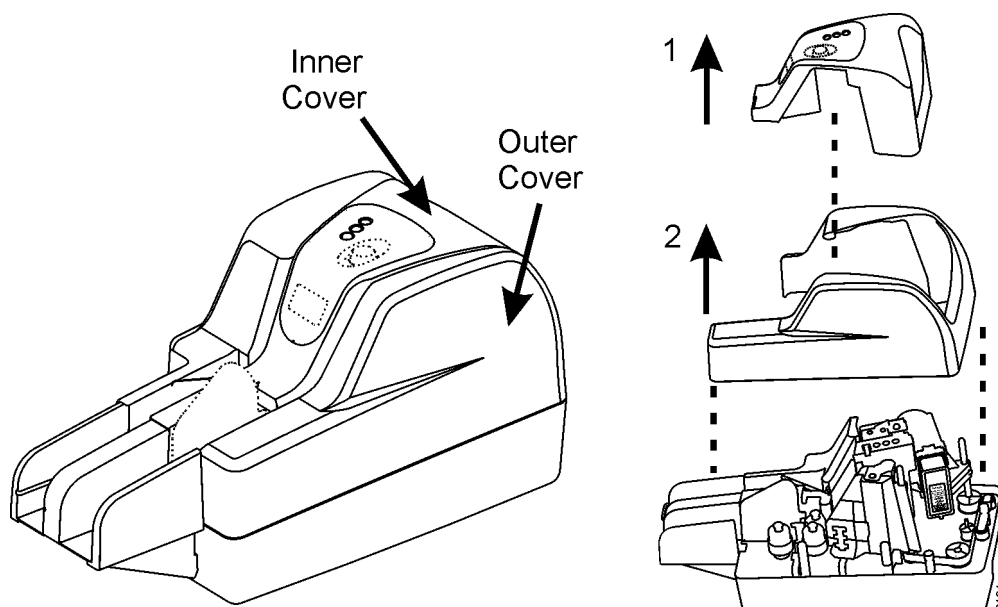

Adjust the Endorser Height

The endorser height can be manually adjusted to one of two (2) print positions.

1. Press the tab toward the cartridge to release it.
2. Slide the ink cartridge housing up or down to the desired height until it clicks into place.

Expert, Value, and Early Professional Units

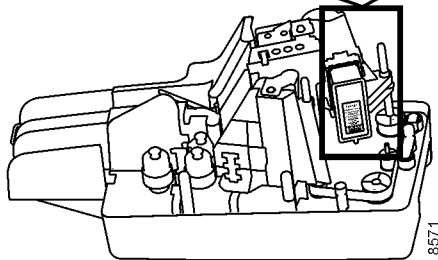
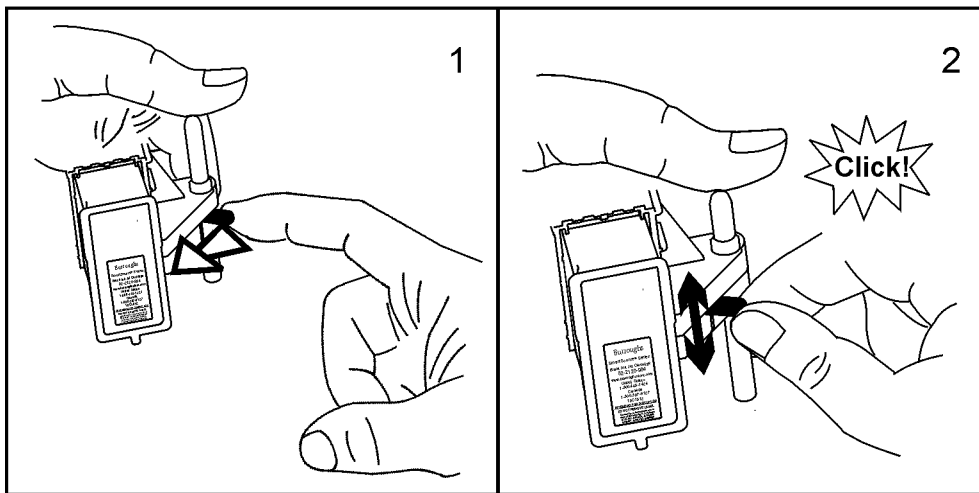

Current Professional Units

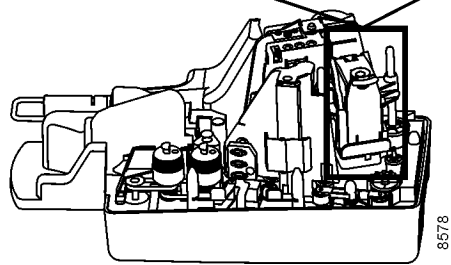
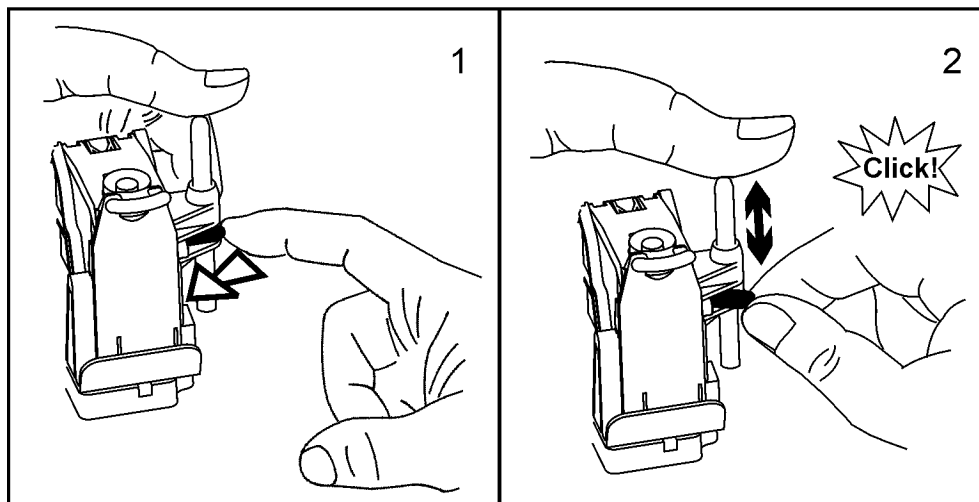

Caution

When processing the smallest documents on Open Professional units, (minimum size for documents is 2.9 in. x 2.0 in.), the endorser top print position is too high to endorse properly. Check that the endorser print position is correct when feeding small documents.

Operating the Unit

3. **On all units, do not** raise the endorser above the top print position. If you do, make sure the endorser cable is pushed back through the slot and underneath the base plate when you move the endorser back to a print position. There should be no loop or bulge in the cable above the base plate.

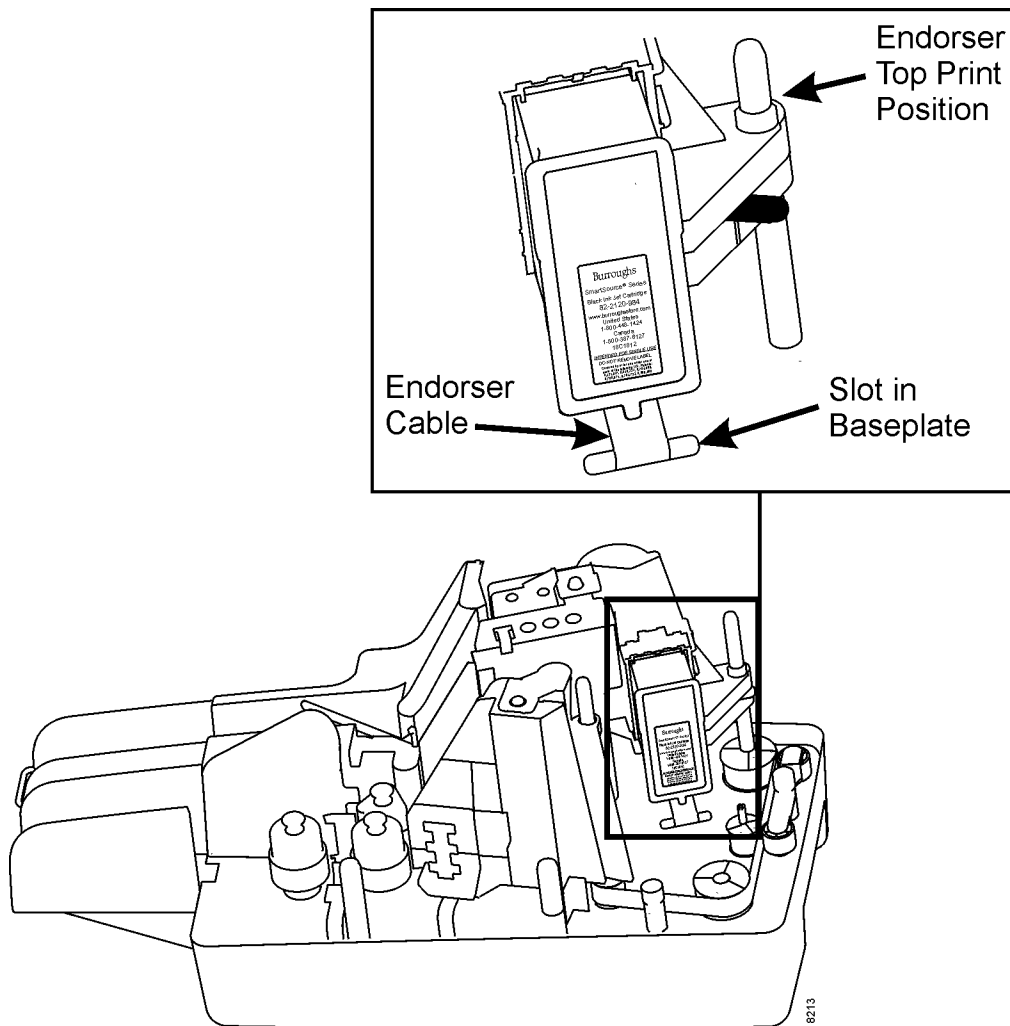

4. Replace the covers, and process one or two documents. Make sure that the endorser print position is at the desired height.

Document Preparation

It is important to properly prepare documents for processing. Otherwise, unit performance may be less than satisfactory. You should review documents for acceptable size and condition, and carefully follow the steps in this section to prepare documents for processing.

- Check for acceptable size.
- Smooth out creases, folds, curls, and dog-ear corners.



- Remove rubber bands, paper clips, staples, or foreign objects.

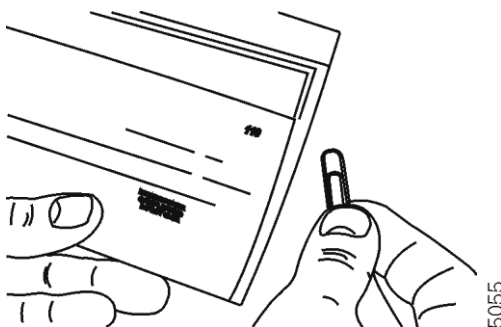

Operating the Unit

- Remove check stubs and adding machine tapes.

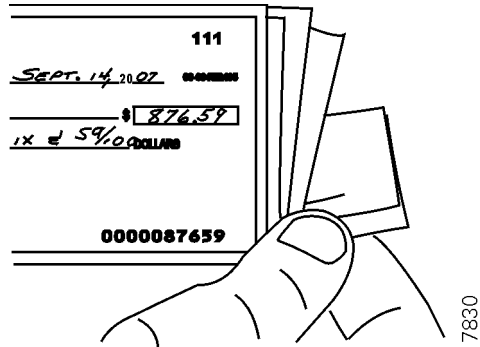

- Repair torn, damaged paper, or place each damaged item in a carrier envelope.

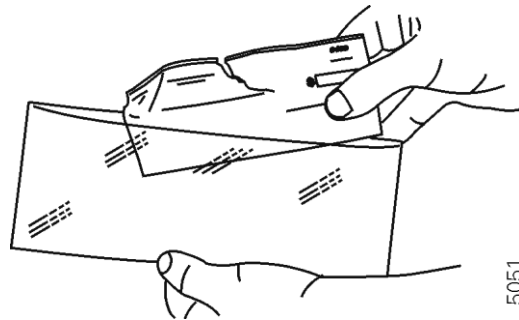

- **Do not** use tape to repair areas with code line or encoded amount information.

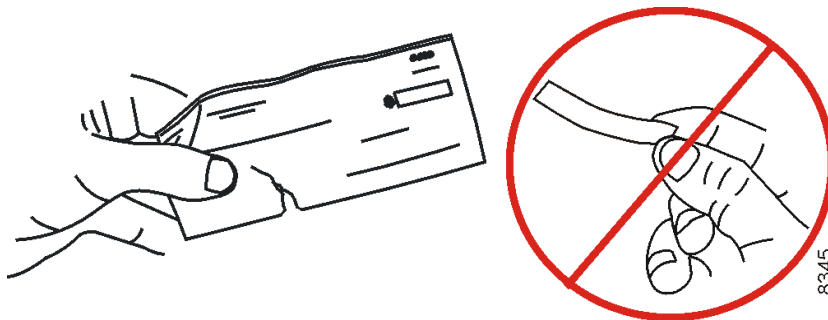

Align Checks for Loading

- On Professional and Expert units, make sure to arrange checks so that printed sides face up, and all face the same direction.
- The date line on checks should be in the upper right corner.

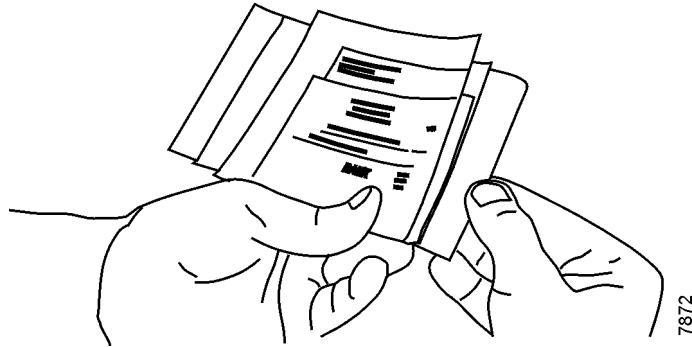

- On Professional and Expert units, align checks on bottom and leading edges.
 - When processing small quantities of documents, tap bottom/leading edges on a hard, flat surface **until the entire bottom and leading edges of the documents are aligned.**
- OR
- When operating in a higher volume, back counter environment, use of a document jogger to align the documents may be desirable.

On Professional and Expert units, the check bottom and leading edges of the stack of items must align for satisfactory document feeding. Alignment of documents is very important, especially when feeding small documents.

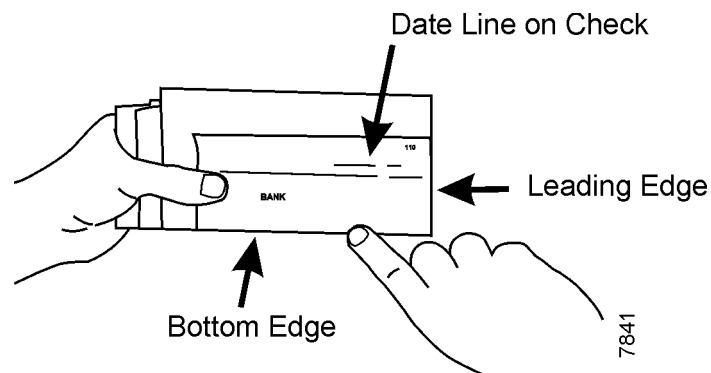

Inserting Documents (Professional and Expert Units)

- Insert items one at a time or in batches that fit easily in the feeder.

Note: Depending on the feeder size ordered, your unit may stop after processing 50 items.

- Wait for two green status lights.

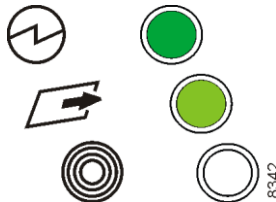

1. On Value and early Profession and Expert units, push the feeder flag back toward the pocket side of the unit.

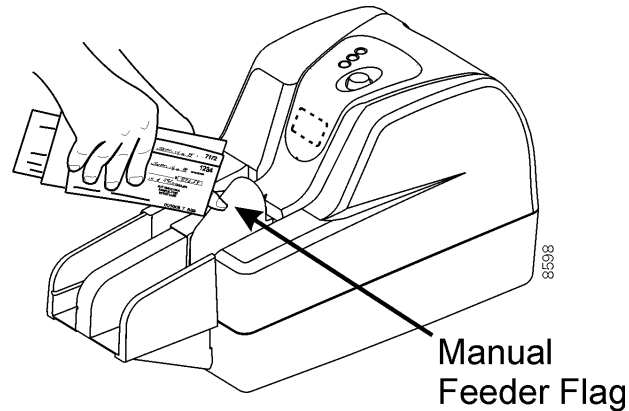

Note: Open Professional units have an automatic flag that is open/automatically positioned toward the center of the unit before the feeder is loaded and document processing begins. You do not have to push the flag back on these units,

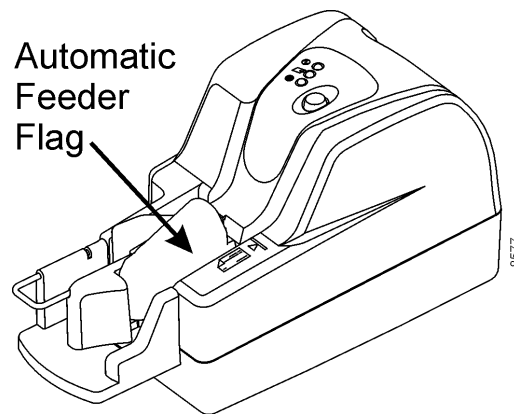

- Slide documents forward to the end of the feeder bay - printed sides face the side of the unit, not the feeder flag.

Caution

If feeding more than one item, do not slide or push items into the unit past the end of the feeder bay.

There is an insertion icon on the outer cover of the unit that shows the location of the end of the feeder bay.

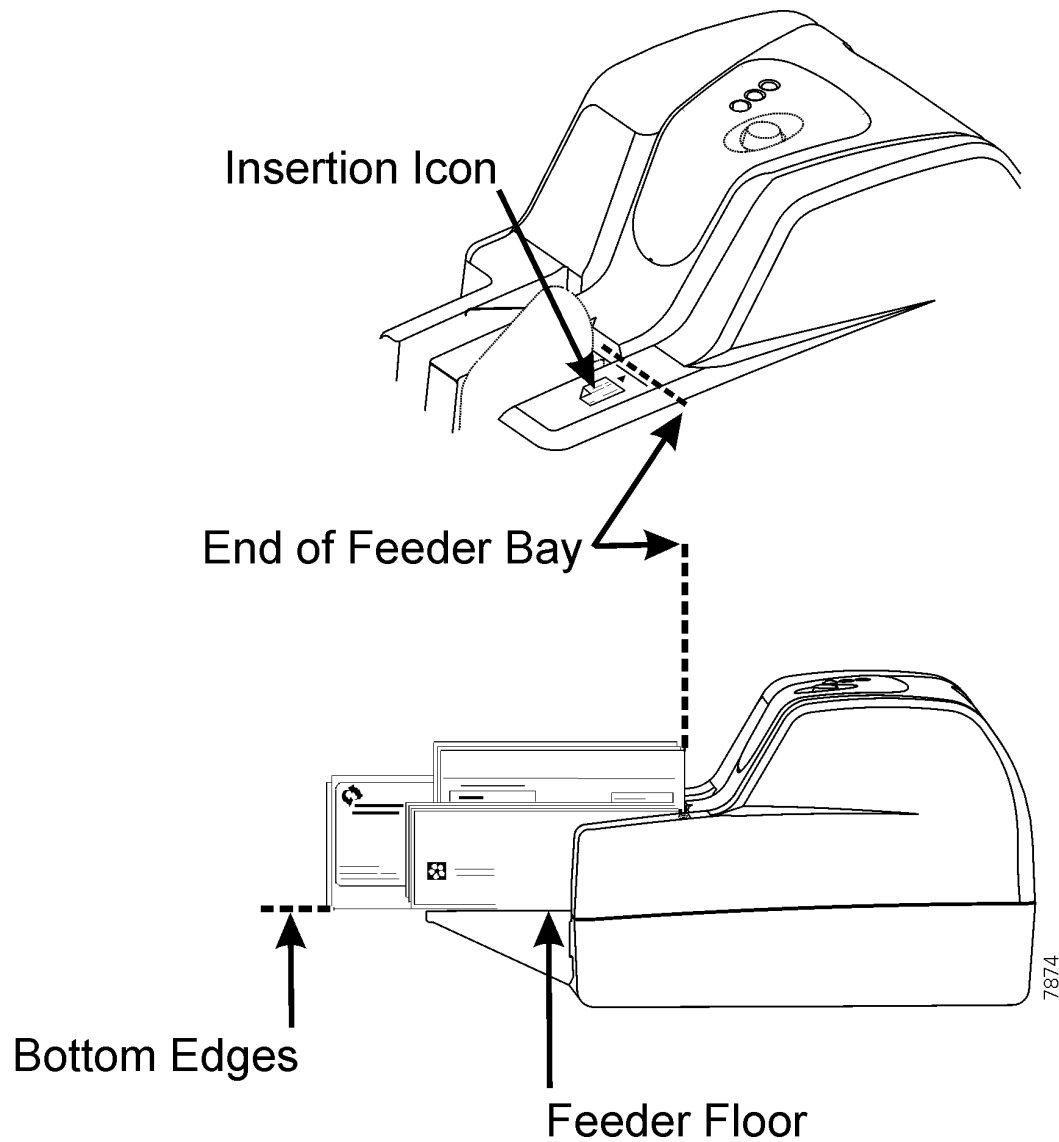

Bottom edges of the documents should touch and be aligned with the feeder floor.

Processing Documents – Professional and Expert Units (Document Flow)

1. To initiate document processing, use either your application software user interface, or press and release the Start/Stop button.

Note: Start/Stop Button functions are dependent on your application. Refer to your application instructions.

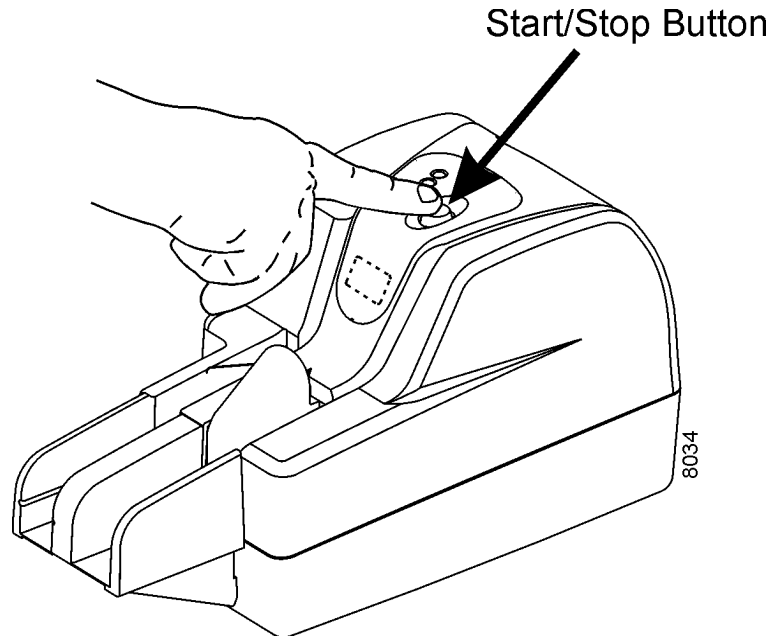

2. If the unit stops after feeding 50 items, the 50 item option is active.
3. To continue running more items, remove the remaining items from the feeder bay. Reinsert the items (and/or additional items) into the feeder bay. Press the Start/Stop button, or use your application software interface to resume document processing.

Start/Stop Button (Professional and Expert Units)

The Start/Stop button initiates document processing. Use the Start/Stop button to:

- Start or stop document flow.
- Restart document flow after a track stop (center status light is amber).
- Clear stopped items in the track. **Hold down the Start/Stop button for three seconds** to move the stopped item(s) in the track to a pocket (“flush the track”).

Inserting Documents (Value Units)

- Wait for two green status lights.

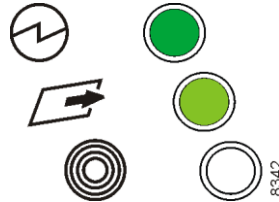

- Insert documents into the feeder bay, one item at a time. Printed sides face the side of the unit, not the feeder flag.
- Slide each document forward into the feeder bay.

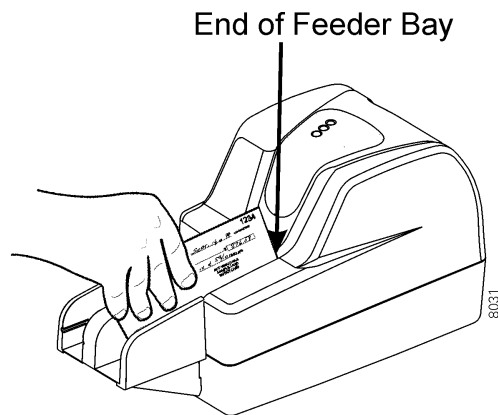

The document bottom edge should touch and be aligned with the feeder floor.

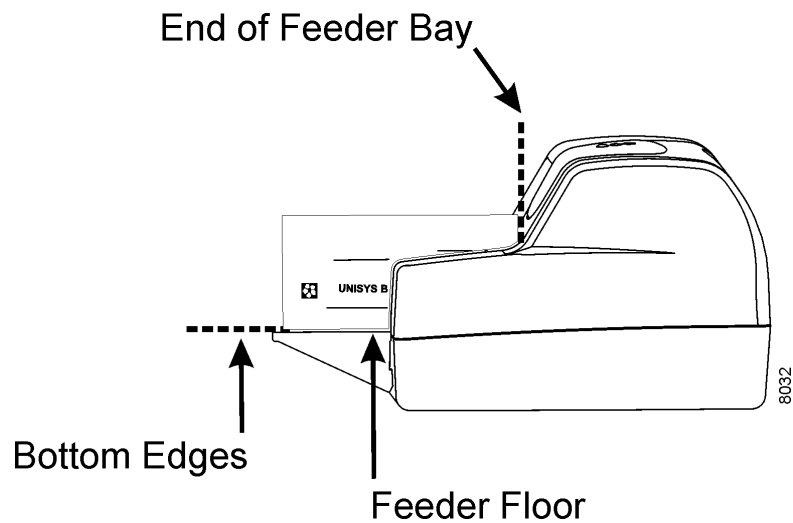

- To run another item, insert another document into the feeder bay as before.

Remove Items from Pocket and Check Work (All Units)

To prevent jams, you should remove items from the pocket when the pocket is nearly full. Pocket capacity is approximately 100 items. Verify that endorsements are clearly printed, and that image quality is acceptable (if the application allows image viewing.)

Stopped Document in Track Conditions

If an item stops in the track, or does not fully enter a pocket, it must be removed from the track before documents can flow again.

Note: *When this happens, you must check your application documentation for information on clearing stopped items and **perform the necessary recovery steps.***

The item may have stopped in the track due to one or more of the following:

- Unacceptable size
- Creases, folds, curls, or dog-ear corners
- Rubber bands, paper clips, staples, or foreign objects
- Check stubs or adding machine tapes
- Torn or damaged paper
- Missing or misaligned inkjet cartridge when endorsement is enabled

Prepare items properly for flow to prevent or minimize document stops in the track. See “Document Preparation” earlier in this section.

If there are repeated problems with documents moving through the track, see Section 5 of this guide, “Jams or Unexpected Document Stops.”

If a document stop or exception condition occurs, check these software utilities (if installed) for additional information:

- Update Monitor (Expert units)
- SmartStats (Professional and Value units)

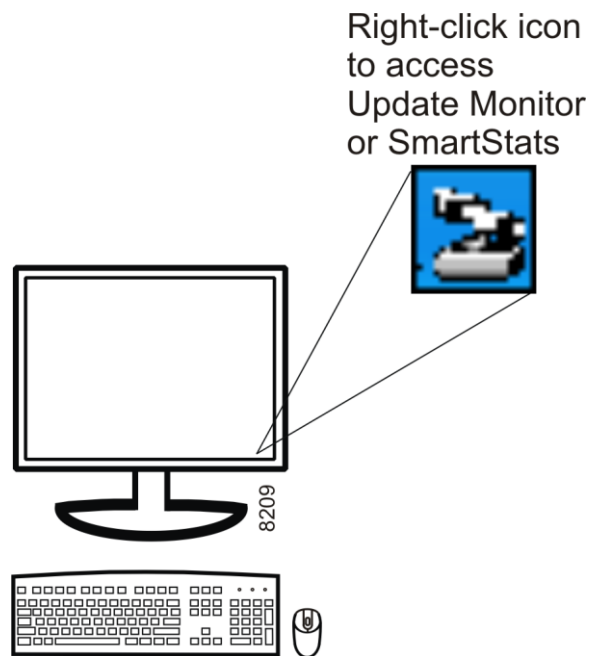

Clearing Stopped Items in Track

When an item stops in the track, there are two methods to clear the track:

- Use the Start/Stop button to move the item to a pocket (Professional and Expert units).
- Manually remove the item from the track (all units).

Using the Start/Stop Button to Move Stopped Items to a Pocket (Professional and Expert Units)

You should first try to flush the stopped item from the track using the **Start/Stop button**.

1. **Press and hold down the Start/Stop button for three (3) seconds** to move the item through the track to the pocket(s). Leave the items in the pocket(s) once the track is cleared.

Note: *Start/Stop Button functions are dependent on your application. Refer to your application instructions.*

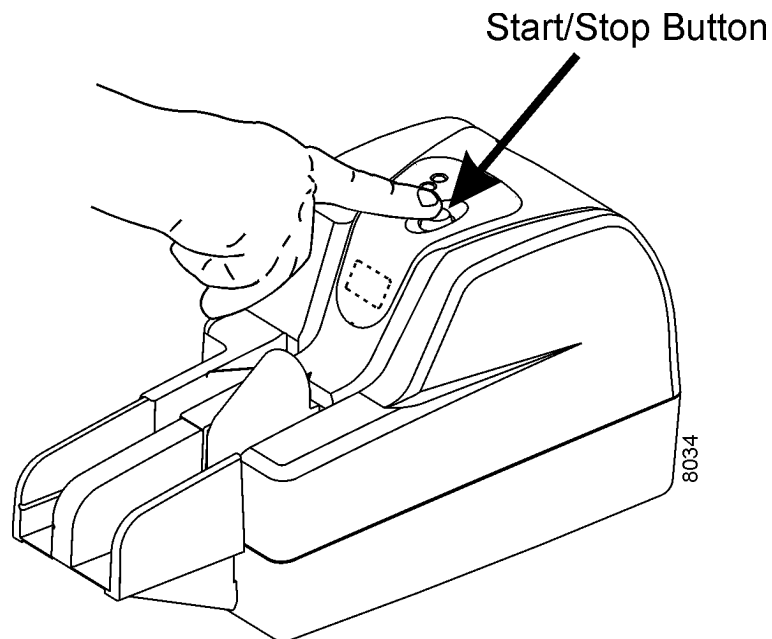

2. **If an item remains in the track after holding down the Start/Stop button for three seconds, you must manually remove the item from the track.** You should be able to remove the stopped items without removing the covers.

Whether you remove covers or not, keep items in the same order in which they were inserted for processing.

Manually Removing Stopped Items from the Track (All Units)

1. Remove items starting at the pocket area first, and work back to the feeder area.

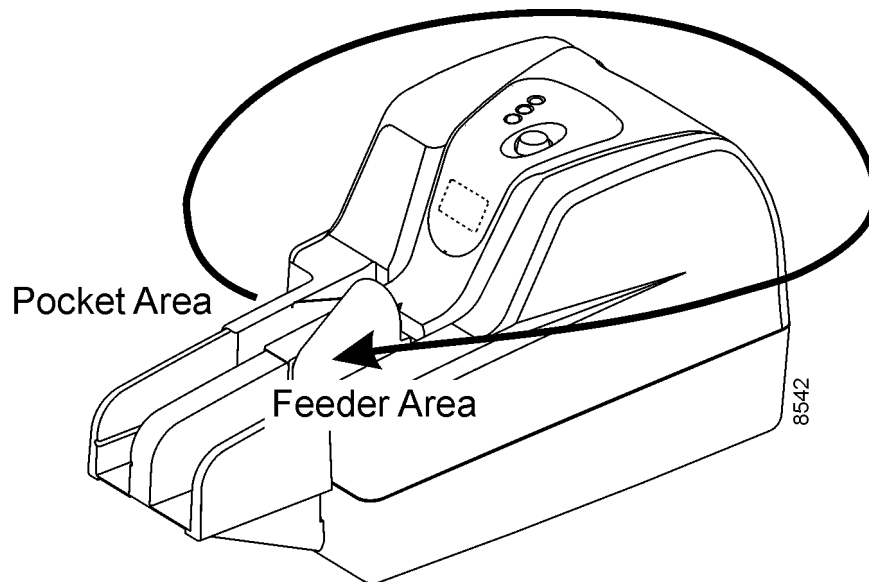

2. To remove items from inside the unit, remove covers if necessary and check the location of the stopped item in the track.
 - a. For items that are stopped on the track on the pocket side, pull the item out toward the back or front of the unit.

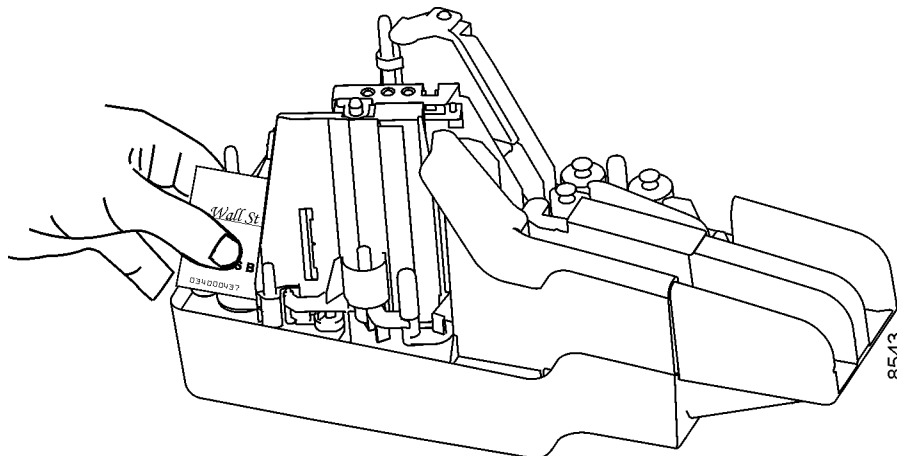

- b. If an item has stopped in the track at the back of the unit, pull it out of the unit.

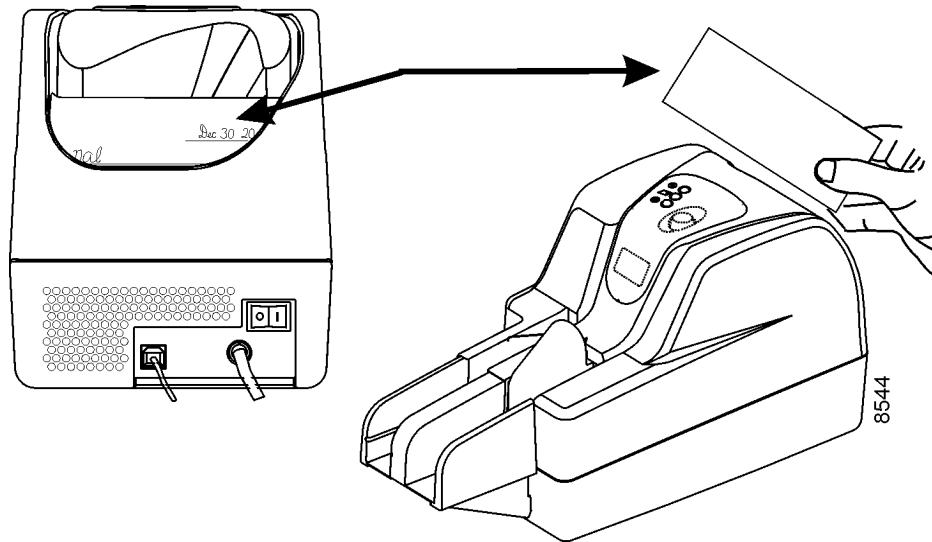

- c. For items stopped on the feeder side of the unit, pull the item out toward the back of the unit.

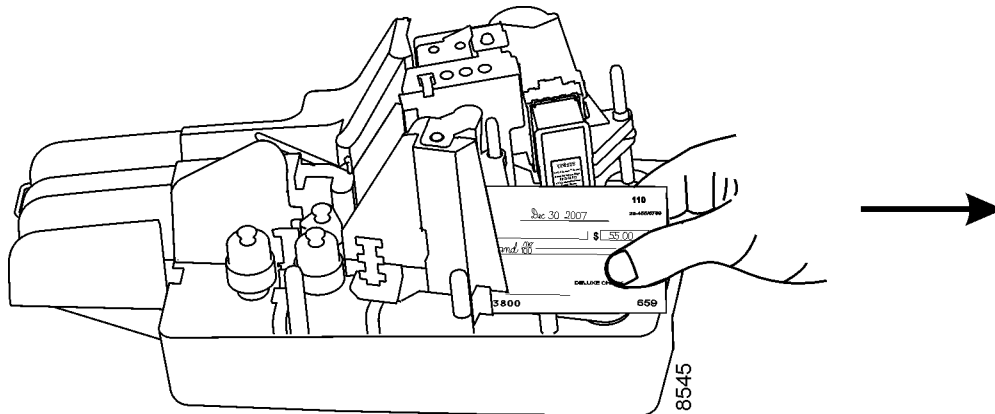

3. Replace the unit covers if they were taken off of the unit to remove items from the track.
4. Consult your application documentation for the necessary recovery steps on reinserting and feeding items that were removed from the unit/track.

Section 3

Cleaning the Unit

Processing of paper documents will, over time, generate debris, such as paper dust, staples, or other foreign matter, that will require operator cleaning in order to maintain peak operating performance of the unit.

The SmartSource has been designed to make cleaning easy to perform, and it is recommended that cleaning operations be performed by the operator on an “as needed” basis.

This section identifies which cleaning procedures are required, illustrates how to properly complete these procedures, and describes the cleaning supplies. Digital Check has available, through the Digital Check Store website, a variety of cleaning supplies and replacement items specifically designed to maintain the SmartSource units.

Two cleaning procedures are recommended for use with the SmartSource product; a “rapid cleaning” and a “detailed cleaning” procedure.

Rapid Cleaning

To perform the rapid cleaning procedure, run the check scanner cleaning card through the unit following the instructions on the card envelope. As the cleaning card travels through the unit it contacts and cleans paper handling surfaces and components inside the unit, without removing the unit covers or track walls.

Using the rapid cleaning procedure saves operator time and may reduce the need to perform the detailed cleaning procedures.

Detailed Cleaning

Detailed cleaning procedures target specific critical components and devices inside the SmartSource unit. Detailed cleaning procedures are implemented when specific performance and/or operational problems occur.

The main areas of the unit that may require detailed cleaning are the following:

- Track (paper path)
- Front and rear image glass
- Rear image camera removable wall
- Fixed rear image camera wall
- Endorser cartridge and cartridge housing

Cleaning Supplies

SmartSource cleaning supplies can be ordered from Digital Check at 1-8047-446-2285, or go to www.digitalcheck.com.

Table 3-1 lists all of the cleaning supplies that are available for the SmartSource.

Table 3-1 Cleaning Supplies for Rapid and Detailed Cleaning

Procedure	Supplies and Description	Supply Order No.
Rapid Cleaning	Check Scanner Cleaning Card (package of 15)	75-7200-995
Detailed Cleaning	Track Clearing Spatula (package of 5)	75-0381-907
	Image Glass Cleaning Pads, pre-saturated with isopropyl alcohol (package of 80)	75-1804-907
	Micro-duster (box of four 10 oz. cans)	75-0501-900
	Cotton Wiping Cloths (6 in. x 6 in.) (box of 150)	75-2010-884

The SmartSource Series Cleaning Kit (supply order number 75-6190-992) shown in Table 3-2 provides a selection of cleaning supplies for the SmartSource in various quantities. All of the items in the cleaning kit can be ordered separately although not in the same quantities shown for this kit.

Table 3-2 SmartSource Series Cleaning Kit

Item	Quantity
Check Scanner Cleaning Card	15
Image Glass Cleaning Pads, pre-saturated with isopropyl alcohol	80
Micro-duster	1
Cotton Wiping Cloths	25

The SmartSource Series Starter Kit (supply order number 75-0820-995) includes cleaning supplies as well as replacement items. Table 3-3 shows the contents of the Starter Kit. (Section 4 of this guide has complete information on all replacement items.) All of the items in this kit can be ordered separately.

Table 3-3 SmartSource Series Starter Kit

Item	Quantity
Track Clearing Spatula	1 package of 5
Image Glass Cleaning Pads, pre-saturated with isopropyl alcohol	1 package of 80
Ink Jet Cartridge and Ink Pad Kit	1 kit, includes 1 cartridge and 1 ink pad
Feeder Roller and Separator Kit	1 kit, includes two feed rollers and one separator assembly
Pocket Fingers	1 package of two fingers

Detailed Cleaning Sequence

Follow these procedures, in the order that they are presented in this section, to clean the unit:

- Turn the unit off
- Remove the top inner and outer covers
- Remove the front image camera removable wall
- Remove the franker roller (if present) and the rear image camera removable wall
- Clean the rear image camera removable wall (and, if necessary, replace the ink pad)
- Remove staples, paper clips, and visible debris from the track
- Blow air along the entire track (paper path) with a micro-duster
- Clean the front and rear image glass and the fixed rear image camera wall
- Clean ink off the endorser cartridge and cartridge housing (as needed to maintain print quality – omit this procedure if print quality is acceptable)

Turn Unit Off

WARNING

Turn the unit off as shown in the following illustrations.

Back of Unit

Expert

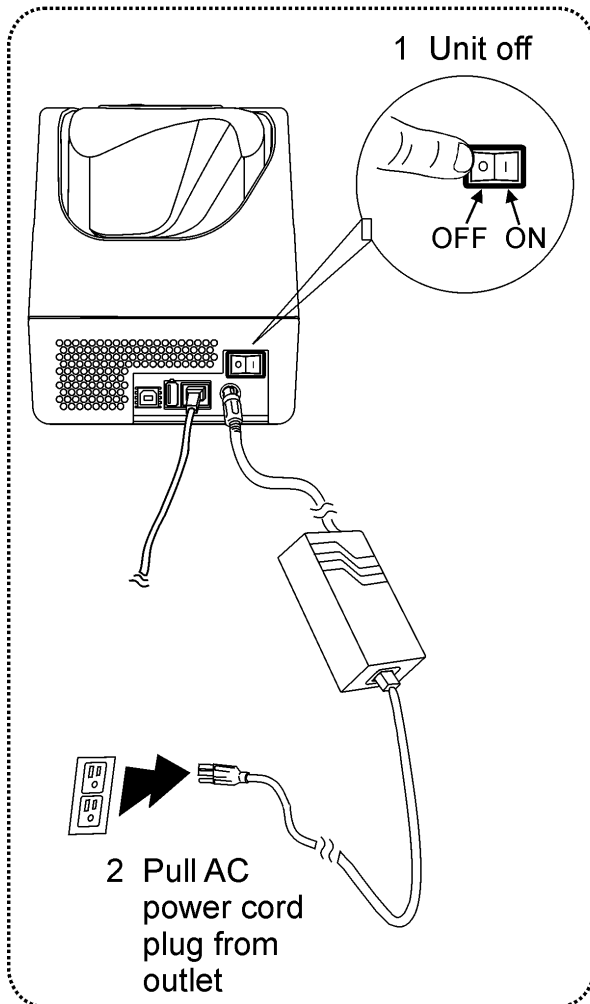

Professional and Value

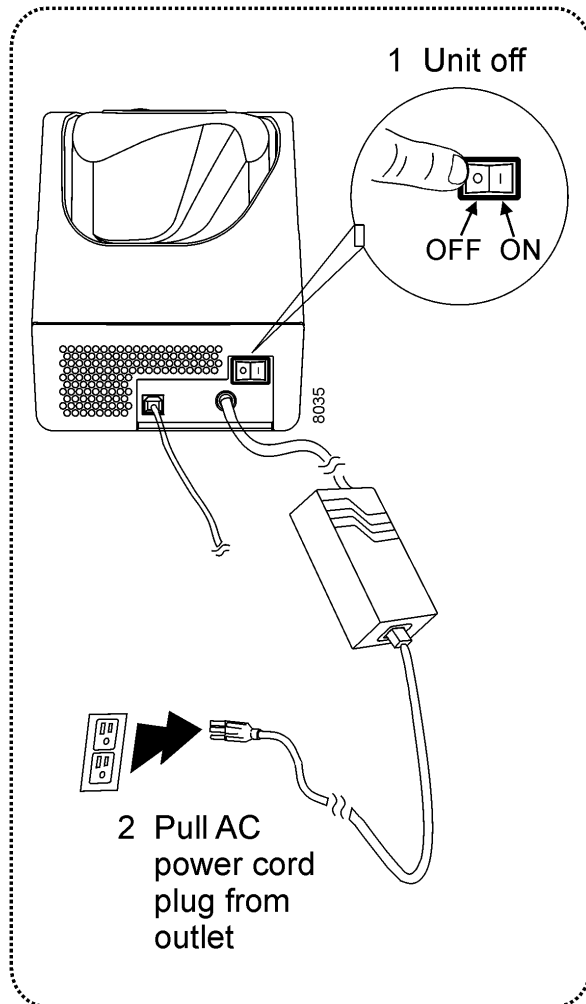

Remove Inner and Outer Covers

1. Remove the top inner and outer covers. Grasp each cover and lift it straight up and off the unit.

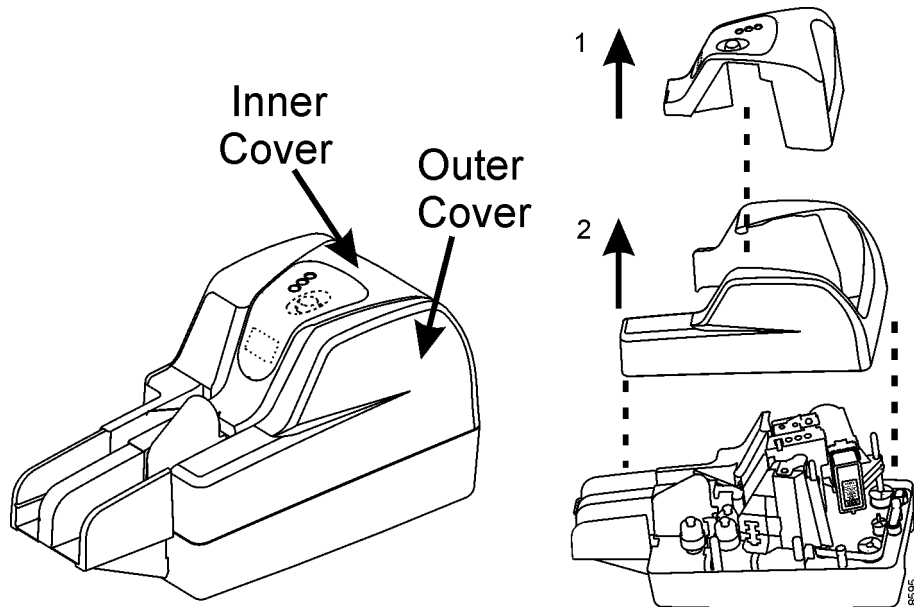

Remove Front Image Camera “Removable Wall”

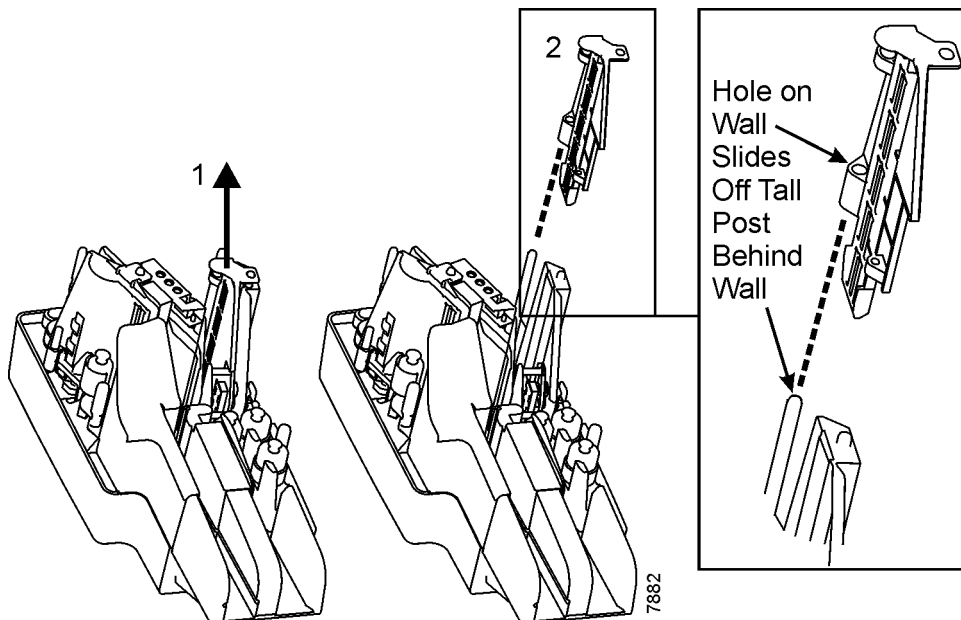

Cleaning the Unit

On SmartSource Professional units that have the ultraviolet option, there are ultraviolet (UV) LEDs underneath the front image camera wall glass.

WARNING
LASER RADIATION
DO NOT VIEW THE IMAGER LIGHT SOURCE DIRECTLY WITH
MAGNIFYING LENSES.
CLASS 1M LASER PRODUCT

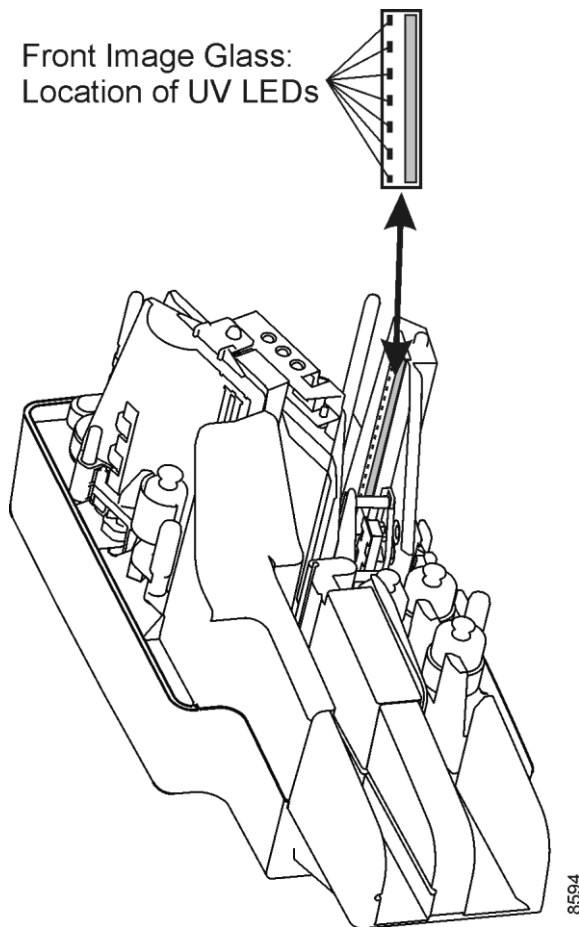

Remove Franker Roller (if Present) and Rear Image Camera “Removable Wall”

Franker Roller

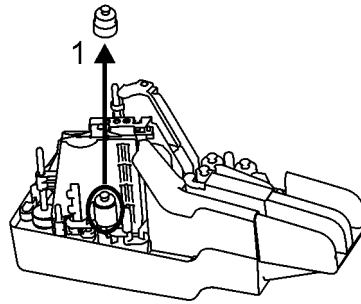

Rear Removable Wall

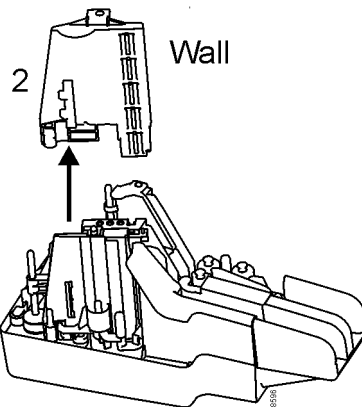
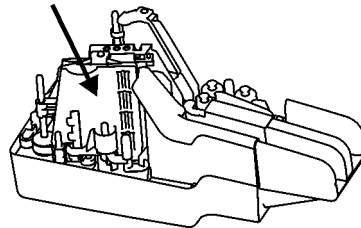

Clean Rear Image Camera “Removable Wall” (and, if Necessary, Replace Ink Pad)

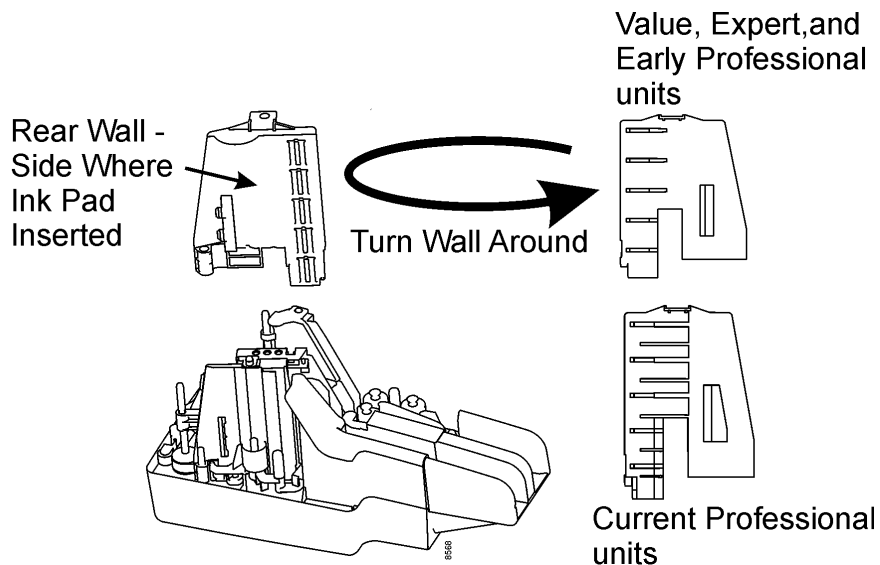

- 1 Wipe off entire wall with Cleaning Pad 75-1804-907 to remove any accumulated debris and/or ink.

Take care that cleaning pad does not pick up ink from ink pad.

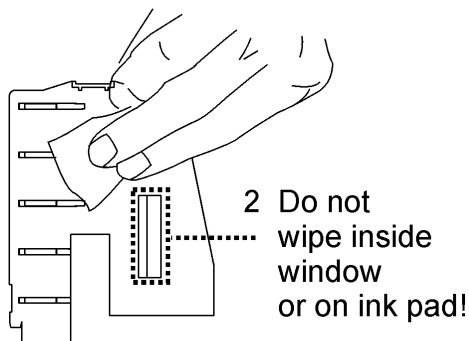

On Value, Expert, and early Professional units, the Ink Jet Cartridge and Ink Pad Kit (75-0860-915) includes one cartridge and one ink pad. **For these units, it is recommended that the ink pad be replaced when the ink cartridge is replaced.**

Current Professional unit rear walls have a built-in extended life ink pad. The rear wall with built-in ink pad is replaced at specified intervals.

- 3 If replacing ink pad, pull old pad out and insert new pad.

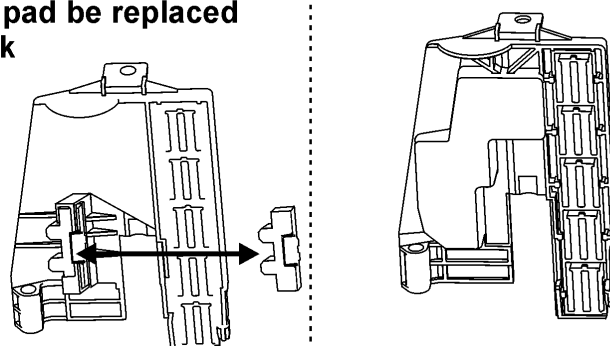

Remove Staples, Paper Clips, and Visible Debris from the Track

Caution

Metal objects such as paper clips and staples that fall underneath the metal base plate may damage the unit. **Before** using the micro-duster to blow air along the paper path, inspect the track for such items as staples and paper clips and remove them from the unit.

Use the track clearing spatula to clear the track.

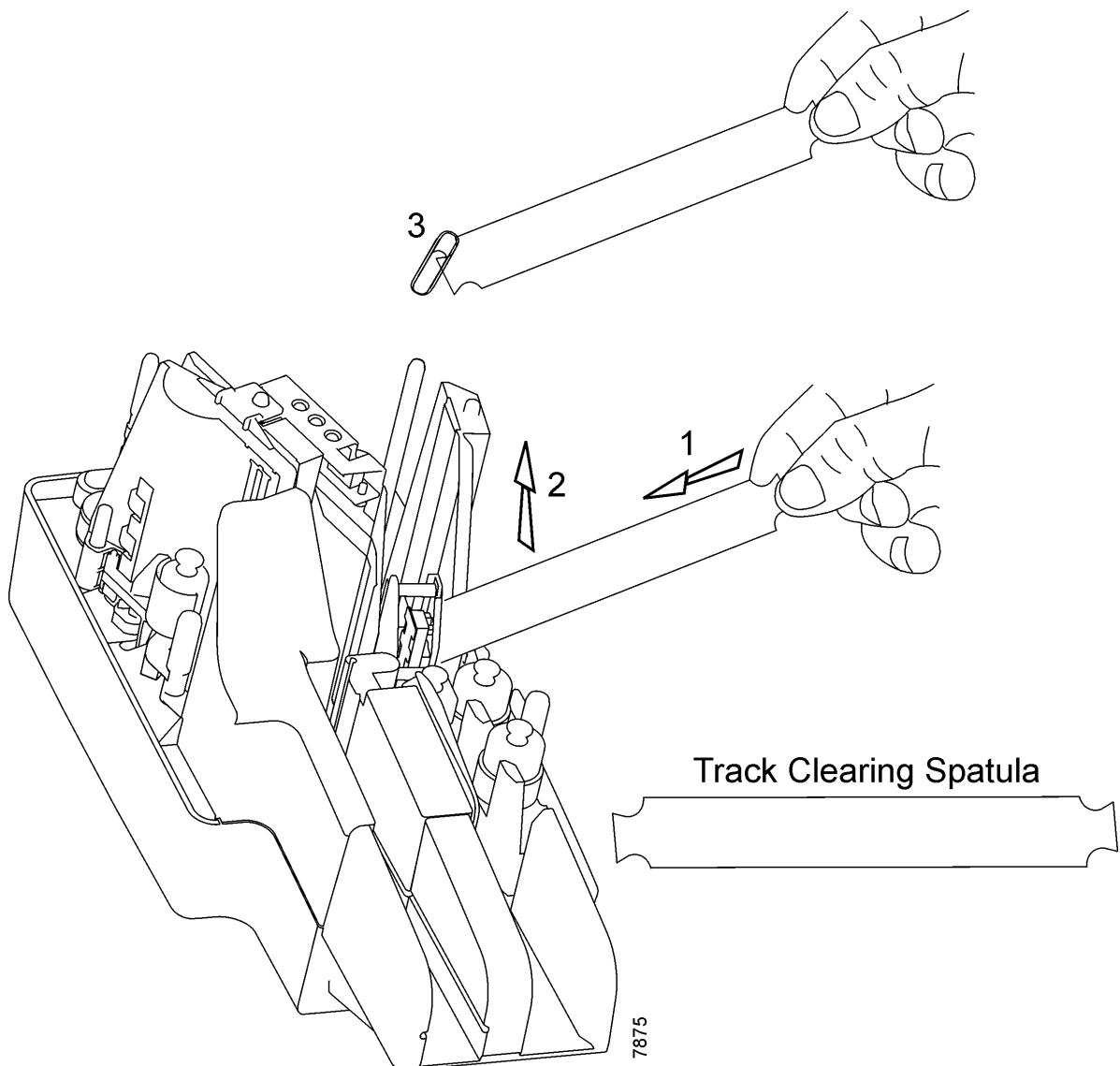

Blow Air Along Entire Track (Paper Path) with Microduster

Arrow ← shows paper path

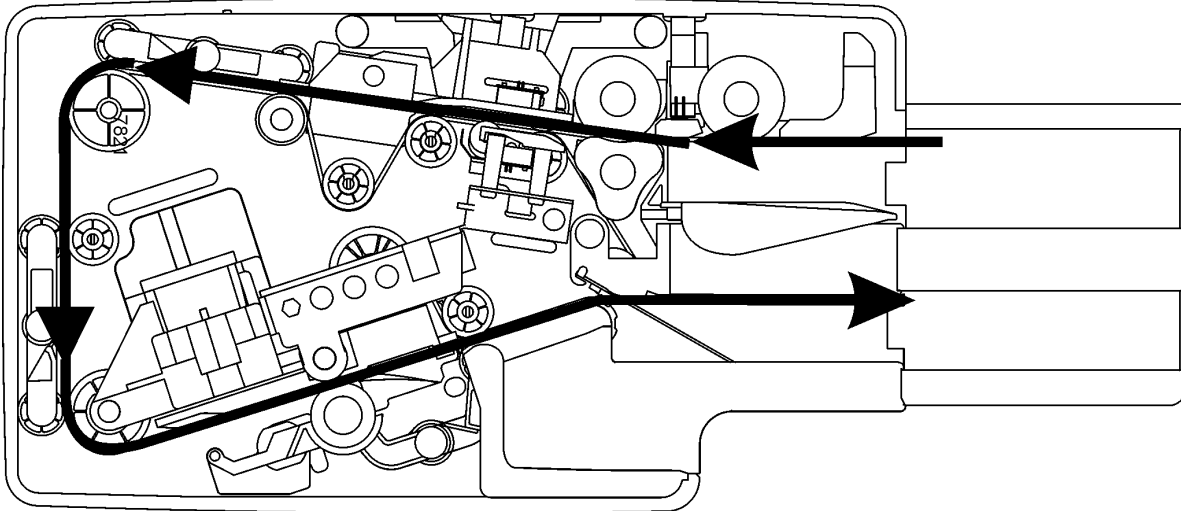

Unit top view with covers off

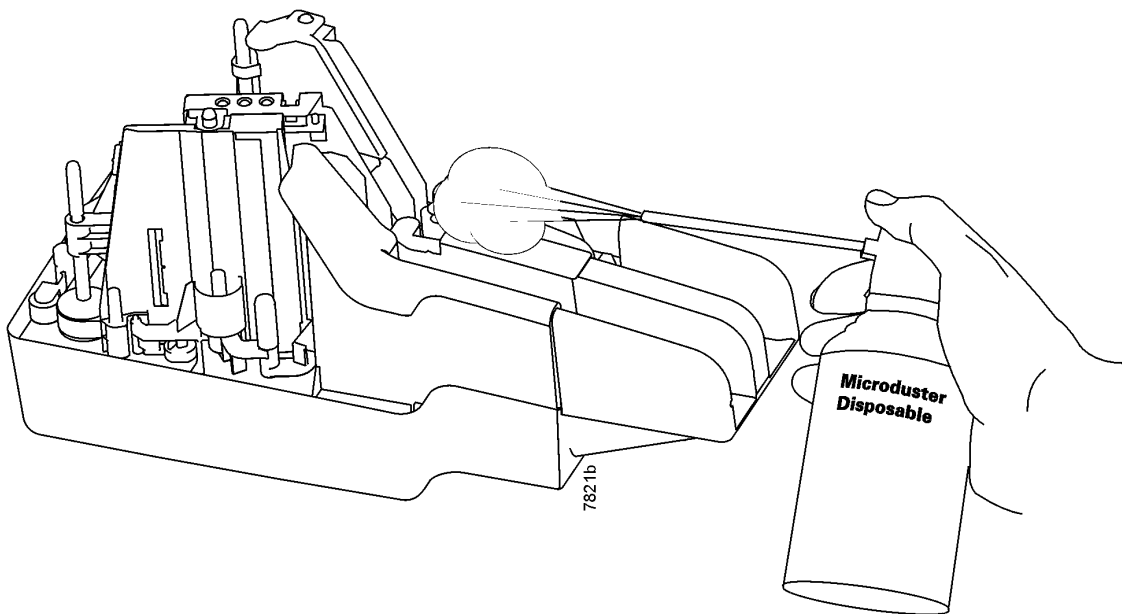

Clean Front and Rear Image Glass and “Fixed” Rear Image Camera Wall

Note: Use a new, unused Cleaning Pad 75-1804-907 for this cleaning procedure.

1. Clean the entire image glass surface by wiping with Cleaning Pad 75-1804-907 whenever document images contain black horizontal streaks.

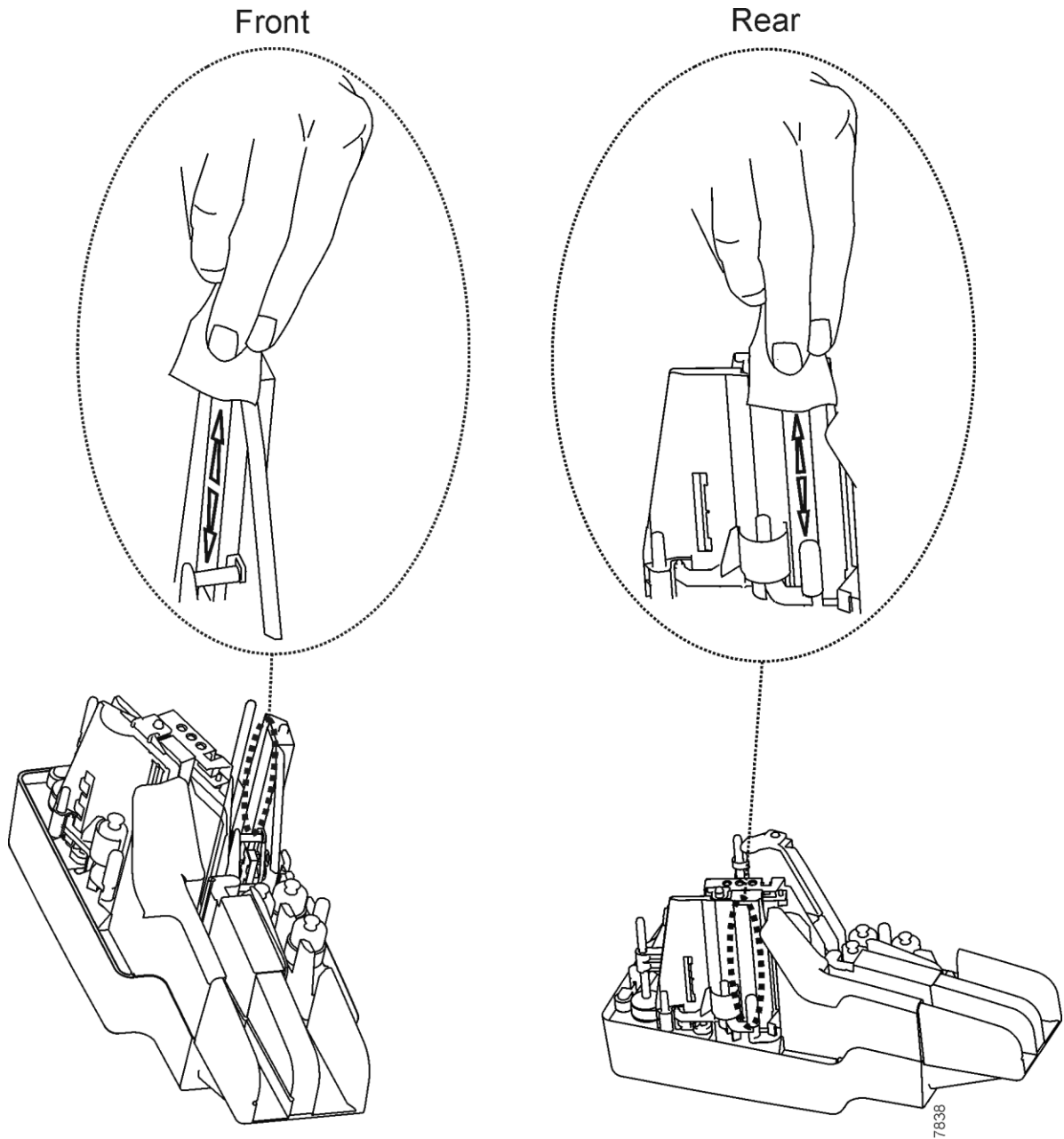

Cleaning the Unit

2. Clean the fixed rear image camera wall by wiping with Cleaning Pad 75-1804-907. Clean the area indicated in the picture below, **but do not wipe with the pad inside the small rectangular cutout in the image wall or wipe the image glass again.**

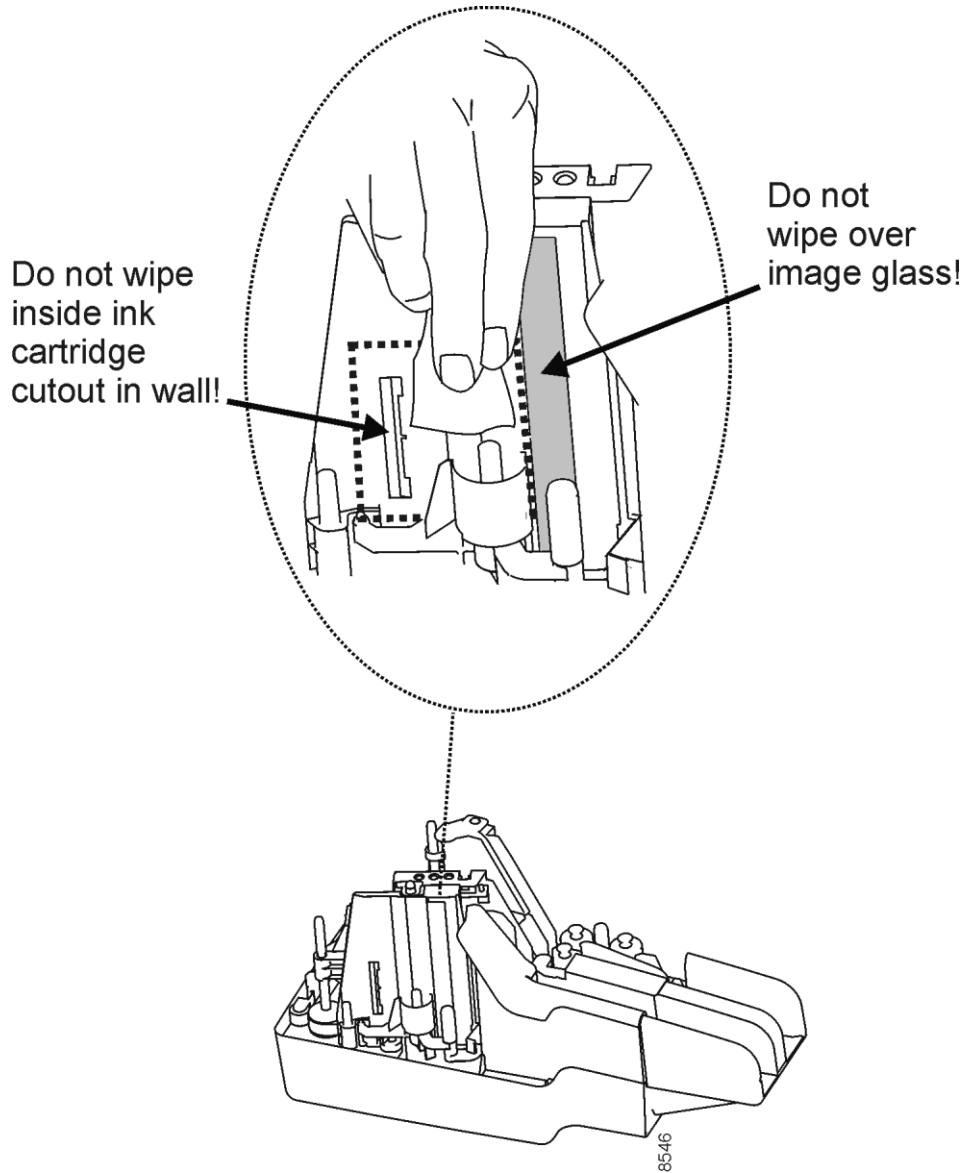

Clean Ink off the Endorser Cartridge and Cartridge Housing

If the unit is producing acceptable print quality for the endorsement, it is recommended that this portion of the cleaning procedure – which cleans the ink cartridge print head – be omitted. However, if the unit exhibits degraded print quality, it is recommended that the following cleaning procedure be performed on the ink cartridge print head and ink cartridge housing.

IMPORTANT

The Digital Check enhanced ink cartridge (Digital Check Store part number 82-2120-984) greatly reduces or eliminates the requirement to clean the cartridge print head in order to maintain print quality. Use of the legacy cartridge (Digital Check Store part number 80-2120-873) may require periodic cleaning of the cartridge print head. When using either ink cartridge, cleaning of the print head should only be performed on an “as needed” basis.

1. Remove the cartridge from the unit. The following illustration shows cartridge removal on Value and early Professional and Expert units.

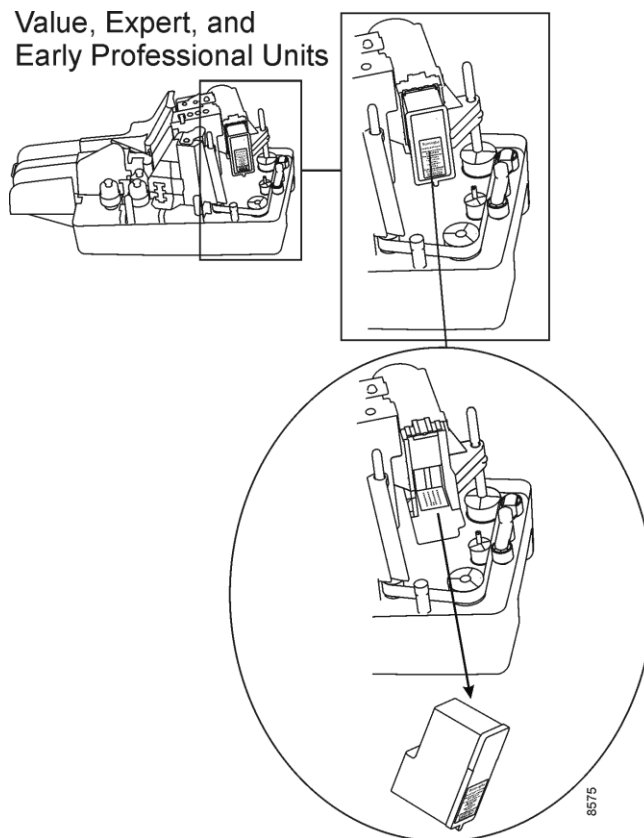

Cleaning the Unit

- a. On Open Professional and Open Expert units, do the following to remove the cartridge.
 - o Press down on the cartridge housing latch to open the cartridge housing.

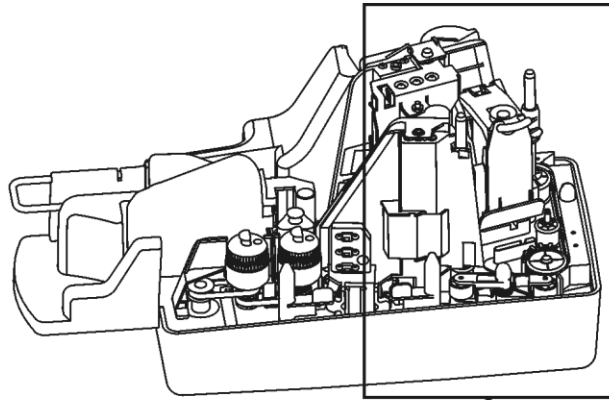

Current
Professional Units

8572

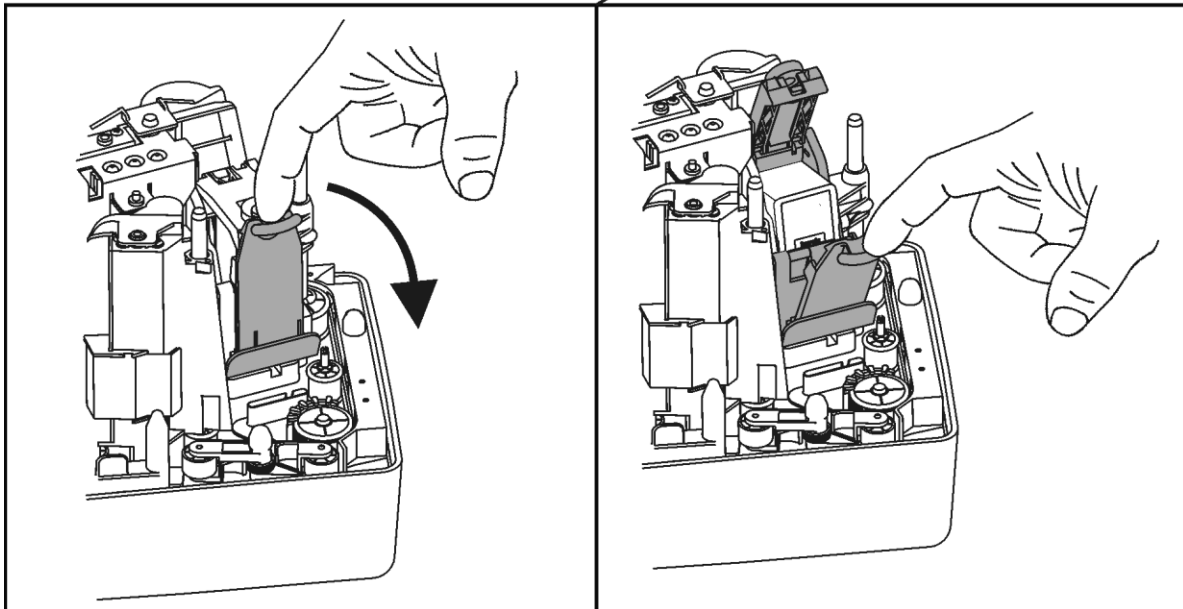

- o Pull the cartridge up and out of the housing.

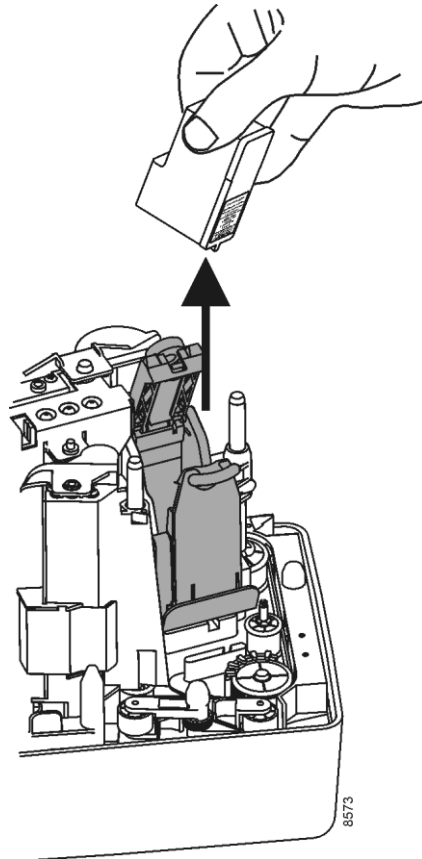

2. Dampen a clean, lint-free cloth with a small amount of water.

Caution

The cloth should not be too wet as water must not drip into or remain on the unit. **When cleaning the print head, do not use alcohol-based or other cleaning solutions.**

Cleaning the Unit

3. Wipe any ink that may be present off the cartridge contacts inside the cartridge housing.

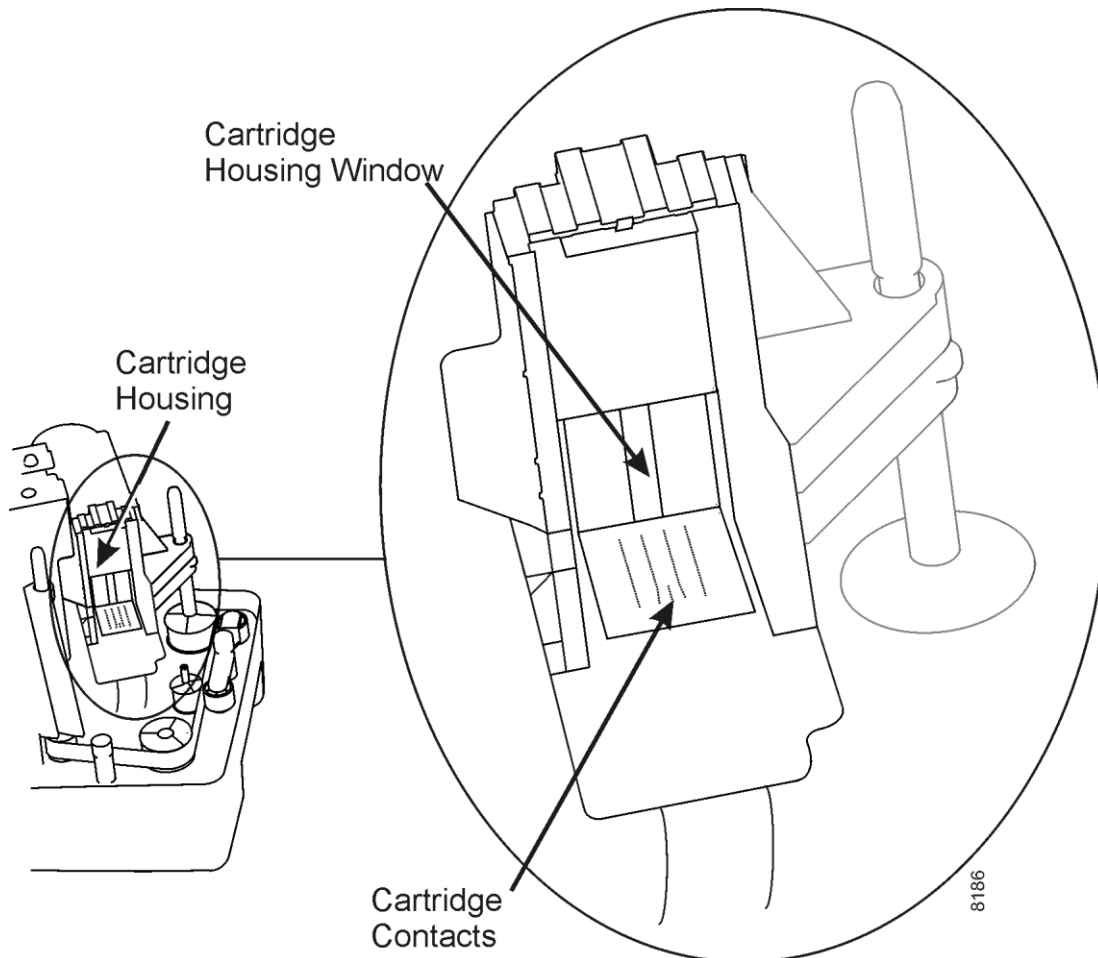

4. Wipe any ink that may be present off the window inside the cartridge housing.
5. **Dampen a clean, lint-free cloth** with a small amount of water.

Note: *The cloth should not be too wet, as water must not drip or remain on the unit.*

Caution

Do not use alcohol to wipe the cartridge nozzles. This will cause damage.

Do not use the Image Glass Cleaning Pads from Digital Check (75-1804-907) to wipe the cartridge nozzles. These pads are pre-saturated with isopropyl alcohol that will cause damage to the cartridge.

6. Hold the cloth gently against the cartridge nozzles for three seconds. Then, wipe the nozzles in one direction only, **UP**, as shown here.

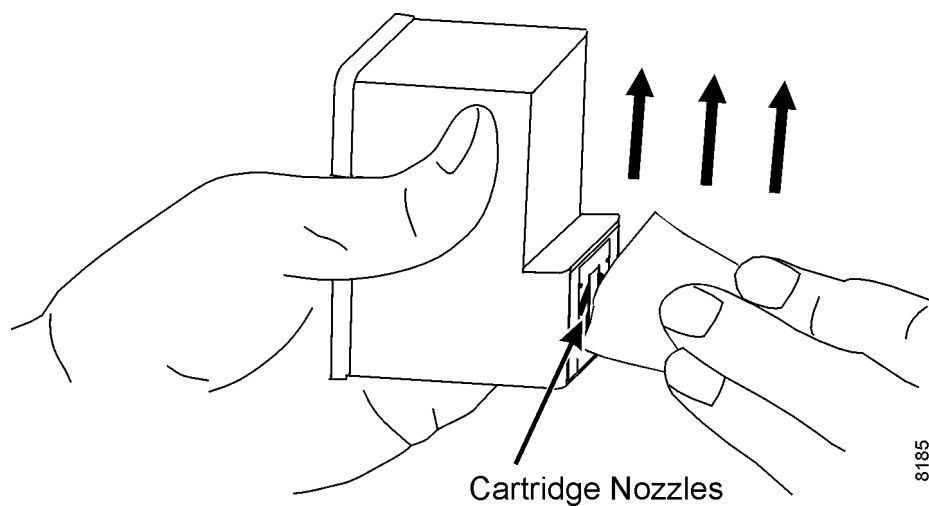

7. Use a clean section of the cloth, or moisten another lint-free cloth with a small amount of water. Hold the cloth gently against the cartridge contacts on the bottom of the cartridge for three seconds. Then, wipe the contacts in one direction only, **sideways**, as shown here.

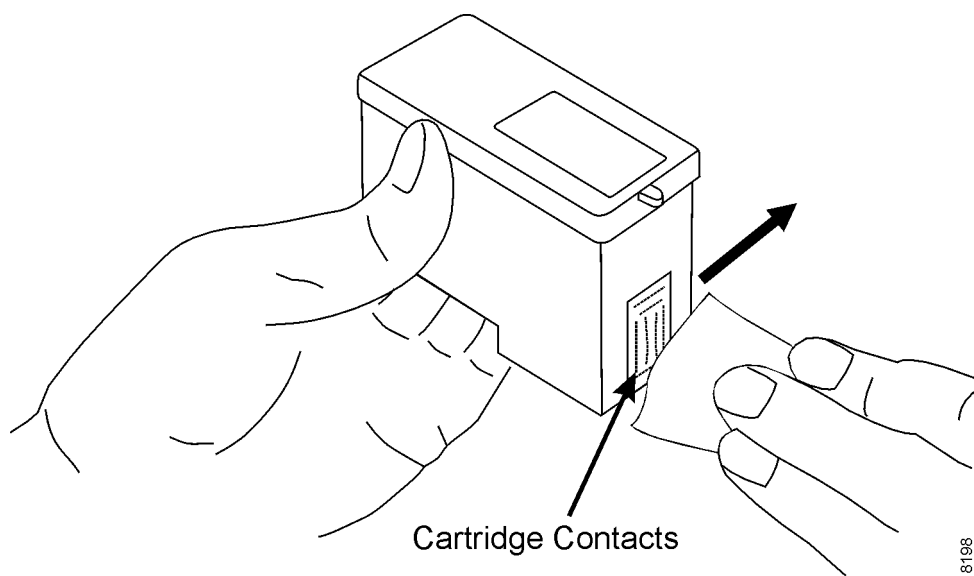

8. With a clean section of the cloth, or another lint-free cloth dampened with a small amount of water, repeat steps 6 and 7.
9. Allow the cartridge nozzles and contacts to dry completely.

Caution

To eliminate any possibility of damage to the cartridge, **it is recommended that the unit be turned off before you insert the cartridge back into the cartridge housing.**

On SmartSource Open series units, place the cartridge back inside the housing assembly and push it down into place.

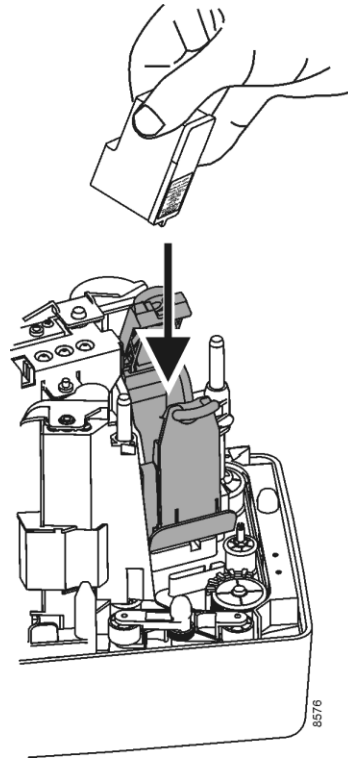

Press the top of the cartridge housing assembly down until it is latched and closed.

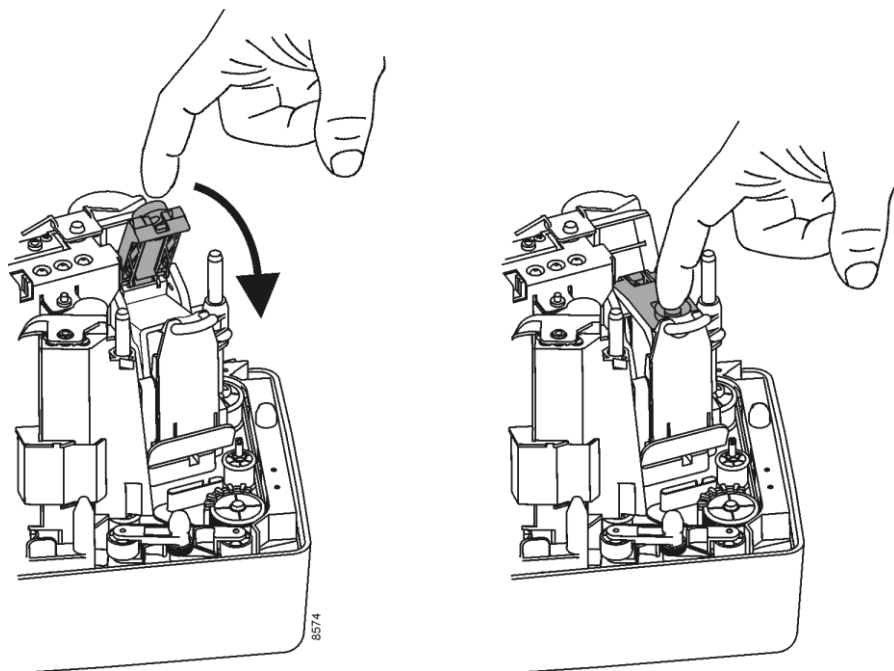

Cleaning the Unit

11. If print quality does not improve, repeat steps 1 through 10 of this procedure one more time.
12. If print quality still does not improve after two cleanings, the cartridge may be empty or defective. Replace the cartridge.

Section 4

Ordering Replacement Items

A number of the components within the SmartSource, such as the rear endorser and front franking stamp, have consumable items associated with their normal operation. Since the SmartSource moves paper documents through the unit track using rollers and belts, over time some components may exhibit wear which may lead to reduced unit performance.

This section provides information on consumables and replacement items available for the SmartSource products. Most replacement items come with installation instructions to guide the operator on the proper replacement procedure, including the following items:

- Ink cartridge and ink pad kit
- Franker roller
- Feeder kit

The Digital Check Store website offers a variety of certified replacement parts to keep the SmartSource unit operating at a high level of performance. Additionally, a limited number of parts are available to address incidents involving accidental damage and/or loss.

- Replacement items can be ordered from Digital Check at 1-847-446-2285, or by visiting www.digitalcheck.com.

Table 4-1 shows the SmartSource replacement items and supply order numbers.

Note: Some machine styles listed in Table 4-1 include one of these style references: –PKT, –PK2, or –A1. To determine the specific unit style, check the serial number/label on the bottom of the unit. The following illustration shows a sample label and the location of the style information on the label. This sample unit style is SSP2-A1.

Machine Style

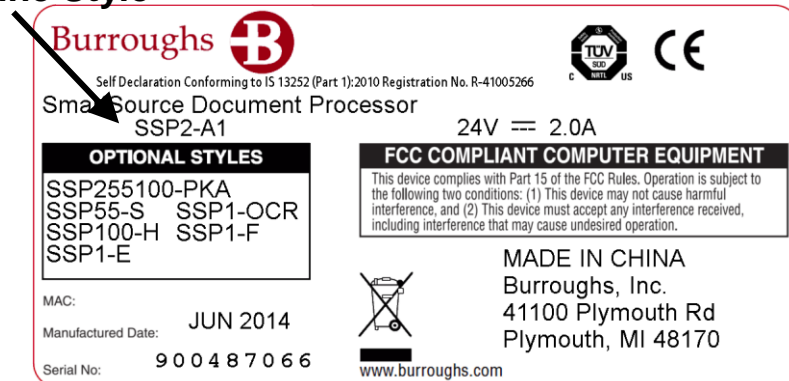

Ordering Replacement Items

Table 4-1 Replacement Items

Description	Machine Style	Supply Order No.
<p>Inkjet Cartridge and Endorser Felt Pad Kit</p> <p>Replace the inkjet print cartridge when it stops printing. See “Inkjet Cartridge Capacity” in Section 1.</p> <p>Replace the endorser ink pad when you replace the ink cartridge or when the ink pad is completely saturated with ink.</p> <p>The capacity of the inkjet cartridge can range from approximately 1,300,000 up to 5,300,000 characters depending on the operational settings and workflow. It is recommended that the cartridge capacity be tested by the user in the actual print environment to define your actual usage.</p>	All	75-0860-915
<p>Endorser Felt Pad Kit (5 in kit)</p> <p>Replace the endorser ink pad when you replace the ink cartridge or when the ink pad is completely saturated with ink.</p> <p>Note: <i>Not used on the SmartSource Open series products.</i></p>	All except, Professional-A1 and Expert-A1 styles	75-0848-918
<p>Franker Roller</p> <p>Includes one inked roller, expected life up to 10,000 documents.</p>	Professional, Expert	75-0575-904
<p>Feeder Rollers and Separator Assembly</p> <p>Includes:</p> <ul style="list-style-type: none"> • Two feeder rollers • One separator assembly – triangle shape <p>Replace worn separator assembly if the unit experiences excessive double-feed of items.</p> <p>Expected life of the feeder rollers and separator assembly is up to one-half million items depending on the quality of the documents.</p>	Professional, Expert	75-0850-920
<p>Feed Tire Kit</p> <p>Includes:</p> <ul style="list-style-type: none"> • Two feeder tires • One separator belt 	Professional, Expert	75-0306-904
<p>Separator Tire Kit</p> <p>Includes: 25 separator belts</p>	Professional, Expert	75-0489-908
<p>Power supply</p>	All	75-0580-904
<p>AC power cord</p> <p>Order by contacting the Digital Check Help Desk at 1-847-446-2285. Specify style number B25-LC. A representative will assist you in determining the correct type of plug for your country.</p>	All	—

Table 4-1 Replacement Items (cont.)

Description	Machine Style	Supply Order No.
USB 2.0 cable, A male to B male, 6'	All	16-1308-994
Top Cover, Outer, Gray	All, except SmartSource Open series	75-0581-902
Top Cover, Outer, Black	Professional –A1	75-0860-935
Top Cover, Inner, Gray	Professional –PKT	75-0582-900
Top Cover, Inner, Gray	Expert –PKT	75-0801-901
Top Cover, Inner, Gray	Value –PKT	75-0805-905
Top Cover, Inner, Gray	Professional –PK2	75-0821-932
Top Cover, Inner, Black	Professional –A1	75-0860-934
Top Cover, Inner, Gray	Expert –PK2	75-0822-933
Top Cover, Inner, Gray	Value –PK2	75-0823-934
Pocket Fingers (package of 2) Expected life of the pocket fingers is 100,000 items, depending on the quality of the documents.	All, except SmartSource Open series	75-0583-908
Long Check Limiters, Wire (2)	All	75-0585-903
Short Document Limiters, Foam (2)	All	75-0604-902
Image Camera Wall, Rear, Removable	All, except SmartSource Open series	75-0587-909
Image Camera Wall, Rear, Removable, Built-In Ink Pad <i>(compatible with Value and early Professional and Expert units that currently have the rear removable image wall 75- 0587-909)</i>	Professional –A1	82241779-000
Image Camera Wall, Front, Removable	All	75-0586-901
Floor Extender with Check Limiter, Single Pocket	All, except SmartSource Open series	75-0584-906
Floor Extender with Check Limiters, Dual Pocket	All, except SmartSource Open series	75-0593-907
Return shipping carton	Professional –A1	75-0860-938
Return shipping carton	All, except Professional –A1	75-0594-905

Ordering Replacement Items

This page intentionally blank

Section 5

Solving Problems

Although infrequent, problems that occur are often due to these conditions in the unit: paper jams or stops, multiple document feeding, and debris. When such a problem occurs, the light pattern on top of the unit is as shown here:

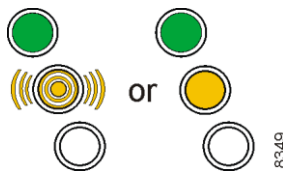

Note: You should consult your application documentation for information on the meaning of the bottom light, the application status light. When lit, this light is always yellow (solid or blinking).

It is important to properly prepare documents for processing (as described in Section 2) to reduce or eliminate exception conditions that may result in decreased unit performance. Check that documents are of acceptable size and condition, and ensure that the following common document defects have been corrected prior to processing:

- Creases, folds, curls, and dog-ear corners
- Rubber bands, paper clips, staples, or foreign objects
- Check stubs and adding machine tapes
- Torn, damaged paper, or a damaged item that has not been placed in a carrier envelope

It is recommended that documents be correctly aligned before being inserted into the unit. See Section 2 for details regarding proper document preparation and loading procedures.

The unit must be maintained as shown in Section 3 to ensure optimum paper handling and operation.

Solving Problems

Possible operational problems that can occur when adequate document preparation is not performed, or when the unit is not properly maintained, are listed below:

- Paper clip/staples/debris in track
- Increased double feeds (worn separator)
- Power supply (including unit not plugged in properly, bad AC power outlet)
- Communications/connections (USB cable or software driver issues)
- Unusual noises (during paper feed or travel through unit)
- Indicators/controls (status lights or Start/Stop button)
- Jams or unexpected document stops (incorrect feeding)
- Feeder (incorrect feeding, double-feeds, skew)
- Reader (MICR/optical reader rejects)
- Image (quality or skew)
- Endorser (print issues – blurry, light, or no print, ink spots, lines, or streaks)
- Pocket (paper buckling or jamming, poor stacking)
- Parts (cracked or broken covers)

Paper Clip/Staples/Debris in Track

- Use the check scanner cleaning card to clean the track.
- Use the track clearing spatula to clear the track.
- If helpful, take out the removable front and rear image camera walls.

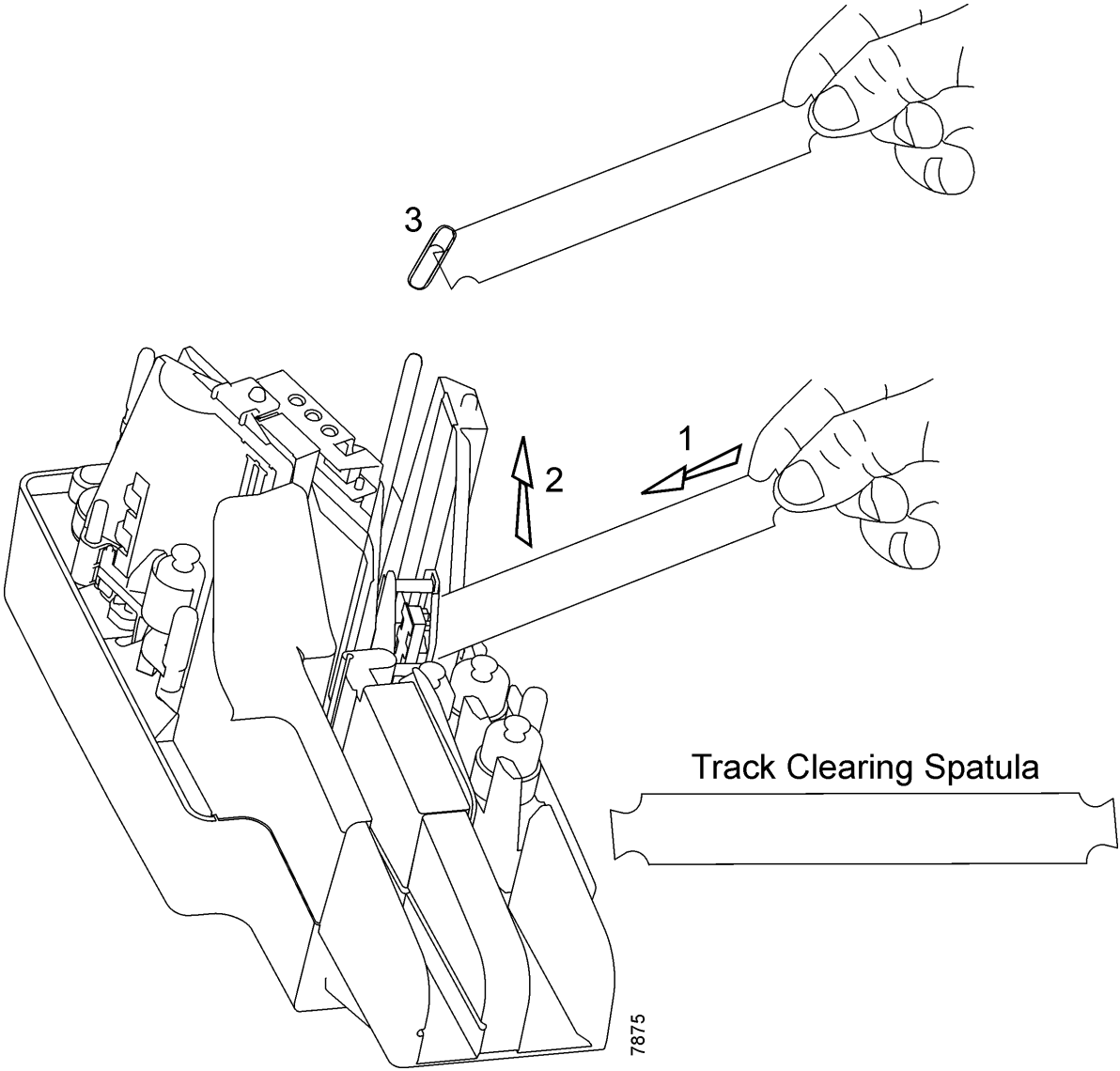

Document Double-Feeds Increase

- Turn the separator (triangle-shape).

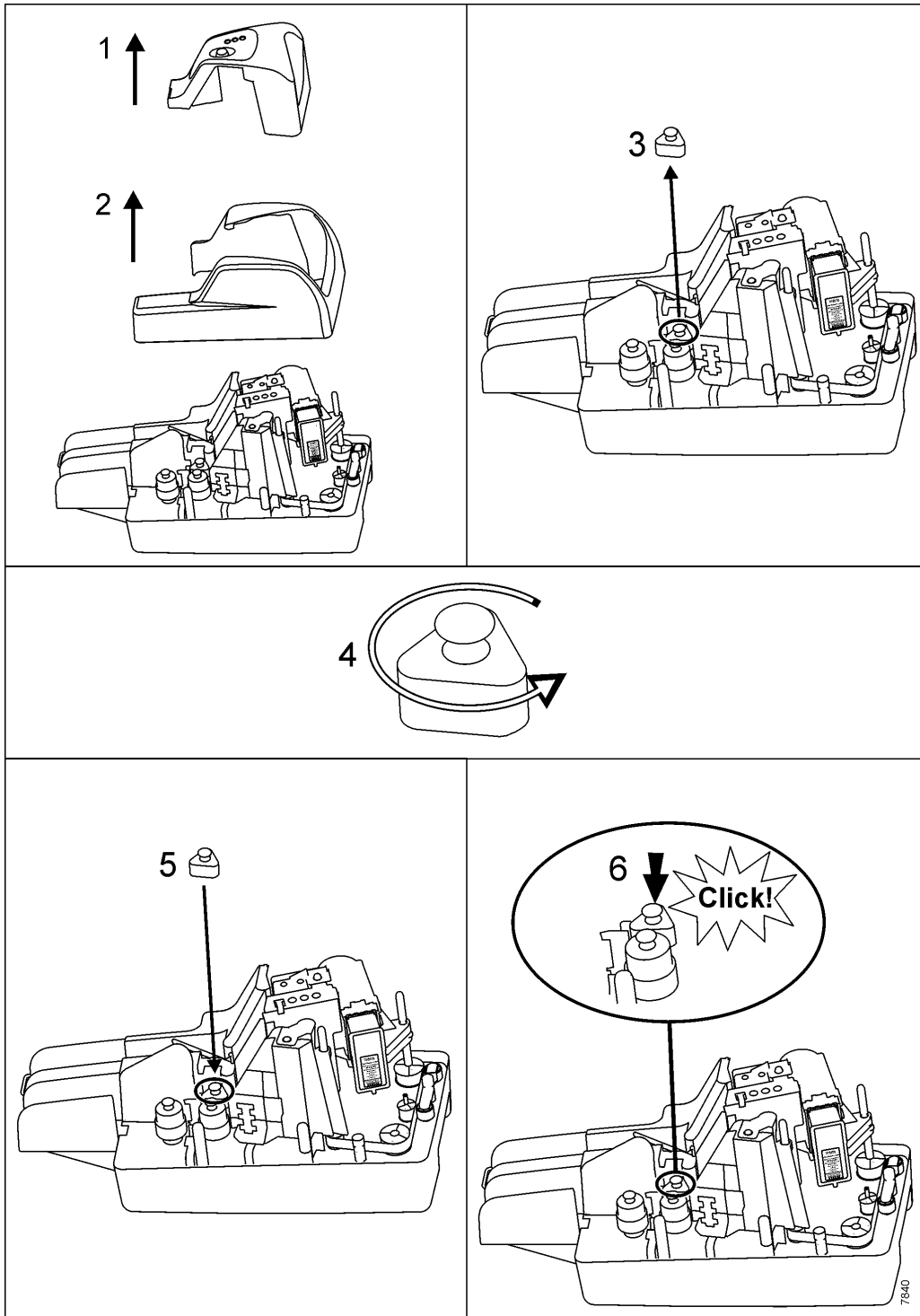

All Problems

Power Supply

Symptom	Possible Cause	Solution
Unit does not power up. No green light on top of unit after pressing On/Off switch.	AC power cord not plugged into an AC power outlet. Note: Green indicator on power supply not illuminated.	Plug AC power cord into a known working AC power outlet.
	Bad AC power outlet. Note: Green indicator on power supply not illuminated.	Verify that the AC power outlet is OK; try a different circuit.
	Power supply cable not fully plugged into back of unit.	Push power supply cable fully into back of unit.
	Defective power supply.	Replace power supply.

Communications/Connections

Symptom	Possible Cause	Solution
Unit does not connect to host PC or a network (Professional, Value, and Expert –UPK units).	Incorrect cable type or defective cable.	Ensure USB 2.0 cable in use and less than 5 meters (~16 ft). Unit shipped with USB 2.0 cable 2 meters (~6 ft) in length.
	Excessive USB cable length.	USB 2.0 cable should not exceed 5 meters (~16 ft) in length.
	Host PC has lost, or could not establish, a USB connection with the SmartSource unit.	Turn off the SmartSource unit and leave the PC powered on. Wait 5 seconds and then turn the SmartSource unit back on. Listen for a “chime” on the host PC, indicating that the host PC has established a new USB connection with the SmartSource.
	Software driver missing, corrupt, or not loaded.	Monitor software driver using Device Manager. Uninstall and/or reinstall driver as needed.

Communications/Connections (continued)

Symptom	Possible Cause	Solution
Unit does not connect to local network (Expert units).	Network connection problem.	Verify that two lights near the Ethernet connector (back of unit) indicate normal network activity. One light on indicates a good connection. The other blinks when data is transmitted or received.
	Unit's Internet Protocol (IP) address does not match network settings.	When the unit powers up, wait until LCD display shows "Expert Series." Press and hold the Start/Stop button for a few seconds. The unit's IP address scrolls across display. Ensure IP address is the required address for network.
	PC firewall is blocking the network connection.	Follow configuration instructions for PC and/or firewall software.
"Lost Connection" - USB disconnection during idle periods.	Outdated software.	Contact application provider to ensure latest version software in use.

Unusual Noises

Symptom	Possible Cause	Solution
Noise while trying to feed paper.	Dirty/worn feeder rollers.	Clean or replace feeder rollers.
Clicking noise as papers travel around the paper path.	Obstruction in paper path.	Inspect paper path, remove debris. Ensure front/rear image camera removable walls and inner and outer top covers are properly positioned/seated.
Fan runs after paper flow stops.	Outdated software.	Contact application provider to ensure latest version software in use.
Noisy fan during paper flow.	Fan obstruction or defective fan.	The unit requires repair.

Indicators/Controls

Symptom	Possible Cause	Solution
No top green light on top of unit.	Multiple causes.	See "Power Supply" conditions.
Papers do not feed when Start/Stop button pressed.	Start/Stop button held down too long.	Press/tap Start/Stop button momentarily to start feeding paper.
Unit makes noises but won't feed paper.	Debris prevents paper from moving through the unit.	See "Feeder."
	Application has not started correctly.	Restart application.

Jams or Unexpected Paper Stops

Symptom	Possible Cause	Solution
Items do not feed correctly.	Multiple causes.	See "Feeder."
Items stop suddenly and have leading edge damage.	Debris/obstruction in paper path.	Examine paper path to locate small bits of paper, tape, staples, etc. Remove debris gently using track clearing spatula 75-0381-907.

Feeder

Symptom	Possible Cause	Solution
Items do not feed correctly.	When the Start/Stop button is pressed, the feeder can be heard trying to feed paper, but the blue-topped feed rollers don't turn.	Swap the two feed rollers. Clean or replace them if problem persists.
	The feeder runs but the unit belt does not move.	Examine paper path to ensure belt has not come off of a roller or is not jammed by debris. Return for service if belt is broken or can not be moved by hand.
	When the Start/Stop button is pressed, there is no sound from the feeder.	If problem exists using other applications the unit requires repair.
More than one document is fed (item double-feeds).	Inadequate paper preparation before feeding items.	Ensure items are properly jogged, aligned, and loaded correctly into the feeder bay.
	Worn separator assembly (triangle-shape).	Rotate or replace separator assembly (triangle-shape).
Items skew as they feed.	Inadequate document preparation before feeding items.	Ensure documents are properly jogged, aligned, and loaded correctly into the feeder bay.
	Worn separator assembly (triangle-shape).	Rotate or replace separator assembly (triangle-shape).
	Incorrect document position/insertion for manual feed.	When manually inserting documents, the entire bottom edge of the document must contact the floor of the track while you push the document forward into the unit.

Feeder (continued)

Symptom	Possible Cause	Solution
Items skew as they feed.	(All units except Professional units with automatic feeder flag.) The floor extender is not installed correctly.	(All units except Professional units with automatic feeder flag.) See Section 1 to correctly install floor extender. Ensure extender tabs are pushed down into slots on unit as far as possible. Extender floor must be even with floor of the feeder bay.
False "Feeder Empty" messages.	Documents are not properly loaded in feeder bay.	Documents should be jogged then loaded into feeder bay with leading edge of paper stack touching end of feeder bay.
	Dirty feeder sensor.	Blow air with Micro-duster through the paper path – where feeder bay touches unit.
	Defective feeder sensor.	Return unit for service.
Double document stop message with single item in track. (False double document.)	Outdated software.	Contact application provider to ensure latest version software in use.
Single items do not feed when inserted (Value units).	Dirty feeder sensor.	Blow air with Micro-duster through the paper path – where feeder bay touches unit.
	Application; application settings.	Ensure that the application is capable of (and settings are correct for) automatic document feed.
Automatic feeder flag does not close. (Professional units with automatic feeder flag.)	Software/hardware synchronization.	Close the application. Turn the unit off and then on. Restart the application.
	Application; application settings.	Ensure that the application is capable of (and settings are correct for) automatic feeder flag.

Feeder (continued)

Symptom	Possible Cause	Solution
Symptom	Possible Cause	Solution
Automatic feeder flag does not close. (Professional units with automatic feeder flag.) (cont.)	Dirty feeder sensor.	Blow air with Micro-duster through the paper path – where feeder bay touches unit.
	Defective feeder sensor.	Return unit for service.
	Broken belt.	Return unit for service.
Automatic feeder flag does not open. (Professional units with automatic feeder flag.)	Software/hardware synchronization.	Close the application. Turn the unit off and then on. Restart the application.
	Application; application settings.	Ensure that the application is capable of (and settings are correct for) automatic feeder flag.
	Dirty feeder sensor.	Blow air with Micro-duster through the paper path – where feeder bay touches unit.
	Defective feeder sensor.	Return unit for service.
	Broken belt.	Return unit for service.

Reader

Symptom	Possible Cause	Solution
The magnetic and/or optical readers have excessive reject rates.	Checks have poor print quality.	Internal items (like cash tickets or batch headers) should be replaced with a fresh supply. If possible, ask document or check provider to correct print quality problems.
	Inadequate document preparation.	Ensure documents are properly jogged, aligned, and loaded correctly in the feeder bay so items are presented properly to the read head.
	Incorrect reader font and/or incorrect reader configuration settings.	Ensure that the software application settings match the actual reader configuration. Ensure that the correct reader font is used.
	Staple/debris near reader.	Inspect reader area for staple on magnet or debris lodged at magnetic head, remove if found. The following picture shows the location of the magnetic head in the unit.

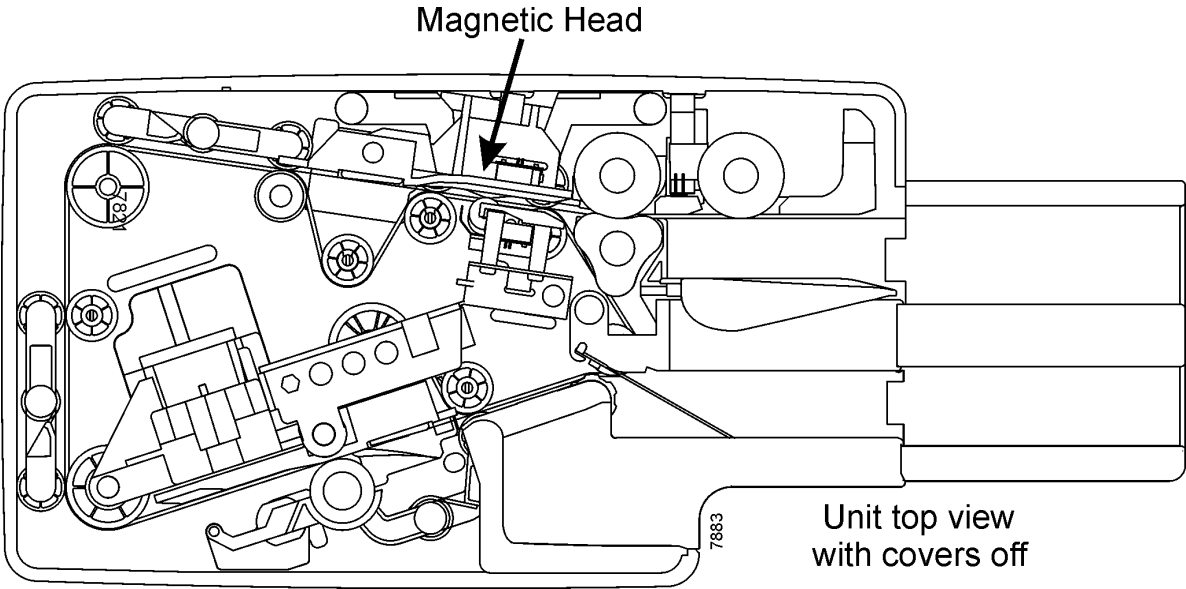

Image

Symptom	Possible Cause	Solution
Images are skewed.	Multiple causes.	See "Feeder" – "Items skew as they feed."
Dark horizontal streaks on all images.	Dirt or ink on image glass.	Perform or repeat the cleaning tasks described in Section 3 – wipe the front and rear image glass clean. Run the check scanner cleaning card through the track. Clean the track walls.
	Ink accumulation around cartridge housing window.	Clean the area around the cartridge housing window. See Section 3 for cleaning procedures.
	(All units except Professional units with automatic feeder flag.) Ink accumulation around window in rear image camera removable wall due to excess ink on ink pad.	(All units except Professional units with automatic feeder flag.) Clean both the fixed and removable rear image camera walls. See Section 3 for cleaning procedures. Replace the ink pad. See Section 4 for information on ordering the ink pad.
	(Professional units with automatic feeder flag.) Ink accumulation around window in rear image camera removable wall due to a fully saturated built-in ink pad in the wall.	(Professional units with automatic feeder flag.) Clean both the fixed and removable rear image camera walls. See Section 3 for cleaning procedures. (Professional units with automatic feeder flag.) Replace the rear removable wall with built-in ink pad. See Section 4 for information on ordering the rear image camera removable wall with built-in ink pad.

Endorser

Symptom	Possible Cause	Solution
Blurry or light print.	Ink accumulation on inkjet cartridge nozzles or contacts.	Clean the inkjet cartridge nozzles and contacts. See Section 3 for cleaning procedures.
	Inkjet cartridge out of ink, or low on ink.	Replace the inkjet cartridge. See Section 4 for information on ordering a new cartridge.
	Print quality level setting is too low.	Use a higher print density setting (which will use more ink) if available.
Light print after inkjet cartridge is cleaned.	Inkjet cartridge out of ink.	Replace the inkjet cartridge. See Section 4 for information on ordering a new cartridge.
	Print quality level setting is too low.	Use a higher print density setting (which will use more ink) if available.
No print.	Inkjet cartridge out of ink.	Replace the inkjet cartridge. See Section 4 for information on ordering a new cartridge.
	Ink accumulation on inkjet cartridge nozzles or contacts.	Clean the inkjet cartridge nozzles and contacts. See Section 3 for cleaning procedures.
	Endorsement not enabled.	Verify that the applications settings are correct for endorsement.
Unusually large ink spots on the back of exception items.	Paper flow started while an exception item was left in the endorser area.	Eject paper stopped in the track during processing.
Excessive ink spots or horizontal lines of ink on the back of processed documents.	Ink accumulation on inkjet cartridge nozzles or contacts.	Clean the inkjet cartridge nozzles and contacts. See Section 3 for cleaning procedures. Replace the inkjet cartridge. See Section 4 for information on ordering a new cartridge.

Endorser (continued)

Symptom	Possible Cause	Solution
Excessive ink spots or horizontal lines of ink on the back of processed documents.	Ink accumulation around cartridge housing window.	Clean the area around the cartridge housing window. See Section 3 for cleaning procedures.
Ink spots or streaks on front of processed document.	(All units except Professional units with automatic feeder flag.) Ink accumulation around window in rear image camera removable wall due to excess ink on ink pad.	(All units except Professional units with automatic feeder flag.) Clean both the fixed and removable rear image camera walls. See Section 3 for cleaning procedures. Replace the ink pad. See Section 4 for information on ordering the ink pad.
	(Professional units with automatic feeder flag.) Ink accumulation around window in rear image camera removable wall due to a fully saturated built-in ink pad in the wall.	(Professional units with automatic feeder flag.) Clean both the fixed and removable rear image camera walls. See Section 3 for cleaning procedures. (Professional units with automatic feeder flag.) Replace the rear removable wall. See Section 4 for information on ordering the rear image camera removable wall with built-in ink pad.
"Cartridge Missing" message displayed on PC.	Inkjet cartridge not properly installed in the cartridge housing.	Turn the unit off. Remove and reinsert the cartridge into the housing. All units except Professional units with automatic feeder flag -- ensure that the edge of the cartridge aligns with the registration sticker on the housing.
	Stray ink contaminated the inkjet cartridge contacts or the contacts in the cartridge housing.	Clean the contacts inside the cartridge housing and on the inkjet cartridge. See Section 3 for cleaning procedures.
	If the cartridge is properly installed in the cartridge housing, and the contacts on the cartridge and in the cartridge housing have been cleaned, the cartridge is defective.	Replace the inkjet cartridge. See Section 4 for information on ordering a new cartridge.

Pockets

Symptom	Possible Cause	Solution
Documents buckle and jam in pockets, stack poorly.	Check limiters not set correctly.	Move the check limiter out far enough to accommodate the longest document.
	(All units except Professional units with automatic feeder flag.) Pocket fingers damaged, missing, or incorrectly installed.	(All units except Professional units with automatic feeder flag.) Ensure pocket fingers are in good condition and correctly positioned in pocket walls.
All documents flow to wrong pocket.	Defective pocketing mechanism.	If problem exists using other applications the unit requires repair.
Some items flow to wrong pocket.	Defective pocketing mechanism.	If problem exists using other applications the unit requires repair.
	Poor magnetic (MICR) reader performance.	Verify reader is performing as expected. See "Reader." If problem exists using other applications the unit requires repair.
	Inadequate image quality.	If a CAR/LAR application is in use verify it is operating correctly, view images if possible. Clean the front and rear image glass and retry.

LCD Display (Expert Units)

Symptom	Possible Cause	Solution
Display is blank or shows incorrect characters.	Application problem.	If problem persists with other applications the unit requires repair.
	Defective display.	The unit requires repair.

Solving Problems

Parts

Symptom	Possible Cause	Solution
Covers/top covers cracked or broken.	Handling or accidental damage.	Contact Digital Check for replacements.