

## Digital Control of DC – DC Buck Converter

Smruthi M Krishnan

Department of Electrical and Electronics  
Engineering  
R V College of Engineering, Bangalore,  
Karnataka, India

Prof. Vasudeva Bannintha K

Associate Professor, Department of Electrical  
and Electronics Engineering  
R V College of Engineering, Bangalore,  
Karnataka, India

### Abstract

The paper describes the design and implementation of a digital controller for DC – DC Buck Converter. Digital controllers are increasingly replacing their analog counterparts due to its improved flexibility, easier integration, programmability, reduced design time, size, cost and improved reliability. Switching devices are selected based on the power handling capability and high frequency switching. Voltage mode control is used in order to get faster response. Proposed DC – DC Buck Converters are controlled using PD controller and Full State Feedback Controller designed using Pole Placement technique. The PD controller has been implemented on an Atmega32 - 8 bit Microcontroller. The Full State Feedback controller has been simulated in MATLAB/SIMULINK.

### 1. Introduction

The field of power electronics is concerned with the processing of electrical power using electronic devices. The key element is the *switching converter*. In general, a switching converter contains a power input, control input and a power output port as shown in fig 1. The raw input power is processed as specified by the control input, yielding the conditioned output power. In a *dc-dc converter*, the dc input voltage is converted to a dc output voltage having a larger or smaller magnitude.

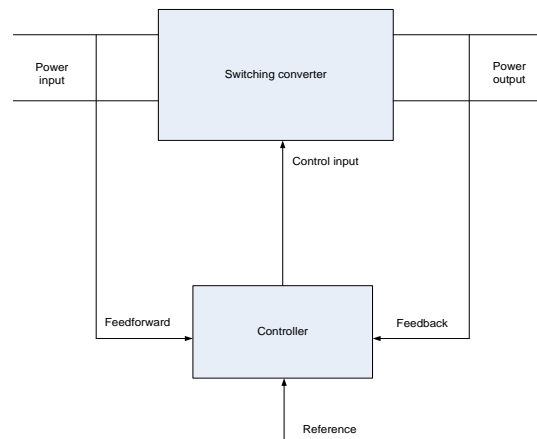

Figure 1. A General Switching Converter with Controller

A Digital controller implementation has the following advantages: improved flexibility, reduced design time, programmability, elimination of discrete tuning components, improved system reliability, easier system integration, and possibility to include various performance enhancements.

### 2. Converter Topology and Operation

The converter topology selected is buck converter. The input voltage is 12V and output voltage has to be regulated to 5V. The load current is 1-2A range. The switching frequency of  $f_s = 62\text{kHz}$  is selected. It is desired to maintain a tight voltage regulation.

In buck converter the average output voltage is lesser than the dc input voltage[2][3][4]. The output voltage is controlled by controlling the switching duty cycle. The switching buck converter is also called as step down converter is shown in fig 2.

The ratio of output to input is given by

$$\frac{v_0}{v_i} = D = \frac{I_{in}}{I_0}$$

The term D is the duty ratio and defined as the ratio of the ON time of the switch to the total switching period.

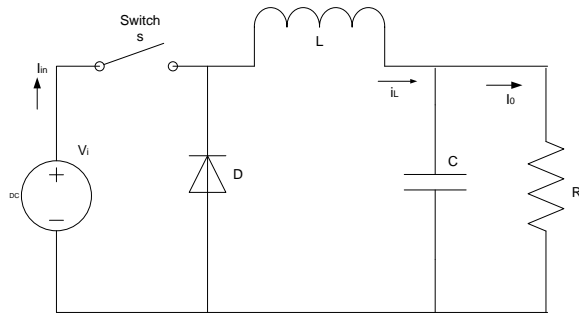

Figure 2. Buck Converter Circuit

Using Kirchoff's voltage and Kirchoff's current laws, the dynamics is described by the following set of equations

When switch  $u=1$

$$L \frac{di}{dt} = -v_o + v_i$$

$$C \frac{dv}{dt} = i - \frac{v_o}{R}$$

When switch  $u=0$

$$L \frac{di}{dt} = -v_o$$

$$C \frac{dv}{dt} = i - \frac{v_o}{R}$$

By comparing the above equations we get

$$L \frac{di}{dt} = -v_o + uv_i$$

$$C \frac{dv}{dt} = i - \frac{v_o}{R}$$

### 2.1. Design Specification

Input voltage  $v_s = 12V$

Output voltage  $v_o = 5V$

Load current  $I_o = 2A$

Switching frequency  $f_s = 62KHz$

Time period  $T_s = 0.016 \text{ ms}$

### 2.2 Duty cycle

For calculation of the duty ratio we will first of all assume that the converter is in steady state. The switches are treated as being ideal, and the losses in the inductive and the capacitive elements are neglected. Also it is important to point out that the following

analysis does not include any parasitic resistances (all ideal case).

$$\text{Duty Ratio } D = \frac{v_o}{v_i} = 0.416$$

### 2.3 Inductor

From Fig 2 we can derive a simplified differential equation based on the assumption that the voltage across the load, and thereby across the capacitor, is fairly constant. The differential equation in terms of the current through the inductor, when the switch is closed, may now be written as

$$L = \frac{v_i - v_o}{f_s I_{ripple}}$$

The current ripple will be limited to 30% of maximum load.

$$I_{ripple} = 0.3I_o = 0.6A$$

$$L = 78\mu H$$

### 2.4. Transformer core selection

The size of a power transformer is determined by Area product, and is given by the product of the core cross section ( $A_c$ ) and the window area ( $A_w$ )

Area product ( $A_p$ ) = Cross section area ( $A_c$ ) x Window area ( $A_w$ )

An appropriate core will be selected which must have area product greater than the calculated  $A_p$  [4]. Area product is calculated before selecting the suitable core by using below formula.

$$A_p = \frac{(\sqrt{D} * P_{out} * (1 + \frac{1}{\eta}))}{(k_w * f_s * B * J * 10^{-6})}$$

$$= 382.70\text{mm}^4$$

Where,

$$k_w = 0.5 \quad B = 0.3T \quad J = 6A/\text{mm}^2$$

$K_w$ =Window Utilization Factor;  $J$ =Current Density;

$B$ =Flux Density;  $P_{out}$ =Output Power;

$f_s$ =Switching Frequency;  $D$ =Maximum Duty Cycle

$\eta$ =Efficiency

#### 2.4.1. Core selection

Core part number : T106-26

Material : Iron Powder

Inductor factor  $A_L$  :  $93\text{nH/T}^2$

#### 2.4.2. Number of turns

Inductance L is given by  $L = A_L * N^2$

$A_L$  : inductor factor

$N = 30$  Turns

#### 2.4.3. Selection of wire gauge

Wire gauge is selected based on the RMS current in each winding. RMS current for each winding can be calculated as

$$I_{rms} = I_0 \sqrt{D} = 2 \times \sqrt{0.416} = 1.29\text{A}$$

$$\text{Area of conductor} = \frac{I_{rms}}{J} = 0.215\text{mm}^2$$

The AC resistance increased due to Skin depth and calculated as follows

$$s = \sqrt{\frac{2}{\text{conductivity} * 2 * \pi * f_s * \mu}}$$

$$\text{Permeability}(\mu) = 1.4 * \pi * 10^{-7} \text{ turns/A}^2$$

Therefore selected wire should have a diameter less than 0.897mm(or  $2 * s$ ).

### 2.5 Capacitor

The output capacitor is assumed to be so large as to yield  $v_o(t) = V$ . However, the ripple in the output voltage with a practical value of capacitance can be calculated. Assuming that all of the ripple component in  $i_L$  flows through the capacitor and its average component flows through the load resistor. Effective series resistance (ESR) is used to dominate the voltage ripple and when ESR requirement is met, the capacitors capacitance is usually adequate. The ripple voltage is limited to 10% of maximum load.

$$dv = 0.1 \times v_o = 0.5V$$

$$C = \frac{I_{ripple} * \frac{1}{f_s}}{dv - (I_{ripple} * esr)} = 20\mu F$$

## 3. Controller Design

The output voltage of the switch-mode DC-DC converters are regulated to be within a specified range in response to changes in the input voltage and the load current. There are two control methods for DC-DC converters: voltage mode control and current mode control. There are three main problems that can be examined in the study of systems in the controls: system dynamics, system identification or modelling, and system control. In system control, the system is known, and the input to the system that produces a desired output must be determined.

In the last section we saw that the steady-state output of a dc-dc converter, usually the output voltage, is controlled by the duty ratio. To account for changes in load current, input voltage, losses, and non idealities in the converter, feedback based control is required. The sensed output voltage is multiplied by a feedback gain before being compared with a reference value. The error is fed to an appropriate error compensator that generates a control voltage, which is converted to duty ratio  $d$  by the PWM block[1][6].

The proposed digital controller is shown in fig 3. The output voltage is sensed and compared with a reference voltage. The error signal is given as the input to the PD regulator. The output of PD regulator is given as the input to the pulse width modulator. The duty cycle is adjusted based on the error signal to make the output voltage follow the reference value.

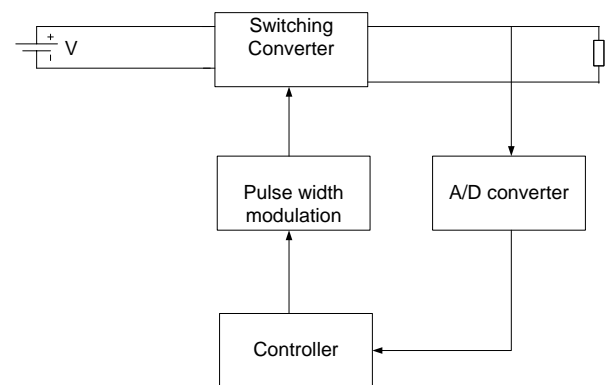

Figure 3. Block Diagram of Digital Controller

A controller has to be designed to regulate the output voltage of a buck converter to a constant value. The specifications and parameters are input voltage is 12v and output voltage is regulated to 5v. The load current is 1-2A range. The switching frequency of  $f_s = 62$  KHz is selected

The transfer function of system is given by

$$\frac{v_o}{v_i} = \frac{r_c C s + 1}{L C s^2 + (r_c + r_l) C s + 1}$$

**3.1. PD Controller**

A digital PID controller and its variants can be designed using a variety of methods available in literature [4,5,6]. A PD controller is a simple two term controller. The transfer function of the most basic form of PD controller is given by

$$c(s) = k_p + k_d s$$

Where  $k_p$  – proportional gain  
 $k_d$  – derivative gain

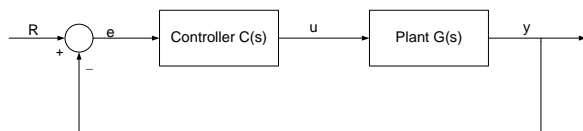

Figure 4. PD Controller Block Diagram

Figure 4 shows the PD controller in a closed loop unity feedback system. The variable  $e$  denotes the tracking error, which is sent to the PD controller. The control signal  $u$  from the controller to the plant is equal to the proportional gain ( $k_p$ ) times the magnitude of the error plus the derivative gain ( $k_d$ ) times the derivative of the error. Four major characteristics of the closed-loop step response are rise time, overshoot, steady state error, settling time. The controller gains were determined experimentally. The following figure shows the simulation result of PD controller applied to Buck Converter

**3.2. Controller Design using Pole Placement Technique**

For a system that is completely controllable and where all the states are accessible, feedback of all of the states through a gain matrix can be used to place the poles at any desired location in the complex plane [5]. The control law used for state feedback is

$$u = -kx$$

which uses the matrix  $K$  to place the poles of the system at desired locations. This type of compensator is said to employ full state feedback (FSFB). A FSFB regulator is shown in fig 5

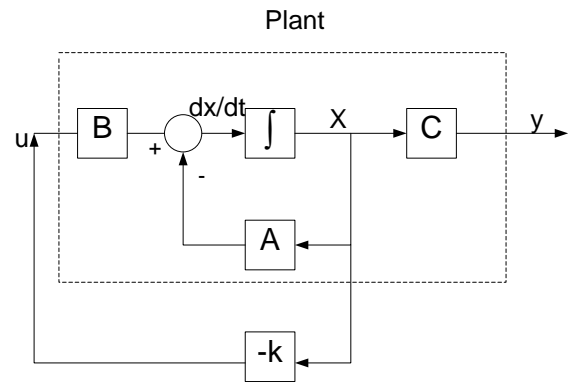

Figure 5. Full State Feedback Regulator

Ackermann’s formula may be used with single-input, single-output (SISO) systems. Ackermann’s formula is

$$K = [0 \ 0 \dots \dots \ 1] M_c^{-1} (A^n + \alpha_1 A^{n-1} + \dots + \alpha_{n-1} A + \alpha_n I)$$

**3.2.1 State Space Model**

Modeling using state space averaging is well known method since many years. The state space averaged model of the converter can be expressed as

$$\dot{x} = Ax + Bu$$

$$y = cx$$

The state variables are the output voltage and inductor current

$$x = \begin{bmatrix} i_o \\ v_o \end{bmatrix} \quad y = v$$

The matrices of the system are written as follows

$$A = \begin{pmatrix} 0 & -\frac{1}{L} \\ \frac{1}{C} & -\frac{1}{RC} \end{pmatrix} \quad B = \begin{bmatrix} \frac{v_d}{L} \\ 0 \end{bmatrix} \quad C = \begin{bmatrix} 1 \end{bmatrix}$$

The main advantage of state space controllers is pole placement. This method allows placing poles of the system to obtain desired outputs. The above system is completely controllable and observable. In this case we choose the damping factor  $\xi$  and time of regulation  $t_r$ .

$$t_r = \frac{3}{\xi \omega_n}$$

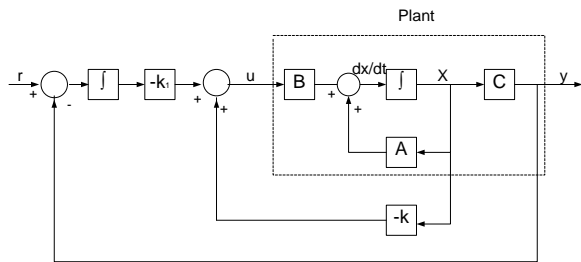

Figure 6. Full State Feedback Controller

Let,  $r$  = system input when state variable feedback is employed

$\sigma$  = feedback signal obtained from state variables

$u$  = plant input

The feedback signal is obtained from state feedback and it is related to the state variables by the equation

$$\sigma = kx$$

Therefore plant input is given by the control law

$$u = r - kx$$

By comparing between the characteristic polynomial of system with the desired polynomial gives the design equations of the feedback coefficients.

#### 4. Simulation Results

The controller was simulated in MATLAB/SIMULINK to verify the properties of proposed controller. The parameters of converter used in simulations are  $L=80 \mu H$ ,  $C=22 \mu F$ ,  $R=100$ . Damping factor and time of regulation for voltage loop  $\xi=0.016$ ,  $t_r=0.004s$ .

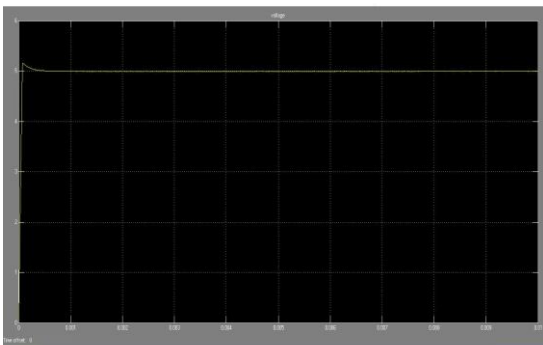

Figure 7. Simulation of PD Controlled Buck Converter

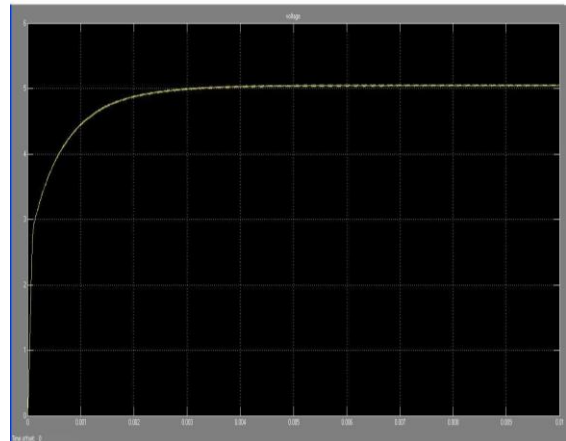

Figure 8. Simulation of Full State Feedback Controller using Pole Placement Technique

#### 5. Hardware Setup

Digital control of buck converter is done using ATmega32 controller.

- Switch : Power MOSFET IRF540N 100v 33A. With these ratings, the same power MOSFET was being used in the main switch
- Inductor: The inductance value chosen was 80uH.
- Capacitor: The value selected was 22uF

The inductor and capacitor values were calculated using the following

$$\text{Duty cycle : } d = v_o/v_{in}$$

$$\text{Maximum ripple current: } di = 0.3 \cdot I_o$$

$$\text{Inductor value : } L = ((v_{in}-v_o) \cdot (d/f_s))/di$$

$$\text{Maximum ripple voltage : } dv = (0.1 \cdot v_o)$$

$$\text{Capacitor value : } C = (di \cdot (1/f_s))/(dv \cdot (di \cdot esr))$$

Hardware implementation of buck converter is shown in Fig 9 and PWM input to the MOSFET and regulated output voltage is shown in Fig 10.

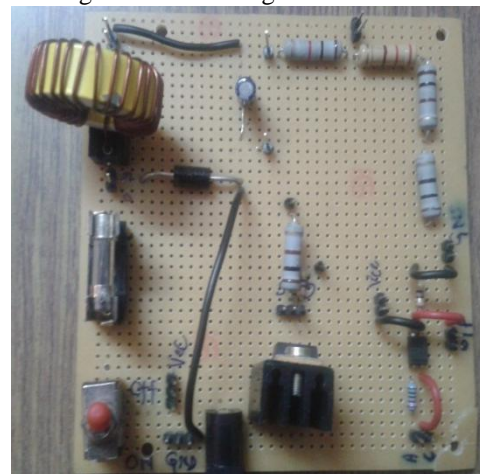

Figure 9. Buck Converter Circuit



Figure 10. PWM Input to the Mosfet (Green) and Regulated Output Voltage (Yellow)

New Age International (P) Limited, 2009, first edition, ISBN 10: 8122403395 / ISBN 13: 9788122403398.

[6] Hebertt Sira-Ramírez, Ramón Silva-Ortigoza, “control design techniques in power electronic devices”, Springer-Verlag London Limited 2006, ISBN-13: 978-1-84628-458-8

[7] B. Arbetter and D. Maksimovic, “Control Method for Low- Voltage DC Power Supply in Battery – Powered Systems With Power Management,” IEEE Power Electronics Specialists Conference, St. Louis, Missouri, 1997.

## 6. Conclusion

Digital controller implementation allows potentially much greater flexibility and better utilization of switching power converters. In this paper, design and implementation of a digital controller for an experimental low-power Buck Converter has been explained. A buck converter circuit was realized with appropriate Inductors and Capacitors. Control of buck converter is done using PD controller and Pole Placement technique. The proposed controller structure is simulated in MATLAB/SIMULINK and is also implemented using Atmega controller.

## 7. References

- [1] Yousefzadeh, “Proximate Time-Optimal Digital Control for DC-DC Converters” Power Electronics Specialists Conference, 2007. PESC 2007. IEEE
- [2] L Wuidart, “Topologies for Switched Mode Power Supply” Application Note, STMicroelectronics, 1999.
- [3] Abraham I Pressman, Keith Billings, Taylor Morey “Switching Power Supply Design”, McGraw-Hill Prof Med/Tech, 26-Mar-2009, 3rd edition, ISBN 13: 9780071482721 ISBN 10: 0071482725.
- [4] Ned Mohan, Tore M Undeland and William P Robbins, “Power electronics, Converters, applications and design” 3<sup>rd</sup> edition, 2006 by John Wiley & sons.
- [5] L Umanand, S R Bhatt, “Design of Magnetic Components for Switched Mode Power Converters”,