

# 3M Ergonomic Products



Solutions for **Comfort**  
and **Productivity**



**3M** *Innovation*

# 3M™ Ergonomics

Endorsed by



Meet AOA specifications for VDT glare reduction

## Innovation Technology

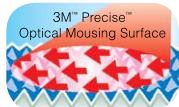

3M™ Precise™ Optical Mousing Surface is designed to enhance light reflectivity and contrast to improve the tracking of optical mouse



3M Workspace Solutions has a wide range of products that enhance your comfort and productivity while you work. Discover new levels of office comfort with our quality products that offer you a better way to work.

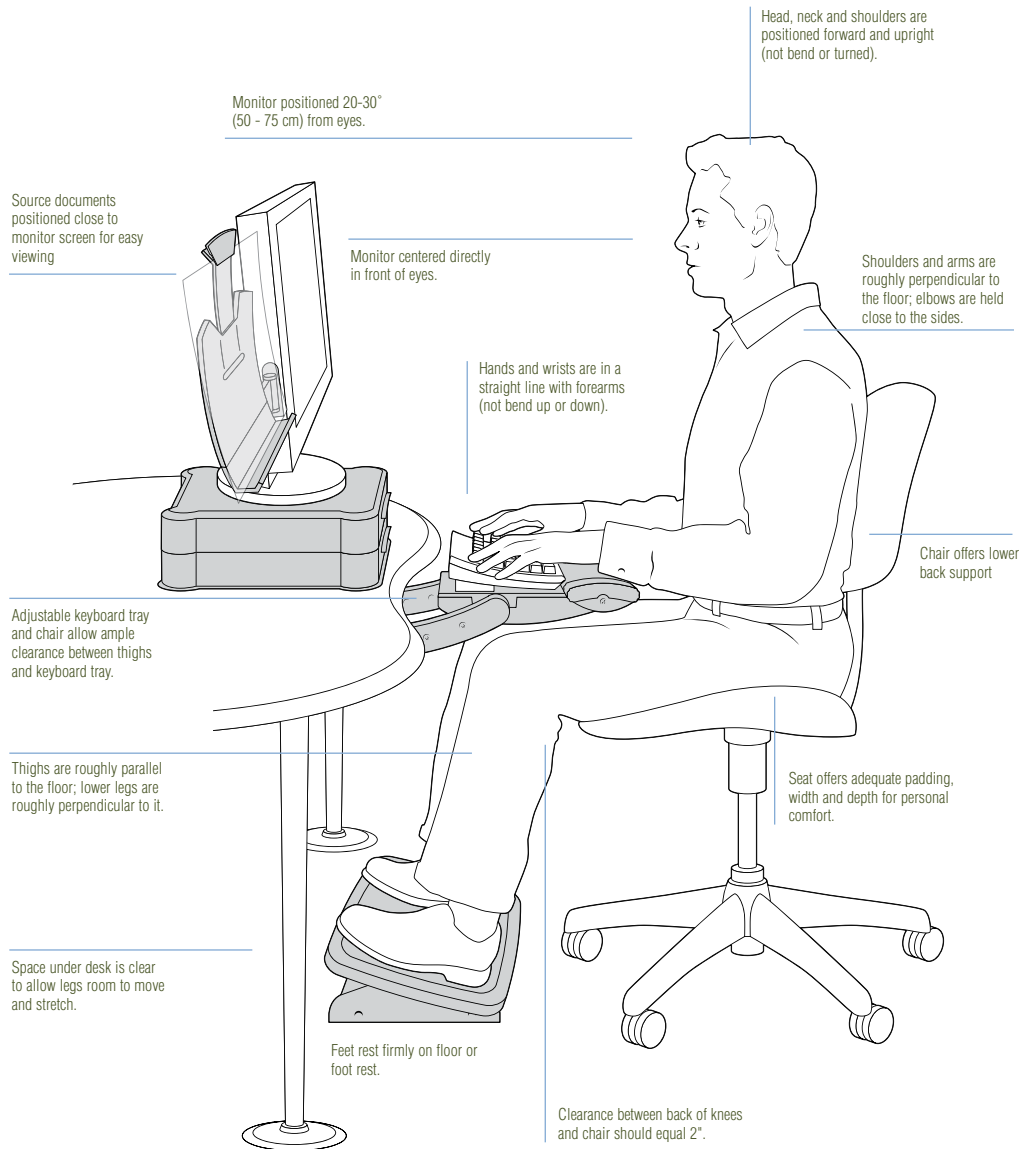



## Content

|  |       |
|--|-------|
| Adjustable Keyboard Trays .....                | 2-3   |
| Keyboard Drawers .....                         | 4     |
| Monitor Stands .....                           | 5     |
| Adjustable Foot Rests .....                    | 5     |
| Precise™ Optical Mousing Surfaces .....        | 5     |
| Gel Wrist Rests .....                          | 6     |
| Document Holders .....                         | 7     |
| Laptop Platform/Riser .....                    | 8     |
| Polarizing Task Light .....                    | 9     |
| Computer Filters .....                         | 10-11 |
| Work Surface Cleaners & Organisers .....       | 12    |
| Inspection Checklist For DSE Workstation ..... | 13    |

# 3M™ Adjustable Keyboard Trays

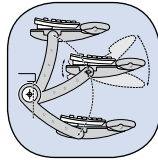

Outstanding stability and excellent knee clearance



Platform tilt adjustment

## AKT200LE

- Sit/stand feature allows alternation between sitting and standing
- Easily adjustable for height and tilt with unique dual arm with hand lever
- Gel wrist rests for keyboard and mouse platforms add comfort by minimizing pressure points.
- Features 3M™ Precise™ Optical Mousing Surface
- Adjustable mouse pad can mount left or right, tilt forward and backward
- Unlimited platform tilt range
- Maximum height above mounting surface is 7.5"
- Maximum depth below mounting surface is 9"

APTA

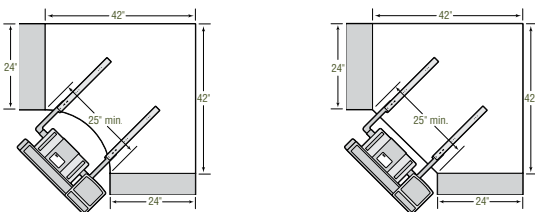
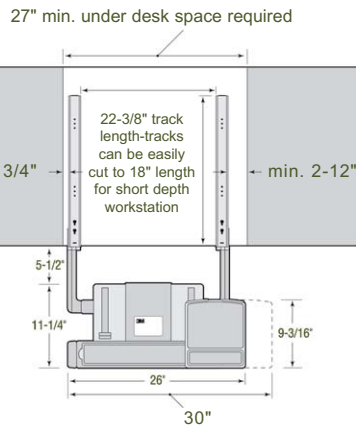
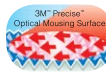

42" X 24" L Curved corner work surface

## AKT150LE

- Lever free lift and lock adjustable for height
- Keyboard platform can adjust left and right
- Gel wrist rests for keyboard and mouse platforms add comfort by minimizing pressure points.
- Features 3M™ Precise™ Optical Mousing Surface
- Adjustable mouse pad can mount left or right, tilt forward and backward
- Platform tilt range: +15°/-15°
- Maximum height above mounting surface is 0.5"
- Maximum depth below mounting surface is 6.75"



Lever-arm adjustment for height and pull-tab adjustment for tilt

## AKT100LE

- Platform tilt range: +10°/-15°
- Maximum height above mounting surface is 1"
- Maximum depth below mounting surface is 4.5"

APTA

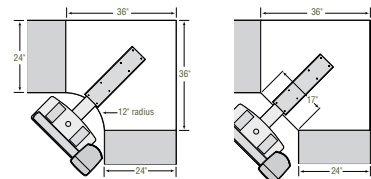
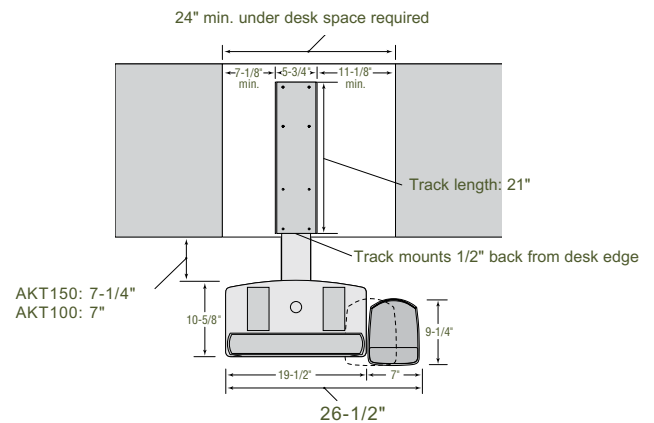
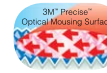

36" X 24" L Curved corner work surface

# 3M™ Adjustable Keyboard Trays



## AKT80LE

- Perfect for shallow workstations
- Gel wrist rests for keyboard and mouse platforms add comfort by minimizing pressure points.
- Features 3M™ Precise™ Optical Mousing Surface
- Adjustable mouse pad can mount left or right, tilt forward and backward
- Platform tilt range: +15°/-15°
- Maximum height above mounting surface is 1"
- Maximum depth below mounting surface is 4.5"

APTA

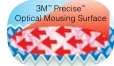

Star-knob adjustment controls height and tilt simultaneously



Adjustable separate mousing platform mounts left or right

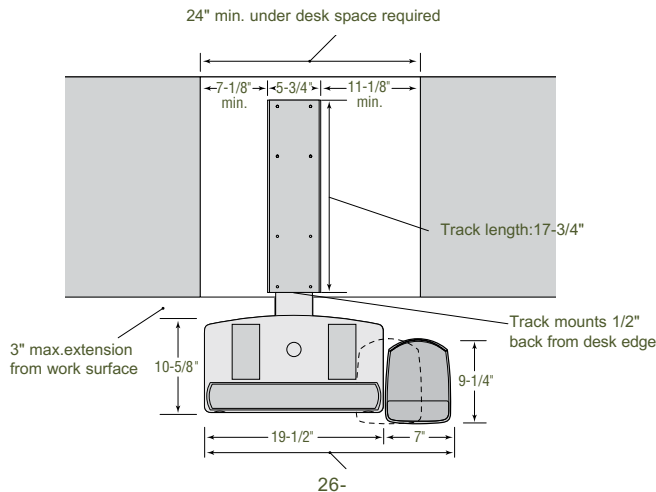

Star-knob adjustment controls height and tilt

## AKT60LE / AKT65LE

- Gel wrist rests for keyboard and mouse add comfort by minimizing pressure points.
- Basic single platform accommodates both keyboard and mouse.
- 3M™ Precise™ Optical Mousing Surface is positionable left or right
- Platform tilt range: +15°/-15°
- Maximum height above mounting surface is 1"
- Maximum depth below mounting surface is 4.5"

APTA

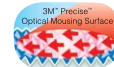

AKT65  
Tool free installation

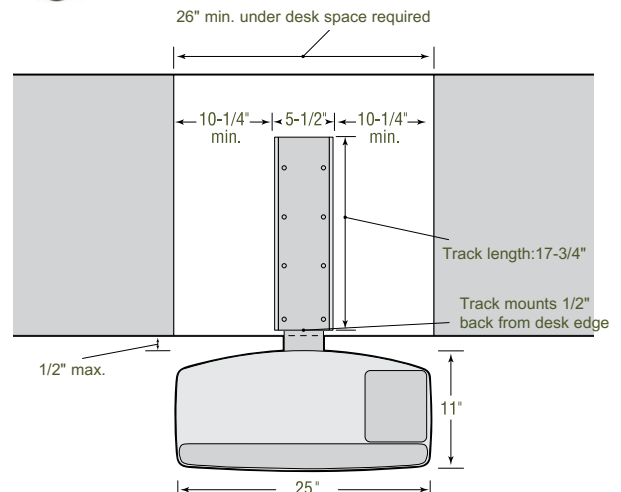



# 3M™ Keyboard Drawers

APTA

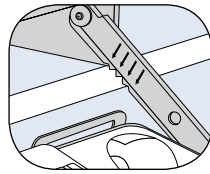
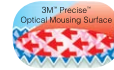

Height and tilt adjustment

## KD95CG Adjustable Desktop Keyboard Drawer

- Desktop design provides height and tilt adjustment up to 3.75" below desk level
- Adjustable keyboard platform and no installation required
- Gel wrist rests for keyboard and mouse add comfort by minimizing pressure points
- Features 3M™ Precise™ Optical Mousing Surface
- Steel reinforced construction and holds weight up to 80 lbs
- 27.9" x 16.8" x 4"



## KD45 Under-desk Keyboard Drawer

- Easy to install
- Under-desk design with three different positions to ensure correct height
- Gel wrist rests for keyboard and features 3M™ Precise™ Optical Mousing Surface
- 23.2" x 16.1" x 2.3"



## KD85CG

- No installation required
- Holds weight up to 80lbs
- Gel wrist rests for keyboard and features 3M™ Precise™ Optical Mousing Surface
- 27.5" x 18.8" x 4.1"

# 3M™ Monitor Stands

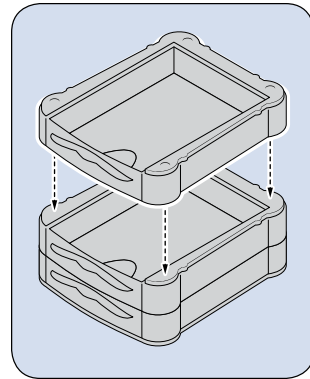

## MS101 Adjustable Monitor Stand

- Adjusts in increments of 1.5" and extra drawers available
- Sturdy construction supports monitors up to 21" or printers up to 80lbs
- 13.6" x 13.2" x 3"

## MS100CG

- Adjusts in increments of 1.5" and extra drawers available
- Sturdy construction supports monitors up to 21" or printers up to 80lbs
- 13.6" x 13.2" x 1.5"

# 3M™ Adjustable Foot Resets



- FR430: 18" x 13" x 4"
- FR430: 22" x 14" x 4"



## FR430/FR530

- Reduce strain and fatigue on legs, back and neck.
- Extra wide platform and heavy-duty steel construction for extra stability
- 3M™ Safety Walk™ Slip-Resistant Surface keeps feet from Sliding

# 3M™ Precise™ Optical Mousing Surfaces



MS201BE



MS201SG

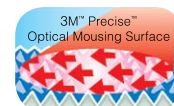

3M™ Precise™ Optical Mousing Surface is designed to enhance light reflectivity and contrast to improve the tracking of optical mouse

# 3M™ Gel Wrist Resets

## Wrists rest

- Wrist rests add comfort by minimizing pressure points
- Features 3M™ Precise™ Optical Mousing Surface to improve tracking of optical mouse
- Fabric material provides comfort



MW311(BE/CL/MB)  
8.7" x 9.2" x 0.8"

APTA

WR310(BE/MB/GY)  
19" x 2.8" x 0.8"

APTA

WR305(AB/BE/MB)  
5.3" x 2.3" x 0.7"

APTA

## Wrists rest

- Wrist rests add comfort by minimizing pressure points
- Features 3M™ Precise™ Optical Mousing Surface to improve tracking of optical mouse
- Clear gel for easy cleaning



WRJ320BE  
19" x 2.8" x 0.7"

APTA

MWJ309(BE/PP/GR)  
6.9" x 9" x 0.8"

APTA

WR302BH  
19" x 2.8" x 0.7"

MWJ309BH  
6.9" x 9" x 0.8"

APTA

## Gel Wrist Rest Platforms

- Tilt feature helps keep your wrists properly aligned and improves ergonomic posture.
- Features 3M™ Precise™ Optical Mousing Surface for WR421LE & WR422LE

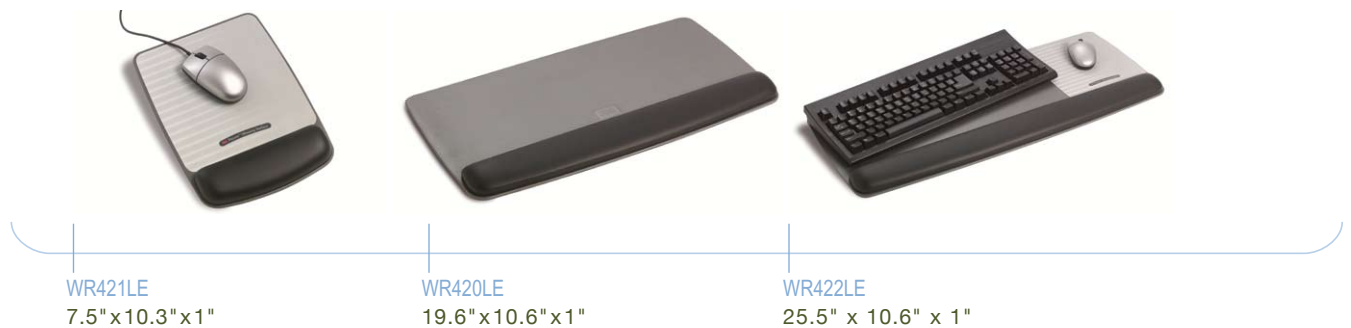

WR421LE  
7.5" x 10.3" x 1"

WR420LE  
19.6" x 10.6" x 1"

WR422LE  
25.5" x 10.6" x 1"



# 3M™ Document Holders

Document holders help reduce eye, neck and shoulder movement by keeping documents positioned as close to your computer monitor as possible



## DH540 Classic Document Holder

- Sheet capacity :150 sheets
- 6 adjustable ways
- 9.4" x 12" x 1.6"

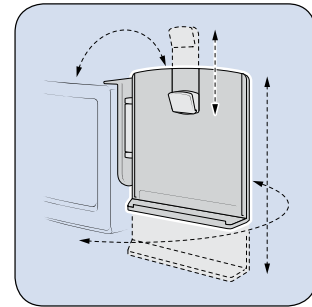

6 adjustable ways



## DH445 Flat Panel Document Holder

APTA

- Works with flat panel and CRT monitors
- Height adjustable clip secures sheets in portrait or landscape view
- Sheet capacity: 35 sheets
- 9" x 10" x 2.8"



## DH440MB Monitor Mount Document Holder for CRT Monitors

APTA

- Designed for mounting to full size CRT monitors.
- Height adjustable clip
- Sheet capacity: 150 sheets
- 9.4" x 12" x 1.6"



## DH240MB Document Clip

- Dual-functional clip
- Sheet capacity: 30 sheets
- 3" x 9" x 0.9"



DH445, DH440MB and DH240MB feature the Command™ Adhesive System that holds securely, yet removes cleanly, with no sticky adhesive residue



## DH340MB Desktop Document Holder

- Height adjustable clip
- Non skid base
- Sheet capacity: 150 sheets
- 9" x 12" x 1.6"



## DH640 In-Line Document Holder

- Position directly between monitor and keyboard
- Angle and height adjust to suit your needs
- Weighted base to support books and any size document
- Sheet capacity: 300 sheets
- 11" x 18" x 10"

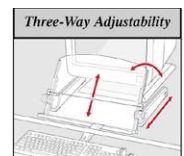

# 3M™ Laptop Platform/Riser



Height adjustable



## LX500 Adjustable notebook riser

- Height adjustable from 4-6 inches in ½" increments
- Cable management feature and compatible with docking stations
- Include side shelves and adapter for 3M™ DH445 document holder
- Supports up to 15 lbs
- 13" x 13" x 4"



## ANP560 Tilt Adjustable Notebook Platform

- Adjustable tilt platform promotes neutral wrist position
- Features Precise™ Mousing Surface and 3M™ Gel Wrist Rest
- Non-skid base and surface.



3" vertical adjustability



## LX550 Vertical notebook riser

- Position your notebook screen at an ergonomically correct height while taking up less space
- Riser has 3 inches of vertical adjustability and is compatible with most docking stations
- Non-skid base
- 8.5" x 10" x 9.5"

# 3M™ Polarizing Task Light



## 3M™ Polarizing Task Light Reduce glare effectively

- The 3M patented polarizing film can effectively reduce up to 80% of reflective glare. With a built-in diffuser design, 3M™ Polarizing Task Light can reduce direct glare and let you have the most comfortable light for reading.
- High quality aluminum reflector improves the brightness of the reflected light.
- Built-in inverter (electronic ballast) significantly increases the frequency of alternating current, which eliminates the stroboflash of 100 times per second and solves the acceleration of tiredness of eyes caused by the stroboflash of ray.
- Safety design for maximum security. It includes auto power off function when the light is fallen down or whenever the temperature becomes too high. (TL1000/QS1000/FX3800)

### TL1000



## 3M Patented Polarizing Technology Principle

- 3M Patented Polarizing Technology combines hundreds of alternating layers of high molecular plastic film, with its designated refractive index, to form a polarizing filter with thickness as thin as 132µm. It reduces glare effectively, yet keeping the light brightness for reading. (picture 1)
- The patented design allows only the vertical waves to transmit through the film, simultaneously reflecting and bouncing the horizontal waves until they turn into vertical waves and eventually transmit through the film. (picture 2)
- 3M's study on using the Polarizing Film on lamp and its function on improving reflective glare was reported by "The Journal of Applied Ergonomics" (Vol.32, No.5, 2001:485) in the United States.

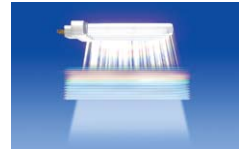

picture 1

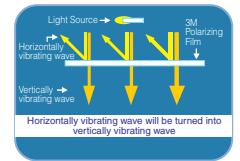

picture 2

### CL1000



- Base included
- Dual functions: Clamp or with base

CL1000SV

CL1000GY

### CL2000



CL2000SV

CL2000GY

### QS1000



QS1000GR

QS1000PK

QS1000BL

### FX3000 / FX3500



FX3000 OG

FX3000 AQ

FX3500 GR

FX3500 SV

### FX3800



FX3800BL

FX3800PK

FX3800GR

FX3800GY

### FL1000



FL1000SV

# 3M™ Computer Filters

## Anti-glare computer filter is one of the easiest, most effective ways for helping reduce the symptoms of CVS

Using a computer filter is one of the best ways to reduce the irritating effects of screen glare. In 1996, A Cornell University Study revealed that after using an anti-glare computer filter, the percentage of daily or weekly problems of Computer Vision Syndrome\* was half of what it was before using a filter. In addition, 80% of users reported that the filters made it easier to read their screens, more than 50% said the filters helped their productivity.

\* Computer Vision Syndrome (CVS) – according to The American Optometric Association, recognizes CVS as “eye and vision problems related to ‘near’ work which are experienced during, or related to, computer use.” Discomforts include eyestrain, headaches, dry or irritated eyes, neck and/or backaches and light sensitivity.

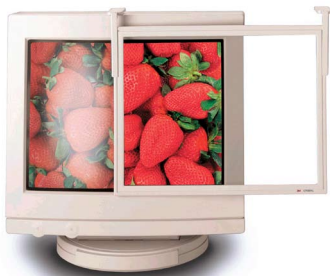

### 3M™ Standard Computer Filter (BF20 models)

- Reduce glare up to 90%, prevent glare-related eyestrain and headaches
- Blocks up to 99.9% of ELF/VLF E-field radiation
- Reduces static to help prevent dust buildup when properly grounded
- Sizes to fit 13" – 18" CRT monitors



### 3M™ Executive Computer Filter (EF200 models)

- Up to 99% glare reduction to help prevent eyestrain & headaches related to computer monitor use
- Blocks up to 99.9% ELF/VLF E-field radiation, reduces static & dust build-up
- ISO 9241-7 compliance and proven monitor performance improvement
- Suitable for home and office computer users
- Sizes to fit 14" – 21" CRT, and 15" – 20" LCD monitors



### 3M™ Privacy Computer Filter (PF400 models)

- 3M's privacy technology narrow the viewing area so that screen data is visible only to persons directly in front of the monitor
- Up to 95% screen glare reduction to help prevent eyestrain and headaches related to computer monitor use
- Sizes to fit 14" – 21" CRT, and 15" – 20" LCD monitors



### 3M™ Expressions Computer Filter (EX10 models)

- Designer black satin frame matches dark-colored monitors
- Reduces glare up to 90% to help prevent glare-related eyestrain & headaches related to computer monitor use
- Light tint glass for improved screen contrast
- Sizes to fit 14" – 19" CRT, and 15" – 18" LCD monitors



EF200, PF400 and EX10 models :  
Two separate sets of hanger arms  
allow flat frame filters to be used on  
either CRT or LCD monitors



# 3M™ Computer Filters



## 3M™ Notebook / LCD Protection Filter (AF models)

- Protect screen from fingerprints, scratches and damage
- Anti-glare coating and increased contrast
- Easy installation and removal – feature two different attachment methods that will meet most users' preferences
- Free Scotch-Brite High Performance Cloth for easy cleaning
- Sizes to fit 14.1", 15.0" and 17.0" Notebook / LCD monitors



## 3M™ Notebook / LCD Privacy Filter (PF models)

- Using 3M's privacy technology, screen data is visible only to persons directly in front of the monitor, from the side others see a black screen
- Allows travelers to work nearly anytime and anywhere by helping to protect confidential data
- Prevent scratches or damage to Notebook or LCD screen
- Easy to attach and remove; filter can be left in place even when your notebook is closed
- Free Scotch-Brite High Performance Cloth for easy cleaning
- Sizes to fit 12.1", 13.3", 14.1", 15.0", 17.0", 18.1" and 19.0" Notebook / LCD monitors



## 3M™ Mirror Film (MF model)

- 3M's unique transfective polarizing film performs a mirror function - high reflective with high transmission on LCD display
- Screen protection
- Free for size cutting
- Film size : 63mm x 82mm
- Applicable to flat color LCD display mobile phones



PF400 and PF models : 3M's patented micro-louver technology narrows the horizontal viewing angle to 60°. It blacks out screen images from a side view; passersby see only a dark, blank screen.



# Work Surface Cleaners & Organisers



## CL680 Screen and Keyboard Cleaning kit

- All in one kit including anti-static cleaning fluid
- Unique double-sided applicator, five replacement chamois wipes



## CL600 Anti-Static Electronic Equipment Cleaner

- Removes fingerprint, dirt, grease and dust from multiple electronic equipment and glass surfaces
- Streak free formula



## CL630 Notebook Screen Cleaning Wipes

- Removes dust, fingerprints and smudges from notebook computer screens
- 24 pre-moistened portable wipes



## CL610 Premoistened Anti-Static Wipes

- Great for CDs and DVDs.
- Non-abrasive and safe for use on multiple surfaces including wood, metal, plastic
- 80 count canister



## 573 General Purpose Cleaning Foam

- Safe for use on a variety of surfaces of both home and office furniture and equipment
- Special foaming action traps dust and won't drip for easy wipe away
- No waxy, oily residue
- Non-greasy, non-sticky



## Scotch® CD/DVD Lens Cleaner AV-101

- Removes dust and debris from the laser lens to optimize sound and video quality.
- Features "On disc" voice recording that guides the user through the cleaning process.

## Scotch® Bundling Wrap

- Repetitive use



RF8210  
1" x 72", Black



RF8111  
1/2" x 8", 6 pcs, Black



**3M Hong Kong Ltd**

5/F., Victoria Centre  
15 Watson Road  
North Point Hong Kong  
Tel: 2806 6111  
Fax: 2570 4734  
Website: [www.3M.com/hk/office](http://www.3M.com/hk/office)