



# **SOPC Builder**

---

## **User Guide**



101 Innovation Drive  
San Jose, CA 95134  
[www.altera.com](http://www.altera.com)

UG-01096-1.0



Subscribe

© 2010 Altera Corporation. All rights reserved. ALTERA, ARRIA, CYCLONE, HARDCOPY, MAX, MEGACORE, NIOS, QUARTUS and STRATIX are Reg. U.S. Pat. & Tm. Off. and/or trademarks of Altera Corporation in the U.S. and other countries. All other trademarks and service marks are the property of their respective holders as described at [www.altera.com/common/legal.html](http://www.altera.com/common/legal.html). Altera warrants performance of its semiconductor products to current specifications in accordance with Altera's standard warranty, but reserves the right to make changes to any products and services at any time without notice. Altera assumes no responsibility or liability arising out of the application or use of any information, product, or service described herein except as expressly agreed to in writing by Altera. Altera customers are advised to obtain the latest version of device specifications before relying on any published information and before placing orders for products or services.



## Chapter 1. Introduction to SOPC Builder

Architecture of SOPC Builder Systems .....	1-1
SOPC Builder Modules .....	1-2
Functions of SOPC Builder .....	1-5
Defining and Generating the System Hardware .....	1-5
Creating a Memory Map for Software Development .....	1-6
Creating a Simulation Model and Test Bench .....	1-6
SOPC Builder Design Flow .....	1-6
Visualization of SOPC Builder Systems .....	1-8
Operating System Support .....	1-8
Talkback Support .....	1-8

## Chapter 2. System Interconnect Fabric for Memory-Mapped Interfaces

High-Level Description .....	2-1
Fundamentals of Implementation .....	2-3
Functions of System Interconnect Fabric .....	2-3
Address Decoding .....	2-3
Datapath Multiplexing .....	2-4
Wait State Insertion .....	2-5
Pipelined Read Transfers .....	2-6
Dynamic Bus Sizing and Native Address Alignment .....	2-6
Dynamic Bus Sizing .....	2-7
Native Address Alignment .....	2-8
Arbitration for Multimaster Systems .....	2-9
Traditional Shared Bus Architectures .....	2-9
Slave-Side Arbitration .....	2-10
Arbiter Details .....	2-11
Arbitration Rules .....	2-12
Burst Adapters .....	2-14
Interrupts .....	2-15
Individual Requests IRQ Scheme .....	2-15
Priority Encoded Interrupt Scheme .....	2-15
Assigning IRQs in SOPC Builder .....	2-16
Reset Distribution .....	2-16

## Chapter 3. System Interconnect Fabric for Streaming Interfaces

High-Level Description .....	3-1
Avalon Streaming and Avalon Memory-Mapped Interfaces .....	3-2
Adapters .....	3-3
Data Format Adapter .....	3-4
Timing Adapter .....	3-4
Channel Adapter .....	3-5
Error Adapter .....	3-5
Multiplexer Examples .....	3-5
Example to Double Clock Frequency .....	3-6
Example to Double Data Width and Maintain Frequency .....	3-6
Example to Boost the Frequency .....	3-6

**Chapter 4. SOPC Builder Components**

Component Providers	4-1
Component Hardware Structure	4-2
Component Instances Inside the SOPC Builder System	4-2
Components Outside the SOPC Builder System	4-3
Exported Connection Points—Conduit Interfaces	4-3
SOPC Builder Component Search Path	4-4
Installing Additional Components	4-4
Copy to the IP Root Directory	4-5
Reference Components in an .ipx File	4-6
Understanding IPX File Syntax	4-7
Upgrading from Earlier Versions	4-8
Component Structure	4-8
Component Description File (_hw.tcl)	4-9
Component File Organization	4-9
Component Versioning	4-9
Classic Components in SOPC Builder	4-10

**Chapter 5. Using SOPC Builder with the Quartus II Software**

Quartus II IP File	5-1
Quartus II Incremental Compilation	5-1
TimeQuest Timing Analyzer	5-2
Analyzing PLLs	5-2
Analyzing Slow Asynchronous I/O Paths	5-3
Analyzing Single Data Rate SDRAM and SSRAM	5-4
Analyzing Tristate Bridges and Asynchronous Devices	5-6
Analyzing DDR and DDR2 Memories	5-7

**Chapter 6. Component Editor**

Component Hardware Structure	6-1
Starting the Component Editor	6-2
HDL Files Tab	6-2
Bottom-Up Design	6-2
Top-Down Design	6-3
Signals Tab	6-3
Naming Signals for Automatic Type and Interface Recognition	6-4
Templates for Interfaces to External Logic	6-5
Interfaces Tab	6-6
HDL Parameters Tab	6-6
Library Info	6-7
Saving a Component	6-7
Editing a Component	6-8
Software Assignments	6-8
Component Parameterization	6-8

**Chapter 7. Component Interface Tcl Reference**

Information in a Hardware Component Description File	7-1
Component Phases	7-2
Writing a Hardware Component Description File	7-2
Providing Basic Information	7-3
Declaring Parameters	7-3
Declaring Interfaces	7-5
Adding Files and Guiding Generation	7-5

Default Behaviors .....	7-6
Validation Phase Behavior .....	7-6
Elaboration Phase Behavior .....	7-6
Generation Phase Behavior .....	7-7
Edit Phase Behavior .....	7-7
Overriding Default Behaviors .....	7-8
Validation Callback .....	7-9
Elaboration Callback .....	7-9
Generation Callback .....	7-10
Editor Callback .....	7-11
Hardware Tcl Command Reference .....	7-12
Module Definition .....	7-14
Parameters .....	7-21
Display Items .....	7-29
Interfaces and Ports .....	7-32
Generation .....	7-38
Deprecated Commands and Properties .....	7-40

## Chapter 8. Archiving SOPC Builder Projects

Limitations .....	8-1
Required Files .....	8-2

## Chapter 9. SOPC Builder Memory Subsystem Development Walkthrough

Example Design .....	9-1
Example Design Starting Point .....	9-3
Hardware and Software Requirements .....	9-3
Design Flow .....	9-4
Component-Level Design in SOPC Builder .....	9-4
SOPC Builder System-Level Design .....	9-4
Simulation .....	9-5
Quartus II Project-Level Design .....	9-5
Board-Level Design .....	9-5
Simulation Considerations .....	9-5
On-Chip RAM and ROM .....	9-6
Component-Level Design for On-Chip Memory .....	9-6
SOPC Builder System-Level Design for On-Chip Memory .....	9-8
Simulation for On-Chip Memory .....	9-8
Quartus II Project-Level Design for On-Chip Memory .....	9-8
Board-Level Design for On-Chip Memory .....	9-8
Example Design with On-Chip Memory .....	9-8
EPCS Serial Configuration Device .....	9-9
Component-Level Design for an EPCS Device .....	9-9
SOPC Builder System-Level Design for an EPCS Device .....	9-9
Simulation for an EPCS Device .....	9-9
Quartus II Project-Level Design for an EPCS Device .....	9-10
Board-Level Design for an EPCS Device .....	9-10
Example Design with an EPCS Device .....	9-10
SDR SDRAM .....	9-11
Component-Level Design for SDRAM .....	9-11
SOPC Builder System-Level Design for SDRAM .....	9-11
Simulation for SDRAM .....	9-11
Quartus II Project-Level Design for SDRAM .....	9-12
Board-Level Design for SDRAM .....	9-12

Example Design with SDR SDRAM .....	9-12
DDR SDRAM .....	9-14
DDR2 SDRAM .....	9-14
Off-Chip SRAM and Flash Memory .....	9-15
Component-Level Design for SRAM and Flash Memory .....	9-15
SOPC Builder System-Level Design for SRAM and Flash Memory .....	9-17
Simulation for SRAM and Flash Memory .....	9-17
Quartus II Project-Level Design for SRAM and Flash Memory .....	9-18
Board-Level Design for SRAM and Flash Memory .....	9-18
Example Design with SRAM and Flash Memory .....	9-20
<b>Chapter 10. SOPC Builder Component Development Walkthrough</b>	
SOPC Builder Components and the Component Editor .....	10-1
Prerequisites .....	10-1
Hardware and Software Requirements .....	10-2
Component Development Flow .....	10-2
Typical Design Steps .....	10-2
Hardware Design .....	10-3
Design Example: Checksum Hardware Accelerator .....	10-4
Software Design .....	10-6
Verifying the Component .....	10-6
Sharing Components .....	10-7
System Information Files (.sopcinfo) .....	10-7
<b>Chapter 11. Avalon Memory-Mapped Bridges</b>	
Structure of a Bridge .....	11-2
Reasons for Using a Bridge .....	11-2
Address Mapping for Systems with Avalon-MM Bridges .....	11-6
Avalon-MM Pipeline Bridge .....	11-8
Component Overview .....	11-9
Functional Description .....	11-10
Clock Crossing Bridge .....	11-12
Choosing Clock Crossing Methodology .....	11-13
Functional Description .....	11-13
Instantiating the Avalon-MM Clock-Crossing Bridge in SOPC Builder .....	11-17
Clock Domain Crossing Logic .....	11-17
Description of Clock Domain Adapter .....	11-18
Location of Clock Domain Adapter .....	11-19
Duration of Transfers Crossing Clock Domains .....	11-19
Implementing Multiple Clock Domains in SOPC Builder .....	11-20
Avalon-MM DDR Memory Half-Rate Bridge .....	11-20
Resource Usage and Performance .....	11-21
Functional Description .....	11-22
Instantiating the Core in SOPC Builder .....	11-23
Example System .....	11-24
Device Support .....	11-25
Hardware Simulation Considerations .....	11-25
Software Programming Model .....	11-25
<b>Chapter 12. Avalon Streaming Interconnect Components</b>	
Interconnect Component Usage .....	12-1
Address Mapping .....	12-2
Timing Adapter .....	12-2

---

Resource Usage and Performance .....	12-4
Instantiating the Timing Adapter in SOPC Builder .....	12-4
Data Format Adapter .....	12-5
Resource Usage and Performance .....	12-6
Instantiating the Data Format Adapter in SOPC Builder .....	12-6
Channel Adapter .....	12-7
Resource Usage and Performance .....	12-8
Instantiating the Channel Adapter in SOPC Builder .....	12-8
Error Adapter .....	12-9
Instantiating the Error Adapter in SOPC Builder .....	12-9
Installation and Licensing .....	12-10
Hardware Simulation Considerations .....	12-10
Software Programming Model .....	12-10

**Additional Information**

Document Revision History .....	Info-1
How to Contact Altera .....	Info-1
Typographic Conventions .....	Info-1





SOPC Builder is a powerful system development tool. SOPC Builder enables you to define and generate a complete system-on-a-programmable-chip (SOPC) in much less time than using traditional, manual integration methods. SOPC Builder is included as part of the Quartus II software. For a quick introduction on how to use SOPC Builder, follow these general steps:

- Install the Quartus® II software, which includes SOPC Builder. This is available at [www.altera.com](http://www.altera.com).
- Take advantage of the one-hour online course, *Using SOPC Builder*.
- Download and run the checksum sample design described in [Chapter 9, SOPC Builder Memory Subsystem Development Walkthrough](#).

You may have used SOPC Builder to create systems based on the Nios® II processor. However, SOPC Builder is more than a Nios II system builder; it is a general-purpose tool for creating systems that may or may not contain a processor and may include a soft processor other than the Nios II processor.

SOPC Builder automates the task of integrating hardware components. Using traditional design methods, you must manually write HDL modules to wire together the pieces of the system. Using SOPC Builder, you specify the system components in a GUI and SOPC Builder generates the interconnect logic automatically. SOPC Builder generates HDL files that define all components of the system, and a top-level HDL file that connects all the components together. SOPC Builder generates either Verilog HDL or VHDL equally.

In addition to its role as a system generation tool, SOPC Builder provides features to ease writing software and to accelerate system simulation. This chapter includes the following sections:

- “Architecture of SOPC Builder Systems” on page 1-1
- “Functions of SOPC Builder” on page 1-5
- “Operating System Support” on page 1-8
- “Talkback Support” on page 1-8

## Architecture of SOPC Builder Systems

An SOPC Builder component is a design module that SOPC Builder recognizes and can automatically integrate into a system. You can also define and add custom components or select from a list of provided components. SOPC Builder connects multiple modules together to create a top-level HDL file called the SOPC Builder system. SOPC Builder generates system interconnect fabric that contains logic to manage the connectivity of all modules in the system.

## SOPC Builder Modules

 This document refers to *components* as the class definition for a module, for example a Nios® II processor. An *instance* is a parameterization of a component that's been added to a system, for example `cpu_0`.

SOPC Builder modules are the building blocks for creating an SOPC Builder system. SOPC Builder modules use Avalon® interfaces, such as memory-mapped, streaming, and IRQ, for the physical connection of components. You can use SOPC Builder to connect any logical device (either on-chip or off-chip) that has an Avalon interface. There are different types of Avalon interfaces, as described in the *Avalon Interface Specifications*.

 For details on the Avalon-MM interface refer to [Chapter 2, System Interconnect Fabric for Memory-Mapped Interfaces](#). For details on the Avalon-ST interface, refer to [Chapter 3, System Interconnect Fabric for Streaming Interfaces](#). For details about the Avalon-ST interface protocol, refer to *Avalon Interface Specifications*.

## Example System

Figure 1-1 shows an FPGA design that includes an SOPC Builder system and custom logic modules. You can integrate custom logic inside or outside the SOPC Builder system. In this example, the custom component inside the SOPC Builder system communicates with other modules through an Avalon-MM master interface. The custom logic outside of the SOPC Builder system is connected to the SOPC Builder system through a PIO interface. The SOPC Builder system includes two SOPC Builder components with Avalon-ST source and sink interfaces. The system interconnect fabric connects all of the SOPC Builder components using the Avalon-MM or Avalon-ST system interconnect as appropriate.

Figure 1-1. Example of an FPGA with a SOPC Builder System Generated by SOPC Builder

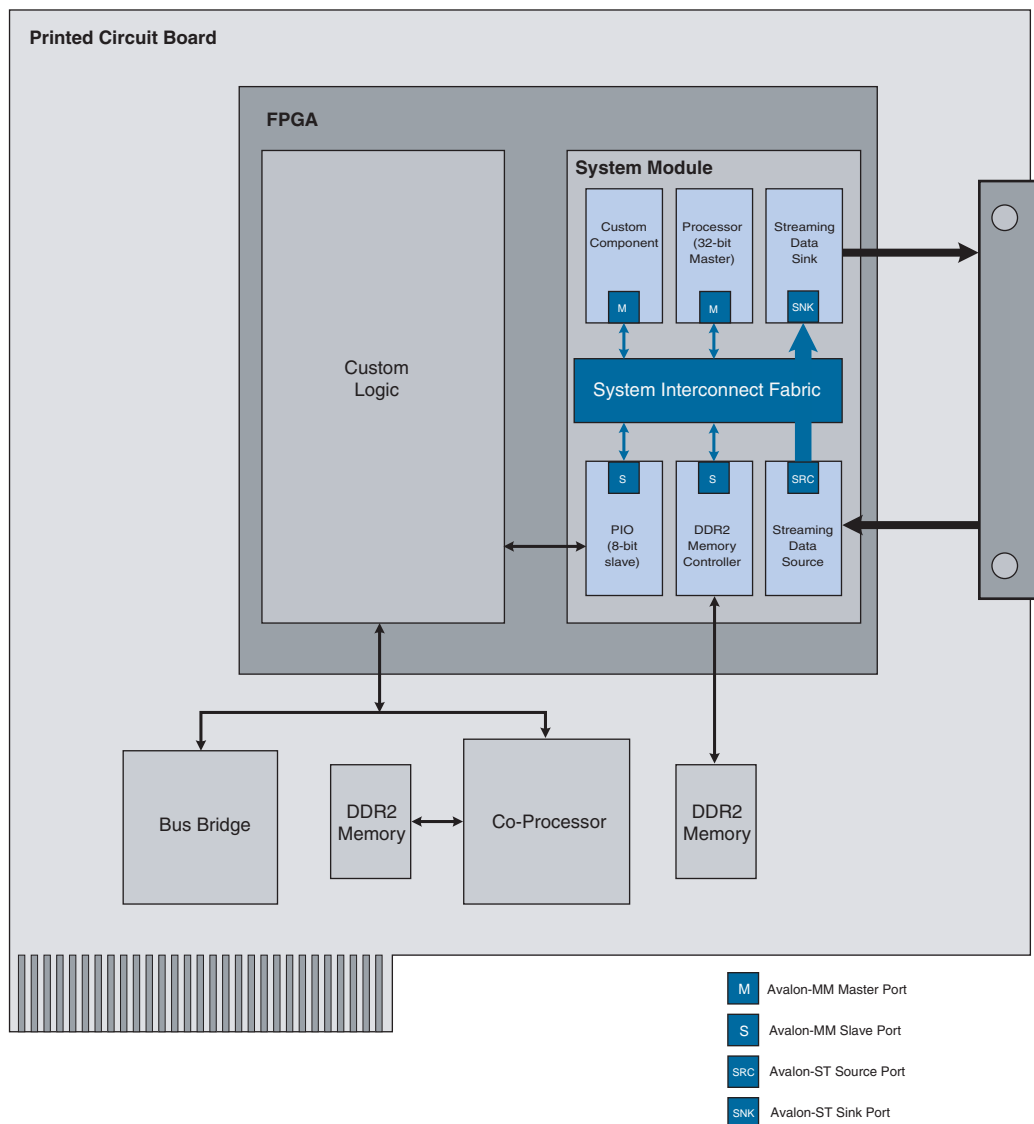

A component can be a logical device that is entirely contained within the SOPC Builder system, such as the processor component shown in [Figure 1-1](#). Alternately, a component can act as an interface to an off-chip device, such as the DDR2 interface component in [Figure 1-1](#). In addition to the Avalon interface, a component can have other signals that connect to logic outside the SOPC Builder system. Non-Avalon signals can provide a special-purpose interface to the SOPC Builder system, such as the PIO in [Figure 1-1](#). These non-Avalon signals are described in *Conduit Interface* chapter in the *Avalon Interface Specifications*.

## Available Components

[Altera](#) and third-party developers provide ready-to-use SOPC Builder components, including:



- Microprocessors, such as the Nios II processor
- Microcontroller peripherals, such as a Scatter-Gather DMA Controller and timer
- Serial communication interfaces, such as a UART and a serial peripheral interface (SPI)
- General purpose I/O
- Communications peripherals, such as a 10/100/1000 Ethernet MAC
- Interfaces to off-chip devices

## Custom Components

You can import HDL modules and entities that you write using Verilog HDL or VHDL into SOPC builder as custom components. You use the following design flow to integrate custom logic into an SOPC Builder system:

1. Determine the interfaces used to interact with your custom component.
2. Create the component logic using either Verilog HDL or VHDL.
3. Use the SOPC Builder component editor to create an SOPC Builder component with your HDL files.
4. Instantiate your component in the system.

Once you have created an SOPC Builder component, you can use the component in other SOPC Builder systems, and share the component with other design teams.

-  For instructions on developing a custom SOPC Builder component, the details about the file structure of a component, or the component editor, refer to [Chapter 4, SOPC Builder Components](#).
-  For details on the Avalon-MM interface refer to [Chapter 2, System Interconnect Fabric for Memory-Mapped Interfaces](#). For details on the Avalon-ST interface, refer to [Chapter 3, System Interconnect Fabric for Streaming Interfaces](#).

## Third-Party Components

You can also use SOPC-ready components that were developed by third-parties. Altera awards the SOPC Builder Ready certification to IP functions that are ready to integrate with the Nios II embedded processor or the system interconnect fabric via SOPC Builder. These cores support the Avalon-MM interface or the Avalon Streaming (Avalon-ST) interface and may include constraints, software drivers, simulation models, and reference designs when applicable.

To find SOPC Builder Ready third-party components that you can purchase and use in SOPC Builder systems, complete the following steps:

1. On the Tools menu in SOPC Builder, click **Download Components**.
2. On the [Intellectual Property Solutions](#) web page, type SOPC Builder ready ↵ in the box labeled **Search for IP, Development Kits and Reference Designs**.

## Functions of SOPC Builder

This section describes the functions of SOPC Builder.

### Defining and Generating the System Hardware

SOPC Builder allows you to design the structure of a hardware system. The GUI allows you to add components to a system, configure the components, and specify connectivity.

After you add and parameterize components, SOPC Builder generates the system interconnect fabric, and outputs HDL files to your project directory. During system generation, SOPC Builder creates the following items:

- An HDL file for the top-level SOPC Builder system and for each component in the system. The top-level HDL file is named `<system_name>.v` for Verilog HDL designs and `<system_name>.vhd` for VHDL designs.
- Synopsis Design Constraints file (`.sdc`) for timing analysis.
- A Block Symbol File (`.bsf`) representation of the top-level SOPC Builder system for use in Quartus II Block Diagram Files (`.bdf`).
- An example of an instance of the top-level HDL file, `<SOPC_project_name_inst>.v` or `<SOPC_project_name_inst>.vhd`, which demonstrates how to instantiate the top-level HDL file in your code.
- A data sheet called `<system_name>.html` that provides a system overview including the following information:
  - All external connections for the system
  - A memory map showing the address of each Avalon-MM slave with respect to each Avalon-MM master to which it is connected
  - All parameter assignments for each component
- A functional test bench for the SOPC Builder system and ModelSim® simulation project files

- SOPC information file (**.sopcinfo**) that describes all of the components and connections in your system. This file is a complete system description, and is used by downstream tools such as the Nios II tool chain. It also describes the parameterization of each component in the system; consequently, you can parse its contents to get requirements when developing software drivers for SOPC Builder components.
- A Quartus II IP File (**.qip**) that provides the Quartus II software with all required information about your SOPC Builder system. The **.qip** file includes references to the following information:
  - HDL files used in the SOPC Builder system
  - TimeQuest Timing Analyzer Synopsys Design Constraint (**.sdc**) files
  - Component definition files for archiving purposes

After you generate the SOPC Builder system, you can compile it with the Quartus II software, or you can instantiate it in a larger FPGA design.

## Creating a Memory Map for Software Development

When your SOPC Builder system includes a Nios II processor, SOPC Builder generates a header file, **cpu.h**, that provides the base address of each Avalon-MM slave component. In addition, each slave component can provide software drivers and other software functions and libraries for the processor. You can create C header files for your system using the `sopc-create-header-files` utility.

 For details type `sopc-create-header-files --help` in a Nios II Command shell.

 For more details about how to provide Nios II software drivers for components, refer to the *Developing Device Drivers for the Hardware Abstraction Layer* chapter of the *Nios II Software Developer's Handbook*. The Nios II EDS is separate from SOPC Builder, but it uses the output of SOPC Builder as the foundation for software development.

## Creating a Simulation Model and Test Bench

You can simulate your system after generating it with SOPC Builder. During system generation, SOPC Builder outputs a simulation test bench and a ModelSim setup script that eases the system simulation effort. The test bench does the following:

- Instantiates the SOPC Builder system
- Drives all clocks and resets
- Instantiates simulation models for off-chip devices when available

## SOPC Builder Design Flow

Figure 1-2 illustrates an example bottom-up design flow in SOPC Builder which starts with component design. As this flow diagram illustrates, the typical design flow includes the following high-level steps:

1. Package your component for SOPC Builder using the Component Editor.

2. Simulate at the unit-level, possibly incorporating Avalon BFM's to verify the system.
3. Complete the SOPC Builder design by adding other components, specifying interrupts, clocks, resets, and addresses.
4. Generate the SOPC Builder system.
5. Perform system level simulation.
6. Constrain and compile the design.
7. Download the design to an Altera device.
8. Test in hardware.

Figure 1-2. Complete Qsys Design Flow

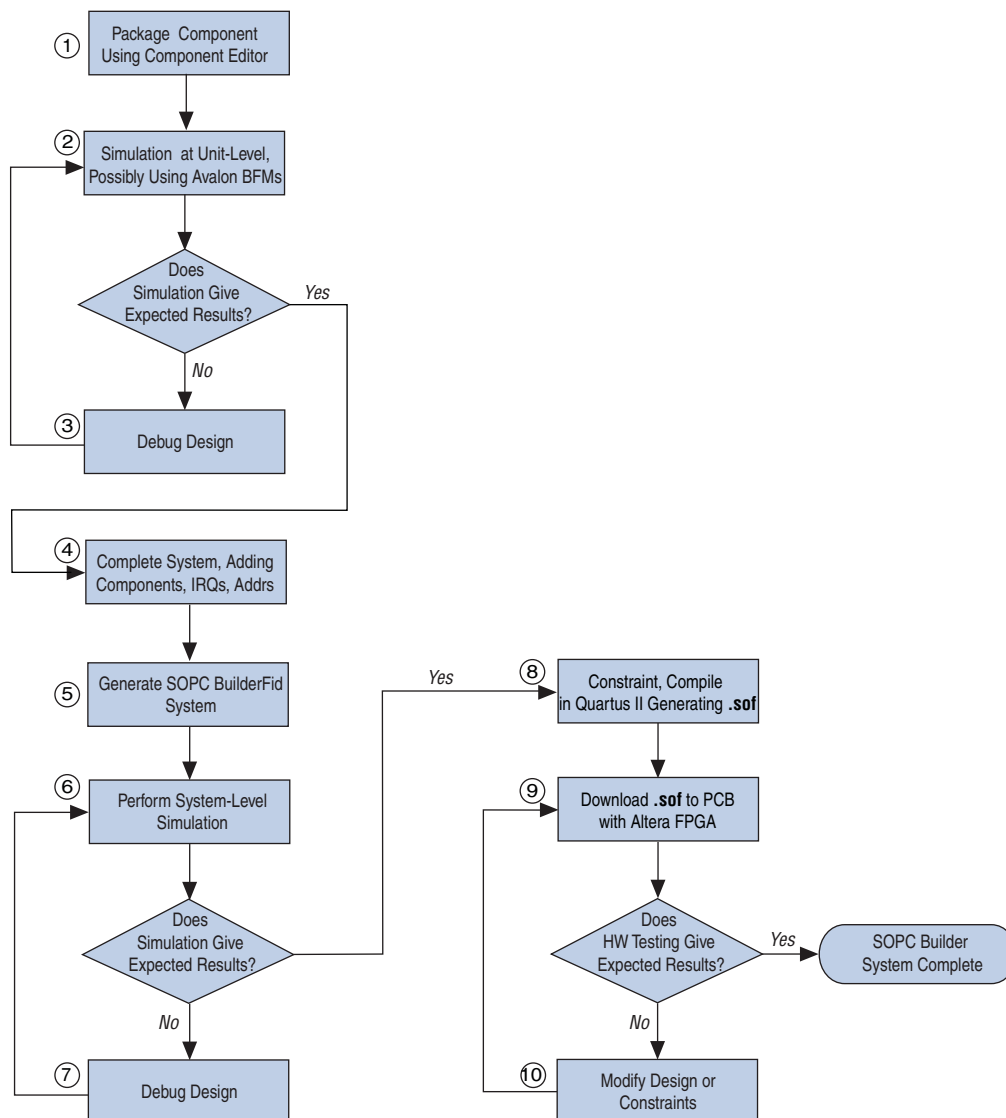

 In the alternative top-down valid design flow, you begin by designing the SOPC Builder system and then define and instantiate custom SOPC Builder component. This approach clarifies the system requirements earlier in the design process.

Designs targeting HardCopy devices require specific design constraints. Consequently, if you are targeting a HardCopy series device, you must verify your design for the HardCopy companion device.

Follow these guidelines to verify your design for both devices:

1. In the Quartus II **Device** dialog box, select both the FPGA and the appropriate HardCopy companion device.
2. In Step 8 of the design flow shown in [Figure 1-2](#), compile for both the FPGA and HardCopy device.
3. After Step 10 of the design flow shown in [Figure 1-2](#), if FPGA passes all functional simulation and hardware verification tests, generate the HardCopy handoff archive and send this archive to the HardCopy Design Center for the backend flow and tapeout.

## Visualization of SOPC Builder Systems

You can use the **Filters** dialog box to customize the display of your system in the connections panel. You can filter the display of your system by interface type, instance name, interface type, or using custom tags. For example, you can use filtering to view only instances that include an Avalon-MM interface or instances that are connected to a particular Nios II processor. For more information, refer to Quartus II online Help.

## Operating System Support

SOPC Builder supports all of the operating systems that the Quartus II software supports.

 For details on installation and licensing, refer to the [Altera Software Installation and Licensing Manual](#).

## Talkback Support

Talkback is a Quartus II software feature that provides feedback to Altera on tool and IP feature usage. Altera uses the data to help guide future product planning efforts. Talkback sends Altera information on the Altera components you use, including: interface types, interface properties, parameter names and values, clocking, and software assignments. For components from Altera, Talkback sends the component parameter values to help understand what features of the component are being used. For non-Altera components, Talkback collects information about how interfaces such as Avalon-MM are being used. Connectivity between components is not sent. The Talkback file does not include information about system connectivity, interrupts, or the memory map seen by each master in the system. Talkback collects the same very general information about your proprietary components.

The Talkback feature is enabled by default. You can disable Talkback from within the Quartus II software if you do not wish to share your usage data with Altera.



The system interconnect fabric for memory-mapped interfaces is a high-bandwidth interconnect structure for connecting components that use the Avalon<sup>®</sup> Memory-Mapped (Avalon-MM) interface. The system interconnect fabric consumes less logic, provides greater flexibility, and higher throughput than a typical shared system bus. It is a cross-connect fabric and not a tristated or time domain multiplexed bus. This chapter describes the functions of system interconnect fabric for memory-mapped interfaces and the implementation of those functions.

### High-Level Description

The system interconnect fabric is the collection of interconnect and logic resources that connects Avalon-MM master and slaves on components in a system. SOPC Builder generates the system interconnect fabric to match the needs of the components in a system. The system interconnect fabric implements the connection details of a system. It guarantees that signals are routed correctly between master and slaves, as long as the ports adhere to the rules of the *Avalon Interface Specifications*. This chapter provides information on the following topics:

- “Address Decoding” on page 2-3
- “Datapath Multiplexing” on page 2-4
- “Wait State Insertion” on page 2-5
- “Pipelined Read Transfers” on page 2-6
- “Dynamic Bus Sizing and Native Address Alignment” on page 2-6
- “Arbitration for Multimaster Systems” on page 2-9
- “Burst Adapters” on page 2-14
- “Interrupts” on page 2-15
- “Reset Distribution” on page 2-16

 For details about the Avalon-MM interface, refer to the *Avalon Interface Specifications*.

System interconnect fabric for memory-mapped interfaces supports the following items:

- Any number of master and slave components. The master-to-slave relationship can be one-to-one, one-to-many, many-to-one, or many-to-many.
- On-chip components.
- Interfaces to off-chip devices.
- Master and slaves of different data widths.
- Components operating in different clock domains.
- Components using multiple Avalon-MM ports.

Figure 2-1 shows a simplified diagram of the system interconnect fabric in an example memory-mapped system with multiple masters.



All figures in this chapter are simplified to show only the particular function being discussed. In a complete system, the system interconnect fabric might alter the address, data, and control paths beyond what is shown in any one particular figure.

**Figure 2-1. System Interconnect Fabric—Example System**

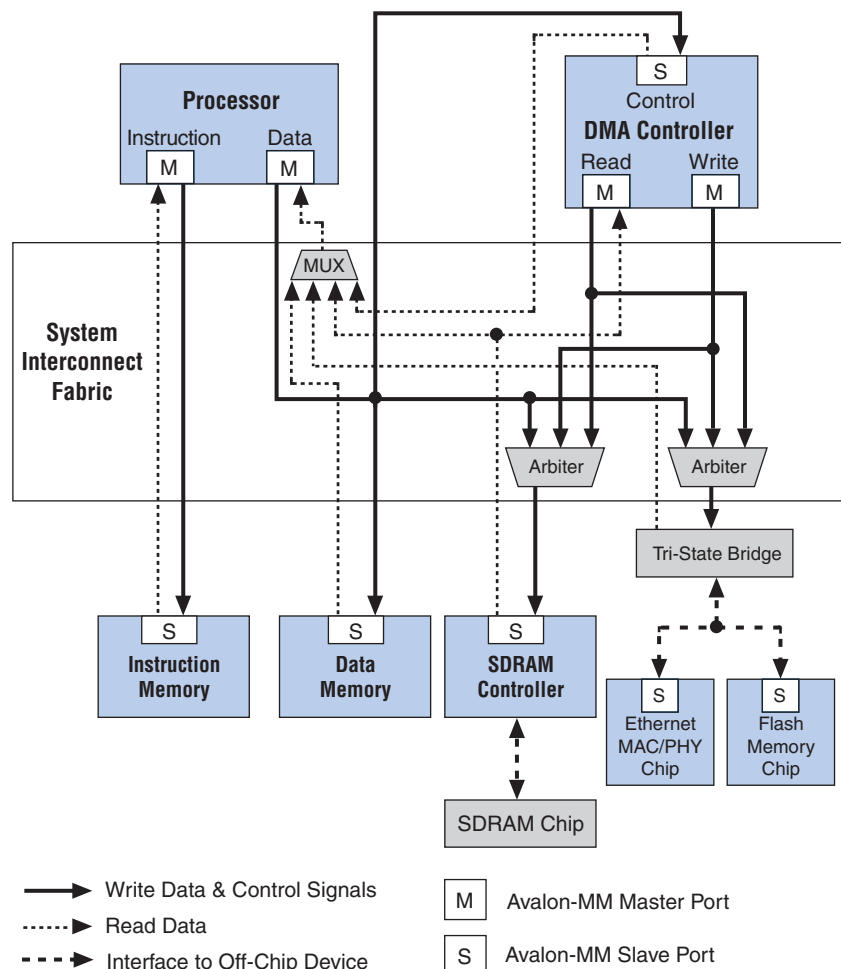

SOPC Builder supports components with multiple Avalon-MM interfaces, such as the processor component shown in Figure 2-1. Because SOPC Builder can create system interconnect fabric to connect components with multiple interfaces, you can create complex interfaces that provide more functionality than a single Avalon-MM interface. For example, you can create a component with two different Avalon-MM slaves, each with an associated interrupt interface.

System interconnect fabric can connect any combination of components, as long as each interface conforms to the *Avalon Interface Specifications*. It can, for example, connect a system comprised of only two components with unidirectional dataflow between them. Avalon-MM interfaces are suitable for random address transactions, such as to memories or embedded peripherals.

Generating system interconnect fabric is SOPC Builder's primary purpose. In most cases, you are not required to modify the generated HDL; however, a basic understanding of how HDL works can help you optimize your system. For example, knowledge of the arbitration algorithm can help designers of multimaster systems minimize the impact of arbitration on the system throughput.

## Fundamentals of Implementation

System interconnect fabric for memory-mapped interfaces implements a partial crossbar interconnect structure that provides concurrent paths between master and slaves. System interconnect fabric consists of synchronous logic and routing resources inside the FPGA.

For each component interface, system interconnect fabric manages Avalon-MM transfers, interacting with signals on the connected component. Master and slave interfaces can contain different signals and the system interconnect fabric handle any adaptation necessary between them. In the path between master and slaves, the system interconnect fabric might introduce registers for timing synchronization, finite state machines for event sequencing, or nothing at all, depending on the services required by the specific interfaces.



For more information, refer to the *Avalon Memory-Mapped Design Optimizations* chapter in the *Embedded Design Handbook*.

## Functions of System Interconnect Fabric

System interconnect fabric logic provides the following functions:

- "Address Decoding" on page 2-3
- "Datapath Multiplexing" on page 2-4
- "Wait State Insertion" on page 2-5
- "Pipelined Read Transfers" on page 2-6
- "Arbitration for Multimaster Systems" on page 2-9
- "Burst Adapters" on page 2-14
- "Interrupts" on page 2-15
- "Reset Distribution" on page 2-16

The behavior of these functions in a specific SOPC Builder system depends on the design of the components in the system and the settings made in SOPC Builder. The remaining sections of this chapter describe how SOPC Builder implements each function.

## Address Decoding

Address decoding logic in the system interconnect fabric forwards appropriate addresses to each slave. Address decoding logic simplifies component design in the following ways:

- The system interconnect fabric selects a slave whenever it is being addressed by a master. Slave components do not need to decode the address to determine when they are selected.
- Slave addresses are properly aligned to the slave interface.
- Changing the system memory map does not involve manually editing HDL.

Figure 2-2 shows a block diagram of the address-decoding logic for one master and two slaves. Separate address-decoding logic is generated for every master in a system.

As Figure 2-2 shows, the address decoding logic handles the difference between the master address width ( $\langle M \rangle$ ) and the individual slave address widths ( $\langle S \rangle$  and  $\langle T \rangle$ ). It also maps only the necessary master address bits to access words in each slave's address space.

**Figure 2-2. Block Diagram of Address Decoding Logic**

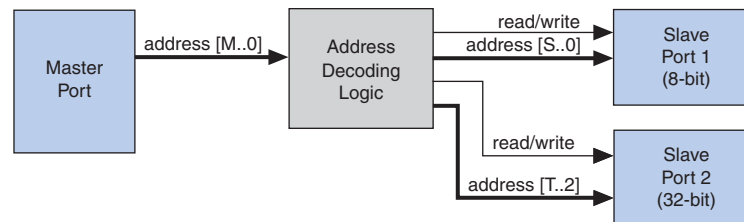

In SOPC Builder, the user-configurable aspects of address decoding logic are controlled by the **Base** setting in the list of active components on the **System Contents** tab, as shown in Figure 2-3.

**Figure 2-3. Base Settings in SOPC Builder Control Address Decoding**

Module Name	Description	Base	End	IRQ
cpu	Nios II Proces...			
instruction_master	Master port			
data_master	Master port			
jtag_debug_mod...	Slave port	0x02120000	0x021207FF	
ext_flash	Flash Memory...	0x00000000	0x007FFFFFFF	
ext_ram	IDT71V416 S...	0x02000000	0x020FFFFFFF	
ext_ram_bus	Avalon Tri-St...			
button_pio	PIO (Parallel I/O)	0x02120860	0x0212086F	2
high_res_timer	Interval timer	0x02120820	0x0212083F	3

## Datapath Multiplexing

Datapath multiplexing logic in the system interconnect fabric drives the `writedata` signal from the granted master to the selected slave, and the `readdata` signal from the selected slave back to the requesting master.

Figure 2-4 shows a block diagram of the datapath multiplexing logic for one master and two slaves. SOPC Builder generates separate datapath multiplexing logic for every master in the system.

**Figure 2-4. Block Diagram of Datapath Multiplexing Logic**

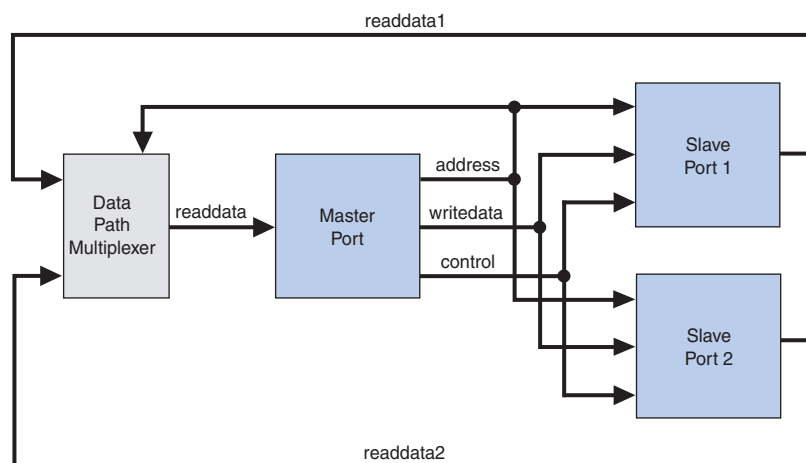

In SOPC Builder, the generation of datapath multiplexing logic is specified using the connections panel on the **System Contents** tab.

## Wait State Insertion

Wait states extend the duration of a transfer by one or more cycles. Wait state insertion logic accommodates the timing needs of each slave, and causes the master to wait until the slave can proceed. System interconnect fabric inserts wait states into a transfer when the target slave cannot respond in a single clock cycle. System interconnect fabric also inserts wait states in cases when slave `read_enable` and `write_enable` signals have setup or hold time requirements.

Wait state insertion logic is a small finite-state machine that translates control signal sequencing between the slave side and the master side. Figure 2-5 shows a block diagram of the wait state insertion logic between one master and one slave.

**Figure 2-5. Block Diagram of Wait State Insertion Logic**

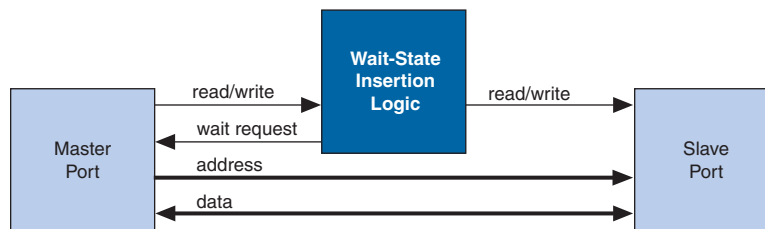

System interconnect fabric can force a master to wait for several reasons in addition to the wait state needs of a slave. For example, arbitration logic in a multimaster system can force a master to wait until it is granted access to a slave.

SOPC Builder generates wait state insertion logic based on the properties of all slaves in the system.

## Pipelined Read Transfers

The Avalon-MM interface supports pipelined read transfers, allowing a pipelined master to start multiple read transfers in succession without waiting for the prior transfers to complete. Pipelined transfers allow master-slave pairs to achieve higher throughput, even though the slave requires one or more cycles of latency to return data for each transfer.

SOPC Builder generates system interconnect fabric with pipeline management logic to take advantage of pipelined components wherever possible, based on the pipeline properties of each master-slave pair in the system. Regardless of the pipeline latency of a target slave, SOPC Builder guarantees that read data arrives at each master in the order requested. Because master and slaves often have mismatched pipeline latency, system interconnect fabric often contains logic to reconcile the differences. Many cases of pipeline latency are possible, as shown in [Table 2-1](#).

**Table 2-1. Various Cases of Pipeline Latency in a Master-Slave Pair**

Master	Slave	Pipeline Management Logic Structure
No pipeline	No pipeline	The system interconnect fabric does not instantiate logic to handle pipeline latency.
No pipeline	Pipelined with fixed or variable latency	The system interconnect fabric forces the master to wait through any slave-side latency cycles. This master-slave pair gains no benefits of pipelining, because the master waits for each transfer to complete before beginning a new transfer. However, while the master is waiting, the slave can accept transfers from a different master.
Pipelined	No pipeline	The system interconnect fabric carries out the transfer as if neither master nor slave were pipelined, causing the master to wait until the slave returns data.
Pipelined	Pipelined with fixed latency	The system interconnect fabric allows the master to capture data at the exact clock cycle when data from the slave is valid. This process enables the master-slave pair to achieve maximum throughput performance.
Pipelined	Pipelined with variable latency	This is the simplest pipelined case, in which the slave asserts a signal when its <code>readdata</code> is valid, and the master captures the data. This case enables this master-slave pair to achieve maximum throughput.

SOPC Builder generates logic to handle pipeline latency based on the properties of the master and slaves in the system. When configuring a system in SOPC Builder, there are no settings that directly control the pipeline management logic in the system interconnect fabric.

## Dynamic Bus Sizing and Native Address Alignment

SOPC Builder generates system interconnect fabric to accommodate master and slaves with unmatched data widths. Address alignment affects how slave data is aligned in a master's address space, in the case that the master and slave data widths are different. Address alignment is a property of each slave, and can be different for each slave in a system. A slave can declare itself to use one of the following:

- Dynamic bus sizing

- Native address alignment

The following sections explain the implications of the address alignment property slave devices.

## Dynamic Bus Sizing

Dynamic bus sizing hides the details of interfacing a narrow component device to a wider master, and vice versa. When an  $\langle N \rangle$ -bit master accesses a slave with dynamic bus sizing, the master operates exclusively on full  $\langle N \rangle$ -bit words of data, without awareness of the slave data width.



When using dynamic bus sizing, the slave data width in units of bytes must be a power of two.

Dynamic bus sizing provides the following benefits:

- Eliminates the need to create address-alignment hardware manually.
- Reduces design complexity of the master component.
- Enables any master to access any memory device, regardless of the data width.

In the case of dynamic bus sizing, the system interconnect fabric includes a small finite state machine that reconciles the difference between master and slave data widths. The behavior is different depending on whether the master data width is wider or narrower than the slave.

### Wider Master

In the case of a wider master, the dynamic bus-sizing logic accepts a single, wide transfer on the master side, and then performs multiple narrow transfers on the slave side. For a data-width ratio of  $\langle N \rangle:1$ , the dynamic bus-sizing logic generates up to  $\langle N \rangle$  slave transfers for each master transfer. The master waits while multiple slave-side transfers complete; the master transfer ends when all slave-side transfers end.

Dynamic bus-sizing logic uses the master-side byte-enable signals to generate appropriate slave transfers. The dynamic bus-sizing logic performs as many slave-side transfers as necessary to write or read the specified byte lanes.

### Narrower Master

In the case of a narrower master, one transfer on the master side generates one transfer on the slave side. In this case, multiple master word addresses map to a single offset in the slave memory space. The dynamic bus-sizing logic maps each master address to a subset of byte lanes in the appropriate slave offset. All bytes of the slave memory are accessible in the master address space.

Table 2–2 demonstrates the case of a 32-bit master accessing a 64-bit slave with dynamic bus sizing. In the table, offset refers to the offset into the slave memory space.

**Table 2–2. 32-Bit Master View of 64-Bit Slave with Dynamic Bus Sizing**

32-bit Address	Data
0x00000000 (word 0)	OFFSET [0] <sub>31..0</sub>
0x00000004 (word 1)	OFFSET [0] <sub>63..32</sub>
0x00000008 (word 2)	OFFSET [1] <sub>31..0</sub>
0x0000000C (word 3)	OFFSET [1] <sub>63..32</sub>

In the case of a read transfer, the dynamic bus-sizing logic multiplexes the appropriate byte lanes of the slave data to the narrow master. In the case of a write transfer, the dynamic bus-sizing logic uses slave-side byte-enable signals to write only to the appropriate byte lanes.



Altera recommends that you select dynamic bus sizing whenever possible. Dynamic bus sizing offers more flexibility when the master and slave components in your system have different widths.

## Native Address Alignment

Table 2–3 demonstrates native address alignment and dynamic bus sizing for a 32-bit master connected to a 16-bit slave (a 2:1 ratio). In this example, the slave is mapped to base address *<BASE>* in the master's address space. In Table 2–3, OFFSET refers to the offset into the 16-bit slave address space.

**Table 2–3. 32-Bit Master View of 16-Bit Slave Data**

32-bit Master Address	Data with Native Alignment	Data with Dynamic Bus Sizing
<i>BASE</i> + 0x0 (word 0)	0x0000:OFFSET [0]	OFFSET [1] : OFFSET [0]
<i>BASE</i> + 0x4 (word 1)	0x0000:OFFSET [1]	OFFSET [3] : OFFSET [2]
<i>BASE</i> + 0x8 (word 2)	0x0000:OFFSET [2]	OFFSET [5] : OFFSET [4]
<i>BASE</i> + 0xC (word 3)	0x0000:OFFSET [3]	OFFSET [7] : OFFSET [6]
...	...	...
<i>BASE</i> + 4 <i>N</i> (word <i>N</i> )	0x0000:OFFSET [ <i>N</i> ]	OFFSET [2 <i>N</i> +1] : OFFSET [2 <i>N</i> ]

When connecting a wide master to a narrow slave port that uses native addressing, the following addressing formula should be used to determine what address to present to the system interconnect fabric:

$$\langle \text{master address} \rangle = \langle \text{slave base address} \rangle + (\langle \text{slave word offset} \rangle * \langle \text{master data width in bytes} \rangle)$$

For example, a 64-bit master needs to write to the second word of a 32-bit slave that uses native addressing the formula would reduce to:

$$\langle \text{master address} \rangle = \langle \text{slave base address} \rangle + (1 * 8)$$



SOPC Builder generates appropriate address-alignment logic based on the properties of the master and slaves in the system. When configuring a system in SOPC Builder, there are no settings that directly control the address alignment in the system interconnect fabric.

## Arbitration for Multimaster Systems

System interconnect fabric supports systems with multiple master components. In a system with multiple masters, such as the system pictured in [Figure 2-1 on page 2-2](#), the system interconnect fabric provides shared access to slaves using a technique called slave-side arbitration. Slave-side arbitration moves the arbitration logic close to the slave, such that the algorithm that determines which master gains access to a specific slave in the event that multiple masters attempt to access the same slave at the same time.

The multimaster architecture used by system interconnect fabric offers the following benefits:

- Eliminates having to create arbitration hardware manually.
- Allows multiple masters to transfer data simultaneously. Unlike traditional host-side arbitration architectures where each master must wait until it is granted access to the shared bus, multiple Avalon-MM masters can simultaneously perform transfers with independent slaves. Arbitration logic stalls a master only when multiple masters attempt to access the same slave during the same cycle.
- Eliminates unnecessary master-slave connections. The connection between a master and a slave exists only if it is specified in SOPC Builder. If a master never initiates transfers to a specific slave, no connection is necessary, and therefore SOPC Builder does not waste logic resources to connect the two ports.
- Provides configurable arbitration settings, and arbitration for each slave is specified independently. For example, you can grant one master more arbitration shares than others, allowing it to gain more access cycles to the slave. The arbitration share settings are defined for each slave independently.
- Simplifies master component design. The details of arbitration are encapsulated inside the system interconnect fabric. Each Avalon-MM master connects to the system interconnect fabric as if it is the only master in the system. As a result, you can reuse a component in single-master and multimaster systems without requiring design changes to the component.

## Traditional Shared Bus Architectures

This section discusses the architecture of the system interconnect fabric generated by SOPC Builder for multimaster systems. As a frame of reference for the discussion of multiple masters and arbitration, this section describes traditional bus architectures.

In traditional bus architectures, one or more bus masters and bus slaves connect to a shared bus, consisting of wires on a printed circuit board or on-chip routing. A single arbiter controls the bus (that is, the path between bus masters and bus slaves), so that multiple bus masters do not simultaneously drive the bus. Each bus master requests control of the bus from the arbiter, and the arbiter grants access to a single master at a time. Once a master has control of the bus, the master performs transfers with any bus slave. When multiple masters attempt to access the bus at the same time, the arbiter allocates the bus resources to a single master, forcing all other masters to wait.

Figure 2-6 illustrates the bus architecture for a traditional processor system. Access to the shared system bus becomes the bottleneck for throughput: only one master has access to the bus at a time, which means that other masters are forced to wait and only one slave can transfer data at a time.

**Figure 2-6. Bus Architecture in a Traditional Microprocessor System**

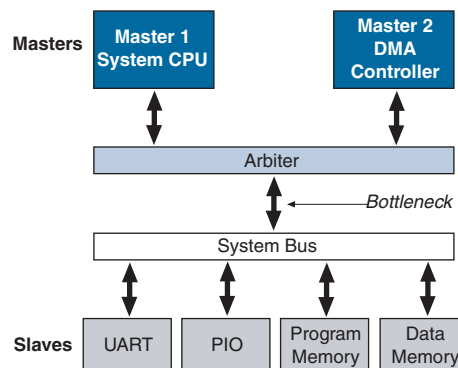

## Slave-Side Arbitration

The system interconnect fabric uses multimaster architecture to eliminate the bottleneck for access to a shared bus. Multiple masters can be active at the same time, simultaneously transferring data with independent slaves. For example, [Figure 2-1 on page 2-2](#) demonstrates a system with two masters (a CPU and a DMA controller) sharing a slave (an SDRAM controller). Arbitration is performed at the SDRAM slave; the arbiter dictates which master gains access to the slave if both masters initiate a transfer with the slave in the same cycle.

Figure 2-7 focuses on the two masters and the shared slave and shows additional detail of the data, address, and control paths. The arbiter logic multiplexes all address, data, and control signals from a master to a shared slave.

**Figure 2-7. Detailed View of Multimaster Connections**

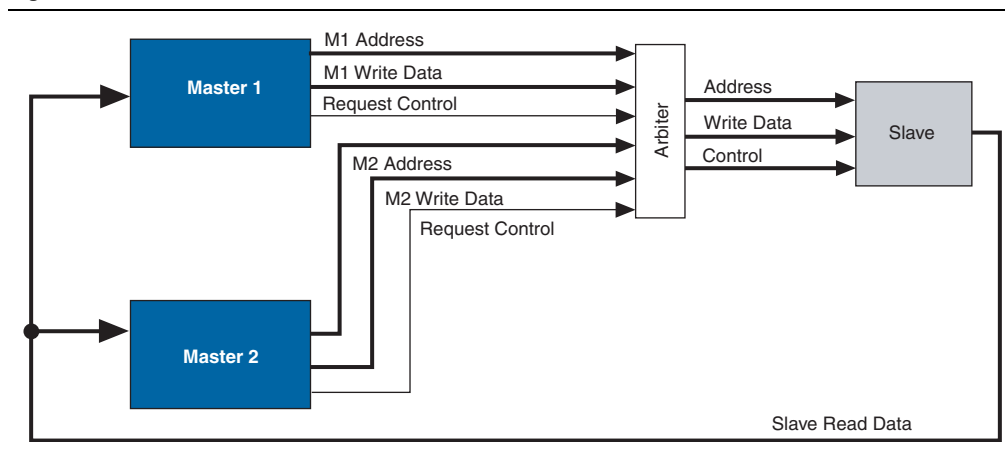

## Arbiter Details

SOPC Builder generates an arbiter for every slave, based on arbitration parameters specified in SOPC Builder. The arbiter logic performs the following functions for its slave:

- Evaluates the address and control signals from each master and determines which master, if any, gains access to the slave next.
- Grants access to the chosen master and forces all other requesting masters to wait.
- Uses multiplexers to connect address, control, and datapaths between the multiple masters and the slave.

Figure 2-8 shows the arbiter logic in an example multimaster system with two masters, each connected to two slaves.

Figure 2-8. Block Diagram of Arbiter Logic

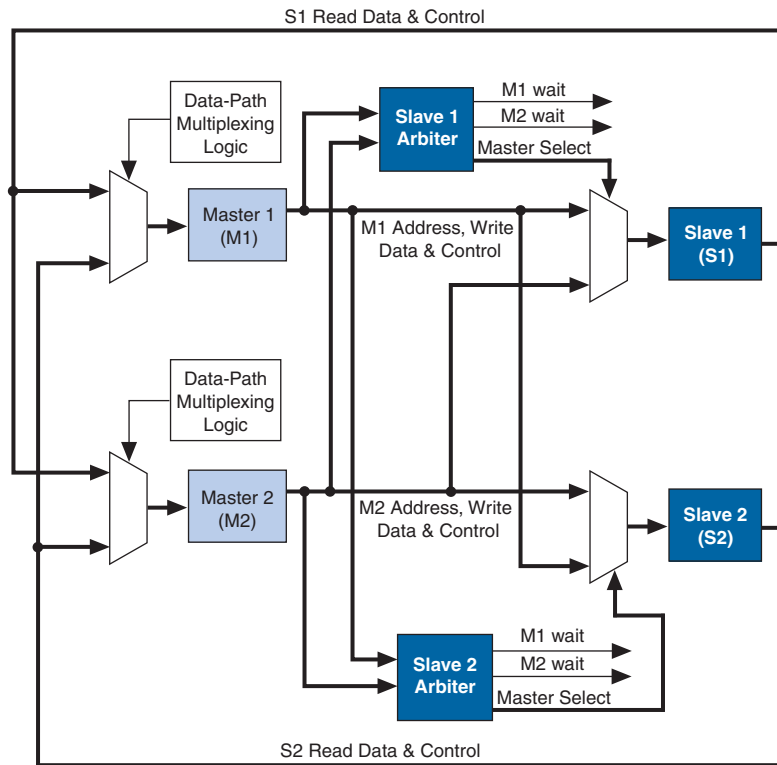

## Arbitration Rules

This section describes the rules by which the arbiter grants access to masters when they contend.

### Setting Arbitration Parameters in SOPC Builder

You specify the arbitration shares for each master using the connection panel on the System Contents tab of SOPC Builder, as shown in Figure 2-9.

Figure 2-9. Arbitration Settings on the System Contents Tab

Module Name	Description	Clock
<input type="checkbox"/> cpu	Nios II Processor - Alte...	clk
<input type="checkbox"/> instruction_master	Master port	
<input type="checkbox"/> data_master	Master port	
1 <input type="checkbox"/> jtag_debug_module	Slave port	
1 <input checked="" type="checkbox"/> sys_clk_timer	Interval timer	clk
1 <input checked="" type="checkbox"/> ext_ram_bus	Avalon Tri-State Bridge	clk
<input type="checkbox"/> ext_flash	Flash Memory (Commo...	
<input type="checkbox"/> ext_ram	IDT71V416 SRAM	
1 <input checked="" type="checkbox"/> epcs_controller	EPCS Serial Flash Cont...	clk
<input type="checkbox"/> lan91c111	LAN91c111 Interface (...)	
1 <input checked="" type="checkbox"/> jtag_uart	JTAG UART	clk

The arbitration settings are hidden by default. To see them, on the View menu, click **Show Arbitration**.

## Fairness-Based Shares

Arbiter logic uses a fairness-based arbitration scheme. In a fairness-based arbitration scheme, each master pair has an integer value of transfer *shares* with respect to a slave. One share represents permission to perform one transfer.

For example, assume that two masters continuously attempt to perform back-to-back transfers to a slave. Master 1 is assigned three shares and Master 2 is assigned four shares. In this case, the arbiter grants Master 1 access for three transfers, then Master 2 for four transfers. This cycle repeats indefinitely. Figure 2-10 demonstrates this case, showing each master's transfer request output, wait request input (which is driven by the arbiter logic), and the current master with control of the slave.

**Figure 2-10. Arbitration of Continuous Transfer Requests from Two Masters**

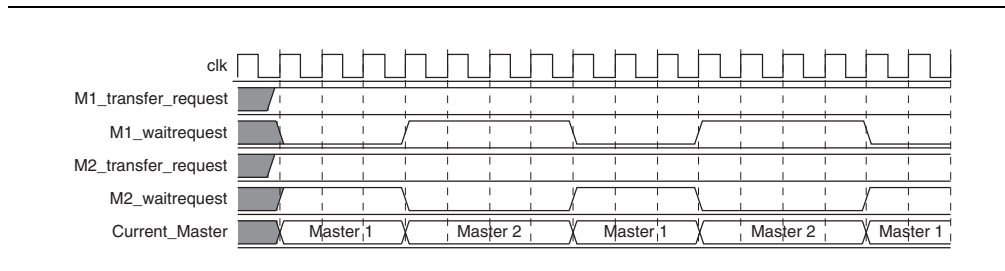

If a master stops requesting transfers before it exhausts its shares, it forfeits all its remaining shares, and the arbiter grants access to another requesting master. Refer to Figure 2-11. After completing one transfer, Master 2 stops requesting for one clock cycle. As a result, the arbiter grants access back to Master 1, which gets a replenished supply of shares.

**Figure 2-11. Arbitration of Two Masters with a Gap in Transfer Requests**

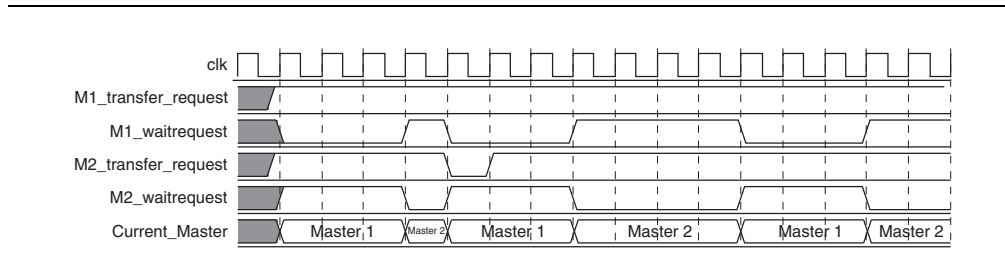

## Round-Robin Scheduling

When multiple masters contend for access to a slave, the arbiter grants shares in round-robin order. Round-robin scheduling drives a request interface according to space available and data available credit interfaces. At every slave transfer, only requesting masters are included in the arbitration.

## Burst Transfers

Avalon-MM burst transfers grant a master uninterrupted access to a slave for a specified number of transfers. The master specifies the number of transfers when it initiates the burst. Once a burst begins between a master-slave pair, arbiter logic does not allow any other master to access the slave until the burst completes. For burst masters, the size of the burst determines the number of cycles that the master has access to the slave, and the selected arbitration shares have no effect.

## Burst Adapters

System interconnect fabric provides burst adaptation logic to accommodate the burst capabilities of each port in the system, including ports that do not support burst transfers. Burst adaptation logic consists of a finite state machine that translates the sequencing of address and control signals between the slave side and the master side.

The maximum burst length for each port is determined by the component design and is independent of other ports in the system. Therefore, a particular master might be capable of initiating a burst longer than a slave's maximum supported burst length. In this case, the burst management logic translates the master burst into smaller slave bursts, or into individual slave transfers if the slave does not support bursts. Until the master completes the burst, the arbiter logic prevents other masters from accessing the target slave.

For example, if a master initiates a burst of 16 transfers to a slave with maximum burst length of 8, the burst adapter logic initiates two bursts of length 8 to the slave. If the master initiates a burst of 14, the burst adapter logic segments the burst transfer into a burst of 8 words followed by a burst of 6 words, because the slave can only handle a maximum burst length of 8. If a master initiates a burst of 16 transfers to a slave that does not support bursts, the burst management logic initiates 16 separate transfers to the slave.



The burst adapter inserts one idle cycle at the start of each burst. System throughput is maximized when burst sizes are as large as possible.

In the case of a non-linewrap burst master connected to a slave with the `linewrapBursts` property set to `TRUE`, it is not always possible to issue the maximum-sized burst to the slave. In these cases the burst adapter is not capable of adapting the master and slave pairing. An adapter is generated; however, if the master performs a burst transaction to the slave that crosses the slave burst boundary data corruption can occur. To avoid a functional failure, you should ensure the master posts bursts of length one until the master burst boundary has been reached. The master burst boundary has an alignment of `<master_data_width> × <master_maximum_burst_length>`.

Any burst transaction that begins on a master burst boundary is guaranteed to not cross the burst boundary of the slave port regardless of the slave port's maximum burst length. Typically the only Avalon-MM interfaces that support burst wrapping are burst capable SDRAM controllers.



For more information about the `linewrapBursts` property, refer to the *Avalon Memory-Mapped Slave Interfaces* chapter in the *Avalon Interface Specifications*.

## Interrupts

In systems where components have interrupt request (IRQ) sender interfaces, the system interconnect fabric includes interrupt controller logic. A separate interrupt controller is generated for each interrupt receiver. The interrupt controller aggregates IRQ signals from all interrupt senders, and maps them to user-specified values on the receiver inputs.

 For further information, refer to the *Interrupt Interfaces* chapter in the *Avalon Interface Specifications*.

### Individual Requests IRQ Scheme

In the individual requests IRQ scheme, the system interconnect fabric passes IRQs directly from the sender to the receiver, without making any assumptions about IRQ priority. In the event that multiple senders assert their IRQs simultaneously, the receiver logic (presumably under software control) determines which IRQ has highest priority, then responds appropriately.

Using individual requests, the interrupt controller can handle up to 32 IRQ inputs. The interrupt controller generates a 32-bit signal `irq[31:0]` to the receiver, and simply maps slave IRQ signals to the bits of `irq[31:0]`. Any unassigned bits of `irq[31:0]` are disabled. [Figure 2-12](#) shows an example of the interrupt controller mapping the IRQs on four senders to `irq[31:0]` on a receiver.

**Figure 2-12. IRQ Mapping Using Software Priority**

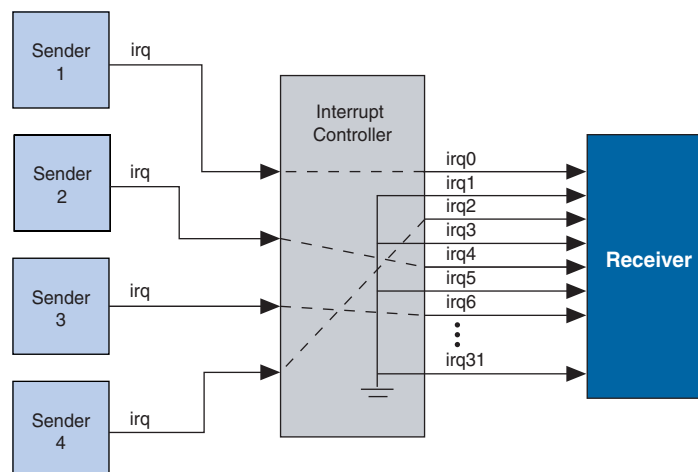

### Priority Encoded Interrupt Scheme

In the priority encoded interrupt scheme, in the event that multiple slaves assert their IRQs simultaneously, the system interconnect fabric provides the interrupt receiver with a 1-bit interrupt signal, and the number of the highest priority active interrupt. An IRQ of lesser priority is undetectable until all IRQs of higher priority have been serviced.

Using priority encoded interrupts, the interrupt controller can handle up to 64 slave IRQ signals. The interrupt controller generates a 1-bit `irq` signal to the receiver, signifying that one or more senders have generated an IRQ. The controller also generates a 6-bit `irqnumber` signal, which outputs the encoded value of the highest pending IRQ. See Figure 2-13.

**Figure 2-13. IRQ Mapping Using Hardware Priority**

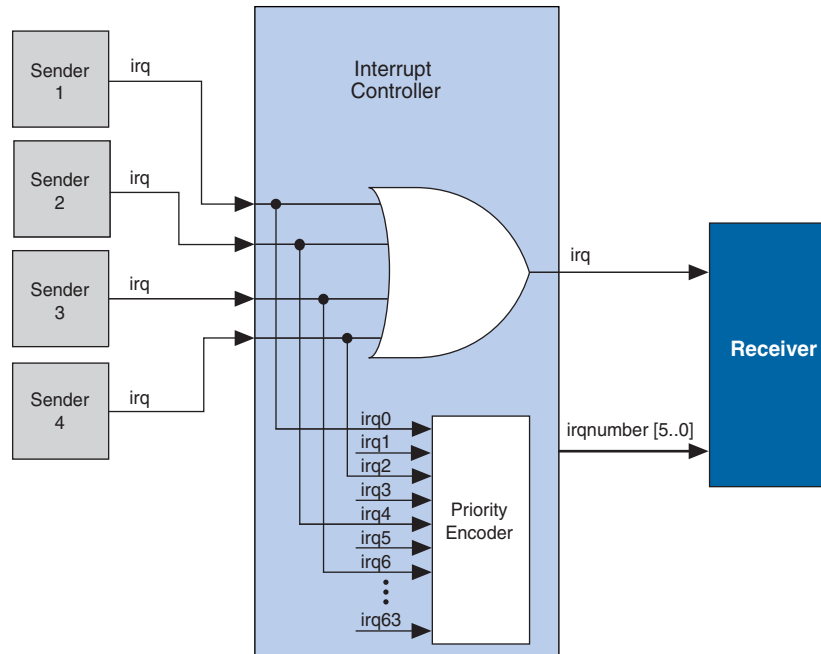

## Assigning IRQs in SOPC Builder

You specify IRQ settings on the **System Contents** tab of SOPC Builder. After adding all components to the system, you make IRQ settings for all interrupt senders, with respect to each interrupt receiver. For each slave, you can either specify an IRQ number, or specify not to connect the IRQ.

## Reset Distribution

SOPC Builder generates the logic used in the system interconnect fabric, which drives the reset pulse to all the logic. The system interconnect fabric distributes the reset signal conditioned for each clock domain. The duration of the reset signal is at least one clock period.

The system interconnect fabric asserts the system-wide reset in the following conditions:

- The global reset input to the SOPC Builder system is asserted.
- Any component asserts its `resetrequest` signal.

The global reset and reset requests are ORed together. This signal is then synchronized to each clock domain associated to an Avalon-MM port, which causes the asynchronous resets to be de-asserted synchronously.



The interconnect fabric for Avalon<sup>®</sup> Streaming connects high-bandwidth, low latency components that use the Avalon Streaming (Avalon-ST) interface. This interconnect fabric creates datapaths for unidirectional traffic including multichannel streams, packets, and DSP data. This chapter describes the Avalon-ST interconnect fabric and its use in connecting components with Avalon-ST interfaces. Descriptions of specific adapters and their use in streaming systems can be found in the following sections:

- “Adapters” on page 3-3
- “Multiplexer Examples” on page 3-5

## High-Level Description

Avalon-ST interconnect fabric is logic generated by SOPC Builder. Using SOPC Builder, you specify how Avalon-ST source and sink ports connect. SOPC Builder then creates a high performance point-to-point interconnect between the two components. The Avalon-ST interconnect is flexible and can be used to implement on-chip interfaces for industry standard telecommunications and data communications cores, such as Ethernet IEEE 802.3 MAC and SPI 4.2. In all cases, bus widths, packets, and error conditions are custom-defined.

Figure 3-1 illustrates the simplest system example that generates an interconnect between the source and sink. This source-sink pair includes only the data and valid signals.

**Figure 3-1. Interconnect for a Simple Avalon Streaming Source-Sink Pair**

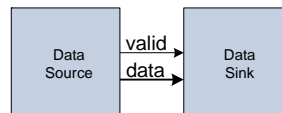
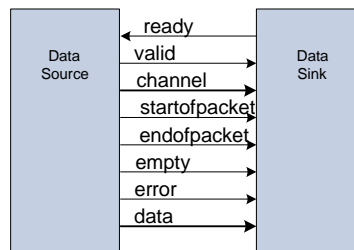



Figure 3-2 illustrates a more extensive interface that includes signals indicating the start and end of packets, channel numbers, error conditions, and back pressure.

**Figure 3-2. Avalon Streaming Interface for Packet Data**



All data transfers using Avalon-ST interconnect occur synchronously to the rising edge of the associated clock interface. All outputs from the source interface, including the data, channel, and error signals, must be registered on the rising edge of the clock. Registers are not required for inputs at the sink interface. Registering signals only at the source provides for high frequency operation while eliminating back-to-back registration with no intervening logic. There is no inherent maximum performance of the interconnect. Throughput for a system depends on the components and how they are connected.

 For details about the Avalon-ST interface protocol, refer to the [Avalon Interface Specifications](#).

## Avalon Streaming and Avalon Memory-Mapped Interfaces

The Avalon-ST and Avalon Memory-Mapped (Avalon-MM) interfaces are complementary. High bandwidth components with streaming data typically use Avalon-ST interfaces for the high throughput datapath. These components can also use Avalon-MM connection interfaces to provide an access point for control. In contrast to the Avalon-MM interconnect, which can be used to create a wide variety of topologies, the Avalon-ST interconnect fabric always creates a point-to-point between a single data source and data sink, as [Figure 3-3](#) illustrates. There are two connection pairs in this figure:

- The data source in the Rx Interface transfers data to the data sink in the FIFO.
- The data source in the FIFO transfers data to the Tx Interface data sink.

In Figure 3-3, the Avalon-MM interface allows a processor to access the data source, FIFO or data sink to provide system control.

**Figure 3-3. Use of the Avalon Memory-Mapped and Streaming Interfaces**

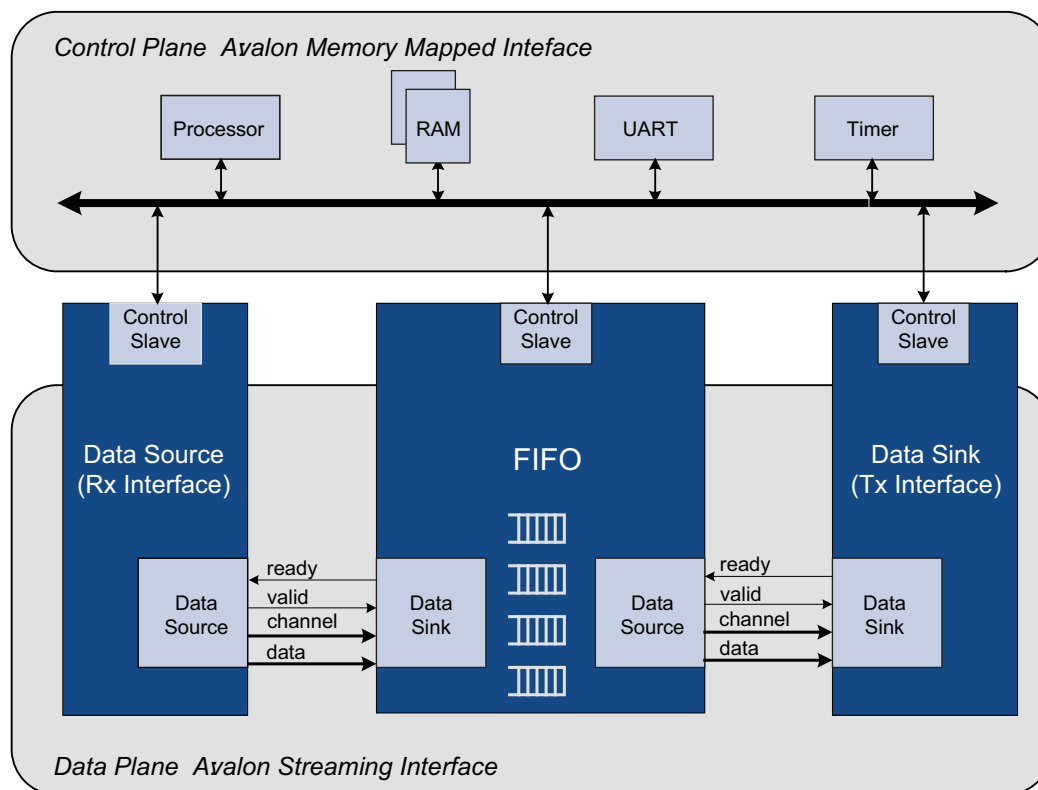

## Adapters

Adapters are configurable SOPC Builder components that are part of the streaming interconnect fabric. They are used to connect source and sink interfaces that are not exactly the same without affecting the semantics of the data. SOPC Builder includes the following four adapters:

- Data Format Adapter
- Timing Adapter
- Channel Adapter
- Error Adapter

You can add Avalon-ST adapters between two components with mismatched interfaces. The adapter allows you to connect a data source to a data sink of differing byte sizes. If you connect mismatched Avalon-ST sources and sinks in SOPC Builder without inserting adapters, SOPC Builder generates error messages. Inserting adapters into the system does not change the types of components that SOPC Builder allows you to connect. The **Insert Avalon-ST Adapters** command on the System menu attempts to correct these errors automatically, if possible, by inserting the appropriate adapter types.

 For complete information about these adapters, refer to [Chapter 12, Avalon Streaming Interconnect Components](#).

The following sections provide an overview of these adapters.

## Data Format Adapter

The data format adapter allows you to connect interfaces that have different values for the parameters defining the data signal. One of the most common uses of this adapter is to convert data streams of different widths. [Figure 3-4](#) shows an adapter that allows a connection between a 128-bit input data stream and three 32-bit output data streams.

**Figure 3-4. Avalon Streaming Interconnect Fabric with Data Format Adapter**

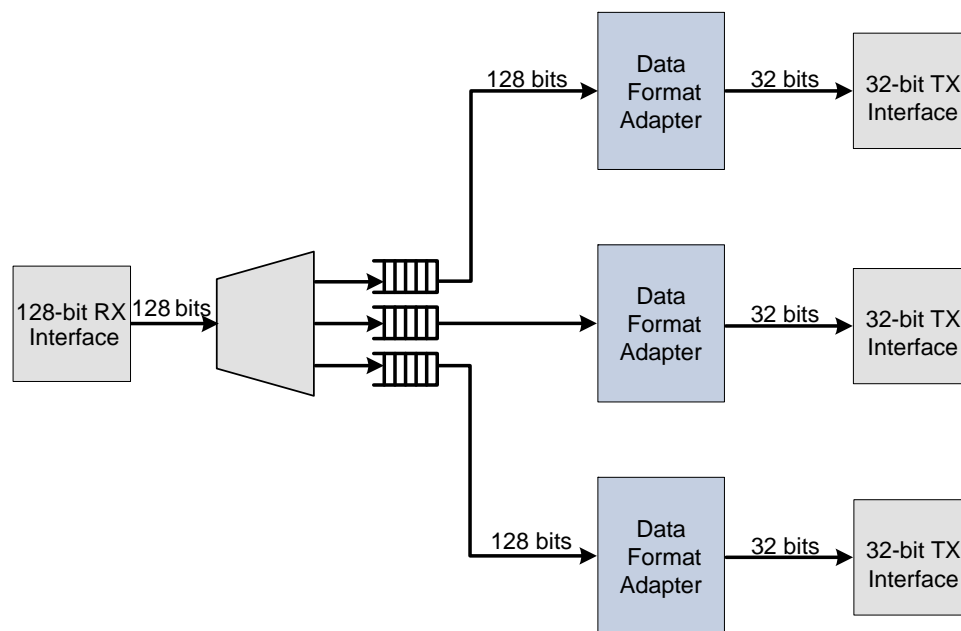

## Timing Adapter

The timing adapter allows you to connect component interfaces that require a different number of cycles before driving or receiving data. This adapter inserts a FIFO between the source and sink to buffer data or pipeline stages to delay the back pressure signals. The timing adapter can also be used to connect interfaces that support the ready signal and those that do not.

## Channel Adapter

The channel adapter provides adaptations between interfaces that have different support for the channel signal or channel-related parameters. For example, if the source channel is narrower than the sink channel, you can use this adapter to connect them. The high-order bits of the sink channel are connected to zero. You can also use this adapter to connect a source with a wider channel to a sink with a narrower channel. If the source provides data for a channel that the sink cannot receive, the data is not transferred.

## Error Adapter

The error adapter ensures that per-bit error information provided by the source interface is correctly connected to the sink interface's input error signal. Matching error conditions handled by the source and sink are connected. If the source has an error condition that is not supported by the sink, the signal is left unconnected; the adapter provides a simulation error message and an error indication if this error is ever asserted. If the sink has an error condition that is not supported by the source, the sink's input is tied to zero.

## Multiplexer Examples

You can combine these adapters with streaming components to create datapaths whose input and output streams have different properties. The following sections provide examples of datapaths constructed using SOPC Builder in which the output stream is higher performance than the input stream:

- The first example shows an output with double the throughput of each interface with a corresponding doubling of the clock frequency.
- The second example doubles the data width.
- The third example boosts the frequency of a stream by 10% by multiplexing input data from two sources.

## Example to Double Clock Frequency

Figure 3-5 illustrates a datapath that uses the dual clock version of the on-chip FIFO memory and Avalon-ST channel multiplexer to merge the 100 MHz input from two streaming data sources into a single 200 MHz streaming output. As Figure 3-5 illustrates, this example increases throughput by increasing the frequency and combining inputs.

Figure 3-5. Datapath that Doubles the Clock Frequency

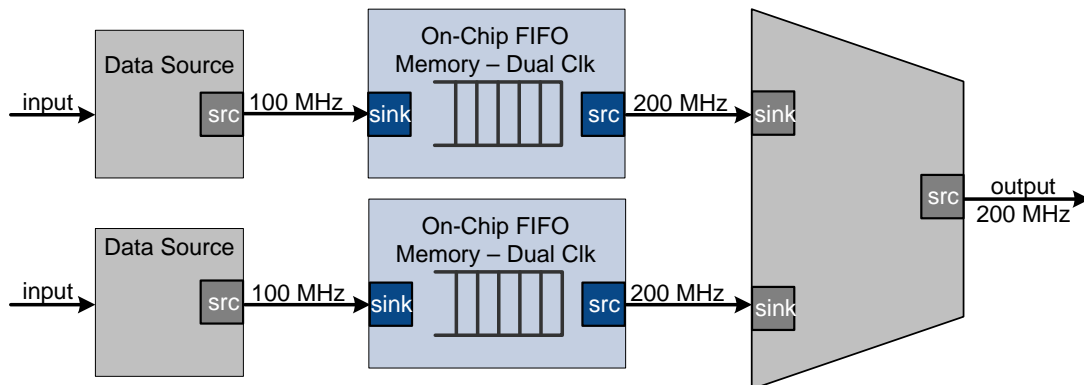

## Example to Double Data Width and Maintain Frequency

Figure 3-6 illustrates a datapath that uses the data format adapter and Avalon-ST channel multiplexer to convert two, 8-bit inputs running at 100 MHz to a single 16-bit output at 100 MHz.

Figure 3-6. Datapath to Double Data Width and Maintain Original Frequency

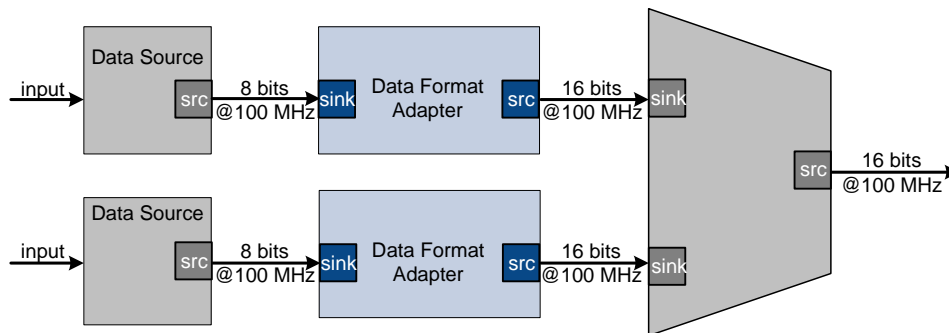

## Example to Boost the Frequency

Figure 3-7 illustrates a datapath that uses the dual clock version of the on-chip FIFO memory to boost the frequency of input data from 100 MHz to 110 MHz by sampling two input streams at differential rates. In this example, the on-chip FIFO memory has an input clock frequency of 100 MHz and an output clock frequency of 110 MHz. The channel multiplexer runs at 110 MHz and samples one input stream 27.3 percent of the time and the second 72.7 percent of the time.

You do not need to know what the typical and maximum input channel utilizations are before attempting this. For example, if the first channel hits 50% utilization, the output stream exceeds 100% utilization.

**Figure 3-7. Datapath to Boost the Clock Frequency**

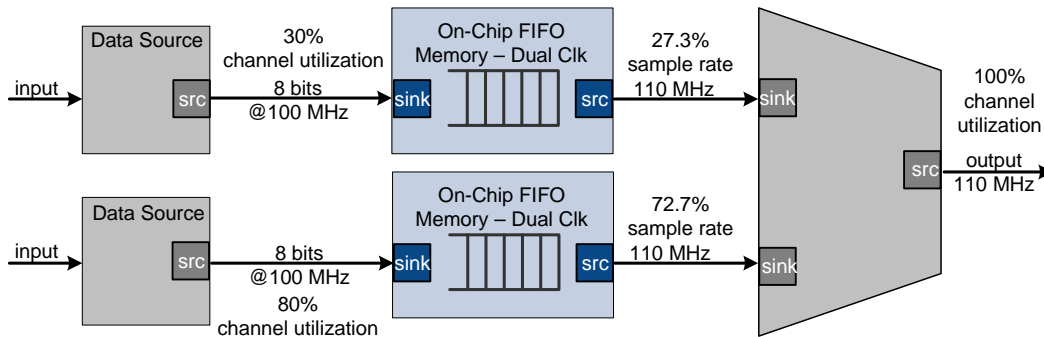





An SOPC Builder *component* is a hardware design block available within SOPC Builder that can be instantiated in an SOPC Builder system. This chapter defines SOPC Builder components, with emphasis on the structure of custom components.

A component includes the following:

- The HDL description of the component's hardware.
- A description of the interface to the component hardware, such as the names and types of I/O signals.
- A description of the parameters that determine the operation of the component.
- A GUI for parameterizing an instance of the component in SOPC Builder.
- Scripts and other information SOPC Builder requires to generate the HDL files for the component and integrate the component instance into the SOPC Builder system.
- Other component-related information, such as reference to software drivers, necessary for development steps downstream of SOPC Builder.

This chapter discusses the design flow for new and classic custom-defined SOPC Builder components, in the following sections:

- [“Component Providers”](#)
- [“Component Hardware Structure” on page 4-2](#)
- [“Exported Connection Points—Conduit Interfaces” on page 4-3](#)
- [“SOPC Builder Component Search Path” on page 4-4](#)
- [“Component Structure” on page 4-8](#)
- [“Classic Components in SOPC Builder” on page 4-10](#)

### Component Providers

SOPC Builder components can be obtained from many providers, including the following:

- The components automatically installed with the Quartus® II software.
- Third-party IP developers can provide IP blocks as SOPC Builder-ready components, including software drivers and documentation. A list of third-party components can be found in SOPC Builder by clicking **IP MegaStore** on the Tools menu.
- Altera development kits, such as the Nios® II Development Kit, can provide SOPC Builder components as features.
- You can use the SOPC Builder component editor to convert your own HDL files into custom components.

 For more information about the `_hw.tcl` file, refer to [Chapter 6, Component Editor](#).

## Component Hardware Structure

There are the following types of components in an SOPC Builder system, based on where the associated component logic resides:

- Components that include their associated logic inside the SOPC Builder system
- Components that interface to logic outside the SOPC Builder system

Figure 4–1 shows an example of both types of components.

**Figure 4–1. Component Logic Inside and Outside the SOPC Builder System**

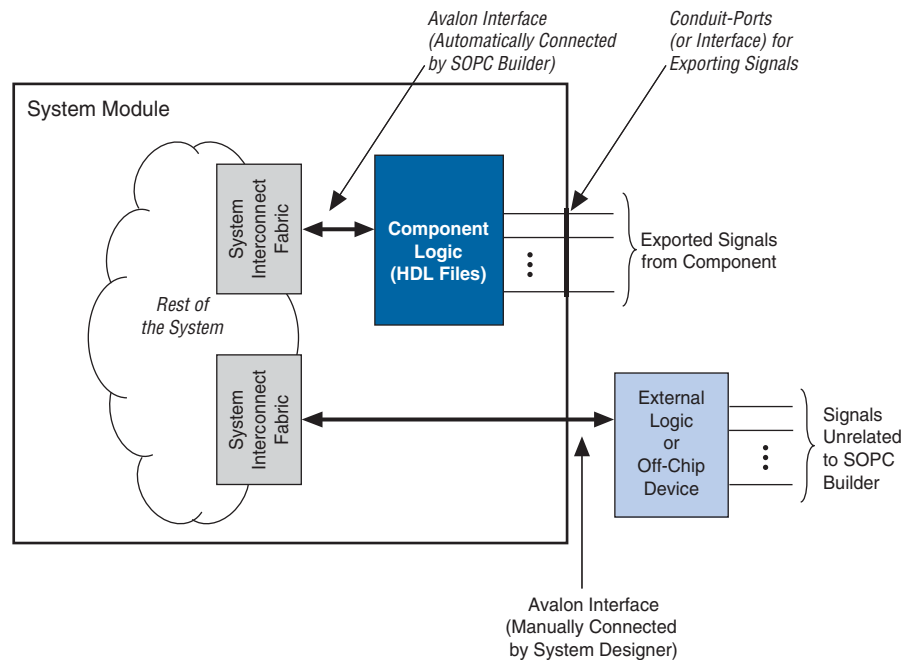

## Component Instances Inside the SOPC Builder System

For components that are instantiated inside the SOPC Builder system, the component defines its logic in an associated HDL file. During system generation, SOPC Builder instantiates the component and connects it to the rest of the system. The component can include exported signals in conduit interfaces. Conduit interfaces become ports on the system, so they can be connected to logic outside the SOPC Builder system in the board-level schematic.

 For more information about conduit interfaces, refer to the *Conduit Interfaces* chapter in the *Avalon Interface Specifications*.

In general, components connect to the system interconnect fabric using the Avalon<sup>®</sup> Memory-Mapped (Avalon-MM) interface or the Avalon Streaming (Avalon-ST) interface. A single component can provide more than one Avalon port. For example, a component might provide an Avalon-ST source port for high-throughput data, in addition to an Avalon-MM slave for control.

## Static HDL Components

You can define SOPC Builder components that accept Verilog HDL parameters or VHDL generics. Examples of parameters that can be expressed as Verilog HDL parameters or VHDL generics are address and data widths and FIFO depths. These components have HDL files that are not generated as a function of the parameterization, and are referred to as static HDL components. SOPC Builder automatically generates the top-level HDL wrapper file to apply parameter values for static components.

## Generated HDL Components

Alternatively, you can also define a component whose HDL is generated based on the value of its declared parameters. These components use a custom generation callback to generate the HDL for each use of the component, instead of having SOPC Builder create an HDL wrapper that specifies these values. An example of a parameter that requires generated HDL is a parameter that controls the number of interfaces.

## Composed HDL Components

Composed components are constructed from combinations of other components. You can use a compose callback to connect and parameterize a composed component; however, a custom compose callback may not be necessary for very simple composed components.

 For more information about defining your own generation or compose callback procedure, refer to the *Generation Callback* and *Compose Callback* sections in [Chapter 7, Component Interface Tcl Reference](#).

## Components Outside the SOPC Builder System

For components that interface to external logic or off-chip devices with Avalon-compatible signals outside the SOPC Builder system, the component files describe only the interface to the external logic. During system generation, SOPC Builder exports an interface for the component in the top-level SOPC Builder system. You must manually connect the signals at the top-level of SOPC Builder to pins or logic defined outside the system that already has Avalon-compatible signals.

 This type of component is deprecated and will not be available in future versions of the Quartus II software.

## Exported Connection Points—Conduit Interfaces

Conduit interfaces are brought to the top level of the system as additional ports. Exported signals are usually either application-specific signals or the Avalon interface signals.

Application-specific signals are exported to the top level of the system by the conduit interface(s) defined in the `_hw.tcl` file. These are I/O signals in a component's HDL logic that are not part of any Avalon interfaces and connect to an external device, for example DDR SDRAM memory, or logic defined outside of the SOPC Builder system. You use conduit interfaces to connect application-specific signals of the external device and the SOPC Builder system.

You can also export the Avalon interfaces to manually connect them to external devices or logic defined outside a system with Avalon-compatible signals. This method allows a direct connection to the Avalon interface from any device that has Avalon-compatible signals. You can also export the Avalon interface in either an HDL file using conduit interfaces, or in the `_hw.tcl` file without an HDL file.

You export the Avalon interface signals as an HDL file with simple wire connections in the HDL description. The Avalon interface port signals are directly connected to external I/O signals in the HDL description. The conduit interface in the `_hw.tcl` file exports the external I/O signals to the top level of the system.

In the `_hw.tcl` file, no HDL files are specified and only the Avalon signals and interface ports are declared in the file.

## SOPC Builder Component Search Path

Each time SOPC Builder starts, it searches for component files. The components that SOPC Builder finds are displayed in the list of available components on the SOPC Builder **System Contents** tab. When you launch SOPC Builder the directories in the IP search path are searched for two kinds of files:

- `_hw.tcl` files. Each `_hw.tcl` file defines a single component.
- IP Index (`.ipx`) files. Each file indexes a collection of available components.

In general, `.ipx` files facilitate faster startup for SOPC Builder and other tools because fewer files need to be read and analyzed.

Some directories are searched recursively; others only to a specific depth. In the following list of search locations, a recursive descent is annotated by `**`. The `*` signifies any file. When a directory is recursively searched, the search stops at any directory containing a `_hw.tcl` or `.ipx` file; subdirectories are not searched.

- `$$PROJECT_DIR/*`
- `$$PROJECT_DIR/ip/**/*`
- `$QUARTUS_INSTALLDIR/./ip/**/*`

In SOPC Builder, you can extend the default search path by including additional directories by clicking **Options**, then clicking **IP Search Path** and **Add**. These additional paths apply to all projects; that is, the paths are global to the current version of SOPC Builder. The search path is ultimately defined by the file, `<$QUARTUS_INSTALLDIR>/sopc_builder/bin/root_components.ipx`.

## Installing Additional Components

There are a few different ways to make your components available to SOPC Builder projects. The following sections describe some of these methods.

## Copy to the IP Root Directory

The simplest strategy is to copy your components into the standard IP directory provided by Altera. Figure 4-2 illustrates this approach.

**Figure 4-2. User Library Included In Subdirectory of \$IP\_ROOTDIR**

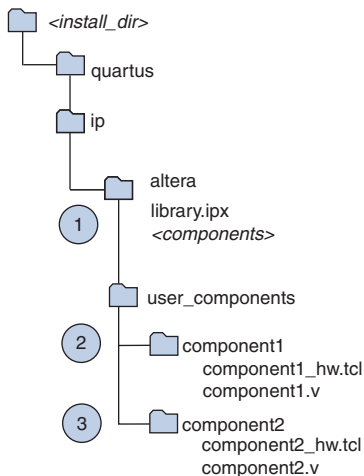

In Figure 4-2, the circled numbers identify three steps of the algorithm that SOPC follows during initialization. These steps are explained in the following paragraphs.

1. SOPC Builder recursively searches the `<install_dir>/ip/` directory by default. It finds the file in the `altera` subdirectory, which tells it about all of the Altera components. `library.ipx` includes listings for all components found in its subdirectories. The recursive search stops when SOPC Builder finds this `.ipx` file.
2. As part of its recursive search, SOPC Builder also looks in the adjacent `user_components` directory. One level down SOPC Builder finds the `component1` directory, which contains `component1_hw.tcl`. When SOPC Builder finds that component, the recursive descent stops so that no components in subdirectories of `component1` are found.
3. SOPC Builder then searches in the adjacent `component2` directory, which includes `component2_hw.tcl`. If SOPC Builder finds that component, the recursive descent stops.



If you save your `_hw.tcl` file in the `<install_dir>/ip/` directory, SOPC Builder finds your `_hw.tcl` file and stops. SOPC Builder does not conduct the search just described.

## Reference Components in an .ipx File

A second approach is to specify your IP directory in a `user_components.ipx` file under `<install_dir>/ip` path. [Figure 4-3](#) illustrates this approach.

**Figure 4-3. Specifying A User .ipx directory**

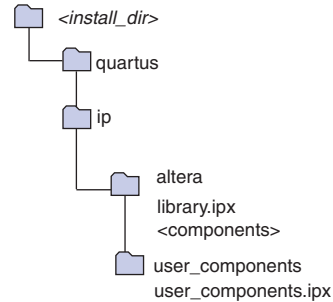

The `user_components.ipx` file includes a single line of code redirecting SOPC Builder to the location of the user library. [Example 4-1](#) shows the code for this redirection.

**Example 4-1. Redirect to User Library**

```

<library>
  <path path="c:/<user_install_dir>/user_ip/**/*" />
/<library>
  
```



For both of these approaches, if you install a new version of the Quartus II software, you must also update the installation to include your libraries.

You can verify that components are available and also decrease the time it takes to launch SOPC Builder by using two utilities, `ip-catalog` and `ip-make-ipx`. The following sections describe these utilities.

### `ip-catalog`

Shows the a catalog of components in either plain text or XML format.

#### Usage

```

ip-catalog --project-dir [= <directory>] --name [= <value>]
--verbose [= <true/false>] --xml [= <true/false>] --help
  
```

## Options

- `--project-dir [=<directory>]`. Optional. Components can be found in certain locations relative to the project, if any. By default, the current directory, `'.` is used. To exclude any project directory, use `"`.
- `--name [=<value>]`. Optional. This argument provides a pattern to filter the names of the components found. To show all components, use a `*` or `'`. By default, all components are shown. The argument is not case sensitive.
- `--verbose [=<true/false>]`. Optional. When true, reports the progress of the command.
- `--xml [=<true/false>]`. Optional. When true, prints the output in XML format instead of a line- and colon-delimited format.
- `--help`. Shows help for the `ip-catalog` command.

## ip-make-ipx

This command creates an index file for the directory specified. It returns a 0 for successful completion and a non-zero value for failure.

### Usage

```
ip-make-ipx --source-directory [=<directory>] --output [=<file>]
--relative-vars [=<value>] --thorough-descent
--message-before [=<value>] --message-after [=<value>] --help
```

### Options

- `--source-directory= <directory>`. Optional. The directory to index. The default directory is `"`. You can also provide a comma separated list of directories.
- `--output [=<file>]`. Optional. The name of the file to generate. The default name is `./components.ipx`.
- `--relative-vars [=<value>]`. Optional. Causes the output file to include references relative to the specified variable or variables where possible. You can specify multiple variables as a comma-separated list.
- `--thorough-descent [=<true/false>]`. Optional. If set, a component or `.ipx` file in a directory does not prevent subdirectories from being searched.
- `--message-before [=<value>]`. Optional. A message to print to stdout when indexing begins
- `--message-after [=<value>]`. Optional. A message to print to stdout when indexing completes
- `--help`. Show help for this command

## Understanding IPX File Syntax

An `.ipx` file is an XML file whose top-level element is `<library>` with a `<path>` subelements are `<path>` and `<component>`.

A `<path>` element contains a single attribute, also called `path` and may reference a directory with a wildcard, (\*), or reference a single file. Two asterisks designate any number of subdirectories. A single asterisk designates a match to a single file or directory. In searching down the designated path, the following three types of files are identified:

- `.ipx`—additional index files
- `_hw.tcl`—SOPC Builder component definitions
- `_sw.tcl`—Nios II board support package (BSP) software component definitions

A `<component>` element contains several attributes to define a component. If you provide all the required details for each component in an `.ipx` file, the start-up time for SOPC Builder is less than if SOPC Builder must discover the files in a directory.

[Example 4-2](#) shows two `<component>` elements. Note that the paths for file names are specified relative to the `.ipx` file.

#### Example 4-2. Component Elements

```
<library>
  <component
    name="An SOPC Component"
    displayName="SOPC Component"
    version="2.1"
    file="./components/sopc_component/sc_hw.tcl"
  />
  <component
    name="legacy_component"
    displayName="Legacy Component (Classic Edition!)"
    version="0.9"
    file="./components/legacy/old_component/class.ptf"
  />
</library>
```

## Upgrading from Earlier Versions

If you specified a custom search path in SOPC Builder prior to v8.1 using the **IP Search Path** option, or by adding it to the `$SOPC_BUILDER_PATH`, SOPC Builder automatically adds those directories to the `user_components.ipx` file in your home directory. This file is saved in

`<home_dir>/altera.quartus/ip/8.1/ip_search_path/user_components.ipx`. Go to the **IP Search Path** option in the **Options** dialog box to see the directories listed here.

## Component Structure

Most components are defined with a `_hw.tcl` file, a text file written in the Tcl scripting language that describes the components in to SOPC Builder. You can add a component to SOPC Builder by either writing a Tcl description or you can use the component editor to generate an automatic Tcl description of it. This section describes the structure of Tcl components and how they are stored.



For details about the SOPC Builder component editor, refer to [Chapter 6, Component Editor](#). For details about the SOPC Builder Tcl commands, refer to [Chapter 7, Component Interface Tcl Reference](#).



## Component Description File (`_hw.tcl`)

A Tcl component consists of:

- A component description file, which is a Tcl file with file name of the form `<entity name>_hw.tcl`.
- Verilog HDL or VHDL files that define the top-level module of the custom component (optional).

The `_hw.tcl` file defines everything that SOPC Builder requires about the name and location of component design files.

The SOPC Builder component editor saves components in the `_hw.tcl` format. You can use these Tcl files as a template for editing components by hand. When you edit a previously saved `_hw.tcl` file, SOPC Builder automatically saves the earlier version as `_hw.tcl~`.

For more information about the information that you can include in the `_hw.tcl` file, refer to the [Chapter 7, Component Interface Tcl Reference](#).

## Component File Organization

A typical component uses the following directory structure. The precise names of the directories are not significant.

- `<component_directory>/`
  - `<hdl>/`—a directory that contains the component HDL design files and the `_hw.tcl` file
  - `<component name>_hw.tcl`—the component description file
  - `<component name>.v` or `.vhd`—the HDL file that contains the top-level module
  - `<component_name>_sw.tcl`—the software driver configuration file. This file specifies the paths for the `.c` and `.h` files associated with the component.
  - `<software>/`—a directory that contains software drivers or libraries related to the component, if any. Altera recommends that the software directory be subdirectory of the directory that contains the `_hw.tcl` file.

 For information on writing a device driver or software package suitable for use with the Nios<sup>®</sup> II IDE design flow, refer to the [Hardware Abstraction Layer](#) section of the *Nios II Software Developer's Handbook*. The [Nios II Software Build Tool Reference](#) chapter of the *Nios II Software Developer's Handbook* describes the commands you can use in the Tcl script.

## Component Versioning

You can create and maintain multiple versions of the same component using one of the following options:

- Define the module property version in your `_hw.tcl` file.

 For more information, refer to the [Chapter 7, Component Interface Tcl Reference](#).

- If multiple versions of the component are defined in your component libraries, you can add a different the version of a component by right-clicking on the component and selecting **Add version** <version\_number>.
- You can create an .ipx file in the same directory as your SOPC Builder project to control the search path for your project.

## Classic Components in SOPC Builder

If you use classic components created with an version 7.2 of SOPC Builder or earlier, read through this section to familiarize yourself with the differences. This document uses the term *classic components* to refer to class.ptf-based components created with a previous version of the Quartus II software. If you do not use classic components, skip this section.

Classic components are compatible with newer versions of SOPC Builder, but be aware of the following caveats:

- Classic components configured with the **More Options** tab in SOPC Builder, such as complex IP components provided by third-party IP developers, are not supported in the Quartus II software in version 7.1 and beyond. If your component has a bind program, you cannot use the component without recreating it with the component editor or with Tcl scripting.
- To make changes to a classic component with the component editor, you must first upgrade the component by editing the classic component and saving it in the `_hw.tcl` component format in the component editor.

This chapter describes the Quartus® II software features that are used with SOPC Builder, including the following:

- “Quartus II IP File”
- “Quartus II Incremental Compilation”
- “TimeQuest Timing Analyzer” on page 5-2

### Quartus II IP File

The Quartus II IP File (**.qip**) generated by SOPC Builder provides the Quartus II software with all required information about your SOPC Builder system. SOPC Builder creates the **.qip** during system generation and adds a reference to it in the Quartus II Settings File (**.qsf**).

The **.qip** file includes references to the following information:

- HDL files used in the SOPC Builder system
- TimeQuest Timing Analyzer Synopsys Design Constraint (**.sdc**) files
- Component definition files for archiving purposes

The **.qip** file is based on Tcl scripting syntax and is similar to the **.qsf** file. The information required to process most components is included in the system's single **.qip** file. Some complex components provide their own **.qip** file, in which case the system's **.qip** file references the component **.qip** file.



The **.qip** file is normally added to your project automatically by SOPC Builder. If it does not get added automatically you can add the file in the same way that you add other source files to your project. You can also have a **.qip** file for each component in your design. When you generate a design, each **.qip** is pulled into the main **.qip** file for your system by reference.

### Quartus II Incremental Compilation

SOPC Builder supports the Quartus II incremental compilation feature, which allows you to separately compile isolated portions, or partitions, of a design. From within the Quartus II software, you can designate an entire SOPC Builder system as a design partition, or you can designate individual SOPC Builder components as design partitions.



Changing the parameters of a component and regenerating your system only prompts other partitions within the same system to recompile if the HDL in that partition depends on the changed parameters. The HDL you generate for the Nios® II processor is optimized as related to components to which the Nios II processor is connected.

-  For more information about incremental compilation, refer to the *Quartus II Incremental Compilation for Hierarchical and Team-Based Design* chapter in volume 1 of the *Quartus II Handbook*.

## TimeQuest Timing Analyzer

Altera recommends the TimeQuest Timing Analyzer in the Quartus II software for analysis of all new designs. SOPC Builder automatically generates a TimeQuest `.sdc` constraints file for SOPC Builder systems and components. In most cases, you use the TimeQuest constraints to declare false paths for signals that cross clock domains within a component, so that the TimeQuest Timing Analyzer does not perform normal setup and hold analysis for them. You can add `.sdc` files for custom components, using **Add Files** command on **HDL Files** tab in the Component Editor. Turn on the **Synth** option and turn off the **Synth** option.

The Classic Timing Analyzer was primary in earlier versions of the Quartus II software. However, Altera now recommends that you constrain designs before compilation, because the TimeQuest Timing Analyzer reports any unconstrained paths by default during the compilation process.

-  Refer to the *Quartus II TimeQuest Timing Analyzer* chapter in volume 3 of the *Quartus II Handbook* for further description of the TimeQuest Timing Analyzer. Refer to the *Switching to the Quartus II TimeQuest Timing Analyzer* chapter in volume 3 of the *Quartus II Handbook* for a description of the benefits of using the TimeQuest Timing Analyzer rather than the Classic Timing Analyzer. Refer to *TimeQuest Example: Basic SDC Example* on [www.altera.com](http://www.altera.com) for a working example of using the TimeQuest Timing Analyzer. Refer to *TimeQuest Design Examples* on [www.altera.com](http://www.altera.com) for further details about how to constrain different types of circuits for the TimeQuest Timing Analyzer.

## Analyzing PLLs

You must constrain PLL clocks for proper analysis by the TimeQuest Timing Analyzer. You can define clocks generated by PLLs using one of the following methods:

- Use the `derive_pll_clocks` command to derive clocks for all PLL outputs in the design. This is the best method.
- Use the `create_generated_clock` command to designate each clock output.
- Use the `-create_base_clocks` option of the `derive_pll_clock` assignments to designate the base clock feeding the PLL.

The following example focuses on the use of the `derive_pll_clocks` assignment, because this method automatically defines clock frequencies and phase shifts.

-  `derive_pll_clocks` generates clocks for all PLLs in the Quartus II hardware project, not just for the PLLs in the SOPC Builder system.

The SOPC system shown in Figure 5-1 illustrates the use of the `derive_pll_clocks` assignment in the case of a single clock input and one PLL using a single output.

**Figure 5-1. Example SOPC System**

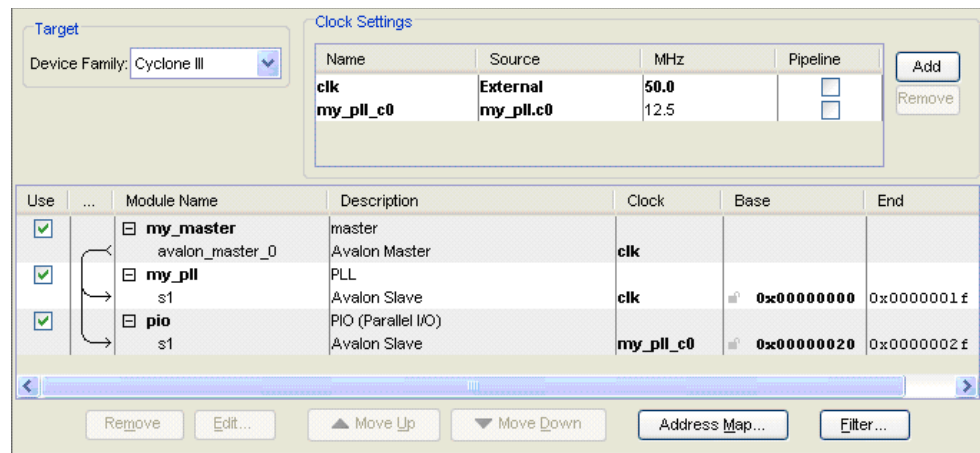

After running the following commands in the TimeQuest Timing Analyzer, two clocks are generated:

```
create_clock -name master_clk -period 20 [get_ports {clk}]
derive_pll_clocks
```

The TimeQuest Timing Analyzer analyzes and reports performance of the constrained clocks in the Clocks Summary report. This displays a report as shown in Figure 5-2.

**Figure 5-2. Clocks Summary Report**

Clocks Summary			
	Clock Name	Type	Period
1	master_clk	Base	20.000
2	the_my_pll the_pll altpll_component auto_generated pll1 clk[0]	Generated	80.000

`master_clk` is defined by the `create_clock` command, and `the_my_pll` clock is derived from the `derive_pll_clocks` command.

## Analyzing Slow Asynchronous I/O Paths

If you use slow asynchronous I/O in an SOPC Builder system, such as PIO and UART peripherals, you do not have to analyze these paths because they are asynchronous to the clock that is used to capture or output data. In this case you must designate false paths to produce an accurate analysis.

For outputs, set a false path between the launch clock and the output. For inputs, a false path should be set between the input and the latching clock. For bidirectional signals, set a false path from the launching clock to the bidirectional pin and also from the bidirectional pin to the latching clock. Launch and latch clocks are typically the clocks associated with the SOPC Builder module that includes the I/O.

For the system described in the PLL section, the following command sets false paths for the PLL outputs:

```
set_false_path -to [get_ports {*_pio[*]}]
```

Because design contains a 4-bit PIO, filter `*_pio[*]` includes the following I/O pins.

- `out_port_from_the_pio[0]`
- `out_port_from_the_pio[1]`
- `out_port_from_the_pio[2]`
- `out_port_from_the_pio[3]`

## Analyzing Single Data Rate SDRAM and SSRAM

Single data SDRAM interfaces in SOPC Builder typically use the type of circuit shown in Figure 5-3. You can use a PLL to fine tune the phase shift to the external memory to meet I/O timing requirements.

**Figure 5-3. Typical Single Data Rate SDRAM Circuit**

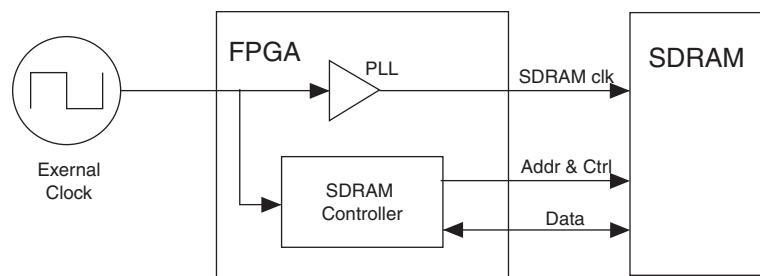

To constrain this interface, you must create a clock that is recognized by the external SDRAM; then you must set the I/O timing relative to that clock.

Example 5-1 shows how to constrain a PLL output clock and set a Tcl variable for that clock.

### Example 5-1. Constraining PLL Output Clock

```
create_clock -period 20.000 -name ext_clk [get_ports {clk}]
derive_pll_clocks
set sdram_clk\my_pll_inst|altpll_component|auto_generated|pll1|clk[0]
```

You can then use the `create_generated_clock` command to define a clock as recognized by the external memory. This generated clock automatically adds delays associated with routing to the clock output pin and the delay of the pin itself. You must also account for some board delay due to the PCB trace between the FPGA and SDRAM by using the `offset` option.

The following command shows the creation of the `sdram_clk_pin` generated clock derived from the output pin `sdram_clk` clock. A 0.5 ns offset accounts for PCB routing delay.

```
create_generated_clock -name sdr_clk_pin -source $sdr_clk \
-offset 0.5 [get_ports {sdr_clk}]
```

There may be some uncertainty associated with the PCB delay not accounted for in this command. The uncertainty can be included in the I/O constraints that are specific to input or output and minimum or maximum delays.

The I/O constraints must be defined in relation to the data sheet for the external memory. Figure 5-4 shows part of a data sheet for an SDRAM device with the worst case input and output timing highlighted for a CAS latency of 3.

**Figure 5-4. AC Characteristics from SDRAM Device Data sheet**

AC Characteristics Parameter	Symbol	-6		-7		Units	Notes
		Min	Max	Min	Max		
Access time from CLK (pos. edge)	CL = 3	<sup>t</sup> AC (3)	5.5	5.5	8	ns	
	CL = 2	<sup>t</sup> AC (2)	7.5	8	17	ns	
	CL = 1	<sup>t</sup> AC (1)	17	17		ns	
Address hold time		<sup>t</sup> AH	1	1		ns	
Address setup time		<sup>t</sup> AS	1.5	2		ns	
CLK high-level width		<sup>t</sup> CH	2.5	2.75		ns	
CLK low-level width		<sup>t</sup> CL	2.5	2.75		ns	
Clock cycle time	CL = 3	<sup>t</sup> CK (3)	6	7		ns	23
	CL = 2	<sup>t</sup> CK (2)	10	10		ns	23
	CL = 1	<sup>t</sup> CK (1)	20	20		ns	23
CKE hold time		<sup>t</sup> CKH	1	1		ns	
CKE setup time		<sup>t</sup> CKS	1.5	2		ns	
CS#, RAS#, CAS#, WE#, DQM hold time		<sup>t</sup> CMH	1	1		ns	
CS#, RAS#, CAS#, WE#, DQM setup time		<sup>t</sup> CMS	1.5	2		ns	
Data-in hold time		<sup>t</sup> DH	1	1		ns	
Data-in setup time		<sup>t</sup> DS	1.5	2		ns	
Data-out High-Z time	CL = 3	<sup>t</sup> HZ (3)	5.5	5.5	8	ns	10
	CL = 2	<sup>t</sup> HZ (2)	7.5	8	17	ns	10
	CL = 1	<sup>t</sup> HZ (1)	17	17		ns	10
Data-out Low-Z time		<sup>t</sup> LZ	1	1		ns	
Data-out hold time		<sup>t</sup> OH	2	2.5		ns	

The mapping of external memory timing to FPGA I/O delays is shown in Table 5-1. This table also shows whether the minimum or maximum PCB routing delay should be used, which must be added to the FPGA delay constraints.

**Table 5-1. External Memory Timing**

Memory Timing	FPGA Timing	PCB Routing
Max clock to out	Max input delay	Max
Min clock to out	Min input delay	Min
Min setup	Max output delay	Max
Min hold	Min output delay (-ve)	Min

**Note to Table 5-1:**

- (1) The constraint for minimum output delay is actually 0 – Min hold.

You can use the `set_input_delay` and `set_output_delay` commands to set the I/O constraints. In the following examples, a common PCB routing delay of  $0.5\text{ns} \pm 0.1\text{ns}$  is used, which adds a 0.4 ns or 0.6 ns delay to the paths. [Example 5-2](#) illustrates the use of these commands.

---

**Example 5-2. `set_input_delay` and `set_output_delay` commands**

---

```
set_input_delay -clock sdram_clk_pin -max [expr 5.5 + 0.6] <ports>
set_input_delay -clock sdram_clk_pin -min [expr 2.5 + 0.4] <ports>
set_output_delay -clock sdram_clk_pin -max [expr 2.0 + 0.6] <ports>
set_output_delay -clock sdram_clk_pin -min [expr -1 + 0.4] <ports>
```

---

In this example, `<ports>` represent a list of I/O ports for the relevant constraints as shown in [Example 5-3](#).

---

**Example 5-3. `<ports>`**

---

```
set_output_delay -clock sdram_clk_pin -max [expr 2.0 + 1.2] \
[get_ports {cas_n ras_n cs_n we_n addr[*]}]
```

---

You can use multiple `set_input_delay` and `set_output_delay` commands to set different delays for different I/O.

## Analyzing Tristate Bridges and Asynchronous Devices

This section discusses the timing constraints associated with the Avalon tristate bridge and asynchronous external devices, such as the CFI Flash and user tristate components. These components typically have slower performance requirements compared with the FPGA, and SOPC Builder generates logic within the interface to control timing across multiple clock cycles. You define the tristate component's timing parameters by entering data for setup, wait, and hold times.

For the interface types previously discussed, the timing is controlled by a state machine that is generated based on setup, wait, and hold settings you specify in the component editor. Because data sheet values for the FPGA are used in calculating the timing, the constraints simply ensure the data sheet timing is met. Adding these constraints ensures that issues associated with data sheet misinterpretation and fitting problems that affect I/O timing are captured.

The TimeQuest Timing Analyzer uses constraints that are based upon the timing of the external device.



For further information on how to convert older FPGA-centric constraints into system-centric constraints, refer to [Switching to the Quartus II TimeQuest Timing Analyzer](#) chapter in volume 3 of the *Quartus II Handbook*.



## Analyzing DDR and DDR2 Memories

When using DDR, DDR2, or DDR3 memory with Cyclone® III, Stratix® III, and Stratix IV families, you must use the corresponding High-Performance Controller MegaCore® function. You can use the MegaWizard™ Plug-In Manager interface to parameterize these functions and generate timing constraints in the form of .sdc files. You must ensure that the constraints file associated with the MegaCore function is included in the project for timing analysis. You can add an .sdc file to the project by clicking **Add/Remove Files in Project** on the Project menu in the Quartus II software.



As these MegaCore functions make use of the `derive_pll_clocks` command, conflicts may occur if your .sdc file also uses these constraints.



For more design examples, refer to [TimeQuest Design Examples](#) on [www.altera.com](http://www.altera.com). Also, *AN: 433 Constraining and Analyzing Source-Synchronous Interfaces* describes source synchronous constraints for the TimeQuest Timing Analyzer.



The SOPC Builder component editor provides a GUI to support the creation and editing of the Hardware Component Description File (`_hw.tcl`) file that describes a component to SOPC Builder. You use the component editor to do the following:

- Specify the Verilog HDL or VHDL files that describe the modules in your component hardware.
- Conversely, create an HDL template for a component by first defining its interface using the **HDL Files** tab of the component editor.
- Specify the signals for each of the component's interfaces, and define the behavior of each interface signal.
- Specify relationships between interfaces, such as determining which clock interface is used by a slave interface.
- Declare any parameters that alter the component structure or functionality, and define a user interface to let users parameterize instances of the component.

 For information about using the component editor in a development flow, refer to the following pages on the Altera® website: *SOPC Builder Component Development Flow Using the Component Editor Overview*. For information about Avalon® component interfaces, refer to *Avalon Component Interfaces Supported in the Component Editor Version 7.2 and Later*. For examples of changes to typical Avalon interfaces, refer to *Examples of Changes to Typical Avalon Interfaces for the Component Editor Version 7.2 and Later*. For information about upgrading components, refer to *Upgrading Your Component with SOPC Builder Component Editor Version 7.2 and Later*.

For information about the use of the component editor, see the following sections:

- “Starting the Component Editor” on page 6–2.
- “HDL Files Tab” on page 6–2.
- “Signals Tab” on page 6–3.
- “Interfaces Tab” on page 6–6.
- “HDL Parameters Tab” on page 6–6.
- “Saving a Component” on page 6–7.
- “Editing a Component” on page 6–8.
- “Component Parameterization” on page 6–8.

 For more information about components, refer to *Chapter 7, Component Interface Tcl Reference*. For more information about the Avalon-MM interface, refer to the *Avalon Interface Specifications*.

## Component Hardware Structure

The component editor creates components with the following characteristics:

- A component has one or more interfaces. Typically, an *interface* means an Avalon® Memory-Mapped (Avalon-MM) master or slave or an Avalon Streaming (Avalon-ST) source or sink. You can also specify exported component signals that appear at the top-level of the SOPC Builder system, which can be connected to logic outside the SOPC Builder system. The component editor lets you build a component with any combination of Avalon interfaces, which include:
  - Avalon-MM master and slave
  - Avalon-ST source and sink
  - Avalon-MM tristate slave
  - Interrupt sender and receiver
  - Clock input and output
  - Nios II custom instruction master and slave interfaces
  - Conduit (for exporting signals to the top level)
- Each interface is comprised of one or more signals.
- The component can represent logic that is instantiated inside the SOPC Builder system, or can represent logic outside the system with an interface to it on the generated system.

## Starting the Component Editor

To start the component editor in SOPC Builder, on the File menu, click **New Component**. When the component editor starts, the **Introduction** tab displays, which describes how to use the component editor.

The component editor presents several tabs that group related settings. A message window at the bottom of the component editor displays warning and error messages.



Each tab in the component editor provides on-screen information that describes how to use the tab. Click the triangle labeled **About** at the top-left of each tab to view these instructions. You can also refer to Quartus® II online Help for additional information about the component editor.

You navigate through the tabs from left to right as you progress through the component creation process.

## HDL Files Tab

The **HDL Files** tab allows you to create an SOPC Builder component from existing Verilog HDL or VHDL files, or to create an HDL template in either Verilog HDL or VHDL for a SOPC Builder component by first specifying its interfaces. The following sections describe both the bottom-up and top-down approaches to component design.

### Bottom-Up Design

You can use the **HDL Files** tab to specify Verilog HDL or VHDL files that describe the component logic. Files are provided to downstream tools such as the Quartus II software and ModelSim® in the same order as they appear in the table.

You can also use the component editor to define the interface to components outside the SOPC Builder system. In this case, you do not provide HDL files. Instead, you use the component editor to interactively define the hardware interface.

After you specify an HDL file, the component editor analyzes the file by invoking the Quartus II Analysis and Elaboration module. The component editor analyzes signals and parameters declared for all modules in the top-level file. If the file is successfully analyzed, the component editor's **Signals** tab lists all design modules in the **Top Level Module** list. If your HDL contains more than one module, you must select the appropriate top-level module from the **Top Level Module** list.

All files are managed in a single table, with options for **Synth** and **Sim**. You can select the **Top** option to select the top-level file for synthesis. When the top-level module is changed, the component editor performs best-effort signal matching against the existing port definitions. If a port is absent from the module, it is removed from the port list. You can use the up and down arrows to specify the HDL file analysis order.

By default, all files are added with both **Synth** and **Sim** options turned on. To add a simulation-only file, turn off the **Synth** option for that file. Files that turn on the **Sim** option are passed to ModelSim® for simulation. To add a synthesis-only file, turn off the **Sim** file option. Only files that you mark for **Synth** are added to the Quartus II IP File (.qip) for your project.



The component editor determines the signals on the component when only the top-level module or entity is added to the table, but all of the files required for the component must be added for the component to compile in Quartus II software or work in simulation.

## Top-Down Design

The **Create HDL Template** button on the **HDL Files** tab allows you to create an HDL template for a component if you have not provided a HDL description for it. Clicking the **Create HDL Template** button shows you the component HDL and lets you choose between Verilog HDL and VHDL. Altera recommends that you define your signals, interfaces, parameters and basic component information, including the component name, before creating the HDL template by clicking **Save**. The component editor writes `<component_name>.v` or `<component_name>.vhd` to your project directory.

After you have component the component's HDL code, you can add other files that are required to define your component, including the `_hw.tcl` file, and synthesis and simulation files using the **Add** button on the **HDL Files** tab.

## Signals Tab

You use the **Signals** tab to specify the purpose of each signal on the top-level component module. If you specified a file on the **HDL Files** tab, the signals on the top-level module appear on the **Signals** tab.

The **Interface** list also allows creation of a new interface so that you can assign a signal to a different interface without first switching to the **Interfaces** tab. Each signal must belong to an interface and be assigned a legal signal type for that interface. In addition to Avalon Memory-Mapped and Streaming interfaces, components typically have clock interfaces, interrupt interfaces, and perhaps a conduit interface for exported signals.

## Naming Signals for Automatic Type and Interface Recognition

The component editor recognizes signal types and interfaces based on the names of signals in the source HDL file, if they conform to the following naming conventions:

Signal associated with a specific interface—`<interface type>_<interface name>_<signal type>[_n]`

For any value of `<interface_name>` the component editor automatically creates an interface by that name, if necessary, and assigns the signal to it. The `<signal_type>` must match one of the valid signal types for the type of interface. Refer to the [Avalon Interface Specifications](#) for the signal types available for each interface type. You can append `_n` to indicate an active-low signal. [Table 6-1](#) lists the valid values for `<interface_type>`.

**Table 6-1. Valid Values for <Interface Type>**

Value	Meaning
avs	Avalon-MM slave
avm	Avalon-MM master
ats	Avalon-MM tristate slave
aso	Avalon-ST source
asi	Avalon-ST sink
cso	Clock output
csi	Clock input
coe	Conduit
inr	Interrupt receiver
ins	Interrupt sender
ncm	Nios II custom instruction master
ncs	Nios II custom instruction slave

**Example 6-1** shows a Verilog HDL module declaration with signal names that infer two Avalon-MM slaves.

---

**Example 6-1. Verilog HDL Module With Automatically Recognized Signal Names**

---

```
module my_slave_irq_component (

    // Signals for Avalon-MM slave port "s1" with irq

    csi_clockreset_clk; //clockreset clock interface
    csi_clockreset_reset_n; //clockreset clock interface

    avs_s1_address; //s1 slave interface
    avs_s1_read; //s1 slave interface
    avs_s1_write; //s1 slave interface
    avs_s1_writedata; //s1 slave interface
    avs_s1_readdata; //s1 slave interface
    ins_irq0_irq; //irq0 interrupt sender interface
);

input csi_clockreset_clk;
input csi_clockreset_reset_n;
input [7:0]avs_s1_address;
input avs_s1_read;
input avs_s1_write;
input [31:0]avs_s1_writedata;
output [31:0]avs_s1_readdata;
output ins_irq0_irq;

/* Insert your logic here */

endmodule
```

---

## Templates for Interfaces to External Logic

You can use the **Create HDL Template** to generate an HDL template for the component. Then, you connect these signals outside of the SOPC Builder system. If your component uses an Avalon interface to interface outside of SOPC Builder, you can use the Templates menu in the component editor to add typical interface signals to your signal list. There are templates for the following interfaces:

- Avalon-MM Slave
- Avalon-MM Slave with Interrupt
- Avalon-MM Master
- Avalon-MM Master with Interrupt
- Avalon-ST Source
- Avalon-ST Sink

After adding a typical Avalon interface using a template, you can add or delete signals to customize the interface.

## Interfaces Tab

The **Interfaces** tab allows you to configure the interfaces on your component and specify a name for each interface. The interface name identifies the interface and appears in the SOPC Builder connection panel. The interface name is also used to uniquely identify any signals that are ports on the top-level SOPC Builder system.

The **Interfaces** tab allows you to configure the type and properties of each interface. For example, an Avalon-MM slave interface has timing parameters that you must set appropriately. The **Interfaces** tab displays waveforms that illustrate the timing that you specified. If you update the timing parameters, the waveforms automatically update to illustrate the new timing. The waveforms are available for the following interface types:

- Avalon Memory-Mapped
- Avalon Memory-Mapped tristate
- Avalon Streaming
- Interrupts

If you convert a component from a **class.ptf** to a **\_hw.tcl** file, you may require three interfaces: a clock input, the Avalon slave, and an interrupt sender. A parameter in the interrupt sender must be set to reference the Avalon slave.

## HDL Parameters Tab

You specify the parameters that users of your component can set to configure your component on the **HDL Parameters** tab. The **Parameters** table included on this tab displays Verilog HDL parameters or VHDL generics that you declared in the top-level HDL module. Using the **Parameters** table, you can specify the following information about each parameter:

- Default value
- Whether or not it is user-editable
- Type
- Group
- Tool tip

Click **Preview the Wizard** at any time to see how the component GUI appears.

The following rules apply to HDL parameters exposed via the component GUI:

- Editable parameters cannot contain computed expressions.
- If a parameter  $\langle N \rangle$  defines the width of a signal, the signal width must be of the form  $\langle N-1 \rangle:0$ .
- When a VHDL component is used in a Verilog HDL SOPC Builder system, or vice versa, numeric parameters must be 32-bit decimal integers. When passing other numeric parameter types, unpredictable results occur.



Refer to [Chapter 7, Component Interface Tcl Reference](#) for detailed information about creating and displaying parameters using Tcl scripts.



## Library Info

The **Library Info** tab allows you to specify the following information about your component:

- **Display Name**—Specifies the user-visible name for this component in SOPC Builder.
- **Version**—Specifies the version number of the component.
- **Group**—Specifies which group in SOPC Builder displays your component in the list of available components. If you enter a previously unused group name, SOPC Builder creates a new group by that name.
- **Description**—Allows you to describe the component.
- **Created By**—Allows you to specify the author of the component.
- **Icon**—Allows you to place an image in the title bar of your component, in place of the MegaCore logo. The icon can be a **.jpg**, **.gif**, or **.png** file. The directory for the icon is relative to the directory that contains the **\_hw.tcl** file.
- **Documentation**—Allows you to specify multiple documents that pertain to your component. You can use this property to specify a file on the internet or in your company's file system. The specified file can be in either **.html** or **.pdf** format. To specify an internet file, begin your path with **http://**, for example: **http://mydomain.com/datasheets/my\_memory\_controller.html**. To specify a file in your company's file system, you begin your path with **file:///** for Linux and **file://** for Windows, for example: **file:///company\_server/datasheets/my\_memory\_controller.pdf**. For handwritten **\_hw.tcl** files, you can specify documentation using the `add_documentation_link` Tcl command.

 For more information refer to the `add_documentation_link` command in [Chapter 7, Component Interface Tcl Reference](#).

## Saving a Component

You can save the component by clicking **Finish** on any of the tabs, or by clicking **Save** on the File menu. Based on the settings you specify in the component editor, the component editor creates a component description file with the file name `<class-name>_hw.tcl`. The component editor saves the file in the same directory as the HDL file that describes the component's hardware interface. If you did not specify an HDL file, you can save the component description file to any location you choose.

You can relocate component files later. For example, you could move component files into a subdirectory and store it in a central network location so that other users can instantiate the component in their systems. The **\_hw.tcl** file contains relative paths to the other files, so if you move the **\_hw.tcl** file you should move all the HDL and other files associated with it.

 Altera recommends that you store **\_hw.tcl** files for a project in the `ip/<class-name>` directory for the project. You should store the HDL and other files in the same directory as the **\_hw.tcl** file.

## Editing a Component

After you save a component and exit the component editor, you can edit it in SOPC Builder. To edit a component, right-click it in the list of available components on the **System Contents** tab and click **Edit Component**.



You cannot edit components that were created outside of the component editor, such as Altera-provided components.

If you edit the HDL for a component and change the interface to the top-level module, you need to edit the component to reflect the changes you made to the HDL.

## Software Assignments

You can use Tcl commands to create software assignments. You can register any software assignment that you want, as arbitrary key-value pairs. [Example 6-2](#) shows a typical Tcl API script:

---

### Example 6-2. Typical Software Assignment with Tcl API Scripting

---

```
set_module_assignment name value  
set_interface_assignment name value
```

---

The assignments are added to the SOPC information file (**.sopcinfo**), available for use for downstream components.

## Component Parameterization

To edit component instance parameters, select a component in the **System Contents** tab of the SOPC Builder window and click **Edit**.

You define SOPC Builder components by declaring their properties and behaviors in a Hardware Component Description File (`_hw.tcl`). Each `_hw.tcl` file represents one component instance which you can add to an SOPC Builder system. You can also share the components that you design with other designers. For your component to have maximum flexibility, you should consider what aspects of its behavior can be parameterized so that other users can change the default parameterization to address different design requirements.

An SOPC Builder component is usually composed of the following four types of files:

- `_hw.tcl` file—describes the SOPC Builder related characteristics, such as interface behaviors. This file is required.
- HDL files—define the component’s functionality as hardware. These files are optional.
- `_sw.tcl`—used by the software build tools to compile the component driver code. This file is optional.
- Component driver files—defines the component register map and driver software to allow software to control the component. These files are optional.

This chapter discusses the following topics:

- [“Information in a Hardware Component Description File”](#)
- [“Component Phases” on page 7-2](#)
- [“Writing a Hardware Component Description File” on page 7-2](#)
- [“Overriding Default Behaviors” on page 7-8](#)
- [“Hardware Tcl Command Reference” on page 7-12](#)

### Information in a Hardware Component Description File

A typical `_hw.tcl` file contains the following information:

- Basic component information—includes the component’s name, version, and description, a link to its documentation, and pointers to HDL implementation files for synthesis and simulation.
- Parameter Declarations—Parameters are values that the user of your component can set that affect how the component is implemented, such as the size of a memory. Properties of each parameter include the parameter’s name, whether or not it is visible, and, if visible, the text to display when describing it. When the SOPC Builder system is generated, the parameters can be applied to the component as Verilog HDL parameters or VHDL generics.
- Interface Properties—The interfaces of a component define how to connect it to the rest of the system and determine how other components in the system interact with it. When you add interfaces to a component, you declare which signals make up each interface. You also define interface properties, such as wait states for an Avalon® Memory-Mapped (Avalon-MM) interface.

Depending on your component design, your `_hw.tcl` file may be one of the following two types:

- **Static**—A static `_hw.tcl` file defines the top-level HDL file and associated component files. The HDL that describes a static component is created by the component author and is not changed by users of the component. HDL parameters are available when instantiating the component.
- **Generated**—A generated `_hw.tcl` file provides a user-defined program to generate the component's HDL. The HDL can be different for different parameterizations of the component.

## Component Phases

The following section describes the distinct phases in the development of an SOPC Builder component.

- **Main Program**—SOPC Builder first discovers a component and adds it to the component library. The `_hw.tcl` file is executed and the Tcl statements provide non-instance-specific information to SOPC Builder. During this phase, some component interfaces may be incompletely described and ports may have a width of 0 or -1 to indicate that they are variable.
- **Validation**—Validation allows the component to generate error, warning, or informational messages. Validation occurs when an instance of a component is created, when its parameters are changed, or when some other property of the system is changed.
- **Elaboration**—Elaboration occurs as SOPC Builder queries a component for its interface information. Elaboration typically occurs immediately after validation and before generation. Interfaces defined in the main program can be enabled or disabled during elaboration. Depending on the validation callback code, elaboration and validation may alternate a few times. Elaboration and validation always occur before generation. Once elaboration is complete, the component must be completely described. For example, all port widths must have positive values.
- **Generation**—Generation creates all the information that the Quartus® II software and HDL simulator require. The required files typically include VHDL or Verilog HDL files, simulation models, timing constraints, and other information.
- **Editor**—After an instance of your component has been added to an SOPC Builder system, allows the user of your component to edit the GUI that displays the parameterization. You can change the appearance of the default editor to make it easier to use.

## Writing a Hardware Component Description File

This section provides detailed information about `_hw.tcl` files and describes the default behavior of a component in all phases. The following example uses a simple UART with some simple parameterization.

## Providing Basic Information

A typical `_hw.tcl` file first declares basic information such as the name, location, and the files it includes. The first command in a `_hw.tcl` file should specify the version of the `_hw.tcl` API to use, with the following Tcl command:

```
package require -exact socp <version>
```

The version number is a Quartus II release version such as 10.0. SOPC builder guarantees that a valid `_hw.tcl` file that requests a particular `socp` package behaves identically in future versions of the tool. Because of differences between versions of the Quartus II software, you cannot assume that an HDL file that works with one `socp` package automatically works with other versions of the package.



This chapter describes the behavior of components that request the `socp 10.0` package. For earlier releases, refer to the documentation for that release.



An excellent source of information about Tcl syntax is the [Tcl Developer Xchange](#) website.

---

### Example 7-1. Basic Information for `_hw.tcl` File

---

```
# The package command must be the first command in the file
package require -exact socp 10.0

# The name and VERSION of the component
set_module_property NAME example_uart
set_module_property VERSION 1.0

# The name of the component to display in the library
set_module_property DISPLAY_NAME "Example Component"

# The component's description.
set_module_property DESCRIPTION "An Example Component"

# The component library group that component belongs to
set_module_property GROUP Examples
```

---

## Declaring Parameters

By including configuration parameters in your `_hw.tcl` file, you allow users of your component to parameterize it in different ways. Each parameter has a number of properties such as its name, type, display name, and default value that can be used to control how the parameter is displayed and used. [Example 7-2](#) illustrates the use of parameters that can be configured by users of your component.

---

### Example 7-2. Declaring Parameters

---

```
# Declare Baud Rate parameter as an integer with a default value of 9600.
add_parameter BAUD_RATE int 9600

# Display this parameter as "Baud Rate" in the Parameter Editor.
set_parameter_property BAUD_RATE DISPLAY_NAME "Baud Rate (bps)"

# We only support three baud rates
set_parameter_property BAUD_RATE ALLOWED_RANGES {9600 19200 38400}
```

---

Parameters can be divided into three types: user parameters, system information parameters and derived parameters. The following sections describe these parameter types.

### User Parameters

User parameters are parameters that users have control over and that are exposed in the component GUI.

### Derived Parameters

Derived parameters are parameters that are inferred by the component itself from user parameters or other derived parameters. For example, a clock period parameter can be derived from a data rate parameter.

### SYSTEM\_INFO Parameters

You can use `SYSTEM_INFO` parameter to request that certain parameter values are populated with information about the system. For example, you might want to know the frequency of the clock that ends up being connected to your clock input. When you declare `SYSTEM_INFO` properties, you provide an `<info-type>` and further arguments. The `<info-type>` is the type of information you want, such as `clock_rate`, and you use the additional arguments to specify things, such as which clock input interface you require. [Example 7-3](#) illustrates the use of the `SYSTEM_INFO` parameter. For more information about the `SYSTEM_INFO` parameter properties refer to [Table 7-5 on page 7-26](#)

#### Example 7-3. Syntax of Tcl Command using the SYSTEM\_INFO Parameter

---

```
set_parameter_property my_parameter SYSTEM_INFO {<info-type> [<arg>]}
```

---

## Declaring Interfaces

To declare an interface, use the `add_interface` command. Then use the `set_interface_property` and `add_interface_port` commands to set its properties and indicate which signals belong to it. The interface declaration statement includes the name of the interface, the interface direction, and the clock interface with which it is associated. For interfaces that are not associated with clocks (such as clock interfaces themselves), omit the associated clock interface, or use the word *asynchronous*.

[Example 7-4](#) illustrates interface declaration.

### Example 7-4. Declare Interfaces

```
# Declare the clock sink interface, "clock_sink", type=clock, direction=sink
add_interface clock_sink clock sink

# The clock interface has two signals, named "clk" and "reset_n" of types "clk" "reset_n"
add_interface_port clock_sink clk clk input 1
add_interface_port clock_sink reset_n reset_n input 1

# Declare the Avalon slave interface, name=avalon_slave_0, type=avalon,
# direction=slave, associated with the clock_sink clock interface.
add_interface avalon_slave_0 avalon slave clock_sink

# Set a number of properties about the Avalon Slave interface
set_interface_property avalon_slave_0 writeWaitTime 0
set_interface_property avalon_slave_0 addressAlignment DYNAMIC
set_interface_property avalon_slave_0 readWaitTime 1
set_interface_property avalon_slave_0 readLatency 0

# Declare all the signals that belong to my Avalon Slave interface
add_interface_port avalon_slave_0 my_readdata readdata output 8
add_interface_port avalon_slave_0 my_read read input 1
add_interface_port avalon_slave_0 my_write write input 1
add_interface_port avalon_slave_0 my_waitrequest waitrequest output 1
add_interface_port avalon_slave_0 my_address address input 24
add_interface_port avalon_slave_0 my_writedata writedata input 8
```

## Adding Files and Guiding Generation

Component description files typically provide all of the information required for generation and downstream tools. You also identify which of the added files is the top-level HDL file and specify which Verilog module or VHDL entity within that file is the top-level module for the component. [Example 7-5](#) illustrates the files that are typically required for generation and downstream tools.

### Example 7-5. Add Files

```
# Add the HDL file to the component, to be used for synthesis and simulation.
add_file simple_uart.v {SYNTHESIS SIMULATION}

# Indicate which of the added HDL files holds the top-level module/entity
# that describes the component, name of the top-level module/entity
set_module_property TOP_LEVEL_HDL_FILE simple_uart.v
set_module_property TOP_LEVEL_HDL_MODULE simple_uart
```

## Default Behaviors

The `_hw.tcl` file described in the previous section has default behaviors during the editor, validation, elaboration, and generation phases. These default behaviors apply to instances of a component. This section describes the default SOPC Builder behaviors for each of these phases. To override these default behaviors, refer to [“Overriding Default Behaviors” on page 7-8](#).

### Validation Phase Behavior

SOPC Builder’s default validation checks each parameter value against its `ALLOWED_RANGES` property. If the values specified are outside the allowed ranges, an error message is displayed.

The `ALLOWED_RANGES` property of each parameter is a list of ranges that the parameter can take on, where each range is a single value, or a range of values defined by a start and end value separated by a colon. [Table 7-1](#) shows some examples of values the `ALLOWED_RANGES` property can take.

**Table 7-1. ALLOWED\_RANGES Property**

ALLOWED_RANGES	Meaning
{a b c}	a or b or c
{1 2 4 8 16}	1, 2, 4, 8, or 16.
1:3	1 through 3, inclusive
{1 2 3 7:10}	1, 2, 3, or 7 through 10 inclusive

### Elaboration Phase Behavior

If the main program does not explicitly define the widths of all ports to constant values or to an expression, then SOPC Builder’s default elaboration process calls `quartus_map` to determine the correct port widths. If you define all port widths in the main program, `quartus_map` is not called.

#### Automatic Port Widths

When port widths are not specified, or have a value of `'-1'`, `quartus_map` is used to determine port widths as a function of the parameter set. While this process makes authoring a component easier, SOPC Builder can end up spending a lot of time calling `quartus_map`. When using automatic port widths, you can indicate that a certain parameter does not affect any port widths or interfaces by setting that parameter's `affects_elaboration` property to `false`, meaning that `quartus_map` is not called when the parameter's value is changed by your user. Be careful with this— indicating that a parameter does not affect elaboration when it really does can lead to problems that are mysterious and difficult to debug.

As an alternative to the automatic port widths, you can set port widths to simple HDL expressions using the `width_expr` property. `width_expr` is a string that holds an expression describing the port width. By using the `width_expr` property, you can define port widths as an expression that is evaluated without needing to analyze the HDL file or set them in an elaboration callback. The syntax for width expressions is the same as the HDL language that you use; however, only the addition, subtraction,



multiplication, and division operators are allowed. For more complex port widths, the width of the port can be set as an arbitrary function of the component's parameters in an elaboration callback. The width expression is the last argument to the `add_interface_port` command. [Example 7-6](#) illustrates the use of mathematical operators and the `width_expr` property.

#### Example 7-6. Defining Port Widths Using Simple Mathematical Operators

```
add_interface_port din din_data data input {WIDTH * SYMBOLS}  
set_port_property din_data width_expr WIDTH
```

### Parameterized Parameter Widths

For VHDL users, SOPC Builder allows a `std_logic_vector` parameter to have a width that is defined by another parameter. When adding a parameter of type `std_logic_vector` you can also specify its width as a parameter property. The width can be a constant or the name of another parameter. The commands below add a `std_logic_vector` parameter called `myParameter` whose width is set by another parameter, called `dataWidth`.

```
add_parameter myParameter STD_LOGIC_VECTOR  
set_parameter_property myParameter WIDTH dataWidth
```

## Generation Phase Behavior

SOPC Builder's default generation does one of the following:

- If the component defines the `TOP_LEVEL_HDL_MODULE` property, SOPC Builder creates a Verilog HDL or VHDL wrapper module to instantiate the top-level module and applies the parameters as selected by the user of your component. SOPC Builder does not apply parameters in the wrapper if they are not declared in the underlying HDL file.

*or*

- If the component does not define the `TOP_LEVEL_HDL_MODULE` property, but instead sets the `INSTANTIATE_IN_SYSTEM_MODULE` module property to `false`, the module is not instantiated inside the SOPC Builder system and a wrapper file is not created. Rather, the interface to the module is exported to the top-level of the SOPC Builder system, and the module must be connected outside the system.

## Edit Phase Behavior

SOPC Builder's default editor phase behavior is to use all of the parameter definitions to display the parameter editor. The properties of the parameters guide SOPC Builder when it builds the default GUI. [Table 7-4 on page 7-23](#) lists the properties of parameters.

You can place parameters in logical groups and provide images and text to create a custom GUI for your component. [Example 7-7](#) defines four parameters and illustrates the use of the `add_display_item` command and the `DISPLAY_HINT` and `ALLOWED_RANGES` parameters.

### Example 7-7. Defining and Customizing GUI Parameters

```
# provide an icon for the sound group
add_display_item icon Speaker speaker-image speaker.png
add_parameter sound string 0 0
add_parameter volume_control boolean 0 0
add_parameter separate_control string 0 0

# Setup display_names for the parameters
set_parameter_property sound DISPLAY_NAME Audio
set_parameter_property volume_control DISPLAY_NAME "Include Volume Control Interface"
set_parameter_property separate_control DISPLAY_NAME "Treble/Bass Controls"

# Display all parameters in the Speaker group
add_display_item Speaker sound parameter
add_display_item Speaker volume_control parameter
add_display_item Speaker separate_control parameter

# There are 4 choices for the sound parameter.
# Strings with internal spaces require double quotes
set_parameter_property sound ALLOWED_RANGES {"0:No Audio" 1:Monophonic 2:Stereo
4:Quadraphonic}
set_parameter_property separate_control ALLOWED_RANGES {"No Control" "Single Control" "Dual
Controls"

#Specify how parameters should be displayed
set_parameter_property volume_control DISPLAY_HINT boolean
set_parameter_property separate_control DISPLAY_HINT radio
```

[Figure 7-1](#) shows the GUI that the Tcl commands in [Example 7-13](#) produces.

**Figure 7-1. Parameter GUI for Audio Component**

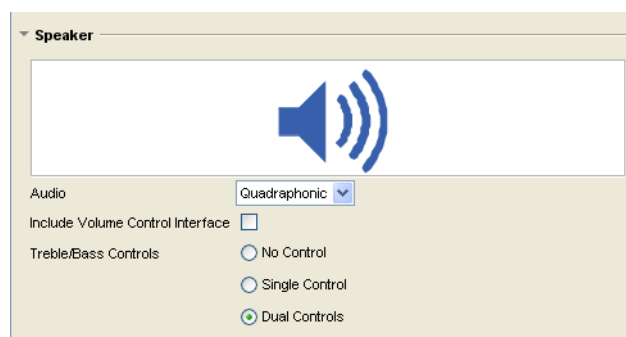

## Overriding Default Behaviors

You can override each of the default behaviors by using callbacks. This section explains how to write callback procedures for each phase of component development.

## Validation Callback

You can use the validation callback to provide validation that extends beyond the default range checking. A validation callback is defined by setting the `VALIDATION_CALLBACK` module property to be the name of the validation callback procedure, as shown in [Example 7-8](#). This validation procedure displays an error if you select a baud rate of 38400 and odd parity.

You can also use the validation callback to set the value of derived parameters. Derived parameters are parameters that are derived from other parameters; their values are not editable and are not saved in the SOPC Builder design file (`.sopc`). You indicate that a parameter is derived by setting the parameter's `DERIVED` property to true. In [Example 7-8](#) `BAUDRATE_PRESCALE` is a derived parameter whose value is 1/16 of the value of the `BAUDRATE` parameter.

### Example 7-8. Custom Validation Callback Function

---

```
# Declare the validation callback.
set_module_property VALIDATION_CALLBACK my_validation_callback

# Add the BAUDRATE_PRESCALE parameter, and indicate that it's derived
add_parameter BAUDRATE_PRESCALE int 600
set_parameter_property BAUDRATE_PRESCALE DERIVED true

# Add the PARITY parameter
add_parameter PARITY string ODD
set_parameter_property PARITY ALLOWED_RANGES {EVEN ODD}

# The validation callback
proc my_validation_callback {} {
    # Get the current value of parameters we care about
    set br [get_parameter_value BAUD_RATE]
    set p [get_parameter_value PARITY]
    # Display an error for invalid combinations.
    if {($br==38400) && ($p=="ODD")} {
        send_message warning "Odd parity at 38400 bps is not supported."
    }
    # Set the value of our DERIVED parameter
    set bp [expr $br / 16]
    set_parameter_value BAUDRATE_PRESCALE $bp
}
```

---

## Elaboration Callback

You can use an elaboration callback to change interface properties or add new interfaces as a function of parameter values. You define an elaboration callback by setting the `ELABORATION_CALLBACK` module property to the name of the elaboration callback function, as shown in [Example 7-9](#). You can enable and disable interfaces from the elaboration callback if they are only needed for some parameterizations of the component. [Example 7-9](#) shows how an Avalon-MM slave interface can be included in an instance of the component, based on the `USE_STATUS_INTERFACE` parameter. All of the functionality available in the validation callback can also be used in the elaboration callback; separate callbacks for validation and elaboration are not required.



The elaboration callback will not be called when parameters with `AFFECTS_ELABORATION=false` are changed by the user of the component.

### Example 7-9. Elaboration Callback

```
# Declare the callback.
set_module_property ELABORATION_CALLBACK my_elaboration_callback

# Add the USE_STATUS_INTERFACE parameter
add_parameter USE_STATUS_INTERFACE boolean

# Declare the status slave interface
add_interface_status_slave avalon_slave clock_sink
set_interface_property status_slave ENABLED false

# The elaboration callback
# Declare signals
add_interface_port status_slave st_readdata readdata output 16
add_interface_port status_slave st_read read input 1
add_interface_port status_slave st_write write input 1
add_interface_port status_slave st_waitrequest waitrequest output 1
add_interface_port status_slave st_address address input 24
add_interface_port status_slave st_writedata writedata input 16

# The elaboration callback
proc my_elaboration_callback {} {

    # Get the current value of parameters we care about
    set use_status [get_parameter_value USE_STATUS_INTERFACE]

    # Optionally add the status interface
    if { $use_status } {
        set_interface_property status_slave ENABLED true
    }
}
```

## Generation Callback

If you define a generation callback, SOPC Builder does not generate an HDL wrapper file to apply parameter values to your component. Instead, it calls the generation callback you defined during the generation phase, allowing the component to programmatically generate its HDL. A generation callback is defined by setting the `GENERATION_CALLBACK` module property to be the name of the generation callback function, as [Example 7-10](#) illustrates.

Generation callbacks typically retrieve the current value of the component's parameters and the generation properties that guide the generation process, and then generate the HDL files and supporting files in Tcl or by calling an external program. The callback procedure also reports the required files to SOPC Builder with the `add_file` command. Any files added in the generation callback are in addition to the files added in the main body of the `_hw.tcl` file.

The generation callback must write `<output_name.v>` or `.sv` for Verilog or `<output_name.vhd>` for VHDL to the specified `<output_directory>`. This file is a parameterized instance of the component. Other supporting files, such as `.hex` files to initialize memory, may be written to `<output_directory>`. These file names must begin with `<output_name>`. If the supporting files are the same for all parameterizations of the component, you add them from the main program rather than the generation

callback. If your system includes multiple instantiations of a component with different parameterizations, you must add the supporting files from the main program to prevent failures. If a static supporting file is only needed in some parameterizations of the component, you should add it from the main program and turn it on or off by setting its `SYNTHESIS` and `SIMULATION` properties appropriately from the elaboration callback.

### Example 7-10. Generation Callback Example

```
set_module_property GENERATION_CALLBACK my_generate
# My generation method
proc my_generate {} {
    send_message info "Starting Generation"

    # get generation settings

    set language [get_generation_property HDL_LANGUAGE]
    set outdir [get_generation_property OUTPUT_DIRECTORY ]
    set outputname [get_generation_property OUTPUT_NAME ]

    # get parameter values

    set p1 [get_parameter_value PARAMETER_ONE]
    set csr [get_parameter_value CSR_ENABLED]

# Your callback needs to write $outdir$outputname.v here,
# perhaps by using exec to call an external program.

# add_file creates files relative to the _hw.tcl directory; therefore specify $outdir
# for synthesis and simulation files

exec perl my_generate.pl lang=$language dir=$outdir name=$outputname p1=$p1 csr=$csr
add_file ${outdir}${outputname}.v SYNTHESIS
add_file ${outdir}${outputname}_sim.v SIMULATION
}
```

## Editor Callback

You can use the editor callback procedure to replace the parameterization GUI. An editor callback is defined by setting the `EDITOR_CALLBACK` module property to the name of your editor callback procedure, as shown in the [Example 7-11](#). If the editor callback is defined, SOPC Builder calls the editor callback instead of displaying the parameterization GUI, typically when the component is added to a system or updated after it is in the system.

To display your custom GUI, the editor callback must call another program. Typically, an editor callback provides the current parameter values to your program via the command line and collects the new parameter values via `stdout`. The editor callback then uses the `set_parameter_value` command to update SOPC Builder with the new parameter values.

The editor callback returns one of the following three values:

- `OK`—indicates that the results of the edit should be applied.
- `CANCEL`—indicates that the system should revert to the state it was in before the editor callback was called.
- `ERROR`—indicates that the GUI was unable to launch. An appropriate error message should be displayed.

If no value is returned, OK is assumed.

### Example 7-11. Editor Callback

---

```

set_module_property EDITOR_CALLBACK my_editor

# Define Module parameters.
add_parameter PARAMETER_ONE integer 32 "A parameter"
add_parameter CSR_ENABLED boolean true "Enable CSR interface"

# My editor method
proc my_editor {} {
# get parameter values
  set p1 [ get_parameter_value PARAMETER_ONE ]
  set csr [ get_parameter_value CSR_ENABLED ]

  # Display UI, populated with current parameter values.
  # The stdout returned by the UI program includes the new parameter values.
  set result [exec my_component_ui.exe p1=$p1 csr=$csr]

  # Use the fictional "parse_for_new_value" procedure to parse the returned text for the
  # new parameter values.
  set p1 [parse_for_new_value $result p1]
  set csr [parse_for_new_value $result csr]

# Return the new parameter values to SOPC Builder
  set_parameter_value PARAMETER_ONE $p1
  set_parameter_value CSR_ENABLED $csr
  return OK
}

```

---

## Hardware Tcl Command Reference

This section provides a reference for all hardware Tcl commands, as follows:

- [“Module Definition” on page 7-14](#)
- [“Parameters” on page 7-21](#)
- [“Display Items” on page 7-29](#)
- [“Interfaces and Ports” on page 7-32](#)
- [“Generation” on page 7-38](#)

The description of each command indicates during which phases it is available: in the main body of the program (main), or during the validation, elaboration, generation, and editor callback phases, or any combination. [Table 7-2](#) summarizes the commands and provides a reference to the full description.

 Starting with Quartus II software version 9.1, all Tcl commands that you can use in the validation callback are also available in the elaboration callback. With this change, you may be able to omit the custom validation callback by including some validation commands in your elaboration callback.

**Table 7-2. Command Summary (Note 1) (Part 1 of 2)**

Command	Full Description
<b>Module Definition</b>	
package <require> -exact socp <version>	page 7-14
get_module_properties	page 7-15
get_module_property <propertyName>	page 7-16
set_module_property <propertyName> <propertyValue>	page 7-17
get_module_ports	page 7-17
get_module_assignments	page 7-17
get_module_assignment <moduleName>	page 7-18
set_module_assignment <moduleName> [value]	page 7-18
get_files	page 7-18
add_file filename [<fileProperties>...]	page 7-19
add_documentation_link <docType> <title> <fileOrUrl>	page 7-19
get_file_properties	page 7-20
get_file_property <filename> <propertyName>	page 7-20
set_file_property <filename> <propertyName> <propertyValue>	page 7-20
send_message <messageLevel> <messageText>	page 7-21
<b>Parameters</b>	
add_parameter <parameterName> <parameterType> [<defaultValue> <description>]	page 7-22
get_parameters	page 7-22
get_parameter_properties	page 7-23
get_parameter_property <parameterName> <propertyName>	page 7-27
set_parameter_property <parameterName> <propertyName> <value>	page 7-27
get_parameter_value <parameterName>	page 7-28
set_parameter_value <parameterName> <value>	page 7-28
decode_address_map <address_map_XML_string>	page 7-28
<b>Display Items</b>	
add_display_item <groupName> <id> <type> [<additionalInfo>]	page 7-29
GET_DISPLAY_ITEMS	page 7-31
GET_DISPLAY_ITEM_properties	page 7-31
GET_DISPLAY_ITEM_PROPERTY <itemName> <propertyName>	page 7-31
set_display_item_PROPERTY <itemName> <propertyName> <value>	page 7-31
<b>Interfaces and Ports</b>	
add_interface <interfaceName> <interfaceType> <direction> [<associatedClock>]	page 7-33

**Table 7-2. Command Summary (Note 1) (Part 2 of 2)**

Command	Full Description
<code>get_interfaces &lt;interfaceName&gt;</code>	page 7-33
<code>get_interface_property &lt;interfaceName&gt; &lt;propertyName&gt;</code>	page 7-34
<code>set_interface_property &lt;interfaceName&gt; &lt;propertyName&gt; &lt;value&gt;</code>	page 7-35
<code>add_interface_port &lt;interfaceName&gt; &lt;portName&gt; &lt;portRole&gt; [&lt;direction&gt; &lt;width_expr&gt;]</code>	page 7-35
<code>get_interface_ports [&lt;interfaceName&gt;]</code>	page 7-36
<code>get_port_properties</code>	page 7-36
<code>get_port_property &lt;portName&gt; &lt;propertyName&gt;</code>	page 7-37
<code>set_port_property &lt;portName&gt; &lt;propertyName&gt; [&lt;value&gt;]</code>	page 7-37
<code>get_interface_assignments</code>	page 7-38
<code>get_interface_assignment &lt;interfaceName&gt; &lt;name&gt;</code>	page 7-38
<code>set_interface_assignmet &lt;interfaceName&gt; &lt;name&gt; [&lt;value&gt;]</code>	page 7-38
<b>Generation</b>	
<code>get_generation_property &lt;propertyName&gt;</code>	page 7-39
<code>get_generation_properties</code>	page 7-39

**Note to Table 7-2:**

(1) Arguments enclosed in []'s are optional

## Module Definition

This section provides information about the commands that you use to define and query a module.

### package

The `package` command allows you to specify a particular version of the SOPC Builder software to avoid software compatibility issues. You should use the `package` command at the beginning of your `_hw.tcl` file. When used, the component files behave as if they are interpreted by the version of the SOPC Builder software that you specify. When the `package` command is not used, version 9.0 of the SOPC Builder software is assumed. For components designed before 9.0, you can set the required package to 9.0. This document describes the behavior of component which start with `package require -exact socp 10.0` For earlier releases, refer to the documentation for that release.



`package` is a standard Tcl command. For more information on this command refer to the following web page: <http://www.tcl.tk/man/tcl8.0/TclCmd/package.htm>

<b>package</b>	
Callback availability	Main (before any other commands in the file)
Usage	<code>package require -exact socp &lt;version&gt;</code>
Returns	None



<b>package</b>		
Arguments	version	The version of SOPC Builder that you require, specified as decimal number
Example	package require -exact socp 10.0	

### get\_module\_properties

This command returns the names of all the available module properties as a list of strings. You can use the `get_module_property` and `set_module_property` commands to get and set values of individual properties. The value returned by this command is always the same for a particular version of SOPC Builder.

<b>get_module_properties</b>	
Callback availability	Main, validation, elaboration, generation, and editor
Usage	<code>get_module_properties</code>
Returns	List of strings
Arguments	None
Example	<code>get_module_properties</code>

Table 7-3 lists the available module properties, their use, and the phases in which they can be set.

**Table 7-3. Module Properties (Part 1 of 2)**

Property Name	Property Type	Can Be Set	Description
AUTHOR	String	Main program	The module's author.
DESCRIPTION	String	Main program	The description of the module, such as "Example SOPC Builder Module."
DISPLAY_NAME	String	Main program	The name to display when referencing the module, such as "My SOPC Component."
EDITABLE	Boolean	Main program	Indicates if the component is editable in the component editor.
EDITOR_CALLBACK	String	Main program	The name of the editor callback. The default parameterization UI is displayed if this property is not set.
ELABORATION_CALLBACK	String	Main program	The name of the elaboration callback. For static and generated components, the default elaborations used if this property is not set.
GENERATION_CALLBACK	String	Main program	The name of the generation callback.
GROUP	String	Main program	The component group that the module belongs to, such as "Example Components."
ICON_PATH	String	Main program	A path to an icon to display in the module's parameter editor.

**Table 7-3. Module Properties (Part 2 of 2)**

Property Name	Property Type	Can Be Set	Description
INSTANTIATE_IN_SYSTEM_MODULE	Boolean	Main program	When <code>false</code> the instances of the module are not included in the generated system interconnect fabric. Instead, interfaces to the module are exported out of the top-level of the SOPC Builder system.
MODULE_DIRECTORY	String	Can only be read, not set	The directory containing the <code>_hw.tcl</code> file. All relative file names within the Tcl file are resolved relative to this directory. This directory is set as the current directory when running the main program or a callback.
MODULE_TCL_FILE	String	Can only be read, not set	The path to the <code>_hw.tcl</code> file.
NAME	String	Main program	The name of the module, such as <code>my_sopc_component</code> .
TOP_LEVEL_HDL_FILE	String	Main program	Indicates which of the files added by the <code>add_file</code> command contains the module's top-level HDL.
TOP_LEVEL_HDL_MODULE	String	Main program	Indicates the name of the top-level module which must be defined in the module's top-level HDL file.
VALIDATION_CALLBACK	String	Main program	The name of the validation callback. This callback is run in addition to the default validation.
VERSION	String	Main program	The module's version, such as 8.1.



The `INSTANTIATE_IN_SYSTEM_MODULE`, `TOP_LEVEL_HDL_MODULE` and `GENERATION_CALLBACK` commands are used to select the type of generation used by the component. You must set only one of these in the main program of your file.

### **get\_module\_property**

This command returns the value of a single module property.

<b>get_module_property</b>	
Callback availability	Main, validation, elaboration, generation, and editor
Usage	<code>get_module_property &lt;propertyName&gt;</code>
Returns	String, boolean, or file
Arguments	<code>propertyName</code>   One of the properties listed in <a href="#">Table 7-3 on page 7-15</a>
Example	<code>set my_name [get_module_property NAME]</code>

## set\_module\_property

This command allows you to set the values for module properties.

set_module_property		
Callback availability	Main program	
Usage	set_module_property <propertyName> <propertyValue>	
Returns	None	
Arguments	propertyName	One of the properties listed in <a href="#">Table 7-3 on page 7-15</a>
	propertyValue	The new value of the property
Example	set_module_property VERSION 10.0	

## get\_module\_ports

This command returns a list of the names of all the ports which are currently defined.

get_module_ports	
Callback availability	Main, validation, elaboration, generation, and editor
Usage	get_module_ports
Returns	String
Arguments	None
Example	get_module_ports

## get\_module\_assignments

This command returns names of the module assignment variables.

get_module_assignments	
Callback availability	Main, validation, elaboration, and compose
Usage	get_module_assignments
Returns	String
Arguments	None
Example	get_module_assignments

**get\_module\_assignment**

This command returns the value of the specified argument. You can use the `get_module_assignment` and `set_module_assignment` and the `get_interface_assignment` and `set_interface_assignment` commands to transfer information about hardware components to embedded software tools and applications.

<b>get_module_assignment</b>			
Callback availability	Main, validation, elaboration, and compose		
Usage	<code>get_module_assignment &lt;name&gt;</code>		
Returns	String		
Arguments	<table border="1"> <tr> <td>name</td> <td>The name whose value is being retrieved</td> </tr> </table>	name	The name whose value is being retrieved
name	The name whose value is being retrieved		
Example	<code>get_module_assignment embedded.sw.CMacro.colorSpace</code>		

**set\_module\_assignment**

This command sets the value of the specified argument.

<b>set_module_assignment</b>					
Callback availability	Main, validation, elaboration, and compose				
Usage	<code>set_module_assignment &lt;name&gt; [&lt;value&gt;]</code>				
Returns	None				
Arguments	<table border="1"> <tr> <td>name</td> <td>The name whose value is being set</td> </tr> <tr> <td>value</td> <td>The value of the &lt;name&gt; argument</td> </tr> </table>	name	The name whose value is being set	value	The value of the <name> argument
name	The name whose value is being set				
value	The value of the <name> argument				
Example	<code>set_module_assignment embedded.sw.CMacro.colorSpace CMYK</code>				

**get\_files**

This command returns a list of all the files that have been added to the module.

<b>get_files</b>	
Callback availability	Main, validation, elaboration, generation, and editor
Usage	<code>get_files</code>
Returns	List of strings
Arguments	None
Example	<code>set list_of_files [get_files]</code>

## add\_file

This command adds a synthesis, simulation, or TimeQuest constraints file to the module. Files added in the main program cannot be removed. Adding files in the generation callback allows the included files to be a function of the parameter set or to be a result of generation. Files added in callbacks are in addition to any files added in the main program.

add_file		
Callback availability	Main and generation	
Usage	<code>add_file filename [<i>&lt;fileProperties&gt;</i>...]</code>	
Returns	String	
Arguments	filename	The file name to be added, relative to the directory containing the <code>_hw.tcl</code> file
	fileProperties	Files support the following 3 properties: <ul style="list-style-type: none"> <li>■ SIMULATION—File for simulation</li> <li>■ SYNTHESIS—File for synthesis</li> <li>■ SDC—TimeQuest constraints (SDC behaves like a synthesis file)</li> </ul>
Example	<code>add_file my_component.v {SIMULATION SYNTHESIS}</code>	

## add\_documentation\_link

This command allows you to add multiple documentation links for a single component.

add_documentation_link		
Callback availability	Main	
Usage	<code>add_documentation_link filename &lt;docType&gt; &lt;title&gt; &lt;fileOrUrl&gt;</code>	
Returns	None	
Arguments	docType	One of the following document types: USER_GUIDE, RELEASE_NOTES, WEBLINK, ERRATA, DATASHEET, REFERENCE_MANUAL, WAVEFORM, SCHEMATICS, TUTORIAL, OTHER
	title	The title of the document for use on menus and buttons.
	fileOrUrl	A path to the component documentation, using a syntax that provides the entire URL, not a relative path. For example: <code>http://www.mydomain.com/my_memory_controller.html</code> or <code>file:///datasheet.txt</code> .
Example	<code>add_documentation_link USER_GUIDE "Avalon Verification IP Suite User Guide" http://www.altera.com/literature/ug/ug_avalon_verification_ip.pdf</code>	

## get\_file\_properties

This command returns the list of all properties that have been defined for a file.

<b>get_file_properties</b>	
Callback availability	Main, validation, elaboration, generation, and editor
Usage	<code>get_file_properties</code>
Returns	List of strings
Arguments	None
Example	<code>get_file_properties</code>

## get\_file\_property

This command returns the value of a single file property. The file name passed as an argument may be a partial as long as it is unique. For example, if the full file name is `/components/my_file.v`, `my_file.v` is sufficient.

<b>get_file_property</b>		
Callback availability	Main, validation, elaboration, generation, and editor	
Usage	<code>get_file_property &lt;filename&gt; &lt;propertyName&gt;</code>	
Returns	Boolean	
Arguments	<code>filename</code>	The file name whose properties are being retrieved
	<code>propertyName</code>	The file name property whose value is being retrieved
Example	<code>set forSynthesis [get_file_property my_file.v SYNTHESIS]</code>	

## set\_file\_property

This command sets the value of a single file property. The file name passed to the function can be a partial file name as long as it is unique. For example, if the full file name is `/components/my_file.v`, `my_file.v` is sufficient. The available properties are described in the `add_files` command.

<b>set_file_property</b>		
Callback availability	Main, elaboration, and generation	
Usage	<code>set_file_property &lt;filename&gt; &lt;propertyName&gt; &lt;propertyValue&gt;</code>	
Returns	Boolean	
Arguments	<code>filename</code>	The file name whose properties are being retrieved
	<code>propertyName</code>	Name of the file property whose value is being retrieved
	<code>propertyValue</code>	Value to set for the file property
Example	<code>set_file_property my_file.v SYNTHESIS true</code>	

## send\_message

This command sends a message to the user of the component. The message text is normally interpreted as HTML. The `<b>` element can be used to provide emphasis. If you do not want the message text to be interpreted as HTML then pass a list like `{ info text }` as the message level.

send_message		
Callback availability	Main, validation, elaboration, generation, and editor	
Usage	<code>send_message &lt;messageLevel&gt; &lt;messageText&gt;</code>	
Returns	None	
Arguments	messageLevel	The following 4 message levels are supported: <ul style="list-style-type: none"> <li>■ <b>Error</b>—provides an error message. The SOPC Builder system cannot be generated while there are error messages.</li> <li>■ <b>Warning</b>—provides a warning message.</li> <li>■ <b>Info</b>—provides an informational message.</li> <li>■ <b>Debug</b>—provides messages when debug mode is enabled.</li> </ul>
	messageText	The text of the message
Example	<code>send_message Error "&lt;b&gt;param1&lt;/b&gt; must be greater than param2."</code>	

## Parameters

Parameters allow users of your component to affect its operation in the same manner as Verilog HDL parameters or VHDL generics.

### add\_parameter

This command adds a parameter to your component. Most of the parameter types are self-explanatory because they are used in the C programming language or HDL. However, the `string_list` and `integer_list` parameters that are used to create tables in GUIs require some explanation.

- When you use the `add_parameter` command with a `string_list` or `integer_list` parameter type, the parameter you define is displayed in a variable-sized table that includes **add** and **remove** buttons.

- If you define multiple parameters of type `string_list` or `integer_list`, you can also use the `add_display_item` command to specify that parameters should each be displayed as a column in a table, each parameter of type `string_list` or `integer_list` becomes a column in the table. [Example 7-12](#) illustrates the use of the `integer_list` parameter types to create a multi-column table.

### Example 7-12. Creating Tables Using the `string_list` and `integer_list` Parameter Types

```
add_parameter bitsWide INTEGER
add_parameter divider INTEGER
add_parameter coefficients INTEGER_LIST
add_parameter positions INTEGER_LIST
add_display_item myTable coefficients TABLE
add_display_item myTable positions TABLE
```

<b>add_parameter</b>		
Callback availability	Main program	
Usage	<code>add_parameter &lt;parameterName&gt; &lt;parameterType&gt; [&lt;defaultValue&gt; &lt;description&gt;]</code>	
Returns	String	
Arguments	<code>parameterName</code>	A name that you, the component author, choose for your parameter
	<code>parameterType</code>	The following types are supported: Integer, Natural, Positive, Boolean, Std_logic, Std_logic_vector, String, String_list, and Integer_list.
	<code>defaultValue</code>	The default length of the parameter is derived from its range.
	<code>description</code>	Explains the use of the parameter
Example	<code>add_parameter seed integer 17 "The seed to use for data generation."</code>	

### **get\_parameters**

This command returns the names of all parameters that have been previously defined by `add_parameter` as a space separated list.

<b>get_parameters</b>	
Callback availability	Main, validation, elaboration, generation, and editor
Usage	<code>get_parameters</code>
Returns	List of strings
Arguments	None
Example	<code>set parameter_summary [get_parameters]</code>



## get\_parameter\_properties

This command returns a list of all the available parameter properties as a list of strings. The `get_parameter_property` and `set_parameter_property` commands are used to get and set the values of these properties, respectively.

get_parameter_properties	
Callback availability	Main, validation, elaboration, generation, and editor
Usage	<code>get_parameter_properties</code>
Returns	List of strings
Arguments	None
Example	<code>set property_summary [get_parameter_properties]</code>

Table 7-4 describes the properties available to describe the behaviors of each of the parameters you can specify, their use, and when they can be set.

**Table 7-4. Parameter Properties (Part 1 of 3)**

Property Name	Type/Default	Can Be Set	Description
<code>AFFECTS_ELABORATION</code> (1)	Boolean, refer to description	Main program	Set <code>AFFECTS_ELABORATION</code> to <code>false</code> for parameters that do not affect the external interface of the module. An example of a parameter that does not affect the external interface is <code>isNonVolatileStorage</code> . An example of a parameter that does affect the external interface is <code>width</code> . When the value of a parameter changes, if that parameter has set <code>AFFECTS_ELABORATION=false</code> , the elaboration phase (calling the callback or hardware analysis) is not repeated, improving performance. Because the default value of <code>AFFECTS_ELABORATION</code> is <code>true</code> , the provided HDL file is normally re-analyzed to determine the new port widths and configuration every time a parameter changes.
<code>AFFECTS_GENERATION</code>	Boolean, refer to DESCRIPTION	Main program	The default value of <code>AFFECTS_GENERATION</code> is <code>false</code> if you provide a top-level HDL module, it is <code>true</code> if you provide a custom generation callback. Set <code>AFFECTS_GENERATION</code> to <code>false</code> if the value of a parameter does not change the results of system generation.

Table 7-4. Parameter Properties (Part 2 of 3)

Property Name	Type/Default	Can Be Set	Description
ALLOWED_RANGES	String, ""	Main program	Indicates the range or ranges that the parameter value can have. For integers, The <code>ALLOWED_RANGES</code> property is a list of ranges that the parameter can take on, where each range is a single value, or a range of values defined by a start and end value separated by a colon, such as 11:15. This property can also specify legal values and display strings for integers, such as {0:None 1:Monophonic 2:Stereo 4:Quadrophonic} meaning 0,1,2,4 are the legal values. You can also assign longer strings to be displayed in the GUI to string variables. For example, <code>ALLOWED_RANGES {"dev1:Cyclone IV GX" "dev2:Stratix V GT" }</code> Refer to <a href="#">Example 7-7 on page 7-8</a> and <a href="#">Figure 7-1 on page 7-8</a> for additional examples illustrating the use of this property.
DERIVED	Boolean/ false	Main program	When <code>true</code> , indicates that the parameter value does not need to be stored, typically because it is set from the validation callback. The default value is <code>false</code> .
DESCRIPTION	String, ""	Main program	A user-visible description of the parameter.
DISPLAY_HINT	String, ""	Main program	Provides a hint about how to display a property. The following values are possible: <ul style="list-style-type: none"> <li>■ <code>boolean</code>—for integer parameters whose value can be 0 or 1. The parameter displays as a checkbox.</li> <li>■ <code>radio</code>—displays a parameter with a list of values as radio buttons instead of a drop-down list.</li> <li>■ <code>hexadecimal</code>—for integer parameters, display and interpret the value as a hexadecimal number, for example: <code>0x00000010</code> instead of 16.</li> <li>■ <code>fixed_size</code>—for <code>string_list</code> and <code>integer_list</code> parameters, the <code>fixed_size DISPLAY_HINT</code> eliminates the <b>add</b> and <b>remove</b> buttons from tables.</li> </ul> Refer to <a href="#">Example 7-7 on page 7-8</a> and <a href="#">Figure 7-1 on page 7-8</a> for examples illustrating the use of this property.
DISPLAY_NAME	String, ""	Main program	This is the GUI label that appears to the left of the parameter.
DISPLAY_UNITS	String, ""	Main program	This is the GUI label that appears to the right of the parameter.
ENABLED	Boolean, <code>true</code>	Main program, validation, and elaboration, callbacks	When <code>false</code> , the parameter is disabled, meaning that it is displayed, but greyed out, indicating that it is not editable on the parameterization GUI.
HDL_PARAMETER	Boolean, false	Main program	When <code>true</code> , the parameter must be passed to the HDL component description. The default value is <code>false</code> .

**Table 7-4. Parameter Properties (Part 3 of 3)**

Property Name	Type/Default	Can Be Set	Description
NEW_INSTANCE_VALUE	String, ""	Main program	This property allows you to change the default value of a parameter without affecting older components that have assigned a default value to this parameter using the <code>defaultValue</code> argument. The practical result is that older components will continue to use <code>defaultValue</code> for the parameter and newer components can use the value assigned by <code>NEW_INSTANCE_VALUE</code> .
SYSTEM_INFO	String, ""	Main program	Allows you to assign information about the instantiating system to a parameter that you define. <code>SYSTEM_INFO</code> requires a keyword argument specifying the type of information requested, <code>&lt;info-type&gt;</code> . <code>&lt;info-type&gt;</code> may also take an argument. The syntax of the Tcl command is:  <pre>set_parameter_property my_parameter SYSTEM_INFO &lt;info-type&gt; [arg]</pre> The following values for <code>&lt;info-type&gt;</code> are predefined: <ul style="list-style-type: none"> <li>■ CLOCK_RATE</li> <li>■ CLOCK_DOMAIN</li> <li>■ RESET_DOMAIN</li> <li>■ ADDRESS_WIDTH</li> <li>■ ADDRESS_MAP</li> <li>■ MAX_SLAVE_DATA_WIDTH</li> <li>■ INTERRUPTS_USED</li> <li>■ DEVICE_FAMILY</li> <li>■ DEVICE_FEATURES</li> </ul>
UNITS	String, ""	Main program	Sets the units of the parameter. The following values are possible: picoseconds, nanoseconds, microseconds, milliseconds, seconds, hertz, kilohertz, megahertz, gigahertz, address, bits, bytes, kilobytes, megabytes, gigabytes, bitspersecond, kilobitspersecond, megabitspersecond, gigabitspersecond. For example, <code>set_parameter_property frequency UNITS gigahertz</code>
VISIBLE	Boolean, true	Main program, validation, and elaboration, callbacks	Indicates whether or not to display the parameter in the parameterization GUI.

**Note to Table 7-4:**

(1) The `AFFECTS_ELABORATION` property was called `AFFECTS_PORT_WIDTHS` before version 9.0 of the Quartus II software.

Table 7-5 lists the properties that you can use with the `system_info` parameter property.

**Table 7-5. SYSTEM\_INFO Properties (Part 1 of 2)**

Property	Type	Description
ADDRESS_MAP	String	Assigns an XML formatted string describing the address map to the parameter you specify.  <code>set_parameter_property &lt;my_parameter&gt; SYSTEM_INFO {ADDRESS_MAP &lt;my_avalon-mm_master&gt;}</code>
ADDRESS_WIDTH	Integer	Assigns an integer to the parameter that you specify that is the number of bits an Avalon-MM master must drive to address all of its slaves, using byte addresses.  <code>set_parameter_property &lt;my_parameter&gt; SYSTEM_INFO {ADDRESS_WIDTH &lt;my_avalon-mm_master&gt;}</code>
CLOCK_DOMAIN	Integer	Assigns an integer representing the clock domain to the parameter you specify. You can use this command to determine whether multiple interfaces in your module are on the same clock domain. The absolute value of the integer value is arbitrary, but if two interfaces are on the same clock domain, the <code>CLOCK_DOMAIN</code> value is guaranteed to be the same and greater than zero.  <code>set_parameter_property &lt;my_parameter&gt; SYSTEM_INFO {CLOCK_DOMAIN &lt;my_clk&gt;}</code>
CLOCK_RATE	Integer or String	Assigns a positive number which is the clock frequency in Hz to the clock input interface you specify. Assigns 0 if the clock rate is not known.  <code>set_parameter_property &lt;my_parameter&gt; SYSTEM_INFO {CLOCK_RATE &lt;my_clk&gt;}</code>
DEVICE_FAMILY	String	Assigns the family name (not the specific device part number) of the currently selected device to the parameter you specify.  <code>set_parameter_property &lt;my_parameter&gt; SYSTEM_INFO {DEVICE_FAMILY}</code>
DEVICE_FEATURES	String	Creates a list of key/value pairs delineated by spaces indicating whether a particular device feature is available in the currently selected device family. The format of the list is suitable for passing to the Tcl array <code>set</code> command. This list is assigned to the parameter you specify. The following features are supported: <code>M512_MEMORY</code> , <code>M4K_MEMORY</code> , <code>M9K_MEMORY</code> , <code>M144K_MEMORY</code> , <code>MRAM_MEMORY</code> , <code>MLAB_MEMORY</code> , <code>ESB</code> , <code>DSP</code> , and <code>EMUL</code> .  <code>set_parameter_property &lt;my_parameter&gt; SYSTEM_INFO {DEVICE_FEATURES}</code>
INTERRUPTS_USED	Integer or string	Creates a mask indicating which bits of the interrupt receiver vector are connected to an interrupt sender. This mask is assigned to the parameter you specify. You can use this interrupt mask to optimize logic that handles interrupts.  <code>set_parameter_property &lt;my_parameter&gt; SYSTEM_INFO {INTERRUPTS_USED &lt;my_interrupt_receiver&gt;}</code>

**Table 7-5. SYSTEM\_INFO Properties (Part 2 of 2)**

Property	Type	Description
MAX_SLAVE_DATA_WIDTH	Integer	Assigns an integer to the parameter you specify that is the data width of the widest slave connected to the specified Avalon-MM master.  set_parameter_property <my_parameter> SYSTEM_INFO {MAX_SLAVE_DATA_WIDTH <my_avalon_mm_master>}
RESET_DOMAIN	Integer	Assigns an integer representing the reset domain to the parameter you specify. You can use this command to determine whether multiple interfaces in your module are on the same reset domain. The absolute value of the integer value is arbitrary, but if two interfaces are on the same reset domain, the RESET_DOMAIN value is guaranteed to be the same and greater than zero.  set_parameter_property <my_parameter> SYSTEM_INFO {RESET_DOMAIN <my_reset>}

### get\_parameter\_property

This command returns a single parameter property.

get_parameter_property		
Callback availability	Main, validation, elaboration, generation, and editor	
Usage	get_parameter_property <parameterName> <propertyName>	
Returns	string, boolean, or units depending on property refer to <a href="#">Table 7-4 on page 7-23</a>	
Arguments	parameterName	The name of the parameter whose property value is being retrieved
	propertyName	One of the properties listed in <a href="#">Table 7-4 on page 7-23</a>
Example	get_parameter_property parameter1 GROUP	

### set\_parameter\_property

This command sets a single parameter property.

set_parameter_property		
Callback availability	Main, validation, and elaboration	
Usage	set_parameter_property <parameterName> <propertyName> <value>	
Returns	string, boolean, or units depending on property	
Arguments	parameterName	Specifies the parameter that is being set
	propertyName	Specifies the property of parameterName that is being set, refer to <a href="#">Table 7-4 on page 7-23</a> for a list of properties
	value	Provides the values
Example	set_parameter_property BAUD_RATE ALLOWED_RANGES {9600 19200 38400}	

## get\_parameter\_value

This command returns the current value of a parameter defined previously with the `add_parameter` command.

get_parameter_value	
Callback availability	Validation, elaboration (1), compose. generation, and editor
Usage	<code>get_parameter_value &lt;parameterName&gt;</code>
Returns	String
Arguments	<code>parameterName</code> Specifies the parameter that is being retrieved
Example	<code>set fifo_width [get_parameter_value fifo_width]</code>

**Note:**

- (1) If `AFFECTS_ELABORATION=false` for a given parameter, `get_parameter_value` is not available for that parameter from the elaboration callback. If `affects_generation=false` then it is not available from the generation callback.

## set\_parameter\_value

This command sets a parameter value. The values of derived parameters can be set from the validation and elaboration callbacks. The values of parameters which are not marked as derived or `system_info` can be set from the editor callback.

set_parameter_value	
Callback availability	Validation, elaboration, and editor
Usage	<code>set_parameter_value &lt;parameterName&gt; &lt;value&gt;</code>
Returns	None
Arguments	<code>parameterName</code> Specifies the parameter that is being set
	<code>value</code> Specifies the value of <code>parameterName</code>
Example	<code>set_parameter_value BAUD_RATE 19200</code>

## decode\_address\_map

This is a utility function to convert an XML-formatted address map into a list of Tcl lists. Each inner list is in the correct format for conversion to an array. The XML code describing each slave includes: its name, start address, and end address + 1. [Figure 7-2](#) shows a portion of an SOPC Builder system with three Avalon-MM slave devices.

**Figure 7-2. SOPC Builder System with Three Avalon-MM Slaves**

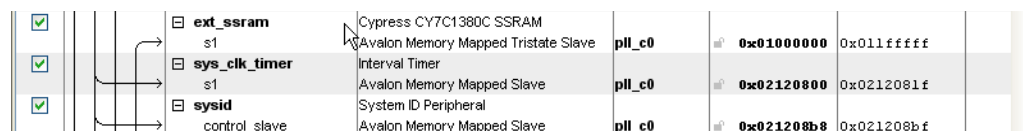

<input checked="" type="checkbox"/>	ext_ssram s1	Cypress CY7C1380C SSRAM Avalon Memory Mapped Tristate Slave	pll_c0	0x01000000	0x011fffff
<input checked="" type="checkbox"/>	sys_clk_timer s1	Interval Timer Avalon Memory Mapped Slave	pll_c0	0x02120800	0x0212081f
<input checked="" type="checkbox"/>	sysid control_slave	System ID Peripheral Avalon Memory Mapped Slave	pll_c0	0x021208b8	0x021208bf

**Example 7-13** shows the XML that describes the address map for the Avalon-MM master that accesses these slaves. The format of the XML string provided may differ from that described here, it may have different white space between the elements and could include additional attributes or elements. Using `decode_address_map` command to decode the XML representing an Avalon-MM master's address map is easier and ensures that your code will work with future versions of the XML address map.



Altera recommends that you use the code provided in the description of **Example 7-13** to enumerate over the components within an address map, rather than writing your own parser.

**Example 7-13. Address Map for an Avalon-MM Master**

```
<address-map>
  <slave name='ext_ssram' start='0x01000000' end='0x01200000' />
  <slave name='sys_clk_timer' start='0x02120800' end='0x02120820' />
  <slave name='sysid' start='0x021208B8' end='0x021208C0' />
</address-map>
```

<b>decode_address_map</b>			
Callback availability	Validation, compose. elaboration, and generation		
Usage	<code>decode_address_map &lt;address_map_XML_string&gt;</code>		
Returns	List of Tcl lists, each one suitable for passing to array set		
Arguments	<table border="1"> <tr> <td><code>address_map_XML_string</code></td> <td>An XML string describing the address map of an Avalon-MM master.</td> </tr> </table>	<code>address_map_XML_string</code>	An XML string describing the address map of an Avalon-MM master.
<code>address_map_XML_string</code>	An XML string describing the address map of an Avalon-MM master.		
Example	<pre>set address_map_xml [get_parameter_value my_map_param] set address_map_dec [decode_address_map \$address_map_xml] foreach i \$address_map_dec {   array set info \$i   send_message info "Connected to slave \$info(name)" }</pre>		

## Display Items

You specify your component GUI using the display commands.

### add\_display\_item

You can use this command to specify the following aspects of component display:

- You can create logical groups for a component's parameters. For example, you might want to create separate groups for the component's timing, size, and simulation parameters. A component displays the groups and parameters in the order that you specify the display items for them in the `_hw.tcl` file.
- You can create multi-column tables to present a component's parameters. Refer to **Example 7-12 on page 7-22** for an example that illustrates multi-column tables.
- You can specify an image to provide a pictorial representation of a parameter or parameter group.

- You can create a button by adding a display item of type `action`. The display item includes the name of the callback to run when the action is performed.

You create a display group by adding display items to it.

<b>add_display_item</b>		
Callback availability	Main program	
Usage	<code>add_display_item &lt;groupName&gt; &lt;id&gt; &lt;type&gt; [&lt;additionalInfo&gt;]</code>	
Returns	String	
Arguments	<code>groupName</code>	Specifies the group to which a display item belongs.
	<code>id</code>	Specifies the parameter or icon to be displayed in a group. Each display item associated with a component must have a different ID.
	<code>type</code>	Specifies the category of the display item. The following types are defined: <ul style="list-style-type: none"> <li>■ <code>icon</code>—a <code>.gif</code>, <code>.jpg</code>, or <code>.png</code> file</li> <li>■ <code>parameter</code>—a parameter in the instance</li> <li>■ <code>text</code>—a block of text</li> <li>■ <code>group</code>—a group. If the <code>groupName</code> is also defined, the new group is a child of the <code>groupName</code> group. If <code>groupName</code> is an empty string, the group is top-level.</li> <li>■ <code>action</code>—an action defined by a callback procedure when you click the button labeled by <code>actionName</code>.</li> </ul>
	<code>additionalInfo</code>	Provides extra information required for display items. The following examples illustrate how you use the <code>additionalInfo</code> argument for the various types: <ul style="list-style-type: none"> <li>■ <code>add_display_item groupName id icon path-to-image-file</code></li> <li>■ <code>add_display_item groupName parameterName parameter (additionalInfo not required)</code></li> <li>■ <code>add_display_item groupName id text "your-text"</code> The <code>your-text</code> argument is a block of text that is displayed in the GUI. Some simple HTML formatting is allowed, such as <code>&lt;b&gt;</code> and <code>&lt;i&gt;</code>, if the text starts with <code>"html&gt;</code>.</li> <li>■ <code>add_display_item parentGroupName childGroupName group [tab]</code> The <code>tab</code> is an optional parameter. If present, the group appears in separate tab in the GUI for the instance.</li> <li>■ <code>add_display_item parentGroupName actionName action buttonClickCallbackProc</code></li> </ul>
Examples	<pre>add_display_item timing read_latency parameter add_display_item sound speaker icon speaker.jpg</pre>	



## GET\_DISPLAY\_ITEMS

This command returns a list of all items to be displayed as part of the parameterization GUI.

<b>get_display_items</b>	
Callback availability	Main, elaboration, generation, and editor
Usage	<code>get_display_items</code>
Returns	List of strings
Arguments	None
Example	<code>get_display_items</code>

## GET\_DISPLAY\_ITEM\_properties

This command returns a list of names of the properties of display items that are part of the parameterization GUI.

<b>get_display_item_properties</b>	
Callback availability	Main
Usage	<code>get_display_item_properties</code>
Returns	List of strings
Arguments	None
Example	<code>get_display_item_properties</code>

## GET\_DISPLAY\_ITEM\_property

This command returns the value of specific property of a display item that is part of the parameterization GUI.

<b>get_display_item_property</b>		
Callback availability	Main	
Usage	<code>get_display_item_property &lt;itemName&gt; &lt;propertyName&gt;</code>	
Returns	String	
Arguments	<code>itemName</code>	The item whose property value is being retrieved
	<code>propertyName</code>	The property whose value is being retrieved
Example	<code>set my_label [ get_display_item_property my_action DISPLAY_NAME ]</code>	

**set\_DISPLAY\_ITEM\_property**

This command sets the value of specific property of a display item that is part of the parameterization GUI.

<b>set_display_item_property</b>		
Callback availability	Main	
Usage	<code>set_display_item_property &lt;itemName&gt; &lt;propertyName&gt; &lt;value&gt;</code>	
Returns	String	
Arguments	<code>itemName</code>	The item whose property value is being set
	<code>propertyName</code>	The property whose value is being set
	<code>value</code>	The value to set
Example	<pre>set_display_item_property my_action DISPLAY_NAME "Click Me" set_display_item_property my_action DESCRIPTION "clicking this button runs the click_me_callback proc in the hw.tcl file"</pre>	

**Interfaces and Ports**

You can use the interface and port commands to define interfaces and ports and retrieve their properties.

**add\_interface**

This command adds an interface to your module. As the component author, you choose the name of the interface. By default, interfaces are enabled. You can set the interface property `ENABLED` to `false`, to disable a component interface. If an interface is disabled, it is hidden and its ports are automatically terminated to their default values. Signals that you designate as active low by appending a `_n` are terminated to 1. All other signals are terminated to 0.

 The properties available for each interface type are different. The common properties, `ENABLED` and `ASSOCIATED_CLOCK` apply to all interface types. Refer to the *Avalon Interface Specifications* for a description of other properties.

<b>add_interface</b>		
Callback availability	Main program, and elaboration	
Usage	<code>add_interface &lt;interfaceName&gt; &lt;interfaceType&gt; &lt;direction&gt; [&lt;associatedClock&gt;] (1)</code>	
Returns	String	
Arguments	<code>interfaceName</code>	A name that you choose to identify an interface.
	<code>interfaceType</code> and <code>direction</code>	There are 7 <code>interfaceTypes</code> . The following directions are possible for these <code>interfaceTypes</code> : Interface TypeDirection avalonmaster, slave (2) avalon_tristateslave avalon_streamingsource, sink interruptsender, receiver conduitend clocksource, sink nios_custom_instructionslave
	<code>associatedClock</code>	This defines the clock associated with the interface. It is required for all interfaces except clock interfaces.
Example	<code>add_interface mm_slave avalon slave clock0</code>	

**Notes:**

- (1) For interfaces that are not associated with clocks, such as clock interfaces themselves, the `associatedClock` is omitted. Another option is to specify the `associatedClock` argument as `asynchronous`.
- (2) The terms *master*, *source*, and *start* are interchangeable. The terms *slave*, *sink*, and *end* are interchangeable.

### get\_interfaces

This command returns the names of all interfaces that have been previously defined by `add_interface` as a space separated list.

<b>get_interfaces</b>	
Callback availability	Main, validation, elaboration, generation, and editor
Usage	<code>get_interfaces</code>
Returns	List of strings
Arguments	None
Example	<code>set all_interfaces [get_interfaces]</code>

## get\_interface\_properties

This command returns the names of all the available interface properties for the specified interface as a space separated list.

get_interface_properties	
Callback availability	Main program, validation, elaborations, and editor
Usage	get_interface_properties <interfaceName>
Returns	List of strings
Arguments	interfaceName      The name of an interface that you defined
Example	get_interface_properties mm_slave

 The properties available for each interface type are different. Refer to the *Avalon Interface Specifications* for more information about interface properties.

The interface properties that are common to all interface types are listed below in [Table 7-6](#).

**Table 7-6. Interface Properties Common to All Interface Types**

Property	Type	Description
ASSOCIATED_CLOCK	String	The name of the clock interface that this interface is synchronous to.
ENABLED	Boolean	Specifies whether or not interface is enabled.

## get\_interface\_property

This command returns the value of a single interface property from the specified interface.

get_interface_property	
Callback availability	Main program, and elaboration
Usage	get_interface_property <interfaceName> <propertyName>
Returns	string, boolean, or units depending on property Refer to the <i>Avalon Interface Specifications</i> for more information about interface properties
Arguments	interfaceName      The name of an interface from which you want to retrieve information
	propertyName      The name of the property whose value you want to retrieve. This property is either ENABLED or ASSOCIATED_CLOCK or a property name defined by the interface.
Example	get_interface_property mm_slave readWaitTime

## set\_interface\_property

This command sets a single interface property for an interface.

set_interface_property		
Callback availability	Main and elaboration	
Usage	set_interface_property <interfaceName> <propertyName> <value>	
Returns	String	
Arguments	interfaceName	The name of an interface that includes this property
	propertyName	The name of the property whose value you want to set, which is ENABLED or ASSOCIATED_CLK or a name from the <i>Avalon Interface Specifications</i> .
	value	The value to set for the specified property
Example	set_interface_property mm_slave linewidthBursts false	

## add\_interface\_port

This command adds a port to an interface on your module. As the component author, you determine the name of the port. The port width and direction must be set by the end of the elaboration phase. The port width can be set with one of the following mechanisms:

- A constant width or a width expression can be set in the main program
- A constant width can be set in the elaboration callback



Without an elaboration callback, for static components quartus\_map determines the port width from the HDL

add_interface_port		
Callback availability	Main program and elaboration	
Usage	add_interface_port <interfaceName> <portName> <portRole> [<direction> <width_expr>]	
Returns	String	
Arguments	interfaceName	The name of the interface to which the port belongs.
	portName	The name of the port that you, the component author, have chosen.
	portRole	The role of this port within the interfaces. Port roles are referred to as signal types in the <i>Avalon Interface Specification</i> . Refer to the <i>Avalon Interface Specifications</i> for the signal types available for each interface type.
	direction	The direction can be input, output, or bidir
	width_expr	The port's width expression. In simple cases, this is just the width of the port in bits.
Example	add_interface_port mm_slave s0_rdata readdata output 32	

## get\_interface\_ports

This command returns the names of all of the ports that have been added to a given interface. If the interface name is omitted, all ports for all interfaces are returned.

get_interface_ports	
Callback availability	Main, validation, elaboration, generation, and editor
Usage	<code>get_interface_ports [&lt;interfaceName&gt;]</code>
Returns	String
Arguments	<code>interfaceName</code> The name of the interface whose ports you want to list. (Optional)
Example	<code>get_interface_ports mm_slave</code>

## get\_port\_properties

This command returns a list of all available port properties.

get_port_properties	
Callback availability	Main, validation, elaboration, generation, and editor
Usage	<code>get_port_properties &lt;portName&gt;</code>
Returns	String, boolean, or units depending on property refer to <a href="#">Table 7-4 on page 7-23</a>
Arguments	<p>The name of the port whose properties are required. The following 7 port properties are supported:</p> <ul style="list-style-type: none"> <li>■ <code>direction</code></li> <li>■ <code>termination</code></li> <li>■ <code>termination_value</code></li> <li>■ <code>vhdl_type</code></li> <li>■ <code>width</code></li> <li>■ <code>width_expr</code></li> </ul> <p>Refer to <a href="#">Table 7-7</a> for a description of these properties.</p>
Example	<code>get_port_properties mm_slave</code>

[Table 7-7](#) describes the available port properties

**Table 7-7. Port Properties (Part 1 of 2)**

Name	Type	Description
<code>direction</code>	<code>input, output, bidir</code>	The direction of the port from the component's perspective.
<code>termination</code>	<code>boolean</code>	When <code>true</code> , instead of connecting the port to the SOPC Builder system, it is left unconnected for <code>OUTPUT</code> and <code>BIDIR</code> or set to a fixed value for <code>INPUT</code> . Has no effect for components that implement a generation callback instead of using the default wrapper generation.
<code>termination_value</code>	<code>integer</code>	The constant value to drive an input port.

**Table 7-7. Port Properties (Part 2 of 2)**

Name	Type	Description
vhdl_type	std_logic std_logic_vector auto	indicates the type of a VHDL port. The default value, auto, selects std_logic if the width is fixed at 1, and std_logic_vector otherwise.
width	integer	The width of the port in bits.
width_expr	string	The width expression of a port. Setting the width and width_expr properties have the same effect; they both update the effective width expression. The width/width_expr properties can be set to an integer at any time. They can only be set to arithmetic expressions in the main program.  The values of the width and width_expr properties behave differently when get_port_property is used. width always returns the current integer width of the port. width_expr always returns the unevaluated width expression.

### get\_port\_property

This command returns the value of single port property for the specified port.

get_port_property		
Callback availability	Main, validation, elaboration, generation, and editor	
Usage	get_port_property <portName> <propertyName>	
Returns	Depends on the type of the property	
Arguments	portName	The name of the port
	propertyName	One of the supported properties described in <a href="#">Table 7-7</a> .
Example	get_port_property rdata WIDTH	

### set\_port\_property

This command sets a single port property.

set_port_property		
Callback availability	Main program, elaboration, and generation	
Usage	set_port_property <portName> <propertyName> [ <i>&lt;value&gt;</i> ]	
Returns	String, boolean, or units depending on property refer to <a href="#">Table 7-4 on page 7-23</a>	
Arguments	portName	The name of the port
	propertyName	One of the supported properties described in <a href="#">Table 7-7</a> .
	value	The value to set
Example	set_port_property rdata WIDTH 32	

### get\_interface\_assignments

This command returns the value of all interface assignments for the specified interface.

get_interface_assignments	
Callback availability	Main, validation, and elaboration
Usage	get_interface_assignments <interfaceName>
Returns	String
Arguments	interfaceName      The name of the Avalon interface whose assignment is being retrieved
Example	get_interface_assignments s1

### get\_interface\_assignment

This command returns the value of the specified name for the specified interface.

get_interface_assignment	
Callback availability	Main, validation, and elaboration
Usage	get_interface_assignments <interfaceName> <name>
Returns	String
Arguments	interfaceName      The name of the Avalon interface whose assignment is being retrieved name                  The assignment whose value is being retrieved
Example	get_interface_assignment s1 embeddedsw.configuration.isFlash

### set\_interface\_assignment

This command sets the value of the specified assignment for the specified interface.

set_interface_assignment	
Callback availability	Main, validation, and elaboration
Usage	set_interface_assignment <interfaceName> <name> [<value>]
Returns	None
Arguments	interfaceName      The name of the Avalon interface whose assignment is being set name                  The assignment whose value is being set value                  The value to assign
Example	set_interface_assignment s1 embeddedsw.configuration.isFlash 1

## Generation

This section covers the commands that get generation properties.



## get\_generation\_properties

This command returns the names of all the available generation properties as a space separated list. These properties cannot be changed by the module. Generation properties are provided to the generation callback to support per-instance HDL generation.

get_generation_properties	
Callback availability	Main, validation, elaboration, generation, and editor
Usage	get_generation_properties
Returns	String. The following generation properties are supported: <ul style="list-style-type: none"> <li>■ hdl_language</li> <li>■ output_directory</li> <li>■ output_name</li> </ul> Refer to <a href="#">Table 7-8</a> for a description of the generation properties.
Arguments	None
Example	get_generation_properties

[Table 7-8](#) describes the generation properties.

**Table 7-8. Generation Properties**

Name	Type	Description
hdl_language	enum	The HDL language to generate. Is either <code>verilog</code> or <code>vhdl</code> (lowercase). If the module cannot generate the specified language, generating in the other language is acceptable.
output_directory	file	The location in which files must be generated. The filename components in the directory name are separated with forward slashes.
output_name	string	OUTPUT_NAME is <code>module_0</code> and the HDL_LANGUAGE is <code>verilog</code> , the file <b>module_0.v</b> or <b>module_0.sv</b> must be generated and must contain the module, <code>module_0</code> .

## get\_generation\_property

This command returns the value of a single generation property.

get_generation_property	
Callback availability	Generation
Usage	get_generation_property <propertyName>
Returns	String, boolean, or units depending on property refer to <a href="#">Table 7-4 on page 7-23</a>
Arguments	propertyName One of the 3 generation properties: <ul style="list-style-type: none"> <li>■ HDL_LANGUAGE</li> <li>■ OUTPUT_DIRECTORY</li> <li>■ OUTPUT_NAME</li> </ul>
Example	get_generation_property OUTPUT_DIRECTORY

## Deprecated Commands and Properties

Table 7-9 lists commands and properties that were available in previous versions of the Quartus II software and the command that have replaced them.

**Table 7-9. Deprecated Commands and Properties**

Deprecated Command	Replacement
add_clock_interface <name>	add_interface <name> clock input
add_port_to_clock_interface <name> <role> <interface>	add_interface_port <interface> <name> <role> 1
add_port_to_interface <interface> <name> <role>	add_interface_port <interface> <name> <role> <input> 1
get_generation_setting <property>	get_generation_property <property>
get_list_of_ports <direction>	get_interface_ports
set_module <name>	set_module_property name <name>
set_module_description <description>	set_module_property description <description>
set_port_direction_and_width <name> <direction> <width>	set_port_property <name> direction <direction>; set_port_property <name> width <width>
set_source_file <file>	set_module_property top_level_hdl_file <file>
get_project_property	To determine device family, use the following commands: In the main program:  <pre>add_parameter DEVICE_FAMILY string "unknown" set_parameter_property DEVICE_FAMILY SYSTEM_INFO device_family</pre> In the validation, generation callback read it using the following command:  <pre>get_parameter_value DEVICE_FAMILY</pre>
<b>Deprecated Module Properties</b>	
datasheet_url	use: add_documentation_link command.
libraries	Unnecessary
class_name	name
module_file_name	top_level_hdl_file
preview_<n>_callback	<n>_callback
<b>Deprecated Parameter Properties</b>	
affects_port_widths	affects_elaboration
GROUP	Use add_display_item instead
<b>Deprecated Generation Properties</b>	
language	hdl_language

This chapter identifies the files you must include when archiving an SOPC Builder project. With this information, you can archive the SOPC Builder system. You may want to archive your SOPC Builder system for one of the following reasons:

- To place an SOPC Builder design under source control
- To create a backup
- To bundle a design for transfer to another location

To use this information, you must decide what source control or archiving tool to use, and you must know how to use it. This chapter describes how to find and identify the files that you must include in an archived SOPC Builder design. Refer to “[Required Files](#)” on page 8–2.

### Limitations

This chapter provides information about archiving SOPC Builder systems, including Nios® II software applications, if any. If your SOPC Builder system does not contain a Nios II processor, you can disregard information about archiving Nios II software applications.

This chapter does not cover archiving SOPC Builder components, for two reasons:

- SOPC Builder components can be recovered, if necessary, from the original Quartus® II and Nios II installations.
- If your SOPC Builder system was developed with an earlier version of the Quartus II software and Nios II Embedded Design Suite (EDS), when you restore it for use with the current version, you normally use the current, installed components.

If your SOPC Builder system was developed with an earlier version of the Quartus II Complete Design Suite and you restore it for use with the current version, the regenerated system is functionally identical to the original system. However, there might be differences in details such as timing performance, component implementation, or HAL implementation.

 For details of version changes, refer to the [Quartus II Reference Documentation](#).

To ensure that you can regenerate your exact original design, maintain a record of the tool and IP version(s) originally used to develop the design. Retain the original installation files or media in a safe place.

The archival process addressed by this chapter is different than Quartus II project archiving. A Quartus II project archive contains the complete Quartus II project, including the SOPC Builder module. The Quartus II software adds all HDL files to the archive, including HDL files generated by SOPC Builder, although these files are not strictly necessary, if you regenerate the design files afterwards. A Quartus II project archive also archives the Quartus II IP (.qip) file.

This chapter is only concerned with archiving the SOPC Builder system, without the generated HDL files.

 For more details about archiving Quartus II projects, refer to the *Managing Quartus II Projects* chapter in volume 2 of the *Quartus II Handbook*.

## Required Files

This section describes the files required to archive an SOPC Builder system and its associated Nios II software projects (if any). This is the minimum set of files needed to completely recompile an archived system, both the SRAM Object File (.sof) and the executable software (.elf).

 If you have Nios II software projects, archive them together with the SOPC Builder system on which they are based. For more details about archiving Nios II designs, refer to the *Using the Nios II Software Build Tools* chapter of the *Nios II Software Developer's Handbook*.

The files listed in [Table 8-1](#) are located in the Quartus II project directory.

**Table 8-1. Files Required for an SOPC Builder System**

File Description	File Name	Write Permission Required? (1)
SOPC Builder design file (.sopc)	<sopc_builder_system>.sopc	Yes
SOPC Builder classic system description for generation, a peripheral template file (.ptf) (1)	<sopc_builder_system>.ptf	Yes
SOPC Builder report file, an SOPC information file (.sopcinfo)	<sopc_builder_system>.sopcinfo	Yes
All non-generated HDL source files (2)	for example: top_level_schematic.bdf, customlogic.v	No
Quartus II project file (.qpf)	<project_name>.qpf	No
Quartus II settings file (.qsf)	<project_name>.qsf	Yes

**Notes to Table 8-1:**

- (1) The <sopc\_builder\_system>.ptf file is only required if you intend to edit or view the system in a version of SOPC Builder prior to version 7.1 and must also be writable to generate a system.
- (2) Include all HDL source files not generated by SOPC Builder, including HDL source files you create or copy from elsewhere. To identify a file generated by SOPC Builder, open the file and look for the following header: Legal Notice: (C) <year> Altera Corporation. All rights reserved.

Many source control tools mark local files read-only by default. In this case, you must override this behavior. You do not have to check the files out of source control unless you are modifying the SOPC Builder design or Nios II software project.

Most systems generated with SOPC Builder require memory. For example, embedded processor systems require memory for software, while digital signal processing (DSP) systems require memory for data buffers. Many systems use multiple types of memories. For example, a processor-based DSP system can use off-chip SDRAM to store software, and on-chip RAM for fast access to data buffers. You can use SOPC Builder to integrate almost any type of memory into your system.

This chapter uses design examples to describe how to build a memory subsystem as part of a larger system created with SOPC Builder. This chapter focuses on the following kinds of memory most commonly used in SOPC Builder systems:

- “On-Chip RAM and ROM” on page 9–6
- “EPCS Serial Configuration Device” on page 9–9
- “SDR SDRAM” on page 9–11
- “DDR SDRAM” on page 9–14
- “DDR2 SDRAM” on page 9–14
- “Off-Chip SRAM and Flash Memory” on page 9–15

This chapter assumes that you are familiar with the following task and concepts:

- Creating FPGA designs and making pin assignments with the Quartus® II software. For details, refer to the *Introduction to the Quartus II Software* manual.
- Building simple systems with SOPC Builder. For details, refer to [Chapter 1, Introduction to SOPC Builder](#).
- SOPC Builder components. For details, refer to [Chapter 4, SOPC Builder Components](#).
- Basic concepts of the Avalon® interfaces. You do not need extensive knowledge of the Avalon interfaces, such as transfer types or signal timing. However, to create your own custom memory subsystem with external memories, you need to understand the Avalon Memory-Mapped (Avalon-MM) interface. For details, refer to [Chapter 2, System Interconnect Fabric for Memory-Mapped Interfaces](#) and the *Avalon Interface Specifications*.

 Refer to the *Memory System Design* chapter in the *Embedded Design Handbook* for additional information on the efficient use of memories in SOPC Builder systems.

## Example Design

This chapter demonstrates the process for building a system that contains one of each type of memory as shown in [Figure 9–1](#). Each section of the chapter builds on previous sections, culminating in a complete system.

By following the example design in this chapter, you learn how to create a complete customized memory subsystem for your system or design. The memory components in the example design are independent. For a custom system, you only need to instantiate the memories you need. You can also create multiple instantiations of the same type of memory, limited only by on-chip memory resources or FPGA pins to interface with off-chip memory devices.

### Example Design Structure

Figure 9-1 shows a block diagram of the example system.

Figure 9-1. Example Design Block Diagram

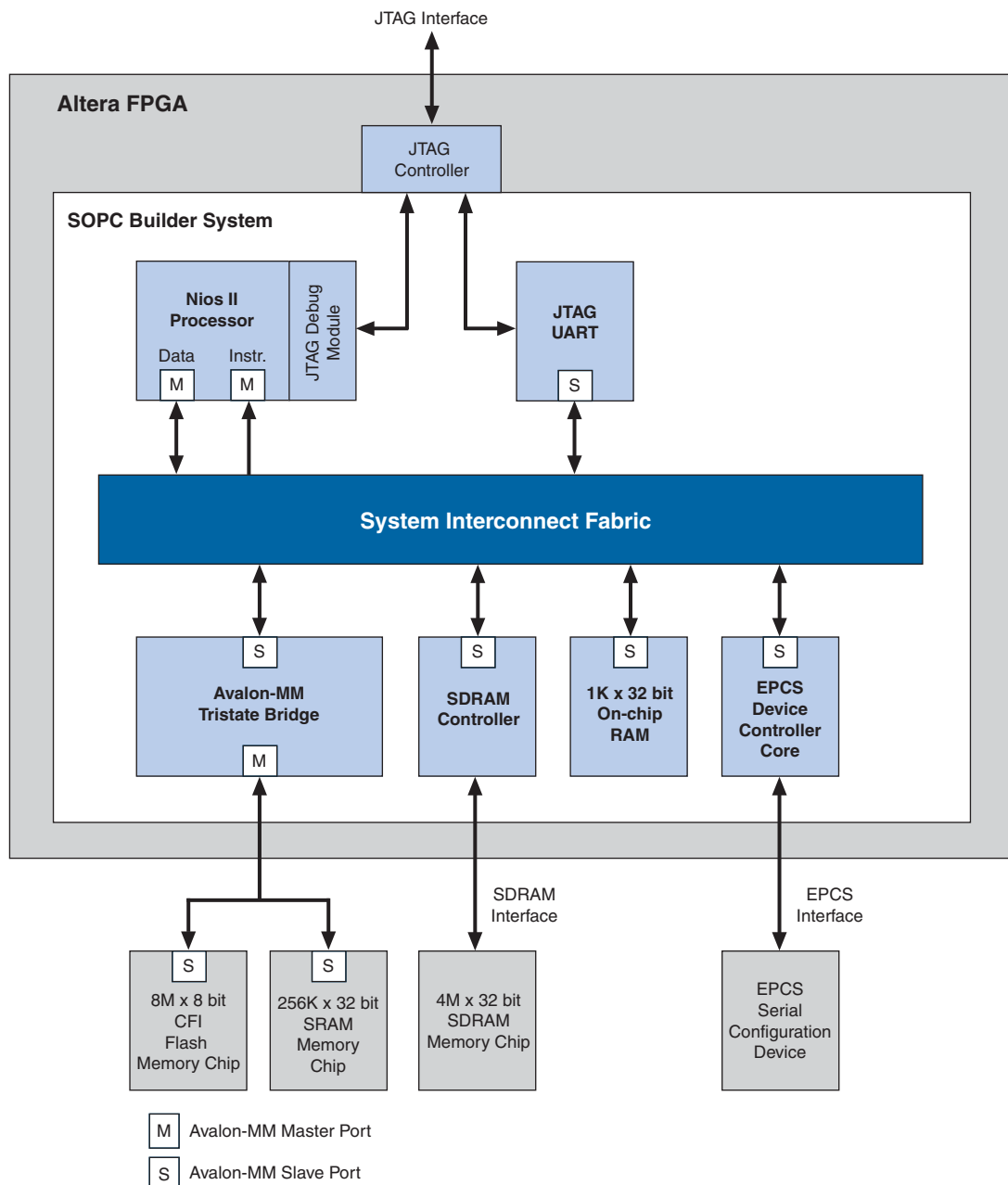

In [Figure 9-1](#), all blocks shown below the system interconnect fabric comprise the memory subsystem. For demonstration purposes, this system uses a Nios® II processor core to master the memory devices, and a JTAG UART core to communicate with the host PC. However, the memory subsystem could be connected to any master component, located either on-chip or off-chip.

## Example Design Starting Point

The example design consists of the following elements:

- A Quartus II project named **quartus2\_project**. A Block Design File (.bdf) named **toplevel\_design**. **toplevel\_design** is the top-level design file for **quartus2\_project**. **toplevel\_design** instantiates the SOPC Builder system, as well as other pins and modules required to complete the design.
- An SOPC Builder system named **sopc\_memory\_system**. **sopc\_memory\_system** is a subdesign of **toplevel\_design**. **sopc\_memory\_system** instantiates the memory components and other SOPC Builder components required for a functioning SOPC Builder system.

This discussion assumes that the **quartus2\_project** already exists, **sopc\_memory\_system** has been started in SOPC Builder, and the Nios II core and the JTAG UART core are already instantiated. This example design uses the default settings for the Nios II core and the JTAG UART core; these settings do not affect the rest of the memory subsystem.

## Hardware and Software Requirements

To build a memory subsystem similar to the example design in this chapter, you need the following tools:

- Quartus II software version 5.0 or higher—Both Quartus II Web Edition and the fully licensed version support this design flow.
- Nios II Embedded Design Suite (EDS) version 5.0 or higher—Both the evaluation edition and the fully licensed version support this design flow. The Nios II EDS provides the SOPC Builder memory components described in this chapter. It also provides several complete example designs which demonstrate a variety of memory components instantiated in working systems.



The Quartus II Web Edition software and the Nios II EDS, Evaluation Edition are available free for download from the Altera® website. Visit [www.altera.com/download](http://www.altera.com/download). Also, for further reference, see the [Design Examples](#).

This chapter does not describe downloading and verifying a working system in hardware. Therefore, there are no hardware requirements for the completion of this chapter. However, the example memory subsystem has been tested in hardware.

## Design Flow

This section describes the design flow for building memory subsystems with SOPC Builder, which is similar to other SOPC Builder designs. After starting a Quartus II project and an SOPC Builder system, there are five steps to completing the system, as shown in Figure 9-2:

1. Component-level design in SOPC Builder
2. SOPC Builder system-level design
3. Simulation
4. Quartus II project-level design
5. Board-level design

**Figure 9-2. Design Flow**

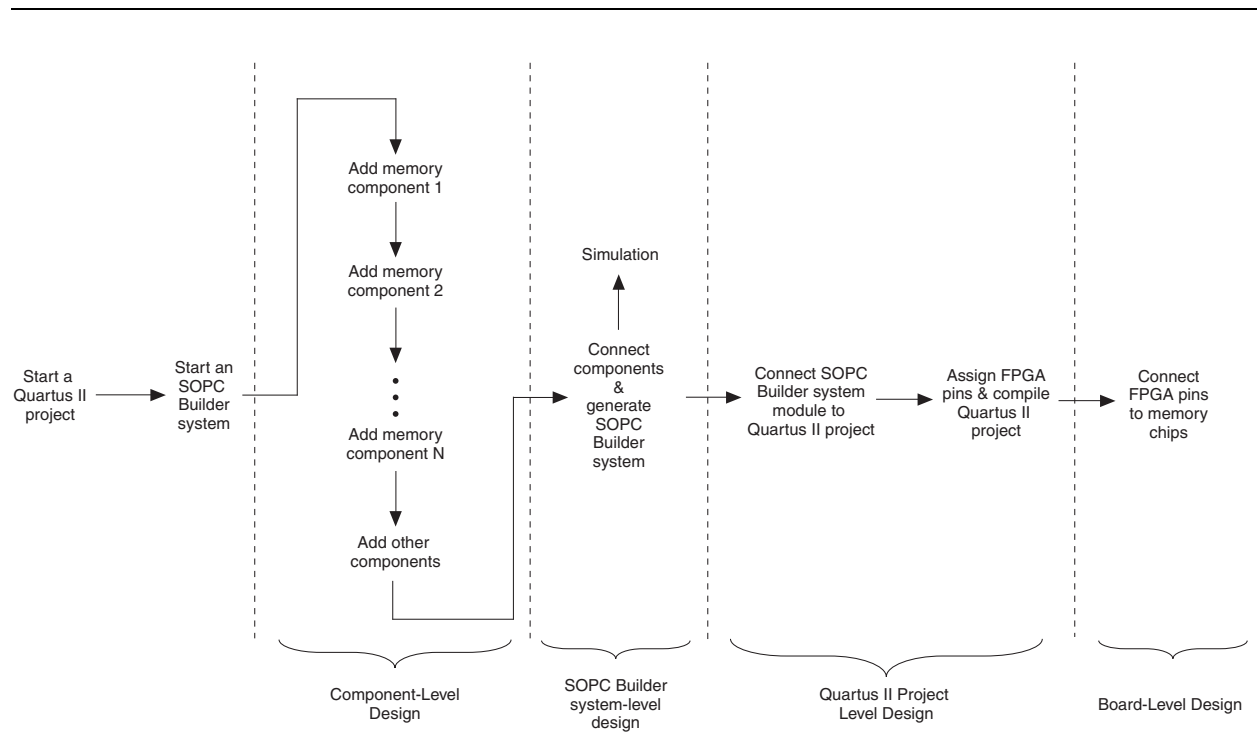

### Component-Level Design in SOPC Builder

In this step, you specify which memory components to use and configure each component to meet the needs of the system. All memory components are available from the **Memory and Memory Controllers** category in the list of available components in SOPC Builder.

### SOPC Builder System-Level Design

In this step, you connect components together and configure the SOPC Builder system as a whole. Like the process of adding non-memory SOPC Builder components, you use the **System Contents** tab to do the following:

- Rename the component instance (optional).



- Connect the memory component to masters in the system. Each memory component must be connected to at least one master.
- Assign a base address.
- Assign a clock domain. A memory component can operate on the same or different clock domain as the master(s) that access it.

## Simulation

In this step, you verify the functionality of the SOPC Builder system. For systems with memories, this step depends on simulation models for each of the memory components, in addition to the system testbench generated by SOPC Builder. Refer to “[Simulation Considerations](#)” for more information.

## Quartus II Project-Level Design

In this step, you integrate the SOPC Builder system with the rest of the Quartus II project, which includes connecting the SOPC Builder system to FPGA pins, connecting wiring the SOPC Builder system to other design blocks (such as other HDL modules) in the Quartus II project.

 In the example design in this chapter, the SOPC Builder system comprises the entire FPGA design. There are no other design blocks in the Quartus II project.

## Board-Level Design

In this step, you connect the physical FPGA pins to memory devices on the board. If the SOPC Builder system interfaces with off-chip memory devices, you must make board-level design choices.

## Simulation Considerations

SOPC Builder can automatically generate a testbench for RTL simulation of the system using ModelSim®. This testbench instantiates the SOPC Builder system and can also instantiate memory models for external memory components. The testbench is plain text HDL, located at the bottom of the top-level SOPC Builder system HDL design file. To explore the contents of the auto-generated testbench, open the top-level HDL file and search on keyword `test_bench`.

 Beginning in ModelSim SE 6.2, design optimization is on by default. Optimization may eliminate design nodes which are referenced in your wave display file. In this case, you cannot display the waveforms. You can ignore this failure if you want to run an optimized simulation. However, if you want to see the simulation signals, you can disable the optimized compile by setting `VoptFlow = 0` in your `modelsim.ini` file. The `modelsim.ini` is stored in the top-level directory of the ModelSim installation.

## Generic Memory Models

The memory components described in this chapter, except for the SRAM, provide generic simulation models. Therefore, it is very easy to simulate an SOPC Builder system with memory components immediately after generating the system.

The generic memory models store memory initialization files, such as Data (.dat) and Hexadecimal (.hex) files, in a directory named *<Quartus II project directory>/<SOPC Builder system name>\_sim*. When generating a new system, SOPC Builder creates empty initialization files. You can manually edit these files to provide custom memory initialization contents for simulation.

### Vendor-Specific Memory Models

You can also manually connect vendor-specific memory models to the SOPC Builder system. In this case, you must manually edit the testbench and connect the vendor memory model. You might also need to edit the vendor memory model slightly for time delays. The SOPC Builder testbench assumes zero delay.

## On-Chip RAM and ROM

Altera FPGAs include on-chip memory blocks that can be used as RAM or ROM in SOPC Builder systems. On-chip memory has the following benefits for SOPC Builder systems:

- On-chip memory has fast access time, compared to off-chip memory.
- SOPC Builder automatically instantiates on-chip memory inside the SOPC Builder system, so you do not have to make any manual connections.
- Certain memory blocks can have initialized contents when the FPGA powers up. This feature is useful, for example, for storing data constants or processor boot code.
- On-chip memories support dual port accesses, allowing two master to access the same memory concurrently.

### Component-Level Design for On-Chip Memory

In SOPC Builder you instantiate on-chip memory by clicking **On-chip Memory (RAM or ROM)** from the list of available components. The configuration wizard for the **On-chip Memory (RAM or ROM)** component has the following options: **Memory type**, **Size**, and **Read latency**.

#### Memory Type

The **Memory type** options define the structure of the on-chip memory:

- **RAM (writable)**—This setting creates a readable and writable memory.
- **ROM (read only)**—This setting creates a read-only memory.
- **Dual-port access**—This setting creates a memory component with two slaves, which allows two masters to access the memory simultaneously.



If two masters access the same address simultaneously in a dual-port memory undefined results will occur. (Concurrent accesses are only a problem for two writes. A read and write to the same location will read out the old data and store the new data.)

- **Block type**—This setting directs the Quartus II software to use a specific type of memory block when fitting the on-chip memory in the FPGA.



The MRAM blocks do not allow the contents to be initialized during power up. The M512s memory type does not support dual-port mode where both ports support both reads and writes.

Because of the constraints on some memory types, it is frequently best to use the **Auto** setting. **Auto** allows the Quartus II software to choose a type and the other settings direct the Quartus II software to select a particular type.

## Size

The **Size** options define the size and width of the memory.

- **Data width**—This setting determines the data width of the memory. The available choices are **8, 16, 32, 64, 128, 256, 512, or 1024** bits. Assign **Data width** to match the width of the master that accesses this memory the most frequently or has the most critical throughput requirements. For example, if you are connecting the on-chip memory to the data master of a Nios II processor, you should set the data width of the on-chip memory to 32 bits, the same as the data-width of the Nios II data master. Otherwise, the access latency could be longer than one cycle because the Avalon interconnect fabric performs width translation.
- **Total memory size**—This setting determines the total size of the on-chip memory block. The total memory size must be less than the available memory in the target FPGA.
- **Minimize memory block usage (may impact fmax)**—Minimize memory block usage (may impact fmax)—This option is only available for devices that include M4K memory blocks. If selected, the Quartus II software divides the memory by depth rather than width, so that fewer memory blocks are used. This change may decrease fmax.

## Read Latency

On-chip memory components use synchronous, pipelined Avalon-MM slaves. Pipelined access improves  $f_{MAX}$  performance, but also adds latency cycles when reading the memory. The **Read latency** option allows you to specify either one or two cycles of read latency required to access data. If the **Dual-port access** setting is turned on, you can specify a different read latency for each slave. When you have dual-port memory in your system you can specify different clock frequencies for the ports. You specify this on the **System Contents** tab in SOPC Builder.

## Non-Default Memory Initialization

For ROM memories, you can specify your own initialization file by selecting **Enable non-default initialization file**. This option allows the file you specify to be used to initialize the ROM in place of the default initialization file created by SOPC Builder.

## Enable In-System Memory Content Editor Feature

Enables a JTAG interface used to read and write to the RAM while it is operating. You can use this interface to update or read the contents of the memory from your host PC.



For more information refer to *In-System Updating of Memory and Constants* in volume 3 of the *Quartus II Handbook*.

## SOPC Builder System-Level Design for On-Chip Memory

There are few SOPC Builder system-level design considerations for on-chip memories. See “SOPC Builder System-Level Design” on page 9-4.

When generating a new system, SOPC Builder creates a blank initialization file in the Quartus II project directory for each on-chip memory that can power up with initialized contents. The name of this file is *<name of memory component>.hex*.

## Simulation for On-Chip Memory

At system generation time, SOPC Builder generates a simulation model for the on-chip memory. This model is embedded inside the SOPC Builder system, and there are no user-configurable options for the simulation testbench.

You can provide memory initialization contents for simulation in the file *<Quartus II project directory>/<SOPC Builder system name>\_sim/<Memory component name>.dat*.

## Quartus II Project-Level Design for On-Chip Memory

The on-chip memory is embedded inside the SOPC Builder system, and there are no signals to connect to the Quartus II project.

To provide memory initialization contents, you must fill in the file *<name of memory component>.hex*. The Quartus II software recognizes this file during design compilation and incorporates the contents into the configuration files for the FPGA.



For the memory to be initialized, you then must compile the hardware in the Quartus II software for the SRAM Object File (.sof) to pick up the memory initialization files. All memory types with the exception of MRAMs support this feature.

## Board-Level Design for On-Chip Memory

The on-chip memory is embedded inside the SOPC Builder system, and there is nothing to connect at the board level.

## Example Design with On-Chip Memory

This section demonstrates adding a 4 KByte on-chip RAM to the example design. This memory uses a single slave interface with a read latency of one cycle.

For demonstration purposes, Figure 9-3 shows the result of generating the SOPC Builder system at this stage. (In a normal design flow, you generate the system only after adding all system components.)

**Figure 9-3. SOPC Builder System with On-Chip Memory**

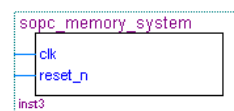

Because the on-chip memory is contained entirely within the SOPC Builder system, `sopc_memory_system` has no I/O signals associated with `onchip_ram`. Therefore, you do not need to make any Quartus II project connections or assignments for the on-chip RAM, and there are no board-level considerations.

## EPCS Serial Configuration Device

Many systems use an Altera EPCS serial configuration device to configure the FPGA. Altera provides the EPCS device controller core, which allows SOPC Builder systems to access the memory contents of the EPCS device.

This feature provides flexible design options:

- The FPGA design can reprogram its own configuration memory, providing a mechanism for remote upgrades.
- The FPGA design can use leftover space in the EPCS as nonvolatile storage.

Physically, the EPCS device is a serial flash memory device, which has slow access time. Altera provides software drivers to control the EPCS core for the Nios II processor only.

 For further details about the features and usage of the EPCS device controller core, refer to the *EPCS Device Controller Core* chapter in the *Embedded Peripherals IP User Guide*.

## Component-Level Design for an EPCS Device

In SOPC Builder you instantiate an EPCS controller core by adding an **EPCS Serial Flash Controller** component. There are no settings for this component.

 For details, refer to the *Nios II Flash Programmer User Guide*.

## SOPC Builder System-Level Design for an EPCS Device

There are two SOPC Builder system-level design considerations for EPCS devices:

- Assign a base address.
- Set the IRQ connection to **NC** (no connect). The EPCS controller hardware is capable of generating an IRQ. However, the Nios II driver software does not use this IRQ, and therefore you can leave the IRQ signal disconnected.

There can only be one EPCS controller core per FPGA, and the instance of the core is always named `epcs_controller`.

If you want to store Nios II code in the EPCS memory, point the Nios II reset address at the EPCS controller. Inside the EPCS controller is a bootloader, which Nios II runs after it leaves reset, that copies the code from the EPCS flash into main memory.

## Simulation for an EPCS Device

The EPCS controller core provides a limited simulation model:

- Functional simulation does not include the FPGA configuration process, and therefore the EPCS controller does not model the configuration features.

- The simulation model does not support read and write operations to the flash region of the EPCS device.
- A Nios II processor can boot from the EPCS device in simulation. However, the boot loader code is different during simulation. The EPCS controller boot loader code assumes that all other memory simulation models are initialized, and therefore the boot load process is unnecessary. During simulation, the boot loader simply forces the Nios II processor to jump to start, skipping the boot load process.

Verification in the hardware is the best way to test features related to the EPCS device.

## Quartus II Project-Level Design for an EPCS Device

If you use a device from Cyclone III, Stratix III, or Stratix IV families, you must connect the EPCS pins manually.

For earlier device families, however, the Quartus II software automatically connects the EPCS controller core in the SOPC Builder system to the dedicated configuration pins on the FPGA. This connection is invisible to you. Therefore, there are no EPCS-related signals to connect in the Quartus II project.

## Board-Level Design for an EPCS Device

You must connect the EPCS device to the FPGA as described in the Altera *Configuration Handbook*. No other connections are necessary.

## Example Design with an EPCS Device

This section demonstrates adding an EPCS device controller core to the example design.

For demonstration purposes only, Figure 9-4 shows the result of generating the SOPC Builder system at this stage.

**Figure 9-4. SOPC Builder System with EPCS Device**

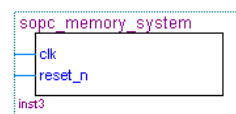

Because the Quartus II software automatically connects the EPCS controller core to the FPGA pins, the SOPC Builder system has no I/O signals associated with **epcs\_controller**. Therefore, you do not need to make any connections or assignments between the Quartus II project and the EPCS controller core.



This chapter does not cover the details of configuration using the EPCS device. For further information, refer to the Altera *Configuration Handbook*.

## SDR SDRAM

Altera provides a free SDR SDRAM controller core, which allows you to use inexpensive SDRAM as bulk RAM in your FPGA designs. The SDR SDRAM controller core is necessary, because Avalon-MM signals cannot describe the complex interface on an SDRAM device. The SDR SDRAM controller acts as a bridge between the system interconnect fabric and the pins on an SDRAM device. The SDR SDRAM controller can operate in excess of 100 MHz.

SDR SDRAM is a single data rate SDR SDRAM. Synchronous design allows precise cycle control. With the use of system clock, I/O transactions are possible on every clock cycle. Operating over a range of frequencies, programmable latencies allow the same device to be useful for a variety of high bandwidth, high performance memory system applications.

-  For further details about the features and usage of the SDR SDRAM controller core, refer to the *SDR-SDRAM Controller Core with Avalon Interface* chapter in the *Embedded Peripherals IP User Guide*.

### Component-Level Design for SDRAM

The choice of SDRAM device(s) and the configuration of the device(s) on the board heavily influence the component-level design for the SDRAM controller. Typically, the component-level design task involves parameterizing the SDRAM controller core to match the SDRAM device(s) on the board. You must specify the structure (address width, data width, number of devices, number of banks, and so on) and the timing specifications of the device(s) on the board.

-  For complete details about configuration options for the SDRAM controller core, refer to the *SDRAM Controller Core* chapter in the *Embedded Peripherals IP User Guide*.

### SOPC Builder System-Level Design for SDRAM

You can select the SDRAM controller in the SOPC Builder **System Contents** tab. Like the on-chip memory, there are few SOPC Builder system-level design considerations for SDRAM. Refer to *“SOPC Builder System-Level Design” on page 9-4*.

### Simulation for SDRAM

At system generation time, SOPC Builder can generate a generic SDRAM simulation model and include the model in the system testbench. To use the generic SDRAM simulation model, you must turn on a setting in the SDRAM controller configuration wizard. You can provide memory initialization contents for simulation in the file `<Quartus II project directory>/<SOPC Builder system name>_sim/<Memory component name>.dat`.

Alternatively, you can provide a specific vendor memory model for the SDRAM. In this case, you must manually wire up the vendor memory model in the system testbench.

-  For further details, refer to *“Simulation Considerations” on page 9-5* and the *SDRAM Controller Core* chapter in the *Embedded Peripherals IP User Guide*.

## Quartus II Project-Level Design for SDRAM

SOPC Builder generates a SOPC Builder system with top-level I/O signals associated with the SDRAM controller. In the Quartus II project, you must connect these I/O signals to FPGA pins, which connect to the SDRAM device on the board. In addition, you might have to accommodate clock skew issues.

### Connecting and Assigning the SDRAM-Related Pins

After generating the system with SOPC Builder, you can find the names and directions of the I/O signals in the top-level HDL file for the SOPC Builder system. The file has the name

`<Quartus II project directory>/<SOPC Builder system name>.v` or `<Quartus II project directory>/<SOPC Builder system name>.vhd`. You must connect these signals in the top-level Quartus II design file.

You must assign a pin location for each I/O signal in the top-level Quartus II design to match the target board. Depending on the performance requirements for the design, you might have to assign FPGA pins carefully to achieve the required performance.

### Accommodating Clock Skew

As SDRAM frequency increases, so does the possibility that you must accommodate skew between the SDRAM clock and I/O signals. This issue affects all synchronous memory devices, including SDRAM. To accommodate clock skew, you can instantiate an ALTPLL megafunction in the top-level Quartus II design to create a phase-locked loop (PLL) clock output. You use a phase-shifted PLL output to drive the SDRAM clock and reduce clock-skew issues. The exact settings for the ALTPLL megafunction depend on your target hardware. You must experiment to tune the phase shift to match the board.



For details, refer to the [ALTPLL Megafunction User Guide](#).

## Board-Level Design for SDRAM

Memory requirements largely dictate the board-level configuration of the SDRAM device or devices. The SDRAM controller core can accommodate various configurations of SDRAM on the board, including multiple banks and multiple devices.

## Example Design with SDR SDRAM

This section demonstrates adding a 16-Mbyte SDRAM device to the example design, using the SDRAM Controller configuration wizard. This SDRAM is a single device with 32-bit data.



For demonstration purposes, Figure 9-5 shows the result of generating the SOPC Builder system at this stage, and connecting it in `toplevel_design.bdf`.

Figure 9-5. `toplevel_design.bdf` with SDRAM

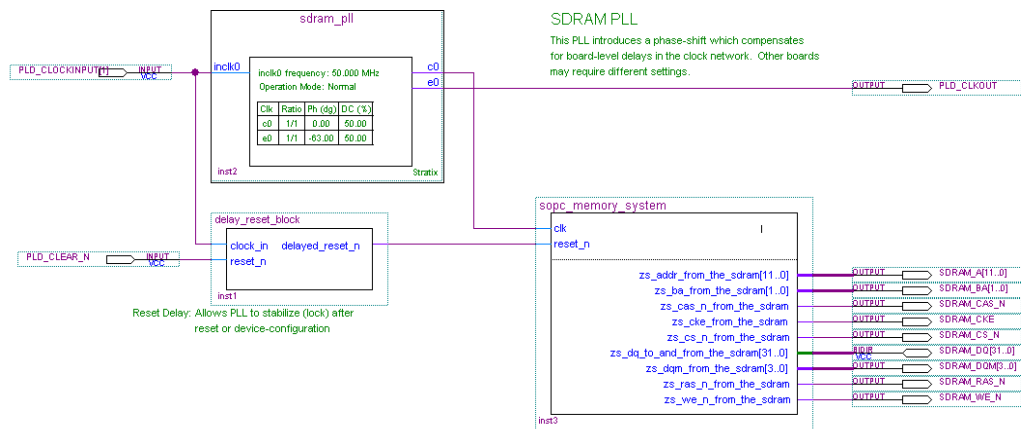

After generating the system, the top-level SOPC Builder system file `sopc_memory_system.v` contains the list of SDRAM-related I/O signals that must be connected to FPGA pins. Example 9-1 shows these pins.

**Example 9-1. I/O Signals Connected to FPGA Pins**

```
output [ 11: 0] zs_addr_from_the_sdram;
output [  1: 0] zs_ba_from_the_sdram;
output          zs_cas_n_from_the_sdram;
output          zs_cke_from_the_sdram;
output          zs_cs_n_from_the_sdram;
inout  [ 31: 0] zs_dq_to_and_from_the_sdram;
output  [  3: 0] zs_dqm_from_the_sdram;
output          zs_ras_n_from_the_sdram;
output          zs_we_n_from_the_sdram;
```

As shown in Figure 9-5, `toplevel_design.bdf` uses an instance of `sdr_pll` to phase shift the SDRAM clock by -63 degrees. (Degrees are relative to clock frequency. If you change the clock speed you must change the phase shift. You should parameterize the PLL with -3.5 ns, because the compensation is for the round-trip delays and clock to I/O delays.)

`toplevel_design.bdf` also uses a subdesign `delay_reset_block` to insert a delay on the `reset_n` signal for the SOPC Builder system. This delay is necessary to allow the PLL output to stabilize before the SOPC Builder system begins operating.

Figure 9-6 shows pin assignments in the Quartus II Assignment Editor for some of the SDRAM pins. The correct pin assignments depend on the target board.

**Figure 9-6. Pin Assignments for SDRAM**

	To	Location	I/O Bank	I/O Standard	General Function	Special Function	Reserved
188	SDRAM_A[0]	PIN_AE4	7	LVTTL	Column I/O		
189	SDRAM_A[10]	PIN_Y11	7	LVTTL	Column I/O		
190	SDRAM_A[11]	PIN_AB7	7	LVTTL	Column I/O		
191	SDRAM_A[1]	PIN_W12	7	LVTTL	Column I/O	PGM0	
192	SDRAM_A[2]	PIN_AC11	7	LVTTL	Column I/O	nRS	
193	SDRAM_A[3]	PIN_W10	7	LVTTL	Column I/O	RUnLU	
194	SDRAM_A[4]	PIN_AA11	7	LVTTL	Column I/O	PGM1	
195	SDRAM_A[5]	PIN_AC10	7	LVTTL	Column I/O	RDN7	
196	SDRAM_A[6]	PIN_AB11	7	LVTTL	Column I/O	RUP7	
197	SDRAM_A[7]	PIN_AC8	7	LVTTL	Column I/O	FCLK5	
198	SDRAM_A[8]	PIN_AB10	7	LVTTL	Column I/O	FCLK4	
199	SDRAM_A[9]	PIN_V11	7	LVTTL	Column I/O		
200	SDRAM_BA[0]	PIN_AG19	8	LVTTL	Column I/O	DQ6B4	
201	SDRAM_BA[1]	PIN_AF19	8	LVTTL	Column I/O	DQ6B5	
202	SDRAM_CAS_N	PIN_AD18	8	LVTTL	Column I/O	DQ6B2	
203	SDRAM_CKE	PIN_AE18	8	LVTTL	Column I/O	DQ6B1	
204	SDRAM_CS_N	PIN_AG18	8	LVTTL	Column I/O	DQ6B0	
205	SDRAM_DQM[0]	PIN_AE14	7	LVTTL	Column I/O	CLK6n	
206	SDRAM_DQM[1]	PIN_Y13	7	LVTTL	Column I/O	CLK7n	
207	SDRAM_DQM[2]	PIN_AE7	7	LVTTL	Column I/O	DQ51B	
208	SDRAM_DQM[3]	PIN_AG10	7	LVTTL	Column I/O	DQ53B	

## DDR SDRAM

You can use double-data rate (DDR) SDRAM devices for a broad range of applications, such as embedded processor systems, image processing, storage, communications, and networking. In addition, the universal adoption of DDR SDRAM in PCs makes DDR SDRAM memory a solution for high-bandwidth applications. DDR SDRAM is a  $<2n>$  prefetch architecture where the internal data bus is twice the width of the external data bus and data transfers occur on both clock edges. It uses a strobe, DQS, which is associated with a group of data pins (DQ) for read and write operations. Both the DQS and DQ ports are bidirectional. Address ports are shared for write and read operations.

## DDR2 SDRAM

Double-data rate DDR2 SDRAM is the second generation of double-data rate DDR SDRAM technology, with features such as lower power consumption, higher data bandwidth, enhanced signal quality, and on-die termination. DDR2 SDRAM brings higher memory performance to a broad range of applications, such as PCs, embedded processor systems, image processing, storage, communications, and networking. It is a  $<4n>$  pre-fetch architecture with two data transfers per clock cycle. The memory uses a strobe (DQS) associated with a group of data pins (DQ) for read and write operations. Both the DQ and DQS ports are bidirectional. Address ports are shared for write and read operations.



For more information refer to [Literature: External Memory Interfaces](#) page of the Altera website.

## Off-Chip SRAM and Flash Memory

SOPC Builder systems can directly access many off-chip RAM and ROM devices, without a controller core to drive the off-chip memory. Avalon-MM signals can describe the interfaces on many standard memories, such as SRAM and flash memory. I/O signals on the SOPC Builder system can connect directly to the memory device.

While off-chip memory usually has slower access time than on-chip memory, off-chip memory provides the following benefits:

- Off-chip memory cost-per-bit is less expensive than on-chip memory resources.
- The size of off-chip memory is bounded only by the 32-bit Avalon-MM address space.
- Off-chip ROM, such as flash memory, can be used for bulk storage of nonvolatile data.
- Multiple off-chip RAM and ROM memories can share address and data pins to conserve FPGA I/O resources at the expense of throughput.

Adding off-chip memories to an SOPC Builder system also requires the **Avalon-MM Tristate Bridge** component.

### Component-Level Design for SRAM and Flash Memory

There are several ways to instantiate an interface to an off-chip memory device:

- For common flash interface (CFI) flash memory devices, add the **Flash Memory (Common Flash Interface)** component in SOPC Builder.
- For Altera development boards, Altera provides SOPC Builder components that interface to the specific devices on each development board. For example, the Nios II EDS includes the components **Cypress CY7C1380C SSRAM** and **IDT71V416 SRAM**, which appear on Nios II development boards.

 For further details about the features and usage of the SSRAM controller core, refer to the *Nios Development Board Cyclone II Edition Reference Manual* or *Nios Development Board Stratix II Edition*.

 For further details about the features and usage of the SDRAM controller core, refer to [Chapter 9, SOPC Builder Memory Subsystem Development Walkthrough](#).

These components make it easy for you to create memory systems targeting Altera development boards. However, these components target only the specific memory device on the board; they do not work for different devices.

- For general memory devices, RAM or ROM, you can create a custom interface to the device with the SOPC Builder component editor. Using the component editor, you define the I/O pins on the memory device and the timing requirements of the pins.

In all cases, you must also instantiate the **Avalon-MM Tristate Bridge** component. Multiple off-chip memories can connect to a single tristate bridge, in order to share pins such as the off-chip address bus.

## Avalon-MM Tristate Bridge

A tristate bridge connects off-chip devices to the system interconnect fabric. The tristate bridge creates I/O signals for the SOPC Builder system, which you must connect to FPGA pins in the top-level Quartus II project.

The tristate bridge creates address and data pins that can be shared by multiple off-chip devices. This feature lets you conserve FPGA pins when connecting the FPGA to multiple devices with mutually exclusive access.

You must use a tristate bridge in either of the following cases:

- The off-chip device has bidirectional data pins.
- Multiple off-chip devices share the address, data, or both address and data buses.

In SOPC Builder, you instantiate a tristate bridge by instantiating the **Avalon-MM Tristate Bridge** component. The Avalon-MM Tristate Bridge configuration wizard has a single option: To register incoming (to the FPGA) signals or not.

- **Registered**—This setting adds registers to all FPGA input pins associated with the tristate bridge (outputs from the memory device).
- **Not Registered**—This setting does not add registers between the memory device output pins and the system interconnect fabric.

The Avalon-MM tristate bridge automatically adds registers to output signals from the tristate bridge to off-chip devices.

Registering the input and output signals shortens the register-to-register delay from the memory device to the FPGA, resulting in higher system  $f_{MAX}$  performance. However, the registers add one additional cycle of latency for Avalon-MM masters accessing memory connected to the tristate bridge in each direction. The registers do not affect the timing (setup, hold, and wait) of the transfers from the perspective of the memory device.

 For details about the Avalon-MM tristate interface, refer to the [Avalon Interface Specifications](#).

## Flash Memory

In SOPC Builder, you instantiate an interface to CFI flash memory by adding a **Flash Memory (Common Flash Interface)** component. If the flash memory is not CFI compliant, you must create a custom interface to the device with the SOPC Builder component editor.

The choice of flash devices and the configuration of the devices on the board help determine the component-level design for the flash memory configuration wizard. Typically, the component-level design task involves parameterizing the flash memory interface to match the devices on the board. Using the Flash Memory (Common Flash Interface) configuration wizard, you must specify the structure (address width and data width) and the timing specifications of the flash memory devices.

 For details about features and usage, refer to the [Common Flash Interface Controller Core](#) chapter in the *Embedded Peripherals IP User Guide*.

For an example of instantiating the Flash Memory (Common Flash Interface) component in an SOPC Builder system, see “[Example Design with SRAM and Flash Memory](#)” on page 9–20.

## SRAM

To instantiate an interface to off-chip SRAM:

1. Create a new component with the SOPC Builder component editor that defines the interface.
2. Instantiate the new interface component in the SOPC Builder system.

The choice of RAM devices and the configuration of the devices on the board determine how you create the interface component. The component-level design task involves entering parameters into the component editor to match the devices on the board.

 For details about using the component editor, refer to [Chapter 6, Component Editor](#).

## SOPC Builder System-Level Design for SRAM and Flash Memory

In the SOPC Builder **System Contents** tab, the Avalon-MM tristate bridge has two ports:

- **Avalon-MM slave**—This port faces the on-chip logic in the SOPC Builder system. You connect this slave to on-chip masters in the system.
- **Avalon-MM tristate master**—This port faces the off-chip memory devices. You connect this master to the Avalon-MM tristate slaves on the interface components for off-chip memories.

You assign a clock to the Avalon-MM tristate bridge that determines the Avalon-MM clock cycle time for off-chip devices connected to the tristate bridge.

You must assign base addresses to each off-chip memory. The Avalon-MM tristate bridge does not have an address; it passes unmodified addresses from on-chip masters to off-chip slaves.

## Simulation for SRAM and Flash Memory

The SOPC Builder output for simulation depends on the type of memory components in the system:

- **Flash Memory (Common Flash Interface) component**—This component provides a generic simulation model. You can provide memory initialization contents for simulation in the file `<Quartus II project directory>/<SOPC Builder system name>_sim/<Flash memory component name>.dat`.
- **Custom memory interface created with the component editor**—In this case, you must manually connect the vendor simulation model to the system testbench. SOPC Builder does not automatically connect simulation models for custom memory components to the SOPC Builder system.

- Altera-provided interfaces to memory devices—Altera provides simulation models for these interface components. You can provide memory initialization contents for simulation in the file `<Quartus II project directory>/<SOPC Builder system name>_sim/<Memory component name>.dat`. Alternately, you can provide a specific vendor simulation model for the memory. In this case, you must manually wire up the vendor memory model in the system testbench.

For further details, see “Simulation Considerations” on page 9-5.

## Quartus II Project-Level Design for SRAM and Flash Memory

SOPC Builder generates an SOPC Builder system with top-level I/O signals associated with the tristate bridge and the memory interface components. In the Quartus II project, you must connect the I/O signals to FPGA pins, which connect to the memory devices on the board.

After generating the system with SOPC Builder, you can find the names and directions of the I/O signals in the top-level HDL file for the SOPC Builder system. The file has the name `<Quartus II project directory>/<SOPC Builder system name>.v` or `<Quartus II project directory>/<SOPC Builder system name>.vhd`. You must connect these signals in the top-level Quartus II design file.

You must assign a pin location for each I/O signal in the top-level Quartus II design to match the target board. Depending on the performance requirements for the design, you might have to assign FPGA pins carefully to achieve timing.

SOPC Builder inserts synthesis directives in the top-level SOPC Builder system HDL to assist the Quartus II fitter with signals that interface with off-chip devices. [Example 9-2](#) illustrates a directive. Using `FAST_OUTPUT_REGISTER=ON` places the output register in the IO block, reducing the off-chip delay.



For more information about improving IO timing refer to the I/O Specifications section in *The Quartus II TimeQuest Timing Analyzer* chapter in volume 3 of the *Quartus II Handbook* and the *Assignment Editor* chapter in volume 2 of the *Quartus II Handbook*.

### Example 9-2. Synthesis Directive

```
reg [ 22: 0] tri_state_bridge_address /* synthesis
ALTERA_ATTRIBUTE = "FAST_OUTPUT_REGISTER=ON" */;
```

## Board-Level Design for SRAM and Flash Memory

Memory requirements determine the board-level configuration of the SRAM and flash memory device or devices. You can lay out memory devices in any configuration, as long as the resulting interface can be described with Avalon-MM signals.



Special consideration is required when connecting the Avalon-MM address signal to the address pins on the memory devices.

The SOPC Builder system presents the smallest number of address lines required to access the largest off-chip memory, which is usually less than 32 address bits. Not all memory devices connect to all address lines.

## Aligning the Least-Significant Address Bits

The Avalon-MM tristate address signal always presents a byte address. Each address location in many memory devices contains more than one byte of data. In this case, the memory device must ignore one or more of the least-significant Avalon-MM address lines. For example, a 16-bit memory device must ignore Avalon-MM address [0] (which is a byte address), and connect Avalon-MM address [1] to the least-significant address line.

Table 9-1 shows the relationship between Avalon-MM address lines and off-chip address pins for all possible Avalon-MM data widths.

**Table 9-1. Connecting the Least-Significant Avalon-MM Address Line**

Avalon-MM Address Line	Address Line Connecting to Memory Device				
	8-bit Memory	16-bit Memory	32-bit Memory	64-bit Memory	128-bit Memory
address [0]	A0	No connect	No connect	No connect	No connect
address [1]	A1	A0	No connect	No connect	No connect
address [2]	A2	A1	A0	No connect	No connect
address [3]	A3	A2	A1	A0	No connect
address [4]	A4	A3	A2	A1	A0
address [5]	A5	A4	A3	A2	A1
address [6]	A6	A5	A4	A3	A2
address [7]	A7	A6	A5	A4	A3
address [8]	A8	A7	A6	A5	A4
address [9]	A9	A8	A7	A6	A5
address [10]	A10	A9	A8	A7	A6
...	...	...	...	...	...



You must ensure that the address bits are properly assigned when mixed width components are connecting to the tristate bridge. Failing to ensure that the components are properly aligned may result in a board respin.

## Aligning the Most-Significant Address Bits

The Avalon-MM address signal contains enough address lines for the largest memory connected to the tristate bridge. Smaller off-chip memories might not use all of the most-significant address lines as Figure 9-7 illustrates.

**Figure 9-7. Connecting a Tristate Bridge to Components with Different Address Widths and Word Sizes**

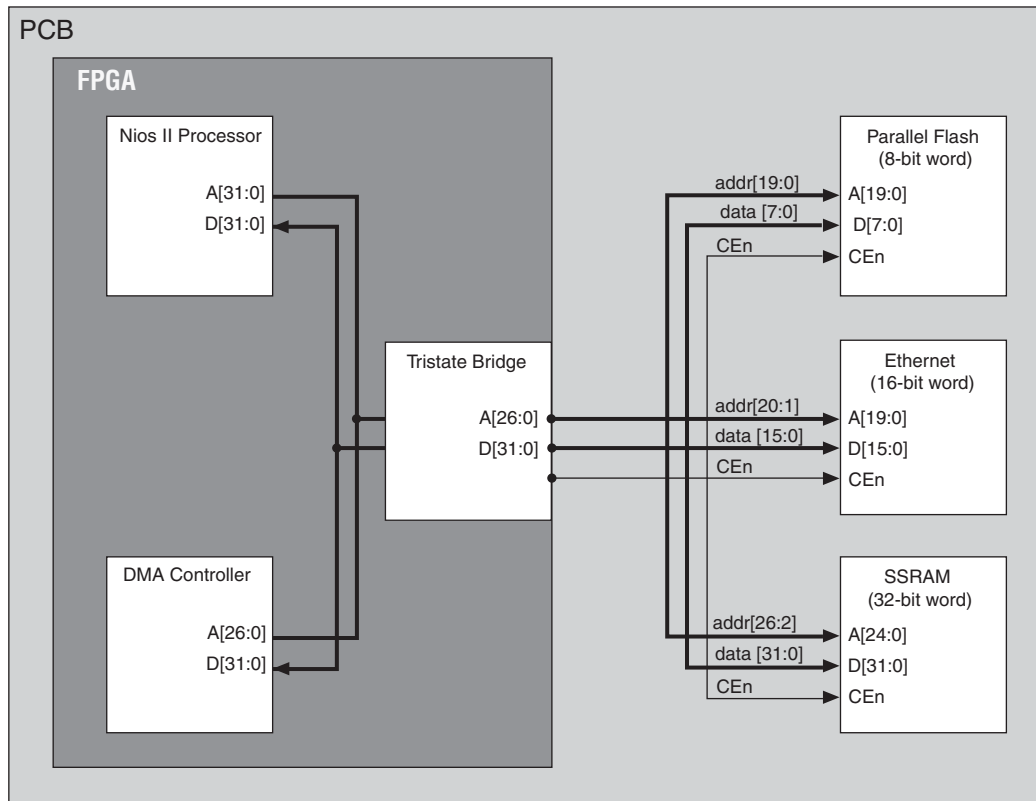

## Example Design with SRAM and Flash Memory

This section demonstrates adding a 1-MByte SRAM and an 8-MByte flash memory to the example design. These memory devices connect to the system interconnect fabric through an Avalon-MM tristate bridge.

### Adding the Avalon-MM Tristate Bridge

In the **Avalon-MM Tristate Bridge** configuration wizard, turn on the **Registered inputs and outputs** option to maximize system  $f_{MAX}$ , which increases the read latency by two for both the SRAM and flash memory.



## Adding the Flash Memory Interface

The flash memory is 8M × 8-bit, which requires 23 address bits and 8 data bits. Table 9-2 gives the Flash Memory (Common Flash Interface) settings for the example design.

**Table 9-2. Flash Memory Interface (CFI)**

Parameter	Value
<b>Attributes</b>	
Presets	AMD29LV065D12R
Address Width (bits)	23
Data Width (bits)	8
Timing	—
Setup	40
Wait	160
Hold	40
Units	ns

## Adding the SRAM Interface

The SRAM device is 256K × 32-bit, which requires 18 word address bits and 32 data bits. The example design uses a custom memory interface created with the SOPC Builder component editor.

## SOPC Builder System Contents Tab

Figure 9-8 shows the SOPC Builder system after adding the Tristate bridge and memory interface components, and configuring them appropriately on the **System Contents** tab. Figure 9-8 represents the complete example design in SOPC Builder.

**Figure 9-8. SOPC Builder System with SRAM and Flash Memory**

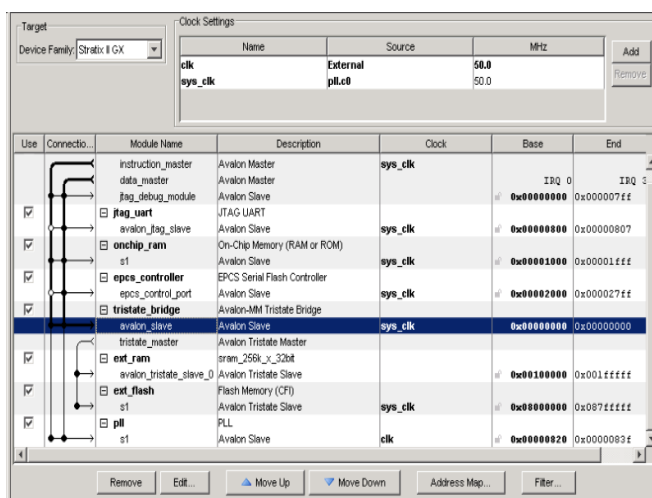

After generating the system, the top-level SOPC Builder system file `sopc_memory_system.v` contains the list of I/O signals for SRAM and flash memory that must be connected to FPGA pins, as shown in [Example 9-3](#).

### Example 9-3. I/O Signals for SRAM and Flash Memory

```

output          address_to_the_ext_flash[ 23..0];
output          address_to_the_ext_ram[ 19..0];
output          be_n_to_the_ext_ram[ 3..0];
output          read_n_to_the_ext_flash;
output          read_n_to_the_ext_ram;
output          read_n_to_the_ext_ram;
output          select_n_to_the_ext_flash;
output          select_n_to_the_ext_ram;
bidirectional   tristate_bridge_data [ 31..0]
output          write_n_to_the_ext_flash;
output          write_n_to_the_ext_ram;

```

The Avalon-MM tristate bridge signals that can be shared are named after the instance of the tristate bridge component, such as `tri_state_bridge_data[31:0]`.

## Connecting and Assigning Pins in the Quartus II Project

[Figure 9-9](#) shows the result of generating the SOPC Builder system for the complete example design.

**Figure 9-9. Top Level System with SRAM and Flash Memory**

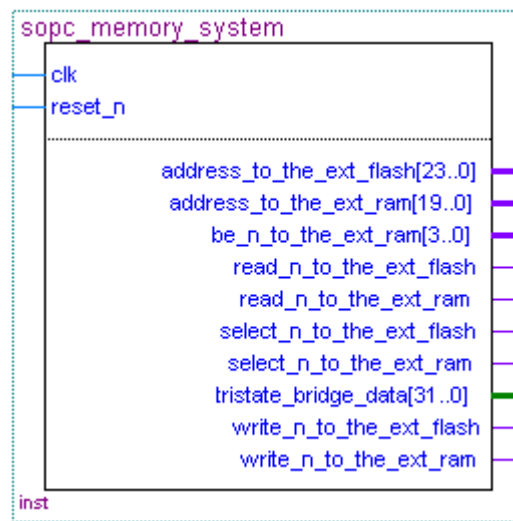

Figure 9-10 shows the pin assignments in the Quartus II Assignment Editor for some of the SRAM and flash memory pins. The correct pin assignments depend on the target board.

**Figure 9-10. Pin Assignments for SRAM and Flash Memory**

	To	Location	I/O Bank	I/O Standard	General Function	Special Function	Reser
243	SRAM_BE_N[0]	PIN_M18	3	LVTTTL	Column I/O		
244	SRAM_BE_N[1]	PIN_F17	3	LVTTTL	Column I/O		
245	SRAM_BE_N[2]	PIN_J18	3	LVTTTL	Column I/O	RUP3	
246	SRAM_BE_N[3]	PIN_L17	3	LVTTTL	Column I/O	CLK15n	
247	SRAM_CS_N	PIN_B24	3	LVTTTL	Column I/O	DQ9T4	
248	SRAM_OE_N	PIN_B26	3	LVTTTL	Column I/O	DQ9T7	
249	SRAM_WE_N	PIN_C24	3	LVTTTL	Column I/O	DQ59T	

## Connecting FPGA Pins to Devices on the Board

Table 9-3 shows the mapping between the Avalon-MM address lines and the address pins on the SRAM and flash memory devices.

**Table 9-3. FPGA Connections to SRAM and Flash Memory**

Avalon-MM Address Line	Flash Address (8M × 8-bit Data)	SRAM Address (256K × 32-bit data)
tri_state_bridge_address[0]	A0	No connect
tri_state_bridge_address[1]	A1	No connect
tri_state_bridge_address[2]	A2	A0
tri_state_bridge_address[3]	A3	A1
tri_state_bridge_address[4]	A4	A2
tri_state_bridge_address[5]	A5	A3
tri_state_bridge_address[6]	A6	A4
tri_state_bridge_address[7]	A7	A5
tri_state_bridge_address[8]	A8	A6
tri_state_bridge_address[9]	A9	A7
tri_state_bridge_address[10]	A10	A8
tri_state_bridge_address[11]	A11	A9
tri_state_bridge_address[12]	A12	A10
tri_state_bridge_address[13]	A13	A11
tri_state_bridge_address[14]	A14	A12
tri_state_bridge_address[15]	A15	A13
tri_state_bridge_address[16]	A16	A16
tri_state_bridge_address[17]	A17	A15
tri_state_bridge_address[18]	A18	A16
tri_state_bridge_address[19]	A19	A17
tri_state_bridge_address[20]	A20	No connect
tri_state_bridge_address[21]	A21	No connect
tri_state_bridge_address[22]	A22	No connect



This chapter describes the parts of a custom SOPC Builder component and guides you through the process of creating an example custom component, integrating it into a system, and testing it in hardware.

This chapter is divided into the following sections:

- [“Component Development Flow” on page 10–2.](#)
- [“Design Example: Checksum Hardware Accelerator” on page 10–4.](#) This design example shows you how to develop a component with both Avalon® Memory-Mapped (Avalon-MM) master and slaves.
- [“Sharing Components” on page 10–7.](#) This section shows you how to use components in other systems, or share them with other designers.
- [“System Information Files \(.sopcinfo\)” on page 10–7.](#)

## SOPC Builder Components and the Component Editor

An SOPC Builder component is usually composed of the following four types of files:

- HDL files—define the component’s functionality as hardware.
- Hardware Component Description File (`_hw.tcl`)—describes the SOPC Builder related characteristics, such as interface behaviors. This file is created by the component editor.
- C-language files—define the component register map and driver software to allow programs to control the component.
- Software Component Description File (`_sw.tcl`) file—used by the software build tools to use and compile the component driver code.

The component editor guides you through the creation of your component. You can then instantiate the component in an SOPC Builder system and make connections in the same manner as other SOPC Builder components. You can also share your component with other designers.

For information about creating the `_sw.tcl` file, see the [Developing Device Drivers for the Hardware Abstraction Layer](#) chapter in the *Nios II Software Developer’s Handbook*.

## Prerequisites

This chapter assumes that you are familiar with the following:

- Building systems with SOPC Builder. For details, refer to [Chapter 1, Introduction to SOPC Builder](#).
- SOPC Builder components. For details, refer to [Chapter 4, SOPC Builder Components](#).
- Basic concepts of the Avalon-MM interface.

## Hardware and Software Requirements

To use the design example in this chapter, in addition to the current version of the Quartus II software and Nios II Embedded Design Suite, you must have the following:

- Design files for the example design—A hyperlink to the design files appears next to this user guide, on the [SOPC Builder literature page](#).
- Nios development board and an Altera® USB-Blaster™ download cable—You can use either of the following Nios development boards:
  - Stratix® II Edition, RoHS compliant version
  - Cyclone® II Edition

If you do not have a development board, you can follow the hardware development steps. You cannot download the complete system without a working board, but you can simulate the system.



You can download the Quartus II Web Edition software and the Nios II EDS, Evaluation Edition for free from the Altera Download Center at [www.altera.com](http://www.altera.com).

## Component Development Flow

This section provides an overview of the development process for SOPC Builder components.

### Typical Design Steps

A typical development sequence for an SOPC Builder component includes the following items:

1. Specification and definition.
  - a. Define the functionality of the component.
  - b. Determine component interfaces, such as Avalon Memory-Mapped (Avalon-MM), Avalon Streaming (Avalon-ST), interrupt, or other interfaces.
  - c. Determine the component clocking requirements; what interfaces are synchronous to what clock inputs.
  - d. If you want a microprocessor to control the component, determine the interface to software, such as the register map.
2. Implement the component in VHDL or Verilog HDL.

3. Import the component into SOPC Builder.
  - a. Use the component editor to create a `_hw.tcl` file that describes the component.
  - b. Instantiate the component into an SOPC Builder system.

When importing an HDL file using the component editor, any parameter definitions that are dependent upon other defined parameters cause an error.

[Example 10-1](#) illustrates the declaration of a `DEPTH` parameter which is legal Verilog HDL syntax in the Quartus II software, but causes an error in the component editor syntax checker.

---

#### Example 10-1. DEPTH Parameter

```
parameter WIDTH = 32;  
parameter DEPTH = ((WIDTH == 32) ? 8 : 16);
```

---

To avoid this error, use a `localparam` for the dependent parameter instead, as shown in [Example 10-2](#).

---

#### Example 10-2. localparam Parameter

```
parameter WIDTH = 32;  
localparam DEPTH = ((WIDTH == 32) ? 8 : 16);
```

---

 SOPC Builder only supports the VHDL port types `std_logic` and `std_logic_vector`.

4. Develop the software driver, which can occur in parallel with the hardware implementation. Create the component's driver, including a C header file that defines the hardware-level register map for software.
  -  For further details, see the *Nios II Software Developer's Handbook*.
5. Perform in-system testing, such as the following:
  - a. Test register-level accesses to the component in hardware or simulation using a microprocessor, such as the Nios II processor.
  - b. Performance benchmarking.

## Hardware Design

As with any logic design process, the development of SOPC Builder component hardware begins after the specification phase. Creating the HDL design is often an iterative process, as you write and verify the HDL logic against the specification.

The architecture of a typical component consists of the following functional blocks:

- Task logic—Implements the component's fundamental function. The task logic is design dependent.
- Interface logic—Provides a standard way of providing data to or getting data from the components and of controlling the functioning of the components.



 For further details, refer to the *Avalon Interface Specifications*.

Figure 10-1 shows the top-level blocks of a checksum component, which includes both Avalon-MM master and slaves.

-  The work flow for developing SOPC Builder hardware, including how to decide upon and implement the register map, is described in the *Using the Nios II Software Build Tools* chapter in the *Nios II Software Developer's Handbook*. Also, guidelines for developing device drivers is described in the *Developing Device Drivers for the Hardware Abstraction Layer* chapter of the *Nios II Software Developer's Handbook*.

## Design Example: Checksum Hardware Accelerator

Altera has provided a checksum hardware accelerator design example to demonstrate the steps to create a component and instantiate it in a system. This design example is available for download from the Altera literature website. Included in the compressed download file is a **readme.pdf** that describes how to create and compile the hardware design, and describes how to use the checksum hardware accelerator in your design.

You can use the checksum algorithm in network applications where data integrity must be inspected by the receiving device. The checksum algorithm accumulates data with end-round-carry summation, which means that the carry bit from the accumulator is added to the least significant bit of the next input. After the data is accumulated, you can use the result to verify the data integrity of the data buffer. Because the checksum algorithm operates over a data buffer, you can implement it more efficiently with a pipelined read master. A pipelined read master continuously posts read transactions minimizing the effects of the memory read latency. The checksum accelerator can read data and calculate the checksum result every clock cycle, which you cannot do with a general purpose processor.

The checksum hardware accelerator requires information from a host processor such as the buffer base address, buffer length, and various control signals. As a result, the hardware accelerator exposes an Avalon-MM slave interface so that a host processor can control the read master operation. The host processor also accesses the checksum result from the slave interface. Each piece of information sent or read by the host processor is accessed separately in the register file implemented with the slave interface. For example, the status and control signals are implemented as separate registers because they contain information used for different purposes and have different access capabilities.



Hardware accelerators can operate in parallel with a host processor; consequently, adding an interrupt sender interface to the hardware accelerator increases system performance. While the accelerator is operating on a buffer, the host processor can perform other tasks such as preparing another buffer for transmission. The interrupt is asserted after the buffer checksum is calculated. The host processor can be interrupted by the hardware accelerator to notify it that a checksum result has been calculated. The host processor can then read the checksum value and clear the interrupt by writing to the status register via the accelerator slave interface.

**Figure 10–1. Checksum Component with Avalon-MM Master and Slaves**

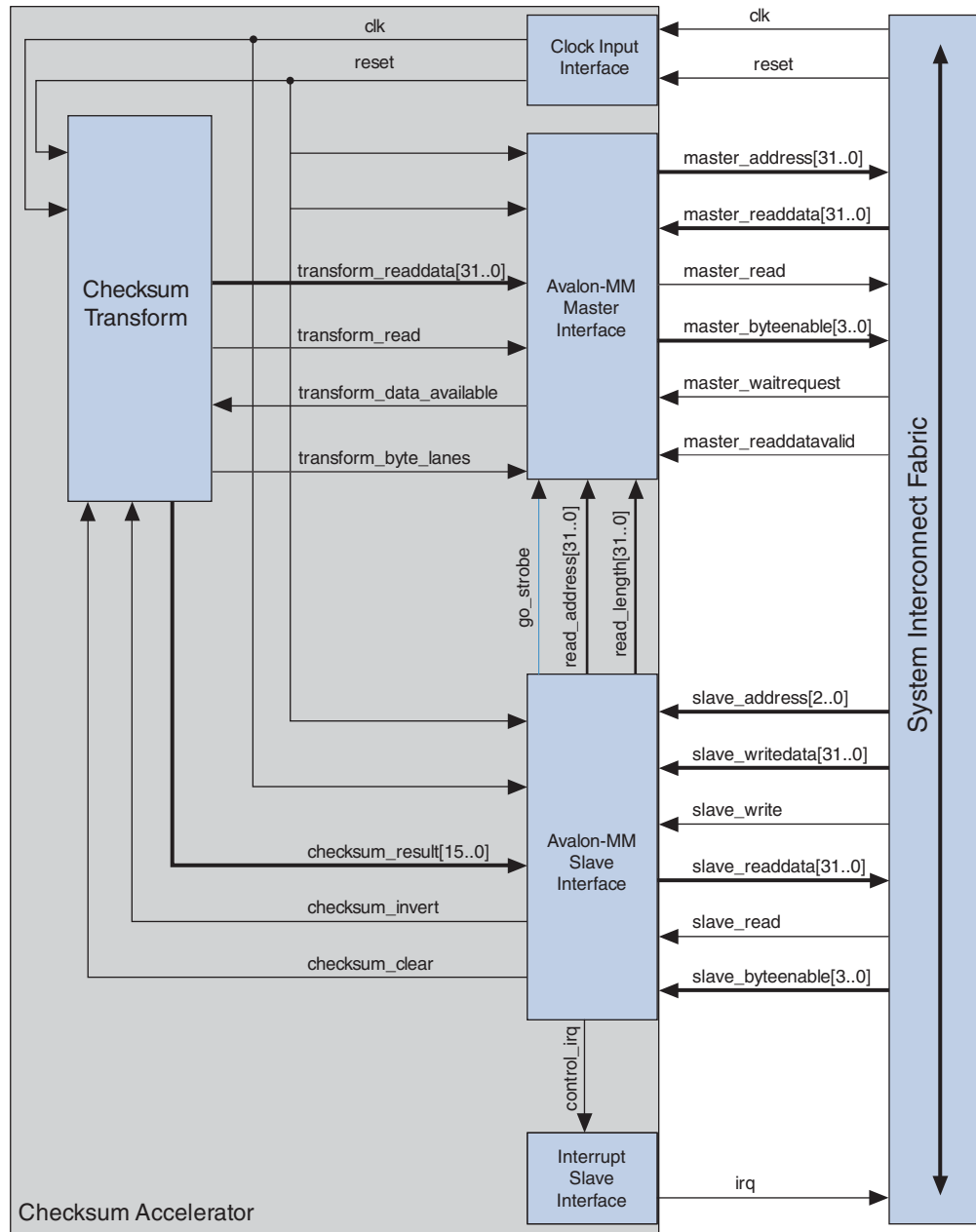

## Software Design

If you want a microprocessor to control your component, you must provide software files that define the software view of the component. At a minimum, you must define the register map for each Avalon-MM slave that is accessible to a processor.

 In the example checksum project, you can view an example of a software driver in the directory `<projectdir>/ip/checksum_accelerator`, which is the top level folder of the hardware and software for the custom checksum block.

Software drivers abstract hardware details of the component so that software can access the component at a high level. The driver functions provide the software an API to access the hardware. The software requirements vary according to the needs of the component. The most common types of routines initialize the hardware, read data, and write data.

When developing software drivers, you should review the software files provided for other ready-made components. The IP installer provides many components you can use as reference. You can also view the `<Nios II EDS install path>/components/` directory for examples.

 For details about writing drivers for the Nios II hardware abstraction layer (HAL), refer to the *Developing Device Drivers for the Hardware Abstraction Layer* chapter of the *Nios II Software Developer's Handbook*.

## Verifying the Component

You can verify the component in incremental stages, as you complete more of the design. You should first verify the hardware logic as a unit (which might consist of multiple smaller stages of verification) and later verify the component in a system.

### System Console

The system console is an interactive Tcl console available from within SOPC Builder that provides you with read and write access to the debugging capabilities that are available in your FPGA logic. You can use the system console to control and query the state of the Nios II processor, issue Avalon transactions, board bring-up, and access either JTAG UARTs or system level debug (SLD) nodes.

 For further details, refer to the *System Console User Guide*.

### System-Level Verification

After you package a `_hw.tcl` file with the component editor, you can instantiate the component in a system and verify the functionality of the overall SOPC Builder system.

SOPC Builder provides support for system-level verification for HDL simulators such as ModelSim®. SOPC Builder automatically produces a test bench for system-level verification.

-  You can include a Nios II processor in your system to enhance simulation capabilities during the verification phase. Even if your component has no relationship to the Nios II processor, the auto-generated ModelSim simulation environment provides an easy-to-use starting point.

## Sharing Components

When you create a component, component editor saves the `_hw.tcl` file in the same directory as the top-level HDL file. Where appropriate, files referenced by the `_hw.tcl` file are specified relative to the `_hw.tcl` file itself, so the files can easily be moved and copied. To share a component, include it in your IP library.

For more information about including components in an IP library refer to *Finding Components in SOPC Builder* in [Chapter 4, SOPC Builder Components](#).

## System Information Files (.sopcinfor)

Every time SOPC Builder generates a system, a `<mysystem>.sopcinfor` is also generated, which contains the following information:

- SOPC Builder project, including:
  - Name and tool version
  - HDL language
- Each module instantiated in the system, including:
  - Name and version
  - Where interface information was found on the disk, such as signal names and types, interface properties, and clock domain mapping
  - Parameter names and values
- Each connection, including:
  - Component and interface connections
  - Base address, Avalon-MM interfaces, IRQ number interfaces
  - Memory map as seen by each master in the system

-  The `.sopcinfor` file is a report file only, and cannot be edited with SOPC Builder.



You use bridges to control the topology of the generated SOPC Builder system. Bridges are not end-points for data, but rather affect the way data is transported between components. By inserting Avalon-MM bridges between masters and slaves, you control system topology, which in turn affects the interconnect that SOPC Builder generates. You can also use bridges to separate components in different clock domains and to implement clock domain crossing logic. Manual control of the interconnect can result in higher performance or lower logic utilization or both. Altera provides the following Avalon-MM bridges:

- “Avalon-MM Pipeline Bridge” on page 11–8
- “Clock Crossing Bridge” on page 11–12
- “Avalon-MM DDR Memory Half-Rate Bridge” on page 11–20

 For additional information on using bridges to optimize and control the topology of SOPC Builder systems, refer to *Avalon Memory-Mapped Design Optimizations* in the *Embedded Design Handbook*.

## Structure of a Bridge

A bridge has one Avalon-MM slave and one Avalon-MM master, as shown in Figure 11-1. In an SOPC Builder system, one or more masters connect to the bridge slave; in turn, the Avalon-MM bridge master connects to one or more slaves. In Figure 11-1, all three masters have logical connections to all three slaves, although physically each master only connects to the bridge.

**Figure 11-1. Example of an Avalon-MM Bridge in an SOPC Builder System**

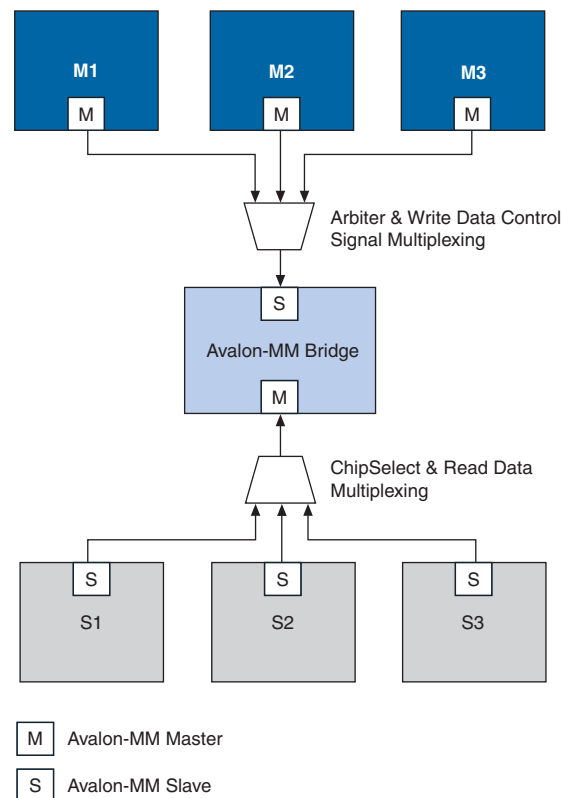

Transfers initiated to the bridge's slave propagate to the master in the same order in which they are initiated on the slave.

 For details on the Avalon-MM interface, refer to the [Avalon Interface Specifications](#).

## Reasons for Using a Bridge

When you have no bridges between master-slave pairs, SOPC Builder generates a system interconnect fabric with maximum parallelism, such that all masters can drive transactions to all slaves concurrently, as long as each master accesses a different slave. For systems that do not require a large degree of concurrency, the default behavior might not provide optimal performance. With knowledge of the system and application, you can optimize the system interconnect fabric by inserting bridges to control the system topology.

Figure 11-2 and Figure 11-3 show an SOPC system without bridges. This system includes three CPUs, a DDR SDRAM controller, a message buffer RAM, a message buffer mutex, and a tristate bridge to an external SRAM.

**Figure 11-2. Example System Without Bridges—SOPC Builder View**

Use	Connections	Module Name	Description	Base
<input checked="" type="checkbox"/>		<input type="checkbox"/> <b>cpu1</b>	Nios II Processor	
		instruction_master	Avalon Master	
		data_master	Avalon Master	IRQ 0
		jtag_debug_module	Avalon Slave	0x02002800
<input checked="" type="checkbox"/>		<input type="checkbox"/> <b>cpu2</b>	Nios II Processor	
		instruction_master	Avalon Master	
		data_master	Avalon Master	IRQ 0
		jtag_debug_module	Avalon Slave	0x00008000
<input checked="" type="checkbox"/>		<input type="checkbox"/> <b>cpu3</b>	Nios II Processor	
		instruction_master	Avalon Master	
		data_master	Avalon Master	IRQ 0
		jtag_debug_module	Avalon Slave	0x00001000
<input checked="" type="checkbox"/>		<input type="checkbox"/> <b>DDR_SDRAM_controller</b>	DDR SDRAM High Performance Control...	
		s1	Avalon Slave	0x01000000
<input checked="" type="checkbox"/>		<input type="checkbox"/> <b>message_buffer_RAM</b>	On-Chip Memory (RAM or ROM)	
	s1	Avalon Slave	0x02001000	
<input checked="" type="checkbox"/>	<input type="checkbox"/> <b>message_buffer_mutex</b>	Mutex		
	s1	Avalon Slave	0x02003000	
<input checked="" type="checkbox"/>	<input type="checkbox"/> <b>external_SSRAM_bus</b>	Avalon-MM Tristate Bridge		
	avalon_slave	Avalon Slave	0x00000000	
	tristate_master	Avalon Tristate Master		
<input checked="" type="checkbox"/>	<input type="checkbox"/> <b>external_SSRAM</b>	Cypress CY7C1380C SSRAM		
	s1	Avalon Tristate Slave	0xffffffff	

Figure 11-3 illustrates the default system interconnect fabric for the system in Figure 11-2.

**Figure 11-3. Example System without Bridges—System Interconnect View**

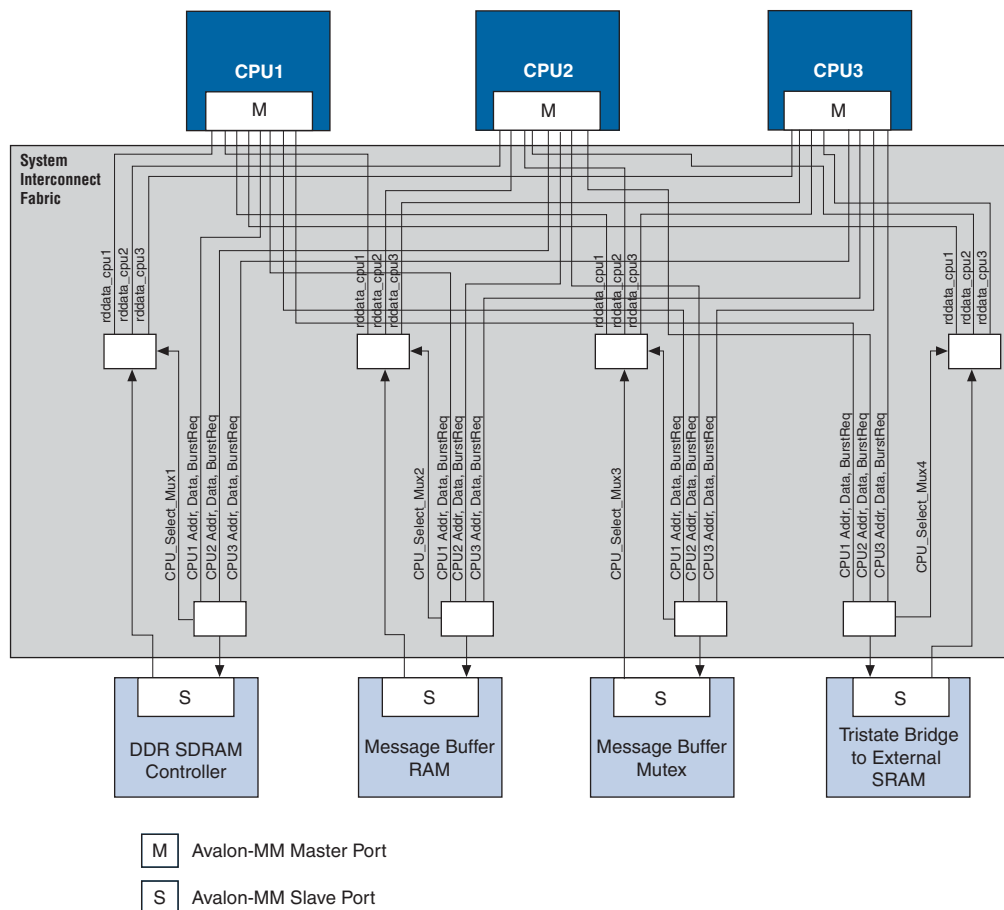

Figure 11-4 and Figure 11-5 show how inserting bridges can affect the generated logic. For example, if the DDR SDRAM controller can run at 166 MHz and the CPUs accessing it can run at 120 MHz, inserting an Avalon-MM clock-crossing bridge between the CPUs and the DDR SDRAM has the following benefits:

- Allows the CPU and DDR interfaces to run at different frequencies.
- Places system interconnect fabric for the arbitration logic and multiplexer for the DDR SDRAM controller in the slower clock domain.
- Reduces the complexity of the interconnect logic in the faster domain, allowing the system to achieve a higher  $f_{MAX}$ .



Inserting the clock-crossing bridge does increase read latency and may not be beneficial unless your system includes more devices that access the memory.



In the system illustrated in Figure 11-4, the message buffer RAM and message buffer mutex must respond quickly to the CPUs, but each response includes only a small amount of data. Placing an Avalon-MM pipeline bridge between the CPUs and the message buffers results in the following benefits:

- Eliminates separate arbiter logic for the message buffer RAM and message buffer mutex, which reduces logic utilization and propagation delay, thus increasing the  $f_{MAX}$ .
- Reduces the overall size and complexity of the system interconnect fabric.

Figure 11-4. Example SOPC System with Bridges—SOPC Builder View

Use	Connections	Module Name	Description	Clock	Base	End	IRQ
<input checked="" type="checkbox"/>		<input checked="" type="checkbox"/> <b>cpu1</b>	Nios II Processor				
		instruction_master	Avalon Master	clk			
		data_master	Avalon Master				
		jtag_debug_module	Avalon Slave		IRQ 0	IRQ 31	←×
<input checked="" type="checkbox"/>		<input checked="" type="checkbox"/> <b>cpu2</b>	Nios II Processor				
		instruction_master	Avalon Master	clk			
		data_master	Avalon Master		IRQ 0	IRQ 31	←×
		jtag_debug_module	Avalon Slave		0x03400800	0x03400fff	
<input checked="" type="checkbox"/>		<input checked="" type="checkbox"/> <b>cpu3</b>	Nios II Processor				
		instruction_master	Avalon Master	clk			
		data_master	Avalon Master		IRQ 0	IRQ 31	←×
		jtag_debug_module	Avalon Slave		0x03000800	0x03000fff	
<input checked="" type="checkbox"/>		<input checked="" type="checkbox"/> <b>bridge</b>	Avalon-MM Clock Crossing Bridge				
		s1	Avalon Slave	clk	0x03001000	0x030017ff	
		m1	Avalon Master		0x00000000	0x01ffffff	
<input checked="" type="checkbox"/>	<input checked="" type="checkbox"/> <b>ddr_sdram</b>	DDR SDRAM Controller MegaCore Fun...					
	s1	Avalon Slave	clk	0x00000000	0x01ffffff		
<input checked="" type="checkbox"/>	<input checked="" type="checkbox"/> <b>pipeline_bridge</b>	Avalon-MM Pipeline Bridge					
	s1	Avalon Slave	clk	0x02000000	0x02001fff		
	m1	Avalon Master					
<input checked="" type="checkbox"/>	<input checked="" type="checkbox"/> <b>message_buffer_ram</b>	On-Chip Memory (RAM or ROM)					
	s1	Avalon Slave	clk	0x00000000	0x00000fff		
<input checked="" type="checkbox"/>	<input checked="" type="checkbox"/> <b>message_buffer_mu...</b>	Mutex					
	s1	Avalon Slave	clk	0x00001000	0x00001007		
<input checked="" type="checkbox"/>	<input checked="" type="checkbox"/> <b>ext_ssram_bus</b>	Avalon-MM Tristate Bridge					
	avalon_slave	Avalon Slave	clk				
	tristate_master	Avalon Tristate Master					
<input checked="" type="checkbox"/>	<input checked="" type="checkbox"/> <b>ext_ssram</b>	Cypress CY7C1380C SSRAM					
	s1	Avalon Tristate Slave	clk	0x03200000	0x033fffff		

If an orange triangle appears next to an address in Figure 11-4, it indicates that the address is an offset value and is not the true value of the address in the address map.

Figure 11-5 shows the system interconnect fabric that SOPC Builder creates for the system in Figure 11-4. Figure 11-5 is the same system that is pictured in Figure 11-3 with bridges to control system topology.

**Figure 11-5. Example System with a Bridge**

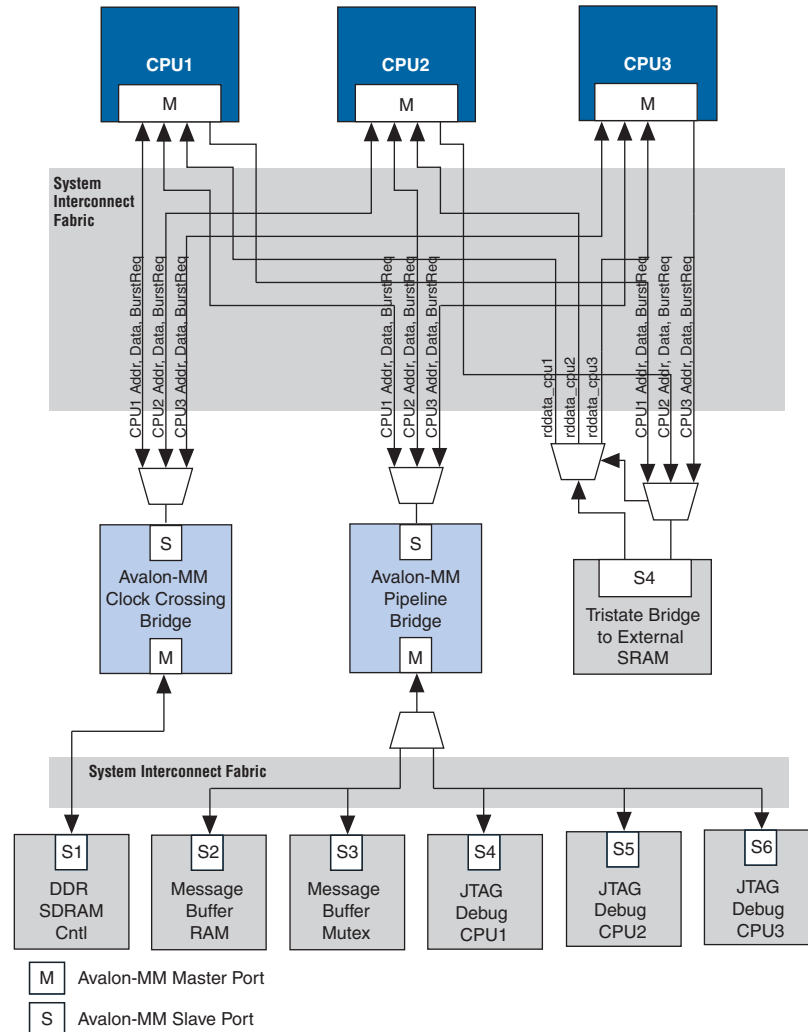

## Address Mapping for Systems with Avalon-MM Bridges

An Avalon-MM bridge has an address span and range that are defined as follows:

- The address *span* of an Avalon-MM bridge is the smallest power-of-two size that encompasses all of its slave's ranges.

- The address *range* of an Avalon-MM bridge is a numerical range from its base address to its base address plus its (span -1).

**Equation 11-1.**

$$range = [base\_address .. (base\_address + (span - 1))];$$

SOPC Builder follows several rules in constructing an address map for a system with Avalon-MM bridges:

1. The address span of each Avalon-MM slave is rounded up to the nearest power of two.
2. Each Avalon-MM slave connected to a bridge has an address relative to the base address of the bridge. This address must be a multiple of its span. (See [Figure 11-6.](#))

**Figure 11-6. Avalon-MM Master and Slave Addresses**

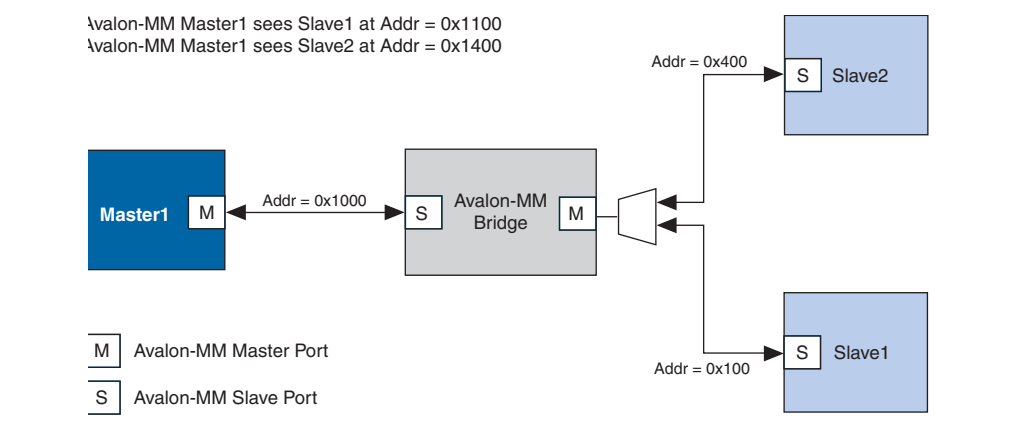

3. In the example shown in [Figure 11-6](#), if the address span of Slave 1 is 0x100 and the address span of Slave 2 is 0x200, [Figure 11-7](#) illustrates the address span of the Avalon-MM bridge.

**Figure 11-7. The Address Span of an Avalon-MM Bridge**

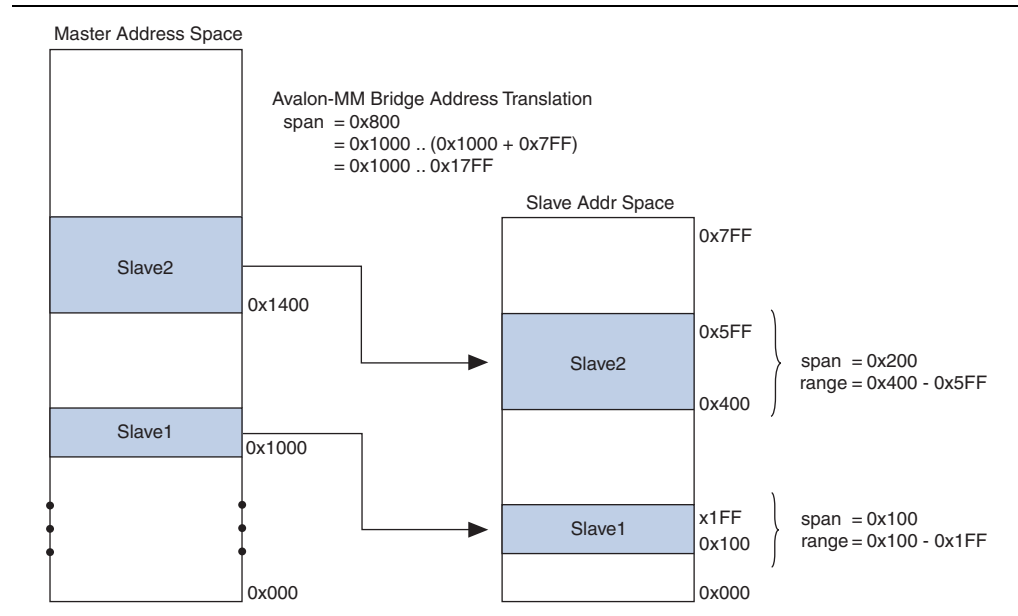

### Tools for Visualizing the Address Map

The **Base Address** column of the **System Contents** tab displays the base address *offset* of the Avalon-MM slave relative to the base address of the Avalon-MM bridge to which it is connected. You can see the absolute address map for each master in the system by clicking **Address Map** on the **System Contents** tab.

### Differences between Avalon-MM Bridges and Avalon-MM Tristate Bridges

You use Avalon-MM bridges to control topology and separate clock domains for on-chip components. You use tristate bridges to connect to off-chip components and to share pins, decreasing the overall pin count of the device. Tristate bridges are *transparent*, meaning that they do not affect the addresses of the components to which they connect.



For more information about the Avalon-MM tristate bridge, refer to [Chapter 9, SOPC Builder Memory Subsystem Development Walkthrough](#).

## Avalon-MM Pipeline Bridge

This section describes the hardware structure and functionality of the Avalon-MM pipeline bridge component.

## Component Overview

The Avalon-MM pipeline bridge inserts registers in the path between its master and slaves. In a given SOPC Builder system, if the critical register-to-register delay occurs in the system interconnect fabric, the pipeline bridge can help reduce this delay and improve system  $f_{MAX}$ .

The bridge allows you to independently pipeline different groups of signals that can create a critical timing path in the interconnect:

- Master-to-slave signals, such as address, write data, and control signals
- Slave-to-master signals, such as read data
- The `waitrequest` signal to the master



You can also use the Avalon-MM pipeline bridge to control topology without adding a pipeline stage. To instantiate a bridge that does not add any pipeline stages, simply do not select any of the **Pipeline Options** on the parameter page. For the system illustrated in [Figure 11-5](#), a pipeline bridge that does not add a pipeline register stage is optimal because the CPUs benefit from minimal delay from the message buffer mutex and message buffer RAM.



A pipeline bridge with no latency cannot be used with slaves that support pipelined reads. If a slave does not have read latency, you cannot connect it to a bridge with no pipeline stages, because the pipeline bridge slave port has a `readdatavalid` signal. Pipelined read components cannot have zero read latency. Some examples of 0 latency components available in SOPC Builder include the UART, Timer and SPI core. You are connecting a pipeline bridge to one of these components, increase the read latency from 0 to 1.

The Avalon-MM pipeline bridge component integrates easily into any SOPC Builder system.

## Functional Description

Figure 11-8 shows a block diagram of the Avalon-MM pipeline bridge component.

**Figure 11-8. Avalon-MM Pipeline Bridge Block Diagram**

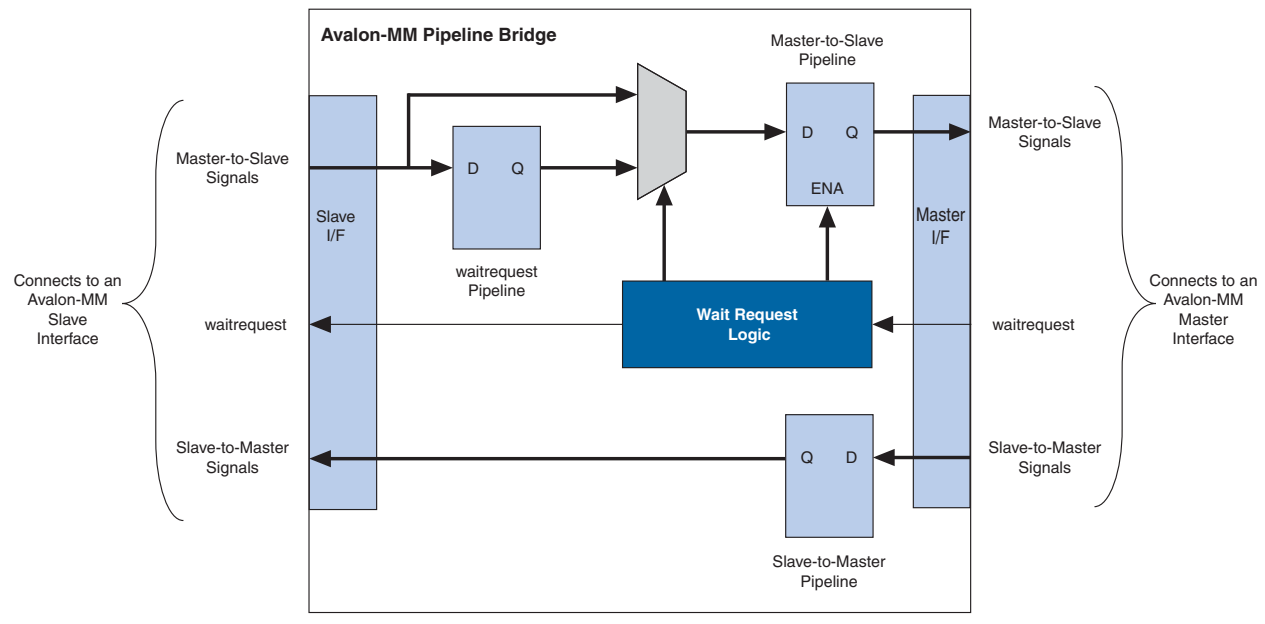

The following sections describe the component's hardware functionality.

### Interfaces

The bridge interface is composed of an Avalon-MM slave and an Avalon-MM master. The data width of the ports is configurable, which can affect how SOPC Builder generates dynamic bus sizing logic in the system interconnect fabric. Both ports support Avalon-MM pipelined transfers with variable latency. Both ports optionally support bursts of lengths that you can configure.

### Pipeline Stages and Effects on Latency

The bridge provides three optional register stages to pipeline the following groups of signals.

- Master-to-slave signals, including:
  - address
  - writedata
  - write
  - read
  - byteenable
  - chipselect
  - burstcount (optional)

- Slave-to-master signals, including:
  - `readdata`
  - `readdatavalid`
- The `waitrequest` signal to the master

When you include a register stage, it affects the timing and latency of transfers through the bridge, as follows:

- The latency increases by one cycle in each direction.
- Write transfers on the master side of the bridge are decoupled from write transfers on the slave side of the bridge because Avalon-MM write transfers do not require an acknowledge signal from the slave.
- Including the `waitrequest` register stage increases the latency of master-to-slave signals by one additional cycle when the `waitrequest` signal is asserted.

### **Burst Support**

The bridge can support bursts with configurable maximum burst length. When configured to support bursts, the bridge propagates bursts between master-slave pairs, up to the maximum burst length. Not having burst support is equivalent to a maximum burst length of one. In this case, the system interconnect fabric automatically decomposes master-to-bridge bursts into a sequence of individual transfers.

## Example System with Avalon-MM Pipeline Bridges

Figure 11-9 illustrates a system in which seven Avalon-MM masters are accessing a single DDR2 memory controller. By inserting two Avalon-MM pipeline bridges, you can limit the complexity of the multiplexer that would be required.

Figure 11-9. Seven Avalon-MM Masters Accessing One Avalon-MM Slave

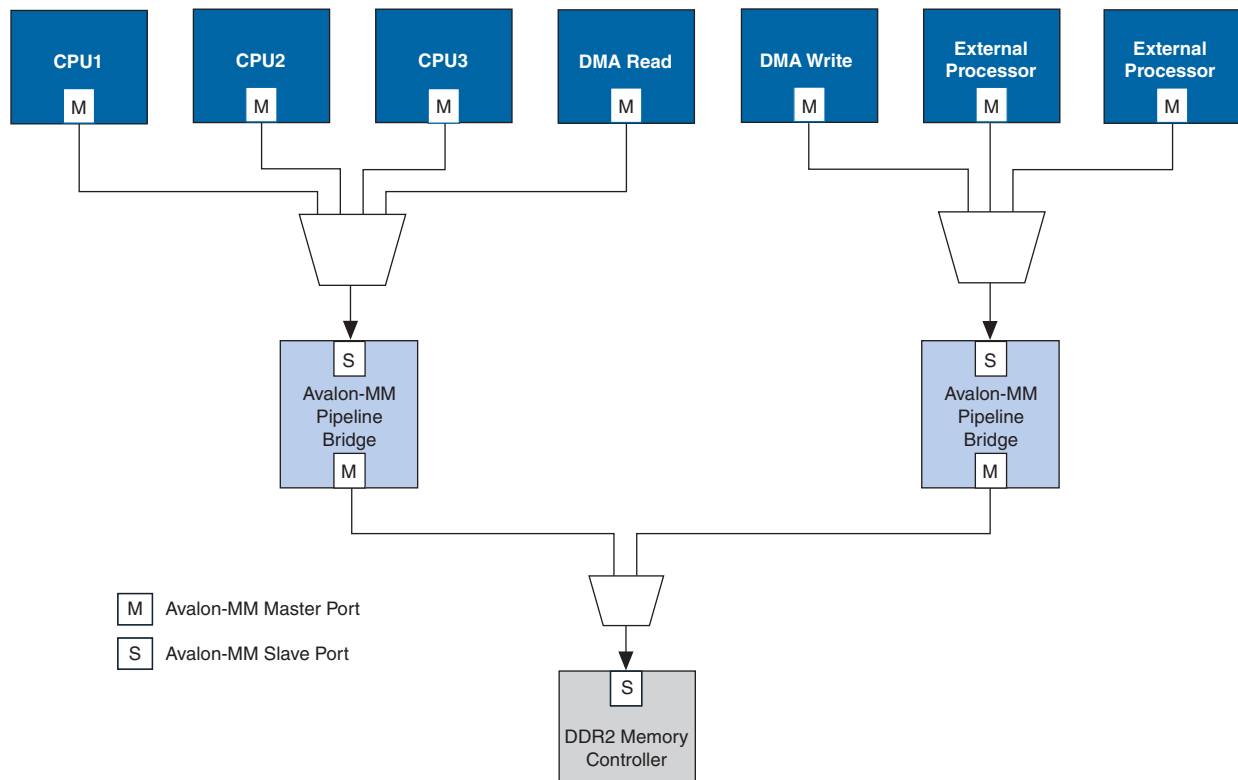

## Clock Crossing Bridge

The Avalon-MM clock-crossing bridge allows you to connect Avalon-MM master and slaves that operate in different clock domains. Without a bridge, SOPC Builder automatically includes generic clock domain crossing (CDC) logic in the system interconnect fabric, but it does not provide optimal performance for high-throughput applications. Because the clock-crossing bridge includes a buffering mechanism, you can pipeline multiple read and write transfers. After an initial penalty for the first read or write, there is no additional latency penalty for pending reads and writes, increasing throughput at the expense primarily of on-chip memory. The clock-crossing bridge has parameterizable FIFOs for master-to-slave and slave-to-master signals, and allows burst transfers across clock domains.

The Avalon-MM clock-crossing bridge component is SOPC Builder-ready and integrates easily into any SOPC Builder-generated system.



## Choosing Clock Crossing Methodology

When determining clock frequencies for your components, you should also consider the impact on the latency that transferring data across clock domains can cause. Whether you use a clock-crossing bridge or rely on the clock domain adapter created automatically by SOPC Builder, additional latency occurs. You should also consider the resource usage and throughput capabilities of each solution.

If you rely on the automatically generated clock crossing adapter to connect master and slave ports driven by separate clock inputs, there is a fixed latency penalty associated to each transfer. Each transfer becomes blocking, meaning that while one transfer is underway another cannot begin until the first completes. For this reason, you should not connect high-speed, pipelined components such as SDRAM memory to a master on a different clock domain without using a clock-crossing bridge between them. The clock crossing bridge, on the other hand, can queue multiple transfers, so that even though the latency increases, the throughput does not decrease.

Because a clock crossing adapter is generated for every master and slave pair, you should use a clock crossing bridge if your design contains multiple master and slave pairs operating in different clock domains. Alternatively, if your design uses a large amount of on-chip memory, you may need to use a clock domain adapter, because the clock-crossing bridge uses on-chip memory resources for buffering.

## Functional Description

Figure 11-10 shows a block diagram of the Avalon-MM clock-crossing bridge component. The following sections describe the component's hardware functionality.

Figure 11-10. Avalon-MM Clock-Crossing Bridge Block Diagram

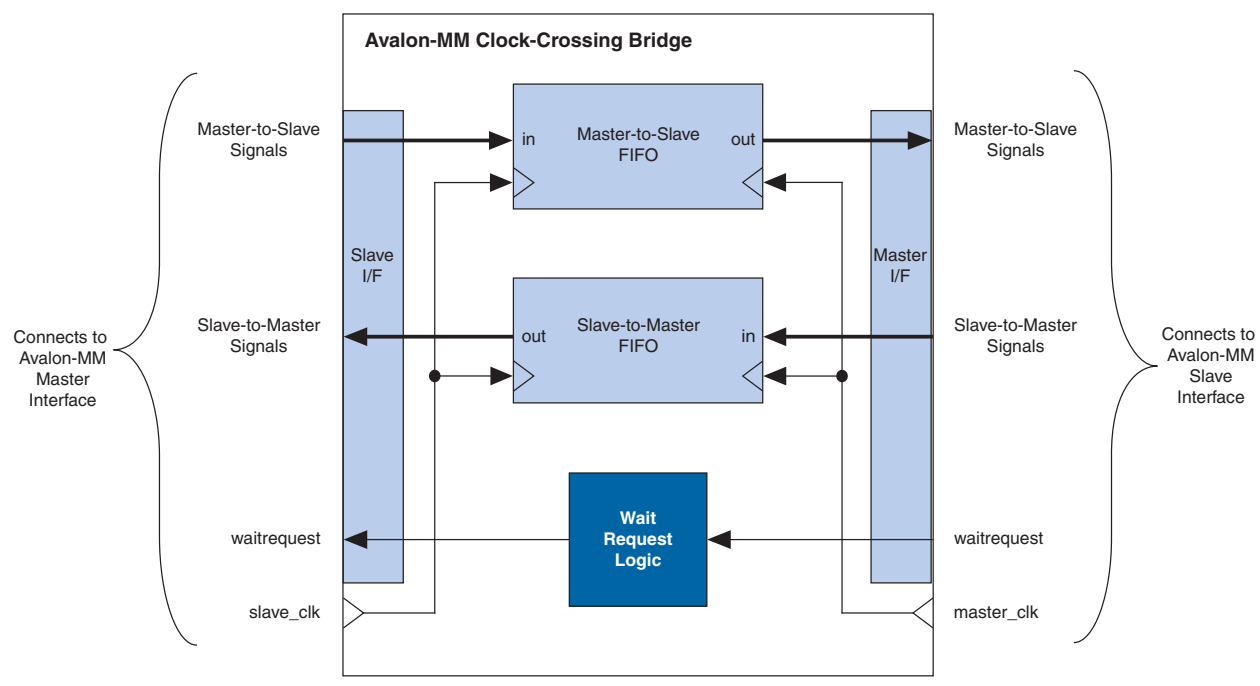

## Interfaces

The bridge interface comprises an Avalon-MM slave and an Avalon-MM master. The data width of the ports is configurable, which affects the size of the bridge hardware and how SOPC Builder generates dynamic bus sizing logic in the system interconnect fabric. Both ports support Avalon-MM pipelined transfers with variable latency. Both ports optionally support bursts of user-configurable length. Ideally, the settings for one port match the other, such that there are no mixed data widths or bursting capabilities.

## Clock Crossing Bridge and FIFOs

Two FIFOs in the bridge transport address, data, and control signals across the clock domains. One FIFO captures data and controls traveling in the master-to-slave direction, and the other FIFO captures data in the slave-to-master direction. Clock crossing logic surrounding the FIFOs coordinates the details of passing data across the clock-domain boundaries and ensures that the FIFOs do not overflow or underflow.

The signals that pass through the master-to-slave FIFO include:

- `writedata`
- `address`
- `read`
- `write`
- `byteenable`
- `burstcount`, when bursting is enabled

The signals that pass through the slave-to-master FIFO include:

- `readdata`
- `readdatavalid`

You can configure the depth of each FIFO. Because there are more signals traveling in the master-to-slave direction, changing the depth of the master-to-slave FIFO has a greater impact on the memory utilization of the bridge.

For read transfers across the bridge, the FIFOs in both directions incur latency for data to return from the slave. To avoid paying a latency penalty for each transfer, the master can issue multiple reads that are queued in the FIFO. The slave of the bridge asserts `readdatavalid` when it drives valid data and asserts `waitrequest` when it is not ready to accept more reads.

For write transfers, the master-to-slave FIFO causes a delay between the master-to-bridge transfers and the corresponding bridge-to-slave transfers. Because Avalon-MM write transfers do not require an acknowledge from the slave, multiple write transfers from master-to-bridge might complete by the time the bridge initiates the corresponding bridge-to-slave transfers.

## Burst Support

The bridge optionally supports bursts with configurable maximum burst length. When configured to support bursts, the bridge propagates bursts between master-slave pairs, up to the maximum burst length. Not having burst support is equivalent to a maximum burst length of one. In this case, the system interconnect fabric automatically breaks master-to-bridge bursts into a sequence of individual transfers.

When you configure the bridge to support bursts, you must configure the slave-to-master FIFO depth deeply enough to capture all burst read data without overflowing. The masters connected to the bridge could potentially fill the master-to-slave FIFO with read burst requests; therefore, the minimum slave-to-master FIFO depth is described by equation given in [Example 11-1](#).

### Example 11-1. Minimum Slave-To-Master FIFO Depth

---

$$= ((\text{master-to-slave FIFO depth}) * (\text{max burst length})) + \text{max slave latency/pending reads}$$

---

### Example System with Avalon-MM Clock-Crossing Bridges

Figure 11-11 uses Avalon-MM clocking crossing bridges to separate slave components into two groups. The low-performance slave components are placed behind a single bridge and clocked at a low speed. The high performance components are placed behind a second bridge and clocked at a higher speed. By inserting clock-crossing bridges in the system, you optimize the interconnect fabric and allow the Quartus® II fitter to expend effort optimizing paths that require minimal propagation delay.

**Figure 11-11. One Avalon-MM Master with Two Groups of Avalon-MM Slaves**

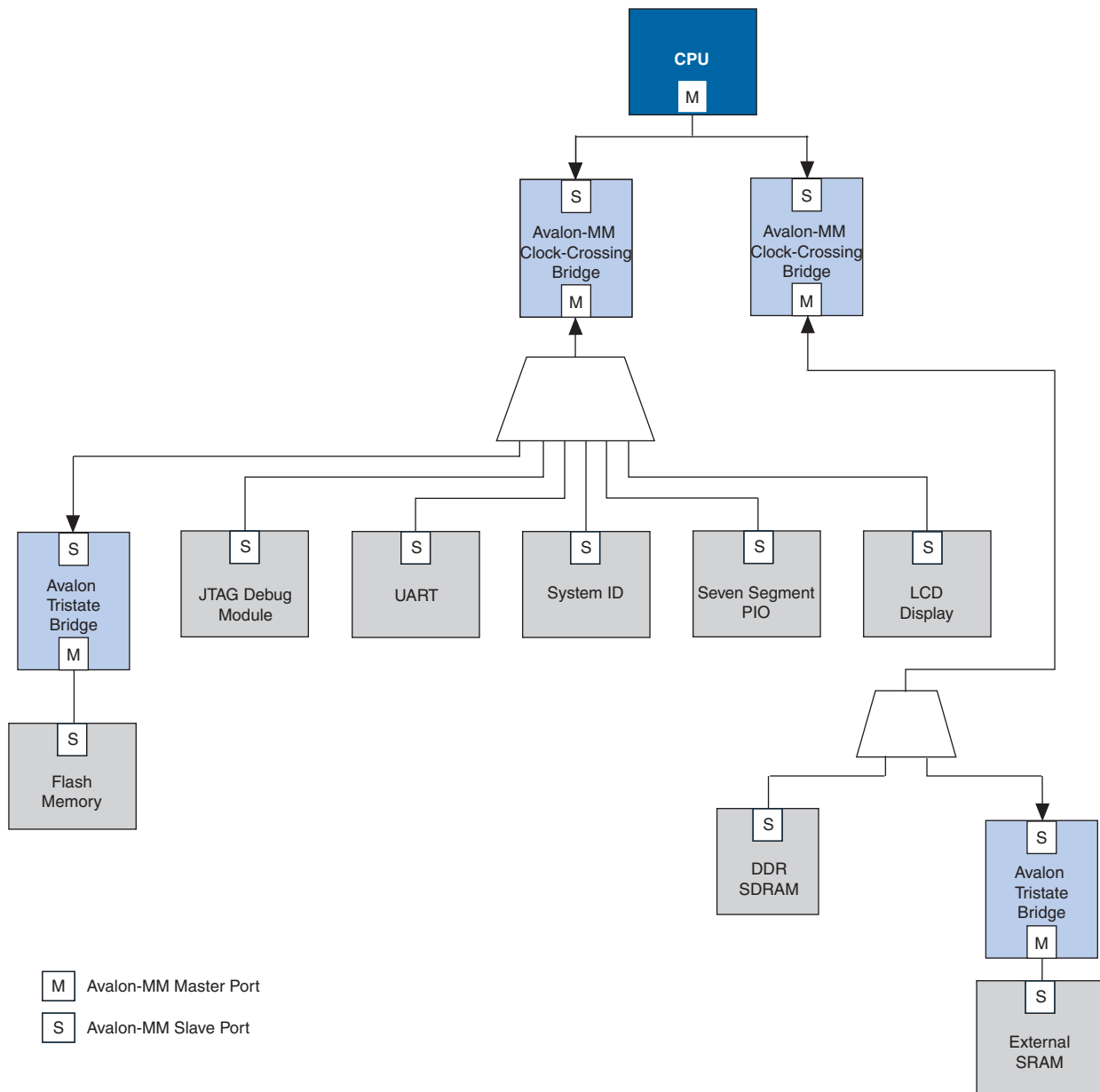

## Instantiating the Avalon-MM Clock-Crossing Bridge in SOPC Builder

Table 11-1 describes the options available on the **Parameter Settings** page of the .

**Table 11-1. Avalon-MM Clock Crossing Bridge Parameters**

<b>Master-to-slave FIFO</b>		
<b>Parameter</b>	<b>Value</b>	<b>Description</b>
<b>FIFO depth</b>	<b>8, 16, 32</b>	Determines the depth of the FIFO.
<b>Construct FIFO with registers instead of memory blocks</b>	<b>On/Off</b>	When you turn on this option, the FIFO uses registers as storage instead of embedded memory blocks. This can considerably increase the size of the bridge hardware and lower the $f_{MAX}$ .
<b>Slave-to-master FIFO</b>		
<b>FIFO depth</b>	<b>8, 16, 32, 64, 128, 256, 512, 1024</b>	Determines the depth of the FIFO.
<b>Construct FIFO with registers instead of memory blocks</b>	<b>On/Off</b>	When you turn on this option, the FIFO uses registers as storage instead of embedded memory blocks. This can considerably increase the size of the bridge hardware and lower the $f_{MAX}$ .
<b>Common options</b>		
<b>Data width</b>	<b>8, 16, 32, 64, 128, 256, 512, 1024</b>	Determines the data width of the interfaces on the bridge, and affects the size of both FIFOs. For the highest bandwidth, set <b>Data width</b> to be as wide as the widest master connected to the bridge.
Slave domain synchronizer length	2-8	The number of pipeline stages in the clock crossing logic in the issuing master to target slave direction. Increasing this value leads to a larger meantime between failures (MTBF). You can determine the MTBF for a given design can be determined by running a TimeQuest timing analysis.
Master domain synchronizer length	2-8	The number of pipeline stages in the clock crossing logic in the issuing master to target slave direction. Increasing this value leads to a larger meantime between failures (MTBF). You can determine the MTBF for a given design can be determined by running a TimeQuest timing analysis.
<b>Burst settings</b>		
<b>Allow bursts</b>	<b>On/Off</b>	Includes logic for the bridge's master and slaves to support bursts. You can use this option to restrict the minimum depth for the slave-to-master FIFO.
<b>Maximum burst size</b>	<b>2, 4, 8, 16, 32, 64, 128, 256, 512, 1024</b>	Determines the maximum length of bursts for the bridge to support, when you turn on <b>Allow bursts</b> .

## Clock Domain Crossing Logic

SOPC Builder generates CDC logic that hides the details of interfacing components operating in different clock domains. The system interconnect fabric upholds the Avalon-MM protocol with each port independently, and therefore masters do not need to incorporate clock adapters in order to interface to slaves on a different domain. The system interconnect fabric logic propagates transfers across clock domain boundaries automatically.

The clock-domain adapters in the system interconnect fabric provide the following benefits that simplify system design efforts:

- Allow component interfaces to operate at different clock frequencies.
- Eliminate the need to design CDC hardware.
- Allow each Avalon-MM port to operate in only one clock domain, which reduces design complexity of components.
- Enable masters to access any slave without communication with the slave clock domain.
- Allow you to focus performance optimization efforts only on components that require fast clock speed.

## Description of Clock Domain Adapter

The clock domain adapter consists of two finite state machines (FSM), one in each clock domain, that use a simple hand-shaking protocol to propagate transfer control signals (`read_request`, `write_request`, and the master `waitrequest` signals) across the clock boundary. [Figure 11-12](#) shows a block diagram of the clock domain adapter between one master and one slave.

**Figure 11-12. Block Diagram of Clock Crossing Adapter**

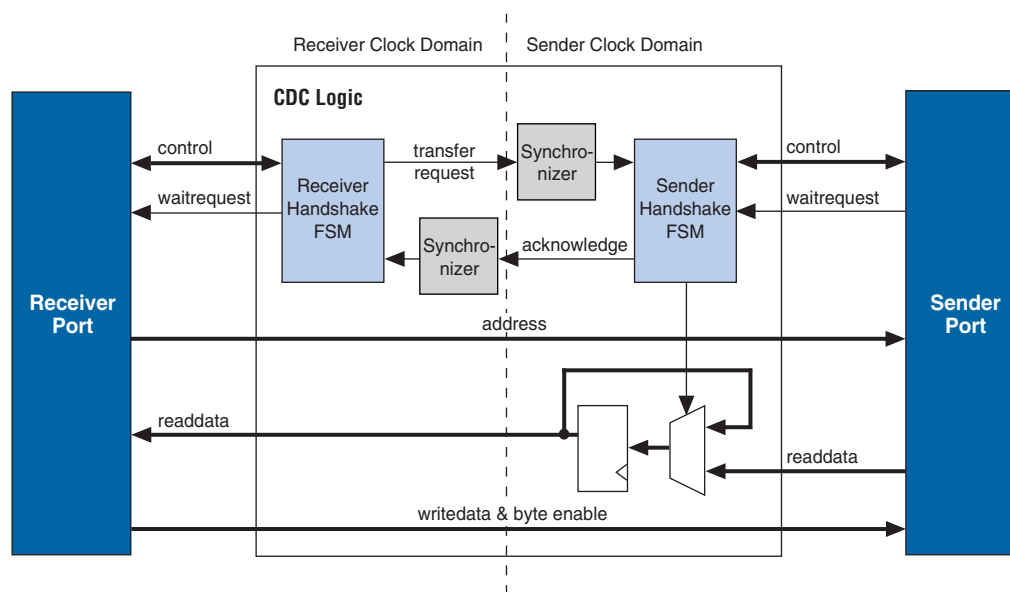

The synchronizer blocks in [Figure 11-12](#) use multiple stages of flipflops to eliminate the propagation of metastable events on the control signals that enter the handshake FSMs.

The CDC logic works with any clock ratio. Altera tests the CDC logic extensively on a variety of system architectures, both in simulation and in hardware, to ensure that the logic functions correctly.

The typical sequence of events for a transfer across the CDC logic is described as follows:

1. Master asserts address, data, and control signals.
2. The master handshake FSM captures the control signals, and immediately forces the master to wait.



The FSM uses only the control signals, not address and data. For example, the master simply holds the address signal constant until the slave side has safely captured it.

3. Master handshake FSM initiates a transfer request to the slave handshake FSM.
4. The transfer request is synchronized to the slave clock domain.
5. The slave handshake FSM processes the request, performing the requested transfer with the slave.
6. When the slave transfer completes, the slave handshake FSM sends an acknowledge back to the master handshake FSM.
7. The acknowledge is synchronized back to the master clock domain.
8. The master handshake FSM completes the transaction by releasing the master from the wait condition.

Transfers proceed as normal on the slave and the master side, without a special protocol to handle crossing clock domains. From the perspective of a slave, there is nothing different about a transfer initiated by a master in a different clock domain. From the perspective of a master, a transfer across clock domains simply requires extra clock cycles. Similar to other transfer delay cases (for example, arbitration delay or wait states on the slave side), the system interconnect fabric simply forces the master to wait until the transfer terminates. As a result, pipeline master ports do not benefit from pipelining when performing transfers to a different clock domain.

## Location of Clock Domain Adapter

You can use the clock crossing bridge described in the following paragraphs for higher throughput clock crossing, at the expense of memory resources.

SOPC Builder automatically determines where to insert the CDC logic, based on the system contents and the connections between components. SOPC Builder places CDC logic to maintain the highest transfer rate for all components. SOPC Builder evaluates the need for CDC logic for each master and slave pair independently, and generates CDC logic wherever necessary.

## Duration of Transfers Crossing Clock Domains

CDC logic extends the duration of master transfers across clock domain boundaries. In the worst case which is for reads, each transfer is extended by five master clock cycles and five slave clock cycles. Assuming the default value of 2 for the **Master domain synchronizer length** and the **Slave domain synchronizer length**, the components of this delay are the following:

- Four additional master clock cycles, due to the master-side clock synchronizer
- Four additional slave clock cycles, due to the slave-side clock synchronizer

- One additional clock in each direction, due to potential metastable events as the control signals cross clock domains



Systems that require a higher performance clock should use the Avalon-MM clock crossing bridge instead of the automatically inserted CDC logic. The clock crossing bridge includes a buffering mechanism, so that multiple reads and writes can be pipelined. After paying the initial penalty for the first read or write, there is no additional latency penalty for pending reads and writes, increasing throughput by up to four times, at the expense of added logic resources.



For more information, refer to [Chapter 3, System Interconnect Fabric for Streaming Interfaces](#) and [Avalon Memory-Mapped Design Optimizations](#) in the *Embedded Design Handbook*.

## Implementing Multiple Clock Domains in SOPC Builder

You specify the clock domains used by your system on the **System Contents** tab of SOPC Builder. You define the input clocks to the system with the **Clock Settings** table. Clock sources can be driven by external input signals to the SOPC Builder system or by PLLs inside the SOPC Builder system. Clock domains are differentiated based on the name of the clock. You may create multiple asynchronous clocks with the same frequency.

To specify which clock drives which components you must display the **Clock** column in the **System Contents** tab. By default, clock names are not displayed. To display clock names in the **Module Name** column and the clocks in the **Clock** column in the **System Contents** tab, right-click in the **Module Name** column and click **Show All**. To connect a clock to follow these steps.

1. Click in the **Clock** column next to the clock port. A list of available clock signals appears.
2. Select the appropriate signal from the list of available clocks. [Figure 11-13](#) illustrates this step.

**Figure 11-13. Assigning Clocks to Components**

Module Name	Description	Clock	Base	End	IRQ
high_res_timer	Interval timer	clk	0x02120820	0x0212083F	3
seven_seg_pio	PIO (Parallel I/O)	clk	0x02120890	0x0212089F	
reconfig_request_pio	PIO (Parallel I/O)	fastclk	0x021208A0	0x021208AF	
uart1	UART (RS-232 serial port)	clk	0x02120840	0x0212085F	4
sysid	System ID Peripheral	clk	0x021208B8	0x021208BF	
sdram	SDRAM Controller	clk	0x01000000	0x01FFFFFF	
dma_0	DMA	fastclk	0x00800000	0x0080001F	7
read_buffer	On-Chip Memory (RAM ...)	fastclk	0x00801000	0x00801FFF	
write_buffer	On-Chip Memory (RAM ...)	fastclk	0x00802000	0x00802FFF	

## Avalon-MM DDR Memory Half-Rate Bridge

The Avalon Memory-Mapped (MM) Half-Rate Bridge core is a special-purpose clock-crossing bridge intended for CPUs that require low-latency access to high-speed memory. The core works under the assumption that the memory clock is twice the frequency of the CPU clock, with zero phase shift between the two. It allows high speed memory to run at full rate while providing low-latency interface for a CPU to



access it by using lightweight logic that translates one single-word request into a two-word burst to a memory running at twice the clock frequency and half the width. For systems with a 8-bit DDR interface, using the Half-Rate DDR Bridge in conjunction with a DDR SDRAM high-performance memory controller creates a datapath that matches the throughput of the DDR memory to the CPU. This half-rate bridge provides the same functionality as the clock crossing bridge, but with significantly lower latency—2 cycles instead of 12.

The core's master interface is designed to be connected to a high-speed DDR SDRAM controller and thus only supports bursting. Because the slave interface is designed to receive single-word requests, it does not support bursting. Figure 11-14 shows a system including an 8-bit DDR memory, a high-performance memory controller, the Half-Rate DDR Bridge, and a CPU.

**Figure 11-14. SOPC Builder Memory System Using a DDR Memory Half-Rate Bridge**

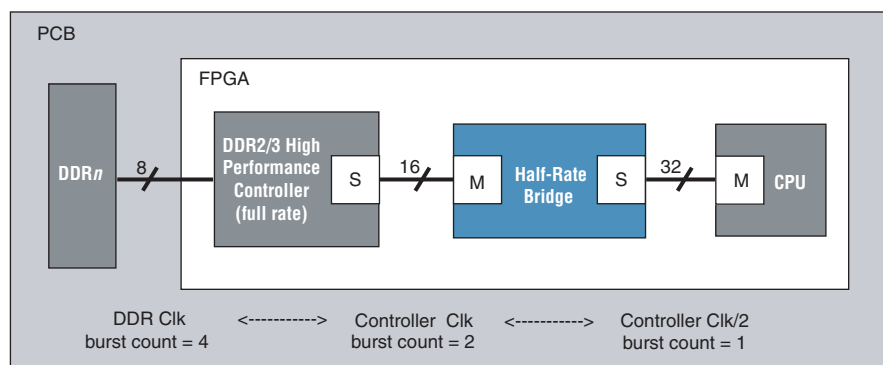

The Avalon-MM DDR Memory Half-Rate Bridge core has the following features and requirements:

- SOPC Builder ready with TimeQuest Timing Analyzer constraints
- Requires master clock and slave clock to be synchronous
- Handles different bus sizes between CPU and memory
- Requires the frequency of the master clock to be double of the slave clock
- Has configurable address and data port widths in the master interface

## Resource Usage and Performance

This section lists the resource usage and performance data for supported devices when operating the Half-Rate Bridge with a full-rate DDR SDRAM high-performance memory controller.

Using the Half-Rate Bridge with a full-rate DDR SDRAM high-performance memory controller results an average of 48% performance improvement over a system using a half-rate DDR SDRAM high-performance memory controller in a series of embedded applications. The performance improvement is 62.2% based on the Dhrystone benchmark, and 87.7% when accessing memory bypassing the cache. For memory systems that use the Half-Rate bridge in conjunction with DDR2/3 High Performance Controller, the data throughput is the same on the Half-Rate Bridge master and slave interfaces. The decrease in memory latency on the Half-Rate Bridge slave interface results in higher performance for the processor.

Table 11-2 shows the resource usage for Stratix® II and Stratix III devices in version 9.1 of the Quartus II software with a data width of 16 bits, an address span of 24 bits.

**Table 11-2. Resource Utilization Data for Stratix II and Stratix III Devices**

Device Family	Combinational ALUTs	ALMs	Logic Register	Embedded Memory
Stratix II	61	134	153	0
Stratix III	60	138	153	0

Table 11-3 lists the resource usage for a Cyclone® III device.

**Table 11-3. Resource Utilization Data for Cyclone III Devices**

Logic Cells (LC)	Logic Register	LUT-only LC	Register-only LC	LUT/Register LCs	Embedded Memory
233	152	33	84	121	0

## Functional Description

The Avalon MM DDR Memory Half Rate Bridge works under two constraints:

- Its memory-side master has a clock frequency that is synchronous (zero phase shift) to, and twice the frequency of, the CPU-side slave.
- Its memory-side master is half as wide as its CPU-side slave.

The bridge leverages these two constraints to provide lightweight, low-latency clock-crossing logic between the CPU and the memory. These constraints are in contrast with the Avalon-MM Clock-Crossing Bridge, which makes no assumptions about the frequency/phase relationship between the master- and slave-side clocks, and provides higher-latency logic that fully-synchronizes all signals that pass between the two domains.

The Avalon MM DDR Memory Half-Rate Bridge has an Avalon-MM slave interface that accepts single-word (non-bursting) transactions. When the slave interface receives a transaction from a connected CPU, it issues a two-word burst transaction on its master interface (which is half as wide and twice as fast). If the transaction is a read request, the bridge's master interface waits for the slave's two-word response, concatenates the two words, and presents them as a single readdata word on its slave interface to the CPU. Every time the data width is halved, the clock rate is doubled. As a result, the data throughput is matched between the CPU and the off-chip memory device.

Figure 11-15 shows the latency in the Avalon-MM Half-Rate Bridge core. The core adds two cycles of latency in the slave clock domain for read transactions. The first cycle is introduced during the command phase of the transaction and the second cycle, during the response phase of the transaction. The total latency is  $2 + \langle x \rangle$ , where  $\langle x \rangle$  refers to the latency of the DDR SDRAM high-performance memory controller. Using the clock crossing bridge for this same purpose would impose approximately 12 cycles of additional latency.

**Figure 11-15. Avalon-MM DDR Memory Half-Rate Bridge Block Diagram**

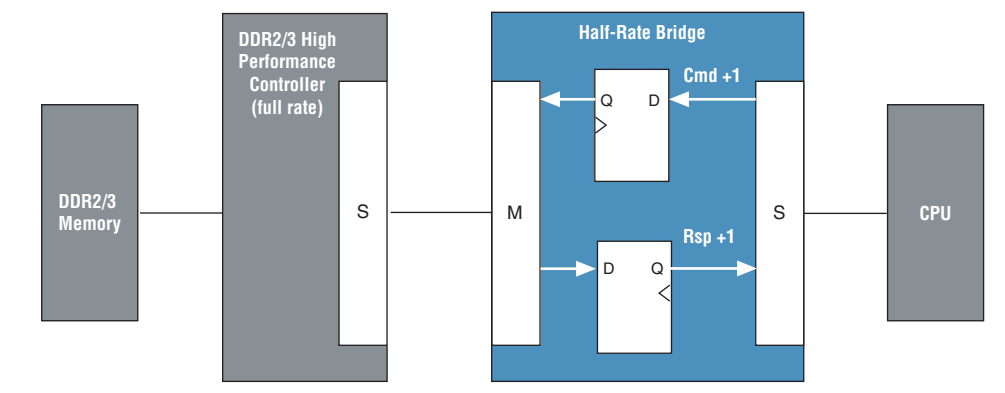

## Instantiating the Core in SOPC Builder

Use the MegaWizard Plug-In Manager for the Avalon-MM Half-Rate Bridge core in SOPC Builder to specify the core's configuration. Table 11-4 describes the parameters that can be configured for the Avalon-MM Half-Rate Bridge core.

**Table 11-4. Configurable Parameters for Avalon-MM DDR Memory Half-Rate Bridge Core**

Parameters	Value	Description
Data Width	8, 16, 32, 64, 128, 256, 512	The width of the data signal in the master interface.
Address Width	1 - 32	The width of the address signal in the master interface.

Table 11-5 describes the parameters that are derived based on the Data Width and Address Width settings for the Avalon-MM Half-Rate Bridge core.

**Table 11-5. Derived Parameters for Avalon-MM DDR Memory Half-Rate Bridge Core**

Parameter	Description
Master interface's Byte Enable Width	The width of the byte-enable signal in the master interface.
Slave interface's Data Width	The width of the data signal in the slave interface.
Slave interface's Address Width	The width of the address signal in the slave interface.
Slave interface's Byte Enable Width	The width of the byte-enable signal in the slave interface.

## Example System

The following example provides high-level steps showing how the Avalon-MM DDR Memory Half-Rate Bridge core is connected in a system. This example assumes that you are familiar with the SOPC Builder GUI.



For a quick introduction to this tool, read of the one-hour online course, *Using SOPC Builder*.

1. Add a **Nios II Processor** to the system.
2. Add a **DDR2 SDRAM High-Performance Controller** and configure it to **full-rate** mode.
3. Add **Avalon-MM DDR Memory Half-Rate Bridge** to the system.
4. Configure the parameters of the Avalon-MM DDR Memory Half-Rate Bridge based on the memory controller. For example, for a 32 MByte DDR memory controller in full rate mode with 8 DQ pins (see [Figure 11-14](#)), the parameters should be set as the following:
  - **Data Width = 16**

For a memory controller that has 8 DQ pins, its local interface width is 16 bits. The local interface width and the data width must be the same, therefore data width is set to 16 bits.
  - **Address Width = 25**

For a memory capacity of 32 MBytes, the byte address is 25 bits. Because the master address of the bridge is byte aligned, the address width is set to 25 bits.
5. Connect `altmemddr_auxhalf` to the slave clock interface (`clk_s1`) of the Half-Rate Bridge.
6. Connect `altmemddr_sysclk` to the master clock interface (`clk_m1`) of the Half-Rate Bridge.
7. Remove all connections between Nios II processor and the memory controller, if there are any.
8. Connect the master interface (`m1`) of the Avalon-MM DDR Memory Half-Rate Bridge to the memory controller slave interface.
9. Connect the slave interface (`s1`) of the Avalon-MM DDR Memory Half-Rate Bridge to the Nios II processor `data_master` interface.
10. Connect `altmemddr_auxhalf` to Nios II processor clock interface.

## Device Support

Altera device support for the bridge components is listed in [Table 11-6](#).

**Table 11-6. Device Family Support**

Device Family	Avalon-MM Pipeline Bridge Support	Avalon-MM Clock-Crossing Bridge Support	Avalon-MM Half-Rate Bridge
Arria® GX	Full	Full	Full
Arria II GX	Full	Full	Full
Stratix®	Full	Full	Full
Stratix II	Full	Full	Full
Stratix II GX	Full	Full	Full
Stratix III	Full	Full	Full
Stratix IV	Full	Full	Full
Stratix V	Full	Full	Full
Stratix IV	Full	Full	Full
Cyclone II	Full	Full	Full
Cyclone III	Full	Full	Full
Cyclone IV	Full	Full	Full
Hardcopy®	Full	Full	Full
HardCopy II	Full	Full	Full
HardCopy III	Full	Full	Full
HardCopy IV	Full	Full	Full
MAX®	Full	No support	No support
MAX II	Full	No support	No support

## Hardware Simulation Considerations

The bridge components do not provide a simulation testbench for simulating a stand-alone instance of the component. However, you can use the standard SOPC Builder simulation flow to simulate the component design files inside an SOPC Builder system.

## Software Programming Model

The bridge components do not have any user-visible control or status registers. Therefore, software cannot control or configure any aspect of the bridges during run-time. The bridges cannot generate interrupts.



Avalon® Streaming (Avalon-ST) interconnect components facilitate the design of high-speed, low-latency datapaths for the system-on-a-programmable-chip (SOPC) environment. Interconnect components in SOPC Builder act as a part of the system interconnect fabric. They are not end points, but adapters that allow you to connect different, but compatible, streaming interfaces. You use Avalon-ST interconnect components to connect cores that send and receive high-bandwidth data, including multiplexed streams, packets, cells, time-division multiplexed (TDM) frames, and digital signal processor (DSP) data.

The interconnect components that you add to an SOPC Builder system insert logic between a source and sink interface, enabling that interface to operate correctly. This chapter describes four Avalon-ST interconnect components, also called adapters:

- **“Timing Adapter” on page 12–2**—adapts between sinks and sources that have different characteristics, such as ready latencies.
- **“Data Format Adapter” on page 12–5**—adapts source and sink interfaces that have different data widths.
- **“Channel Adapter” on page 12–7**—adapts source and sink interfaces that have different settings for the channel signal.
- **“Error Adapter” on page 12–9**—ensures that per-bit error information recorded at the source is correctly transferred to the sink

All of these interconnect components adapt initially incompatible Avalon-ST source and sink interfaces so that they function correctly, facilitating the development of high-speed, low-latency datapaths.

### Interconnect Component Usage

Interconnect components can adapt the data or control signals of the Avalon-ST interface. Typical adaptations to control signals include:

- Adding pipeline stages to adjust the timing of the ready signal
- Tying signals that are not used by either the source or sink to 0 or 1

Typical adaptations to data signals include:

- Changing the number of symbols (words) that are driven per cycle
- Changing the number of channels driven

When the interconnect component adapts the data interface, it has one Avalon-ST sink interface and one Avalon-ST source interface, as shown in [Figure 12-1](#). You configure the adapter components manually, using SOPC Builder. In contrast to the Avalon-MM interface, which allows you to create various topologies with a number of different master and slave components, you always use the Avalon-ST interconnect components to adapt point-to-point connections between streaming cores.

**Figure 12-1. Example of an Avalon-ST Interconnect Component in an SOPC Builder System**

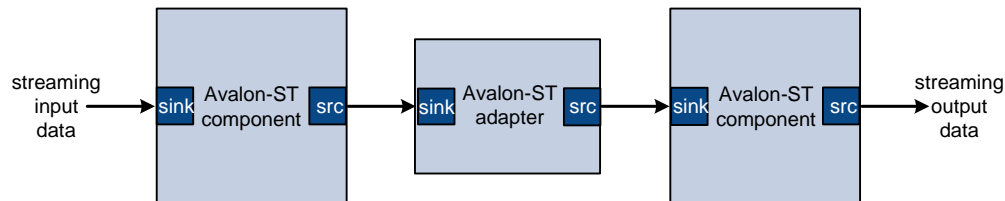

For details about the system interconnect fabric, refer to [Chapter 12, Avalon Streaming Interconnect Components](#). For details about the Avalon-ST interface protocol, refer to the [Avalon Interface Specifications](#).

[Figure 12-2](#) illustrates a datapath that connects a Triple Speed Ethernet MegaCore function to a Scatter-Gather DMA controller core using a timing adapter, data format adapter, and channel adapter so that the cores can interoperate.

## Address Mapping

**Figure 12-2. Avalon-ST Datapath Constructed Using Avalon Streaming Interconnect Components**

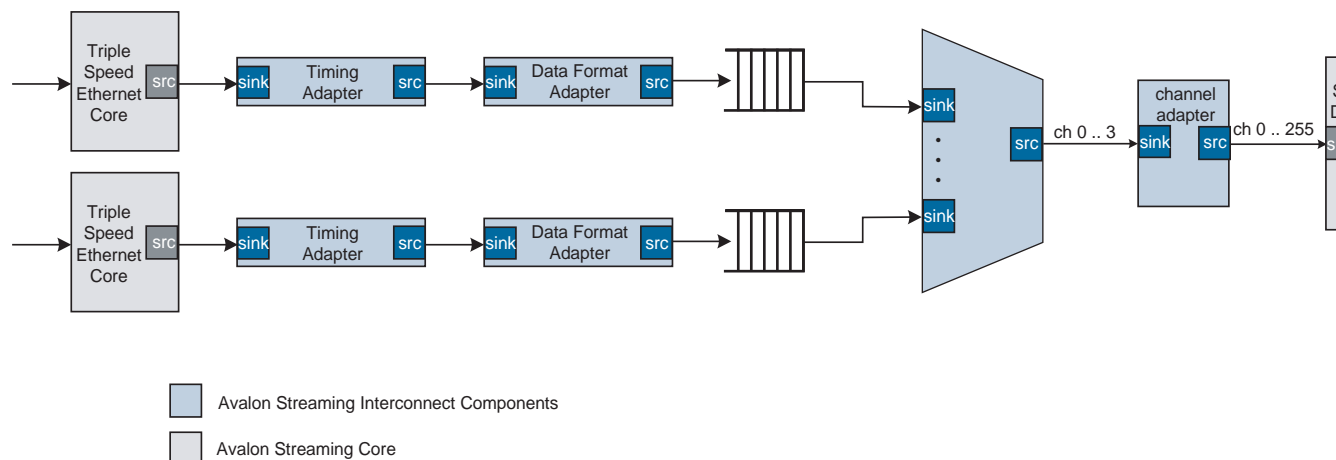

The control and status signals for the components containing source or sink interfaces can be mapped to a slave interface which is then accessible in the global Avalon address space.

## Timing Adapter

The timing adapter has two functions:



- It adapts source and sink interfaces that support the `ready` signal and those that do not.
- It adapts source and sink interfaces that support the `valid` signal and those that do not.
- It adapts source and sink interfaces that have different ready latencies.

The timing adapter treats all signals other than the `ready` and `valid` signals as payload, and simply drives them from the source to the sink. [Table 12-1](#) outlines the adaptations that the timing adapter provides.

**Table 12-1. Timing Adapter**

Condition	Adaptation
The source has <code>ready</code> , but the sink does not.	In this case, the source can respond to backpressure, but the sink never needs to apply it. The <code>ready</code> input to the source interface is connected directly to logical 1.
The source does not have <code>ready</code> , but the sink does.	The sink may apply backpressure, but the source is unable to respond to it. There is no logic that the adapter can insert that prevents data loss when the source asserts <code>valid</code> but the sink is not ready. The adapter provides simulation time error messages and an error indication if data is ever lost. The user is presented with a warning, and the connection is allowed.
The source and sink both support backpressure, but the sink's ready latency is greater than the source's.	The source responds to <code>ready</code> assertion or deassertion faster than the sink requires it. A number of pipeline stages equal to the difference in ready latency are inserted in the <code>ready</code> path from the sink back to the source, causing the source and the sink to see the same cycles as <code>ready</code> cycles.
The source and sink both support backpressure, but the sink's ready latency is less than the source's.	The source cannot respond to <code>ready</code> assertion or deassertion in time to satisfy the sink. A buffer whose depth is equal to the difference in ready latency is inserted to compensate for the source's inability to respond in time.

## Resource Usage and Performance

Resource utilization for the timing adapter depends upon the function that it performs. Table 12-2 provides estimated resource utilization for seven different configurations of the timing adapter

**Table 12-2. Timing Adapter Estimated Resource Usage and Performance**

Input Ready Latency	Output Ready Latency	Stratix® II and Stratix II GX (Approximate LEs)			Cyclone® II		Stratix (Approximate LEs)		
		f <sub>MAX</sub> (MHz)	ALM Count	Mem Bits	f <sub>MAX</sub> (MHz)	Logic Cells	f <sub>MAX</sub> (MHz)	Logic Cells	Mem Bits
1	2	500	2	0	420	2	422	1	0
1	3	500	2	0	420	3	422	2	0
1	4	500	4	0	420	4	422	3	0
1	0	500	21	80	420	183	422	20	80
2	1	456	21	80	401	188	317	21	80
3	1	456	21	80	401	188	317	21	80
4	1	456	21	80	401	188	317	21	80

## Instantiating the Timing Adapter in SOPC Builder

You can use the Avalon-ST configuration wizard in SOPC Builder to specify the hardware features. Table 12-3 describes the options available on the **Parameter Settings** page of the configuration wizard

**Table 12-3. Avalon-ST Timing Adapter Parameters**

Input Interface Parameters	
Parameter	Description
<b>Support Backpressure with the ready signal</b>	Turn on this option to add the backpressure functionality to the interface.
<b>Ready Latency</b>	When the <code>ready</code> signal is used, the value for <code>ready_latency</code> indicates the number of cycles between when the <code>ready</code> signal is asserted and when valid data is driven.
<b>Include valid signal</b>	Turn this option on if the interface includes the <code>valid</code> signal. Turning this option off means that data being received is always valid.
Output Interface Parameters	
<b>Support Backpressure with the ready signal</b>	Turn on this option to add the backpressure functionality to the interface.
<b>Ready Latency</b>	When the <code>ready</code> signal is used, the value for <code>ready_latency</code> indicates the number of cycles between when the <code>ready</code> signal is asserted and when valid data is driven.
<b>Include valid signal</b>	Turn this option on if the interface includes the <code>valid</code> signal. Turning this option off means that data driven is always valid.
Common to Input and Output Interfaces	
<b>Channel Signal Width (bits)</b>	Type the width of the <code>channel</code> signal. A channel width of 4 allows up to 16 channels. The maximum width of the <code>channel</code> signal is eight bits. Set to 0 if channels are not used.

**Table 12-3. Avalon-ST Timing Adapter Parameters**

Input Interface Parameters	
Parameter	Description
<b>Max Channel</b>	Type the maximum number of channels that the interface supports. Valid values are 0–255.
<b>Data Bits Per Symbol</b>	Type the number of bits per symbol.
<b>Data Symbols Per Beat</b>	Type the number of symbols per active transfer.
<b>Include Packet Support</b>	Turn this option on if the interfaces supports a packet protocol, including the <code>startofpacket</code> , <code>endofpacket</code> and <code>empty</code> signals.
Include Empty Signal	You can use this signal to specify the number of empty symbols in the cycle that includes the <code>endofpacket</code> signal. This signal is not necessary if the number of symbols per beat is 1.
<b>Error Signal Width (Bits)</b>	Type the width of the <code>error</code> signal. Valid values are 0–31 bits. Type 0 if the <code>error</code> signal is not used.
<b>Error Signal Description</b>	Type the description for each of the error bits. Separate the description fields by commas. For a connection to be made, the description of the error bits in the source and sink must match. Refer to “ <a href="#">Error Adapter</a> ” on <a href="#">page 12-9</a> for the adaptations that can be made when the bits do not match.

## Data Format Adapter

The data format adapter handles interfaces that have different definitions for the data signal. One of the more common adaptations that this component performs is data width adaptation, such as converting a data interface that drives two, 8-bit symbols per beat to an interface that drives four, 8-bit symbols per beat. The available data format adaptations are listed in [Table 12-4](#).

**Table 12-4. Data Format Adapter**

Condition	Description of Adapter Logic
The source and sink’s bits per symbol are different.	The connection cannot be made.
The source and sink have a different number of symbols per beat.	The adapter converts from the source’s width to the sink’s width. If the adaptation is from a wider to a narrower interface, a beat of data at the input corresponds to multiple beats of data at the output. If the input <code>error</code> signal is asserted for a single beat, it is asserted on output for multiple beats. If the adaptation is from a narrow to a wider interface, multiple input beats are required to fill a single output beat, and the output <code>error</code> is the logical OR of the input <code>error</code> signal.

## Resource Usage and Performance

Resource utilization for the data format adapter depends upon the function that it performs. Table 12-5 provides estimated resource utilization for numerous configurations of the data format adapter.

**Table 12-5. Data Format Adapter Estimated Resource Usage and Performance, 8 Bits per Symbol**

Input Symbols per Beat	Output Symbols per Beat	Number of Channels	Packet Support	Stratix II and Stratix II GX (Approximate LEs)			Cyclone II			Stratix (Approximate LEs)		
				f <sub>MAX</sub> (MHz)	ALM Count	Memory Bits	f <sub>MAX</sub> (MHz)	Logic Cells	Memory Bits	f <sub>MAX</sub> (MHz)	Logic Cells	Memory Bits
1	2	1	y	500	96	0	391	93	0	375	105	0
4	1	1	y	459	106	0	311	97	0	306	76	0
4	2	1	y	500	118	0	343	107	0	326	85	0
4	8	1	y	437	326	0	346	370	0	303	330	0
4	16	1	y	357	930	0	264	1005	0	231	806	0
1	2	188	y	321	110	15	187	137	15	209	153	15
4	1	105	y	244	125	2	148	183	2	150	137	2
4	2	105	y	277	101	2	172	134	2	173	108	2
4	8	130	y	322	255	41	175	279	41	187	262	41
4	16	30	y	268	341	106	166	563	106	153	471	106
4	1	105	n	269	107	2	177	185	2	167	99	2
4	2	54	n	290	109	1	193	203	1	176	91	1
4	3	10	n	249	149	18	189	251	16	159	217	18
4	5	222	n	281	300	40	199	381	40	182	316	40
4	6	30	n	312	184	40	201	385	40	198	241	40
4	7	139	n	253	285	56	159	416	56	161	427	56
4	8	198	n	311	281	40	190	247	40	198	257	40
4	15	160	n	259	370	121	165	733	121	149	697	121
4	16	36	n	227	255	105	391	93	0	146	491	105

## Instantiating the Data Format Adapter in SOPC Builder

You can use the Avalon-ST configuration wizard in SOPC Builder to specify the hardware features. Table 12-6 describes the options available on the **Parameter Settings** page of the configuration wizard.

**Table 12-6. Data Format Adapter Parameters**

Input Interface Parameters	
Parameter	Description
<b>Data Symbols Per Beat</b>	Type the number of symbols transferred per active cycle.
<b>Include the empty signal</b>	Turn this option on if the cycle that includes the <code>endofpacket</code> signal can include empty symbols. This signal is not necessary if the number of symbols per beat is 1.

**Table 12-6. Data Format Adapter Parameters**

<b>Input Interface Parameters</b>	
<b>Parameter</b>	<b>Description</b>
<b>Output Interface Parameters</b>	
<b>Data Symbols Per Beat</b>	Type the number of symbols transferred per active cycle.
<b>Include the empty signal</b>	Turn this option on if the cycle that includes the <code>endofpacket</code> signal can include empty symbols. This signal is not necessary if the number of symbols per beat is 1.
<b>Common to Input &amp; Output</b>	
<b>Channel Signal Width (bits)</b>	Type the width of the <code>channel</code> signal. A channel width of 4 allows up to 16 channels. The maximum width of the channel signal is 8 bits. Type 0 if you do not need to send channel numbers.
<b>Max Channel</b>	Type the maximum number of channels that the interface supports. Valid values are 0–255.
<b>Include Packet Support</b>	Turn this option on if the interface supports a packet protocol, including the <code>startofpacket</code> , <code>endofpacket</code> , and <code>empty</code> signals.
<b>Error Signal Width (Bits)</b>	Type the width of the <code>error</code> signal. Valid values are 0–31 bits. Type 0 if the <code>error</code> signal is not used.
<b>Error Signal Description</b>	Type the description for each of the error bits. Separate the description fields by semicolons. For a connection to be made, the description of the error bits in the source and sink must match. Refer to “ <a href="#">Error Adapter</a> ” on page 12-9 for the adaptations that can be made when the bits do not match.
<b>Data Bits Per Symbol</b>	Type the number of bits per symbol.

## Channel Adapter

The channel adapter provides adaptations between interfaces that have different support for the `channel` signal or for the maximum number of channels supported. The adaptations are described in [Table 12-7](#).

**Table 12-7. Channel Adapter**

<b>Condition</b>	<b>Description of Adapter Logic</b>
The source uses channels, but the sink does not.	You are given a warning at generation time. The adapter provides a simulation error and signals an error for data for any channel from the source other than 0.
The sink has channel, but the source does not.	You are given a warning, and the channel inputs to the sink are all tied to a logical 0.
The source and sink both support channels, and the source's maximum number of channels is less than the sink's.	The source's channel is connected to the sink's channel unchanged. If the sink's channel signal has more bits, the higher bits are tied to a logical 0.
The source and sink both support channels, but the source's maximum number of channels is greater than the sink's.	The source's channel is connected to the sink's channel unchanged. If the source's channel signal has more bits, the higher bits are left unconnected. You are given a warning that channel information may be lost.  An adapter provides a simulation error message and an error indication if the value of channel from the source is greater than the sink's maximum number of channels. In addition, the <code>valid</code> signal to the sink is deasserted so that the sink never sees data for channels that are out of range.

## Resource Usage and Performance

The channel adapter typically uses fewer than 30 LEs. Its frequency is limited by the maximum frequency of the device you choose.

## Instantiating the Channel Adapter in SOPC Builder

You can use the Avalon-ST configuration wizard in SOPC Builder to specify the hardware features. [Table 12-8](#) describes the options available on the **Parameter Settings** page of the configuration wizard.

**Table 12-8. Avalon-ST Channel Adapter Parameters**

Parameter	Description
<b>Input Interface Parameters</b>	
<b>Channel Signal Width (bits)</b>	Type the width of the <code>channel</code> signal. A channel width of 4 allows up to 16 channels. The maximum width of the <code>channel</code> signal is eight bits. Set to 0 if channels are not used.
<b>Max Channel</b>	Type the maximum number of channels that the interface supports. Valid values are 0–255.
<b>Output Interface Parameters</b>	
<b>Channel Signal Width (bits)</b>	Type the width of the <code>channel</code> signal. A channel width of 4 allows up to 16 channels. The maximum width of the <code>channel</code> signal is eight bits. Set to 0 if channels are not used.
<b>Max Channel</b>	Type the maximum number of channels that the interface supports. Valid values are 0–255.
<b>Common to Input and Output Interfaces</b>	
<b>Support Backpressure with the ready signal</b>	Turn on this option to add the backpressure functionality to the interface.
<b>Ready Latency</b>	When the <code>ready</code> signal is used, the value for <code>ready_latency</code> indicates the number of cycles between when the <code>ready</code> signal is asserted and when valid data is driven.
<b>Data Bits Per Symbol</b>	Type the number of bits per symbol.
<b>Data Symbols Per Beat</b>	Type the number of symbols per active transfer.
<b>Include Packet Support</b>	Turn this option on if the interfaces supports a packet protocol, including the <code>startofpacket</code> , <code>endofpacket</code> and <code>empty</code> signals.
Include Empty Signal	You can use this signal to specify the number of empty symbols in the cycle that includes the <code>endofpacket</code> signal. This signal is not necessary if the number of symbols per beat is 1.
<b>Error Signal Width (bits)</b>	Type the width of the <code>error</code> signal. Valid values are 0–31 bits. Type 0 if you do not need to send error values.
<b>Error Signal Description</b>	Type the description for each of the error bits. Separate the description fields by semicolons. For a connection to be made, the description of the error bits in the source and sink must match. Refer to <a href="#">“Error Adapter” on page 12-9</a> for the adaptations that can be made when the bits do not match.

## Error Adapter

The error adapter ensures that per-bit error information provided by source interfaces is correctly connected to the sink interface's input error signal. The adaptations are described in [Table 12-9](#):

### Instantiating the Error Adapter in SOPC Builder

You can use the Avalon-ST configuration wizard in SOPC Builder to specify the hardware features. [Table 12-9](#) describes the options available on the **Parameter Settings** page of the configuration wizard.

**Table 12-9. Avalon-ST Error Adapter Parameters**

Parameter	Description
<b>Input Interface Parameters</b>	
<b>Error Signal Width (bits)</b>	Type the width of the <code>error</code> signal. Valid values are 0–31 bits. Type 0 if the <code>error</code> signal is not used.
<b>Error Signal Description</b>	Type the description for each of the error bits. Separate the description fields by commas. For a connection to be made, the description of the error bits in the source and sink must match. Refer to “ <a href="#">Error Adapter</a> ” on <a href="#">page 12-9</a> for the adaptations that can be made when the bits do not match.
<b>Output Interface Parameters</b>	
<b>Error Signal Width (bits)</b>	Type the width of the <code>error</code> signal. Valid values are 0–31 bits. Type 0 if you do not need to send error values.
<b>Error Signal Description</b>	Type the description for each of the error bits. Separate the description fields by semicolons. For a connection to be made, the description of the error bits in the source and sink must match. Refer to “ <a href="#">Error Adapter</a> ” on <a href="#">page 12-9</a> for the adaptations that can be made when the bits do not match.
<b>Common to Input and Output Interfaces</b>	
<b>Support Backpressure with the ready signal</b>	Turn on this option to add the backpressure functionality to the interface.
<b>Ready Latency</b>	When the <code>ready</code> signal is used, the value for <code>ready_latency</code> indicates the number of cycles between when the ready signal is asserted and when valid data is driven.
<b>Channel Signal Width (bits)</b>	Type the width of the <code>channel</code> signal. A channel width of 4 allows up to 16 channels. The maximum width of the <code>channel</code> signal is eight bits. Set to 0 if channels are not used.
<b>Max Channel</b>	Type the maximum number of channels that the interface supports. Valid values are 0–255.
<b>Data Bits Per Symbol</b>	Type the number of bits per symbol.
<b>Data Symbols Per Beat</b>	Type the number of symbols per active transfer.
<b>Include Packet Support</b>	Turn this option on if the interfaces supports a packet protocol, including the <code>startofpacket</code> , <code>endofpacket</code> and <code>empty</code> signals.
<b>Include Empty Signal</b>	Turn this option on if the cycle that includes the <code>endofpacket</code> signal can include empty symbols. This signal is not necessary if the number of symbols per beat is 1.

## Installation and Licensing

The Avalon-ST interconnect components are included in the Altera MegaCore® IP Library, which is part of the Quartus II software installation. After you install the MegaCore IP Library, SOPC Builder recognizes these components and can instantiate them into a system.

You can use the Avalon-ST components without a license in any design that targets an Altera device.

## Hardware Simulation Considerations

The Avalon-ST interconnect components do not provide a simulation testbench for simulating a stand-alone instance of the component. However, you can use the standard SOPC Builder simulation flow to simulate the component design files inside an SOPC Builder system.

## Software Programming Model

The Avalon-ST interconnect components do not have any control or status registers that you can see. Therefore, software cannot control or configure any aspect of the interconnect components at run-time. These components cannot generate interrupts.



## Document Revision History

The following table shows the revision history for this document.

Date	Version	Changes
December 2010	1.0	First release in user guide document format. Refer to the <a href="#">Quartus II Development Software Literature Archive</a> website for previous revision history as <i>Quartus II Handbook, Volume 4: SOPC Builder</i> .

## How to Contact Altera

To locate the most up-to-date information about Altera products, refer to the following table.

Contact (1)	Contact Method	Address
Technical support	Website	<a href="http://www.altera.com/support">www.altera.com/support</a>
Technical training	Website	<a href="http://www.altera.com/training">www.altera.com/training</a>
	Email	<a href="mailto:custrain@altera.com">custrain@altera.com</a>
Product literature	Website	<a href="http://www.altera.com/literature">www.altera.com/literature</a>
Non-technical support (General) (Software Licensing)	Email	<a href="mailto:nacomp@altera.com">nacomp@altera.com</a>
	Email	<a href="mailto:authorization@altera.com">authorization@altera.com</a>









**Note to Table:**

(1) You can also contact your local Altera sales office or sales representative.

## Typographic Conventions

The following table shows the typographic conventions this document uses.

Visual Cue	Meaning
<b>Bold Type with Initial Capital Letters</b>	Indicate command names, dialog box titles, dialog box options, and other GUI labels. For example, <b>Save As</b> dialog box. For GUI elements, capitalization matches the GUI.
<b>bold type</b>	Indicates directory names, project names, disk drive names, file names, file name extensions, software utility names, and GUI labels. For example, <b>\qdesigns</b> directory, <b>D:</b> drive, and <b>chiptrip.gdf</b> file.
<i>Italic Type with Initial Capital Letters</i>	Indicate document titles. For example, <i>Stratix IV Design Guidelines</i> .
<i>italic type</i>	Indicates variables. For example, $n + 1$ . Variable names are enclosed in angle brackets (< >). For example, <file name> and <project name>.pof file.
Initial Capital Letters	Indicate keyboard keys and menu names. For example, the Delete key and the Options menu.

Visual Cue	Meaning
"Subheading Title"	Quotation marks indicate references to sections within a document and titles of Quartus II Help topics. For example, "Typographic Conventions."
Courier type	Indicates signal, port, register, bit, block, and primitive names. For example, <code>data1</code> , <code>tdi</code> , and <code>input</code> . The suffix <code>n</code> denotes an active-low signal. For example, <code>resetn</code> . Indicates command line commands and anything that must be typed exactly as it appears. For example, <code>c:\qdesigns\tutorial\chiptrip.gdf</code> . Also indicates sections of an actual file, such as a Report File, references to parts of files (for example, the AHDL keyword <code>SUBDESIGN</code> ), and logic function names (for example, <code>TRI</code> ).
	An angled arrow instructs you to press the Enter key.
1., 2., 3., and a., b., c., and so on	Numbered steps indicate a list of items when the sequence of the items is important, such as the steps listed in a procedure.
	Bullets indicate a list of items when the sequence of the items is not important.
	The hand points to information that requires special attention.
	A question mark directs you to a software help system with related information.
	The feet direct you to another document or website with related information.
	A caution calls attention to a condition or possible situation that can damage or destroy the product or your work.
	A warning calls attention to a condition or possible situation that can cause you injury.
	The envelope links to the <a href="#">Email Subscription Management Center</a> page of the Altera website, where you can sign up to receive update notifications for Altera documents.