

SPONSORED BY SPACECLAIM

DEVELOP^{3D}

SPECIAL REPORT

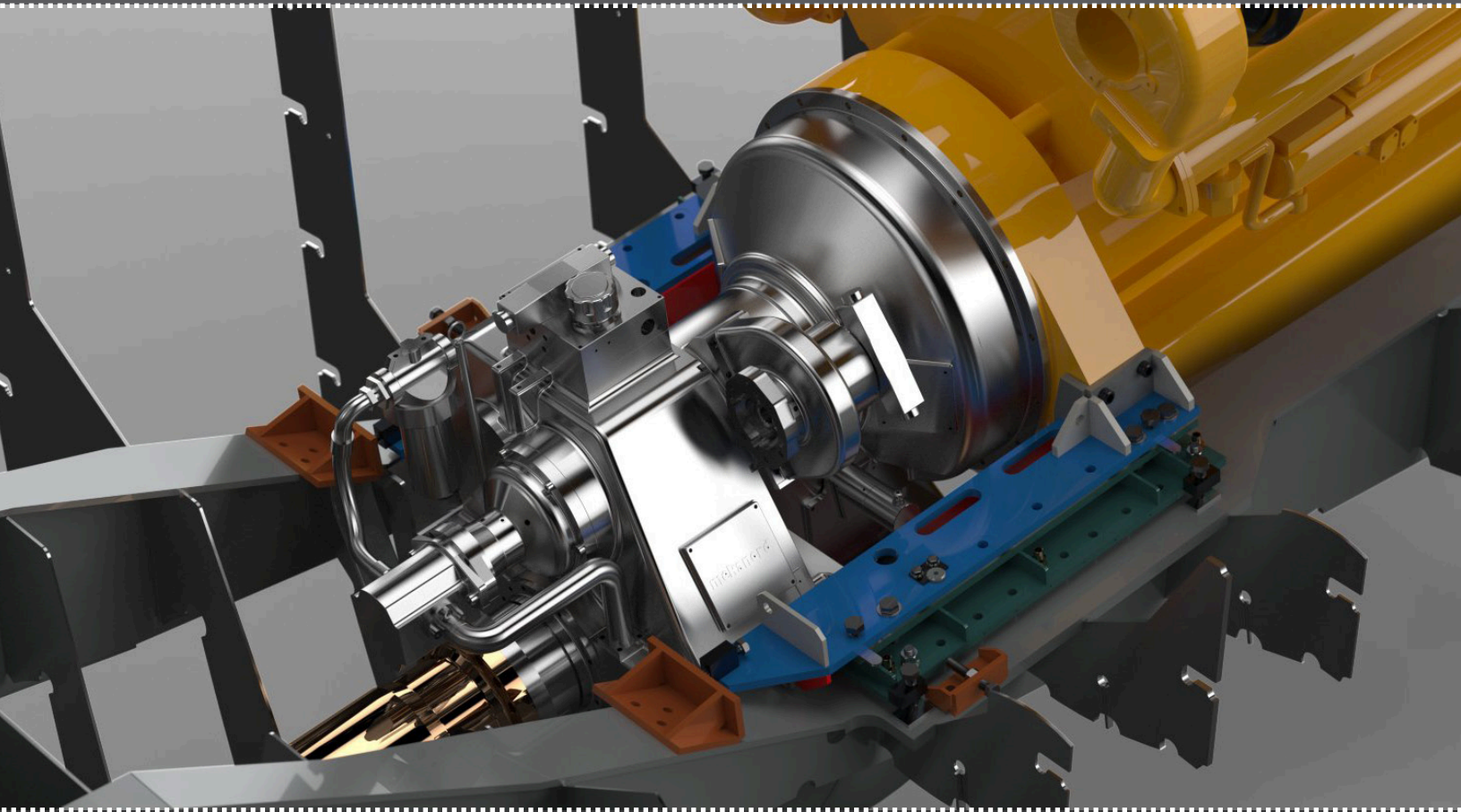

SPACECLAIM

IN MANUFACTURING

I

INTRO & CONTENTS

3D design tools have traditionally been used for very specific tasks within design and manufacturing. The complexity of expert systems has also meant expert users have been needed to operate them.

As a result, the use of 3D design technology in product development, outside of the design office, has not yet reached its true potential.

There are many areas where 3D geometry modeling can play an important and beneficial role. Request for Quotation (RFQ) and bid generation are two prime examples at the earliest stages of the design process.

Combining a potential customer's data and process requirements allows the cost potential and risks to be easily explored. Then once contracts are secured and work is underway, the same tools can enhance

all aspects of the project - from preparation for manufacturing, adding machining stock, removing features and even into viewing and adjusting tooling arrangements.

In this report we explore how three leading organizations have adopted 3D design workflows and how their businesses have been enhanced through the use of SpaceClaim.

We also explore how the tools within SpaceClaim, which are designed for use by non-experts, support these processes.

We'll then look at the common themes that arise from these conversations and find areas where the introduction of more flexible and easier to use digital design tools pay dividends to not only the user, but to the organization at large - and its customers.

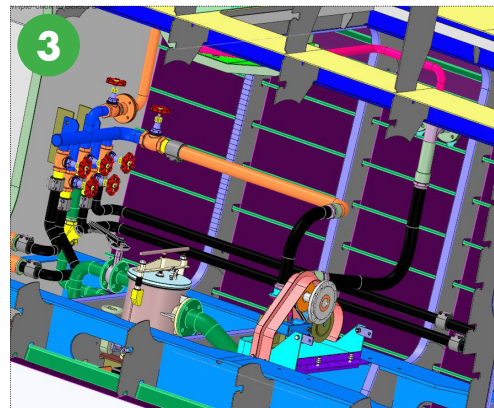

Australian Marine Technologies is a contractor in the naval architecture space, providing services across the globe

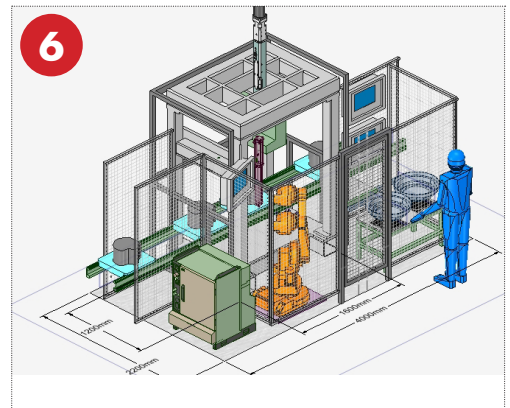

Expert Tooling & Automation uses SpaceClaim to define concepts and build customer confidence to win business

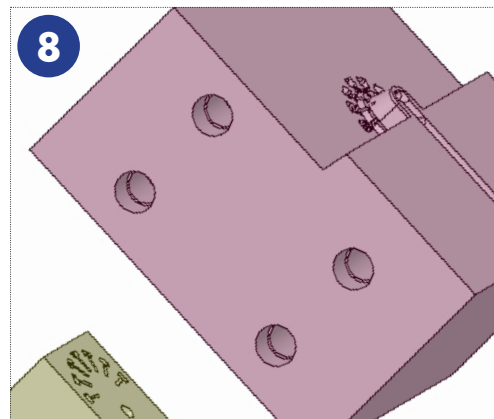

Team 1 Plastics leads in the plastics part production industry, specializing in molding services

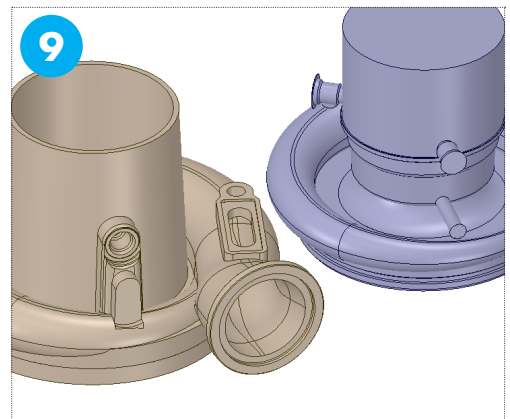

We explore some of the tools unique to SpaceClaim that can assist in the manufacturing industry



AUSTMARINETECH

Lightcraft Marine Engineering
System Design
Philippines

styler.austmarinetech@gmail.com

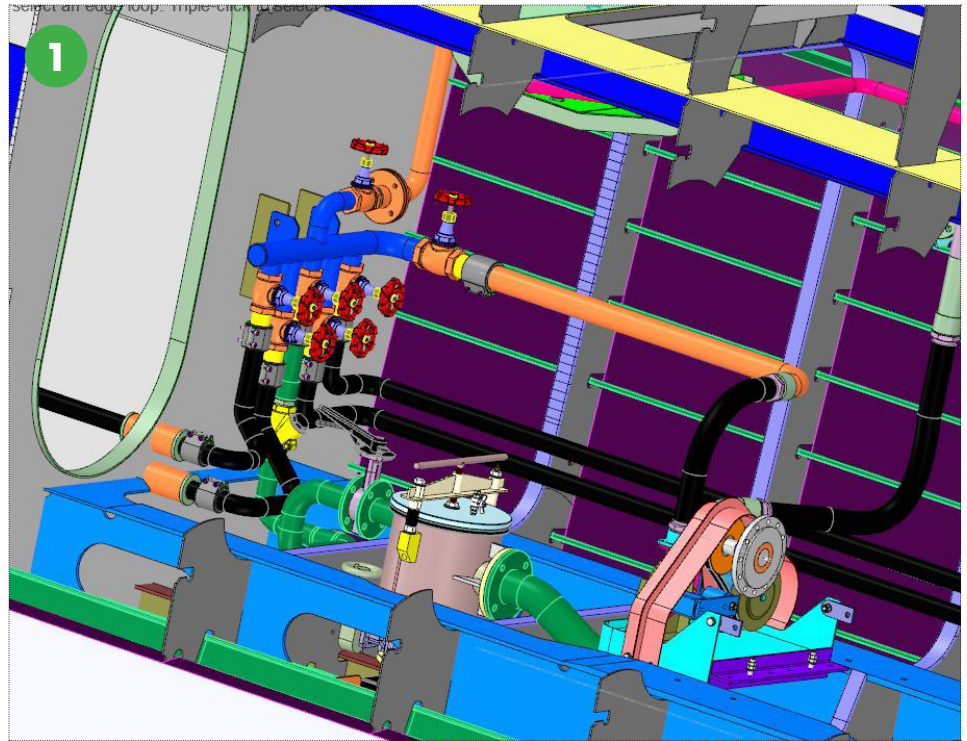

1 A 16 meter catamaran bilge manifold with SpaceClaim

Global Marine Design (GMD) of Western Australia (marinekits.com) has one of the largest portfolios of aluminum boat kits (Marinekits) spanning small pleasure craft, coastal patrol, offshore workboat, fast crewboat, fast ferry and windfarm service vessels from 5 to 35 meters.

Marinekits are delivered as a CNC cut and containerized 'flatpack' to shipyards or backyard workshops. They include all structural and mechanical drawings and data to facilitate a streamlined construction and commissioning process.

While GMD specializes in hull and superstructure, Austmarinetech is its principal contractor for the supply of mechanical systems design and drafting. Austmarinetech specifies and details a wide range of components, including engine mounting, shaftlines, steering, bilge drainage, fuel oil, raw water, exhaust, fresh, grey and black water circuits and airconditioning duct configurations.

"Virtually all of the large kits that GMD sells require some degree of propulsion and auxiliary system engineering design,"

explains Austmarinetech's owner, Steve Tyler. "This is a large comfort factor for customers that have opted to go away from a traditional shipyard purchase where you 'get what you're given', to a customized arrangement that better suits specific operational needs in way of function and quality of materials.

"Mechanical design can be as minimal as a main engine shafting and exhaust arrangement to a complete package covering all systems," he says.

With an expansive global customer base, each craft's system design can differ dramatically. As Tyler explains, "A lot of Asian clients want a complete engineering system package. Simply, they are more conversant with steel ship construction, a completely different animal with regard to engineering system design approach and materials, and wish to take advantage of a comprehensive technology transfer that will put them into the aluminum 'lightcraft' frame of mind."

THE 3D WORKFLOW

With GMD and Austmarinetech design co-ordination between hull and

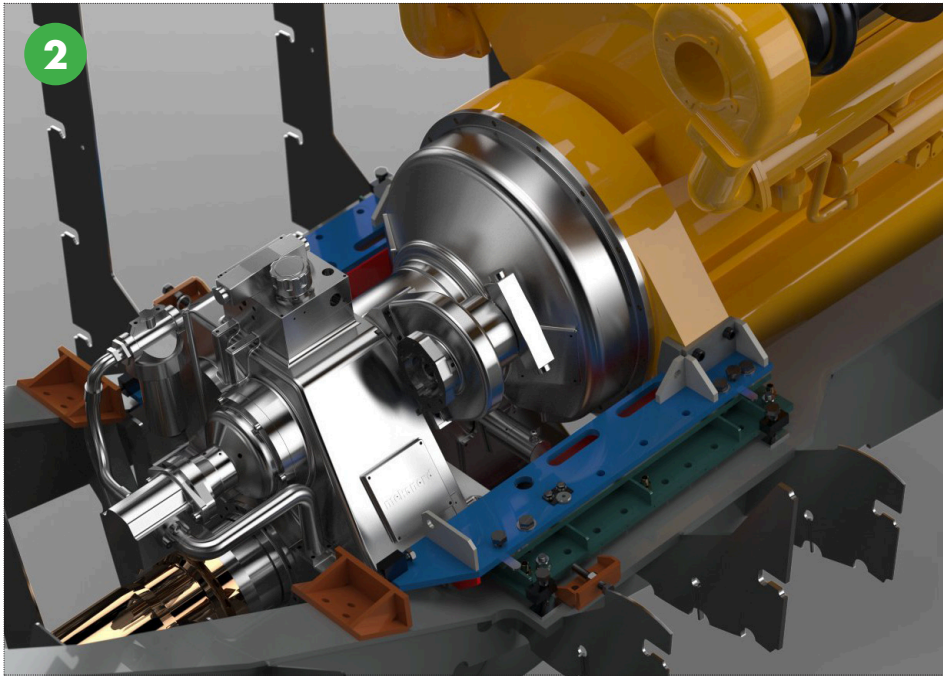

2 A Mekanord CPP gearbox mounted in a 20 meter windfarm vessel

superstructure and mechanical system has historically been a fragmented process. Originally, 3D was only used to generate the vessel structure. It was then converted to 2D transverse and longitudinal section views to facilitate the mechanical systems design.

Sections of the 2D mechanical design were then converted back to 3D to fully communicate the design intent. As Tyler states, “It was a protracted and painful process, not to mention extremely time consuming.”

Now, thanks to SpaceClaim, and the ever-increasing availability of OEM machinery models, the development process has become increasingly 3D oriented.

As Tyler explains “We simply take the entire 3D structural model straight from the naval architecture software, work with the architect to optimize engine girders and other key components, then fill the model with the required mechanical components – comfortable in the fact that we have 100% spatial appreciation of the areas where we need to fit equipment.

“The age-old bugbears of precise 2D design, structural brackets or a transition in hull shape where you least expect it are long gone.

“The ease of using SpaceClaim not only saves considerable time for us but also affords the luxury of virtually looking at the finished arrangement, making a critical assessment of this end product and, if a twinge of conscience dictates, going in and refining the product again.”

SpaceClaim has also had a positive impact on how Austmarinetech communicates designs. By supporting a process of ‘Show & Tell’, previously unattainable outside of huge marine design houses with unlimited resources, SpaceClaim has also aided expansion into new markets.

“Increasing business in the Far East brought with it language and translation issues so working in 3D has completely eliminated this troublesome aspect,” says Tyler. “We can provide customers, often thousands of miles away, with easy to comprehend 3D snapshots (JPEG), 3D PDF, STEP files and real to life 2D drawings of the combination of structure and engineering installations.

“It doesn’t matter what language the production crew speaks, as long as they can see a picture, they can build it.”

THE ROAD TO SPACECLAIM

While Tyler is now an experienced user



3 The top bearing assembly of a 20 meter windfarm vessel rudderstock

of SpaceClaim, his first experiences of 3D CAD left him less than enthused.

“I had undertaken extensive SolidWorks training and had unequivocally reached the conclusion that if 3D, in the context of my work type, was going to be this difficult, then I would stay with my trusty 2D and take the pain, grow old, less than gracefully,” he says. “The animosity and ill-humor of the parametric history tree was relentless; the tree was adamant that I be a bookkeeper.

“I was equally adamant that if I had wanted to be a bookkeeper, I would have studied bookkeeping or accountancy and not marine engineering. It was not a meeting of kindred spirits.”

Tyler was then introduced to SpaceClaim in 2007 when trial copies were made available on the Internet and soon found favor with its direct modeling methodology.

“When I initially started, I just did small areas in 3D,” he says. “Then over time I found that a 3D 35 meter vessel complete with all its engineering systems could live both quite comfortably and stably inside my PC. Now I use 3D for the entire creation process.”

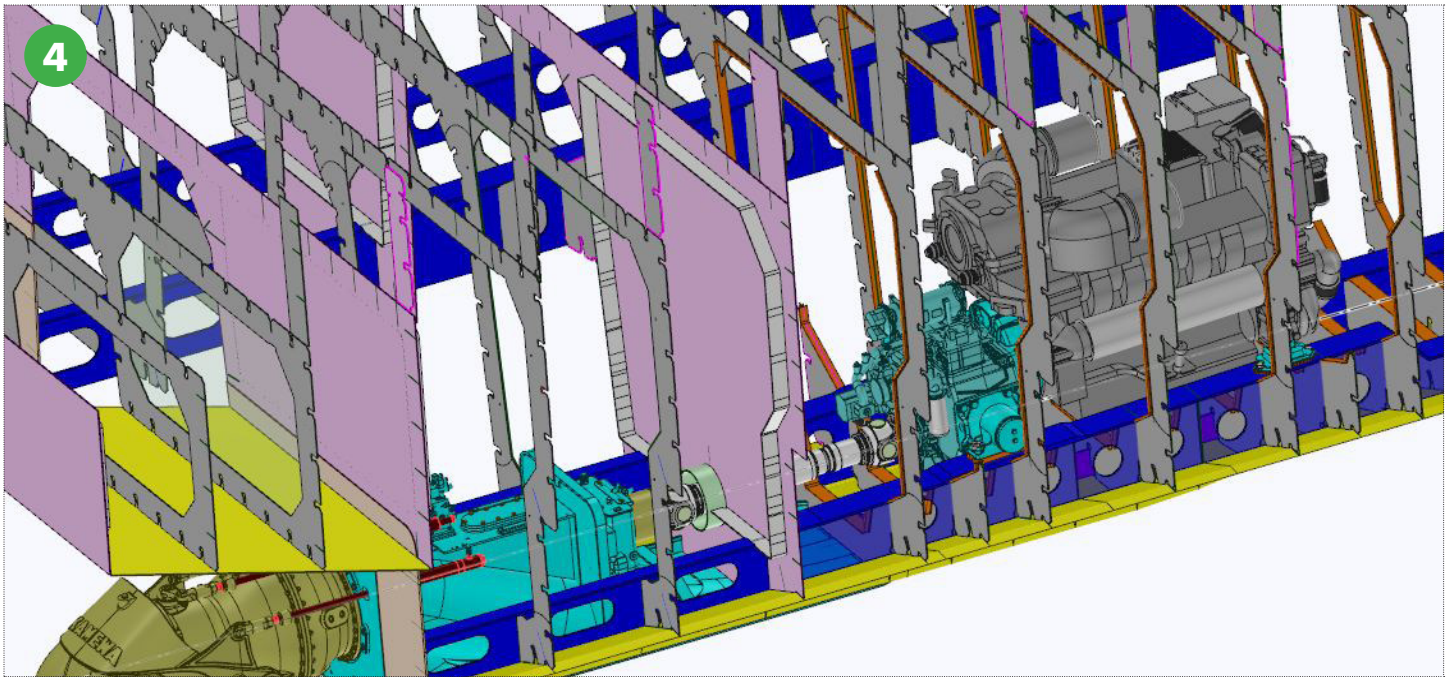

4 GMD 21 Mtr Fast Crew Boat, MTU 10V2000 Engine, ZF3000 Gearbox and KaMeWa 45A3 Waterjet

“We still have to effectively document the work but the great majority of illustrations are centred around a master JPEG (general arrangement) and supporting auxiliary views, also JPEG images. These are captured straight from SpaceClaim and some 2D sections and views necessary for dimensional context.”

“SpaceClaim is something I am working with all day, every day, and my process continues to evolve as both the software level of development and my ease of use and confidence grows,” he adds.

SUPPLIER RELATIONSHIPS

SpaceClaim has not only helped deliver workflow benefits inside Austmarinetech. The move to 3D has also made it much easier to work with machinery and component vendors. Tyler believes being able to obtain 3D geometry from suppliers is now key to efficient engineering across the entire marine design spectrum. “A number of suppliers for main propulsion engines, marine reduction gears and waterjets are forthcoming with comprehensive 3D models,” says Tyler. “3D is rapidly becoming the lingua franca of engineering design and we earnestly support organizations that have had the foresight to make their products available in 3D. The others, we genuinely believe,

don’t wish to support their products in a professional manner, so we don’t take them seriously when it comes to recommendation.”

CONCLUSION

SpaceClaim has proven to be an ideal marriage for Austmarinetech and since Tyler’s investment the software has become an indispensable facet of the company’s day-to-day operation.

“My assistant can frame out a 25m hull structure in four days and pass it across to me for engineering fit-out. I dump in engine, gear, shaftline and generator set,” explains Tyler. “From that moment onwards, I am inside a living hull. Everything I used to bump into, can be seen clearly and taken into account. The amount of rethinks on design approach has declined dramatically, the quality of my drawing and documentation output has increased exponentially and my personal satisfaction in the work has reached an all time high.”

Tyler admits to being a huge fan: “I am the world’s biggest cynic when it comes to some things, but I really cannot comprehend why a lot more people in my industry are not using SpaceClaim,” he concludes.

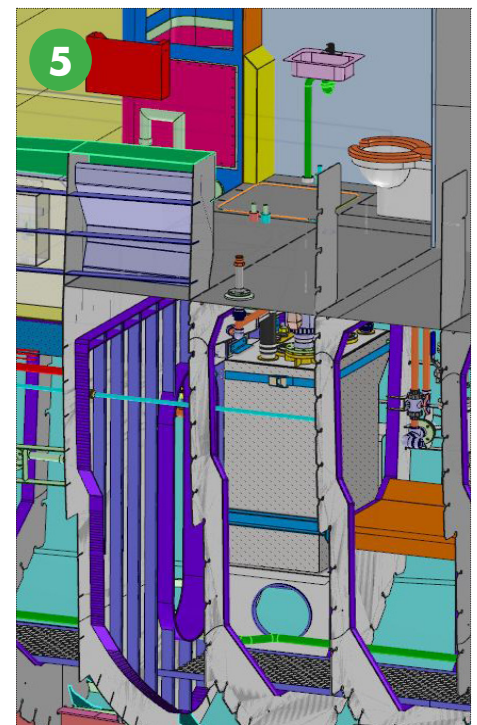

5 Black Water Installation for a Small Vessel

E

EXPERT TOOLING & AUTOMATION

Special Purpose Machinery
and Tooling Automation
Coventry, United Kingdom

experttooling.co.uk

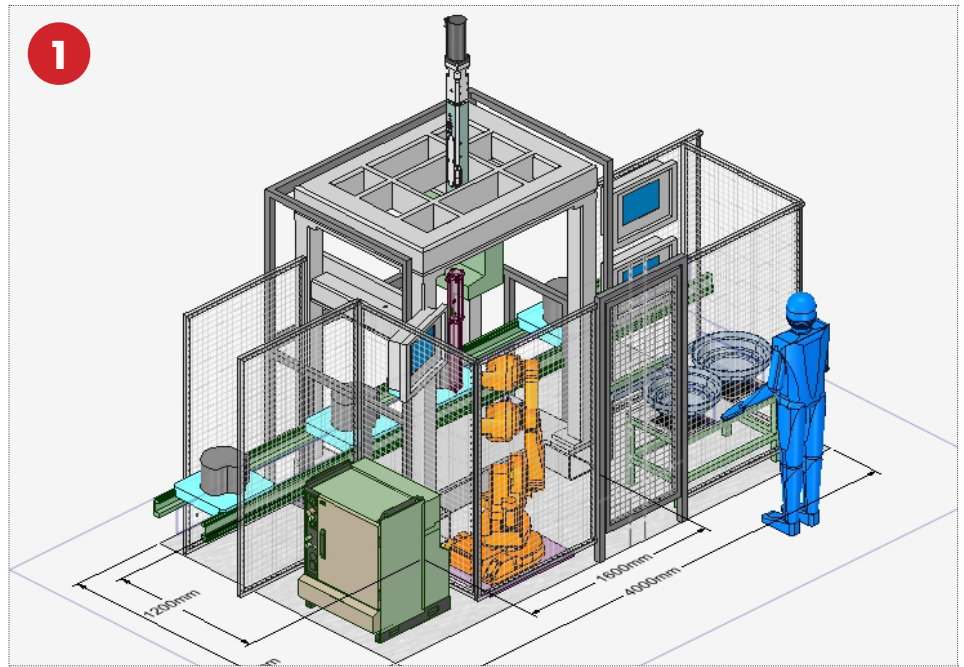

1 Robot loading bushes to an on line press station

Founded in 1972, Expert Tooling and Automation has become a recognized supplier of high quality industrial automation solutions in the UK and Europe.

While operating from multiple sites, the company's headquarters is a 30,000 square foot purpose built facility in Coventry, the heart of the British motor industry.

As sales engineer, Jason Glasse, describes "We are a manufacturer of custom designed production machinery and tooling. Our main areas of business are the automotive, medical and other sectors that require bespoke equipment.

Into the automotive industry we supply everything from the design and manufacture of Body In White tooling for Virtual Prototype build to robotic assembly line. The medical sector tends to be palletized or rotary based assembly and test machines where parts are automatically fed, assembled, tested and packaged.

"A company will come to us with a product and we will formulate a process and machine concept to automatically assemble it. We will take the product into SpaceClaim and design the concept around it."

REINVENTING THE QUOTATION

Traditionally quotations consist of text describing the proposed concept and a 2D layout drawing. However through the use of SpaceClaim, Expert Tooling and Automation is able to present a 3D concept that is easier to follow and, according to Glasse "enables us to get across the concept a lot easier than reading the text along with the layout drawing."

Presenting a 3D model of a concept also allows a customer to visualize the solution and 'buy into' the concept.

SPEED VS ACCURACY

Expert Tooling and Automation currently uses a mix of CATIA and SolidWorks for its detailed engineering work, but it felt that something more efficient was needed to help develop accurate quotations and concepts for customers in a suitable timeframe.

As Thompson explains, "We use CATIA in-house because it's driven by our major automotive customers. It's fine as an engineering design tool, but it's so laborious to create thoughts and ideas in non-complex models quickly. We were looking for some quick but high powered kit and SpaceClaim dropped into that space."

REUSING DATA

One of the key benefits of using SpaceClaim has been the speed with which concepts can be pulled together. Expert Tooling and Automation's team has a library of pre-built models or supplier models (such as robots) which can be brought into SpaceClaim along with customer data. An accurate model can then be built up very rapidly to show the form and function of the machine.

As Thompson says, "We still have a lot of design work to do, but by getting the bare bones of the model together, you can see the sizing of the equipment / robots. It's very easy to swap things in and out. The models look more realistic and help to sell the concept when a customer can see their components and commercially available parts like pneumatic cylinders, robots, etc. It builds customers' confidence in the solution and Expert's ability to manufacture the system."

This confidence in Expert Tooling and Automation's knowledge and capability is something that the team feels is key to winning bids for projects, and has to be built in right from the quotation stage.

SpaceClaim allows the user to quickly grasp the basics of 3D modeling with the most basic training. Someone with minimal CAD experience can quickly become a proficient user in a matter of weeks.

PRESENTING TO THE CUSTOMER

Quotation documents are put together with assets from SpaceClaim to show a concept and to help explain the team's thinking. When it comes to presenting live to the customer, additional benefits can be drawn from having 3D data at hand. For instance, 3D PDFs, which show interactive views of the model, can be used to center discussions on. Expert Tooling and Automation has also recently invested in KeyShot, a photorealistic rendering add-on for SpaceClaim. While rendering is not traditionally associated with the machinery industry, it's clear that Expert Tooling and Automation is gaining benefits.

As Glasse explains, "Although in a rendering a machine still looks the same and does the same job as it does in a

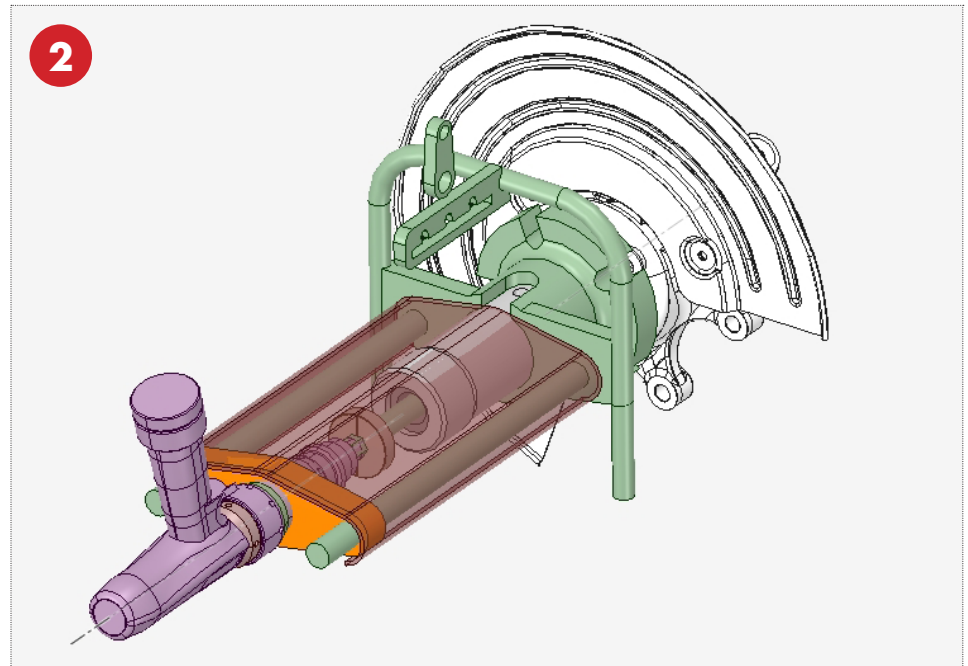

2 Automotive drive shaft hydraulic / driver assembly tool

drawing, it presents a 'real life like' virtual image and again gives the customer confidence. We also find that our images are sometimes used by our customers in their internal presentations."

CONCEPT TO ENGINEERING

Once the idea is delivered and the bid won, Expert Tooling and Automation then moves to the detailed engineering stage. At present, this involves internal meetings where the projects are handed over to the next team. Again, the use of 3D at the earliest stages pays dividends as the team has a much clearer picture of the concept and the customer's requirements.

As Thompson says, "We don't use the SpaceClaim models directly for manufacturing, our project proposals are forwarded to the engineering department. They have multiple seats of CATIA which are used to take things further. Sometimes they might use these models as a reference or for comparison as things progress."

That said, one of our sister companies is also using SpaceClaim in the same way as we do, for concept work, but they've stepped it up and are starting to use it for detail engineering work as well."

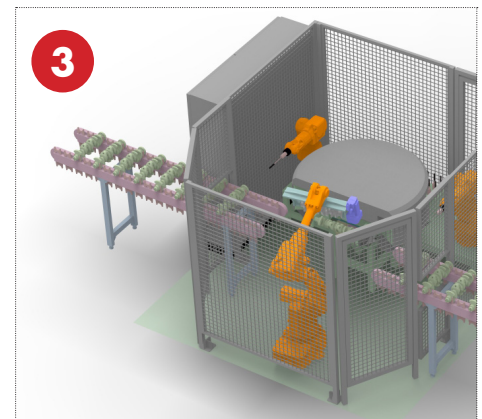

3 Automotive crank deburring cell

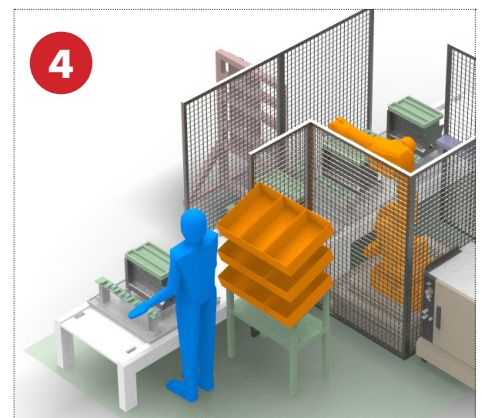

4 Robotic adhesive application to automotive engine



TEAM 1 PLASTICS

Plastics Industry
Michigan, USA

team1plastics.com

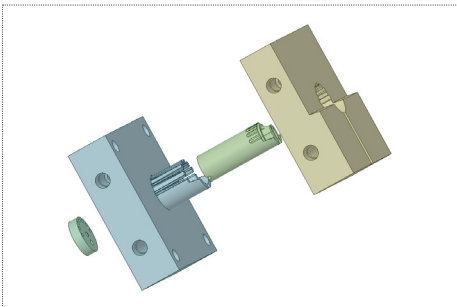

- 1 The original mold design for the core block that was more complex and prone to breakage**

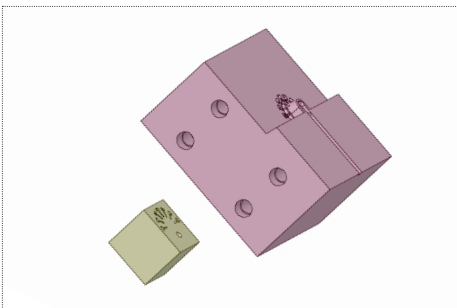

- 2 The core block was redesigned with more simple, robust design to reduce or eliminate the failures**

Founded in the mid 1980s by three young plastics engineers, who saw the need for midwest-based suppliers of high quality plastics parts to the automotive industry, Team 1 Plastics has become a powerhouse in the region. In just 13 short years, the company was voted the 101st fastest growing private company in the United States by Inc Magazine.

Providing molding services in today's highly competitive and globalized economy means the team has specialized its skill set, combining rapid response to customer demands with use of both local suppliers and outsourced work to the Far East. But over a 25 years later, Dave Seedorf, engineering manager, says the company is still true to its goal of providing "good parts, on time."

According to Seedorf, "We don't actually do the tool building. We have long standing relationships with our customers and suppliers and utilize mold building sources in the local South West Michigan area along with international partners in Seoul, Korea and Oyonnox, France. All of our mold builders are responsible for the mold designs. Team 1 reviews and approves the mold designs and some of our customers request that they review/ approve the mold designs as well."

Seedorf feels that alongside this effective business model, Team 1's other key differentiator is its location. "We are very close to our customers in the South West Michigan area. We're able to turn around parts and react very promptly. This comes from having people on board that are very savvy, can understand and communicate technical issues to customers and give them the service they deserve. The focus is to make sure the customers get the attention they need, when they need it."

ENABLING RAPID REACTION

To ensure that the engineering team is able to quickly and efficiently respond to customer requests, each of the three team members have access to SpaceClaim to enable clear and concise communication with customers. As Seedorf explains, "We've used other 3D software but there was nothing with the flexibility to turn things around so promptly. We're not design responsible for part, our customers are. But if, for some reason, issues are

found with the manufacturability of a part, we can easily modify a part model." This works to all parties' advantage. Rather than relying on sketches or a long drawn out phone conversation, the engineering team is able to load up the data, make the appropriate design change, document it and send it back to the customer for discussion and approval. This allows them to see exactly what the suggested changes and modifications are, without ambiguity.

INTEGRATING DESIGN CHANGE

With the potential for IP loss from the exchange of 3D data a hot topic for the industry, the fact that 3D geometry is passing between Team 1 Plastics and its customers does seem to buck a growing trend and to great advantage for the company. According to Seedorf, the long standing partnerships between Team 1 Plastics and its customer base means that trust has been established and assists in making the design iteration process more fluid. "The majority of the time, the customers accept the data and changes we propose and we proceed with our geometry from SpaceClaim. If that's not acceptable, they typically propose something different in their own 3D CAD system and resubmit that, on which we work."

"Some of our customers do require they modify their own model internally, but they request the data from us and incorporate that. It goes both ways depending on the situation."

INSPECTING AND APPROVING TOOLING

Team 1 Plastics also brings SpaceClaim into its tooling sign off process. As Seedorf explains, "We use it not only for communication with customers, but also for part design and approving tool designs from our partners in IGES or STEP format. We then make adjustments where needed – then resubmit it into the suppliers with the appropriate changes."

CONCLUSION

With the help of SpaceClaim and the benefits it brings to the business in terms of increased flexibility, quicker turnaround times, streamlining processes and concise communication with customers, will no doubt ensure that Team 1 Plastics is soon able to gain a spot in the top 100 fastest growing private companies.

2D DATA REUSE

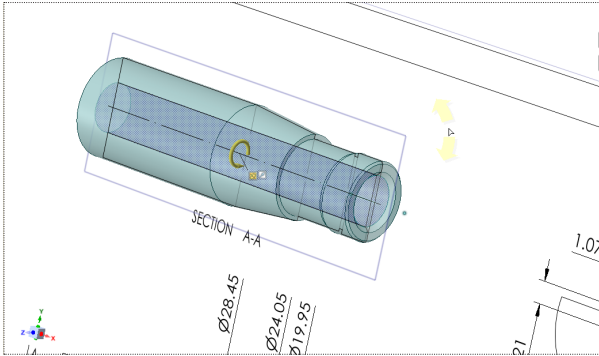

2D drawing data can be imported using a variety of widely used formats. SpaceClaim's modeling tools can then be used to quickly and efficiently construct 3D geometry for use in CAM applications

FEATURE REMOVAL

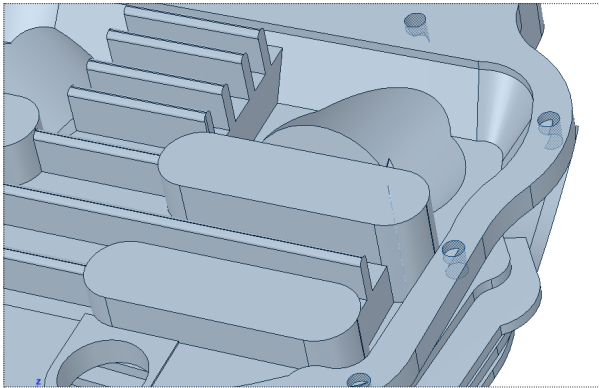

Importing 3D geometry for machining will require repurposing for the manufacturing process. Much of this relates to feature editing or removal, such as holes for casting purposes

DOCUMENTING DRILLING

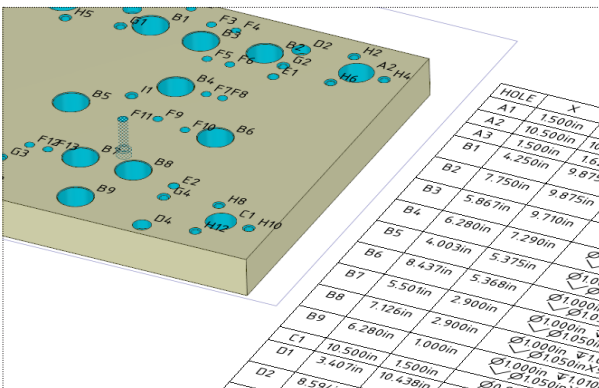

Drilling centric data can be imported, features found and hole tables generated which maintain associative links to the features. Any updates to the machining plan can quickly be propagated and documented

DATA REPAIR

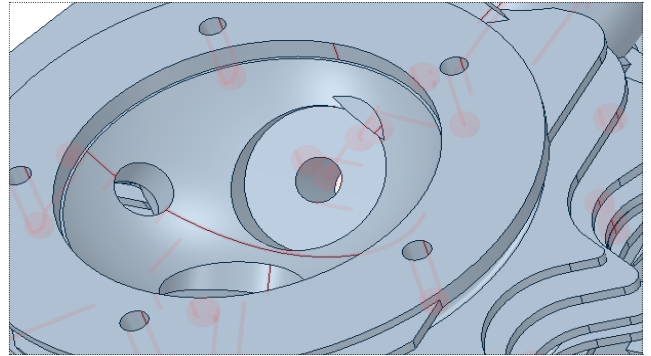

Imported 3D geometry can be imported from a wide variety of formats and systems. SpaceClaim includes a wealth of tools to repair, improve and work with that data to create manufacture suitable data

FEATURE ADAPTATION

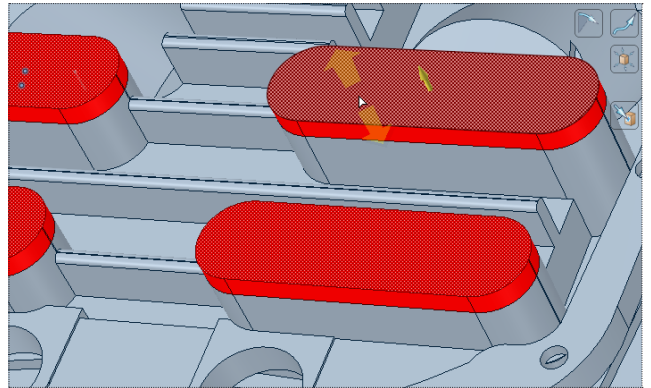

Another key part of the machining preparation process is the ability to take customer data and quickly adapt geometry. Whether for adding machining stock, adapting features or adding geometry

DESIGN FOR CASTING

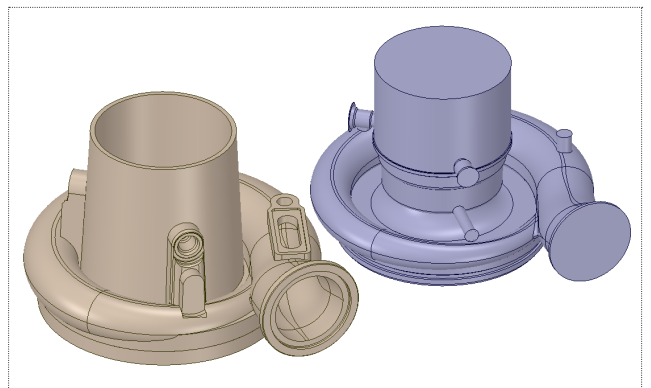

The Extract Volume operation, while developed to assist with creating internal fluid volumes for use in Computational Fluid Dynamics (CFD), can also be used to quickly and effortlessly generate cores for casting design



SUMMARY

Today's manufacturing engineer often has many roles, whether preparing products for production, providing sales support or developing concepts for quotation and bids. With such a diverse set of tasks it is often hard to attain highly specialized knowledge in 3D CAD.

SpaceClaim's direct modeling tool is widely acknowledged for its ease of use in geometry creation and editing. This means it is well suited to non-expert users and can be adopted in both niche and mainstream areas of manufacturing.

In the three case studies featured in this report this is illustrated with four common themes.

#1 SPEED & ACCURACY

Today's engineers are under more time pressure than ever before. The requirement to deliver each stage of a project on time and with accuracy is fundamental, whether carrying out full detailing work or preparing concepts to demonstrate tooling or an automation line to customers.

SpaceClaim is designed to offer a shorter learning curve. In fact, some users do not feel the need to take any formal training. This means engineers can get up to speed rapidly, start to work on live projects and experience the benefits more quickly.

It gives organizations the ability to rapidly react to customer requirements, deliver RFQ documents and build customer confidence with higher quality assets used for presentations.

#2 DATA REUSE

Very few organizations work in isolation and all three featured companies receive customer data in one form or another. The ability to work effectively with this data is absolutely key. SpaceClaim offers a wide range of data import options.

It also provides a dedicated set of tools for working with so-called "dumb" geometry. Perhaps more importantly, with its direct modeling approach, as opposed to one based on history, adaptations, edits and changes can be made in a much shorter time frame.

#3 INFLUENCING PURCHASING

Data generated internally or by suppliers is having a major influence on the engineering work. The ability to pull in geometry from suppliers is directly impacting specification and purchasing decisions. If data is readily available, a particular supplier's product is more likely to be specified in the final build.

Conversely, assets that are generated internally are being reused for presentations to management. Derived from the 3D models, the schematics and photorealistic renderings deliver greater impact and clarity which helps win projects.

#4 ENABLING COMMUNICATION

A common theme across all featured companies is how the widespread use of SpaceClaim helps improve the clarity of communication.

Communication with customers helps win more contracts. Some firms cited that greater clarity in their bids, presentations and documentation gives customers greater confidence in their work.

Also the use of 3D data to present ideas and concepts brings huge benefits to the sales process.

KEY TAKEAWAY

SpaceClaim's ease of use makes it suitable for the majority of manufacturing engineers, rather than just a specialist few.

It is also powerful enough to capture concepts and ideas quickly, providing huge benefits for all three organizations in this report.

This is not only in terms of user productivity, but in paying real dividends when it comes to business acquisition and maintaining customer confidence.

This report was created by X3DMedia and is sponsored by SpaceClaim

X3DMEDIA
community through content

