

# Special Tunnel Blasting Techniques for Railway Projects

More Ramulu

*Central Institute of Mining & Fuel Research, Nagpur,  
India*

## 1. Introduction

Excavations of tunnels are common features in mining and civil engineering projects. In absence of initial free face, solid blasting method is employed for excavation of tunnels, drifts and mine roadways, which have many similarities in configurations and in different cycles of operation followed during excavation. A greater proportion of world's annual tunnel advance is still achieved by drilling and blasting. In spite of inherent disadvantages of damaging the rock mass, drilling and blasting has an unmatched degree of flexibility and can overcome the limitations of machine excavations by Tunnel Boring Machine (TBM) or road headers. In spite of no major technical breakthrough, the advantages like low investment, availability of cheap chemical energy in the form of explosives, easy acceptability to the practicing engineers, the least depreciation and wide versatility have collectively made the drilling and blasting technique prevail so far over the mechanical excavation methods.

Since tunnels of different sizes and shapes are excavated in various rock mass conditions, appropriate blast design including drilling pattern, quantity and type of explosive, initiation sequence is essential to achieve a good advance rate causing minimal damage to the surrounding rock mass. The cost and time benefit of the excavation are mostly decided by the rate of advance and undesired damage.

Excavation of tunnels, except in geologically disturbed rock mass conditions, is preferred with full face blasting. It is common to excavate large tunnels of 80-90 m<sup>2</sup> cross-section in sound rock masses by full face in a single round. However, tunnels larger than 50m<sup>2</sup> cross-sectional area driven through incompetent ground condition are generally excavated in smaller parts.

Introduction of electro-hydraulic jumbo drills with multiple booms, non-electric initiation system, small diameter explosives for contour blasting and fracture control blasting are some of the recent developments in tunnel blasting. Prediction and monitoring the blast damage, application of computers in drilling, numerical modelling for advanced blast design, use of rock engineering systems for optimization and scheduling of activities have been the areas of intense research in today's competitive and high-tech tunnelling world

In tunnel blasting, explosives are required to perform in a difficult condition, as single free face (in the form of tunnel face) is available in contrast to bench blasting where at least two free faces exist. Hence, more drilling and explosives are required per unit volume of rock to be fragmented in the case of tunnel blasting. A second free face, called 'cut', is created initially during the blasting process and the efficiency of tunnel blast performance largely depends on the proper development of the cut. The factors influencing the development of the cut and the overall blast results are dependent on a host of factors involving rock mass type, blast pattern and the tunnel configurations.

## 2. Blasting mechanics

The tunnel blasting mechanics can be conceptualised in two stages. Initially, a few holes called cut holes are blasted to develop a free face or void or cut along the tunnel axis. This represents a solid blasting condition where no initial free face is available. Once the cut is created, the remaining holes are blasted towards the cut. This stage of blasting is similar to bench blasting but with larger confinement. The results of tunnel blasting depend primarily on the efficiency of the cut hole blasting. The first charge fired in cut resembles crater blasting. Livingston's spherical charge crater theory (Livingston, 1956) suggests that the blast induced fracturing is dominated by explosion gas pressure which is supported by Liu and Katsabanis (1998). Duvall and Atchison (1957), Wilson (1987) and others believe that the stress wave induced radial fracturing is the dominating cause of blast fragmentation and gas pressure is responsible only for extension of the fractures developed by the stress wave.

The natures of influence of the two pressures i.e. of stress and gas are different in the jointed rock mass where the stress waves is useful in fragmentation as the joints restrict the stress wave propagation. The gases, on the other hand, penetrate the joint planes and try to separate the rock blocks. The fragments' size and shape in jointed formations are dominated by the gas pressure and the joint characteristics. The roles of the stress wave and the gas pressures are no different in the second stage of tunnel blasting. But with the availability of free face, the utilisation of stress wave is increased. The rock breakages by rupturing and by reflected tensile stress are more active in the second stage because of cut formation in the first stage.

## 3. Parameters influencing tunnel blast results

The parameters influencing the tunnel blast results may be classified in three groups:

- i. Non controllable
  - ii. Semi-controllable
  - iii. Controllable
- Rock mass properties,  
(a) Tunnel geometry & (b) Operating factors, and  
Blast design parameters including the explosive properties.

## 4. Models for prediction of tunnel blast results

Specific Charge is one of the important parameter of prediction of tunnel blast results. Pokrovsky (1980) suggested the following empirical relation to determine the specific charge ( $q$ ) in tunnels (Eq. 1):

$$q = q_1 \cdot s_t \cdot f \cdot s_{wr} \cdot d_{ef}, \text{ kg/m}^3 \quad (1)$$

where,

$q_1$  = specific charge for breaking of rock against a free face in  $\text{kg/m}^3$ ,

$s_t$  = factor for structure and texture of rock,

$$f = \text{rock confinement} = 6.5 / \sqrt{A}, \quad (1a)$$

$A$  = area of tunnel ( $\text{m}^2$ ),

$s_{wr}$  = relative weight strength of explosive (ANFO = 1), and

$d_{ef}$  = factor for diameter of explosive cartridge,

According to Langefors and Kihlstrom (1973), the specific charge ( $q$ ) is related to the cross-sectional area of the tunnel ( $A$ ,  $\text{m}^2$ ) as given below:

$$q = (14/A) + 0.8 \text{ kg/m}^3 \quad (2)$$

The specific charge in the cut holes remain maximum and it can be upto  $7 \text{ kg/m}^3$  in a parallel cut.

## 5. Rock mass damage

The aspects of blast induced rock mass damage around a tunnel opening and its assessment have been the subjects of in-depth research for quite a long time. The type of damage can be grouped into three categories: (i) fabric damage due to fracturing, (ii) structural damage exploiting discontinuities and shears, and (iii) lithological damage causing parting between two different rock units or lithological boundaries between similar rock types.

Chakraborty et al. (1996a) observed in the tunnels of Koyna Hydro-electric Project, Stage-IV poor pull and small overbreak in volcanic breccia having low  $Q$  value, P-wave velocity and modulus of elasticity. On the other hand, large overbreak on the sides due to vertical and sub-vertical joints and satisfactory pull were found in the compact basalts having comparatively much higher  $Q$  value, P-wave velocity and modulus of elasticity. The fact is attributed to the presence of well defined joints in compact basalts which is absent in volcanic breccia.

The effects of joint orientations on overbreak/underbreak and pull in heading and benching operations during tunnel excavations are explained by Johansen (1998). The work of Johansen (1998) describes that joints normal to tunnel direction are favorable for good pull and parallel to the tunnel advance direction yield poor pull. advance direction. The obtuse angle between joints and tunnel direction results in more damage and breakage towards the wall of that angle.

The dip direction of the blasted strata on pull could be well experienced while blasting in the development faces of Saoner coal mine where the pull was increased by 11 per cent in the rise galleries compared to that in the dip galleries (Chakraborty, 2002). Longer rounds in tunnels can be pulled when the dominant joint sets are normal to the tunnel axis. Whereas, better pull can be obtained in shaft sinking if the discontinuities are parallel to the line joining the apex of the Vs in a V-Cut Hagan (1984).

Chakraborty (2002) observed the following influences of joint directions on pull and overbreak (Table 1).

Joint Orientation		Face Advance	Roof Overbreak
Dip	Strike with respect to tunnel axis		
Steep	Parallel	Very poor	Very small
Steep	Across	Very good	Very large
Gentle	Across	Fair	Large
Moderate	Across/oblique	Good	Small

Table 1. Influence of joint direction on overbreak (Chakraborty, 2002)

The gentle, moderate and steeply dipping joint planes signify the dip angles as 0°-30°, 30°-60° and 60°-90° respectively. Similarly, strikes with respect to tunnel axis are mentioned as parallel, oblique and across to indicate that the joint strike intersection angle with the tunnel axis as 0°-30°, 30°-60° and 60°-90° respectively.

If the geo-mechanical properties of the constituting formations of a tunnel are quite different, the stress energy utilisation and resulting fragmentation are adversely affected. Chakraborty et al. (1996b) suggested an increase of specific charge by a per cent equal to ten times the number of contact surfaces.

Engineers International Inc. modified Basic RMR (MBR) considering blast-induced-damage adjustments, as shown in Table 2, were suggested for planning of caving mine drift supports (Bieniawski,1984). Chapter 4 in the present publication defines basic RMR.

Method of Excavation	Damage Level	Blast Damage Adjustment Factor	Per cent Reduction
1. Machine boring	No damage	1.0	0
2. Controlled blasting	Slight	0.94-0.97	3-6
3. Good conventional blasting	Moderate	0.9-0.94	6-10
4. Poor conventional blasting	Severe damage	0.9-0.8	10-20

Table 2. Blast damage adjustments in MBR (after Bieniawski, 1984)

Ouchterlony et al. (1991) observed that the damage zone could be to the extent of 0.5 m with cautious tunnel blasting. McKenzie (1994) related the threshold peak particle velocity PPV ( $v_{max}$ ) for incipient fracture with uniaxial tensile strength ( $q_t$ ), Young's modulus and P-wave velocity ( $V_p$ , m/s) as shown below:

$$v_{max} = \frac{q_t \times V_p \times 10^{-3}}{E}, \text{ m/s} \quad (3)$$

where

$q_t$  = uniaxial tensile strength, MPa,

$V_p$  = P-wave velocity, m/s, and

$E$  = Young's modulus, GPa.

Pusch and Stanfors (1992) and others observed that the minimum disturbance by blasting is reported when the tunnel orientation was within 15° with the strike of the joint sets.

Yu and Vongpaisal (1996) concluded that the damage is a function of blast induced stress and rock mass resistance to damage. They proposed Blast Damage Index ( $D_{ib}$ ) to estimate the type of damage due to blasting. It is the ratio of the blast induced stress to the resistance offered against damage.

Ramulu et al (2009) categorised blast induced damage as,

- near-field damage due to high frequency and critical vibrations
- far-field damage due to repeated low frequency and sub-critical vibrations. Ramulu and Sitharam (2011) assessed the near-field damage by using vibration attenuation model of charge weight scaling law and dynamic tensile failure criteria instead of conventional Holmberg-Persson model (1979) and static tensile failure criteria. Ramulu (2010) correlated the far-field damage with shear wave velocity of rock mass and found the following equation with reasonably good correlation coefficient ( $R^2=0.76$ ).

$$D_{\max}=322.5(V_s)^{-0.61} \text{ m} \quad (4)$$

where,

$D_{\max}$  - Maximum extent of rock mass damage due to repeated vibrations, m

$V_s$  - S-wave velocity, m/s

## 6. Contour blasting

Contour blasting in tunnelling is adopted to obtain a smooth tunnel profile and minimise damage to the surrounding rock mass. Despite a large amount of drilling required, it is preferred over conventional blasting because of the following advantages:

- i. The shape of the opening is maintained with smooth profile.
- ii. Stability of the opening and the stand-up-time of the tunnel are improved.
- iii. Support requirement is reduced.
- iv. Overbreak is reduced to minimise unwanted excavations and filling to bring down the cost and cycle time.
- v. Ventilation improves due to smooth profile.

The performance of contour blasting is frequently measured in terms of 'Half cast factor' (HCF) which is dominated by the design parameters of the contour holes, the joint orientation and the explosive energy distribution.

Generally, two types of contour blasting are used in tunnelling, i) pre-splitting and ii) smooth blasting. When two closely spaced charged holes are fired simultaneously the stress waves generated from the two holes collide at a plane in between the holes and create a secondary tensile stress front perpendicular to the hole axis and facilitates extension of radial cracks along the line joining the holes. The wedging action from the explosion gas acts in favour of extending the crack along the same line. It is, therefore, essential to contain the gas pressure till the cracks from both ends meet by adequate stemming. Further, the delay timing of the adjacent holes need to be very accurate so that the stress waves should collide at the mid-point and the arbitrariness of the breakage between the holes can be reduced.

The contour blasting performance largely depends on the nature and the orientation of joint planes. Gupta et al. (1988) found that the joint orientation adversely influences the pre-splitting results to a maximum when these are at an angle of  $1-30^\circ$  to the pre-split axis.

In smooth blasting, the delay intervals between the contour holes and the nearest production holes are kept high to facilitate complete movement of material in production holes before the contour holes detonate so that the gas expansion in contour holes occurs towards the opening. Sometimes, holes are drilled in between two charged blast holes and are kept uncharged. These are called dummy holes (Figure 1). The stress concentration at the farthest and the nearest points of the dummy holes become high to initiate cracks from the dummy holes extending towards the charged holes. The fracture is, thus, controlled along the desired contour.

In some cases, slashing or trimming techniques are used where the central core of excavation area is removed first to reduce the stress and then post-splitting is adopted to remove the remaining rock mass along the desired contour. The technique is generally referred to as 'slashing' or 'trimming' [Calder and Bauer (1983), Figure 2].

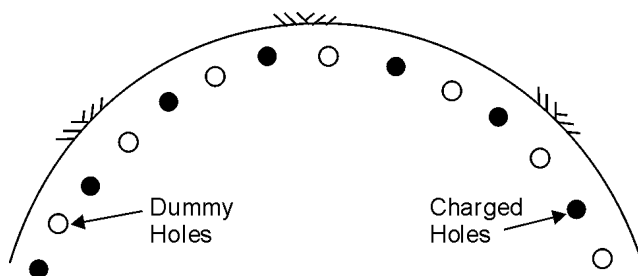

Fig. 1. Smooth blasting pattern with dummy holes

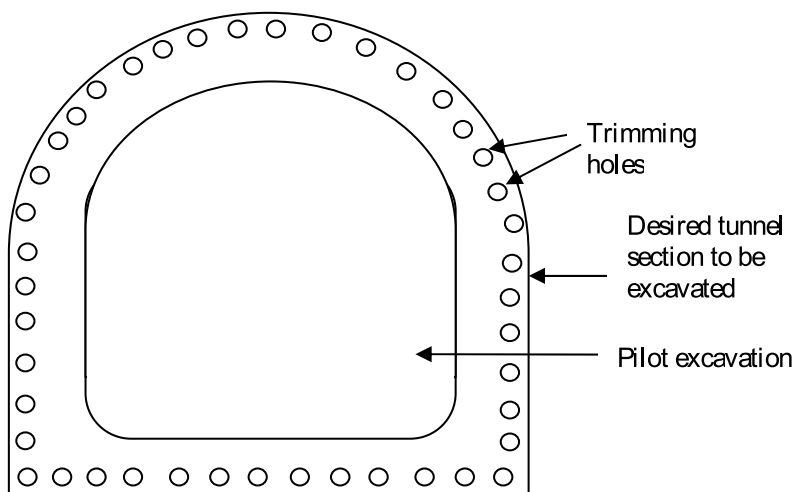

Fig. 2. Cushion blast holes for trimming of a tunnel after pilot excavation

Line drilling is adopted as an alternative technique where a number of uncharged holes are drilled along the contour with a spacing of 2-4 times the hole diameter (Du Pont, 1977). The distance of the row of empty holes from the final row of charged holes is kept as 0.5-0.75 times the normal burden. The empty holes are joined during the main blasting round and a separation is created along the contour.

According to Holmberg and Persson (1978), the spacing of pre-split holes should be 8-12 times the blast hole diameter. The following design parameters for contour hole spacing, burden to spacing ratio of contour holes and linear charge concentration in smooth blasting are suggested by Holmberg (1982) :

$$S_{dc} = 16 \times d_b, \text{ m} \quad (5)$$

$$m_{dc} = 1.25 \quad (6)$$

$$q_{lcc} = 90 \times (d_b)^2, \text{ kg/m} \quad (7)$$

where

$S_{dc}$  = spacing of contour holes while drilling, m,

$m_{dc}$  = burden to spacing ratio of contour holes while drilling,

$q_{lcc}$  = linear charge concentration in the contour holes, kg/m, and

$d_b$  = diameter of blast holes, m.

Controlled blast design details recommended by Olofsson (1988) are presented in Table 3.

Type of Blasting	Blast Hole Diameter (mm)	Spacing of Blast Holes (m)	Burden (m)	Linear Charge Concentration (kg/m)
Smooth blasting	25-32	0.25-0.35	0.3-0.5	0.11
	25-48	0.5-0.7	0.7-0.9	0.23
	51-64	0.8-0.9	1.0-1.2	0.42-0.45
Pre-splitting	38-44	0.3-0.45	-	0.12-0.37

Table 3. Recommended blast design for contour blasting (Olofsson, 1988)

## 7. Special tunnel blasting techniques

Some special blasting techniques were practised in tunnels and underground coal mine to attain greater advance and better safety in some critical working sites under the recommendations and supervision of Central Mining Research Institute, Regional Centre, Nagpur. Those cases are discussed in brief in the following paragraphs.

### 7.1 Long hole raise driving by blasting

A 123 m deep pilot shaft was excavated in 95 days time using Long Hole Raise Blasting (LHRB) method for faster and safer shaft sinking in the surge shaft, passing through various kinds of basaltic formations, in Ghatghar Hydro-electric Project of Maharashtra. The blast hole charging pattern is shown in Figure 3. Application of this techniques resulted in saving of 75% time 60% cost of excavation in comparison to the conventional shaft sinking method.

A ventilation shaft of 40m depth was also excavated by using the same technique at diversion tunnel of Latur-Osmanabad Railway tunneling project of Central Railways in 20 days. This techniques yielded in saving of time by 80% and cost of excavation by 60% in comparison to the conventional shaft sinking method, which mainly suffer from weather effects, confined working space and low cycle time.

Similarly, a pilot surge shaft of 3.0m diameter130m depth was excavated by long hole raise driving technique at a lift irrigation scheme of Koilsagar project. This swift and cost effective shaft excavation technique was completed in just 60 days with cost savings of 70% and time saving by 95% in contrast to conventional shaft sinking method. The profile of excavated pilot surge shaft at Koilsagar project is shown in Figure 4.

## 7.2 Lake tap blasting

The lake tapping of fist of its kind with indigenous technology was carried out in India by CMRI (now CIMFR) at granitic rock mass in South India. The Andhra Pradesh Power Generation Corporation (APGENCO), India, executed a lift irrigation scheme (SLBC) for the Government of Andhra Pradesh to install 4 Nos. of 4 x 25000 hp pumps to lift 2400 cusecs of water from the Nagarjuna Sagar reservoir for irrigation purpose. A 4 m thick rock plug, designed by CMRI, was left for lake tapping at the end of project. The area of cross section of the tunnel was 40 m<sup>2</sup>. Considering proximity of the nearby structures a controlled blast strategy in phased manner was evolved prior to final plug blasting. Vibration and damage characteristics were ascertained to finalise the blast design of the final plug.

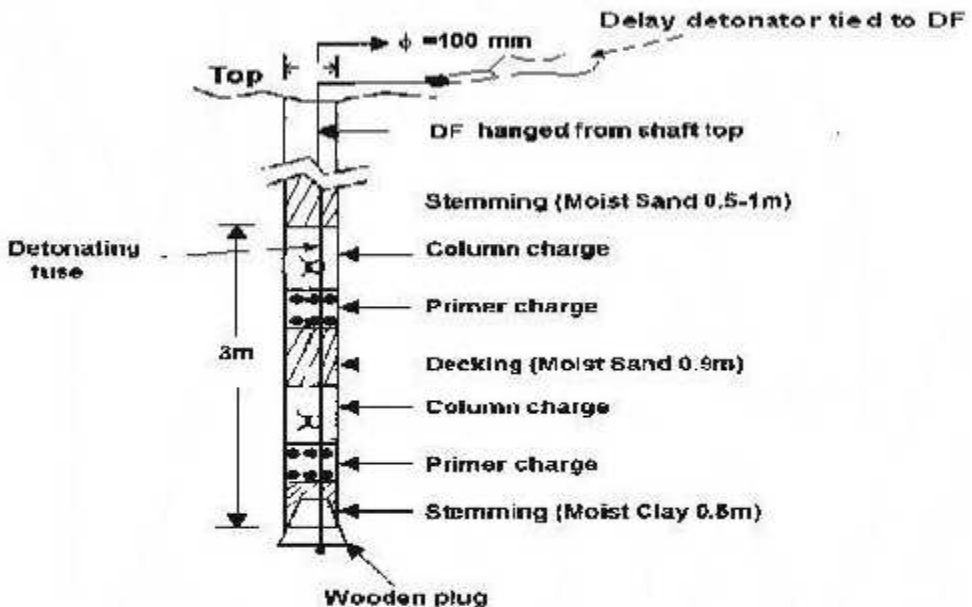

Fig. 3. Charging pattern in raise blasting





Fig. 4. Profile of pilot surge shaft excavated by long hole raise driving at Koilsagar

Based on the blast performance of the trail rock plug final plug blast design was made with the following salient features:

- Specific charge was increased from  $1.25 \text{ kg/m}^3$  to  $1.33 \text{ kg/m}^3$  to improve throw and fragmentation.
- Only gelatine explosive was recommended considering the water inflow from the blast holes.
- Dummy holes were made above the crown holes, at a distance of 0.3 m, to minimise rock mass damage.
- A borehole from the top was used to convey initiation to the blast holes.

The final plug-blasting pattern is shown in Figure 5. This novel technology being an indigenous one could save Crores of national exchequers.

### 7.3 Cautious blasting

By adopting an extremely cautious approach, all 10 reinforced concrete plugs, each of 125 m<sup>3</sup> volume, in 5 units were removed by controlled blasting without causing any damage to the surrounding periphery and pier nose in Srisailam left bank project of the APPGENCO while the power house was in running condition. The controlled blasting pattern is described below:

- i. Line drilling holes of 1.5m depth were drilled with spacing of 0.15 m between the holes on the pier nose side and at 0.20 m inside the periphery.
- ii. The periphery holes were pre-split with air-decking. The half cast factor of the periphery blasting was around 95%, which indicates low damage level. The pre-split blasting connections and the post-blast wall with half cast holes are shown in Figures. 5(a) and 5(b).
- iii. A cut was created at the heading and it was widened and deepened to make a pilot hole in the plug along its axis.
- iv. The balance concrete mass of the heading was slashed with less charge against the void.
- v. The bottom was blasted with benching method.
- vi. Mucking was done by mechanical and manual means.
- vii. Continuous blast vibration monitoring was carried out during the blasts at near, intermediate and far field.
- viii. Analysis of vibration data was done for subsequent blasting and to develop general predictor equation.

Pre and post blast ultrasonic measurements were taken at the exposed areas of the pier nose walls to know the change in physical property the reinforced mass due to blasting. The compressional wave velocities (P-wave) were measured by Roop telesonic ultrasonix instrument 'Ultrasonix 4600' which is shown in Figure 6. The average P-wave velocity was 2075 m/s and 2100m/s before and after blasting respectively. The values indicate that there has been no blast-induced damage to the structure under consideration.

The cautious blasting was also applied at Koldam Hydroelectric Power Project (KHEPP) to reduce overbreak and to get a smoother tunnel wall profile. The rock mass encountered in all the tunnels of KHEPP was Dolomite, which was very heterogeneous, highly weathered, metamorphosed, compact, foliated, sheared and crushed due to the effect of Chamiatar Khad fault striking N1700 E and 450 W. Joints are open, closely spaced, intersecting, which are having clay fillings due to mechanical and chemical weathering of the rocks. One main joint with angle of N 750 E/800W is running parallel to the axis of the tunnels which is very unfavourable. At some places huge wedges were formed due to the intersection of the joints, which caused excessive overbreaks in the tunnels. The Q values of most of the rock mass of tunnels range from 0.12 to 0.21, which indicates that the rock was very poor. Core samples were collected from both the monitoring locations by underground coring machine. Engineering properties like Rock Quality Designation (RQD) compressive strength, tensile strength, density and compressional wave velocity (V<sub>p</sub>) were determined from the core samples.

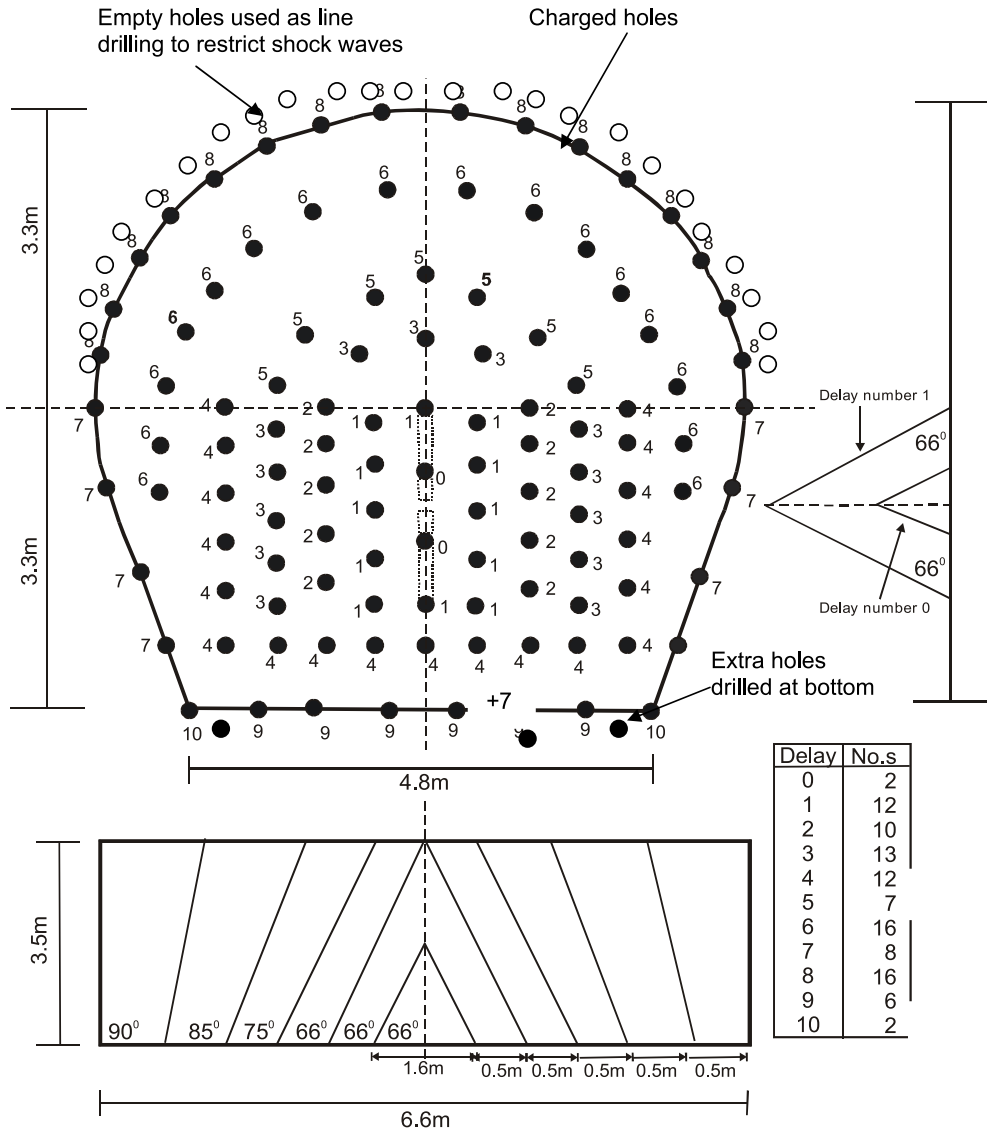

Hole Diameter = 32 mm; Total no.of blast holes = 113,  
 Length of blast holes = 3.5 to 4.0 m,  
 Specific Charge = 1.33 kg/m<sup>3</sup>

Fig. 5. Lake tap blast design

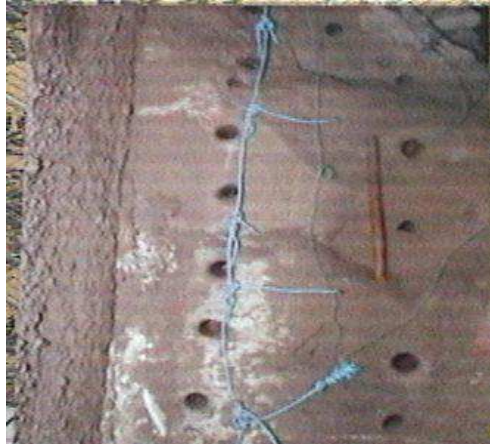

Fig. 5(a). Connections for pre-split blasting



Fig. 5(b). Pier nose wall after pre-split blasting



Fig. 6. Compressional wave velocity (P-wave) measuring device 'Ultrasonix 4600'

In-situ compressive strengths were also determined by using Schmidt hammer rebound testing. The average RQD values of Dolomite rock mass ranging from of 40-60%. Water absorption properties measured at the test site was 1.2% at both the sides. The improved blast performance of smooth blasting in the form of smooth profile is shown in Figure 7. The results were consistent for 12 trial blasts at the Dolomite tunnel. The controlled blasting restricted the overbreak to only 3%, which was 27% with the conventional tunnel blasting. The average half cast factor was calculated as 85%.



Fig. 7. Improved blast performance of smooth blasting in the form of smooth profile at KHEPP

#### 7.4 In-hole delay blasting

Following the trend of opencast blasting, in hole delay blasting technique using delay electric detonators were used in some mines and tunnels to improve the pull per blast and reduce the ground vibration. As the confinement in the cut holes are maximum and the blast performance in tunnels depend mainly on the development of the cut portion, the in-hole delay were used in the cut holes only. The salient features of the in-hole delay pattern are:

1. The collar portion of the hole was blasted prior to the bottom. Thus, the confinement at the hole bottom was less during firing.
2. Mid-column decking between the two charges in a hole was kept at least 0.6 m to avoid sympathetic detonation. This decking provided confinement for the bottom charge.

The charging pattern is explained in Figure 8.

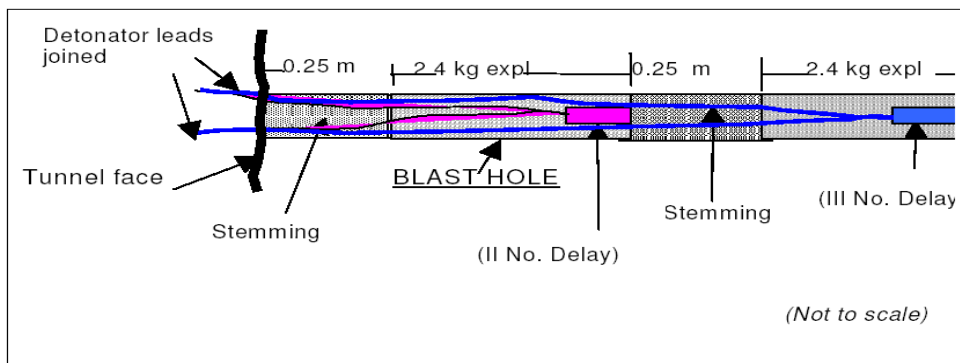

Fig. 8. Charging pattern of cut holes with in-hole delay

This technique was successfully applied at basaltic rock mass of Central railway tunnels and gneiss rock mass of Lohari Nag Pala Hydel power project.

The advantages of the in-hole delay cut blasting includes:

1. The average face pull improve by nearly 30-50%. The specific charge also reduces proportionately.
2. The blast vibration intensity reduces by 20 to 25% as the cut hole charge is distributed in two delays. This is going to reduce the overbreak proportionately.

### 7.5 Bottom hole decking technique

The mining industry is striving to enhance the productivity by improving fragmentation to reduce the system cost. In order to achieve this objective, development of new techniques and their application is essential. The authors at CIMFR, experimented a blasting technique called 'bottom hole decking technique' to achieve the objective of blasting productivity improvement of the mining industry. The technique consists of air decking at the bottom of the blasthole in dry holes by means of a wooden spacer or a closed PVC pipe. Although, practice of air decking is not new thing in blastholes, the concept of inserting bottom hole decking below the explosive column is relatively new. Explosives provide a very concentrated source of energy, which is often well in excess of that required to adequately fragment the surrounding rock material. Blast design, environmental requirements and production requirement limits the degree to which the explosive energy distribution within the blasthole can be significantly altered using variable loading techniques. Use of air-decks provide an increased flexibility in alteration and distribution of explosive charge in blast holes.

The bottom hole air-decking was developed to avoid the general disadvantages of middle air decking and to simplify the complex charging procedure, associated with it. The design aspects of the technique are explained in the following sections. The bottom hole decking consists of air decking at the bottom of the hole in dry holes by means of a spacer or a closed PVC pipe, covered at the upper end. The fume characteristics of the spacer are to be tested before applying in underground coal mine. If blast holes are wet, water decking will be created at the bottom by means of a spacer with a weight attached to it for sinking to the

bottom. The diameter of the spacer should be preferably one third of the blasthole diameter for easy lowering and not allowing the charge to go to bottom side while loading. The reported values of air-deck length was taken as basis for optimum bottom deck length which was about 10% of the hole depth (Mead et al, 1993). The hole contains explosive and stemming column as in conventional loading but with a spacer at the bottom. The principle of bottom hole air decking in achieving optimum explosive energy interaction on rock mass is given below:

- Reduced shock energy around the blast hole due to cushioning effect of air decking, which otherwise would result in crushing
- Explosive energy-rock interaction is more at the bottom due to relative relief zone existing at that zone.
- Effective toe breakage is due to striking and reflection of shock waves at the bottom face of hole

The procedure and sequence of blast hole loading and initiation for the bottom hole decking are given below:

- Inserting the spacer in to the hole bottom by stemming rod.
- Loading the primer explosive cartridge attached by delay detonator charging the column charge conventionally
- Stemming of the hole by proper stemming material, preferably by sand mixed clay

The advantages of the bottom air decking technique in comparison to the conventional middle air decking are given below:

- The highly confined toe is free of explosive charge but exposed to high concentration shock energy, resulting in good toe breakage and low vibration intensity.
- The reduced overall peak shock reduces the back break and damage.

Blast hole charge design for production blasts with bottom air-decking is Figure 9.

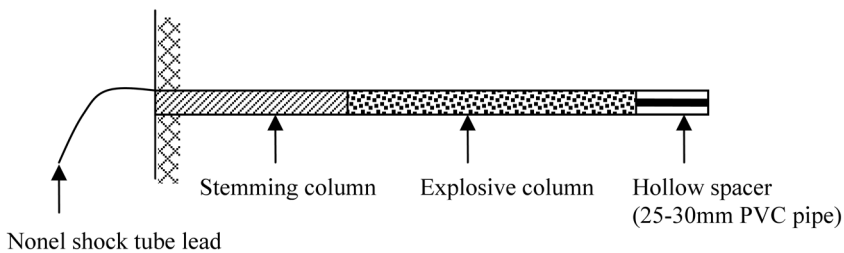

Fig. 9. Blast hole charge design for production blasts with bottom air-decking

The bottom air decking also resulted in the overall progress/pull per round of 36% with 1.5 deep rounds and 22% with 1.8 m deep rounds even with the powder factor improvement (ton/kg) upto 70%. The increase of detonator factor was very predominant in case of tests with bottom decking in comparison to tests with bottom decking technique. The technique was also resulted in reduction of ground vibrations by 20-26%. The laboratory and field experimental results prove that the bottom-hole air decking is an effective technique for improving the opencast blasting productivity as well as safety.



## 8. Sand stemming device for horizontal blast holes

The device of sand stemming for horizontal blast holes constitutes an assembly of a plastic pipe with proper cut and slits, a wooden block with pulley arrangement for resisting sand and an anti-static (non metallic) rope to pull out the plastic pipe from blast hole. The device essentially consists of a plastic pipe tied with an anti-static rope which is passed through a wooden resisting block to which a pulley is attached. The main objective of the device is for efficient use of sand as stemming material in horizontal blast holes. Another objective of the present device is to provide an effective and economic and fast stemming method which can find a mass application in underground blasting. The device essentially consists of a plastic pipe tied with a non metallic rope which is passed through a wooden resisting block to which a pulley is attached, an assembly of a plastic pipe cut and slit properly and a rope passed through a wooden block which can insert the sand in to blast hole and resist the sand to come out while pipe is pulled out of the blast hole. The position of stemming device while inserting the sand with plastic pipe and the position of removal of the plastic pipes are shown in the Figure 10. Actual application of the device in the field is shown in the Figure 11.

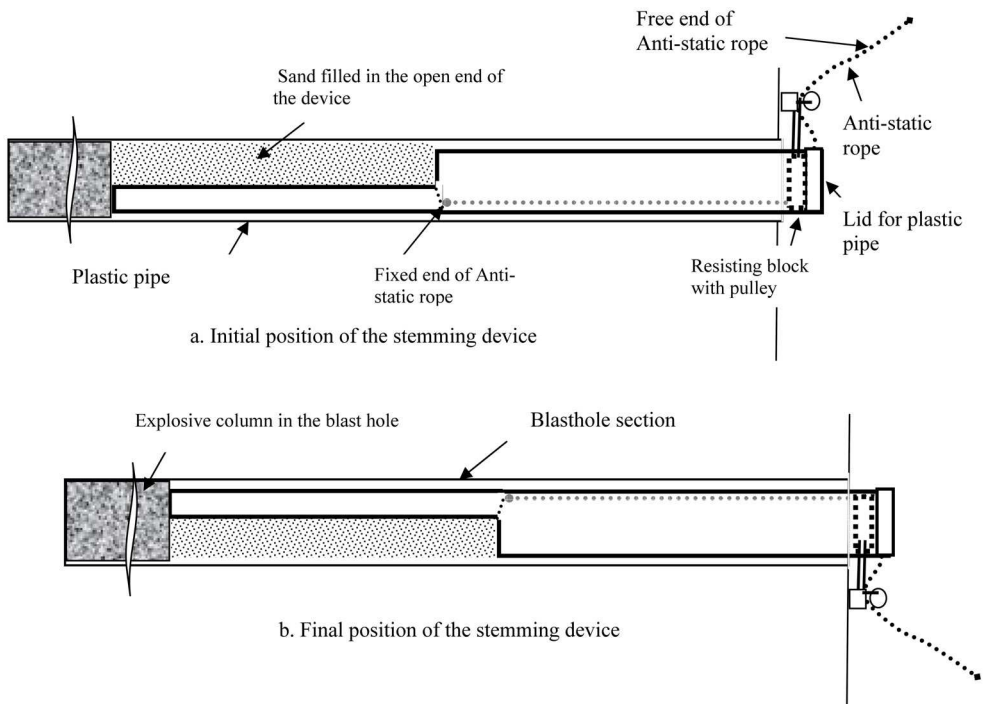

Fig. 10. Position of stemming device for loading and unloading in the blasthole.

Application of this tool in place of conventional stemming resulted in pull improvement of 5-10% in dolomite tunnels and 8-12% in gneiss tunnel. The improved blast performance was recorded consistently for 20 trial blasts at the gneiss tunnels and 25 trial blasts at the dolomite tunnels.





Fig. 11. Loading and unloading of sand into the stemming column of a blasthole at KHEPP

### 9. Computer aided blast design

Some of the software developed for blast design and optimisation are reported in Table 4. Few blasting software on tunnel blasting are commercially available and the details can be obtained through web search.

Name of Software	Purpose	Reference
OPTES	Blast optimisation in tunnels	Vierra (1984)
VOLADOR	Estimation of blast results, blast efficiency and cost analyses in tunnels	Rusilo et al. (1994)
TUNNEL BLAST	Blast design in tunnels	Chakraborty et al. (1998)
CAD	Optimum design of ring hole blasting	Myers et al. (1990)
FLAC and UDEC	Blasting effects on the near field rock mass	Pusch et al. (1993)
ABAQUS V 5.4	Mechanics of crater blasting and the effects of air decking and decoupling	Liu and Katsabanis (1996)
ALEGRA	Air-decking blasting	Jensen and Preece (1999)
PFC-2D/3D	Crack and heaving simulation	Itasca Consulting Group Inc. (2002)
Neural networking	Model free computing	Leu S. S. et al. (1998)

Table 4. Various routines for computer aided tunnel blast design

## 9.1 TUNNEL BLAST<sup>2.0</sup> software

Based on the past experience and extensive field investigations over a variety of underground structures of varying lithologies, CMRI Nagpur Centre devised a software "TUNNELBLAST" for generating blast design for Tunnels and underground workings. This software is a handy intelligent tool for the site engineers to optimise the blasting process and improve productivity without spending their valuable time on scrutinising variety of documents, books and literature available. The software is simple to operate and user friendly. The input and output parameters of the software are as under:

Input parameters:

1. Rock properties (density, compressive strength and joint spacing),
2. Tunnel (shape, width and height),
3. drilling (diameter and length of blast hole), and
4. Explosive properties (weight strength, weight and length of cartridge).

Output parameters:

1. Size of the tunnel,
2. Probable deviation of blast holes,
3. Optimum depth of round,
4. Look out angle of peripheral holes,
5. Burden, spacing and charge of holes in cut area, floor periphery and in the middle of the tunnel section,
6. Front and sectional views of the blast pattern

## 9.2 Field application of TUNNEL BLAST software at gneiss rock mass

The TUNNEL BLAST software was applied to design the parallel cut blast pattern at Lohari-Nag Pala Hydroelectric Power Project (LNPHPP). The LNPHPP falls in the Uttarakhand Himalayas and is located on the River Bhagirathii upstream of Uttarkashi district. The main rock type of powerhouse complex is schistose gneiss and augen gneiss with abundance of mica and geotechnically the rock mass is negotiating in "Fair Category" and it's having three prominent joint sets. The Rock Mass Quality (Q) was varying from 1-10. The main two joint sets intersecting at right angle which makes wedge continuously. Some weak zone/clay filling, altered rock, sheared rock mass and excessive flow of water at places makes the rock poor. In maximum area it is found that the regional trend of foliation is perpendicular to the tunnel alignment, another joint which is intersecting the foliation at right angle and creates wedge on roof. The strike of the foliation is going through along the tunnel alignment which is geologically not favourable because of probabilities of plane failure and wedge failure in presence of heavy joint planes.

The input geological parameters required for the blast design software are as follows:

Rock type	Metabasic (Amphibolite) & quartz vein
Joint sets	Three + Random (045 <sup>0</sup> /35 <sup>0</sup> , 210 <sup>0</sup> /45 <sup>0</sup> , 130 <sup>0</sup> /80 <sup>0</sup> )
Critical joint	045 <sup>0</sup> /35 <sup>0</sup> , 210 <sup>0</sup> /45 <sup>0</sup>
Water Condition	Dry
Weathering	Highly Weathered/Fractured
Filling	Clay seam, width 10-20cm

Boundary conditions:

- Rock Type: Metabasic (Amphibolite) & quartz vein
- Av. rock density:  $2.6 \text{ t/m}^3$
- Type of explosives: Emulsion
- Blast hole diameter: 45 mm
- Explosives diameter: 40 mm & 32 mm
- Explosives strength: 80% (60% may also be required in the periphery holes and hence provisions may be made)
- Length of blast hole: 2 m
- Delay: Long delay (NONEL)

After feeding the input information the software process the entire data and gives the blast hole geometry and charge pattern for cut holes and other holes separately. The output information given by TUNNELBLAST software is given in Figure 12, Figure 13 and Table 5 and Table 6.

The blast design generated by TUNNEL BLAST software was applied at intermediate adit and the blast results were satisfactory in terms of pull per round and overbreak control. The trial blast results with felid application of TUNNEL BLAST software are given in Table 7. The blast results indicate the efficacy of the TUNNEL BLAST software, as a preliminary tool for tunnel blast design for various geological conditions. The fine tuning of this design can be done for further improvements in the progress and yield of tunnel blasting.

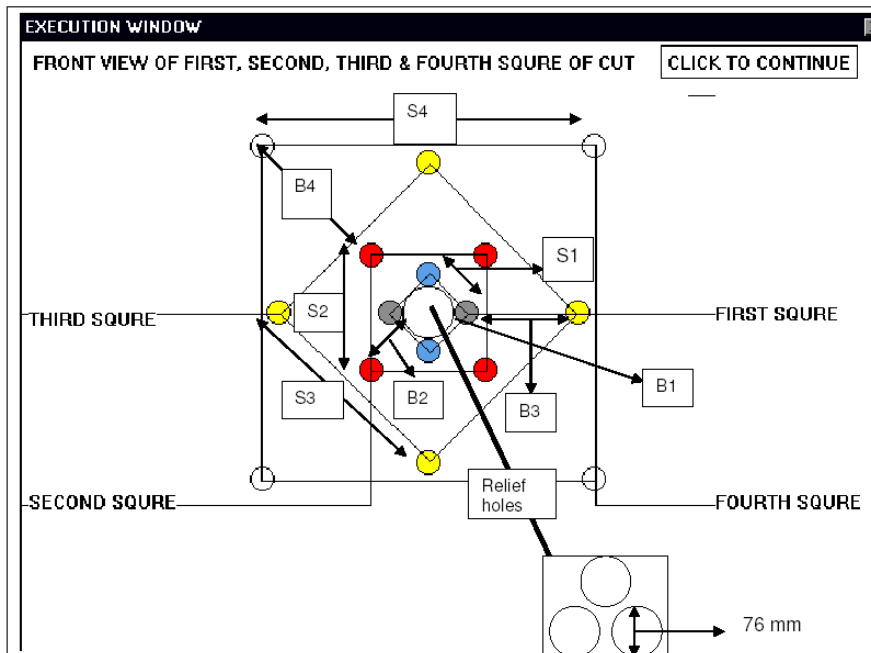
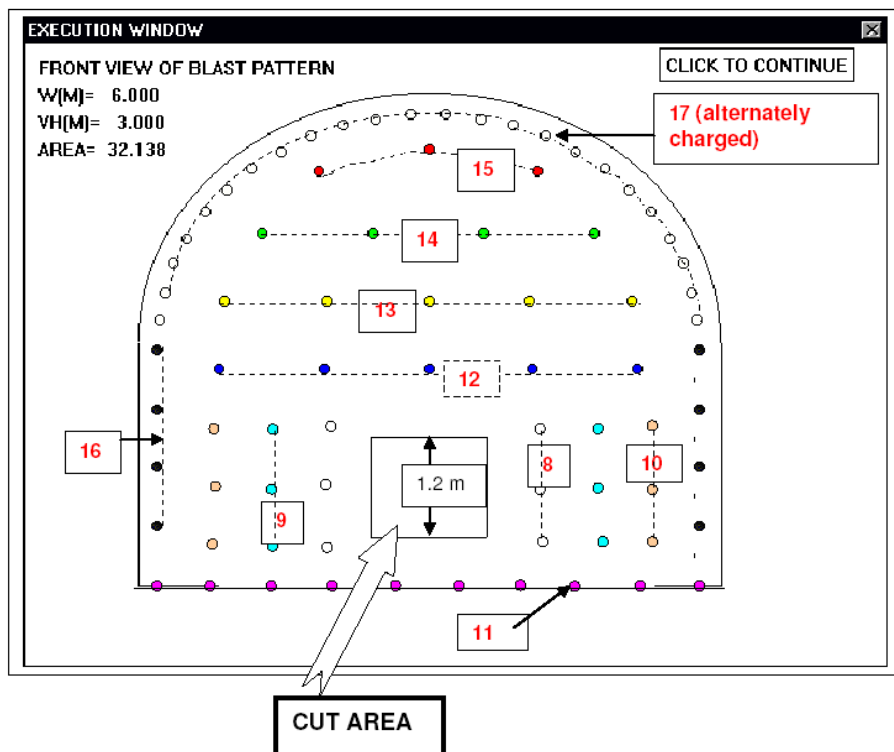

Fig. 12. Blast design output from TUNNELBLAST for cut holes of intermediate adit



Nos. in the boxes denote the delay numbers; Total Charge per round = 97.7 kg  
 Total no. of holes= 3-Relief holes + 69-Charged holes+ 12-Dummy holes; Powder factor = 1.52 kg/m<sup>3</sup>

Fig. 13. Controlled blast design output from TUNNEL BLAST for rest of the holes at intermediate adit of LNPHPP

Short Delay No. (25 ms delay)	Name of square	Burden, m	Spacing, m	No. of holes	Charge/hole, kg	Total charge, kg
1	First	0.15	0.2	4	1.2	4.8
2/3	Second	0.20	0.4	4	2.4	9.6
4/5	Third	0.35	0.75	4	2.4	9.6
6/7	Fourth	0.45	1.2	4	2.4	9.6

Table 5. Blast pattern and charge configuration of the cut holes

Description of holes	Delay No.	No. of holes	Burden	Spacing	Charge per hole (kg)	Total Charge/delay (kg)
Easer holes	8	6	0.6	0.75	0.95	5.7
Support holes	9	6	0.6	0.75	0.95	5.7
Support holes-II	10	6	0.6	0.75	0.95	5.7
Bottom Holes	11	10	0.4	0.70	1.8	18
Crown Holes-I	12	5	0.8	1.2	1.6	8
Crown Holes-II	13	5	0.8	1.2	1.6	8
Crown Holes-III	14	4	0.8	1.2	1.6	6.4
Crown Periphery holes	15	3	0.6	0.3	0.6	1.8
Side Periphery holes	16	8	0.6	0.3	0.6	4.8

Table 6. Design and charging details of blast holes, other than cut holes

S No.	Location	Hole diameter, mm	Depth of holes, m	No. Of holes	Charge per round, kg	Specific charge, kg/m <sup>3</sup>	Pull/round, m
1	Downside, TRT	40	3.5	91	217	2.1	1.98
2	Upside, TRT	40	3.5	89	225	1.85	3.1
3	Upside, TRT	40	3.5	89	250	1.98	3.0
3	Downside, TRT	40	3.5	91	220	2.0	1.95

Table 7. Trial blast results with felid application of TUNNEL BLAST software

## 10. Conclusions

The reviews on the developments in rock mass damage and contour blasting brings an important information on field application of controlled blasting and damage assessment and control. The contributions of CIMFR on special tunnel blasting techniques resulted in improvement of both productivity and safety. The following conclusions can be drawn based on the various topics discussed in the paper:

- i. Application of this techniques resulted in saving the time of 75-80% and cost of 60%-95% in comparison to the conventional shaft sinking method at three different projects
- ii. Lake Tap Blasting of a 4 m thick 40 m<sup>2</sup> cross sectional area was carried out as of first of its kind with indigenous technology in India by CMRI (now CIMFR) at granitic rock mass in Andhra Pradesh Power Generation Corporation (APGENCO), which could save Crores of national exchequer.
- iii. Ultra cautious blasting techniques were adopted as an extremely cautious approach, for removal of 10 reinforced concrete plugs, each of 125 m<sup>3</sup> volume, without causing any

- damage to the surrounding periphery and pier nose in Srisailam left bank project of the APPGENCO while the power house was in running condition.
- iv. Successful application of in-hole delay cut blasting method at basaltic rock mass and gneiss rock mass improved average face pull improve by nearly 30-50%. Blast vibration intensity reduces by 20 to 25% which resulted in reduction of the overbreak proportionately.
  - v. Bottom hole decking technique resulted in the overall progress/pull per round of 36% with 1.5 deep rounds and 22% with 1.8 m deep rounds even with the powder factor improvement (ton/kg) upto 70%.
  - vi. Application of sand stemming device for horizontal blast holes in place of conventional stemming resulted in pull improvement of 5-10% in dolomite tunnels and 8-12% in gneiss tunnel.

## 11. References

- Bieniawski, Z. T., (1993). Classification of rock masses for engineering: the RMR system and future trends. In J.A. Hudson (Ed.), *Comprehensive rock engineering: principles, practice, and projects*, Oxford: Pergamon Press. V.4, pp. 553-573
- Calder, P. N. and Bauer, A. (1983). Presplit blast design for open pit and underground mines, *5<sup>th</sup> International Cong. on Rock Mechanics*, Melbourne, Vol. 2, pp. E185- E190.
- Chakraborty, A. K. (2002). Development of predictive models for optimum blast design in mine roadways and tunnels under various rock mass conditions, *Ph.D. Thesis, Indian School of Mines, Dhanbad, India*, 298 p.
- Chakraborty, A. K., Jethwa, J. L. and Dhar, B. B. (1996b). Predicting powder factor in mixed-face condition: development of a correlation based on investigations in a tunnel through basaltic flows, *Engineering Geology*, Elsevier Science B.V., Netherlands, No. 47, pp. 31-41.
- Chakraborty, A. K., Murthy, VMSR and Jethwa, J.L. (1996a). Blasting problems in underground construction through Deccan Trap formation: Some experiences at Koyna Hydro-electric Project, Stage IV , *Tunnelling & Underground Space Technology*, Elsevier Science Ltd., Great Britain, Vol. 11, No. 3, pp. 311-324.
- Chakraborty, A. K., Murthy, VMSR, Jhanwar, J. C., Raina, A. K., Ramulu, M. and Jethwa J. L. (1998). Final report on Development of Rock Mass Classification for Computer Aided Tunnel Blast Design, *Grant-in-Aid Project funded by Ministry of Water Resources, Govt. of India*, 136 pp.
- du Pont, E.I., (1977). *Blasters hand book*, 175<sup>th</sup> Anniversary edition, E.I. du Pont de Nemours, Inc., Wilmington, Delaware. Pp.526-541.
- Duvall, W. I. and Atchion, T. C. (1957). Rock breakage by explosives, USBM, RI 5356, Explosives Reference Database on CD-Rom, *International Society of Explosives Engineers*, Ohio, USA, 1997.
- Gupta, R. N., Singh, R. B., Adhikari, G. R. and Singh, B. (1988). Controlled Blasting for Underground Excavation, *International Symposium on Underground Engineering*, 14-17 Apr., New Delhi, India, pp. 449-460.
- Holmberg, R., and Persson, P. A. (1978). The Swedish approach to contour blasting, Proc. of Annual Conference on Explosives and Blasting Research, Explosives Reference Database on CD-Rom, *International Society of Explosives Engineers*, Ohio, USA, 1997.

- Itasca Consulting Group Inc. (2002). Particle Flow Code in 2 Dimensions - Theory & Background, Minneapolis, USA. p. 1.1-1.28.
- Jensen, R. P. and Preece, D. S. (1999). Modelling explosive/rock interaction during pre-splitting using ALE computational method, *Proc. 6<sup>th</sup>. International Symposium for Rock Fragmentation by Blasting*, The South African Inst. of Mining and Metall., Johannesburg, Aug. 8-12, pp. 199-202.
- Johansen, J. (1998). Modern trends in tunnelling and blast design, IDL Industries Ltd., Hyderabad, India, pp. 34-41.
- Langefors, U. and Kihlstrom, B. (1973). *The Modern Technique of Rock Blasting*, John Wiley & Sons, pp. 188-257, 299-301.
- Leu S. S., Lin S. -F., Chen C. -K. And Wang S. -W. (1998). Analysis of powder factors for tunnel blasting using neural networks, *The Int. Journal for Blasting and fragmentation*, Balkema A. A. , Netherlands, Vol. 2., No. 4, pp. 433-448.
- Liu, L. and Katsabanis, P. D. (1996). Numerical modelling of the effects of air-decking/decoupling in production and controlled blasting, *Proc. 5<sup>th</sup> International Symposium on Rock Fragmentation by Blasting, FRAGBLAST-5*, Montreal, Quebec, 25-29..pp. 319-330.
- Livingston, C. W. (1956). Fundamentals of rock failure, *Quarterly of the Colorado School of Mines*, Vol. 51, No. 3, Jul..
- Lopez Jimeno, C., Lopez Jimeno, E., Carcedo, F. J. A. and De Ramiro, Y. V. (1995). *Drilling and Blasting of Rocks*, Balkema A. A., Rotterdam, pp. 200-204 and 259-260.
- McKenzie, C. J. (1994). *Blasting for Engineers*, Blastronics Pty. Ltd., Brisbane, Australia.
- Olofsson, S., O. (1988). *Applied Explosives Technology for Construction and Mining*, Applex, Arla, Sweden, 303 pp.
- Ouchterlony, F., Nyberg , Sjoberg, C., Johansson, S-E. (1991). Damage zone assessment by vibration measurements, *Aspo hard rock laboratory*, Progress Report , No. 3, pp. 25-91.
- Pokrovsky, N. M. (1980). *Driving Horizontal Workings and Tunnels*, Mir Publishers, Moscow, pp. 38-41.
- Pusch, R. and Stanfors, R. (1992). The zone of disturbance around blasted tunnels at depth, *International Journal Rock Mech. Mining Sci. & Geomech. Abstr.*, Vol. 29, No. 5, pp. 447-456.
- Pusch, R., Hokmark, H. and Borgesson, L. (1993). Characterisation of structure and stress state of nearfield rock with respect to the influence of blasting, *Proc. 4<sup>th</sup> International Symp. on Rock Fragmentation by Blasting, FRAGBLAST-4*, Vienna, Austria, pp.175-181.
- Ramulu, M., (2009), Rock mass damage due to repeated blast vibrations in underground excavations, IISc Dept.of CE PhD Thesis- G23635, 624.15132 P09, IISc Press.
- Ramulu, M., Chakraborty A. K. and Sitharam T.G., (2009), Damage assessment of basaltic rock mass due to repeated blasting in a railway tunnelling project - a case study, *Tunnelling and Underground Space Technology*, Vol.24, pp. 208-221.
- Ramulu, M., Sitharam, T.G., (2011), Blast induced rock mass damage In underground excavations -Applications to civil engineering projects, LAMBERT Academic Publishing GmbH& Co. KG, 66123 Saarbrücken, Germany, ISBN (978-3-8433-9318-8)

- Rusilo, L. C., Sansone, E. C., Hennies, W. T. and Ayres Da Silva, L. A.(1994). Design and optimization of tunnel blasting operations, *Proc. 3<sup>rd</sup> International Symposium on Mine Planning and Equipment Selection*, Istanbul, Turkey, 18-20 Oct., pp. 651-655.
- Singh, S. P. (1995). Mechanism of cut blasting, *Trans. Inst. Mining and Metall., Section A, Mining Industry*, Vol. 104, Sept-Dec., *The Inst. of Mining and Metall.*, U.K., pp. A134-A138
- Wilson, W. H. (1987). An experimental and theoretical analysis of stress wave and gas pressure effects in bench blasting, *Ph.D. Thesis*, University of Maryland.
- Yu, T. R. and Vongpaisal. S. (1996). New blast damage criteria for underground blasting, *CIM Bulletin*, No. 998, Vol. 89, pp. 139-145.



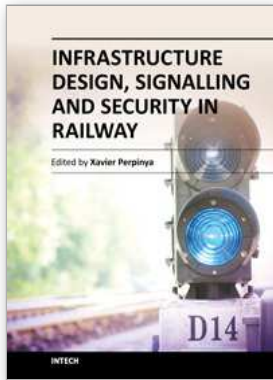

## **Infrastructure Design, Signalling and Security in Railway**

Edited by Dr. Xavier Perpinya

ISBN 978-953-51-0448-3

Hard cover, 522 pages

**Publisher** InTech

**Published online** 04, April, 2012

**Published in print edition** April, 2012

Railway transportation has become one of the main technological advances of our society. Since the first railway used to carry coal from a mine in Shropshire (England, 1600), a lot of efforts have been made to improve this transportation concept. One of its milestones was the invention and development of the steam locomotive, but commercial rail travels became practical two hundred years later. From these first attempts, railway infrastructures, signalling and security have evolved and become more complex than those performed in its earlier stages. This book will provide readers a comprehensive technical guide, covering these topics and presenting a brief overview of selected railway systems in the world. The objective of the book is to serve as a valuable reference for students, educators, scientists, faculty members, researchers, and engineers.

### **How to reference**

In order to correctly reference this scholarly work, feel free to copy and paste the following:

More Ramulu (2012). Special Tunnel Blasting Techniques for Railway Projects, Infrastructure Design, Signalling and Security in Railway, Dr. Xavier Perpinya (Ed.), ISBN: 978-953-51-0448-3, InTech, Available from: <http://www.intechopen.com/books/infrastructure-design-signalling-and-security-in-railway/special-tunnel-blasting-techniques-for-railway-projects->

**INTECH**  
open science | open minds

### **InTech Europe**

University Campus STeP Ri  
Slavka Krautzeka 83/A  
51000 Rijeka, Croatia  
Phone: +385 (51) 770 447  
Fax: +385 (51) 686 166  
[www.intechopen.com](http://www.intechopen.com)

### **InTech China**

Unit 405, Office Block, Hotel Equatorial Shanghai  
No.65, Yan An Road (West), Shanghai, 200040, China  
中国上海市延安西路65号上海国际贵都大饭店办公楼405单元  
Phone: +86-21-62489820  
Fax: +86-21-62489821

© 2012 The Author(s). Licensee IntechOpen. This is an open access article distributed under the terms of the [Creative Commons Attribution 3.0 License](#), which permits unrestricted use, distribution, and reproduction in any medium, provided the original work is properly cited.