

## Excel 500–XCL5010 CONTROL SYSTEM

### HONEYWELL EXCEL 5000 OPEN SYSTEM

#### SPECIFICATION DATA



### GENERAL

The Excel 500 is a freely programmable control and monitoring system designed specifically for building management. Using the latest Direct Digital Control (DDC) technology, the Excel 500's modular design is particularly well-suited for use in medium-sized buildings (e.g. schools, hotels, offices, shopping centers, and hospitals). With its LONWORKS® network interface, the Excel 500 is LONMARK™ compliant and offers a whole range of interoperability options.

In addition to control applications for heating, ventilation, and air conditioning (HVAC), the Excel 500 also performs a wide range of energy management functions, including optimum start/stop, night purge, and maximum load demand. Up to four Building Supervisors can be connected via the system bus. A modem or ISDN terminal adapter can be connected directly to the XCL5010 for communication with a data transmission rate of up to 38.4 Kbaud via the public telephone network.

The modular design enables the system to be expanded to meet growing needs. The data point user addresses and plain language descriptors are stored in the controller and are therefore available for viewing locally at an external interface without the need of a central PC.

The Excel 500 is suitable for use in open LONWORKS networks. Thus, in addition to its own I/O modules (see Table 1), an Excel 500 can operate on the same LONWORKS bus as other Excel 500 controllers (each with its own I/O modules), Excel 10 and Excel 50 controllers, and other Honeywell and third-party LONWORKS devices.

### FEATURES

- **Various state-of-the-art communication options:** C-bus (between up to 30 Excel 500 controllers) or Open LONWORKS® bus communication; modem or ISDN terminal adapter at up to 38.4 Kbaud
- **Unique features in open LONWORKS networks:** NV-Booster® reduces the number of required NVs and thus also the number of required controllers; NV bindings can be restored after controller reset (and thus need not be redone after exchanging controllers); 512 NVs supported for LONWORKS integration; autobinding of Honeywell I/O modules makes NV binding unnecessary, thus saving considerable engineering effort
- Typically, **190** physical inputs/outputs can be controlled via network variables in a LONWORKS network
- **128** physical data points, **256** pseudo data points, and up to **16** Distributed I/O modules per Excel 500 controller (C-bus communication)
- DIN-rail mounting (e.g. in control cabinet)
- Applications programmable with Honeywell's CARE programming tool and downloadable into Flash EPROM
- **Enhanced controller functions including:** alarm, trend and global broadcast hysteresis, network-wide time synchronization, firmware downloading via modem and C-bus
- Internal power supply module
- Shared transformer (CPU and Distributed I/O modules connected to the same transformer)
- Optimum access to terminals

**NOTE:** The XCL5010 has no internal display; thus, an XI582 operator interface or PC-based XL-Online operator and service software is needed when interfacing.

**Table 1. Modules for the Excel 500 (XCL5010) System**

modules	description
XCL5010	Computer module Excel 500 (supports Distributed and Smart I/O), incl. power supply and communication; UL916-approved
XFL521/B	Analog input module
XFL522A/B	Analog output module
XFL523/B	Digital input module
XFL524A/B	Digital output module
XFCxxxxxx	Smart I/O modules

**NOTE:** See also Distributed I/O Specification Data (EN0B-0090GE51) and Smart I/O Product Data (EN0B-0311GE51) for more information.

## DESCRIPTION

The Excel 500 System is part of Honeywell's EXCEL 5000® family of controllers. The Excel 500 is freely programmable and can be used as a stand-alone controller or as part of a network. The Excel 500 System provides energy management and control functions via LONWORKS bus to Honeywell LonWorks® I/O modules, 3<sup>rd</sup>-party LonWorks® I/O modules, or 3<sup>rd</sup>-party LonWorks® devices.

**NOTE:** The XCL5010 CPU can use only external I/O modules. There is no possibility of connecting internal plug-in I/O modules.

The Excel 500 can communicate with any LONWORKS product. Up to 512 LONWORKS network variables can be mapped to internal data points.

There are three sources for Excel 500 program applications:

1. Standard HVAC technology applications can be assembled as needed using Honeywell's Windows-based CARE programming tool.
2. Excel 500 application programs can be freely programmed using CARE. The user program is then automatically generated based on the graphically designed schematic diagram, instrumentation, and control strategies.
3. A set of predefined applications (MODAL) is available in order to provide state-of-the-art applications without the need of programming.

## SPECIFICATIONS

### Electrical

#### Operating voltage

24 Vac, ± 20%, 21...30 Vdc

#### Power consumption

Max. 5 VA (max. 4 W)

#### Memory buffer

In case of power failure, the super gold capacitor saves RAM content and real-time clock for 72 hours (environmentally friendly; no problems disposing of dead batteries).

#### Overvoltage protection

All inputs and outputs are protected against 24 Vac and 40 Vdc overvoltage as well as short-circuiting. Terminal 2 of the screw terminal block is protected by a quick-acting 4-A fuse behind the terminal block.

### Environmental

#### Ambient temperature

Operation: 32...122 °F (0...50 °C)  
Storage: -4...+158 °F (-20...+70 °C)

#### Ambient humidity (operation and storage)

5 to 93% r.h. non-condensing

### Mechanical

#### Housing dimensions (H x W x D)

5.90 x 7.79 x 3.82 in. (150 x 198 x 97 mm)

#### Housing material

Plastic, flame-retardant

#### Mounting methods

DIN-rail mounting (e.g. in control cabinet)

#### Calculated lifetime of weakest components

MTBF ≥ 13.7 years

#### Protection class

IP 30

### Memory

- 64 KB EPROM (boot)
- 256 KB RAM
- 1 MB Flash EPROM (firmware and application)
- 4 K bit EEPROM

### Communication

#### C-Bus

The C-bus transmits data between the EXCEL 5000® System controllers, gateways to 3<sup>rd</sup>-party systems, and building supervisors at 9.6 Kbaud up to 76.8 Kbaud. The max. C-bus network length is 1,200 m (3,900 ft.). A switch is provided for selectable termination. There is a max. of 30 controllers or devices per C-bus. See Excel 500/600 Installation Instructions (EN1R-1047GE51) for wiring details.

#### LONWORKS Bus

The Excel 500 uses an FTT-10A Free Topology Transceiver, transmitting data at 78 Kbaud using LonTalk® protocol. Cable length from 1,050 to 7,200 ft. (320 to 2,200 m). See Excel 500/600 Installation Instructions (EN1R-1047GE51) for wiring details.

#### External Interface / Modem

A 9-pin Sub-D connector, RS232, is provided as a serial port to connect an external interface (e.g. the XI582 operator interface or the PC-based XL-Online operator and service software) or a modem or ISDN terminal adapter for dial-up access at a transmission rate of up to 38.4 Kbaud.

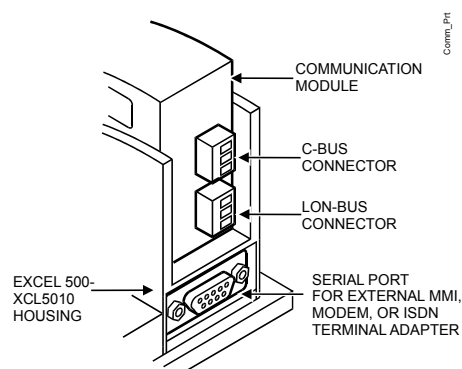

Fig. 1. External interfaces

### Application Module XDL505

#### Housing

Plug-in plastic module.

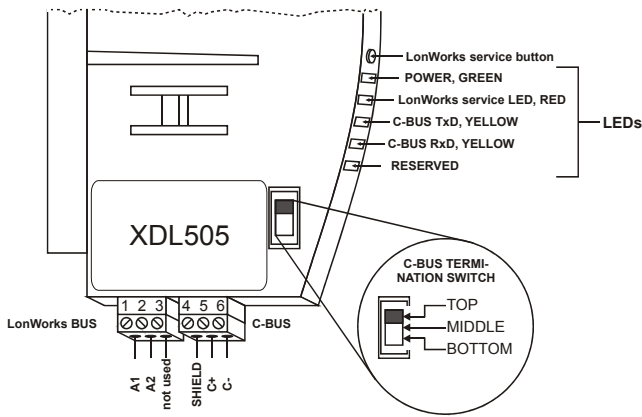

Fig. 2. XDL505 Application module LEDs and ports

### Terminal Block

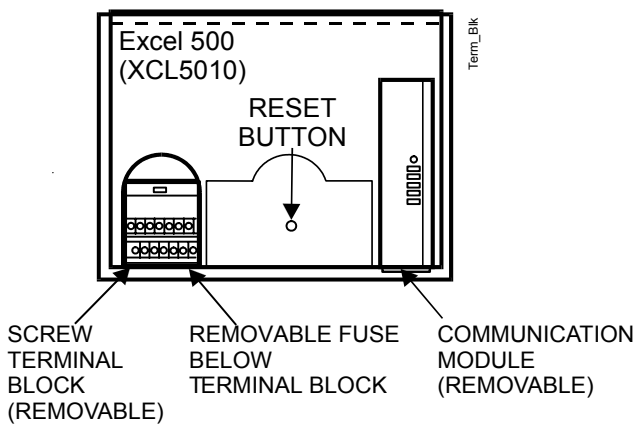

Fig. 3. Rear view of housing

### Assignment Terminal Block

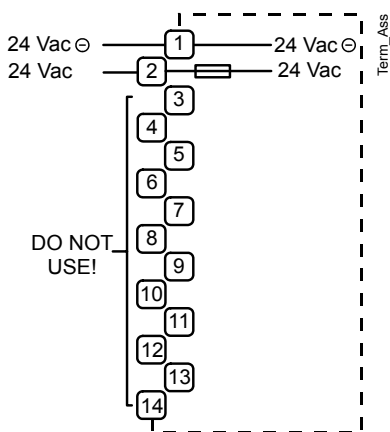

Fig. 4. Terminal block assignment

### EXTERNAL I/O MODULES

See the Specification Data sheets for Distributed I/O (EN0B-0090GE51) and Smart I/O (EN0B-0311GE51).

## OPERATOR INTERFACE XI582



Fig. 5. The XI582 Operator Interface

The XI582 operator interface is the command and information center of the Excel 500 system. With it, data can be entered and displayed. Information such as current temperature values, control status, etc. can also be displayed. The menu-driven, 6-line, backlit LCD graphic display with 34 characters per line, together with eight clearly marked keys, makes the device easy to use.

The operator interface is connected to the serial port next to the communication module. The XI582 can be mounted up to 48 ft. (15 m) away from the controller. This can be extended to 328 ft. (100 m) using line drivers.

### XL-ONLINE

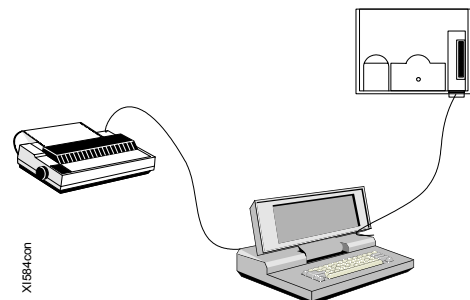

Fig. 6. Excel 500 (XCL5010) with XL-Online and printer

The PC-based XL-Online is the local intelligent operating and service software. It performs all the operating functions of the XI581/XI582 as well as having the advantages of a PC. Not only can the XL-Online make major modifications such as changing setpoint values and time program switching points, it also offers all service and commissioning functions.

The XL-Online can be operated at five different access levels, three of which are password-protected. A printer can be connected to the parallel interface of the XL-Online to log alarms and error messages. As with the XI582, the PC with the XL-Online operator and service software can be placed up to 15 meters from the computer module. Line drivers allow distances of up to 328 ft. (100 m).

## PROGRAMMING

The Excel 500 system includes a comprehensive software package specially designed to meet the requirements of application engineers. The easy to use, menu-driven software features the following functions:

- data point description,
- time program,
- alarm handling,
- application program (DDC program),
- password protection.

### Data Point Description

Data points are the basis of the Excel 500 system. They contain system-specific information such as values, status, limit values, and default settings. The user has easy access to data points and the information that they contain. The user can recall and modify information in the data points. In the case of LONWORKS applications, up to 512 NVs can be created.

### Time Program

The time program can be used to enter the setpoint or status at any time for any data point. The following time programs are available:

- daily program,
- weekly program,
- annual program,
- TODAY function,
- special day list.

Daily programs are used to create a weekly program. The annual program is created automatically by multiplying the weekly program and then incorporating daily programs. The TODAY function allows direct changes to the switching program. It allows you to allocate a setpoint or status to the selected data point for a defined period of time.

### Alarm Handling

The alarm handling facility offers system security. Alarm signals can, for example, alert the operator to scheduled maintenance work. All alarms that occur are stored in data files and reported immediately. If your system configuration allows, you can also list alarms on a printer or transmit alarms to higher-level devices via the local bus or a modem.

There are two types of alarms, critical and non-critical. Critical alarms (e.g. system alarms caused by a fault in the controller) have priority over non-critical alarms. To distinguish between alarm types, you can generate your own alarm messages or use pre-programmed system messages. The following events all generate alarm messages:

- exceeding limit values,
- overdue maintenance work,
- totalizer readings,
- digital data point changes of state.

### Application Program (DDC program)

You can use the Honeywell CARE (Computer Aided Regulation Engineering) programming tool to create application programs for your system. A particular advantage offered by CARE is the ability to create a fully functional control program without needing to be familiar with the programming language. A set of predefined applications (MODAL) is available in order to provide state-of-the-art applications without the need of programming.

### Password Protection

The control system is also protected by passwords. This ensures that only authorized persons have access to system data. There are four operator levels, each protected by its own password.

**Operator level 1:** Read only. The operator can display information about setpoints, switching points, and operating hours.

**Operator level 2:** Read and make limited changes. The operator can display system information and modify certain pre-set values.

**Operator level 3:** Read and make changes. System information can be displayed and modified.

**Operator level 4:** Programming can be carried out.

### Trending

The Excel 500 system provides controller-based trending. This feature allows historical values to be stored in the controller. Both time-based or value-hysteresis-based trending are possible.

## ACCESSORIES

Table 2 lists the accessories which are available for the Excel 500 (XCL5010).

**Table 2. Accessories for the Excel 500 (XCL5010)**

order code	description
XI582	operator interface
XW582	cable to XI582AH, 15 ft. (5 m)
XW585	cable to XL-Online, 15 ft. (5 m)
XL50-ACC2	Pair of DIN-rail mounting clips <b>NOTE:</b> One pair of DIN-rail mounting clips is included in each Excel 500 package

# Dimensions

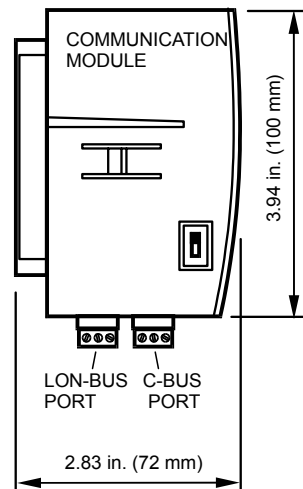
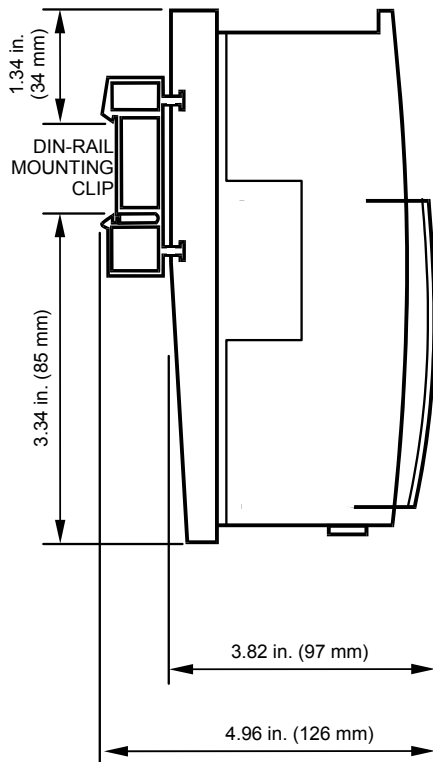
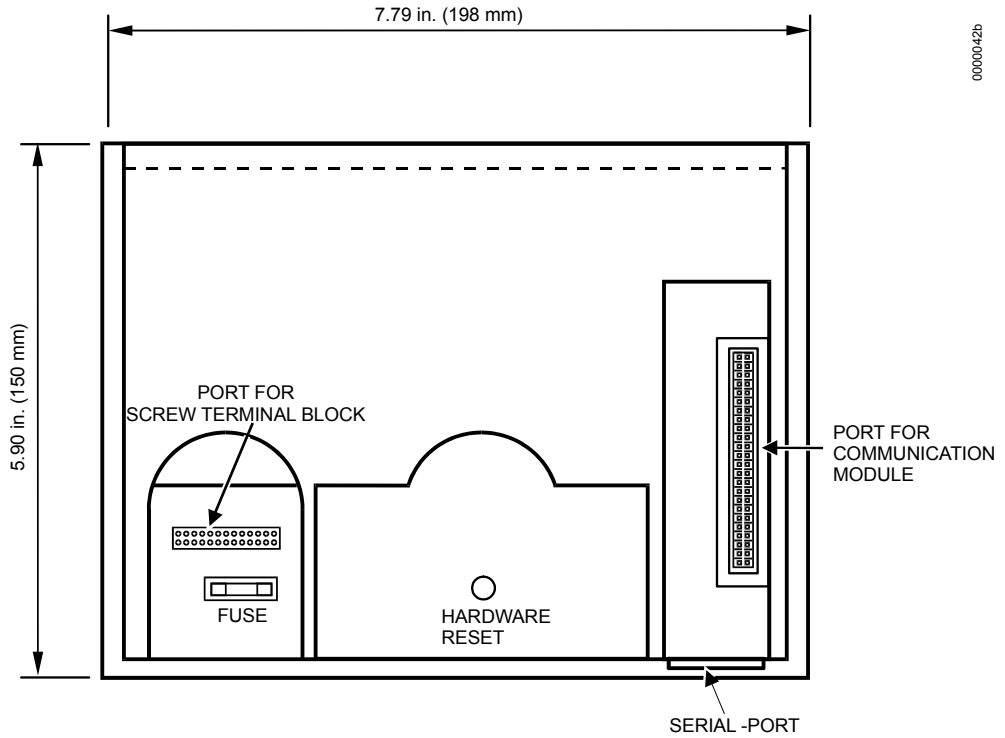

**Honeywell**

---

Manufactured for and on behalf of the Environmental and Combustion Controls Division of Honeywell Technologies Sàrl, Ecublens, Route du Bois 37, Switzerland by its Authorized Representative:

**Automation and Control Solutions**

**Honeywell GmbH**

Böblinger Straße 17

D-71101 Schönaich

Phone: (49) 7031 63701

Fax: (49) 7031 637493

<http://ecc.emea.honeywell.com>

Subject to change without notice. Printed in Germany

ENOB-0203GE51 R0308