

**SPECIFICATION
FOR
15kV and 38kV SUBSTATION TYPE POWER CIRCUIT BREAKERS
NO. 547-653-ES001**

**TERREBONNE PARISH CONSOLIDATED GOVERNMENT
CITY OF HOUMA, LA**



<u>REV. NO.</u>	<u>DESCRIPTION</u>	<u>DATE</u>	<u>APPROVAL</u>
0	Issued for Bid	01/28/19	DTD/JJB

**J. J. BERGERON & COMPANY, INC.
METAIRIE, LOUISIANA**

**SPECIFICATION
FOR
15kV and 38kV SUBSTATION TYPE POWER CIRCUIT BREAKERS**

THIS PAGE IS A RECORD OF ALL DOCUMENTATION REVISIONS. ONLY THE NEW OR REVISED PAGES ARE NORMALLY ISSUED EACH TIME THE DOCUMENT IS CHANGED.

THE NATURE OF THE REVISION IS NOTED UNDER REMARKS, BUT THESE REMARKS ARE NOT A PART OF THE DOCUMENT. THE REVISED PAGES BECOME PART OF THE ORIGINAL DOCUMENT AND SHALL BE COMPLIED WITH IN THEIR ENTIRETY.

REV	DATE	BY	CKD	APP	PAGES	REMARKS		
A	11/19/18	DTD	JJB	JJB	ALL	FOR REVIEW		
B	12/18/18	DTD	JJB	JJB	ALL	FOR REVIEW		
C	12/19/18	DTD	JJB	JJB	9-23	FOR REVIEW BY TERREBONNE		
0	01/28/19	DTD	JJB	JJB	10-25	ISSUED FOR BID		
J. J. Bergeron & Company, Inc.					Terrebonne Parish Consolidated Government Houma, Louisiana		Specification No. 547-653-ES001 Client No. 547 Job No. 653	Revision 0

**SPECIFICATION
FOR
15kV and 38kV SUBSTATION TYPE POWER CIRCUIT BREAKERS**

TABLE OF CONTENTS

1.0	SCOPE	
2.0	STANDARDS AND CODES	
3.0	GENERAL REQUIREMENTS	
4.0	DESIGN REQUIREMENTS	
5.0	DETAIL REQUIREMENTS	
6.0	INSPECTION AND TESTING	
7.0	SHIPPING REQUIREMENTS	
8.0	ATTACHMENTS	
	8.1 Data Sheets	
		547-653-ES001-1
		547-653-ES001-2
		547-653-ES001-3
		547-653-ES001-4
	8.2 Schedule of Drawing and Other Document Requirements	
	8.3 Applicable Drawings	
		547-653-BD1
		547-653-BD2
		547-653-BD3
		547-653-BD4

1.0 SCOPE

- 1.1 This specification covers the supply and delivery of various, three phase, outdoor, dead tank, free standing, power circuit breakers, rated 15.0 kV and 38.0 kV, which utilize vacuum as the interrupting medium. Associated current transformers are also included. These circuit breakers will be used in outdoor electric distribution substations and shall be properly designed and constructed for such service.
- 1.2 Specific requirements are provided in the attached Data Sheets and “Schedule of Drawings and Other Document Requirements”.
- 1.3 The Supplier shall furnish all labor, materials, and equipment necessary to fabricate, construct, assemble, test, paint, and ship power circuit breakers and associated equipment.

2.0 STANDARDS AND CODES

- 2.1 All circuit breakers shall be designed, manufactured, and tested in accordance with ANSI/IEEE C-37 and applicable parts/sections of the latest revisions of the following standards and codes:

ANSI/IEEE C37.04 and .06 - Standard ratings and preferred ratings for Outdoor AC Medium-Voltage Circuit Breakers.

ANSI/IEEE C37.11 - Requirements for electrical control for AC High-Voltage Circuit Breakers rated on a symmetrical current basis or a total current basis.

ANSI/IEEE C37.09 - Standard Design and Production Testing

ANSI Z55.1 - Gray Finishes for Industrial Apparatus and Equipment.

ANSI/IEEE C57.13 - Requirements for Instrument Transformers.

NEMA SG4 - Alternating Current High Voltage Circuit Breakers.

NEC - National Electric Code

NEMA - National Electrical Manufacturers Association

NESC - National Electrical Safety Code

OSHA - Occupational Safety and Health Administration

- 2.2 It shall be the Supplier’s responsibility to be knowledgeable of the requirements of these standards and codes. Any changes or alterations to the equipment to make it meet these standards and codes shall be at the expense of the Supplier. When two standards differ, the stricter shall apply.

3.0 GENERAL REQUIREMENTS

- 3.1 Each bidder shall submit, with each copy of the proposal, specifications and general drawings describing and illustrating the equipment offered including shop drawings indicating outline dimensions, enclosure construction, lifting and supporting points, electrical single line diagram, and equipment electrical ratings.
- 3.2 Complete manufacturing and delivery schedules (depicting weeks after order) including approval drawing submittals, fabrication, production testing, and shipment of the circuit breakers shall be submitted along with the proposal.
- 3.3 The Supplier shall provide approval drawings, corrected “certified for manufacture drawings”, instruction books and test reports as requested in “Schedule of Drawings and Other Document Requirements”. Any Supplier corrections to this schedule shall be described in the proposal. Submittal and review/approval drawings may be submitted in pdf format. Final drawings and instruction books shall be submitted in both pdf and hard copy formats. All drawing and other document requirements outlined in this schedule shall be sent to:
- Terrebonne Parish – Project 547-653-ES001
c/o Mr. Tommy J. LeCompte
301 Plant Road
Houma, Louisiana 70363
- 3.5 A list of special tools and equipment required for installation and maintenance as well as a list of recommended spare parts with pricing shall be submitted with the proposal.
- 3.6 The Supplier shall quote an all-inclusive daily rate cost for providing a field serviceman for commissioning of any / all of the circuit breakers. Any commissioning support would be an optional, separate purchase by Terrebonne.
- 3.7 The Supplier shall warrant the breaker and associated equipment for a period of not less than one year from the date of energization or 18 months from the date of shipment, whichever ever comes first. Any defect in the design, materials, or workmanship discovered within this period shall be repaired or replaced without cost to Terrebonne Parish Consolidated Government, including shipping costs.
- 3.8 Manufacturing Facility shall have specific experience in the manufacture of medium voltage substation vacuum outdoor breakers and have at least five years documented experience.

4.0 DESIGN REQUIREMENTS

- 4.1 All breakers will be rated and tested on a symmetrical current basis in accordance with ANSI/IEEE C37, latest revision.
- 4.2 Breakers shall be electrically operated, electrically and mechanically trip-free. Each breaker shall be supplied with control switches, operations counter, open/closed position indicator, red/green indicating lights, auxiliary switches, and closing and tripping mechanism.
- 4.3 Breaker shall operate by means of a stored energy mechanism with electrically controlled closing and trip.
- 4.4 Unless otherwise specified, the breaker color shall be ANSI No. 70 light gray finish and all bushings shall be ANSI No. 70 light gray.
- 4.5 Breaker shall be equipped with “anti-pump” close circuit.
- 4.6 All circuit breakers shall have a grounded tank design, dead-tank.
- 4.7 The operating mechanism shall be equipped with an externally visible mechanical breaker position indicator marked “Closed” and “Open”. The color associated with Close shall be red, and the color associated with Open shall be green.
- 4.8 The breaker shall be rated for an ambient temperature range of –25 degrees to +40 degrees Celsius.
- 4.9 The breaker shall be rated for Seismic Zone 4 as described by ANSI/IEEE 693-1984.
- 4.10 The breaker shall be rated to withstand a wind load of 140 mph imposed upon the structure supporting the terminal connection.
- 4.11 The breaker shall be rated for use at altitudes up to 3300 ft. above sea level per ANSI C37.04 Section 4.2.2.

5.0 DETAIL REQUIREMENTS

- 5.1 Breaker accessory equipment shall include, but not limit to, the following:
 - Rigid control cabinet with gasketed, hinged doors; rain shield; pad lockable latch, and removable bottom plate for conduit entry
 - Hand closing lever and a manual charging device for stored energy mechanism
 - NEMA 4 hole, flow tin plated terminal pads on breaker bushings.
 - An emergency manual trip, ANSI Device Number 69, shall be provided and shall be readily accessible on the exterior mechanism side of the breaker. It shall be labeled “MANUAL TRIP OPEN” and the actuating

handle shall be painted red. The device shall be operable from the exterior of the breaker without the necessity of opening any doors, panels, etc. Actuation of the device will block any electrical closing of the breaker until the switch has been manually reset.

5.2 Control and Wiring

- 5.2.1 All control wiring shall be stranded copper wire with a minimum size of # 14 AWG Type SIS for general control and #10 AWG Type SIS for CT circuits. Control wires shall be terminated on 12 point, barrier type terminal blocks, rated 600 Volts, 30 amps, with marking strips using pre-insulated ring type solderless compression terminals. Control wiring shall be brought to terminal blocks in a manner equivalent to the drawings in section 8.3. Wire color shall be gray.
- 5.2.2 Each breaker shall have a minimum of 12 spare auxiliary contacts comprising 6 “a” contacts and 6 “b” contacts for customer use. All spare auxiliary contacts shall be wired to terminal blocks.
- 5.2.3 Control cabinet shall have a thermostatically controlled, guarded space heater rated as specified in the Data Sheets. The heater shall be of sufficient size to prevent moisture accumulation.
 - 5.2.3.1 Heaters should be located away from cabinet doors.
 - 5.2.3.2 A Heater guard shall be provided over all heaters to prevent direct contact by personnel.
- 5.2.4 A 120 VAC, 15A convenience outlet shall be furnished in the control cabinet.
- 5.2.5 Alarm points shall be wired out through a test switch to terminal blocks. Alarm contacts shall be suitable for operating at DC voltages specified in the Data Sheets.
- 5.2.6 One pistol grip control switch, Electroswitch Series 24, engraved TRIP-CLOSE shall be supplied.
- 5.2.7 Furnish separate molded case circuit breakers for the following circuits:
 - 5.2.7.1 Single phase voltage heaters
 - 5.2.7.2 Control (Close) circuit
 - 5.2.7.3 Control (Trip) circuit
 - 5.2.7.4 Spring Charging Motor
 - 5.2.7.5 Single phase 115 VAC receptacle and control cabinet light.
- 5.2.8 All circuit breakers are to have necessary control wiring brought out to terminal blocks for external control connections per applicable drawings in section 8.3.

Specification 547-653-ES001 for 15 and 38 kV Power Circuit Breakers

- 5.2.9 Each circuit breaker, mechanism, and current transformer shall be provided with stainless steel engraved/enameled nameplates with minimum information as noted in ANSI C37.04. Each nameplate shall be in English with all symbols in accordance with ANSI standards. The breaker nameplate shall have a three-line diagram of breaker and bushing markings. Current transformer nameplate shall also include the thermal rating factor.
 - 5.2.10 At least one spare 12-point terminal block shall be provided for customer use.
 - 5.2.11 An interior light and door-operated disconnect switch rated for 120 VAC shall be provided for the control cabinet enclosure.
 - 5.2.12 All current transformer (CT) leads shall be brought out to current shorting type terminal blocks in the control cabinet which are clearly marked to indicate CT, lead number, and bushing number.
 - 5.2.13 Each breaker shall have a trip coil monitoring scheme.
 - 5.2.14 The breaker schematics/ wiring diagrams shall be compatible with all attached drawings in section 8.3.
- 5.3 Interrupter
- 5.3.1 The vacuum interrupters shall be hermetically sealed in high vacuum, protecting contacts from moisture and contaminated atmosphere.
 - 5.3.2 The interrupters shall be maintenance free.
 - 5.3.3 Circuit breaker shall have readily accessible provisions for measuring the contact wear for each pole.
- 5.4 Operating Mechanism
- 5.4.1 The mechanism shall be spring-charged stored-energy with electrical charging motor.
 - 5.4.2 The mechanism and control circuits shall be located in the low voltage compartment. The mechanism shall not be mounted in a separate housing.
 - 5.4.3 The mechanism shall be designed with an integral, manual charging handle. Charging handle shall not be removable.
 - 5.4.4 The following shall be clearly visible on the mechanism when the outer door is closed:
 - 5.4.4.1 A non-resettable, mechanical 5-digit operation counter which increases on each trip operation.
 - 5.4.4.2 A mechanical indicator to indicate the open and closed positions of the circuit breaker.

Specification 547-653-ES001 for 15 and 38 kV Power Circuit Breakers

5.4.4.3 A mechanical indicator to indicate the status of the closing springs.

5.4.5 The mechanism shall be designed with a latch-check switch as standard.

5.5 Bushings

5.5.1 Six (6) roof bushings shall be provided. The material shall be porcelain and ANSI # 70 light gray in color.

5.5.2 Bushing terminals shall be threaded stud type and capable of accepting a 4-hole NEMA stud to flat connectors (Type HDSF or equal).

5.6 Mechanical Construction

5.6.1 The enclosure shall be weatherproof and designed in a modular construction isolating line potential components from secondary control devices.

5.6.2 The high voltage compartment shall house the vacuum interrupter assemblies supported on standoff insulators.

5.6.3 The enclosure shall be provided with lifting eyes for lifting the entire unit during loading and unloading.

5.6.4 The breaker shall be shipped completely assembled. Breakers shall not be shipped with legs unattached.

5.6.5 Ground pads, 2"x 3.5" with provisions for NEMA 2-hole connectors, shall be welded on each side of the enclosure for external ground connections. Ground cables from the roof and HV & LV compartments shall be connected internally to the ground pads to insure a solidly grounded enclosure, with negligible difference in ground potential between compartments. Enclosure grounding shall not depend on bolted connections or "star washers".

5.6.6 The breaker legs shall have an adjustable height range of at least 24" in 2"- 4" increments.

5.6.7 Outer doors shall have padlockable handles for preventing access to all controls in the enclosure. Doors are to be vertically hinged. Provisions for holding all doors in the open position 180 degrees shall also be provided. It shall be documented that the breaker passed rain testing per ANSI C37.20.2, Section 5.2.9.

5.6.8 The low voltage cabinet bottom shall have a removable cover for entrance of user's control conduit. Conduit entry location to be clearly marked on detail drawings.

6.0 INSPECTION AND TESTING

- 6.1 Owner and /or their representative shall have free access to all manufacturing facilities for inspection during manufacture and testing and may copy any or all test data. Such inspection shall in no way lessen any responsibilities of the manufacturer.
- 6.2 Breaker shall be design tested to ANSI and ANSI/IEEE standards.
- 6.3 The breaker shall receive and pass all production tests per ANSI C37, latest revision.

7.0 SHIPPING REQUIREMENTS

- 7.1 Owner requires Circuit Breaker shipment to be divided into two (2) lots separated by a period of 120 days. The first shipment shall contain the following circuit breakers:

- 7.1.1.1 B0801 & B0802

- 7.1.1.2 Gen. #16 & B5B03

- 7.1.1.3 B1201, B1202, B1203, B1204

- 7.1.2 The second shipment shall contain the following circuit breakers:

- 7.1.2.1 B0902 & B0903

- 7.1.2.2 HB0904, HB1003

- 7.1.2.3 B1101, B0501, B0502, B0104, B0105, SWFD1

- 7.2 Each breaker shipment and all accessories associated with that particular shipment shall be shipped TOGETHER to Owner's destination. The manufacturer is responsible for all equipment until it is received at the Owner's destination (FOB Destination).
- 7.3 All crates and packages shall be numbered and identified with purchased order number and individual breaker location mark number. Breaker and accessories shall be packed to adequately provide protection against any damage that may occur during shipment and be suitable for outdoor storage at the job site for 6 months.
- 7.4 The Manufacturer must contact the Owner's representative, Tommy J. LeCompte at (985) 232-2828, at least 48 hours prior to shipment. The Breaker and all associated equipment shall be shipped to:

- Terrebonne Parish Consolidated Government
c/o Mr. Tommy J. LeCompte
301 Plant Road
Houma, Louisiana 70363

8.0 ATTACHMENTS

8.1 Data Sheet

547-653-ES001-1
547-653-ES001-2
547-653-ES001-3
547-653-ES001-4
547-653-ES001-5

8.2 Schedule of Drawing and Other Document Requirements.

8.3 Applicable Drawings

547-653-BD1	TPCG 15 kV 1200A Breakers B0801-B0802 Outdoor Vacuum Circuit Breakers Typical 120VAC & 125VDC Schematic Diagrams
547-653-BD2	TPCG 15 kV 1200A Breakers B1201-B1204, B1101, B0104-B0105 Outdoor Vacuum Circuit Breakers Typical 120VAC & 48VDC Schematic Diagrams
547-653-BD3	TPCG 15 kV 1200A Breakers B0902, B0903, B0501-B0502, SWFD1 Outdoor Vacuum Circuit Breakers Typical 120/240VAC & 48VDC Schematic Diagrams
547-653-BD4	TPCG 38 kV 1200A Breakers HB0904 & HB1003 Outdoor Vacuum Circuit Breakers Typical 120/240VAC & 48VDC Schematic Diagrams
547-653-BD5	TPCG 38 kV 2000A Breakers Gen #16, and B5B03 Outdoor Vacuum Circuit Breakers Typical 120/208VAC & 125VDC Schematic Diagrams

**POWER
CIRCUIT BREAKERS
DATA SHEET**

SHEET 1 OF 2
DATE SHEET NO.:
547-653-ES001-1

CLIENT: Terrebonne Parish Consolidated Government (TPCG)
PROJECT: Substation Breaker Replacements
JOB NO.: 547-653

NO.	BY	DATE	REVISION	SPEC. NO.
1	DTD	01/21/19	0	547-653-ES001
				REV. 0
				DATE 01/21/19
				P.O. NO.
				BY DTD
				CHKD JJB
				APPR. JJB

1.0 RATINGS

- 1.1 NUMBER OF UNITS: 2
- 1.2 TAG NUMBERS (LOCATION): B0801, B0802
- 1.3 NOMINAL OPERATING VOLTAGE (LINE-LINE): 13.8 KV
- 1.4 MAXIMUM OPERATING VOLTAGE (LINE-LINE): 15.5 KV
- 1.5 VOLTAGE RANGE FACTOR: 1.0
- 1.6 INSULATION WITHSTAND TEST VOLTAGE, kV Crest: 110 KV
- 1.7 CONTINUOUS CURRENT: 1200 AMPERES
- 1.8 MAX. SYMMETRICAL INTERRUPTING CURRENT: 25 KA
- 1.9 FREQUENCY: 60 Hertz
- 1.10 RATED MINIMUM INTERRUPTING TIME: 3 cycles
- 1.11 DUTY CYCLE: OCO-15 sec.-CO
- 1.12 CURRENT TRANSFORMERS:
 - [X] RELAY Qty: 1 per bushing Accuracy C200 Bushings 1,2,3,4,5,6
 - Ratio: 1200-5 Amperes [X] Multi-Ratio [] Single Ratio
 - [] METERING Qty: _____ per bushing Accuracy _____
 - Ratio: _____ Amperes [] Multi-Ratio [] Single Ratio
- 1.13 SUPPLY VOLTAGE: 120/240 Volts AC single phase
- 1.14 CLOSE AND TRIPPING VOLTAGE: 125 Volts DC
- 1.15 SPRING CHARGING MOTOR: 120 Volts AC
- 1.16 HEATER VOLTAGE: 120 Volts AC
- 1.16 TRIP COILS: [] DUAL [X] SINGLE
- 1.17 BREAKER MONITOR POINTS (ALARM POINTS):
 - [X] Trip Coil Monitoring Scheme [X] Loss of Charging Motor Voltage
 - [X] Loss of Close Voltage [X] Loss of Heater AC Voltage
 - [X] Spring Discharge Alarm [X] Loss of Trip DC Voltage
- 1.18 ALARM CONTACT VOLTAGE: 125 Volts DC

2.0 CONSTRUCTION

- 2.1 LOCATION: [] Indoor [X] Outdoor
- 2.2 TYPE: [X] Dead Tank [] Live Tank
- 2.3 SEISMIC REQUIREMENT: ZONE 4
- 2.4 MAXIMUM HEIGHT (excluding bushing removal): 115 inches
- 2.5 INTERRUPTING MEDIUM: VACUUM
- 2.6 FINISH PAINT: [X] ANSI No. 70 Light gray [] Other
- 2.7 BUSHING: [X] PORCELAIN [] COMPOSITE
- 2.8 ACCESSORIES:
 - [X] Rigid control cabinet with gasketed, hinged doors, pad lockable latch, and removable bottom plate for conduit entry
 - [X] Hand closing lever and a manual charging device for stored energy mechanism
 - [X] NEMA 4 hole flow tin plated pads for breaker threaded stud type bushing (Type HDSF or Equal)
 - [X] NEMA 2 hole tin plated pads for grounding
 - [X] Guarded space heater and convenience outlet
 - [X] Control Switch [X] Control Cabinet Light [X] Indicating Lights [] Local/Remote Switch
- 2.8 PROTECTIVE RELAYS: [] YES [X] NO

2.9 DIMENSIONAL RESTRICTIONS:

Height (Excluding bushing removal) 9 feet – Adjustable Legs 8.5' to 11'

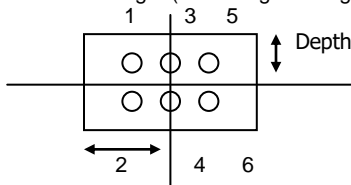

Width 7 feet Total
Depth 5 feet Total

CLIENT: Terrebonne Parish Consolidated Government (TPCG) PROJECT: Substation Breaker Replacements JOB NO.: 547-653	POWER CIRCUIT BREAKERS DATA SHEET				SHEET 2 OF 2		
					DATE SHEET NO.: 547-653-ES001-2		
	NO.	BY	DATE	REVISION	SPEC. NO. 547-653-ES001		
	1	DTD	01/21/19	0	REV. 0		
					DATE 01/21/19		
					P.O. NO.		
				BY DTD	CHKD	APPR. DTD	

3.0 DATA SUPPLIED BY MANUFACTURER WITH THE PROPOSAL

- 3.1 MANUFACTURER _____
- 3.2 PLACE OF MANUFACTURE _____
- 3.3 FULL WAVE BIL _____
- 3.4 RATED MAX VOLTAGE _____
- 3.5 RATED FREQUENCY _____
- 3.6 RATED CONTINUOUS CURRENT (A RMS) _____
- 3.7 INTERRUPTING CAPABILITY _____
- 3.8 INTERRUPT TIME (CYCLES) _____
- 3.9 CLOSING TIME (CYCLES) _____
- 3.10 CLOSE & LATCH (KA) _____
- 3.11 DUTY CYCLE _____
- 3.12 CLOSING DEVICE MAXIMUM CURRENT _____
- 3.13 TRIPPING DEVICE MAXIMUM CURRENT _____
- 3.14 NET WEIGHT (installed) _____
- 3.15 SHIPPING DATE (weeks ARO) _____
- 3.16 COMPLETE DIMENSIONS _____

4.0 NOTES

**POWER
CIRCUIT BREAKERS
DATA SHEET**

SHEET 1 OF 2

DATE SHEET NO.:
547-653-ES001-2

CLIENT: Terrebonne Parish Consolidated Government (TPCG)

PROJECT: Substation Breaker Replacements

JOB NO.: 547-653

NO.	BY	DATE	REVISION	SPEC. NO.
1	DTD	01/21/19	0	547-653-ES001
				REV. 0
				DATE 01/21/19
				P.O. NO.
				BY DTD
				CHKD
				APPR. DTD

1.0 RATINGS

- 1.1 NUMBER OF UNITS: 7
- 1.2 TAG NUMBERS (LOCATION): B1201, B1202, B1203, B1204, B1101, B0104, B0105
- 1.3 NOMINAL OPERATING VOLTAGE (LINE-LINE): 13.8 KV
- 1.4 MAXIMUM OPERATING VOLTAGE (LINE-LINE): 15.5 KV
- 1.5 VOLTAGE RANGE FACTOR: 1.0
- 1.6 INSULATION WITHSTAND TEST VOLTAGE, kV Crest: 110 KV
- 1.7 CONTINUOUS CURRENT: 1200 AMPERES
- 1.8 MAX. SYMMETRICAL INTERRUPTING CURRENT: 25 KA
- 1.9 FREQUENCY: 60 Hertz
- 1.10 RATED MINIMUM INTERRUPTING TIME: 3 cycles
- 1.11 DUTY CYCLE: OCO-15 sec.-CO
- 1.12 CURRENT TRANSFORMERS:
 - [X] RELAY Qty: 1 per bushing Accuracy C200 Bushings 1,2,3,4,5,6
 - Ratio: 1200-5 Amperes [X] Multi-Ratio [] Single Ratio
 - [] METERING Qty: _____ per bushing Accuracy _____
 - Ratio: _____ Amperes [] Multi-Ratio [] Single Ratio
- 1.13 SUPPLY VOLTAGE: 120/240 Volts AC single phase
- 1.14 CLOSE AND TRIPPING VOLTAGE: 48 Volts DC
- 1.15 SPRING CHARGING MOTOR: 120 Volts AC
- 1.16 HEATER VOLTAGE: 120 Volts AC
- 1.16 TRIP COILS: [] DUAL [X] SINGLE
- 1.17 BREAKER MONITOR POINTS (ALARM POINTS):
 - [X] Trip Coil Monitoring Scheme [X] Loss of Charging Motor Voltage
 - [X] Loss of Close Voltage [X] Loss of Heater AC Voltage
 - [X] Spring Discharge Alarm [X] Loss of Trip DC Voltage
- 1.18 ALARM CONTACT VOLTAGE: 48 Volts DC

2.0 CONSTRUCTION

- 2.1 LOCATION: [] Indoor [X] Outdoor
- 2.2 TYPE: [X] Dead Tank [] Live Tank
- 2.3 SEISMIC REQUIREMENT: ZONE 4
- 2.4 MAXIMUM HEIGHT (excluding bushing removal): 115 inches
- 2.5 INTERRUPTING MEDIUM: VACUUM
- 2.6 FINISH PAINT: [X] ANSI No. 70 Light gray [] Other
- 2.7 BUSHING: [X] PORCELAIN [] COMPOSITE
- 2.8 ACCESSORIES:
 - [X] Rigid control cabinet with gasketed, hinged doors, pad lockable latch, and removable bottom plate for conduit entry
 - [X] Hand closing lever and a manual charging device for stored energy mechanism
 - [X] NEMA 4 hole flow tin plated pads for breaker threaded stud type bushing (Type HDSF or Equal)
 - [X] NEMA 2 hole tin plated pads for grounding
 - [X] Guarded space heater and convenience outlet
 - [X] Control Switch [X] Control Cabinet Light [X] Indicating Lights [] Local/Remote Switch
- 2.8 PROTECTIVE RELAYS: [] YES [X] NO

2.9 DIMENSIONAL RESRICTIONS:

Height (Excluding bushing removal) 9 feet – Adjustable Legs 8.5' to 11'

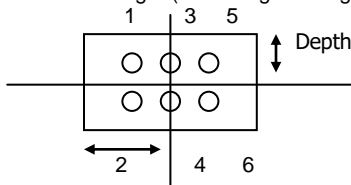

Width 7 feet Total
Depth 5 feet Total

CLIENT: Terrebonne Parish Consolidated Government (TPCG) PROJECT: Substation Breaker Replacements JOB NO.: 547-653	POWER CIRCUIT BREAKERS DATA SHEET				SHEET 2 OF 2		
					DATE SHEET NO.: 547-653-ES001-2		
	NO.	BY	DATE	REVISION	SPEC. NO. 547-653-ES001		
	1	DTD	11/23/18	0	REV. 0		
					DATE 11/23/18		
					P.O. NO.		
				BY DTD	CHKD	APPR. DTD	

3.0 DATA SUPPLIED BY MANUFACTURER WITH THE PROPOSAL

- 3.1 MANUFACTURER _____
- 3.2 PLACE OF MANUFACTURE _____
- 3.3 FULL WAVE BIL _____
- 3.4 RATED MAX VOLTAGE _____
- 3.5 RATED FREQUENCY _____
- 3.6 RATED CONTINUOUS CURRENT (A RMS) _____
- 3.7 INTERRUPTING CAPABILITY _____
- 3.8 INTERRUPT TIME (CYCLES) _____
- 3.9 CLOSING TIME (CYCLES) _____
- 3.10 CLOSE & LATCH (KA) _____
- 3.11 DUTY CYCLE _____
- 3.12 CLOSING DEVICE MAXIMUM CURRENT _____
- 3.13 TRIPPING DEVICE MAXIMUM CURRENT _____
- 3.14 NET WEIGHT (installed) _____
- 3.15 1ST SHIPPING DATE (weeks ARO) _____
- 3.16 2ND SHIPPING DATE (weeks ARO) _____
- 3.17 COMPLETE DIMENSIONS _____

4.0 NOTES

**POWER
CIRCUIT BREAKERS
DATA SHEET**

SHEET 1 OF 2
DATE SHEET NO.:
547-653-ES001-3

CLIENT: Terrebonne Parish Consolidated Government (TPCG)
PROJECT: Substation Breaker Replacements
JOB NO.: 547-653

NO.	BY	DATE	REVISION	SPEC. NO.	REV.	DATE	P.O. NO.	BY	CHKD	APPR.
1	DTD	01/21/19	0	547-653-ES001	0	01/21/19		DTD		DTD

1.0 RATINGS

- 1.1 NUMBER OF UNITS: 5
- 1.2 TAG NUMBERS (LOCATION): B0902, B0903, B0501, B0502, SWFD1
- 1.3 NOMINAL OPERATING VOLTAGE (LINE-LINE): 13.8 KV
- 1.4 MAXIMUM OPERATING VOLTAGE (LINE-LINE): 15.5 KV
- 1.5 VOLTAGE RANGE FACTOR: 1.0
- 1.6 INSULATION WITHSTAND TEST VOLTAGE, kV Crest: 110 KV
- 1.7 CONTINUOUS CURRENT: 1200 AMPERES
- 1.8 MAX. SYMMETRICAL INTERRUPTING CURRENT: 25 KA
- 1.9 FREQUENCY: 60 Hertz
- 1.10 RATED MINIMUM INTERRUPTING TIME: 3 cycles
- 1.11 DUTY CYCLE: OCO-15 sec.-CO
- 1.12 CURRENT TRANSFORMERS:
 - [X] RELAY Qty: 1 per bushing Accuracy C200 Bushings 1,2,3,4,5,6
 - Ratio: 1200-5 Amperes [X] Multi-Ratio [] Single Ratio
 - [] METERING Qty: _____ per bushing Accuracy _____
 - Ratio: _____ Amperes [] Multi-Ratio [] Single Ratio
- 1.13 SUPPLY VOLTAGE: 120/240 Volts AC single phase
- 1.14 CLOSE AND TRIPPING VOLTAGE: 48 Volts DC
- 1.15 SPRING CHARGING MOTOR: 240 Volts AC
- 1.16 HEATER VOLTAGE: 240 Volts AC
- 1.17 TRIP COILS: [] DUAL [X] SINGLE
- 1.18 BREAKER MONITOR POINTS (ALARM POINTS):
 - [X] Trip Coil Monitoring Scheme [X] Loss of Charging Motor Voltage
 - [X] Loss of Close Voltage [X] Loss of Heater AC Voltage
 - [X] Spring Discharge Alarm [X] Loss of Trip DC Voltage
- 1.19 ALARM CONTACT VOLTAGE: 48 Volts DC

2.0 CONSTRUCTION

- 2.1 LOCATION: [] Indoor [X] Outdoor
- 2.2 TYPE: [X] Dead Tank [] Live Tank
- 2.3 SEISMIC REQUIREMENT: ZONE 4
- 2.4 MAXIMUM HEIGHT (excluding bushing removal): 115 inches
- 2.5 INTERRUPTING MEDIUM: VACUUM
- 2.6 FINISH PAINT: [X] ANSI No. 70 Light gray [] Other
- 2.7 BUSHING: [X] PORCELAIN [] COMPOSITE
- 2.8 ACCESSORIES:
 - [X] Rigid control cabinet with gasketed, hinged doors, pad lockable latch, and removable bottom plate for conduit entry
 - [X] Hand closing lever and a manual charging device for stored energy mechanism
 - [X] NEMA 4 hole flow tin plated pads for breaker threaded stud type bushing (Type HDSF or Equal)
 - [X] NEMA 2 hole tin plated pads for grounding
 - [X] Guarded space heater and convenience outlet
 - [X] Control Switch [X] Control Cabinet Light [X] Indicating Lights [] Local/Remote Switch
- 2.8 PROTECTIVE RELAYS: [] YES [X] NO
- 2.9 DIMENSIONAL RESRICTIONS:
 - Height (Excluding bushing removal) 9 feet – Adjustable Legs 8.5' to 11'

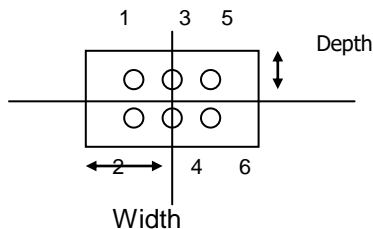

Width 7 feet Total
Depth 5 feet Total

CLIENT: Terrebonne Parish Consolidated Government (TPCG) PROJECT: Substation Breaker Replacements JOB NO.: 547-653	POWER CIRCUIT BREAKERS DATA SHEET				SHEET 2 OF 2		
					DATE SHEET NO.: 547-653-ES001-3		
	NO.	BY	DATE	REVISION	SPEC. NO. 547-653-ES001		
	1	DTD	01/21/19	0	REV. 0		
					DATE 01/21/19		
					P.O. NO.		
				BY DTD	CHKD	APPR. DTD	

3.0 DATA SUPPLIED BY MANUFACTURER WITH THE PROPOSAL

- 3.1 MANUFACTURER _____
- 3.2 PLACE OF MANUFACTURE _____
- 3.3 FULL WAVE BIL _____
- 3.4 RATED MAX VOLTAGE _____
- 3.5 RATED FREQUENCY _____
- 3.6 RATED CONTINUOUS CURRENT (A RMS) _____
- 3.7 INTERRUPTING CAPABILITY _____
- 3.8 INTERRUPT TIME (CYCLES) _____
- 3.9 CLOSING TIME (CYCLES) _____
- 3.10 CLOSE & LATCH (KA) _____
- 3.11 DUTY CYCLE _____
- 3.12 CLOSING DEVICE MAXIMUM CURRENT _____
- 3.13 TRIPPING DEVICE MAXIMUM CURRENT _____
- 3.14 NET WEIGHT (installed) _____
- 3.15 SHIPPING DATE (weeks ARO) _____
- 3.16 COMPLETE DIMENSIONS _____

4.0 NOTES

**POWER
CIRCUIT BREAKERS
DATA SHEET**

SHEET 1 OF 2
DATE SHEET NO.:
547-653-ES001-4

CLIENT: Terrebonne Parish Consolidated Government (TPCG)
PROJECT: Substation Breaker Replacements
JOB NO.: 547-653

NO.	BY	DATE	REVISION	SPEC. NO.
1	DTD	01/21/19	0	547-653-ES001
				REV. 0
				DATE 01/21/19
				P.O. NO.
				BY DTD
				CHKD
				APPR. DTD

1.0 RATINGS

- 1.1 NUMBER OF UNITS: 2
- 1.2 TAG NUMBERS (LOCATION): HB0904, HB1003
- 1.3 NOMINAL OPERATING VOLTAGE (LINE-LINE): 34.5 KV
- 1.4 MAXIMUM OPERATING VOLTAGE (LINE-LINE): 38.0 KV
- 1.5 VOLTAGE RANGE FACTOR: 1.0
- 1.6 INSULATION WITHSTAND TEST VOLTAGE, kV Crest: 200 KV
- 1.7 CONTINUOUS CURRENT: 1200 AMPERES
- 1.8 MAX. SYMMETRICAL INTERRUPTING CURRENT: 40 KA
- 1.9 FREQUENCY: 60 Hertz
- 1.10 RATED MINIMUM INTERRUPTING TIME: 3 cycles
- 1.11 DUTY CYCLE: OCO-15 sec.-CO
- 1.12 CURRENT TRANSFORMERS:
 - [X] RELAY Qty: 1 per bushing Accuracy C200 Bushings 1,2,3,4,5,6
 - Ratio: 1200-5 Amperes [X] Multi-Ratio [] Single Ratio
 - [] METERING Qty: _____ per bushing Accuracy _____ Bushings _____
 - Ratio: _____ Amperes [] Multi-Ratio [] Single Ratio
- 1.13 SUPPLY VOLTAGE: 120/240 Volts AC single phase
- 1.14 CONTROL AND TRIPPING VOLTAGE: 48 Volts DC
- 1.15 SPRING CHARGING MOTOR: 240 Volts AC
- 1.16 HEATER VOLTAGE: 240 Volts AC
- 1.17 TRIP COILS: [X] DUAL [] SINGLE
- 1.18 BREAKER MONITOR POINTS (ALARM POINTS):
 - [X] Trip Coil Monitoring Scheme [X] Loss of Charging Motor Voltage
 - [X] Loss of Close Voltage [X] Loss of Heater AC Voltage
 - [X] Spring Discharge Alarm [X] Loss of Trip DC Voltage
- 1.19 ALARM CONTACT VOLTAGE: 48 Volts DC

2.0 CONSTRUCTION

- 2.1 LOCATION: [] Indoor [X] Outdoor
- 2.2 TYPE: [X] Dead Tank [] Live Tank
- 2.3 SEISMIC REQUIREMENT: ZONE 4
- 2.4 MAXIMUM HEIGHT (excluding bushing removal): 144 inches
- 2.5 INTERRUPTING MEDIUM: VACUUM
- 2.6 FINISH PAINT: [X] ANSI No. 70 Light gray [] Other
- 2.7 BUSHING: [X] PORCELAIN [] COMPOSITE
- 2.8 ACCESSORIES:
 - [X] Rigid control cabinet with gasketed, hinged doors, pad lockable latch, and removable bottom plate for conduit entry
 - [X] Hand closing lever and a manual charging device for stored energy mechanism
 - [X] NEMA 4 hole flow tin plated pads for breaker threaded stud type bushing (Type HDSF or Equal)
 - [X] NEMA 2 hole tin plated pads for grounding
 - [X] Guarded space heater and convenience outlet
 - [X] Control Switch [X] Control Cabinet Light [X] Indicating Lights [X] Local/Remote Switch
- 2.8 PROTECTIVE RELAYS: [] YES [X] NO
- 2.9 DIMENSIONAL RESRICTIONS:
 - Height (Excluding bushing removal) 10.5 feet – Adjustable Legs 10.0 to 12'

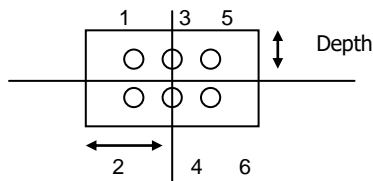

Width 7 feet Total
Depth 5 feet Total

CLIENT: Terrebonne Parish Consolidated Government (TPCG) PROJECT: Substation Breaker Replacements JOB NO.: 547-653	POWER CIRCUIT BREAKERS DATA SHEET				SHEET 2 OF 2		
					DATE SHEET NO.: 547-653-ES001-4-4		
	NO.	BY	DATE	REVISION	SPEC. NO. 547-653-ES001		
	1	DTD	01/21/19	0	REV. 0		
					DATE 01/21/19		
					P.O. NO.		
				BY DTD	CHKD	APPR. DTD	

3.0 DATA SUPPLIED BY MANUFACTURER WITH THE PROPOSAL

- 3.1 MANUFACTURER _____
- 3.2 PLACE OF MANUFACTURE _____
- 3.3 FULL WAVE BIL _____
- 3.4 RATED MAX VOLTAGE _____
- 3.5 RATED FREQUENCY _____
- 3.6 RATED CONTINUOUS CURRENT (A RMS) _____
- 3.7 INTERRUPTING CAPABILITY _____
- 3.8 INTERRUPT TIME (CYCLES) _____
- 3.9 CLOSING TIME (CYCLES) _____
- 3.10 CLOSE & LATCH (KA) _____
- 3.11 DUTY CYCLE _____
- 3.12 CLOSING DEVICE MAXIMUM CURRENT _____
- 3.13 TRIPPING DEVICE MAXIMUM CURRENT _____
- 3.14 NET WEIGHT (installed) _____
- 3.15 SHIPPING DATE (weeks ARO) _____
- 3.16 COMPLETE DIMENSIONS _____

4.0 NOTES

**POWER
CIRCUIT BREAKERS
DATA SHEET**

SHEET 1 OF 2

DATE SHEET NO.:
547-653-ES001-5

CLIENT: Terrebonne Parish Consolidated Government (TPCG)

PROJECT: Substation Breaker Replacements

JOB NO.: 547-653

NO.	BY	DATE	REVISION	SPEC. NO.
1	DTD	01/21/19	0	547-653-ES001
				REV. 0
				DATE 01/21/19
				P.O. NO.
				BY DTD
				CHKD
				APPR. DTD

1.0 RATINGS

- 1.1 NUMBER OF UNITS: 2
- 1.2 TAG NUMBERS (LOCATION): Gen. 16, B5B03
- 1.3 NOMINAL OPERATING VOLTAGE (LINE-LINE): 34.5 KV
- 1.4 MAXIMUM OPERATING VOLTAGE (LINE-LINE): 38.0 KV
- 1.5 VOLTAGE RANGE FACTOR: 1.0
- 1.6 INSULATION WITHSTAND TEST VOLTAGE, kV Crest: 200 KV
- 1.7 CONTINUOUS CURRENT: 2000 AMPERES
- 1.8 MAX. SYMMETRICAL INTERRUPTING CURRENT: 40 KA
- 1.9 FREQUENCY: 60 Hertz
- 1.10 RATED MINIMUM INTERRUPTING TIME: 3 cycles
- 1.11 DUTY CYCLE: OCO-15 sec.-CO
- 1.12 CURRENT TRANSFORMERS:
 - [X] RELAY Qty: 2 per bushing Accuracy C400 Bushings 1,2,3,4,5,6
 - Ratio: 2000-5 Amperes [X] Multi-Ratio [] Single Ratio
 - [] METERING Qty: _____ per bushing Accuracy _____ Bushings _____
 - Ratio: _____ Amperes [] Multi-Ratio [] Single Ratio
- 1.13 SUPPLY VOLTAGE: 120/208 Volts AC single phase
- 1.14 CONTROL AND TRIPPING VOLTAGE: 125 Volts DC
- 1.15 SPRING CHARGING MOTOR: 208 Volts AC
- 1.16 HEATER VOLTAGE: 208 Volts AC
- 1.17 TRIP COILS: [X] DUAL [] SINGLE
- 1.18 BREAKER MONITOR POINTS (ALARM POINTS):
 - [X] Trip Coil Monitoring Scheme [X] Loss of Charging Motor Voltage
 - [X] Loss of Close Voltage [X] Loss of Heater AC Voltage
 - [X] Spring Discharge Alarm [X] Loss of Trip DC Voltage
- 1.19 ALARM CONTACT VOLTAGE: 125 Volts DC

2.0 CONSTRUCTION

- 2.1 LOCATION: [] Indoor [X] Outdoor
- 2.2 TYPE: [X] Dead Tank [] Live Tank
- 2.3 SEISMIC REQUIREMENT: ZONE 4
- 2.4 MAXIMUM HEIGHT (excluding bushing removal): 144 inches
- 2.5 INTERRUPTING MEDIUM: VACUUM
- 2.6 FINISH PAINT: [X] ANSI No. 70 Light gray [] Other
- 2.7 BUSHING: [X] PORCELAIN [] COMPOSITE
- 2.8 ACCESSORIES:
 - [X] Rigid control cabinet with gasketed, hinged doors, pad lockable latch, and removable bottom plate for conduit entry
 - [X] Hand closing lever and a manual charging device for stored energy mechanism
 - [X] NEMA 4 hole flow tin plated pads for breaker threaded stud type bushing (Type HDSF or Equal)
 - [X] NEMA 2 hole tin plated pads for grounding
 - [X] Guarded space heater and convenience outlet
 - [X] Control Switch [X] Control Cabinet Light [X] Indicating Lights [X] Local/Remote Switch
- 2.8 PROTECTIVE RELAYS: [] YES [X] NO
- 2.9 DIMENSIONAL RESRICTIONS:
 - Height (Excluding bushing removal) 10.5 feet – Adjustable Legs 10.0 to 12'

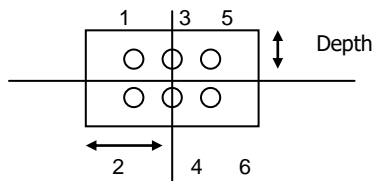

Width 7 feet Total
Depth 5 feet Total

CLIENT: Terrebonne Parish Consolidated Government (TPCG) PROJECT: Substation Breaker Replacements JOB NO.: 547-653	POWER CIRCUIT BREAKERS DATA SHEET				SHEET 2 OF 2		
					DATE SHEET NO.: 547-653-ES001-5		
	NO.	BY	DATE	REVISION	SPEC. NO. 547-653-ES001		
	1	DTD	01/21/19	0	REV. 0		
					DATE 01/21/19		
				P.O. NO.			
				BY DTD	CHKD	APPR. DTD	

3.0 DATA SUPPLIED BY MANUFACTURER WITH THE PROPOSAL

- 3.1 MANUFACTURER _____
- 3.2 PLACE OF MANUFACTURE _____
- 3.3 FULL WAVE BIL _____
- 3.4 RATED MAX VOLTAGE _____
- 3.5 RATED FREQUENCY _____
- 3.6 RATED CONTINUOUS CURRENT (A RMS) _____
- 3.7 INTERRUPTING CAPABILITY _____
- 3.8 INTERRUPT TIME (CYCLES) _____
- 3.9 CLOSING TIME (CYCLES) _____
- 3.10 CLOSE & LATCH (KA) _____
- 3.11 DUTY CYCLE _____
- 3.12 CLOSING DEVICE MAXIMUM CURRENT _____
- 3.13 TRIPPING DEVICE MAXIMUM CURRENT _____
- 3.14 NET WEIGHT (installed) _____
- 3.15 SHIPPING DATE (weeks ARO) _____
- 3.16 COMPLETE DIMENSIONS _____

4.0 NOTES

SCHEDULE OF DRAWING & OTHER DOCUMENT REQUIREMENTS

EQUIPMENT DESCRIPTION 15kV & 38kV POWER CIRCUIT BREAKERS
 SPEC/ITEM NO. JJ Bergeron Spec. 547-653-ES001

INQUIRY/P.O. NO. _____

I T E M	DOCUMENT/DATA	PDF FILE & COPIES WITH QUOTE	QUANTITIES REQUIRED AFTER PURCHASE						I T E M	DOCUMENT/DATA	PDF FILE & COPIES WITH QUOTE	QUANTITIES REQUIRED AFTER PURCHASE						
			FOR REVIEW			FINAL						FOR REVIEW			FINAL			
			PRINTS	PDF'S	DATE REQ'D	PRINTS	PDF'S	DATE REQ'D				PRINTS	PDF'S	DATE REQ'D	PRINTS	PDF'S	DATE REQ'D	
A	DIMENSIONED OUTLINE AND/OR GENERAL ARRANGEMENT DRAWINGS	3	3	1	A	3	1	E	O	RECOMMENDED SPARE PARTS & TOOLS LIST WITH PRICES	3	3	1	A	3	1	E	
B	ANCHOR BOLT LAYOUTS OR FOUNDATION PLANS	3	3	1	A	3	1	E	P	DESCRIPTION OF SUPPLIER'S QUALITY CONTROL PLAN								
C	BUSHING OUTLINE AND DATA	3	3	1	A	3	1	E	Q	INSPECTION/TEST PROCED.	3	3	1	A	3	1	E	
D	SCHEMATICS AND WIRING DIAGRAMS	3	3	1	A	3	1	E	R	INSPECTION/TEST DATA								
E	BUSHING CURRENT TRANSFORMER EXCITATION CURVES	3	3	1	A	3	1	E	S	C	1	COMPLIANCE						
F	BUSHING CURRENT TRANSFORMER OVERCURRENT RATIO CURVES	3	3	1	A	3	1	E		E	2	PERSONNEL						
G										R	3	EQUIPMENT						
H	BREAKER NAMEPLATE		3	1	A	3	1	E		T	4	TEST DATA				3	1	E
I	OPERATING MECHANISM NAMEPLATE		3	1	A	3	1	E		I	5	MILL TEST						
J	INSTRUCTION BOOKS FOR INSTALLATION AND MAINTENANCE					3		E		C	6	OTHER						

NOTE: ALL DOCUMENTS AND DATA SUBMITTALS MUST BE REFERENCED TO THE INQUIRY OR P.O. NO., SPEC ITEM NO., AND ITEM DESIGNATOR. SEE PREVIOUS PAGE FOR ADDITIONAL REQUIREMENTS.

A - 4 WEEKS AFTER RECEIPT OF ORDER
 B - PRIOR TO FABRICATION
 C - WITH SHIPMENT

D - PRIOR TO INVOICE
 E - PRIOR TO SHIPPING

SCHEDULE OF DRAWING & OTHER DOCUMENT REQUIREMENTS

EQUIPMENT
DESCRIPTION

15kV & 38kV POWER CIRCUIT BREAKERS

INQUIRY/P.O. NO. _____

SPEC/ITEM
NO.

JJ Bergeron Spec. 508-250-ES001

I T E M	DOCUMENT/DATA	PDF FILE & COPIES WITH QUOTE	QUANTITIES REQUIRED AFTER PURCHASE						I T E M	DOCUMENT/DATA	PDF FILE & COPIES WITH QUOTE	QUANTITIES REQUIRED AFTER PURCHASE					
			FOR REVIEW			FINAL						FOR REVIEW			FINAL		
			PRINTS	PDF'S	DATE REQ'D	PRINTS	PDF'S	DATE REQ'D				PRINTS	PDF'S	DATE REQ'D	PRINTS	PDF'S	DATE REQ'D
X	DESCRIPTIVE LITERATURE	3	3	1	A	3	1	E	AG	ELECTRONIC COPIES OF ALL DRAWINGS IN AUTOCAD 2014		1	1	A	1	1	E
Y	EQUIPMENT WEIGHT & CENTER OF GRAVITY	3	3	1	A	3	1	E									
Z																	
AA	SHIPPING WEIGHTS AND DIMENSIONS	3		1	A												
AB	WARRANTY INFORMATION	3	3	1	B	3	1	E									
AD	HANDLING-LIFTING INSTRUCTIONS					3	1	E									
AE	RECEIVING INSTRUCTIONS (INSPECTION & TEST)					3	1	E									
AF	STORAGE INSTRUCTIONS					3	1	E									

NOTE: ALL DOCUMENTS AND DATA SUBMITTALS MUST BE REFERENCED TO THE INQUIRY OR P.O. NO., SPEC ITEM NO., AND ITEM DESIGNATOR. SEE PREVIOUS PAGE FOR ADDITIONAL REQUIREMENTS.

A - 4 WEEKS AFTER RECEIPT OF ORDER
B - PRIOR TO FABRICATION
C - WITH SHIPMENT

D - PRIOR TO INVOICE
E - PRIOR TO SHIPPING

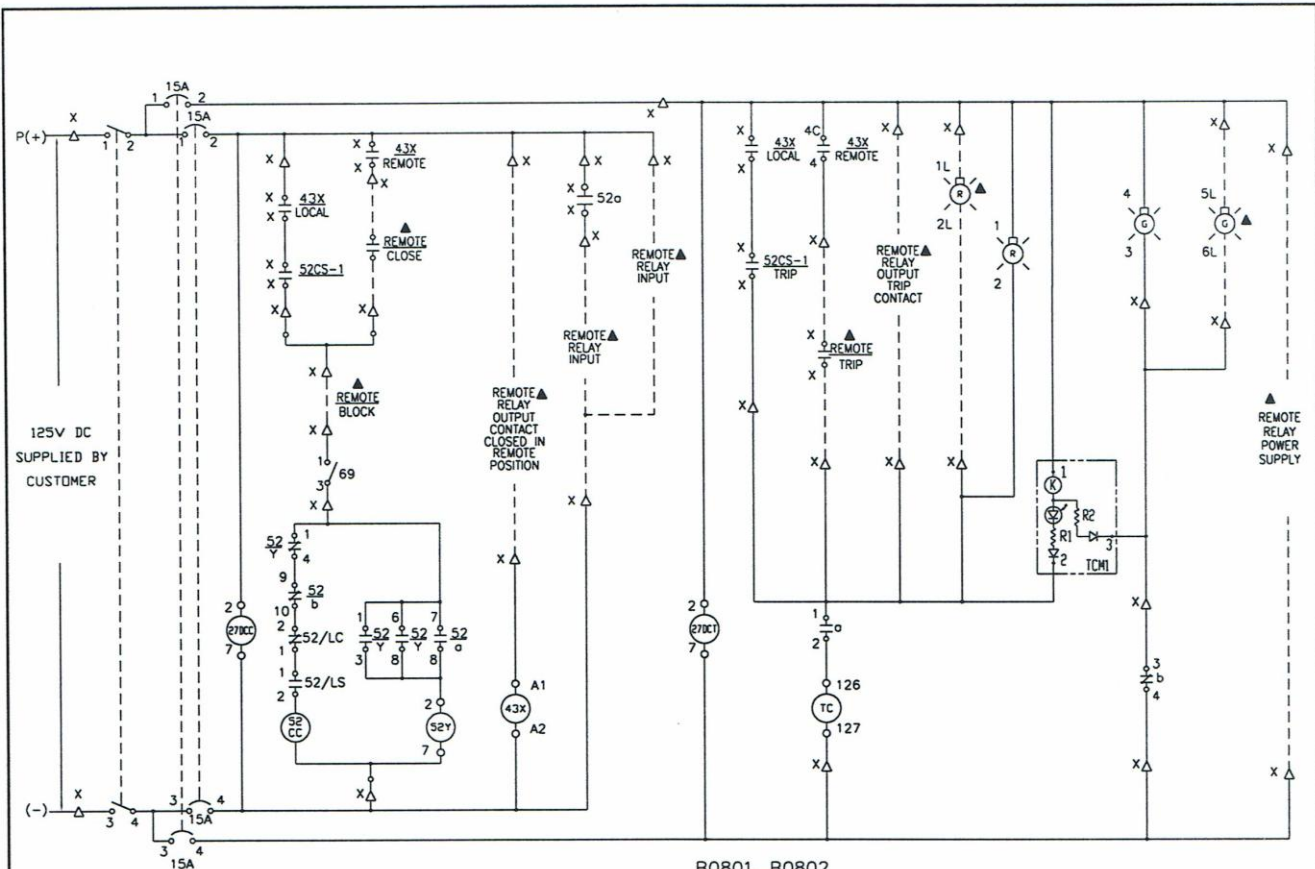

B0801, B0802
D.C. SCHEMATIC DIAGRAM

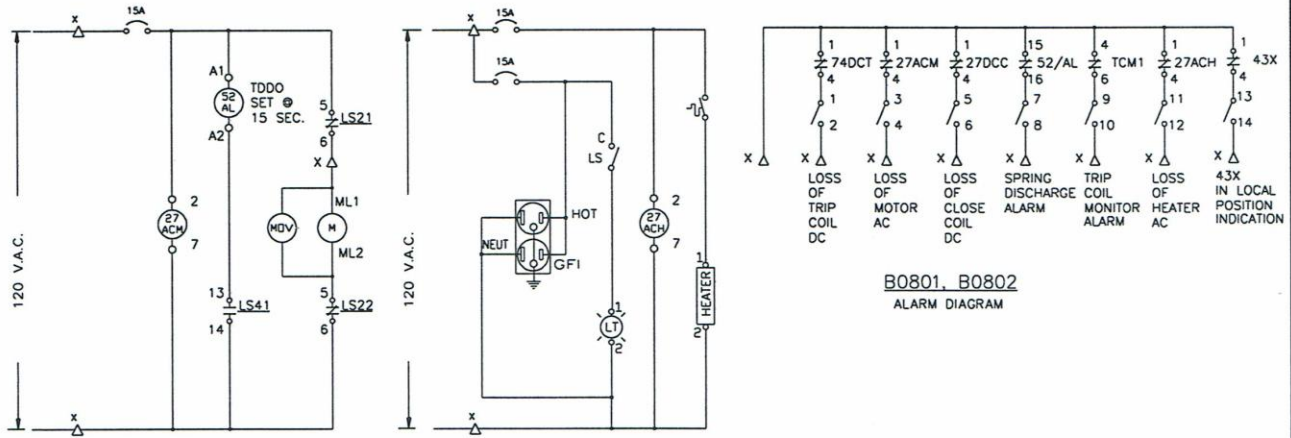

B0801, B0802
A.C. SCHEMATIC DIAGRAM

B0801, B0802
ALARM DIAGRAM

LEGEND

- ▲ DEVICE LOCATED IN CONTROL HOUSE PANELS
- △ BKR EDFOX TERMINAL BLOCK POINT
- DEVICE TERMINAL
- FIELD WIRING

TERREBONNE PARISH CONSOLIDATED GOVERNMENT

15KV OUTDOOR VACUUM CIRCUIT BREAKERS, 1200A, 25KA

BKRS B0801 AND B0802

TYPICAL 120VAC & 125VDC SCHEMATIC DIAGRAMS

J.J. BERGERON & COMPANY, INC.

METAIRIE, LOUISIANA

CLIENT NUMBER 547	JOB NUMBER 653	DRAWN BY: DTD	DATE 11/29/18	SCALE NONE	DRAWING NO. 547-653-BD1	SHT. OF SHT. 1 1
----------------------	-------------------	------------------	------------------	---------------	----------------------------	---------------------

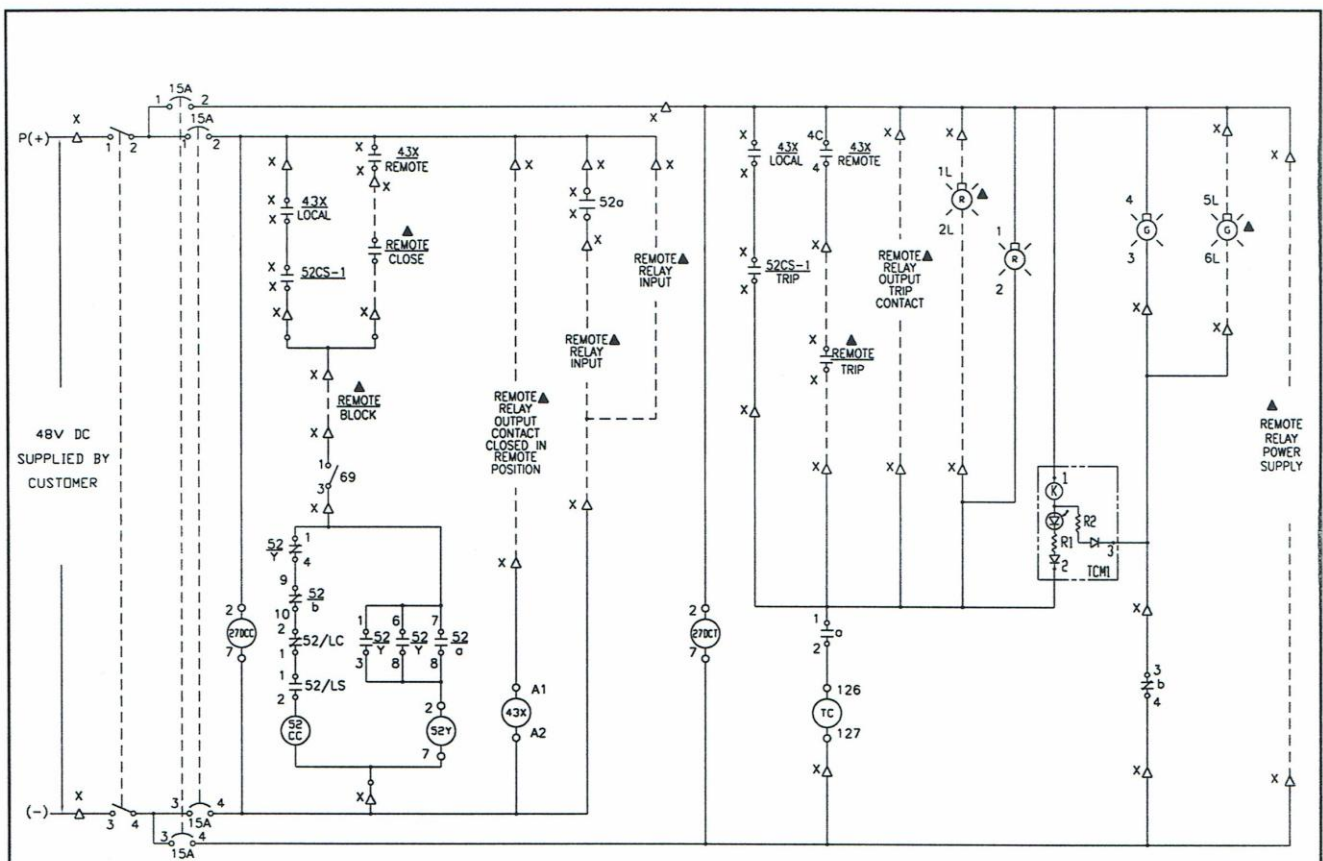

CIRCUIT BREAKER
48V D.C. SCHEMATIC DIAGRAM

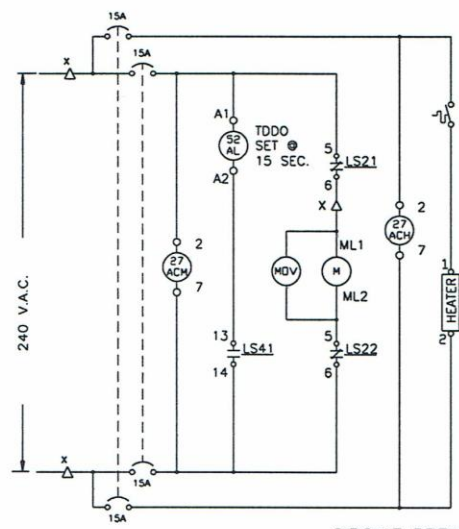

CIRCUIT BREAKER
A.C. SCHEMATIC DIAGRAM

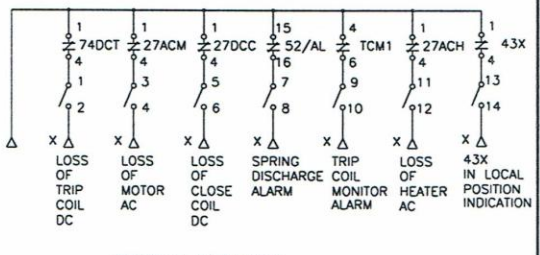
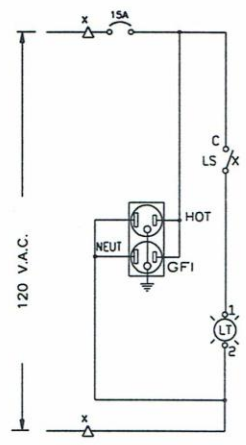

CIRCUIT BREAKER
ALARM DIAGRAM

LEGEND
 ▲ DEVICE LOCATED IN CONTROL HOUSE PANELS
 △ BKR TERMINAL BLOCK POINT
 ○ DEVICE TERMINAL
 --- FIELD WIRING

TERREBONNE PARISH CONSOLIDATED GOVERNMENT
 15KV OUTDOOR VACUUM CIRCUIT BREAKERS, 1200A, 25KA
 BKRS B0902, B0903, B0501, B0502, SWFD1
 TYPICAL 240VAC & 48VDC SCHEMATIC DIAGRAMS
 J.J. BERGERON & COMPANY, INC.
 METAIRIE, LOUISIANA

CLIENT NUMBER 547	JOB NUMBER 653	DRAWN BY: DTD	DATE 11/30/18	SCALE NONE	DRAWING NO. 547-653-BD3	SHT. OF SHT. 1 1
----------------------	-------------------	------------------	------------------	---------------	----------------------------	---------------------

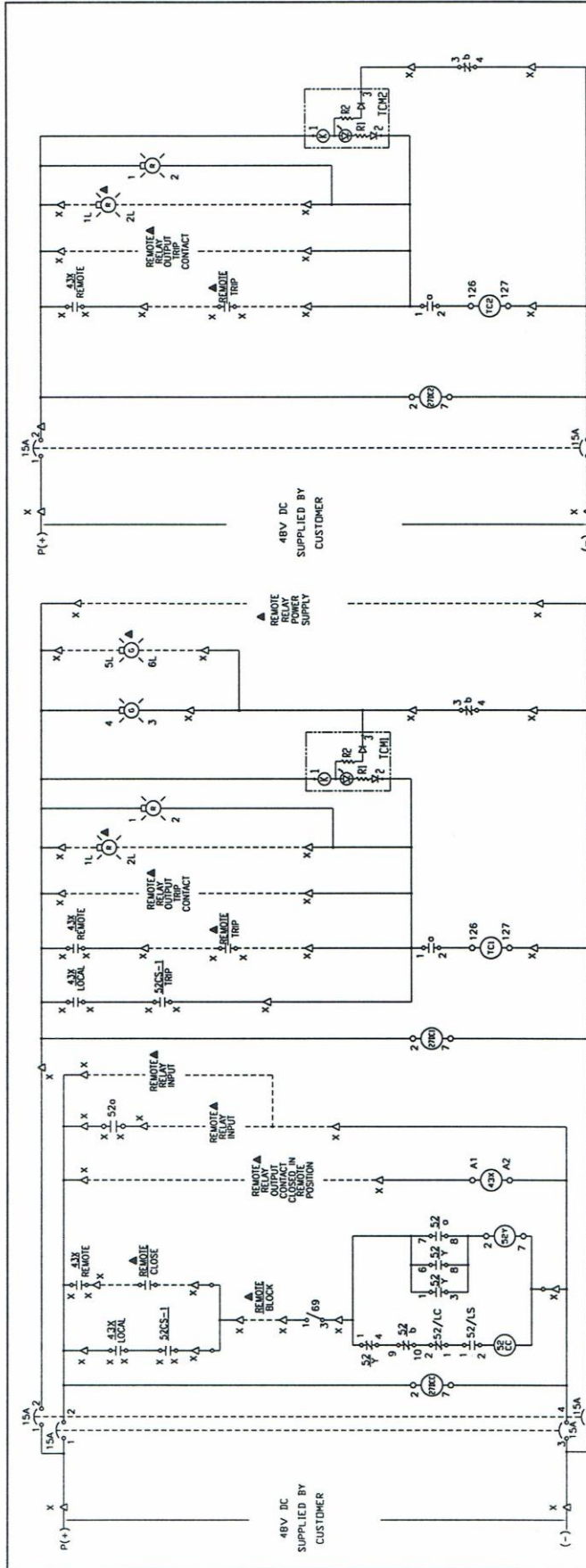

CIRCUIT BREAKER
48V D.C. SCHEMATIC DIAGRAM

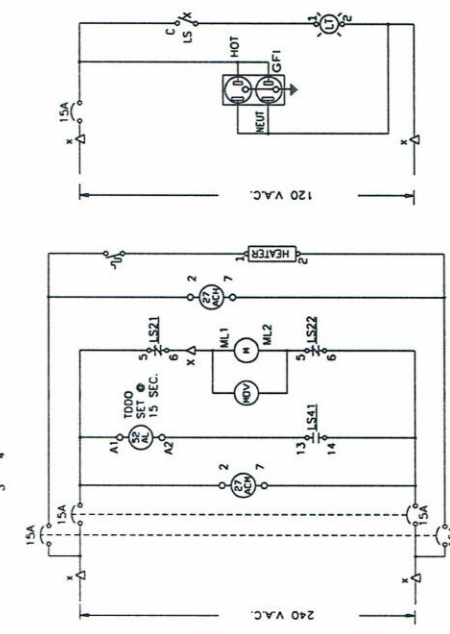

CIRCUIT BREAKER
A.C. SCHEMATIC DIAGRAM

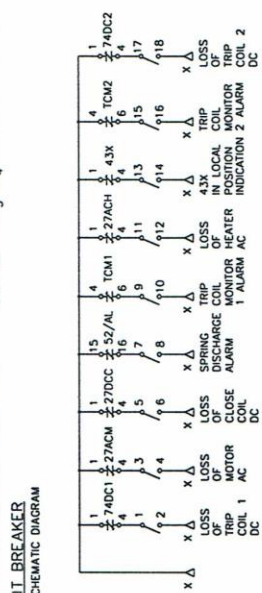

CIRCUIT BREAKER
ALARM DIAGRAM

TERREBONNE PARISH CONSOLIDATED GOVERNMENT
38KV OUTDOOR VACUUM CIRCUIT BREAKERS, 1200A, 40KA
BKRS HB0904, HB1003
TYPICAL 240VAC & 48VDC SCHEMATIC DIAGRAMS
J.J. BERGERON & COMPANY, INC.
METAIRIE, LOUISIANA

CLIENT NUMBER 547	JOB NUMBER 653	DRAWN BY: DTD	DATE 11/30/18	SCALE NONE	DRAWING NO. 547-653-BD4	SHT. OF SHT. 1
----------------------	-------------------	------------------	------------------	---------------	----------------------------	-------------------

