

**CITY OF SAN ANTONIO
TRANSPORTATION AND CAPITAL IMPROVEMENTS**



SPECIFICATIONS

FOR

2019 RECLAMATION RECONSTRUCTION TASK ORDER PACKAGE 7

**CITY MANAGER
SHERYL L. SCULLEY**

**DIRECTOR OF TRANSPORTATION AND CAPITAL IMPROVEMENTS
MIKE FRISBIE, P.E.**

Prepared By:



**Lockwood, Andrews
& Newnam, Inc.**

A LEO A DALY COMPANY

Firm ID No. 2614

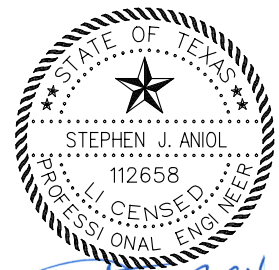

A handwritten signature in blue ink that reads 'Stephen J. Aniol'.

8/8/2018

10101 REUNION PLACE, STE. 200
SAN ANTONIO, TEXAS 78216

AUGUST 2018

TABLE OF CONTENTS

<u>SPECIFICATIONS:</u>	<u>PAGE REFERENCE</u>
Project Description	PD-1 – PD-2
Bid Form (Form 020)	1 PAGE
Unit Pricing Form (Form 025)	4 PAGES
Governing Specifications, Special Provisions, Supplemental Specifications And Special Specifications	GSSP-1 – GSSP-6
Special Provision to Item 100 – Mobilization	1 PAGE
Special Provision to Item 101 – Preparing Right-of-Way	1 PAGE
Special Provision to Item 205 – Hot Mix Asphaltic Concrete Pavement	2 PAGES
Special Provision to Item 500 – Concrete Curb	1 PAGE
Special Provision to Item 502 – Concrete Sidewalks	4 PAGES
Special Provision to Item 503 – Asphaltic Concrete, Portland Cement Concrete, and Gravel Driveways	2 PAGES
Special Provision to Item 505 – Concrete Riprap	1 PAGE
Special Provision to Item 513 – Removing & Relocation Mailboxes	4 PAGES
Special Provision to Item 520 – Hydromulching	1 PAGE
Special Provision to Item 523 – Adjusting of Vehicular & Pedestrian Gates	2 PAGES
Special Provision to Item 530 – Barricades, Signs & Traffic Handling	1 PAGE
Special Provision to Item 535 – Hot Applied Thermoplastic Pavement Markings	1 PAGE
Special Provision to Item 536 – Preformed Pavement Markings	1 PAGE
Special Provision to Item 540 – Temporary Erosion, Sedimentation & Water Pollution Prevention and Control	2 PAGES
Special Provision to Item 556 – Cast in Place Detectable Warning Surface Tiles	1 PAGE
Special Provisions to Item 851 – Adjusting Existing Manhole	1 PAGE
Supplemental Specification 1 – Removing and Relocating Sign	1 PAGE

Supplemental Specification 2 – Elevated Sidewalk	3 PAGES
Supplemental Specification 3 – Sidewalk Drain Box	3 PAGES
Supplemental Specification 4 – Removal of Existing Rock/Masonry Mail Box	1 PAGE
Supplemental Specification 5 – Tree Removal	1 PAGE
Supplemental Specification 6 – Adjusting Traffic Signal Box	1 PAGE
Supplemental Specification 7 – TCI Project Sign	1 PAGE
Supplemental Specification 8 – Police Officer	1 PAGE
Supplemental Specification 9 – Removal of Existing Asphalt Speed Hump	1 PAGE
Supplemental Specification 10 – Removal of Speed Hump, Type II Modular Rubber Cushion	1 PAGE
Supplemental Specification 11 – Adjusting Metal Beam Guardrail	1 PAGE
Supplemental Specification 12 – Door Hangers	1 PAGE
Supplemental Specification 13 – Portable Changeable Message Sign (Electronic Message Board)	1 PAGE
Supplemental Specification 14 – Additional Mobilization	1 PAGE
Supplemental Specification 15 – Remove and Relocate Customer Shutoff Valve	1 PAGE
Supplemental Specification 16 – Remove and Relocate Backflow Preventer	1 PAGE
Supplemental Specification 17 – Remove and Relocate Pressure Reducing Valve	1 PAGE
Item No. 250 Seal Coat	3 PAGES
Item No. 344 Superpave Mixtures (TXDOT)	28 PAGES
Item No. 800 Speed Humps, 12-Foot Parabolic Asphalt Concrete Humps	4 PAGES
Item No. 801 Tree and Landscape Protection	3 PAGES
Item No. 802 Tree Pruning, Soil Amending, and Fertilization	5 PAGES
Item No. 804 New Tree & Shrub Planting and Maintenance	4 PAGES
Item No. 826-A Locating & Adjusting Existing Valve boxes	1 PAGE

Item No. 851-A Locating & Adjusting Existing Manholes	1 PAGE
TCI Project Sign Detail	1 PAGE
Manhole Encasement Detail	1 PAGE
COSA Miscellaneous Construction Standards I (Revised)	1 PAGE
COSA Miscellaneous Construction Standards II (Revised)	1 PAGE
COSA Concrete Driveway Standards (Revised)	1 PAGE
COSA Wheelchair Ramp Standards (Revised)	1 PAGE
COSA Concrete Bus Stop Pad	1 PAGE
COSA Elevated Sidewalk and Retard Standard (Revised)	1 PAGE
COSA 12-Foot Parabolic Asphalt Concrete Speed Hump Detail	2 PAGES
COSA Chain Link Wire Fence Standards	1 PAGE
COSA Tree Protection Details	1 PAGE
COSA Temporary Erosion, Sediment & Water Pollution Control Measures Standards I	1 PAGE
COSA Temporary Erosion, Sediment & Water Pollution Control Measures Standards II	1 PAGE
COSA Barricade & Construction Standards	4 PAGES
TxDOT Pedestrian Facilities – Curb Ramps (Revised)	2 PAGES
TxDOT Portable Changeable Message Sign (PCMS) BC (6)-13	1 PAGE
General Notes for Reclamation and Reconstruction Projects	4 PAGES

Project Description

Project Duration

This contract shall be terminated one hundred and eighty (180) calendar days after issuance of the first task order. The construction time (in calendar days) for each individual street will be negotiated between the City Engineer or Project Manager and the Contractor. The Contractor will be expected to begin construction for each individual site in accordance with Article 1- General Provisions, Section 1.2.4, Notice to Proceed and Commencement of Contract Times in the General Conditions-City of San Antonio Construction Contracts. The Contractor may also be limited to the amount of individual project sites open at any given time depending on resources and performance. Liquidated damages for construction time will be assessed on a per task order basis should the contractor fail to complete the construction in the specified calendar days as negotiated by the City Engineer or Project Manager.

Task Order Duration

The contractor will negotiate calendar days for each street issued by the City as part of each task order. Contractor will not receive the full 180 calendar days to complete each street due to City fiscal year goals. If contractor exceeds calendar days for specified street, liquidated damages will be assessed.

Project Scope

Project construction may include but is not limited to: full reconstruction, subgrade treatment, base and surface coarse installations, full depth reclamation, cement and emulsion treatment, base and pavement replacement, concrete curbs, sidewalks, driveways, concrete retaining walls-combination type, concrete bus pads, wheel chair ramps, removing and relocating mail boxes, asphalt speed humps, topsoil, sodding, signage, striping, elevated sidewalks, sidewalk pipe railing, adjusting existing meter boxes, valve boxes and manholes, tree pruning, removal and/or replacement, and any other items required due to the site conditions to accomplish the project scope.

Quantities included in this contract, as well as the entire bid amount are not guaranteed. Unit prices established shall remain valid throughout the duration of this contract.

Important Notes

No direct payment shall be made for the following specification items, unless specifically listed in the 025 unit pricing form. Contractor shall include cost of these items in various other bid items:

- 100.1 Mobilization
- 100.2 Insurance and Bond
- 101.1 Preparing Right-of-Way
- 530.1 Barricades, Signs, and Traffic Handling
- 540 Temporary Erosion, Sedimentation and Water Pollution Prevention and Control

Excavation due to construction of curb, sidewalk, retaining walls, driveways, and parkway grading (edge of pavement/curb to property line) shall not be paid for directly but shall be included in various other bid items of which it forms a component part.

Removal of roadway material and/or subgrade will be paid under Item 104 street excavation, regardless of means and methods utilized by Contractor.

Concrete Curb, Curb and Gutter, and Mountable (Roll Over) Curb:

Reference special provision to Item 500 for payment on different curb types.

Concrete Sidewalk Drain:

Concrete sidewalk drain shall be installed in accordance with Revised Miscellaneous Construction Standards I Detail.

Traffic Control

A traffic control plan (TCP) shall be completed for every project. If the Contractor chooses to use TxDOT or CoSA standards, then providing a TCP signed by a Texas Licensed PE is not required. Should the Contractor choose to deviate from available TCP standards, then the Contractor must submit a detailed TCP signed and sealed by a Texas Licensed PE at no additional cost to the City.

All City of San Antonio Specifications & Construction Detail sheets available on the City's Website at:

<http://www.sanantonio.gov/TCI/CurrentVendorResources/StandardSpecificationsandDetails.aspx>

All Construction and Material Specifications for SAWS bid items are available at:

http://www.saws.org/business_center/specs/constspecs/

http://www.saws.org/business_center/specs/matspecs/

The Specific Contract Documents for this project are available on the City's Website at:

<http://www.sanantonio.gov/RFPListings/RFPList.aspx>

Click on the following link "FY 2019 Reclamation Reconstruction Task Order Package 7"

CITY OF SAN ANTONIO

Project Name: FY 2019 Reclamation Reconstruction Task Order Package
7 ID NO.: 23-01760-08-02

Date Issued: August 10, 2018
Page 1 of 1

The estimated construction budget for this contract is \$2,000,000.00

020 BID FORM

Legal Name of Company (print)

I. BASE BID

Total Amount of Base Bid (CoSA + SAWS + CPS Energy) (Insert Amount in Words and Numbers):

\$ _____

Person Authorized to Sign Bid/Contract (Print)

Title of Person Signing

Address

Fax No.

City, State and Zip Code

Local Headquarters
 Local Branch Office (Check one)

Telephone No.

E-mail Address

Name of the proposed **Project Manager**: _____

Name of the proposed **Site Superintendent**: _____

CITY OF SAN ANTONIO
025 UNIT PRICING FORM

PROJECT NAME: FY 2019 RECLAMATION RECONSTRUCTION TASK ORDER PACKAGE 7
PROJECT NO. 23-01760-08-02

ITEM NO.	DESC. CODE	S.P. NO	BID ITEM DESCRIPTION	UNIT OF MEASURE	APPROX. QUANTITIES	UNIT BID PRICE	AMOUNT	ITEM SEQUENCE NO.
			The City only will accept bid pricing to the hundredths. Any pricing extended out to three decimal points will be truncated to two decimal points in the City's favor.					
BASE BID								
COSA								
103.1			REMOVE CONCRETE CURB	LF	7,000			
103.3			REMOVE SIDEWALKS AND DRIVEWAYS	SF	20,000			
103.4			REMOVE MISCELLANEOUS CONCRETE	SF	350			
104.1			STREET EXCAVATION	CY	2,750			
107.1			EMBANKMENT (FINAL) (ORDINARY COMPACTION) (TY B)	CY	50			
108.1			LIME TREATED SUBGRADE	SY	5,000			
108.2			LIME	TON	70			
109.1			CEMENT TREATED SUBGRADE (6-INCH COMPACTED DEPTH)	SY	3,400			
109.2			CEMENT	TON	50			
200.1A			FLEXIBLE BASE (10-INCH COMPACTED DEPTH)	SY	3,400			
200.2			FLEXIBLE BASE (LOOSE)	CY	350			
201.1			CEMENT TREATMENT (EXISTING MATERIAL) (6-COMPACTED DEPTH)	SY	3,400			
201.4			CEMENT	TON	50			
202.1			PRIME COAT	GAL	750			
203.1			TACK COAT	GAL	1,700			
205.2			HOT MIX ASPHALTIC PAVEMENT, TYPE B (6-INCH COMPACTED DEPTH)	TON	3,875			
205.2			HOT MIX ASPHALTIC PAVEMENT, TYPE B (8-INCH COMPACTED DEPTH)	TON	975			
205.4			HOT MIX ASPHALTIC PAVEMENT, TYPE D (2-INCH COMPACTED DEPTH)	TON	1,500			
209.1			BUS STOP CONCRETE PAVEMENT (10" DEPTH)	SY	335			
230.3A			REPLACING BASE & PAVEMENT WITH TYPE B PVMT (6-INCH COMPACTED DEPTH)	TON	500			
230.3B			REPLACING BASE & PAVEMENT WITH TYPE B PVMT (12-INCH COMPACTED DEPTH)	TON	150			
236.1			EMULSION (CSS-1H)	GAL	11,750			
236.2			EMULSION TREATMENT (EXISTING BASE) (6-INCH COMPACTED DEPTH)	SY	4,350			
236.3			EMULSION TREATMENT (MIXING EXISTING MATERIAL AND NEW BASE) (6-INCH COMPACTED DEPTH)	SY	750			
250			SEAL COAT	SY	8,500			
344			SUPERPAVE MIXTURES SP-D SAC-A PG76-22 (2-INCH COMPACTED DEPTH)	TON	400			

CITY OF SAN ANTONIO
025 UNIT PRICING FORM

PROJECT NAME: FY 2019 RECLAMATION RECONSTRUCTION TASK ORDER PACKAGE 7
PROJECT NO. 23-01760-08-02

ITEM NO.	DESC. CODE	S.P. NO	BID ITEM DESCRIPTION	UNIT OF MEASURE	APPROX. QUANTITIES	UNIT BID PRICE	AMOUNT	ITEM SEQUENCE NO.
500.1			CONCRETE CURB	LF	7,500			
500.2			CONCRETE CURB AND GUTTER	LF	1,000			
500.3			CONCRETE MOUNTABLE CURB	LF	500			
502.1			CONCRETE SIDEWALKS	SY	5,250			
502.3			CONCRETE SIDEWALKS (COMMERCIAL STRENGTH)	EA	100			
503.1			PORTLAND CEMENT CONCRETE DRIVEWAY	SY	1,750			
503.2			PORTLAND CEMENT CONCRETE DRIVEWAY - COMMERCIAL	SY	500			
505.1			CONCRETE RIPRAP (5" THICK)	SY	100			
506.1			CONCRETE RETAINING WALLS - COMBINATION TYPE	CY	25			
507.1			CHAIN LINK FENCE - 4 FT HIGH	LF	75			
507.2			CHAIN LINK FENCE - 6 FT HIGH	LF	75			
507.4			GATES - PEDESTRIAN	EA	4			
507.5			GATES - VEHICULAR	OPEN	8			
508.1			RELOCATING WIRE FENCE	LF	80			
508.2A			RELOCATING WROUGHT IRON FENCE	LF	60			
510.1			TIMBER GUARD POSTS (< 50 UNITS)	EA	15			
512.1A			ADJUSTING EXISTING MANHOLES (STORM SEWER)	EA	5			
512.1B			ADJUSTING EXISTING MANHOLES (AT&T)	EA	3			
513.1			REMOVING AND RELOCATING MAIL BOXES	EA	100			
513.2			COMMUNITY MAILBOX SLAB	SY	100			
513.3			DECORATIVE MAILBOX (GIBRALTAR, #PED0000B)	EA	25			
515.1			TOPSOIL	CY	1,000			
516.1			BERMUDA SODDING	SY	4,000			
516.2			ST. AUGUSTINE SODDING	SY	4,000			
520.1			HYDROMULCHING (RESIDENTIAL OR COMMERCIAL)	SY	300			
522.1			SIDEWALK PIPE RAILING	LF	70			
523.1			ADJUSTING CHAIN LINK VEHICULAR GATE	EA	15			
523.3			ADJUSTING CHAIN LINK PEDESTRIAN GATE	EA	5			
523.4			ADJUSTING WROUGHT IRON VEHICULAR GATE	EA	3			
523.6			ADJUSTING WROUGHT IRON PEDESTRIAN GATE	EA	3			
524.1			CONCRETE STEPS	CY	25			
531.3			R1-1 STOP (30")(HIGH DENSITY)	EA	15			
531.5			R1-4 ALL WAY PLATE (18"X6")(HIGH DENSITY)	EA	7			
531.21			R7-1 NO PARKING ANYTIME (18"X24")(HIGH DENSITY)	EA	5			
531.44			W16-7 DIAGONAL ARROW SIGN	EA	10			

CITY OF SAN ANTONIO
025 UNIT PRICING FORM

PROJECT NAME: FY 2019 RECLAMATION RECONSTRUCTION TASK ORDER PACKAGE 7
PROJECT NO. 23-01760-08-02

ITEM NO.	DESC. CODE	S.P. NO	BID ITEM DESCRIPTION	UNIT OF MEASURE	APPROX. QUANTITIES	UNIT BID PRICE	AMOUNT	ITEM SEQUENCE NO.
531.52			W13-1 ADVISORY SPEED SIGN (20 MPH)	EA	5			
531.57			9 INCH [229MM] STREET NAME, BLOCK NUMBER (VARIES X9")(HIGH DENSITY)	EA	15			
531.59			W17-3 SPECIAL SIGN (HUMP AHEAD SYMBOL SIGN)	EA	6			
531.59			W17-3 SPECIAL SIGN (HUMP SYMBOL SIGN)	EA	12			
535.1			4-INCH WIDE YELLOW LINE	LF	2,500			
535.2			4-INCH WIDE WHITE LINE	LF	1,250			
535.4			8-INCH WIDE WHITE LINE	LF	100			
535.8			RIGHT WHITE ARROW	EA	5			
535.9			LEFT WHITE ARROW	EA	5			
535.1			COMBINATION THRU/RIGHT WHITE ARROW	EA	5			
535.11			COMBINATION THRU/LEFT WHITE ARROW	EA	5			
535.12			WORD "ONLY"	EA	5			
535.13			STRAIGHT WHITE ARROW	EA	5			
535.16			STRAIGHT WHITE ARROW BICYCLE FACILITY	EA	5			
535.17			BICYCLE RIDER SYMBOL	EA	5			
535.22			WHITE SHARROW (BIKE SHARED LANE)	EA	5			
536.5			12-INCH WIDE WHITE LINE	LF	100			
536.7			24-INCH WIDE WHITE LINE	LF	400			
536.22			12-INCH WIDE BLACK LINE (CONTRAST)	LF	600			
536.23			24-INCH WIDE YELLOW LINE	LF	50			
537.1			TRAFFIC BUTTON (TYPE W)	EA	50			
537.2			TRAFFIC BUTTON (TYPE Y)	EA	50			
537.6			PAVEMENT MARKER (TYPE I-C)	EA	80			
537.8			PAVEMENT MARKER (TYPE II A-A)	EA	125			
537.9			PAVEMENT MARKER (TYPE II C-R)	EA	50			
540.1A			ROCK FILTER DAMS (INSTALL/REMOVE) TYPE 2	LF	50			
540.1B			ROCK FILTER DAMS (SACK GABIONS) (INSTALL/REMOVE) TYPE 4	LF	50			
540.10			CURB INLET GRAVEL FILTERS	LF	100			
552.1			REMOVING AND RELOCATING IRRIGATION SYSTEMS	LF	1,200			
556.1			CAST IN PLACE DETECTABLE WARNING SURFACE TILES	EA	20			
800			SPEED HUMP, 12-FOOT PARABOLIC ASPHALT CONCRETE HUMP	LF	150			
801.2			LEVEL IIA PROTECTIVE FENCING	LF	200			
801.3			LEVEL IIB PROTECTIVE FENCING	LF	75			
802.1			LEVEL II PRUNING	EA	20			
804.1			TREE INSTALLATION (3-INCH CALIPER)	EA	7			

CITY OF SAN ANTONIO
025 UNIT PRICING FORM

PROJECT NAME: FY 2019 RECLAMATION RECONSTRUCTION TASK ORDER PACKAGE 7
PROJECT NO. 23-01760-08-02

ITEM NO.	DESC. CODE	S.P. NO	BID ITEM DESCRIPTION	UNIT OF MEASURE	APPROX. QUANTITIES	UNIT BID PRICE	AMOUNT	ITEM SEQUENCE NO.
SAWS SANITARY SEWER BID ITEMS								
851			ADJUSTING EXISTING MANHOLE	EA	12			
851A			LOCATING & ADJUSTING EXISTING MANHOLE	EA	3			
854.1			ADJUSTING EXISTING SANITARY SEWER CLEANOUT	EA	5			
Subtotal SAWS Sanitary Sewer Base Bid Amount:								
Total SAWS Base Bid Amount:								
CPS Energy BID ITEMS								
512.3			VALVE BOX ADJUSTMENT	EA	10			
Total CPS Base Bid Amount:								
Total (CoSA + SAWS + CPS) Base Bid Amount:								

_____ certifies that the unit prices shown on this complete computer print-out for all of the bid items and the alternates contained in this proposal are the unit prices intended and that its bid will be tabulated using these unit prices and no other information from this print-out.

_____ Acknowledged and agrees that the total bid amount shown will be read as its total bid and further agrees that the official total bid amount will be determined by multiplying the unit bid prices shown in this print-out by the respective estimated quantities shown in the proposal and then totaling all of the extended amounts. _____ agrees to the terms, conditions, and requirements of the bidder's bid proposal.

Signed: _____ Date: _____

Title: _____

CITY OF SAN ANTONIO, TEXAS

GOVERNING SPECIFICATIONS, SPECIAL SPECIFICATIONS, SPECIAL
PROVISIONS, AND SUPPLEMENTAL SPECIFICATIONS
FOR

2019 Reclamation Reconstruction Task Order Package 7

All Standard Specifications and Special Specifications applicable to this project are identified as follows:

CITY OF SAN ANTONIO STANDARD SPECIFICATIONS FOR CONSTRUCTION
JUNE, 2008 AND SPECIAL PROVISIONS DATED MAY 2009, FEBRUARY 2010,
JUNE 2010 and NOVEMBER 2013

<u>ITEM</u>	<u>DESCRIPTION</u>
100	- MOBILIZATION
101	- PREPARING RIGHT-OF-WAY
103	- REMOVE CONCRETE
104	- STREET EXCAVATION
107	- EMBANKMENT
108	- LIME TREATED SUBGRADE
109	- CEMENT TREATED SUBGRADE
200	- FLEXIBLE BASE
201	- CEMENT TREATED BASE
202	- PRIME COAT
203	- TACK COAT
204	- SURFACE TREATMENTS
205	- HOT MIX ASPHALTIC CONCRETE PAVEMENT
209	- CONCRETE PAVEMENT

- 210 - ROLLING
- 220 - BLADING
- 230 - BASE AND PAVEMENT REPLACEMENT
- 236 - FULL DEPTH RECLAMATION
- 300 - CONCRETE
- 301 - REINFORCING STEEL
- 302 - METAL FOR STRUCTURES
- 303 - WELDED WIRE FLAT SHEETS
- 307 - CONCRETE STRUCTURES
- 311 - CONCRETE SURFACE FINISH
- 407 - CONCRETE ENCASEMENT, CRADLES, SADDLES, AND COLLARS
- 500 - CONCRETE CURB, GUTTER, AND CONCRETE CURB AND GUTTER
- 502 - CONCRETE SIDEWALKS
- 503 - ASPHALTIC CONCRETE, PORTLAND CEMENT CONCRETE, AND GRAVEL DRIVEWAYS
- 505 - CONCRETE RIPRAP
- 506 - CONCRETE RETAINING WALLS – COMBINATION TYPE
- 507 - CHAIN LINK WIRE FENCE
- 508 - RELOCATING WIRE FENCE
- 509 - METAL BEAM GUARD RAIL
- 510 - TIMBER GUARD POSTS
- 512 - ADJUSTING EXISTING MANHOLES AND VALVE BOXES
- 513 - REMOVING AND RELOCATION MAILBOXES
- 514 - PAINT AND PAINTING

- 515 - TOPSOIL
- 516 - SODDING
- 520 - HYDROMULCHING
- 522 - SIDEWALK PIPE RAILING
- 523 - ADJUSTING OF VEHICULAR AND PEDESTRIAN GATES
- 524 - CONCRETE STEPS
- 530 - BARRICADES, SIGNS, AND TRAFFIC HANDLING
- 531 - SIGNS
- 533 - CLEANING AND REMOVAL OF PAVEMENT MARKINGS AND MARKERS
- 535 - HOT APPLIED THERMOPLASTIC PAVEMENT MARKINGS
- 536 - PREFORMED PAVEMENT MARKINGS
- 537 - RAISED PAVEMENT MARKERS
- 540 - TEMPORARY EROSION, SEDIMENTATION AND WATER POLLUTION PREVENTION AND CONTROL
- 556 - CAST IN PLACE DETECTABLE WARNING SURFACE TILES
- 1000 - WEB PORTAL

SAN ANTONIO WATER SYSTEM
STANDARD SPECIFICATIONS FOR CONSTRUCTION

- 824 - SERVICE SUPPLY LINES
- 826 - VALVE BOX ADJUSTMENT
- 833 - METER AND METER BOX INSTALLATION
- 851 - ADJUSTING EXISTING MANHOLE
- 854 - SANITARY SEWER LATERALS
SPECIAL PROVISIONS FOR CONSTRUCTION

- 100 - MOBILIZATION
- 101 - PREPARING RIGHT-OF-WAY
- 205 - HOT MIX ASPHALTIC CONCRETE PAVEMENT
- 500 - CONCRETE CURB, GUTTER AND CONCRETE CURB AND GUTTER
- 502 - CONCRETE SIDEWALKS
- 503 - ASPHALTIC CONCRETE, PORTLAND CEMENT CONCRETE, AND GRAVEL DRIVEWAYS
- 505 - CONCRETE RIPRAP
- 509 - METAL BEAM GUARD RAIL
- 513 - REMOVING & RELOCATING MAILBOXES
- 520 - HYDROMULCHING
- 523 - ADJUSTING OF VEHICULAR AND PEDESTRIAN GATES
- 530 - BARRICADES, SIGNS AND TRAFFIC HANDLING
- 535 - HOT APPLIED THERMOPLASTIC PAVEMENT MARKINGS
- 536 - PREFORMED PAVEMENT MARKINGS
- 540 - TEMPORARY EROSION, SEDIMENTATION AND WATER POLLUTION PREVENTION AND CONTROL
- 556 - CAST IN PLACE DETECTABLE WARNING SURFACE TILES
- 851 - ADJUSTING EXISTING MANHOLES

SUPPLEMENTAL SPECIFICATIONS FOR CONSTRUCTION

SUP 1 – REMOVING AND RELOCATION SIGN

SUP 2 – ELEVATED SIDEWALK

SUP 3 – SIDEWALK DRAIN BOX

SUP 4 – REMOVAL OF EXISTING ROCK/MASONRY MAILBOX

SUP 5 – TREE REMOVAL

SUP 6 – ADJUSTING TRAFFIC SIGNAL BOX

SUP 7 – TCI PROJECT SIGN

SUP 8 – POLICE OFFICER

SUP 9 – REMOVAL OF EXISTING ASPHALT SPEED HUMP

SUP 10 – REMOVAL OF SPEED HUMP, TYPE II MODULAR RUBBER CUSHION

SUP 11 – ADJUSTING METAL BEAM GUARD FENCE

SUP 12 – DOOR HANGERS

SUP 13 – PORTABLE CHANGEABLE MESSAGE SIGN (ELECTRONIC MESSAGE BOARD)

SUP 14 – ADDITIONAL MOBOLIZATION

SUP 15 – REMOVE AND RELOCATE CUSTOMER SHUTOFF VALVE

SUP 16 – REMOVE AND RELOCATE BACKFLOW PREVENTER

SUP 17 – REMOVE AND RELOCATE PRESSURE REDUCING VALVE

SPECIAL SPECIFICATIONS FOR CONSTRUCTION

ITEM 250 – SEAL COAT

ITEM 344 – SUPERPAVE MIXTURES (TXDOT)

ITEM 800 – SPEED HUMPS, 12-FOOT PARABOLIC ASPHALT CONCRETE HUMPS

ITEM 801 – TREE AND LANDSCAPE PROTECTION

ITEM 802 – TREE PRUNING, SOIL AMENDING, AND FERTILIZATION

ITEM 804 – NEW TREE AND SHRUB PLANTING AND MAINTENANCE

ITEM 826A – VALVE BOX LOCATE AND ADJUSTMENT

ITEM 851A – MANHOLE LOCATE AND ADJUSTMENT

SPECIAL DETAILS FOR CONSTRUCTION

COSA TCI PROJECT SIGN DETAIL

MANHOLE ENCASEMENT DETAIL

COSA 12-FOOT PARABOLIC ASPHALT SPEED HUMP DETAIL

COSA TREE PROTECTION DETAILS

COSA MISCELLANEOUS CONSTRUCTION STANDARDS I (REVISED)

COSA MISCELLANEOUS CONSTRUCTION STANDARDS II (REVISED)

COSA CONCRETE DRIVEWAY STANDARDS (REVISED)

COSA WHEELCHAIR RAMP STANDARDS (REVISED)

COSA CONCRETE BUS PAD STANDARD

COSA ELEVATED SIDEWALK AND RETARD STANDARDS DETAILS (REVISED)

COSA CHAINLINK WIRE FENCE STANDARDS

COSA TEMPORARY EROSION, SEDIMENT AND WATER POLLUTION CONTROL
MEASURES STANDARDS I

COSA TEMPORARY EROSION, SEDIMENT AND WATER POLLUTION CONTROL
MEASURES STANDARDS II

COSA BARRICADE AND CONSTRUCTION STANDARDS

TXDOT PEDESTRIAN FACILITIES – CURB RAMPS (REVISED)

TXDOT PORTABLE CHANGEABLE MESSAGE SIGN (PCMS) BC (6)-13

SPECIAL NOTES FOR CONSTRUCTION

GENERAL NOTES FOR RECLAMATION AND RECONSTRUCTION PROJECTS

SPECIAL PROVISION

Item 100 Mobilization

Delete:

- **Section 100.2 Measurement in its entirety**
- **Section 100.3 Payment in its entirety**
- **Section 100.4 Bid Item in its entirety**

Add:

100.2 Measurement:

Mobilization and Insurance/Bond will not be measured for payment for this contract.

100.3 Payment:

Payment will not be made for Mobilization and Insurance/Bond under this contract. Cost incurred for these items shall be considered subsidiary.

SPECIAL PROVISION

Item 101 Preparing Right-of-Way

Delete:

- **Section 101.5 Measurement in its entirety**
- **Section 101.6 Payment in its entirety**
- **Section 101.7 Bid Item in its entirety**

Add:

101.5 Measurement:

“Preparing Right-of-Way” will not be measured for payment for this contract.

101.6 Payment:

Payment will not be made for “Preparing Right-of-Way” under this contract. Cost incurred for these items shall be considered subsidiary.

SPECIAL PROVISION

Item 205 Hot Mix Asphaltic Concrete Pavement

Delete:

- **Section 205.5 Measurement in its entirety**
- **Section 205.6 Payment 1st paragraph**
- **Section 205.7 Bid Item in its entirety**

Add:

Section 205.4 Construction G. Placement 7. Acceptable Mat Tolerance

The thickness type used for Type D Asphalt for this Contract shall be 2.0" Compacted depth. Below are acceptable average ranges for 2.0" thick Type D:

Type D, 2.0" Compacted Depth

Shall be applied at 220 LBS/SY

Minimum Average Rate – 210 LBS/SY

Maximum Average Rate – 230 LBS/SY

The thickness type used for Type B Asphalt for this Contract shall be 6.0" or 8.0" Compacted depths. Below are acceptable average ranges for Type B:

Type B, 6.0" Compacted Depth

Shall be applied at 660 LBS/SY

Minimum Average Rate – 630 LBS/SY

Maximum Average Rate – 690 LBS/SY

Type B, 8.0" Compacted Depth

Shall be applied at 880 LBS/SY

Minimum Average Rate – 835 LBS/SY

Maximum Average Rate – 925 LBS/SY

Section 205.5 Measurement:

Hot Mix Asphaltic Concrete Pavement shall be measured by the Ton, complete in place, as per the thickness specified by the plans, Engineer or Project Manager. Limits of payment for Type B will be as indicated on the construction drawings. Limits of payment for Type D will be from face of curb to face of curb. Pavement area shall not exceed the limits shown on the plans without written authorization. In the event the average rate for 2.0" Type D, 6.0" Type B or 8.0" Type B Asphalt falls below the approved ranges as stated in this provision, the newly laid asphalt will not be measured for payment and shall be removed and replaced at the contractor's expense. For situations where the contractor exceeds the maximum average rate

for 2.0" Type D, 6.0" Type B or 8.0" Type B Asphalt, the excess asphalt will not be measured for payment.

Section 205.6 Payment:

The work performed and materials furnished, as described by this item and measured as provided in this provision, shall be paid for at the contract unit bid price per Ton of "Hot Mix Asphaltic Concrete Pavement," which price shall be full compensation for furnishing and placing all materials, and for all labor, tools, equipment and incidentals necessary to complete the work. The prime and tack coat, when required, shall be paid under the provisions of Item Nos. 202 and 203, respectively.

Trial batches will not be paid for unless they are incorporated into pavement work approved by the Engineer or Project Manager.

Pay adjustment for ride quality, when required on the plans, will be determined in accordance with TxDOT Standard Specification Item 585, "Ride Quality for Pavement Surfaces."

As specified in the Measurement section of this provision, if the specified thickness is not achieved and falls below the average acceptable rate, the contractor will not be paid and will be required to remove and replace the entire area that did not fall within the acceptable range at his expense. Once the average rate is satisfactorily met, the contractor will be paid at the contract unit bid price per ton of "Hot Mix Asphaltic Concrete Pavement" for the successful surface course mat.

If the contractor exceeds the maximum average rate as specified in this provision for Type D or B at the depth specified, the amount laid over maximum average rate for the specified thickness will not be paid.

Section 205.7 Bid Item:

Item 205.2 – Hot Mix Asphaltic Pavement, Type B (6.0" Thick) – Per TON

Item 205.2 – Hot Mix Asphaltic Pavement, Type B (8.0" Thick) – Per TON

Item 205.4 – Hot Mix Asphaltic Pavement, Type D (2.0" Thick) – Per TON

SPECIAL PROVISION

ITEM 500 Concrete Curb, Gutter, and Concrete Curb and Gutter

Delete:

- **First paragraph from Section 500.4**
- **Second paragraph from Section 500.4.A.2 Placement**
- **Sixth paragraph from Section 500.4.A.2 Placement**
- **Section 500.6 Payment**
- **Section 500.7 Bid Item**

Add:

Section 500.4 Construction:

Curbs, gutters, curb and gutter combinations, and mountable curb may be placed using conventionally formed concrete placement or using a City approved self-propelled concrete curbing machine.

Section 500.4.A.2 Placement second paragraph:

Place curbs, gutters, combined curb and gutters, and mountable curb in 50 foot maximum sections unless otherwise approved.

Section 500.4.A.2 Placement sixth paragraph:

When finishing operations are completed the curb is to be coated with clear membrane curing compound. Colored membrane curing compound will not be allowed.

Section 500.6 Payment:

The work performed and materials furnished in accordance with this Item and measured as provided under "Measurement" will be paid for at the unit price bid for "Concrete Curb," "Concrete Curb and Gutter," or "Mountable Curb" of the type specified. This price is full compensation for surface preparation of base, equipment, labor, materials, tools, and incidentals necessary to complete the work.

Section 500.7 Bid Item:

Item 500.1 – Concrete Curb – per linear foot (LF)

Item 500.4 – Concrete Curb and Gutter – per linear foot (LF)

Item 500.5 – Mountable Curb – per linear foot (LF)

SPECIAL PROVISION

ITEM 502 Concrete Sidewalks

Delete:

- **Item C Wire Mesh from 502.2 Materials**
- **First paragraph from 502.4.D. Sub-base Placement**
- **First paragraph from 502.4.F. Joints**
- **Item I from 502.4 Construction**
- **502.5 Measurement**
- **First paragraph from 502.6 Payment**

Add:

Section 502.4.D Sub-base Placement:

A cushion, 4 inch minimum thickness, or crusher screenings, gravel, crushed rock or flexible base material shall be spread, wetted thoroughly, tamped and leveled. The cushion shall be moist at the time the concrete is placed. Where the subgrade is rock or gravel, 70% of which is rock, the 4 inch cushion need not be used. The Engineer will determine if the subgrade meets the above requirement.

Section 502.4.E.1 Reinforcement:

6" X 6" W/D 2.9 X W/D 2.9 welded wire flat sheets (Item 303) will NOT be allowed to be used as reinforcement for sidewalks. Contractor shall use No. 3 bars (minimum) @ 18 inches O.C. each way or 6" X 6" W/D 5 X W/D 5 welded wire flat sheets (Item 303) centered in slab as reinforcement for sidewalks.

All curb ramps shall be constructed at commercial grade, with No. 4 bars (minimum) at 12 inches O.C. each way centered in slab, at 6 inches thick. Wheelchair ramps will be paid under item 502.1B Concrete Sidewalks (Commercial Strength). Sub-base placement identified in Section 502.4.D of this provision applies to curb ramps. Wire mesh of any size will NOT be allowed for Item 502.1B Concrete Sidewalks (Commercial Strength).

Section 502.4.F Joints:

Unless otherwise specified on the plans or as agreed to by the Engineer, tooled joints with rounded edges will be placed at intervals equal to the sidewalk width and will be opened with one-half inch (1/2") radius by one and one-half inch (1 1/2") depth and closed by one-half inch (1/2") radius by one-inch (1") depth.

Section 502.4.I Finish and Curing:

Provide finished work with a well-compacted mass, a surface free from voids and honeycomb, and the required true-to-line shape and grade. After finishing each portion of the sidewalk, the surface shall be textured with heavy broom finish. Within twenty minutes of broom finish, a curing compound shall be used to protect the sidewalk. The curing compound shall be of a high solid content, greater than thirty percent (+30%) and be clear in nature. Colored curing compound will not be accepted. All edges shall be tooled to have slight radius. Surface water retention is not acceptable. Finished surface of sidewalks shall generally be one-half inch (½ inch) to one inch (1 inch) above existing grade. Concrete must be cured and protected from freezing temperatures for at least three (3) days. Curing compound must be used during all seasons of the year.

Section 502.5 Measurement:

Sidewalks will be measured by the square yard of surface area at the depth specified. Curb ramps will be measured by the square yard of surface area.

Section 502.6 Payment:

The work performed and materials furnished in accordance with this Item and measured as provided under “Measurement will be paid for at the unit price bid per square yard for “Concrete Sidewalks” or “Concrete Sidewalks (Commercial Strength)” and includes curb ramps where applicable. This price is full compensation for surface preparation of base; materials; excavation, hauling and disposal of excavated material; drilling and doweling into existing concrete curb, sidewalk, and pavement; repair of adjacent street or pavement structure damaged by these operations; and equipment, labor, materials, tools, and incidentals necessary to complete the job.

Section 502.7 Bid Item:

Item 502.1 – Concrete Sidewalks – per square yard (SY)

Item 502.3 – Concrete Sidewalks (Commercial Strength) – per square yard (SY)

SPECIAL PROVISION

Item 503 Asphaltic Concrete, Portland Cement Concrete and Gravel Driveways

Delete:

- **Item N Welded Wire Reinforcement (Item 303) from 503.2 Materials**
- **First paragraph from 503.4.E.5 Portland Cement Concrete Pavement**
- **503.4.E.5.a Commercial Driveways**
- **Item 503.6 Payment**

Add:

Item 503.4.C.1 Flexible Base:

A minimum section of 4" flexible base bedding will be required for installation of all driveways.

Item 503.4.E.5 Portland Cement Concrete Pavement:

If shown on the plans, tie the concrete driveway to concrete pavement or concrete parking lot pavement. Use only drilling operations that do not damage the surrounding operations when drilling holes for replacement steel. Unless otherwise shown on the plans, reinforcement shall consist of No. 3 (3/8") reinforcing steel placed not more than 12 inches on centers both directions. Welded wire flat sheets will not be allowed to be used as reinforcement for residential driveways. If existing reinforcement for residential driveways is greater than No. 3 reinforcing steel, the contractor shall install equal reinforcing steel size. All reinforcement shall be placed equidistant from the top and bottom of the concrete. Care shall be exercised to keep all steel in its proper position during the depositing of concrete. Splices in the No. 3 bars shall have a minimum lap of 12 inches. For existing driveways with existing steel, place new deformed reinforcing steel bars of the same size and spacing as the bars removed or as shown on the plans. Lap all reinforcing steel splices in accordance with Item 301, "Reinforcing Steel." Epoxy-grout all tiebars for at least a 12 inch embedment into existing concrete. Completely fill the tiebar hole with Type III, Class A or Class C epoxy before inserting the tiebar into the hole. Provide grout retention disks for all tiebar holes. Provide and place approved supports to firmly hold the new reinforcing steel, tiebars, and dowel bars in place. The concrete slab for residential driveways shall be a minimum of 5 inches thick or as shown on the plans.

Item 503.4.E.5.a Commercial Driveways:

Reinforcing for commercial driveways shall consist of No. 4 (1/2") reinforcing steel placed not more than 12 inches on center both directions. Welded wire flat sheets will not be allowed to be used as reinforcement for commercial driveways. If existing reinforcement for commercial driveways is greater than No. 4 reinforcing steel, the contractor shall install equal reinforcing steel size. The concrete slab shall be a minimum of 6 inches thick or as shown on the plans. If existing slab thickness is thicker than 6 inches, the contractor shall match the existing thickness for the newly built driveway.

Item 503.6 Payment:

The work performed as prescribed by this item will be paid for at the contract unit price bid per square yard for “Portland Cement Concrete Driveway”, Portland Cement Concrete Driveway – Commercial”, “Asphaltic Concrete Driveway”, or “Gravel Driveway”, which price shall be full compensation for preparing the subgrade, for furnishing and placing all materials, manipulations, labor, tools, equipment and incidentals necessary to complete the work. Payment for reinforcing steel that is greater in size than what is called out for in this specification for residential or commercial driveways will be negotiated between the Contractor and Engineer or Project Manager. Payment for slab thickness greater in size than what is called out for in this specification for residential or commercial driveways will be negotiated between the Contractor and Engineer or Project Manager.

SPECIAL PROVISION

Item 505 Concrete Riprap

Delete:

- **Section 505.4.A Concrete Reinforcement**

Add:

Section 505.4.A Concrete Reinforcement:

Unless otherwise shown on the plans, reinforce concrete riprap with No. 4 reinforcing bars spaced at a maximum of 18 in. in each direction unless otherwise shown. Provide a minimum 6-in. lap at all splices. At the edge of the riprap, provide a minimum horizontal cover of 1 in. and a maximum cover of 3 in. Place the first parallel bar no more than 6 in. from the edge of concrete. Use approved supports to hold the reinforcement approximately equidistant from the top and bottom surface of the slab. Adjust reinforcement during concrete placement to maintain correct position. Reinforcement protruding from existing riprap shall be thoroughly cleaned.

SPECIAL PROVISION

ITEM 513 Removing and Relocating Mailboxes

Delete:

- **Section 513.4 Construction**
- **Section 513.5 Measurement**
- **Section 513.6 Payment**
- **Section 513.7 Bid Item**

Add:

Section 513.4 Construction:

Mail boxes and any supporting posts shall be removed from their present location, installed in a temporary, serviceable location or locations during construction and replaced in a permanent location as shown on the plans. Contractor shall install temporary mailbox for each property during construction so mail delivery is undisturbed. Contractor may use existing mailbox or provide another temporary, secure mailbox for continuous delivery. Any supporting posts found to be set in concrete at the time of their removal shall be reset in the permanent location in concrete. As a minimum, each individual mailbox shall be set on a 4 inch x 4 inch wood post, equal or better than the original, at the location and to the height shown on the plans. Relocate mailbox assemblies at the discretion of the Engineer or Project Manager to permanent locations upon completion of construction work. In the event mailbox is considered unsatisfactory, or out of ADA or US Postal Service requirements, Contractor shall install new mailbox and post as shown in the plans and specifications.

All rock/masonry mailboxes shall be removed from the project site and replaced with the decorative mailbox specified in the plans. Contractor to install decorative mailbox and post combination with style name Gibraltar and Model #PED000B.

Temporary community boxes may be required in lieu of temporarily relocating existing mailboxes. Community boxes will be installed by the US Postal Service on concrete slabs installed by the Contractor as part of this contract. Contractor shall install temporary concrete pads at locations and dimensions as shown on the plans, or as directed by the Engineer, Project Manager, or Inspector. Contractor shall remove concrete slabs upon completion of the project after mail delivery has been switched back to permanent mailboxes. If the contractor chooses to install a community mailbox slab in lieu of providing temporary mailboxes, they shall provide the Engineer or City Project Manager at least one (1) months advanced notice so coordination can be completed with the US Postal Service.

Existing ornamental mailboxes may be reinstalled if they meet ADA and US Postal Service requirements. Contractor shall secure ornamental mailbox to prevent damage during

construction operations. The Engineer or Project Manager will dictate if the existing ornamental mailbox meets requirements or if it shall be replaced.

Maintain mailbox assemblies in a serviceable condition while in their temporary locations. The Contractor is not responsible for damage to the mailbox not of their causing while in the temporary locations. Any damage to the mail boxes, posts, supporting members, braces etc. caused by negligence of the Contractor shall be remedied by the Contractor at his expense. All such repairs shall be made in such a manner so as to insure the unit to be in as good as, or better condition, than it was originally. Any such repairs shall be subject to approval by the Engineer or Project Manager.

Section 513.5 Measurement:

- A. Removing and Relocating Mail Boxes.** "Removing and Relocating Mail Boxes" will be measured by the number of mail boxes so removed and relocated, or replaced.
- B. Community Mailbox Slabs.** Concrete slabs for community mail boxes will be measured by the square yard, complete and in place, to include removal at job completion.
- C. Decorative Mailbox.** Decorative mailboxes will be measured by the number of decorative mailboxes installed. Removal of rock/masonry mailboxes to be measured under Supplemental Specification 4.

Section 513.6 Payment:

- A. Removing and Relocating Mail Boxes.** The work performed as prescribed by this item will be paid for at the contract unit price bid, per mail box, for "Removing and Relocating Mail Boxes" which price shall be full compensation for removing mail boxes from their present position, temporary relocation in a serviceable position, all excavation and excavated material, and relocation or replacement to permanent designated location, for resetting in concrete if required, for furnishing all materials including new mailbox, labor, tools, equipment and incidentals necessary to complete the work.
- B. Community Mailbox Slabs.** Work performed as prescribed by this item will be paid for at the contract unit price bid per square yard for "Community Mailbox Slabs," which price shall be full compensation for the construction and removal of the concrete slab(s), excavation and disposal of virgin material, and materials including reinforcing, labor, tools, equipment and incidentals necessary to complete the work.
- C. Decorative Mailbox.** Work performed as prescribed by this item will be paid for at the contract unit price bid, per decorative mail box installed, which price shall be full compensation for furnishing all materials, installation, for setting on a concrete foundation if required, labor, tools, equipment and incidentals necessary to complete the work. Removal and haul off of existing rock/masonry mailbox to be paid under SUP Item 4.

Section 513.7 Bid Item:

- Item 513.1 – Removing and Relocating Mail Boxes – per Each (EA)
- Item 513.2 – Community Mailbox Slabs – per Square Yard (SY)
- Item 513.3 – Decorative Mailbox (Gibraltar, #PED0000B) – per each (EA)



Item 513.3 – Decorative Mailbox (Gibraltar, #PED000B)

SPECIAL PROVISION

Item 520 Hydromulching

Delete :

- **Section 520.4 Construction (D) Slurry:**
“Annual Ryegrass (Oct. through March 15) 20 lbs per 1,000 sqft”.

Add:

“Annual Ryegrass (Oct. through March 15) 5-10 lbs per 1,000 sqft”.

SPECIAL PROVISION

Item 523 Adjusting of Vehicular & Pedestrian Gates

Delete:

- **Item 523 Adjusting of Vehicular & Pedestrian Gates**

Add:

Section 523.1 Description:

This item shall govern for the adjustment of manual or motorized, chain link or wrought iron, vehicular or pedestrian gates made necessary by the construction of new driveways or sidewalk entrances.

Section 523.2 Materials:

Additional materials needed to perform chain link fences gate adjustments shall conform to those specified in Item 507, "Chain Link Wire Fence". Materials used to adjust wrought iron gates shall be of the same type of material and configuration as the existing gate including any masonry. A combination of new and existing materials may be used if approved by the Engineer and property owner.

Section 523.3 Equipment:

Provide the machinery, tools and equipment necessary for proper prosecution of the work. All machinery, tools and equipment used shall be maintained in a satisfactory and workmanlike manner.

Section 523.4 Construction:

Approval from the property owner and Engineer shall be obtained by the Contractor in order to perform the necessary work required. The Contractor shall adjust gates vertically and or relocated gates horizontally by removing the existing gate from the gate posts and relocating and/or replacing (if necessary) the existing hinges, sliding mechanism, or rollers at a level such that the gate shall be provided with the necessary clearance to operate properly. Contractor shall coordinate extent of adjustments to be made with the property owner and Engineer prior to commencing any gate adjustments. Contractor shall notify property owner or tenant 48 hours in advance of any gate adjustments.

All fabric, posts, braces, gates, fittings, bolts, tension wire, tracks, wheels, rollers, operating mechanism, electrical service, wiring and miscellaneous hardware shall be carefully removed in such a manner that they will not be marred or damaged. After removal of the existing gate has been complete, any material deemed not useable shall be replaced by the Contractor with new material of the same design and quality as the existing material. A new gate constructed of the

same type of material and configuration as the existing gate may be installed if so desired by the Contractor. All fences and gates shall be cut and welded by a qualified welder.

If necessary, the existing fence may be extended, reinforced, or offset in a manner that will not detract from the decorative appeal of the fence. All extensions and offsets of existing fences and gates shall be approved by the property owner.

All gates adjusted vertically shall be extended vertically so that the height of the gate will match existing fence height. Gates that are adjusted vertically shall be provided with a concrete channel for track, gate, sliding mechanism as detailed on plans or as approved by the Engineer and property owner.

All welding will be performed in a workman-like manner with solid joints of minimum protrusion. The adjusted gate will be constructed in such a manner to have minimal flexure.

Any excessive splatter of the weld will be ground off. Existing wrought iron fences and gates will be cleaned and any surface imperfections, any rust and paint will be removed completely. All surfaces of the existing gates will be roughened to accept a new coat of paint. All newly added areas will be completely primed and painted to match existing paint. A second coat will be required to cover any holidays or spots of insufficient coverage. The existing fence and gate will be spot primed in areas where surface imperfections or rust have been removed.

Painting will be by hand or spray. Areas to be painted shall be primed in accordance with paint manufacturer's recommendations. Two coats of paint shall be applied to the existing fence and gate and all newly added parts. The final surface will be of even color without streaks, drips, bubbles, or any other surface imperfection. Paint used shall match existing paint in color and texture. Color shall be approved in writing by the property owner.

Section 523.5 Measurement:

Vehicular and pedestrian gates will be measured for each driveway or sidewalk entrance and/or exit of each type that is adjusted. Additional fencing that may be required for relocation or adjustment of gates will be subsidiary to gate adjustments or gate relocation and will not be measured as a separate pay item.

Section 523.6 Payment:

The work performed and the materials furnished as prescribed by this item will be paid for at the bid price per gate for "Adjusting of Vehicular & Pedestrian Gates," which price shall be full compensation for removing and installing the existing gate and for furnishing all additional materials, all labor, tools, equipment and incidentals necessary to complete the work.

Section 523.7 Bid Item:

Item 523.1 – Adjusting Chain Link Vehicular Gate – Opening

Item 523.3 – Adjusting Chain Link Pedestrian Gate – Each

Item 523.4 – Adjusting Wrought Iron Vehicular Gate – Each

Item 523.6 – Adjusting Wrought Iron Pedestrian Gate – Each

SPECIAL PROVISION

Item 530 Barricades, Signs & Traffic Handling

Delete:

Section 530.5 Measurement in its entirety

Section 530.6 Payment in its entirety

Section 530.7 Bid Item in its entirety

Add:

530.5 Measurement:

Barricades, Signs, & Traffic Handling will not be measured for payment for this contract.

530.6 Payment:

Payment will not be made for “Barricades, Signs & Traffic Handling” under this contract. Cost incurred for these items shall be considered subsidiary.

Reference Supplemental Specification 13 for payment for Portable Changeable Message Signs.

SPECIAL PROVISION

Item 535 Hot Applied Thermoplastic Pavement Markings

For this project, Item 535 “Hot Applied Thermoplastic Pavement Markings” of the Standard Specifications is hereby amended with respect to the clauses cited below, and no other clauses or requirements on the Item are waived or changed hereby.

Add :

Section 535.7 Bid Item:

Item 535.22 – White Sharrow (Bike Shared Lane) – EA, includes one bicycle symbol and two chevrons

Item 535.23 – 12-inch Wide Black Line (Contrast) – per linear foot (LF)

SPECIAL PROVISION

Item 536 Preformed Pavement Markings

For this project, Item 536 “Preformed Pavement Markings” of the Standard Specifications is hereby amended with respect to the clauses cited below, and no other clauses or requirements on the Item are waived or changed hereby.

Article 536.7. Bid Item. The following items are added:

Item 536.22 – 12-inch wide black line (Contrast) – LF

Item 536.23 – 24-inch wide yellow line - LF

SPECIAL PROVISION

Item 540 Temporary Erosion, Sedimentation & Water Pollution Prevention and Control

Delete:

- **Section 540.5 Measurement in its entirety**
- **Section 540.6 Payment in its entirety**
- **Section 540.7 Bid Item in its entirety**

Add:

Section 540.5 Measurement:

It is the contractor's sole responsibility to implement temporary erosion, sedimentation and water pollution prevention and control measures whether it is provided or not. The prevention measures shall prevent soil erosion, sedimentation and water pollution which may degrade receiving water. The Engineer reserves the right to employ outside assistance or to use City forces to provide the necessary corrective measures. All costs including engineering costs will be deducted from any moneys due or to become due to the Contractor.

The following items under Item 540 will be measured for payment under this contract:

- Item 540.1 – Rock Filter Dams (Install/Remove) by the linear foot along the centerline of the top of the dam. Measurement includes installation and removal.
- Item 540.10 – Curb Inlet Gravel Filters by the linear foot, as measured on the centerline of the gravel bags installed.

All other Temporary Erosion, Sedimentation and Water Pollution Prevention and Control measures required for construction completion will not be measured for payment for this contract.

Section 540.6 Payment:

Payment will be made for the following items under Item 540:

- Rock Filter Dams – The work performed and materials furnished in accordance with this Item and measured as provided under "Measurement" will be paid for at the unit price bid as follows:
 - o Installation/Removal – Installation/Removal will be paid for as "Rock Filter Dams (Install/Remove)" of the type specified. This price is full compensation for furnishing and operating equipment, finish backfill and grading, lacing, proper disposal, labor, materials, tools and incidentals necessary to complete the work.
- Curb Inlet Gravel Filters – The work performed and the materials furnished as specified herein, measured as provided under "Measurement" will be paid for at the unit price

bid per linear foot for “Curb Inlet Gravel Filter,” which payment shall be full compensation for furnishing all materials, labor, tools, equipment and incidentals necessary to complete the work as specified, including maintaining and replacing the gravel bags as required by these specifications, removal of accumulated silt, and removal and proper disposal of the “Curb Inlet Gravel Filter” upon completion of site stabilization.

For all other measures under Item 540 required for completion of construction, payment will not be made under this contract. Cost incurred for these items shall be considered subsidiary.

Section 540.7 Bid Item:

Item 540.1A – Rock Filter Dams (Install/Remove) Type 2 – per linear foot (LF)

Item 540.1B – Rock Filter Dams (Sack Gabions) (Install/Remove) Type 4 – per linear foot (LF)

Item 540.10 – Curb Inlet Gravel Filters – per linear foot (LF)

SPECIAL PROVISION

ITEM 556 Cast in Place Detectable Warning Surface Tiles

Delete:

- **Section 556.2B Materials/Color**
- **Section 556.5 Measurement**
- **Section 556.6 Payment**
- **Section 556.7 Bid Item**

Add:

Section 556.2B Materials/Color:

The color of the tile shall be uniform throughout and shall not use any type of paint coating to achieve color stability. The tiles shall contrast visually with adjoining surface by using brick red on light surfaces and yellow on dark surfaces, or gray within historic districts.

Section 556.5 Measurement:

Cast in Place Detectable Warning Surface Tiles will be measured by the unit of each surface tile installed and includes colors of brick red, yellow, or gray.

Section 556.6 Payment:

The work performed as prescribed by this item will be paid for at the contract unit price bid, per Each, for "Cast In Place Detectable Warning Surface Tiles" which price shall be full compensation for furnishing and placing all materials, excavation, manipulation, labor, tools, equipment and incidentals necessary to complete the work.

Section 556.7 Bid Item:

Item 556.1 – Cast In Place Detectable Warning Surface Tile – per each (EA)

SPECIAL PROVISION

Item 851 Adjusting Existing Manholes

Delete:

- **Section 851.5. Payment**

Add:

Section 851.3 Construction:

Contractor shall furnish and install a 5' x 5' x 1" thick steel plate over concrete collars at the discretion of the City inspector or Project Manager until concrete has reached its ultimate strength. Steel plate shall not be removed until concrete collar around the manhole has reached its ultimate strength.

Section 851.4 Measurement:

The furnishing and installation of 5' x 5' x 1" steel plates will not be measured for payment.

Section 851.5 Payment:

The work performed as prescribed by this item will be paid for at the contract unit price bid per manhole for "Adjusting Existing Manholes," which price shall be full compensation for all excavation, including saw cutting of surfaces as required, reinforced concrete and disposal of material excavated, 5' x 5' x 1" thick steel plate; for furnishing and placing all materials and for all labor, tools, equipment and incidentals necessary to complete the work.

SUPPLEMENTAL SPECIFICATION 1

Removing and Relocating Sign

SUP 1.1 DESCRIPTION: Remove and Relocate signs that are in conflict with proposed improvements.

SUP 1.2 MATERIALS: N/A

SUP 1.3 EQUIPMENT: Provide equipment necessary to conduct the work specified herein or as directed by the Engineer.

SUP 1.4 CONSTRUCTION: Perform all work in conformance with this section unless otherwise shown on the plans. Remove and relocate signs in situations where the proposed improvements are in conflict with the sign.

All signs removed shall be relocated directly near the existing location of the sign outside of the proposed improvements, unless direction is given by the Engineer or Project Manager of an alternate location. In situations where there is not sufficient right-of-way to install a sign behind the improvements, the sign must be placed in the proposed sidewalk path and must follow all City and ADA requirements for height clearances and minimum sidewalk widths. Signs that control traffic movement that are removed must be immediately temporarily relocated near the same location to prevent impacting traffic movements. Said signs must be relocated near original location after improvements are in place.

Contractor shall protect all existing signs within the project area. Any sign damage caused by Contractor through his negligence shall be replaced by the Contractor at his sole expense. The Engineer or Project Manager will make the determination if a damaged sign requires replacement.

SUP 1.5 MEASUREMENT: The sign removed and relocated, as prescribed above, will be measured by the unit of each sign. The excavation, concrete and fill necessary to fill the excavated area, if required, will not be measured for payment. Temporary relocation of signs will not be measured for payment.

SUP 1.6 PAYMENT: The work performed as prescribed by this item will be paid for at the contract unit price bid per Each for "Removing and Relocating Sign" which price shall be full compensation for all excavation, disposal of material excavated, temporary relocation of sign, storage and protection of sign removed until relocation takes place; required concrete and fill necessary to fill the area excavated; for furnishing and placing all materials and for all labor, tools, equipment and incidentals necessary to complete the work.

BID ITEM:

SUP 1 – Removing and Relocating Sign – per Each (EA)

SUPPLEMENTAL SPECIFICATION 2

Elevated Sidewalk

SUP 2.1 DESCRIPTION: Construct elevated sidewalk in accordance with the design plans.

SUP 2.2 MATERIALS: Furnish materials conforming to the following:

- A. Hydraulic Cement Concrete:** Item 300, "Concrete." Use Class "C" concrete or other concrete as specified.
- B. Reinforcing Steel:** Item 301, "Reinforcing Steel."
- C. Membrane Curing Compound:** Item 305, "Membrane Curing."
- D. Concrete Structures:** Item 307, "Concrete Structures."

SUP 2.3 EQUIPMENT: Furnish equipment as required and/or in accordance with the pertinent Items.

SUP 2.4 CONSTRUCTION: Location of elevated sidewalk structure shall be indicated by plans or as directed by the Engineer.

- A. Removal of Existing Sidewalk.** If an existing sidewalk is present at the location of the proposed elevated sidewalk, remove existing sidewalk to the depths and limits shown on the plans or identified by the Engineer. All concrete sidewalks to be repaired shall be cut with a concrete saw or other equipment approved by the Engineer from existing sidewalks, driveways, or other concrete structures. If necessary, remove adjacent soil and vegetation to prevent contamination of the sidewalk area, and place it in a windrow or stockpile. Do not damage adjacent sidewalk or other structures during removal and reconstruction operations. Remove and dispose of existing concrete and other materials from the work area.
- B. Subgrade Preparation.** Shape and compact subgrade to the line, grade, and cross-section shown on the plans. Mechanically tamp and sprinkle foundation when placement is directly on subgrade.
- C. Sub-base Placement.** A cushion, 6 inch minimum thickness, of crusher screenings, gravel, crushed rock or flexible base material shall be spread, wetted thoroughly, tamped and leveled. The cushion shall be moist at the time the concrete is placed. Where the subgrade is rock or gravel, 70% of which is rock, the 6 inch cushion need not be used. The Engineer will determine if the subgrade meets the above requirements.

If the subgrade is undercut, or the natural ground is below "top of subgrade," the necessary backfill shall be made with an approved material and compacted with a mechanical tamper. Hand tamping will not be permitted.

The foundation shall be level and uniformly compacted to prevent future settlement.

- D. Reinforcement.** Concrete sidewalks shall be reinforced as shown in the plans. Concrete reinforcement for elevated sidewalks will consist of longitudinal and transverse reinforcing steel as shown on the detail sheet, "Elevated Sidewalk and Retard Standards."
- E. Joints.** Unless otherwise specified on plans or as agreed to by Engineer, tooled joints with rounded edges will be placed every six feet (6') and will be opened with one-half inch ($\frac{1}{2}$ ") radius by one and one-half inch ($1 \frac{1}{2}$ ") depth and closed by one-half inch ($\frac{1}{2}$ ") radius by one-inch (1") depth.
 - 1. Transverse Joints.** Sidewalks shall be marked with transverse "dummy" joints as shown on detail sheets, by the use of City approved jointing tools.
- F. Concrete Placement.** Forms shall be of metal or wood and shall extend for the full depth of the concrete. All forms shall be free from warp and of sufficient strength to resist the pressure of the concrete without displacement. Bracing and staking of forms shall be such that the forms remain in both horizontal and vertical alignment until their removal. All forms shall be cleaned and coated with an approved form release agent or form oil before concrete is placed. Divider plates shall be of metal. Forms shall conform to the specified radius when placed on curves.
- G. Finish and Curing.** Provide finished work with a well-compacted mass, a surface free from voids and honeycomb, and the required true-to-line shape and grade. After finishing each portion of the sidewalk, the surface shall be textured with heavy broom finish. Within twenty minutes of broom finish, a curing compound, clear in color, shall be used to protect the sidewalk. Colored curing compounds will not be allowed. The curing compound shall be of a high solid content, greater than thirty percent (+30%). All edges shall be tooled to have slight radius. Surface water retention is not acceptable. Concrete must be cured and protected from freezing temperatures for at least three (3) days.
- H. Backfilling.** Once elevated sidewalk has cured, sidewalk will need to be backfilled to a height determined by the Engineer with material approved by the Engineer. The top 4 inches of fill shall be tamped and sloped using clean topsoil. Heavy equipment must remain off elevated sidewalk and surrounding sidewalk at all times.

All necessary excavation for the elevated sidewalk section, will be considered incidental work pertaining to this item, and will not be paid for directly. The adjacent excavation and grading of the slopes shall be done in a manner acceptable to the Engineer.

SUP 2.5 MEASUREMENT: Elevated sidewalks will be measured by the linear foot at the depth specified on the Elevated Sidewalk and Retard Standards (Revised) detail sheet. The beams that serve as the foundation of the elevated sidewalk structure, retaining walls, and concrete flooring (6-inch depth) that are associated with the elevated sidewalk, will not be measured for payment directly, but shall be included in the cost of Elevated Sidewalk.

SUP 2.6 PAYMENT: The work performed and materials furnished with this item and measured as provided under “Measurement” will be paid for at the contract unit price bid per Linear Foot for “Elevated Sidewalk” which price shall be full compensation for surface preparation of base; materials; reinforcement; excavation, hauling and disposal of excavated material; drilling and doweling into existing concrete curb, sidewalk and pavement; handrail plates; repair of adjacent street or pavement structure damaged by these operations; and equipment, labor, materials, tools and incidentals necessary to complete the work.

BID ITEM:

SUP 2 – Elevated Sidewalk – per Linear Foot (LF)

SUPPLEMENTAL SPECIFICATION 3

Sidewalk Drain Box

SUP 3.1 DESCRIPTION: Construct sidewalk drain box in accordance with the design plans.

SUP 3.2 MATERIALS: Furnish materials conforming to the following:

- A. Hydraulic Cement Concrete:** Item 300, "Concrete." Use Class "A" concrete or other concrete as specified. Use Grade 8 course aggregate for extruded Class A concrete. Use other grades if approved by the Engineer.
- B. Reinforcing Steel:** Item 301, "Reinforcing Steel."
- C. Membrane Curing Compound:** Item 305, "Membrane Curing."
- D. Concrete Structures:** Item 307, "Concrete Structures."
- E. ½" Thick Galvanized Steel Checkered Plate**

SUP 3.3 EQUIPMENT: Furnish equipment as required and/or in accordance with the pertinent items.

SUP 3.4 CONSTRUCTION: Location of sidewalk drain box shall be indicated by plans or as directed by the Engineer.

- A. Removal of Existing Sidewalk.** If an existing sidewalk is present at the location of the proposed sidewalk drain box, remove existing sidewalk to the depths and limits shown on the plans or identified by the Engineer. All concrete sidewalks to be repaired shall be cut with a concrete saw or other equipment approved by the Engineer from existing sidewalks, driveways, or other concrete structures. If necessary, remove adjacent soil and vegetation to prevent contamination of the sidewalk area, and place it in a windrow or stockpile. Do not damage adjacent sidewalk or other structures during removal and reconstruction operations. Remove and dispose of existing concrete and other materials from the work area.
- B. Subgrade Preparation.** Shape and compact subgrade to the line, grade, and cross-section shown on the plans. Mechanically tamp and sprinkle foundation when placement is directly on subgrade.
- C. Sub-base Placement.** A cushion, 2 inch minimum thickness, of crusher screenings, gravel, crushed rock or flexible base material shall be spread, wetted thoroughly, tamped and leveled. The cushion shall be moist at the time the concrete is placed. Where the subgrade is rock or gravel, 70% of which is rock, the 4 inch cushion need not be used. The Engineer will determine if the subgrade meets the above requirements.

The foundation shall be level and uniformly compacted to prevent future settlement.

- D. Reinforcement.** Concrete sidewalks shall be reinforced as shown in the plans. Concrete reinforcement for the concrete foundation of the sidewalk drain box can be found on the detail sheet titled, "Miscellaneous Construction Standards 1 (Revised)."
- E. Joints.** Unless otherwise specified on plans or as agreed to by Engineer, tooled joints with rounded edges will be placed every six feet (6') and will be opened with one-half inch ($\frac{1}{2}$ ") radius by one and one-half inch ($1 \frac{1}{2}$ ") depth and closed by one-half inch ($\frac{1}{2}$ ") radius by one-inch (1") depth.
- 1. Expansion Joints.** Provide sidewalk sections separated by pre-molded or board joint $\frac{1}{2}$ inch thick or as shown on the plans, on each side of the sidewalk drain unless otherwise directed. The expansion joint material shall be placed vertically and shall extend the full depth and width of the concrete.
- F. Concrete Placement.** Forms shall be of metal or wood and shall extend for the full depth of the concrete. All forms shall be free from warp and of sufficient strength to resist the pressure of the concrete without displacement. Bracing and staking of forms shall be such that the forms remain in both horizontal and vertical alignment until their removal. All forms shall be cleaned and coated with an approved form release agent or form oil before concrete is placed. Divider plates shall be of metal. Forms shall conform to the specified radius when placed on curves.
- G. Finish and Curing.** Provide finished work with a well-compacted mass, a surface free from voids and honeycomb, and the required true-to-line shape and grade. After finishing each portion of the sidewalk, the surface shall be textured with heavy broom finish. Within twenty minutes of broom finish, a curing compound clear in nature shall be used to protect the sidewalk. The curing compound shall be of a high solid content, greater than thirty percent (+30%). All edges shall be tooled to have slight radius. Surface water retention is not acceptable. Concrete must be cured and protected from freezing temperatures for at least three (3) days. Colored curing compound will not be allowed.
- H. Backfilling.** Once concrete has cured, sidewalk will need to be backfilled to a height determined by the Engineer with material approved by the Engineer. The top 4 inches of fill shall be tamped and sloped using clean topsoil. Heavy equipment must remain off sidewalk drain box and surrounding sidewalk at all times.

All necessary excavation for the sidewalk drain box will be considered incidental work pertaining to this item, and will not be paid for directly. The adjacent excavation and grading of the slopes shall be done in a manner acceptable to the Engineer.

SUP 3.5 MEASUREMENT: Sidewalk Drain Box will be measured by each at the width specified on the plans or by the Engineer. The concrete structure that serves as the foundation for the sidewalk drain box shall not be measured for payment, but shall be included in the cost of Sidewalk Drain Box.

SUP 3.6 PAYMENT: The work performed and materials furnished with this item and detail and measured as provided under “Measurement” will be paid for at the contract unit price bid per Each for “Sidewalk Drain Box” which price shall be full compensation for surface preparation of base; materials; reinforcement; excavation, hauling and disposal of excavated material; steel plate; drilling and doweling into existing concrete curb, sidewalk and pavement; repair of adjacent street or pavement structure damaged by these operations; and equipment, labor, materials, tools and incidentals necessary to complete the work. Payment for this item includes up to 15 square feet in surface area for the drain box.

BID ITEM:

SUP 3 – Sidewalk Drain Box – per Each (EA)

SUPPLEMENTAL SPECIFICATION 4

Removal of Existing Rock/Masonry Mailbox

SUP 4.1 DESCRIPTION: Remove and haul off existing rock/masonry mailbox as directed by the Project Manager or City Engineer.

SUP 4.2 MATERIALS: N/A

SUP 4.3 EQUIPMENT: Provide equipment necessary to conduct the work specified herein or as directed by the Engineer.

SUP 4.4 CONSTRUCTION: Perform all work in conformance with this section unless otherwise shown on the plans. Remove and haul off existing rock/masonry mailboxes in situations where the proposed improvements are in conflict with the mailbox.

All rock/masonry mailboxes removed will be replaced with a decorative mailbox in accordance with Special Provision to City Specification 513.1 – Removing and Relocating Mailboxes.

SUP 4.5 MEASUREMENT: The rock/masonry mailbox removed, as prescribed above, will be measured by the unit of each rock/masonry mailbox removed. The excavation and fill necessary to fill the excavated area, if required, will not be measured for payment.

SUP 4.6 PAYMENT: The work performed as prescribed by this item will be paid for at the contract unit price bid per Each for “Removal & Haul Off of Existing Rock/Masonry Mailbox” which price shall be full compensation for all excavation, including saw cutting of surfaces as required, disposal of material excavated; required fill necessary to fill the area excavated; for furnishing and placing all materials and for all labor, tools, equipment and incidentals necessary to complete the work.

BID ITEM:

SUP 4 – Removal of Existing Rock/Masonry Mailbox – per Each (EA)

SUPPLEMENTAL SPECIFICATION 5

Tree Removal

SUP 5.1 DESCRIPTION: Remove trees in conflict with proposed improvements.

SUP 5.2 MATERIALS: Contractor to furnish materials necessary to remove trees.

SUP 5.3 EQUIPMENT: Provide equipment necessary to conduct the work specified herein or as directed by the Engineer.

SUP 5.4 CONSTRUCTION: Perform all work in conformance with this section unless otherwise shown on the plans. Remove trees in situations where the proposed sidewalk and/or curb ramp is in conflict with an existing tree and there is no alternate route to offset the sidewalk or curb ramp around the tree. All tree removals must be approved by the Project Manager and City Arborist. The tree stump shall be removed to a minimum of 18" below ground level. Contractor shall ensure there will be no impacts to existing utilities during tree removal, either above or below ground.

Contractor shall receive a tree maintenance license (TML) issued by Development Services prior to removing any trees under this contract in accordance with city code section 21-171.

SUP 5.5 MEASUREMENT: Tree removals, as prescribed above, will be measured by the unit of each tree removed. The diameter measurement shall be taken at the diameter breast height (dbh) of the tree which is 54 inches above ground level. The excavation and fill necessary to fill the excavated area, if required, will not be measured for payment. Traffic control devices needed for tree removals will also not be measured for payment. Tree removals for trees less than 8" in diameter will not be measured for payment and will be considered part of preparing right of way, which is a subsidiary item. Tree removals for trees greater than 36" in diameter will be negotiated with the Project Manager. Tree maintenance license, application and fees will not be measured for payment.

SUP 5.6 PAYMENT: The work performed as prescribed by this item will be paid for at the contract unit price bid per Each for "Tree Removal" which price shall be full compensation for all excavation, disposal of excavated area and trees removed, required fill necessary to fill the area excavated, traffic control devices, and for furnishing and placing all materials and for all labor, tools, equipment and incidentals necessary to complete work. Extra compensation will not be granted for trees that interfere with aerial utility lines.

BID ITEM:

SUP 5.1 – Tree Removal (8" – 16" diameter) – per Each (EA)

SUP 5.2 – Tree Removal (17" – 24" diameter) – per Each (EA)

SUP 5.3 – Tree Removal (25" – 36" diameter) – per Each (EA)

SUPPLEMENTAL SPECIFICATION 6

Adjusting Traffic Signal Box

SUP 6.1 DESCRIPTION: Adjustment of all impacted existing traffic signal boxes by either lowering or raising the signal box to match the final sidewalk profile grade line.

SUP 6.2 MATERIALS: Contractor to furnish materials necessary to adjust impacted traffic signal box.

SUP 6.3 EQUIPMENT: Provide equipment necessary to conduct the work specified herein or as directed by the Engineer.

SUP 6.4 CONSTRUCTION: Perform all work in conformance with this section unless otherwise shown on the plans. Adjust existing traffic signal box in situations where the finished profile of the sidewalk will be changed from its existing elevation. Contractor shall take all necessary measures to prevent damage to existing signal equipment and box covers from equipment and materials used in or taken through the work area. If an existing or new box and/or cover is/are damaged by the Contractor, it shall be replaced, as directed by the Engineer, by the Contractor at his expense.

The adjusted traffic signal box shall be centered and plumb over the signal equipment. Traffic signal boxes shall be located so that the signal equipment opening is readily accessible for operation through the opening of the signal box.

All signal box covers shall be raised or lowered a sufficient distance so as to be level with the finished surface of the sidewalk.

SUP 6.5 MEASUREMENT: Traffic signal box, as prescribed above, will be measured by the unit of each signal box adjusted. The excavation and fill necessary to fill the excavated area, if required, will not be measured for payment.

SUP 6.6 PAYMENT: The work performed as prescribed by this item will be paid for at the contract unit price bid per Each for "Traffic Signal Box Adjustment" which price shall be full compensation for all excavation, including saw cutting of surfaces as required, disposal of material excavated; required fill necessary to fill the area excavated, if necessary; for furnishing and placing all materials and for all labor, tools, equipment and incidentals necessary to complete the work.

BID ITEM:

SUP 6 – Adjusting Traffic Signal Box – per Each (EA)

SUPPLEMENTAL SPECIFICATION 7

TCI Project Sign

SUP 7.1 DESCRIPTION: Purchase project sign for the Department of Transportation & Capital Improvements (TCI) for length of construction of individual project.

SUP 7.2 MATERIALS: Contractor to furnish materials necessary to display the project sign.

SUP 7.3 EQUIPMENT: Provide equipment necessary to conduct the work specified herein or as directed by the Engineer.

SUP 7.4 CONSTRUCTION: N/A.

SUP 7.5 MEASUREMENT: TCI Project Sign, as prescribed above, will be measured by the unit of each project sign. The storage and transfer of sign from project to project, as well as the equipment & material required to mount the sign, will not be measured for payment. If additional TCI project signs are needed, contractor shall submit written request to project manager for approval.

SUP 7.6 PAYMENT: The work performed as prescribed by this item will be paid for at the contract unit price bid per Each TCI Project Sign which price shall be full compensation for sign purchase, equipment & materials required to mount each sign, storage and transfer of each sign from project to project; for furnishing and placing all materials and for all labor, tools, equipment and incidentals necessary to complete the work

BID ITEM:

SUP 7 – TCI Project Sign – per Each (EA)

SUPPLEMENTAL SPECIFICATION 8

Police Officer

SUP 8.1 DESCRIPTION: Provide uniformed off-duty police officer(s) as directed by the City of San Antonio Project Manager and Traffic Engineer where two-way traffic is to be maintained at major intersections.

SUP 8.2 MATERIALS: N/A

SUP 8.3 CONSTRUCTION: Coordinate with City of San Antonio Construction Inspector to determine the duration and locations where off-duty police officers will be deployed.

SUP 8.4 MEASUREMENT: Police Officer services will be measured by the hour per officer.

SUP 8.5 PAYMENT: The accepted quantity of man-hours shall be paid at the contract unit price per Hour. Contractor to provide time statements for each officer utilized to Inspector. Payment for police officer will be made when hours are verified by the Inspector.

BID ITEM:

SUP 8 – Police Officer – per Hour (HR)

SUPPLEMENTAL SPECIFICATION 9

Removal of Existing Asphalt Speed Hump

SUP 9.1 DESCRIPTION: Remove existing asphalt speed humps in accordance with the design plans.

SUP 9.2 MATERIALS: N/A.

SUP 9.3 EQUIPMENT: Provide equipment necessary to conduct the work specified herein or as directed by the Engineer.

SUP 9.4 CONSTRUCTION: Perform all work in conformance with this section unless otherwise shown on the plans. Remove existing asphalt speed humps as directed by the Engineer. Contractor shall take all necessary measures to prevent damage to existing pavement from equipment and materials used in or taken through the work area. If existing pavement is damaged by the Contractor, it shall be replaced, as directed by the Engineer, by the Contractor at his expense.

SUP 9.5 MEASUREMENT: Removal of Existing Asphalt Speed Hump will be measured by square foot of asphalt speed hump removed.

SUP 9.6 PAYMENT: The work performed and materials furnished with this item and measured as provided under "Measurement" will be paid for at the contract unit price bid per square foot for "Removal of Existing Asphalt Speed Hump" for materials and equipment; excavation, hauling and disposal of excavated material; fill or asphalt required to fill the excavated area; and equipment, labor, materials, tools and incidentals necessary to complete the work.

BID ITEM:

SUP 9 – Removal of Existing Asphalt Speed Hump – per Square Foot (SF)

SUPPLEMENTAL SPECIFICATION 10

Removal of Speed Hump, Type II Modular Rubber Cushion

SUP 10.1 DESCRIPTION: Remove existing rubber speed humps in accordance with the design plans.

SUP 10.2 MATERIALS: N/A.

SUP 10.3 EQUIPMENT: Provide equipment necessary to conduct the work specified herein or as directed by the Engineer.

SUP 10.4 CONSTRUCTION: Perform all work in conformance with this section unless otherwise shown on the plans. Remove existing rubber speed humps as directed by the Engineer. Contractor shall take all necessary measures to prevent damage to existing pavement from equipment and materials used in or taken through the work area. If existing pavement is damaged by the Contractor, it shall be replaced, as directed by the Engineer, by the Contractor at his expense.

SUP 10.5 MEASUREMENT: Removal of Speed Hump, Type II Modular Rubber Cushion will be measured by each unit of rubber speed hump removed.

SUP 10.6 PAYMENT: The work performed and materials furnished with this item and measured as provided under "Measurement" will be paid for at the contract unit price bid per Each for "Removal of Speed Hump, Type II Modular Rubber Cushion" for materials and equipment; excavation, hauling and disposal of excavated material; fill or asphalt required to fill the excavated area; and equipment, labor, materials, tools and incidentals necessary to complete the work.

BID ITEM:

SUP 10 – Removal of Speed Hump, Type II Modular Rubber Cushion – per Each (EA)

SUPPLEMENTAL SPECIFICATION 11

Adjusting Metal Beam Guardrail

SUP 11.1 DESCRIPTION: Adjust metal beam guard rail in accordance with the design plans.

SUP 11.2 MATERIALS: Contractor to furnish materials necessary to adjust metal beam guardrail.

SUP 11.3 EQUIPMENT: Provide equipment necessary to conduct the work specified herein or as directed by the Engineer.

SUP 11.4 CONSTRUCTION: Perform all work in conformance with this section unless otherwise shown on the plans. Adjust metal beam guardrail and timber posts in situations where the proposed improvements are in conflict with the existing metal beam guardrail and/or timber posts. Contractor shall take all necessary measures to prevent damage to existing guardrail and timber posts from equipment and materials used in or taken through the work area. If existing metal beam guardrail or timber post is damaged by the Contractor, it shall be replaced, as directed by the Engineer, by the Contractor at his expense.

If Timber Posts are found to be rotten after they are removed from the ground, the Contractor shall discard of the existing post and install new timber posts in accordance with Item 510 Timber Guard Posts. Disposal of existing timber posts will not be paid for directly, but shall be included in the cost of Adjusting Metal Beam Guardrail. New Timber Guard Posts installed will be paid under Item 510 Timber Guard Posts.

SUP 11.5 MEASUREMENT: Adjusting Metal Beam Guardrail will be measured by linear foot of rail adjusted. Removal and relocation of timber posts shall not be paid for directly, but shall be included in the cost of Adjusting Metal Beam Guardrail.

SUP 11.6 PAYMENT: The work performed and materials furnished with this item and measured as provided under "Measurement" will be paid for at the contract unit price bid per Linear Foot for "Adjusting Metal Beam Guardrail" removal of existing guardrail and timber posts if necessary; relocation or adjustment of existing rail and timber posts; materials; excavation, hauling and disposal of excavated material; fill required to fill the excavated area; and equipment, labor, materials, tools and incidentals necessary to complete the work.

BID ITEM:

SUP 11 – Adjusting Metal Beam Guardrail – per Linear Foot (LF)

SUPPLEMENTAL SPECIFICATION 12

DOOR HANGER

SUP 12.1 DESCRIPTION: Provide door hanger to properties impacted by reconstruction operations.

SUP 12.2 MATERIALS: N/A

SUP 12.3 CONSTRUCTION: The City of San Antonio is to provide template/verbiage for the door hangers. Contractor will be responsible for reproduction of door hanger for each project. Contractor shall place hangers with every business and resident within each segment of the project. For projects that exceed the allotted time specified on the original door hanger, Contractor shall provide updated notice to all residents advising them of the schedule change.

SUP 12.4 MEASUREMENT: Door Hangers will not be measured per each project; rather, it will be based on a one time lump sum measurement for the contract.

SUP 12.5 PAYMENT: Door Hangers shall be paid at the contract unit price per Lump Sum. Payment for additional door hangers required due to construction delays will not be paid for directly, but shall be figured in the Lump Sum cost for door hangers.

BID ITEM:

SUP 12 – Door Hangers – Lump Sum (LS)

SUPPLEMENTAL SPECIFICATION 13

Portable Changeable Message Sign (PCMS) (Electronic Message Board)

SUP 13.1 DESCRIPTION: Provide portable electronic message boards to notify the general public of construction activities for upcoming and ongoing projects.

SUP 13.2 MATERIALS: N/A.

SUP 13.3 EQUIPMENT: Provide equipment necessary to conduct the work specified herein or as directed by the Engineer.

SUP 13.4 CONSTRUCTION: Perform all work in conformance with this section unless otherwise shown on the plans. Provide two (2) portable electronic message boards as directed by Project Manager or Engineer per location. Text for message boards will be provided by Project Manager or Engineer. Not all projects will require portable electronic message boards. Project locations will be determined by the Project Manager or Engineer. Contractor must be able to provide electronic message boards for the duration of specified projects throughout the duration of the contract. Contractor must also have one (1) portable electronic message board on standby in the event one of the message boards in use breaks down.

SUP 13.5 MEASUREMENT: Portable Electronic Message Boards, as prescribed above, will be measured by the month. The equipment required to store, relocate and transport the message boards will not be measured for payment. Adjusting messages will also not be measured for payment. The standby electronic message board will also not be measured for payment.

SUP 13.6 PAYMENT: The work performed as prescribed by this item will be paid for at the contract unit price bid per month for “Portable Electronic Message Boards” which price shall be full compensation for all storage, transportation, set up and maintenance; for furnishing and placing all materials and for all labor, tools, equipment and incidentals necessary to complete the work.

BID ITEM:

SUP 13 – Portable Changeable Message Sign (Electronic Message Board) – per Month

SUPPLEMENTAL SPECIFICATION 14

Additional Mobilization

The City will pay mobilization accordingly for the following situations:

1. For special request projects where the Project Manager requires immediate mobilization (within a 24 to 48-hour period) by the Contractor.
2. For instances where the contractor has mobilized equipment to a specific site, then is asked by the City to relocate equipment to begin a new project without performing any work on the original project.

BID ITEM:

SUP 14 – Mobilization – per Each (EA)

The City will not pay additional mobilization for the following situations. The situations below are considered subsidiary and should be figured into the bid through various other bid items.

1. Mobilization for projects not considered special requests or when the contractor is not redirected as outlined above will not be paid, no matter what the total project cost is.
2. Some projects shall have working time restrictions due to school zones and other factors that may impact a project. The contractor will not be paid extra for projects that have working time restrictions. The extra time on a project required due to a project with time restrictions shall be included in various other bid items.

SUPPLEMENTAL SPECIFICATION 15

Remove & Relocate Customer Shutoff Valve

SUP 15.1 DESCRIPTION: Remove and relocate customer shutoff valve, box and necessary piping out of the sidewalk alignment.

SUP 15.2 MATERIALS: Reference SAWS Specification 824, "Service Supply Lines" for appropriate materials.

SUP 15.3 EQUIPMENT: Provide equipment necessary to conduct the work specified herein or as directed by the Engineer.

SUP15.4 CONSTRUCTION: Reference SAWS Specification 824, "Service Supply Lines" for construction and material specifications. Customer shutoff valves located in the proposed sidewalk alignment shall be relocated directly behind the right of way just inside private property, including valve box. Contractor shall not encase customer shutoff valve and box in concrete; it must be accessible by the property owner. Replace customer shutoff valve with new device and discard existing. Perform all work in conformance with SAWS Specification 824, "Service Supply Lines". Install new plastic valve box if existing box is not sufficient.

SUP 15.5 MEASUREMENT: The customer shutoff valve, as prescribed above, will be measured by the unit of each customer shutoff valve removed and relocated to include a new device of equal or better quality and new plastic valve box. The excavation and fill necessary to fill the excavated area, if required, will not be measured for payment. Additional piping and fittings required for the customer shutoff valve relocation shall not be measured for payment.

SUP 15.6 PAYMENT: The work performed as prescribed by this item will be paid for at the contract unit price bid per Each for "Remove and Relocate Customer Shutoff Valve" which price shall be full compensation for removal and relocation of existing customer shutoff valve and box to include new device of equal or better quality, plastic valve box, piping and fittings required for relocation, excavation, disposal of material excavated; required fill necessary to fill the area excavated; for furnishing and placing all materials and for all labor, tools, equipment and incidentals necessary to complete the work.

BID ITEM:

SUP 15 – Remove & Relocate Customer Shutoff Valve – per Each (EA)

SUPPLEMENTAL SPECIFICATION 16

Remove & Relocate Backflow Preventer

SUP 16.1 DESCRIPTION: Remove and relocate backflow preventer, box and necessary piping out of proposed sidewalk alignment.

SUP 16.2 MATERIALS: Reference Texas Commission on Environmental Quality (TCEQ), Chapter 30, "Occupational Licenses and Registrations" and Chapter 344, "Landscape Irrigation."

SUP 16.3 EQUIPMENT: Provide equipment necessary to conduct the work specified herein or as directed by the Engineer.

SUP 16.4 CONSTRUCTION: Reference TCEQ Chapter 344, "Landscape Irrigation" for construction specifications. Backflow preventers located in the proposed sidewalk alignment shall be relocated directly behind the right of way just inside private property. Contractor shall not encase backflow preventer and box in concrete; it must be accessible by the property owner. Contractor shall evaluate condition of existing backflow preventer prior to removal, and inform the Project Manager if it is unusable. Shall the existing backflow preventer be unusable or not in a working condition, Contractor shall notify property owner and relocate piping for installation of a new backflow preventer by the property owner. Contractor shall not provide a new device. If contractor damages device during relocation process, contractor shall provide a new device of equal or better quality at no additional cost to the City.

SUP 16.5 MEASUREMENT: The backflow preventer, as prescribed above, will be measured by the unit of each backflow preventer removed and relocated. The excavation and fill necessary to fill the excavated area, if required, will not be measured for payment. Additional piping and fittings required for the backflow preventer relocation shall not be measured for payment.

SUP 16.6 PAYMENT: The work performed as prescribed by this item will be paid for at the contract unit price bid per Each for "Remove and Relocate Backflow Preventer" which price shall be full compensation for all removal and relocation of existing backflow preventer and box, new plastic box if required, piping and fittings required for relocation, excavation, disposal of material excavated; required fill necessary to fill the area excavated; for furnishing and placing all materials and for all labor, tools, equipment and incidentals necessary to complete the work.

BID ITEM:

SUP 16 – Remove & Relocate Backflow Preventer – per Each (EA)

SUPPLEMENTAL SPECIFICATION 17

Remove & Relocate Pressure Reducing Valve (PRV)

SUP 17.1 DESCRIPTION: Remove and relocate pressure reducing valve, box and necessary piping out of the sidewalk alignment.

SUP 17.2 MATERIALS: Reference SAWS Specification 833, "Meter and Meter Box Installation" for appropriate materials.

SUP 17.3 EQUIPMENT: Provide equipment necessary to conduct the work specified herein or as directed by the Engineer.

SUP 17.4 CONSTRUCTION: Pressure reducing valve located in the proposed sidewalk alignment shall be relocated directly behind the right of way just inside private property as indicated in SAWS Standard DD-833-03 Service Installation with Pressure Reducing Valve. As part of relocation, contractor shall provide a new pressure reducing valve, with equal or better quality of existing device, and discard of existing. Contractor shall not encase pressure reducing valve and box in concrete; it must be accessible by the property owner. Perform all work in conformance with SAWS Specification 833, "Service Installation with Pressure Reducing Valve". Contractor shall utilize existing box if in good condition, or provide new box as required.

SUP 17.5 MEASUREMENT: The pressure reducing valve, as prescribed above, will be measured by the unit of each pressure reducing valve removed and relocated with a new device and plastic box if required. The excavation and fill necessary to fill the excavated area, if required, will not be measured for payment. Additional piping and fittings required for the pressure reducing valve relocation shall not be measured for payment.

SUP 17.6 PAYMENT: The work performed as prescribed by this item will be paid for at the contract unit price bid per Each for "Remove and Relocate Pressure Reducing Valve" which price shall be full compensation for removal and relocation of existing pressure reducing valve and box, to include new device of equal or better quality, new plastic box if required, piping and fittings required for relocation, excavation, disposal of material excavated; required fill necessary to fill the area excavated; for furnishing and placing all materials and for all labor, tools, equipment and incidentals necessary to complete the work.

BID ITEM:

SUP 17 – Remove & Relocate Pressure Reducing Valve (PRV) – per Each (EA)

ITEM 250
Special Specification

SEAL COAT

250.1 DESCRIPTION:

This item shall consist of a single asphalt surface treatment composed of asphalt surface treatment composed of asphalt material covered with aggregate for the purposed of sealing existing pavements in accordance with these specifications.

250.2 MATERIALS:

A. **AGGREGATE:**

Aggregates shall be of the type as shown on the plans and shall meet all the requirements of the Texas Department of Transportation (TxDOT) Item No. 302, "Aggregate for Surface Treatments" and subsequent revisions thereto. Gradation requirements when tested by TxDOT Test Method Tex-200F, Part I, shall be as shown on the plans.

B. **ASPHALTIC MATERIALS:**

Asphalt cement, emulsified asphalts, other miscellaneous asphaltic materials, and latex additives shall conform to TxDOT Item No. 300, "Asphalt, Oils, and Emulsions" and subsequent revisions thereto.

250.3 EQUIPMENT

A. **DISTRIBUTOR:**

The distributor shall be a self-propelled pressure type, equipped with an asphaltic material heater and a distributing pump capable of pumping the material at the specified rate through the distributor spray bar. The distributor spray bar shall be capable of fully circulating the asphaltic material. The distributor spray bar shall contain nipples and valves so constructed that the nipples will not become partially plugged with congealing asphaltic material, in order to prevent streaking or irregular distribution of asphaltic material. Distributor equipment shall include a tachometer, pressure gauges, volume measuring devices, and thermometer for reading the temperature of tank contents.

The distributor tank shall have been calibrated within three (3) years from the date it is first used on this project. The tank calibration procedure shall be in accordance with Test Method Tex-922-K, Part 1, and shall be signed and sealed by a registered professional engineer. Unless otherwise shown on the plans, the Contractor shall provide the tank calibration and shall furnish the Engineer an accurate and satisfactory calibration record prior to beginning the work. The Engineer may at any time verify calibration accuracy in accordance with Test Method Tex-922-K, Part II, and may perform the recalibration if the calibration is found to be in error.

B. **AGGREGATE SPREADER:**

A self-propelled continuous-feed aggregate spreader shall be used which will uniformly spread aggregate at the rate specified by the Engineer.

C. **ROLLERS:**

Approved rolling equipment shall be of the self-propelled type and shall be so designed such that a 12 ton load may be obtained by ballast loading. The roller shall be equipped with tires that will afford ground contact pressures to 90 psi or more. Individual tire inflation pressures shall be within 5 psi of each other. The operation load and tire air pressure shall be within the range of the manufacture's chart.

D. **SWEEPERS:**

A rotary, self-propelled power broom shall be acceptable for sweeping existing pavement surfaces.

Vacuum sweepers or other approved equally capable equipment shall be suitable for removing loose aggregate from compacted Seal Coat.

250.4 CONSTRUCTION METHOD:

Prior to Seal Coating, all dirt and other objectionable material shall be removed from the existing pavement by sweeping or other approved methods. All existing raised pavement markings shall be removed daily, as the work progresses, and as approved by the Engineer. All vegetation found in the existing pavement shall be destroyed by an approved chemical killer.

Building paper shall be placed over all manholes, valve boxes, grates, etc., so as to protect the surfaces from Asphaltic materials. Asphaltic materials shall not be placed, lapped, or splashed onto adjacent structures.

Seal Coat shall not be applied when the air temperature is below 60°F and is falling, but it may be applied when the air temperature is 50°F and is rising, the air temperature being taken in the shade and away from artificial heat. Seal Coat shall not be applied when the roadway surface temperature is below 60°F or when in the opinion of the Engineer, general weather conditions are not suitable. When latex modified asphalt cement is specified, Seal Coat shall not be applied when the air temperature is below 80°F and is falling, but may be applied when the air temperature is above 70°F and is rising and shall not be applied when the temperature of the surface on which the Seal Coat is to be applied is below 70°F.

Asphalt and aggregate rates as shown on the plans are for estimate purposes only and may be varied as directed by the Engineer.

The width of each application of Asphaltic material shall be such to allow uniform application and immediate covering with aggregate. The contractor shall be responsible for uniform application of asphaltic material at the junction of distributor loads. Paper or other suitable material shall be used to prevent overlapping of transverse joints. Longitudinal joints shall match lane lines unless otherwise authorized by the Engineer. Application of asphaltic material will be measured as necessary to determine the rate of application. In those areas where the asphalt distributor is not accessible, hand spraying may be permitted as directed by the Engineer.

Aggregate shall be immediately and uniformly applied and spread in the same width as the application of asphaltic material. The entire surface shall then be broomed or raked as required by the Engineer.

The aggregate shall be rolled for its width with a minimum of two (2) pneumatic tires rollers which shall be maintained in good repair and operating condition. Rolling shall begin as soon as sufficient aggregate is spread to prevent pick-up and shall begin longitudinally at the outside edge of the mat and progress toward the center of the mat, uniformly lapping each preceding pass by at least 2 the width of the roller. Rolling shall continue until no more aggregate can be worked into the surface.

After all rolling, the finished surface shall be cleared of any surplus aggregate by the Contractor by sweeping. Until the work has been accepted, additional sweeping shall be required as often as necessary so that loose aggregate does not present a hazard to traffic.

The Contractor shall be responsible for the maintenance of the Seal Coat until the work is accepted by the Engineer. All holes or failures in the surface shall be repaired by use of additional asphalt and aggregate. All fat or bleeding surfaces shall be covered with approved cover material in such a manner that the asphaltic material will not adhere to or be picked up by the wheels of vehicles.

All parkways, private property, and driveways adjacent to the work shall be cleaned of loose aggregate and other debris as produced from Seal Coat operations.

250.5 MEASUREMENT:

Seal Coat: will be measured by the square yard of completed and accepted work

250.6 PAYMENT:

The work performed as prescribed by this item will be paid for at the contract unit price bid per square yard for "Seal Coat", which price shall be full compensation for furnishing and placing all materials, sweeping, rolling, manipulations, labor, tools, equipment and incidentals necessary to complete the work.

Payment will be made under:

PAY ITEM NO. 250: SEAL COAT - per square yard.

Item 344

Superpave Mixtures



1. DESCRIPTION

Construct a hot-mix asphalt (HMA) pavement layer composed of a compacted, Superpave (SP) mixture of aggregate and asphalt binder mixed hot in a mixing plant. Payment adjustments will apply to HMA placed under this specification unless the HMA is deemed exempt in accordance with Section 344.4.9.4., "Exempt Production."

2. MATERIALS

Furnish uncontaminated materials of uniform quality that meet the requirements of the plans and specifications.

Notify the Engineer of all material sources and before changing any material source or formulation. The Engineer will verify that the specification requirements are met when the Contractor makes a source or formulation change and may require a new laboratory mixture design, trial batch, or both. The Engineer may sample and test project materials at any time during the project to verify specification compliance in accordance with Item 6, "Control of Materials."

- 2.1. **Aggregate.** Furnish aggregates from sources that conform to the requirements shown in Table 1 and as specified in this Section. Aggregate requirements in this Section, including those shown in Table 1, may be modified or eliminated when shown on the plans. Additional aggregate requirements may be specified when shown on the plans. Provide aggregate stockpiles that meet the definitions in this Section for coarse, intermediate, or fine aggregate. Aggregate from reclaimed asphalt pavement (RAP) is not required to meet Table 1 requirements unless otherwise shown on the plans. Supply aggregates that meet the definitions in [Tex-100-E](#) for crushed gravel or crushed stone. The Engineer will designate the plant or the quarry as the sampling location. Provide samples from materials produced for the project. The Engineer will establish the Surface Aggregate Classification (SAC) and perform Los Angeles abrasion, magnesium sulfate soundness, and Micro-Deval tests. Perform all other aggregate quality tests listed in Table 1. Document all test results on the mixture design report. The Engineer may perform tests on independent or split samples to verify Contractor test results. Stockpile aggregates for each source and type separately. Determine aggregate gradations for mixture design and production testing based on the washed sieve analysis given in [Tex-200-F](#), Part II.

- 2.1.1. **Coarse Aggregate.** Coarse aggregate stockpiles must have no more than 20% material passing the No. 8 sieve. Aggregates from sources listed in the Department's *Bituminous Rated Source Quality Catalog* (BRSQC) are preapproved for use. Use only the rated values for hot-mix listed in the BRSQC. Rated values for surface treatment (ST) do not apply to coarse aggregate sources used in hot-mix asphalt.

For sources not listed on the Department's BRSQC:

- build an individual stockpile for each material;
- request the Department test the stockpile for specification compliance; and
- once approved, do not add material to the stockpile unless otherwise approved.

Provide aggregate from non-listed sources only when tested by the Engineer and approved before use. Allow 30 calendar days for the Engineer to sample, test, and report results for non-listed sources.

Provide coarse aggregate with at least the minimum SAC shown on the plans. SAC requirements only apply to aggregates used on the surface of travel lanes. SAC requirements apply to aggregates used on surfaces

other than travel lanes when shown on the plans. The SAC for sources on the Department's *Aggregate Quality Monitoring Program (AQMP)* ([Tex-499-A](#)) is listed in the BRSQC.

- 2.1.1.1. **Blending Class A and Class B Aggregates.** Class B aggregate meeting all other requirements in Table 1 may be blended with a Class A aggregate to meet requirements for Class A materials. Ensure that at least 50% by weight, or volume if required, of the material retained on the No. 4 sieve comes from the Class A aggregate source when blending Class A and B aggregates to meet a Class A requirement. Blend by volume if the bulk specific gravities of the Class A and B aggregates differ by more than 0.300. Coarse aggregate from RAP and Recycled Asphalt Shingles (RAS) will be considered as Class B aggregate for blending purposes.

The Engineer may perform tests at any time during production, when the Contractor blends Class A and B aggregates to meet a Class A requirement, to ensure that at least 50% by weight, or volume if required, of the material retained on the No. 4 sieve comes from the Class A aggregate source. The Engineer will use the Department's mix design template, when electing to verify conformance, to calculate the percent of Class A aggregate retained on the No. 4 sieve by inputting the bin percentages shown from readouts in the control room at the time of production and stockpile gradations measured at the time of production. The Engineer may determine the gradations based on either washed or dry sieve analysis from samples obtained from individual aggregate cold feed bins or aggregate stockpiles. The Engineer may perform spot checks using the gradations supplied by the Contractor on the mixture design report as an input for the template; however, a failing spot check will require confirmation with a stockpile gradation determined by the Engineer.

- 2.1.1.2. **Micro-Deval Abrasion.** The Engineer will perform a minimum of one Micro-Deval abrasion test in accordance with [Tex-461-A](#) for each coarse aggregate source used in the mixture design that has a Rated Source Soundness Magnesium (RSSM) loss value greater than 15 as listed in the BRSQC. The Engineer will perform testing before the start of production and may perform additional testing at any time during production. The Engineer may obtain the coarse aggregate samples from each coarse aggregate source or may require the Contractor to obtain the samples. The Engineer may waive all Micro-Deval testing based on a satisfactory test history of the same aggregate source.

The Engineer will estimate the magnesium sulfate soundness loss for each coarse aggregate source, when tested, using the following formula:

$$Mg_{est.} = (RSSM)(MD_{act.}/RSMD)$$

where:

$Mg_{est.}$ = magnesium sulfate soundness loss

$MD_{act.}$ = actual Micro-Deval percent loss

$RSMD$ = Rated Source Micro-Deval

When the estimated magnesium sulfate soundness loss is greater than the maximum magnesium sulfate soundness loss specified, the coarse aggregate source will not be allowed for use unless otherwise approved. The Engineer will consult the Geotechnical, Soils, and Aggregates Branch of the Construction Division, and additional testing may be required before granting approval.

- 2.1.2. **Intermediate Aggregate.** Aggregates not meeting the definition of coarse or fine aggregate will be defined as intermediate aggregate. Supply intermediate aggregates, when used that are free from organic impurities. The Engineer may test the intermediate aggregate in accordance with [Tex-408-A](#) to verify the material is free from organic impurities. Supply intermediate aggregate from coarse aggregate sources, when used that meet the requirements shown in Table 1 unless otherwise approved.

Test the stockpile if 10% or more of the stockpile is retained on the No. 4 sieve, and verify that it meets the requirements in Table 1 for crushed face count ([Tex-460-A](#)) and flat and elongated particles ([Tex-280-F](#)).

- 2.1.3. **Fine Aggregate.** Fine aggregates consist of manufactured sands, screenings, and field sands. Fine aggregate stockpiles must meet the gradation requirements in Table 2. Supply fine aggregates that are free from organic impurities. The Engineer may test the fine aggregate in accordance with [Tex-408-A](#) to verify the

material is free from organic impurities. No more than 15% of the total aggregate may be field sand or other uncrushed fine aggregate. Use fine aggregate, with the exception of field sand, from coarse aggregate sources that meet the requirements shown in Table 1 unless otherwise approved.

Test the stockpile if 10% or more of the stockpile is retained on the No. 4 sieve and verify that it meets the requirements in Table 1 for crushed face count (Tex-460-A) and flat and elongated particles (Tex-280-F).

Table 1
Aggregate Quality Requirements

Property	Test Method	Requirement
Coarse Aggregate		
SAC	Tex-499-A (AQMP)	As shown on the plans
Deleterious material, %, Max	Tex-217-F , Part I	1.0
Decantation, %, Max	Tex-217-F , Part II	1.5
Micro-Deval abrasion, %	Tex-461-A	Note 1
Los Angeles abrasion, %, Max	Tex-410-A	35
Magnesium sulfate soundness, 5 cycles, %, Max	Tex-411-A	25
Crushed face count, ² %, Min	Tex-460-A , Part I	85
Flat and elongated particles @ 5:1, %, Max	Tex-280-F	10
Fine Aggregate		
Linear shrinkage, %, Max	Tex-107-E	3
Combined Aggregate³		
Sand equivalent, %, Min	Tex-203-F	45

- Used to estimate the magnesium sulfate soundness loss in accordance with Section 344.2.1.1.2., "Micro-Deval Abrasion."
- Only applies to crushed gravel.
- Aggregates, without mineral filler, RAP, RAS, or additives, combined as used in the job-mix formula (JMF).

Table 2
Gradation Requirements for Fine Aggregate

Sieve Size	% Passing by Weight or Volume
3/8"	100
#8	70–100
#200	0–30

- 2.2. **Mineral Filler.** Mineral filler consists of finely divided mineral matter such as agricultural lime, crusher fines, hydrated lime, or fly ash. Mineral filler is allowed unless otherwise shown on the plans. Use no more than 2% hydrated lime or fly ash unless otherwise shown on the plans. Use no more than 1% hydrated lime if a substitute binder is used unless otherwise shown on the plans or allowed. Test all mineral fillers except hydrated lime and fly ash in accordance with [Tex-107-E](#) to ensure specification compliance. The plans may require or disallow specific mineral fillers. Provide mineral filler, when used, that:

- is sufficiently dry, free-flowing, and free from clumps and foreign matter as determined by the Engineer;
- does not exceed 3% linear shrinkage when tested in accordance with [Tex-107-E](#); and
- meets the gradation requirements in Table 3.

Table 3
Gradation Requirements for Mineral Filler

Sieve Size	% Passing by Weight or Volume
#8	100
#200	55–100

- 2.3. **Baghouse Fines.** Fines collected by the baghouse or other dust-collecting equipment may be reintroduced into the mixing drum.
- 2.4. **Asphalt Binder.** Furnish the type and grade of performance-graded (PG) asphalt specified on the plans.
- 2.5. **Tack Coat.** Furnish CSS-1H, SS-1H, or a PG binder with a minimum high-temperature grade of PG 58 for tack coat binder in accordance with Item 300, "Asphalts, Oils, and Emulsions." Specialized or preferred tack coat materials may be allowed or required when shown on the plans. Do not dilute emulsified asphalts at the terminal, in the field, or at any other location before use.

The Engineer will obtain at least one sample of the tack coat binder per project in accordance with [Tex-500-C](#), Part III, and test it to verify compliance with Item 300, "Asphalts, Oils, and Emulsions." The Engineer will obtain the sample from the asphalt distributor immediately before use.

- 2.6. **Additives.** Use the type and rate of additive specified when shown on the plans. Additives that facilitate mixing, compaction, or improve the quality of the mixture are allowed when approved. Provide the Engineer with documentation such as the bill of lading showing the quantity of additives used in the project unless otherwise directed.
- 2.6.1. **Lime and Liquid Antistripping Agent.** When lime or a liquid antistripping agent is used, add in accordance with Item 301, "Asphalt Antistripping Agents." Do not add lime directly into the mixing drum of any plant where lime is removed through the exhaust stream unless the plant has a baghouse or dust collection system that reintroduces the lime into the drum.
- 2.6.2. **Warm Mix Asphalt (WMA).** Warm Mix Asphalt (WMA) is defined as HMA that is produced within a target temperature discharge range of 215°F and 275°F using approved WMA additives or processes from the Department's MPL.

WMA is allowed for use on all projects and is required when shown on the plans. When WMA is required, the maximum placement or target discharge temperature for WMA will be set at a value below 275°F.

Department-approved WMA additives or processes may be used to facilitate mixing and compaction of HMA produced at target discharge temperatures above 275°F; however, such mixtures will not be defined as WMA.

- 2.7. **Recycled Materials.** Use of RAP and RAS is permitted unless otherwise shown on the plans. Do not exceed the maximum allowable percentages of RAP and RAS shown in Table 4. The allowable percentages shown in Table 4 may be decreased or increased when shown on the plans. Determine asphalt binder content and gradation of the RAP and RAS stockpiles for mixture design purposes in accordance with [Tex-236-F](#). The Engineer may verify the asphalt binder content of the stockpiles at any time during production. Perform other tests on RAP and RAS when shown on the plans. Asphalt binder from RAP and RAS is designated as recycled asphalt binder. Calculate and ensure that the ratio of the recycled asphalt binder to total binder does not exceed the percentages shown in Table 5 during mixture design and HMA production when RAP or RAS is used. Use a separate cold feed bin for each stockpile of RAP and RAS during HMA production.

Surface, intermediate, and base mixes referenced in Tables 4 and 5 are defined as follows:

- **Surface.** The final HMA lift placed at or near the top of the pavement structure;
- **Intermediate.** Mixtures placed below an HMA surface mix and less than or equal to 8.0 in. from the riding surface; and
- **Base.** Mixtures placed greater than 8.0 in. from the riding surface.

- 2.7.1. **RAP.** RAP is salvaged, milled, pulverized, broken, or crushed asphalt pavement. Crush or break RAP so that 100% of the particles pass the 2 in. sieve. Fractionated RAP is defined as 2 or more RAP stockpiles, divided into coarse and fine fractions.

Use of Contractor-owned RAP including HMA plant waste is permitted unless otherwise shown on the plans. Department-owned RAP stockpiles are available for the Contractor's use when the stockpile locations are shown on the plans. If Department-owned RAP is available for the Contractor's use, the Contractor may use Contractor-owned fractionated RAP and replace it with an equal quantity of Department-owned RAP. This allowance does not apply to a Contractor using unfractionated RAP. Department-owned RAP generated through required work on the Contract is available for the Contractor's use when shown on the plans. Perform any necessary tests to ensure Contractor- or Department-owned RAP is appropriate for use. The Department will not perform any tests or assume any liability for the quality of the Department-owned RAP unless otherwise shown on the plans. The Contractor will retain ownership of RAP generated on the project when shown on the plans.

The coarse RAP stockpile will contain only material retained by processing over a 3/8-in. or 1/2-in. screen unless otherwise approved. The fine RAP stockpile will contain only material passing the 3/8-in. or 1/2-in. screen unless otherwise approved. The Engineer may allow the Contractor to use an alternate to the 3/8-in. or 1/2-in. screen to fractionate the RAP. The maximum percentages of fractionated RAP may be comprised of coarse or fine fractionated RAP or the combination of both coarse and fine fractionated RAP.

Do not use Department- or Contractor-owned RAP contaminated with dirt or other objectionable materials. Do not use Department- or Contractor-owned RAP if the decantation value exceeds 5% and the plasticity index is greater than 8. Test the stockpiled RAP for decantation in accordance with [Tex-406-A](#), Part I. Determine the plasticity index in accordance with [Tex-106-E](#) if the decantation value exceeds 5%. The decantation and plasticity index requirements do not apply to RAP samples with asphalt removed by extraction or ignition.

Do not intermingle Contractor-owned RAP stockpiles with Department-owned RAP stockpiles. Remove unused Contractor-owned RAP material from the project site upon completion of the project. Return unused Department-owned RAP to the designated stockpile location.

Table 4
Maximum Allowable Amounts of RAP¹

Maximum Allowable Fractionated RAP ² (%)			Maximum Allowable Unfractionated RAP ³ (%)		
Surface	Intermediate	Base	Surface	Intermediate	Base
20.0	25.0	30.0	10.0	10.0	10.0

1. Must also meet the recycled binder to total binder ratio shown in Table 5.
2. Up to 5% RAS may be used separately or as a replacement for fractionated RAP.
3. Unfractionated RAP may not be combined with fractionated RAP or RAS.

2.7.2.

RAS. Use of post-manufactured RAS or post-consumer RAS (tear-offs) is permitted unless otherwise shown on the plans. Up to 5% RAS may be used separately or as a replacement for fractionated RAP in accordance with Table 4 and Table 5. RAS is defined as processed asphalt shingle material from manufacturing of asphalt roofing shingles or from re-roofing residential structures. Post-manufactured RAS is processed manufacturer's shingle scrap by-product. Post-consumer RAS is processed shingle scrap removed from residential structures. Comply with all regulatory requirements stipulated for RAS by the TCEQ. RAS may be used separately or in conjunction with RAP.

Process the RAS by ambient grinding or granulating such that 100% of the particles pass the 3/8 in. sieve when tested in accordance with [Tex-200-F](#), Part I. Perform a sieve analysis on processed RAS material before extraction (or ignition) of the asphalt binder.

Add sand meeting the requirements of Table 1 and Table 2 or fine RAP to RAS stockpiles if needed to keep the processed material workable. Any stockpile that contains RAS will be considered a RAS stockpile and be limited to no more than 5.0% of the HMA mixture in accordance with Table 4.

Certify compliance of the RAS with [DMS-11000](#), "Evaluating and Using Nonhazardous Recyclable Materials Guidelines." Treat RAS as an established nonhazardous recyclable material if it has not come into contact with any hazardous materials. Use RAS from shingle sources on the Department's MPL. Remove substantially all materials before use that are not part of the shingle, such as wood, paper, metal, plastic, and felt paper. Determine the deleterious content of RAS material for mixture design purposes in accordance with [Tex-217-F](#), Part III. Do not use RAS if deleterious materials are more than 0.5% of the stockpiled RAS unless otherwise approved. Submit a sample for approval before submitting the mixture design. The Department will perform the testing for deleterious material of RAS to determine specification compliance.

2.8.

Substitute Binders. Unless otherwise shown on the plans, the Contractor may use a substitute PG binder listed in Table 5 instead of the PG binder originally specified, if the substitute PG binder and mixture made with the substitute PG binder meet the following:

- the substitute binder meets the specification requirements for the substitute binder grade in accordance with Section 300.2.10., "Performance-Graded Binders;" and

- the mixture has less than 10.0 mm of rutting on the Hamburg Wheel test ([Tex-242-F](#)) after the number of passes required for the originally specified binder. Use of substitute PG binders may only be allowed at the discretion of the Engineer if the Hamburg Wheel test results are between 10.0 mm and 12.5 mm.

Table 5
Allowable Substitute PG Binders and Maximum Recycled Binder Ratios

Originally Specified PG Binder	Allowable Substitute PG Binder	Maximum Ratio of Recycled Binder ¹ to Total Binder (%)		
		Surface	Intermediate	Base
HMA				
76-22 ²	70-22 or 64-22	20.0	20.0	20.0
	70-28 or 64-28	30.0	35.0	40.0
70-22 ²	64-22	20.0	20.0	20.0
	64-28 or 58-28	30.0	35.0	40.0
64-22 ²	58-28	30.0	35.0	40.0
76-28 ²	70-28 or 64-28	20.0	20.0	20.0
	64-34	30.0	35.0	40.0
70-28 ²	64-28 or 58-28	20.0	20.0	20.0
	64-34 or 58-34	30.0	35.0	40.0
64-28 ²	58-28	20.0	20.0	20.0
	58-34	30.0	35.0	40.0
WMA³				
76-22 ²	70-22 or 64-22	30.0	35.0	40.0
70-22 ²	64-22 or 58-28	30.0	35.0	40.0
64-22 ⁴	58-28	30.0	35.0	40.0
76-28 ²	70-28 or 64-28	30.0	35.0	40.0
70-28 ²	64-28 or 58-28	30.0	35.0	40.0
64-28 ⁴	58-28	30.0	35.0	40.0

1. Combined recycled binder from RAP and RAS.
2. Use no more than 20.0% recycled binder when using this originally specified PG binder.
3. WMA as defined in Section 344.2.6.2., "Warm Mix Asphalt (WMA)."
4. When used with WMA, this originally specified PG binder is allowed for use at the maximum recycled binder ratios shown in this table.

3. EQUIPMENT

Provide required or necessary equipment in accordance with Item 320, "Equipment for Asphalt Concrete Pavement."

4. CONSTRUCTION

Produce, haul, place, and compact the specified paving mixture. In addition to tests required by the specification, Contractors may perform other QC tests as deemed necessary. At any time during the project, the Engineer may perform production and placement tests as deemed necessary in accordance with Item 5, "Control of the Work." Schedule and participate in a mandatory pre-paving meeting with the Engineer on or before the first day of paving unless otherwise shown on the plans.

- 4.1. **Certification.** Personnel certified by the Department-approved hot-mix asphalt certification program must conduct all mixture designs, sampling, and testing in accordance with Table 6. Supply the Engineer with a list of certified personnel and copies of their current certificates before beginning production and when personnel changes are made. Provide a mixture design developed and signed by a Level 2 certified specialist. Provide Level 1A certified specialists at the plant during production operations. Provide Level 1B certified specialists to conduct placement tests.

Table 6
Test Methods, Test Responsibility, and Minimum Certification Levels

Test Description	Test Method	Contractor	Engineer	Level ¹
1. Aggregate and Recycled Material Testing				
Sampling	Tex-221-F	✓	✓	1A
Dry sieve	Tex-200-F , Part I	✓	✓	1A
Washed sieve	Tex-200-F , Part II	✓	✓	1A
Deleterious material	Tex-217-F , Parts I & III	✓	✓	1A
Decantation	Tex-217-F , Part II	✓	✓	1A
Los Angeles abrasion	Tex-410-A		✓	TxDOT
Magnesium sulfate soundness	Tex-411-A		✓	TxDOT
Micro-Deval abrasion	Tex-461-A		✓	2
Crushed face count	Tex-460-A	✓	✓	2
Flat and elongated particles	Tex-280-F	✓	✓	2
Linear shrinkage	Tex-107-E	✓	✓	2
Sand equivalent	Tex-203-F	✓	✓	2
Organic impurities	Tex-408-A	✓	✓	2
2. Asphalt Binder & Tack Coat Sampling				
Asphalt binder sampling	Tex-500-C , Part II	✓	✓	1A/1B
Tack coat sampling	Tex-500-C , Part III	✓	✓	1A/1B
3. Mix Design & Verification				
Design and JMF changes	Tex-204-F	✓	✓	2
Mixing	Tex-205-F	✓	✓	2
Molding (SGC)	Tex-241-F	✓	✓	1A
Laboratory-molded density	Tex-207-F	✓	✓	1A
VMA ² (calculation only)	Tex-204-F	✓	✓	2
Rice gravity	Tex-227-F	✓	✓	1A
Ignition oven correction factors ³	Tex-236-F	✓	✓	2
Indirect tensile strength	Tex-226-F	✓	✓	2
Hamburg Wheel test	Tex-242-F	✓	✓	2
Boil test	Tex-530-C	✓	✓	1A
4. Production Testing				
Selecting production random numbers	Tex-225-F , Part I		✓	1A
Mixture sampling	Tex-222-F	✓	✓	1A
Molding (SGC)	Tex-241-F	✓	✓	1A
Laboratory-molded density	Tex-207-F	✓	✓	1A
VMA ² (calculation only)	Tex-204-F	✓	✓	1A
Rice gravity	Tex-227-F	✓	✓	1A
Gradation & asphalt binder content ³	Tex-236-F	✓	✓	1A
Control charts	Tex-233-F	✓	✓	1A
Moisture content	Tex-212-F	✓	✓	1A
Hamburg Wheel test	Tex-242-F	✓	✓	2
Micro-Deval abrasion	Tex-461-A		✓	2
Boil test	Tex-530-C	✓	✓	1A
Abson recovery	Tex-211-F		✓	TxDOT
Overlay test	Tex-248-F		✓	TxDOT
Cantabro loss	Tex-245-F		✓	2
5. Placement Testing				
Selecting placement random numbers	Tex-225-F , Part II		✓	1A/1B
Trimming roadway cores	Tex-207-F	✓	✓	1A/1B
In-place air voids	Tex-207-F	✓	✓	1A/1B
Establish rolling pattern	Tex-207-F	✓		1B
Control charts	Tex-233-F	✓	✓	1A
Ride quality measurement	Tex-1001-S	✓	✓	Note 4
Segregation (density profile)	Tex-207-F , Part V	✓	✓	1B
Longitudinal joint density	Tex-207-F , Part VII	✓	✓	1B
Thermal profile	Tex-244-F	✓	✓	1B

- Level 1A, 1B, and 2 are certification levels provided by the Hot Mix Asphalt Center certification program.
- Void in mineral aggregates.
- Refer to Section 344.4.9.2.3., "Production Testing," for exceptions to using an ignition oven.
- Profiler and operator are required to be certified at the Texas A&M Transportation Institute facility when Surface Test Type B is specified.

4.2.

Reporting and Responsibilities. Use Department-provided templates to record and calculate all test data, including mixture design, production and placement QC/QA, control charts, thermal profiles, segregation density profiles, and longitudinal joint density. Obtain the current version of the templates at <http://www.txdot.gov/inside-txdot/forms-publications/consultants-contractors/forms/site-manager.html> or from the Engineer. The Engineer and the Contractor will provide any available test results to the other party when requested. The maximum allowable time for the Contractor and Engineer to exchange test data is as given in Table 7 unless otherwise approved. The Engineer and the Contractor will immediately report to the other party any test result that requires suspension of production or placement, a payment adjustment less than 1,000, or that fails to meet the specification requirements. Record and electronically submit all test results and pertinent information on Department-provided templates.

Subsequent sublots placed after test results are available to the Contractor, which require suspension of operations, may be considered unauthorized work. Unauthorized work will be accepted or rejected at the discretion of the Engineer in accordance with Article 5.3., "Conformity with Plans, Specifications, and Special Provisions."

Table 7
Reporting Schedule

Description	Reported By	Reported To	To Be Reported Within
Production Quality Control			
Gradation ¹	Contractor	Engineer	1 working day of completion of the subplot
Asphalt binder content ¹			
Laboratory-molded density ²			
Moisture content ³			
Boil test ³			
Production Quality Assurance			
Gradation ³	Engineer	Contractor	1 working day of completion of the subplot
Asphalt binder content ³			
Laboratory-molded density ¹			
Hamburg Wheel test ²			
Boil test ³			
Binder tests ²			
Placement Quality Control			
In-place air voids ²	Contractor	Engineer	1 working day of completion of the lot
Segregation ¹			
Longitudinal joint density ¹			
Thermal profile ¹			
Placement Quality Assurance			
In-place air voids ¹	Engineer	Contractor	1 working day of receipt of the trimmed cores for in-place air voids ⁴
Segregation ²			
Longitudinal joint density ²			
Thermal profile ²			
Aging ratio ²			
Payment adjustment summary	Engineer	Contractor	2 working days of performing all required tests and receiving Contractor test data

1. These tests are required on every subplot.
2. Optional test. To be reported as soon as results become available.
3. To be performed at the frequency specified on the plans.
4. 2 days are allowed if cores cannot be dried to constant weight within 1 day.

The Engineer will use the Department-provided template to calculate all payment adjustment factors for the lot. Sublot samples may be discarded after the Engineer and Contractor sign off on the payment adjustment summary documentation for the lot.

Use the procedures described in [Tex-233-F](#) to plot the results of all quality control (QC) and quality assurance (QA) testing. Update the control charts as soon as test results for each subplot become available. Make the control charts readily accessible at the field laboratory. The Engineer may suspend production for failure to update control charts.

- 4.3. **Quality Control Plan (QCP).** Develop and follow the QCP in detail. Obtain approval for changes to the QCP made during the project. The Engineer may suspend operations if the Contractor fails to comply with the QCP.
- Submit a written QCP before the mandatory pre-paving meeting. Receive approval of the QCP before beginning production. Include the following items in the QCP.
- 4.3.1. **Project Personnel.** For project personnel, include:
- a list of individuals responsible for QC with authority to take corrective action;
 - current contact information for each individual listed; and
 - current copies of certification documents for individuals performing specified QC functions.
- 4.3.2. **Material Delivery and Storage.** For material delivery and storage, include:
- the sequence of material processing, delivery, and minimum quantities to assure continuous plant operations;
 - aggregate stockpiling procedures to avoid contamination and segregation;
 - frequency, type, and timing of aggregate stockpile testing to assure conformance of material requirements before mixture production; and
 - procedure for monitoring the quality and variability of asphalt binder.
- 4.3.3. **Production.** For production, include:
- loader operation procedures to avoid contamination in cold bins;
 - procedures for calibrating and controlling cold feeds;
 - procedures to eliminate debris or oversized material;
 - procedures for adding and verifying rates of each applicable mixture component (e.g., aggregate, asphalt binder, RAP, RAS, lime, liquid antistriper, WMA);
 - procedures for reporting job control test results; and
 - procedures to avoid segregation and drain-down in the silo.
- 4.3.4. **Loading and Transporting.** For loading and transporting, include:
- type and application method for release agents; and
 - truck loading procedures to avoid segregation.
- 4.3.5. **Placement and Compaction.** For placement and compaction, include:
- proposed agenda for mandatory pre-paving meeting, including date and location;
 - proposed paving plan (e.g., paving widths, joint offsets, and lift thicknesses);
 - type and application method for release agents in the paver and on rollers, shovels, lutes, and other utensils;
 - procedures for the transfer of mixture into the paver, while avoiding segregation and preventing material spillage;
 - process to balance production, delivery, paving, and compaction to achieve continuous placement operations and good ride quality;
 - paver operations (e.g., operation of wings, height of mixture in auger chamber) to avoid physical and thermal segregation and other surface irregularities; and
 - procedures to construct quality longitudinal and transverse joints.
- 4.4. **Mixture Design.**
- 4.4.1. **Design Requirements.** Use the SP design procedure provided in [Tex-204-F](#), unless otherwise shown on the plans. Design the mixture to meet the requirements listed in Tables 1, 2, 3, 4, 5, 8, 9, 10, and 11.

Design the mixture at 50 gyrations (N_{design}). Use a target laboratory-molded density of 96.0% to design the mixture; however, adjustments can be made to the N_{design} value as noted in Table 10. The N_{design} level may be reduced to no less than 35 gyrations at the Contractor's discretion.

Use an approved laboratory from the Department's MPL to perform the Hamburg Wheel test and provide results with the mixture design, or provide the laboratory mixture and request that the Department perform the Hamburg Wheel test. The Engineer will be allowed 10 working days to provide the Contractor with Hamburg Wheel test results on the laboratory mixture design.

The Engineer will provide the mixture design when shown on the plans. The Contractor may submit a new mixture design at any time during the project. The Engineer will verify and approve all mixture designs (JMF1) before the Contractor can begin production.

The aggregate gradation may pass above, below, or through the reference zone shown in Table 9 unless otherwise shown on the plans. Design a mixture with a gradation that has stone-on-stone contact and passes below the reference zone shown in Table 9 when shown on the plans. Verify stone-on-stone contact using the method given in the SP design procedure in [Tex-204-F](#), Part IV.

Provide the Engineer with a mixture design report using the Department-provided template. Include the following items in the report:

- the combined aggregate gradation, source, specific gravity, and percent of each material used;
- asphalt binder content and aggregate gradation of RAP and RAS stockpiles;
- the N_{design} level used;
- results of all applicable tests;
- the mixing and molding temperatures;
- the signature of the Level 2 person or persons that performed the design;
- the date the mixture design was performed; and
- a unique identification number for the mixture design.

Table 8
Master Gradation Limits (% Passing by Weight or Volume) and VMA Requirements

Sieve Size	SP-A Base	SP-B Intermediate	SP-C Surface	SP-D Fine Mixture
2"	100.0 ¹	–	–	–
1-1/2"	98.0–100.0	100.0 ¹	–	–
1"	90.0–100.0	98.0–100.0	100.0 ¹	–
3/4"	Note 2	90.0–100.0	98.0–100.0	100.0 ¹
1/2"	–	Note 2	90.0–100.0	98.0–100.0
3/8"	–	–	Note 2	90.0–100.0
#4	19.0–90.0	23.0–90.0	28.0–90.0	32.0–90.0
#8	19.0–45.0	23.0–49.0	28.0–58.0	32.0–67.0
#16	1.0–45.0	2.0–49.0	2.0–58.0	2.0–67.0
#30	1.0–45.0	2.0–49.0	2.0–58.0	2.0–67.0
#50	1.0–45.0	2.0–49.0	2.0–58.0	2.0–67.0
#200	1.0–7.0	2.0–8.0	2.0–10.0	2.0–10.0
Design VMA, % Minimum				
	13.0	14.0	15.0	16.0
Production (Plant-Produced) VMA, % Minimum				
	12.5	13.5	14.5	15.5

1. Defined as maximum sieve size. No tolerance allowed.

2. Must retain at least 10% cumulative.

Table 9
Reference Zones (% Passing by Weight or Volume)

Sieve Size	SP-A Base	SP-B Intermediate	SP-C Surface	SP-D Fine Mixture
2"	–	–	–	–
1-1/2"	–	–	–	–
1"	–	–	–	–
3/4"	–	–	–	–
1/2"	–	–	–	–
3/8"	–	–	–	–
#4	39.5–39.5	–	–	–
#8	26.8–30.8	34.6–34.6	39.1–39.1	47.2–47.2
#16	18.1–24.1	22.3–28.3	25.6–31.6	31.6–37.6
#30	13.6–17.5	16.7–20.7	19.1–23.1	23.5–27.5
#50	11.4–11.4	13.7–13.7	15.5–15.5	18.7–18.7
#200	–	–	–	–

Table 10
Laboratory Mixture Design Properties

Mixture Property	Test Method	Requirement
Target laboratory-molded density, %	Tex-207-F	96.0
Design gyrations (N _{design})	Tex-241-F	50 ¹
Indirect tensile strength (dry), psi	Tex-226-F	85–200 ²
Dust/asphalt binder ratio ³	–	0.6–1.6
Boil test ⁴	Tex-530-C	–

1. Adjust within a range of 35–100 gyrations when shown on the plans or specification or mutually agreed between the Engineer and Contractor.
2. The Engineer may allow the IDT strength to exceed 200 psi if the corresponding Hamburg Wheel rut depth is greater than 3.0 mm and less than 12.5 mm.
3. Defined as % passing #200 sieve divided by asphalt binder content.
4. Used to establish baseline for comparison to production results. May be waived when approved.

Table 11
Hamburg Wheel Test Requirements

High-Temperature Binder Grade	Test Method	Minimum # of Passes @ 12.5 mm ¹ Rut Depth, Tested @ 50°C
PG 64 or lower	Tex-242-F	10,000 ²
PG 70		15,000 ³
PG 76 or higher		20,000

1. When the rut depth at the required minimum number of passes is less than 3 mm, the Engineer may require the Contractor to lower the N_{design} level to no less than 35 gyrations.
2. May be decreased to no less than 5,000 passes when shown on the plans.
3. May be decreased to no less than 10,000 passes when shown on the plans.

4.4.2. **Job-Mix Formula Approval.** The job-mix formula (JMF) is the combined aggregate gradation, N_{design} level, and target asphalt percentage used to establish target values for hot-mix production. JMF1 is the original laboratory mixture design used to produce the trial batch. When WMA is used, JMF1 may be designed and submitted to the Engineer without including the WMA additive. When WMA is used, document the additive or process used and recommended rate on the JMF1 submittal. The Engineer and the Contractor will verify JMF1 based on plant-produced mixture from the trial batch unless otherwise approved. The Engineer may accept an existing mixture design previously used on a Department project and may waive the trial batch to verify JMF1. The Department may require the Contractor to reimburse the Department for verification tests if more than 2 trial batches per design are required.

4.4.2.1. **Contractor's Responsibilities.**

4.4.2.1.1. **Providing Superpave Gyrotory Compactor (SGC).** Furnish an SGC calibrated in accordance with [Tex-241-F](#) for molding production samples. Locate the SGC at the Engineer's field laboratory and make the SGC available to the Engineer for use in molding production samples.

- 4.4.2.1.2. **Gyratory Compactor Correlation Factors.** Use [Tex-206-F](#), Part II, to perform a gyratory compactor correlation when the Engineer uses a different SGC. Apply the correlation factor to all subsequent production test results.
- 4.4.2.1.3. **Submitting JMF1.** Furnish a mix design report (JMF1) with representative samples of all component materials and request approval to produce the trial batch. Provide approximately 10,000 g of the design mixture if opting to have the Department perform the Hamburg Wheel test on the laboratory mixture, and request that the Department perform the test.
- 4.4.2.1.4. **Supplying Aggregates.** Provide approximately 40 lb. of each aggregate stockpile unless otherwise directed.
- 4.4.2.1.5. **Supplying Asphalt.** Provide at least 1 gal. of the asphalt material and sufficient quantities of any additives proposed for use.
- 4.4.2.1.6. **Ignition Oven Correction Factors.** Determine the aggregate and asphalt correction factors from the ignition oven in accordance with [Tex-236-F](#). Provide the Engineer with split samples of the mixtures before the trial batch production, including all additives (except water), and blank samples used to determine the correction factors for the ignition oven used for QA testing during production. Correction factors established from a previously approved mixture design may be used for the current mixture design if the mixture design and ignition oven are the same as previously used, unless otherwise directed.
- 4.4.2.1.7. **Boil Test.** Perform the test and retain the tested sample from [Tex-530-C](#) until completion of the project or as directed. Use this sample for comparison purposes during production. The Engineer may waive the requirement for the boil test.
- 4.4.2.1.8. **Trial Batch Production.** Provide a plant-produced trial batch upon receiving conditional approval of JMF1 and authorization to produce a trial batch, including the WMA additive or process if applicable, for verification testing of JMF1 and development of JMF2. Produce a trial batch mixture that meets the requirements in Table 4, Table 5, and Table 12. The Engineer may accept test results from recent production of the same mixture instead of a new trial batch.
- 4.4.2.1.9. **Trial Batch Production Equipment.** Use only equipment and materials proposed for use on the project to produce the trial batch.
- 4.4.2.1.10. **Trial Batch Quantity.** Produce enough quantity of the trial batch to ensure that the mixture meets the specification requirements.
- 4.4.2.1.11. **Number of Trial Batches.** Produce trial batches as necessary to obtain a mixture that meets the specification requirements.
- 4.4.2.1.12. **Trial Batch Sampling.** Obtain a representative sample of the trial batch and split it into 3 equal portions in accordance with [Tex-222-F](#). Label these portions as "Contractor," "Engineer," and "Referee." Deliver samples to the appropriate laboratory as directed.
- 4.4.2.1.13. **Trial Batch Testing.** Test the trial batch to ensure the mixture produced using the proposed JMF1 meets the mixture requirements in Table 12. Ensure the trial batch mixture is also in compliance with the Hamburg Wheel-requirement in Table 11. Use a Department-approved laboratory to perform the Hamburg Wheel test on the trial batch mixture or request that the Department perform the Hamburg Wheel test.
- The Engineer will be allowed 10 working days to provide the Contractor with Hamburg Wheel test results on the trial batch. Provide the Engineer with a copy of the trial batch test results.
- 4.4.2.1.14. **Development of JMF2.** Evaluate the trial batch test results after the Engineer grants full approval of JMF1 based on results from the trial batch, determine the optimum mixture proportions, and submit as JMF2. Adjust the asphalt binder content or gradation to achieve the specified target laboratory-molded density. The asphalt binder content established for JMF2 is not required to be within any tolerance of the optimum asphalt binder content established for JMF1; however, mixture produced using JMF2 must meet the voids in mineral

aggregates (VMA) requirements for production shown in Table 8. If the optimum asphalt binder content for JMF2 is more than 0.5% lower than the optimum asphalt binder content for JMF1, the Engineer may perform or require the Contractor to perform [Tex-226-F](#) on Lot 1 production to confirm the indirect tensile strength does not exceed 200 psi. Verify that JMF2 meets the mixture requirements in Table 4 and Table 5.

- 4.4.2.1.15. **Mixture Production.** Use JMF2 to produce Lot 1 as described in Section 344.4.9.3.1.1., “Lot 1 Placement,” after receiving approval for JMF2 and a passing result from the Department’s or a Department-approved laboratory’s Hamburg Wheel test on the trial batch. If desired, proceed to Lot 1 production, once JMF2 is approved, at the Contractor’s risk without receiving the results from the Department’s Hamburg Wheel test on the trial batch.

Notify the Engineer if electing to proceed without Hamburg Wheel test results from the trial batch. Note that the Engineer may require up to the entire subplot of any mixture failing the Hamburg Wheel test to be removed and replaced at the Contractor’s expense.

- 4.4.2.1.16. **Development of JMF3.** Evaluate the test results from Lot 1, determine the optimum mixture proportions, and submit as JMF3 for use in Lot 2.

- 4.4.2.1.17. **JMF Adjustments.** If JMF adjustments are necessary to achieve the specified requirements, make the adjustment before beginning a new lot. The adjusted JMF must:

- be provided to the Engineer in writing before the start of a new lot;
- be numbered in sequence to the previous JMF;
- meet the mixture requirements in Table 4 and Table 5;
- meet the master gradation limits shown in Table 8; and
- be within the operational tolerances of JMF2 listed in Table 12.

- 4.4.2.1.18. **Requesting Referee Testing.** Use referee testing, if needed, in accordance with Section 344.4.9.1., “Referee Testing,” to resolve testing differences with the Engineer.

**Table 12
Operational Tolerances**

Description	Test Method	Allowable Difference Between Trial Batch and JMF1 Target	Allowable Difference from Current JMF Target	Allowable Difference between Contractor and Engineer ¹
Individual % retained for #8 sieve and larger	Tex-200-F or Tex-236-F	Must be Within Master Grading Limits in Table 8	±5.0 ^{2,3}	±5.0
Individual % retained for sieves smaller than #8 and larger than #200			±3.0 ^{2,3}	±3.0
% passing the #200 sieve			±2.0 ^{2,3}	±1.6
Asphalt binder content, %	Tex-236-F	±0.5	±0.3 ³	±0.3
Laboratory-molded density, %	Tex-207-F	±1.0	±1.0	±0.5
In-place air voids, %		N/A	N/A	±1.0
Laboratory-molded bulk specific gravity		N/A	N/A	±0.020
VMA, % Min	Tex-204-F	Note 4	Note 4	N/A
Theoretical maximum specific (Rice) gravity	Tex-227-F	N/A	N/A	±0.020

1. Contractor may request referee testing only when values exceed these tolerances.
2. When within these tolerances, mixture production gradations may fall outside the master grading limits; however, the % passing the #200 will be considered out of tolerance when outside the master grading limits.
3. Only applies to mixture produced for Lot 1 and higher.
4. Test and verify that Table 8 requirements are met.

- 4.4.2.2. **Engineer’s Responsibilities.**

- 4.4.2.2.1. **Gyratory Compactor.** The Engineer will use a Department SGC, calibrated in accordance with [Tex-241-F](#), to mold samples for laboratory mixture design verification. For molding trial batch and production specimens, the Engineer will use the Contractor-provided SGC at the field laboratory or provide and use a Department

SGC at an alternate location. The Engineer will make the Contractor-provided SGC in the Department field laboratory available to the Contractor for molding verification samples.

4.4.2.2.2. **Conditional Approval of JMF1 and Authorizing Trial Batch.** The Engineer will review and verify conformance of the following information within 2 working days of receipt:

- the Contractor's mix design report (JMF1);
- the Contractor-provided Hamburg Wheel test results;
- all required materials including aggregates, asphalt, additives, and recycled materials; and
- the mixture specifications.

The Engineer will grant the Contractor conditional approval of JMF1 if the information provided on the paper copy of JMF1 indicates that the Contractor's mixture design meets the specifications. When the Contractor does not provide Hamburg Wheel test results with laboratory mixture design, 10 working days are allowed for conditional approval of JMF1. The Engineer will base full approval of JMF1 on the test results on mixture from the trial batch.

Unless waived, the Engineer will determine the Micro-Deval abrasion loss in accordance with Section 344.2.1.1.2., "Micro-Deval Abrasion." If the Engineer's test results are pending after 2 working days, conditional approval of JMF1 will still be granted within 2 working days of receiving JMF1. When the Engineer's test results become available, they will be used for specification compliance.

After conditionally approving JMF1, including either Contractor- or Department-supplied Hamburg Wheel test results, the Contractor is authorized to produce a trial batch.

4.4.2.2.3. **Hamburg Wheel Testing of JMF1.** If the Contractor requests the option to have the Department perform the Hamburg Wheel test on the laboratory mixture, the Engineer will mold samples in accordance with [Tex-242-F](#) to verify compliance with the Hamburg Wheel test requirement in Table 11.

4.4.2.2.4. **Ignition Oven Correction Factors.** The Engineer will use the split samples provided by the Contractor to determine the aggregate and asphalt correction factors for the ignition oven used for QA testing during production in accordance with [Tex-236-F](#).

4.4.2.2.5. **Testing the Trial Batch.** Within 1 full working day, the Engineer will sample and test the trial batch to ensure that the mixture meets the requirements in Table 12. If the Contractor requests the option to have the Department perform the Hamburg Wheel test on the trial batch mixture, the Engineer will mold samples in accordance with [Tex-242-F](#) to verify compliance with the Hamburg Wheel test requirement in Table 11.

The Engineer will have the option to perform the following tests on the trial batch:

- [Tex-226-F](#), to verify that the indirect tensile strength meets the requirement shown in Table 10; and
- [Tex-530-C](#), to retain and use for comparison purposes during production.

4.4.2.2.6. **Full Approval of JMF1.** The Engineer will grant full approval of JMF1 and authorize the Contractor to proceed with developing JMF2 if the Engineer's results for the trial batch meet the requirements in Table 12. The Engineer will notify the Contractor that an additional trial batch is required if the trial batch does not meet these requirements.

4.4.2.2.7. **Approval of JMF2.** The Engineer will approve JMF2 within one working day if the mixture meets the requirements in Table 5 and the gradation meets the master grading limits shown in Table 8. The asphalt binder content established for JMF2 is not required to be within any tolerance of the optimum asphalt binder content established for JMF1; however, mixture produced using JMF2 must meet the VMA requirements shown in Table 8. If the optimum asphalt binder content for JMF2 is more than 0.5% lower than the optimum asphalt binder content for JMF1, the Engineer may perform or require the Contractor to perform [Tex-226-F](#) on Lot 1 production to confirm the indirect tensile strength does not exceed 200 psi.

4.4.2.2.8. **Approval of Lot 1 Production.** The Engineer will authorize the Contractor to proceed with Lot 1 production (using JMF2) as soon as a passing result is achieved from the Department's or a Department-approved

laboratory's Hamburg Wheel test on the trial batch. The Contractor may proceed at its own risk with Lot 1 production without the results from the Hamburg Wheel test on the trial batch.

If the Department's or Department-approved laboratory's sample from the trial batch fails the Hamburg Wheel test, the Engineer will suspend production until further Hamburg Wheel tests meet the specified values. The Engineer may require up to the entire subplot of any mixture failing the Hamburg Wheel test be removed and replaced at the Contractor's expense.

- 4.4.2.2.9. **Approval of JMF3 and Subsequent JMF Changes.** JMF3 and subsequent JMF changes are approved if they meet the mixture requirements shown in Table 4, Table 5, and the master grading limits shown in Table 8, and are within the operational tolerances of JMF2 shown in Table 12.
- 4.5. **Production Operations.** Perform a new trial batch when the plant or plant location is changed. Take corrective action and receive approval to proceed after any production suspension for noncompliance to the specification. Submit a new mix design and perform a new trial batch when the asphalt binder content of:
- any RAP stockpile used in the mix is more than 0.5% higher than the value shown on the mixture design report; or
 - RAS stockpile used in the mix is more than 2.0% higher than the value shown on the mixture design report.
- 4.5.1. **Storage and Heating of Materials.** Do not heat the asphalt binder above the temperatures specified in Item 300, "Asphalts, Oils, and Emulsions," or outside the manufacturer's recommended values. Provide the Engineer with daily records of asphalt binder and hot-mix asphalt discharge temperatures (in legible and discernible increments) in accordance with Item 320, "Equipment for Asphalt Concrete Pavement," unless otherwise directed. Do not store mixture for a period long enough to affect the quality of the mixture, nor in any case longer than 12 hr. unless otherwise approved.
- 4.5.2. **Mixing and Discharge of Materials.** Notify the Engineer of the target discharge temperature and produce the mixture within 25°F of the target. Monitor the temperature of the material in the truck before shipping to ensure that it does not exceed 350°F (or 275°F for WMA) and is not lower than 215°F. The Department will not pay for or allow placement of any mixture produced above 350°F.
- Produce WMA within the target discharge temperature range of 215°F and 275°F when WMA is required. Take corrective action any time the discharge temperature of the WMA exceeds the target discharge range. The Engineer may suspend production operations if the Contractor's corrective action is not successful at controlling the production temperature within the target discharge range. Note that when WMA is produced, it may be necessary to adjust burners to ensure complete combustion such that no burner fuel residue remains in the mixture.
- Control the mixing time and temperature so that substantially all moisture is removed from the mixture before discharging from the plant. Determine the moisture content, if requested, by oven-drying in accordance with [Tex-212-F](#), Part II, and verify that the mixture contains no more than 0.2% of moisture by weight. Obtain the sample immediately after discharging the mixture into the truck, and perform the test promptly.
- 4.6. **Hauling Operations.** Clean all truck beds before use to ensure that mixture is not contaminated. Use a release agent shown on the Department's MPL to coat the inside bed of the truck when necessary.
- Use equipment for hauling as defined in Section 344.4.7.3.3., "Hauling Equipment." Use other hauling equipment only when allowed.
- 4.7. **Placement Operations.** Collect haul tickets from each load of mixture delivered to the project and provide the Department's copy to the Engineer approximately every hour or as directed. Use a hand-held thermal camera or infrared thermometer, when a thermal imaging system is not used, to measure and record the internal temperature of the mixture as discharged from the truck or Material Transfer Device (MTD) before or as the mix enters the paver and an approximate station number or GPS coordinates on each ticket. Calculate the daily yield and cumulative yield for the specified lift and provide to the Engineer at the end of paving

operations for each day unless otherwise directed. The Engineer may suspend production if the Contractor fails to produce and provide haul tickets and yield calculations by the end of paving operations for each day.

Prepare the surface by removing raised pavement markers and objectionable material such as moisture, dirt, sand, leaves, and other loose impediments from the surface before placing mixture. Remove vegetation from pavement edges. Place the mixture to meet the typical section requirements and produce a smooth, finished surface with a uniform appearance and texture. Offset longitudinal joints of successive courses of hot-mix by at least 6 in. Place mixture so that longitudinal joints on the surface course coincide with lane lines, or as directed. Ensure that all finished surfaces will drain properly. Place the mixture at the rate or thickness shown on the plans. The Engineer will use the guidelines in Table 13 to determine the compacted lift thickness of each layer when multiple lifts are required. The thickness determined is based on the rate of 110 lb./sq. yd. for each inch of pavement unless otherwise shown on the plans.

Table 13
Compacted Lift Thickness and Required Core Height

Mixture Type	Compacted Lift Thickness Guidelines		Minimum Untrimmed Core Height (in.) Eligible for Testing
	Minimum (in.)	Maximum (in.)	
SP-A	3.00	5.0	2.50
SP-B	2.25	4.0	2.00
SP-C	1.50	3.0	1.25
SP-D	1.25	2.0	1.25

4.7.1. **Weather Conditions.**

4.7.1.1. **When Using a Thermal Imaging System.** The Contractor may pave any time the roadway is dry and the roadway surface temperature is at least 32°F; however, the Engineer may restrict the Contractor from paving surface mixtures if the ambient temperature is likely to drop below 32°F within 12 hr. of paving. Provide output data from the thermal imaging system to demonstrate to the Engineer that no recurring severe thermal segregation exists in accordance with Section 344.4.7.3.1.2., “Thermal Imaging System.”

4.7.1.2. **When Not Using a Thermal Imaging System.** Place mixture when the roadway surface temperature is at or above the temperatures listed in Table 14 unless otherwise approved or as shown on the plans. Measure the roadway surface temperature with a hand-held thermal camera or infrared thermometer. The Engineer may allow mixture placement to begin before the roadway surface reaches the required temperature if conditions are such that the roadway surface will reach the required temperature within 2 hr. of beginning placement operations. Place mixtures only when weather conditions and moisture conditions of the roadway surface are suitable as determined by the Engineer. The Engineer may restrict the Contractor from paving if the ambient temperature is likely to drop below 32°F within 12 hr. of paving.

Table 14
Minimum Pavement Surface Temperatures

Originally Specified High Temperature Binder Grade	Minimum Pavement Surface Temperatures (°F)	
	Subsurface Layers or Night Paving Operations	Surface Layers Placed in Daylight Operations
PG 64 or lower	45	50
PG 70	55 ¹	60 ¹
PG 76 or higher	60 ¹	60 ¹

- Contractors may pave at temperatures 10°F lower than these values when utilizing a paving process including WMA or equipment that eliminates thermal segregation. In such cases, use a hand-held thermal camera operated in accordance with [Tex-244-F](#) to demonstrate to the satisfaction of the Engineer that the uncompacted mat has no more than 10°F of thermal segregation.

4.7.2. **Tack Coat.** Clean the surface before placing the tack coat. The Engineer will set the rate between 0.04 and 0.10 gal. of residual asphalt per square yard of surface area. Apply a uniform tack coat at the specified rate unless otherwise directed. Apply the tack coat in a uniform manner to avoid streaks and other irregular patterns. Apply a thin, uniform tack coat to all contact surfaces of curbs, structures, and all joints. Allow adequate time for emulsion to break completely before placing any material. Prevent splattering of tack coat when placed adjacent to curb, gutter, and structures. Roll the tack coat with a pneumatic-tire roller to remove streaks and other irregular patterns when directed.

- 4.7.3. **Lay-Down Operations.**
- 4.7.3.1. **Thermal Profile.** Use a hand-held thermal camera or a thermal imaging system to obtain a continuous thermal profile in accordance with [Tex-244-F](#). Thermal profiles are not applicable in areas described in Section 344.4.9.3.1.4., "Miscellaneous Areas."
- 4.7.3.1.1. **Thermal Segregation.**
- 4.7.3.1.1.1. **Moderate.** Any areas that have a temperature differential greater than 25°F, but not exceeding 50°F, are deemed as having moderate thermal segregation.
- 4.7.3.1.1.2. **Severe.** Any areas that have a temperature differential greater than 50°F are deemed as having severe thermal segregation.
- 4.7.3.1.2. **Thermal Imaging System.** Review the output results when a thermal imaging system is used, and provide the automated report described in [Tex-244-F](#) to the Engineer daily unless otherwise directed. Modify the paving process as necessary to eliminate any recurring (moderate or severe) thermal segregation identified by the thermal imaging system. The Engineer may suspend paving operations if the Contractor cannot successfully modify the paving process to eliminate recurring severe thermal segregation. Density profiles are not required and not applicable when using a thermal imaging system. Provide the Engineer with electronic copies of all daily data files that can be used with the thermal imaging system software to generate temperature profile plots upon completion of the project or as requested by the Engineer.
- 4.7.3.1.3. **Thermal Camera.** Take immediate corrective action to eliminate recurring moderate thermal segregation when a hand-held thermal camera is used. Evaluate areas with moderate thermal segregation by performing density profiles in accordance with Section 344.4.9.3.3.2., "Segregation (Density Profile)." Provide the Engineer with the thermal profile of every subplot within one working day of the completion of each lot. Report the results of each thermal profile in accordance with Section 344.4.2., "Reporting and Responsibilities." The Engineer will use a hand-held thermal camera to obtain a thermal profile at least once per project. No production or placement payment adjustments greater than 1.000 will be paid for any subplot that contains severe thermal segregation. Suspend operations and take immediate corrective action to eliminate severe thermal segregation unless otherwise directed. Resume operations when the Engineer determines that subsequent production will meet the requirements of this Section. Evaluate areas with severe thermal segregation by performing density profiles in accordance with Section 344.4.9.3.3.2., "Segregation (Density Profile)." Remove and replace the material in any areas that have both severe thermal segregation and a failing result for Segregation (Density Profile) unless otherwise directed. The subplot in question may receive a production and placement payment adjustment greater than 1.000, if applicable, when the defective material is successfully removed and replaced.
- 4.7.3.2. **Windrow Operations.** Operate windrow pickup equipment so that when hot-mix is placed in windrows, substantially all the mixture deposited on the roadbed is picked up and loaded into the paver.
- 4.7.3.3. **Hauling Equipment.** Use belly dumps, live bottom, or end dump trucks to haul and transfer mixture; however, with exception of paving miscellaneous areas, end dump trucks are only allowed when used in conjunction with an MTD with remixing capability or when a thermal imaging system is used unless otherwise allowed.
- 4.7.3.4. **Screed Heaters.** Turn off screed heaters to prevent overheating of the mat if the paver stops for more than 5 min. The Engineer may evaluate the suspect area in accordance with Section 344.4.9.3.3.4., "Recovered Asphalt Dynamic Shear Rheometer (DSR)," if the screed heater remains on for more than 5 min. while the paver is stopped.
- 4.8. **Compaction.** Compact the pavement uniformly to contain between 3.7% and 7.5% in-place air voids. Take immediate corrective action to bring the operation within 3.7% and 7.5% when the in-place air voids exceed the range of these tolerances. The Engineer will allow paving to resume when the proposed corrective action is likely to yield between 3.7% and 7.5% in-place air voids.

Obtain cores in areas placed under Exempt Production, as directed, at locations determined by the Engineer. The Engineer may test these cores and suspend operations or require removal and replacement if the in-place air voids are less than 2.7% or more than 9.0%. Areas defined in Section 344.4.9.3.1.4., "Miscellaneous Areas," are not subject to in-place air void determination.

Furnish the type, size, and number of rollers required for compaction as approved. Use a pneumatic-tire roller to seal the surface unless excessive pickup of fines occurs. Use additional rollers as required to remove any roller marks. Use only water or an approved release agent on rollers, tamps, and other compaction equipment unless otherwise directed.

Use the control strip method shown in [Tex-207-E](#), Part IV, on the first day of production to establish the rolling pattern that will produce the desired in-place air voids unless otherwise directed.

Use tamps to thoroughly compact the edges of the pavement along curbs, headers, and similar structures and in locations that will not allow thorough compaction with rollers. The Engineer may require rolling with a trench roller on widened areas, in trenches, and in other limited areas.

Complete all compaction operations before the pavement temperature drops below 160°F unless otherwise allowed. The Engineer may allow compaction with a light finish roller operated in static mode for pavement temperatures below 160°F.

Allow the compacted pavement to cool to 160°F or lower before opening to traffic unless otherwise directed. Sprinkle the finished mat with water or limewater, when directed, to expedite opening the roadway to traffic.

- 4.9. **Acceptance Plan.** Payment adjustments for the material will be in accordance with Article 344.6., "Payment."

Sample and test the hot-mix on a lot and subplot basis. Suspend production until test results or other information indicates to the satisfaction of the Engineer that the next material produced or placed will result in pay factors of at least 1.000 if the production pay factor given in Section 344.6.1., "Production Payment Adjustment Factors," for 2 consecutive lots or the placement pay factor given in Section 344.6.2., "Placement Payment Adjustment Factors," for 2 consecutive lots is below 1.000.

- 4.9.1. **Referee Testing.** The Construction Division is the referee laboratory. The Contractor may request referee testing if a "remove and replace" condition is determined based on the Engineer's test results, or if the differences between Contractor and Engineer test results exceed the maximum allowable difference shown in Table 12 and the differences cannot be resolved. The Contractor may also request referee testing if the Engineer's test results require suspension of production and the Contractor's test results are within specification limits. Make the request within 5 working days after receiving test results and cores from the Engineer. Referee tests will be performed only on the subplot in question and only for the particular tests in question. Allow 10 working days from the time the referee laboratory receives the samples for test results to be reported. The Department may require the Contractor to reimburse the Department for referee tests if more than 3 referee tests per project are required and the Engineer's test results are closer to the referee test results than the Contractor's test results.

The Construction Division will determine the laboratory-molded density based on the molded specific gravity and the maximum theoretical specific gravity of the referee sample. The in-place air voids will be determined based on the bulk specific gravity of the cores, as determined by the referee laboratory and the Engineer's average maximum theoretical specific gravity for the lot. With the exception of "remove and replace" conditions, referee test results are final and will establish payment adjustment factors for the subplot in question. The Contractor may decline referee testing and accept the Engineer's test results when the placement payment adjustment factor for any subplot results in a "remove and replace" condition. Placement sublots subject to be removed and replaced will be further evaluated in accordance with Section 344.6.2.2., "Placement Sublots Subject to Removal and Replacement."

4.9.2. **Production Acceptance.**

4.9.2.1. **Production Lot.** A production lot consists of 4 equal sublots. The default quantity for Lot 1 is 1,000 tons; however, when requested by the Contractor, the Engineer may increase the quantity for Lot 1 to no more than 4,000 tons. The Engineer will select subsequent lot sizes based on the anticipated daily production such that approximately 3 to 4 sublots are produced each day. The lot size will be between 1,000 tons and 4,000 tons. The Engineer may change the lot size before the Contractor begins any lot.

If the optimum asphalt binder content for JMF2 is more than 0.5% lower than the optimum asphalt binder content for JMF1, the Engineer may perform or require the Contractor to perform [Tex-226-F](#) on Lot 1 to confirm the indirect tensile strength does not exceed 200 psi. Take corrective action to bring the mixture within specification compliance if the indirect tensile strength exceeds 200 psi unless otherwise directed.

4.9.2.1.1. **Incomplete Production Lots.** If a lot is begun but cannot be completed, such as on the last day of production or in other circumstances deemed appropriate, the Engineer may close the lot. Adjust the payment for the incomplete lot in accordance with Section 344.6.1., "Production Payment Adjustment Factors." Close all lots within 5 working days unless otherwise allowed.

4.9.2.2. **Production Sampling.**

4.9.2.2.1. **Mixture Sampling.** Obtain hot-mix samples from trucks at the plant in accordance with [Tex-222-F](#). The sampler will split each sample into 3 equal portions in accordance with [Tex-200-F](#) and label these portions as "Contractor," "Engineer," and "Referee." The Engineer will perform or witness the sample splitting and take immediate possession of the samples labeled "Engineer" and "Referee." The Engineer will maintain the custody of the samples labeled "Engineer" and "Referee" until the Department's testing is completed.

4.9.2.2.1.1. **Random Sample.** At the beginning of the project, the Engineer will select random numbers for all production sublots. Determine sample locations in accordance with [Tex-225-F](#). Take one sample for each subplot at the randomly selected location. The Engineer will perform or witness the sampling of production sublots.

4.9.2.2.1.2. **Blind Sample.** For one subplot per lot, the Engineer will obtain and test a "blind" sample instead of the random sample collected by the Contractor. Test either the "blind" or the random sample; however, referee testing (if applicable) will be based on a comparison of results from the "blind" sample. The location of the Engineer's "blind" sample will not be disclosed to the Contractor. The Engineer's "blind" sample may be randomly selected in accordance with [Tex-225-F](#) for any subplot or selected at the discretion of the Engineer. The Engineer will use the Contractor's split sample for sublots not sampled by the Engineer.

4.9.2.2.2. **Informational Cantabro and Overlay Testing.** Select one random subplot from Lot 2 or higher for Cantabro and Overlay testing during the first week of production. Obtain and provide the Engineer with approximately 90 lb. (40 kg) of mixture in sealed containers, boxes, or bags labeled with Control Section Job (CSJ), mixture type, lot, and subplot number. The Engineer will ship the mixture to the Construction Division for Cantabro and Overlay testing. Results from these tests will not be used for specification compliance.

4.9.2.2.3. **Asphalt Binder Sampling.** Obtain a 1-qt. sample of the asphalt binder for each lot of mixture produced. Obtain the sample at approximately the same time the mixture random sample is obtained. Sample from a port located immediately upstream from the mixing drum or pug mill in accordance with [Tex-500-C](#), Part II. Label the can with the corresponding lot and subplot numbers and deliver the sample to the Engineer. The Engineer may also obtain independent samples. If obtaining an independent asphalt binder sample, the Engineer will split a sample of the asphalt binder with the Contractor. The Engineer will test at least one asphalt binder sample per project to verify compliance with Item 300, "Asphalts, Oils, and Emulsions."

4.9.2.3. **Production Testing.** The Contractor and Engineer must perform production tests in accordance with Table 15. The Contractor has the option to verify the Engineer's test results on split samples provided by the Engineer. Determine compliance with operational tolerances listed in Table 12 for all sublots.

Take immediate corrective action if the Engineer's laboratory-molded density on any subplot is less than 95.0% or greater than 97.0% to bring the mixture within these tolerances. The Engineer may suspend

operations if the Contractor's corrective actions do not produce acceptable results. The Engineer will allow production to resume when the proposed corrective action is likely to yield acceptable results.

The Engineer may allow alternate methods for determining the asphalt binder content and aggregate gradation if the aggregate mineralogy is such that [Tex-236-F](#) does not yield reliable results. Provide evidence that results from [Tex-236-F](#) are not reliable before requesting permission to use an alternate method unless otherwise directed. Use the applicable test procedure as directed if an alternate test method is allowed.

Table 15
Production and Placement Testing Frequency

Description	Test Method	Minimum Contractor Testing Frequency	Minimum Engineer Testing Frequency
Individual % retained for #8 sieve and larger	Tex-200-F or Tex-236-F	1 per subplot	1 per 12 sublots ¹
Individual % retained for sieves smaller than #8 and larger than #200			
% passing the #200 sieve			
Laboratory-molded density	Tex-207-F	N/A	1 per subplot ¹
Laboratory-molded bulk specific gravity			
In-place air voids			
VMA	Tex-204-F		
Segregation (density profile) ²	Tex-207-F , Part V	1 per subplot	1 per project
Longitudinal joint density	Tex-207-F , Part VII		
Moisture content	Tex-212-F , Part II	When directed	
Theoretical maximum specific (Rice) gravity	Tex-227-F	N/A	1 per subplot ¹
Asphalt binder content	Tex-236-F	1 per subplot	1 per lot ¹
Hamburg Wheel test	Tex-242-F	N/A	1 per project
Recycled Asphalt Shingles (RAS) ³	Tex-217-F , Part III	N/A	
Thermal profile ²	Tex-244-F	1 per subplot	
Asphalt binder sampling and testing	Tex-500-C	1 per lot (sample only)	
Tack coat sampling and testing	Tex-500-C , Part III	N/A	
Boil test ⁴	Tex-530-C	1 per lot	
Cantabro loss ⁵	Tex-245-F	1 per project (sample only)	
Overlay test ⁵	Tex-248-F		

1. For production defined in Section 344.4.9.4., "Exempt Production," the Engineer will test one per day if 100 tons or more are produced. For Exempt Production, no testing is required when less than 100 tons are produced.
2. Not required when a thermal imaging system is used.
3. Testing performed by the Construction Division or designated laboratory.
4. The Engineer may reduce or waive the sampling and testing requirements based on a satisfactory test history.
5. Testing performed by the Construction Division and for informational purposes only.

4.9.2.4. **Operational Tolerances.** Control the production process within the operational tolerances listed in Table 12. When production is suspended, the Engineer will allow production to resume when test results or other information indicates the next mixture produced will be within the operational tolerances.

4.9.2.4.1. **Gradation.** Suspend operation and take corrective action if any aggregate is retained on the maximum sieve size shown in Table 8. A subplot is defined as out of tolerance if either the Engineer's or the Contractor's test results are out of operational tolerance. Suspend production when test results for gradation exceed the operational tolerances for 3 consecutive sublots on the same sieve or 4 consecutive sublots on any sieve unless otherwise directed. The consecutive sublots may be from more than one lot.

4.9.2.4.2. **Asphalt Binder Content.** A subplot is defined as out of operational tolerance if either the Engineer's or the Contractor's test results exceed the values listed in Table 12. No production or placement payment adjustments greater than 1.000 will be paid for any subplot that is out of operational tolerance for asphalt binder content. Suspend production and shipment of the mixture if the Engineer's or the Contractor's asphalt binder content deviates from the current JMF by more than 0.5% for any subplot.

4.9.2.4.3. **Voids in Mineral Aggregates (VMA).** The Engineer will determine the VMA for every subplot. For sublots when the Engineer does not determine asphalt binder content, the Engineer will use the asphalt binder content results from QC testing performed by the Contractor to determine VMA.

Take immediate corrective action if the VMA value for any subplot is less than the minimum VMA requirement for production listed in Table 8. Suspend production and shipment of the mixture if the Engineer's VMA results on 2 consecutive sublots are below the minimum VMA requirement for production listed in Table 8. No production or placement payment adjustments greater than 1.000 will be paid for any subplot that does not meet the minimum VMA requirement for production listed in Table 8 based on the Engineer's VMA determination.

Suspend production and shipment of the mixture if the Engineer's VMA result is more than 0.5% below the minimum VMA requirement for production listed in Table 8. In addition to suspending production, the Engineer may require removal and replacement or may allow the subplot to be left in place without payment.

- 4.9.2.4.4. **Hamburg Wheel Test.** The Engineer may perform a Hamburg Wheel test at any time during production, including when the boil test indicates a change in quality from the materials submitted for JMF1. In addition to testing production samples, the Engineer may obtain cores and perform Hamburg Wheel tests on any areas of the roadway where rutting is observed. Suspend production until further Hamburg Wheel tests meet the specified values when the production or core samples fail the Hamburg Wheel test criteria in Table 11. Core samples, if taken, will be obtained from the center of the finished mat or other areas excluding the vehicle wheel paths. The Engineer may require up to the entire subplot of any mixture failing the Hamburg Wheel test to be removed and replaced at the Contractor's expense.

If the Department's or Department approved laboratory's Hamburg Wheel test results in a "remove and replace" condition, the Contractor may request that the Department confirm the results by re-testing the failing material. The Construction Division will perform the Hamburg Wheel tests and determine the final disposition of the material in question based on the Department's test results.

- 4.9.2.5. **Individual Loads of Hot-Mix.** The Engineer can reject individual truckloads of hot-mix. When a load of hot-mix is rejected for reasons other than temperature, contamination, or excessive uncoated particles, the Contractor may request that the rejected load be tested. Make this request within 4 hr. of rejection. The Engineer will sample and test the mixture. If test results are within the operational tolerances shown in Table 12, payment will be made for the load. If test results are not within operational tolerances, no payment will be made for the load.

4.9.3. **Placement Acceptance.**

- 4.9.3.1. **Placement Lot.** A placement lot consists of 4 placement sublots. A placement subplot consists of the area placed during a production subplot.

- 4.9.3.1.1. **Lot 1 Placement.** Placement payment adjustments greater than 1.000 for Lot 1 will be in accordance with Section 344.6.2., "Placement Payment Adjustment Factors;" however, no placement adjustment less than 1.000 will be assessed for any subplot placed in Lot 1 when the in-place air voids are greater than or equal to 2.7% and less than or equal to 9.0%. Remove and replace any subplot with in-place air voids less than 2.7% or greater than 9.0%.

- 4.9.3.1.2. **Incomplete Placement Lots.** An incomplete placement lot consists of the area placed as described in Section 344.4.9.2.1.1., "Incomplete Production Lot," excluding areas defined in Section 344.4.9.3.1.4., "Miscellaneous Areas." Placement sampling is required if the random sample plan for production resulted in a sample being obtained from an incomplete production subplot.

- 4.9.3.1.3. **Shoulders, Ramps, Etc.** Shoulders, ramps, intersections, acceleration lanes, deceleration lanes, and turn lanes are subject to in-place air void determination and payment adjustments unless designated on the plans as not eligible for in-place air void determination. Intersections may be considered miscellaneous areas when determined by the Engineer.

- 4.9.3.1.4. **Miscellaneous Areas.** Miscellaneous areas include areas that typically involve significant handwork or discontinuous paving operations, such as temporary detours, driveways, mailbox turnouts, crossovers, gores, spot level-up areas, and other similar areas. Temporary detours are subject to in-place air void determination when shown on the plans. Miscellaneous areas also include level-ups and thin overlays when

the layer thickness specified on the plans is less than the minimum untrimmed core height eligible for testing shown in Table 13. The specified layer thickness is based on the rate of 110 lb./sq. yd. for each inch of pavement unless another rate is shown on the plans. When "level up" is listed as part of the item bid description code, a payment adjustment factor of 1.000 will be assigned for all placement sublots as described in Article 344.6, "Payment." Miscellaneous areas are not eligible for random placement sampling locations. Compact miscellaneous areas in accordance with Section 344.4.8., "Compaction." Miscellaneous areas are not subject to in-place air void determination, thermal profiles testing, segregation (density profiles), or longitudinal joint density evaluations.

4.9.3.2.

Placement Sampling. The Engineer will select random numbers for all placement sublots at the beginning of the project. The Engineer will provide the Contractor with the placement random numbers immediately after the subplot is completed. Mark the roadway location at the completion of each subplot and record the station number. Determine one random sample location for each placement subplot in accordance with [Tex-225-F](#). Adjust the random sample location by no more than necessary to achieve a 2-ft. clearance if the location is within 2 ft. of a joint or pavement edge.

Shoulders, ramps, intersections, acceleration lanes, deceleration lanes, and turn lanes are always eligible for selection as a random sample location; however, if a random sample location falls on one of these areas and the area is designated on the plans as not subject to in-place air void determination, cores will not be taken for the subplot and a 1.000 pay factor will be assigned to that subplot.

Provide the equipment and means to obtain and trim roadway cores on-site. On-site is defined as in close proximity to where the cores are taken. Obtain the cores within one working day of the time the placement subplot is completed unless otherwise approved. Obtain two 6-in. diameter cores side-by-side from within 1 ft. of the random location provided for the placement subplot. For SP-C and SP-D mixtures, 4-in. diameter cores are allowed. Mark the cores for identification, measure and record the untrimmed core height, and provide the information to the Engineer. The Engineer will witness the coring operation and measurement of the core thickness. Visually inspect each core and verify that the current paving layer is bonded to the underlying layer. Take corrective action if an adequate bond does not exist between the current and underlying layer to ensure that an adequate bond will be achieved during subsequent placement operations.

Trim the cores immediately after obtaining the cores from the roadway in accordance with [Tex-207-F](#) if the core heights meet the minimum untrimmed value listed in Table 13. Trim the cores on-site in the presence of the Engineer. Use a permanent marker or paint pen to record the lot and subplot numbers on each core as well as the designation as Core A or B. The Engineer may require additional information to be marked on the core and may choose to sign or initial the core. The Engineer will take custody of the cores immediately after they are trimmed and will retain custody of the cores until the Department's testing is completed. Before turning the trimmed cores over to the Engineer, the Contractor may wrap the trimmed cores or secure them in a manner that will reduce the risk of possible damage occurring during transport by the Engineer. After testing, the Engineer will return the cores to the Contractor.

The Engineer may have the cores transported back to the Department's laboratory at the HMA plant via the Contractor's haul truck or other designated vehicle. In such cases where the cores will be out of the Engineer's possession during transport, the Engineer will use Department-provided security bags and the Roadway Core Custody protocol located at <http://www.txdot.gov/business/specifications.htm> to provide a secure means and process that protects the integrity of the cores during transport.

Decide whether to include the pair of cores in the air void determination for that subplot if the core height before trimming is less than the minimum untrimmed value shown in Table 13.

Trim the cores as described above before delivering to the Engineer if electing to have the cores included in the air void determination. Deliver untrimmed cores to the Engineer and inform the Engineer of the decision to not have the cores included in air void determination if electing to not have the cores included in air void determination. The placement pay factor for the subplot will be 1.000 if cores will not be included in air void determination.

Instead of the Contractor trimming the cores on-site immediately after coring, the Engineer and the Contractor may mutually agree to have the trimming operations performed at an alternate location such as a field laboratory or other similar location. In such cases, the Engineer will take possession of the cores immediately after they are obtained from the roadway and will retain custody of the cores until testing is completed. Either the Department or Contractor representative may perform trimming of the cores. The Engineer will witness all trimming operations in cases where the Contractor representative performs the trimming operation.

Dry the core holes and tack the sides and bottom immediately after obtaining the cores. Fill the hole with the same type of mixture and properly compact the mixture. Repair core holes with other methods when approved.

4.9.3.3. **Placement Testing.** Perform placement tests in accordance with Table 15. After the Engineer returns the cores, the Contractor may test the cores to verify the Engineer's test results for in-place air voids. The allowable differences between the Contractor's and Engineer's test results are listed in Table 12.

4.9.3.3.1. **In-Place Air Voids.** The Engineer will measure in-place air voids in accordance with [Tex-207-F](#) and [Tex-227-F](#). Before drying to a constant weight, cores may be pre-dried using a Corelok or similar vacuum device to remove excess moisture. The Engineer will average the values obtained for all sublots in the production lot to determine the theoretical maximum specific gravity. The Engineer will use the average air void content for in-place air voids.

The Engineer will use the vacuum method to seal the core if required by [Tex-207-F](#). The Engineer will use the test results from the unsealed core to determine the placement payment adjustment factor if the sealed core yields a higher specific gravity than the unsealed core. After determining the in-place air void content, the Engineer will return the cores and provide test results to the Contractor.

4.9.3.3.2. **Segregation (Density Profile).** Test for segregation using density profiles in accordance with [Tex-207-F](#), Part V. Density profiles are not required and are not applicable when using a thermal imaging system. Density profiles are not applicable in areas described in Section 344.4.9.3.1.4., "Miscellaneous Areas."

Perform a density profile every time the paver stops for more than 60 sec. on areas that are identified by either the Contractor or the Engineer as having thermal segregation, and on any visibly segregated areas unless otherwise approved. Perform a minimum of one profile per subplot if the paver does not stop for more than 60 sec. and there are no visibly segregated areas or areas that are identified as having thermal segregation.

Provide the Engineer with the density profile of every subplot in the lot within one working day of the completion of each lot. Report the results of each density profile in accordance with Section 344.4.2., "Reporting and Responsibilities."

The density profile is considered failing if it exceeds the tolerances in Table 16. No production or placement payment adjustments greater than 1.000 will be paid for any subplot that contains a failing density profile. When a hand-held thermal camera is used instead of a thermal imaging system, the Engineer will measure the density profile at least once per project. The Engineer's density profile results will be used when available. The Engineer may require the Contractor to remove and replace the area in question if the area fails the density profile and has surface irregularities as defined in Section 344.4.9.3.3.5., "Irregularities." The subplot in question may receive a production and placement payment adjustment greater than 1.000, if applicable, when the defective material is successfully removed and replaced.

Investigate density profile failures and take corrective actions during production and placement to eliminate the segregation. Suspend production if 2 consecutive density profiles fail unless otherwise approved. Resume production after the Engineer approves changes to production or placement methods.

Table 16
Segregation (Density Profile) Acceptance Criteria

Mixture Type	Maximum Allowable Density Range (Highest to Lowest)	Maximum Allowable Density Range (Average to Lowest)
SP-A & SP-B	8.0 pcf	5.0 pcf
SP-C & SP-D	6.0 pcf	3.0 pcf

4.9.3.3.3. **Longitudinal Joint Density.**

4.9.3.3.3.1. **Informational Tests.** Perform joint density evaluations while establishing the rolling pattern and verify that the joint density is no more than 3.0 pcf below the density taken at or near the center of the mat. Adjust the rolling pattern, if needed, to achieve the desired joint density. Perform additional joint density evaluations at least once per subplot unless otherwise directed.

4.9.3.3.3.2. **Record Tests.** Perform a joint density evaluation for each subplot at each pavement edge that is or will become a longitudinal joint. Joint density evaluations are not applicable in areas described in Section 344.4.9.3.1.4., "Miscellaneous Areas." Determine the joint density in accordance with [Tex-207-F](#), Part VII. Record the joint density information and submit results on Department forms to the Engineer. The evaluation is considered failing if the joint density is more than 3.0 pcf below the density taken at the core random sample location and the correlated joint density is less than 90.0%. The Engineer will make independent joint density verification at least once per project and may make independent joint density verifications at the random sample locations. The Engineer's joint density test results will be used when available.

Provide the Engineer with the joint density of every subplot in the lot within one working day of the completion of each lot. Report the results of each joint density in accordance with Section 344.4.2., "Reporting and Responsibilities."

Investigate joint density failures and take corrective actions during production and placement to improve the joint density. Suspend production if the evaluations on 2 consecutive sublots fail unless otherwise approved. Resume production after the Engineer approves changes to production or placement methods.

4.9.3.3.4. **Recovered Asphalt Dynamic Shear Rheometer (DSR).** The Engineer may take production samples or cores from suspect areas of the project to determine recovered asphalt properties. Asphalt binders with an aging ratio greater than 3.5 do not meet the requirements for recovered asphalt properties and may be deemed defective when tested and evaluated by the Construction Division. The aging ratio is the DSR value of the extracted binder divided by the DSR value of the original unaged binder. Obtain DSR values in accordance with AASHTO T 315 at the specified high temperature performance grade of the asphalt. The Engineer may require removal and replacement of the defective material at the Contractor's expense. The asphalt binder will be recovered for testing from production samples or cores in accordance with [Tex-211-F](#).

4.9.3.3.5. **Irregularities.** Identify and correct irregularities including segregation, rutting, raveling, flushing, fat spots, mat slippage, irregular color, irregular texture, roller marks, tears, gouges, streaks, uncoated aggregate particles, or broken aggregate particles. The Engineer may also identify irregularities, and in such cases, the Engineer will promptly notify the Contractor. If the Engineer determines that the irregularity will adversely affect pavement performance, the Engineer may require the Contractor to remove and replace (at the Contractor's expense) areas of the pavement that contain irregularities and areas where the mixture does not bond to the existing pavement.

If irregularities are detected, the Engineer may require the Contractor to immediately suspend operations or may allow the Contractor to continue operations for no more than one day while the Contractor is taking appropriate corrective action.

4.9.4. **Exempt Production.** The Engineer may deem the mixture as exempt production for the following conditions:

- anticipated daily production is less than 1,000 tons;
- total production for the project is less than 5,000 tons;

- when mutually agreed between the Engineer and the Contractor; or
- when shown on the plans.

For exempt production, the Contractor is relieved of all production and placement QC/QA sampling and testing requirements, and the production and placement pay factors are 1.000. All other specification requirements apply, and the Engineer will perform acceptance tests for production and placement listed in Table 15 when 100 tons or more per day are produced.

For exempt production:

- produce, haul, place, and compact the mixture in compliance with the specification and as directed;
- control mixture production to yield a laboratory-molded density that is within $\pm 1.0\%$ of the target laboratory-molded density as tested by the Engineer;
- compact the mixture in accordance with Section 344.4.8., "Compaction"; and
- when a thermal imaging system is not used, the Engineer may perform segregation (density profiles) and thermal profiles in accordance with the specification.

- 4.9.5. **Ride Quality.** Measure ride quality in accordance with Item 585, "Ride Quality for Pavement Surfaces," unless otherwise shown on the plans.

5. MEASUREMENT

Hot mix will be measured by the ton of composite hot-mix, which includes asphalt, aggregate, and additives. Measure the weight on scales in accordance with Item 520, "Weighing and Measuring Equipment."

6. PAYMENT

The work performed and materials furnished in accordance with this Item and measured as provided under Article 344.5., "Measurement," will be paid for at the unit bid price for "Superpave Mixtures" of the mixture type, SAC, and binder specified. These prices are full compensation for surface preparation, materials including tack coat, placement, equipment, labor, tools, and incidentals.

Payment adjustments will be applied as determined in this Item; however, a payment adjustment factor of 1.000 will be assigned for all placement sublots for "level ups" only when "level up" is listed as part of the item bid description code. A payment adjustment factor of 1.000 will be assigned to all production and placement sublots when "exempt" is listed as part of the item bid description code.

Payment for each subplot, including applicable payment adjustments greater than 1.000, will only be paid for sublots when the Contractor supplies the Engineer with the required documentation for production and placement QC/QA, thermal profiles, segregation density profiles, and longitudinal joint densities in accordance with Section 344.4.2., "Reporting and Responsibilities." When a thermal imaging system is used, documentation is not required for thermal profiles or segregation density profiles on individual sublots; however, the thermal imaging system automated reports described in [Tex-244-F](#) are required.

Trial batches will not be paid for unless they are included in pavement work approved by the Department.

Payment adjustment for ride quality will be determined in accordance with Item 585, "Ride Quality for Pavement Surfaces."

- 6.1. **Production Payment Adjustment Factors.** The production payment adjustment factor is based on the laboratory-molded density using the Engineer's test results. A payment adjustment factor will be determined from Table 17 for each subplot using the deviation from the target laboratory-molded density defined in Table 10. The production payment adjustment factor for completed lots will be the average of the payment adjustment factors for the 4 sublots sampled within that lot.

Table 17
Production Payment Adjustment Factors for Laboratory-Molded Density¹

Absolute Deviation from Target Laboratory-Molded Density	Production Payment Adjustment Factor (Target Laboratory-Molded Density)
0.0	1.075
0.1	1.075
0.2	1.075
0.3	1.066
0.4	1.057
0.5	1.047
0.6	1.038
0.7	1.029
0.8	1.019
0.9	1.010
1.0	1.000
1.1	0.900
1.2	0.800
1.3	0.700
> 1.3	Remove and replace

1. If the Engineer's laboratory-molded density on any subplot is less than 95.0% or greater than 97.0%, take immediate corrective action to bring the mixture within these tolerances. The Engineer may suspend operations if the Contractor's corrective actions do not produce acceptable results. The Engineer will allow production to resume when the proposed corrective action is likely to yield acceptable results.

- 6.1.1. **Payment for Incomplete Production Lots.** Production payment adjustments for incomplete lots, described under Section 344.4.9.2.1.1., "Incomplete Production Lots," will be calculated using the average production pay factors from all sublots sampled. A production payment factor of 1.000 will be assigned to any lot when the random sampling plan did not result in collection of any samples.
- 6.1.2. **Production Sublots Subject to Removal and Replacement.** If after referee testing, the laboratory-molded density for any subplot results in a "remove and replace" condition as listed in Table 17, the Engineer may require removal and replacement or may allow the subplot to be left in place without payment. The Engineer may also accept the subplot in accordance with Section 5.3.1., "Acceptance of Defective or Unauthorized Work." Replacement material meeting the requirements of this Item will be paid for in accordance with this Section.
- 6.2. **Placement Payment Adjustment Factors.** The placement payment adjustment factor is based on in-place air voids using the Engineer's test results. A payment adjustment factor will be determined from Table 18 for each subplot that requires in-place air void measurement. A placement payment adjustment factor of 1.000 will be assigned to the entire subplot when the random sample location falls in an area designated on the plans as not subject to in-place air void determination. A placement payment adjustment factor of 1.000 will be assigned to quantities placed in areas described in Section 344.4.9.3.1.4., "Miscellaneous Areas." The placement payment adjustment factor for completed lots will be the average of the placement payment adjustment factors for up to 4 sublots within that lot.

Table 18
Placement Payment Adjustment Factors for In-Place Air Voids

In-Place Air Voids	Placement Payment Adjustment Factor	In-Place Air Voids	Placement Payment Adjustment Factor
< 2.7	Remove and Replace	5.9	1.048
2.7	0.710	6.0	1.045
2.8	0.740	6.1	1.042
2.9	0.770	6.2	1.039
3.0	0.800	6.3	1.036
3.1	0.830	6.4	1.033
3.2	0.860	6.5	1.030
3.3	0.890	6.6	1.027
3.4	0.920	6.7	1.024
3.5	0.950	6.8	1.021
3.6	0.980	6.9	1.018
3.7	1.000	7.0	1.015
3.8	1.015	7.1	1.012
3.9	1.030	7.2	1.009
4.0	1.045	7.3	1.006
4.1	1.060	7.4	1.003
4.2	1.075	7.5	1.000
4.3	1.075	7.6	0.980
4.4	1.075	7.7	0.960
4.5	1.075	7.8	0.940
4.6	1.075	7.9	0.920
4.7	1.075	8.0	0.900
4.8	1.075	8.1	0.880
4.9	1.075	8.2	0.860
5.0	1.075	8.3	0.840
5.1	1.072	8.4	0.820
5.2	1.069	8.5	0.800
5.3	1.066	8.6	0.780
5.4	1.063	8.7	0.760
5.5	1.060	8.8	0.740
5.6	1.057	8.9	0.720
5.7	1.054	9.0	0.700
5.8	1.051	> 9.0	Remove and Replace

6.2.1. **Payment for Incomplete Placement Lots.** Payment adjustments for incomplete placement lots described under Section 344.4.9.3.1.2., “Incomplete Placement Lots,” will be calculated using the average of the placement pay factors from all sublots sampled and sublots where the random location falls in an area designated on the plans as not eligible for in-place air void determination. A placement payment adjustment factor of 1.000 will be assigned to any lot when the random sampling plan did not result in collection of any samples.

6.2.2. **Placement Sublots Subject to Removal and Replacement.** If after referee testing, the placement payment adjustment factor for any subplot results in a “remove and replace” condition as listed in Table 18, the Engineer will choose the location of 2 cores to be taken within 3 ft. of the original failing core location. The Contractor will obtain the cores in the presence of the Engineer. The Engineer will take immediate possession of the untrimmed cores and submit the untrimmed cores to the Construction Division, where they will be trimmed, if necessary, and tested for bulk specific gravity within 10 working days of receipt.

The average bulk specific gravity of the cores will be divided by the Engineer’s average maximum theoretical specific gravity for that lot to determine the new payment adjustment factor of the subplot in question. If the new payment adjustment factor is 0.700 or greater, the new payment adjustment factor will apply to that subplot. If the new payment adjustment factor is less than 0.700, no payment will be made for the subplot. Remove and replace the failing subplot, or the Engineer may allow the subplot to be left in place without payment. The Engineer may also accept the subplot in accordance with Section 5.3.1., “Acceptance of Defective or Unauthorized Work.” Replacement material meeting the requirements of this Item will be paid for in accordance with this Section.

- 6.3. **Total Adjusted Pay Calculation.** Total adjusted pay (TAP) will be based on the applicable payment adjustment factors for production and placement for each lot.

$$TAP = (A+B)/2$$

where:

A = Bid price × production lot quantity × average payment adjustment factor for the production lot

B = Bid price × placement lot quantity × average payment adjustment factor for the placement lot + (bid price × quantity placed in miscellaneous areas × 1.000)

Production lot quantity = Quantity actually placed - quantity left in place without payment

Placement lot quantity = Quantity actually placed - quantity left in place without payment - quantity placed in miscellaneous areas

ITEM 800
SPECIAL SPECIFICATION

SPEED HUMPS,
12-FOOT PARABOLIC ASPHALT CONCRETE HUMPS

DESCRIPTION:

This item shall govern for installation of Speed Humps, 12-foot Parabolic Asphalt Concrete Humps and shall be constructed of materials and workmanship as prescribed by these specifications, at such places as shown on the plans or as designated by the Project Engineer, and in accordance with the designated plan and typical details shown. For the purpose of this specification, all references are in accordance with COSA Standard Specifications latest edition.

MATERIALS:

Asphalt

Asphalt concrete shall be Type D, PG 64-22, in accordance with the provisions of Item 205, "Hot Mix Asphaltic Concrete Pavement," of the Standard Specifications.

Tack Coat

All Tack Coat shall conform to the provisions of Item 203, "Tack Coat." Tack coat must be applied prior to installation of all speed humps along all edges of milled limits. Tack coat shall be SS-1H type emulsion applied at a rate of 0.02 gallons per square yard up to a maximum of 0.10 gallons per square yard.

The area to which tack coat has been applied shall be closed to public traffic. Care shall be taken to avoid tracking binder material onto existing pavement and concrete surfaces beyond the limits of construction.

No traffic shall be allowed on to the area to which tack coat has been applied with the exception of vehicles unloading asphalt concrete. All vehicles involved with the Contractor's operations shall turn around within the road right-of-way. Driveways and other private property shall not be used without prior written consent of the involved property owner, a dated copy of which shall be delivered to the Engineer prior to the use thereof.

Striping

Pavement markings shall be white in color, triangular in shape, and placed on the Asphalt Hump as shown on Hump detail. Striping to be placed in accordance with Item 536 "Preformed Pavement Markings." White and yellow temporary tabs shall be placed the same day the speed humps are installed in accordance with the speed hump detail. Payment for temporary tabs is subsidiary to the cost of speed humps. Permanent striping shall be completed 14 days after installation of the speed humps.

Signs and Sign Post

Signs and Sign post shall be supplied by the contractor and installed per COSA specification 531 "Signs."

CONSTRUCTION DETAIL:

General

At least 5 calendar days prior to commencing installation of speed humps, contractor is to provide written notification of planned work to the residents of the street receiving such treatment, residents of any intersecting streets up to one block away, and to Projectmanager.

Project Manager will notify Office of Emergency Services, local City office, City School Districts and any other interested parties that installation of speed humps is scheduled to take place.

Notification of residents is to be type written and shall contain information informing the residents of planned work, and is to be approved by Project Manager before distribution. Notification is to be placed on front door and distributed to all residents as required. Contractor shall not place notices in property owner's mailbox.

In conjunction with construction of speed humps, contractor will install all required signage and sign posts. Contractor is responsible to coordinate installation of required signage and sign posts with the construction of speed hump, and is to notify.

Existing street can be temporarily closed on daily basis and during working hours only while speed hump construction is taking place. Existing street must be fully accessible to vehicular traffic at end of each work day. Street closure is to be done with use of appropriate traffic control signs and devises required to maintain and protect traffic per applicable TMUTCD standards.

Adjacent areas disturbed or damaged during construction are to be restored, in kind to satisfaction of Project Manager, immediately following completion of speed hump construction at contractor's expense.

Construction Performance Standards

The Engineer will not accept any speed hump that is less than three inches (3") in height or exceeds a maximum three and one-half inches (3-1/2") in height or that is not of the shape shown in the 12-Foot Parabolic Asphalt Concrete Speed Hump Detail.

Cross section and profile of each and every speed hump are to be surveyed to verify that each speed hump has been constructed in required shape, and that it falls with required tolerance range.

Take any steps necessary to correct any deficiencies that fall outside of required tolerance.

Construction Installation

Asphaltic concrete pavements shall be cut with a concrete saw. Sawcut existing asphalt to the shape of the new speed hump and mill out a minimum of 2.0 inches of existing material for installation of proposed speed hump. The depth of the cut shall be such that upon removal of the asphaltic concrete, the sides of the cut will be straight and square. Thoroughly clean pavement surface and apply tack coat making sure to completely cover surface area. Tack coat

must be applied before placement of new asphalt material, and between any and subsequent asphalt courses.

Milling of the existing concrete shall conform to Item 208, “Salvaging, Hauling & Stockpiling Reclaimable Asphaltic Pavement.”

12-Foot Parabolic Asphalt Concrete Hump:

- a. A template shall be constructed to verify accuracy of then hump profile and to ensure that the desired vertical dimensions are attained within 0.5-inch tolerance, provided that the hump does not exceed 3.5-inches in height.
- b. Humps shall be constructed under this item with hot mix asphaltic concrete pavement, in the thickness, dimensions and type shown on the plans.
- c. Placing and shaping hump: The asphaltic mixture shall only be dumped and spread on the approved prepared surface. The template shall be constructed to ensure that the desired shape and dimensions of the speed hump are in conformity with the plans and details shown.
- d. The hump shall be constructed one-half width at a time, the contractor must construct the full width of the hump before the end of each working day. No partial speed hump shall be left overnight. Street closures shall comply with Part VI of the *Texas Manual on Uniform Traffic Control Devices*.

Do not perform final rolling operation until required shape of each speed hump in turn has been verified in accordance with applicable tolerances. Contractor to take into account compaction to achieve required dimensions.

Pavement Markings are to be installed according to item 536 “Preformed Pavement Markings.”

Unless otherwise directed by the engineer or designated City Staff, the Contractor shall install posts, speed hump warning and advisory speed signs at the exact locations marked by the Engineer or designated City staff on the pavement in advance of each speed hump. The sign location list and map provided with the Notice to Proceed will show the general locations only. Permanent warning and advisory signs may be installed prior to construction of speed humps. If installed more than one week prior to construction, signs shall remain covered until construction is completed. If not installed prior to construction, warning and advisory signs must be installed within 48 hours of construction.

The Contractor shall construct speed humps at the exact locations marked on the pavement by the Engineer or designated City staff. The speed hump street list and location maps provided with the Notice to Proceed for each phase of the project will show the general locations only.

Street widths in exhibits provided with each Notice to Proceed are measured from lip-of-gutter to lip-of-gutter or face of curb to face of curb as applicable. Measurements are approximate only.

MEASUREMENTS:

Accepted work as prescribed by this Item will be measured by the linear foot perpendicular to the short axis of the 12-foot parabolic speed hump. Saw cutting, excavating and disposal of existing material underneath proposed location of asphalt speed hump will not be measured for payment. Tack Coat will also not be measured for payment.

The Engineer shall make final measurements in the field.

White and yellow temporary tabs will not be measured for payment as they are considered subsidiary to the cost of speedhumps.

Permanent striping will be measured the linear footage of striping installed as per Item 536 "Preformed Pavement Markings."

PAYMENT:

The work performed and materials furnished in accordance with this Item and measured as provided under "Measurement" will be paid for at the unit price bid per linear foot, measured as prescribed above for "Speed Hump, 12-Foot Parabolic Asphalt Concrete Hump." This price is full compensation for removal and disposal of existing speed hump (rubber or asphalt), removal and disposal of existing asphaltic material where proposed speed hump is to be installed, furnishing all materials, preparation, cutting, milling, removing and disposing all surplus materials, furnishing and placing all new materials, and for all manipulations, work, tools, template(s), equipment, traffic control, labor and all other incidentals necessary to complete the work/task.

Payment for pavement markings will be placed under applicable items for Item 536 "Preformed Pavement Markings."

Payment for signs will be placed under applicable items for Item 531 Signs.

Surface restoration shall consist of restoring all areas within the limits of work to their original existing condition prior to construction.

The Contractor shall restore all paved areas, such as driveways, curb and gutter, roadway surfaces, ditches, landscaped areas, etc., and all other improvements disturbed or damaged by his operations at no additional cost to the City.

Payment for the restoration of damaged areas, for which specific bid items are not provided, shall be included in the contract prices paid for various items of work, and no additional compensation will be allowed therefore.

BID ITEM:

Item 800: Speed Hump, 12-Foot Parabolic Asphalt Concrete Hump – per linear foot

ITEM 801

TREE AND LANDSCAPE PROTECTION

This item shall govern the placing of protection for trees and other landscape plant material or natural areas to be protected during construction. No site preparation work shall begin in areas where tree preservation and treatment measures have not been completed and approved. *Where removal of trees is indicated on the drawings, they shall be marked as directed by the engineer or designated representatives.* This item shall also govern the excavation, filling, *trenching and boring* around trees described on the plans, and for furnishing all materials, water, labor, tools, equipment and supplies required as specified by this item or as indicated on the plans.

Reference Standards: City of San Antonio Tree Preservation ordinance # 85262

MATERIALS:

LEVEL I FENCE PROTECTION (Detail 1.1.2):

Fabric: Fabric (4 foot height or 1.2 m) shall consist of orange plastic fencing as shown on the plans and shall be woven with 2-inch (50 mm) mesh openings such that in a vertical dimension of 23 inches (584 mm) along the diagonals of the openings there shall be at least seven meshes.

1. Installation Posts: Installation posts shall be a minimum of 72 inches (1.5 m) long and steel “T” shaped with a minimum weight of 1.3 pounds per linear foot (6.3 kg per meter).
2. Tie Wire: Wire for attaching the fabric to the t-posts shall be not less than No. 12 gauge galvanized wire. Sufficient fastening material shall be furnished to provide for the securing of the fabric to the “T” line posts.
3. Used Materials: Previously-used materials, meeting the above requirements and when approved by the Engineer, may be used.

LEVEL IIA FENCE PROTECTION (Detail 1.1.3):

Materials same as Level I -OR-

LEVEL IIB FENCE PROTECTION (Detail 1.1.4):

1. Sleeve: 2x4 lumber to a height of 4 feet above the root crown.
2. 2x4 shall be utilized as called for on plan.
3. Tie Wire: Wire for securing the 2x4s shall not be less than No. 12 gauge.

OTHER MATERIALS:

1. Tree Dressing - Asphaltic Tree Wound Paint

CONSTRUCTION METHODS:

LEVEL I FENCE PROTECTION:

All trees and shrubs in the proximity of the construction site shall be protected prior to beginning any development activity.

Protective fencing shall be erected outside the dripline at locations shown in the plans or as directed by the Inspector and/or City Arborist or in accordance with the details shown on the plans at the drip line of trees (Root Protection Zone, RPZ) and/or landscape plant material including natural areas. Fencing shall be maintained and repaired by the contractor during site construction.

Protective fence locations in close proximity to street intersections or drives shall adhere to the City of San Antonio’s site distance criteria.

The protective fencing shall be erected before site work commences and shall remain in place during the entire construction phase. Access to fenced areas will be permitted only with the approval of the engineer.

The installation posts will be placed every 6 feet (2 m) around the drip line or RPZ and embedded to 18 inches (457 mm) deep. Fabric attachment shall be attached to the installation posts by the use of sufficient wire ties to securely fasten the fabric to the “T” posts as to hold the fabric in a stable and upright position.

1. Do not clear, fill or grade in the RPZ of any tree.
2. Do not store, stockpile or dump any job material, soil or rubbish under the spread of the tree branches.
3. Do not park or store any equipment or supplies under the spread of the tree branches.
4. Do not set up any construction operations under the spread of the tree branches. (E.g. pipe cutting and threading, mortar mixing, painting or lumber cutting)
5. Do not nail or attach temporary signs, meters, switches, wires, bracing or any other item to the trees.
6. Do not permit runoff from waste materials including solvents, concrete washouts, asphalt tack coats (MC-30 oil), etc. to enter the RPZ. Barriers are to be provided to prevent such runoff substances from entering the RPZ whenever possible, including in an area where rain or surface water could carry such materials to the root system of the tree.

The contractor shall avoid cutting roots larger than one inch in diameter when excavation occurs near existing trees. Excavation in the vicinity of trees shall proceed with caution. The contractor shall contact the city inspector.

Remove all trees, shrubs or bushes to be cleared from protected root zone areas as directed by engineer by hand.

Trees damaged or lost due to contractor’s negligence during construction shall be mitigated at the contractor’s expense and to the engineer’s satisfaction.

Any tree removal shall be approved by the city arborist prior to its removal.

Cover exposed roots at the end of each day with soil, mulch or wet burlap.

In critical root zone areas that cannot be protected during construction and where heavy traffic is anticipated, cover those areas with (8) inches of organic mulch to minimize soil compaction. This (8) inch depth of mulch shall be maintained throughout construction.

Water all trees, most heavily impacted by construction activities, deeply once a week during periods of hot dry weather. Spray tree crowns with water periodically to reduce dust accumulation on the leaves.

When installing concrete adjacent to the root zone of a tree, use a plastic vapor barrier behind the concrete to prohibit leaching of lime into the soil. See related specifications.

When an excavation or embankment is placed within the dripline of any tree greater than (8) inches in diameter, a Tree well shall be constructed to protect the tree as indicated, when the cut or fill exceeds (8) inches. See related specifications.

Where paving or filling is necessary within the dripline of any tree (8) inches or greater, a permeable pavement and aeration system must be installed as indicated. See related specifications.

CONSTRUCTION METHODS:

LEVEL II A FENCE PROTECTION:

Protective fencing shall be erected within the RPZ at locations shown in the plans or as directed by the Inspector and/or City Arborist or in accordance with the details shown on the plans at the drip line of trees (Root Protection Zone, RPZ) and/or landscape plant material including natural areas. Fencing shall be maintained and repaired by the contractor during site construction.

Fabric: Fabric (4 foot height or 1.2 m) shall consist of orange plastic fencing as shown on the plans and shall be woven with 2-inch (50 mm) mesh openings such that in a vertical dimension of 23 inches (584 mm) along the diagonals of the openings there shall be at least seven meshes.

1. Installation Posts: Installation posts shall be a minimum of 72 inches (1.5 m) long and steel "T" shaped with a minimum weight of 1.3 pounds per linear foot (6.3 kg per meter).
2. Tie Wire: Wire for attaching the fabric to the t-posts shall be not less than No. 12 gauge galvanized wire. Sufficient fastening material shall be furnished to provide for the securing of the fabric to the "T" line posts.
3. Used Materials: Previously-used materials, meeting the above requirements and when approved by the Engineer, may be used.

LEVEL II B FENCE PROTECTION:

Trunk protection shall be erected at locations shown in the plans or as directed by the Inspector and/or City Arborist shall be maintained and repaired by the contractor during site construction.

1. Installation Sleeve: 2x4 lumber to a height of 4 feet above the root crown.
2. Tie Wire for securing the 2x4s shall not be less than No. 12 gauge

MEASUREMENT:

Protective fencing will be measured by the linear foot of accepted work, complete in place for the duration of construction activity.

PAYMENT:

Tree and Landscape Protective Fencing will be paid for at the unit price bid per linear foot (meter), which price shall be full compensation for furnishing and placing all materials, manipulation, labor, tools, equipment and incidentals necessary to complete the work.

BID ITEMS

Item 801.1: Level I Protective Fencing - per linear foot (meter)

Item 801.2: Level IIA Protective Fencing - per linear foot (meter)

Item 801.3: Level IIB Protective Fencing - per linear foot (meter)

ITEM 802

TREE PRUNING, SOIL AMENDING AND FERTILIZATION

PART 1 GENERAL

1.01 DESCRIPTION:

The purpose of this specification is to describe a procedure for maintaining preserved trees before, during and after construction and for furnishing all materials, water, labor, tools, equipments and supplies required as specified by this item or as indicated on the plans.

1.02 REFERENCE STANDARDS:

The contractor shall comply with the applicable provisions and recommendations of the publication listed below and these shall be utilized as reference standards, and form a part of this specification to the extent indicated by reference:

American National Standard Institute - ANSI A300-2002

PART 2 PRODUCTS

2.01 MATERIALS:

1. Tree pruning paint: Any latex, oil or asphalt base wound dressing.
2. Soil amendment: Organic soil amendment with nitrogen content 10% or less.
3. Commercial fertilizer: Urea form based liquid suspension, which is soil injected. Salt Index is less than 3.5 (True Green, Boost) and a longevity period of up to 2 years.
4. Mulch: Shredded wood residue with size of pieces not more than 6 inches in length.
5. Water-By truck for trees.

PART 3 EXECUTION

3.01 CARE OF TREES PRIOR TO AND DURING CONSTRUCTION:

1. Prior to erecting tree enclosure and the start of any phase of construction, arborist will provide mycorrhizal inoculation and deep root fertilization to the tree roots, using 3 lbs. of actual nitrogen per 1000 square feet of root area in a slow release soil injection method. Then a certified arborist will perform pruning before construction to remove dead wood, improve the health of the trees to better tolerate the stresses endured during construction activities. In addition all pruning shall adhere to the standard practices in the American National Standard Institute ANS/A300-1995, and to improve the level of safety
 - a. Crown Cleaning – shall consist of the removal of dead, dying, and diseased wood one inch in diameter and greater. Many of the existing trees are above and within the proposed walkway. This dead wood shall be removed to improve safety and liability issues.
2. No site preparation work shall begin in areas where tree preservation and treatment measures have not been completed and approved.
 - a. Crown Raising – shall consist of removing lower limbs to provide a clearance specification of 8 feet over walkways and 13 feet over the

main road for vehicle clearance. Branches may be tied back instead of removed, in order to alleviate conflict. These specifications should protect the existing trees. Tree contractor is to be briefed by Project Engineer/Arborist prior to project commencement. All pruning and removals shall be overseen by a Certified Arborist. The awarded company shall have a Certified Arborist on staff to be able to bid on this Project.

3. No pruning or removal of limbs shall be allowed to provide clearance for work unless approved by the engineer.
4. Removal of limbs which are 6 inches in diameter or greater is prohibited without consent of the City Arborist. Occasional branches, up to 1/4 inch in diameter, which are dead, dying, diseased may remain when it is not practical to remove it.
5. Oak wounds must be painted with wound paint within 30 minutes to prevent infection of the Oak Wilt fungal organism.
6. Soil amendments will be applied within the drip line (RPZ).
7. Soil fertilization will be completed by a soil injection method, which will occur at a spacing of 3 feet on center around the tree within the drip line (Root Protection Zone, RPZ) only for those trees specified.
8. Excavate within drip line of trees only where required. Where excavating for new construction is required within drip line of trees, hand excavate to minimize damage to root systems. Use narrow spading forks and comb soil to expose roots. Relocate roots back into backfill areas wherever possible. If large main lateral roots are encountered, expose beyond excavation limits as required to bend and relocate without breaking. If root relocation is not practical, then contact Client representative for approval to cut roots 1/2" or greater. If approved, clean cut roots using handsaw or chainsaw approximately 3 inches back from new construction. Where existing grade is above new finish grade, carefully excavate within the drip line to the new finish grade. Carefully hand excavate an additional 8 inch below the finish grade. Use narrow line spading forks to comb the soil to expose the roots and prune the exposed root structure as recommended by the Arborist. After pruning and treatment is complete, backfill to within the finish grade with 8" of approved landscape fill material. Temporarily support and protect roots against damage until permanently relocated and do not allow exposure of root to air to occur beyond 12 hours. Cover with damp soil, peat moss, 8"bark or gunny sacks in order to keep moist so as not to dry out and permanently cover roots as soon as possible. Where it has been determined that trenching for utilities can seriously impact the roots of a desirable tree, then bore or tunnel under tree to minimize root impact.
9. The Contractor shall be responsible for coordinating all construction activities that may impact trees with clients representative and the Arborist, who will do the necessary pruning and deep root fertilization deemed necessary by the Arborist.

3.02 POST CONSTRUCTION CARE OF TREES:

1. The Contractor shall water when it is necessary to supplement natural rainfalls required preventing excess drying of the tree root area.

2. The Contractor is responsible for a fall and spring fertilization of the following year using a deep root fertilization method on trees deemed necessary by the Client.
3. The Contractor shall perform post construction care under the supervision of the arborist.

3.03 QUALITY ASSURANCE:

All tree pruning and fertilization work shall be performed by a single firm specializing in tree pruning work, with a minimum of 3 years experience in the acceptable performance of similar work to that specified. Pruning is to be performed by personnel who, by training and on the job experience, are familiar with the techniques and hazards of this work. The firm performing the work shall have the following minimum qualifications and certifications.

NAA - National Arborist Association Certified or
ISA - International Society of Arborists Certification
Be licensed for application and use of pesticides
Meet state requirements for insurance
Must be bonded

The Arborist shall:

- a. Establish lines of communication for all work which may potentially impact trees, under story, or areas that are to be protected from construction activity.
- b. Locate and properly identify or mark in the field trees, under story and areas that are to be protected from construction activity and are the responsibility of the Prime Contractor to protect.
- c. Identify limits and extent of protective fencing around these trees, under story vegetation and other areas.

LEVEL II:

3.04 CARE OF TREES PRIOR TO AND DURING CONSTRUCTION:

1. Prior to erecting tree enclosure and the start of any phase of construction; provide mycorrhizal inoculation and deep root fertilization to the tree roots, using 3 lbs. of actual nitrogen per 1000 square feet of root area. Then pruning will be performed by a certified arborist before construction to remove dead wood, improve the health of the trees to better tolerate the stresses endured during construction activities. In addition all pruning shall adhere to the standard practices in the American National Standard Institute ANS/A300-1995, and to improve the level of safety
2. No site preparation work shall begin in areas where tree preservation and treatment measures have not been completed and approved.
3. No pruning or removal of limbs shall be allowed to provide clearance for work unless approved by the engineer.
4. Removal of limbs which are 6 inches in diameter or greater is prohibited without consent of the City Arborist. Occasional branches, up to 1/4 inch in diameter, which are dead, dying, diseased may remain when it is not practical to remove it.
5. Oak wounds must be painted with wound paint within 30 minutes to prevent infection of the Oak Wilt fungal organism.

6. Excavate within drip line of trees only where required. Where excavating for new construction is required within drip line of trees, hand excavate to minimize damage to root systems. Use narrow spading forks and comb soil to expose roots. Relocate roots back into backfill areas wherever possible. If large main lateral roots are encountered, expose beyond excavation limits as required to bend and relocate without breaking. If root relocation is not practical, then contact Client representative for approval to cut roots 1/2" or greater. If approved, clean cut roots using a handsaw or chainsaw approximately 3 inches back from new construction. Where existing grade is above new finish grade, carefully excavate within the drip line to the new finish grade. Carefully hand excavate an additional 8 inch below the finish grade. Use narrow line spading forks to comb the soil to expose the roots and prune the exposed root structure as recommended by the Arborist. After pruning and treatment is complete, backfill to within the finish grade with 8" of approved landscape fill material. Temporarily support and protect roots against damage until permanently relocated and do not allow exposure of root to air to occur beyond 12 hours. Cover with damp soil, peat moss, bark or gunny sacks in order to keep moist so as not to dry out and permanently cover roots as soon as possible. Where it has been determined that trenching for utilities can seriously impact the roots of a desirable tree, then bore or tunnel under tree to minimize root impact.
7. Water deeply trees that are substantially trimmed or within drip line of excavation work for the duration of this contract.
8. Water deeply trees that show signs of stress and are located in areas where the groundwater table has been lowered due to construction activities.
9. The Contractor shall be responsible for coordinating all construction activities that may impact trees with clients representative and the Arborist, who will do the necessary pruning and deep root fertilization deemed necessary by the Architect.

3.05 POST CONSTRUCTION CARE OF TREES:

1. The Contractor shall water when it is necessary to supplement natural rainfalls required preventing excess drying of the tree root area. Barring natural rainfall, the Contractor should apply 1" per week over entire root protection zone.
2. The Arborist shall monitor and authorize for removal the trees which show symptoms of stress, which might be indicated by branch die back chlorosis or fringe browning of the leaves. This would indicate that the crown is not in equilibrium with roots and additional pruning would be necessary. Subsequent pruning should remove only as much green wood as deemed necessary to reestablish equilibrium. If trees die during construction due to contractor negligence up to a one year post construction period, the Contractor will be required to replace trees at his or her own expense as called for in Paragraph 3.6.
3. The Contractor shall perform post construction care under the supervision of an arborist.

3.06 QUALITY ASSURANCE:

Same as Level I

3.07 MEASUREMENT:

"Maintenance Pruning" Soil Amendment, and Fertilization" , ½" or larger of dead, diseased wood.

"Maintenance Pruning" 1" or larger of dead, diseased wood.

3.08 PAYMENT:

Work performed and materials furnished as prescribed by this item and measured as provided under "Measurement" will be paid for as follows:

"Level I Pruning, Soil Amendment, and Fertilization" Will be paid for at the unit price bid per each tree receiving "Level I Pruning, Soil Amendment, and Fertilization" of the size called for , which price shall be full compensation for furnishing all materials; preparation, hauling, handling charges, placement, labor, tools, and incidentals necessary to complete the work.

Level II Pruning will be paid for at the unit price bid per each location which price shall be full compensation for work herein specified, including the furnishing of all materials, equipment, tools, labor, and incidentals necessary to complete the work.

3.09 BID ITEM:

Item 802.1 - Level II Pruning - per each

Item 802.2 - Level I Pruning, Soil Amendment, and Fertilization - per each

ITEM

804 New Tree & Shrub Planting and Maintenance

804.1 DESCRIPTION: *This item shall govern the procedure for selecting planting and maintaining trees and other vegetation to be used as enhancements or for mitigation on a construction project*

804.2 SELECTION OF TREES:

- A. Size-grading of trees is in accordance with the Texas Association of Nurseryman Grades and Standards. Following is a summary (caliper is measured by a “slot” type caliper, “pincer” type caliper or a diameter tape):
- B. For Shade trees caliper takes precedence. Caliper is measured at 6 inches above soil level in the pot ground for trees up to and including 4 inch caliper size, and 12 inches above the ground for larger trees
- C. For flowering trees, height takes precedence for trees up to 6 feet in height and then caliper
- D. Trees will be a minimum of 2 inch caliper and/or 6 feet in height unless specified.
- E. Trees will be straight, single trunked unless specified or approved.
- F. Trees will be containerized/boxed /balled and burlaped/b&b
- G. No species substitution unless authorized
- H. Trees will be free of insect and diseases with a well-developed rootball no girdling roots
- I. For palm trees, measurement will be by overall height or trunk height and will specify to species or to type; palmate or pinnate
 - If a tree transplant or ball and burlap is approved or specified, it must have been grown out in a nursery for at least 2 growing seasons and ball size must comply with ANSI

804.3 PLANTING:

- A. Excavate pits, beds and trenches with vertical sides and with bottom of excavation slightly raised at center to provide proper drainage
- B. Depth of the excavated area is to be the same as the length of the root ball so that the top of the root flare is at the ground surface level. Minimum depths shall be measured from finished grade
- C. Width of excavation must be a minimum of 3 times the diameter of the root ball.
- D. Loosen hard subsoil in bottom of excavation
- E. Fill excavation for tree/plant with water and allow it to percolate out before planting.
- F. Use excavated parent soil material in the backfill mixture at a ratio of 70:30 with the soil amendment as specified in item 802. Particle size of backfill material must be less than 4 inch diameter

- G. Saturate with water when the pit or bed is half full of backfill and again when full.
- H. Cover excavation area with mulch as specified in item 802
- I. Water to prevent soil from drying out
- J. Plants will be rejected if the ball of earth surrounding roots has been disturbed or damaged prior to or during installation. Replacement tree/plant to be of equal or better quality
- K. Control growth of weeds. Apply a glyphosate type (Round-up 41%) herbicide in the excavated area in accordance with manufacture's label instructions

804.4 QUALITY ASSURANCE:

- A. All tree installation work shall be performed by a single firm specializing in tree transplanting work, with a minimum of 3 years experience in the acceptable performance of similar work to that specified. The firm performing the work shall have the following minimum certifications.
- B. Texas Nurseryman & Landscape Association (TNLA) certification
- C. Be licensed for application and use of pesticides
- D. Meet state requirements for insurance
- E. Must be bonded

804.5 TREE MAINTENANCE POST TRANSPLANTATION:

WATERING THE TREE:

- A. The key to newly planted tree survival is providing adequate water
- B. Contractor shall water the newly planted trees weekly until the end of the one-year warranty. Contractor shall provide a schedule and method of watering the trees to the City for the project
- C. Initially, a newly planted tree needs to be properly watered with an adequate amount to pack the soil, to remove root-drying air and to moisten the root ball.
- D. On adequately draining soils, 5 gallons of initial water should be enough.
- E. Fast draining soils may need more frequent watering than a slow draining soil.
- F. Critical period to provide adequate water during the annual growing season, between late spring and autumn
- G. Use of Gatorbags is acceptable method of irrigation. Follow prescribed irrigation schedule for proper establishment

804.6 MULCHING THE TREE:

- A. Mulching a newly planted tree ensures that moisture is available to roots over time and reduces grass competition
- B. Good mulch (organic materials like leaves, bark, needles and fine wood chips) should ring the tree base (over the critical root zone) but never touch the trunk of the tree. Use local/native hardwood mulch. No fertilizer is necessary when quality composted mulch is used
- C. Maintain the mulch level with no more than 4 inches of material over the roots; mulch should not touch the trunk of the tree. A 3' to 6' minimum radius of mulch should be placed around the tree (the wider the better)

804.7 STAKING THE TREE:

- A. Not all newly planted trees need staking to remain standing straight. Stake only if the root ball is unstable or the tree trunk is bending. Use only loosely-tied wide straps (recommend use of 'Chain-Lock' staking system) and limit the number of straps to a minimum for support
- B. Use tree stakes only when needed. Every tree does not require automatic staking.
- C. Inspect all stakes and straps during spring and autumn for loose fit and alter to prevent trunk damage. All straps should be removed after the first or second year

804.8 INSPECTING TREE HEALTH:

- A. Checking a tree's health should be done by a certified arborist, a Landscape Architect or registered Landscape Professional an expert. Things that can be done to alert of tree health problems
- B. When inspecting a tree consider the following:
- C. Is the current year's growth much less than past years' growth? Although fast growth does not necessarily mean good health, a dramatic reduction in growth rate may be an indication of poor health
- D. Are there dead limbs, odd colors on leaves and bark or a patchy canopy. These tree symptoms can be the first indicators that a tree is unhealthy and should be inspected in detail
- E. Remember that planting a healthy tree in the beginning is the best way to assure its future health

804.9 PRUNING THE TREE:

- A. Prune only critical branches that are either dead or broken after planting. Remove multiple leaders to leave only one central stem. (may be best to postpone pruning to avoid transplanting shock due to loss of leaves)
- B. Prune only critical branches and/or eliminate extra leaders in the tree's first year. Prune lightly in Year 2 or 3

804.10 REPLACEMENT:

- A. Any dead trees or shrubs during the warranty period shall be replaced by the contractor at no cost to the city
- B. At the end of the one-year warranty, any tree or shrub that is not in good condition as determined by the city arborist and project manager shall be replaced by the contractor at no cost to the city

804.11 MEASUREMENT:

Tree installations will be measured by the number and size of trees/plants (cost should include installation, warranty, mulch, irrigation/gatorbags, monitoring/treatments as needed, staking, etc.)

804.12 PAYMENT:

Payment shall be made per each of the type and size of tree specified on the bid proposal

804.13 BID ITEM:

Item 804 – New Tree & Shrub Planting and Maintenance

ITEM NO. 826-a

LOCATING AND ADJUSTING EXISTING VALVE BOXES

826-a 1. DESCRIPTION: This item shall consist of locating valve boxes, cutting asphalt, replacing asphalt, and adjustment of all existing valve boxes in accordance with these applications and as directed by the Engineer or Project Manager.

826-a 2. MATERIALS: The materials for valve boxes shall conform to the specifications contained within the latest revision of SAWS Material Specification Item No. 10-20, Valve Boxes.”

826-a 3. CONSTRUCTION: Construction Methods: Locate valve box using maps and metal detectors. Cut and replace asphalt as necessary. The valve box shall be placed in such a manner to prevent shock or stress from being transmitted to the valve. It shall be centered and plumb over the operating nut of the valve with the box cover flush with the surface of the finished pavement or at such other level as may be directed by the Engineer or Project Manager.

Valve box shall be located so that the valve operating nut is readily accessible for operation through the opening to the valve box. The valve box shall be set flush with the surface of the finished pavement or at such other elevations as may be specified. Pits shall be constructed to permit trainer valve repairs and to afford protection to valve and pipe from impact where they pass through the pit walls.

Existing Valve Box: Existing covered valve boxes shall be defined as those boxes which are located within the right-of-way of the specified area of construction operations which are covered by asphalt. These boxes shall be adjusted to match proposed finished grades.

Adjustment of new valve boxes installed by SAWS will be paid at the contract unit price bid for Item 826 Valve Box Adjustment

826-a 4. MEASUREMENT: Valve Boxes located and completely adjusted, as prescribed above, will be measured by the unit of each valve box located and adjusted to the finished grade. The excavation and the amount of asphalt required to fill the area excavated will not be measured for payment.

826-a 5. PAYMENT: The work performed as prescribed by this item will be paid for at the contract unit price bid per valve box for "Locating and Adjusting Existing Valve Boxes" which price shall be full compensation for all excavation, including saw cutting of surfaces as required, and disposal of material excavated; for furnishing and placing all materials and for all labor, tools, equipment and incidentals necessary to complete the work.

ITEM NO. 851-a

LOCATING AND ADJUSTING EXISTING MANHOLES

851-a 1. DESCRIPTION: This item shall consist of the locating manholes, cutting asphalt, replacing asphalt, and adjustment of all existing manholes to include the replacing of existing manhole covers and rings regardless of type shown on the plans and in conformity with the provisions of these specifications.

851-a 2. CONSTRUCTION: Locate manholes using maps and metal detectors. Cut and replace asphalt as necessary. Manholes shall be lowered below subgrade before placing base materials and openings shall be protected by temporary hatch covers. Existing manhole rings and covers which are determined by the SAWS inspector to be in an unacceptable condition, will be removed and replaced with new rings and cover. Contractor shall take all necessary measures to prevent damage to existing or new rings, covers, or cones from equipment and materials used in, or taken through, the work area. If an existing or new manhole cover, ring, or cone is damaged by the Contractor, it shall be replaced (as directed by SAWS inspector) by the Contractor at his expense. Manholes shall be adjusted after the base material has been laid and before placement of the final surface course. Manholes that are going to be adjusted on an existing surface course (not planned for replacement) will be in accordance with City of San Antonio Utility Excavation Criteria Manual Standard Drawing No. 8.8. All manholes shall then be raised, or lowered a sufficient height so as to be level with the finished surface course. Adjustment in height will be made by the addition or removal of "throat rings" above the manhole cone, where feasible. A minimum of two and a maximum of six "throat rings" shall be used at each adjusted manhole. Material excavation from around the manholes shall be replaced with concrete in accordance with Standard Drawings, and select materials from the excavation (as shown on the plans or specified by the SAWS). All excess materials shall be disposed of by the Contractor at his own expense in an approved location. Contractor shall furnish and install a 5' x 5' x 1" thick steel plate over concrete collars at the discretion of the city inspector or project manager until concrete has reached its ultimate strength. Steel plate shall not be removed until concrete collar around manhole has reached its ultimate strength.

851-a 3. MEASUREMENT: Manholes located and completely adjusted, as prescribed above, will be measured by the unit of each manhole located and adjusted. The excavation, steel plate and the amount of asphalt, concrete or reinforced concrete as necessary to fill the area excavated will not be measured for payment.

851-a 4. PAYMENT: The work performed as prescribed by this item will be paid for at the contract unit price bid per manhole for "Locating and Adjusting Existing Manholes" which price shall be full compensation for all excavation, including saw cutting of surfaces as required, reinforced concrete and disposal of material excavated, 5' x 5' x 1" thick steel plate; for furnishing and placing all materials and for all labor, tools, equipment and incidentals necessary to complete the work.

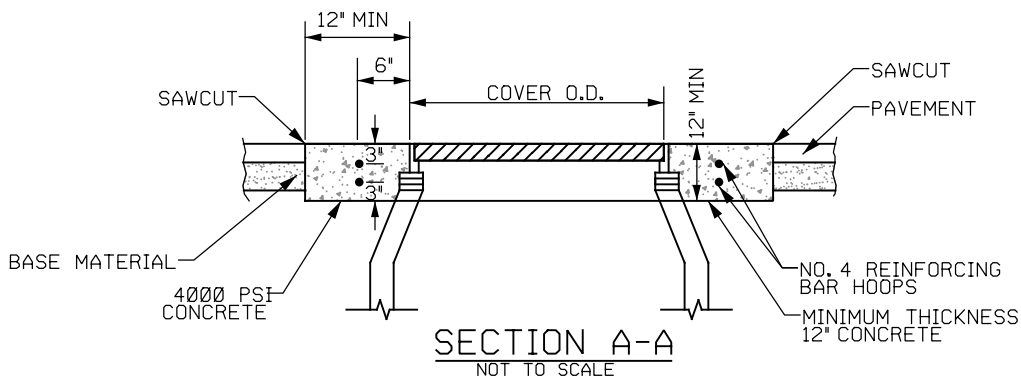

SECTION A-A
NOT TO SCALE

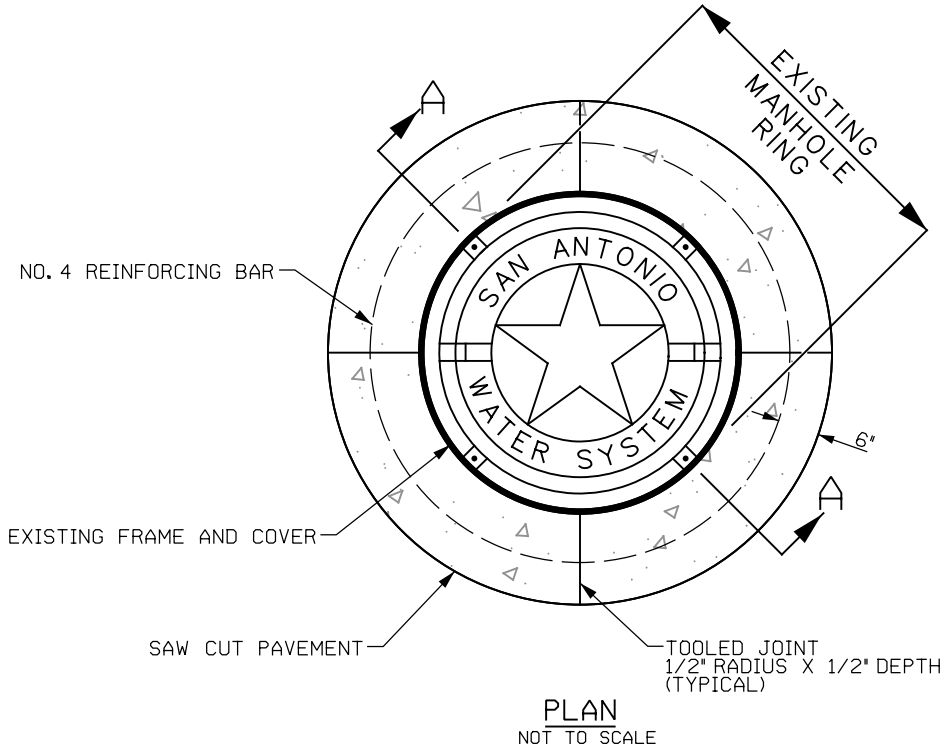

PLAN
NOT TO SCALE

NOTE:

1. CONCRETE SHALL BE 4000 PSI, MIN., AND REINFORCED WITH NO. 4 BARS, AS SHOWN.
2. THE CONCRETE SHALL EXTEND TO THE EDGE OF SAWCUT PAVEMENT.
3. MANHOLE RING ENCASEMENT IS REQUIRED ON ALL NEW, EXISTING, OR ADJUSTED MANHOLES.

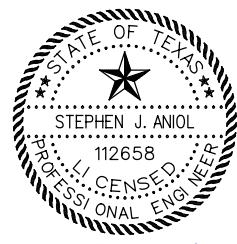

Stephen J. Aniol
8/8/2018

LAN Lockwood, Andrews & Newnam, Inc. <small>A LEO A. DALY COMPANY</small>	
TBPE REGISTRATION NO. F-2614	
CITY OF SAN ANTONIO TRANSPORTATION & CAPITAL IMPROVEMENTS	
COSA SMP CONTRACT MANHOLE ADJUSTMENTS	
MANHOLE CONCRETE ENCASEMENT DETAIL	
% SUBMITTAL	PROJECT NO.:
DATE: AUG-2018	DATE: AUG-2018
DRWN. BY:	DSGN. BY:
CHKD. BY:	SHT: 1 OF 1

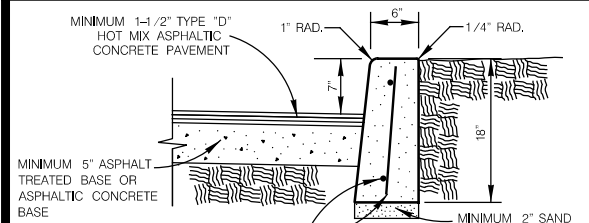

HEADER CURB
ITEM 500 ON SAND OR GRAVEL
SCALE : 1"=2'

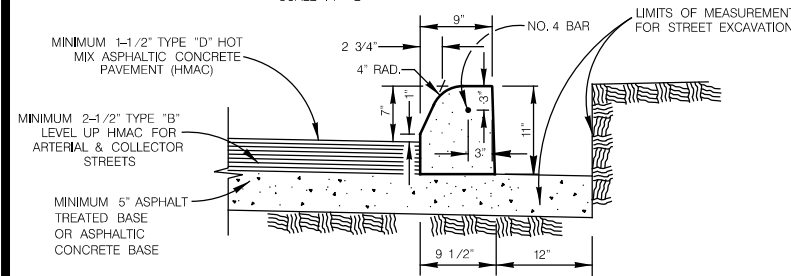

CONCRETE CURB
ITEM 500 ON ASPHALT TREATED BASE OR ASPHALTIC CONCRETE BASE
SCALE : 1"=2'

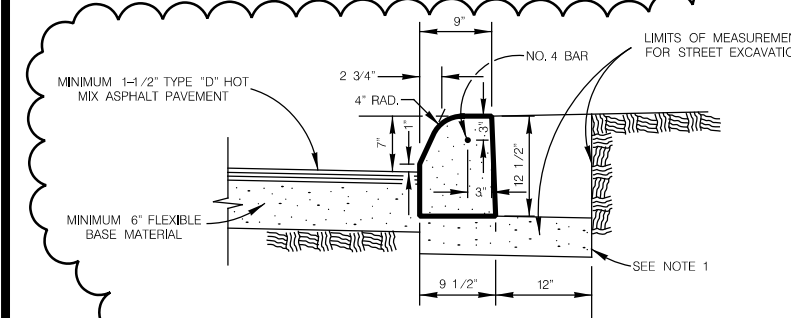

CONCRETE CURB
ITEM 500 ON FLEXIBLE BASE MATERIAL
SCALE : 1"=2'

NOTES :
1. FOR STREETS THAT DO NOT HAVE EXISTING ASPHALT TREATED BASE, A 6" LAYER OF COMPACTED FLEX BASE SHALL BE INSTALLED DIRECTLY UNDERNEATH THE CURB AND UP TO 1' BEYOND.

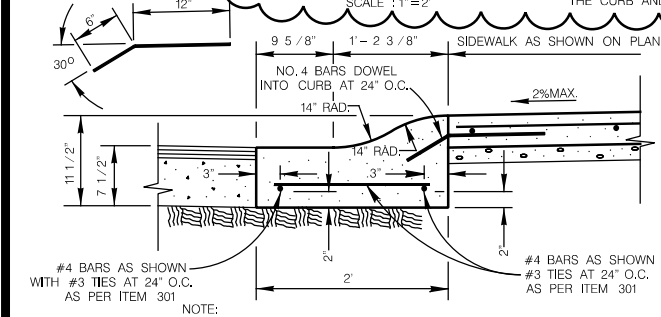

MOUNTABLE CURB
ITEM 500 ON COMPACTED SUBGRADE
SCALE : 1"=2'

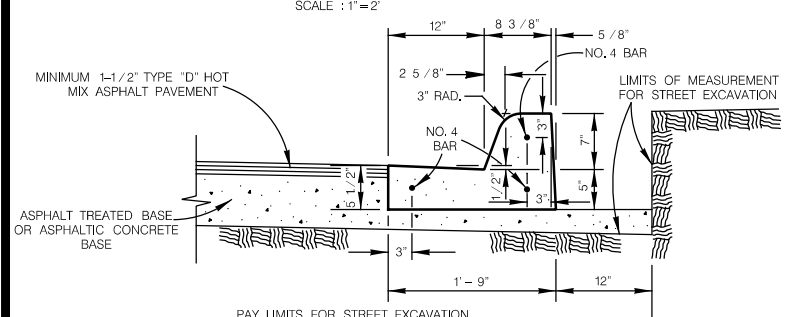

TYPICAL CURB & GUTTER DETAIL
ITEM 500 ON ASPHALT TREATED BASE OR ASPHALTIC CONCRETE BASE
SCALE : 1"=2'

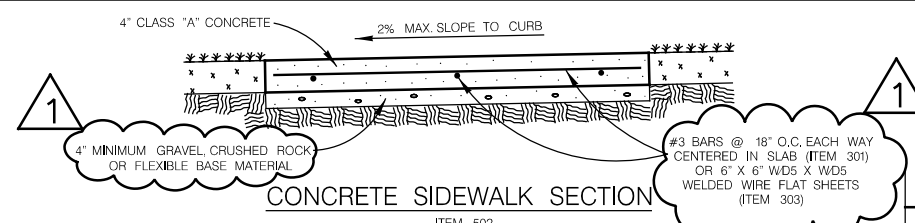

CONCRETE SIDEWALK SECTION
ITEM 502
SCALE : 1"=2'

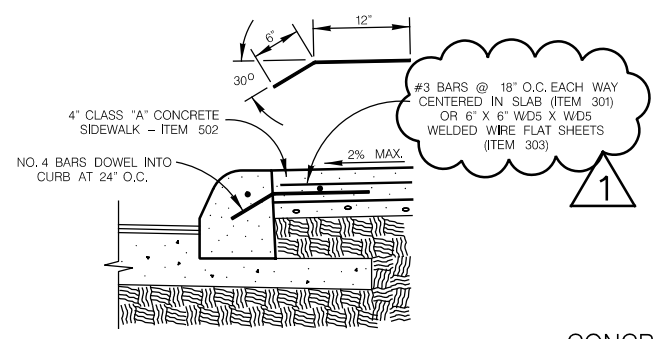

CONCRETE SIDEWALK ABUTTING CURB SECTION
ITEM 502
SCALE : 1"=2'

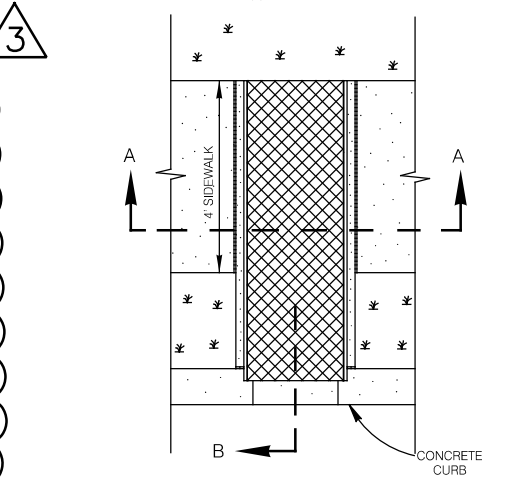

CONCRETE SIDEWALK DRAIN DETAIL
SCALE : 1"=4'

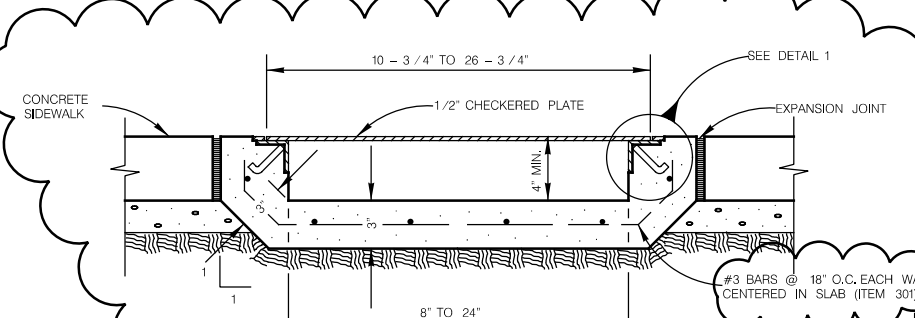

SECTION A-A
SCALE : 1:12

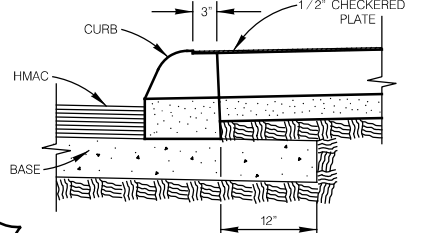

SECTION B
SCALE : 1"=2'

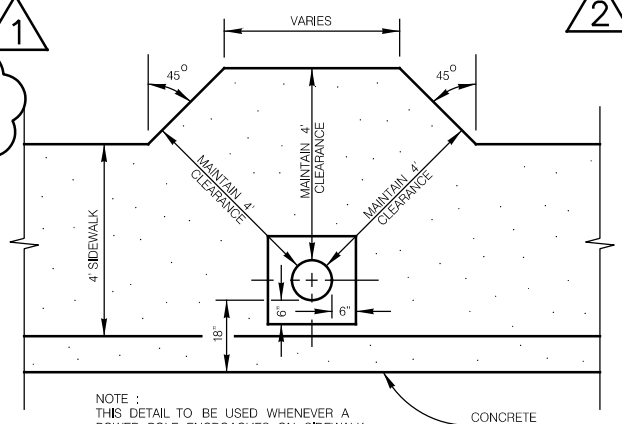
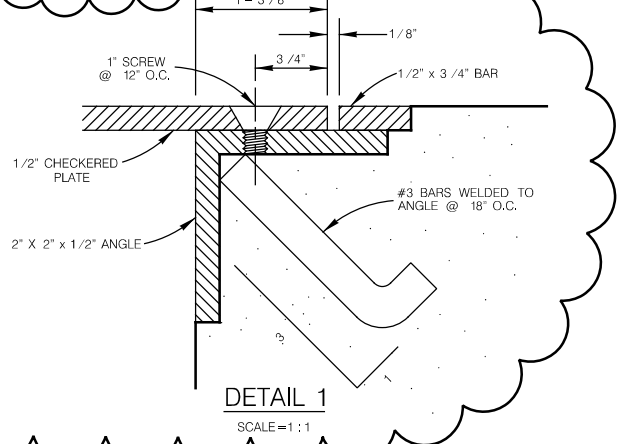

CONCRETE SIDEWALK @ UTILITY POWER POLE DETAIL
SCALE : 1"=4'

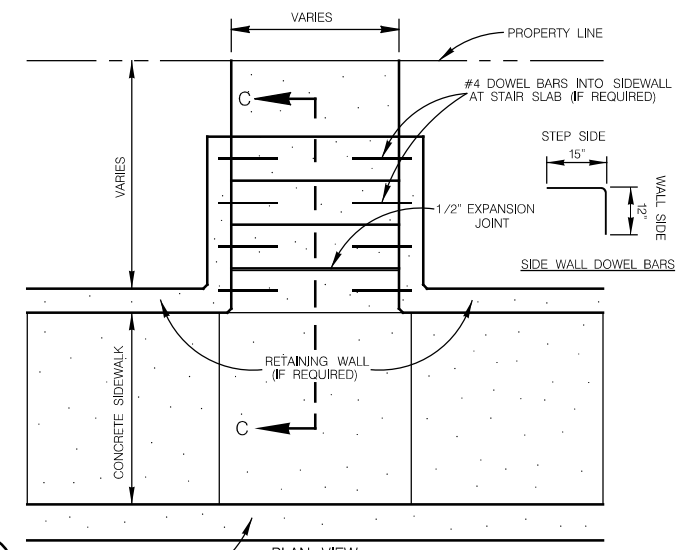

CONCRETE STEPS
ITEM 524

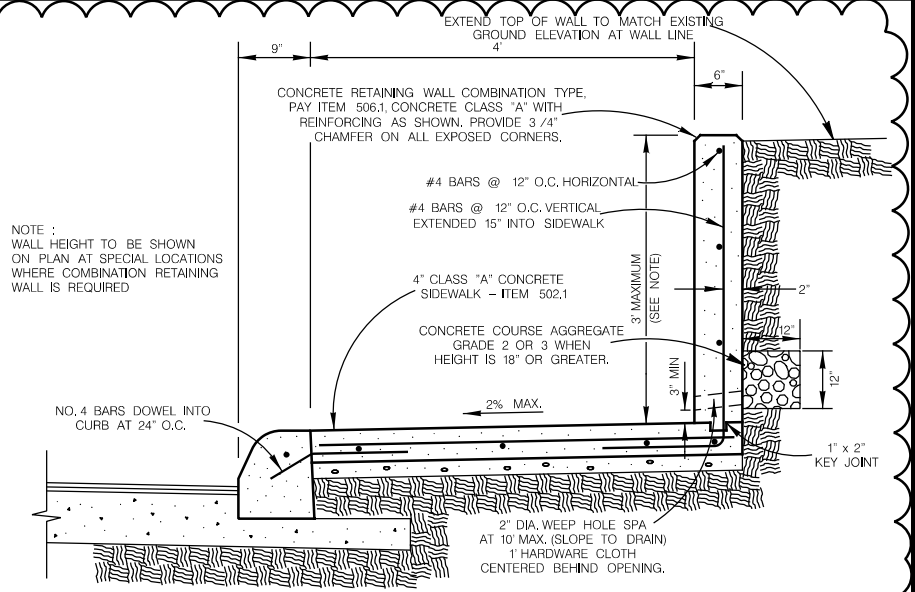
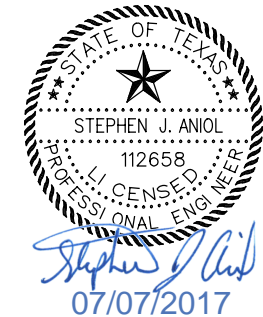
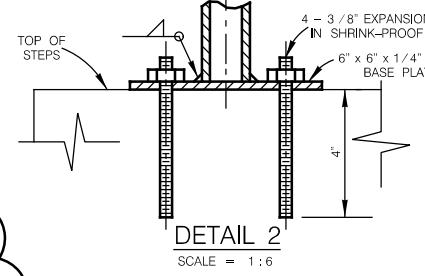

CONCRETE RETAINING WALL - COMBINATION TYPE
ITEM 506
SCALE : N.T.S.

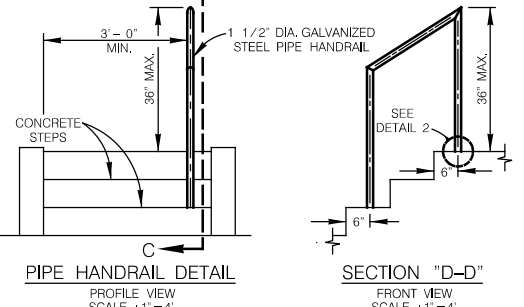
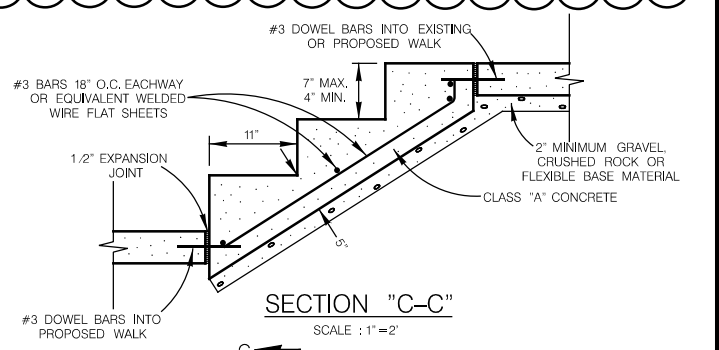

NOTES :
1. PLACE STEPS TO CONFORM WITH PROPOSED PARKWAY GRADING
2. 1-1/2" DIA. GALVANIZED STEEL PIPE HANDRAIL REQUIRED ON ONE SIDE OF THE STEPS WHEN 3 OR MORE RISERS ARE USED, OR AS DESIGNED BY ENGINEER, TO BE PAID UNDER ITEM 522
HANDRAIL FOR CONCRETE STEPS
ITEM 522

REV. NO.	DESCRIPTION	DATE
1	BASE / REINFORCEMENT MODIFICATIONS	7/7/17
2	RETAINING WALL REVISION	7/7/17
3	CURB BEDDING THICKNESS	7/7/17
4	SIDEWALK DRAIN THICKNESS	7/7/17

MAY 2009

CITY OF SAN ANTONIO
CAPITAL IMPROVEMENTS MANAGEMENT SERVICES DEPARTMENT

MISCELLANEOUS
CONSTRUCTION STANDARDS I

DATE	PROJECT NO.	DATE
07/07/2017	V. VASQUEZ	R.S. HOSSAIN, P.E.

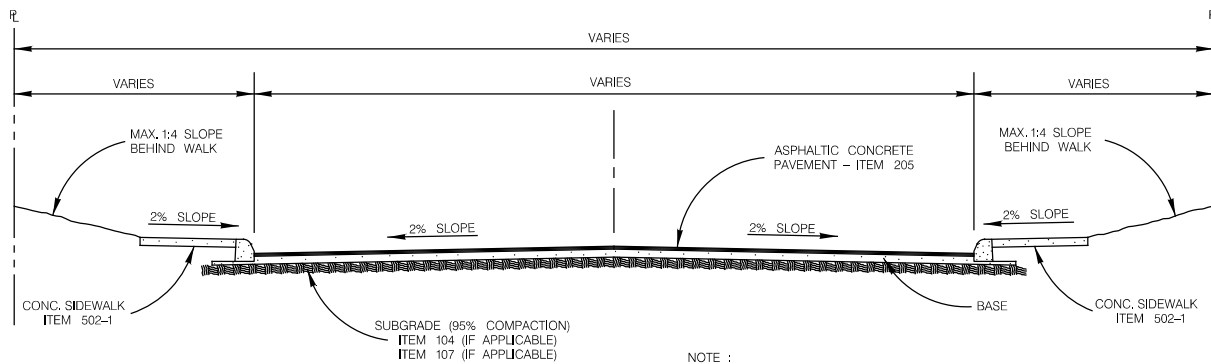

TYPICAL STREET SECTION

SCALE : 1"=8'

NOTE :
FOR STREETS OTHER THAN LOCAL TYPE "A" STREETS,
THE EDGE OF THE SIDEWALK MUST BE LOCATED A
MINIMUM OF TWO FEET AWAY FROM THE BACK OF
THE CURB.

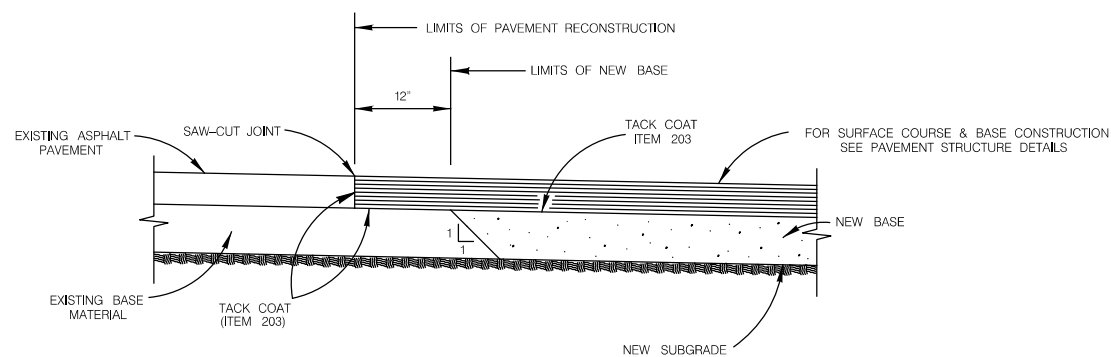

PAVEMENT JUNCTION DETAILS

SCALE : 1"=2'

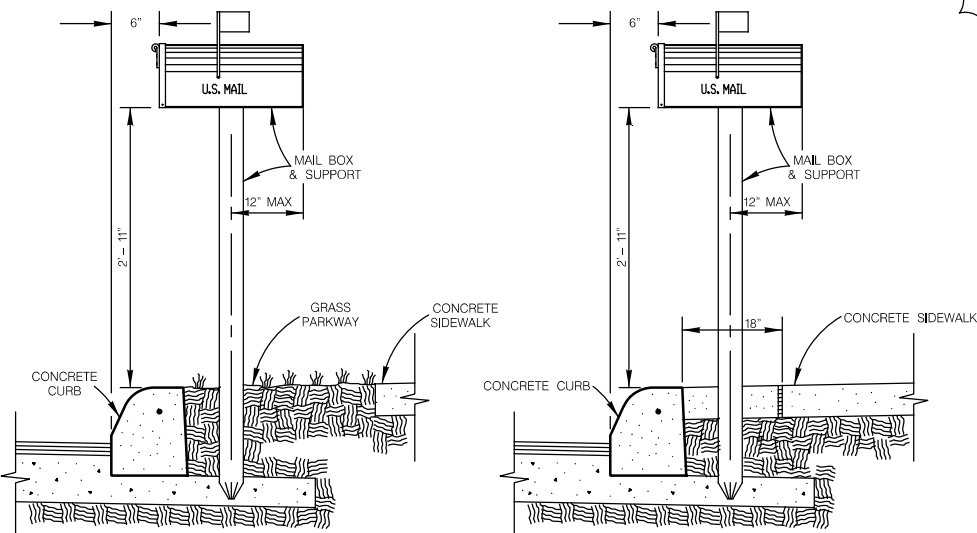

MAIL BOX LOCATION

ITEM 513.1

SCALE : 1"=2'

SCALE : 1"=2'

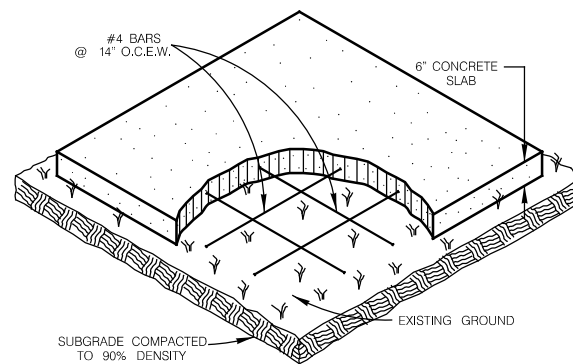

- MAIL BOX PAD NOTES :**
1. THE CONTRACTOR WILL CONSTRUCT SLABS FOR "TEMPORARY MAIL BOX COLLECTION PAD" FOR THE UNITED STATES POSTAL SERVICE WITH LOCATIONS AND SIZES SPECIFIED BY THE CITY ENGINEER DURING CONSTRUCTION.
 2. THE CONSTRUCTION OF SLABS SHALL CONFORM TO ITEM 513 "REMOVING AND RELOCATING MAILBOXES".
 3. PAYMENT WILL BE MADE UNDER ITEM 513.2 "COMMUNITY MAILBOX SLAB - PER SQUARE YARD".
 4. UNIT PRICE WILL INCLUDE REMOVAL OF "TEMPORARY MAIL BOX COLLECTION PAD" SLABS AT THE END OF THE PROJECT. NO SEPARATE PAY ITEM.

COMMUNITY MAIL BOX SLAB

ITEM 513.2
SCALE : 1"=4'

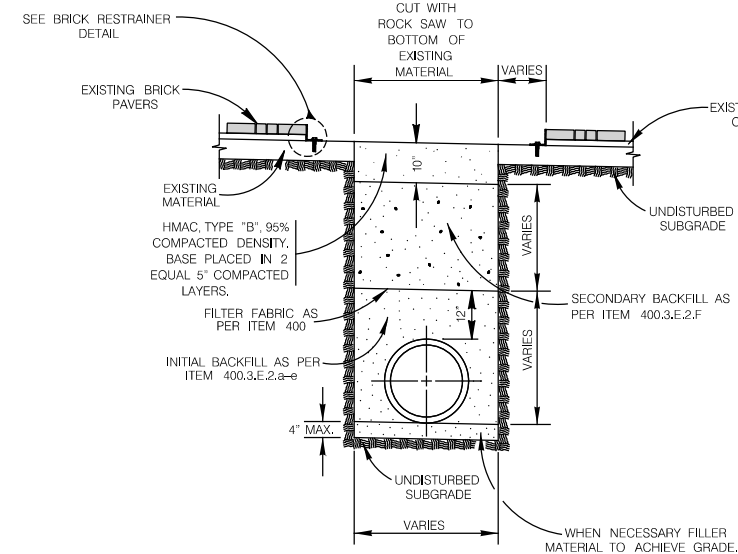

TYPICAL BASE REPLACEMENT FOR BRICK SURFACED STREET SECTION

ITEM 511.3
SCALE : 1"=4'

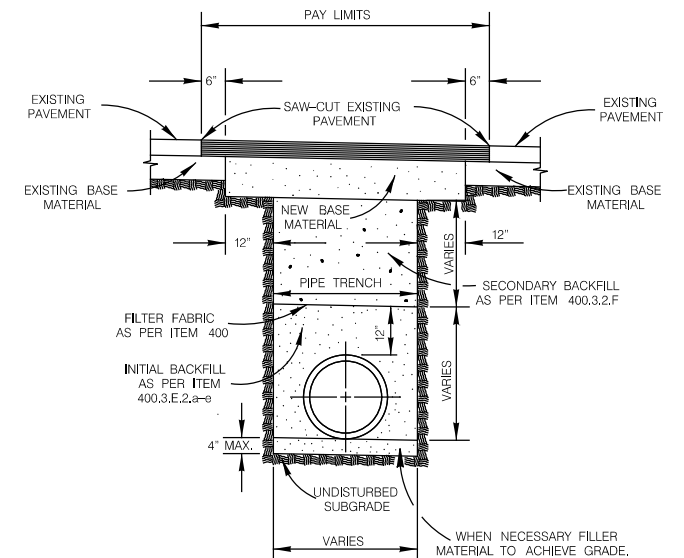

- NOTES :**
1. FOR LOCAL TYPE "A" & "B" STREETS (RESIDENTIAL) USE 6" ASPHALT CONCRETE BASE TYPE "B" WITH 1-1/2" TYPE "D" HOT MIX ASPHALTIC CONCRETE PAVEMENT.
 2. FOR ARTERIAL & SECONDARY STREETS (COMMERCIAL) USE 12.5" TYPE "B" HOT MIX ASPHALTIC CONCRETE PAVEMENT LEVELING-UP COURSE & 1-1/2" TYPE "D" HOT MIX ASPHALTIC CONCRETE PAVEMENT SURFACE COURSE.

TYPICAL PAVEMENT REPLACEMENT

ITEM 511
SCALE : 1"=4'

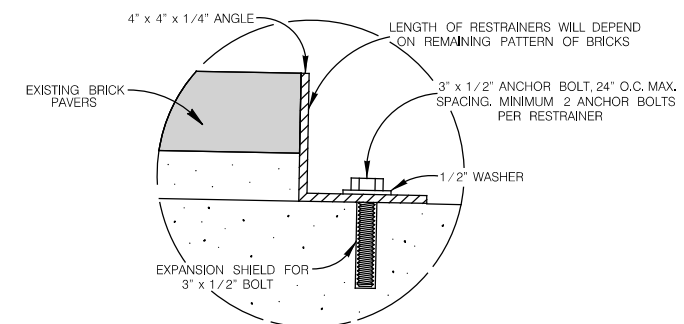

BRICK RESTRAINER DETAIL

SCALE = 1:6

REV. NO.	DESCRIPTION	DATE
1	Modifications	7/7/17

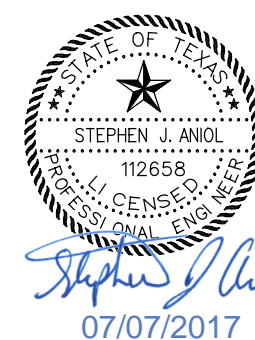

FEBRUARY 2010

CITY OF SAN ANTONIO
CAPITAL IMPROVEMENTS MANAGEMENT SERVICES DEPARTMENT

MISCELLANEOUS
CONSTRUCTION STANDARDS II

% SUBMITTAL	PROJECT NO.:	DATE:
DRWN. BY: V. VASQUEZ	DSGN. BY:	CHKD. BY: R.S. HOSSEINI, P.E.

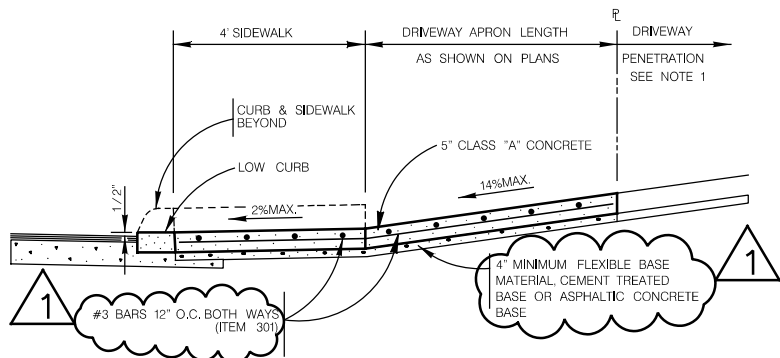

TYPICAL RESIDENTIAL DRIVEWAY SECTION
WITH SIDEWALK ABUTTING CURB
ITEM 503.1

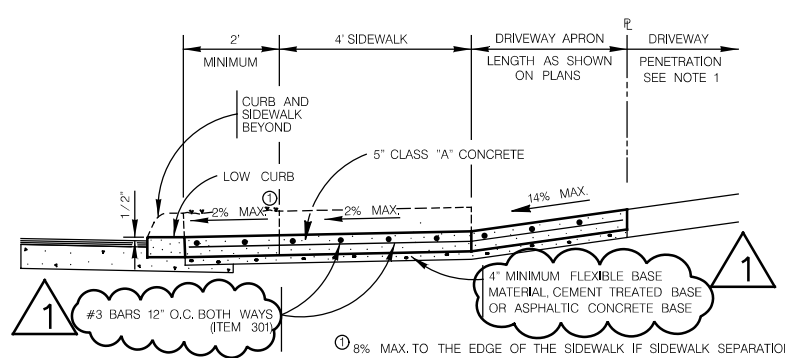

TYPICAL RESIDENTIAL DRIVEWAY SECTION
WITH SIDEWALK SEPARATED FROM CURB
ITEM 503.1

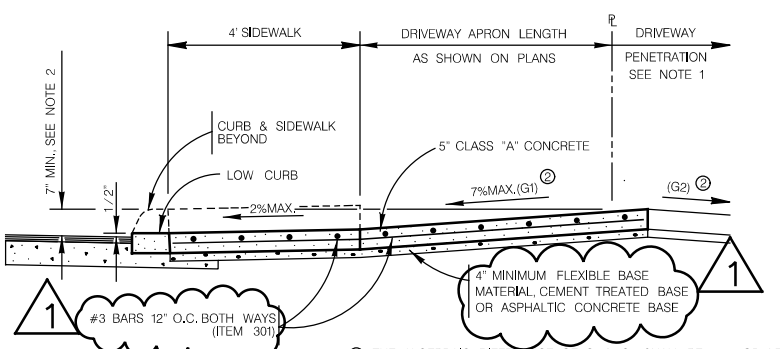

TYPICAL RESIDENTIAL DRIVEWAY SECTION
WHERE PROPERTY IS LOWER THAN STREET & SIDEWALK IS ABUTTING CURB
ITEM 503.1

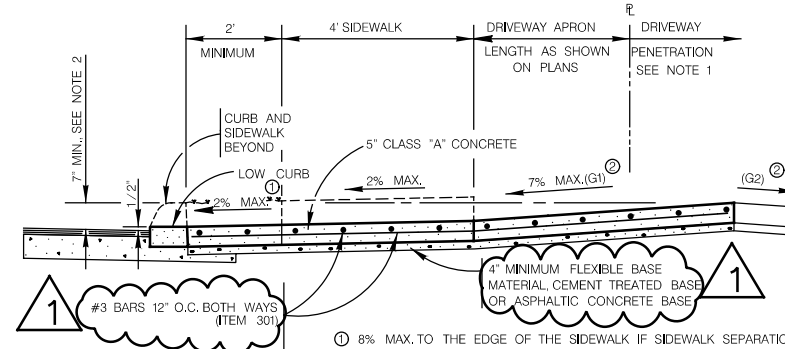

TYPICAL RESIDENTIAL DRIVEWAY SECTION
WHERE PROPERTY IS LOWER THAN STREET & SIDEWALK IS SEPARATED FROM CURB
ITEM 503.1

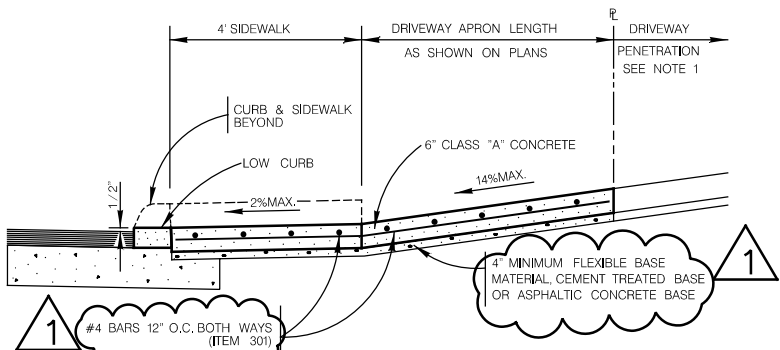

TYPICAL COMMERCIAL DRIVEWAY SECTION
WITH SIDEWALK ABUTTING CURB
ITEM 503.2

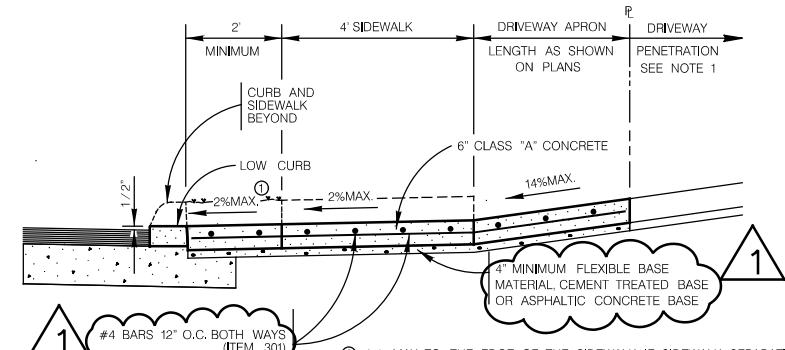

TYPICAL COMMERCIAL DRIVEWAY SECTION
WITH SIDEWALK SEPARATED FROM CURB
ITEM 503.2

CONCRETE DRIVEWAY NOTES

- DRIVEWAY PENETRATION REFERS TO A PORTION OF THE DRIVEWAY THAT MAY BE NECESSARY TO RECONSTRUCT WITHIN PRIVATE PROPERTY TO COMPLY WITH A MAXIMUM DRIVEWAY SLOPE. THIS PORTION OF THE DRIVEWAY SHALL BE PAID FOR UNDER THE FOLLOWING ITEMS AS MAY APPLY:
A.) CONCRETE DRIVEWAY PAID FOR UNDER ITEM NO. 503.1 OR 503.2.
B.) ASPHALTIC CONCRETE DRIVEWAY PAID FOR UNDER ITEM NO. 503.4 AND SHALL INCLUDE A MINIMUM OF 1" ASPHALT TYPE 'D' & 6" FLEXIBLE BASE
C.) GRAVEL DRIVEWAY PAID FOR UNDER ITEM NO. 503.5 AND SHALL INCLUDE A MINIMUM OF 6" FLEXIBLE BASE
- 7' MINIMUM HEIGHT WILL NOT NECESSARILY OCCUR AT THE PROPERTY LINE. IT MAY OCCUR WITHIN THE RIGHT OF WAY OR WITHIN THE DRIVEWAY PENETRATION ON PRIVATE PROPERTY.
- THE PROPOSED DRIVEWAY SHOULD MATCH THE EXISTING WIDTH AT THE PROPERTY LINE BUT UNLESS AUTHORIZED BY THE CITY TRAFFIC ENGINEER, THE WIDTH SHALL BE WITHIN THE FOLLOWING VALUES:

TYPE	MINIMUM	MAXIMUM
RESIDENTIAL	10'	20'
COMMERCIAL - ONE WAY	12'	20'
COMMERCIAL - TWO WAY	24'	30'

- FOR LOCAL TYPE "A" STREETS, SIDEWALK SHALL HAVE A MINIMUM WIDTH OF 4' AND IF SEPARATED FROM THE CURB, THE SIDEWALK SHALL BE LOCATED A MINIMUM OF 2' FROM THE BACK OF CURB.
- FOR OTHER THAN LOCAL TYPE "A" STREETS, THE SIDEWALK SHALL HAVE A MINIMUM WIDTH OF 4' AND SEPARATED A MINIMUM OF 2' FROM THE BACK OF CURB OR, AS AN OPTION, THE SIDEWALK SHALL HAVE A MINIMUM WIDTH OF 6' WHEN LOCATED AT THE BACK OF CURB.
- DUMMY JOINTS PARALLEL TO THE CURB SHALL BE PLACED WHERE THE SIDEWALK MEETS THE DRIVEWAY. DUMMY JOINTS PERPENDICULAR TO THE CURB AND WITHIN THE BOUNDARIES OF THE PARALLEL DUMMY JOINTS, SHALL BE PLACED AT INTERVALS EQUAL TO THE WIDTH OF THE SIDEWALK.
- A MINIMUM OF TWO ROUND AND SMOOTH DOWEL BARS 3/8" IN DIAMETER AND 18" IN LENGTH SHALL BE SPACED 18" APART AT EACH EXPANSION JOINT.
- SIDEWALK RAMP LENGTHS SHALL BE OF SUFFICIENT LENGTH TO MAINTAIN 8.33% (1:12) MAXIMUM SLOPE. WHERE SIDEWALKS CROSS DRIVEWAYS, SIDEWALK CROSS SLOPE SHALL NOT EXCEED 2%.
- SIDEWALK RAMP SURFACE SHALL BE BRUSH FINISHED.

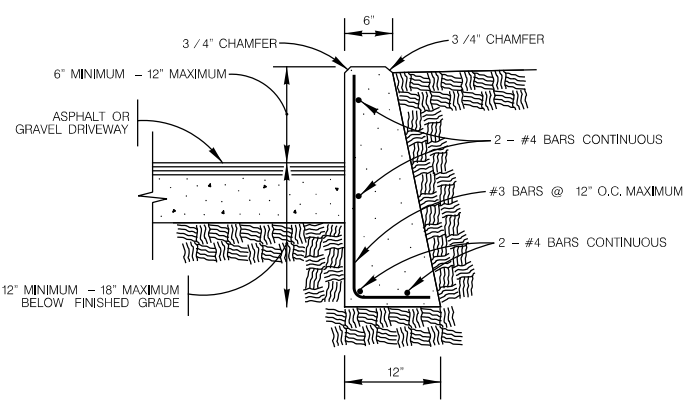

NOTE:
1. COST OF REINFORCEMENT TO BE INCLUDED IN UNIT COST OF ITEM 307.1.
2. CONCRETE RETAINING WALL COMBINATION TYPE SHALL BE USED FOR CONCRETE DRIVEWAYS.

DRIVEWAY - CONCRETE RETAINING WALL
ON COMPACTED SUBGRADE
ITEM 307.1

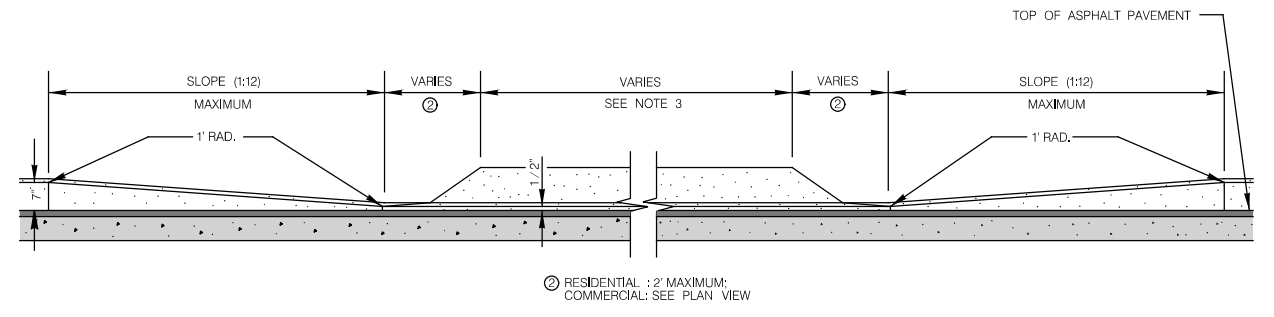

CURB PROFILE AT DRIVEWAY
WITH SIDEWALK ABUTTING CURB

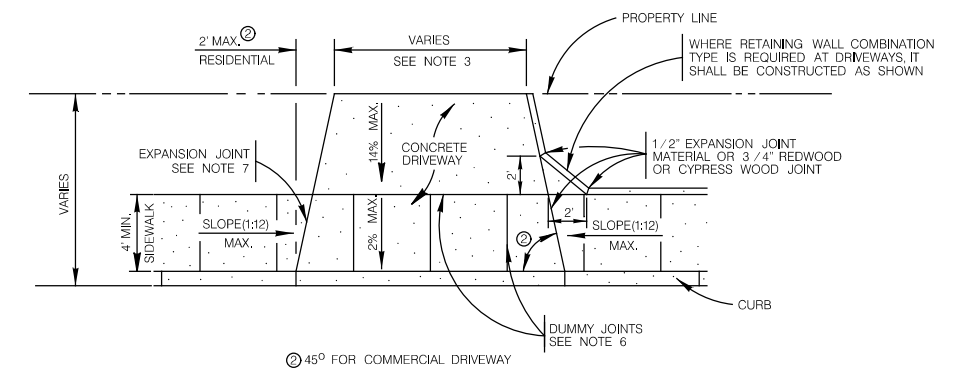

TYPICAL DRIVEWAY PLAN VIEW
WITH SIDEWALK ABUTTING CURB

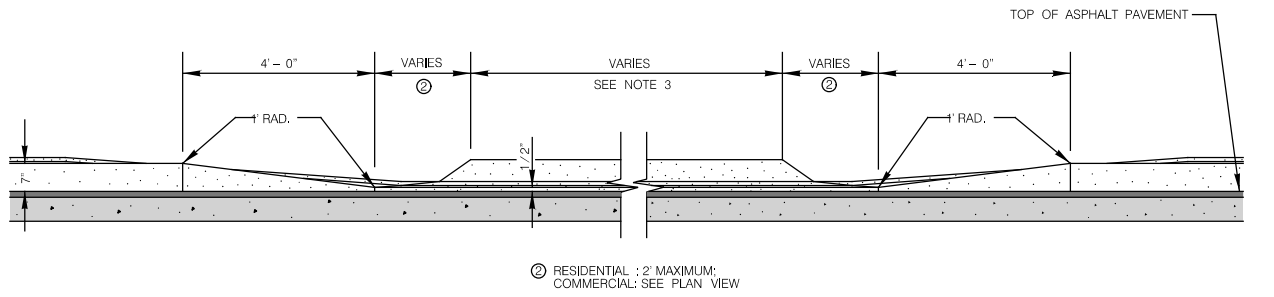

CURB PROFILE AT DRIVEWAY
WITH SIDEWALK SEPARATED FROM CURB

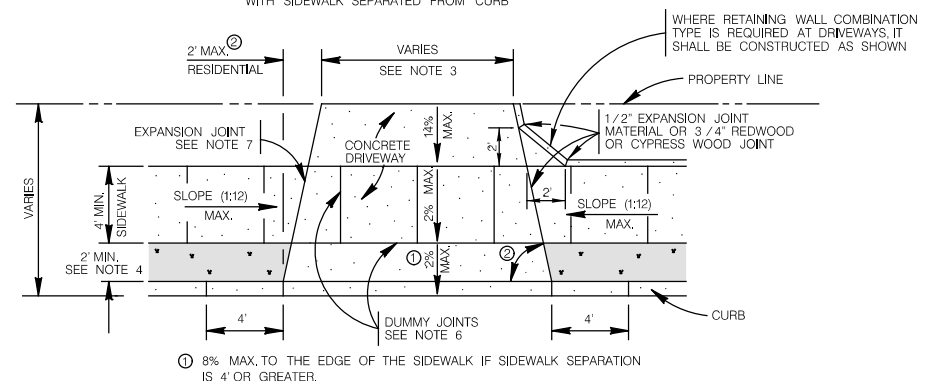

TYPICAL DRIVEWAY PLAN VIEW
WITH SIDEWALK SEPARATED FROM CURB

REV. NO.	DESCRIPTION	DATE
1	BASE / REINFORCEMENT MODIFICATIONS	7/7/17

MAY 2009

CITY OF SAN ANTONIO
CAPITAL IMPROVEMENTS MANAGEMENT SERVICES DEPARTMENT

CONCRETE DRIVEWAY STANDARDS

% SUBMITTAL	PROJECT NO.:	DATE:
DRWN. BY: V. VASQUEZ	DSGN. BY:	CHKD. BY: R.S. HOSSEINI, P.E.
		SHEET NO. OF

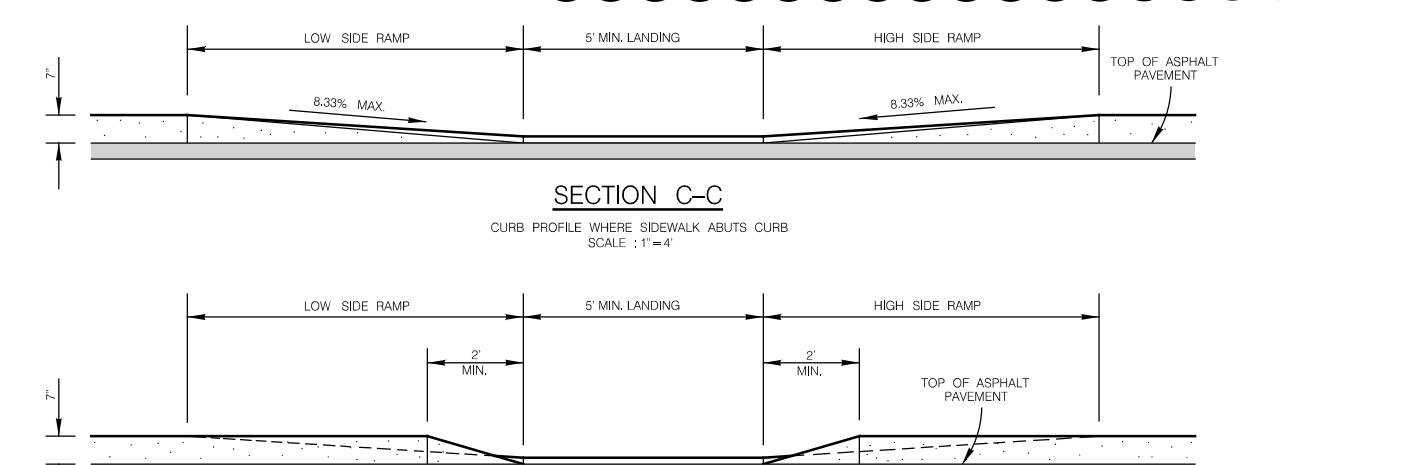
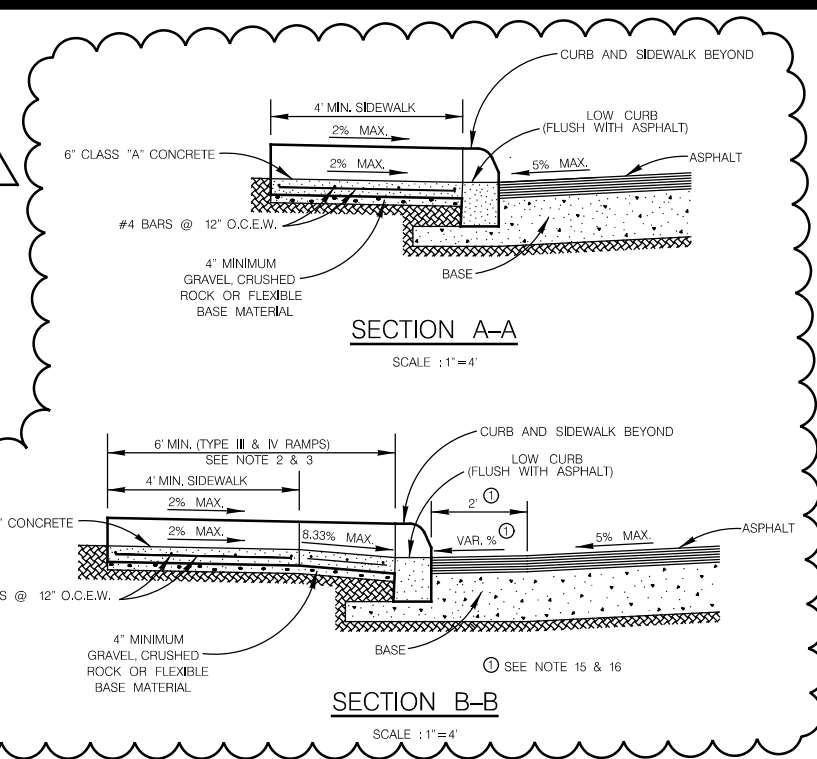
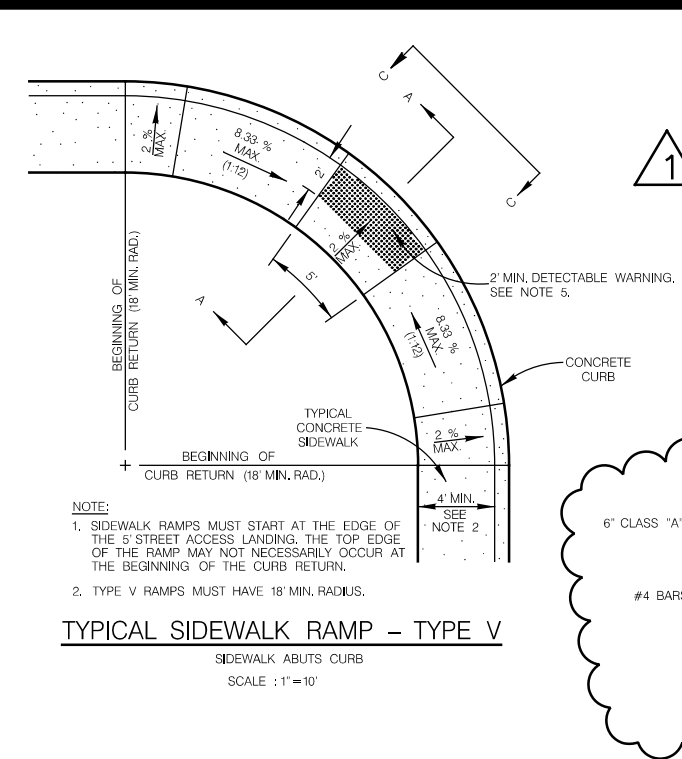
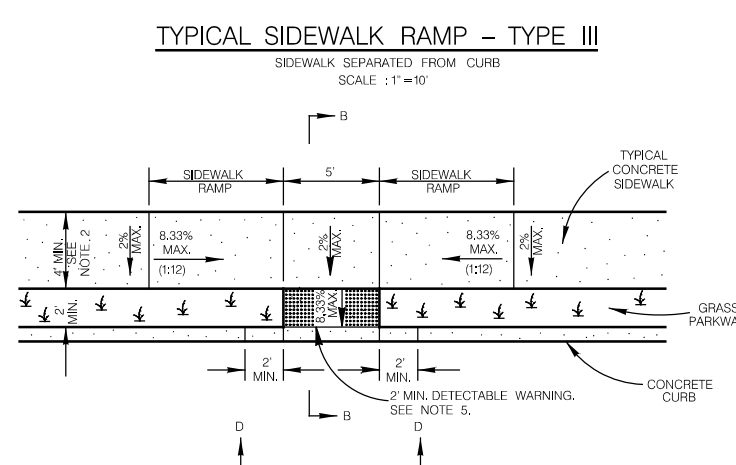
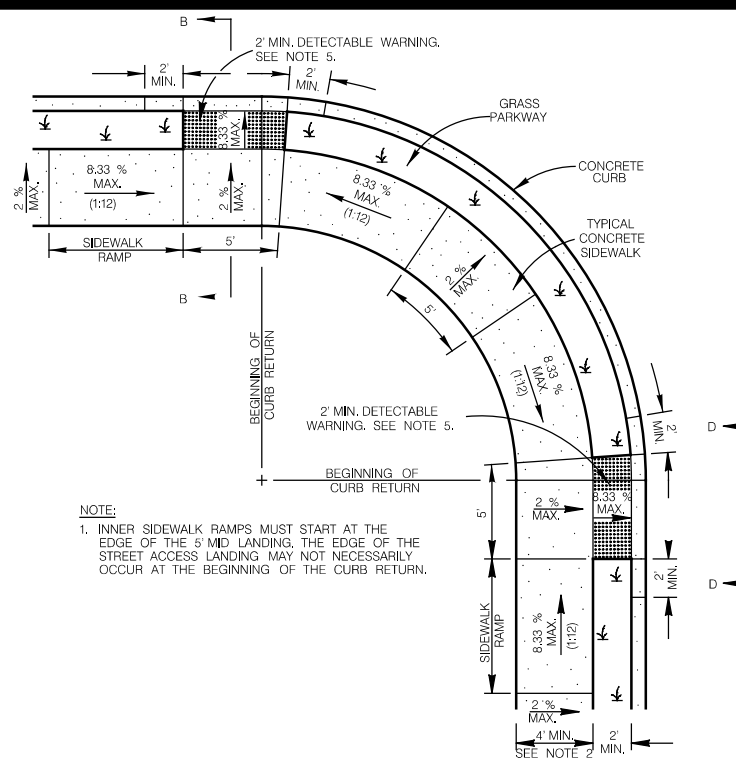
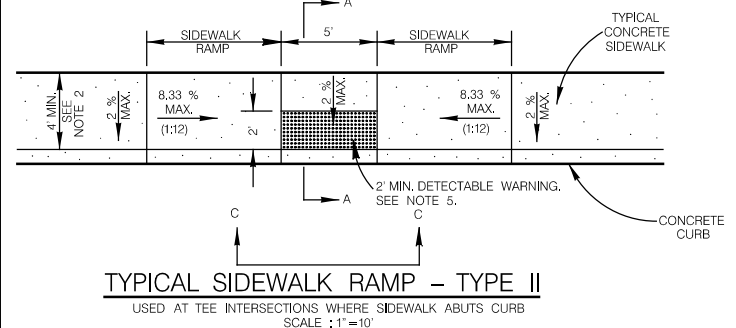
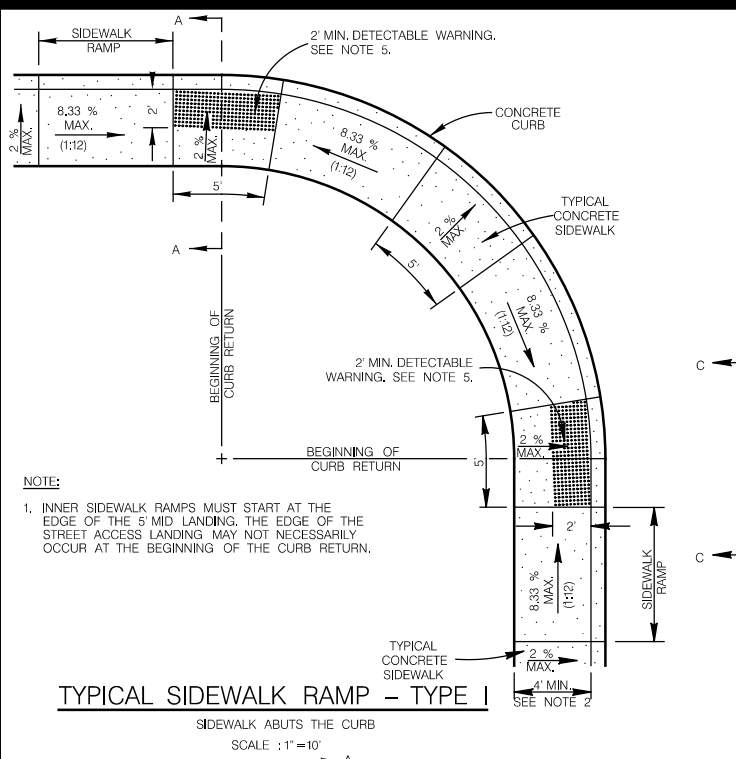

- GENERAL NOTES**
- WHEN POSSIBLE SIDEWALKS SHOULD BE PLACED NEXT TO THE PROPERTY LINE, ALLOWING A MINIMUM OF 1 FOOT BUFFER. DEVIATION OF THE PATHWAY FROM A STRAIGHT LINE IS ENCOURAGED TO AVOID TREES OR OTHER OBSTRUCTIONS.
 - FOR LOCAL TYPE "A" STREETS, SIDEWALKS SHALL HAVE A MINIMUM UNOBSTRUCTED WIDTH OF 4' AND IF SEPARATED FROM THE CURB, THE SIDEWALK SHALL BE LOCATED A MINIMUM OF 2' FROM THE BACK OF CURB.
 - FOR OTHER THAN LOCAL TYPE "A" STREETS, SIDEWALKS SHALL HAVE A MINIMUM UNOBSTRUCTED WIDTH OF 4' AND SEPARATED A MINIMUM OF 2' FROM THE BACK OF CURB OR AS AN OPTION, THE SIDEWALK SHALL HAVE A MINIMUM WIDTH OF 6' WHEN LOCATED AT THE BACK OF CURB.
 - SIDEWALK RAMP LENGTHS PRESENTED IN TABLE 1 ARE GUIDELINES ONLY. SIDEWALK RAMP LENGTHS SHALL BE OF SUFFICIENT LENGTH TO MAINTAIN 8.33% (1:12) MAXIMUM SLOPE.
 - ALL CURB-RAMPS OR LANDINGS ABUTTING THE CROSSWALK SHALL HAVE A DETECTABLE WARNING 24 INCHES DEEP (IN THE DIRECTION OF PEDESTRIAN TRAVEL) AND EXTENDING THE FULL WIDTH OF THE CURB RAMP OR LANDING. THE DETECTABLE WARNING SHALL CONSIST OF RAISED TRUNCATED DOMES, ALIGNED IN A GRID PATTERN WITH A DIAMETER OF A NOMINAL 0.9 INCHES (23 MM) A HEIGHT OF NOMINAL 0.2 INCHES (5 MM) AND A CENTER-TO-CENTER SPACING OF NOMINAL 2.35 INCHES (60 MM). THE DETECTABLE WARNING SURFACE SHALL BE A CAST-IN-PLACE TILE CONFORMING TO THE CITY OF SAN ANTONIO STANDARD SPECIFICATIONS.
 - DETECTABLE WARNINGS SHALL CONTRAST VISUALLY WITH ADJOINING SURFACES, EITHER LIGHT-ON-DARK, OR DARK-ON-LIGHT. THE MATERIAL USED TO PROVIDE CONTRAST SHALL BE AN INTEGRAL PART OF THE WALKING SURFACE.
 - SIDEWALK RAMP TYPE V SHALL BE USED ONLY WHERE THERE IS SIGNIFICANT RESTRICTION WITHIN THE PARKWAY TO CONSTRUCT TYPE I OR TYPE III RAMPS.
 - CONSTRUCTION OF ALL WHEELCHAIR RAMPS TO BE INCLUDED UNDER ITEMS "500 - CONCRETE CURB, GUTTER, AND CONCRETE CURB AND GUTTER" AND /OR "502 - CONCRETE SIDEWALKS". RAMP SURFACE SHALL BE BRUSH FINISHED.
 - THESE DETAILS ARE FOR REFERENCE ONLY. ACTUAL LOCATIONS OF WHEELCHAIR RAMPS TO BE SHOWN ON CONSTRUCTION PLANS. CITY CONSTRUCTION INSPECTOR CAN ADJUST LOCATIONS FOR SAFETY OR UTILITY CLEARANCE.
 - SIDEWALKS LESS THAN 5 FEET IN WIDTH SHALL BE PROVIDED WITH A PASSING SPACE AT A MAXIMUM SPACING OF 200 FEET.
 - WHEELCHAIR RAMP SHALL BE CONSTRUCTED WITH 6" CLASS "A" CONCRETE AND 4" MINIMUM GRAVEL, CRUSHED ROCK OR FLEXIBLE BASE MATERIAL.
 - REINFORCING STEEL SHALL BE #4 BARS AT 12" O.C.E.W.
 - SIDEWALK GRADES SHALL NOT EXCEED THE GRADE ESTABLISHED FOR THE ADJACENT ROADWAY. ANY SIDEWALK CONSTRUCTION THAT DEVIATES FROM THE NATURAL GRADE OF THE ROADWAY TO CREATE A GRADE STEEPER THAN THE EXISTING ROADWAY WILL REQUIRE RAMPS, HANDRAILS AND RESTING PLATFORMS TO BE CONSTRUCTED IN ACCORDANCE WITH ADA AND TAS STANDARDS.
 - SIDEWALK CROSS GRADE SHALL HAVE A MAXIMUM SLOPE OF 2%. LANDINGS SHALL HAVE A MAXIMUM SLOPE OF 2% IN ANY DIRECTION.
 - THE CHANGE OF GRADE BETWEEN ADJACENT SURFACES SHALL BE LESS THAN 11%. THE CHANGE OF GRADE SHALL BE DEFINED AS THE ALGEBRAIC DIFFERENCE OF THE ADJACENT SURFACE SLOPES. IN THE CASE OF A STREET ACCESS RAMP DESIGNED AT THE 8.33% MAXIMUM SLOPE, THE ADJACENT PAVEMENT CROSS SLOPE SHALL BE LESS THAN 2.67% (I.E. 8.33-(2.67)=11). IN ADDITION, THE ADJACENT PAVEMENT CROSS SLOPE SHALL BE LESS THAN OR EQUAL TO 5%.
 - IF THE CHANGE OF GRADE BETWEEN ADJACENT SURFACES IS GREATER THAN OR EQUAL TO 11%, A LEVELING STRIP, 2 FEET IN LENGTH, SHALL BE PROVIDED TO TRANSITION THE ADJACENT SURFACES.
 - ADA COMPLIANCE IN ALTERATIONS INCLUDE ONLY THAT WORK WITHIN THE LIMITS, BOUNDARIES OR SCOPE OF A PLANNED PROJECT.

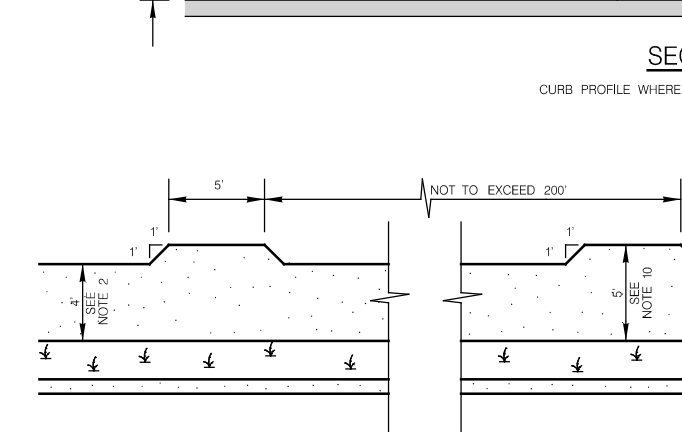
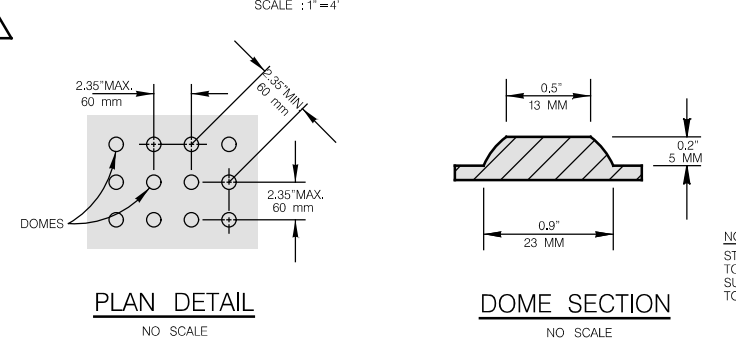
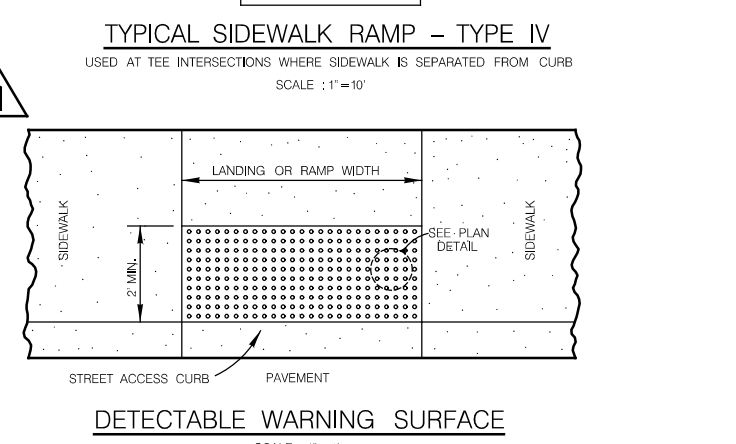
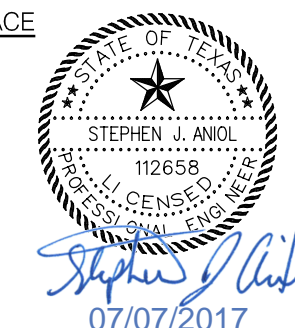

TABLE 1
(SEE NOTE 4)

GUTTER SLOPE	SIDEWALK RAMP LENGTH (1:12)	
	LOW SIDE	HIGH SIDE
1%	5'-6"	7'-2"
2%	5'-0"	8'-4"
3%	4'-6"	10'-0"
4%	4'-2"	12'-6"
5%	3'-10"	16'-8"

REV. NO.	DESCRIPTION	DATE
1	Wheelchair Ramp Requirements	7/7/17



MAY 2009

CITY OF SAN ANTONIO
CAPITAL IMPROVEMENTS MANAGEMENT SERVICES DEPARTMENT

WHEELCHAIR RAMP STANDARDS

% SUBMITTAL	PROJECT NO.:	DATE:
DRWN. BY: V. VASQUEZ	DSGN. BY:	CHKD. BY: R.S. HOSSEINI, P.E.
SHEET NO.:		OF

GENERAL NOTES

1. ALL CONCRETE SHALL TEST 4,000 P.S.I. AT 28 DAYS.
2. BUS STOP CONCRETE PAD CONSTRUCTION SHALL BE PAID UNDER ITEM 209 AT THE UNIT PRICE BID, WHICH PRICE SHALL BE FULL COMPENSATION FOR ALL DEMOLITION, REMOVAL OF EXISTING CURB, EXCAVATION, HAULING, CRUSHED LIMESTONE, REINFORCING STEEL, CONCRETE, CONCRETE CURB, JOINTS, AND INCIDENTALS NECESSARY TO COMPLETE THE WORK.
3. BUS PAD AND CURB SHALL BE MONOLITHICALLY POURED. ALL EXISTING CURBING SHALL BE REMOVED AND REPLACED AS PER STANDARD DETAILS.
4. THE CONTRACTOR SHALL CONSTRUCT AN EXPANSION JOINT MIDWAY IF THE "CONCRETE BUS STOP PAD" IS LONGER THAN 150 FEET. NO DIRECT PAYMENT SHALL BE MADE FOR CONSTRUCTION OF AN EXPANSION JOINT.
5. ACTUAL BUS PAD LENGTH AND WIDTH TO BE FIELD DETERMINED BY CITY ENGINEER OR HIS DESIGNATED REPRESENTATIVE.
6. DO NOT DRIVE ON PAD UNTIL CONCRETE HAS REACHED A STRENGTH OF 2,800 P.S.I.
7. BREAK TEST CYLINDERS AS FOLLOWS:
 2 AT 3 DAYS
 2 AT 7 DAYS
 2 AT 28 DAYS
8. CONCRETE BUS PAD LENGTH (OR AS SHOWN ON THE PLANS):
 30 M.P.H. - 100'
 35 M.P.H. - 160'
 40 M.P.H. - 160'
 45 M.P.H. - 200'

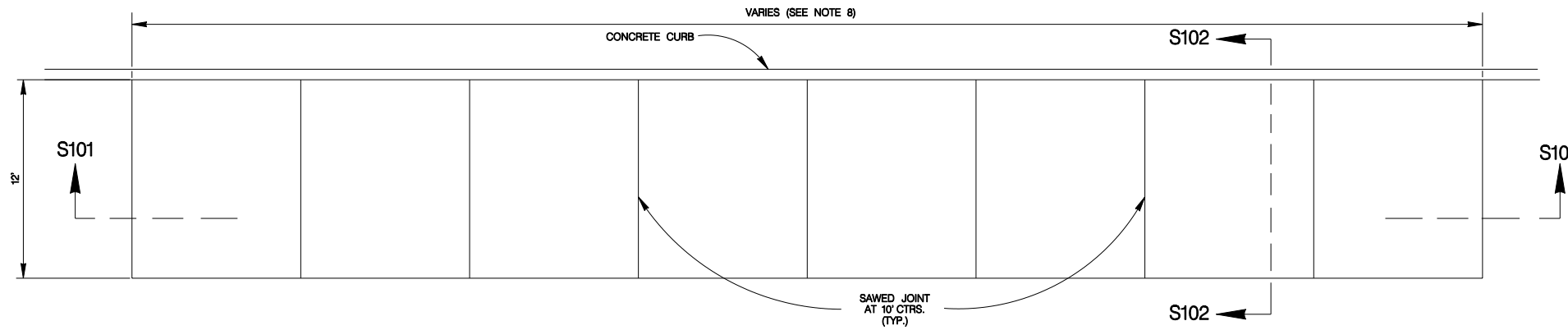

PLAN VIEW
NTS

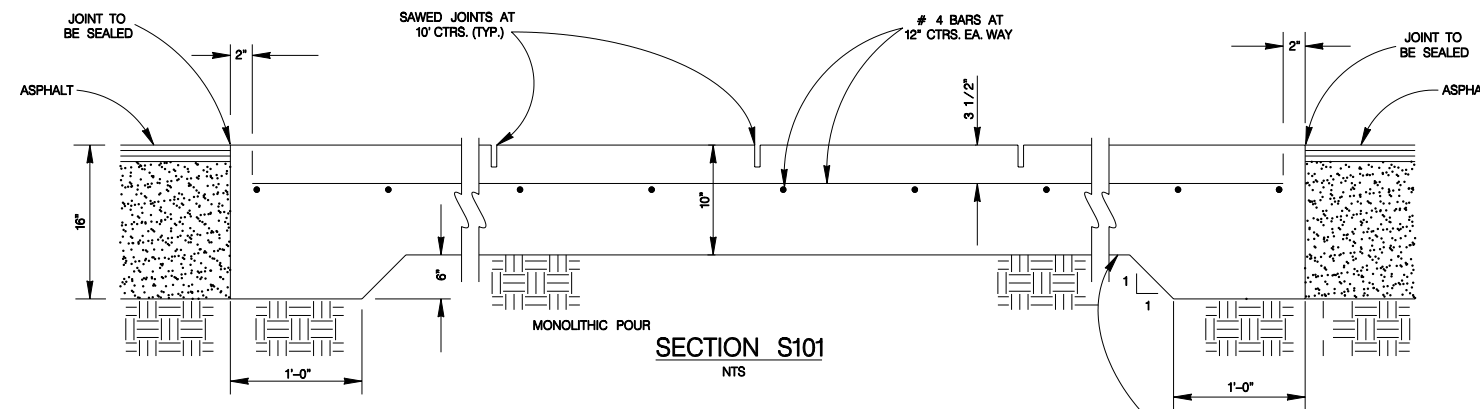

SECTION S101
NTS

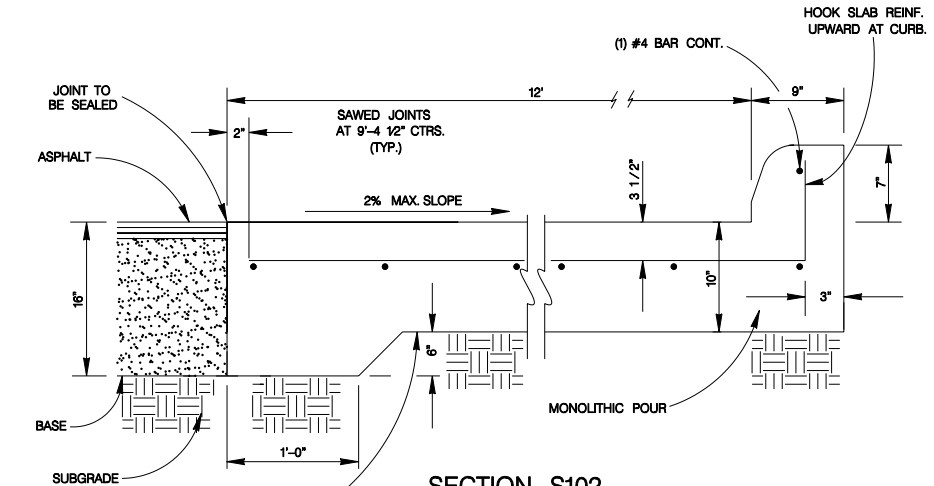

SECTION S102
NTS

SAWCUT AS SOON AS THE CONCRETE IS STRONG ENOUGH TO SUPPORT THE SAWING EQUIPMENT AND TO PREVENT AGGREGATE RAVELING DURING THE SAWING OPERATION. ALL JOINTS SHOULD BE SAW CUT WITHIN 12 HOURS OF THE CONCRETE'S PLACEMENT. JOINTS SHALL BE FILLED WITH AN APPROVED ELASTIC TYPE MATERIAL AFTER SAW CUTTING.

PROOFROLL EXISTING SUBGRADE WITH BACKHOE OR SIMILAR EQUIPMENT TO LOCATE POTENTIAL SOFT REGIONS OF SUBGRADE. REPLACE SOFT AREAS WITH 12" OF SUITABLE MATERIAL.

REMOVE AND REPLACE EXISTING ASPHALT PAVEMENT WITH 1 1/2" TYPE D HMAP. NO DIRECT PAYMENT WILL BE MADE FOR SUCH REPAIRS.

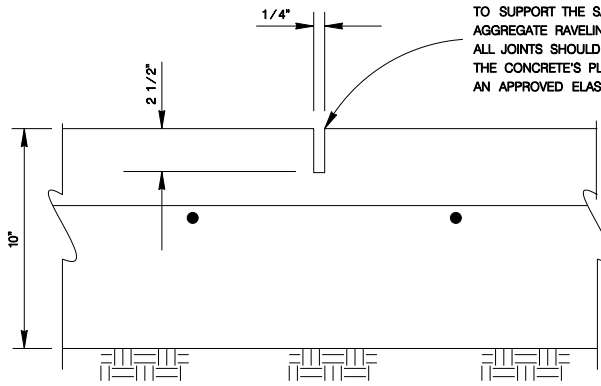

SAWED JOINT DETAIL
NTS

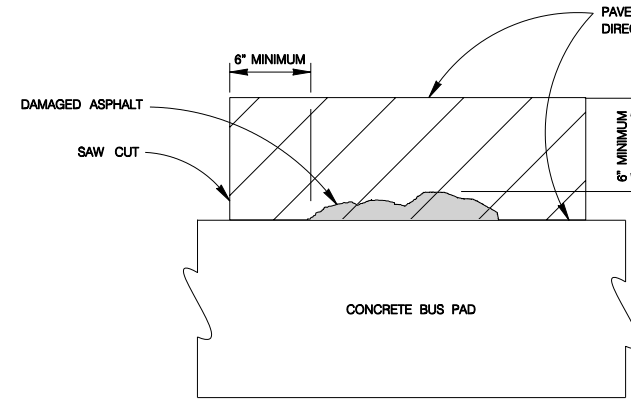

REPAIR OF DAMAGED ASPHALT
NTS

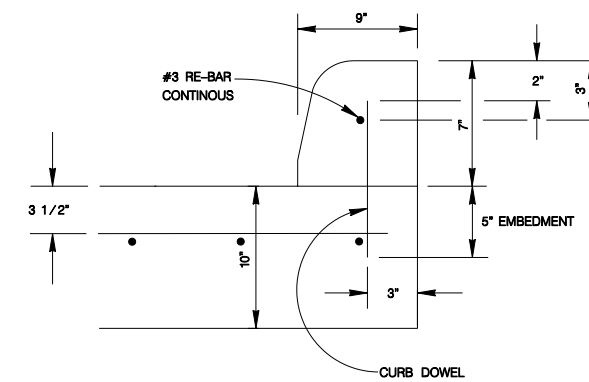

CONCRETE CURB OPTION
NEED CITY ENGINEER'S APPROVAL
NTS

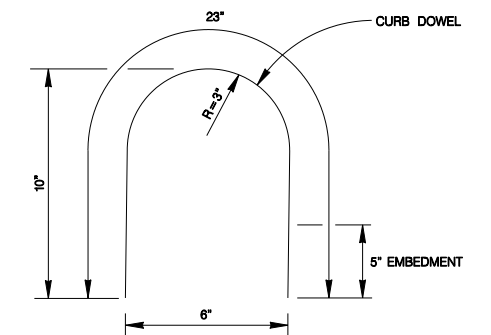

CURB DOWEL
NO. 3 RE-BAR @ 30" C-C
NTS

NOTE:
THE CONTRACTOR SHALL CONSTRUCT AN EXPANSION JOINT MIDWAY IF THE "CONCRETE BUS STOP PAD" IS LONGER THAN 150 FEET. NO DIRECT PAYMENT SHALL BE MADE FOR CONSTRUCTION OF AN EXPANSION JOINT.

EXPANSION JOINT DETAIL
SCALE : 1" = 1'

MAY 2009

CITY OF SAN ANTONIO
CAPITAL IMPROVEMENTS MANAGEMENT SERVICES DEPARTMENT

**CONCRETE
BUS STOP PAD**

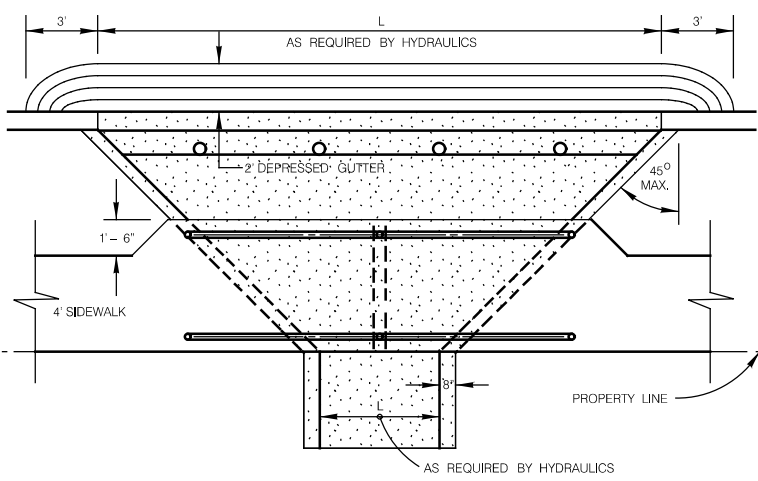

PLAN VIEW "A"
SCALE : 1" = 8'

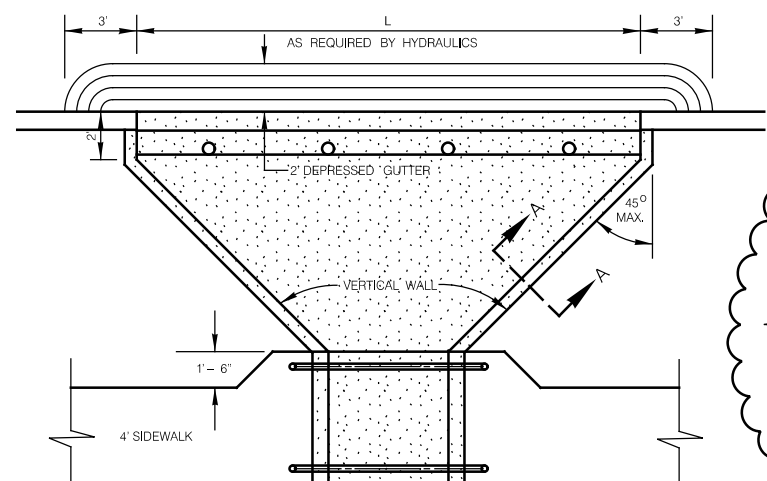

PLAN VIEW "B"
SCALE : 1" = 8'

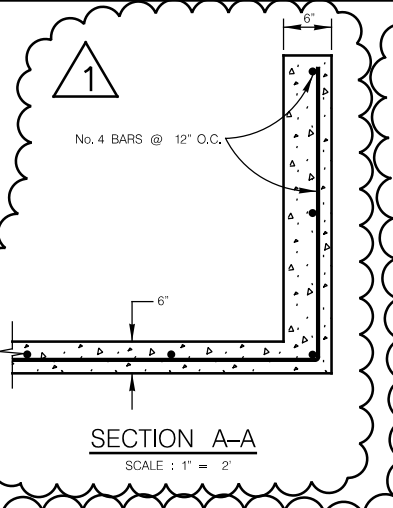

SECTION A-A
SCALE : 1" = 2'

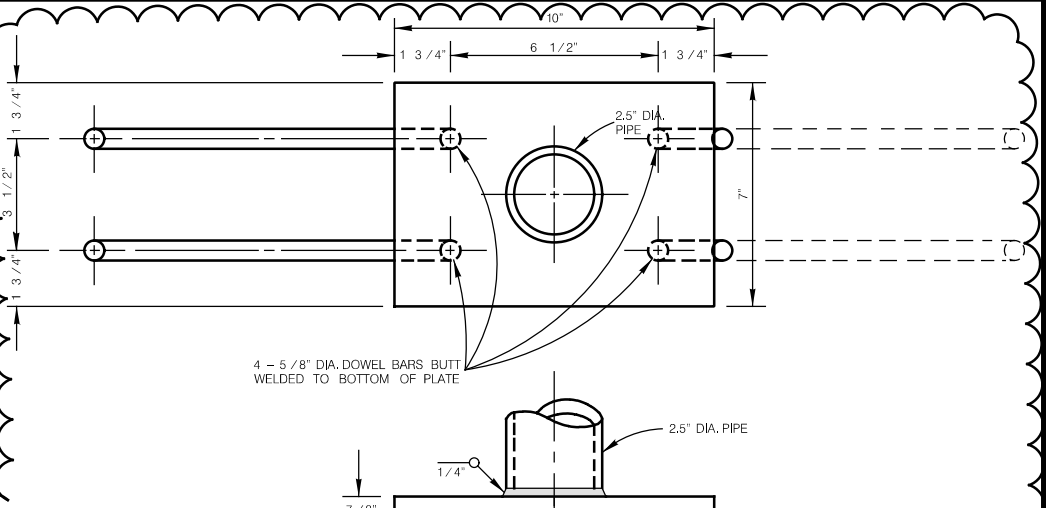

PIPE ANCHORAGE DETAILS
SCALE : 1" = 6"

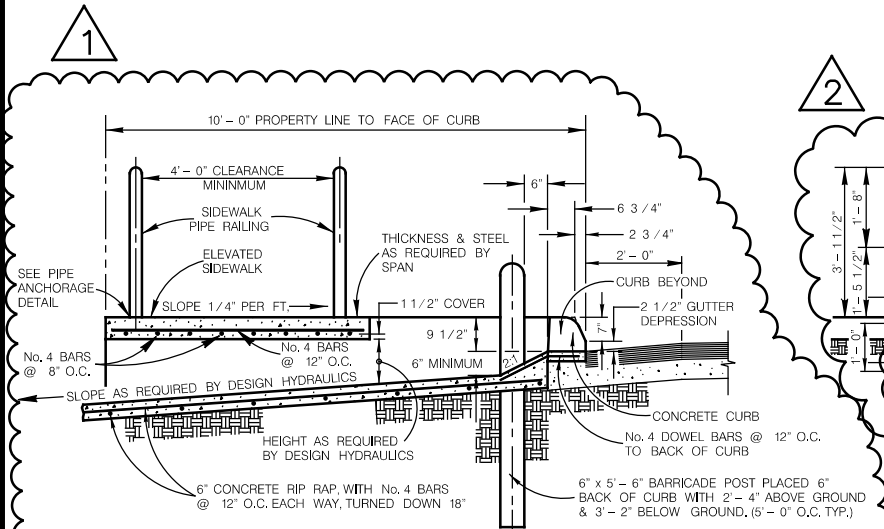

**ELEVATED SIDEWALK & DROP CURB
DETAILS FOR DRAINAGE CHANNELS**
SCALE : 1" = 4'

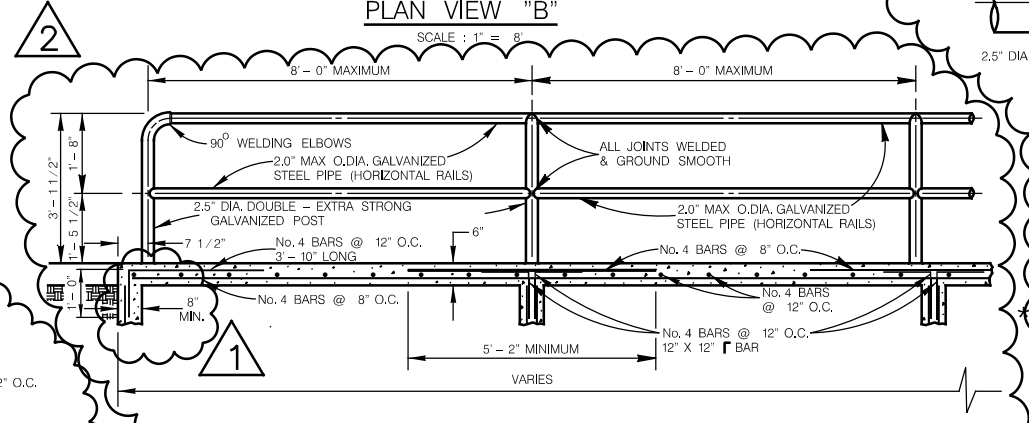

**TYPICAL SIDEWALK BRIDGE &
SIDEWALK PIPE RAILING SECTION**
SCALE : 1" = 4'

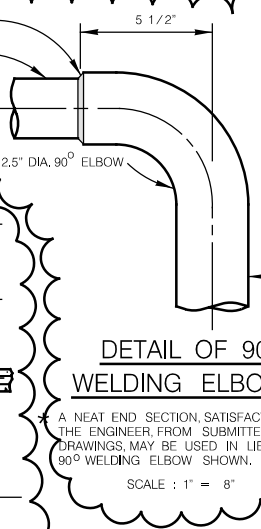

**DETAIL OF 90°
WELDING ELBOWS**
SCALE : 1" = 8"

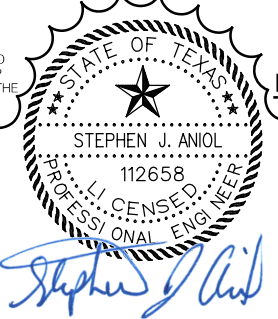

REV. NO.	DESCRIPTION	DATE
1	Concrete/Reinforcement Modifications	7/7/17
2	Pipe Railing Modifications	7/7/17

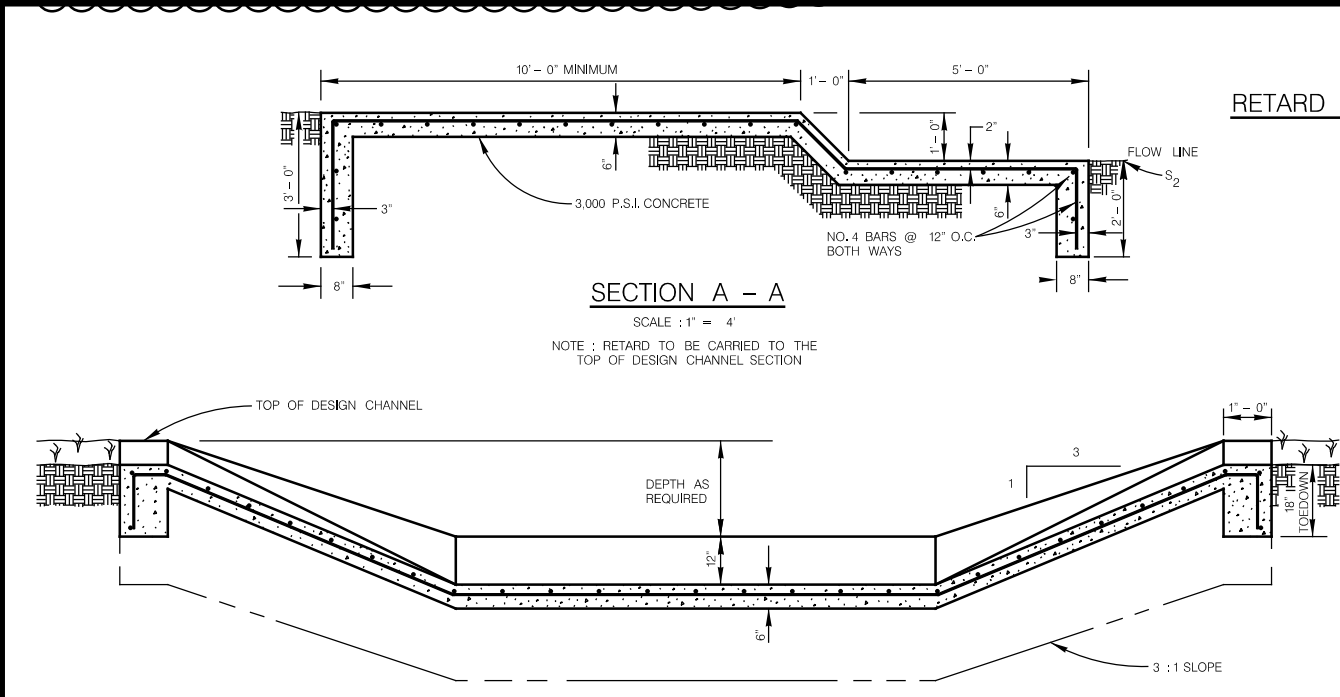

SECTION A - A
SCALE : 1" = 4'

SECTION B - B
SCALE : 1" = 4'

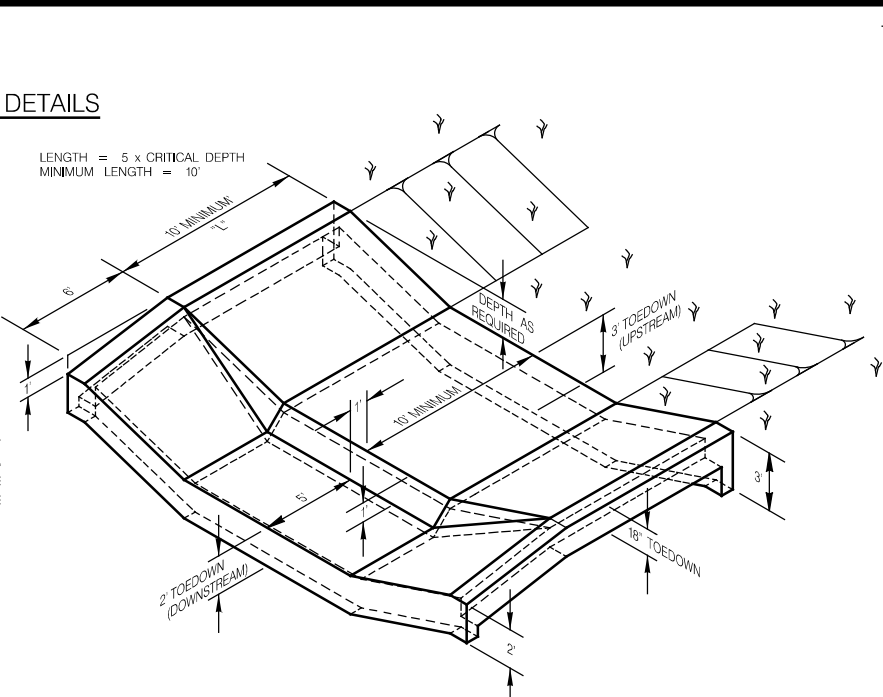

ISOMETRIC VIEW
SCALE : 1" = 10'

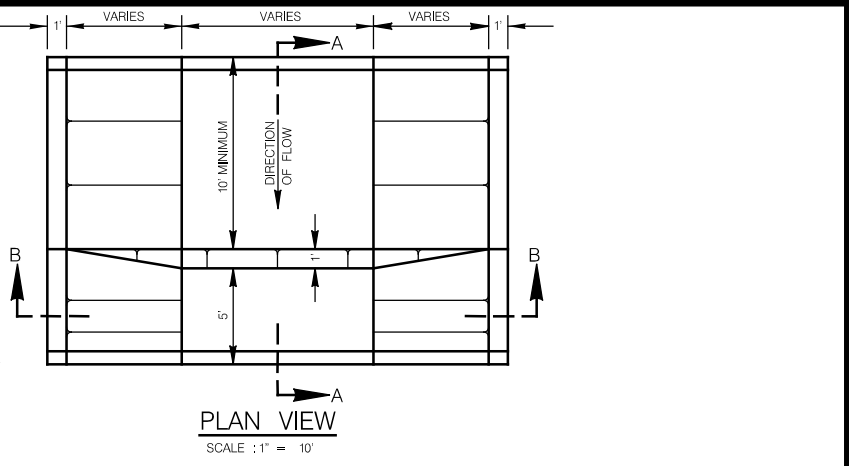

PLAN VIEW
SCALE : 1" = 10'

JANUARY 2005
CITY OF SAN ANTONIO
CAPITAL IMPROVEMENTS MANAGEMENT SERVICES DEPARTMENT

**ELEVATED SIDEWALK & RETARD
STANDARDS**

% SUBMITTAL	PROJECT NO.:	DATE:
DRWN. BY: V. VASQUEZ	DSGN. BY:	CHKD. BY:
		SHEET NO. OF