

SQUARE DEAL 'B'

Instruction Manual

Version 4.5

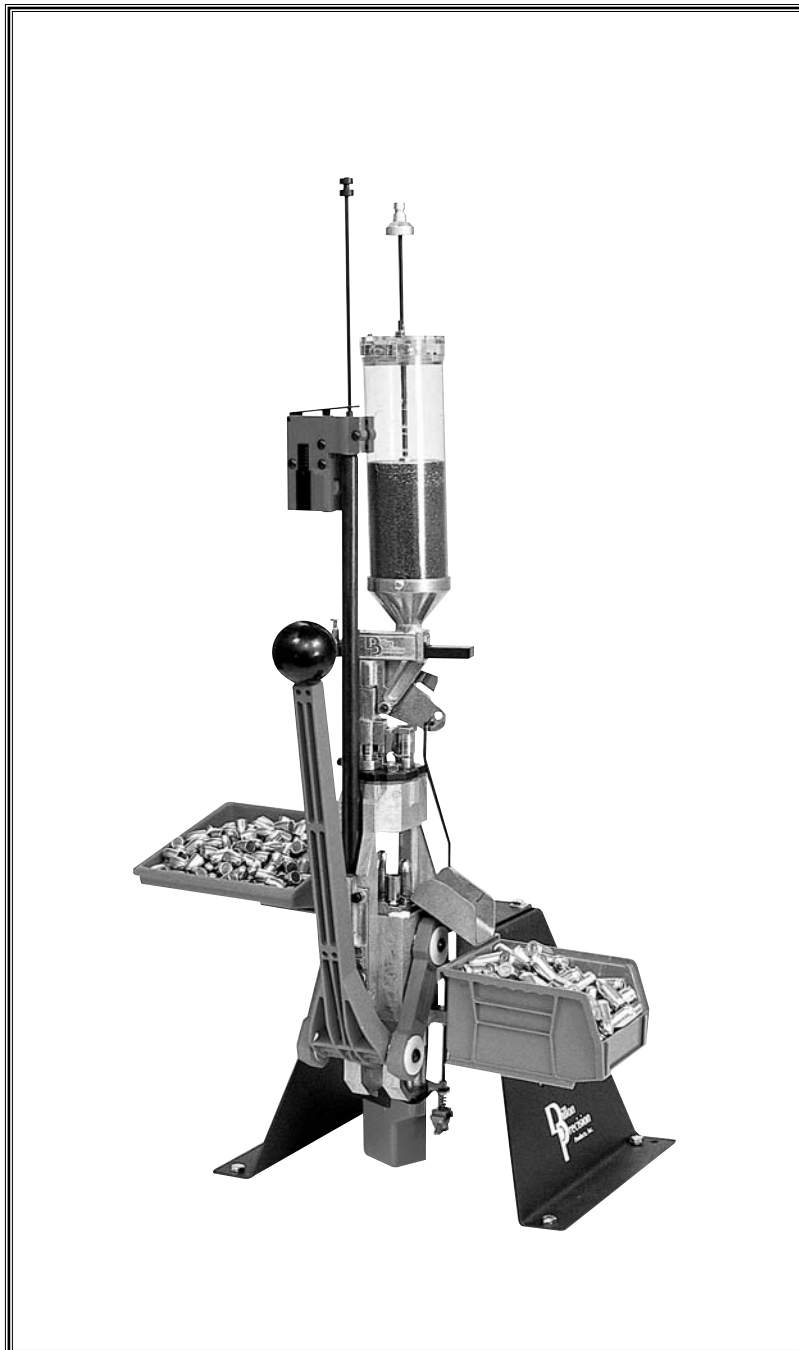

Square Deal B Parts List

Stock #	Description	Stock #	Description
11628	Bullet Seater Insert	13860	Base Disc Screws
11734	Crimp Insert	13864	Switch Lever
*12124	Seating Stem	13865	Powder Die
12864	Carbide Sizer Insert	13871	Bellcrank Cube
13028	Square Deal B Manual	13879	Primer Magazine – Small
13328	Shellplate Bolt	13882	Powder Measure Lid
13355	Return Bracket	13893	Powder Bar Post – Large
*13427	Powder Funnel	13895	Clamp Screw
13429	Decap Pin Nut	13896	1/4-20 3/8 BH Screw
13433	Ejector Wire	13908	Crimp Adjustment Screw
13437	Shaft	13921	Powder Measure Spacer Plug
13444	Overtravel Block Bolt	13943	Powder Bar Adjustment Bolt
13445	Square Deal Frame	13944	Indexer Return Spring
13461	Index Bolt	13945	Pivot Bolt Wave Washer
13479	Spent Primer Track Cover	13951	Powder Bar Post – Small
*13504	Shellplate	13957	Primer Shield Cap
13594	Spent Primer Chute	13958	Powder Bar Washer
13597	Over Travel Block	13961	Primer Adjustment Screw
13621	Primer Cup – Large	13964	Spring Screw
13622	Crank Pin	13967	Primer Punch – Large
13624	Indexer Spring (RL1000)	13976	Chute Bracket Screw
13644	Smaller Powder Bar Spacer	13979	Primer Return Pin Spring
13651	Spent Primer Cup	13982	Primer Punch Spring
13657	Primer Cup – Small	13986	Collar Clamp
13659	Chute Bracket	13989	Feed Body Screw
13673	Primer Magazine – Large	13999	Pickup Tube Tip (yellow) - Small
13689	Primer Slide Roller	14003	Magazine Orifice (red) - Large
13690	Platform Base Disc	14010	Pickup Tube Tip (green) - Large
13691	Powder Measure Tube	14013	Roller Bracket Screw
13705	Indexer Pawl	14014	10-24x7/8 SHCS
13707	Follower Rod	14019	Detent Ball
13712	Toolhead Plate	14024	Magazine Orifice (blue) - Small
13714	Indexer Lever	14033	Primer Cup Spring (RL550B)
13718	Crank Pin Set Screw	14036	Powder Bar Spring
13721	Delrin Die Lock/Friction Plate	14037	Clamp/Bracket Screw
13722	Primer Slide Bearing	14040	Retaining Clip
13726	Return Spring Roll Pin	14041	Bowed Washer
13739	Detent Spring	14051	Primer Retaining Pin
13754	Primer Slide	*14060	Locator Button (3)
13756	Bin Box	14157	#10 Washer
13757	Primer Punch – Small	14293	Indexer Lever Assembly
13764	Powder Die Clamp	16523	Plastic Wave Bearing - 4 pack
13776	Pawl Pin	16814	Failsafe Rod
13789	Set Screw	17085	Dispensing Tip, Large
13790	Primer Slide Return Pin	17086	Dispensing Tip, Small
13793	Body Collar Roller	18077	Brass Link Arm Bearing
13797	Pivot Bushing	18077	Brass Linkarm Bearing
13798	Return Spring	18086	#10 Rod Washer
13799	Blue Failsafe Strip Nut	20059	Primer Pickup Tube – Small
13801	Tinnerman Insert	20060	Primer Pickup Tube – Large
13809	Roller Bolt	20114	Crank Handle
13815	Toolhead Mount Screw	20117	Powder Bar – Large
13818	Powder Bar Insert – Small	20118	Powder Bar – Small
13822	Link Arm	20261	Powder Measure Body
13823	Primer Punch Set Screw	20302	Complete Early Warning System
13828	Link Arm Washer	20642	Body Collar Assembly
13843	Upper Decap Pin	20900	Primer Feed Body
13845	Collar Sleeve	22200	Decap Stem w/ Cap & Pin
13847	Overtravel Spring		
13850	Handle Knob		
13853	Powder Bar Insert – Large		
13857	Battery Cover		

* Indicates a caliber/size specific part. See the caliber conversion chart for the caliber you are loading for.

Square Deal B Schematic

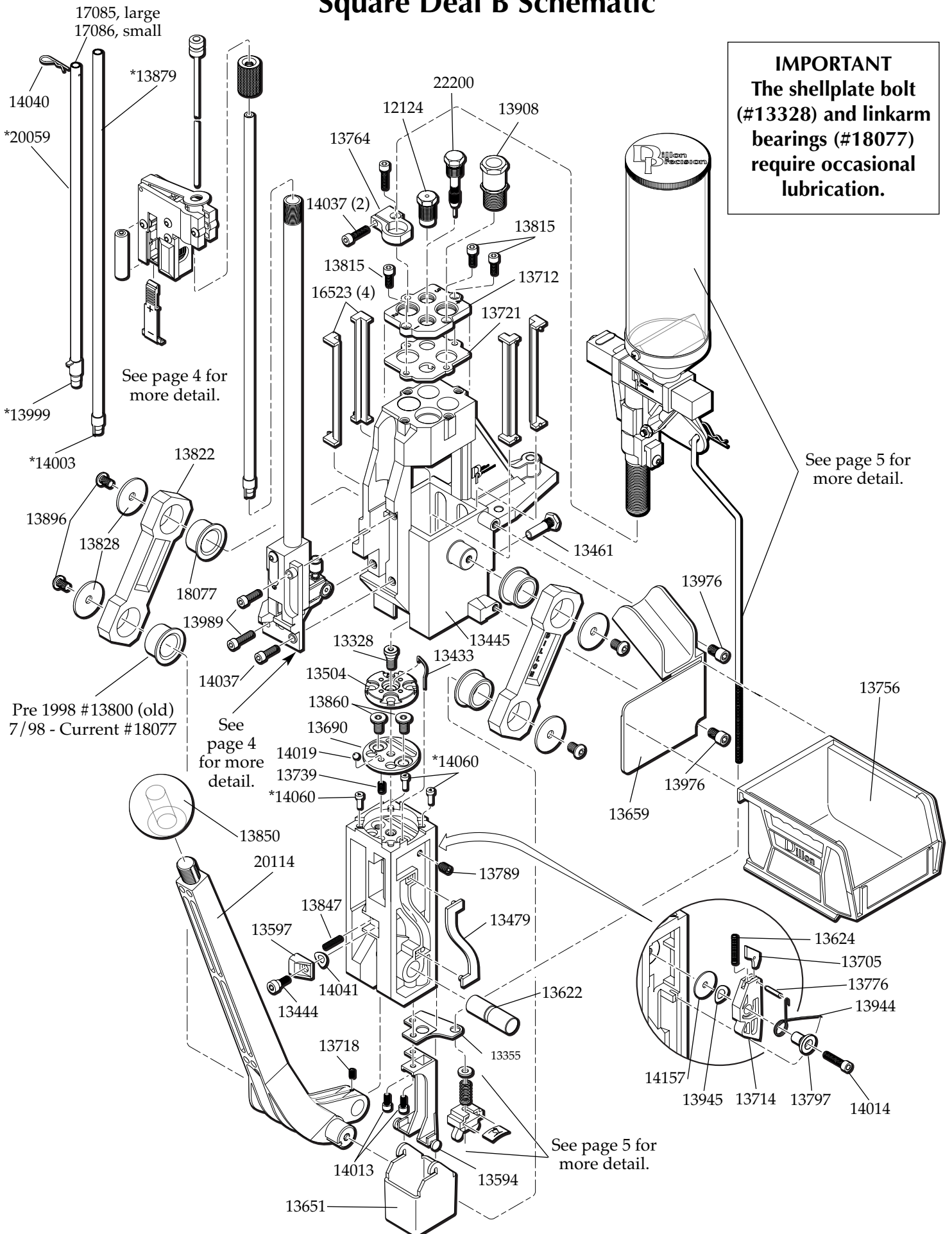

IMPORTANT
The shellplate bolt (#13328) and linkarm bearings (#18077) require occasional lubrication.

See page 5 for more detail.

See page 4 for more detail.

See page 5 for more detail.

Automatic Primer System

SDB Automatic Primer System 20253 Large – 20012 Small

- 13621 Primer Cup – Large
- 13657 Primer Cup – Small
- 13673 Primer Magazine – Large
- 13689 Primer Slide Roller
- 13722 Primer Slide Bearing
- 13726 Return Spring Roll Pin
- 13754 Primer Slide
- 13757 Primer Punch – Small
- 13790 Primer Slide Return Pin
- 13798 Return Spring
- 13809 Roller Bolt
- 13823 Primer Punch Set Screw
- 13957 Primer Shield Cap
- 13961a Primer Feed Adjustment Screw
- 13961b Slide Stop Adjustment Screw
- 13964 Spring Screw
- 13967 Primer Punch – Large
- 13979 Primer Return Pin Spring
- 13982 Primer Punch Spring
- 13989 Feed Body Screw
- 14037 Bracket Screw
- 14051 Primer Retaining Pin
- 20900 Primer Housing & Shield

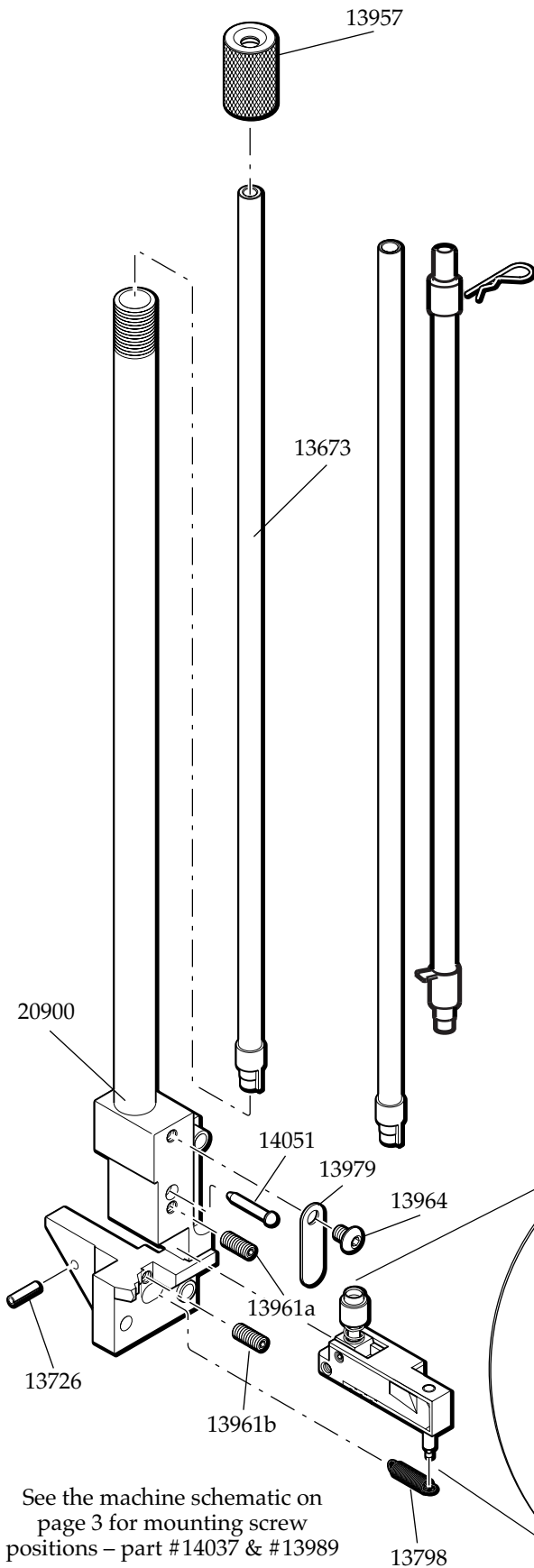

20302 Early Warning System (Complete)

- 13707 Follower Rod
- 13857 Battery Cover
- 13864 Switch Lever

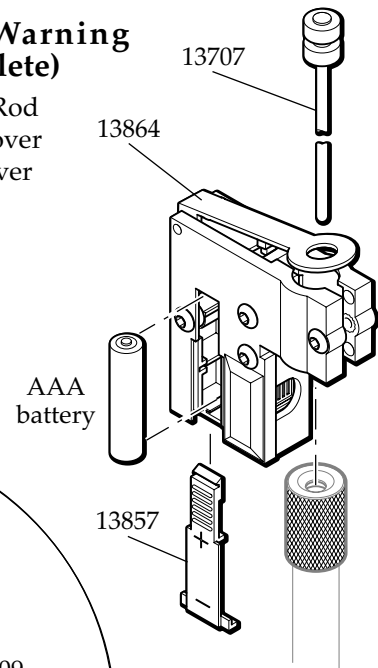

See the machine schematic on page 3 for mounting screw positions – part #14037 & #13989

Automatic Powder System

20001 SDB Automatic Powder System

- 13644 Powder Measure Spacer
- 13691 Powder Measure Tube
- *13782 Powder Funnel – Pistol
- 13793 Powder Measure Roller
- 13799 Stripper Wing Nut
- 13801 Tinnerman Insert
- 13818 Powder Bar Insert – Small
- 13845 Collar Sleeve
- 13848 Bellcrank Bushing
- 13853 Powder Bar Insert – Large
- 13865 Powder Die
- 13871 Bellcrank Cube
- 13882 Powder Measure Lid
- 13893 Powder Bar Post – Large
- 13895 Collar Clamp Screw
- 13904 10-32x1 1/4 SHCS Bellcrank Bolt
- 13921 Powder Measure Spacer Plug
- 13943 Powder Bar Adjustment Screw
- 13951 Powder Bar Post – Small
- 13958 Powder Bar Washer
- 13986 Collar Clamp
- 14023 8-32x3/4 BH Screw
- 14033 Rod Spring
- 14036 Powder Bar Spring
- 14041 Bowed Washer
- 14202 Powder Measure Tube Screws
- 14808 Collar Roller Bushing
- 16340 Nylon Lock Nut
- 16814 Failsafe Rod
- 20063 Powder Bar – Large
- 20062 Powder Bar – Small
- 20642 SDB Body Collar - assembly
- 20780 Powder Bar Assembly – Extra Small
- 21353 Powder Bar Assembly – Extra Large
- 22273 Powder Measure Body
- 97034 Slotted Bellcrank & Cube

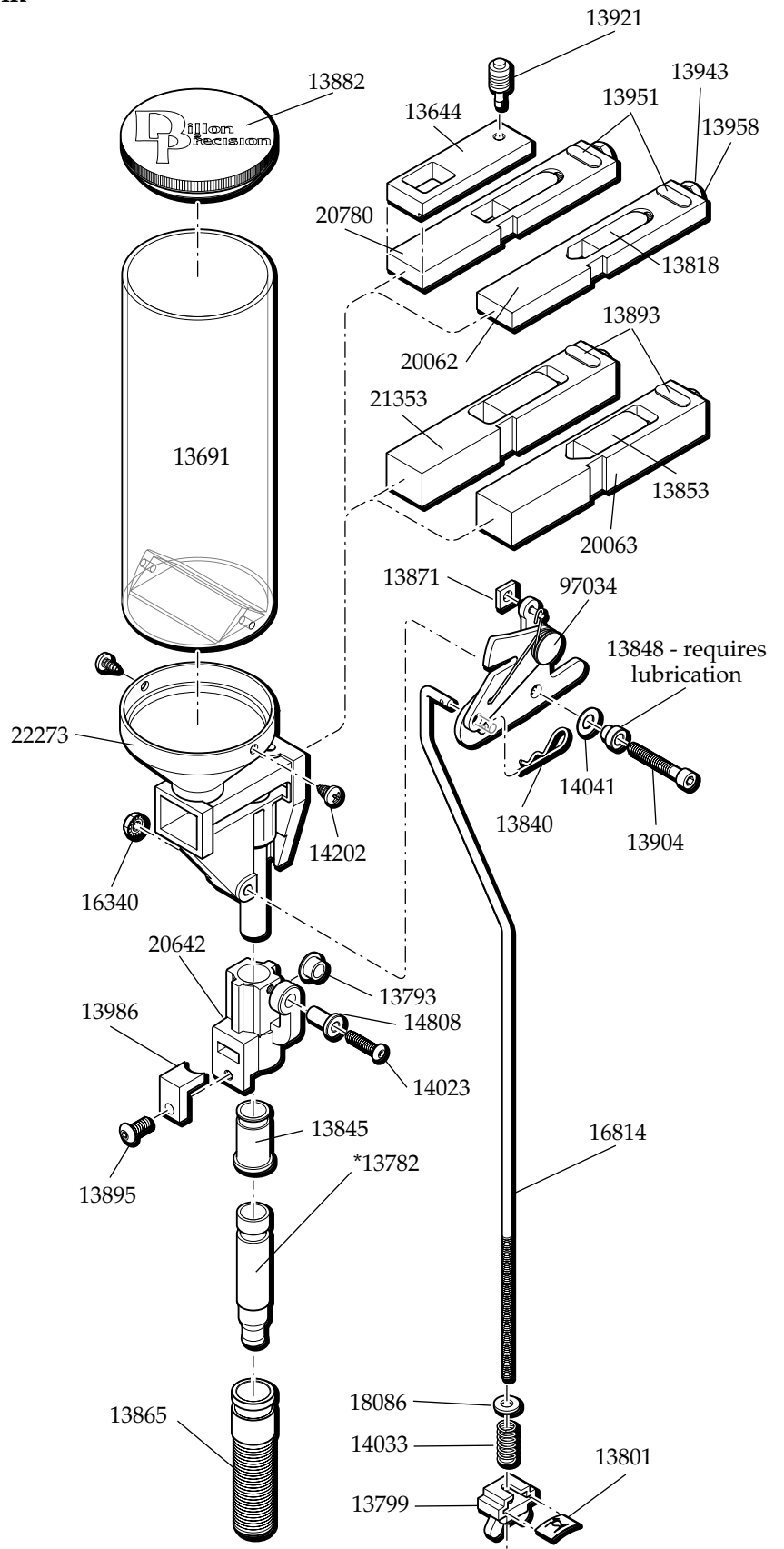

20304 Square Deal "B" Failsafe Kit

- 13355 Return Bracket
- 13799 Stripper Wing Nut
- 13801 Tinnerman Insert
- 13840 Throttle Clip
- 14033 Rod Spring
- 16814 Failsafe Return Rod
- 18086 Washer

Okay, It's Here; Now What?

First of all, the Square Deal "B" is a remarkably simple machine and a little care and thought now while you're setting it up will save you time and give you thousands of trouble free rounds.

Mandatory Safety Measures

Reloading ammunition involves the use of highly explosive primers and powder. Handling these materials is inherently dangerous. You should recognize this danger and take certain minimum precautions to lessen your exposure to injury.

Never operate the machine without ear and eye protection on. Call our customer service department at (800) 223-4570 for information on the wide variety of shooting/safety glasses and hearing protection that Dillon has to offer.

- **PAY ATTENTION:** Load only when you can give your complete attention to the loading process. Don't watch television or try to carry on a conversation and load at the same time. Watch the automatic systems operate and make sure they are functioning properly. If you are interrupted or must leave and come back to your loading, always inspect the cases at every station to insure that the proper operations have been accomplished.
- **SMOKING:** Do not smoke while reloading or allow anyone else to smoke in your reloading area. Do not allow open flames in reloading area.
- **SAFETY DEVICES:** Do not remove any safety devices from your machine or modify your machine in any way.
- **LEAD WARNING:** Be sure to have proper ventilation while handling lead components or when shooting lead bullets. Lead is known to cause birth defects, other reproductive harm and cancer. Wash your hands thoroughly after handling anything made of lead.
- **LOADS AND LENGTHS:** Avoid maximum loads and pressures at all times. Use only recommended loads from manuals and information supplied by reliable component manufacturers and suppliers. Since Dillon Precision has no control over the components which may be used on their equipment, no responsibility is implied or assumed for results obtained through the use of any such components.

Seat bullets as close to maximum cartridge length as possible. Under some conditions, seating bullets excessively deep can raise pressures to unsafe levels. Refer to a reliable loading manual for overall length (OAL).

- **QUALITY CHECKS:** Every 50-100 rounds, perform periodic quality control checks on the ammunition being produced. Check the amount of powder being dropped and primer supply.
- **RELOADING AREA:** Keep your components safely stored. Clear your work area of loose powder, primers and other flammables before loading.
- **COMPONENTS:** Never have more than one type of powder in your reloading area at a time. The risk of a mix-up is too great. Keep powder containers closed.

Be sure to inspect brass prior to reloading for flaws, cracks, splits or defects. Throw these cases away.

Keep components and ammunition out of reach of children.

- **BLACK POWDER:** Do not use black powder or black powder substitutes in any Dillon powder measure. Loading

black powder cartridges requires specialized loading equipment and techniques. Failure to do so can result in severe injury or death.

- **PRIMERS:** Never force primers. If they get stuck in the operation of the machine, disassemble it and gently remove the obstruction.

Never attempt to clear primers that are stuck in either the primer pickup tube or the primer magazine tube. Never, under any circumstances, insert any type of rod to attempt to force stuck primers out of these tubes. Trying to force primers out of the tube will cause the primers to explode causing serious injury or even death.

If primers get stuck in a primer magazine or pickup tube flood the tube with a penetrating oil (WD-40), throw the tube in the garbage and call us for a free replacement.

Never attempt to deprime live primers – eventually one will go off. When it does it will detonate the others in the spent primer cup. Depriming live primers is the single most dangerous thing you can do in reloading and can cause grave injury or death.

- **LOADED AMMUNITION:** Properly label all of your loaded ammunition (Date, Type of Bullet, Primer, Powder, Powder Charge, etc.).
 - **BE PATIENT:** Our loading equipment is conservatively rated and you should have no trouble achieving the published rates with a smooth, steady hand. If something doesn't seem right, stop, look and listen. If the problem or the solution isn't obvious, call us. The reloading bench is no place to get into a hurry.
- We have done everything we know how to make your machine as safe as possible. We cannot, however, guarantee your complete safety. To minimize your risk, use common sense when reloading and follow these basic rules.
- **REMEMBER:** If your machine does not perform to your expectations, or if you are having technical difficulties, give us a call.

Ready? Let's Set Up

Carefully remove your new Square Deal "B" from its packaging. Set the small parts aside.

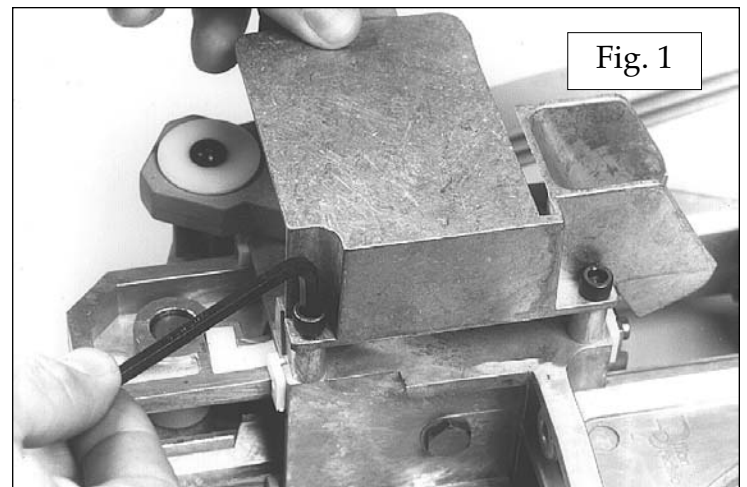

Fig. 1 – Install the ejected cartridge chute bracket (#13659) with two large screws (#13976) from the parts bag.

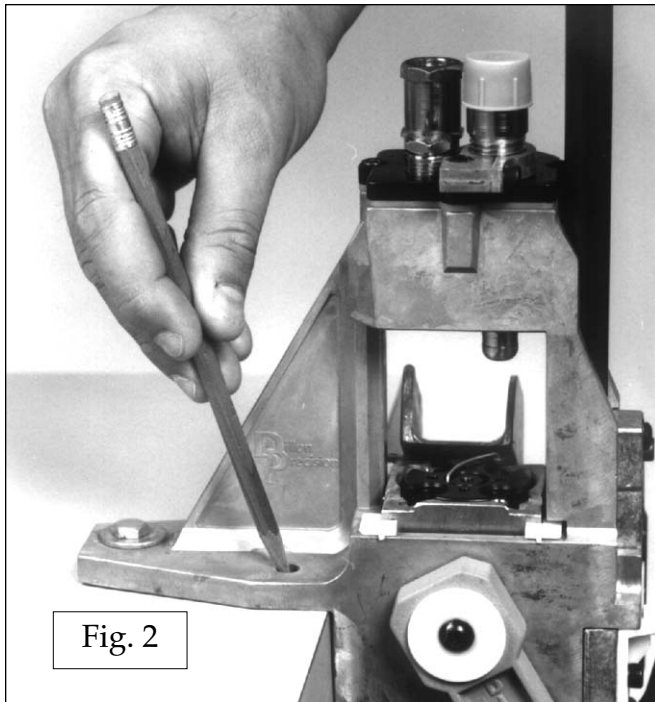

Fig. 2

Fig. 2 – Using the machine itself as a template, mark the three mounting holes. Allow about one foot on both sides of your Square Deal “B” for working room. Make sure your bench is sturdy and does not shake, as this may disturb your powder charge and primer system.

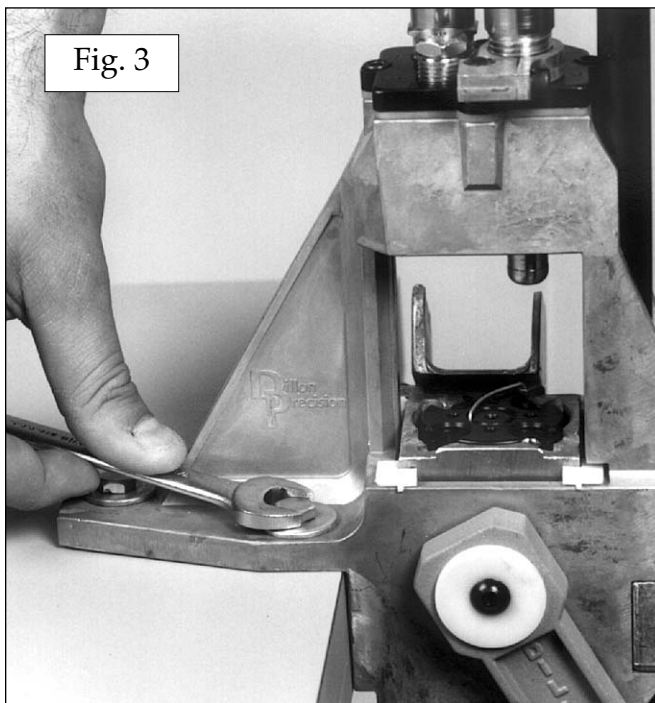

Fig. 3

Fig. 3 – Drill the mounting holes and secure the Square Deal “B” to your bench, using 1/4" bolts (not supplied).

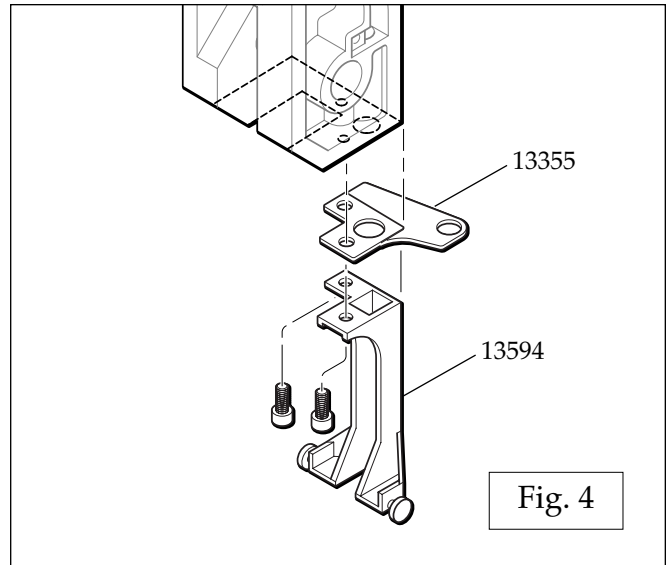

Fig. 4

Fig. 4 – Install the return bracket (#13355) between the bottom of the shaft (#13437) and the spent primer chute (#13594). The spent primer cup (#13651) simply hooks on the bottom of the chute.

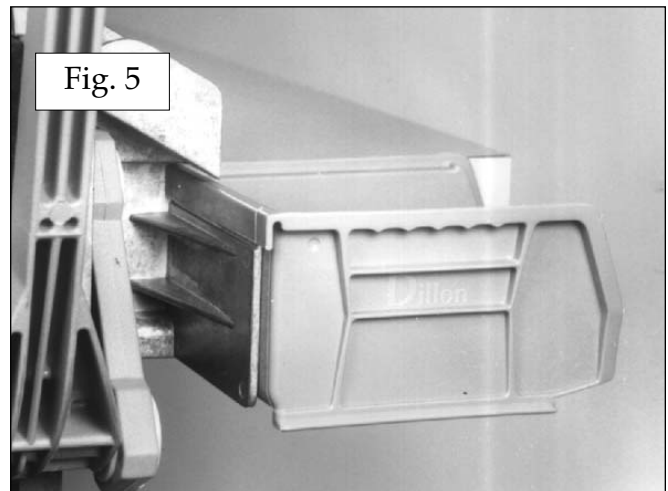

Fig. 5

Fig. 5 – Slide the cartridge collection box (#13756) onto the chute bracket (#13659) as shown.

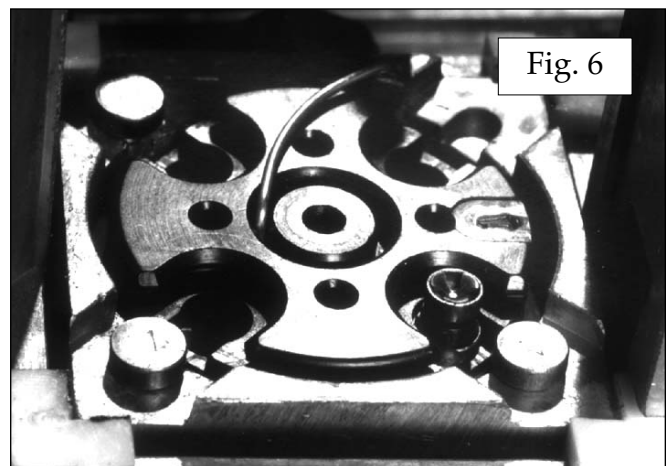

Fig. 6

Fig. 6 – The locator buttons must be placed at Stations 2, 3 and 4 to prevent the cartridge from sliding off of the shellplate. The buttons can be removed to access the case at these stations.

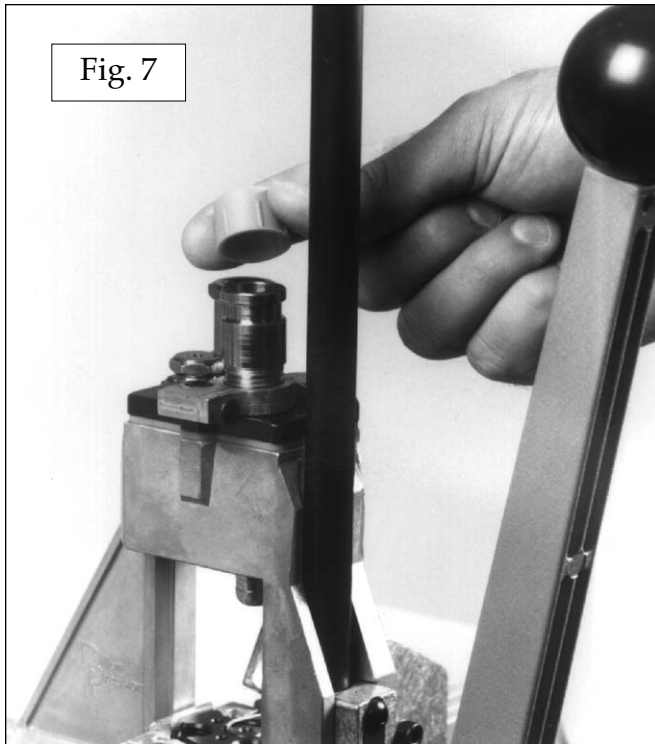

Fig. 7

Fig. 7 – Remove the cap from the top of the powder die (#13865). The cap retains the expander/powder funnel during shipping.

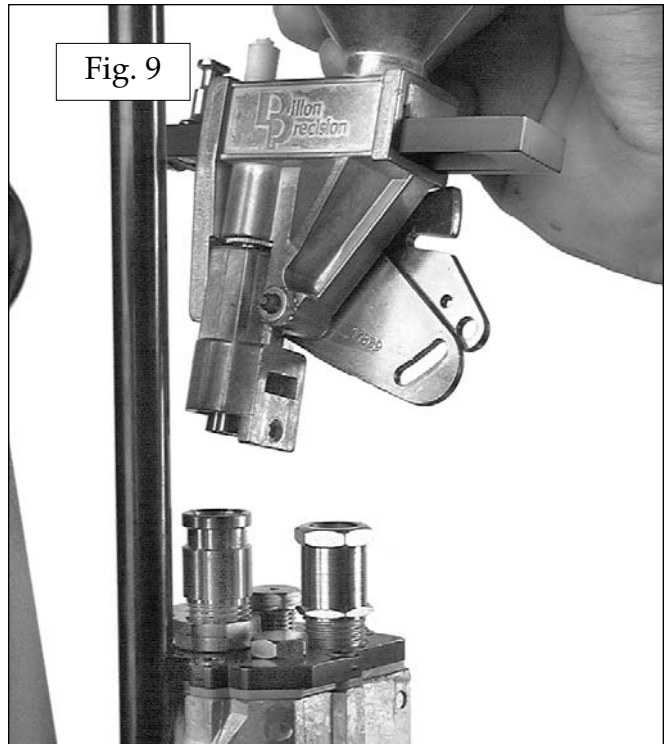

Fig. 9

Fig. 9 – With the cap removed and the expander/powder funnel in position, you are now ready to install the powder measure. Place the powder measure on top of the powder die.

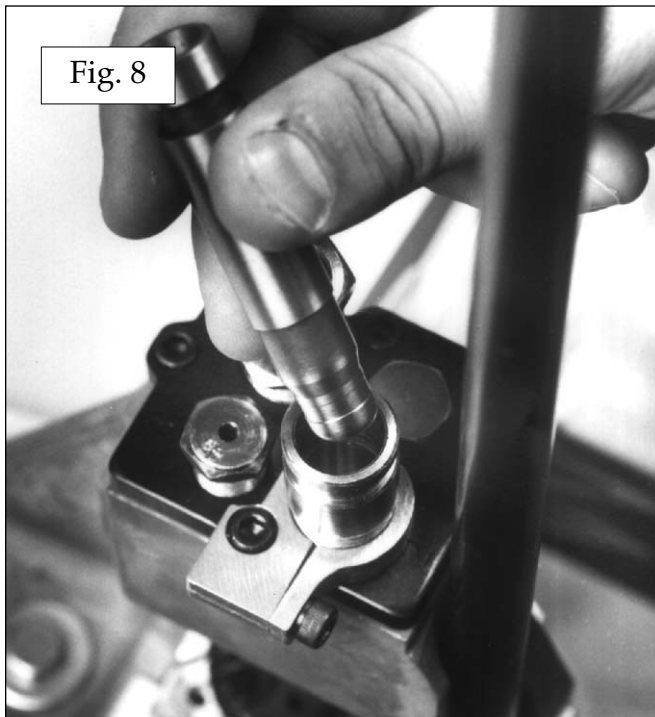

Fig. 8

Fig. 8 – Make sure the expander/powder funnel is free to move in the powder die and reinsert it as shown.

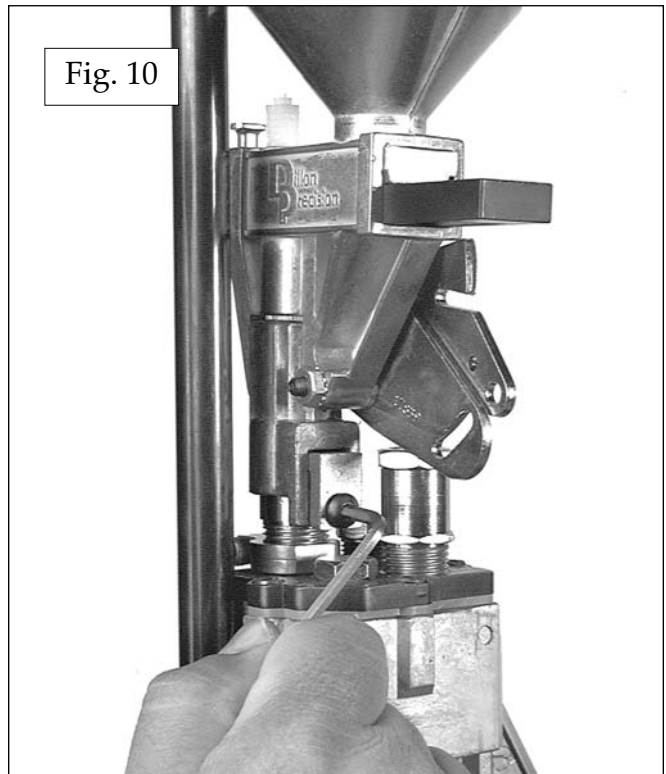
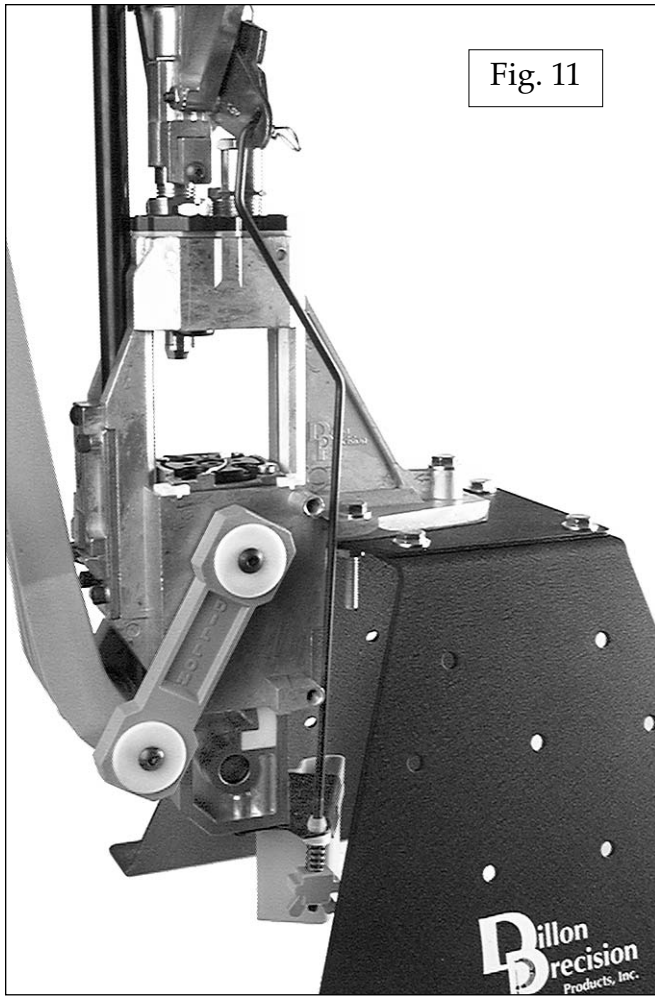

Fig. 10

Fig. 10 – The powder measure is held in place by the powder die clamp (#13986). Tighten in place, but do not over tighten.



To install the failsafe rod (#16814) remove the blue stripper wingnut (#13799), rod spring (#14033) and washer (#18086). (Note the order of parts.) See Fig. 11

Insert the bottom end of the rod between the bench and the Square Deal "B" through the hole in the return bracket (#13355). Then, using your thumb and index finger of your right hand, move the lock-link (#17838) down to align the hole with the slot on the Powder Measure bellcrank (#17839). Next, insert the failsafe rod (#16814) through the two holes and insert the failsafe rod clip (#13840).

Install the washer (#14033) and the wingnut (#13799). With your left hand, move the operating handle (#20114) to the priming position; press the operating handle firmly forward and with your right hand adjust the wingnut until the spring is partially compressed. You are now ready to reload. Refer to the rear view in Fig. 11 to assist in the rod location and proper powder measure positioning.

Check It Out

Your assembly should now be complete, but before you stock it with powder and primers let's run through the operation a few times.

Your Square Deal "B" has been adjusted at the factory in the caliber of your choice and we've enclosed the sample rounds that we used to obtain those adjustments. One cartridge has a bullet seated to illustrate the seating depth and the other round was primed (the primer is inert).

Place the cartridge case without the bullet in Station 1 and pump the operating handle. The primer will be pushed out and dropped into the spent primer cup (#13651). Continue to pump the handle and observe the advancement of the cartridge from station to station until it is ejected into the cartridge collection box. Now take a new primer and drop it (shiny side down) into the primer magazine (#13673). Operate the handle and the primer will appear at Station 2, press forward on the handle, pick up the primer with your fingers and put it back into the primer magazine. The forward pressure on the handle is important as it exerts the pressure necessary to seat the primer in a cartridge.

Reinsert the case in Station 1, drop the primer in the primer magazine and operate the handle. As the case is moved to Station 2 press forward firmly but gently and you will feel the primer being seated. Cycle the machine and eject the primed round.

IMPORTANT: Let's do it again but this time do not put the primer in the magazine. Repeat the sequence using an unprimed case. Notice how the primer punch tends to stick in the cartridge when no primer is present. This is the feeling you get when your Square Deal "B" runs out of primers.

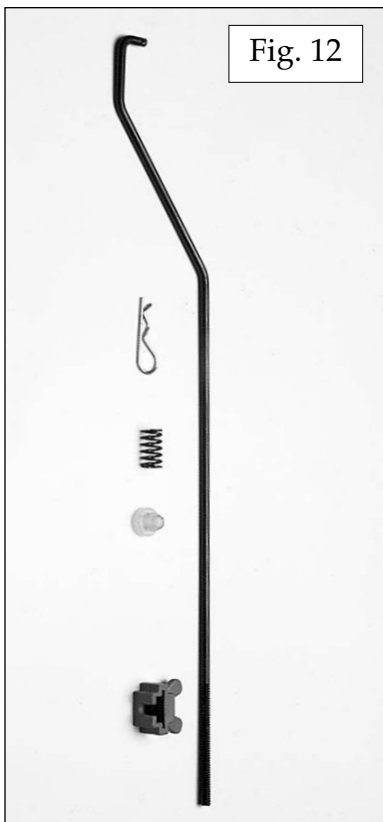

Fig. 11 & 12 – Installation of the Powder Measure Failsafe System.

Now that you've seen the Square Deal "B" function, read the following description of what is happening at each station.

Understanding the Machine

Station 1: When a cartridge is fired, it expands. The carbide resizer returns it to factory dimensions. The primer decap pin knocks out the old primer and deposits it into the spent primer cup.

No adjustments are ever necessary at this station.

Station 2: As you recall, when you press forward on the handle you will seat the primer, but that's not all that's happening here. As the cartridge goes up into the powder measure it encounters a powder funnel that slightly "bells" the mouth of the cartridge – this bell or flare enables you to start your bullet easier at Station 3. As the powder funnel is carried upward by the cartridge it will operate your automatic powder measure and dispense the amount of powder chosen.

Two adjustments are possible here. The amount of bell has been adjusted at the factory; however, you may increase or decrease the amount of bell by simply screwing the powder die into or out of the toolhead. (See Fig. 14.)

The second adjustment is the most important of the entire loading sequence and must be approached with a great deal of caution. You must adjust your powder measure to meter the proper weight of powder in grains for the load you've selected from a powder manufacturer's chart or reloading manual.

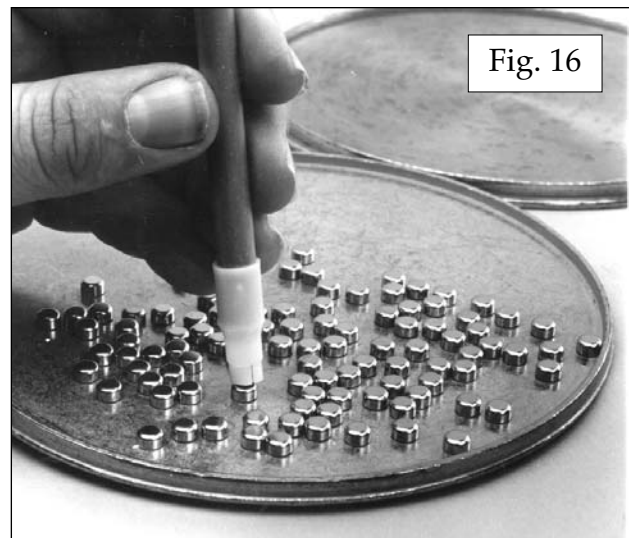
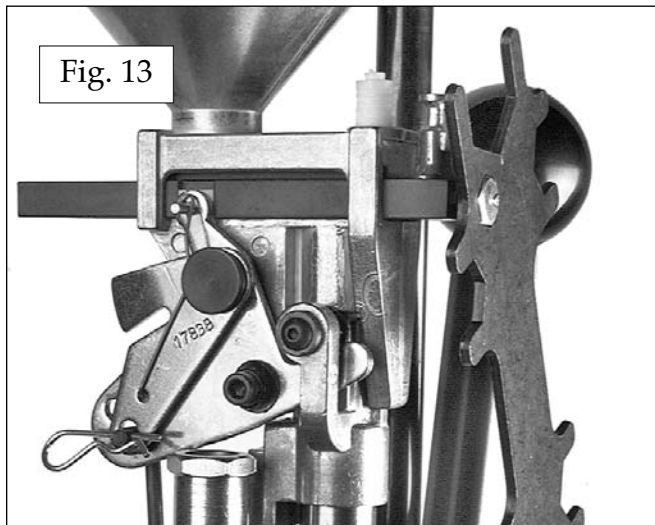
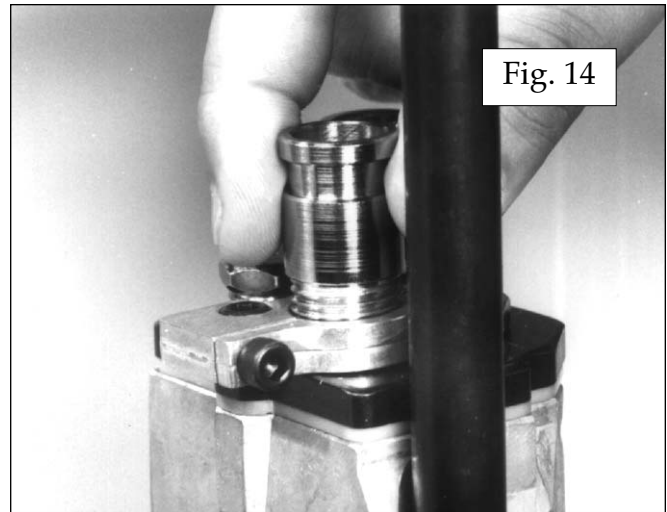

Cycle your empty cartridge into Station 2. Turning the adjusting screw as shown on Fig. 13 will open or close the powder insert. Fill the powder measure with the powder of your choice. Cycle your primed practice round into Station 2 to activate the powder measure. Do this several times and then, using a powder scale, weigh your charge. (See Fig. 15.) Then, by trial and error, continue adjusting until the proper weight of powder is achieved. Run it six more times just to be sure.

With the powder measure up and running let's get some primers.

Fill 'er Up

Using the appropriately sized primer pick up tube, pick up the primers, shiny side up as shown in Fig. 16. This tube will hold approximately 100 primers.

You will notice that the primer magazines and

primer pick-up tubes have different colored tips. They have been color coded to help you identify size more easily.

The color code is as follows:

Blue	Small Primer Magazine Orifice
Red	Large Primer Magazine Orifice
Yellow	Small Primer Pick-up Tube
Green	Large Primer Pick-up Tube

Primers are much easier to pick up if you use a primer flip tray. A quality metal tray is available from Dillon Precision.

Never forget that primers are potentially dangerous. Never hit them or attempt to force them.

Primer Early Warning System Installation

(See page 4 for assistance.) Install the battery and the battery cover (#13857) in the system's main body. Slide the Early Warning System Assembly down over the knurled cap on your primer magazine and lightly tighten the clamp screw.

Pivot the switch lever (#13864) away from the Early Warning System housing to fill the primer magazine with primers.



Invert the primer pick up tube over the knurled cap and pull the primer retaining clip (#14040 – See Fig. 17.) The primers should now fall smoothly into the magazine. Pivot the switch lever back over the Early Warning System housing. Gently slide the follower rod (#13707) down through the switch lever, the knurled cap and into the primer magazine

tube until the follower rod touches the primers.

You are now ready to reload. When you are nearly out of primers (approximately three remaining) the follower rod will activate the buzzer. Never attempt to remove the primer magazine shield, it is there for your protection. Your primer system should now be ready. Let's move on to Station 3.

Station 3: This is an easy one. All we do is seat the bullet to its proper depth in the cartridge case. This depth was adjusted at the factory for the bullet type on the sample cartridge.

We give you a choice of bullet seating stems, use the one closest to the type of bullet you are using.

The depth of bullet seating may be adjusted simply by screwing the seating stem in or out. The adjustment is held in place by a layer of Delrin beneath the toolhead.

Station 4: Another easy one. This station removes the bell and crimps the bullet in place. Once again this adjustment has been performed by Dillon.

More or less crimp can be achieved simply by screwing the crimp adjustment screw (#13908) in or out. Check your reloading manual for crimp dimensions.

Load 'em up

Okay now that you understand the purpose of all of the Square Deal "B" stations, we are ready to reload. Begin as follows:

- 1.) Place a clean, empty case in Station 1 and cycle the handle, don't forget to press forward firmly to seat the primer in Station 2. Work slowly.
- 2.) Place another empty case in Station 1, cycle the handle. Work slowly and carefully, watch the powder bar function and be sure it travels fully to the left each time. If it doesn't, turn the powder die (#13865) 1/8 turn clockwise and try again.
- 3.) Carefully place a bullet on top of the cartridge case at Station 3. Insert a new empty case at Station 1, cycle the handle.

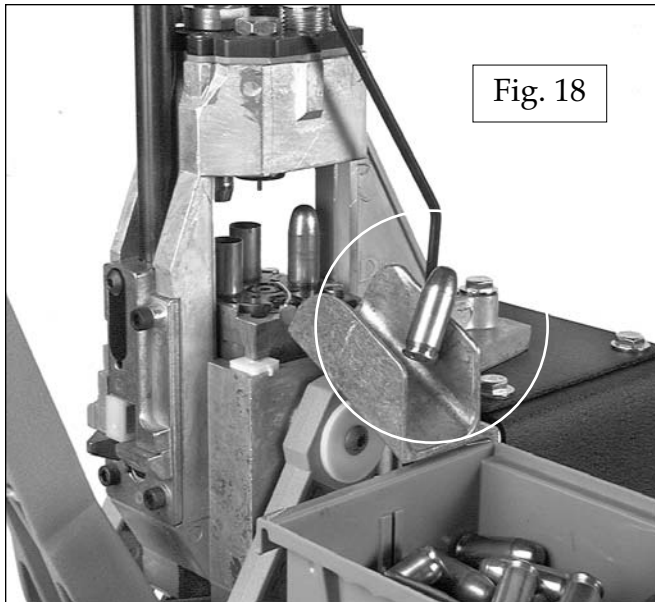

Fig. 18

4.) From this point on, place a bullet on the case at Station 3 with your left hand. Insert a case at Station 1 with your right hand and cycle the handle. Each time you cycle the machine a finished round will be ejected into the cartridge collection bin. (See Fig. 18)

REMEMBER!

Press forward firmly on the handle to seat your primers. Primer jams or misfeeds can be caused by misadjustment of the set screw (#13961) in the primer feed block. The most common case of primer misfeeds or jams is the primer punch not seating fully onto the primer slide. This will cause the primer cup to strike the flexible orifice on the bottom of the primer magazine tube.

Watch the powder bar function, make sure you're getting powder.

Set the bullet straight on the case at Station 3 so that it enters the die correctly.

Watch your supply of powder and primers, you'll be using them faster than you think you are.

Take your time and learn the machine and its function. The Square Deal "B" will deliver hundreds of trouble free rounds in short order, just relax and take your time in the beginning.

Keep it clean – primer residue, spilled powder and just plain dirt can jam your machine. All bearing surfaces are Delrin and require no lubrication.

Clean your powder bar and underneath your shellplate about every 500 rounds. Some powders build up and will eventually stick the powder bar. Paint or lacquer thinner works well to remove any build up.

Friend at the Factory

We started this manual by saying if you have a problem, call us. We mean it. Anyone can make a mistake. There's no such thing as a dumb question. If something is giving you a problem, let us help you!

Technical Support & Order Line

1-800-223-4570 FAX (480) 998-2786

Square Deal "B" Conversion Instructions

Changing calibers on your SDB is a simple procedure.

First, you must decide whether you need to change the priming system that is now set up on your machine. Small calibers use small pistol primers and large calibers use large pistol primers. Skip step one if there are no changes needed.

Step 1: Changing The Priming System

Remove Primer Early Warning System. Remove three screws (#13989 – refer to schematic) to remove the primer system from the front of the machine. Remove the primer slide return spring from pin (#13790) and remove the primer slide assembly from the magazine system. Replace the correct size primer slide in the same manner.

IMPORTANT Make sure the magazine is empty of all primers by inverting the primer assembly.

Remove cap (#13957) and pull out the internal magazine tube (#13673). Take the correct size magazine tube and drop a primer, anvil side up, into the top of the tube to make sure the primer drops freely through the tube and orifice. Insert the magazine tube (#13673) into the magazine shield with the keyed side of the orifice pushed all the way down into the notch or key way in the housing (#20900). Replace the cap (#13957). Do not over tighten!

Now, insert a few primers, anvil side up, into the magazine. Pull the handle, a full stroke, raise the handle and a primer should appear at Station 2. If a primer fails to appear, adjust the primer feed adjustment screw (#13961a), located at the lower tip of the flat spring (#13979) on the front of the housing (#20900) as follows:

If changing from a large primer to a small primer turn the primer feed adjustment screw (#13961a) in 1/8 turn increments clockwise. If changing from small to large, turn in 1/8 turn increments counterclockwise.

Give the handle another full stroke and a primer should appear. If the primer cup is not centered under the shellplate or snaps into place when the handle is raised it may be necessary to adjust the primer slide travel by turning the slide stop adjustment screw (#13961b) in 1/8 turn increments. It is located between the primer slide and the coiled spring (#13798) on the front on the housing. (See pages 3 & 4.)

Step 2: Changing Shellplates

Lift out the ejector wire (#13433) and remove the shellplate bolt (#13328). Carefully remove the shellplate and be aware of a very small index ball (#14019) that sits on a spring. Install the correct shellplate.

The short end of the ejector wire fits behind the shellplate bolt (#13328). Note: The correct positioning of the ejector wire is important or serious damage to the sizing die could result. See Fig. 14.

Step 3: Changing and Adjusting Dies

Use of Dillon's Bench Wrench is suggested when changing or adjusting dies.

Remove screw (#13895) and remove the powder measure. Remove screws (#13815) and (#14037) and remove the toolhead assembly. Lift out the three die inserts (#12864, #11628, #11734) from the frame. Note: The toolhead you just removed is adjusted for those dies. Store these parts for when you set up this caliber again.

Now, take the dies of the caliber that you are converting to and insert them into the frame, corresponding to the position reference number on each die. 1, 3 & 4. If you choose to use the toolhead you removed, be certain that you back out the adjustment bolt (#13908) at Station 4 and remove the seating stem at Station 3.

Reinstall the toolhead with screws (#13815).

Drop the correct powder funnel expander in the die body (#13865) and mount the powder measure just as you removed it. Loosen the clamp screw (#13895).

To achieve proper adjustment of the die it is important to understand that the adjustable powder bar should reach the end of its travel at the same time that the handle reaches the bottom of its stroke against the frame stops.

To achieve this adjustment, the die body (#13865) must be screwed up or down. A sized empty shell case must be placed in the shellplate at Station 2 in order to check this adjustment. No powder should be in the measure during these adjustments.

Beware! If you pull the handle and the powder bar reaches the end of its travel before the handle reaches the bottom of its stroke, STOP! Raise the die (#13865) several turns and try again. Once the adjustment is correct but you want the case mouth flared a little more, just screw die (#13865) down 1/4 turn or less.

The base of the bullet needs only to set within a slightly flared case mouth.

Tighten screws (#14037) and (#13895).

Now, you can adjust the powder measure for the charge your loading data tells you to use. Remember that the powder charge adjustment screw (#13943) turns counterclockwise to decrease the volume of charge and clockwise to increase the charge.

Your conversion kit comes with the seating stems to fit the most popular bullet styles; wadcutters, semi-wadcutters and round nose. Choose one and insert it in Station 3. Simply seat the bullet to a desired depth. Consult your loading data!

Now, index your seated cartridge to Station 4. Lower the handle all the way against the frame stops. Turn the die adjustment bolt (#13908) down until you feel a slight opposition. Raise the handle and turn the adjustment bolt clockwise 1/4 to 1/2 a turn. Insert this cartridge back into the shellplate at Station 4 and give the handle a full stroke. The crimping die is now adjusted and you're ready to start loading.

Reloading Tips:

If you're using new unfired brass remove the sizing die (#12864). Virgin brass usually does not require full length sizing. (Optional)

Always give the handle a FULL STROKE or remove all cases and start over, as operations may be only partially completed.

Use cleaned brass or damage to dies may result. Avoid the use of military brass with crimped primer pockets. Crimps can easily be removed with a Dillon SS-600.

Mount the machine on a sturdy work bench that will not move while loading. Bench movement will impair your ability to prime correctly. Suggestion: Nail or screw your bench directly to your wall.

Keep your machine clean! Read this manual carefully! If you have any questions please call us! We'll help. 1-800-223-4570

NOTICE!

THIS MACHINE IS DESIGNED SPECIFICALLY TO BE A MANUALLY OPERATED HANDLOADING MACHINE. ANY ATTEMPTS TO MECHANIZE THIS PRODUCT WILL VOID ANY AND ALL WARRANTIES OFFERED BY THE COMPANY. WE SPECIFICALLY WARN AGAINST CONVERTING THIS PRODUCT TO AUTOMATED OR MOTORIZED OPERATION.

All Dillon machines are warranted for life from defects in material or workmanship, plus a one year 100% warranty against normal wear. All electrical/electronic components in Dillon equipment are covered by a one year warranty.

Caliber Conversion Chart

Caliber	Shellplate	Locator Button	Powder Funnel
.45 ACP	#1	#1	E
.38 / .357	#2	#2	D
.380 Auto	#3	#3	F
.44 Mag. / Spcl.	#4	#4	G
9mm / .38 Super	#5	#3	F
.41 Mag.	#6	#1	H
.45 LC	#C	#4	E
10mm	#W	#2	W

On the cover...

The Square Deal B is pictured with optional accessories:

SDB Strong Mount #22223

Low Powder Sensor #16306

Other accessories available for the Square Deal B include:

Bullet Tray #22214

Machine Cover #13795

Maintenance Kit & Spare Parts Kit #97015

The **Blue Press**, Dillon's monthly catalog, has a complete listing of accessories available for all machines.

Dillon Precision Products, Inc.

8009 E. Dillon's Way
Scottsdale, AZ 85260

(480) 948-8009

FAX (480) 998-2786

www.dillonprecision.com

e-mail: dillon@dillonprecision.com

Technical Support & Customer Service

(800) 223-4570

