



# SPRING SUMMER 2012

Prices are in effect from March 1<sup>st</sup> to August 31<sup>st</sup> 2012



**Excalibur**  
BY GENERAL INTERNATIONAL  
Aluminum T-fence with 50" rails

50-275RLK M1  
**\$1,999.99**  
reg. \$2,635.00

10" 3 HP cabinet saw (left tilt)  
Powerful 3 HP motor with multi-groove V-belt.

Combination riving style splitter and see-through blade guard with anti-kickback pawls, and a second European style riving knife also included. Large precision ground 44" x 27" cast-iron table with two extension wings. Magnetic safety switch with large stop button.

**Included** Includes 36" extension table (#50-106) and adjustable steel support legs (#50-115).



12" x 17" variable speed "Maxi-Lathe VS+"



25-200 M1  
**\$799.99**  
reg. \$1,116.00

5 pc hi-speed steel wood turning mini-chisel set (Item #25-250)

**Free\***

A \$126.00 value  
\*With the purchase of 25-200 M1 only.



**Pivoting head**

Digital spindle speed display. Quick lock control levers easily position 10" tool rest. Maximum distance of 17 5/16" between centers. 3 variable speed ranges: 300 to 900, 600 to 1800 & 1200 to 3600 RPM. 3/4 HP motor.

32" bed extension for 25-200 M1 only (Item #25-205)



**\$199.99**  
reg. \$260.00

10" jointer with helical cutter head



**Included**



80-250XHC M1  
**\$3,799.99**  
reg. \$5,650.00

Large surface, precision ground cast-iron tables with built-in rabbeting ledge. Two way tilting fence with positive stops at 45° and 90°. 5500 rpm cutter head speed. 3 HP motor.



99-500  
**\$8.99**  
reg. \$9.95

25' (7.5 M) Measuring tape

75-500 M1  
**\$919.99**  
reg. \$1,270.00

22" drill press 3/4" chuck with key, laser line marker & see-through chuck guard included.

Cast-iron pulleys reduce vibration. Large front mounted paddle style stop switch with lock-out safety feature to prevent unwanted or unintentional start-up. Industrial 1 HP motor.

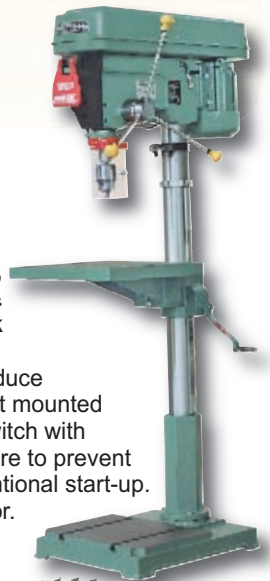

Distributed by:

**FREE\***

\*Receive a 40 tooth 10" carbide blade free with the purchase of any 10" table saw listed in this flyer.

A \$59.99 value

# TABLE SAWS

350R-T50-M2M / 650R-T50-M2M  
350R-ST52-M2M / 650R-ST52-M2M

**\$2,999.99**

reg. \$4,100.00 (T50) / \$4,145.00 (ST52)

350R-T50

GENERAL "T" FENCE SYSTEM  
Made in Canada



Quick release combination riving style splitter and blade guard with anti-kickback pawls.

European style riving knife.

Made in  
**CANADA**

10" 2 HP cabinet saw  
left tilt



Quick release combination riving style splitter and blade guard with anti-kickback pawls and a second European style riving knife also included. Large 44" x 27" cast-iron table with two extension wings. Cast-iron cabinet mounted trunnions. Equipped with a sturdy, easy adjust, T-fence rip fence system. Dual voltage motor pre-wired for 230 V operation.

50-200R M1

**\$1,199.99**

reg. \$1,650.00

10" 3 HP deluxe cabinet saw  
(350R right tilt / 650R left tilt)

Magnetic 2-step safety switch with a lock-out key to prevent unwanted or unintentional start-up is equipped with an extra-large easy access stop panel. "T" fence system with 50" rails (F42T50) or sliding fence system (SLT35T52). 36" extension table with adjustable steel support legs. Arbor mounted on heavy-duty, permanently lubricated, sealed bearings. 3 HP motor.

10" contractor saw  
left tilt



**Excalibur**  
BY GENERAL INTERNATIONAL  
Aluminum T-fence

Combination riving style splitter and see through blade guard with anti-kickback pawls, and a second European style riving knife also included. Heavy-duty, precision cast-iron ribbed table, with miter gauge T-slots, & stamped steel extension wings. Deluxe, quick adjusting miter gauge. Sturdy fixed leg steel stand. 2 HP motor.

50-09RC M1

**\$999.99**

reg. \$1,250.00

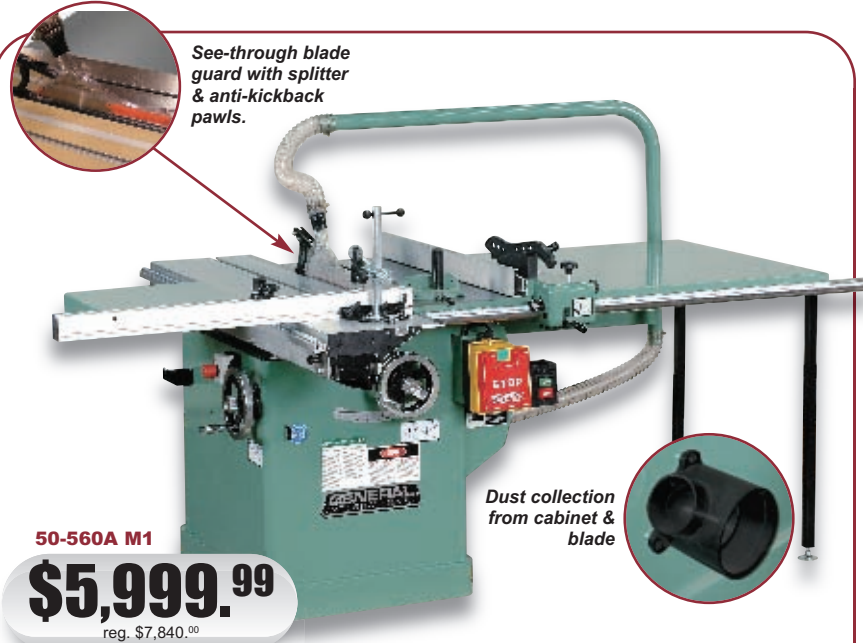

See-through blade guard with splitter & anti-kickback pawls.

Dust collection from cabinet & blade

50-560A M1

**\$5,999.99**

reg. \$7,840.00

10" job site saw  
left tilt



**Excalibur**  
BY GENERAL INTERNATIONAL  
Aluminum T-fence

Combination riving style splitter and see through blade guard with anti-kickback pawls, and a second European style riving knife also included. Heavy-duty, precision cast-iron ribbed table, with miter gauge T-slots, & stamped steel extension wings. Deluxe, quick adjusting miter gauge. Folding stand with wheels. 2 HP motor.

50-090RK M1

**\$1,119.99**

reg. \$1,385.00

10" scoring saw with built-in sliding table  
(left tilt)

Can be used as a regular saw, but includes a built-in sliding table for stable effortless crosscuts & a separate scoring blade for chip-free cuts in melamine & laminates.

Anodized European style sliding table. Separate safety lock out switch for main motor & scoring motor. Solid cast-iron table with anodized aluminum coating. Heavy-duty cabinet mounted cast-iron trunnions. Precision-built rip fence system with 50" guide rails. 3 HP motor.

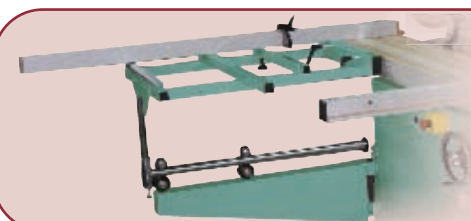

**Free\***

Outrigger slider support  
(Item #50-565A)

An \$890.00 value

\*With the purchase of 50-560A M1 only.

**50-030**  
**\$189.99**  
 reg. \$240.00

**Heavy-duty mobile base for table saws with extension table and legs**  
 900 lbs capacity. 2 heavy-duty 4" wheels. 2 heavy-duty 3" swivel caster with locking levers. 2 swivel casters.

**55-040**  
**\$59.99**

**40 tooth - 10" carbide blade**

**Excalibur**  
 BY GENERAL INTERNATIONAL

**50-EB3**  
**\$124.99**  
 reg. \$210.00

**"Osborne" miter gauge**  
 Solid triangular design for tight miter joints. Sliding flip-up stop. Easy to read index graduations. Patented extension arm assembly makes it quick & easy to find any angle and lock it securely in place.

**50-050**  
**\$134.99**  
 reg. \$196.00

**Tenoning jig for table saws**  
 Fits on right or left tilt table saws. Heavy-duty cast-iron construction. Large handles for better operator control.

**Excalibur**  
 BY GENERAL INTERNATIONAL

**SLF35T52**  
**\$499.99**  
 reg. \$650.00

**New!**

**Sliding rip fence (52" right 16" left)**  
 Heavy duty rip fence with a 3" x 37 1/2" sliding and reversible steel fence face. Magnetic quick engage / disengage flip up fence with micro-adjustment attachment included. Fully adjustable design. Full 50" right rip capacity.

The new Excalibur SLF35T52 Sliding Rip Fence fits on the following General and General International Table Saws: 350, 350R, 650, 650R, 50-250, 50-260, 50-270, 50-275, 50-300, 50-300CE, 50-305, 50-305CE.

# SCROLL SAWS



Head tilts 45° left and right, tilting the blade not the table, keeping the workpiece level. 2" cutting thickness capacity. Variable speed of 400 to 1400 strokes/minute (EX-16) and 400 to 1550 strokes/minute (EX-21 & EX-30).



Tilting head

**EX-21K\***  
**\$819.99**  
 reg. \$1,104.45

**EX-16**  
**\$574.99**  
 reg. \$749.00

**EX-30K\***  
**\$1,029.99**  
 reg. \$1,464.45

**Free**  
 With EX-21K & EX-30K

**#EX-21K\* & #EX-30K\***  
 \*Special edition "K" version with foot switch (item #EX-01) & stand (item #EX-21BS for EX-21 / #EX-30BS for EX-30) included.

**Excalibur**  
 BY GENERAL INTERNATIONAL

**Miter angle adjustment rail with positive stop pin.**

**Onboard storage mounts for cross cut fence.**

**Sliding tables**  
 #50-SLT40P (shown)  
**\$1,249.99**  
 reg. \$1,500.00  
**Fits on most 10" to 14" table saws.**  
 Easy to adjust, extruded aluminum miter fence for accurate miters from 0° to 50°. Cut up to 49"\* with the crosscut fence positioned at the rear of the table. Crosscut and miter up to 28"\* with the fence at the front of table.

#50-SLT60P (not shown)  
**\$1,459.99**  
 reg. \$1,790.00  
**Fits on most 10" to 14" table saws.**  
 Easy to adjust, extruded aluminum miter fence for accurate miters from 0° to 45°. Cut up to 72"\* with the crosscut fence positioned at the rear of the table. Crosscut or miter up to 49"\* with the fence at the front of the table.

\* Depending on the positioning of the main mounting bracket on your saw.

**Free\***

**Hold-down clamp**  
 (Item #50-EXHDC)  
 A \$127.25 value

\*With the purchase of 50-SLT40P or 50-SLT60P only.

# JOINTERS

## 8" parallelogram jointer

### Large surface 82 7/8" cast-iron tables

Heavy-duty center-mounted cast-iron fence with 45°, 90° and 135° positive stops. Precision four point parallelogram table adjustment system. Magnetic safety switch mounted above the in-feed table for quick, easy access. 5000 rpm cutter head speed. 3 HP motor.

### Included

With 80-225HC M1



**Magnum helical cutter head**

(4 rows, total: 22 inserts)



80-225HC M1

**\$3,539.99**

reg. \$4,200.00

## 6" jointer



80-075L M1

**\$729.99**

reg. \$890.00

### 55 1/4" long tables

Large surface, ground cast-iron tables. Heavy-duty, three-knife cutter head. Jackscrew system for quick, easy knife adjustment. Independent in-feed and out-feed table adjustment handwheels. 5000 rpm cutter head speed. 1 HP motor.

80-100L M1

**\$894.99**

reg. \$1,100.00

## 6" closed base jointer

### 55 1/4" long tables

Large surface, ground cast-iron tables. Cast-iron fence with 90° & 45° positive stops. Independent in-feed and out-feed table adjustment handwheels. 5000 rpm cutter head speed. 1 HP motor.



80-100LHC M1

**\$1,379.99**

reg. \$1,800.00

## 6" closed base jointer with Magnum helical head

Same features as model 80-100L M1 + Magnum helical head.

### Included

With 80-100LHC M1



**Magnum helical cutter head (item #100H)**  
(4 rows, total: 16 inserts)

## 6" deluxe jointer, 66 1/4" tables



80-125L M1

**\$1,249.99**

reg. \$1,825.00

### 66 1/4" extra long tables

Large surface, ground cast-iron tables. Large, heavy-duty, center-mounted cast-iron fence with 90° and 45° positive stops. Independent in-feed & out-feed adjustment handwheels. 5000 rpm cutter head speed. 1 HP motor.

80-200L M1

**\$1,973.99**

reg. \$2,400.00

## 8" jointer

### 74 7/8" extra long tables

Large surface, ground cast-iron tables. Independent in-feed & out-feed table adjustment handwheels. Magnetic switch for added safety. 5500 rpm cutter head speed. 2 HP motor.



80-200LHC M1

**\$2,598.99**

reg. \$3,250.00

## 8" jointer with Byrd style helical head

Same features as model 80-200L M1 + Byrd style helical head.

### Included

With 80-200LHC M1



**Byrd style helical cutter head (item #200H)**  
(4 rows, total: 36 inserts)

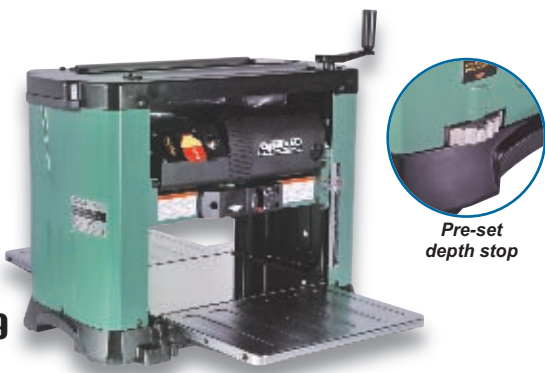

Pre-set depth stop

**30-005HC M1**  
**\$689<sup>99</sup>**  
 reg. \$849.<sup>00</sup>

13" planer with helical head  
 Helical cutter head with 26 reversible two-sided high speed steel inserts.  
 Built-in inset lifting handles. Large depth of cut adjustment handle – one full rotation equals 1/16". 2 HP motor.

**30-120 M1**

**\$1,999.<sup>99</sup>**  
 reg. \$2,650.<sup>00</sup>

7" molder  
 Magnetic 2-step safety switch to prevent unwanted or unintentional start-up is equipped with an extra-large and a lock-out key. Cast-iron table and head. Precision machined heavy-duty cast-iron dovetailed column. Independent, variable speed feed motor provides added control. 7000 rpm cutter head speed. 2 HP motor.



Elliptical jig included

# PLANERS

**30-115 M1**

**\$1,819.<sup>99</sup>**  
 reg. \$2,200.<sup>00</sup>

15" single surface planer  
 2 feed speeds - 16 & 20 fpm.  
 Magnetic safety switch.  
 Heavy-duty cast-iron frame reduces vibration. Built-in mobile base.  
 3 HP motor.



**Included**  
 With 30-115HC M1



Magnum helical cutter head (item #125H)  
 (4 rows, total: 42 inserts)

**30-115HC M1**

**\$2,599.<sup>99</sup>**  
 reg. \$3,450.<sup>00</sup>

15" single surface planer with **Magnum** helical head  
 Same features as model 30-115 M1 + Magnum helical head.

**30-300 M1**

**\$3,319.<sup>99</sup>**  
 reg. \$4,290.<sup>00</sup>

20" single surface planer  
 2 feed speeds - 16 & 20 fpm.  
 Magnetic safety switch.  
 Built-in mobile base with one-step lock-pedal.  
 5 HP motor.



Mobile base

**30-300HC M1**

**\$4,439.<sup>99</sup>**  
 reg. \$6,300.<sup>00</sup>

20" single surface planer with **Magnum** helical head  
 Same features as model 30-300 M1 + Magnum helical head.

**Included**  
 With 30-300HC M1



Magnum helical cutter head (item #30300H)  
 (4 rows, total: 58 inserts)

**30-125CE M1**

**\$2,114.<sup>99</sup>**  
 reg. \$2,760.<sup>00</sup>

15" single surface planer  
 2 feed speeds - 16 & 20 fpm.  
 Magnetic safety switch.  
 Triple V-belt drive for greater power.  
 Built-in mobile base. 3 HP motor mounted in cabinet for protection from dust.



**Included**  
 With 30-125HC M1



Magnum helical cutter head (item #125H)  
 (4 rows, total: 42 inserts)

**30-125HC M1**

**\$3,049.<sup>99</sup>**  
 reg. \$4,275.<sup>00</sup>

15" single surface planer with **Magnum** helical head  
 Same features as model 30-125CE M1 + Magnum helical head.

**30-360 M1, M2, M3**

**\$4,999.<sup>99</sup>**  
 reg. \$6,225.<sup>00</sup>

20" single surface planer  
 2 feed speeds - 22 & 28 fpm.  
 Magnetic safety switch. Built-in table rollers reduce friction. Positive gear design for quick and accurate table adjustments.  
 7 1/2 HP motor.



**30-360HC M1, M2, M3**

**\$6,299.<sup>99</sup>**  
 reg. \$8,700.<sup>00</sup>

20" single surface planer with **Magnum** helical head  
 Same features as model 30-360 M1, M2, M3 + Magnum helical head.

**Included**  
 With 30-360HC



Magnum helical cutter head (item #360H)  
 (4 rows, total: 58 inserts)

# SANDERS

## 13" horizontal single drum sander



15-155 M1

**\$1,329.99**

reg. \$1,600.00

### Heavy-duty open steel stand.

Heavy-duty open steel stand. Independent switches with removable safety key for both conveyor motor and main motor. 6 to 20 fpm variable feeding speed (conveyor belt). 1 1/2 HP motor.

## Oscillating spindle sander



Tilting table

15-220 M1

**\$464.99**

reg. \$585.00

### Bench top model Precision ground cast-iron tilting table.

29 oscillations per minute. 1720 rpm spindle speed. 5 interchangeable spindles including 1/4", 1/2", 5/8", 1 1/2" & 2". 1/2 HP motor.

## Oscillating spindle sander



Tilting table

15-020 M1

**\$1,374.99**

reg. \$1,789.00

### Floor model Heavy-duty oil bath gearbox.

75 oscillations per minute. 1725 rpm spindle speed. 10 interchangeable spindles from 1/4" to 4" including 1/4", 3/8", 1/2", 5/8", 3/4", 1", 1 1/2", 2", 3" & 4". 1 HP motor.

15-005 M1

**\$959.99**

reg. \$1,259.00

## 6" x 89" edge belt sander

Sanding belt operates at any angle from horizontal to vertical.

Graphite covered steel platen for reduced friction and extended belt life. 1 1/2 HP motor.

15-005S M1

**\$1,059.99**

reg. \$1,319.00

## 6" x 89" oscillating edge belt sander

Same features as model 15-005 M1 + oscillating feature.



15-005 M1 shown

15-010 M1

**\$1,899.99**

reg. \$2,375.00

## 6" x 108" vertical edge belt sander

Tables can be adjusted up or down for full belt use.

Graphite backing reduces belt friction for longer belt life. Dynamically balanced 7" rubber drive roller and crowned 3" idler roller to ensure solid belt tracking. 2 HP motor.

15-010S M1

**\$2,199.99**

reg. \$2,650.00

## 6" x 108" oscillating vertical edge belt sander

Same features as model 15-010 M1 + oscillating feature.



15-010S M1 shown

15-275 M1

**\$5,999.99**

reg. \$7,200.00

## 37" horizontal double drum sander

- 7 1/2 HP

Heavy cast-iron table with four solid jackscrews with chain drive to keep the table level at all times.

Two (2) magnetic safety switches - one for main motor and one for conveyor motor. Rear drum adjustment lever with convenient reference scale, no tools or gauge blocks required. 3.7 to 14.2 fpm variable feeding speed (conveyor belt). 7 1/2 HP motor.



# GRINDERS

#15-710

Optional heavy-duty 34" stand for 6", 8" and 10" bench grinders

Heavy-duty cast-iron table & base, tubular steel column with water tray included.



**\$109.99**  
reg. \$135.00

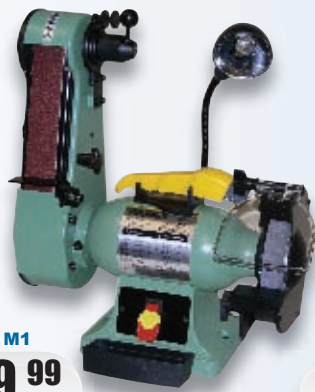

15-232 M1  
**\$199.99**  
reg. \$245.00

**Belt sander / grinder**  
3450 RPM grinding speed.  
4900 fpm belt speed. 1/2 HP motor.



15-625 M1  
**\$109.99**  
reg. \$140.00

**6" low speed bench grinder**  
Double sealed ball-bearing construction.  
Adjustable aluminum tool rests. Low  
1725 rpm. 1/2 HP motor.



15-825 M1  
**\$184.99**  
reg. \$215.00

**8" low speed bench grinder**  
Double sealed ball-bearing construction.  
Adjustable cast tool rests. Low 1725 rpm.  
1/2 HP motor.

#15-035 M1 (shown)

**\$1,199.99**  
reg. \$1,550.00

**6" x 48" belt & 12" disc sander**  
Two large surface, cast-iron, tilting  
tables for unlimited sanding operations.  
Sanding belt operates at any angle from  
horizontal to vertical with positive stops at  
90° and 45°. 2250 FPM belt speed. 1750  
rpm disc speed. Heavy-duty model (365 lb).  
1 1/2 HP, 110/220 V motor.



Safety switch with key  
(15-035DC M1 only)



#15-035DC (not shown)

**\$1,299.99**  
reg. \$1,700.00

**6" x 48" belt & 12" disc sander**  
with built-in dust collector  
Same features as model 15-035 M1.



**Included**  
With 15-035DC M1

15-030 M1

**\$2,399.99**  
reg. \$2,950.00

**15" open type wide belt sander**

Conveyor motor equipped with  
independent safety switch with  
removable key. Magnetic safety  
switch on main motor. Side and  
rear extension tables for easier  
stock handling. 3 to 20 fpm variable  
feeding speed (conveyor belt).  
3 HP motor.



New and improved  
oscillation system

15-250 M1

**\$2,299.99**  
reg. \$2,900.00

**24" horizontal double  
drum sander - 3 HP**  
Two 5" diameter aluminum  
drums.  
High quality conveyor belt for long  
service life. Magnetic safety switch.  
3 to 20 fpm variable feeding speed  
(conveyor belt). 3 HP motor.



Two 5" diameter  
aluminum drums

15-245 M1

**\$4,599.99**  
reg. \$5,700.00

**25" horizontal double  
drum sander - 5 HP**  
Steel frame and heavy-duty base for  
greater stability. Includes dual access  
doors.  
Two (2) magnetic safety switches for main  
motor and conveyor motor. Amp meter for  
motor load indicator. 3.7 to 14.2 fpm variable  
feeding speed (conveyor belt). 5 HP motor.



Rear drum  
adjustment lever

# BANDSAWS

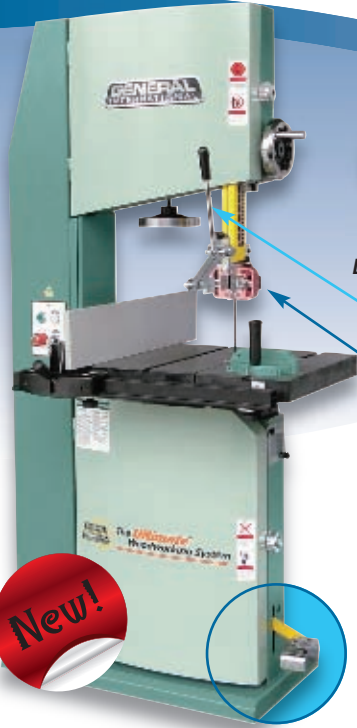

**90-290 M1**  
**\$3,089.99**  
 reg. \$3,600.00

**Excalibur**  
 Deluxe rip fence system included  
 Safety feed device



Upper and lower dual bakelite block and 5 bearing, deluxe blade guide system, with 10 points of contact

**Deluxe 18" heavy-duty wood cutting bandsaw**  
 Laser line marker & 3/4" blade included. Heavy-duty one piece frame. **Safety foot brake simultaneously stops blade and motor.** 2 cutting speeds: 2820 & 3936 fpm. 3 HP motor.

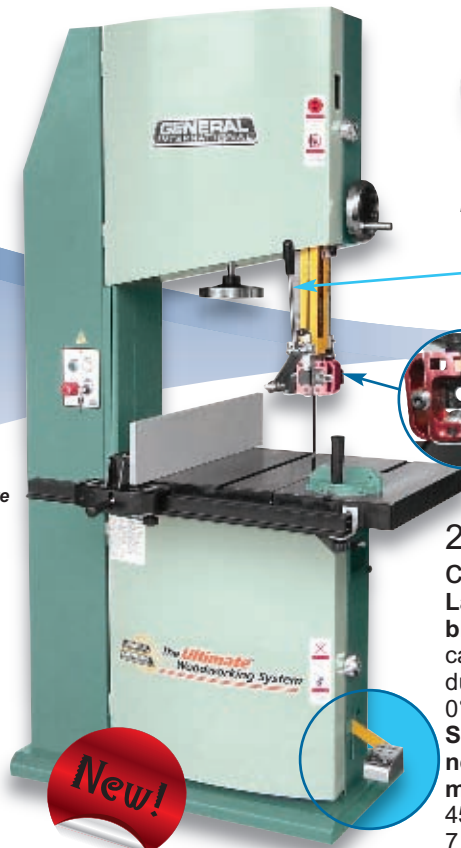

**90-380 M1, M2, M3**  
**\$3,999.99**  
 reg. \$4,650.00

**Excalibur**  
 Deluxe rip fence system included

Safety feed device



Upper and lower dual bakelite block and 7 bearing, deluxe blade guide system, with 10 points of contact

**22" heavy-duty wood cutting bandsaw**  
 Laser line marker & 3/4" blade included. Solid ribbed cast-iron table with heavy-duty one-piece trunnion and 0° to 45° right tilting action. **Safety foot brake simultaneously stops blade and motor.** Cutting speed: 4590 fpm. 5 HP (M1) & 7 1/2 HP motor (M2 & M3).



## 14" wood cutting bandsaw

**90-140 M1**  
**\$679.99**  
 reg. \$775.00

3/8" blade included  
 Cast-iron frame & precision-balanced aluminum wheels with replaceable rubber tires. Rip fence & miter gauge included. 2 blade speeds: 1800 & 3000 fpm. Blower device. 1 HP motor.

Optional riser attachment for 90-140 M1 (Item #90-130A)

**\$87.99**  
 reg. \$140.00



Quick release blade tension

**Excalibur**  
 Deluxe rip fence system included

**90-240 M1**  
**\$1,899.99**  
 reg. \$2,400.00

**17" wood cutting bandsaw**  
 Laser line marker & 1/2" blade included.  
 Solid, high quality, precision-machined, ribbed cast-iron table. 2 blade speeds: 1560 & 3190 fpm. Wide blade selection (1/8" to 1"). 2 HP motor.



**Excalibur**  
 Deluxe rip fence system included

**90-170B M1**  
**\$1,594.99**  
 reg. \$1,950.00

**Deluxe 14" wood cutting bandsaw**  
 Large 12" resaw capacity. 3/4" blade included.  
 One-piece molded frame. Dynamically balanced heavy cast-iron wheels. 2 blade speeds: 2300 & 3250 fpm. Safety foot brake stops blade & motor. 1 1/2 HP motor.



## 14" wood cutting bandsaw

**90-125 M1**  
**\$949.99**  
 reg. \$1,200.00

3/8" blade included  
 Cast-iron frame and precision-balanced aluminum wheels. Safety lock-out switch with removable key. 2 blade speeds: 1630 & 2730 fpm. 1 HP motor.

Optional riser attachment for 90-125 M1 (Item #90-130)

**\$87.99**  
 reg. \$140.00



**Excalibur**  
 Deluxe rip fence system included



**Excalibur**  
 BY GENERAL INTERNATIONAL

**Universal bandsaw rip fence system**  
 21" fence & 29" (front rail) & 25 3/4" (rear rail). Fits on General International models: 90-100, 90-125, 90-140, 90-170.



**90-075A**  
**\$149.99**  
 reg. \$165.00



# WOOD LATHES



14" tool rest and a 6" face plate included



Movable emergency switch can be placed to suit the operator

**New!**  
Cast-iron stand

25-650 ABC M1

**\$2,249.99**  
reg. \$2,990.00

## 16" x 42" wood turning lathe Electronic variable speed

Specifically designed and built for professionals who want superior performance. Headstock swivels 360° with positive stops at 0°, 45°, 90°, 135°, 180° & 270° and quick-lock for out-board turning. Electronic inverter for variable speed adjustment between 45-3750 rpm. Digital spindle speed (rpm) readout. Quiet, highly efficient, low power consumption 2 HP motor.

25-010 M1

**\$229.99**  
reg. \$329.00

**Included**

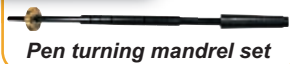

Pen turning mandrel set



**New!**

## Pen turning mini-lathe

Designed and built specifically for turning pens and other smaller hobby type projects. Quick lock control levers easily position tool rest. Extruded aluminum frame, head and tailstock. Maximum distance of 12" between centers. 3 speeds: 1350, 2250 & 3500 rpm. Quiet, smooth running 1/8 HP motor.

## 14" x 17" variable speed "Maxi-Lathe VF"



"Maxi-Lathe" duplicator (Item #25-024)

A \$349.00 value

\*With the purchase of 25-114QC M1 only.

25-114QC M1

**\$799.99**  
reg. \$1,129.00

Forward / reverse spindle rotation.

Digital spindle speed display. Maximum of 17" between centers. 3 variable speed ranges; 250-800, 550-1700 & 1200-3600 rpm. Heavy-duty 1" diameter tool rest post. 3/4 HP motor.

**Free\***



23" bed extension for 25-114QC only (Item #25-116)



**\$199.99**  
reg. \$260.00



25-036

**\$419.99**  
reg. \$570.00

## 36" wood lathe duplicator

Fits most 12" - 22" floor model lathes with cast bedways. Extruded aluminum base and carriage. Smooth handwheel controlled rack & pinion system. High speed steel cutter. (Wood lathe not included)



25-195N

**\$179.99**  
reg. \$249.00

25-196

**\$109.99**  
reg. \$140.00

## Steel support stand for Maxi-Lathe (#95-195N) & bed extensions (#95-196)

Fits General International Models: 25-100, 25-114, 25-114QC & 25-200.

## Pen turning starter

Includes 1 pen turning hardware kit for each of the following pen styles:



Example of a completed Executive pen

Slimline pen (Item #25005-BC211)



Vertex pen (Item #25005-BP702)



Funline pen (Item #25005-BC214)



Polaris pen (Item #25005-BP831)



Executive pen (Item #25005-BP418)



5 wooden pen blanks

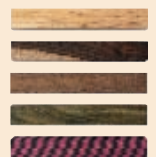

## Bonus

1 wine stopper hardware kit (Item #25005-S991)



\* Images shown for reference only. (Fully assembled pen and wine stopper are not included.)

25-005

**\$49.99**  
reg. \$79.00

# DRILL PRESSES



70-905  
**\$144.99**  
 reg. \$219.00

### Mortising attachment kit

Convert almost any drill press into a mortiser in minutes!  
 CONTENTS: Mounting hardware. Cast-iron chisel holder. Guide fence with workpiece hold down. 4 of the most commonly used mortising chisel and bit sets with 5/8" bit shank x 1/4", 1/16", 3/8" & 1/2". Includes 52, 55, 58, 60, 65 and 66 mm adapter bushings.



70-300  
**\$14.99**  
 reg. \$25.40

**Laser pointer for drill press**  
 Can be installed on most drill presses.



70-120  
**\$69.99**  
 reg. \$101.95

**Self-centering pen drilling vise**

### 17" extended stroke drill press

6" stroke



75-260 M1  
**\$749.99**  
 reg. \$975.00

3/4" chuck with key. Laser line marker & see-through chuck guard included. Extra long quill stroke drills deeper than most drill presses. Large front mounted paddle style stop switch with lock-out safety feature to prevent unwanted or unintentional start-up. 12 spindle speeds: 255 to 2750 rpm. 1 HP motor.

### Radial arm drill press

Line interrupter switch



75-550 M1  
**\$629.99**  
 reg. \$770.00

5/8" chuck with key & see-through chuck guard included. 3 1/8" Spindle travel. 9 spindle speeds: 295 to 3580 rpm. Table swivel 360°. Forced opening switch need a re-start in case of power failure. Table extension provides additional support. 1/2 HP motor.

Line interrupter switch



75-150 M1  
**\$379.99**  
 reg. \$470.00

### 17" drill press

Line interrupter switch



75-200RC M1  
**\$549.99**  
 reg. \$730.00

5/8" chuck with key, laser line marker & see-through chuck guard included. Rotating, 45° tilting, crank-operated worktable with quick release clamp. Forced opening switch need a re-start in case of power failure. 12 spindle speeds: 340 to 2800 rpm. 3/4 HP motor.

75-030 M1  
**\$349.99**  
 reg. \$395.00

Line interrupter switch



### 14" drill presses

#75-030 M1 (bench top model) / #75-150 M1 (floor model)  
 5/8" chuck with key, laser line marker & see-through chuck guard included. Rotating, 45° tilting, crank-operated worktable with quick release clamp. Forced opening switch need a re-start in case of power failure. Built-in lamp illuminates the drilling area (bulb not included). 12 spindle speeds: 280 to 3000 rpm. 1/2 HP motor.

75-050T M1

**\$619.99**

reg. \$790.00

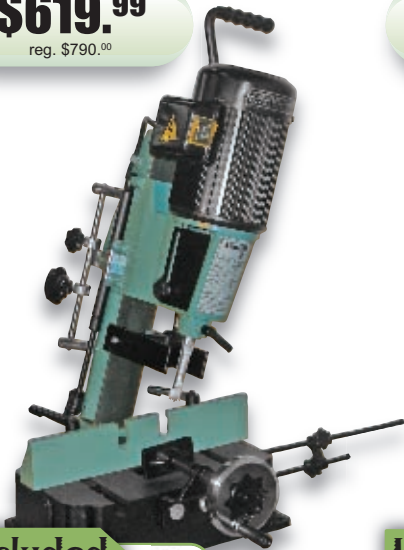

**Included**

4 Chisel & bit sets



5/16" hollow chisel mortiser

1/4", 5/16", 3/8", & 1/2" chisel & bit sets included.

Features a tilting head (30° left & right) with a 180° swivel. Includes sleeves for both 5/8" and 3/4" chisel shanks. 1/2 HP motor.

75-075 M1

**\$1,229.99**

reg. \$1,590.00



**Included**

4 Chisel & bit sets



1" hollow chisel mortiser

1/4", 3/8", 1/2", & 3/4" chisel & bit sets included.

Heavy-duty cast-iron construction. Lateral and longitudinal table movement. Tilting head and swivel fence. 1 HP motor.

75-070

**\$290.99**

reg. \$340.00



Optional closed stand for mortiser

Fits on models 75-050T & 75-075 only.

# MORTISERS

75-040 M1

**\$419.99**

reg. \$560.00



**Included**

4 Chisel & bit sets



5/16" hollow chisel mortiser

1/4", 3/8", 1/2", & 3/4" chisel & bit sets included.

Heavy-duty cast-iron construction. Adjustable workpiece stop & fence-mounted hold-down. Includes sleeves for both 5/8" and 3/4" chisel shanks. 1/2 HP TEFC motor.

75-440 M1

**\$1,699.99**

reg. \$2,200.00

13 spindle boring machine

Fully adjustable fence system.

Heavy-duty cast-iron construction, machined with precision. Open base steel stand included. Powerful 1 1/2 HP motor.

\*Drill bits not included.



Optional Blum style hinge boring attachment (Item #75-445)

**\$449.99**  
reg. \$790.00

# SHAPERS

40-250 M1

**\$1,499.99**

reg. \$2,150.00



3/4" spindle shaper

1/4" & 1/2" router bit adapters included.

2 spindle speeds with reverse: 8000 & 10,000 rpm. Magnetic switch with thermal overload protection. 3 HP motor.

40-350 M1

**\$3,499.99**

reg. \$4,500.00



1 1/4" production shaper

4 spindle speeds with reverse: 4000, 6000, 8000 & 10,000 rpm.

Magnetic switch with thermal overload protection. Built-in retractable castor system. 5 HP motor.

40-450 M1

**\$4,999.99**

reg. \$6,450.00



Independent fence micro adjustment

1 1/4" heavy-duty production shaper

5 spindle speeds with reverse: 3000, 4000, 6000, 8000 & 10,000 rpm.

Magnetic switch with thermal overload protection. 2 emergency stop buttons. 5 HP motor.

# CNC CARVING MACHINES

The next generation *i-Carver*<sup>TM</sup> offers many **new features** that make it the best value in the bench top CNC market.

## New Features include:

- New "Pause" function for added flexibility!
- New "Bordering" feature for added security!
- Variable jogging speed for more critical positioning!
- Improved ball screws for more rugged and accurate performance!
- New and improved operating system for smoother cutting operation!

**PLUS!**

All 40-915X M1 *i-Carver*<sup>TM</sup> now comes complete with:

ArtCAM Express CAD design software with training DVD! ArtCAM Express adds a whole new level of functionality to your *i-Carver*<sup>TM</sup>. Easy-to-learn design software with powerful CAD/CAM functions. Import virtually any graphic file (JPG, PNG, BMP, DXF, DWG) and easily create tool paths. Create a variety of tool paths (texturing, carving, profiling, pocketing). Customize your own textures. Over 500 3D images included that can be imported into your design and machined. ArtCAM Express software is fully supported by General CNC's technical support team.

*i-Carver*<sup>TM</sup>  
15" x 20" CNC  
carving machine

40-915X M1

**\$4,499.99**  
reg. \$5,250.00

With  
*i-Picture*<sup>TM</sup> &  
ArtCam Express  
software

**New!**

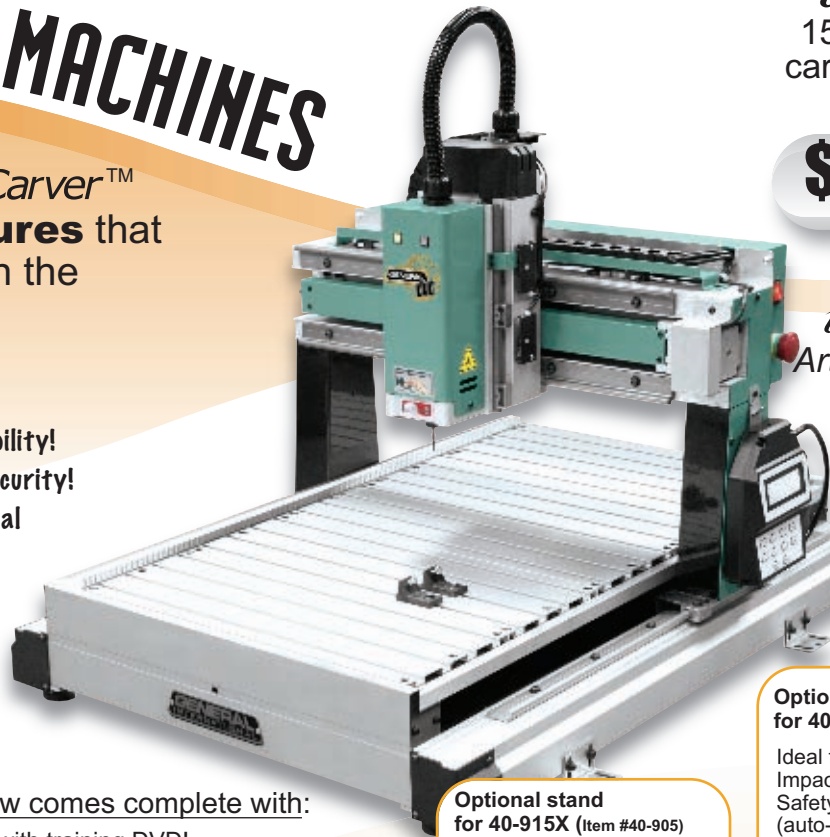

Optional safety enclosure  
for 40-915X (Item #40-919X)

Ideal for educational users.  
Impact resistant Lexan<sup>TM</sup>.  
Safety inter-lock door  
(auto-shut-off).



**\$1,159.99**  
reg. \$1,375.00

Optional stand  
for 40-915X (Item #40-905)



**\$244.99**  
reg. \$285.00

*i-Carver*<sup>TM</sup>  
13" x 18" CNC  
carving machine

40-913 M1

**\$2,299.99**  
reg. \$2,895.00

With  
& *i-Picture*<sup>TM</sup>  
software



Controller & *i-Picture*<sup>TM</sup> software included. 15,000 rpm spindle with brushless motor. Cutting speeds up to 118" per minute. Positional accuracy up to 0.001". 1/4" collet, tool kit and starter tools included. 1 year limited warranty.

Optional  
stand  
for 40-913  
(Item #40-903)  
**\$219.99**  
reg. \$270.00



Optional safety enclosure for  
40-913 (Item #40-918)

Ideal for educational users. Impact  
resistant Lexan<sup>TM</sup>. Safety inter-lock  
door (auto-shut-off).



**\$999.99**  
reg. \$1,235.00

24" x 36"  
Junior series  
CNC Routers

40-924 M1

**\$14,999.99**  
reg. \$18,700.00

With *V-Carve Pro*  
software



Easy start-up procedure and unrivalled technical support. Highly accurate pre-loaded linear bearing construction. 2 1/4 HP variable speed (8,000 to 25,000 rpm) name brand router included (router bits not included). Cutting speeds up to 200 inches per minute. Integrated on-board computer operating system with pre-loaded operating software included.

Shown  
with safety  
enclosure  
installed.



**Free\***

Safety enclosure (Item #40-926)  
A \$1,200.00 value

\*With the purchase of 40-924 M1 only.

# ROUTER TABLES

Bench top model with cast-iron table (#40-100C)



Floor model with cast-iron table (#40-200C)



## Deluxe router table kits

#40-100 Bench top / #40-200 Floor model

Heavy-duty massive router lift with 9 1/4" x 11 3/4" aluminum top plate, stable 4 post/lift screw design & chain drive lifting system controlling all 4 corners simultaneously. Fits all fixed base router motors\*. Smooth above-the-table adjustment mechanism for fast tool changes & precision bit setting. Two table sizes available in either cast-iron, MDF or Phenolic. Sturdy steel stands include easy access on/off safety switch with removable lock-out key. Floor model made of tubular steel, includes, mobility kit & adjustable levelling feet. Fence has 2 1/4" dust collection outlet & adjustable scales. Under table steel dust enclosure with access door, adjustable air vent, power cord grommet & 4" dust port with 2 1/4" branch inlet to the fence including 2 1/4" dust hose & 2 hose clamps.

\*some router models may require reducer collars/adaptors.

## Bench top model kits

40-100C (shown)

**\$889.99**

reg. \$1,110.00

With cast-iron table

Complete table kit includes:

- (1) 40-060, (1) 40-065, (1) 40-070,
- (1) 40-125 & (1) 40-130.

40-100M

**\$784.99**

reg. \$990.00

With MDF table

Complete table kit includes:

- (1) 40-060, (1) 40-065, (1) 40-047,
- (1) 40-125 & (1) 40-130.

40-100P

**\$844.99**

reg. \$1,055.00

With phenolic table

Complete table kit includes:

- (1) 40-060, (1) 40-065, (1) 40-043,
- (1) 40-125 & (1) 40-130.

## Floor model kits

40-200C (shown)

**\$1,099.99**

reg. \$1,380.00

With cast-iron table

Complete table kit includes:

- (1) 40-080, (1) 40-085, (1) 40-075,
- (1) 40-125 & (1) 40-130.

40-200M

**\$899.99**

reg. \$1,115.00

With MDF table

Complete table kit includes:

- (1) 40-080, (1) 40-085, (1) 40-049,
- (1) 40-125 & (1) 40-130.

40-200P

**\$1,019.99**

reg. \$1,275.00

With phenolic table

Complete table kit includes:

- (1) 40-080, (1) 40-085, (1) 40-045,
- (1) 40-125 & (1) 40-130.

40-043  
**\$169.99**  
reg. \$195.00  
16" x 27" phenolic table

40-047  
**\$114.99**  
reg. \$130.00  
16" x 27" MDF table

40-070  
**\$199.99**  
reg. \$249.00  
16" x 27" cast-iron table

40-065  
**\$117.99**  
reg. \$149.00  
Fence for 16" x 27" table

40-060  
**\$129.99**  
reg. \$169.99  
Stand for bench top model

40-092  
**\$9.99**  
reg. \$13.95  
Leveler bars for 9 1/4" x 11 3/4" plates or lifts

40-114  
**\$66.99**  
reg. \$79.00  
9 1/4" x 11 3/4" Phenolic insert plate

40-045  
**\$299.99**  
reg. \$345.00  
24" x 32" phenolic table

40-049  
**\$163.99**  
reg. \$185.00  
24" x 32" MDF table

40-075  
**\$364.99**  
reg. \$449.00  
24" x 32" cast-iron table

40-080  
**\$129.99**  
reg. \$169.00  
Fence for 24" x 32" table

40-085  
**\$169.99**  
reg. \$219.99  
Stand for floor model

40-115  
**\$139.99**  
reg. \$160.00  
9 1/4" x 11 3/4" aluminum insert plate

40-125  
**\$369.99**  
reg. \$449.00  
Router lift

40-312  
**\$6.29**  
reg. \$9.00  
Reducers collar for lift (fits 3 1/2" motor)

40-314  
**\$6.99**  
reg. \$9.50  
Reducers collar for lift (fits 3 1/4" motor)

40-130  
**\$78.99**  
reg. \$94.50  
Dust collection kit

40-090  
**\$27.99**  
reg. \$39.95  
Flip stop

40-099  
**\$29.99**  
reg. \$44.95  
9 piece brass template guide set

40-160  
**\$14.99**  
reg. \$19.95  
Vertical feather board

40-175  
**\$37.99**  
reg. \$59.95  
Horizontal feather board (set of 2)

# DUST COLLECTORS

Portable dust collector - 1 HP



**10-050 M1**  
**\$295.99**  
reg. \$369.00

Dust hood rotates 360°. Support arm extends to 12". Airflow capacity of 700 cfm\*. 1 HP motor.

**10-210CF M1**  
**\$1,329.99**  
reg. \$1,900.00

Dust collector with canister filter - 3 HP  
Air flow capacity 2280 cfm\*. Sound rating 85 to 95 dB. Equipped with 1 micron canister filters.



#10-210 M1

**10-210 M1**  
**\$869.99**  
reg. \$1,275.00

Dust collector  
Same features as #10-210CF M1 with washable, extra fine 2 micron filter bags replacing 1 micron canister filters.



Portable cyclone dust collector - 1 1/2 HP



**10-800CF M1**  
**\$1,179.99**  
reg. \$1,600.00

Airflow capacity 611 cfm\*. restricted. Equipped with 1 micron canister filter. Caster mounted for portability. Remote controller included. 1 1/2 HP industrial rated motor.

**10-005SCF M1**  
**\$439.99**  
reg. \$639.00

Dust collector with canister filter - 1 HP  
Air flow capacity 647 cfm\*. Sound rating 75 to 80 dB. Equipped with 1 micron canister filter.



#10-005 M1

**10-005 M1**  
**\$319.99**  
reg. \$439.00

Dust collector  
Same features as #10-005SCF M1 with washable, extra fine 2 micron filter bags replacing 1 micron canister filters.

**10-510CF M1**  
**\$2,899.99**  
reg. \$3,900.00

Dust collector with canister filter - 5 HP  
Air flow capacity 3980 cfm\*. Sound rating 93 dB. Equipped with 1 micron canister filter.



#10-510 M1

**10-510 M1**  
**\$1,999.99**  
reg. \$2,500.00

Dust collector  
Same features as #10-510CF M1 with washable, extra fine 2 micron filter bags replacing 1 micron canister filters.

"Super Turbo" air cleaning system



**10-600 M1**  
**\$459.99**  
reg. \$625.00

Airflow Capacity of 700, 900, 1250 cfm. 2 stage filtration. 5 pre-programmed timer settings (2, 4, 6, 8 hours & continuous). 1/2 HP motor.

**10-105CF M1**  
**\$639.99**  
reg. \$950.00

Dust collector with canister filter - 1 1/2 HP  
Air flow capacity 1100 cfm\*. Sound rating 80 to 85 dB. Equipped with 1 micron canister filter.



#10-105 M1

**10-105 M1**  
**\$469.99**  
reg. \$650.00

Dust collector  
Same features as #10-105CF M1 with washable, extra fine 2 micron filter bags replacing 1 micron canister filters.

**10-110CF M1**  
**\$874.99**  
reg. \$1,150.00

Dust collector with canister filter - 2 HP  
Air flow capacity 1550 cfm\*. Sound rating 80 to 90 dB. Equipped with 1 micron canister filter.



#10-110 M1

**10-110 M1**  
**\$619.99**  
reg. \$820.00

Dust collector  
Same features as #10-110CF M1 with washable, extra fine 2 micron filter bags replacing 1 micron canister filters.

\*Note: All CFM ratings tested under resistance to simulate typical shop usage.

# SAFETY IN THE WORK PLACE

## Power feeders

#20-100 M1  
**\$398.99**

reg. \$499.00

Fully adjustable. Variable speeds 6.5 to 40 fpm in forward or reverse. 1/8 HP motor.

#20-200 M1  
**\$649.99**

reg. \$800.00

3 rollers. 4 speeds: 20, 26, 33 & 43 fpm (6, 8, 10 & 13 mpm). 1/4 HP motor.

#20-220 M1  
**\$979.99**

reg. \$1,250.00

3 rollers. 4 speeds: 9.5, 15, 25 & 38 fpm (2.9, 4.5, 7.5, 11.5 mpm). 1/2 HP motor.



## Overarm blade cover system with dust collection capability

Unique design mounting bracket: pivots arm away or removes completely in seconds. 4" main boom and 3" inner boom. Flexible 3" hose connects the blade cover to the boom.

#50-EXBC10 (10") #50-EXBC14 (12" - 14")  
**\$399.99 \$469.99**

reg. \$550.00

reg. \$600.00

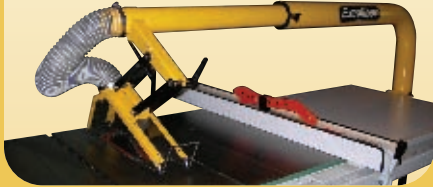

## Wood lathe guard

This Wood Lathe Guard is easily installed on the lathe bed and the height of its support column can be adjusted to suit the clearance needed for the shield depending on the size of your lathe. This device ensures complete safety against the following risks: wood chips, broken tools, dust, or any other object. Fits most wood turning lathes. Does not interfere with normal lathe use.

#25-160  
**\$264.99**

reg. \$335.00



## Magnetic switch with emergency stop & lock

- #85-110 (110 volt, 1ph, 1 HP, 8 to 11 A)
- #85-115 (110 volt, 1ph, 1/2 HP, 4.5 to 6.5 A)
- #85-120 (110 volt, 1ph, 3/4 HP, 10 to 15 A)
- #85-125 (110 volt, 1ph, 1 HP, 11 to 14 A)
- #85-210 (220 volt, 1 ph, 2 to 3 HP, 8 to 11 A)
- #85-215 (208 / 230 volt, 1 ph, 1 1/2 HP, 8 to 11 A)
- #85-220 (220 volt, 1 ph, 2 HP, 11 to 14 A)
- #85-225 (220 volt, 1 ph, 2 to 3 HP, 14 to 17 A)
- #85-230 (220 volt, 3 ph, 2 HP, 4.5 to 6.5 A)
- #85-235 (220 volt, 1 ph, 2 to 3 HP, 11 to 14 A)
- #85-240 (208 / 230 volt, 1 ph, 3 HP, 10 to 15 A)
- #85-245 (220 volt, 1 ph, 3 HP, 14 to 17 A)
- #85-255 (220 volt, 3 ph, 5 HP, 11 to 14 A)
- #85-260 (220 volt, 1 ph, 3.5 to 5 HP, 14 to 17 A)
- #85-265 (220 volt, 1 ph, 6 HP, 21 to 25 A)
- #85-270 (220 volt, 3 ph, 5 1/2 HP, 14 to 17 A)
- #85-275 (220 volt, 3 ph, 7 1/2 HP, 17 to 21 A)
- #85-280 (220 volt, 3 ph, 3 HP, 8 to 11 A)
- #85-285 (220 volt, 1 ph, 5 HP, 21 to 25 A)
- #85-610 (600 volt, 3 ph, 3 HP, 4.5 to 6.5 A)
- #85-615 (600 volt, 3 ph, 2 to 3 HP, 2.9 to 4 A)
- #85-620 (600 volt, 3 ph, 5 to 5 1/2 HP, 4.5 to 6.5 A)
- #85-625 (600 volt, 3 ph, 7 1/2 HP, 6 to 8 A)



**\$149.00**

reg. \$195.00

## Set of 2 8" plastic push sticks



**\$6.99**

reg. \$9.45

## Grounding kit for dust collectors



**\$16.99**

reg. \$21.45

## 4 piece safety kit



**\$16.99**

reg. \$25.45

## Electronic earmuffs



**\$39.99**

reg. \$63.45

## Heavy-duty drill press chuck guard

- #70-152 - 52 mm (for 34-01, 34-02, 34-10, 34-111 & 34-121)
- #70-155 - 55 mm (for 75-025, 75-030, 75-125, 75-150, 75-160 & 75-550)
- #70-165 - 65 mm (for 75-100 & 75-200)
- #70-175 - 75 mm (for 75-260, 75-500 & 75-700)



**\$149.99**

reg. \$185.00

## Drill press chuck guard

- #70-115 A - 55 mm
- #70-115 B - 65 mm
- #70-115 C - 75 mm



**\$15.99**

reg. \$24.20

**\$19.99**

reg. \$29.45

## Dust collection fire protection cage

Modular panel design for ease of assembly. All steel construction - 100% non flammable. Open top for easy hose access.

#10-420  
54 1/8" x 59 1/4" x 95"  
**\$1,299.99**

reg. \$1,700.00

#10-430  
80 3/16" x 59 1/4" x 95"  
**\$1,849.99**

reg. \$2,050.00

#10-450  
80 3/16" x 85 3/8" x 95"  
**\$2,099.99**

reg. \$2,390.00



50-166

**\$189.99**

reg. \$229.00

### Flexible expandible roller stand

Maximum load capacity of 200 lb. Adjustable height from 23" to 36". 9 nickel-plated 1 1/2" x 13 3/4" rollers. 50" maximum expanded length. 14 3/4" compacted length. 4" wheels with locking foot levers.



50-167S

**\$329.99**

reg. \$395.00

### Flexible expandible 2-way heavy-duty roller stand

Maximum load capacity of 400 lb. Adjustable height from 24 1/4" to 37". 9 nickel-plated 2 1/4" x 20" 2-way rollers. 51 1/2" maximum expanded length.



Added value



95-060

**\$779.99**

reg. \$990.00

### 60" x 30" oak workbench with steel legs

Solid 1" thick table top with 3" apron. Includes both front and end vises with a double row of bench dog holes in the table for each vise. Large storage drawer. Sturdy adjustable height (33"- 39") steel legs.

Free\*

82 pc plastic peg board shop organizer set (Item #95-082)

A \$49.00 value

\*With the purchase of 95-060 only.

Tools & parts not included



50-025

**\$67.99**

reg. \$95.00

### Universal mobile base

500 lb capacity Strong 3" wheels. Rubber levelling feet (2). Adjustment in 1" increments.



10-300 M1

**\$369.99**

reg. \$465.00

### Wet / dry vacuum cleaner Stainless steel tank

10 gallon capacity. 2 speed motor. Rated for heavy-duty maintenance and janitorial use. 2 stage air filtration. 1 1/2 HP motor.



99-300

**\$54.99**

reg. \$69.95

### The lumber store

Lumber shelving and storage system. Easy installation. 6 level multipurpose racking. Sturdy steel construction. For use in garages, workshops, storage sheds, on walls or on fences. Load capacity of 110 lbs (50 kg) per level.

Included

#10-306

#10-309

#10-310

#10300-11B

#10-314

#10-323

#10300-35B

#10-334

#10-332

50-320, M1, M2, M3

**\$11,999.99**

reg. \$14,450.00

Excalibur blade cover / Dust hood



Maintenance-free round guide rail system

Solid cast fence body with fence micro-adjuster

### 14" panel saw, with 11 ft (3200 mm) sliding table

Independent motor for main blade and scoring blade.

Large sliding table with anodized aluminum parts for longer life. 0° to 45° left or right crosscut fence adjustment with easy-read degree scale for accurate miter cuts. Magnetic switch with thermal overload protection. Heavy-duty rip fence system with cast-iron main body and all steel guide rail for rock solid positioning. 5 HP (M1) or 7 1/2 HP (M2, M3) main motor.