

# STAINLESS STEELS FOR EVAPORATORS AND CONCENTRATORS

---

A DESIGNERS' HANDBOOK SERIES  
N° 9026



Produced by  
AMERICAN IRON  
AND STEEL INSTITUTE

Distributed by  
NICKEL  
INSTITUTE

  
*knowledge for a brighter future*

# **STAINLESS STEELS FOR EVAPORATORS AND CONCENTRATORS**

A DESIGNERS' HANDBOOK SERIES  
Nº 9026

Originally, this handbook was published in 1981 by the Committee of Stainless Steel Producers, American Iron and Steel Institute.

The Nickel Institute republished the handbook in 2020. Despite the age of this publication the information herein is considered to be generally valid.

Material presented in the handbook has been prepared for the general information of the reader and should not be used or relied on for specific applications without first securing competent advice.

The Nickel Institute, the American Iron and Steel Institute, their members, staff and consultants do not represent or warrant its suitability for any general or specific use and assume no liability or responsibility of any kind in connection with the information herein.

---

**Nickel Institute**

communications@nickelinstitute.org  
www.nickelinstitute.org

# STAINLESS STEELS FOR EVAPORATORS/ CONCENTRATORS

---

## CONTENTS

PREFACE .....	3
INTRODUCTION.....	4
EVAPORATOR DESIGN.....	4
STAINLESS STEEL BASICS .....	10
Identification.....	10
General-Purpose Types .....	10
Guidelines for Selection .....	10
High-Temperature Properties .....	15
Fabrication .....	19
Joining .....	20
REFERENCES .....	22

## PREFACE

The concentration of liquids or the removal of moisture from products by evaporation are process operations utilized in many industries, such as food and beverage, chemical and petrochemical, pulp and paper, pharmaceutical, water treatment, etc. While evaporation technology has been around for many years, it is by no means a static technology. Changes are being effected to conserve energy and to accommodate pollution control requirements.

For example, process engineers are making adjustments in operating temperatures and pressures. New evaporator units are being added to existing systems, or complete evaporator trains are being replaced with more efficient systems. Complicating the problem is pollution control. Waste streams once simply discharged to a sewer are being closed up, increasing the concentration of aggressive elements within the plant. The net result is a greater incidence of corrosion and, sometimes, premature equipment failure.

Plant and process engineers are finding material selection to be more critical. Where carbon or low-alloy steels once provided satisfactory service, engineers are finding it necessary to upgrade to more corrosion-resistant materials, such as stainless steels.

Stainless steels have been and will continue to be used extensively in evaporator systems in many industries. They provide excellent resistance to corrosion to assure long trouble-free equipment operation and to prevent contamination of product streams. Stainless steels resist extremes in temperature, providing excellent strength properties from cryogenic lows up to highs of approximately 2000°F. Stainless steels resist the buildup of scale and deposits on heat exchange surfaces, and they are readily cleaned.

The purpose of this publication is to help process engineers, designers, specifiers and purchasing officials better understand, select, use, and care for the corrosion and high-temperature-resistant stainless steels that are finding wider application in evaporator service.

# INTRODUCTION

While the purpose of this publication is to discuss stainless steels, readers will find the following descriptions of typical evaporator types helpful in setting the stage. It is important to keep in mind that stainless steels are used in all of these systems, but that the proper selection of a specific alloy depends upon the availability of adequate information on service conditions.

## EVAPORATOR DESIGN

Following is a description of several typical types of evaporators from a simple "steam kettle" to the more complex rising/falling film type. The common factor among all of these types is the addition of heat—generally indicated by the input of steam—and the separation of product and vapor. While shown as single units, evaporators are frequently installed in a multiplicity of units, or trains.

### Batch Pan

The batch pan jacketed evaporator is one of the earliest concentrator designs that, although somewhat outdated, still finds limited application in food processing. As shown in Figure 1, it consists of a vessel heated by either an external jacket or internal coils. Overhead vapor is condensed in a heat exchanger, which provides improved energy utilization.

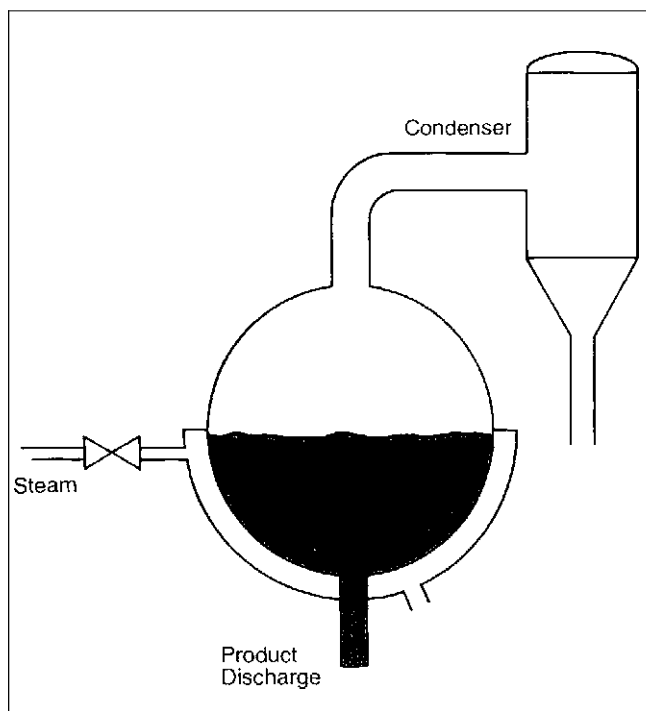

Figure 1 Jacketed Batch Evaporator

### Natural Circulation

Evaporation by natural circulation is achieved through the use of a short tube bundle within the batch pan or by having an external shell and tube heater outside of the main vessel as illustrated by Figure 2. The external heater has the advantage that its size is not dependent upon the size or shape of the vessel itself. As a result, larger evaporation capacities may be obtained. The most common application for this type of unit probably is as a reboiler at the base of a distillation column.

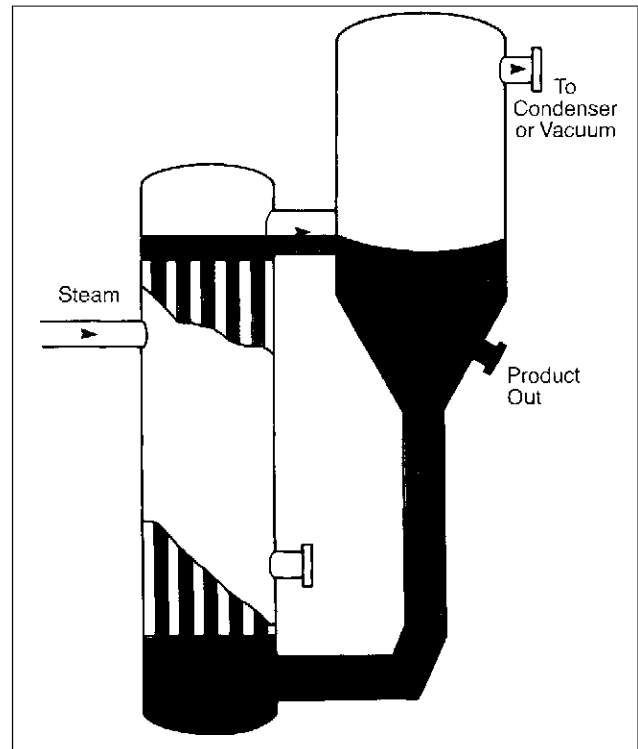
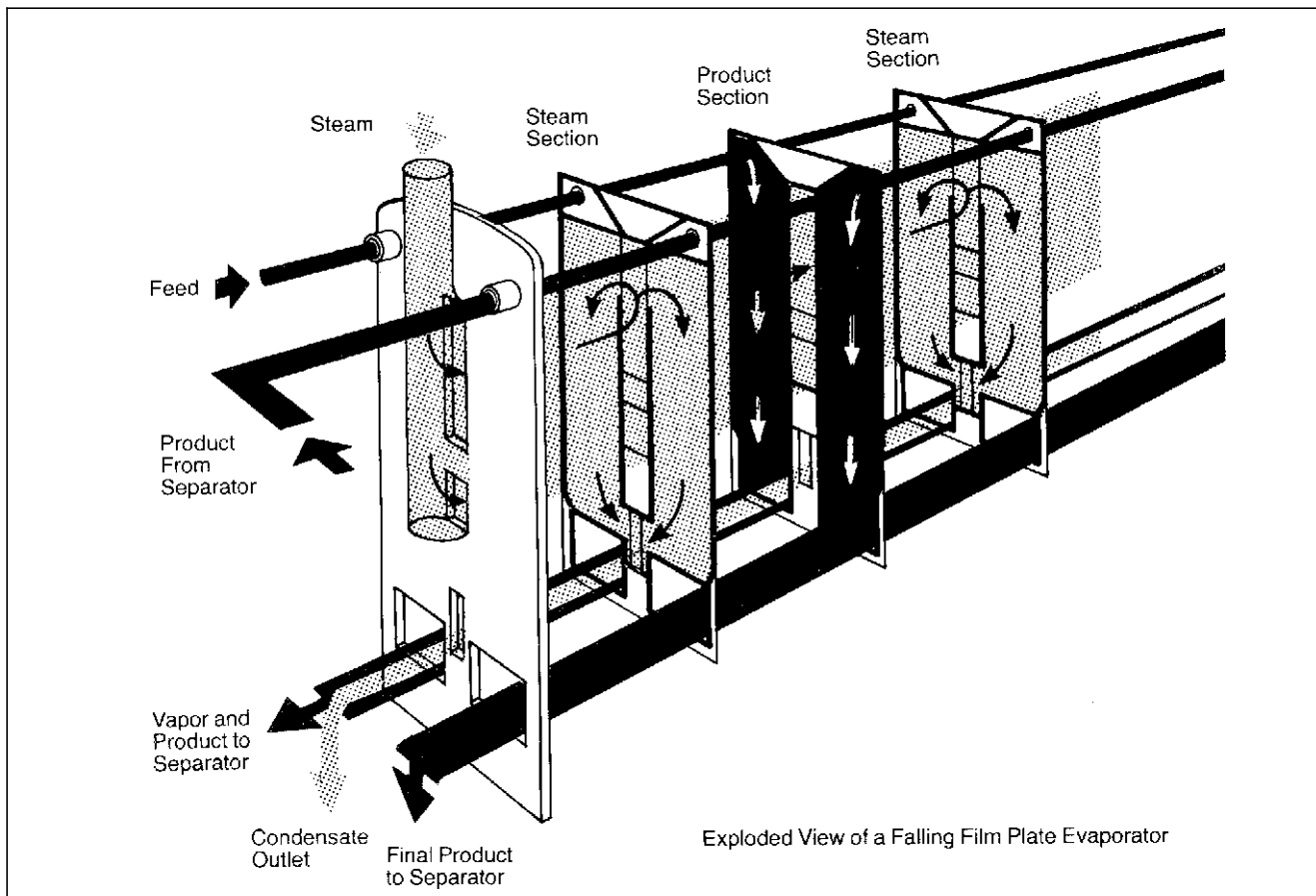

Figure 2 Natural Circulation



Photograph of high-efficiency four-effect tubular falling film evaporator shows top of calandria with bonnets open. Perforated distribution plates (inside effect in foreground) channel fluids evenly to two-inch diameter stainless steel tubes. For food processing, generally the entire evaporator is stainless steel.

Photograph provided by: APV Company, Inc., Tonawanda, New York



*Drawing is an exploded view of a falling film plate evaporator, which is ideally suited for heat-sensitive liquids such as delicately flavored juices. A typical evaporator of this design can remove water at 55,000 to 60,000 pounds per hour. Photograph shows typical*

*triple effect, four stage falling film plate evaporator for concentrating citrus juices. Sanitary applications require stainless steels.*

*Drawing and photograph provided by. APV Company, Inc., Tonawanda, New York*

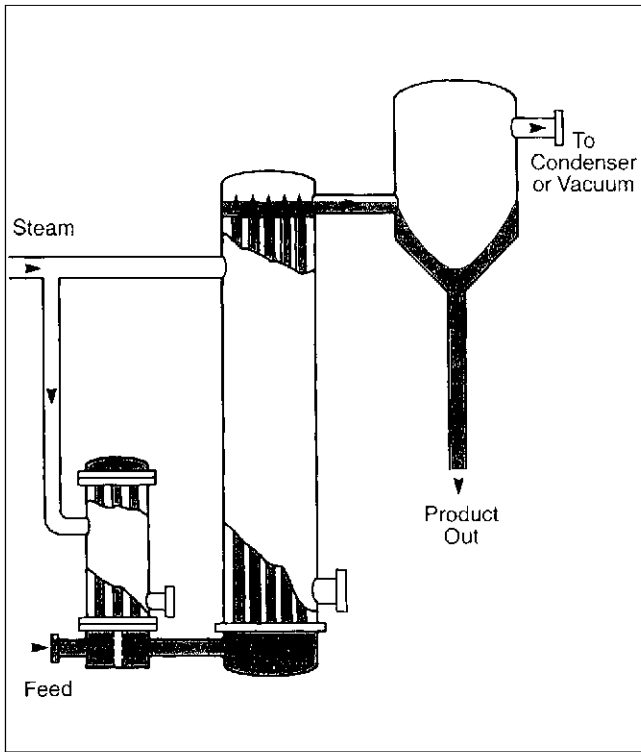

Figure 3 Rising Film

## Rising Film

The first of the modern types of evaporators is the rising film unit although its use by industry goes back to the early 1900's. The rising film principle uses a vertical tube with steam condensing on its outside surface (Figure 3). Liquid on the inside of the tube is brought to a boil, the vapor generated forming a core in the center of the tube. As the fluid moves up the tube, more vapor is formed resulting in a higher central core velocity that forces the remaining liquid to the tube wall. Higher vapor velocities, in turn, result in a thinner and more rapidly moving liquid film. This provides higher heat transfer coefficients and shorter product residence time.

## Falling Film

Following development of the rising film principle, it took almost a further half century for a falling film evaporation technique to be perfected (Figure 4). The main problem was one of designing an adequate system for the even distribution of liquid to each of the tubes. Distribution in its forerunner, the rising film evaporator, was easy as the bottom bonnet of the calandria was always pumped full of liquid, thus allowing equal flow to each tube.

While each manufacturer has his own technique, falling film distribution generally is based around a perforated plate positioned above the top tube plate of the calandria. Spreading of liquid to each tube sometimes is further enhanced by generating flash vapor at this point. The falling film evaporator does have the advantage that the film is 'going with gravity' instead of against it, resulting in a thinner, faster moving film and giving rise to even shorter product contact time and a further improvement in heat transfer values.

The rising film unit normally needs a driving force or temperature difference across the heating surface of at least 25°F to establish a well developed film whereas the falling film evaporator does not have a driving force limitation. This permits a greater number of evaporator effects to be used within the same overall operating limits.

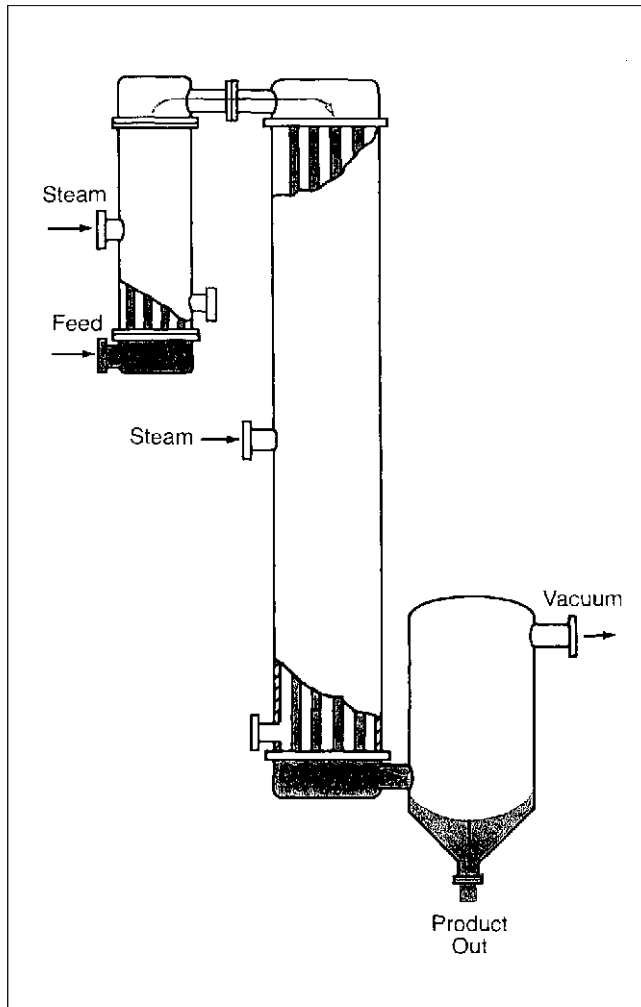

Figure 4 Falling Film Tubular

## Rising/Falling Film

As illustrated by Figure 5, the rising/falling film evaporator has the advantages of the ease of liquid distribution of the rising film unit coupled with lower head room requirements. The tube bundle is approximately half the height of either a rising or falling film evaporator and the vapor/liquid separator is positioned at the bottom of the calandria.

## Forced Circulation

The force circulation evaporator (Figure 6) was developed for processing liquors which are susceptible to scaling or crystallizing. Liquid is circulated at a high

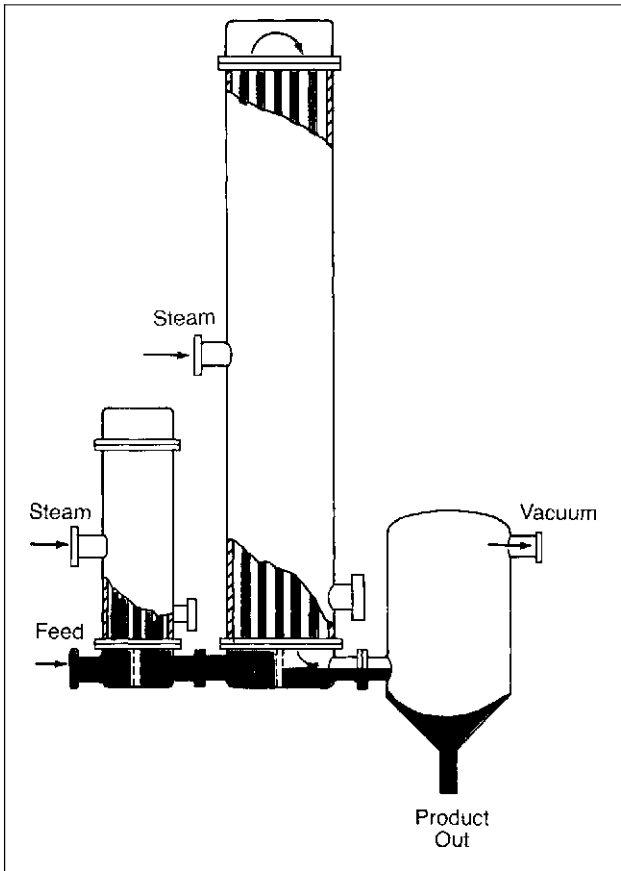

**Figure 5 Rising/Falling Film Tubular**

rate through the heat exchanger, boiling being prevented within the unit by virtue of a hydrostatic head maintained above the top tube plate. As the liquid enters the separator where the absolute pressure is slightly less than in the tube bundle, the liquid flashes to form a vapor.

The main applications for a forced circulation evaporator are in the concentration of soluble materials, crystallizing duties, and in the concentration of thermally degradable materials which result in the deposition of solids. In all cases, the temperature rise across the tube bundle is kept as low as possible, generally in the region of three to five degrees. This results in a recirculation ratio as high as 200 to 330 pounds of liquor per pound of water evaporated. These high recirculation rates result in high liquor velocities through the tubes which help to minimize the build up of deposits or crystals along the heating surface.

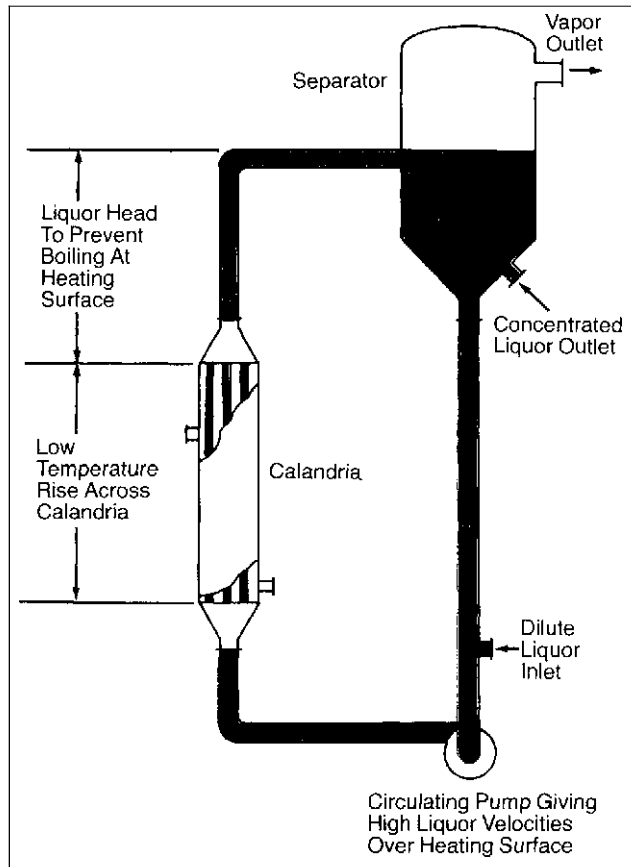

**Figure 6 Forced Circulation**

## Wiped Film

The wiped or agitated thin film evaporator depicted in Figure 7 has limited applications and is confined mainly to the concentration of very viscous materials and the stripping of solvents down to very low levels. Feed is introduced at the top of the evaporator and is spread by wiper blades on to the vertical cylindrical surface inside the unit. Evaporation of the solvent takes place as the thin film moves down the evaporator wall. The heating medium normally is high pressure steam or oil. A high-temperature heating medium generally is necessary in

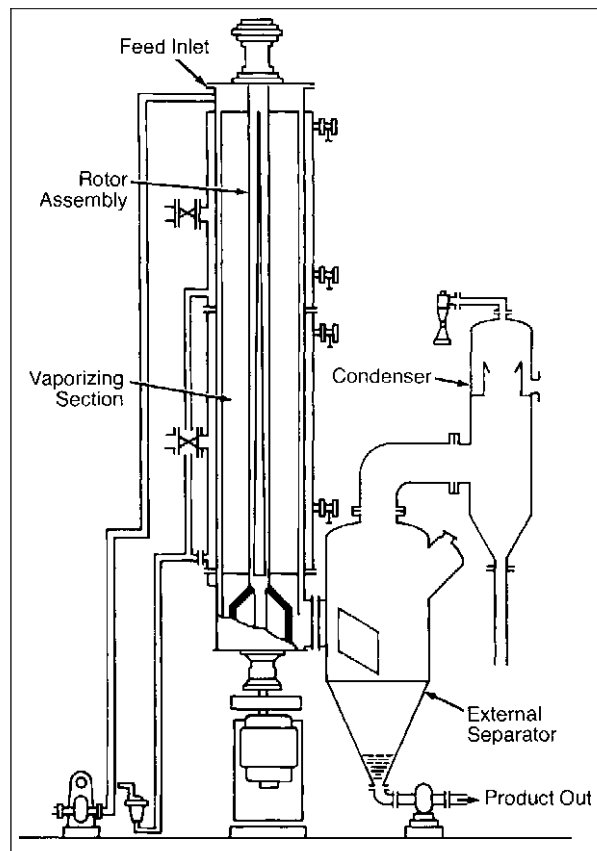

**Figure 7 Wiped Film**

order to obtain a reasonable evaporation rate since the heat transfer surface available is relatively small as a direct result of its cylindrical configuration.

The wiped film evaporator is very satisfactory for its limited applications. However, in addition to its small surface area it also has the disadvantage of requiring moving parts such as the wiper blades which, together with the bearings of the rotating shaft, need periodic maintenance.

## Plate Evaporators

In addition to the widely used tubular evaporator styles just described, there are also available a number of evaporator systems in a plate-type design. For example, a typical *rising/falling film plate-type* evaporator is illustrated in Figure 8. The surface area is comprised of four different types of plates which constitute one plate unit. Steam and product pass between alternate plates, the first product plate being a rising film plate and the second being a falling film plate.

A plate evaporator has a number of advantages over its tubular counterpart. Since it is more compact and takes up less head room, in many cases it will fit within an existing building with overhead restrictions as low as

12 or 13 feet. It also has the capability of being easily expanded merely by the addition of more plate units, and needs no supporting steelwork since all components sit directly on the ground. If necessary, it is a very simple operation to open the unit to inspect the heat transfer surface during a cleaning cycle.

A relatively new development, the *falling film plate evaporator* has been in commercial operation for a period of only three to four years. One of the disadvantages of the rising/falling film evaporator has been the limitation of its capacity to the region of 30,000 to 35,000 pounds per hour of water removal. The new falling film plate evaporator design extends this evaporative capacity to a range of 55,000 to 60,000 pounds per hour.

In all of the aforementioned evaporator designs, stainless steels are important construction materials for heat exchanger tubing or plates, tube sheets, structural supports, vessels or calandrias, distribution plates, piping, pumps and valves. Stainless steels have excellent resistance to corrosion and to the effects of high-temperature service, they have excellent heat transfer characteristics, they have excellent fabrication characteristics, and they are readily available in the forms and alloy compositions necessary to meet a wide range of service requirements.

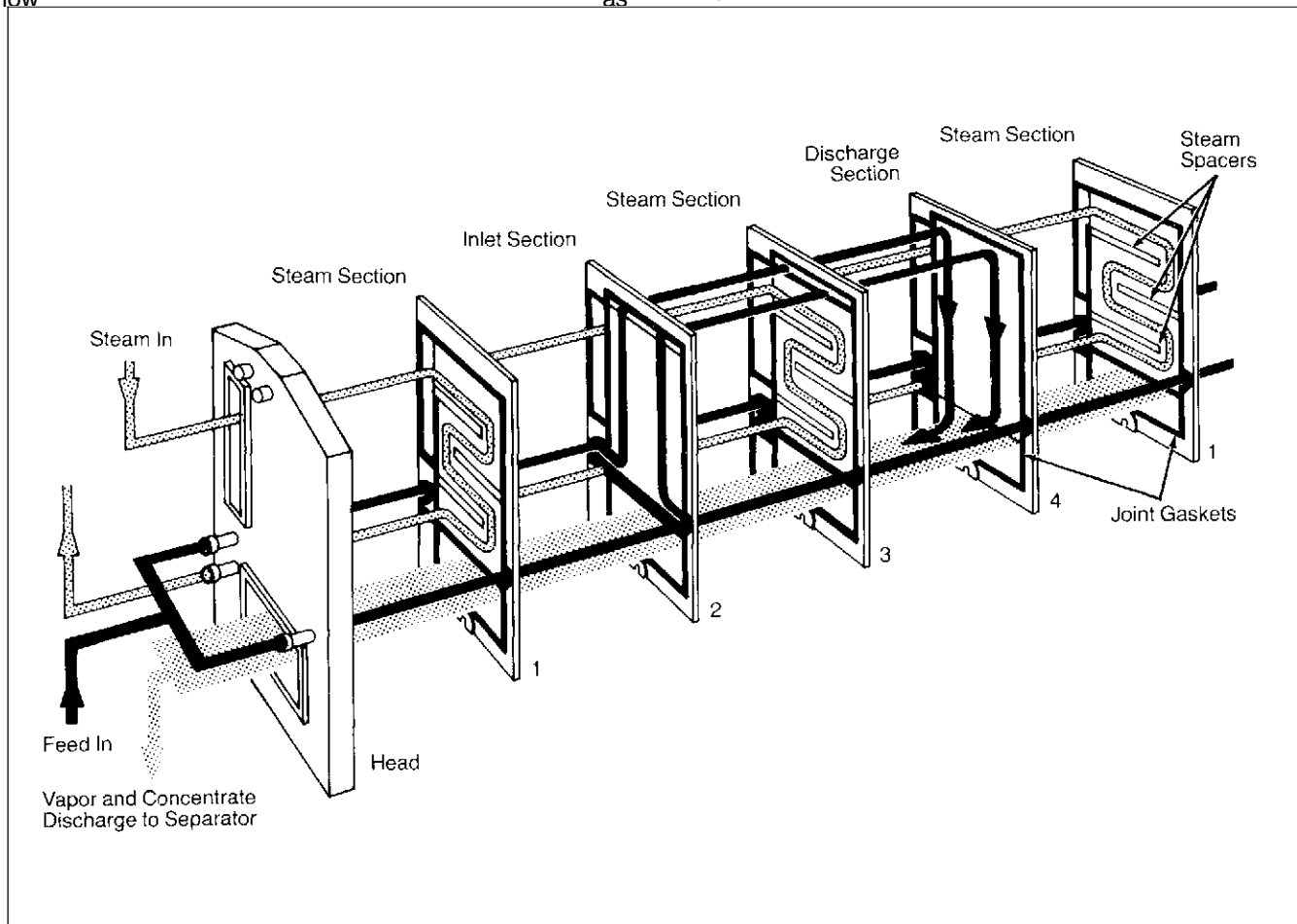
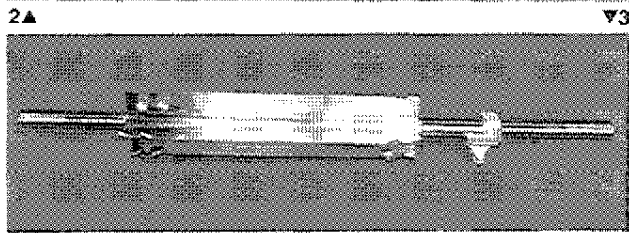
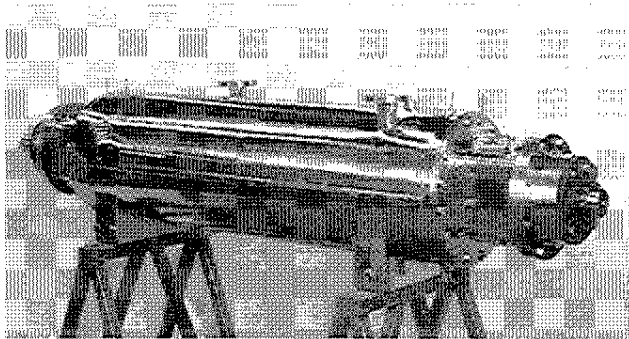
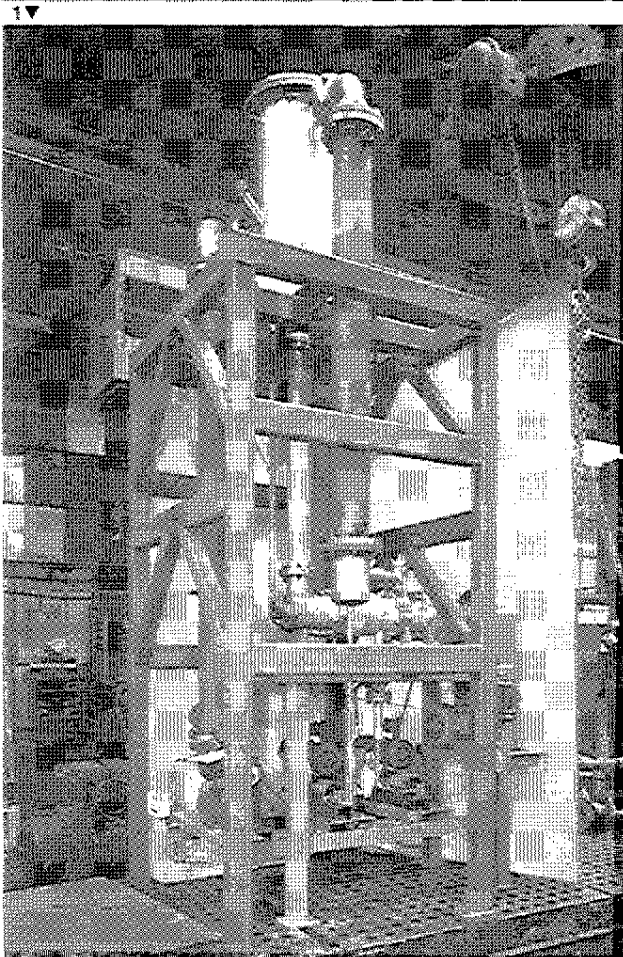
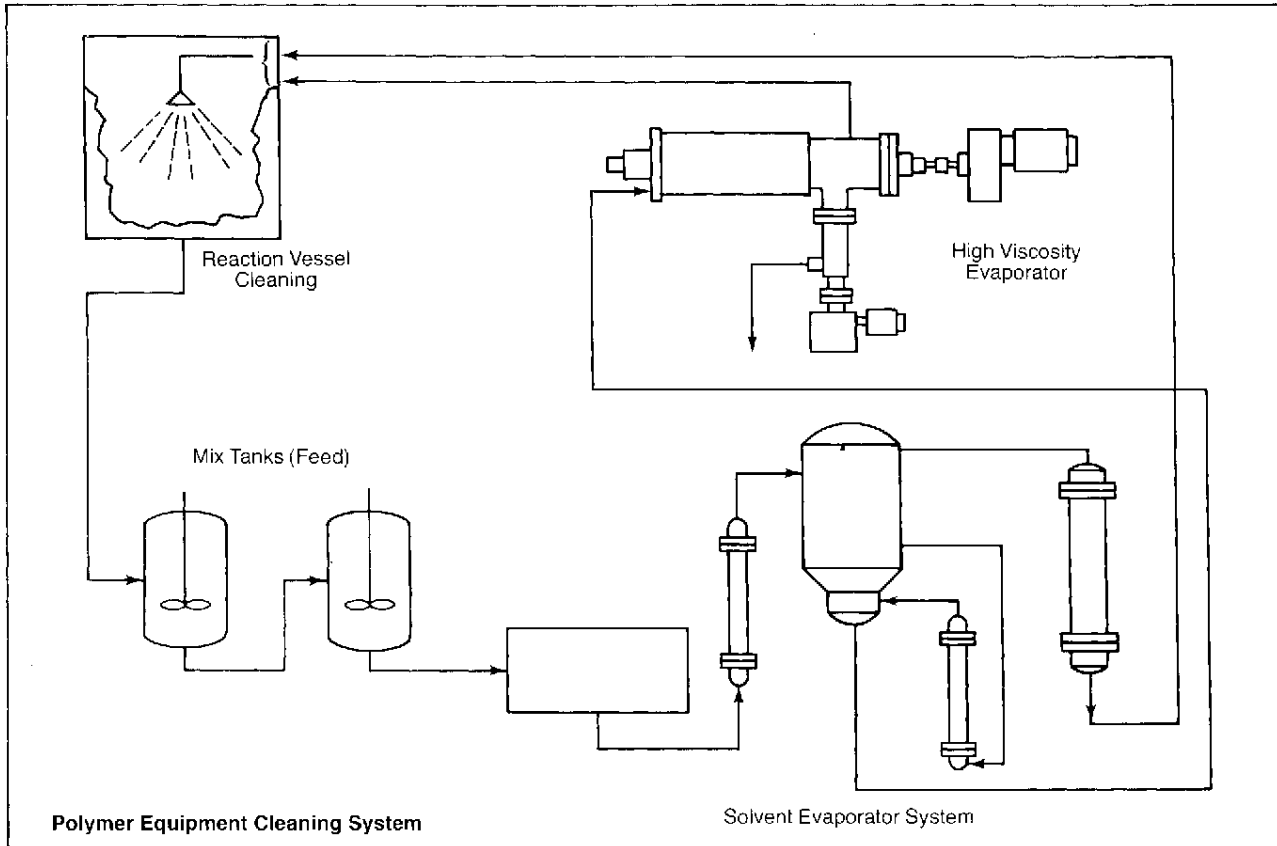

Figure 8 Rising/Falling Film Plate Evaporator





The diverse requirements of pollution control have led to some highly specialized applications for evaporator equipment. For example, the drawing shows a typical flow diagram of a system for cleaning reactors used by polymer manufacturers or processors. Photograph 1 shows the first evaporator system. Photographs 2 and 3 show high viscosity evaporator in more detail. It is essentially a wiped-film evaporator. Stainless steels provide contamination-free environment and good cleanability.

Drawing and photographs provided by: Artisan Industries, Inc., Waltham, Massachusetts

# STAINLESS STEEL BASICS

Stainless steels are iron-base alloys containing 10.5 percent or more chromium. They have been used for many industrial, architectural, chemical, and consumer applications for almost a half century. Currently, there are being marketed a total of 57 stainless steels designated by American Iron and Steel Institute as AISI-numbered alloys. Also commercially available are many proprietary stainless steels with special characteristics.

## Identification

Three general classifications are used to identify stainless steels. They are:

1. Metallurgical structure.
2. The AISI numbering system: namely 200, 300, and 400 Series numbers.\*
3. The new Unified Numbering System, which was developed by ASTM and SAE to apply to all commercial metals and alloys.

Following is a description of these classifications:

**Austenitic** stainless steels containing chromium and nickel are identified as AISI 300 Series types. Alloys containing chromium, nickel and manganese, are identified as AISI 200 Series types.

There are 31 stainless steels in the austenitic group having different compositions and properties, but many common characteristics. They can be hardened by cold working, but not by heat treatment. Annealed, all are nonmagnetic, although some may become slightly magnetic by cold working. They have excellent corrosion resistance and unusually good formability, and they increase in strength as a result of cold work.

Type 304 (frequently referred to as 18-8 stainless) is the most widely used alloy of the austenitic group. It has a nominal composition of 18 percent chromium and 8 percent nickel. Its UNS number is S30400.

**Ferritic** stainless steels are straight-chromium AISI 400 Series types that cannot be hardened by heat treatment, and only moderately hardened by cold working. They are magnetic, have good ductility and good resistance to corrosion and oxidation. Type 430 (S43000) is the most widely used stainless steel of the ferritic group.

**Martensitic** stainless steels are straight-chromium AISI 400 Series types that are hardenable by heat treatment. They have fairly good ductility, and some can be heat treated to tensile strengths exceeding 200,000 psi (1379 MPa).

Type 410 (S41000) is the most widely used alloy of the martensitic group.

**Precipitation-hardening** stainless steels are chromium-nickel types, some containing other alloying

elements, such as copper or aluminum. They can be hardened by solution treating and aging to high strength.

## General-Purpose Stainless Steels

While there is a wide variety of stainless steels available and in use today, only three types serve the vast majority of applications. Characterized as "general-purpose" stainless steels, they are the aforementioned Types 304, 430, and 410. Virtually all other stainless steels are variations of these grades, each developed to meet certain requirements of fabrication or end use. Following is a description of the three basic types:

**Type 304** serves a wide range of applications. It withstands ordinary rusting in architecture, it is immune to food-processing environments (except possibly for high-temperature conditions involving high acid and chloride contents), it resists organic chemicals, dyes, and a wide variety of inorganic chemicals. Type

304 resists nitric acid well and sulfuric acids at moderate temperature and concentrations. It is used extensively for storage of liquified gases, equipment for use at cryogenic temperatures, appliances and other consumer products, kitchen equipment, hospital equipment, transportation, and waste-water treatment.

**Type 316** is a variation of Type 304 containing slightly more nickel and 2-3 percent molybdenum, thus giving it better resistance to corrosion than Type 304 – especially in chloride environments that tend to cause pitting. Type 316 was developed for use in sulfite pulp mills because it resists sulfuric acid compounds. Its use had been broadened, however, to handling many chemicals in the process industries.

**Type 317** contains 3-4 percent molybdenum and more chromium than Type 316 for even better resistance to pitting.

**Type 430** has lower alloy content than Type 304 and is used for highly polished trim applications in mild atmospheres. It is also used in nitric acid and food processing.

**Type 410** has the lowest alloy content of the three general-purpose stainless steels and is selected for highly stressed parts needing the combination of strength and corrosion resistance, such as pump shafts, valve stems, or fasteners. Type 410 resists corrosion in mild atmospheres, steam, and many mild chemical environments.

Table 1 shows the chemical composition ranges of the above-mentioned stainless steels and other alloys that might be considered for evaporator service.

## GUIDELINES FOR SELECTION

Stainless steels are engineering materials with good corrosion resistance, strength, and fabrication characteristics. They can readily meet a wide range of design criteria—load, service life, low maintenance, etc. Selecting the proper stainless steels for evaporator service essentially means weighing four elements. In order of importance, they are:

1. **Corrosion or Heat Resistance** – the primary reason for specifying stainless. The specifier

\*Note: This designation system refers only to the chemical composition ranges and limits of these grades.

**TABLE 1  
FREQUENTLY USED STAINLESS STEELS**

AISI Type (UNS No.) [Trade Name]	Chemical Analysis % (Max. unless noted otherwise)									Nominal Mechanical Properties (1) (Annealed Sheet unless noted otherwise)						
	C	Mn	P	S	Si	Cr	Ni	Mo	Other	Tensile Strength		Yield Strength (0.2% offset)		Elongation in 2" (50.80mm) %	Hardness (Rockwell)	Product Form
										ksi	MPa	ksi	MPa			
<b>AUSTENITIC</b>																
304 (S30400)	0.08	2.00	0.045	0.030	1.00	18.00/ 20.00	8.00/ 10.50				84	579	42	290	55	B80
304L (S30403)	0.030	2.00	0.045	0.030	1.00	18.00/ 20.00	8.00/ 12.00				81	558	39	269	55	B79
309 (S30900)	0.20	2.00	0.045	0.030	1.00	22.00/ 24.00	12.00/ 15.00				90	621	45	310	45	B85
310 (S31000)	0.25	2.00	0.045	0.030	1.50	24.00/ 26.00	19.00/ 22.00				95	655	45	310	45	B85
316 (S31600)	0.08	2.00	0.045	0.030	1.00	16.00/ 18.00	10.00/ 14.00	2.00/ 3.00			84	579	42	290	50	B79
316L (S31603)	0.03	2.00	0.045	0.030	1.00	16.00/ 18.00	10.00/ 14.00	2.00/ 3.00			81	558	42	290	50	B79
317 (S31700)	0.08	2.00	0.045	0.030	1.00	18.00/ 20.00	11.00/ 15.00	3.00/ 4.00			90	621	40	276	45	B85
317L (S31703)	0.030	2.00	0.045	0.030	1.00	18.00/ 20.00	11.00/ 15.00	3.00/ 4.00			86	593	38	262	55	B85
321 (S32100)	0.08	2.00	0.045	0.030	1.00	17.00/ 19.00	9.00/ 12.00		5xC Ti(min)		90	621	35	241	45	B80
329 (S32900)	0.10	2.00	0.040	0.030	1.00	25.00/ 30.00	3.00/ 6.00	1.00/ 2.00			105	724	80	552	25	230 (Strip) (Brinell)
330 (N33000)	0.08	2.00	0.040	0.030	0.75/ 1.50	17.00/ 20.00	34.00/ 37.00		0.10 Ta. 0.20 Cb		80	552	38	262	40	B80
347 (S34700)	0.08	2.00	0.045	0.030	1.00	17.00/ 19.00	9.00/ 13.00		10xC Cb+Ta (min)		95	655	40	276	45	B85
[20Cb-3]* (N08020)	0.06	2.00	0.035	0.035	1.00	19.00/ 21.00	32.50/ 35.00	2.00/ 3.00	3.00/ 4.00Cu		100	689	50	345	40	B85
[6X]*	0.035	2.00	0.030	0.015	0.75	20.00/ 22.00	23.50/ 25.50	6.00/ 7.00			93	641	45	310	46	B80
<b>FERRITIC</b>																
430 (S43000)	0.12	1.00	0.040	0.030	1.00	16.00/ 18.00					75	517	50	345	25	B85
[S43035]* [Type 439]	0.07	1.00	0.04	0.03	1.00	17.00/ 19.00	0.50		12xC Ti(min)/ 1.10 0.15Al		65	450	30	205	22	B88
444 (S44400)*	0.025	1.00	0.040	0.030	1.00	17.5/ 19.5	1.00	1.75/ 2.50	0.025N Ti+Cb= 0.20+4(C+N)(min) 0.80(max)		60	415	45	310	20	B95
[S44625]* [Ebrite 26-1]	0.010	0.40	0.020	0.020	0.40	25.00/ 27.50	0.50	0.75/ 1.50	0.015N 0.20Cu		65	450	40	275	22	B90
[S44626]* [26-1Ti]	0.06	0.75	0.040	0.020	0.75	25.00/ 27.00	0.50	0.75/ 1.50	0.04N 0.20-1.00Ti 7x(C+N)(min)		68	470	45	310	20	B95
[S44700]* [29-4]	0.010	0.30	0.025	0.020	0.20	28.0/ 30.0	0.15	3.5/ 4.2	0.15Cu 0.20N C+N=0.025(max)		80	550	60	415	20	C20
[S44800]* [29-4-2]	0.010	0.30	0.025	0.020	0.20	28.0/ 30.0	2.0/ 2.5	3.5/ 4.2	0.15Cu 0.020N C+N=0.025(max)		80	550	60	415	20	C20

Source: AISI Steel Products Manual, Stainless and Heat Resisting Steels, December 1974, except as noted otherwise.

\*Source: ANSI/ASTM A240-78a

(1) The mechanical property values for all ferritic stainless steels, except Type 430, are minimum values according to ANSI/ASTM A 240-78a

needs to know the nature of the environment and the degree of corrosion or heat resistance required.

2. **Mechanical Properties** – with particular emphasis on strength at room, elevated, or low temperature. Generally speaking, the combination of corrosion resistance and strength is the basis for selection.
3. **Fabrication Operations** – and how the product is to be made is a third-level consideration. This includes forging, machining, forming, welding, etc.
4. **Total Cost** – To put everything into proper perspective, a total value analysis is appropriate that will consider not only material and production costs, but the cost-saving benefits of a maintenance-free product having a long life expectancy.

## Corrosion Resistance

Chromium is the alloying element that imparts to stainless steels their corrosion-resistance qualities by combining with oxygen to form a thin, tenacious, transparent chromium-oxide protective film on the surface. In the event that the protective (passive) film is disturbed or even destroyed, it will—in the presence of oxygen in the environment to which it is exposed—reform and continue to give maximum protection. Accordingly, it is generally accepted that oxidizing environments are good for stainless steels, while reducing environments are rather difficult for stainless steels.

The protective film is stable and protective in normal atmospheric or mild aqueous environments. It is improved for use in more aggressive environments by higher amounts of chromium, and by nickel, molybdenum, and other alloying elements such as found in the higher-alloyed stainless steels. Chromium improves film stability, molybdenum and chromium increase resistance to chloride penetration, and nickel improves film resistance in strong acid environments.

When stainless steels are candidate materials for any application, the concern is with the corrosive nature of the environment. Many variables characterize a corrosive environment—i.e., chemicals and their concentration, atmospheric conditions, temperature, time, etc. It is beyond the scope of this booklet to discuss all aspects of material selection for corrosive service. However, provided in the following discussion is a brief description of corrosion terms frequently encountered in evaporator applications. Readers should be conversant with these terms and their implication because if materials are not properly applied, these types of corrosion are likely to occur.

**Pitting** occurs when the protective film breaks down in small isolated spots, such as when halide salts contact the surface. Once started, the attack may accelerate because of differences in electrical potential between the large area of passive surface vs. the active pit.

Pitting in stainless steels is avoided in many environments by using Type 316 or other alloys containing molybdenum.

**Crevice corrosion** results from local differences in oxygen concentration associated with deposits on the metal surface, gaskets, lap joints, or crevices under

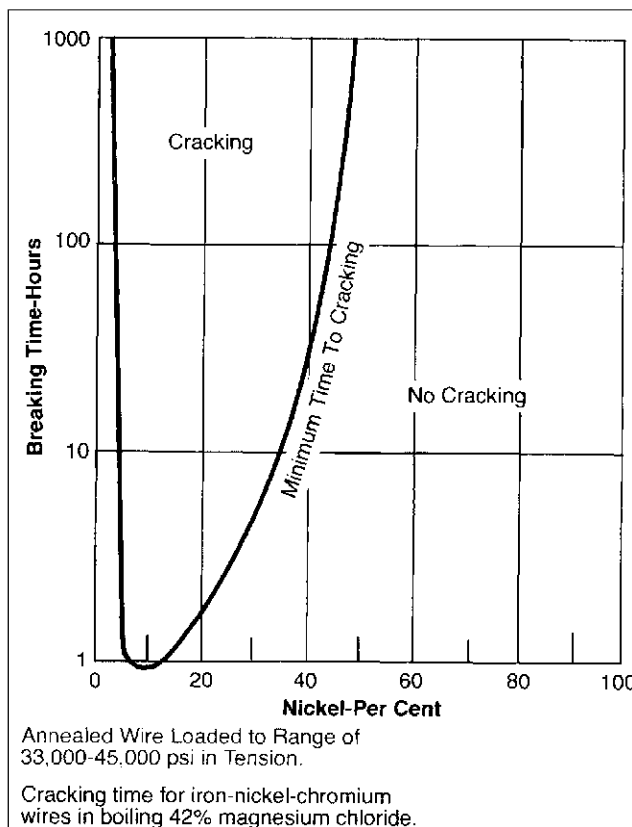

**Figure 9 Effect of Nickel on Stress-Corrosion Cracking (1)**

bolt or rivet heads where small amounts of liquid can collect and become stagnant.

The material responsible for the formation of a crevice need not be metallic. Wood, plastics, rubber, glass, concrete, asbestos, wax, and living organisms have all been reported to cause crevice corrosion. Once attack begins within the crevice, its progress is very rapid, and it is frequently more intense in chloride environments. For this reason, the stainless steels containing molybdenum are often used to minimize the problem. Notwithstanding, the best solution to crevice corrosion is a design that eliminates crevices.

**Stress-Corrosion Cracking** is caused by the combined effects of tensile stress and corrosion. Many alloy systems have been known to experience stress-corrosion cracking—brass in ammonia, carbon steel in nitrate solutions, titanium in methanol, aluminum in sea water, and gold in acetic acid. Stainless steels are susceptible to stress-corrosion cracking in chloride environments.

It is necessary for tensile stress, chlorides and elevated temperature all to be present for stress-corrosion cracking to occur. Wet-dry or heat transfer conditions, which promote the concentration of chlorides, are particularly aggressive with respect to initiating stress corrosion cracking. Such environments can prevail in evaporator service.

While the mechanism of stress-corrosion cracking is not fully understood, laboratory tests and service experience have resulted in methods to minimize the problem.

For instance, Copson<sup>1</sup> demonstrated that the nickel content of stainless steels is very important, as shown in

Figure 9. The susceptibility of austenitic stainless steels to stress-corrosion cracking is pronounced at nickel contents of 8 to 12 percent. Decreasing the nickel content, as in Type 329, or increasing it above 32 percent, as in Type 330, increases the resistance to chloride stress-corrosion cracking. Also proprietary grades 20Cb-3 and 6X and the high-nickel alloys have demonstrated resistance to stress-corrosion cracking.

An alternate approach to the problem of stress-corrosion cracking is the use of a ferritic stainless steel. The corrosion resistance of ferritic stainless steels is improved by increased chromium and molybdenum contents, while ductility, toughness, and weldability are improved by reducing carbon and nitrogen contents.

The recent commercialization of new melting and refining processes has resulted in several new ferritic stainless steels with improved characteristics, which

can be classified as follows; those with about 18 percent chromium having corrosion resistance similar to that of Type 304, and those with more than 18 percent chromium with resistance to corrosion comparable with or superior to that of Type 316 in many media.

Several proprietary ferritic stainless steels worth considering are shown in the following table. Their compositions are shown in Table 1.

Alloy	Type Number	UNS Number
18Cr + Titanium	439	S43035
18Cr - 2Mo	444	S44400
26Cr - 1 Mo (Ebrite)	-	S44627
26Cr - 1 Mo + Titanium	-	S44626
29Cr - 4Mo	-	S44700
29Cr - 4Mo - 2 Ni	-	S44800

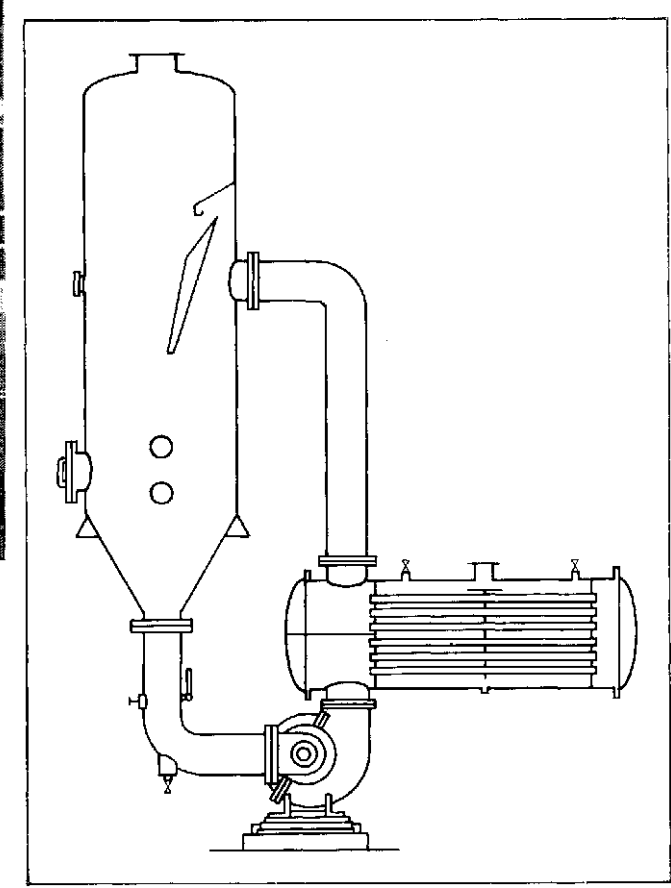
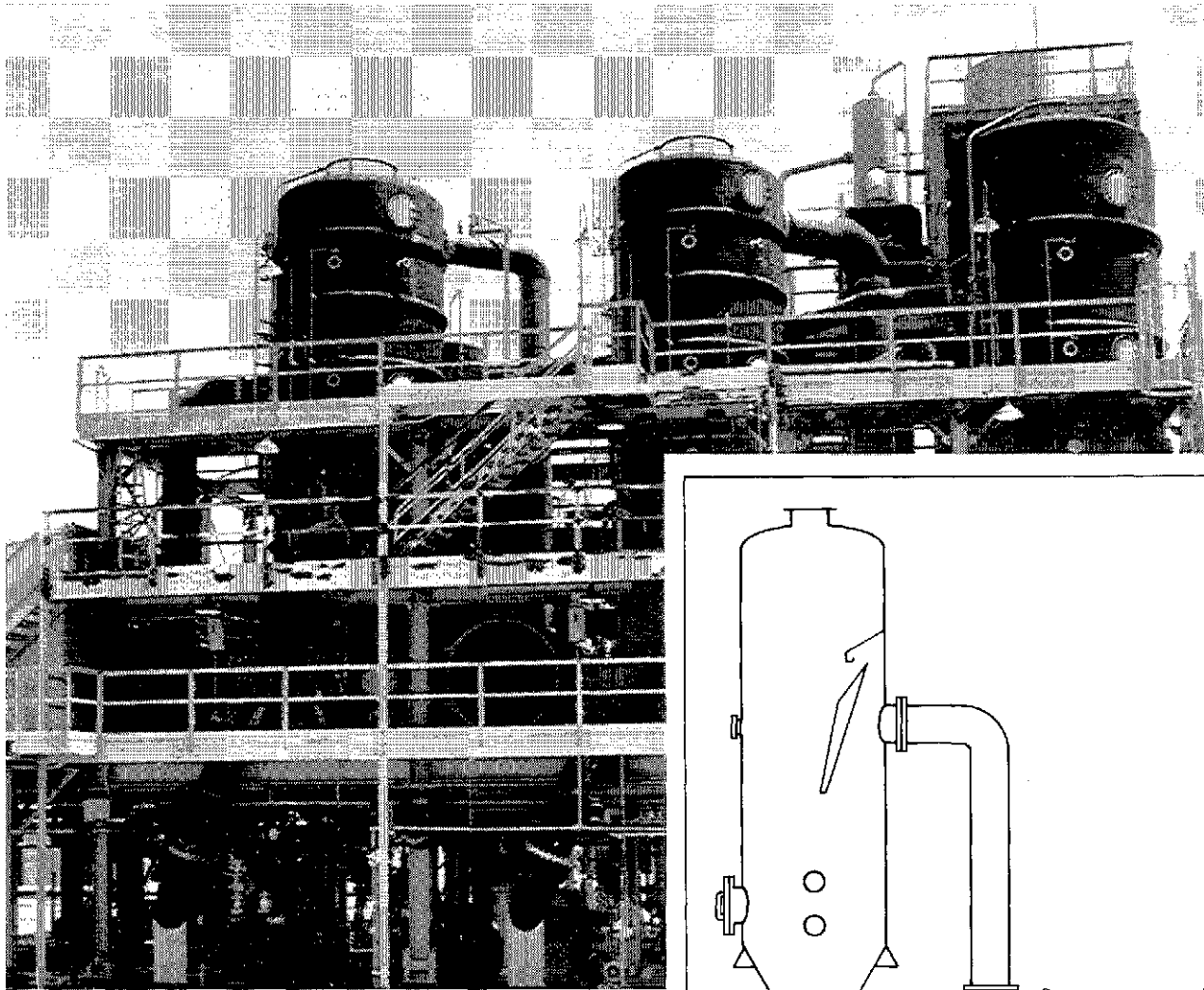

Drawing shows a Buflvak forced circulation evaporator with a horizontal steam chest, which is suggested for viscous, salting or scaling liquids. Horizontal heating surfaces are easily inspected or cleaned, and the system is readily adaptable to expansion for multiple effect. The photograph shows a triple effect forced circulation evaporator.

Photograph and drawing provided by: Blaw-Knox Food and Chemical Equipment Company, One of the White Consolidated Industries, Buffalo, New York

These ferritic stainless steels should be considered as candidate materials for high-chloride applications because they show excellent resistance to pitting and crevice corrosion and to stress-corrosion cracking. The high-chromium ferritic types have resistance to chloride environments previously available only in high-nickel and titanium alloys.

**Intergranular Corrosion.** When austenitic stainless steels are heated or cooled through the temperature range of about 800-1650°F (427-899°C), the chromium along grain boundaries tends to combine with carbon to form chromium carbides. Called carbide precipitation, or sensitization, the effect is a depletion of chromium and the lowering of corrosion resistance in areas adjacent to the grain boundary. This is a time-temperature dependent phenomenon, as shown in Figure 10.

Sensitization may result from slow cooling from annealing temperatures, stress-relieving in the sensitization range, or welding. Due to the longer time at temperature of annealing or stress-relieving, it is possible that the entire piece of material will be sensitized, whereas the shorter time at temperature characteristic of welding can result in sensitization of a band, usually 1/8 to 1/4 inch wide, adjacent to but slightly removed from the weld. This region is known as the heat-affected-zone or HAZ.

Intergranular corrosion depends upon the magnitude of the sensitization and the aggressiveness of the environment to which the sensitized material is exposed. Many environments do not cause intergranular

corrosion in sensitized austenitic stainless steels. For example, glacial acetic acid at room temperature or fresh clean water does not; strong nitric acids do.

Carbide precipitation and subsequent intergranular corrosion in austenitic stainless steels have been thoroughly investigated; the causes are understood and methods of prevention have been devised. These methods include:

1. Use of stainless steel in the annealed condition.
2. Selection of the low-carbon (0.030% maximum) stainless steels for weld fabrication. Typical low-carbon grades are Types 304L, 316L, and 317L. The less carbon available to combine with the chromium, the less likely is carbon precipitation to occur. However, the low-carbon grades may become sensitized at extremely long exposures to temperatures in the sensitization range.
3. Selection of a stabilized grade, such as Type 321 (titanium stabilized) or Type 347 (columbium stabilized), for service in the 800-1650°F (427-899°C) range. The protection obtained with these grades is based upon the greater affinity of titanium and columbium for carbon as compared to chromium.
4. Redissolving carbides by annealing parts after fabrication and then quenching, although this is not always practical.

It should be understood that the above steps are necessary only if the service environment is known to be capable of causing intergranular corrosion.

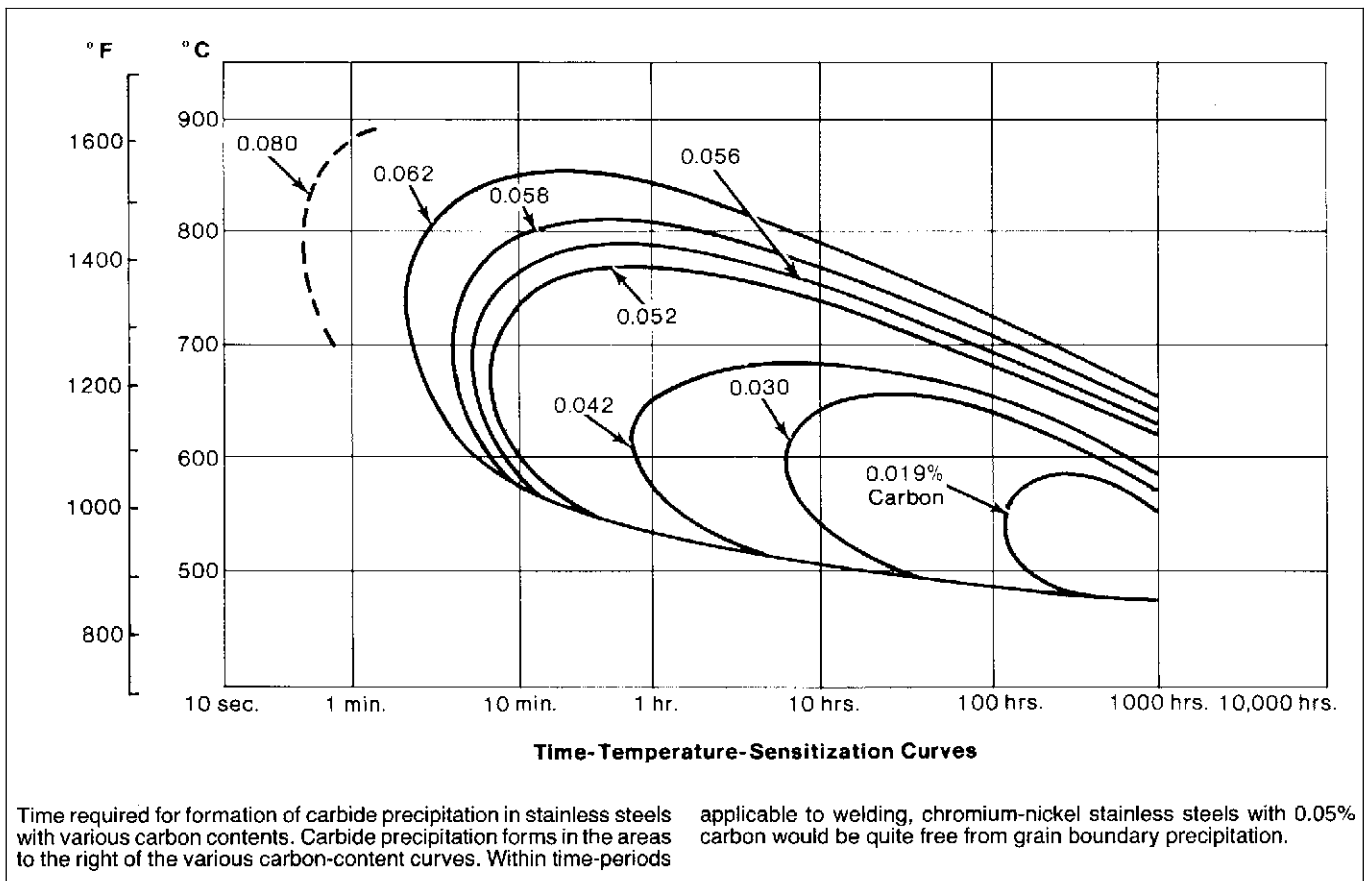

**Figure 10 Effect of Carbon on Carbide Precipitation (2)**

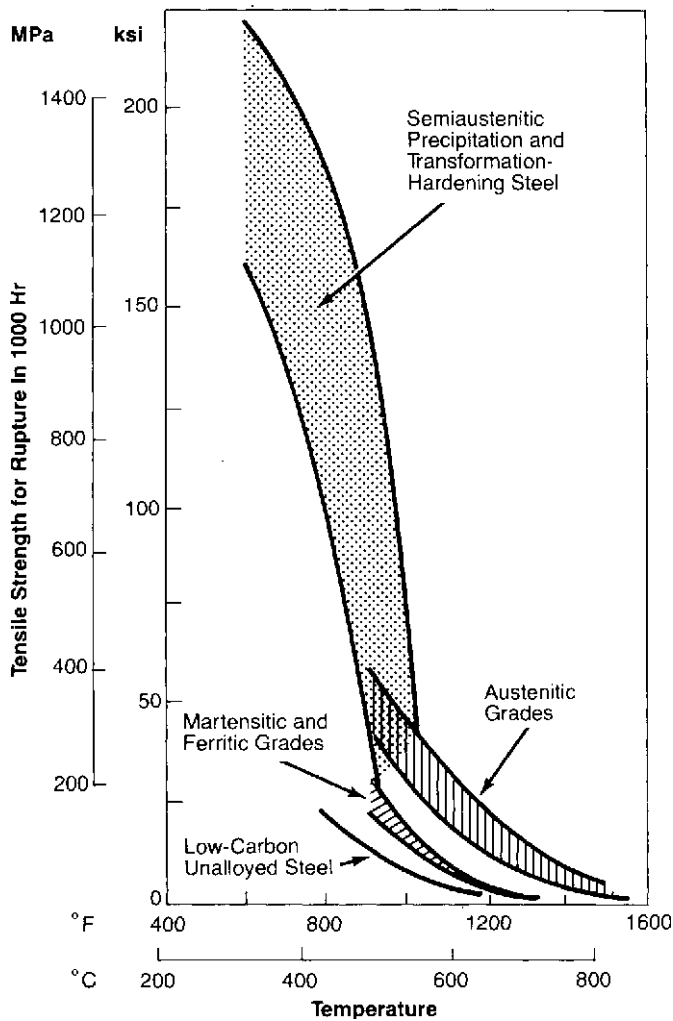

General comparison of the hot-strength characteristics of austenitic, martensitic and ferritic stainless steels with those of low-carbon unalloyed steel and semi-austenitic precipitation and transformation-hardening steels.

Figure 11 Hot-Strength Characteristics (3)

## HIGH-TEMPERATURE CORROSION RESISTANCE

Stainless steels have been widely used for elevated-temperature service, so fundamental and practical data concerning their resistance to corrosion are available.

When stainless steels are exposed at elevated temperatures, changes can occur in the nature of the surface film. For example, at mildly elevated temperatures in an oxidizing gas, a protective oxide film is formed. In an environment containing sulfur-bearing gases, the film will be in the form of sulfides, which may also be protective.

In more aggressive environments, with temperatures above 1600°F (871°C), the surface film may break down with sudden increase in scaling. Depending on alloy content and environment, the film may be self healing for a period of time followed by another breakdown. Under extreme conditions of high temperature and corrosion, the surface film may not be protective at all.

An excellent publication for further reading is the booklet "High-Temperature Characteristics of Stainless Steels." A free copy is available from The Committee of Stainless Steel Producers.

## HIGH-TEMPERATURE MECHANICAL PROPERTIES

Some stainless steels are used at temperatures up to about 2000°F (1093°C) because they have good strength at elevated temperature.

In steam power generation, for example, high allowable design stresses permit the use of thin sections and high operating temperatures. In aircraft and spacecraft design, the AISI-numbered stainless steels are used for parts in which hot strength is crucial. Stainless steels are used extensively in heat exchangers in which there is need for both corrosion resistance and hot strength, especially for pressure service. And in nuclear power, there are high-temperature applications for stainless steels in superheaters, boilers, feedwater heaters, valves, and main steam lines. At steam temperatures over 1050°F (566°C), the austenitic stainless steels are preferred.

Figure 11 gives a broad concept of the hot-strength advantages of stainless steels in comparison to low-carbon unalloyed steel.

## HEAT TRANSFER PROPERTIES

Stainless steels are used extensively for heat exchangers because their ability to remain clean enhances heat transfer efficiency. For example, Figure 12 illustrates that films and scale on exchanger surfaces impair heat transfer to a far greater extent than the metal

Steam Side Water Film	18%
Steam Side Fouling	8%
Tube Wall	2%
Water Side Fouling	33%
Water Side Film	39%

Figure 12 Factors Affecting Heat Transfer (4)

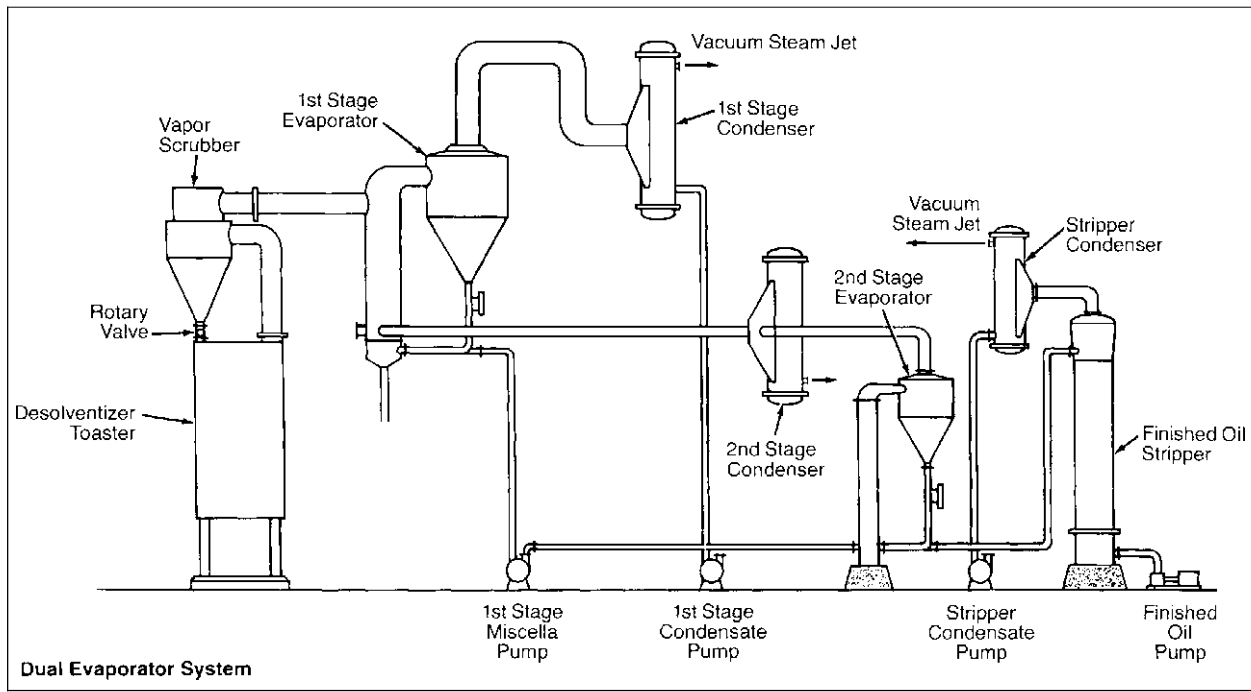

Solvent extraction, as used in connection with oil milling (soybean oil, corn oil, etc.), are equipped with single or multiple stage evaporators. For most applications, only evaporator and condenser tubes are stainless steel – typically Type 304 in ¾-inch or 1¼-inch outer diameter sizes.

Some applications, such as corn germ processing,

stainless steels are used more extensively in piping, scrubbers and evaporator and condenser shells. When desolventizing corn germ, the vapors contain ammonia sulfides.

Drawing supplied by: The French Oil Mill Machinery Co., Piqua, Ohio

wall, which accounts for only 2 percent of the total resistance to heat flow. Table 2 supports this contention by showing that thermal conductivity of a metal has only a minor effect on the "U" value, or the overall heat transfer coefficient.

The degree to which other factors affect heat transfer

are dependent on the type of fluid involved, its velocity, and the nature of scale or fouling buildup on the surface. Since corrosion and scale accumulation are minimum with stainless steels, there would be less difference in service performance among various metals than would be indicated by thermal conductivity data.

**TABLE 2**  
**EFFECT OF METAL CONDUCTIVITY ON "U" VALUES (5)**

Application	Material	Film Coefficients Btu/hr/ft <sup>2</sup> /°F (W/m <sup>2</sup> ·K)		Thermal Conductivity of Metal Btu/hr/ft <sup>2</sup> /°F/in. (W/m·K)	"U" Value Btu/hr/ft <sup>2</sup> /°F (W/m <sup>2</sup> ·K)
		h <sub>o</sub>	h <sub>i</sub>		
Heating water with saturated steam	Copper	300 (1704)	1000 (5678)	2680 (387)	229 (1300)
	Aluminum	300 (1704)	1000 (5678)	1570 (226)	228 (1295)
	Carbon Steel	300 (1704)	1000 (5678)	460 (66)	223 (1266)
	Stainless Steel	300 (1704)	1000 (5678)	105 (15)	198 (1124)
Heating air with saturated steam	Copper	5 (28)	1000 (5678)	2680 (387)	4.98 (28)
	Aluminum	5 (28)	1000 (5678)	570 (226)	4.97 (28)
	Carbon Steel	5 (28)	1000 (5678)	460 (66)	4.97 (28)
	Stainless Steel	5 (28)	1000 (5678)	105 (15)	4.96 (28)

where h<sub>o</sub> = outside fluid film heat-transfer coefficient  
h<sub>i</sub> = inside fluid film heat-transfer coefficient  
Stainless steel is 300 Series Type

$$"U" = \frac{1}{\frac{1}{h_o} + \frac{\text{thickness of metal wall}}{\text{thermal conductivity}} + \frac{1}{h_i}}$$



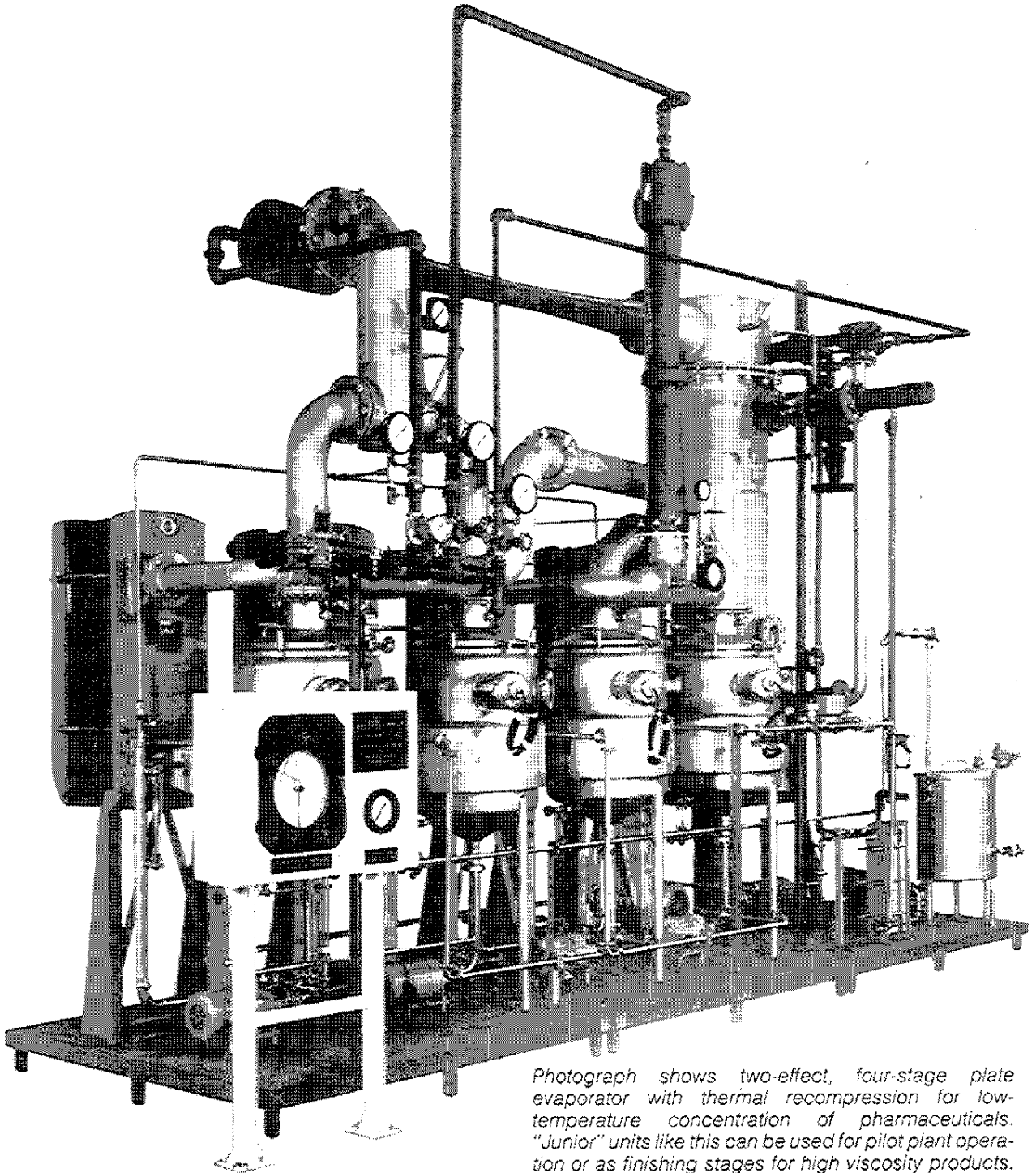

*Photograph shows two-effect, four-stage plate evaporator with thermal recompression for low-temperature concentration of pharmaceuticals. "Junior" units like this can be used for pilot plant operation or as finishing stages for high viscosity products. For whatever use, stainless steel construction provides easy-to-maintain, sanitary, contamination-free operation.*

*Photograph provided by: APV Company, Inc., Tonawanda, New York*

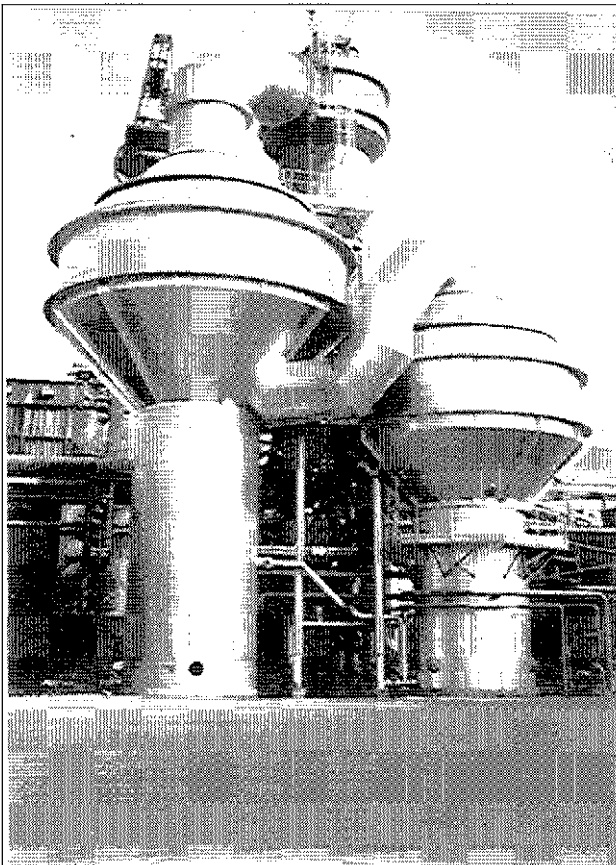

1▲

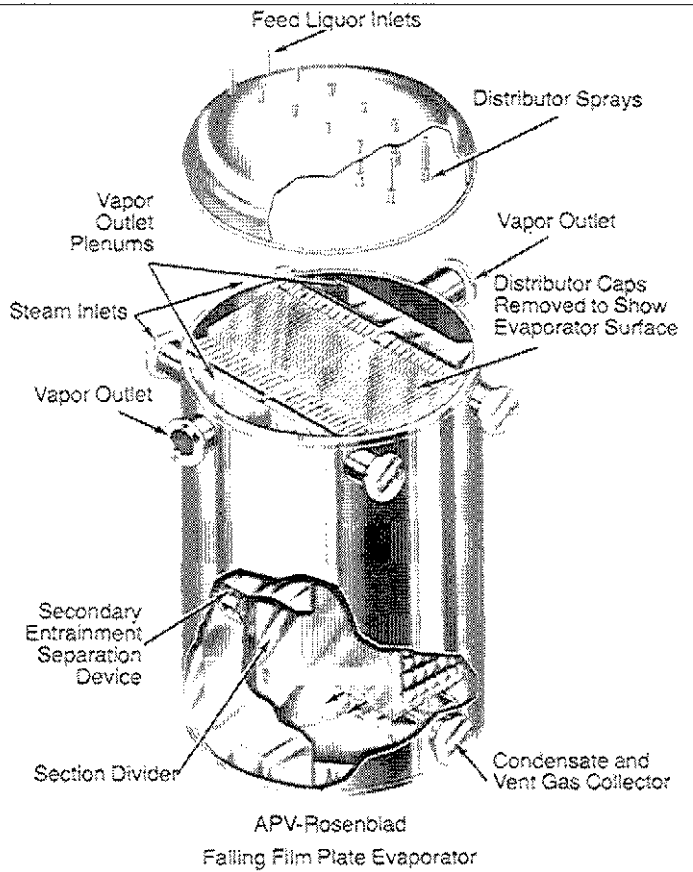

2▼

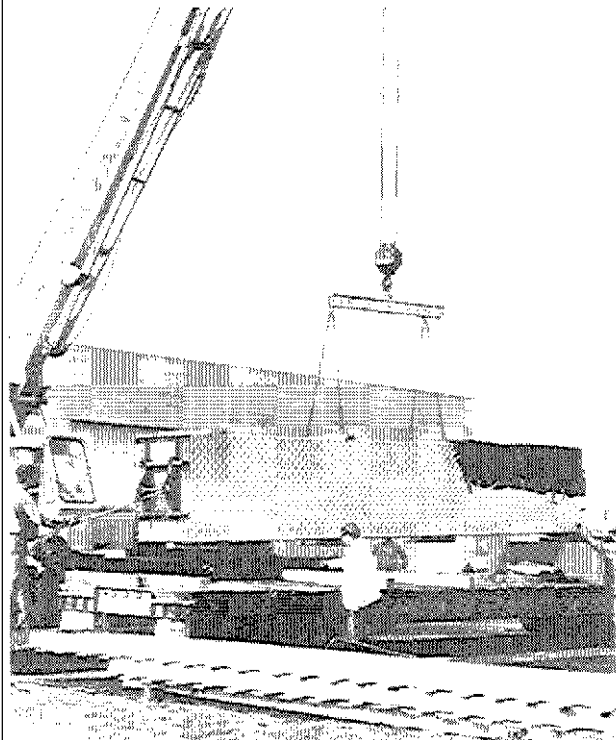

3▼

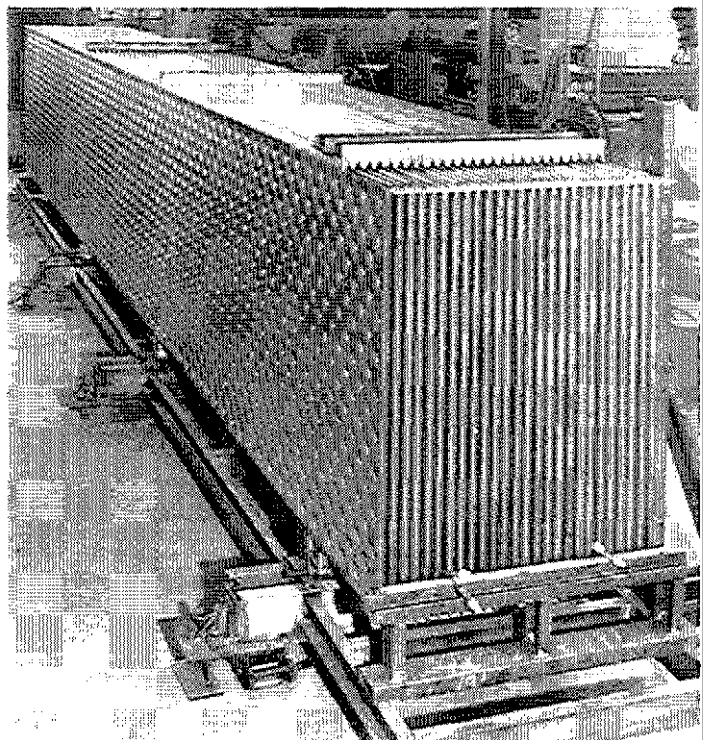

Photograph 1 shows a double-effect blow heat evaporator with surface condenser, containing approximately 120,000 square feet of Type 304L stainless steel plate-type heating surface. Photographs 2 and 3 show shop fabrication of the plate assemblies, and the drawing shows typical arrangement in a falling film plate evaporator. Plate elements are normally arranged

in parallel to provide maximum heating surface within minimum vessel diameter. However, plate elements can be arranged in a fan-shaped configuration, which is particularly suitable for high solids evaporation.

Photographs provided by: Rosenblad Corporation, Princeton, New Jersey

# FABRICATION

Stainless steels are generally selected, first on the basis of corrosion resistance and, second, on the basis of strength or other mechanical properties. A third-level consideration is fabrication. While the three general-purpose stainless types predominate, namely Types 304, 430, and 410, there are variations of these types that are better suited to certain manufacturing operations. Service requirements may preclude the use of these variations, however, so it is well to know that all stainless steels can be readily fabricated by conventional manufacturing methods.

# Hot Forming

Stainless steels are readily formed by hot operations such as rolling, extrusion, and forging—the latter method results in finished or semifinished parts.

Hot rolling is generally a steel mill operation for producing standard mill forms and special shapes. Extrusion is usually associated with softer, non-ferrous metals. In extrusion, a shaped piece is made by forcing a bar or billet through a die, the exiting cross-section conforming to the die opening. Several companies produce hot extrusions in stainless steel.

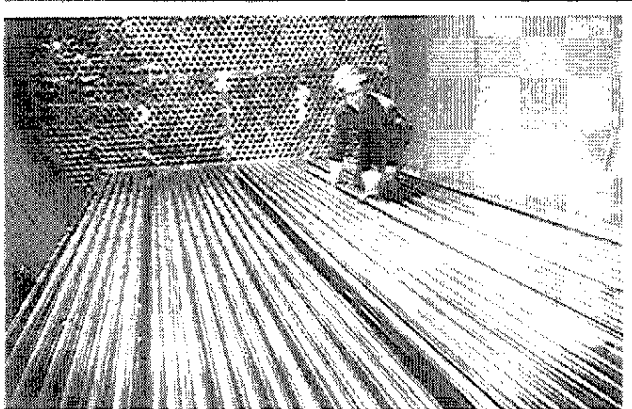
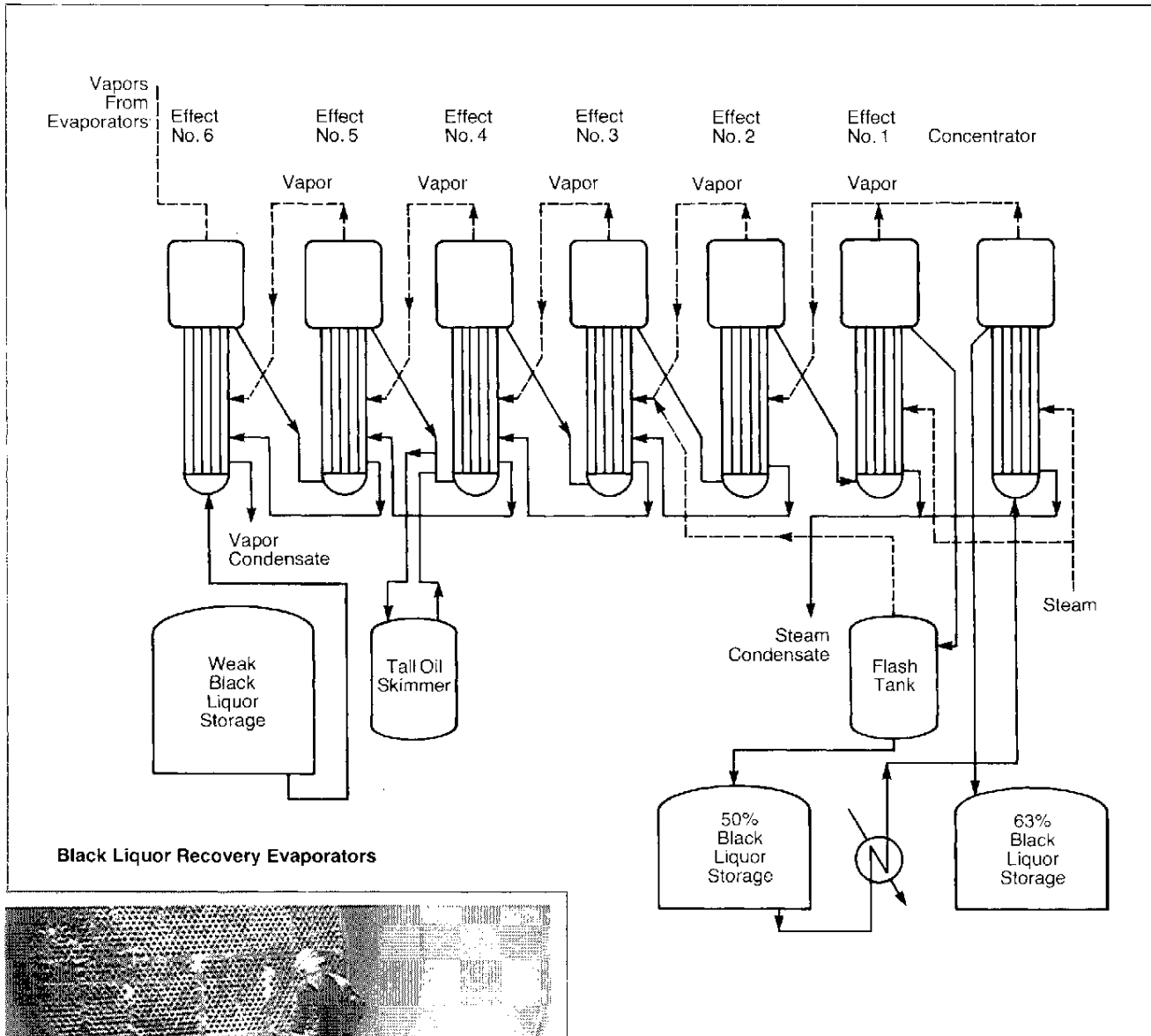

Drawing shows typical flow diagram six-effect evaporator used for concentrating black liquor in a pulp and paper mill. Photograph shows workers installing stainless steel tubes in a Kraft mill evaporator. In most mills, all effects are tubed with stainless steel, generally Type 304. Also in many mills evaporator vapor bodies, tube sheets, and internal liquor boxes utilize stainless steels for long service life.

## Cold Forming

The mechanical properties of stainless steels serve as an indication of their relative formability at ambient or room temperature. Annealed austenitic grades are typified as having low yield strengths, high tensile strengths, and high elongations. Some of these alloys work harden to a high degree during cold work, which further increases their strength properties. The ferritic alloys have much lower ductility than the austenitic types and are closer to carbon steel with respect to mechanical properties; and they do not work harden significantly during cold forming. Because of their excellent mechanical properties, stainless steels have excellent cold-forming characteristics.

## Machining

The machining characteristics of stainless steels are substantially different from those of carbon or alloy steels and other metals. In varying degree, most stainless steels without composition modification are tough, rather gummy, and they tend to seize and gall.

While the 400 Series stainless steels are the easiest to machine, a stringy chip produced during the machining can slow productivity. The 200 and 300 Series, on the other hand, have the most difficult machining characteristics, primarily because of their propensity to

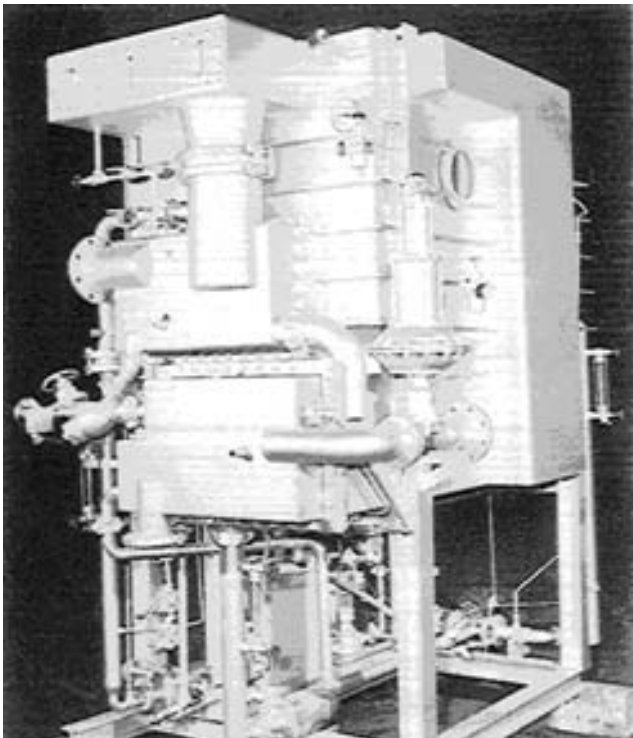

*Evaporation technology has long been applied to the distillation of seawater to produce fresh water. Stainless steels, especially the "seawater grades," are being used successfully in seawater environments. The photograph shows a flash distillation unit that is used aboard the Mississippi Queen Riverboat.*

*Photograph provided by: Riley-Beard, Shreveport, Louisiana*

work harden at a very rapid rate.

An experienced machine shop production engineer can work around these conditions and achieve good productivity with any of the stainless steels. Here are three suggestions: 1) specify a free-machining stainless steel, 2) suggest the use of a special analysis stainless steel that is "more suited for machining," or 3) specify stainless steel bar for machining that is in a slightly hardened condition.

A publication available from the Committee of Stainless Steel Producers discusses "Free-Machining Stainless Steels."

## Joining

**Welding.** Nearly all of the stainless steels can be welded by most methods employed by industry today. Because of differences between these alloys and carbon or low-alloy steels, however, there are variations in welding techniques.

First, it is important that procedures be followed to preserve corrosion resistance in the weld and in the area immediately adjacent to the weld, referred to as the heat-affected-zone (HAZ). Second, it is desirable to maintain optimum mechanical properties in the joint, and third, certain steps are necessary to minimize problems of heat distortion.

The principal difference between stainless and other steel types is alloy content, which provides corrosion resistance. In welding, it is necessary to select a weld rod that provides weld filler metal having corrosion resistance properties as nearly identical to the base metal as possible—or better. This is not always as obvious as some might expect. For instance, a Type 308 weld rod is specified for welding Type 304, and a 300 Series rod is often used for joining 400 Series types. The best suggestion is to follow American Welding Society (AWS) practices for weld rod selection and weld procedures, or to consult weld rod manufacturers. The latter have up-to-date tables for rod selection.

Another principal difference between stainless and carbon or low-alloy steels is thermal conductivity, with stainless about half that of other steels. Hence, heat is not dissipated as rapidly.

There are four methods to accommodate this situation: lower weld current settings, skip-weld techniques to minimize heat concentration, use of back-up chill bars or other cooling techniques to dissipate heat, and proper joint design. The first three methods fall in the realm of welding shop procedures that are often adequately covered by AWS recommended practices and welding shop standard practices. It is always good policy, however, to double check to see that the welding shop follows proper procedures.

Cleaning of the edges to be welded is important. Contamination from grease and oil can lead to carburization in the weld area with subsequent reduction of corrosion resistance. Post weld clean-up is also important and should not be done with carbon steel files and brushes. Carbon steel cleaning tools, as well as grinding wheels that are used on carbon steel, can leave fine particles imbedded in the stainless steel surface that will later rust and stain if not removed by chemical cleaning.

The booklet, "Welding of Stainless Steels and Other Joining Methods" is available from the Committee of Stainless Steel Producers."

## Tube-to-Tube Sheet Joining

In shell and tube heat exchangers there are two basic methods for joining tubes to tube sheets; mechanical and welding. In either case, the joint is critical and must provide positive assurance against leakage. This is especially important in stainless steel heat exchangers, because of the nature of the environments that are usually involved, intermixing of the media can be seriously detrimental either to the equipment or to the process.

In many noncritical applications, a mechanically expanded tube-to-tube sheet joint provides a satisfactory barrier for many years of service. Tubes are commonly roller expanded into double ring grooved tube sheet holes, with tube metal displacement into the grooves providing added strength to resist axial loading.

For critical applications, however, seal-welded or strength-welded joints can be provided, as illustrated by Figures 13 and 14. Welding is sometimes followed by expansion of the tubes into grooved tube sheets, such that axial loads are carried by the expanded zone rather than the weld.

Tube end welds involving stainless steels are made by gas tungsten arc welding (GTAW) methods. Seal

welds generally require a single weld pass, with or without filler metal. Strength-welded joints generally necessitate multiple weld passes.

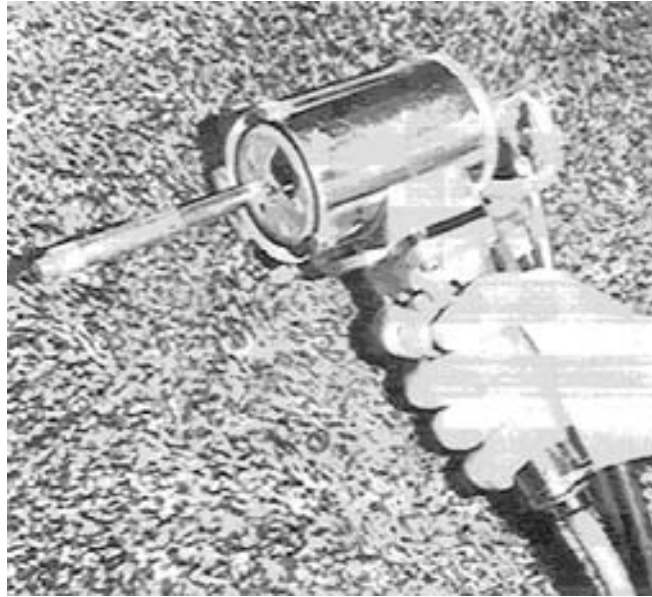

Photograph shows small hand-held welding gun that, when positioned over the tube end and triggered, automatically purges the welding area with inert gas, supplies a preset amperage, and rotates the tungsten electrode around the tube circumference.

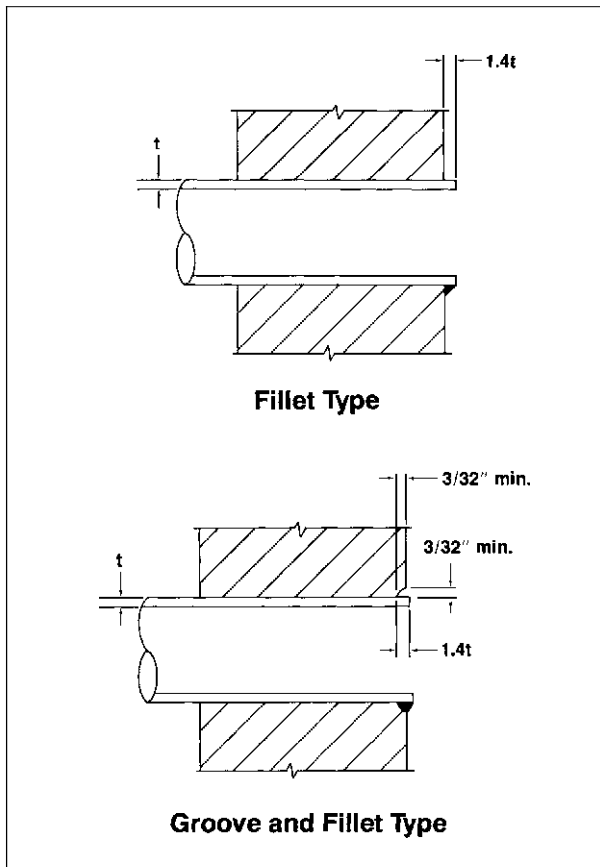

Figure 13 Typical Seal Welded Tube Ends.

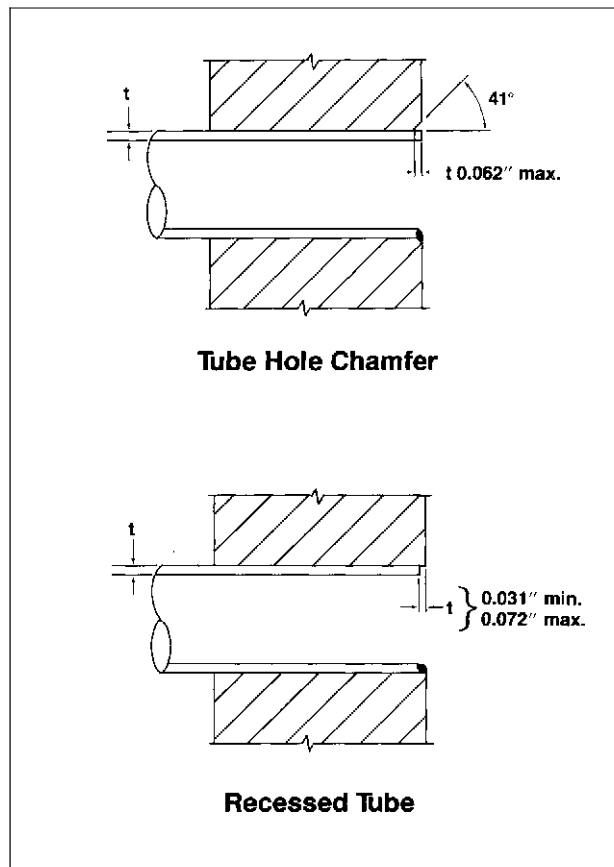

Figure 14 Strength Welded Tube Ends.

# REFERENCES

1. H.R. Copson, "Effect of Composition on Stress-Corrosion Cracking of Some Alloys Containing Nickel," Physical Metallurgy of Stress-Corrosion Fracture, Interscience Publishers, New York, 1959.
2. Svetsaren English Edition 1-2, 1969.
3. General Stainless Steel Industry Data.
4. E.L. Lustenader and F.W. Staub, "Development Contribution to Compact Condenser Design," The International Nickel Company Power Conference, May 1964 (Unpublished).
5. Tranter Mfg., Inc.