

Standard Cabinet Specs

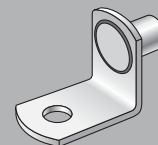
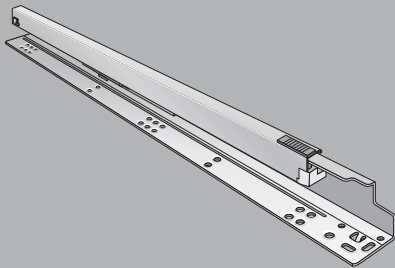
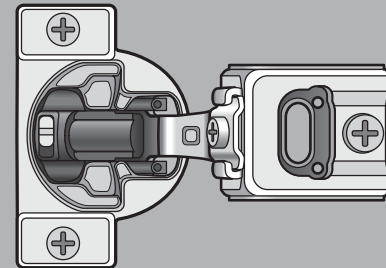
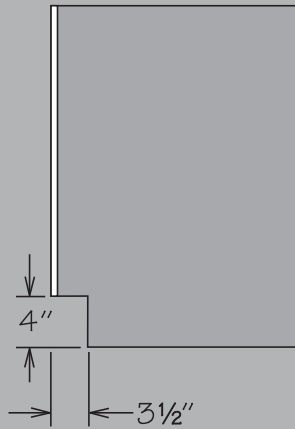
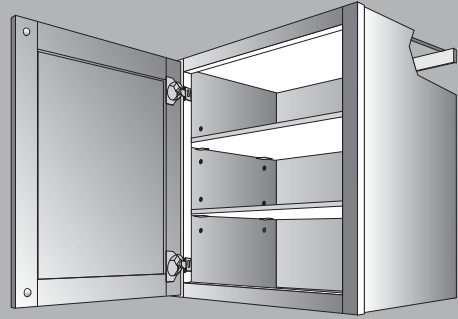
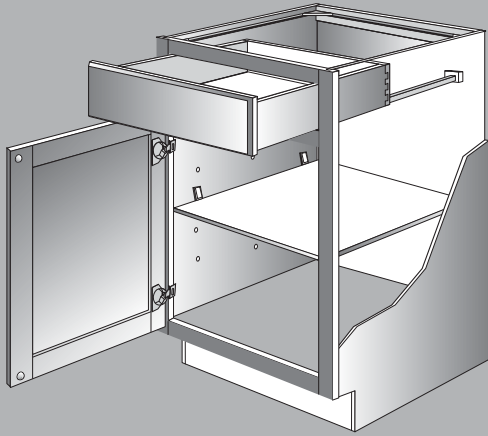

KCMA Certified

All cabinetry manufactured by Shenandoah is certified by the Kitchen Cabinet Manufacturers Association (KCMA).

KCMA sets the American National Standards Institute/KCMA 161.1- 2000 uniform performance and construction standards for kitchen and vanity cabinets. The program is referenced by U.S. Government agencies; architects; builders; remodelers; and other specifiers.

Cabinets that bear the KCMA seal of certification are recognized as a quality product with the ability to perform after a rigorous battery of tests, simulating years of typical household use. Tests are performed by approved third-party independent laboratories.

Shenandoah is proud to display the KCMA seal of certification for cabinet construction.



ANSI/KCMA A161.1

Environmentally Responsible Stewardship

As a leading U.S. manufacturer of fine cabinetry, American Woodmark Corporation is committed to conducting business in a manner that both protects the environment and safeguards public health and safety. To achieve this end, the company proactively identifies potential environmental risks and monitors compliance with appropriate federal, state, local and internal standards.

The company has received certification by the Kitchen Cabinet Manufacturers Association (KCMA) Environmental Stewardship Program on all products. The certification was awarded based on compliance across a broad range of activity including air quality, product resource management, process resource management, environmental stewardship and community relations.

The company works with all suppliers to encourage sustainable forestry practices. Wood doors, drawer fronts and cabinet front frames are made from solid hardwoods. Particle board and plywood are purchased from suppliers that meet either the Composite Panel Association requirements for Environmentally Preferred Products or the Composite Panel Associations Eco-Certified Composite Standards.

The company uses leading edge technologies to limit both hazardous and non-hazardous emissions, byproducts and waste. Ongoing, formal programs identify opportunities for recycling and reusing materials. When waste ultimately requires disposal, steps are taken to minimize the environmental impact.

The American Woodmark Foundation supports local programs serving the community, including activities focused on maintaining the quality of life.

Our company is dedicated to doing our part in the preservation and sustainability of the environment.



KITCHEN CABINET MANUFACTURERS ASSOCIATION
ENVIRONMENTAL STEWARDSHIP PROGRAM (ESP)
ALL PRODUCTS IMPACT THE ENVIRONMENT
FOR ESP PROGRAM CRITERIA, VISIT KCMA.ORG

Cabinet Front Face Frames

Cabinet front face frames are made from $\frac{3}{4}$ " x $1\frac{5}{8}$ " solid hardwood. They are kiln-dried to prevent warping and finished using our BeautyGuard finishing system. Face frame joints are precision fixtured, pressure fitted and mechanically fastened.

Cabinet Side Panels

Cabinet side panels are $\frac{1}{2}$ " thick engineered wood. The exterior sides match cabinet finish and interior sides are finished with a natural woodgrain look using our TuffTech® finishing system. They are captured into a grooved front face frame and secured using high-strength fasteners and glue.

Cabinet Tops, Bottoms and Floors

Tops, bottoms and floors are $\frac{1}{2}$ " thick engineered wood. The exteriors and interiors are finished with a natural woodgrain look using our TuffTech® finishing system. They are fitted and glued into the cabinet front face frame grooves, then captured in the grooves of the cabinet side panels.

Cabinet Back

The cabinet back is made from $\frac{1}{8}$ " thick hardboard substrate. The inside cabinet surface is finished with a natural woodgrain look using our TuffTech finishing system.

Hanging Rails

The base and vanity top hanging rail is $\frac{3}{4}$ " thick solid wood, mortise and tenon joined and glued to the cabinet side panels. The wall cabinet hanging rails are $\frac{1}{2}$ " thick engineered wood, glued and pinned into the cabinet back, cabinet side panels and top/bottom.

Cabinet Shelves

Cabinet shelves are $\frac{3}{4}$ " thick engineered wood. The shelves are finished with a natural woodgrain look using our TuffTech finishing system. Shelves are banded on one side with edge banding. All shelves are adjustable and meet KCMA load standards of 15 pounds per square foot.

Drawer Systems

Cabinets utilize natural finish dovetail hardwood drawers with plywood bottoms and Full-Access Hidden Glides® or Full-Access CushionClose Glides. All drawers meet KCMA load standards of 15 pounds per square foot.

Drawer Systems-Deep Roll Out Trays

Deep Roll Out Trays utilize natural finish dovetail hardwood drawers. Deep Roll Out Trays feature side-mounted $\frac{3}{4}$ " access drawer glides or Full-Access CushionClose glides. All Deep Roll Out Trays meet KCMA load standards of 15 pounds per square foot.

Corner Blocks

Corner blocks are attached to help ensure cabinet squareness and allow for proper countertop installation.

Hinges

Fully concealed, self-closing Hidden Hinges® are standard on all door styles.

Door Height	Number of Hinges
12" - 36"	2
39" - 50"	3

Inset Toe Kick

Inset toe kicks are constructed of $\frac{1}{2}$ " thick **unfinished** engineered wood and are recessed $3\frac{1}{2}$ ". Standard toe kick dimensions are 4" high and recessed $3\frac{1}{2}$ ". Universal Design toe kick dimensions are 8" high and recessed $6\frac{1}{2}$ ".

BTK8 or BTK UD (matching toe kick) required for installation.

CONTINUOUS IMPROVEMENT

In keeping with our policy of continuous product refinement, Shenandoah Cabinetry reserves the right to change specifications in design and materials as conditions require.

Finishing Systems

The finishing systems used on our products are designed to ensure the beauty and durability of our cabinetry. State-of-the-art equipment allows precise sanding, filling and finish coverage of each of our products.

BeautyGuard[®] Finishing System

BeautyGuard is an extremely sophisticated and environmentally responsible coating that offers durability, ease of cleaning and water resistance. We use a combination of mechanical systems to bring out the richness, luster and natural grain definition of the wood, as well as computerized automation to ensure color consistency and surface smoothness. Our BeautyGuard Finishing System is a rigorous multi-step process that includes sanding, brushing, cleaning, stain application, computerized oven drying and a catalyzed topcoat to protect and beautify cabinets for years to come.

TuffTech Finishing System

Our TuffTech finishing system uses high quality materials to finish our cabinet side panels, shelves, tops, bottoms and floors. These materials ensure our cabinets are durable, easy to clean, and resistant to stain and discoloration.

Environmentally Responsible Finishing

Our panel finishing system uses only water-based paints and fillers, yielding neither hazardous waste nor water contamination. Our acrylic and urethane materials are 100% solids, dried using high-intensity lights, yielding no atmospheric emissions. Our products are extremely resistant to stains and surface damage that can be caused by common household chemicals. Our products exceed KCMA and ANSI standards for resistance to stains like coffee, grape juice and moisture.

Cabinet Care

Remove dust from cabinets frequently with a soft lint-free cloth. The cloth may be slightly dampened with water or a spray type dust remover. Wood and laminate cabinet surfaces may be polished once every few months with a high-quality, non-oil-based furniture polish. Do not use a paste wax type material. Wax buildup is difficult to remove and will leave a residue that attracts dust and moisture. Polishes containing silicon should not be used. Clean spills immediately. Use a clean cloth and mild soap if necessary. Wipe dry with a clean soft cloth. Do not use detergents, citrus cleaners, ammonia-based cleaners, chlorine-based cleaners, steel wool, soap pads or abrasive cleaners on cabinets.

Extra care should be taken that cabinet finishes are not exposed to heat in excess of 200° Fahrenheit (174° for Duraform thermofoil door styles). Do not place or mount small appliances beneath wall cabinets. These appliances (such as coffee makers and toasters) can produce excessive heat, which can damage the finish of cabinets. Do not expose Duraform thermofoil doors or drawer fronts to heat created from self-cleaning ovens or ranges. The HSK (Heat Shield Kit) should be used when Duraform thermofoil cabinets are installed or mounted directly next to ovens or ranges.

Allow Cabinets To Age Beautifully

Our cabinets showcase the careful selection of natural and engineered materials to achieve the best possible look. While every effort is made to match wood grain as closely as possible, no two pieces of wood are exactly alike, even from the same tree. These differences in natural color and grain mean that each piece will respond differently to the finishing materials used. For example, close-grained woods absorb less and will vary in color from more open-grained pieces from the very same tree. It's these variations that contribute to the beauty and distinction of quality wood products. However, exposure to sunlight, smoke and chemicals may cause some materials to fade or vary from their original color over time.

This is why cabinets, doors, drawer fronts and accessories added at a later date may not exactly match cabinets installed now. For the same reasons, door samples or displays may not represent the exact color of cabinets received at the time of shipment. Consumers should also read all cleaning agent instructions carefully before application.

Due to changes that occur from natural and environmental factors a cabinet is exposed to over its lifetime, we cannot be responsible for variations that occur in the finish of natural and engineered materials as they age.

Door Species & Characteristics

Shenandoah Cabinetry incorporates solid hardwoods and hardwood veneers. These are natural materials with inherent variations. As such, our quality standards establish tolerance ranges for matching the hardwood pieces. Consumers should review actual samples of hardwoods in our buying centers and cabinet displays to help establish realistic expectations of variations involving wood grain, color tones, presence of knots and so forth.

These variations are at the heart of the unique natural beauty of finished hardwood. In addition, exposure of wood products to sunlight, some chemical agents and smoke can cause wood colors to change over time.

Cherry

Cherry is a close-grained, multicolored hardwood with occasional pin knots and fine grain variations appearing as curls and waves. Natural features of Cherry include:

- Small sap pockets, pin knots and streaks
- Color ranges from pale yellow sapwood to deep reddish-brown heartwood, with occasional shades of white, green, pink or even gray
- Staining reveals subtle variations and colors that typically darken over time
- Variations within a single door

Maple

Maple is an exceptionally hard, finely grained wood species with a fine, even texture. Darker stains will moderate the color variance; lighter stains mellow with golden hues over time. Natural features of Maple include:

- White to light blonde tones to dark reddish-brown tones
- Small mineral streaks of light blond or reddish brown that darken with stain
- Wavy, curly bird's-eye or burl graining as well as worm tracking across the grain that will darken when stained
- Variations within a single door

Painted

Painted finishes combine hardwoods and engineered materials including solid wood, medium density fiberboard (MDF), high density fiberboard (HDF) and similar materials to achieve a product with superior stability, consistency, coverage and durability. Painted door features include:

- Joint lines caused by the natural expansion and contraction of wood
- A natural aging process that may change the tone of paint colors over time

Duraform

Duraform uses highly-technological manufacturing processes to bond foils, vinyl films and coatings to medium density fiberboard (MDF), high density fiberboard (HDF) and similar materials to achieve a product with exceptional stability, consistency and durability.

- The finish, color and texture are consistent throughout the surface
- The surface is highly durable and easy to clean
- Materials are resistant to humidity and fading
- Refer to page 33 for standard cabinet box construction

Shenandoah Cabinetry wall cabinets are constructed using high-quality materials and hardware.

The drawing below illustrates and identifies the parts of a standard Shenandoah Cabinetry wall cabinet.

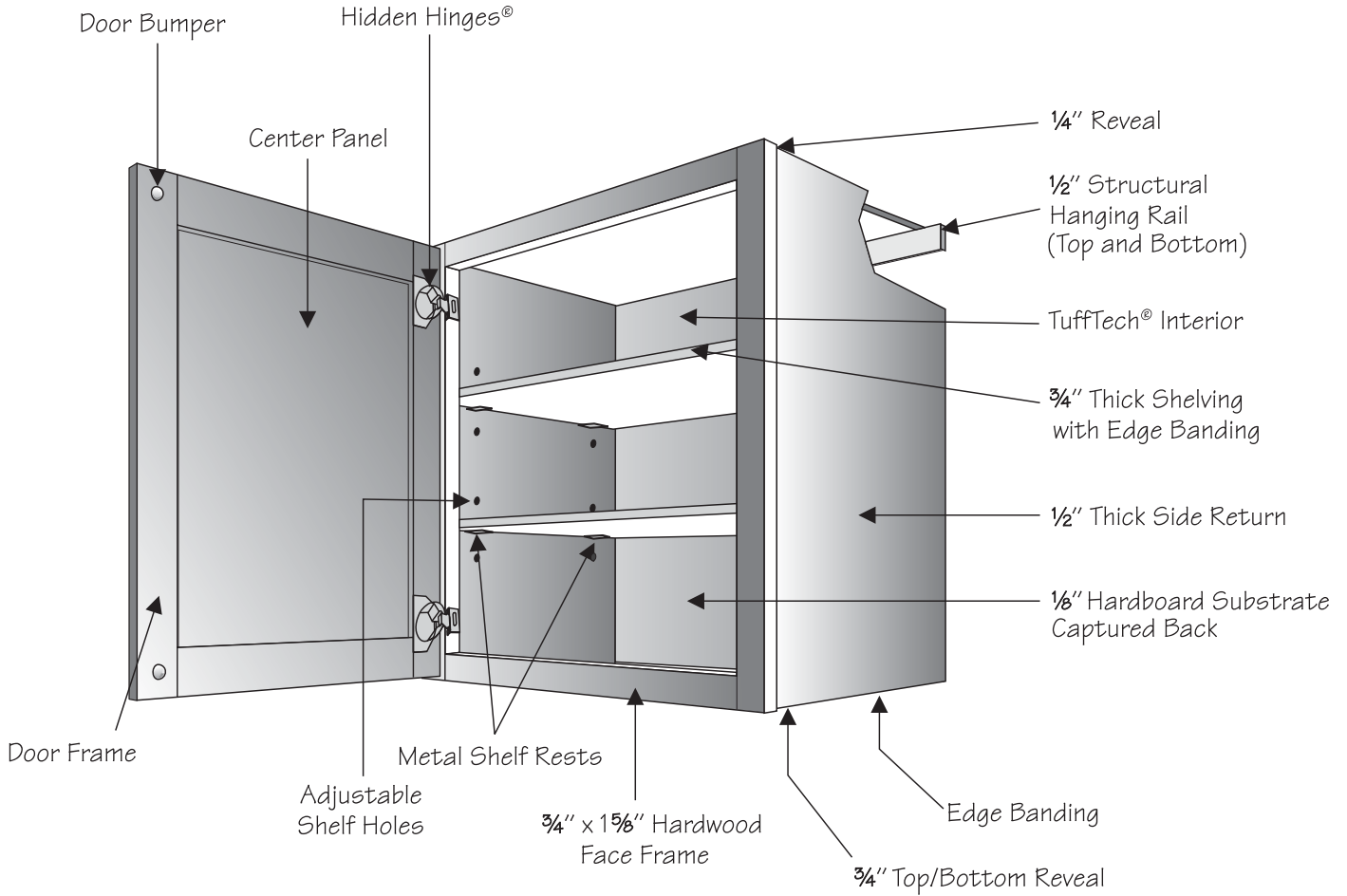

Shenandoah Cabinetry base cabinets are constructed using high-quality materials and hardware.

The drawing below illustrates and identifies the parts of a standard Shenandoah Cabinetry base cabinet.

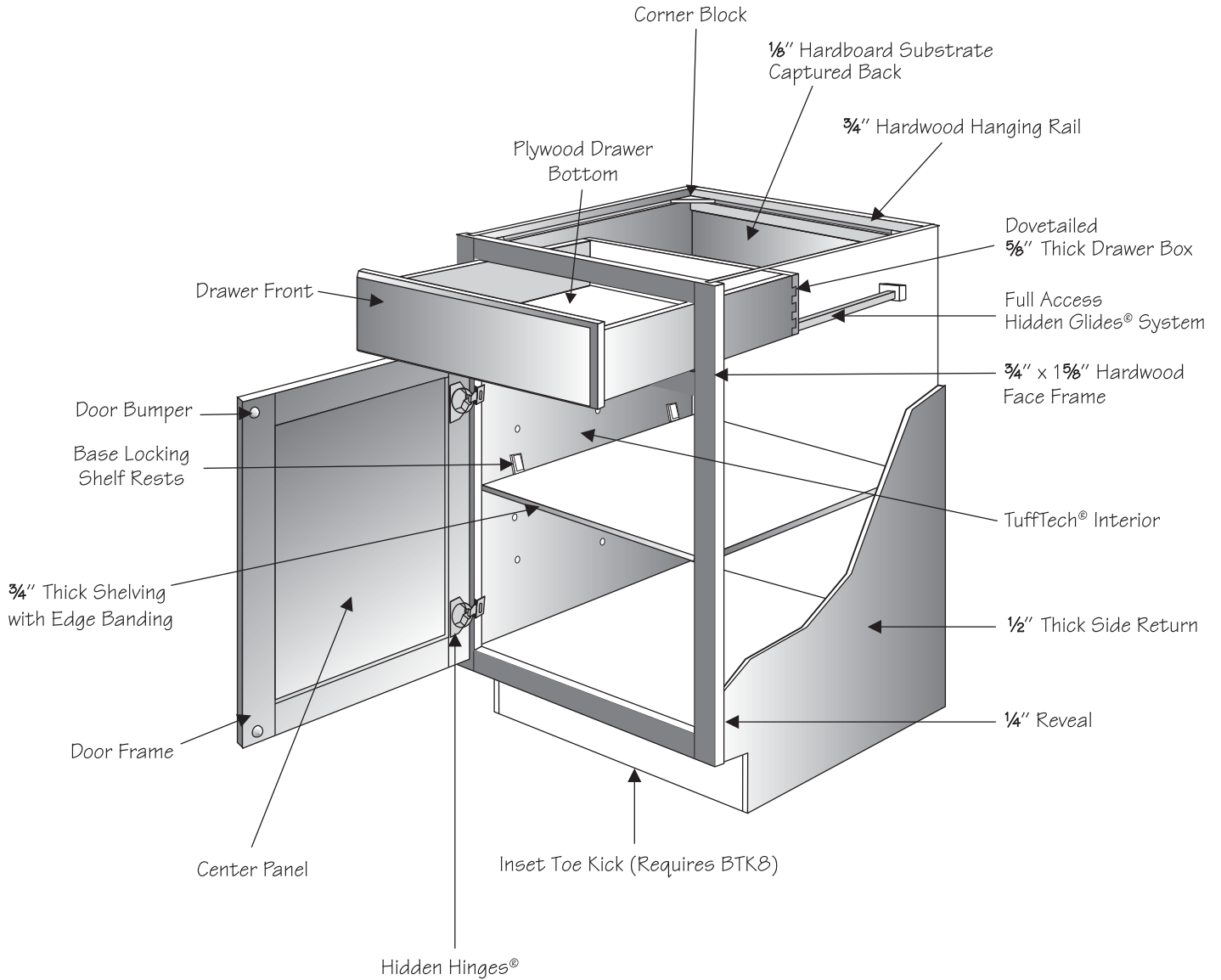

NOTE: Base single door cabinets are hinged left and can be reversed in the field.

6-Way Adjustable Full Overlay (FOL) Door Hinge

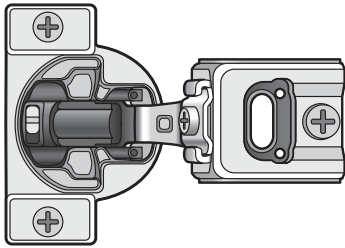

All steel construction with nickel-plated finish, 1 1/2" Full Overlay hinge with self-closing feature that allows door to close unassisted when approximately 20-30 degrees open. Hinge allows less than 3/16" frame-to-door gap. Six-way adjustability allows superior in/out adjustment of 1/8", up/down adjustment of 1/4" and side-to-side adjustment of 1/8". Exceeds industry standard for durability. Standard feature on all Full Overlay (FOL) door styles. Hinges permit doors to open to approximately 105 degrees.

6-Way Adjustable Standard Overlay (SOL) Door Hinge

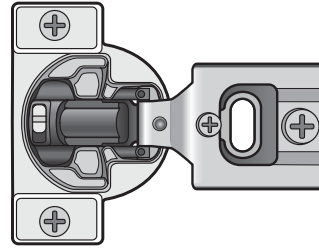

All steel construction with nickel-plated finish, 3/8" Standard Overlay hinge with self-closing feature that allows door to close unassisted when approximately 20-30 degrees open. Hinge allows less than 3/16" frame-to-door gap. Six-way adjustability allows superior in/out adjustment of 1/8", up/down adjustment of 1/4" and side-to-side adjustment of 1/8". Exceeds industry standard for durability. Standard feature on all Standard Overlay (SOL) door styles. Hinges permit doors to open to approximately 105 degrees.

Full-Access Hidden Glides System

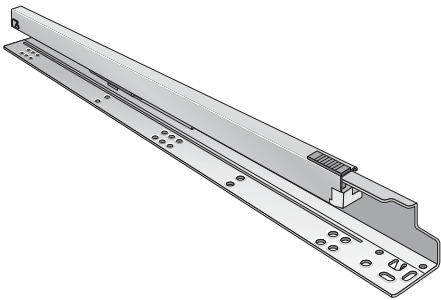

The Full-Access Hidden Glide System features dual-telescoping glide members that are supported by precision roller-carriage bearings providing smooth, stable and quiet operation. This glide system opens fully to provide complete access to drawer contents and features an integrated self-closing mechanism.

Side-Mounted Roll-Out Tray Glides

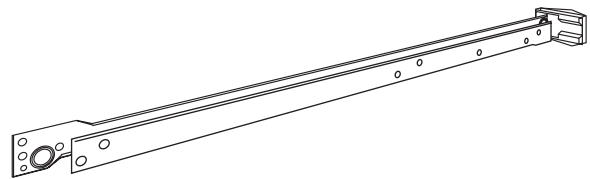

This 3/4 access glide system features twin self-aligning side-mounted drawer glides. They are constructed of epoxy-coated steel for quiet opening and closing. Rollers are made of Delrin for smooth operation.

Metal Shelf Rest

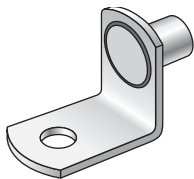

1/4" steel, nickel plated. Standard feature on all wall cabinets, bookshelves, Open Frame Door cabinets.

Base Locking Shelf Rest



Locks base shelves in place and prevents shelves from sliding. Designed to allow easy shelf removal. Molded from clear high-strength polycarbonate. Standard feature on all base and tall cabinets.

Mullion Shelf Rest

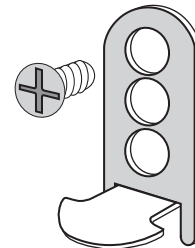

Six position adjustable to allow for superior alignment of shelf with mullion. Metal construction. Standard feature on all Mullion Frame Door cabinets.

These illustrations specify dimensions of vertical stiles, horizontal rails, cabinet heights and standard interior opening heights for Wall cabinets. **Wall cabinets 39" wide and larger feature a 3/4" center stile.**

Wall Cabinets

Wall Cabinet
42" High

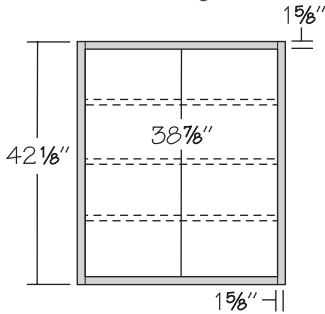

Wall Cabinet
39" High

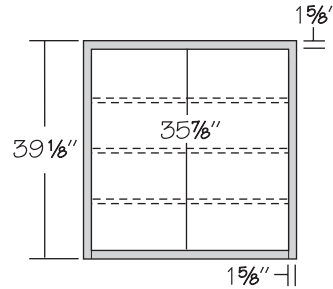

Wall Cabinet
36" High

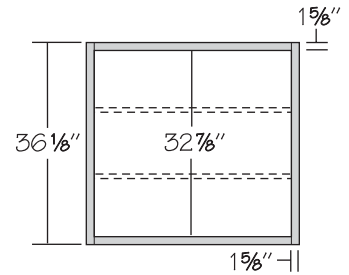

Wall Cabinet
30" High

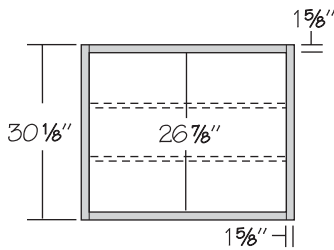

Wall Cabinet
27" High

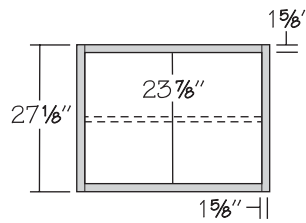

Wall Cabinet
24" High

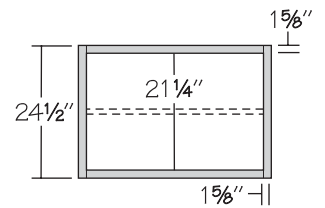

Wall Cabinet
21" High

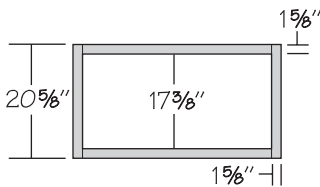

Wall Cabinet
18" High

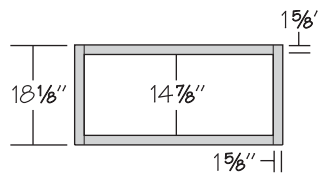

Wall Cabinet
15" High

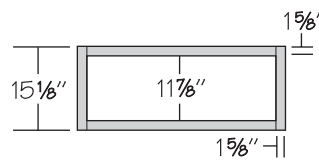

Wall Cabinet
12" High

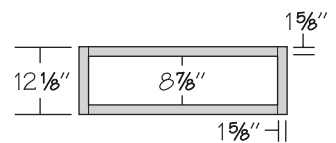

These illustrations specify dimensions of vertical stiles, horizontal rails, inset toe kick, cabinet heights and standard interior opening heights for Base, Drawer Base & Desk cabinets. **Butt door cabinets do not have a center stile.**

Base Cabinets

Inset Toe Kick

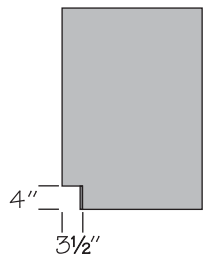

Inset toe kick construction requires BTK8 matching toe kick—must be ordered separately.

Standard Base Cabinet with Butt Doors

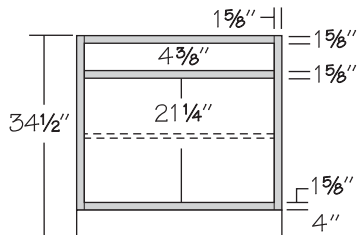

Standard Base Cabinet w/ Center Stile

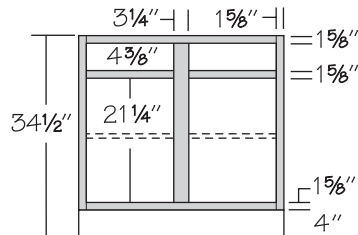

Full-Height Base Cabinet

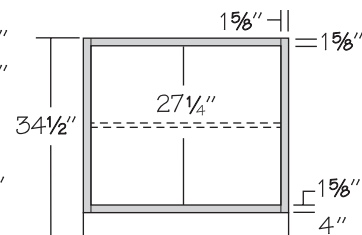

Drawer Base Cabinets

4 Drawer Base Cabinet

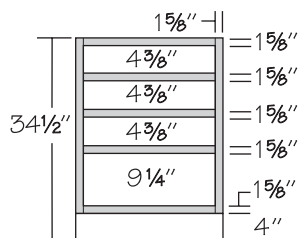

3 Drawer Base Cabinet

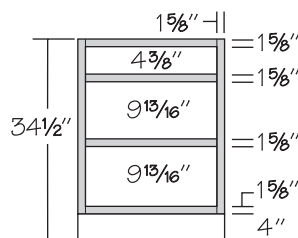

2 Drawer Base Cabinet

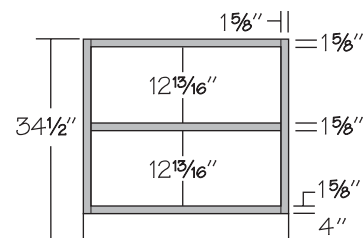

Pedestal Drawer Base Cabinet

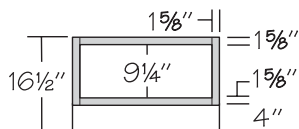

Furniture Drawer Cabinet 12" High

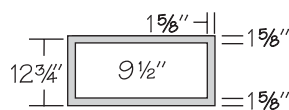

Furniture Drawer Cabinet 6" High

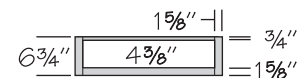

Desk Cabinets

Desk Base Cabinet

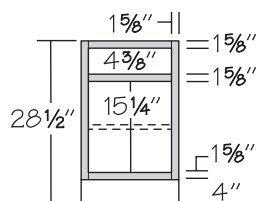

Desk Drawer Cabinet

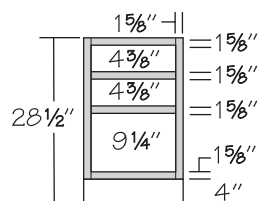

Desk File Pull Out

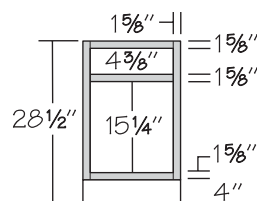

Kneehole Drawer

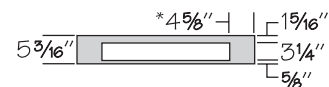

Trimable in height to 4 3/4"

*Dimension for KDC36/33 is 3 1/4"

These illustrations specify dimensions of vertical stiles, horizontal rails, inset toe kick, cabinet heights and standard interior opening heights for Vanity and Universal Design cabinets. **Butt door cabinets do not have a center stile.**

Vanity Cabinets

Vanity Base Cabinet Standard Height

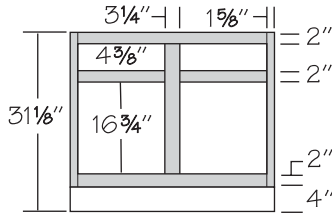

Vanity Drawer Base Standard Height

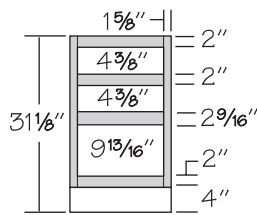

Vanity Base Cabinet Base Height

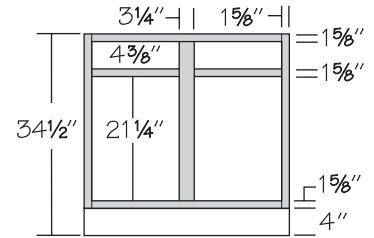

Vanity Drawer Base Base Height

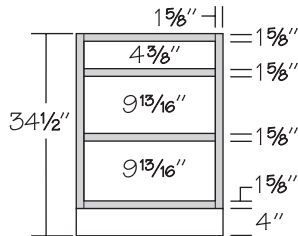

Vanity Full-Height Base Cabinet

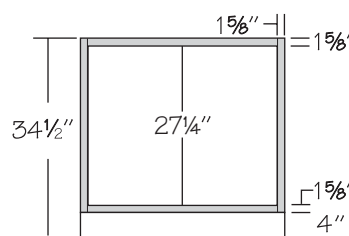

Universal Design Cabinets

Universal Design Base

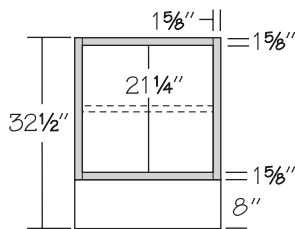

Universal Design Drawer Base

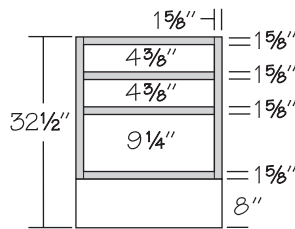

Universal Design Oven Cabinet

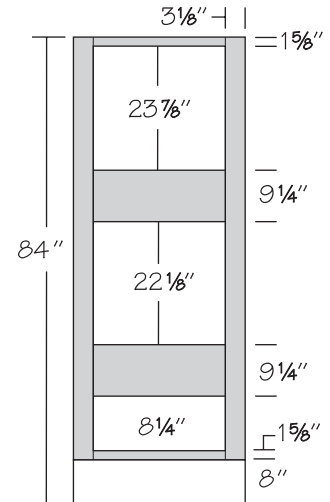

Universal Design Base Multi-Use

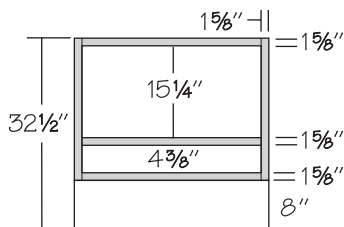

Universal Design Inset Toe Kick

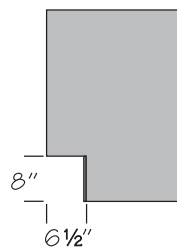

Inset toe kick construction requires BTK8 UD matching toe kick—must be ordered separately.

*Actual height of oven opening shown. For actual width, maximum width and maximum height dimensions, please refer to Cut Out Dimensions Chart in specific cabinet SKU box.

These illustrations specify dimensions of vertical stiles, horizontal rails, inset toe kick, cabinet heights and standard interior opening heights for Utility and Single Oven cabinets.

Tall Cabinets

Utility/Vanity Linen Cabinet
2 Doors or 4 Butt Doors

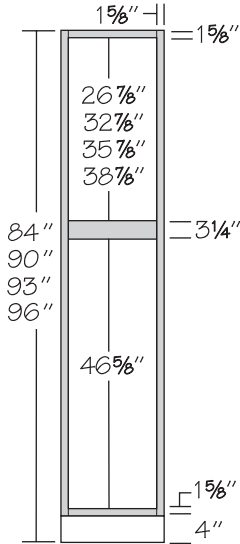

Single Oven Cabinet
4 Butt Doors*

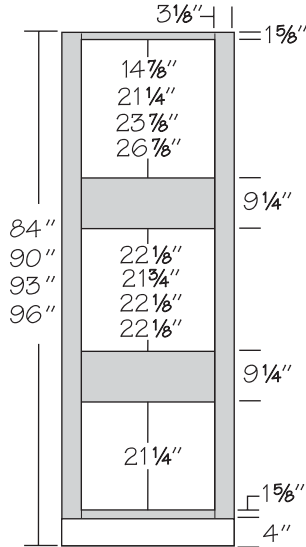

Single Oven Cabinet
4 Butt Doors, 1 Drawer*

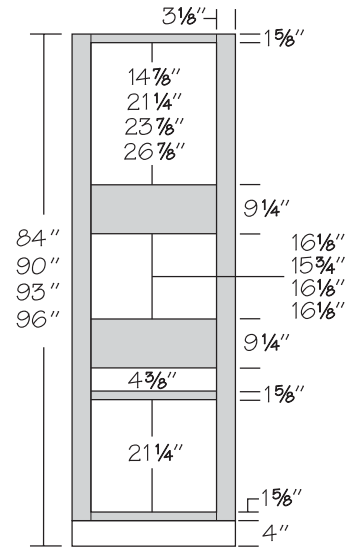

Single Oven Cabinet
4 Butt Doors, 2 Drawers*

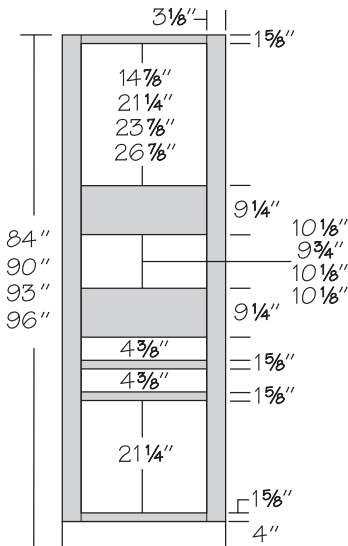

Single Oven Cabinet
2 Butt Doors, 2 Large Drawers*

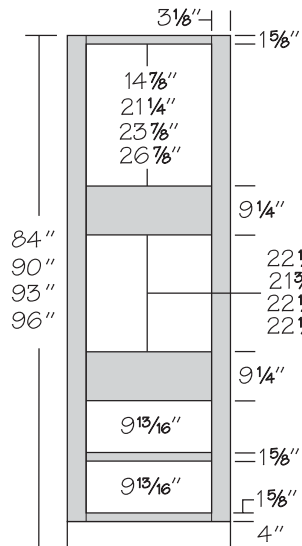

Single Oven Cabinet
2 Butt Doors, 3 Drawers*

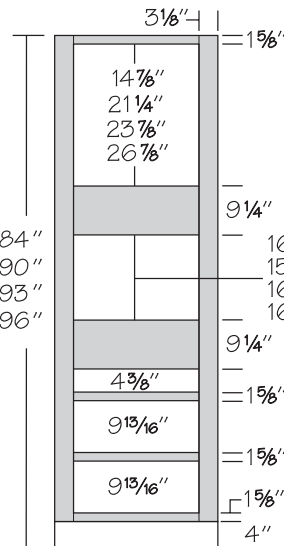

Single Oven Cabinet
2 Butt Doors, 4 Drawers*

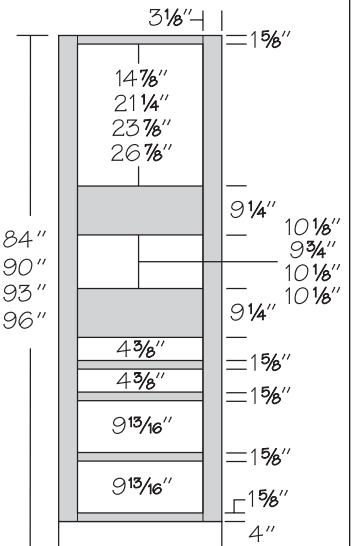

*Actual height of oven opening shown. For actual width, maximum width and maximum height dimensions, please refer to Cut Out Dimensions Chart in specific cabinet SKU box.

These illustrations specify dimensions of vertical stiles, horizontal rails, inset toe kick, cabinet heights and standard interior opening heights for Double Oven cabinets.

Tall Cabinets

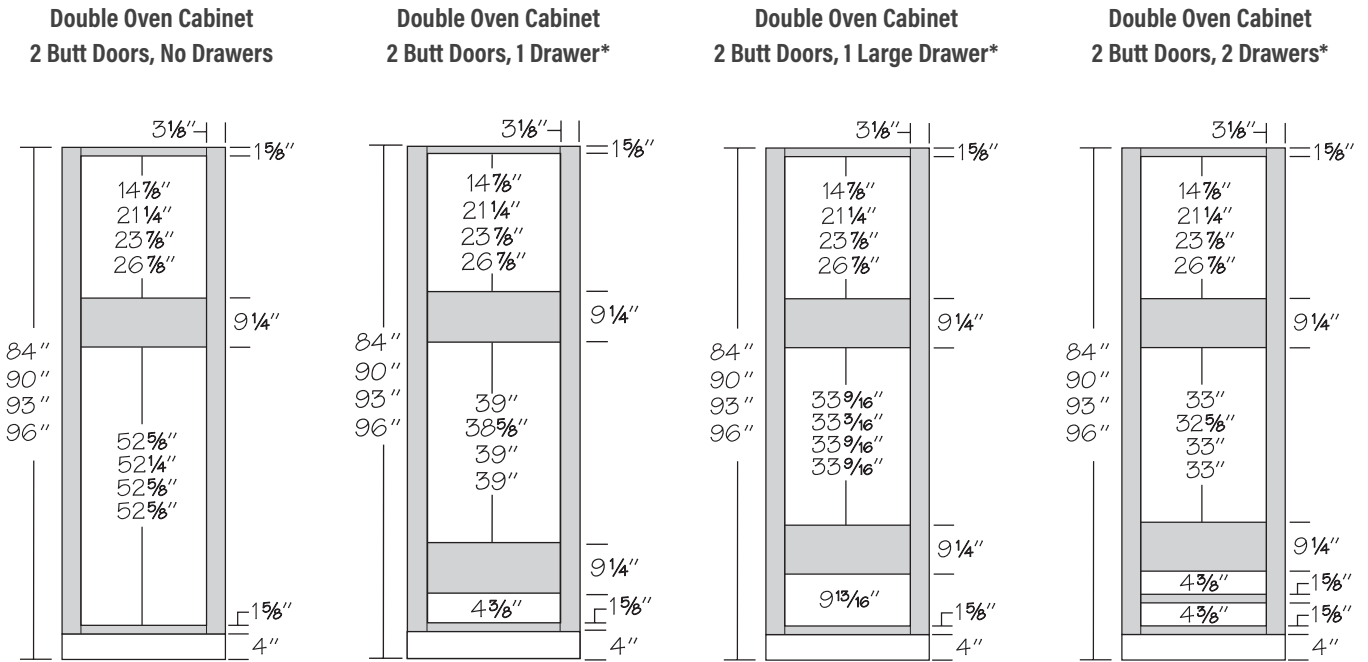

*Actual height of oven opening shown. For actual width, maximum width and maximum height dimensions, please refer to Cut Out Dimensions Chart in specific cabinet SKU box.

Ceiling Height Requirements for Tall Cabinets

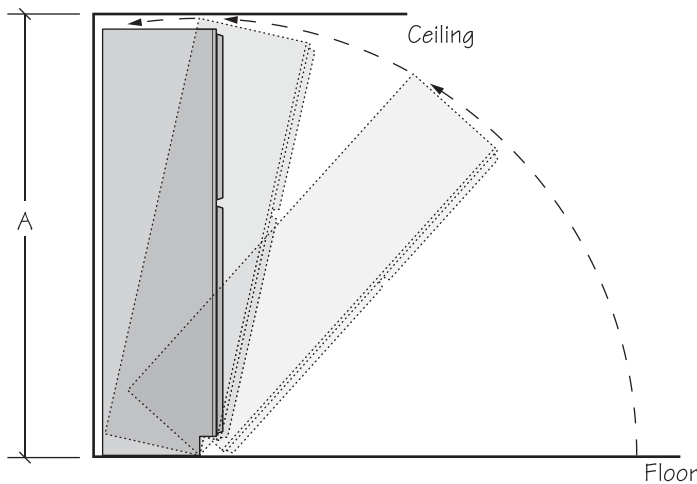

Notes

- 93" and 96" high Tall cabinets are shipped with 4" inset toe kick assembly shipped inside cabinet.

Height	Cabinet Depth	Minimum Ceiling Height A
84"	12"	84 9/16"
84"	18"	85 1/4"
84"	24"	86 1/2"
90"	12"	90 1/2"
90"	18"	91 5/16"
90"	24"	92 5/16"
93"	12"	93"
93"	18"	93"
93"	24"	93"
96"	12"	96"
96"	18"	96"
96"	24"	96"

These illustrations specify dimensions of the height requirements for top alignment of Wall and Tall cabinets (Linen, Utility, Oven) installation.

84" Top Alignment Cabinet Installation

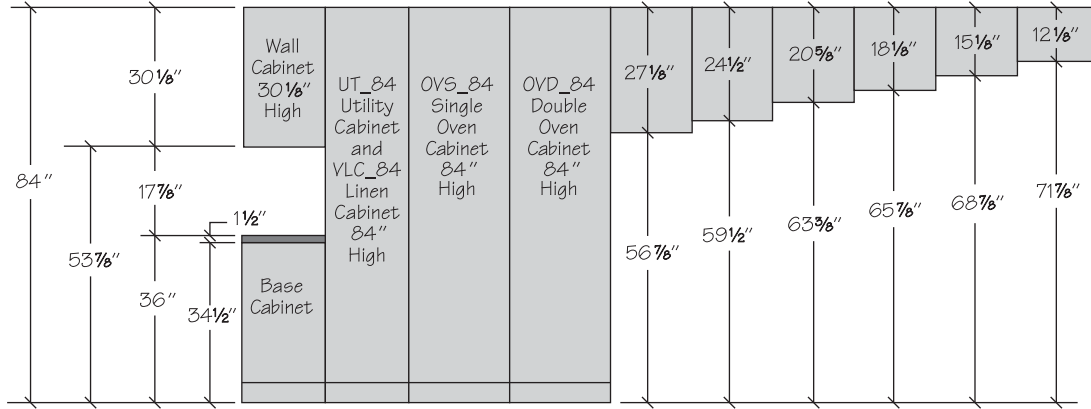

Notes:

- 84" top alignment cabinet installation includes standard Wall cabinets (30 1/8" high) installed 53 7/8" above the finished floor, allowing 17 7/8" clearance between the Wall cabinets and a standard countertop height of 36".
- Tall cabinetry (Linen, Utility, Oven) is 84" high.
- **When selecting cabinetry for installation above or near any appliance, refer to the appliance manufacturer's specifications for clearance and venting requirements.**

90" Top Alignment Cabinet Installation

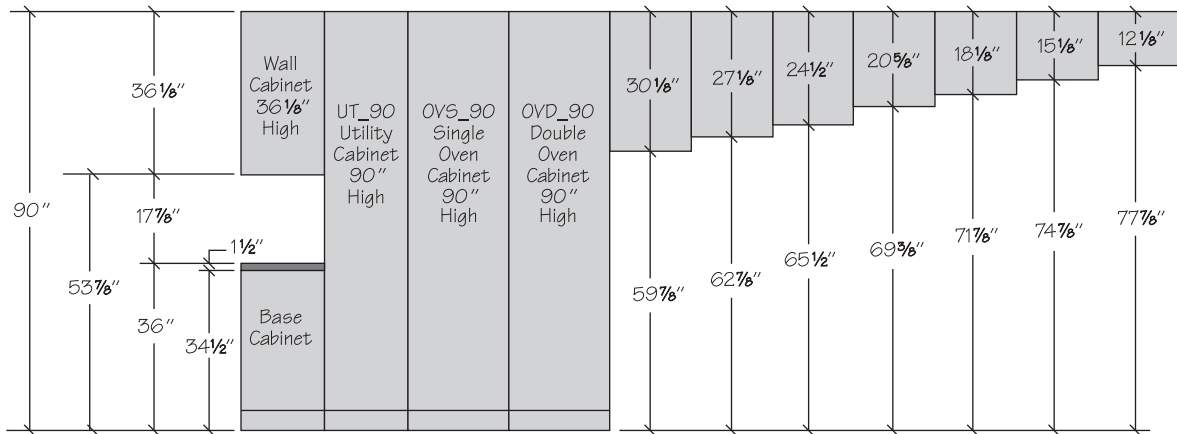

Notes:

- 90" top alignment cabinet installation includes 36 1/8" high Wall cabinets installed 53 7/8" above the finished floor, allowing 17 7/8" clearance between the Wall cabinets and a standard countertop height of 36".
- Tall cabinetry (Utility, Oven) is 90" high.
- **When selecting cabinetry for installation above or near any appliance, refer to the appliance manufacturer's specifications for clearance and venting requirements.**

93" Top Alignment Cabinet Installation

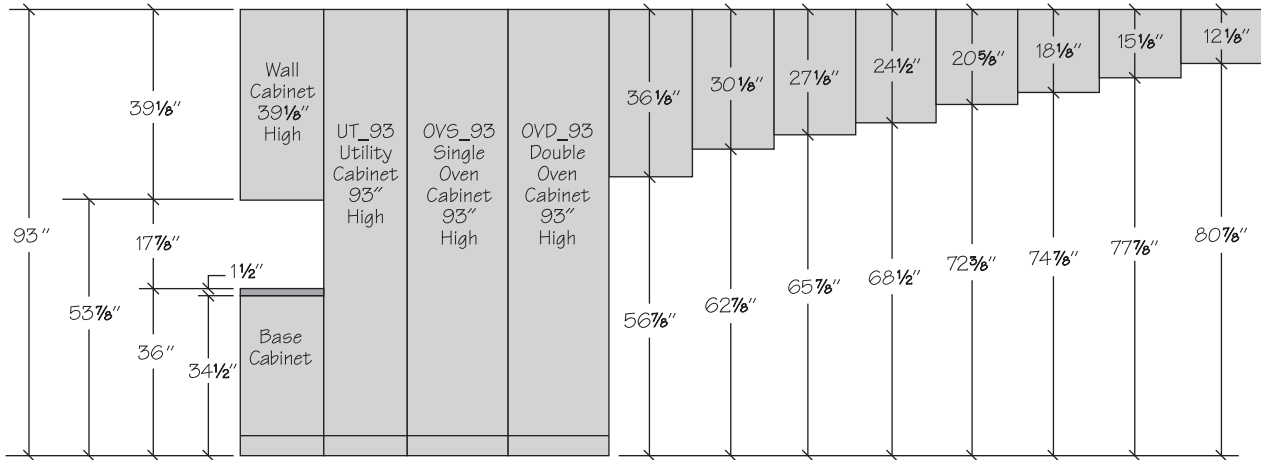

Notes:

- 93" top alignment cabinet installation includes 39 1/8" high Wall cabinets installed 53 7/8" above the finished floor, allowing 17 7/8" clearance between the Wall cabinets and a standard countertop height of 36".
- Tall cabinetry (Utility, Oven) is 93" high.
- **When selecting cabinetry for installation above or near any appliance, refer to the appliance manufacturer's specifications for clearance and venting requirements.**

96" Top Alignment Cabinet Installation

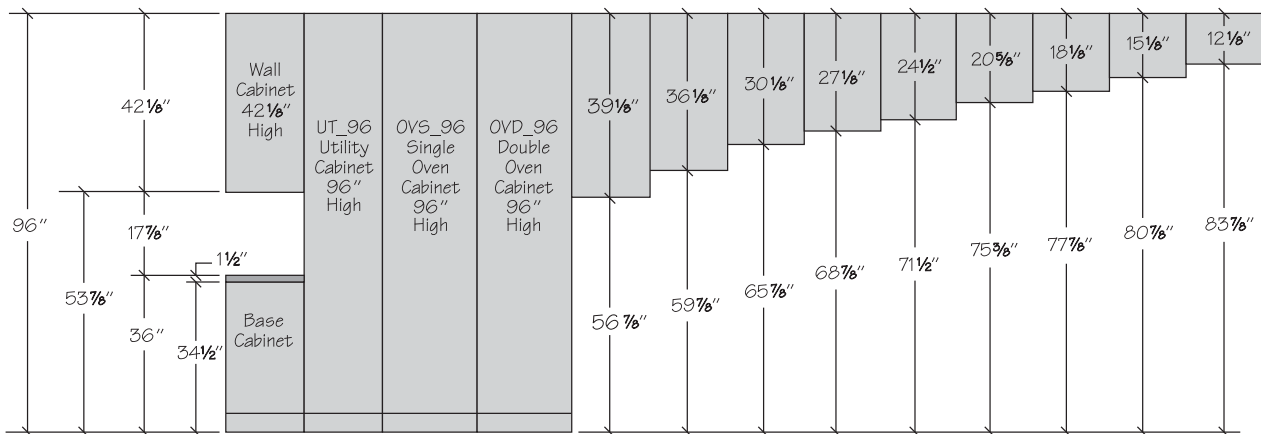

Notes:

- 96" top alignment cabinet installation includes 42 1/8" high Wall cabinets installed 53 7/8" above the finished floor, allowing 17 7/8" clearance between the Wall cabinets and a standard countertop height of 36".
- Tall cabinetry (Utility, Oven) is 96" high.
- **When selecting cabinetry for installation above or near any appliance, refer to the appliance manufacturer's specifications for clearance and venting requirements.**

These drawings illustrate the relationship between the cabinet face frame and Full Overlay (FOL) and Standard Overlay (SOL) doors. They show the amount of the cabinet face frame that is visible when Full Overlay doors or Standard Overlay doors are selected.

Full Overlay

Full Overlay (FOL) doors are sized to cover nearly all of the cabinet face frame. Full Overlay door styles require decorative hardware. **To facilitate proper door operation, include at least a 1" filler between the hinged side of Full Overlay door styles and deeper adjacent objects including cabinets, walls, appliances and countertops.**

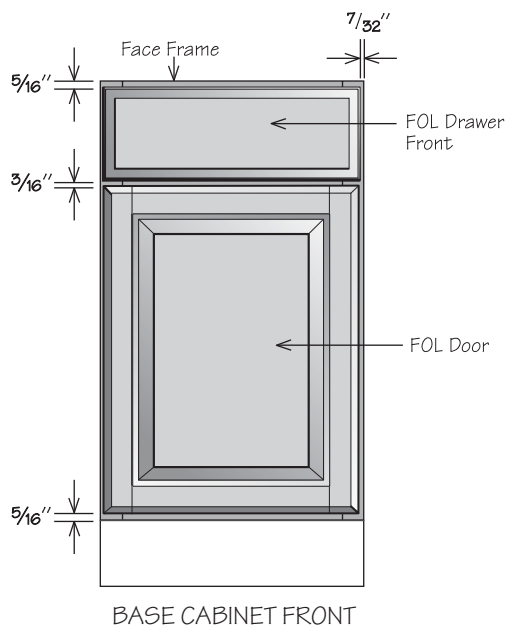
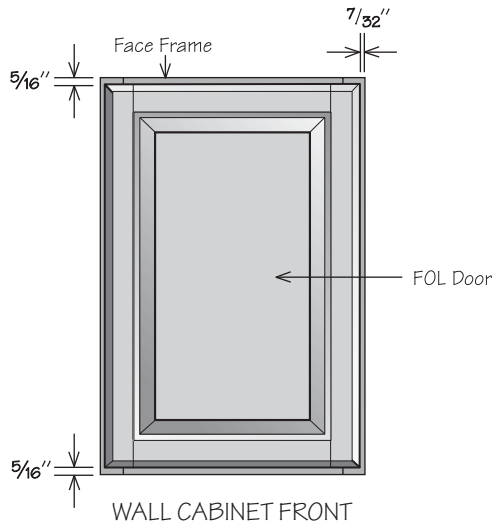

Standard Overlay

Standard Overlay (SOL) doors are sized to show about an inch of the cabinet face frame, giving the door some visual depth.

