

# MACCK<sup>®</sup>

vocational

- Dump
- Construction



## GRANITE

AXLE BACK

Medium Heavy Duty

**4x2**

**GU532**

### STANDARD POWERTRAIN SPECIFICATIONS

#### **ENGINE: Cummins ISL9 345**

Peak Horsepower – 345HP at 1900 RPM  
Horsepower – 330 HP at 2100 Gov. RPM  
Max. Torque – 1150 lb/ft at 1400 RPM  
V-MAC IV – Total Vehicle Electronics  
Air Compressor – 318 (18.7 cfm)  
Air Cleaner – 11" Single Element  
Alternator – Delco 12V 130A (24SI)  
Batteries, (2) Mack 12V 1000/2000 CCA Threaded Stub Type  
Coolant Protection, -34°F (-37°C)  
Diesel Particulate Filter – Horizontal RH Side Under Cab  
Exhaust After Treatment System – Cummins Diesel  
Particulate Filter with SCR  
Silicone Engine Hoses and Tubing  
Poly-V Fan Belt w/Automatic Tensioner  
Fan Drive, Horton DMA2S Multispeed On/Off  
Flywheel Housing – Aluminum (Lightweight)  
Fuel Water Separator w/Water in Fuel Sensor  
Mack EPDM Radiator & Heater Hoses  
Radiator – Aluminum Core  
Starter – 12V Gear Reduction  
Electronic Starter Interlock  
Electric Preheater

#### **TRANSMISSION: Eaton FRO 11210C**

10-Speed, Ratios: 12.69 Low – 0.74 High  
Clutch – Eaton Advantage EZ Pedal - 15.5" 7-Spring, 2 Plate  
Ceramic 4 Paddle Manual Adjust  
Mechanical Cable Clutch  
Transmission Bell Housing – Iron  
Main Driveline –  
Meritor 17 MXL  
Xtended Lube™

SPECIFICATIONS



**STANDARD POWERTRAIN SPECIFICATIONS** (Continued)

**REAR AXLE: Meritor RS21-145**

21,000 lb Capacity  
Tires – 11R22.5  
Carrier – Meritor Single Reduction  
Wheels – Steel Disc (8) 22.5" x 8.25" 10-Hole Hub Piloted  
Hub Material – Ferrous  
Brakes – Bendix "S" Cam 16.5" x 7" Cast Spider  
Brake Drums – Cast Outboard Mounted  
Rear Brake Lining  
Rear Wheel Seals  
Slack Adjusters – Automatic  
Suspension – 21,000 lb. Multi-Leaf  
Spring Brake Chambers – (2) 30/30 Double Diaphragm Type/Mechanical Spring Release

**FRONT AXLE: MACK FXL12**

12,000 lb. Capacity  
Tires – 11R22.5  
Wheels – Steel Disc (2) 22.5" x 8.25" 10-Hole Hub Piloted  
Hub Material – Ferrous  
Brakes – Bendix "S" Cam 16.5" x 5" Cast Spider  
Brake Drums – Cast Outboard Mounted  
Front Brake Lining  
Front Wheel Seals – Integrated  
Shock Absorbers – Double Acting Type  
Slack Adjusters – Automatic  
Suspension – Mack Taperleaf 12,000 lb. Ground Load Rating (2 Leaf Spring)  
Steering – TRW TAS66

**STANDARD CAB INTERIOR/EXTERIOR SPECIFICATIONS**

**CAB: CA68 CONVENTIONAL**

Integral Heater  
Ash Tray  
Cab Mounting – Four Point System w/2 Air Bags and Shocks at Rear  
Cigar Lighter  
Coat Hook  
Co-Pilot Enhanced Driver Display with Button and Stalk Control  
Cup Holders, Driver's & Rider's Side  
Dome Lights, 2 Lamps LH/ 2 Lamps RH  
Galvanized Steel Visibility Doors  
Door Trim – Padded w/Vinyl Arm Rest Pads  
Engine Shutoff – Key Type  
Floor Mats, Mack Signature Polyurethane  
Gauges – Air Pressure, Engine Coolant Temperature, Engine Oil Pressure, Engine Oil Temperature, Speedometer, Tachometer, Fuel Level  
Gauge Cluster – Exhaust Pyrometer & Transmission Oil Temperature Gauges  
Grab Handles, Aluminum RH & LH Behind Door  
Grille – Radiator Mounted w/Black Finished Bars w/o Grille Surround  
Hood – DCPD Liquid Mold Resin with Forward tilt 75°  
Fenders – High Impact Polypropylene w/Wheel Splash Aprons and Black Polyarmour Mud Flaps  
Horn – Twin Under Cab Trumpet  
Identification and Clearance Lights (5)  
Instrument Panel – Charcoal w/Black Gage Bezel  
Interior Trim: Purebred – Slate Gray  
Keys – (2) Keyed at Random

Low Air Pressure Indicator Light and Buzzer  
Exterior Mirrors –RH & LH Bulldog Bright Finish w/Stainless Steel Arms  
Overhead Console, 2 Storage Compartments w/Net Retainers with Center Mounting for CB Provisions  
Parking Brake On Indicator Light  
12 Volt Auxiliary Power Outlets (2) – Dash Mounted  
Radio Accommodation Package includes: Antenna, Power Supply, 2-Speakers (No Radio)  
Driver Seat – Bostrom Talladega 915 Mid-Back Air Suspension  
Seat Belts – Lap and Shoulder w/Cab Mounted Shoulder Belt  
Key Type Starter Switch  
Steering Column, Fixed  
Steering Wheel – Two Spoke Urethane Grip Painted Spokes & Bulldog Horn Cap  
Interior Sun Visor- Driver Side Only  
Window Control – Hand Crank Operation  
Windshield – Safety Tinted 2 Piece  
Safety Tinted Side and Rear Windows  
Windshield Washers – Electric Wiper with Reservoir Mounted on Back of Cab  
Windshield Wipers – 2 Speed Electric Motor w/Intermittent Feature  
Paint Color – Mack White (Cab, Hood & Fenders), Mack Black (Chassis Running Gear)



**ADDITIONAL STANDARD SPECIFICATIONS**

**AIR/BRAKE**

Dual Air Brake System  
Heated Air Dryer - 1200P w/Coalescing Filter  
Air Reservoirs – Steel  
Anti-Lock Brake System w/o Traction Control  
Parking Brake Control – Single Valve System

**ELECTRICAL**

12 Volt Electrical System  
Battery Box – Steel w/Molded Plastic Cover Mounted RH Rail Only  
Courtesy Light Switch – Headlamp and Clearance  
Daytime Running Lights  
Electric Circuit Protection Package  
Body Link III  
Waterproof Electrical Connections  
Headlights – Halogen Flush  
Solid State Turn Signal Flasher

**STANDARD CHASSIS DIMENSIONS**

(All measurements are in inches)

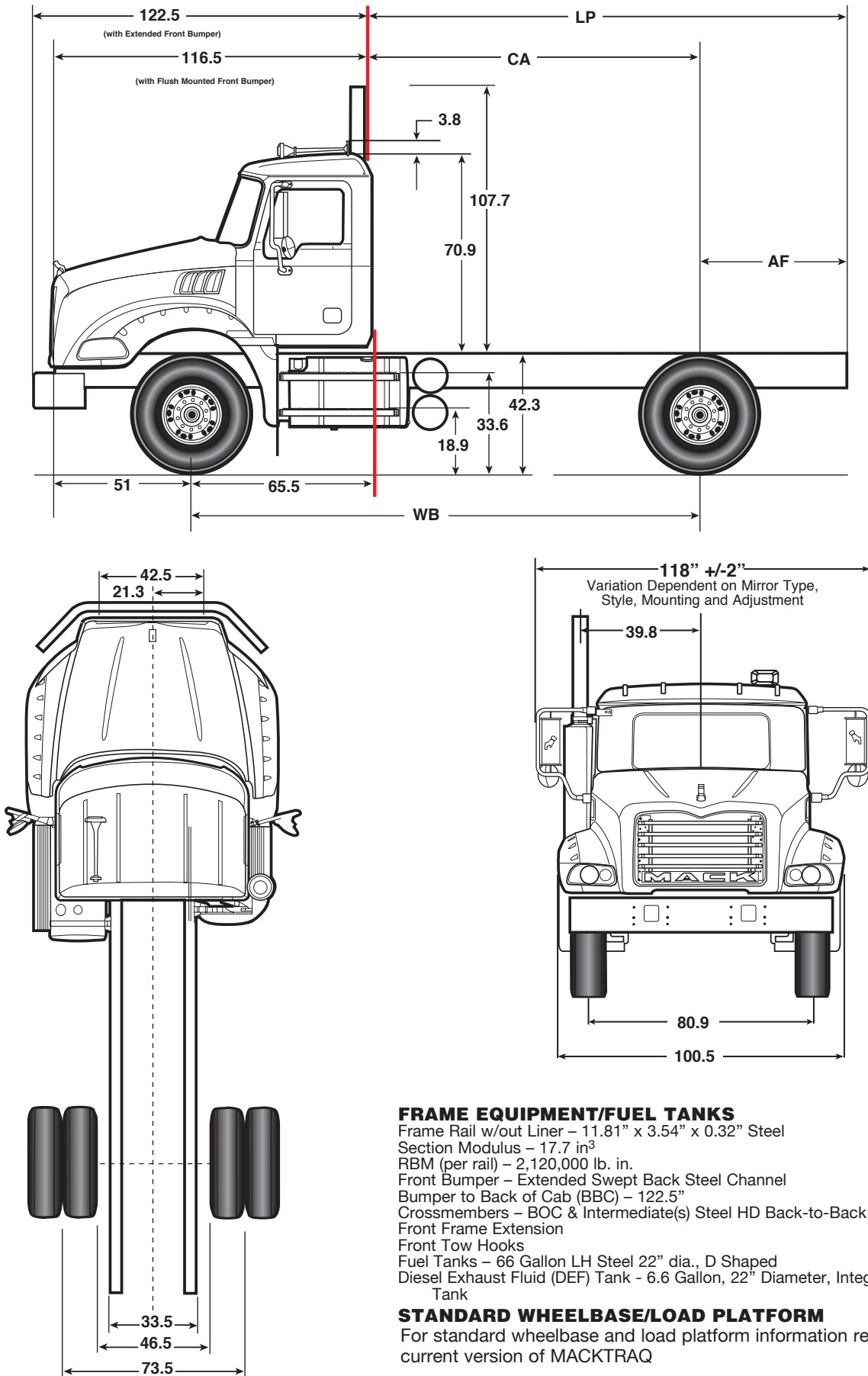

**FRAME EQUIPMENT/FUEL TANKS**

- Frame Rail w/out Liner – 11.81" x 3.54" x 0.32" Steel
- Section Modulus – 17.7 in<sup>3</sup>
- RBM (per rail) – 2,120,000 lb. in.
- Front Bumper – Extended Swept Back Steel Channel
- Bumper to Back of Cab (BBC) – 122.5"
- Crossmembers – BOC & Intermediate(s) Steel HD Back-to-Back Channel
- Front Frame Extension
- Front Tow Hooks
- Fuel Tanks – 66 Gallon LH Steel 22" dia., D Shaped
- Diesel Exhaust Fluid (DEF) Tank - 6.6 Gallon, 22" Diameter, Integrated w/Fuel Tank

**STANDARD WHEELBASE/LOAD PLATFORM**

For standard wheelbase and load platform information refer to your current version of MACKTRAQ

**AVAILABLE DRIVELINE COMPONENTS**

<b>TRANSMISSIONS</b>		
<b>MODEL</b>	<b>SPEEDS</b>	<b>RATIOS (LOW/HIGH)</b>
<b>ALLISON</b>		
3000-RDS	5	3.49/0.75
3000-RDS	6	3.49/0.65
<b>EATON FULLER</b>		
RTX-11609B	9	12.57/0.73
FRO-11210B	10	11.06/0.75
FRO-11210C	10	12.69/0.74
RTO-11908LL	10	14.56/0.74
RT-11909ALL	11	26.08/0.73

<b>ENGINE</b>	
<b>MODEL</b>	<b>HORSEPOWER</b>
<b>CUMMINS</b>	
ISL9 345	345 HP [257 kW] @ 1900 RPM 330 HP [244 kW] @ 2100

<b>AXLES</b>		
<b>CAPACITY</b>	<b>MAKE</b>	<b>MODEL</b>
<b>FRONT AXLES</b>		
12,000 lb. [5 443 kg]	MACK	FXL12
14,600 lb. [6 600kg]	MACK	FXL14.6
18,000 lb. [8 165 kg]	MACK	FXL18
20,000 lb. [9 072 kg]	MACK	FXL20
<b>REAR AXLES</b>		
21,000 lb. [9 545 kg]	MERITOR	RS21-145
23,000 lb. [10 433 kg]	MERITOR	RS23-160
26,000 lb. [11 818 kg]	MERITOR	RS26-185
30,000 lb. [13 608 kg]	MERITOR DANA SPICER	RS30-185 S30-190



**A SALES ENGINEERING PUBLICATION**

The information in this brochure was accurate as of the date of the publication. Illustrations may not be representative of current product. Mack Trucks, Inc. reserves the right to make changes in specifications, equipment or design, or to discontinue models or options without notice at any time.



# MACCK<sup>®</sup>

vocational

- Dump
- Construction



## GRANITE

AXLE BACK  
Medium Heavy Duty

**6x4**  
GU533

### STANDARD POWERTRAIN SPECIFICATIONS

#### ENGINE: Cummins ISL9 345

Peak Horsepower – 345HP at 1900 RPM  
Horsepower – 330 HP at 2100 Gov. RPM  
Max. Torque – 1150 lb/ft at 1400 RPM  
V-MAC IV – Total Vehicle Electronics  
Air Compressor – 318 (18.7 cfm)  
Air Cleaner – 11" Single Element  
Alternator – Delco 12V 130A (24SI)  
Batteries, (2) Mack 12V 1000/2000 CCA Threaded Stub Type  
Coolant Protection, -34°F (-37°C)  
Diesel Particulate Filter – Horizontal RH Side Under Cab  
Exhaust After Treatment System – Cummins Diesel  
Particulate Filter with SCR  
Silicone Engine Hoses and Tubing  
Poly-V Fan Belt w/Automatic Tensioner  
Fan Drive, Horton DMA2S Multispeed On/Off  
Flywheel Housing – Aluminum (Lightweight)  
Fuel Water Separator w/Water in Fuel Sensor  
Mack EPDM Radiator & Heater Hoses  
Radiator – Aluminum Core  
Starter – 12V Gear Reduction  
Electronic Starter Interlock  
Electric Preheater

#### TRANSMISSION: Eaton FRO 11210C

10-Speed, Ratios: 12.69 Low –0.74High  
Clutch – Eaton Advantage EZ Pedal  
15.5" 7-Spring, 2 Plate Ceramic  
4 Paddle Manual Adjust  
Mechanical Cable Clutch  
Transmission Bell Housing- Iron  
Main Driveline–  
Meritor 17 MXL "Xtended Lube"  
Interaxle Driveline –  
Meritor 17 MXL  
"Xtended Lube"

SPECIFICATIONS



## STANDARD POWERTRAIN SPECIFICATIONS *(Continued)*

### **REAR AXLE: Meritor MT40-14X**

40,000 lb Capacity  
Tires – 11R22.5  
Carrier – Meritor Single Reduction  
Wheels – Steel Disc (8) 22.5" x 8.25" 10-Hole Hub Piloted  
Hub Material – Ferrous  
Brakes – Bendix "S" Cam 16.5" x 7" Cast Spider  
Brake Drums – Cast Outboard Mounted  
Rear Brake Lining  
Rear Wheel Seals  
Slack Adjusters – Automatic  
Suspension – Mack AL Air Suspension 40K  
Spring Brake Chambers – (4) 30/30 Double Diaphragm Type/Mechanical Spring Release

### **FRONT AXLE: MACK FXL12**

12,000 lb. Capacity  
Tires – 11R22.5  
Wheels – Steel Disc (2) 22.5" x 8.25" 10-Hole Hub Piloted  
Hub Material – Ferrous  
Brakes – Bendix "S" Cam 16.5" x 5" Cast Spider  
Brake Drums – Cast Outboard Mounted  
Front Brake Lining  
Front Wheel Seals – Integrated  
Shock Absorbers – Double Acting Type  
Slack Adjusters – Automatic  
Suspension – Mack Taperleaf 12,000 lb. Ground Load Rating (2 Leaf Spring)  
Steering – TRW TAS66

## STANDARD CAB INTERIOR/EXTERIOR SPECIFICATIONS

### **CAB: CA68 CONVENTIONAL**

Integral Heater  
Ash Tray  
Cab Mounting – Four Point System w/2 Air Bags and Shocks at Rear  
Cigar Lighter  
Coat Hook  
Co-Pilot Enhanced Driver Display with Button and Stalk Control  
Cup Holders, Driver's & Rider's Side  
Dome Lights, 2 Lamps LH/ 2 Lamps RH  
Galvanized Steel Visibility Doors  
Door Trim – Padded w/Vinyl Arm Rest Pads  
Engine Shutoff – Key Type  
Floor Mats, Mack Signature Polyurethane  
Gauges – Air Pressure, Engine Coolant Temperature, Engine Oil Pressure, Engine Oil Temperature, Speedometer, Tachometer, Fuel Level  
Gauge Cluster – Exhaust Pyrometer & Transmission Oil Temperature Gauges  
Grab Handles, Aluminum RH & LH Behind Door  
Grille – Radiator Mounted w/Black Finished Bars w/o Grille Surround  
Hood – DCPD Liquid Mold Resin with Forward tilt 75°  
Fenders – High Impact Polypropylene w/Wheel Splash Aprons and Black Polyarmour Mud Flaps  
Horn – Twin Under Cab Trumpet  
Identification and Clearance Lights (5)  
Instrument Panel – Charcoal w/Black Gage Bezel  
Interior Trim: Purebred – Slate Gray  
Keys – (2) Keyed at Random  
Low Air Pressure Indicator Light and Buzzer

Exterior Mirrors –RH & LH Bulldog Bright Finish w/Stainless Steel Arms  
Overhead Console, 2 Storage Compartments w/Net Retainers with Center Mounting for CB Provisions  
Parking Brake On Indicator Light  
12 Volt Auxiliary Power Outlets (2) – Dash Mounted  
Radio Accommodation Package includes: Antenna, Power Supply, 2-Speakers (No Radio)  
Driver Seat – Bostrom Talladega 915 Mid-Back Air Suspension  
Seat Belts – Lap and Shoulder w/Cab Mounted Shoulder Belt  
Key Type Starter Switch  
Steering Column, Fixed  
Steering Wheel – Two Spoke Urethane Grip Painted Spokes & Bulldog Horn Cap  
Interior Sun Visor- Driver Side Only  
Window Control – Hand Crank Operation  
Windshield – Safety Tinted 2 Piece  
Safety Tinted Side and Rear Windows  
Windshield Washers – Electric Wiper with Reservoir Mounted on Back of Cab  
Windshield Wipers – 2 Speed Electric Motor w/Intermittent Feature  
Paint Color – Mack White (Cab, Hood & Fenders), Mack Black (Chassis Running Gear)



## ADDITIONAL STANDARD SPECIFICATIONS

### **AIR/BRAKE**

Dual Air Brake System  
Heated Air Dryer - 1200P w/Coalescing Filter  
Air Reservoirs – Steel  
Anti-Lock Brake System w/o Traction Control  
Parking Brake Control – Single Valve System

### **ELECTRICAL**

12 Volt Electrical System  
Battery Box – Steel w/Molded Plastic Cover Mounted RH Rail Only  
Courtesy Light Switch – Headlamp and Clearance  
Daytime Running Lights  
Electric Circuit Protection Package  
Body Link III  
Waterproof Electrical Connections  
Headlights – Halogen Flush  
Solid State Turn Signal Flasher

**STANDARD CHASSIS DIMENSIONS**

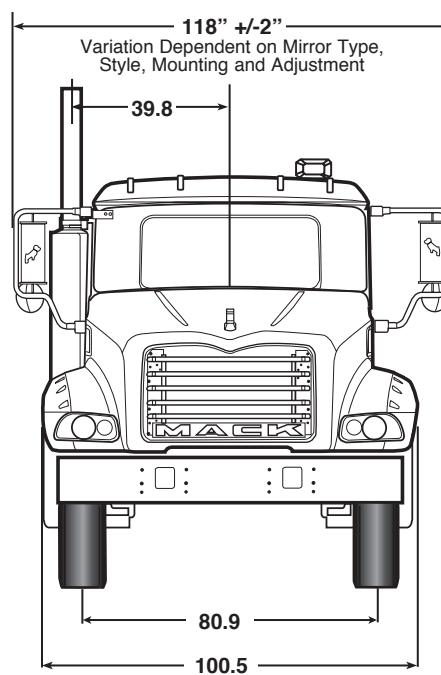
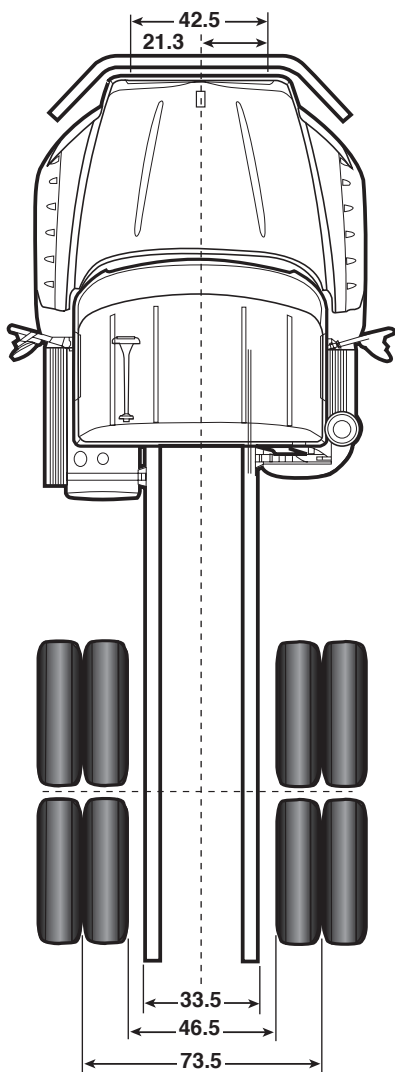
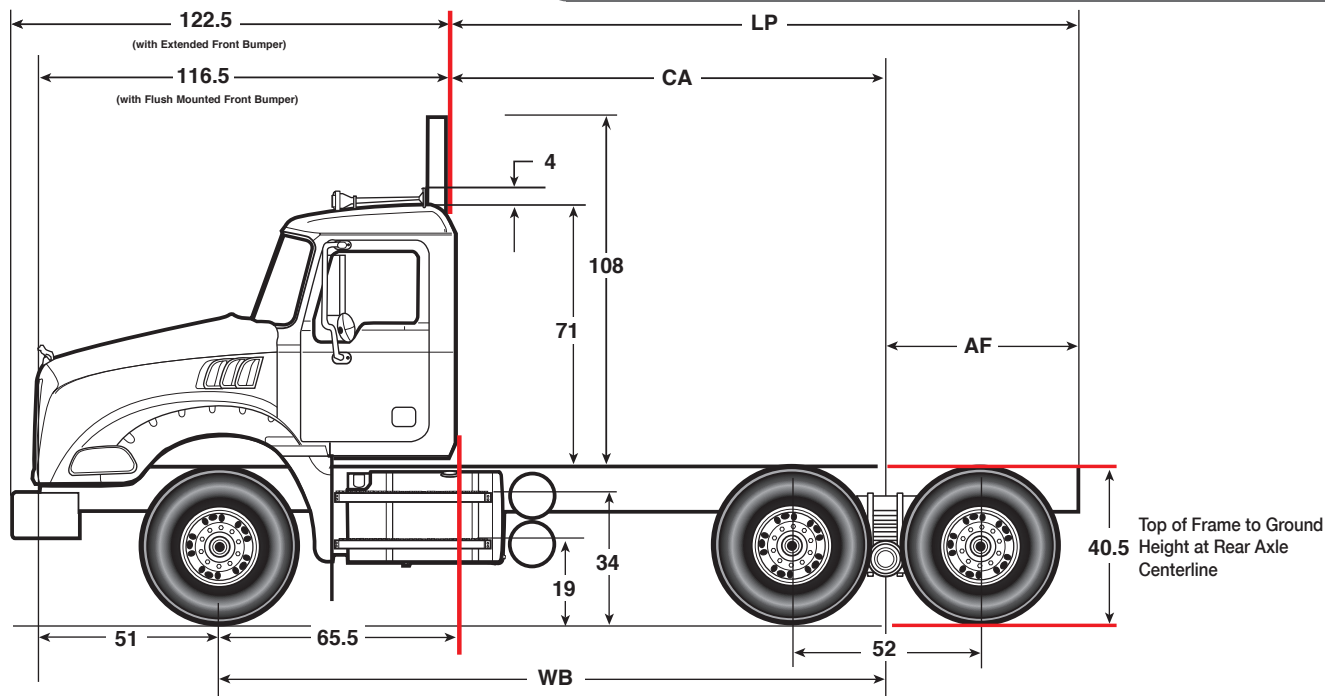

**FRAME EQUIPMENT/FUEL TANKS**

- Frame Rail w/out Liner – 11.81" x 3.54" x 0.32" Steel
- Section Modulus – 17.7 in<sup>3</sup>
- RBM (per rail) – 2,120,000 lb. in.
- Front Bumper – Extended Swept Back Steel Channel
- Bumper to Back of Cab (BBC) – 122.5"
- Crossmembers – BOC & Intermediate(s) Steel HD Back-to-Back Channel
- Front Frame Extension
- Front Tow Hooks
- Fuel Tanks – 66 Gallon LH Steel 22" dia., D Shaped
- Diesel Exhaust Fluid (DEF) Tank – 6.6 Gallon, 22" Diameter, Integrated w/Fuel Tank

**STANDARD WHEELBASE/LOAD PLATFORM**

For standard wheelbase and load platform information refer to your current version of MACKTRAQ



**AVAILABLE DRIVELINE COMPONENTS**

<b>TRANSMISSIONS</b>		
<b>MODEL</b>	<b>SPEEDS</b>	<b>RATIOS (LOW/HIGH)</b>
<b>ALLISON</b>		
3000-RDS	5	3.49/0.75
3000-RDS	6	3.49/0.65
<b>EATON FULLER</b>		
RTX-11609B	9	12.57/0.73
FRO-11210B	10	11.06/0.75
FRO-11210C	10	12.69/0.74
RTO-11908LL	10	14.56/0.74
RT-11909ALL	11	26.08/0.73

<b>ENGINE</b>	
<b>MODEL</b>	<b>HORSEPOWER</b>
<b>CUMMINS</b>	
ISL9 345	345 HP [257 kW] @ 1900 RPM 330 HP [244 kW] @ 2100

<b>AXLES</b>		
<b>CAPACITY</b>	<b>MAKE</b>	<b>MODEL</b>
<b>FRONT AXLES</b>		
12,000 lb. [5 443 kg]	MACK	FXL12
14,600 lb. [6 600 kg]	MACK	FXL14.6
16,500 lb. [7 500 kg]	MACK	FXL16.5
<b>REAR AXLES</b>		
40,000 lb. [18 144 kg]	DANA SPICER	DS405/DS405P
	MERITOR	MT40-14X

**A SALES ENGINEERING PUBLICATION**

The information in this brochure was accurate as of the date of the publication. Illustrations may not be representative of current product. Mack Trucks, Inc. reserves the right to make changes in specifications, equipment or design, or to discontinue models or options without notice at any time.

