

**THIS STANDARD PRACTICE WAS DEVELOPED AS A GUIDE TO ASSIST THE ACPA INFRASTRUCTURE COMMITTEE'S MARKET TEAMS IN CREATING OR MODIFYING SPECIFICATIONS IN THEIR MARKET AREAS. IT IS EXPECTED THAT CERTAIN PORTIONS OF THIS STANDARD MAY NOT BE APPLICABLE TO ALL MARKETS. SOME OF THE CONTENTS IN THIS DOCUMENT COULD BE COPYRIGHTED. AS SUCH, THE USER SHOULD NOT "CUT AND PASTE" LARGE SECTIONS OF THIS DOCUMENT AND PLACE INTO A NEW OR EXISTING SPECIFICATION. THIS IS AN INTERNAL DOCUMENT INTENDED FOR THE USE OF ACPA MEMEBERS WORKING WITH AGENCIES TO IMPROVE THEIR SPECIFICATIONS, BUT IT SHOULD NOT BE DISTRIBUTED TO OUTSIDE AGENCIES.**

## **STANDARD PRACTICE FOR THE DESIGN AND CONSTRUCTION OF REINFORCED CONCRETE STORM SEWER PIPE (RCP)**

### **PART 1: GENERAL**

#### **1.01 SCOPE OF WORK**

Furnish all labor, materials, equipment and incidentals necessary to manufacture and test reinforced concrete gravity sewer pipe and fittings as shown on the drawings and specified herein.

#### **1.02 REFERENCE SPECIFICATIONS**

Except as modified or supplemented herein, all precast reinforced concrete pipe shall conform to the applicable requirements of the following specifications, latest edition.

- A. AASHTO (American Association of State Highway and Transportation Officials)
  - AASHTO LRFD Bridge Design Specifications
  - M288 Standard Specification for Geosynthetic Specification for Highway Applications
  - PP63 Standard Practice for Pipe Joint Selection for Highway Culvert and Storm Drains
  - R73 Standard Practice for Evaluation of Precast Concrete Drainage Products
- B. ASCE (American Society of Civil Engineers)
  - ASCE 15 Standard Practice for Direct Design of Buried Precast Concrete Pipe Using Standard Installations (SIDD)
- C. ASTM (ASTM International)
  - C76 Standard Specifications for Reinforced Concrete Culvert, Storm Drain and Sewer Pipe
  - C443 Standard Specification for Joints for Concrete Pipe and Manholes, Using Rubber Gaskets
  - C506 Standard Specification for Reinforced Concrete Arch Culvert, Storm Drain, and Sewer Pipe
  - C507 Standard Specification for Reinforced Concrete Elliptical Culvert, Storm Drain, and Sewer Pipe

C655 Reinforced Concrete D-Load Culvert, Storm Drain and Sewer Pipe

C822 Standard Terminology Relating to Concrete Pipe and Related Products

C877 Standard Specification for External Sealing Bands for Concrete Pipe, Manholes, and Precast End Sections

C969 Standard Practice for Infiltration and Exfiltration Acceptance Testing of Installed Precast Concrete Pipe Sewer Lines.

C990 Standard Specification for Joints for Concrete Pipe, Manholes, and Precast Box Sections Using Preformed Flexible Joint Sealants

C1417 Standard Specification for Manufacture of Reinforced Concrete Sewer, Storm Drain, and Culvert Pipe for Direct Design

C1479 Standard Specification for Installation of Precast Concrete Sewer, Storm Drain, and Culvert Pipe Using Standard Installations

C1840 Standard Practice for inspection and acceptance of installed reinforced concrete culvert, storm drain, and storm sewer pipe.

D2487 Standard Practice for Classification of Soils for Engineering Purposes (Unified Soil Classification System)

D2488 Standard Practice for Description and Identification of Soils (Visual-Manual Procedures)

D. OSHA (Occupational Health and Safety Administration)

29 CFR 1926 OSHA Construction Industry Regulations and Standards

### 1.03 RESOURCES

- A. Design
  - 1. ACPA Design Data 9
  - 2. [AASHTO LRFD Bridge Design Specifications](#) - Section 12 Buried Structures and Tunnel Liners
  - 3. [AASHTO LRFD Bridge Design Specifications](#) - Section 3
  - 4. National Cooperative Highway Research Program (NCHRP) – Synthesis 474 Service Life of Culverts
- B. Flotation
  - 1. ACPA Design Data 22 Buoyancy of Concrete Pipe
  - 2. ACPA Concrete Pipe Handbook Sec 5-25 through 5-33 Buoyancy of Concrete Pipe
  - 3. ACPA ePipe #10 Flowable Fill
- C. ADT Limits: Georgia Department of Transportation
- D. Post Installation Inspection
  - 1. Subcommittee on Construction Guide for Pipe Culvert Inspection for New Construction
  - 2. [ASTM C1840](#) Standard Practice for Inspection and Acceptance of Installed Reinforced Concrete Culvert, Storm Drain, and Storm Sewer Pipe.
  - 3. ACPA Sample Specification for Evaluation of Newly Installed Culvert and Storm Drainage Pipe
  - 4. ACPA Post Installation Inspection Methods, Tools, and Reports
  - 5. ACPA Post Installation Evaluation and Repair
- E. Connections to Structures: Texas Department of Transportation Standard Inlet & Manhole Program
- F. Trench Box
  - 1. South Carolina Department of Transportation
  - 2. Washington Department of Transportation
- G. Submittal Data
- H. The contractor shall submit to the Engineer certifications verifying that all pipe and related products supplied meet the applicable specifications and requirements of this standard.
- I. If required by the engineer, pipe product details showing joint and pipe dimensions shall be included in the submittal information.

### 1.04 DEFINITIONS

- A. [Figure 1](#) illustrates the definitions and limits of the terms; foundation, subgrade, bedding, haunch, lower side, initial backfill, pipe zone, embedment zone, backfill or

overflow, invert, crown, springline, top of pipe, and bottom of pipe as used in this Standard.

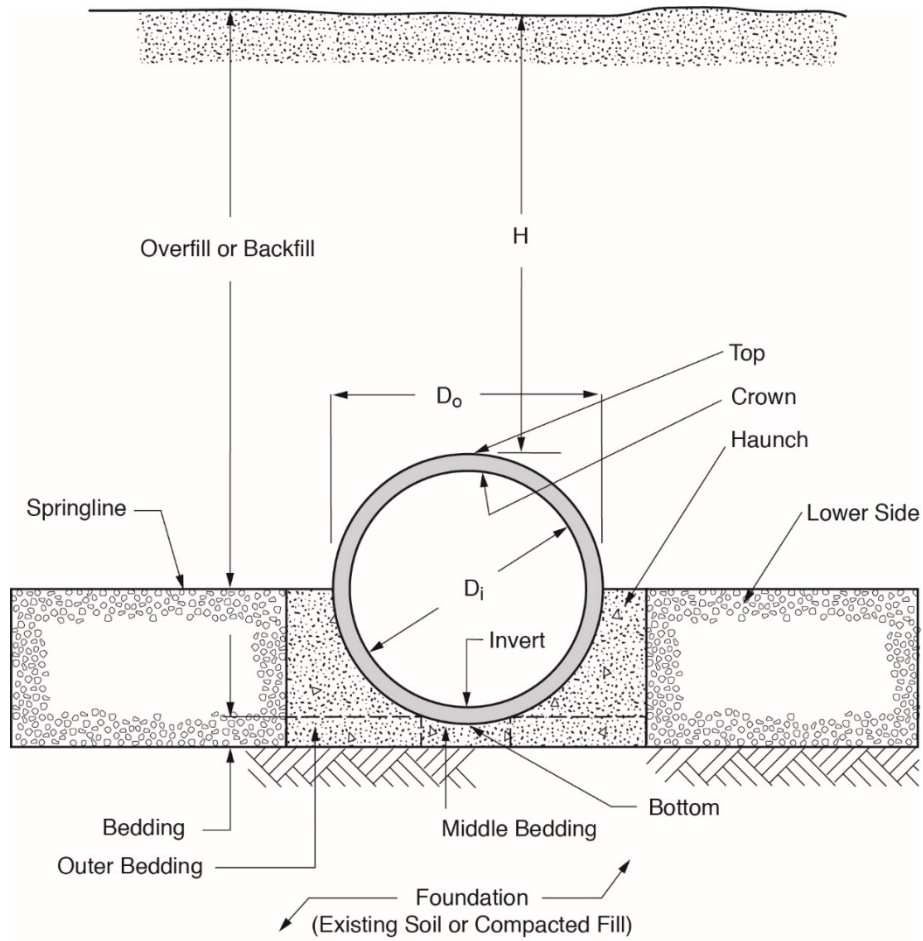

**Figure 1 – Pipe Terminology**

- B. For definitions of terms related to concrete pipe, see [ASTM C822](#).
- C. For terminology related to soil classifications, see [ASTM D2487](#) and [ASTM D2488](#).
- D. For terminology and definition of terms related to structural design, see [AASHTO LRFD Bridge Design Specifications](#).
- E. For terminology and definition terms related to pipe joints, see [AASHTO PP63](#).

## PART 2: DESIGN

### 2.01 GENERAL

- A. Reinforced concrete pipe shall be manufactured in accordance with [ASTM C76](#), [ASTM C655](#), [ASTM C506](#), and [ASTM C507](#), and designed using the indirect method shown in the American Concrete Pipe Association Design Data 9.
- B. As an alternate to the indirect design methods described in Design Data 9, reinforced concrete pipe is permitted to be manufactured in accordance with [ASTM C1417](#), and designed using direct design procedures per [ASCE 15-98](#) Standard Practice for Direct Design of Buried Precast Concrete Pipe Using Standard Installations (SIDD).
- C. For pipe installed below the water table, an analysis checking for possible flotation shall be required.

### 2.02 MATERIALS AND MANUFACTURE

- A. Except as otherwise specified herein, all pipe and appurtenances shall conform to the applicable ASTM or ASCE Standard. Submittal data shall include all materials associated with the pipe product. The strength designation of the pipe shall be as specified on the Drawings or as submitted by the manufacturer.
- B. Circular reinforced concrete culvert and storm sewer pipe shall be manufactured in accordance with [ASTM C76](#), [C655](#), [C1417](#) or special design. Gasketed joints shall be sealed in accordance with [ASTM C443](#). Tongue and groove joints shall be sealed with mortar or preformed flexible sealant per [ASTM C990](#), or other suitable sealant.

Pipe with elliptical reinforcing or quadrant mats shall be clearly marked to indicate the top of the pipe or have a lift hole or lift anchors to ensure proper orientation.

- C. Arch Reinforced concrete culvert and storm sewer pipe shall be manufactured in accordance with [ASTM C506](#). Joints shall be tongue and groove sealed with mortar or preformed flexible sealant per [ASTM C990](#), or other suitable sealant.
- D. Elliptical reinforced concrete elliptical culvert and storm sewer pipe shall be in accordance with [ASTM C507](#). Joints shall be tongue and groove sealed with mortar or preformed flexible sealant per [ASTM C990](#), or other suitable sealant.

### 2.03 HYDRAULICS

- A. When hydraulically sizing the precast reinforced concrete pipe, a Manning's 'n' value of 0.012 shall be used.
- B. Lab values shall not be used due to in-field condition of debris and build-up in the pipe.

### 2.04 FLOTATION

- A. Where water is present in the trench during installation, the contractor shall dewater the trench to maintain line, grade and proper compaction.
- B. When ground water is present after installation, designers shall calculate downward forces acting on the pipe, such as soil, to ensure buoyancy of the pipe is less than the downward forces.

*Note: Coastal area with shallow installation and high water table is a common scenario where flotation could be a concern for concrete pipe.*

- C. Although flowable fills are not generally required for concrete pipe installations, backfill of RCP installations involving a flowable backfill or cement slurry bedding shall be placed with equal volumes of materials in alternating equal lifts to prevent flotation or additional stress on the pipe. The potential for pipe flotation shall be calculated using the density of the flowable fill (approximately 130 lbs/ft<sup>3</sup>)

### 2.05 PIPE JOINT SELECTION

- A. The joint selection process to determine the appropriate joint type shall be done in accordance with [AASHTO PP63](#).
- B. The pipe joint shall consist of a bell (or groove) on one end of a unit of pipe and a spigot (or tongue) on the adjacent end of the joining pipe. Plain joints utilizing

mortar, mastic, external geotextile wraps, and rubber gaskets are all considered soil-tight joints when assembled correctly in the field.

#### C. Soil-tight Joint

1. If water movement through the joint to or from the surrounding soil is acceptable or even desirable, and where the migration of backfill through the joint is not likely, then a soil-tight joint should be selected.
2. Soil-tight joints are specified as a function of opening size (maximum dimension normal to the direction that soil may infiltrate), channel length (length of the path along which the soil may infiltrate), and backfill particle size. If the size of the opening exceeds 1/8 in., the length of the channel must be at least four times the size of the opening. No opening may exceed 1 in.

#### D. Silt-tight Joint

1. If infiltration of backfill material is a concern, then the designer should examine the composition of the backfill material. If there is a high percentage (more than 35%) of soil fines passing the No. 200 sieve, then a silt-tight joint should be selected for most applications.
2. Silt-tight concrete pipe joints that utilize an external joint wrap as the sole method of sealing may include either (a) external sealing bands per [ASTM C877](#) or (b) 12-in. wide geotextile fabric per [M288](#) with an Apparent Opening Size (AOS) > 70.
3. Silt-tight concrete pipe joints that utilize a rubber gasket or mastic filler as the sole method of sealing shall be subjected to a plant proof-of-design hydrostatic test in accordance with [ASTM C443](#), except the maximum hydrostatic test pressure shall not be greater than 2 psi for the straight and deflected position.

#### E. Leak-resistant Joint

1. If limited joint leakage is acceptable, a leak-resistant joint should be selected. A leak-resistant joint limits water leakage at a maximum rate of 200 gallons/inch-diameter/mile/day for the project specified head or pressure.
2. Leak-resistant concrete pipe joints that utilize an external joint wrap as the sole method of sealing may include an external sealing band per [ASTM C877](#) Type 1 or Type 2.
3. Leak-resistant concrete pipe joints that utilize a rubber gasket or mastic filler as the sole method of sealing shall be subjected to a plant proof-of-design hydrostatic test in accordance with [ASTM C443](#) with the maximum hydrostatic test pressures of 10.8 psi in the straight alignment and 10 psi for the deflected alignment.

#### F. Special Joints

1. If limited joint leakage is not acceptable, a special design joint shall be specified. Special design joints include joints requiring additional strength in bending or shear, pull-apart capabilities, or unusual features such as restrained joints in severe slopes, welded, flanged and bolted joints for high pressures, high heads, or velocities.

2. Watertight joints that provide zero leakage for a specified head or pressure application are included in this category.
- G. Pipe joints shall be inspected to ensure dimensions and tolerances are in accordance with the design joint. Pipe, gaskets, wraps, and all other materials used to make and seal the joint shall be inspected for compliance to their respective specifications.
- H. The pipe manufacturer shall perform plant verification tests in accordance with the Plant Test Requirements in [AASHTO PP63](#), when specified.

## 2.06 TRAFFIC LIMITATION SELECTION GUIDELINE FOR CULVERT, SLOPE AND UNDERDRAIN PIPE

**Table 1 - GA DOT ADT Selection Guideline for Culvert, Slope, and Underdrain Pipe**

PIPE TYPE	INSTALLATION TYPE									
	STORM DRAIN							SIDE DRAIN	PERMANENT SLOPE DRAIN	PERFORATED UNDERDRAIN
	TRAVEL BEARING (Inside Roadbed)					NON-TRAVEL BEARING (Outside Roadbed)				
	GRADE < 10%				GRADE > 10%	INTERSTATE	NON-INTERSTATE			
ADT < 1500	ADT ≥ 1500 < 5000	ADT ≥ 5000 < 15,000	ADT ≥ 15,000 & Interstates							
Concrete Pipes Section 843										
Reinforced Concrete AASHTO M 170	YES	YES	YES	YES	NO	YES	YES	YES	NO	NO
Steel Pipes Section 844	Note: See Table 1 for Site Condition Restrictions									
CORRUGATED STEEL ALUMINUM COATED (TYPE 2) AASHTO M 36	YES	YES	NO	NO	NO	NO	YES	YES	YES	YES
CORRUGATED STEEL PLAIN ZINC COATED AASHTO M 36	NO	NO	NO	NO	NO	NO	NO	YES	YES	YES
POLYMER COATED STEEL AASHTO M 245	YES	YES	NO	NO	YES	NO	YES	YES	YES	NO
Aluminum Alloy Pipes Section 840	Note: See Table 1 for Site Condition Restrictions									
CORRUGATED ALUMINUM AASHTO M 196	YES	YES	NO	NO	NO	NO	YES	YES	YES	YES
Thermoplastic Pipes Section 845										
CORRUGATED HDPE AASHTO M 252	NO	NO	NO	NO	NO	NO	NO	NO	NO	YES
CORRUGATED SMOOTH LINED HDPE AASHTO M 294 TYPE "S"	YES	YES	YES	NO	YES	NO	YES	YES	YES	YES
CORRUGATED SMOOTH LINED POLYPROPYLENE AASHTO M 330	YES	YES	YES	NO	YES	NO	YES	YES	YES	YES
PVC CORRUGATED SMOOTH INTERIOR ASTM F 949	YES	YES	YES	NO	YES	NO	YES	YES	YES	YES
PVC PROFILE WALL AASHTO M 304	YES	YES	YES	NO	YES	NO	YES	YES	YES	YES

## 2.07 DESIGN LIFE

- A. For most storm sewers/culvert conditions reinforced concrete pipe has a design life of 100 years. The US Army Corps of Engineers, Engineering Manual gives RCP a 100-year service life. States such as Arizona, Georgia, Kentucky, Connecticut, Alabama give RCP a 100-year service life with pH, chlorides and velocity restrictions. Kansas, Louisiana, Michigan, Minnesota, Missouri, North Dakota,



Oregon, South Dakota, Ontario Canada, define the design life of a concrete pipe between 70-100 years.

B. Elements that may affect RCP service life are:

- Acids
- Sulfates
- Chlorides
- Freeze-thaw and weathering
- Velocity-abrasion

1. The interior and exterior effects of acid on RCP may be considered as shown in [Table 2](#).

**Table 2 - Evaluation Procedures**

Exterior Exposure	Interior Exposure
Accurately determine pH and total acidity	For potential bio-chemical problems in sanitary sewers, determine rate of acid development, if any
Evaluate installation condition from standpoint of the potential acid replenishment	For acid effluents, determine pH, including cyclic variations, as well as continuous or intermittent flow characteristics

2. Sulfates

The Bureau of Reclamation has developed general criteria for evaluating and dealing with the chemical reaction of the concrete with sulfates, shown in [Table 3](#).

**Table 3 - Attack on Concrete Soils and Waters Containing Various Sulfate Concentrations**

Relative Degree of Sulfate Attack	Percent Water-Soluble Sulfate (as SO <sub>4</sub> ) in Soil Samples	PPM Sulfate (as SO <sub>4</sub> ) in Water Samples
Negligible	0.00 to 0.10	0 to 150
Positive <sup>1</sup>	0.10 to 0.20	150 to 1,500
Severe <sup>2</sup>	0.20 to 2.00	1,500 to 10,000
Very Severe <sup>3</sup>	2.00 to more	10,000 or more
<sup>1</sup> Use Type II cement <sup>2</sup> Use Type V cement, or approved Portland-pozzolan cement providing comparable sulfate resistance when in concrete		

<sup>3</sup> Use Type V cement plus approved pozzolan which has been determined by tests to improve sulfate resistance when used in concrete with Type V cement

3. Chlorides
  - a. The most significant aggressive action of chlorides is corrosion of steel in reinforced concrete. Portland cement protects embedded steel against corrosion under conditions that would be highly corrosive to bare steel. This protection is an electro-chemical phenomenon in which the high alkalinity of concrete, normally a pH of 12, passivates the steel. This passivating influence will normally remain effective provided the pH remains above 10. The chloride ion can disrupt the protective mechanism. The greater the chloride ion concentration beyond the critical level, assuming oxygen availability, the more rapid the corrosion will progress.
  - b. For instances where chlorides and sufficient oxygen are both present the severity of chloride attack may be reduced by increasing the concrete cover, using higher concrete quality with low permeability or using a barrier type protective coating.
4. Freeze-thaw and Weathering: This has not been shown to be a concern for concrete pipe.
5. Velocity-abrasion
  - a. At velocities around 40 feet per second, or greater, cavitation effects can be serious unless the surface is smooth and internal offsets at joints are closely controlled. Within the range of velocities up to 40 feet per second, the severity of the abrasion depends on the bead load, which is the quantity of the solids being moved through the pipe by flow velocity.
  - b. Increasing the compressive strength of the concrete along with an increase in the specific hardness of the aggregates used, increases the abrasion resistance.

## 2.08 COLORADO DEPARTMENT OF TRANSPORTATION'S CORROSION AND ABRASION MATRIX

### A. Determine Abrasion Level

1. Abrasion Level 1: This level applies where the conditions are nonabrasive. Nonabrasive conditions exist in areas of no bed load and very low velocities. This is the level assumed for the soil side of drainage pipes. This is also the level assumed for the inverts of cross drains and side drains installed in typically dry drainages.
2. Abrasion Level 2: This level applies where low abrasive conditions exist. Low abrasive conditions exist in areas of minor bed loads of sand and velocities of 5 fps or less.
3. Abrasion Level 3: This level applies where moderately abrasive conditions exist. Moderately abrasive conditions exist in areas of moderate bed loads of sand and gravel and velocities between 5 fps and 15 fps.
4. Abrasion Level 4: This level applies where severely abrasive conditions exist. Severely abrasive conditions exist in areas of heavy bed loads of sand, gravel, and rock and velocities exceeding 15 fps.

### B. Determine Corrosion Level

C. Select Class of Pipe Required on the Project

**Table 4 – Guidelines for Selection of Corrosion Resistance Levels**

**Guidelines for selection of corrosion resistance levels**

CR Level	SOIL			WATER		
	Sulfate	Chloride		Sulfate	Chloride	
	(SO <sub>4</sub> )	(Cl)	pH	(SO <sub>4</sub> )	(Cl)	pH
	% max	% max		ppm (max)	ppm (max)	
*CR 0	0.05	0.05	6.0-8.5	50	50	6.0-8.5
CR 1	0.10	0.10	6.0-8.5	150	150	6.0-8.5
CR 2	0.20	0.20	6.0-8.5	1,500	1,500	6.0-8.5
CR 3	0.50	0.50	6.0-8.5	5,000	5,000	6.0-8.5
CR 4	1.00	1.00	5.0-9.0	7,500	7,500	5.0-9.0
CR 5	2.00	2.00	5.0-9.0	10,000	10,000	5.0-9.0
CR 6	>2.00	>2.00	<5** or >9	>10,000	>10,000	<5** or >9

\*No special corrosion protection recommended when values are within these limits. \*\*Concrete pipe used when the pH of either the soil or water is less than 5 shall be coated in accordance with subsection 706.07. When needed, specify the coating in a special provision or plan note.

**CROSS – DRAINS and SIDE – DRAINS**

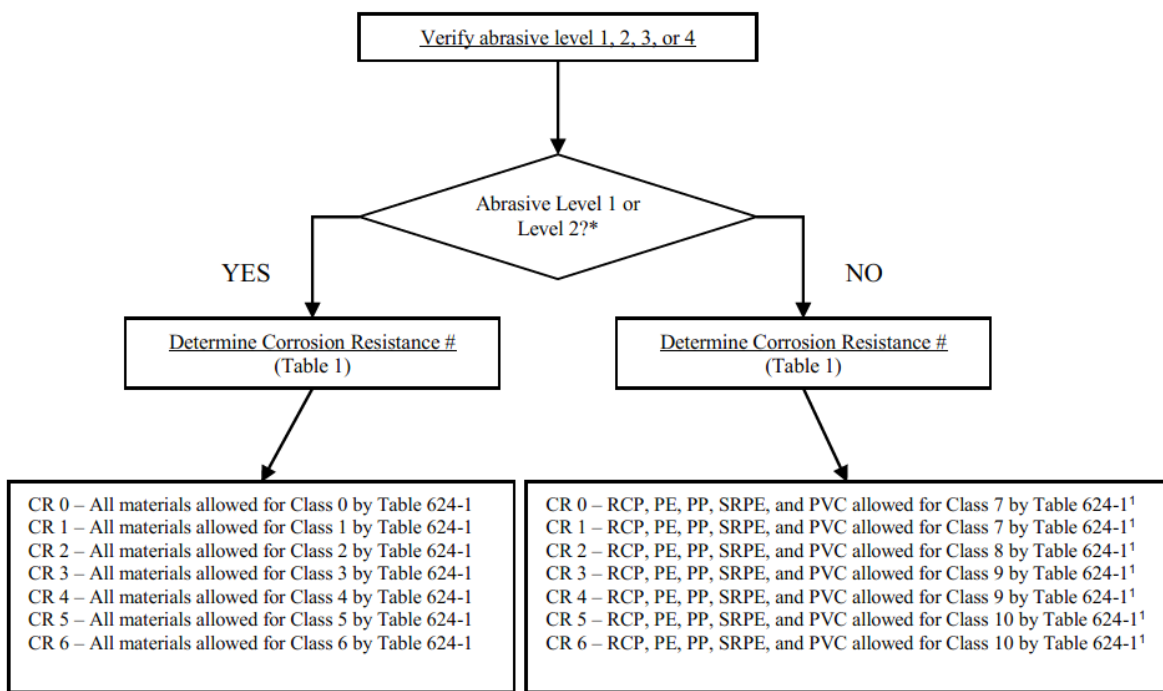

*Note: The class of pipe listed is the result of the Abrasion and Corrosion Level. For example, if you have a Level 3 Abrasion, and Corrosion Level 1, the class of pipe required is Class 7. Proceed to [Section 3.7.4](#) in this Standard.*

**Figure 2 – CDOT Pipe Material Selection Guide**

**D. Select Pipe Allowed on a Project Based on Corrosion and Abrasion**

**Table 5 - Materials Allowed for Class of Pipe**

	Class of Pipe*
--	----------------

Material Allowed**	0	1	2	3	4	5	6 <sup>4</sup>	7	8	9	10 <sup>4</sup>
CSP	Y	N	N	N	N	N	N	N	N	N	N
Bit. Co. CSP	Y	Y <sup>1</sup>	N	N	N	N	N	N	N	N	N
A.F. Bo. CSP	Y	Y	Y	Y	Y	Y	Y	N	N	N	N
CAP	Y	Y <sup>2</sup>	Y <sup>2</sup>	Y <sup>2</sup>	Y <sup>2</sup>	Y	N	N	N	N	N
PCSP - both sides	Y	Y	Y	Y	N	N	N	N	N	N	N
PVC <sup>6</sup>	Y	Y	Y	Y	Y	Y	Y	Y	Y	Y	Y
PE <sup>6</sup>	Y	Y	Y	Y	Y	Y	Y	Y	Y	Y	Y
RCP (SP0) <sup>3,5</sup>	Y	Y	N	N	N	N	N	Y	N	N	N
RCP (SP1) <sup>3,5</sup>	Y	Y	Y	N	N	N	N	Y	Y	N	N
RCP (SP2) <sup>3,5</sup>	Y	Y	Y	Y	Y	N	N	Y	Y	Y	N
RCP (SP3) <sup>3,5</sup>	Y	Y	Y	Y	Y	Y	Y	Y	Y	Y	Y

\*As determined by the Department in accordance with the CDOT Pipe Selection Guide. Determination is based on abrasion and corrosion resistance.

\*\* Y=Yes; N=No.

- <sup>1</sup> Coated Steel Structural Plate Pipe of equal or greater diameter, conforming to Section 510, may be substituted for Bit. Co. CSP at no additional cost to the project.
- <sup>2</sup> Aluminum Alloy Structural Plate Pipe of equal or greater diameter, conforming to Section 510, may be substituted for CAP at no additional cost to the project.
- <sup>3</sup> SP = Class of Sulfate Protection required in accordance with subsection 601.04 as revised for this project. RCP shall be manufactured using the cementitious material required to meet the SP class specified.
- <sup>4</sup> For pipe classes 6 and 10, the RCP shall be coated in accordance with subsection 706.07 when the pH of either the soil or water is less than 5. The Contract will specify when RCP is to be coated.
- <sup>5</sup> Concrete shall have a compressive strength of 4500 psi or greater.

## 2.09 STRUCTURAL DESIGN

- A. This standard practice provides a guidance for both the indirect and direct design methods and it is designed to be used by engineers who are familiar with the concept of soil-pipe interaction and of principals used to perform design of concrete members. Both methods are explained in Section 12.10 (12.10.4.2 for direct design method and 12.10.4.3 for indirect design method) of the [AASHTO LRFD Bridge Design Specifications](#). The indirect method is also explained in the Concrete Pipe Design

Manual, while the direct design is explained in the Concrete Pipe Technology Handbook and [ASCE Standard Practice 15](#).

B. While the indirect and direct design methods are markedly different they are essentially geared towards reaching the same overall objective, the selection of an appropriate balance of pipe structure and soil supporting structure for a given design condition. Regardless of the design method used, the required steps to be followed are:

1. Define design criteria:

- Inside diameter of the pipe.
- Location of the pipe with respect to the ground surface elevation.
- Type of installation.
- Calculate the applied loads which are generated by the earth cover, surcharge, live load, self-weight, and load applied from the fluid transferred by the conduit.

2. Structural Analysis of the Pipe (Indirect Design)

- a. Bedding factors are used to account for the ratio of the load capacity of the pipe under the installed condition and that of the pipe in the three-edge bearing (TEB) test at the plant. The bedding factors account for the effect of the soil-structure interaction, since they are defined based on the ratio of the strength of the pipe under the installed condition of loading and bedding to the strength of the pipe in plant test. The bedding factors can be selected from Section 12.10 of the [AASHTO LRFD Bridge Design Specifications](#) or Chapter 4 of the Concrete Pipe Design Manual.
- b. The strength of the pipe is determined by defining an equivalent three-edge bearing (TEB) load that produces certain performance limits in the pipe. The pipe class strength is specified in terms of an appropriate TEB strength to be supplied in conjunction with a specified installation type. The performance criteria for the TEB strength require pipe to reach test strengths relative to two design limits: service load condition and ultimate strength.

*Note: [ASTM C76](#) defines the limits of the TEB based on the class of the pipe. Design requirements for different pipe classes are offered in [C76](#) for circular culvert, storm drain, and sewer. [ASTM C506](#) and [ASTM C507](#) offer design requirements for arch and elliptical culvert, storm drain, and sewer, respectively.*

3. Structural Analysis of the Pipe (Direct Design): For special designs that do not fall within the parameters of an [ASTM C76 Class Pipe](#), the direct design method may be used. The steps for this are as follows:
  - a. The pipe thickness, concrete strength, steel type and strength, concrete cover, reinforcement arrangement need to be pre-selected.
  - b. Select the load and resistance factors to define moment, thrust, and shear. The load and resistance factors are defined based on Sections 3.4 and 12.5 of [AASHTO LRFD Bridge Design Specifications](#), respectively.
  - c. Determine the amount of reinforcement required based on the tensile yield strength limit state.
  - d. Check if the provided reinforcement at the inside face of the pipe, causes radial tension stresses that are higher than the maximum radial tension strength limit. The reinforcement area based on the tensile yield strength must not exceed the area that produces the limiting radial tension strength.
  - e. Check if the produced compressive strains exceeds the limits. The reinforcement area, based on the tensile yield strength, must not exceed the area that produces limiting compressive strain.
  - f. For pipe with standard diameters and typical wall thicknesses, check if the critical shear force at the wall sections where  $M_{nu}/V_u d = 3.0$  exceeds the shear (diagonal tension) strength limit.
  - g. Check if the service load moments at the crown, invert, or springline, combined with the associated thrusts, cause reinforcement stresses that exceed the service load limit for crack width control.



## **PART 3: PART III: CONSTRUCTION**

### 3.01 ACCEPTANCE UPON DELIVERY

- A. Except as modified or supplemented herein, all precast reinforced concrete pipe shall conform to the applicable requirements of [AASHTO R73](#).
- B. Any defective precast concrete pipe may be repaired per [AASHTO R73](#), Section 5 "Repairable Defects In Precast Concrete Products".
- C. All products should be accompanied by material certification by manufacturer which shall include a written statement certifying that the steel used in the production of all

product delivered to the job site complies with all provisions of the "Buy America Act".

- D. Pipe shall be subject to rejection in accordance with [AASHTO R73](#), Section 6, "Rejectable Defects in Precast Concrete Products".

### 3.02 INSPECTION BEFORE INSTALLATION

- A. All products are subject to final visual inspection for shipping and handling damage, fit and other visual defects and disposition to the project site in accordance with [AASHTO R73](#).
- B. Verify concrete pipe acceptance report is current and covers manufacturing plant, pipe diameter, class of pipe, ASTM Standard the pipe was manufactured to, date the pipe was manufactured.

### 3.03 QUALITY ASSURANCE

- A. Post-Installation Performance Requirements for Joints
  1. The standard procedures for verifying performance of the pipe joint in the field shall be done in accordance with the Field Test Requirements in [AASHTO PP63](#), when specified.
  2. Soil-tight Joint: Installed pipe joints shall have a visual or video inspection in the field to ensure compliance to the project specifications. Open joints or joints that are flowing particles larger than those retained on a No. 200 sieve shall be repaired or replaced as necessary.
  3. Silt-tight Joint: Installed pipe joints shall have a visual or video inspection in the field to ensure compliance to the project specifications. Open joints or joints showing sediment as a result of flowing infiltration or exfiltration of particles smaller than those passing the No. 200 sieve shall be repaired or replaced as necessary.
  4. Leak-resistant Joint: Installed pipe joints shall have a visual or video inspection in the field to ensure compliance to the project specifications. Open joints or joints showing sediment as a result of measurable infiltration or exfiltration shall be repaired or replaced as necessary. Leak-resistant concrete pipe joints shall be tested to the performance requirements in accordance with [ASTM C969](#).
    - a. Infiltration Testing
      - 1) The allowable leakage limit is 200 gallons/in.-diameter/mile/day when the average head on the test section is 6 ft or less.
      - 2) When the average head on the test section is greater than 6 ft, the allowable leakage shall be increased in proportion to the ratio of the square root of the average groundwater head to the square root of the base head of 6 ft.
    - b. Exfiltration Testing
      - 1) The allowable leakage limit is 200 gallons/in.-diameter/mile/day when the average head on the test section is 3 ft or less.

- 2) When the average head on the test section is greater than 3 ft, the allowable leakage shall be multiplied by the ratio of the square root of the average test head and the square root of the base head of 3 ft.
- c. For either infiltration or exfiltration testing, manholes shall be tested separately and independently or with the pipeline with the allowance of 0.1 gal/ft of MH diameter/ft of head/hour. If building or house leads are connected to the main line being tested, allowance shall be made for permissible leakage in such leads.

### 3.04 PIPE LAYING

- A. Care shall be taken in loading, transporting, and unloading to prevent damage to the pipe.
- B. Preparation of bedding and backfill shall be as specified on the Drawings and per the requirements of the American Concrete Pipe Association's Design Data 9 or [ASTM C1479](#). Pipe shall be laid with uniform bearing under the barrel of the pipe. For projecting bell pipe, bell holes shall be provided.
- C. Pipe shall not be laterally displaced by pipe embedment material installed as provided in the Drawings. No pipe shall be laid in unsuitable bedding conditions such as, but not limited to, water in the trench or hard rock. Pipe shall be laid with bell ends facing the direction of laying except when making closures.
- D. When the design requires special bedding conditions for culverts or storm drains, an excavation diagram will be shown on the plans. Do not exceed these limits of excavation. The length of trench excavation in advance of pipe laying shall be kept to a minimum.
- E. All material excavated from trenches and piled adjacent to the trench shall be maintained so that the toe of the slope is at least 2 feet from the edge of the trench. It shall be piled to cause a minimum of inconvenience to public travel, and provision shall be made for merging traffic where necessary. Free access shall be provided to all fire hydrants, water valves, and meters; and clearance shall be left to enable free flow of storm water in gutters, conduits, or natural watercourses.
- F. Rubber gaskets shall be installed in strict conformance with the pipe manufacturer's recommendations.
- G. Pipe shall be laid to line and grade as shown on the plans. Adjustments in grade by exerting force on the barrel of the pipe with excavating equipment or by lifting and dropping the pipe shall be prohibited. If the installed pipe section is not on grade, the pipe section shall be completely un-joined, the grade corrected, and the pipe then

rejoined. Curves may be formed using fittings, specials, beveled end pipe or unsymmetrical joint closure of straight pipe.

### 3.05 SOIL COVER

#### A. Construction Soil Cover

1. If the passage of construction equipment over an installed culvert is necessary during project construction, compacted overfill in the form of a ramp shall be constructed to a minimum elevation of 3.0 ft over the top of the culvert or to a height such that the equipment loads on the culvert do not exceed the culvert design strength.
2. In an embankment installation, the overfill shall extend a minimum of one culvert diameter width or 3.0 ft whichever is greater, beyond each side of the culvert to prevent possible lateral displacement of the culvert.
3. If a large volume of construction traffic must cross an installed culvert, the point of crossing shall be changed occasionally to minimize the possibility of lateral displacement.

B. Minimum Soil Cover: The minimum soil cover for final backfill of an installed culvert shall not be less than 1.0 ft over the top of the culvert regardless of pavement type, unless a special design is performed.

#### C. Maximum Soil Cover

1. The maximum soil cover for final backfill of an installed culvert shall not be greater than 40.0 ft over the top of the culvert for standard culverts and installations depending on diameter of the culvert and installation type. When greater soil cover is expected, a special design is required and should be designed and installed per the manufacturer's recommendations.
2. For soil cover specifics based on diameter of the culvert, see the latest version of the LRFD Fill Height Tables provided by the American Concrete Pipe Association, which is based on the latest version of the [AASHTO LRFD Bridge Design Specifications](#).

### 3.06 TRENCH BOXES

- A. If trench boxes are required for trenches less than 20 feet deep, follow [OSHA 29 CFR 1926.652](#), trench box manufacturer, and industry standards.
- B. When trench boxes are required for trenches exceeding 20 feet deep, the Contractor shall submit to the Owner designs, plans, and supporting calculations for protective systems and shoring equipment sealed by a Professional Engineer. The submittal shall include the manufacturer's certified trench box plans with depth restrictions, and the serial number for field verification of the trench box.
- C. When trench boxes are moved, the previously placed pipe and structural backfill shall not be disturbed. The trench box shall be moved in increments during the installation process to permit placement and compaction of structural backfill material for the full width of the trench while continuing to follow Subpart P of [OSHA 29 CFR 1926](#).

Voids that are created by movement of the trench box shall be filled and compacted with structural backfill.

### 3.07 CONNECTIONS TO STRUCTURES

- A. A pipe may be connected to either round or rectangular shaped structures. The diameter of a penetration into a structure must consider the outside diameter of the pipe and clearance for placement. The placement clearance is 2 in. maximum, 1 in. minimum around the circumference of the pipe (4 in. total maximum, 2 in. total minimum). When using a flexible connector, allow for placement clearance per flexible connector manufacturer's recommendation.
- B. Use of thin-wall panels in structures are permitted provided the panels are not connected to a structure floor, or within 6 in. of a joint. Cut or cast holes are permitted

provided they do not extend into the floor or less than the wall thickness of the structure from an adjacent hole or the joints above or below.

- C. Penetrations must enter a round base at the centerline of the structure. Penetrations are permitted to enter a rectangular structure laterally-offset from center when needed, such as when pipes on opposite walls are not co-linear.
- D. Mortar connections as shown in [Figure 2](#).
  - 1. The pipe shall be positioned in the center of the opening and set to proper grade. Pipe ends shall be placed flush with the inside surface of the structure.
  - 2. Voids shall be completely filled between the precast structure and the connecting RCP with non-shrink or expansive, quick setting grout. Surfaces to which the grout is applied shall be clean and saturated surface dry with potable water.
  - 3. Grouted joints shall be adequately cured immediately after installation and for a minimum of 24 hours thereafter. Moisture shall be maintained within the grout during curing. Finish shall be in a neat, workmanlike manner. Bricks, masonry blocks, native stone or similar materials should not be used in conjunction with mortar or grout to fill voids. Proper curing time shall be allowed prior to backfilling. Voids larger than 1 ft. in width, depth or height shall not be permitted.
- E. Flexible connectors shall be used only where indicated. Flexible connectors shall only be used on cored or precisely cast holes within tolerances dictated by the flexible connector manufacturer's recommendations.
  - 1. When using flexible connectors, the inside surface of the flexible connector shall be cleaned prior to insertion of the RCP through the center of the connector.
  - 2. The end of the RCP shall be flush with the inside surface of the structure wall.
  - 3. Clamps shall be installed and tightened to required torque per manufacturer's recommendations.
  - 4. Grouting over flexible connectors is not permitted.

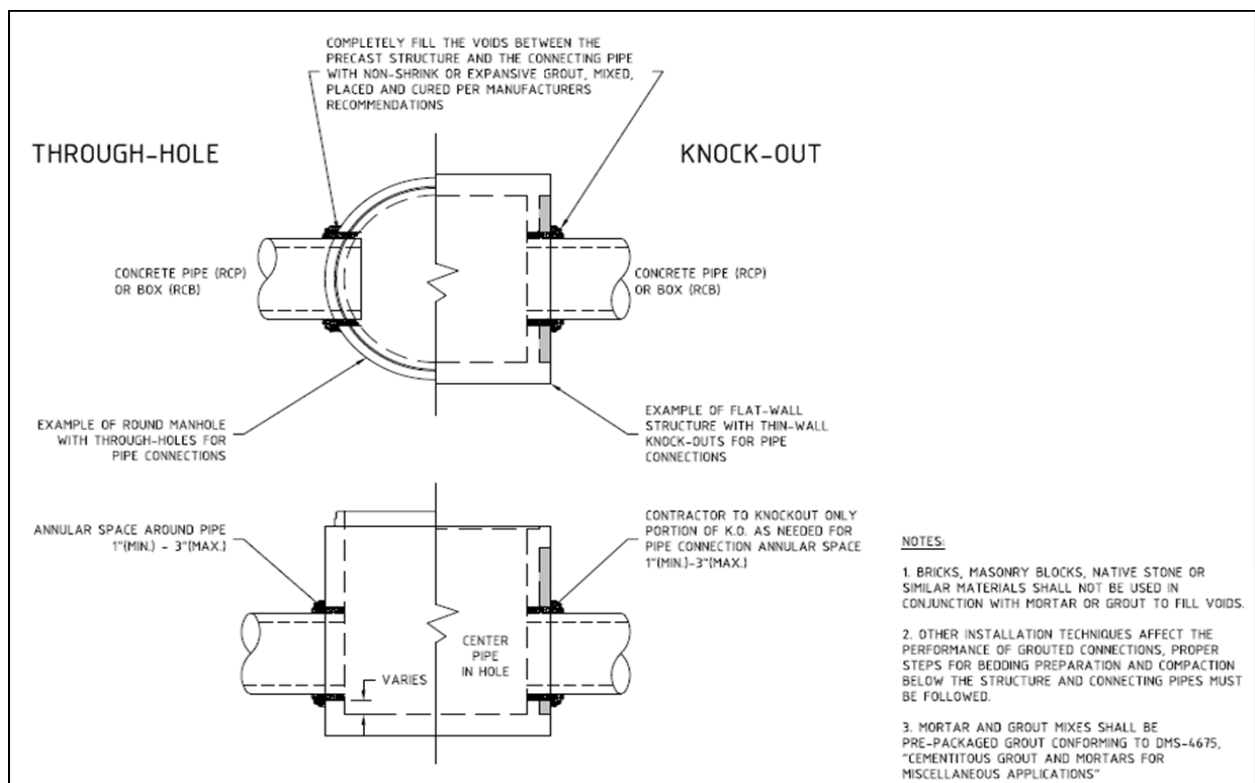

**Figure 3 - Connection to Structures**

### 3.08 POST INSTALLATION INSPECTION

- Post Installation Inspection shall be performed on all pipelines in accordance with the Subcommittee on Construction Guide for Pipe Culvert Inspection for New Construction unless noted otherwise here within.
- The Inspector shall physically inspect all storm sewers larger than 30 inches in diameter after installation. A closed-circuit camera may be used in pipes smaller than 30 inches.
- Pipes shall be inspected no sooner than 30 days after backfilling and prior to paving, or final grade.
- Inspection criteria shall be based on [ASTM C1840](#) Standard Practice for inspection and acceptance of installed reinforced concrete culvert, storm drain, and storm sewer pipe.
- Based on the evaluation, the Engineer shall allow the pipe to remain in place if remediations are made according to an approved remediation plan submitted in writing to the Owner by the Engineer. The Contractor shall have full understanding of the remediation process prescribed and how to perform the remediation.