

Standardized Test Practice

Student Edition

blue.msscience.com



Glencoe

New York, New York Columbus, Ohio Chicago, Illinois Peoria, Illinois Woodland Hills, California



The McGraw-Hill Companies

Copyright © by The McGraw-Hill Companies, Inc. All rights reserved. Except as permitted under the United States Copyright Act, no part of this publication may be reproduced or distributed in any form or by any means, or stored in a database retrieval system, without prior written permission of the publisher.

Send all inquiries to:
Glencoe/McGraw-Hill
8787 Orion Place
Columbus, OH 43240-4027

ISBN 0-07-867161-2

Printed in the United States of America.

1 2 3 4 5 6 7 8 9 10 071 09 08 07 06 05 04

CONTENTS

Introduction	4
Chapter 1: The Nature of Science	7
Chapter 2: Traits and How They Change	11
Chapter 3: Interactions of Human Systems	15
Chapter 4: Interactions of Life	19
Chapter 5: The Nonliving Environment	23
Chapter 6: Ecosystems.	27
Chapter 7: Plate Tectonics	31
Chapter 8: Earthquakes and Volcanoes	35
Chapter 9: Clues to Earth's Past	39
Chapter 10: Geologic Time	43
Chapter 11: The Sun-Earth-Moon System	47
Chapter 12: The Solar System	51
Chapter 13: Stars and Galaxies.	55
Chapter 14: Inside the Atom	59
Chapter 15: The Periodic Table	63
Chapter 16: Atomic Structure and Chemical Bonds.	67
Chapter 17: Chemical Reactions.	71
Chapter 18: Motion and Momentum	75
Chapter 19: Force and Newton's Laws	79
Chapter 20: Work and Simple Machines.	83
Chapter 21: Thermal Energy	87
Chapter 22: Electricity	91
Chapter 23: Magnetism.	95
Chapter 24: Waves, Sound, and Light	99

Introduction

What is in this book?

Welcome to the Student Edition of *Mastering Standardized Tests for Glencoe Science Level Blue*.

There are three distinct sections in this workbook:

- **Introduction: *Methods***

This introduction provides you with methods to tackle test questions. Using the methods in this introduction, you will learn how to use the process of elimination, how to identify important information in the tests' graphs, charts, and tables, as well as other skills that can help you succeed on tests. Carefully study the methods in this introduction before you begin the test questions in this workbook.

This workbook was written to accompany your textbook. For every chapter in your textbook, there are two types of tests in this workbook.

- **Chapter Test: *Content Mastery***

For every chapter in *Glencoe Science Level Blue*, this workbook contains a Chapter Test. Each Chapter Test is made up of multiple-choice questions designed to assess your knowledge and understanding of the material in the corresponding chapter of the textbook.

- **Standardized Test Practice: *Test Preparation***

For every chapter in *Glencoe Science Level Blue*, this workbook contains a corresponding Standardized Test Practice. The questions in this section are designed to prepare you for national science tests such as the TerraNova, the Iowa Tests of Basic Skills (ITBS), and the Stanford Achievement Test, Ninth Edition (SAT-9). The format of the questions found in these practice tests is very similar to the format of the questions found in the actual national science tests.

Task Regimen

A unique four-part **Task Regimen** and helpful **Test-Taking Tips** designed to maximize the benefits of using this workbook are presented in this section. Each of the four tasks is designed to help you identify challenges and improve your performance.

Each task has an assignment for you to do on your own at home and one to do in class. Often the homework and the in-class activities will be coordinated, so it is important that you concentrate on both equally.

TASK

At-Home Assignment

In-Class Assignment

TASK 1

Using an answer key from the teacher, locate and review any questions you missed. Place a question mark beside any question you cannot figure out and bring it to class for discussion.

The teacher administers the test in a realistic test-taking environment.

TASK 2

For each question you missed, find the pages in the textbook that cover the material and explain what specific information was needed to answer the question correctly. If you cannot find any helpful information in the textbook, write out three questions about the test question that you did not understand.

Work in a group to discuss any confusing questions and content areas. Then work through the confusing questions together.

TASK 3

For every incorrect question, go through each answer choice and explain why it is correct or incorrect. Include any tips or hints you noticed that helped you eliminate choices. Place a question mark beside any question you cannot figure out and bring it to class for discussion.

Your teacher will lead a discussion for each question. Share your ideas and observations with the class. Keep notes of the discussion to help your review.

TASK 4

Your teacher will provide you with a list of questions to work on. For each question, make observations and write down all of the information given in the test in the form of a graphic, a passage, or otherwise. Write the information directly onto the test.

Work in a group to discuss each question. Make sure to note the location in the textbook where helpful information was found.

Test-Taking Tips

Test-Taking Tips for Before the Test:

1. Be sure to get plenty of sleep the week before the test. A healthy amount of sleep is 8–9 hours every night.
2. The night before the test, try to do something relaxing but stimulating, such as playing a board game, exercising, or reading an enjoyable book. Cramming the night before the test often can hamper your memory and make you tired.
3. The morning of the test, eat a healthy breakfast with fresh foods that are high in protein and carbohydrates.
4. The morning of the test, clear your mind of any outside distractions so that you will be better able to focus on the test. If breaks are given during the test, use that time to relax and clear your mind.

Test-Taking Tips for During the Test:

1. Listen to and read all directions.
2. Be sure you understand the question before reading the answer choices. Then, make sure to read and consider **every** answer choice.
3. Remember to carefully consider all the information presented in the test’s graphics.
4. If the test is timed, be sure to pace yourself.
5. Always choose an answer. By eliminating as many incorrect choices as possible, you will have a good chance at guessing correctly and obtaining more points.

DIRECTIONS

Read each question and choose the best answer. Then fill in the correct answer on your answer document.

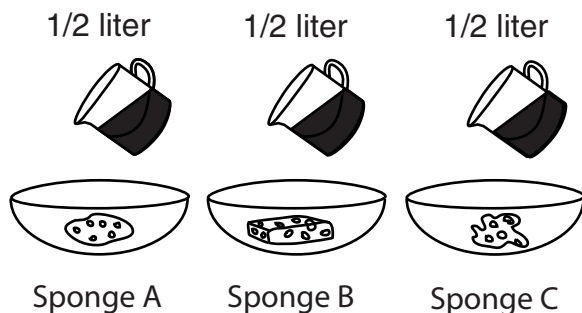

1. Which of these questions would most likely be answered by this experimental setup?
 - a. How does room temperature affect water?
 - b. Which sponge is the most absorbent?
 - c. How fast will the water evaporate?
 - d. Which sponge cleans the best?

2. In an experiment designed to determine if a specific brand of cat food is causing cats to meow excessively, it would be best to _____.
 - f. keep feeding cats with the specific brand of cat food and record the results
 - g. mix together the specific brand of cat food with another brand of food and feed to cats
 - h. let some of the cats drink water with the specific brand of food
 - j. feed some cats with the specific brand of cat food and other cats with another brand

3. All of these are examples of ways in which models can help scientists EXCEPT _____.
 - a. communicating observations and ideas
 - b. saving time, money, equipment, and lives
 - c. predicting exactly what will happen
 - d. predicting possible outcomes

WARNING:

Goggles and Aprons Must
Be Worn at All Times

4. This sign was found at the entrance of a chemistry laboratory. It is an important sign because _____.
 - f. goggles help chemists see better
 - g. chemicals can seriously damage eyes and skin
 - h. accidents rarely happen in laboratories
 - j. chemists will be fined if they do not obey the rules

5. Trina wanted to find out which of her rubber balls can bounce the highest. She took the first ball and dropped it onto the cement sidewalk. She then dropped the second ball from the same height onto the grass. She recorded how high each ball bounced. Her experiment could be improved by _____.
- a. measuring the time it takes for each ball to reach its maximum height
 - b. bouncing both balls on one of the surfaces
 - c. dropping the second ball from a higher height
 - d. bouncing the ball on the grass two times
6. All of these are branches of science EXCEPT _____.
- f. life
 - g. earth
 - h. physical
 - j. abstract
7. A protein bar claims on its packaging that it is all natural. Which of these sources might be the most helpful in determining whether this claim is entirely true?
- a. Television advertisements
 - b. The taste of the bar
 - c. The list of ingredients
 - d. The manager of a grocery store
8. Scientists now believe that life may have existed on Mars at one time. This is an example of _____.
- f. a scientific law
 - g. a scientific certainty
 - h. a scientific theory
 - j. a scientific question



DIRECTIONS

Read each question. Then, on your answer sheet, mark the answer choice that you think is best.

- 1** A possible explanation for scientific data or observations is called a
- A** hypothesis
 - B** control
 - C** variable
 - D** constant
- 2** Which of the following is not a benefit of scientifically obtained evidence?
- F** Repeatability
 - G** Believability
 - H** Ability to evaluate relative merit
 - J** Permanence
- 3** Which of these is a limitation of using models in science?
- A** Delaying the outcome of an experiment
 - B** Hindering experimenters from testing their hypotheses
 - C** Basing models on an incomplete or inaccurate observation
 - D** Inhibiting the ability of scientists to communicate with each other
- 4** Experimental results are compared against the results of controls. Controls improve an experiment by
- F** ensuring that the experiment tests only one variable
 - G** allowing for the experiment to test as many variables as possible
 - H** making sure everything in the experiment remains constant
 - J** guaranteeing that the experimental outcome verifies the hypothesis

- 5** In an experiment, a model can help a scientist
- A** create a hypothesis
 - B** make the experimental setup match reality as closely as possible
 - C** test a situation that is otherwise too complex to observe
 - D** draw a conclusion from experimental results

- 6** Which of these is a potential problem in science?
- F** Bias
 - G** Repeatability
 - H** Observation
 - J** Communication

- 7** Which statement provides the best description of a theory?
- A** A theory is an explanation that is supported by scientific observations.
 - B** A theory is a factual and absolute depiction of reality.
 - C** Theories are easily disproven.
 - D** A theory is a never-changing model of the universe and everything in it.

- 8** Which of these is not an important laboratory consideration?
- F** Safety
 - G** Accuracy
 - H** Certainty
 - J** Precision

Directions: Read Number 9 below. Then, on the lines that follow, write your answer in complete sentences.

- 9** There are three branches of science: life, Earth, and physical. Explain the similarities and differences among these three branches of science.



DIRECTIONS

Read each question and choose the best answer. Then fill in the correct answer on your answer document.

1. Which of the following graphs would best show that a certain plant grows taller in higher temperatures?

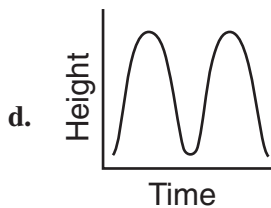
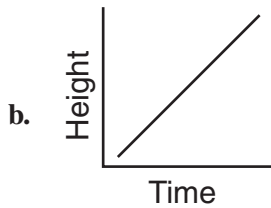
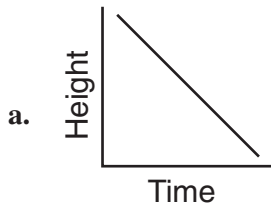
**Flower Colors**

Color	Number of Flowers
White	24
Pink	51
Red	25

2. Which of the graphs best represents these data?

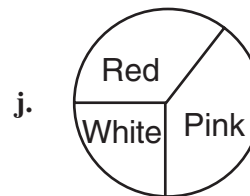
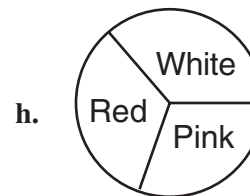
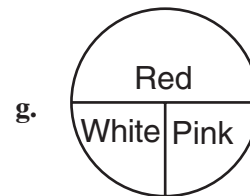
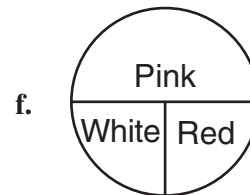

3. On a small island in the Pacific Ocean, the main food supply for birds is a kind of insect that burrows deeply into trees. The birds must reach into small holes in the trees to find the insects. Which trait would be most helpful to a bird on this island?

- a. A short, wide beak
- b. A long, narrow beak
- c. Large wings
- d. Small wings

4. For a certain kind of bird, the allele for long beaks (L) is dominant over the allele for short beaks (l). Which of the following genotypes will produce a bird with a short beak?

- f. Ll
- g. lL
- h. ll
- j. LL

5. Which of the following traits would most likely be found in an animal that hunts other animals for food?

- a. Short legs
- b. Short fur
- c. Long nose
- d. Sharp teeth

6. Dale thought that plants growing near the road grew taller than plants growing far away from the road. Which of the following would be the best way to test this hypothesis?

- f. Measure the rainfall in the area where the plants are growing.
- g. Count the number of cars that pass along the road each day.
- h. Compare the heights of plants near the road and plants away from the road.
- j. Count the hours of sunlight received by the plants.

	B	b
B	?	Bb
b	Bb	bb

7. In humans, the allele for brown eyes (B) is dominant over the allele for blue eyes (b). Which of these genotypes will complete this Punnett square?

- a. BB
- b. Bb
- c. bB
- d. bb

8. In a certain kind of fish, the allele for wide fins (W) is dominant over the allele for narrow fins (w). Which of the following genotypes will produce a fish with wide fins?

- f. WW and ww
- g. WW and Ww
- h. Ww and ww
- j. ww and wW



DIRECTIONS

Read the passage. Then read each question that follows the passage. Decide which is the best answer to each question. Mark the letter for that answer.

A Disappearing Bird

The kakapo was not always one of the rarest types of parrot in the world. New Zealand was once teeming with these awkward, flightless fowls. Several thousand years ago, the kakapo enjoyed an environment that was practically without predators. Sadly, the kakapo's carefree lifestyle ended when humans began to populate the area.

An Unusual Bird

Although the kakapo is a member of the parrot family, it has few similarities to the parrots with which most people are familiar. For one thing, the kakapo is unusually large. An adult kakapo can weigh as much as eight pounds, whereas the average parrot weighs approximately one pound. In addition, the kakapo looks more like a colorful owl than a parrot. It has a rounded head with a ring of feathers around its neck that resemble whiskers. The kakapo's body is bulky and covered with dark green, black, and yellow feathers.

Aside from its appearance, the kakapo has two other traits that set it apart from other parrots. First, the kakapo is the world's only nocturnal parrot—it sleeps during the day and hunts at night. Second, the kakapo has sizable wings but, unlike other parrots, is not able to fly. Instead, it walks or runs from place to place on its strong legs. It is common for a kakapo to walk up to several miles each night in search of food.

The Kakapo in Danger

Scientists believe that the kakapo was once able to fly. However, after living for thousands of years in an area without natural predators, the kakapo had no reason to use its wings for escape. Over time, the kakapo became a bird that was quite content to stroll leisurely along the ground and climb the occasional tree in search of food.

Unfortunately, the kakapo's inability to fly

became a problem when humans moved into the area. When the first Polynesian settlers arrived, they hunted the kakapo for food and cut down many of the forests in which the kakapo lived. Kakapo skins and feathers were highly valued among the settlers, who used them to make clothing and bedding. To make matters worse, the settlers brought along dangerous animals that preyed upon the defenseless kakapo.

The discovery of the kakapo by Europeans in the mid 1800s was the final blow to the kakapo population. The Europeans were so impressed by the unusual bird that even more kakapos were killed for the sole purpose of displaying stuffed specimens in museums. Within a few hundred years, the kakapo population was in grave danger of extinction.

Saving the Kakapo

After years of thoughtless kakapo hunting, people began to fear the bird's extinction. In the early 1950s, a conservation group began the first effort to save the kakapo from its seemingly inevitable fate. For years, conservationists tracked and captured all of the kakapos they could find. The birds were transported to island sanctuaries where they would be safe. In the first twenty years of searching, fewer than ten kakapos were found.

In the twenty-first century, the kakapo conservation effort is still going strong. Thanks to the diligence of some very dedicated people, there are over sixty kakapos in existence today! Conservationists continue to study the bird's habits in hopes of finding new ways to increase the kakapo population. With continued success, conservationists will undo some of the damage that humans have inflicted upon the kakapo population throughout history.

- 1** Information in the passage suggests that the protected kakapo population is —
- A** dwindling
 - B** unhealthy
 - C** growing
 - D** fearful
- 2** Which of these happened first in the passage?
- F** Polynesians moved to New Zealand.
 - G** Kakapos were taken to a sanctuary.
 - H** The kakapo lost its ability to fly.
 - J** Europeans discovered the kakapo.
- 3** What is the main idea of the third paragraph?
- A** The kakapo's habits make it very different from other parrots.
 - B** The kakapo is awake at night and sleeps during the day.
 - C** Instead of using its wings, the kakapo walks from place to place.
 - D** The kakapo has sizable wings and strong legs.
- 4** Which of these is the best summary of this passage?
- F** Humans introduced dangerous animals to New Zealand that preyed upon the defenseless kakapo.
 - G** A once-abundant kakapo population is now in danger of extinction because of human carelessness.
 - H** Conservationists continue to study the bird's habits in hopes of finding new ways to help the kakapo.
 - J** Although the kakapo is a parrot, it has few similarities to the parrots with which most people are familiar.
- 5** In this passage, the word diligence means —
- A** reassurance
 - B** close attention
 - C** funding
 - D** hard work
- 6** Based on information from the passage, the reader can conclude that many Europeans in the 1800s —
- F** worked to protect the kakapo population
 - G** were more interested in other kinds of parrots
 - H** believed the kakapo could fly like other parrots
 - J** were not concerned about animal extinction
- 7** Early settlers probably thought the kakapo population was —
- A** dangerous
 - B** unlimited
 - C** useless
 - D** annoying



DIRECTIONS

Read each question and choose the best answer. Then fill in the correct answer on your answer document.

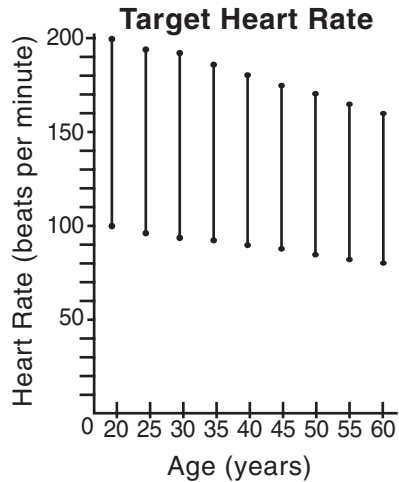

1. According to these data, what is the maximum heart rate for a thirty-year-old person?
 - a. 200
 - b. 190
 - c. 175
 - d. 170

2. Which factor would have the **LEAST** effect on an experiment testing a person's lung function?
 - f. The length of time a person can hold his or her breath
 - g. The amount of air a person can exhale
 - h. The person's breathing rate at rest
 - j. The person's heart rate at rest

3. All of the following are important organic compounds used by the body **EXCEPT** —
 - a. carbohydrates
 - b. lipids
 - c. proteins
 - d. binary salts

MOUTH STOMACH INTESTINE

4. In which of the following human systems do the above words belong?
 - f. Nervous system
 - g. Respiratory system
 - h. Digestive system
 - j. Skeletal system

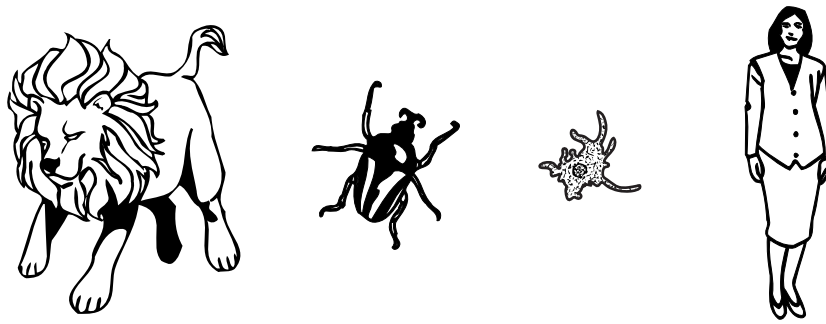

5. What characteristic do these organisms have in common
- They produce milk for their young.
 - They sense the world around them using an advanced nervous system.
 - They walk on two legs.
 - Their digestive systems convert food into small molecules that can be used for energy
-
6. Which of the following is the correct order for the levels of organization of the human body, from smallest to largest?
- Cell \longrightarrow Tissue \longrightarrow Organ \longrightarrow Organ System
 - Tissue \longrightarrow Organ System \longrightarrow Organ \longrightarrow Cell
 - Organ \longrightarrow Cell Tissue \longrightarrow Organ System
 - Organ System \longrightarrow Organ \longrightarrow Tissue \longrightarrow Cell



DIRECTIONS

Read each question and choose the best answer. Then mark the letter for the answer you have chosen. If a correct answer is not here, mark the letter for “Not here.”

- 1** Small intestines are about 6 meters long. What is this length expressed in *centimeters*?

A 0.6 cm
B 6 cm
C 60 cm
D 600 cm

- 2** Mr. Hernandez’s class took a science quiz. Four students scored a perfect 10 on the quiz, three scored a 9, six scored an 8, five scored a 7, and two scored a 5. What was the average quiz score?

F 10
G 9
H 8
J 7

- 3** Chu bought 6 high-carbohydrate bars for \$12.48. At this price, how much would Chu have to spend to buy three more bars?

A \$2.08
B \$4.19
C \$6.24
D \$12.48

- 4** Martin is studying the length of time that different swimmers can hold each breath as they swim across a pool, where b is the length of time for a single breath. He has a group of swimmers swim across a pool. He times each of them and counts the number of times they come up for breath. One swimmer starts 6 seconds late by mistake, takes 9 breaths overall, and has a total time of 60 seconds. If Martin uses the equation $9b + 6 = 60$, what is b ?

F 9
G 7
H 6
J 3

Duration of Holding Breath

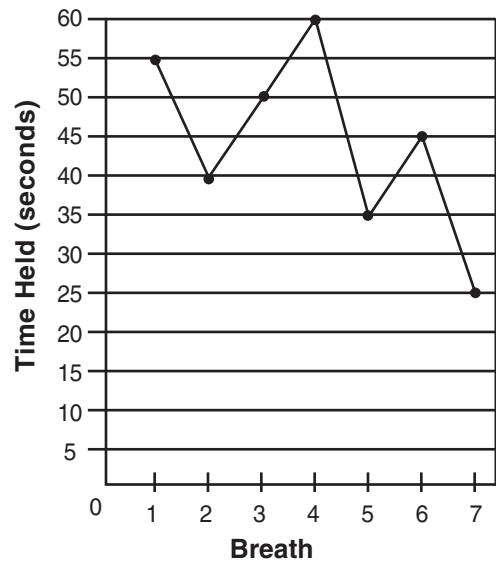

- 5** The graph shows seven different efforts by Mary to hold her breath. How much longer did she hold her breath on her best effort than on her worst?

A 55 seconds
B 45 seconds
C 35 seconds
D 25 seconds

- 6** On average, 9 out of every 10 chemical compounds is classified as an organic compound. If Ms. Jones's class has 40 different samples of chemical compounds, which is the best estimate of the number of compounds that will be organic?

F 9
G 10
H 36
J 40

Please note that items 7–9 have five answer choices.

- 7** A science class was studying heart rates. After a brief jog, 5 of the class's 21 students had heart rates below 150 beats per minute. Which expression could be used to find the percent of students with heart rates below 150 beats per minute?

A $\frac{(500)(100)}{(21 - 5)}$
B $\frac{(5)(100)}{(21)}$
C $\frac{(21 - 5)(100)}{(5)}$
D $\frac{(21 - 5)(100)}{(21)}$
E $\frac{(21)(100)}{(5)}$

- 8** Tony has been working as a science tutor. Last week, he spent 3.2 hours tutoring students about the nervous system and three times as long tutoring students about the skeletal system. Which equation could be used to find h , the total number of hours he spent tutoring last week?

F $h = 3(3.2)$
G $h = 3.2 + 3(3.2)$
H $h = 3.2 + 3.2 + 3$
J $h = 3 \times 3 \times 3.2$
K $h = 3.2 + 3$

- 9** A science teacher is ordering classroom supplies. The teacher orders a poster of the nervous system for \$5.99, a plastic skeleton for \$35.97, and a CD-ROM about the respiratory system for \$20.49. How much did the teacher spend altogether?

A \$50.95
B \$52.45
C \$60.95
D \$62.45
E Not here



DIRECTIONS

Choose the best answer choice for each of the following questions.

Year	Number of Gila Woodpeckers
1985	250
1986	270
1987	285
1988	310
1989	260

1. The chart shows the number of Gila woodpeckers found in Wright County. Which of these graphs best represents these data?

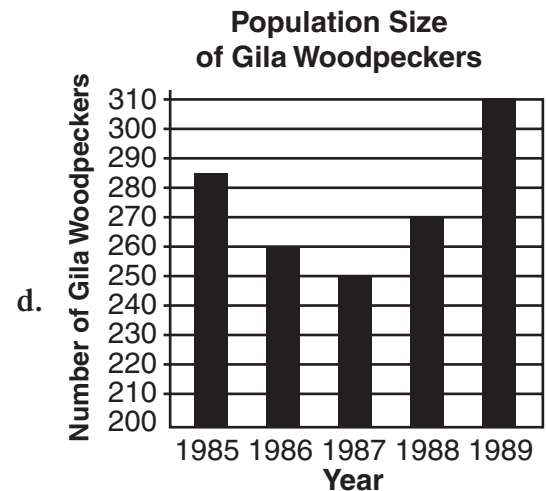
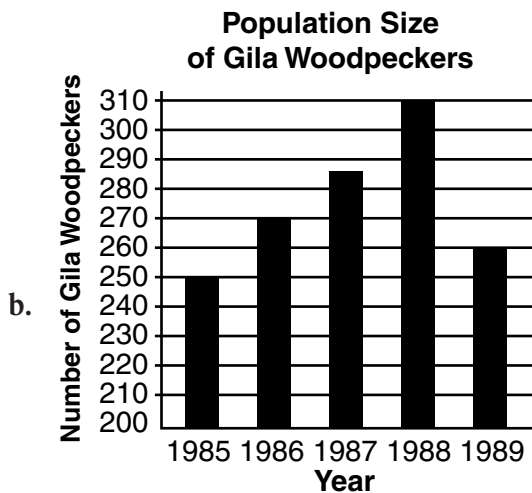
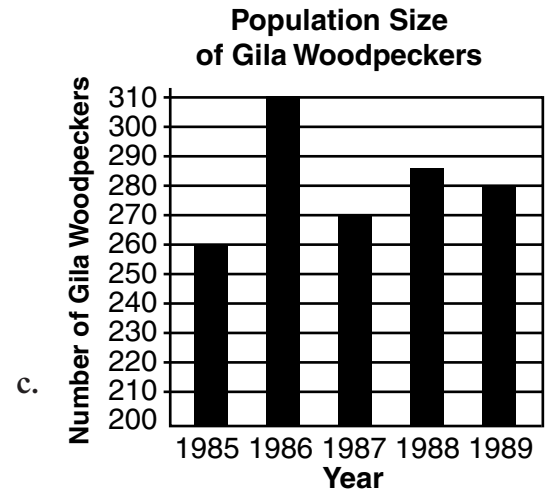
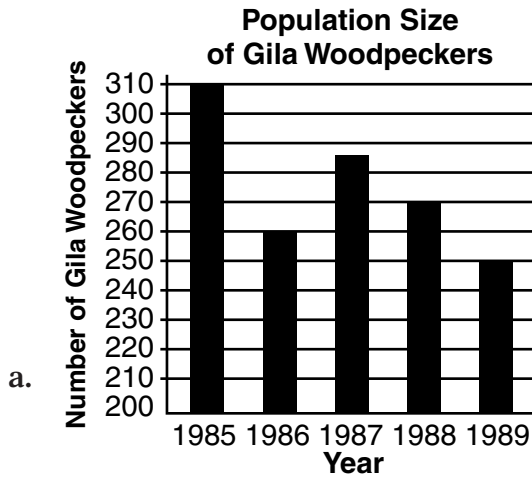

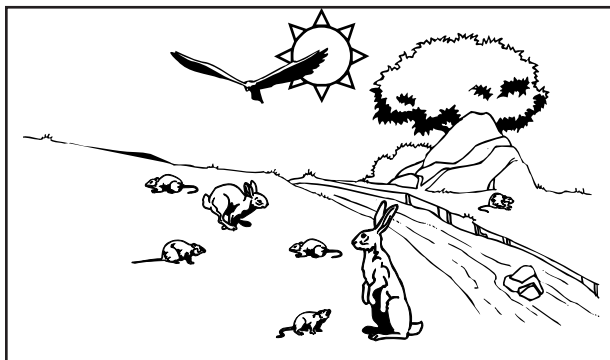

2. A limiting factor is something that limits the size of a population in an ecosystem. According to this definition, which of these could be a limiting factor for the rabbits in the picture?
- f. number of edible plants
 - g. human homes and buildings
 - h. lack of water
 - j. cloudy weather

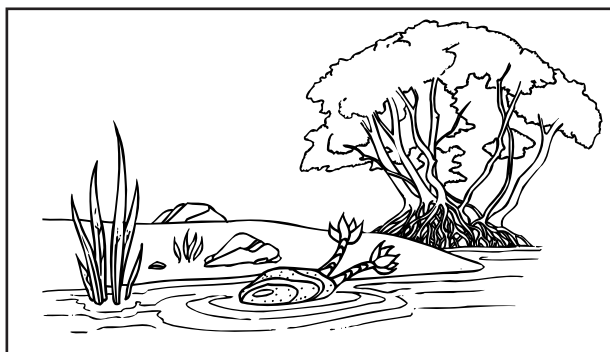

3. The picture shows a sprouted mangrove seed floating away from a mangrove swamp in an ocean current. According to this picture, ocean currents benefit the mangrove species most by _____.
- a. drowning its sprouted seeds
 - b. providing fresh water for the seeds to grow
 - c. spreading its sprouted seeds to new coastal areas
 - d. making it easier for seagulls to eat its sprouted seeds

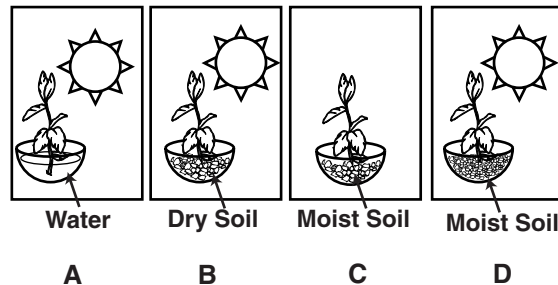

4. The picture shows four plants set up in an experiment. When left under these conditions for a week, which plant will have grown the most?
- f. plant in box A
 - g. plant in box B
 - h. plant in box C
 - j. plant in box D

ALGAE BLUEBERRY BUSH GRASS

5. Which of these belongs with the group above?
- a. mushroom
 - b. moth
 - c. pine tree
 - d. worm



DIRECTIONS

Read each question. Then, on your answer sheet, mark the answer choice that you think is best.

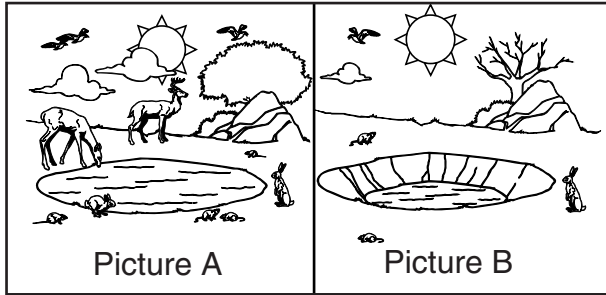

- 1** The ecosystem in Picture A is healthy while the ecosystem in Picture B is not. What seems to be needed to help the organisms in Picture B survive?

- A** more sunny days
- B** more plants
- C** fewer predators
- D** more wind

- 2** Which of the choices below is a decomposer?

- F** mushroom
- G** grass
- H** cricket
- J** fish

- 3** Which statement best explains what a population is?

- A** A population is all of the animals in a habitat.
- B** A population is all of the carnivores in an ecosystem.
- C** A population is all of the animals of one specific species in an ecosystem.
- D** A population is all of the animals that an ecologist can count in a habitat.

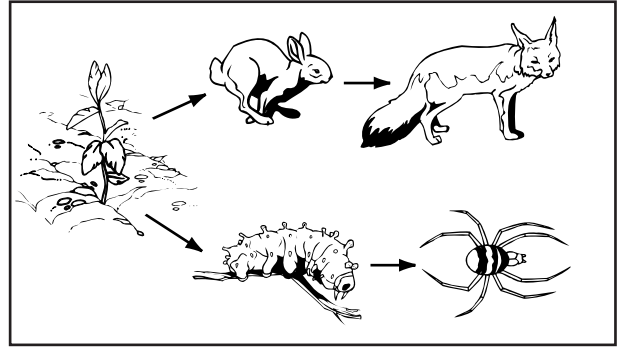

- 4** Which organism in this food web is a herbivore?

- F** plant
- G** caterpillar
- H** spider
- J** fox

5 Mercury is closer to the Sun than Earth is. What might be the reason that there are no living ecosystems on Mercury?

- A** Mercury is too small a planet.
- B** Mercury is too hot.
- C** Mercury needs a moon to have life on it.
- D** Mercury is too cold.

6 The main problem that occurs when humans pour their waste into rivers is

- F** the greenhouse effect
- G** the rivers overflow and destroy farms, roads, and personal property
- H** the aquatic organisms living in the area are harmed
- J** the ozone layer is affected

Directions: Read Numbers 7–8 below. Then, on the lines that follow, write your answers in complete sentences.

7 In an ecosystem, there are plants, herbivores (plant eaters), and carnivores (meat eaters). Explain how all organisms are dependent on plants for food, even if they don't eat plants themselves. Draw a food chain as part of your explanation.

8 A family of rabbits finds a new field of grass to live in. At first they live, eat, and reproduce easily. Explain what will happen to this rabbit population's size and growth rate after some time in the new habitat. Draw a graph of the population over time as part of your answer.



DIRECTIONS

Choose the best answer choice for each of the following questions.

1. The composition of the air we breathe is about 78% nitrogen, 21% oxygen, and 1% other gases. Which of these graphs best illustrates this information?

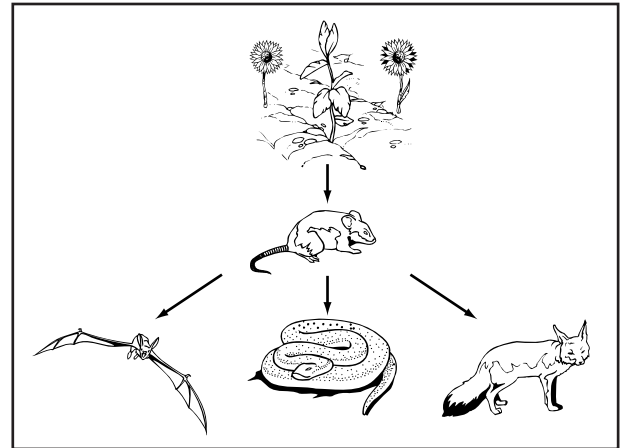
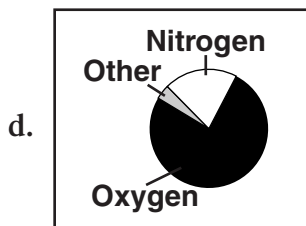
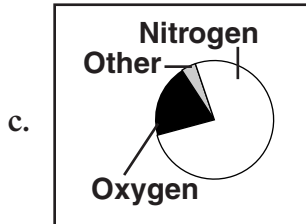
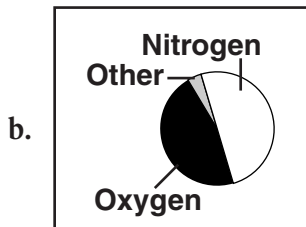
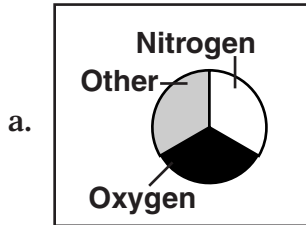

2. If more mice were added to a region, there would be more food for each of the following EXCEPT _____.
- f. plants
 - g. bats
 - h. snakes
 - j. foxes
3. What is the major characteristic of chemosynthesis?
- a. transfer of energy from one organism to another
 - b. change of nitrogen gas into a usable form for plants
 - c. conversion of sunlight into chemical energy
 - d. production of energy-rich food from chemicals

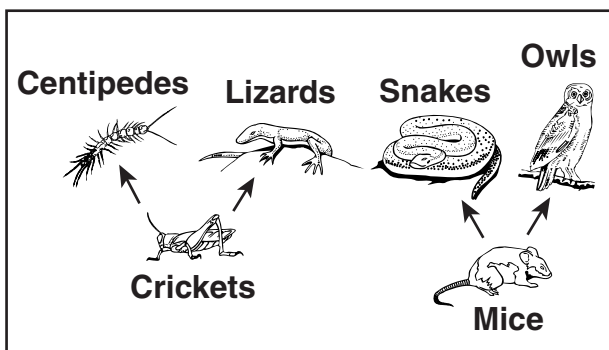

4. If all of the centipedes disappeared from the region, the species that would benefit most would be _____.
- snakes
 - mice
 - lizards
 - owls

RAIN HAIL SLEET

5. Which of the following belongs with the group shown above?
- snow
 - wind
 - grass
 - sand

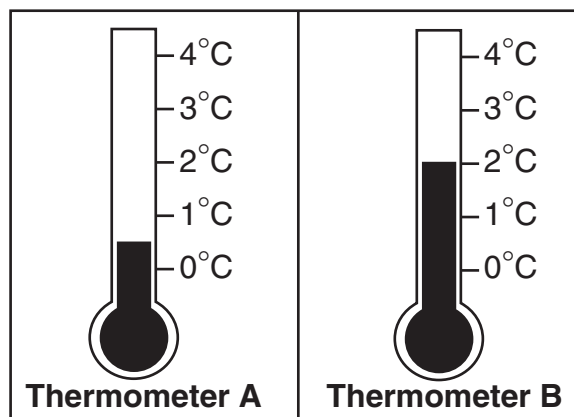

6. The temperature shown on Thermometer B is how much higher than the temperature shown on Thermometer A?
- 0.5°C
 - 1.0°C
 - 1.5°C
 - 2.0°C
7. Which of the following is the best explanation for farmers planting crops with nitrogen-fixing bacteria?
- Crops benefit from higher levels of nitrogen in the soil.
 - Crops benefit by developing a resistance to bacteria.
 - Bacteria benefit from higher levels of nitrogen in the soil.
 - Bacteria compete with crops for nitrogen.



DIRECTIONS

Read each question. Then, on your answer sheet, mark the answer choice that you think is best.

- 1** In which of the following processes is carbon dioxide consumed and oxygen produced?
- A** combustion
B respiration
C photosynthesis
D condensation
- 2** Which of the following factors is not considered to be part of a region's climate?
- F** population
G wind
H rainfall
J temperature

Directions: Children at the Lackawanna Summer Camp made a list of animals they saw in the forest around them and what the animals ate. Use the information in the list to answer Number 3 below.

Animal	What it Eats
Spider	Centipede
Lizard	Centipede
Hawk	Snake
Snake	Lizard

- 3** Which of the following food webs represents the part of the forest ecosystem that the children observed?

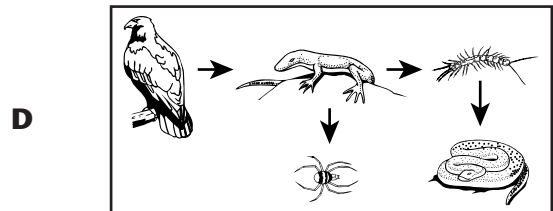
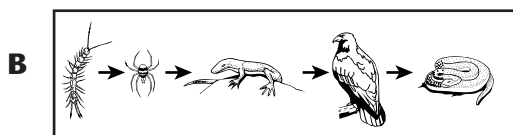
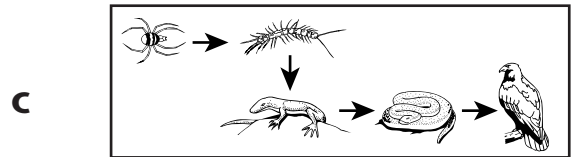
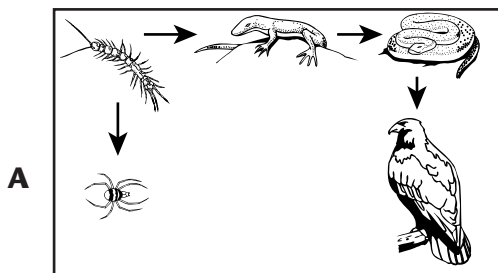

- 4** Acid rain is caused by automobile exhaust and factory smoke. Acid rain can be harmful to people, animals, and plants. Which of the following actions would decrease the occurrence of acid rain?

- F** moving factories closer together
- G** building highways closer to cities
- H** driving automobiles less often
- J** increasing the hours of factory operation

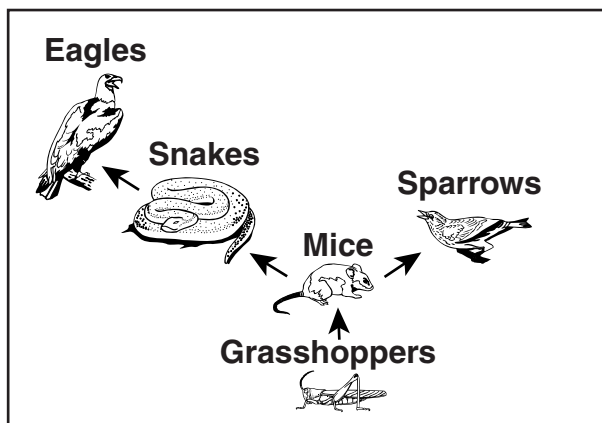

- 5** Which of the statements below is true?

- A** Energy transfers from sparrows to grasshoppers.
- B** Energy transfers from eagles to snakes.
- C** Energy transfers from grasshoppers to mice.
- D** Energy transfers from snakes to mice.

Directions: Read Number 6 below. Then, on the lines that follow, write your answer in complete sentences.

- 6** Food webs are composed of predators and prey. Are there more predators or prey? Give a short explanation for your answer.



DIRECTIONS

Choose the best answer choice for each of the following questions.

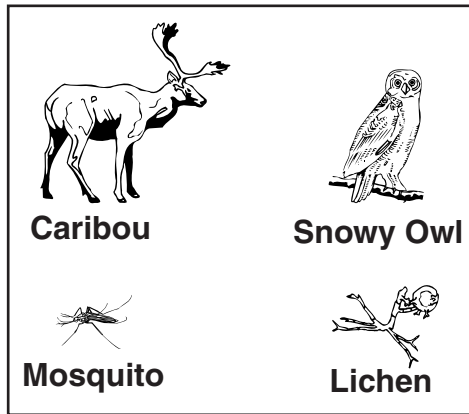

- The picture shows organisms from one of the major biomes on Earth. In which biome are all of these organisms able to live?
 - tropical rain forest
 - tundra
 - desert
 - ocean
- In general, estuaries benefit ocean fish most by _____.
 - being good areas for humans to fish
 - serving as nurseries for their young
 - being completely freshwater ecosystems
 - having low levels of nutrients

- What is the purpose of setting aside large areas of desert to be national parks?
 - to help increase rainfall in the desert
 - to provide more space for constructing new buildings
 - to prevent animals from eating each other
 - to protect habitats for desert plants and animals

**Average Monthly Temperature
in Temperate Deciduous Forest**

Month	Average Temperature (°C)
January	-18
February	-10
March	-9
April	5
May	15
June	25
July	31
August	33
September	28
October	18
November	5
December	-8

- According to this information, which month has an average temperature higher than 26 degrees Celsius?
 - June
 - April
 - July
 - October

LAKE POND STREAM

5. Which of these belongs with the group above?
- river
 - iceberg
 - coral reef
 - lily pad

Abiotic Features of Ecosystems

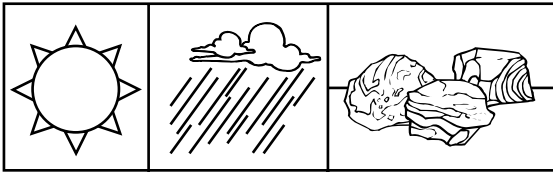

6. The pictures show three abiotic features of ecosystems. Which of the following is the major characteristic of abiotic features?
- They are all non-living.
 - They are in all ecosystems.
 - They are necessary for life.
 - They are impossible to measure.

7. Maria wanted to find out if pond plants would grow better in the light or in the dark. She put some pond plants in a container of water in a dark closet. This experiment could be improved by putting a second group of pond plants in a container of water _____.
- under a light-colored cloth
 - in a different closet
 - under an electric blanket
 - in the sunlight
8. Which of these is the major characteristic of climax communities?
- A place that has animals and plants that have reached a stable stage
 - Succession that begins in a place that does not have any soil and did not ever support living organisms
 - A place that contains multiple varieties of lichens
 - Succession that begins in a place that already has soil and was once the home of living organisms



DIRECTIONS

Read each question. Then, on your answer sheet, mark the answer choice that you think is best.

- 1** Which sentence provides the best definition of a pioneer species?
- A** Pioneer species are the last organisms to move into an ecosystem.
 - B** Pioneer species are usually carnivores.
 - C** Pioneer species are the first organisms to move into an ecosystem.
 - D** Pioneer species are species found only in the western United States.

- 2** Field biologists want to measure the amount of rainfall in a grassland biome. When they collect rain in their rain gauge, the amount they record will probably be in
- F** meters
 - G** kilometers
 - H** grams
 - J** centimeters

- 3** Which of these is an example of water pollution?
- A** lily pads growing throughout a pond
 - B** soda cans at the bottom of a lake
 - C** the greenhouse effect
 - D** muddy water

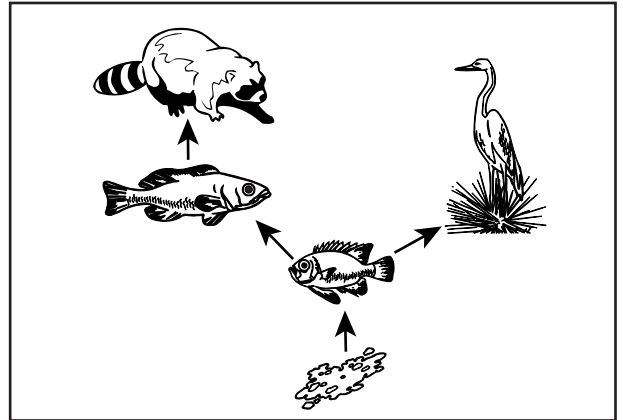

- 4** The picture above is a way to represent
- F** the number of organisms in a species
 - G** the predator/prey interactions in a habitat
 - H** the importance of water in an ecosystem
 - J** primary succession in an ecosystem

Directions: This chart shows how lima bean plants grew in different kinds of planting material. Use the information in the table to answer Numbers 5–6 below.

Growth of Lima Bean Plants in Different Materials

Material	Height (cm)	Number of Leaves
Potting Soil	4.5	6
Sand	3.5	6
Gravel	2	6
Water	1	2

5 In which material did the lima beans grow tallest?

- A** water
- B** sand
- C** gravel
- D** potting soil

6 A lima bean plant was grown for the same amount of time as the other plants, but it was grown in mud. It grew 1.2 centimeters and had 1 leaf, which is similar to the plants grown in

- F** potting soil
- G** sand
- H** gravel
- J** water

Directions: Read Number 7 below. Then, on the lines that follow, write your answer in complete sentences.

7 A forest is cut down to make space for a new mall. What will be some of the effects of this human activity on the forest ecosystem?



DIRECTIONS

Choose the best answer choice for each of the following questions.

Movement of the North American Continent: 1998–2001

Year	Distance Moved from First Measurement
1998	5.2
1999	10.4
2000	15.6
2001	?

- Scientists studying plate tectonics compiled the chart above showing the distance that the North American continent moves from year to year. Based on this information, how far will the continent have moved from the first measurement in the year 2001?
 - 10.4 cm
 - 15.6 cm
 - 20.8 cm
 - 26.0 cm
- Which of the following is NOT evidence used to support the theory that Earth's continents were once connected?
 - The continents can support animal life.
 - Similar geological features are found on widely separated continents.
 - The coastlines of some continents fit together like puzzle pieces.
 - Similar fossils are found on widely separated continents.

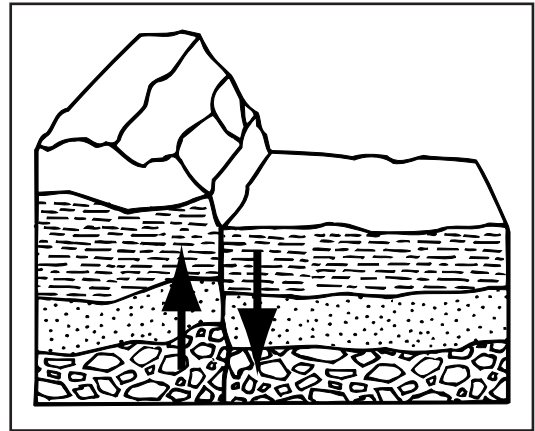

- Which process is taking place in the picture above?
 - soil erosion
 - river flooding
 - iceberg creation
 - mountain building
- The Mariana Islands in the Pacific Ocean were formed by volcanic action. Which of the following is most likely true?
 - There are glaciers near the Mariana Islands.
 - Tectonic plates collide near the Mariana Islands.
 - The Mariana Islands are larger than most islands.
 - The Mariana Islands are uninhabited.

5. Dale collected a rock at several different distances from a fault line. In order to be sure that these rocks are the best examples of the types of rocks found at each distance, Dale should _____.
- choose the largest rocks from each place
 - make sure all of the rocks have different shapes
 - collect many rocks from each area
 - find only rocks of one color
6. The most likely cause of earthquake activity on the West Coast of the United States is _____.
- landslides from coastal mountains
 - the slipping of tectonic plates
 - tidal effects from the Pacific Ocean
 - seasonal temperature changes
7. Under which of the following headings in a table of contents would the most information about Pangaea be found?
- How to Clean and Prepare Fossil Samples
 - Alfred Wegener and Continental Drift
 - The Movement of Glaciers
 - All You Need to Know About the Asthenosphere
8. Which of the following is LEAST likely to result from seafloor spreading?
- magma flowing upward toward cracks
 - creation of mid-ocean ridges
 - a reversal in the magnetic fields of the north and south poles
 - magma cooling and forming solid, new seafloor
9. Which kind of scientist would most likely use a graph titled “Magnitude of some Earthquakes”?
- biochemist
 - geologist
 - toxicologist
 - physicist



DIRECTIONS

Read each question. Then, on your answer sheet, mark the answer choice that you think is best.



- 1** When tectonic plates collide, molten rock from beneath the crust of the earth is sometimes forced up through the surface. When this occurs, it is called
- A** a mountain
 - B** an earthquake
 - C** a rift
 - D** a volcano

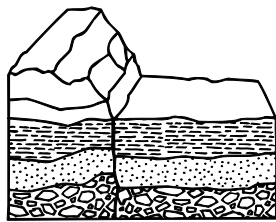

- 2** Which of the following is not caused by plate tectonics?
- F** earthquakes
 - G** volcanoes
 - H** mountain building
 - J** tidal cycles

- 3** A scientist measured the distance moved by a tectonic plate over the course of a year. The distance would best be recorded in what units?

- A** kilometers
- B** centimeters
- C** liters
- D** miles

- 4** Why is it hazardous to build a house on a fault line?

- F** The house will be too costly to maintain.
- G** The house may be destroyed by an earthquake.
- H** The house will be difficult to heat.
- J** The house will be too small.

- 5** The gradual movement of the continents across the surface of Earth is best explained by which of the following?

- A** gravitational attraction
- B** plate tectonics
- C** solar radiation
- D** the greenhouse effect

Standardized Test Practice Chapter 7 *Plate Tectonics*

6 Some mountains are formed by the collision of two tectonic plates. Which of the diagrams below shows a situation that would result in the formation of such mountains?

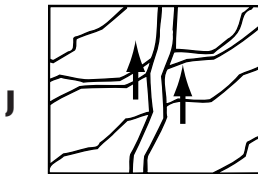
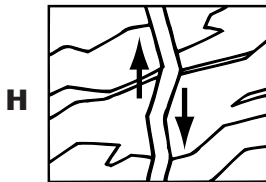
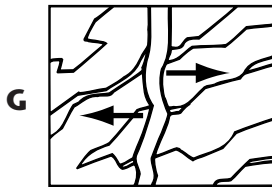
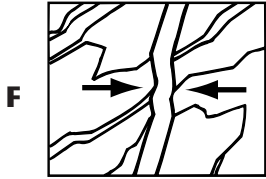

7 Which of the following diagrams represents a fault line?

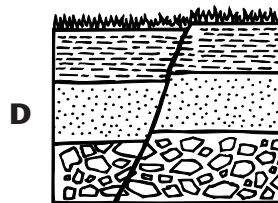
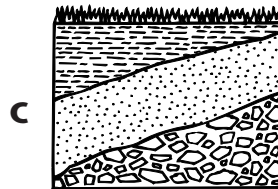
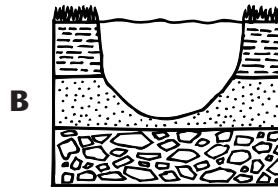
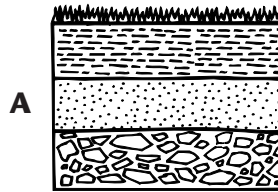

Directions: Read Number 8 below. Then, on the lines that follow, write your answer in complete sentences.

8 Similar fossils and rock formations have been found in western Africa and eastern South America. Explain how this information can be used to support the theory of plate tectonics.



DIRECTIONS

Read each question and choose the best answer. Then fill in the correct answer on your answer document.

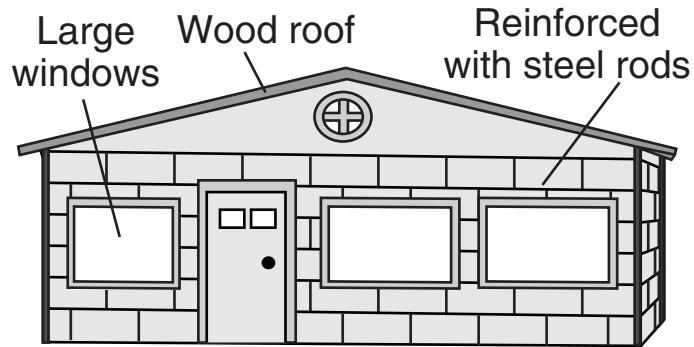

1. Which characteristic of this building shows that it was designed to better withstand an earthquake?
 - a. There are many large windows.
 - b. The walls are light in color.
 - c. The bricks are reinforced with steel.
 - d. The roof is made of wood.
-
2. Engineers have developed experiments to test the abilities of different building materials to withstand earthquakes. Which factor would have the LEAST affect on the results of these experiments?
 - f. The strength of the material
 - g. The forces applied to the material
 - h. The color of the material
 - j. The surface on which the material is placed
 3. Most earthquakes will exhibit all of these types of waves EXCEPT _____.
 - a. primary waves
 - b. secondary waves
 - c. tidal waves
 - d. surface waves

4. Which has been the greatest benefit of studying past earthquakes in an area?
- f. Improving earthquake-advisory warnings
 - g. Minimizing damage from future earthquakes
 - h. Improving earthquake research techniques
 - j. Preventing new earthquakes from occurring

SEISMOGRAPH S-WAVES FOCUS

5. Which of these belongs with the group above?
- a. Tephra
 - b. Basalt
 - c. Epicenter
 - d. Mantle
6. Under which heading in a table of contents would the most information about subduction be found?
- f. Tsunamis
 - g. Earthquakes
 - h. Plate Tectonics
 - j. Volcanoes

7. Which of these is LEAST likely to be observed during a volcanic eruption?
- a. Lava
 - b. Pyroclastic flow
 - c. Tephra
 - d. Tsunami
8. Which of the following is NOT a characteristic of a shield volcano?
- f. broad, sloping sides
 - g. forms where plates are moving apart
 - h. violently erupts
 - J made of basaltic lava
9. Michelene and Peter were looking at photographs and were trying to identify the type of volcano in each. One photograph showed a volcano that wasn't very tall, was near other volcanoes, and was composed of a lot of ash. According to this information, what type of volcano was in the photograph?
- a. Composite volcano
 - b. Cinder-cone volcano
 - c. Shield volcano
 - d. Fissure volcano



DIRECTIONS

Read each question. Then, on your answer sheet, mark the answer choice that you think is best.

- 1** Which of these represents a strike-slip fault?

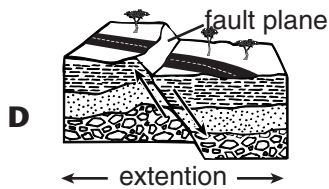
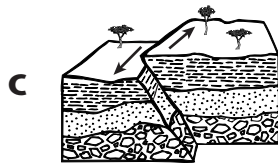
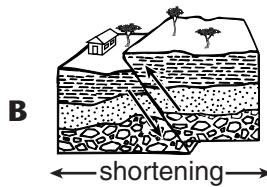
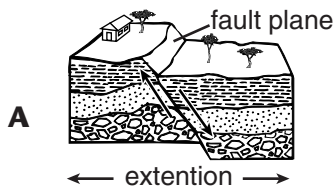

- 2** Which of the following causes tectonic plate motion?

- F** convection
G conduction
H diffusion
J transmission

- 3** Which of the following would most likely come from a shield volcano?

- A** basaltic lava
B tephra
C explosive gas
D ash

- 4** Which of the following would most likely be used to record earthquakes?

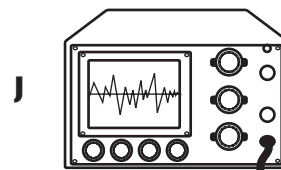
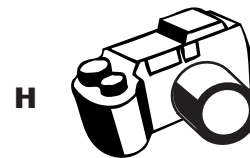
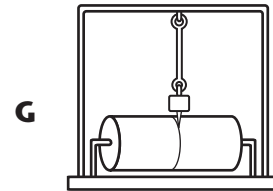
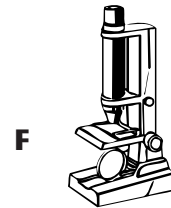

5 People sometimes think that earthquakes that occur at sea are harmless. In fact, these “oceanquakes” can cause devastation on land by way of

- A** p-waves
- B** s-waves
- C** tsunamis
- D** seismicity



6 Which of the following best explains why volcanoes in the Pacific Ocean area are clustered around the Ring of Fire?

- F** It is because of random chance.
- G** The heavy weight of ocean water presses upon the Pacific plate, forcing magma to rise to the surface.
- H** The coasts of the Pacific Ocean are especially vulnerable to volcanic activity.
- J** The Pacific plate meets the continental plates, allowing magma to rise to the surface.

Directions: Read Numbers 7 and 8 below. Then, on the lines that follow, write your answer in complete sentences.

7 Use what you know about tectonic plates, molten magma, and the term “hot spot” to explain the location of the Hawaiian Islands. Draw a diagram as a part of your answer.

8 Describe some of the ways in which researchers have tried to predict earthquakes.



DIRECTIONS

Choose the best answer choice for each of the following questions.

Ages of Fossils Found at Site X

Fossil	Age (years)
Q	10,000
R	20,000
S	15,000
T	5,000
U	10,000

1. The chart above shows the ages of some fossils found at a particular archeological site. Which of the following graphs best represents these data?

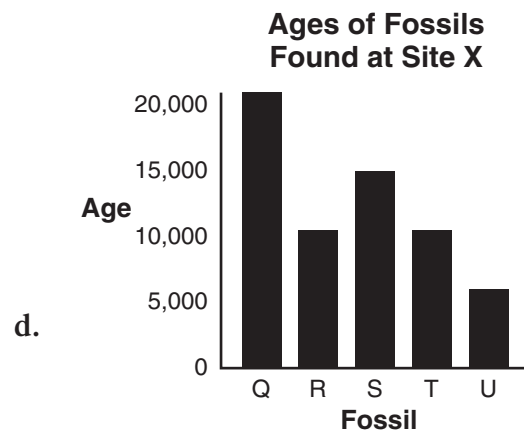
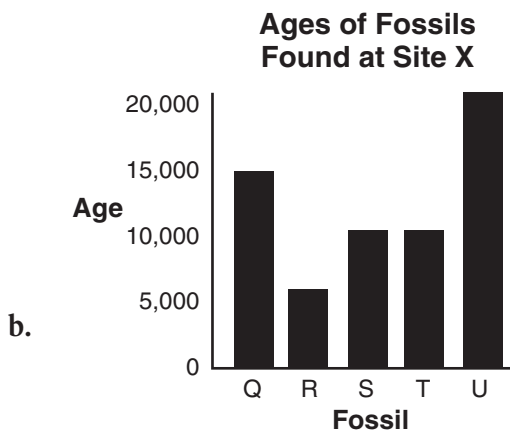
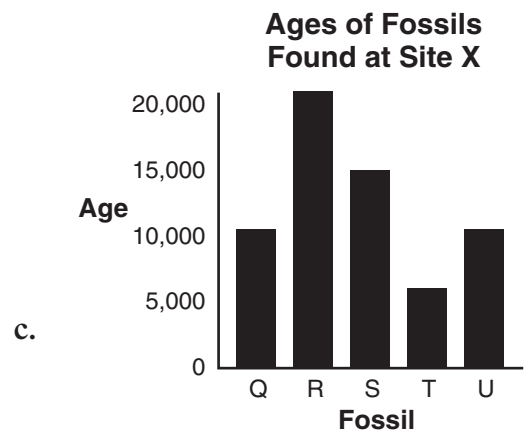
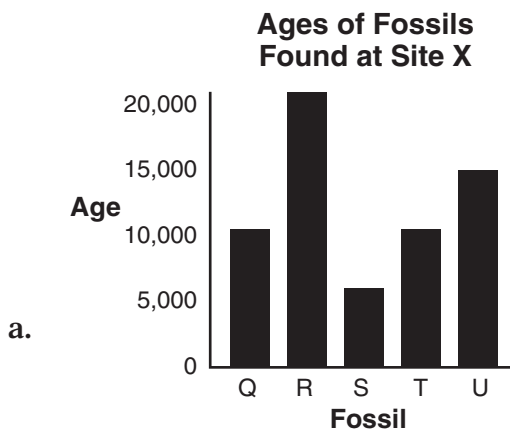

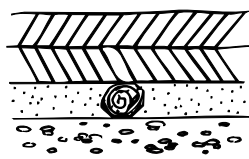

Q



R

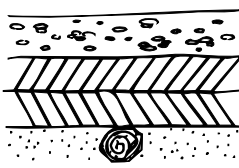

S



T

2. Which is the order, from first to last, of the formation of a fossil?

- f. R, T, Q, S
- g. Q, R, S, T
- h. Q, S, T, R
- j. S, Q, R, T

After	Amount Left
0	All
5 minutes	$\frac{1}{2}$
10 minutes	$\frac{1}{4}$
15 minutes	?

3. These data show how much of a radioactive sample is left after each half-life. The sample's half-life is 5 minutes. If everything remains the same, what fraction of the radioactive isotope will be left after 15 minutes?

- a. 0
- b. $\frac{1}{16}$
- c. $\frac{1}{8}$
- d. $\frac{1}{3}$

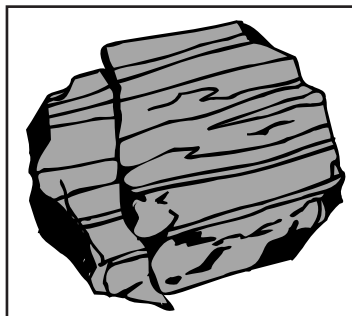

4. The most likely cause of the angular unconformity in the picture is _____.
- f. weathering
 - g. radioactive decay
 - h. erosion
 - j. earthquake
5. What is the purpose of using carbon-14 methods on samples from archeological sites?
- a. to preserve them
 - b. to determine their age
 - c. to dig them out of the ground
 - d. to clean them



DIRECTIONS

Read each question. Then, on your answer sheet, mark the answer choice that you think is best.

- 1** Which of the following would not be called an original remains fossil?

A a plant fossil caught in a tar pit
B a fly caught in amber
C a dinosaur tooth
D a frozen woolly mammoth

- 2** Which of these pictures is an example of a trace fossil?

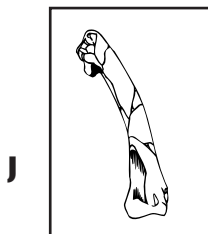
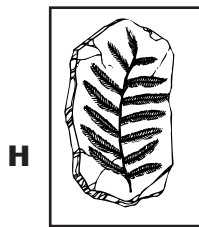
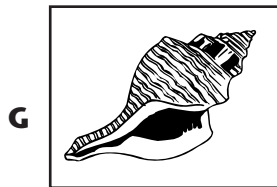
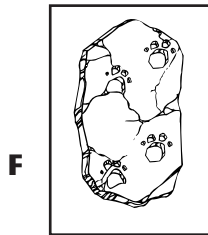

- 3** Sediments increase the chance that a dead organism will turn into a fossil by

A keeping it afloat
B helping it be decomposed by bacteria
C protecting it from being decomposed
D giving it fertilizer

- 4** Which diagram represents alpha decay?

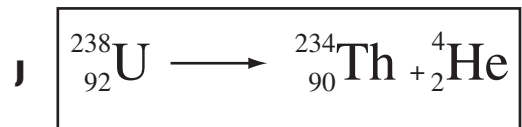
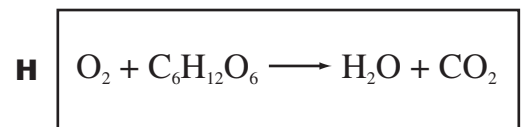
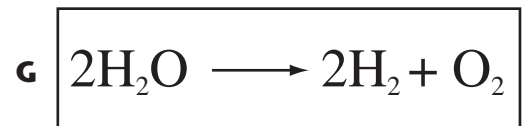

5 An archeologist uses dating methods to determine the age of a fossil. The age she writes in her chart was most likely measured in

- A** years
- B** light-years
- C** minutes
- D** days

6 Which of these sentences gives the best definition of half-life?

- F** Half-life is the amount of time it takes for an animal to reach middle age.
- G** Half-life is the amount of time it takes for half of a sample of atoms to decay.
- H** After two half-lives, all of the atoms in a sample are gone.
- J** Half-life is when a chemical reaction is half over.

Directions: Read Number 7 below. Then, on the lines that follow, write your answer in complete sentences.

7 Max and Gladys are digging at an archeological site. As they dig down through different layers of sediment, they find all kinds of fossils. Explain how they can figure out which fossils are older and which are younger, using the term “superposition” in your answer. Draw a diagram as part of your explanation.



DIRECTIONS

Choose the best answer choice for each of the following questions.

**A****B****C****D**

1. Which of the following lists the the continents' positions from earliest to latest?
 - a. A, B, C, D
 - b. D, C, B, A
 - c. C, A, B, D
 - d. B, D, C, A

2. In a table of contents, under which heading would you find the most information about dinosaurs?
 - f. Proterozoic Era
 - g. Paleozoic Era
 - h. Mesozoic Era
 - j. Cenozoic Era

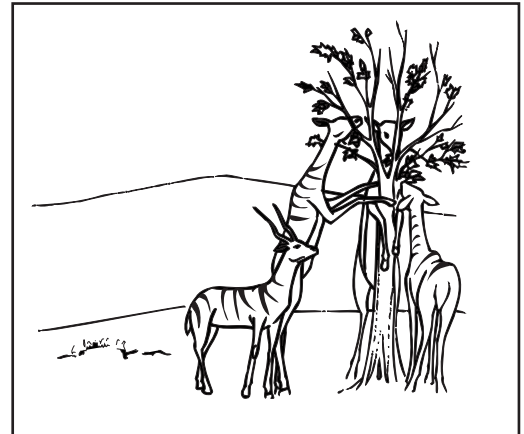

3. What characteristic will help the deer be successful in this habitat?
 - a. their stripes
 - b. their long necks
 - c. their dark color
 - d. their small tails

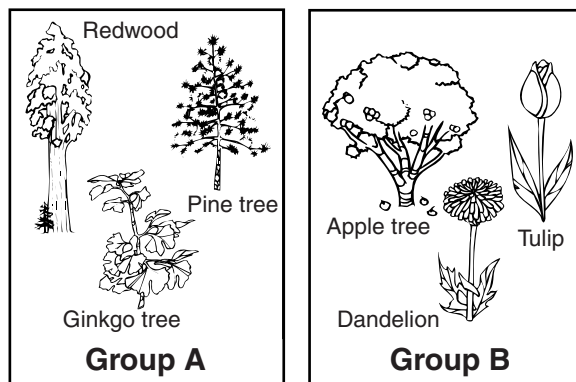

4. The plants in Group A are different from the plants in Group B because only the plants in Group B have _____.
- f. flowers
 - g. pine cones
 - h. branches
 - j. roots

5. In general, having scaly skin benefits reptiles most by _____.
- a. allowing them to swim easily
 - b. keeping them from losing water
 - c. helping them to fly to high tree branches
 - d. keeping them warm during cooler seasons

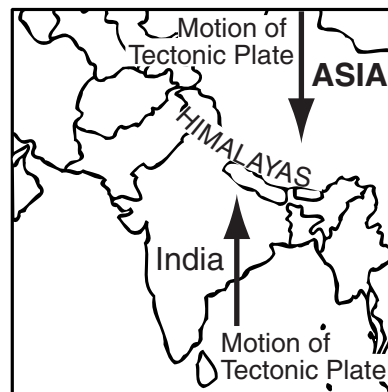

6. Which of these processes most contributed to the formation of the Himalayas?
- f. collision of continents
 - g. melting of glaciers
 - h. erosion by wind and water
 - j. landslides from monsoons



DIRECTIONS

Read each question. Then, on your answer sheet, mark the answer choice that you think is best.

- 1** Which of these is a warm-blooded animal?
- A** snake
 - B** tropical fish
 - C** bird
 - D** earthworm
- 2** Which sentence gives the best description of natural selection?
- F** Natural selection is how animals choose the habitat they will live in.
 - G** Natural selection is when humans make national parks.
 - H** Natural selection is when animals that are better suited to an environment survive more successfully.
 - J** Natural selection is how animals change their behavior and their physical appearance in order to get more food.
- 3** About 66 million years ago, something happened on Earth that killed off many species of plants and animals. This phenomenon is called
- A** continental drift
 - B** mass extinction
 - C** an eon
 - D** photosynthesis
- 4** Several billion years ago, cyanobacteria began photosynthesizing. What did this add to Earth's atmosphere?
- F** water
 - G** carbon dioxide
 - H** sunlight
 - J** oxygen
- 5** Which of the following is not a geological time period?
- A** Pangaea Era
 - B** Cenozoic Era
 - C** Mesozoic Era
 - D** Paleozoic Era

Directions: Read Numbers 6–7 below. Then, on the lines that follow, write your answers in complete sentences.

6 Monarch butterflies are unpleasant tasting to animals like frogs. Another species of butterfly evolved with wings that look similar to the monarch butterfly’s wings. Explain how this will affect the survival of the new butterfly.

7 Over the course of Earth’s history, many different organisms have existed, such as cyanobacteria, trilobites, and dinosaurs. Pick one organism, note the era(s) in which it existed, and describe its main characteristics.



DIRECTIONS

Choose the best answer choice for each of the following questions.

1. The gradual change in the length of your shadow over the course of the day is caused by _____.
 - a. the revolution of Earth around the Sun
 - b. the rotation of Earth on its axis
 - c. the revolution of the Moon around Earth
 - d. the rotation of the Moon on its axis
2. The effect of the Sun is strongest when the Sun is directly overhead. At which of the times listed below would a person who sunburns easily be best advised to stay indoors?
 - f. 8 A.M.
 - g. 12 noon
 - h. 4 P.M.
 - j. 8 P.M.
3. The gravitational pull of the Moon has a greater effect than the pull of the Sun on the tidal changes in Earth's oceans. The most likely reason for this is _____.
 - a. the Sun is closer to Earth
 - b. the Moon is closer to Earth
 - c. the Sun is larger than the Moon
 - d. Earth is larger than the Moon
4. Which of the following occurs when Earth is positioned directly between the Sun and the Moon, making the Moon invisible to observers on Earth?
 - f. a lunar eclipse
 - g. a solar eclipse
 - h. a full Moon
 - j. a waxing Moon
5. The fact that Earth's axis is tilted 23.5° is responsible for _____.
 - a. the change between day and night
 - b. the changing of the seasons
 - c. solar eclipses
 - d. lunar eclipses
6. Which of these sources would be the most helpful to determine which telescope gives the best view of the stars?
 - f. the prices of the telescopes
 - g. the data from an objective test
 - h. advertisements for the telescopes
 - j. the colors of the telescopes

7. In a study of the Sun's location during solstices, which question would be the most important to answer?
- What is the Sun's distance north or south of the equator?
 - How many scientists have studied solstices?
 - Is the temperature at the equator affected by the Sun's location?
 - How many hours of sunlight are there on the summer solstice?
8. An ellipse is an elongated, closed curve. According to this information, which of the following orbits is an ellipse?

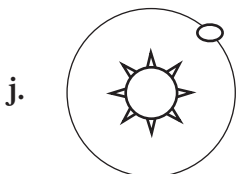
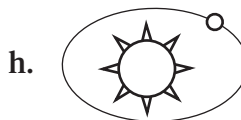
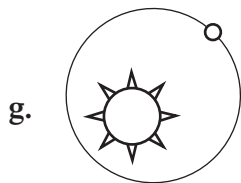
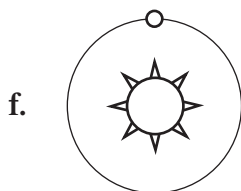

- equinox
 - solstice
 - new moon
 - eclipse
9. Which of the following occurs when the Sun is directly above Earth's equator?
- equinox
 - solstice
 - new moon
 - eclipse
10. Which of the following best describes an impact basin?
- the white glow around the edges of the Moon
 - a round, three-dimensional object
 - the hollow left behind by an object striking the Moon
 - an elongated, closed curve
11. Early data from the *Lunar Prospector* indicated the presence of hydrogen in crater rocks at the Moon's poles. According to this data, what is the most likely theory that could be made?
- The Moon's core is 600 kilometers in diameter.
 - Ice may exist in the floors of craters at the Moon's poles.
 - Ice may exist in the floors of craters only at the Moon's north pole.
 - Water may exist 600 kilometers under the Moon's surface.



DIRECTIONS

Read each question. Then, on your answer sheet, mark the answer choice that you think is best.

- 1** The largest crater on the Moon is 12 kilometers deep and 2,500 kilometers in diameter. If craters are caused by large objects striking the lunar surface, the crater was probably caused by a

- A** pebble
- B** planet
- C** galaxy
- D** meteorite

- 2** Which of the following diagrams depicts a lunar eclipse?

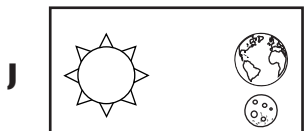
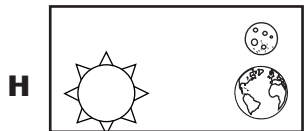
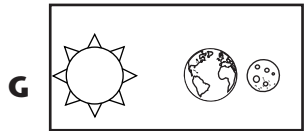
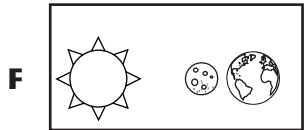

- 3** Which of the diagrams below depicts an equinox?

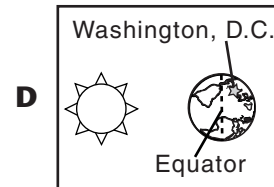
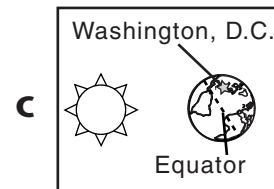
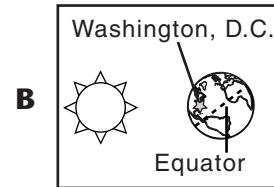
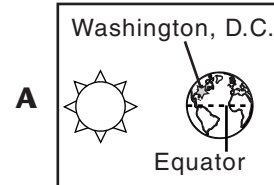

- 4** The diameter of Earth would best be measured using what units?

- F** centimeters
- G** kilometers
- H** kilograms
- J** inches

5 Renah is painting her house. What color should she paint it so that it will reflect the most light from the Sun?

- A** white
- B** orange
- C** green
- D** black

6 The Moon is visible to us because the Moon

- F** reflects light from the Sun
- G** reflects light from Earth
- H** produces light through fusion
- J** produces light through combustion

Directions: Read Numbers 7–8 below. Then, on the lines that follow, write your answers in complete sentences.

7 For thousands of years, people were convinced that Earth was flat. Eventually, they saw enough evidence that they were convinced that Earth was shaped like a sphere. Give an example of evidence that Earth is a sphere.

8 Use what you know about the positions of Earth, the Moon, and the Sun to explain why we see different phases of the Moon.



DIRECTIONS

Choose the best answer choice for each of the following questions.

Characteristics of Some Planets

Planet	Distance from the Sun (millions of kilometers)	Diameter (km)
Mercury	58	4,880
Venus	108	12,104
Earth	149	12,756
Mars	228	6,787

- According to this information, which planet is more than 200 million kilometers from the Sun?
 - Mercury
 - Venus
 - Earth
 - Mars
- What has been the greatest benefit of sending probes out into the solar system?
 - providing detailed information about the other planets
 - improving the quality of communication systems on Earth
 - explaining the factors that cause changes in the weather
 - finding new materials for use in industry
- Lisa wanted to observe the planet Jupiter with a telescope. Under which of the following conditions would she best be able to do this?
 - a day with a clear sky
 - a night with a clear sky
 - a rainy day
 - a rainy night
- George's parents warned him not to stare directly at the Sun during a solar eclipse. Why did they give him that warning?
 - The Sun is always hidden behind clouds during an eclipse.
 - Staring at the Sun during an eclipse damages the eyes.
 - Eclipses happen often, and George will be able to see another.
 - The Moon blocks the view of the Sun during an eclipse.

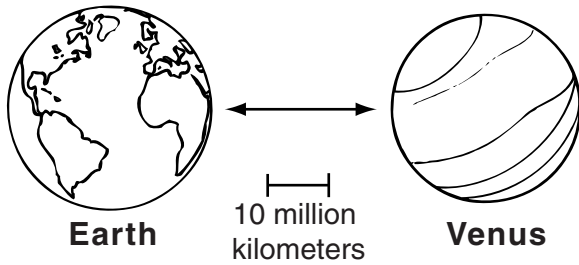

5. Approximately how far apart are Venus and Earth in the picture above?
- 30 million kilometers
 - 40 million kilometers
 - 50 million kilometers
 - 60 million kilometers

VENUS MARS NEPTUNE

6. Which of the following belongs in the group above?
- The Milky Way
 - Titan
 - Sirius
 - Mercury

Earth's Tilt	Toward Sun	Away from Sun	Toward Sun		
Season	Summer	Fall	Winter	Spring	Summer

7. According to the chart, when the northern hemisphere of Earth is tilted away from the Sun, the season will be _____.
- spring
 - summer
 - fall
 - winter
8. A science class has studied the characteristics of different asteroids. Which of the following is the best explanation for an asteroid with many craters?
- Craters are revealed when an asteroid's crust burns up in the atmosphere.
 - Craters were made when the asteroid was collected by scientists.
 - The asteroid has had many collisions over a long period of time.
 - The asteroid is composed of very fragile materials.



DIRECTIONS

Read each question. Then, on your answer sheet, mark the answer choice that you think is best.

- 1** A scientist is attempting to classify a large object in space. The scientist has determined that the object is in orbit around the planet Jupiter. The object is most likely a

A planet
B star
C moon
D meteor

- 2** Which of the following would be measured using kilometers?

F the diameter of Mars
G the weight of Mars
H the density of Mars
J the age of Mars

- 3** People who see meteors burning up in Earth's atmosphere often confuse them with stars. The objects that people refer to as shooting stars are actually meteors. People probably confuse meteors with stars because meteors

A appear as tiny, bright lights in the sky
B are as large as stars
C are pieces that break off from comets
D travel at very high speeds

- 4** Which of the diagrams below shows the three planets in the correct order of their distance from the Sun?

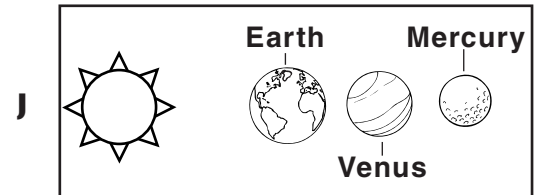
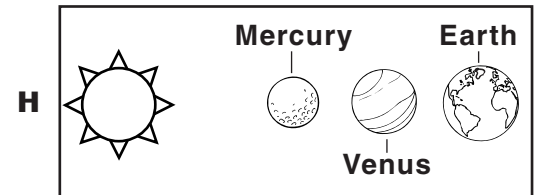
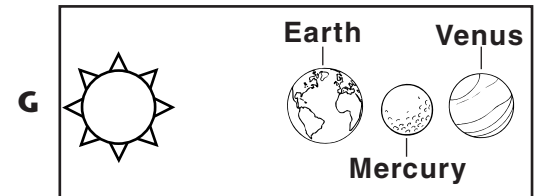
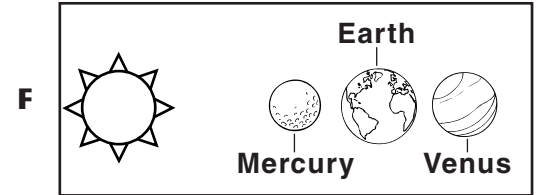

- 5** The planet Mars has seasons similar to those on Earth. The most likely reason for this is
- A** Mars is the same distance from the Sun as the Earth
 - B** Mars is tilted on its axis in the same way as Earth
 - C** Mars is traveling at the same speed as Earth
 - D** Mars is the same size as Earth
- 6** Using sunblock at the beach protects your skin by
- F** keeping your body dry
 - G** providing important nutrients
 - H** stopping solar radiation from affecting your skin
 - J** making the surface of your skin smoother and moister

Directions: Read Numbers 7–8 below. Then, on the lines that follow, write your answers in complete sentences.

- 7** Scientists are studying the structure and composition of asteroids. Explain how studying asteroids can help scientists better understand how Earth was formed.

- 8** A year is defined as the time it takes for a planet to make one revolution around the Sun. Use what you know about the positions of the planets to explain why a year on Mars is nearly twice as long as a year on Earth.



DIRECTIONS

Choose the best answer choice for each of the following questions.

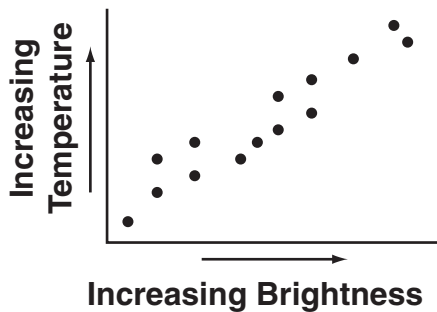
Main Sequence Stars

1. The graph shows the relationship between temperature and brightness for Main Sequence stars. What is a reasonable hypothesis that can be drawn from these data?
 - a. Hotter stars will have more surrounding planets than cooler stars.
 - b. Hotter stars last longer than cooler stars.
 - c. Cooler stars will be less bright than hotter stars.
 - d. Cooler stars are denser than hotter stars.

2. The Sun and the star Alpha Centauri shine with about the same brightness, yet the Sun appears to us to be several hundred times brighter than Alpha Centauri. Which of these is the most likely explanation for this?
 - f. Alpha Centauri is a larger star than the Sun.
 - g. The Sun generates energy through the process of fusion.
 - h. The Sun is much closer to Earth than Alpha Centauri.
 - j. Light from Alpha Centauri is blocked by the Moon.

Layers of the Sun's Atmosphere

Height	Name
Surface to 100 km	Photosphere
100 km to 2,000 km	Chromosphere
2,000 km to 10,000 km	Transition Zone
Above 10,000 km	Corona

3. According to the table, a height of 1,800 kilometers above the surface of the Sun will be part of which section of the Sun's atmosphere?
 - a. photosphere
 - b. chromosphere
 - c. transition zone
 - d. corona

WHITE DWARF SUPERGIANT NEUTRON STAR

4. Which of the following belongs with the group above?
- f. asteroid
 - g. planet
 - h. supernova
 - j. galaxy
5. Scientists have identified different types of galaxies. Which question would be the LEAST important to ask when identifying a galaxy's type?
- a. Does the galaxy have spiral arms?
 - b. How large is the galaxy?
 - c. What is the shape of the galaxy?
 - d. Does the galaxy orbit the Milky Way?

The Brightest Stars

Star	Distance (light-years)
Altair	16
Procyon	11
Sirius	9

6. The chart shows the distances from Earth to three of the brightest stars visible in the night sky. Which of the graphs below best represents these data?

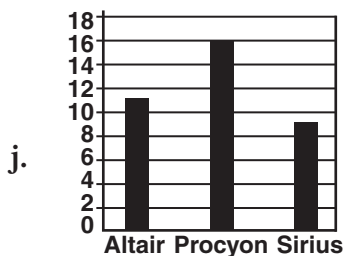
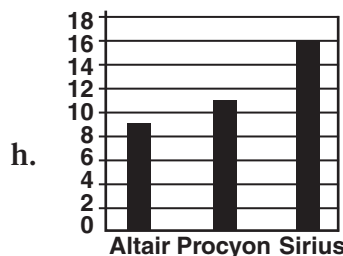
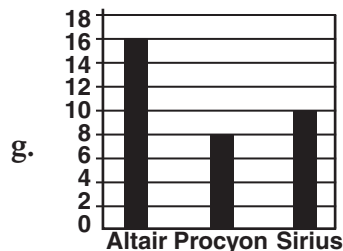
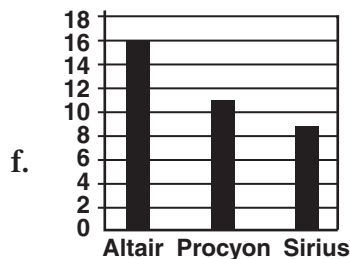

DIRECTIONS

Read each question. Then, on your answer sheet, mark the answer choice that you think is best.

- 1** In the core of a star, the temperature can reach heights unknown on Earth. The process by which stars generate energy is called
- A** photosynthesis
 - B** fusion
 - C** condensation
 - D** radiation
- 2** An astronomer measured the distance between two stars. The distance the astronomer recorded was probably measured in
- F** light-years
 - G** centimeters
 - H** tons
 - J** inches
- 3** Dan viewed two light bulbs of equal power. Bulb A appeared dimmer than Bulb B. A possible explanation for this is that
- A** Bulb B is farther away from Dan than Bulb A
 - B** Bulb A is farther away from Dan than Bulb B
 - C** Bulb A and Bulb B are next to each other
 - D** Bulb A and Bulb B are connected to the same battery
- 4** The Milky Way galaxy is visible from Earth most clearly when no other light is present. Which of the following is the best situation for viewing the Milky Way galaxy?
- F** in a large city at night
 - G** in a large city during the day
 - H** in a rural area at night
 - J** in a rural area during the day
- 5** Which of the following objects is closest to Earth?
- A** the Moon
 - B** the Sun
 - C** the planet Mars
 - D** the planet Jupiter
- 6** Which of the following inventions had the greatest effect on the study of astronomy?
- F** microscopes
 - G** automobiles
 - H** antibiotics
 - J** telescopes

7 An object that allows absolutely no light to escape would appear to be what color?

- A** black
- B** yellow
- C** blue
- D** white

8 In which of these would you expect to find a large number of stars?

- F** the solar system
- G** the rings of Saturn
- H** the asteroid belt
- J** the Milky Way galaxy

Directions: Read Numbers 9–10 below. Then, on the lines that follow, write your answers in complete sentences.

9 Two stars are shining with equal power, but to an observer on Earth, one star seems to be shining brighter than the other. What is a possible explanation for this?

10 According to the Doppler effect, when an object is moving away from an observer, the light from that object will undergo a red shift. Explain how this effect could be used to show that the universe is expanding.



DIRECTIONS

Choose the best answer choice for each of the following questions.

Helium	
Atomic Number	2
Symbol	He
Atomic Mass	4.003

- How many protons are in one helium atom?
 - 1
 - 2
 - 4
 - 6
- Homogeneous mixtures are so well mixed that the individual parts of the mixture can't be seen. According to this definition, which of these is a homogeneous mixture?
 - Apple Juice
 - Ice cream
 - Salad
 - Sand

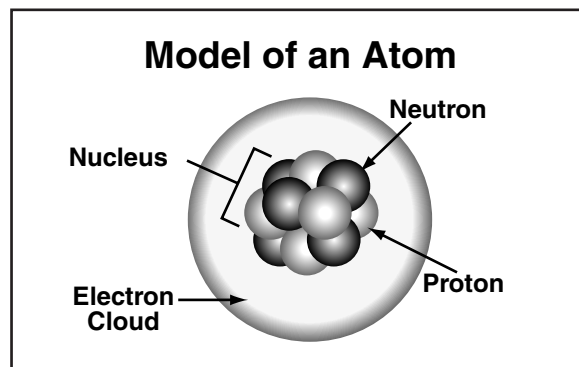
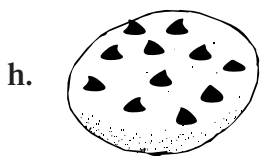
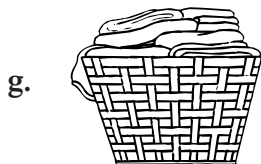
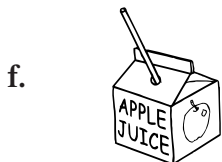

- In which part of the atom are protons located?
 - electron cloud
 - neutron
 - nucleus
 - electron

Characteristics of Some Solids

Solid	Atomic Number	Atomic Mass
Sodium	11	22.99
Potassium	19	39.10
Carbon	6	12.01
Sulfur	16	32.07

- According to this information, which solid has fewer than 10 protons in its nucleus?
 - sodium
 - potassium
 - carbon
 - sulfur

Metal	Aluminum	Copper	Gold	Iron	Silver
Mass Number	27	64	197	56	108

5. The chart shows the mass numbers of some metals. Which of these graphs best represents these data?

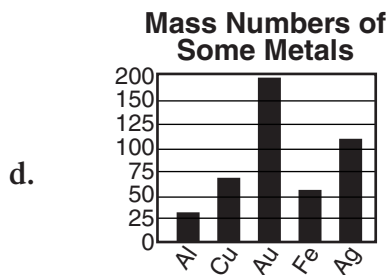
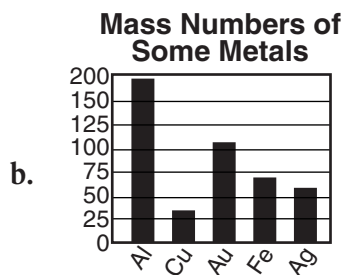
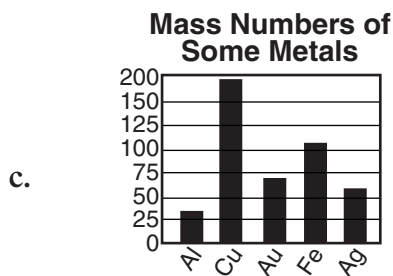
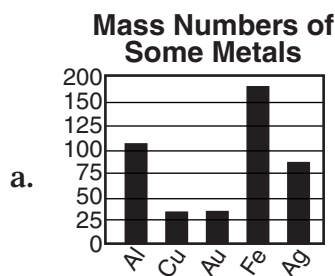

Type of Particle	Particle Charge
Proton	Positive
Neutron	Neutral
Electron	?

6. This chart is being made by a student for a presentation. What type of charge should be filled in beside Electron?
- f. positive
 - g. zero
 - h. negative
 - j. neutral



DIRECTIONS

Read each question. Then, on your answer sheet, mark the answer choice that you think is best.

1 Which statement provides the best description of a homogeneous mixture?

- A** A homogeneous mixture is a mixture that is made very slowly.
- B** A homogeneous mixture always contains a liquid and a solid.
- C** A homogeneous mixture is made by combining many protons.
- D** A homogeneous mixture is a mixture that is the same throughout.

2 Atoms contain one or more positively charged particles in their nucleus. These positively charged particles are called

- F** neutrons
- G** electrons
- H** protons
- J** compounds

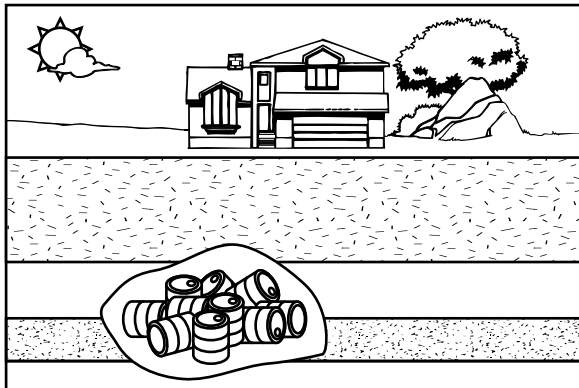

3 What is a necessary part of nuclear waste disposal?

- A** measuring how much waste there is
- B** isolating it from people
- C** planting trees right above it
- D** burning it in a safe place

4 Which of the following would be the best for conducting electricity?

- F** copper
- G** oxygen
- H** wood
- J** paper

5 The isotope carbon-14 is used to determine the age of ancient artifacts by comparing levels of radioactivity. This technique can help archaeologists determine the age of

- A** living fish
- B** rocks
- C** fossils of past organisms
- D** music of previous cultures

6 What causes transmutation to occur through radioactive decay?

- F** An element becomes heavier by gaining protons and neutrons.
- G** An element becomes less stable by releasing energy.
- H** The repulsive forces in the nucleus become large enough to cause the nucleus to become unstable.
- J** Protons are ejected from the electron cloud.

7 Sometimes two elements combine to make a new substance with its own special properties. This new substance is an example of

- A** a homogeneous mixture
- B** a heterogeneous mixture
- C** an atom
- D** a compound

8 Which of the following is not an example of matter?

- F** water
- G** sunlight
- H** air
- J** wood

Isotopes of Hydrogen

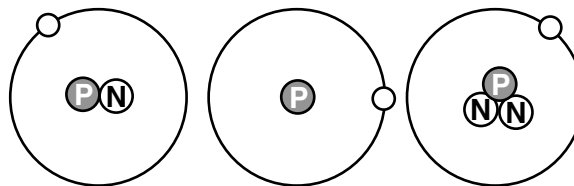

9 Which of these statements is correct?

- A** All isotopes of hydrogen have one proton in the nucleus.
- B** All isotopes of hydrogen have one neutron in the nucleus.
- C** Isotopes of hydrogen have different numbers of electrons in them.
- D** There are the same number of protons and neutrons in every isotope of hydrogen.

Directions: Read Numbers 10–11 below. Then, on the lines that follow, write your answers in complete sentences.

10 All substances have chemical formulas that tell about what is inside them. The chemical formula for water is H_2O . What do the numbers and letters in the chemical formula for water tell about water?

11 Some elements decay by emitting alpha particles. An alpha particle is made up of two protons and two neutrons. Use what you know about the structure of an atom to explain why an element that loses an alpha particle becomes a new element.



DIRECTIONS

Read each question and choose the best answer. Then fill in the correct answer on your answer document.

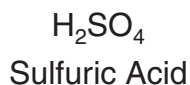

1. According to the chemical formula in the box above, all of the following chemical elements can be found in a molecule of sulfuric acid EXCEPT _____.
- carbon
 - hydrogen
 - oxygen
 - sulfur

Characteristics of Some Elements

Element	Atomic Number	Atomic Mass
Hydrogen	1	1
Helium	2	4
Lithium	3	7
Beryllium	4	9

2. According to the information above, which of the elements has an atomic number that is equal to its mass number?
- Hydrogen
 - Helium
 - Lithium
 - Beryllium

Elements

Element	Number of Protons	Number of Neutrons
Hydrogen	1	0
Carbon	6	6
Oxygen	8	8
Uranium	92	142

3. The mass number of an atom is equal to the number of protons and neutrons in its nucleus. According to this definition, which of the elements in the table has the highest mass number?
- Hydrogen
 - Carbon
 - Oxygen
 - Uranium

**Molecular Masses of
Some Compounds**

Compound	Molecular Mass (atomic mass units)
NaCl	58.8
LiF	25.9
NaBr	102.9
KI	166.0

4. Which of the compounds listed above has the smallest molecular mass?
- f. NaCl
 - g. LiF
 - h. NaBr
 - j. KI

Atomic Mass	Density

5. This chart would most likely be used in an experiment designed to answer which of the following questions?
- a. Does an element's density increase when its temperature is increased?
 - b. Which substances will float on water?
 - c. Does an element's density increase as its atomic mass increases?
 - d. Are solids more dense than liquids?

6. Which of the following is a property of a nonmetal?
- f. It has a hard and shiny surface.
 - g. It can be bent into different shapes.
 - h. It is a poor conductor of electricity.
 - j. It is a good conductor of heat.



DIRECTIONS

Choose the best answer choice for each of the following questions.

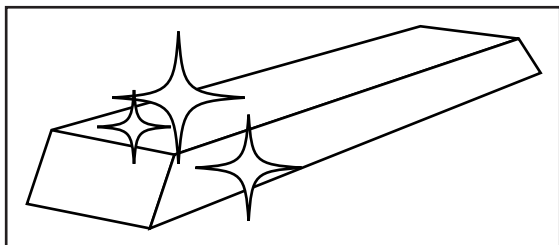

- 1** A chemist analyzed the block shown above and found that it was hard, malleable, and shiny. The block could be made of

A neon
B oxygen
C copper
D chlorine

- 2** Which of the following could best be used to view a sample of a metalloid?

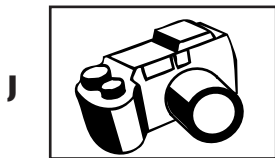
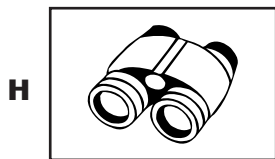
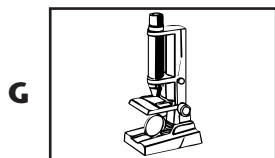
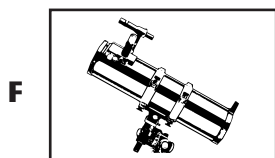

- 3** The periodic table is arranged so that elements having similar chemical and physical properties are arranged vertically in groups. Which of the following scientists is responsible for first arranging the elements into a table with this pattern?

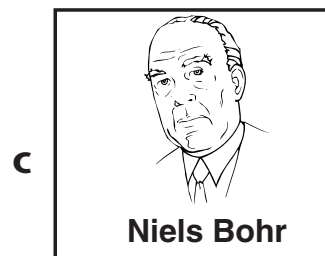
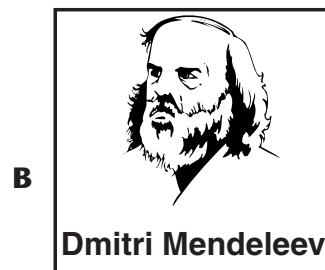
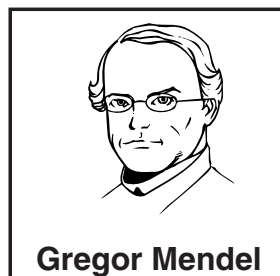

4 The periodic table organizes the basic building blocks of matter. These building blocks are called

- F** elements
- G** molecules
- H** noble gases
- J** compounds

5 Which of the following is not a metal?

- A** iron
- B** calcium
- C** sulfur
- D** nickel

6 Which of the following is not a halogen?

- F** chlorine
- G** helium
- H** fluorine
- J** iodine

7 A chemist performed a series of experiments on an element and found that it did not react with any other element, no matter what the chemist did. The element was most likely

- A** a noble gas
- B** a halogen
- C** an alkaline earth metal
- D** an alkali metal

Directions: Read Numbers 8–9 below. Then, on the lines that follow, write your answers in complete sentences.

8 The maker of the periodic table placed the elements in groups. Describe the criteria he used to place the elements into the groups.

9 The periodic table shows many different groups of elements. Use your understanding of the periodic table to explain the characteristics of one group.



DIRECTIONS

Choose the best answer choice for each of the following questions.

- Which statement best describes the structure of an atom?
 - An atom consists of a neutral center surrounded by a cloud of positive particles.
 - An atom consists of a positive center surrounded by a cloud of negative particles.
 - An atom consists of a negative center surrounded by a cloud of negative particles.
 - An atom consists of a positive center surrounded by a cloud of neutral particles.
- The picture shows a sodium atom and its various energy levels filled with the appropriate number of electrons. According to this picture, which energy level has electrons available for bonding?
 - Nucleus
 - Level 1
 - Level 2
 - Level 3
- Under which heading in a table of contents would information about elements with eight electrons in their outer level be found?
 - Alkali Metals
 - Halogens
 - Noble Gasses
 - Isotopes
- All of the following are ways in which atoms can form bonds with other atoms EXCEPT _____.
 - losing electrons
 - sharing electrons
 - sharing neutrons
 - gaining electrons
- An ionic bond forms between a metal and a nonmetal. According to this information, which of the following pairs of elements could form an ionic bond?
 - two atoms of hydrogen
 - an atom of carbon and an atom of oxygen
 - an atom of magnesium and an atom of oxygen
 - an atom of lithium and an atom of calcium

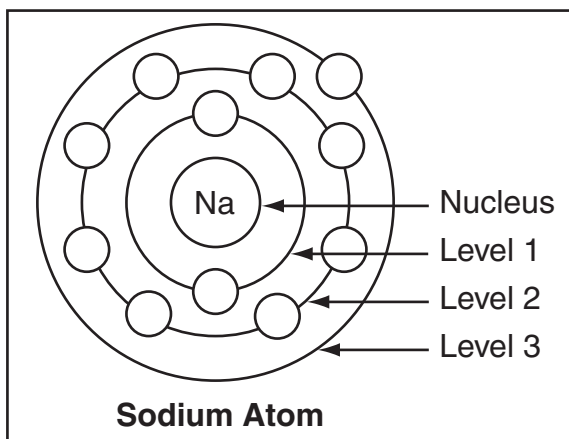

Bonding Electrons Available for Some Elements

Element	Number of Bonding Electrons
Calcium	2
Boron	3
Oxygen	6
Potassium	1

6. The number of bonding electrons an element has determines the chemical properties of that element. According to this information, which of the following is most likely to have properties similar to boron?

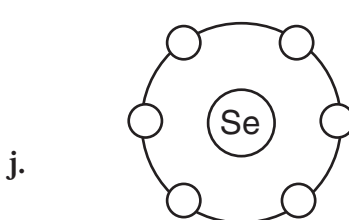
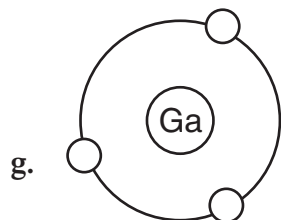
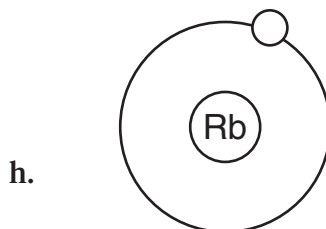
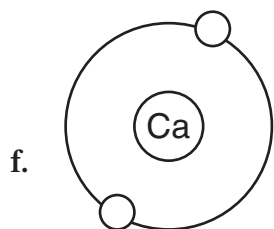

7. Which of the following is a major characteristic of the halogen family?
- elements with seven electrons in their outer level
 - elements with eight electrons in their outer level
 - elements with nine electrons in their outer level
 - elements with eleven electrons in their outer level



DIRECTIONS

Read each question. Then, on your answer sheet, mark the answer choice that you think is best.

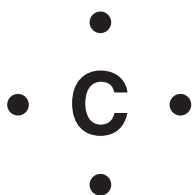

- 1** The illustration above shows a way of representing
- A** the number of electrons carbon has
 - B** the number of bonding electrons carbon has
 - C** the number of protons carbon has
 - D** the number of neutrons carbon has
- 2** Covalent bonds occur between nonmetals that share electrons. Which of the following is not an example of covalent bonding?
- F** two bonded chlorine atoms
 - G** an atom of carbon bonded to oxygen
 - H** an atom of magnesium bonded to sulfur
 - J** an atom of carbon bonded to hydrogen
- 3** Chet discovers a new element and wants to know where to place it in the periodic table. He notes that the element has the same number of bonding electrons as neon, a noble gas. He also sees it is the same color as bromine, a halogen. He should identify the substance as
- A** a metal
 - B** a solid
 - C** a halogen
 - D** a noble gas
- 4** Which of the following is a true statement regarding bond formation?
- F** Each atom becomes more stable after bonding.
 - G** Only one atom becomes more stable after bonding.
 - H** Each atom loses an energy level after bonding.
 - J** Only one atom loses an energy level after bonding.

5 A compound is a substance that contains two or more elements. According to this definition, which of these formulas represents a compound?

- A** Li
- B** Br₂
- C** NaCl
- D** 3O₂

6 Electrons surrounding an atom generally are represented as a fuzzy cloud of particles. Why do scientists represent electrons in this way?

- F** The electrons are moving too fast to draw.
- G** It is not possible to know the exact position of any given electron.
- H** Scientists do not know if electrons actually surround an atom.
- J** The electrons are not actually particles but are really gas molecules.

Directions: Read Number 7 below. Then, on the lines that follow, write your answer in complete sentences.

7 The periodic table is arranged in a very specific way. The arrangement of the elements into vertical columns, or groups, allows us to predict certain physical and chemical properties of those elements. Give examples of two different groups within the periodic table, and describe some properties common to the elements in those groups.



DIRECTIONS

Choose the best answer choice for each of the following questions.

Formulas of Some Common Chemicals

Common Name	Chemical Formula
Hydrogen Peroxide	H ₂ O ₂
Carbon Dioxide	CO ₂
Ozone	O ₃
Vinegar	CH ₃ CO ₂ H

- According to this information, which chemical has more than two atoms of oxygen?
 - hydrogen peroxide
 - carbon dioxide
 - ozone
 - vinegar
 - Information about chemical reactions that release energy most likely would be found under which category in a textbook?
 - endothermic
 - exothermic
 - electrolysis
 - activation energy
- $$\text{Zn} + \text{Ag}_2\text{S} \rightarrow \text{ZnS} + ?\text{Ag}$$
- All chemical equations follow the law of conservation of mass. Which number should be used in place of the question mark to balance this equation?
 - 1
 - 2
 - 0
 - 4
 - Jeff was trying to determine if his experiment had undergone a physical or chemical change. Which observation could mean that it was NOT a chemical change?
 - Something was burning.
 - Gas and bubbles were created.
 - The temperature changed.
 - The colors of the reactants mixed.
 - In general, catalysts affect reactions most by _____.
 - decreasing the reactants
 - increasing the products
 - increasing the reaction rate
 - decreasing the reaction rate

6. Which molecule would be described in a glossary as a catalyst in the bodies of living things?

- f. reactant
- g. product
- h. inhibitor
- j. enzyme

CHEMICAL EQUATION	ENERGY	PRODUCTS
-------------------	--------	----------

7. Which of these belongs with the group above?

- a. Particle size
- b. Mass
- c. Reactant
- d. Rust

8. A scientist has observed the effects of a catalyst on the rate of a reaction. Which of the following graphs most likely best represents the effects of the catalyst on the rate of reaction?

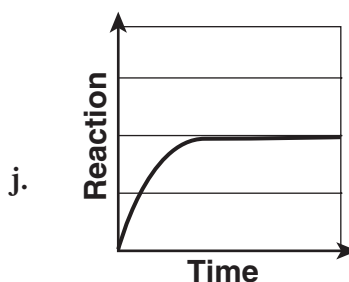
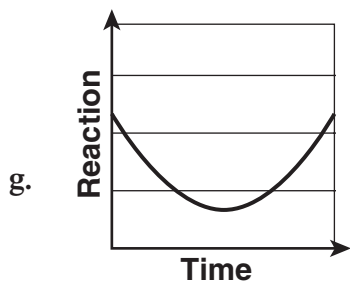
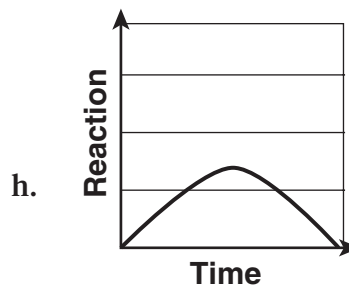
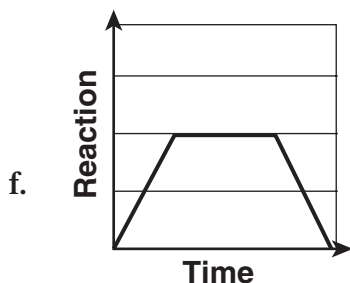

DIRECTIONS

Read each question. Then, on your answer sheet, mark the answer choice that you think is best.

- 1** Which of the following would not be considered a chemical reaction?
- A** a metal rusts
 - B** a magazine is torn
 - C** food is digested
 - D** firewood is burned
- 2** Which of these would you expect to have an effect on the rate of a chemical reaction?
- F** the shape of the container
 - G** the time of day
 - H** a change in temperature
 - J** the type of equipment used
- 3** The larger the surface area of reactants, the faster a reaction takes place. Which of these reactants burns the fastest?
- A** large thick log
 - B** several long branches
 - C** old tree stump
 - D** many small thin twigs
- 4** Which of the following would result in a decreased rate in a chemical reaction?
- F** addition of an inhibitor
 - G** addition of a catalyst
 - H** increase in the temperature of the reactants
 - J** increase in the concentration of the reactants
- 5** Theresa was observing a chemical reaction and concluded it was exothermic. What observation probably led Theresa to this conclusion?
- A** The final products were colder than the reactants.
 - B** The final products were warmer than the reactants.
 - C** The chemical reaction had occurred quickly.
 - D** The chemical reaction had occurred slowly.

Directions: Read Numbers 6–7 below. Then, on the lines that follow, write your answers in complete sentences.

- 6** All foods contain bacteria that can be potentially harmful if too much of it grows in the food. Warmer temperatures increase the rate at which bacteria grow. What are some ways of limiting the growth of bacteria in our food?

- 7** Most reactions need a certain amount of energy to begin. Design an experiment to compare various reactions in our daily lives to determine which need the most energy to begin.



DIRECTIONS

Choose the best answer choice for each of the following questions.

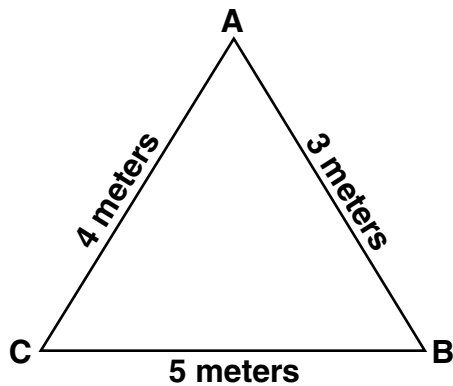

- Jason walks from Point A to Point B. Then he walks to Point C and finally back to Point A. According to this information, which of the following represents Jason's displacement?
 - 12 meters
 - 9 meters
 - 0 meters
 - 7 meters
- A car accelerates from 10 meters per second to 20 meters per second in 5 seconds. Which of the following represents the car's acceleration?
 - 2 m/s^2
 - 20 m/s^2
 - 10 m/s^2
 - 0.2 m/s^2
- Which statement best describes the difference between speed and velocity?
 - Speed is distance divided by time, and velocity is total distance.
 - Speed is how fast an object is moving, and velocity includes speed and direction.
 - Velocity is how fast an object is moving, and speed includes speed and direction.
 - Speed and velocity are in units of meters per second.

Bay School Runners

Name	Distance	Time
David	200 meters	20 seconds
Jolene	100 meters	10 seconds
Pooja	300 meters	20 seconds
Henry	100 meters	20 seconds

- According to this information, which runner had a speed of 15 m/s ?
 - David
 - Henry
 - Jolene
 - Pooja

Object	Mass	Velocity
Runner	70 kg	4.0 m/s north
Car	1500 kg	20 m/s south
Football player	100 kg	8.5 m/s west
Truck	2500 kg	2 m/s east

5. According to this information, which object has the greatest momentum?
- runner
 - car
 - football player
 - truck
6. A blue billiard ball is approaching an orange billiard ball. If all other factors are equal, the collision would be called inelastic if _____.
- the balls bounce off one another
 - the balls move at different speeds
 - the blue ball rolls off in one direction, and the orange ball rolls off in another direction
 - the balls stick together and roll off as one
7. An object with a mass of 1 kg moving at a speed of 2 m/s has a head-on collision with another object with a mass of 1 kg moving at a speed of 2 m/s. What is the total momentum before the collision?
- 0
 - $2 \text{ kg} \cdot \text{m/s}^2$
 - $4 \text{ kg} \cdot \text{m/s}^2$
 - $6 \text{ kg} \cdot \text{m/s}^2$
8. Which of the following is the LEAST important consideration when calculating velocity?
- mass
 - direction
 - distance
 - time
9. Which of the following is a major characteristic of a collision?
- One object hits another, and they both lose momentum as a result.
 - One object hits another, and they both gain momentum as a result.
 - One object hits another, but momentum is conserved.
 - One object hits another, and only one object conserves momentum.
10. Which of these quantities does NOT involve direction?
- velocity
 - speed
 - acceleration
 - momentum



DIRECTIONS

Read each question. Then, on your answer sheet, mark the answer choice that you think is best.

- 1** Two space satellites collide and stick together. Which of these statements is true?
- A** Their total momentum is the same.
 - B** Their combined velocity is zero.
 - C** Their combined mass is zero.
 - D** Their combined mass is less than before.

Directions: This graph shows Emilio's speed as he walked to school. Use the information in the graph to answer Numbers 2–3 below.

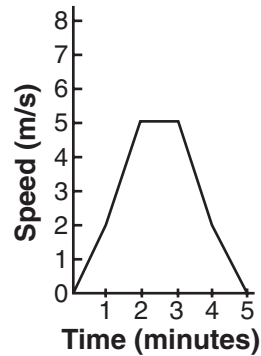

- 2** The time interval on the graph when Emilio was not accelerating is
- F** from 0 minutes to 2 minutes
 - G** from 2 minutes to 3 minutes
 - H** from 4 minutes to 5 minutes
 - J** from 1 minute to 5 minutes
- 3** During the time interval between 4 and 5 minutes, Emilio slowed down. This type of acceleration is called
- A** positive
 - B** reverse
 - C** negative
 - D** forward

4 Which of these represents the formula for calculating momentum?

- F** distance traveled/time
- G** final speed initial speed/time
- H** mass \times velocity
- J** mass \times time

5 Malcolm's teacher tells him that when two billiard balls collide, their total momentum doesn't change. Which law supports his teacher's statement?

- A** the law of conservation of collision
- B** the law of conservation of mass
- C** the law of conservation of velocity
- D** the law of conservation of momentum

Directions: Read Number 6 below. Then, on the lines that follow, write your answer in complete sentences.

6 Two different types of collisions exist in nature, elastic and inelastic. Give an example of each, and explain the similarities and differences between the two.



DIRECTIONS

Choose the best answer choice for each of the following questions.

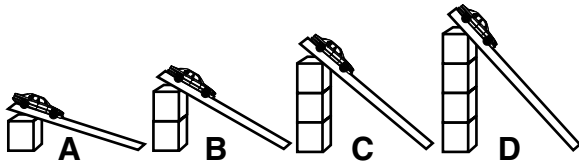

- The picture above shows four identical toy cars at the tops of four different ramps. When all of the toy cars are pushed down the ramps with the same force, which toy car will travel the farthest from the bottom of its ramp?
 - A
 - B
 - C
 - D

- All of these pictures show unbalanced forces EXCEPT ____.

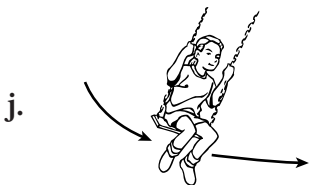
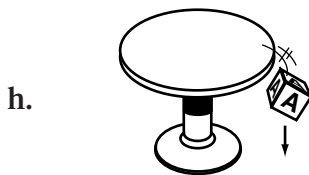
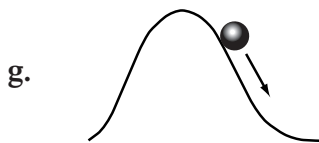
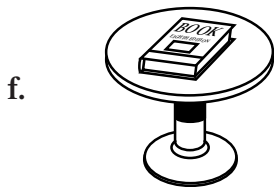

- This picture shows a girl holding a ball. According to this picture, what is exerting a force on the ball?
 - only rolling friction
 - only magnetism
 - the girl and gravity
 - only gravity

- Which of these seesaws is most likely to tip to the left?

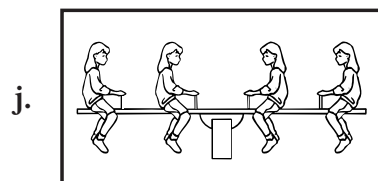
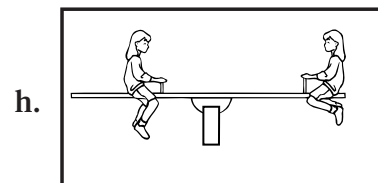
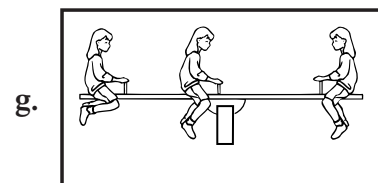
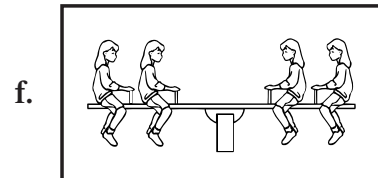

5. Acceleration occurs whenever an object speeds up, slows down, or changes the direction in which it is moving. According to this definition, all of these are examples of acceleration EXCEPT _____.

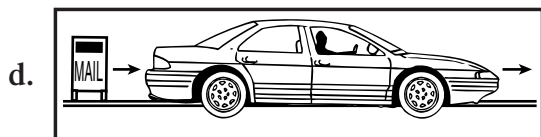
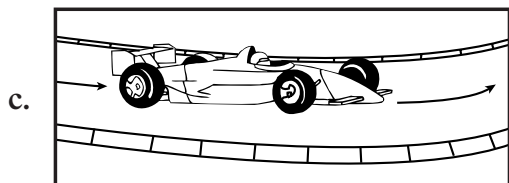
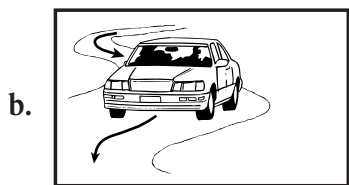
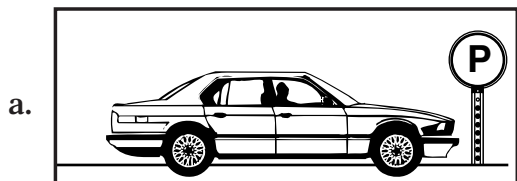

Type	Description
Static friction	the force that prevents an object from moving when it is first pushed
Sliding friction	the force that slows down a sliding object
Rolling friction	the force that pushes back on a rolling object
Air resistance	the force that slows down an object moving through the air

6. According to the chart, an airplane in flight is acted on by _____.

- f. static friction
- g. sliding friction
- h. rolling friction
- j. air resistance

7. What is the purpose of using a parachute when skydiving?

- a. To create an upward force of air resistance and slow down
- b. To reduce the friction force and speed up
- c. To go faster than terminal velocity
- d. To balance out the forces and stop the skydiver from moving

8. Friction is the force that occurs when a moving object rubs against another surface, slowing it down. According to this definition, in which picture will the ball have the most friction acting on it?

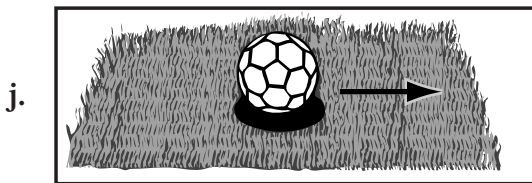
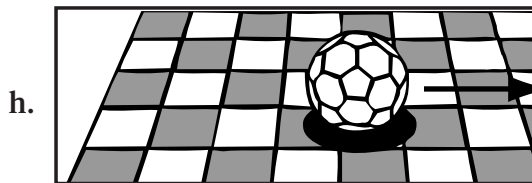
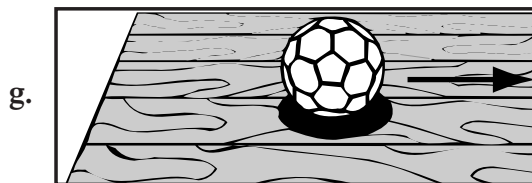
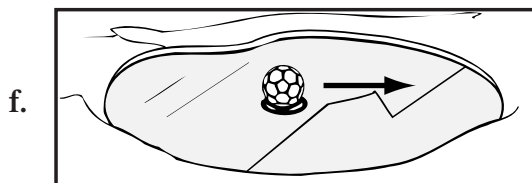

DIRECTIONS

Read each question. Then, on your answer sheet, mark the answer choice that you think is best.

A group of students is studying the way balls move down ramps. You can see their experiment right here! Use the information in the pictures and the table to answer Numbers 1–2 below.

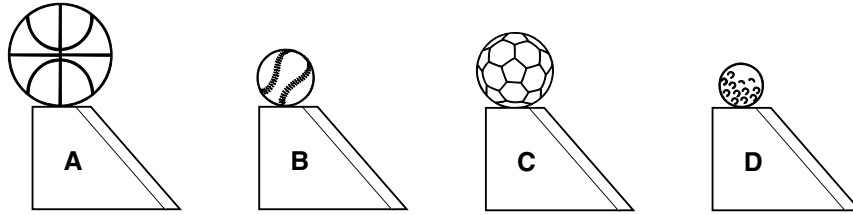

Ball	Trial 1	Trial 2	Trial 3
Ball A	130 cm	135 cm	132 cm
Ball B	90 cm	89 cm	95 cm
Ball C	120 cm	129 cm	127 cm
Ball D	150 cm	148 cm	159 cm

- 1** Which ball traveled farthest once it got to the bottom of the ramp?

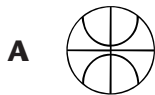

- 2** Suppose the heights of the ramps are raised, and the balls roll down the ramps and roll along the floor. The increase in the heights of the ramps will most likely make

- F** the balls roll farther from the bottom of the ramp
G the balls stop at the bottom of the ramp
H the balls stop sooner after they get off the ramp
J the baseball go the farthest

- 3** When a person pushes on a wall, why doesn't the wall fall over?
- A** The wall cannot exert a force on anything.
 - B** The wall is pushing back with the same force.
 - C** The wall is pulling on the person.
 - D** The forces are not balanced enough.

- 4** Jamal, a professional bicycle racer, is explaining to a group of students how technology has made it easier to cycle faster. He states that bicycles can be made of much lighter materials now, so they need
- F** more force to push them forward
 - G** less force to push them forward
 - H** more friction to keep them from rolling
 - J** more gravity to increase their speed

Directions: Read Numbers 5–6 below. Then, on the lines that follow, write your answers in complete sentences.

- 5** Marcia is a skydiver who jumps out of a plane. She falls very quickly for a couple of seconds. Then she opens her parachute and her speed decreases to a slower, steady rate until she reaches the ground. Explain what a force is and what forces were acting on Marcia during her jump.

- 6** Newton's Third Law says that for every action there is an equal and opposite reaction. Jason is thinking about this as he walks home from school. What action-reaction forces are acting to make Jason's feet move forward as he walks?



DIRECTIONS

Choose the best answer choice for each of the following questions.

1. Work is only done when the force exerted on an object is in the same direction as the object's motion. According to this definition, which of these illustrates work being done?

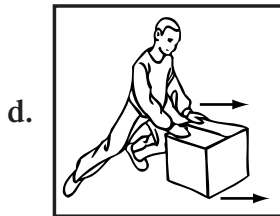
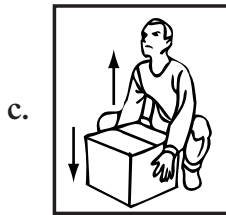
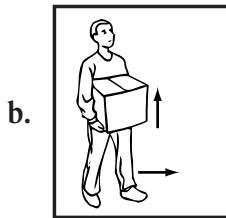
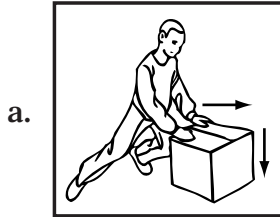

2. All of these are simple machines EXCEPT _____.

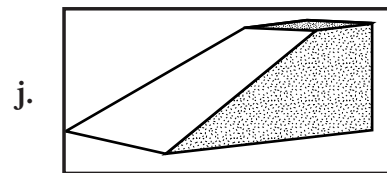
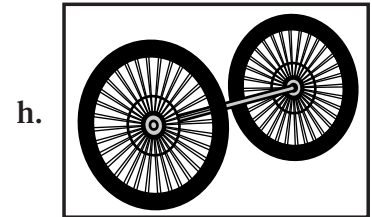
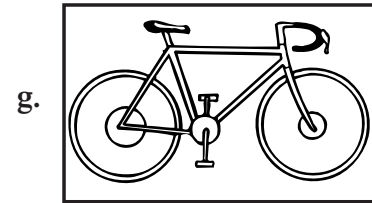
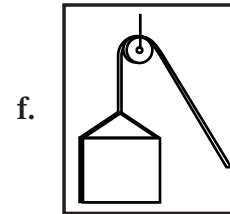

3. What is one way in which simple machines make work easier?
- improving the quality of axles used in cars
 - eliminating the need for workers to apply any force when completing tasks
 - decreasing the amount of force necessary to complete a task
 - creating the need for more workers

Friction/Machine Efficiency Relationship

Trial	Amount of Friction Applied	Efficiency of Machine (%)
1	none	100
2	low	85
3	medium	70
4	high	55

4. The table above shows the relationship between a machine's efficiency and the effects of friction. A reasonable hypothesis based on these data is that if the amount of friction applied increases, then _____.
- the machine's efficiency will increase
 - the machine will become completely inefficient
 - the work completed by the machine will increase
 - the machine's efficiency will decrease

5. What is the purpose of increasing the length and thinness of a wedge?
- to decrease the distance over which a force needs to be applied
 - to make the wedge lighter and easier to carry
 - to increase the mechanical advantage
 - to help the wedge to stay clean and well-lubricated
6. Under which heading in a table of contents would the most information about inclined planes be found?
- Form and Function of a Hockey Stick
 - Egyptian Ramps
 - Expert Use of Sailing Pulleys
 - The Force of a Softball Pitch



DIRECTIONS

Read each question. Then, on your answer sheet, mark the answer choice that you think is best.

- 1** One way to evaluate the effectiveness of a simple machine is by computing the ratio of output force to input force. This ratio is called the

A mechanical advantage
B machine proportion
C motive force
D utility fraction

- 2** Which of the following is not an important consideration when calculating work?

F Motion
G Distance
H Efficiency
J Force

- 3** The measure of work done in a specific amount of time is known as

A force
B power
C energy
D time

- 4** Which of these would most likely make a screw easier to use?

F Increasing the length of its thread
G Decreasing the length of its thread
H Increasing its width
J Decreasing its width

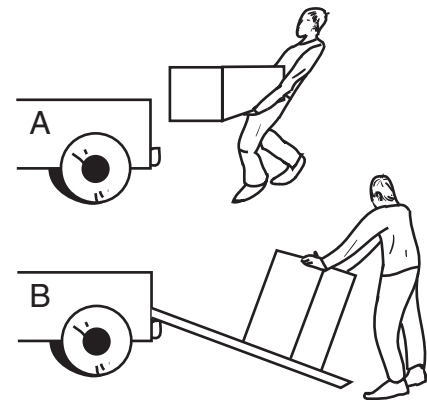

- 5** Which statement is accurate?

A Simple machines make work easier to do, even though the amount of work actually done is the same.
B Simple machines make work easier to do by decreasing the amount of work done.
C Simple machines make work harder to do by increasing the amount of work done.
D Simple machines do not affect the perceived difficulty level of work.

6 A scientist measured the amount of work done by a series of simple machines. The work the scientist recorded was most likely measured in

- F** joules
- G** centimeters
- H** seconds
- J** kilograms



7 As Keshia picks the cat up from the floor, her arms

- A** act as a type of inclined plane
- B** apply a force perpendicular to the direction of lift
- C** do work against gravity
- D** exert power on the cat

Directions: Read Numbers 8–9 below. Then, on the lines that follow, write your answers in complete sentences.

8 A student is studying a wheel and axle. The student finds that the radius of the wheel is 14 centimeters and the radius of the axle is 2 centimeters. Using this information, find the mechanical advantage of the wheel and axle. Show your work.

9 A construction worker is using a pulley system to move large, heavy objects. The construction worker does 200 Joules of work, and the pulley system has a work output of 170 Joules. Using this information, find the efficiency of the pulley system. Show your work.



DIRECTIONS

Choose the best answer choice for each of the following questions.

- When you walk across a cold floor with bare feet, your feet become cold. Which of these is the most likely cause of your feet becoming cold?
 - Thermal energy always moves from warmer to cooler objects.
 - Thermal energy always moves from cooler to warmer objects.
 - The floor absorbs fast-moving electrons from your feet.
 - Your feet absorb colder molecules from the floor.

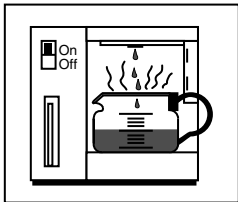
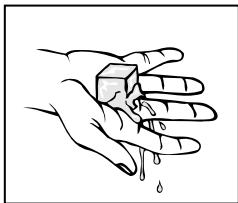
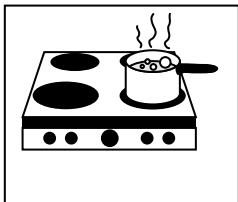

- Which process is taking place in all three pictures?
 - radiation
 - convection
 - conduction
 - forced convection

- Which of these causes the temperature of a heated pot of water to increase?
 - an increase in the potential energy of water molecules
 - an increase in the kinetic energy of water molecules
 - extra electrons absorbed by the water molecules
 - metal atoms from the pot absorbed by the water molecules
- All of the following are types of temperature scales EXCEPT _____.
 - Fahrenheit
 - kelvin
 - Celsius
 - mercurial

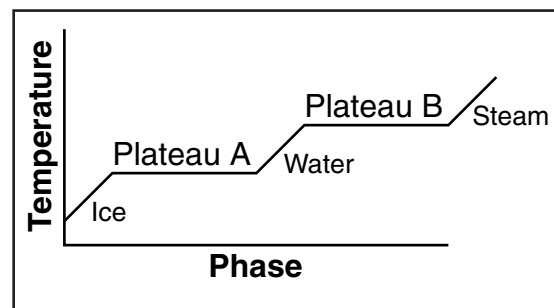

- Plateau A on the graph represents the point when the water is changing from a solid to a liquid. According to the graph, what type of phase change is occurring at Plateau B?
 - condensation
 - fusion
 - vaporization
 - sublimation

6. Most engines will have all of these properties EXCEPT the ability to _____.
- f. convert thermal energy into mechanical energy
 - g. convert chemical energy into thermal energy
 - h. transfer excess energy to a cooler area
 - j. use energy to perform work
7. In new houses, heating systems are often built right into the structure of the house itself. Which of the following is the best place for a heating system in a house?
- a. the floor, because heat rises
 - b. the ceiling, because heat falls
 - c. the walls, because the more surface covered, the more heat given off
 - d. the doors, because the best place to add heat is where the heat gets lost
8. Which of the following is a major characteristic of radiation?
- f. thermal energy that is transferred by direct contact
 - g. thermal energy that is transferred by electromagnetic waves
 - h. thermal energy that is transferred by the movement of heated particles
 - j. thermal energy that is transferred by the movement of forced particles
9. Marissa and her science partner are working in their school's science lab. Marissa's partner shows her a thermometer that was heated to 100°C. Marissa knows that this thermometer most likely just read the temperature of _____.
- a. a glass of milk
 - b. a bowl of still water
 - c. a pot of boiling water
 - d. a melting ice cube
10. Under which heading in a table of contents would information about viscosity most likely be found?
- f. Why Water Expands When It Is Frozen
 - g. The Properties of Coolants
 - h. Conversions Between the Celsius Scale and the Kelvin Scale
 - j. Why Molasses Flows Slowly and Water Flows Quickly
11. The efficiency of a machine is calculated using _____.
- a. the ratio of work in to work out
 - b. the ratio of work out to work in
 - c. the product of work out and work in
 - d. the difference between work out and work in



DIRECTIONS

Read each question. Then, on your answer sheet, mark the answer choice that you think is best.

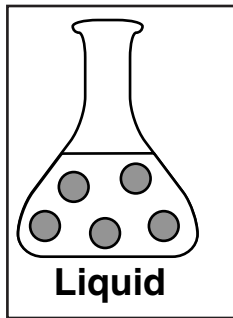

- 1** Which of the following is not a true statement about the liquid?
- A** The liquid takes the shape of its container.
 - B** The water molecules can move past one another.
 - C** If poured into a larger beaker, the volume of the liquid would increase.
 - D** The water molecules have enough kinetic energy to overcome some attractive forces.
- 2** Which of these makes certain materials good thermal conductors?
- F** valence electrons
 - G** protons
 - H** thermal convection
 - J** neutrons
- 3** There are several different types of heat transfer. The type of heat transfer that uses electromagnetic waves to increase thermal energy is called
- A** convection
 - B** radiation
 - C** conduction
 - D** thermal magnetics
- 4** Which statement provides the best description of the specific heat of a substance?
- F** Specific heat is the amount of heat needed to cool a substance to a specific, low temperature.
 - G** Specific heat is the temperature at which the substance condenses.
 - H** Specific heat is the amount of molecules needed to raise the temperature.
 - J** Specific heat is the amount of heat needed to raise the temperature of 1 kg of a substance 1°C.

5 In which of the following would you expect to find the most kinetic energy?

- A** a cup of milk
- B** helium inside a balloon
- C** a block of ice
- D** water inside a balloon

6 Snowflakes melt on your tongue because

- F** heat from your tongue condenses the water molecules
- G** faster-moving water molecules in the snow collide with slower-moving molecules on your tongue
- H** faster-moving molecules in the snow on your tongue collide with the slower-moving water molecules in the snow
- J** heat from your tongue sublimates the water molecules

Directions: Read Number 7 below. Then, on the lines that follow, write your answer in complete sentences.

7 Describe how you would demonstrate the different phases water experiences as it goes from a solid to a gas. Make sure you tell what is happening to the molecules at each stage as more and more thermal energy is applied.



DIRECTIONS

Choose the best answer choice for each of the following questions.

- If you want to demonstrate that like charges repel, it would be best to _____.
 - place two positively charged objects near each other
 - place two neutral objects near each other
 - place one positive and one negative object near each other
 - place one negative and one neutral object near each other

Conductors	Semiconductors	Insulators
silver	silicon	wood
copper	germanium	glass
aluminum		rubber

- The table above compares the conductivity of several materials. Which of these materials should you use to prevent electrons from flowing easily?
 - germanium
 - wood
 - silver
 - copper

$$I = V/R$$

- This equation shows Ohm's law, which says current is equal to voltage divided by resistance. In what units is electrical current measured?
 - tesla
 - joules
 - ohms
 - amperes



- If lightning strikes this house, the lightning rod on top will prevent damage because _____.
 - an electrical charge is not able to move through the rod
 - the rod is an insulator and cannot receive an electrical charge
 - the excess electrical charge will be conducted into the ground
 - the rod will convert the excess electrical charge into air

5. Which of the following factors would have the LEAST effect on a battery's ability to power a portable radio?
- the voltage of the battery
 - the battery's ability to separate charges
 - the resistance inside the battery
 - the shape of the battery

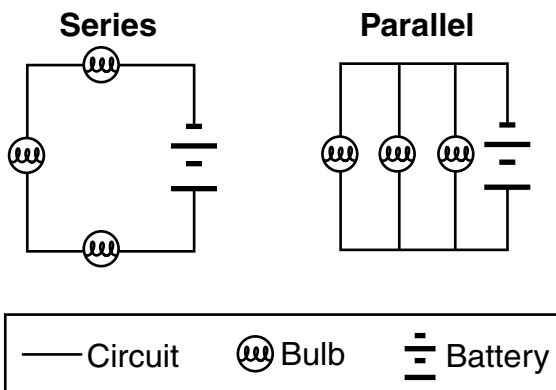

6. These boxes show two ways of connecting a circuit. The series circuit differs from the parallel circuit because the lights in the series circuit all experience _____.
- the same current
 - the same voltage
 - different current
 - alternating current

7. According to Ohm's Law, if the voltage in a battery is increased, what will happen to the current produced by the battery?
- It will increase.
 - It will decrease.
 - It will stay the same.
 - It is impossible to determine.
8. Which of these describes charge?
- the power of a body to create energy through movement
 - a measure of the weight of a body
 - the ability of a body to influence other charges around it
 - the amount of matter in a body
9. How can the electron flow in a wire be increased?
- changing the color of the wire
 - decreasing the length and increasing the width of the wire
 - increasing the length and decreasing the width of the wire
 - changing the direction of the wire



DIRECTIONS

Read each question. Then, on your answer sheet, mark the answer choice that you think is best.

- 1** Darnell wants to know what charge a piece of cloth has. He notes that when it is near a positively charged object, it attracts the object. The cloth also repels a negatively charged object. He should classify the charge of the cloth as

A negative
B neutral
C positive
D uncharged

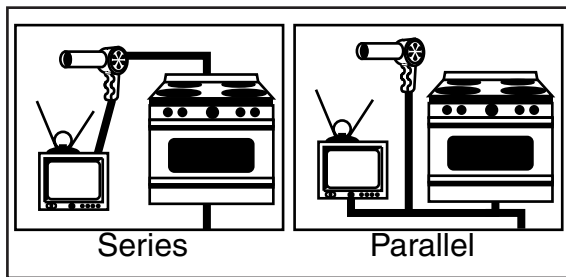

- 2** These boxes illustrate two different ways of setting up a circuit. Which of the following describes the best way to wire these elements in a home?

F The parallel circuit is best because the current is branched.
G The series circuit is best because the current is unbranched.
H The parallel circuit is best because each element reduces the current.
J The series circuit is best because each element increases the current.

- 3** Which of these describes voltage?

A a measure of an electron's amperes
B the power delivered by an appliance
C a measure of electrical potential energy
D the amount of resistance present in a circuit

- 4** Some materials do not conduct electricity as well as others. Materials that do not allow free movement of electrons are called

F conductors
G insulators
H electroscopes
J inducers

Power Requirements for Household Appliances

Appliance	Power (in watts)
Coffee maker	1,625
Blender	800
Toaster	950
Microwave	625

- 5** In the table shown above, the appliance that draws the most current is the

A microwave
B blender
C coffee maker
D toaster

6 Electric charges that are not touching can still exert an influence on one another. What explains this phenomenon?

- F** static charge
- G** electric field
- H** induced charge
- J** electric current

7 In a circuit that includes bulbs, the bulbs

- A** reduce the current
- B** replenish the current
- C** keep the current flowing at a constant rate
- D** cool the circuit

Directions: Read Numbers 8–9 below. Then, on the lines that follow, write your answers in complete sentences.

8 Describe an experiment that compares and contrasts series and parallel circuits.

9 Using a piece of fur and a glass rod, describe how you might provide a charge to the rod. Use the word “electron” in your answer.



DIRECTIONS

Choose the best answer for each of the following questions.

- Kenya wanted to observe the properties of two magnets. She placed the ends of the magnets next to one another and watched what happened. Which observation would she most likely NOT make while working with the magnets?
 - The north end of one magnet would repel the south end of the other magnet.
 - The north end of one magnet would attract the south end of the other magnet.
 - The south end of one magnet would repel the south end of the other magnet.
 - The north end of one magnet would repel the north end of the other magnet.
- Which of these causes a magnetic field to be produced around a current-carrying wire?
 - the magnetic domains moving in the wire
 - the metal atoms in the wire
 - the kinetic aurora moving in the wire
 - the electrons moving in the wire

- Bacteria that use Earth's magnetic field to navigate are called magnetostatic bacteria. Which of these is the most likely reason why magnetostatic bacteria can use Earth's magnetic field to navigate?
 - The bacteria have an internal electromagnet.
 - The bacteria contain magnetite.
 - The bacteria have their own magnetosphere.
 - The bacteria use a transformer to interpret magnetic fields.

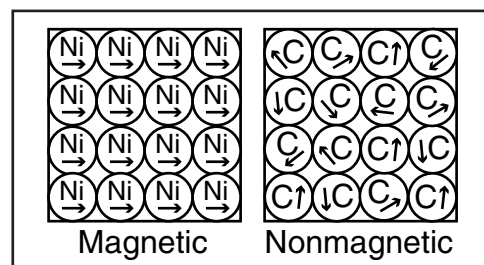

- According to the diagram, which statement best describes why the nickel is magnetic and the carbon is not?
 - The protons in the carbon have their magnetic fields aligned.
 - The protons in the nickel have their magnetic fields aligned.
 - The electrons in the nickel have their magnetic fields aligned.
 - The electrons in the carbon have their magnetic fields aligned.

5. What is the purpose of using a generator?
- to turn motion into electricity
 - to turn electrical energy into kinetic energy
 - to turn motion into magnetism
 - to generate a magnetosphere

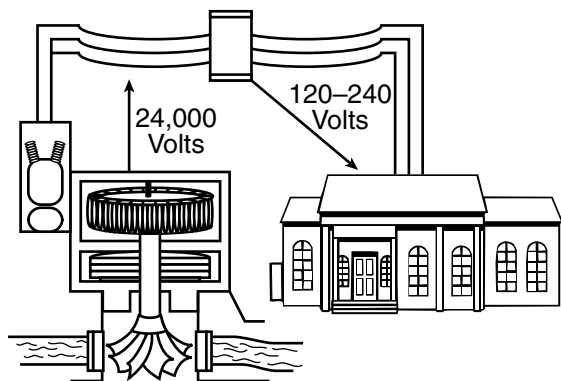

6. The picture shows how homes get electric power from the power plant. The voltage from the power plant is too high to be directly delivered to the house. When the voltage reaches the second set of power lines, what device changes the voltage to 120 or 240 volts?
- electromagnet
 - transformer
 - motor
 - voltmeter

7. Auroras are caused by _____.
- charged particles from the Sun that are deflected by the magnetosphere
 - a magnetic field from the Sun that is deflected by charged particles in Earth's magnetosphere
 - charged particles in Earth's atmosphere that collide with charged particles from the Sun
 - charged particles trapped in the magnetosphere that collide with Earth's atmosphere
8. Mickua wants to demonstrate that north ends of two magnets repel each other. In order to demonstrate this, it would be best for Mickua to _____.
- place the north ends of the two magnets near each other
 - place the north end of one magnet near the south end of another
 - place the north end of one magnet near an unmagnetized object
 - place the north ends of each magnet in an electric field
9. Which of the following is a description of the magnetosphere?
- an electric field around Earth that extends into space
 - electric currents from space that have increased the magnetic field of Earth's iron core
 - a magnetic field around Earth that is strong enough to magnetize Earth's iron core
 - a magnetic field around Earth that is created by Earth's iron core and that extends into space



DIRECTIONS

Read each question. Then, on your answer sheet, mark the answer choice that you think is best.

1 Which of the reasons below explains how magnets can attract or repel objects without touching?

- A** The gravitational force surrounding each magnet acts at a distance.
- B** The magnetic field surrounding each magnet acts at a distance.
- C** The magnets share electrons and act at a distance.
- D** The magnets generate static electricity.

2 Earth generates its own magnetic field. This field is called the

- F** electromagnet
- G** electromotive force
- H** magnetosphere
- J** biosphere

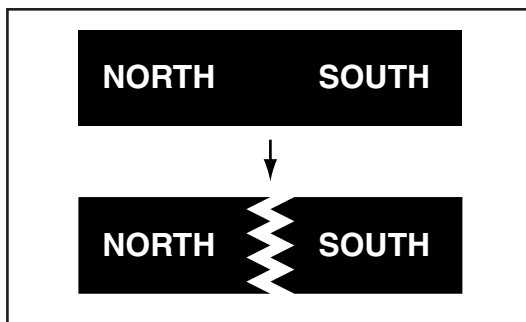

3 Which of these statements is false?

- A** The north and south poles of the magnet will attract each other.
- B** If the magnet is broken in half, it will not have north and south poles.
- C** The south poles of the magnet will repel each other.
- D** If the magnet is broken in half, it will still have north and south poles.

4 When the current to a wire is shut off, the magnetic field around the wire will probably

- F** disappear around a part of the wire
- G** continue to exert a force
- H** disappear completely
- J** attract iron filings

5 Which of the following would help hikers find their way in the woods?

- A** ammeter
- B** transformer
- C** generator
- D** compass

6 In the United States, a type of current is used that varies from positive to negative 60 times per second. This type of current is called

- F** direct current
- G** alternating current
- H** variable current
- J** simulating current

Standardized Test Practice Chapter 23 Magnetism

- 7** A current-carrying wire produces a magnetic field. When this wire is wrapped around an iron core, the magnetic field produced is different than the magnetic field produced by the wire alone because it
- A** is stronger than the magnetic field produced by the wire alone
 - B** is weaker than the magnetic field produced by the wire alone
 - C** cancels out the magnetic field produced by the iron core
 - D** cancels out the magnetic field produced by the wire alone

- 8** Giovanni sprinkled iron filings around a magnet. Which of the following did Giovanni most likely see?
- F** the iron filings lining up against the magnetic field lines
 - G** the iron filings lining up with the magnetic field lines
 - H** the iron filings accumulating atop the magnet
 - J** the iron filings randomly falling around the magnet

Directions: Read Number 9 below. Then, on the lines that follow, write your answer in complete sentences.

9 Explain the basic principle of a generator.



DIRECTIONS

Read each question and choose the best answer. Then fill in the correct answer on your answer document.

1. Carmen is watching a fireworks display with her parents. She notices that she sees the flashes of light before she hears the explosion. This happens because _____.
- the light from the fireworks travels faster than the sound from the explosion
 - the sound from the explosion travels faster than the light from the fireworks
 - Carmen sees better than she hears
 - the fireworks are moving away from Carmen



2. Which of these processes enables the boy to see over the wall?
- Diffraction
 - Interference
 - Reflection
 - Refraction

3. Which sound would have the highest pitch?

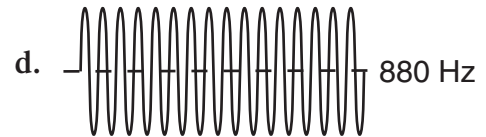
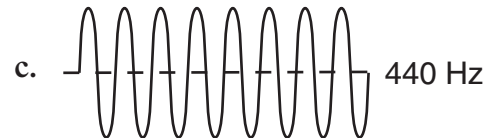
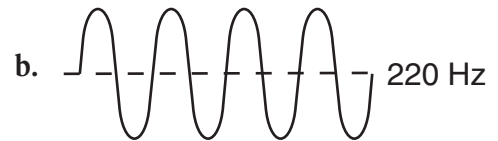
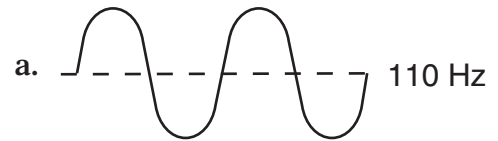

4. What is the frequency of the sound as shown on this meter?
- 4,300 Hertz
 - 5,300 Hertz
 - 6,400 Hertz
 - 6,700 Hertz

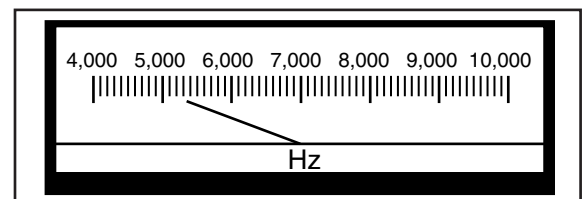

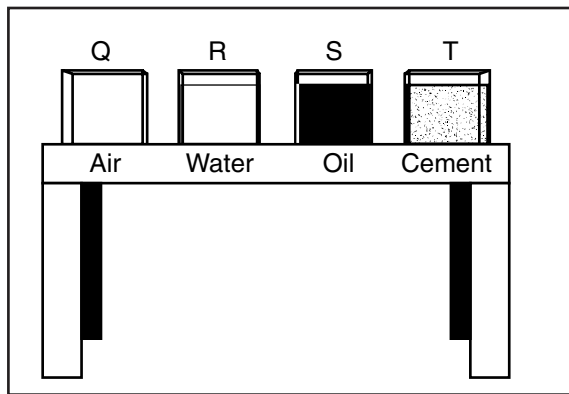

5. The picture shows four boxes filled with different materials. The same sound is going to be passed through each box. When the speed of the sound is measured, which box will the sound travel through the fastest?
- air
 - water
 - oil
 - cement

X-ray waves	Water waves
Radio waves	Sound waves
Light waves	Earthquake waves

Table A

Table B

6. The waves in Table A are different from the waves in Table B because only the waves in Table A transfer energy by _____.
- passing wavelengths
 - traveling through Earth's crust
 - vibrating electric charges
 - making particles of matter move

7. Electromagnetic waves have all of the following characteristics EXCEPT _____.
- wavelength
 - amplitude
 - frequency
 - compressional waves
8. In general, X rays benefit humans most by _____.
- cooking and heating food quickly
 - transmitting information over cellular and portable phones
 - damaging internal organs from prolonged exposure
 - helping doctors diagnose medical problems



DIRECTIONS

Read each question. Then, on your answer sheet, mark the answer choice that you think is best.

- 1** Which of the following is not a property of mechanical waves?

- A** moves around corners
- B** uses matter to transfer energy
- C** moves in the form of waves
- D** does not require matter to carry energy

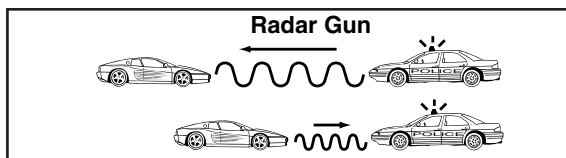

- 2** Police can detect speeding motorists with a radar gun. What property of waves enables them to do this?

- F** Waves bend when they strike an object.
- G** Waves bounce off when they strike an object.
- H** Waves bend around barriers.
- J** Two waves combine, travel together, and form a new wave.

- 3** When the wavelength of a sound is increased, its

- A** frequency will increase
- B** pitch will become higher
- C** frequency will decrease
- D** amplitude will increase

- 4** Which of the following is not a part of the ear?

- F** cochlea
- G** sinus cavity
- H** hammer
- J** eardrum

- 5** What is the main difference between mechanical waves and electromagnetic waves?

- A** Mechanical waves are produced by charged particles, and electromagnetic waves transfer energy through matter.
- B** Electromagnetic waves transfer energy, but mechanical waves do not.
- C** Mechanical waves transfer energy through matter, and electromagnetic waves are produced by vibrating charges.
- D** Mechanical waves transfer energy, but electromagnetic waves do not.

- 6** Infrared detectors can detect hidden things that give off heat. Which of the following would be a good use for an infrared detector?

- F** finding algae in a freshwater stream
- G** sending smoke signals to communicate with other people
- H** determining the temperature of a preheated oven
- J** finding people who are buried by an avalanche

Name: _____

Date: _____

Class: _____

Standardized Test Practice

Chapter 24 *Waves, Sound, and Light*

Directions: Read Numbers 7–8 below. Then, on the lines that follow, write your answers in complete sentences.

7 Transverse waves and compressional waves are both types of mechanical waves. Explain the similarities and differences between these two types of mechanical waves.

8 Describe an experiment that shows how the speed of sound is affected by temperature.

