



Standards and Procedures

Installation of Access Control Equipment
At
University of North Carolina at Wilmington

UNCW

REV 120617
Provided by UNCW Physical Security and Access

INDEX

OVERVIEW	3
OUTLINE	4
UNCW Door Hardware Standards.....	5
LENEL Network Communications.....	5
Door Control Cabling	6
Responsibilities	7
UNCW	7
Contractors.....	7
Standards for Termination of wires and cables in Lenel Panel, Lock Power Supplies, Readers, Hinges and Door Hardware	8
UNCW Wireless Access Control Standards.....	9
Example Photos of Installed Panels and Power Supplies	10
Panel with Power Supply	10
Inside Lenel Panel.....	11
Inside Power Supply Panel	12
Typical Installation for a Single Door	13
Typical Installation for a Double Door.....	14
Typical Installation for a Single Door with Handicap Opener	15
Typical Installation for a Double Door with Handicap Opener.....	16
UNCW Card Access Door Wiring.....	17
UNCW Lock Power Supply Wiring	18
UNCW Panel Wiring Standards	19
UNCW Lenel REX and Monitor Wiring for Double Doors.....	20
LNL-500 Wiring.....	21
LNL-1320 Wiring.....	22
LNL-2210 as an ISC Wiring.....	23
LNL-2210 as a Door Controller Wiring.....	24
LNL-2220 Wiring.....	25
LNL-3300 Wiring.....	26
Handicap Door Integration with PS 873 Power Supply	20
Handicap Door Integration with PS 914 Power Supply	28
UNCW Approved Parts List	29
Revision Notes	30
Physical Security and Access Contact Information	31

OVERVIEW

The purpose of this document is to define the standards and procedures for the installation of access control equipment, electronic locks, cables, wire and all ancillary equipment on the campus of the University of North Carolina at Wilmington (UNCW) and all properties owned or leased by the university.

The integrity of all equipment, cabling and proper installation is essential to the University's commitment to providing a safe and secure environment for students, faculty, staff and visitors of UNCW. These standards and procedures shall be reviewed and updated regularly to ensure they are up-to-date and accurate.

All standards and procedures in this document shall be compliant with all relevant laws or directives set forth by the Federal Government, the State of North Carolina, The University of North Carolina System and the University of North Carolina at Wilmington.

UNCW Physical Security and Access reserves the right to hire an outside contractor to perform electronic control equipment installation upon the review of the scope of the job and the timeframe necessary to complete the project. In addition, the overall costs associated with the equipment installation (i.e. labor) shall bear weight into the final decision of using contracted services versus UNCW Physical Security and Access.

OUTLINE

1. All Access Control Installations shall conform to the Americans with Disabilities Act and any other applicable local, state or federal regulations and must adhere to state and local fire code for life safety.
2. Cables and wiring shall conform to the standards set by UNCW ITS-NetCom and the particular solution installed in the building.
3. All Access Control door hardware shall be approved for use at UNCW. Any necessary changes will require approval from UNCW Physical Security and Access.
4. All equipment must be compatible with the Lenel OnGuard Access Control system.
5. All new and retro construction requiring Access Control shall use wired control devices. No wireless devices shall be installed on any door without prior authorization from UNCW Physical Security and Access
6. All Access Control equipment must come to the UNCW Physical Security and Access office prior to installation.

UNCW Door Hardware Standards

1. Door locksets shall be either Best electric mortise lock with request to exit and internal deadbolt switch with indicator (Included in the approved parts list of this document) or Von Duprin panic device with low current request to exit switch and approved by a UNCW Locksmith and UNCW Physical Security and Access.
2. Interior doors shall conform to a mortise lockset. Exterior doors shall conform to a panic device lockset. Electric strikes and Magnetic locks are NOT acceptable. All other configurations require approval from UNCW Locksmith and UNCW Physical Security and Access.
3. For proposed wireless solutions, please see page 9.
4. Card access equipment **MUST** be provided by an approved UNCW Certified Lenel VAR and the VAR must be approved by UNCW Physical Security and Access. Installation and wiring of all access control equipment **MUST** be performed by Lenel Certified technicians. Physical Security and Access **MUST** approve any equipment changes.
5. Power supplies for all electric locksets shall be Von Duprin model PS914-4RL. Power Supplies must be mounted in a secure space and shall NOT be installed above doors or ceilings. One PS914-4RL can control two (2) RIM devices. One PS 914-4RL can control up to four (4) electronic mortise locks or four (4) QEL devices.
6. Hinges for all card system doors shall be Hager hinge model BB1199 or BB1191 ETW-8 US 32D or Select continuous hinges with service panel and eight (8) through wires. Prep work of doorframe will be the responsibility of General Contractor. At grout filled frames, a mortar box (Example: Hager #430), shall be furnished for each electrified hinge and shall be furnished to the Hollow Metal Frame supplier for installation on the frame prior to the frame being shipped to the project site.
7. The preferred first choice of door monitoring shall be a magnetic ¾-inch diameter door position switch, such as a GE Security 1078C series or equivalent. If there is no provision for installing a magnetic door position switch, a plunger style, such as WINN Security BR-1032 or equivalent shall be allowed. On double doors where each leaf has a DPS, the devices shall be wired in series. Both sensors shall report alarms to the system as a single alarm point.
8. Doors with a 3-hinge configuration shall have the middle hinge being the electrified hinge. Doors with a 4-hinge configuration shall have the lower middle hinge being the electrified hinge. Hinge height should be 39" to 40" to top of hinge. Panic device electrified hinges shall be as close to even with the panic device as allowable for proper wire length from electrified hinge.
9. Interior doors specified with card access, and furnished with an electrified mortise lock shall contain a temperature control module built into the lockset, or shall have a temperature control module provided with the lockset.
10. Doors requiring a panic device shall include QEL electric latch retraction and low current request to exit switch.
11. ADA openers require a control cable, as specified in the door control section of this document, run from ADA opener to lock power supply, to be installed by the Contractor.
12. All Access Control Doors **MUST** include a door closer that conforms to all UNCW door hardware standards.

LENEL Network Communications

A network data drop is required at the main Lenel communications panel (UNCW will designate a network port). Additional Lenel door access panels in other areas of the building require a 2 pair 22 gauge stranded cable to the main Lenel Communications panel.

Door Control Cabling

From Telecom Closet to Junction box: A (1) inch conduit is required from the control board out to a junction box in the ceiling above the door to encase all the following wires:

- **Lock Power:** Refer to Chart

Lock	AWG	Max Distance	Example
EL98/99NL	12	180 Feet	Belden 8477
QEL98/99NL	12	300 Feet	Belden 8477
Mortise/Strike	16	300 Feet	Belden 8471

- **Door Position and Request to Exit Cables:**

In single door application: A (1) pair 22-gauge stranded cable is used for RX connections. This cable shall be run to the center door hinge area of the door using ¾-inch flex conduit from the junction box and shall be terminated with an electric pass through hinge. A (1) pair 22-gauge stranded cable for the DPS shall be run in ¾ inch flex conduit from the junction box to top of door frame, no farther than one foot from latch side of door.

In double door application: The right hand door from the outside or reader side shall require all specifications of single door wiring. The additional door shall require (1) pair 22-gauge stranded cable for the DPS and shall be run in ¾ inch flex conduit from the junction box to top of door frame, no farther than one foot from latch side of door, and a second (1) pair 22-gauge stranded cable will be required for RX connections in a ¾ inch flex conduit from the junction box to the center hinge of the door.

- **Card Reader Wire:**

Pulled to single gang box at the card reader location: A (3) pair 22-gauge shielded stranded gauge wire shall be used for the door reader and pulled through a ¾ inch flex conduit from the junction box to a single gang junction box in the area designated for mounting of the card reader.

- **Handicap Door Controller Cable:**

Pulled to Handicap Door Controller: If a handicap door opener is required, a Cat 6 cable or 22/6 stranded shielded wire shall be pulled from the access control board to the control board of the handicap opener. This shall pass through the junction box and be in a ¾ inch flex conduit to the handicap door opener control board. All terminations of this wire shall be performed by the installation contractor. Termination and installation of opener and paddles is the responsibility of the GC.

Responsibilities

UNCW

1. UNCW Physical Security and Access department shall oversee installation and maintain all Lenel and access control equipment as well as provide the department requesting Access Control with an estimate for the necessary Lenel and ancillary equipment.
2. UNCW shall provide all network equipment to include network switches. The UNCW Network Data Analyst shall assign any necessary switches, ports and IP addresses.
3. UNCW Physical Security and Access shall be responsible for setting up Status Levels, Door Schedules and assigning Access as appropriate.
4. The UNCW Network Infrastructure Analyst shall monitor the installation of wires and cables to ensure that all UNCW ITS-NetCom Department standards are satisfied.
5. The UNCW Project Manager shall provide “As Built” drawings to the UNCW Physical Security and Access department where applicable.

Contractors

1. The contractor shall ensure that they are operating in compliance with any North Carolina General Statutes that may be applicable to performing any part of their duties.
2. The contractor shall provide and pull all required low voltage power and data cabling as well as ground wire as required.
3. The contractor shall provide power supplies; install all conduits and any other necessary door hardware or other materials to complete the installation. All equipment shall be in accordance with UNCW Physical Security and Access Standards and UNCW standards for door hardware. Any substitutions must be submitted to the UNCW Physical Security and Access manager for approval or the Physical Plant as appropriate.
4. The contractor shall provide materials and electricians if additional 120 VAC services are required.
5. The contractor shall label all cables and wires to allow for UNCW Physical Security and Access personnel to identify the location and purpose of each cable or wire.
6. The contractor shall install all panels, power supplies and other electronic equipment associated with the Access Control System. The termination of all wires and cables shall be in accordance with the guidelines set forth in this document.

Standards for Termination of wires and cables in Lenel Panel, Lock Power Supplies, Readers, Hinges and Door Hardware

1. Splicing of wires and conductors shall **NOT** be permitted.
2. All lock power connections shall be made using solder and heat shrink tubing. Wire nuts and other such connectors shall not be permitted.
3. Connections at transfer hinges, readers, and other equipment other than lock power shall be made using 3M Scotchlok UY2 connectors or similar connectors in lieu of solder and heat shrink tubing, Wire nuts are not permitted.
4. Spare conductors in cables shall not be eliminated. Cut the spare conductors to the same length as the conductors in use and wrap them around the cable jacket for future use.
5. Cable, wires and conductors shall be cut so that a reasonable length is left for future service.
6. There shall be proper cable management of all wires, cables and cords in the Security room, in Lenel panels and lock power supplies. Cable grommets shall be used to route wires and cables into panels, cabinets and junction boxes.
7. The wiring color codes provided in this document shall be used when possible. UNCW Physical Security and Access must approve changes.
8. All Power Cords in the Security Room shall be plugged into a surge protector power strip.
9. All panels and power supplies shall be labeled so that service technicians can easily identify the location of readers, lock power, inputs and outputs.
10. Power tools shall **NOT** be used when installing soft, metal screws in door hardware.

UNCW Wireless Access Control Standards

Introduction

Wired readers and locks are the standard for Access Control on the campus of UNCW. The use of wireless equipment **MUST** be approved by UNCW Physical Security and Access. Wireless equipment shall not be used for external doors. Installation of wireless equipment **MUST** conform to the standards set forth in this document.

Standards

1. All access control equipment installed on the campus of UNCW **MUST** be compatible with Lenel OnGuard software and hardware. UNCW Physical Security and Access has approved the Allegion AD400 wireless electronic lock for limited use on campus. The AD400 lock shall conform to the following:
 - The appropriate lock type (mortise, cylindrical, RIM) shall meet all UNCW standards for door hardware.
 - The lock shall include a Schlage SIK2 reader designed for use with the HID iClass format and include a keypad.
 - The lock shall include the “Privacy” Function (40).
 - The lock trim color shall be grey with the 626 satin finish and Sparta lever.
 - The lever cylinder type shall conform to the UNCW standard. The appropriate Allegion part number code is “BD.”

2. PIM (Panel Interface Modules) **MUST** be purchased from an approved Lenel VAR and the firmware flashed for use with Lenel OnGuard software and hardware. The approved PIM types are as follows:
 - PIM400-485 – PIM is used for RS-485 communications and will only function with the LNL-3300 ISC when multiple PIMs are required or the LNL-2210 ISC when a single PIM is necessary. The PIM must be attached to a dedicated communication port on the ISC (Integrated System Controller) as they will not function properly in a circuit that includes wired Reader Interface Modules such as the LNL-1320.
 - PIM400-1501 – PIM includes an onboard LNL-2210 ISC and communicates directly with the network. This PIM will support a maximum of 16 AD400 wireless locks.
 - UNCW Physical Security and Access **MUST** be consulted as to which PIM solution shall be employed to ensure maximum functionality and expandability of the wireless system.

3. A wireless signal survey **MUST** be performed to accurately determine the location of all PIMs to ensure proper communication to all associated wireless locks. UNCW Physical Security **MUST** perform the survey. Contractors may schedule to be present if desired.

Example Photos of Installed Panels and Power Supplies

Panel with Power Supply



Inside Lenel Panel

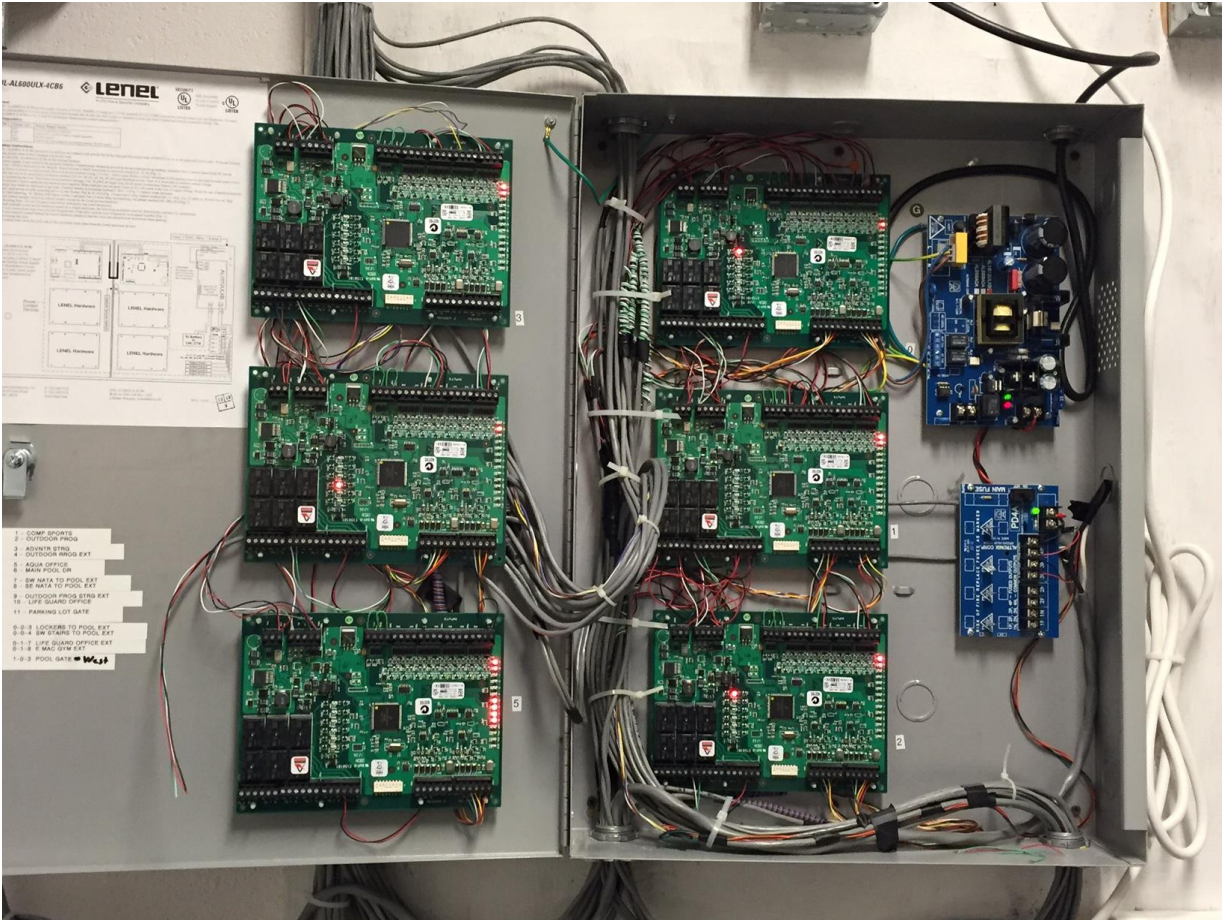

Inside Power Supply Panel

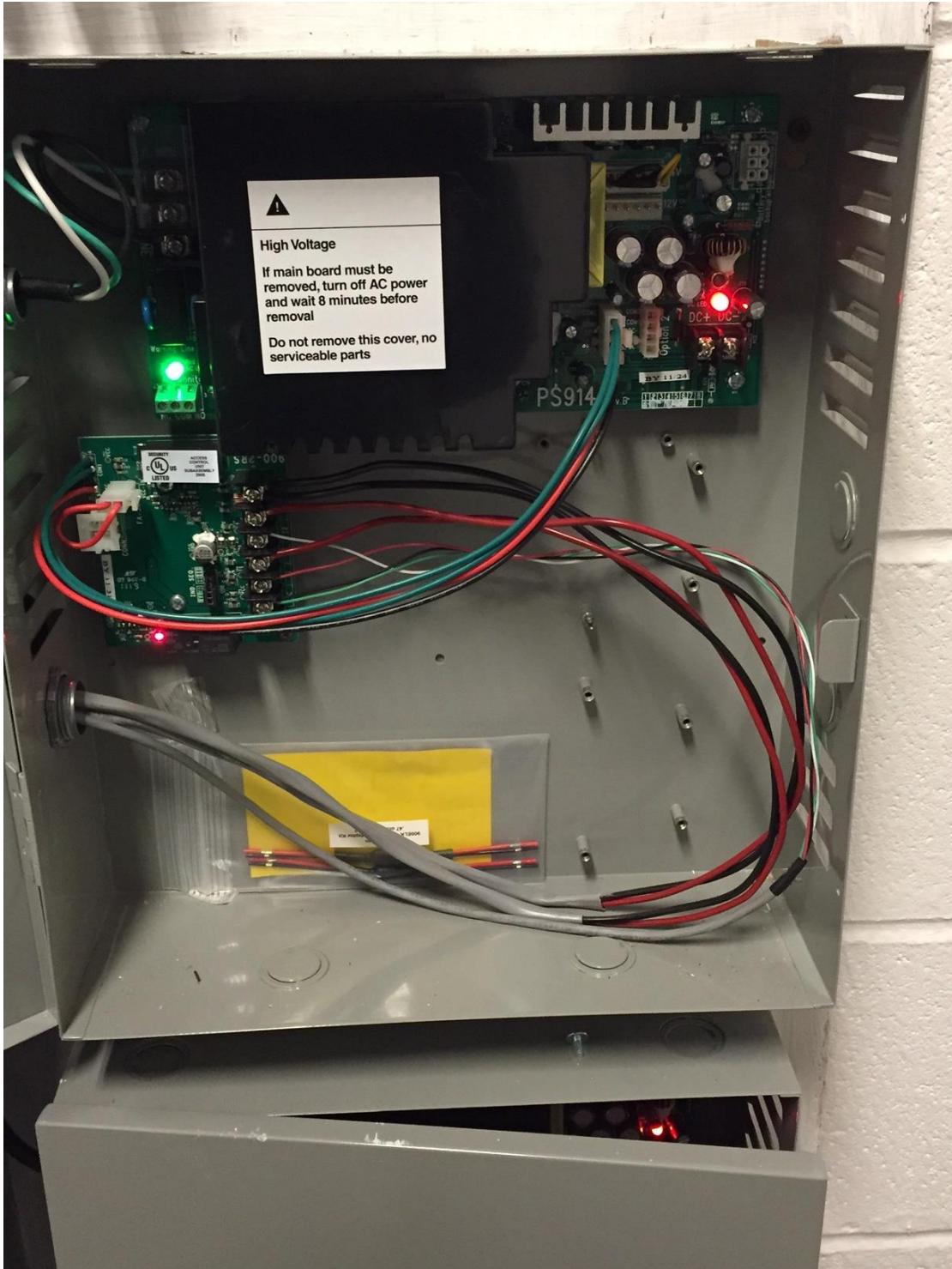

Typical Installation for a Single Door with a Magnet DPS

Typical Access Control Installation for a Single Door with Magnet DPS

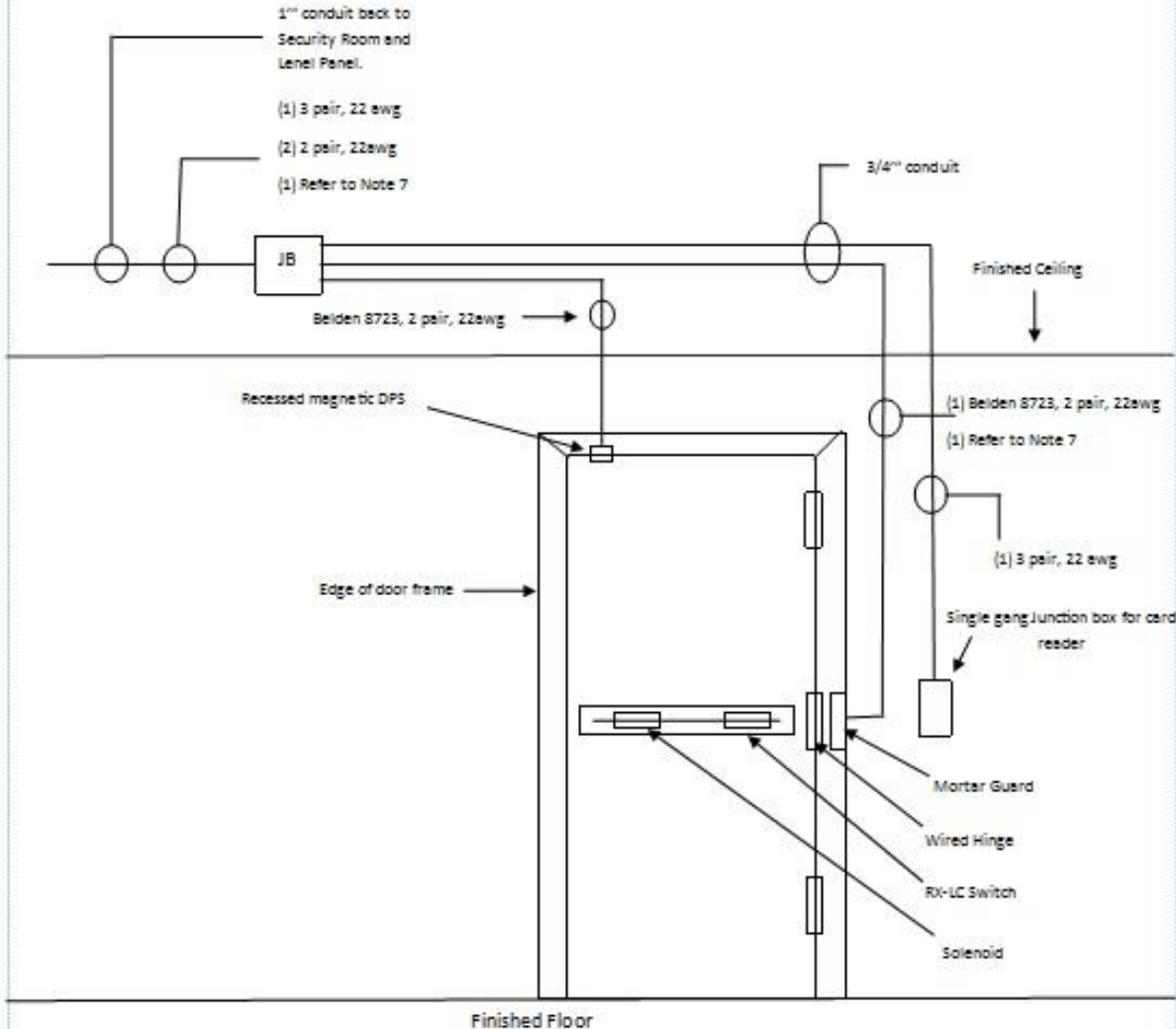

NOTES

1. Door orientation, outside looking in.
2. (JB) Cabling Junction Box
3. All hardware shall coordinate with hardware schedule.
4. All cable, conduit and hardware shall be installed by contractor.
5. Power Supply and Access Controller must be located in Security Room.
6. Contractor shall make all wire terminations in accordance with UNCW Access Control Standards. Wire splices are NOT permitted.

7. Lock Power Wire Gauge and Distance Chart

Lock	AWG	Max Distance	Example
EL98/99NL	12	180 Feet	Belden 8477
QEL98/99NL	12	300 Feet	Belden 8477
Mortise/Strike	16	300 Feet	Belden 8471

Typical Installation for a Double Door with a Magnet DPS

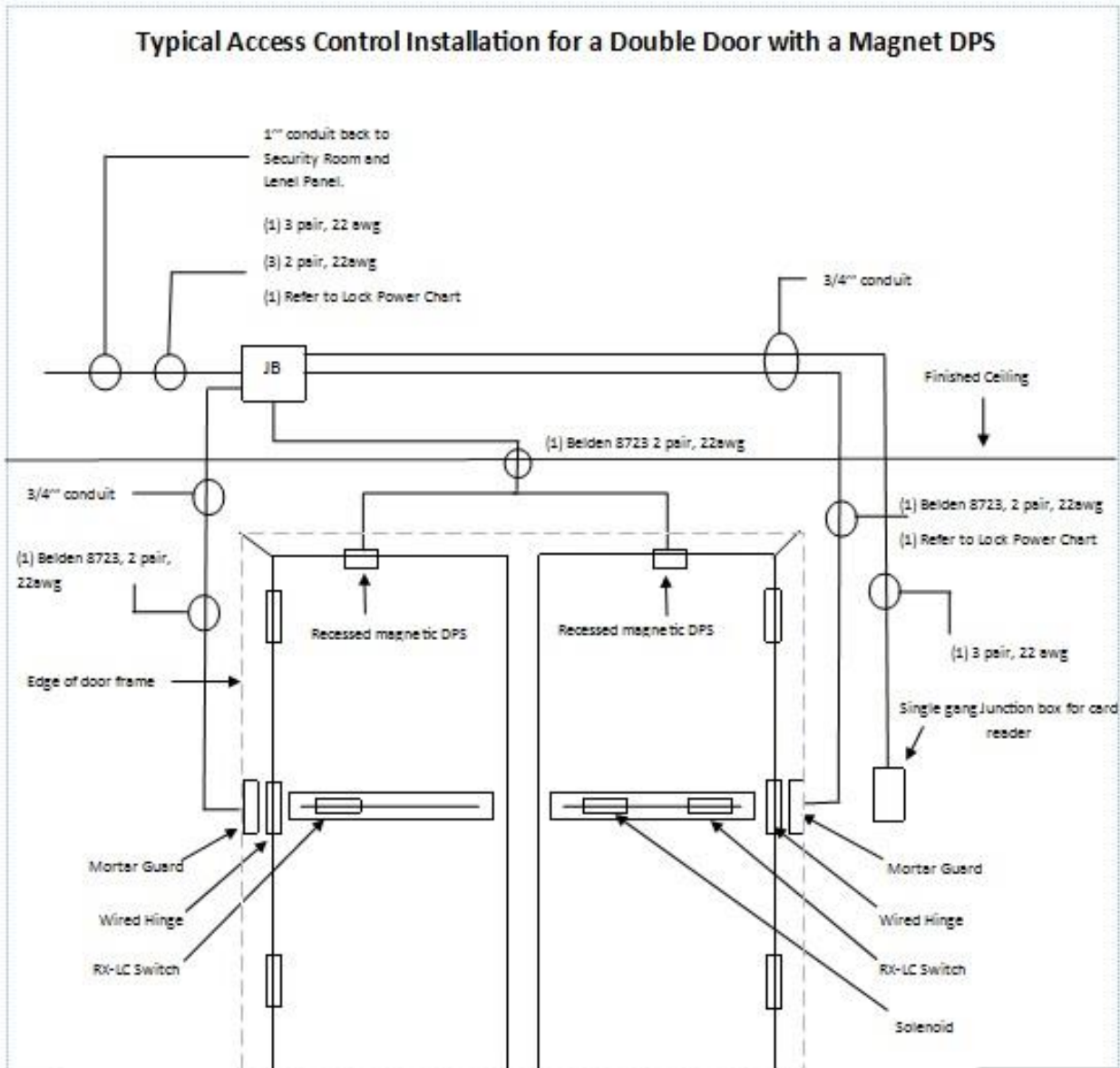

NOTES

1. Door orientation, outside looking in.
2. All hardware shall coordinate with hardware schedule.
3. All cable, conduit and hardware shall be installed by contractor.
4. Power Supply and Access Controller must be located in Security Room.
5. Contractor shall make all wire terminations in accordance with UNCW Access Control Standards. Wire splices are NOT permitted.

Lock Power Wire Gauge and Distance Chart

Lock	AWG	Max Distance	Example
ELSB/99NL	12	180 Feet	Belden 8477
QELSB/99NL	12	300 Feet	Belden 8477
Mortise/Strike	16	300 Feet	Belden 8471

Typical Installation for a Single Door with Handicap Opener w/ Magnet DPS

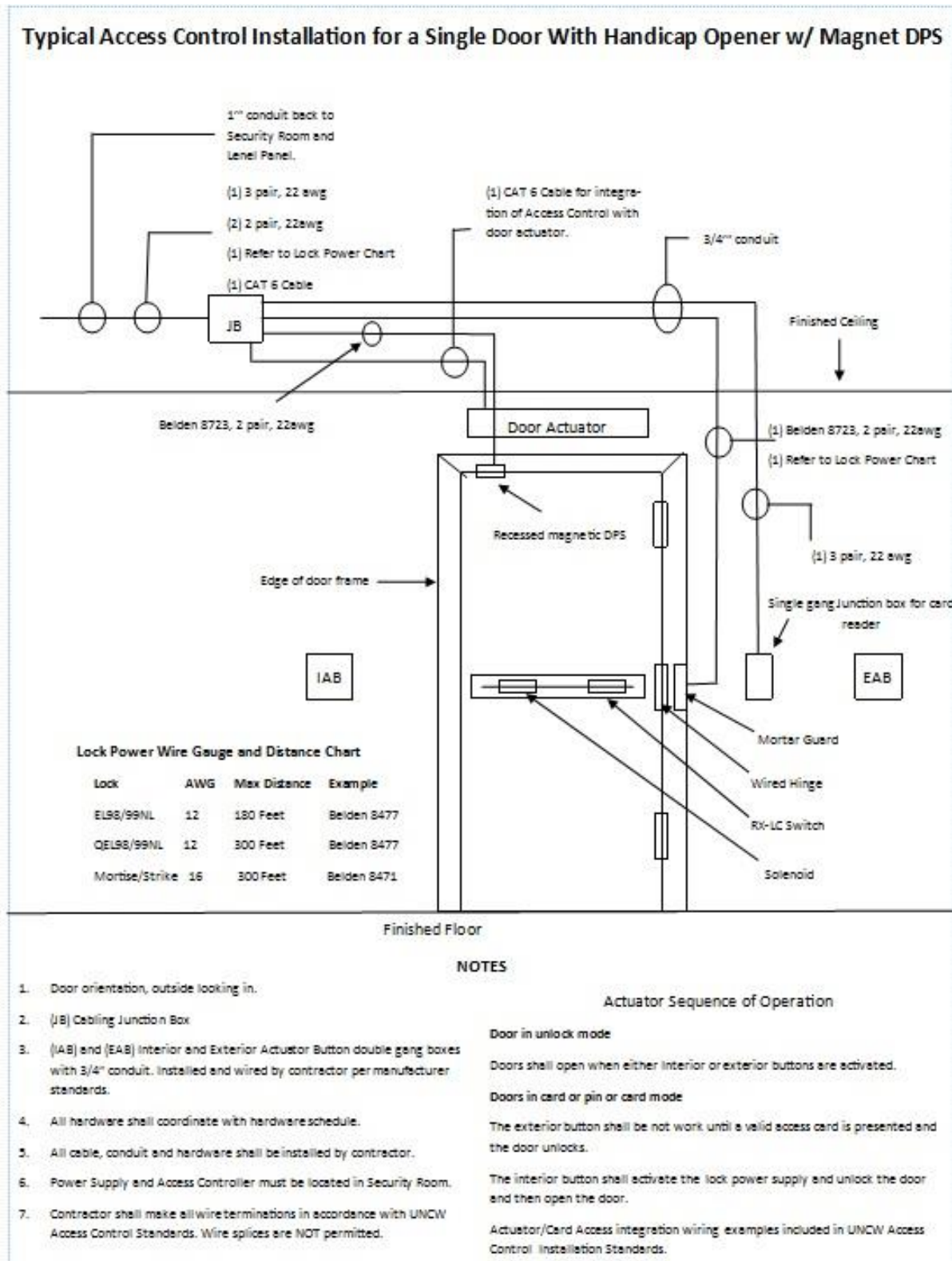

Typical Installation for a Double Door with Handicap Opener w/ Magnet DPS

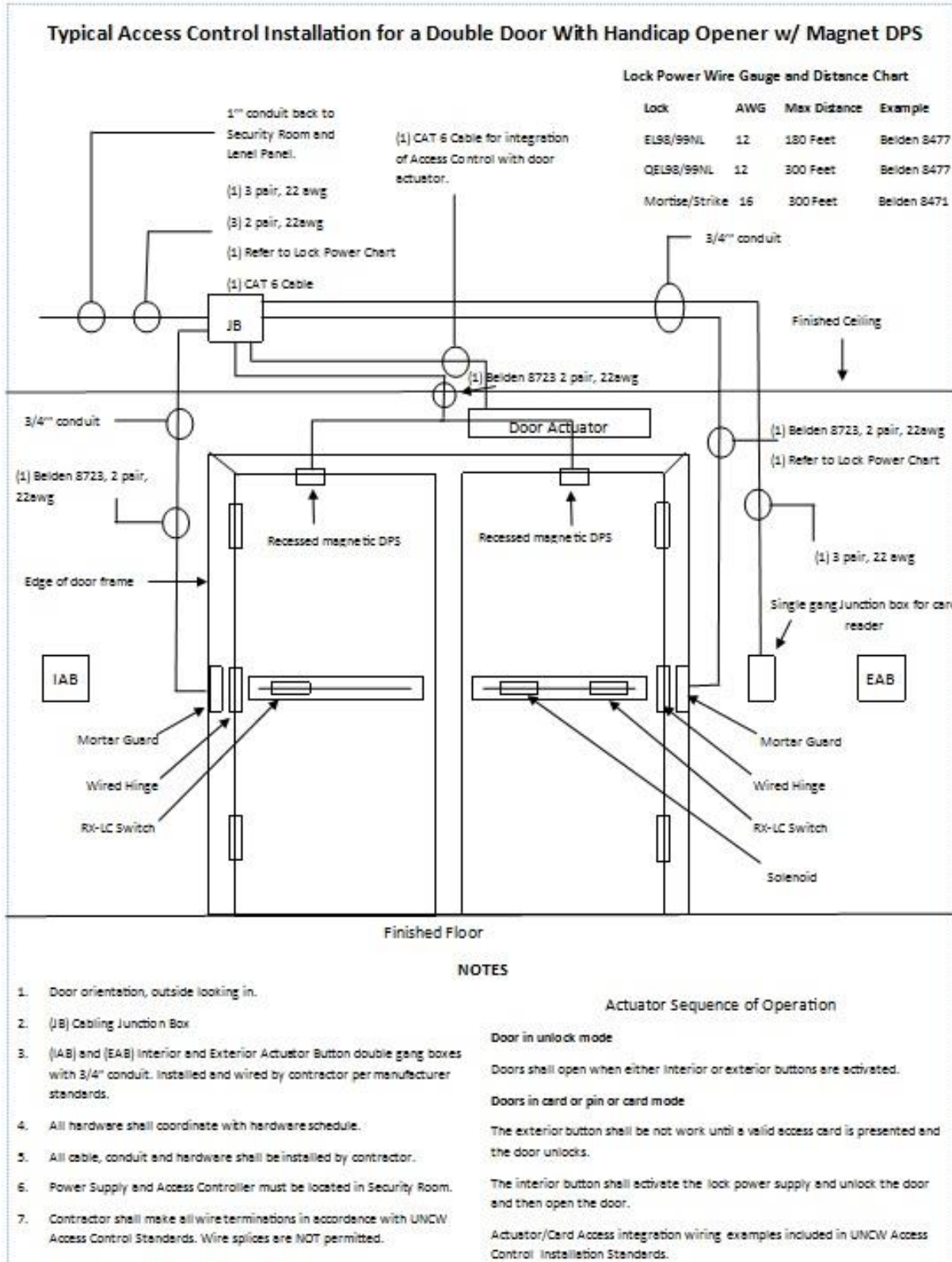

UNCW Card Access Door Wiring

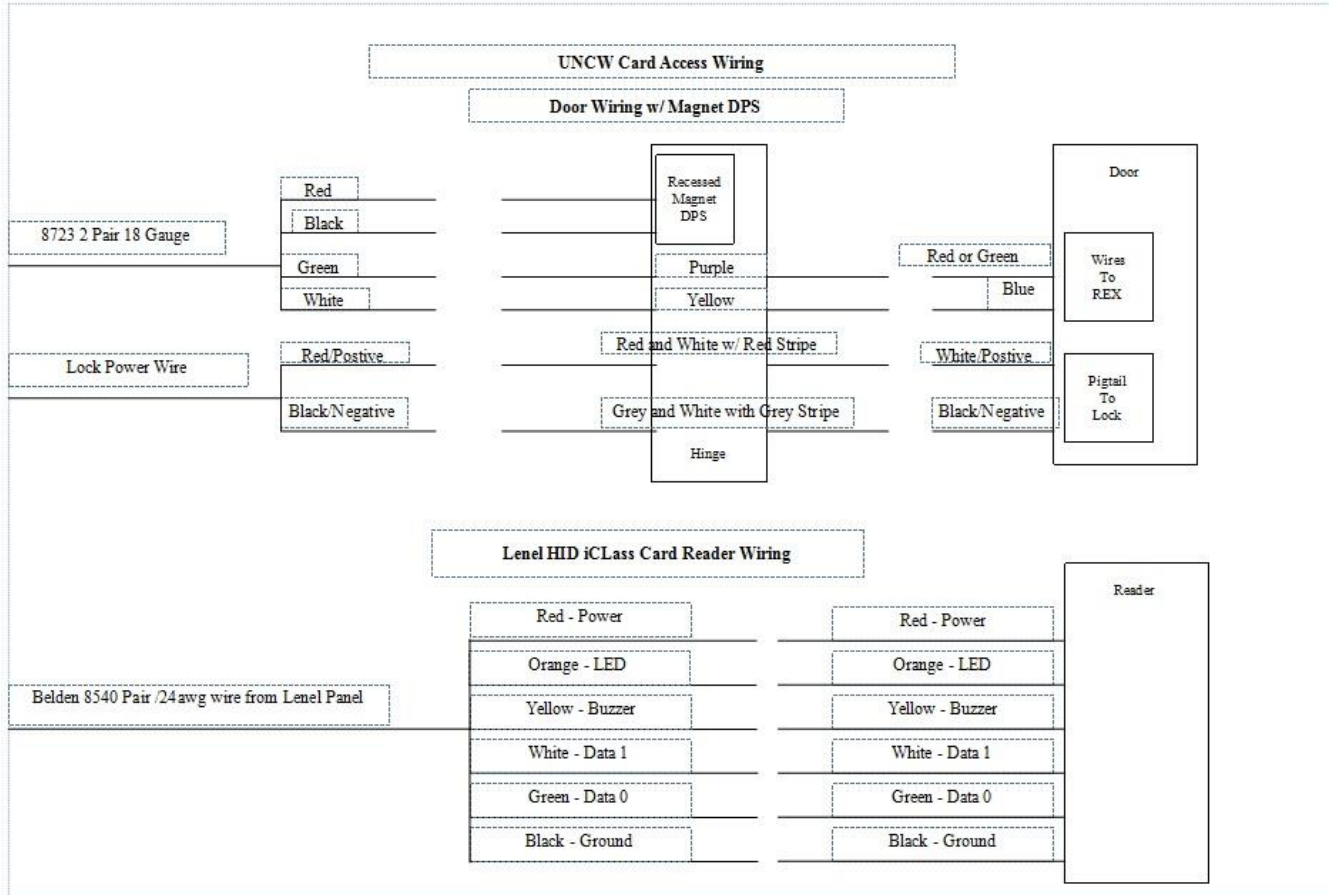

UNCW Lock Power Supply Wiring

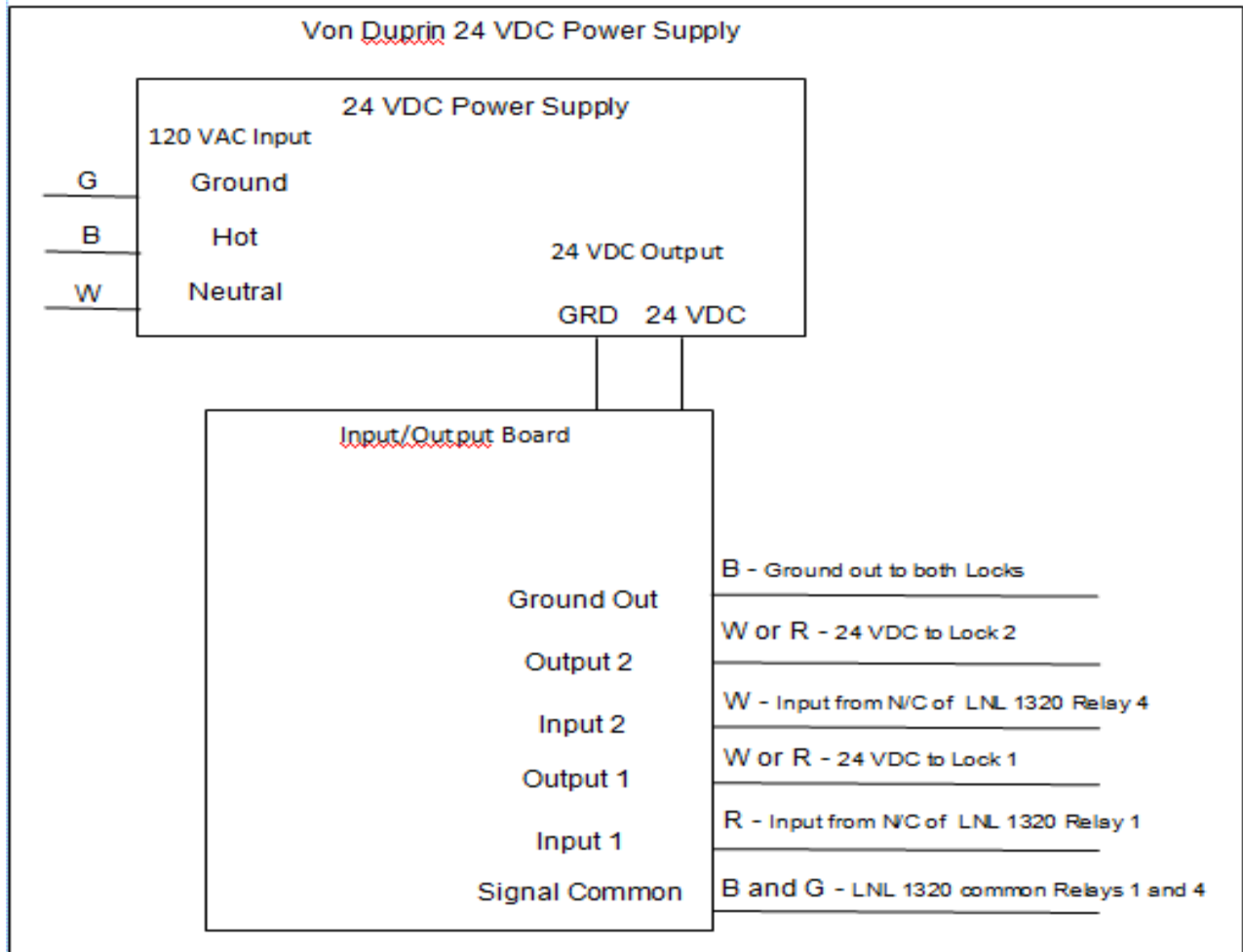

Index

G - Green
 B - Black
 R - Red
 W - White

UNCW Level Panel Wiring Standards

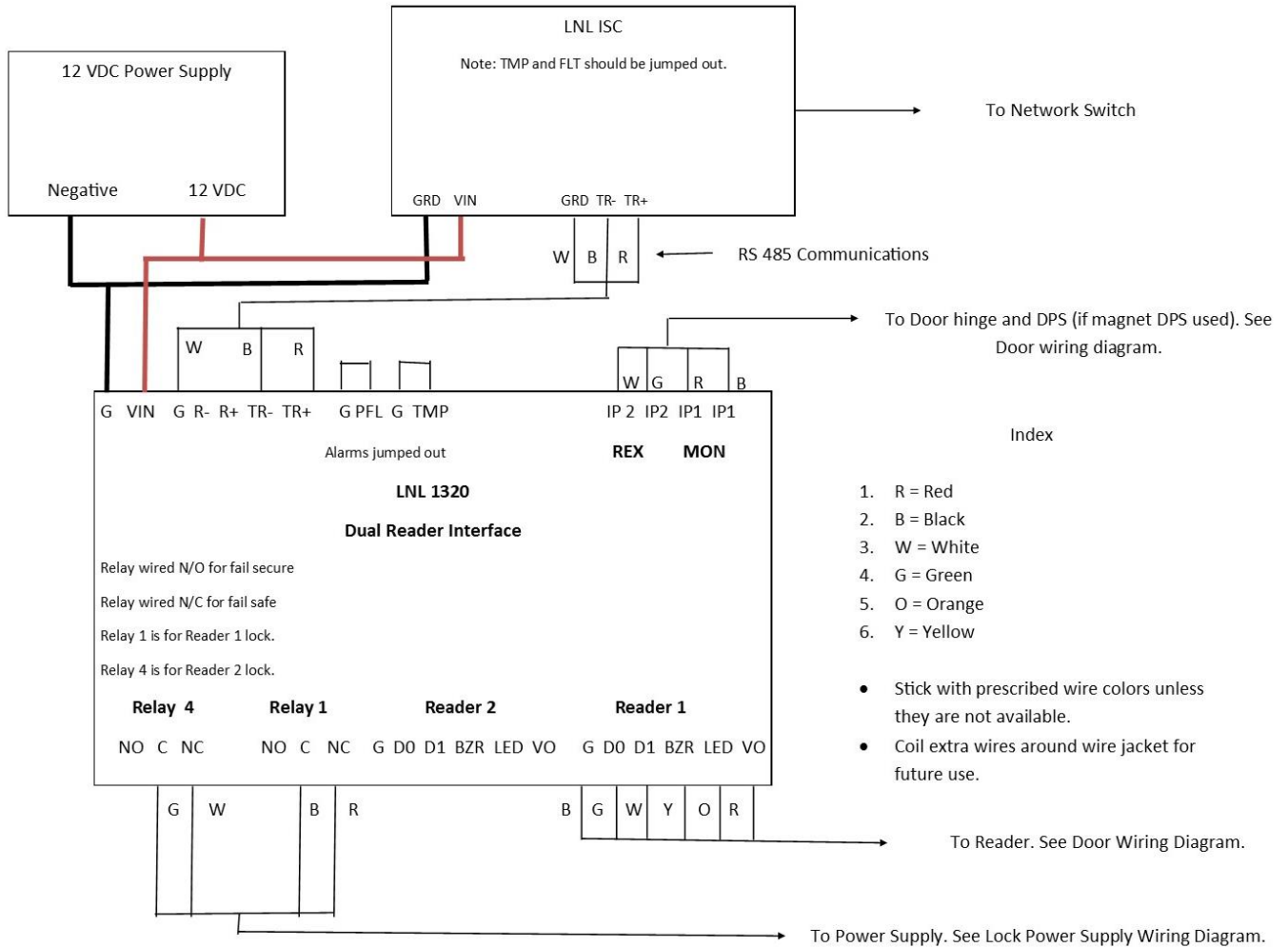

UNCW Level REX and Monitor Wiring for Double Doors

Request to Exit Switch (REX) - Normally Open Contact (N.O) - Wired in parallel at input 2 for Reader 1 and input 6 for reader 2 on LNL 1320. Wiring done at the panel **NOT** the door.

Door Monitors—Normally Closed Contacts (N.C.) - Wired in series at input 1 for reader 1 and 5 for reader 2. Wiring done at the panel **NOT** the door.

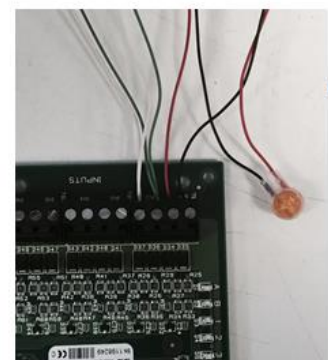
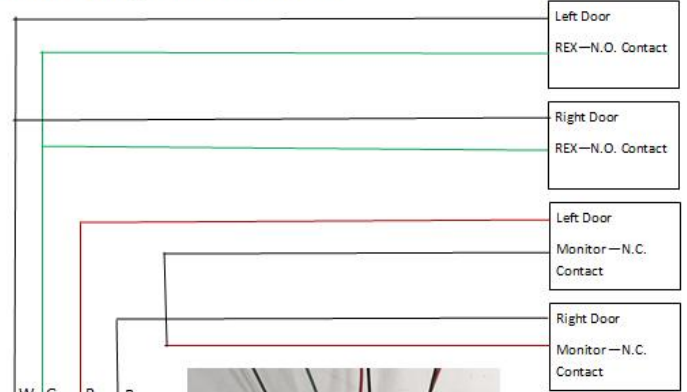
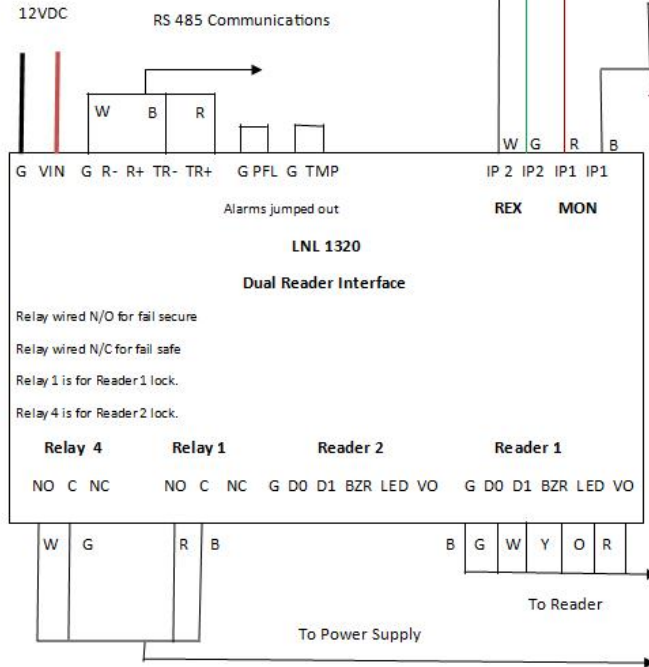

Example Pic

Index

1. R = Red
2. B = Black
3. W = White
4. G = Green
5. O = Orange
6. Y = Yellow

LNL-500 Wiring



LNL-1320 Wiring

LNL-1320 Duel Reader Interface Module

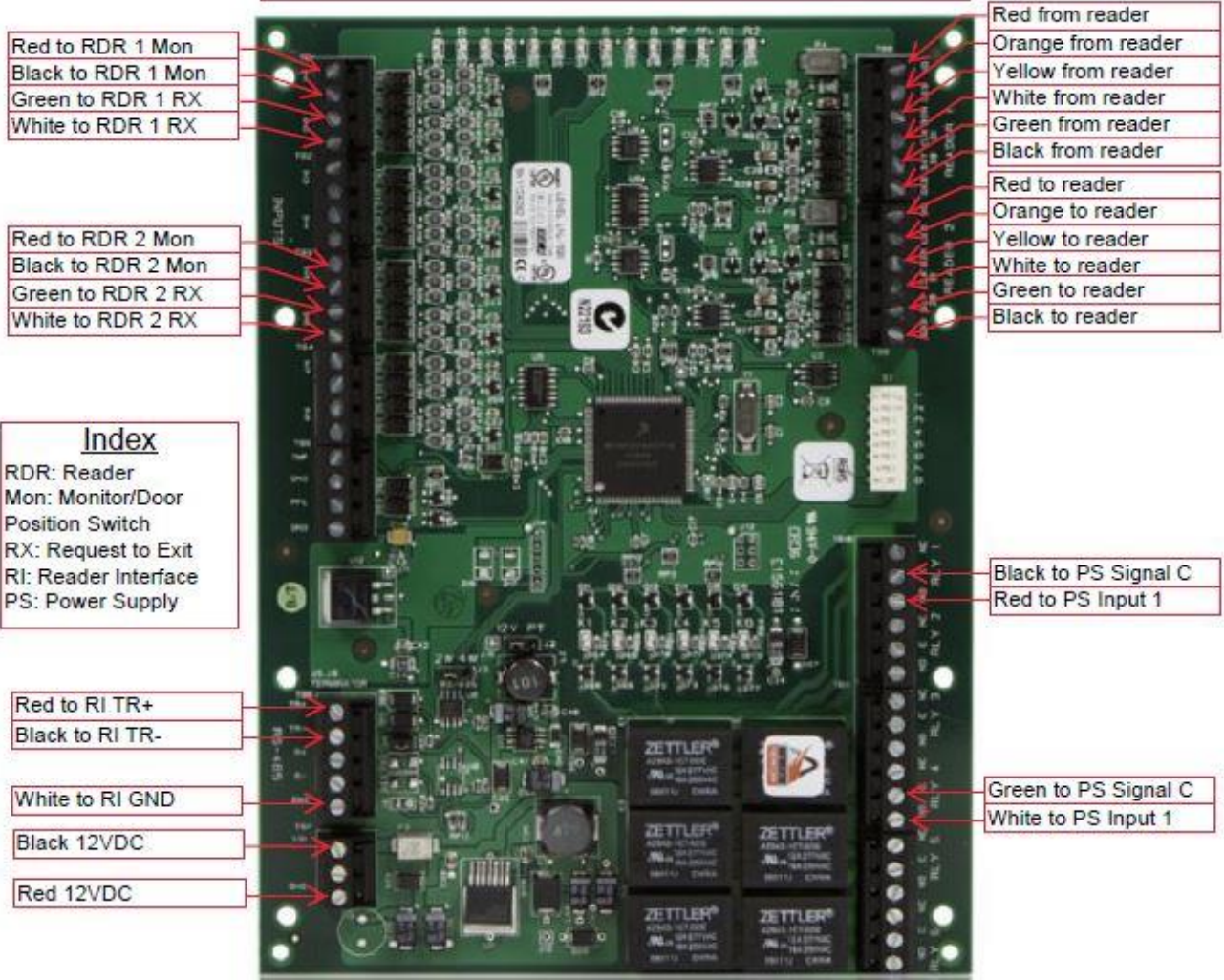

LNL-2210
(Wired as ISC)

**LNL-2210 Intelligent Single Door Controller
Functioning as Intelligent System Controller**

Index
RI: Reader Interface

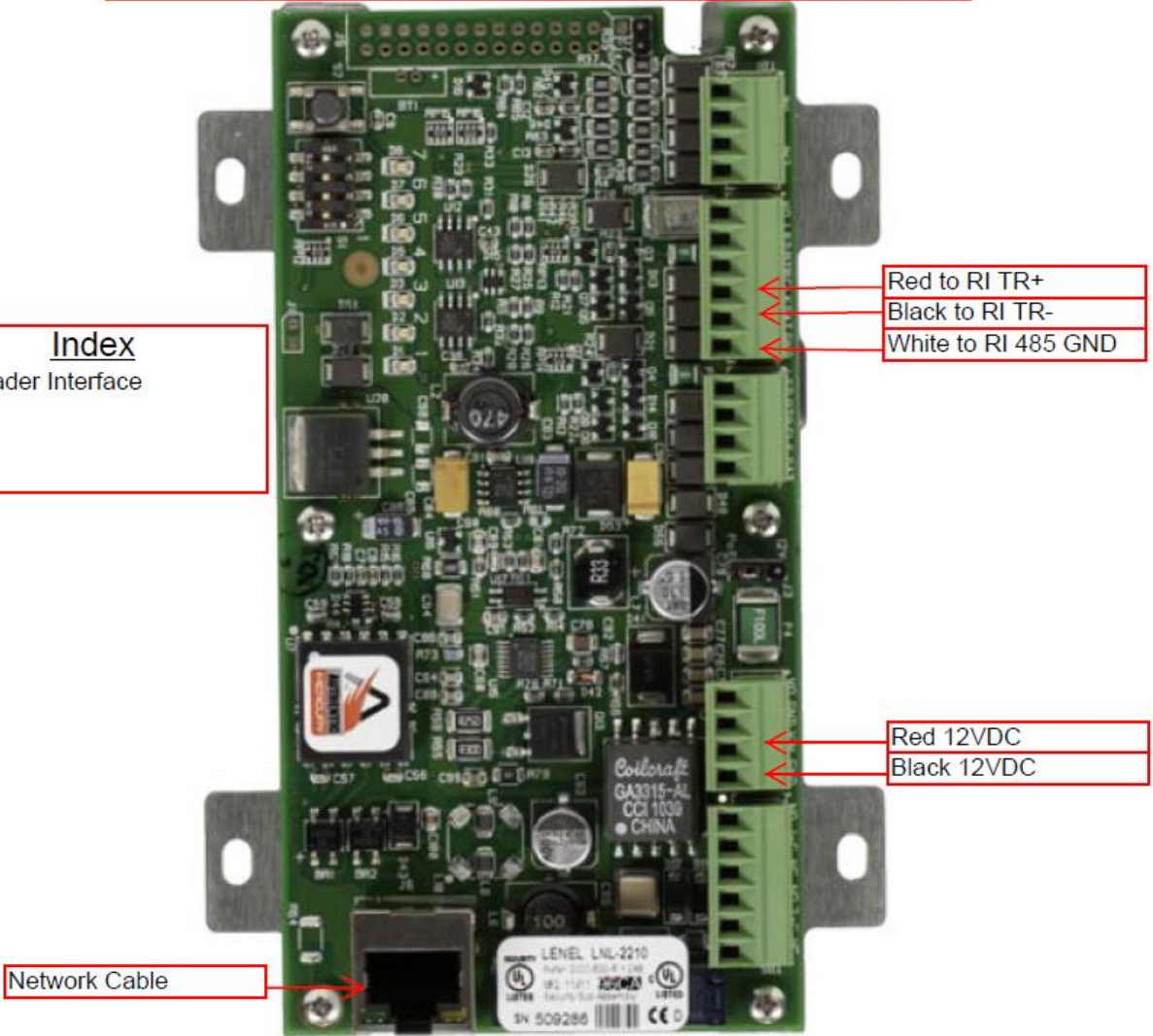

LNL-2210

(Wired as a Single Door Controller)

LNL-2210 Single Door Controller

Index

Mon: Monitor/ Door position switch
 RX: Request to Exit

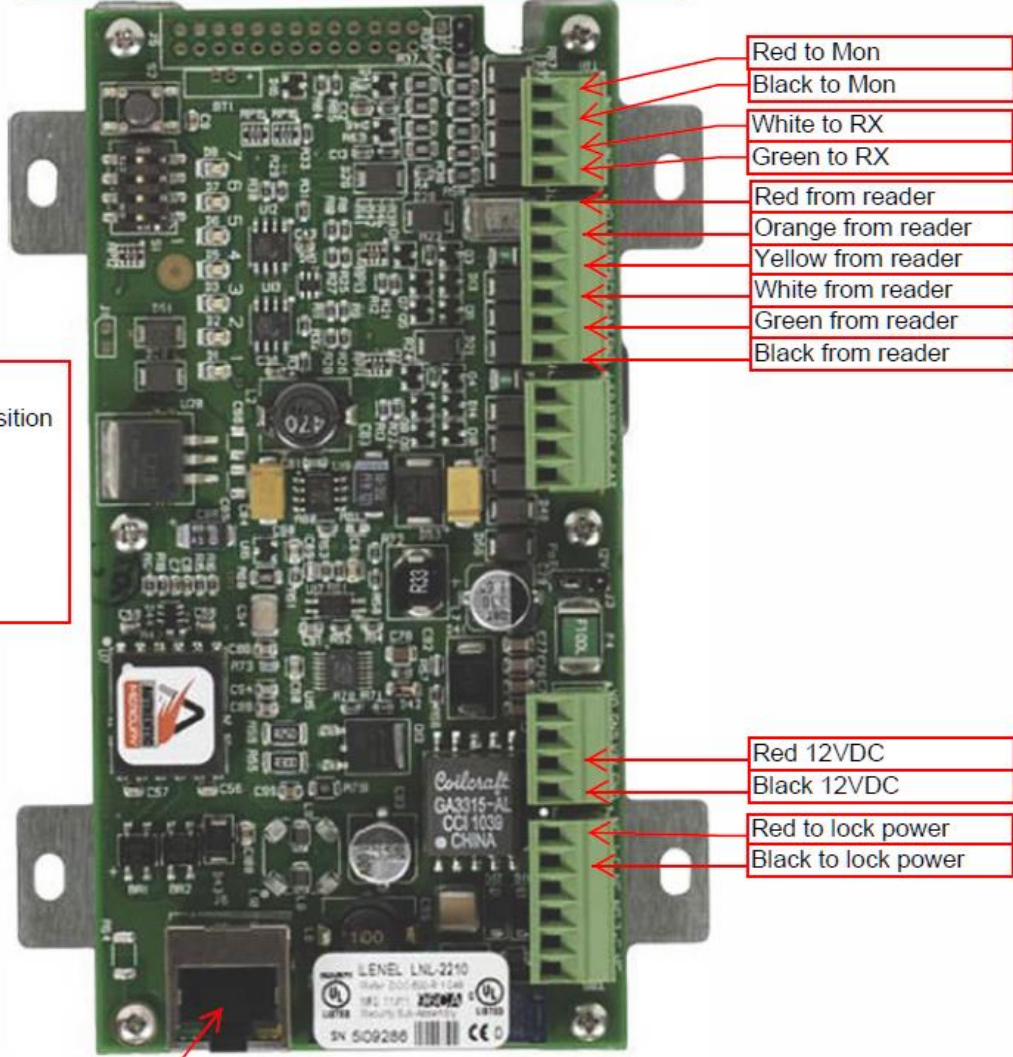

- Red to Mon
- Black to Mon
- White to RX
- Green to RX
- Red from reader
- Orange from reader
- Yellow from reader
- White from reader
- Green from reader
- Black from reader

- Red 12VDC
- Black 12VDC
- Red to lock power
- Black to lock power

Network Cable

LNL-2220

LNL-2220 Intelligent Dual Reader Controller

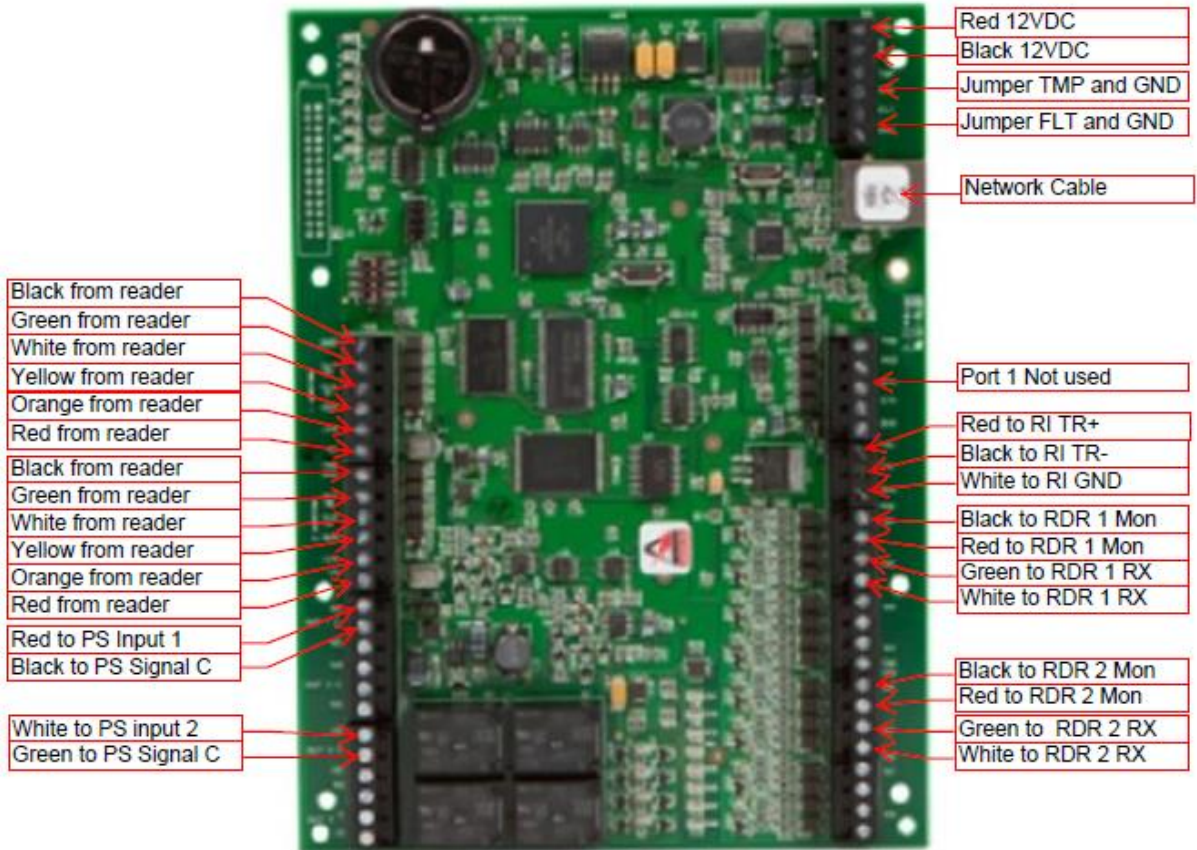

Index

RDR: Reader
Mon: Monitor/ Door position switch
RX: Request to Exit
RI: Reader Interface
PS: Power Supply

LNL-3300



Handicap Door Integration with PS 873 Power Supply

UNCW Access Management

Wiring Diagram for the integration of Card Access with Automatic Door Openers (Old Von Duprin 873 Power Supplies)

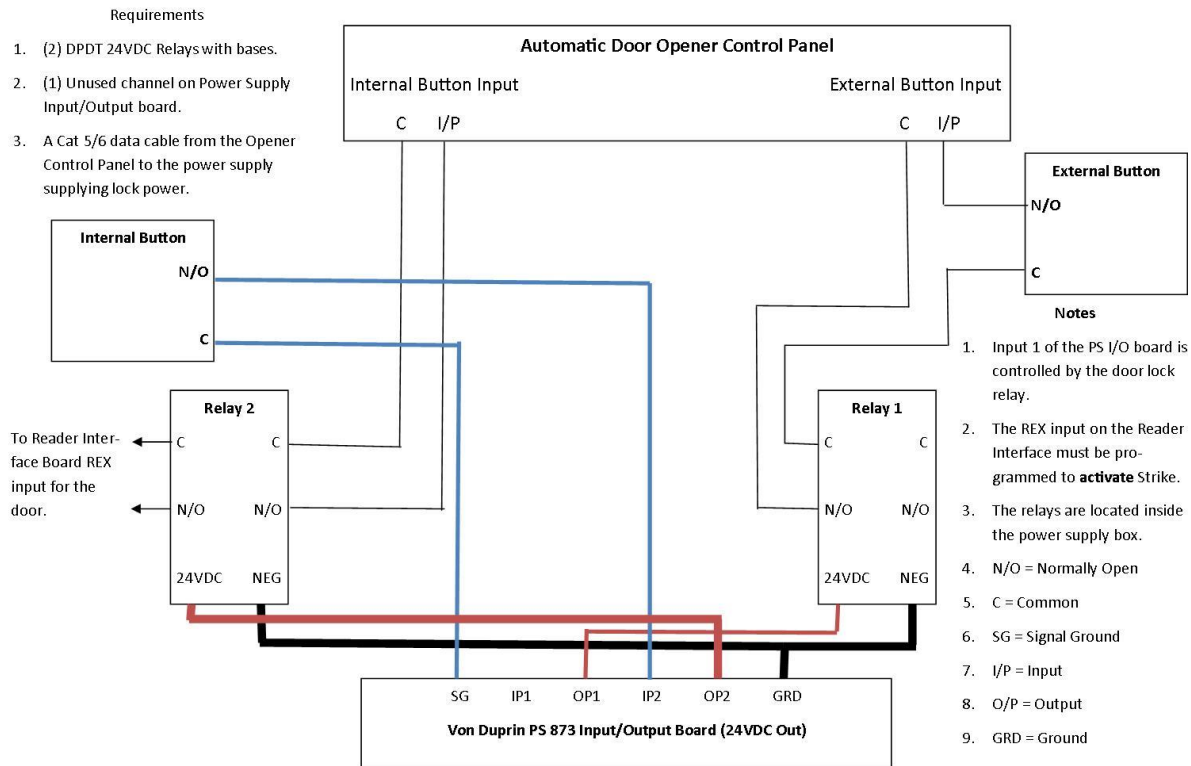

Handicap Door Integration with PS 914 Power Supply

UNCW Access Management

Wiring Diagram for the integration of Card Access with Automatic Door Openers (New Von Duprin 914 Power Supplies)

Requirements

1. (2) DPDT 24VDC Relays with bases.
2. (1) Unused channel on Power Supply Input/Output board.
3. A Cat 5/6 data cable from the Opener Control Panel to the power supply supplying lock power.
4. Von Duprin 900-4RL 4 Relay Output w/Logic Board.

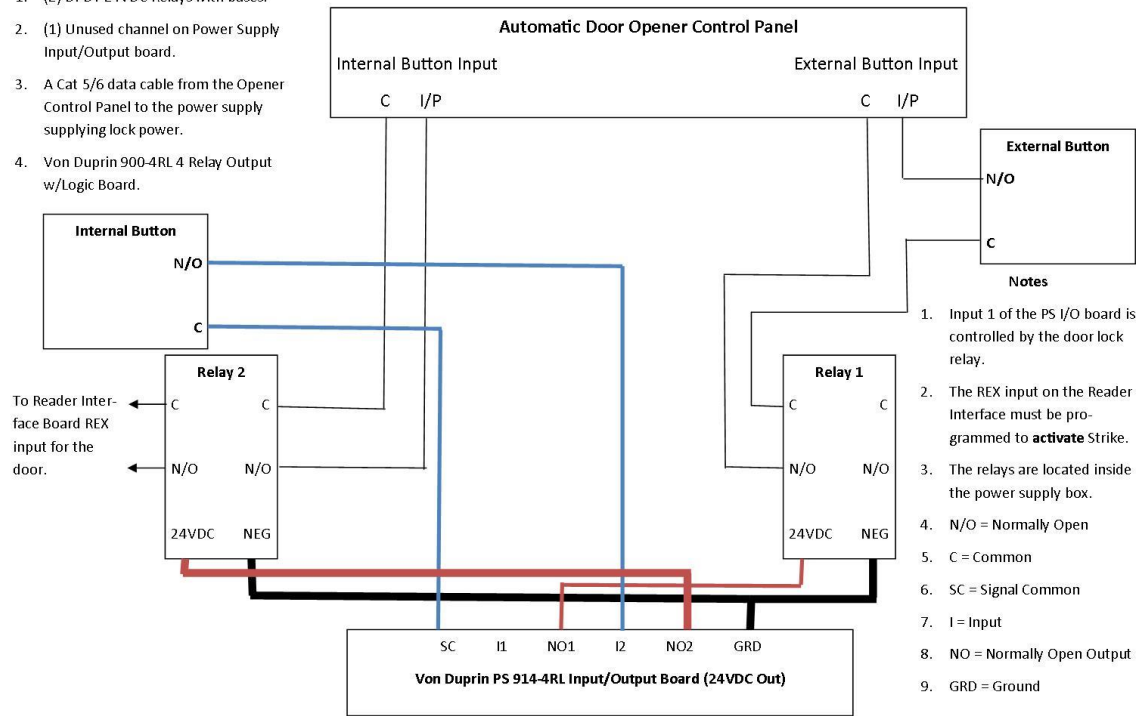

UNCW Approved Parts List

Description	Part Number
Door Hardware and Power Supplies	
Electrified Von Duprin Crash Bars w/ Request to Exit Switch	RXLC EL(QEL) 99/98NL
Best Electric Mortise Lock w/ Request to Exit Switch and Internal Dead Bolt Thumb Switch with Indicator (Both parts required for complete unit)	45HW7TDEU14H626IDH24VPR 40HVITH626
Von Duprin Power Supply with I/O Card	PS914-4RL
Hager Electric Hinges	BB1199/1191 ETW-8-US32D
Von Duprin Electrical Power Transfer	EPT-10
Select Electric Continuous Hinge w/ Removable Panel (NOTE: Part # will vary according to the handing of the door and position of the removable panel)	SL11-HD-EMS/CTW-8-RP-Clear
Von Duprin Chexit Device	CX98/99 NL x 0 second Delay
Von Duprin Crash Bars w/ Request to Exit Switch (no EL Kit)	RXLC 99/98NL
Relay for Handicap Door Integration Relay, 8Pin, DPDT, 10A, 120VAC	Omron LY2-AC110/120 or equal
Relay Base for Handicap Door Integration Relay	Dayton 10E075 or equal
Allegion AD400 Wireless Lock	AD400 (lockset) 40-SIK-SPA-626-BD
Allegion PIM (RS-485)	LNL-PIM400-485
Allegion PIM (Network)	LNL-PIM400-1501

Revision Notes

- Rev. 082011 – Added new model of Von Duprin Power supply
Added LC (low current) RX switch to standards
Removed pneumatic handicap door opener
- Rev. 022014 – Allow contractors to install complete card access systems.
Standard lock power supply was changed to a Von Duprin PS914-4RL.
Diagrams detailing lock power, door, and panel wiring were added.
- Rev. 012715 – Includes diagrams of Access Management expectations when installing Lenel panels and power supplies in security rooms/closets by contractors. Updated wiring and door installation diagrams.
- Rev. 082715 – Added new drawing for wiring REX and monitor for double doors in parallel.
- Rev. 091115 – Updated model of hinge used to no longer include monitor. Declared first choice for door monitoring preference as magnet door position switch and second choice as plunger style, including drawings to showing wire installation.
- Rev. 030716 – Updated drawings for wiring requirements and removing any name reference to Business Applications.
- Rev. 102116 – Updated drawings to remove references to monitored hinges.
Updated department name from Access Management to Physical Security and access.
Added Lenel parts verification to standards.
- Rev. 012417- Added wireless device policy
Added statement regarding pre-installation of equipment to PS&A office
- Rev. 020817 – Updated policies & part numbers.
- Rev. 061917 – Added Wireless device standards. Amended lock power wire gauge and maximum distance standards. Added requirement for installation technicians to be Lenel certified. Added documentation and drawings for wiring of Lenel ISC boards. Added wireless parts and part numbers to Approved Parts List.
- Rev. 110817 – Added Best Electric Mortise Lock for use at internal doors and removed the Schlage Electric Mortise Lock. The verbiage in various places has been edited to reflect slight changes in standards or improve legibility.
- Rev. 120617 – Change to correct Best Mortise Lock part numbers.

UNCW Physical Security and Access

Contact Information:
Accessmgmt@uncw.edu
(910)962-3564

Please contact the Physical Security and Access Manager with any questions or concerns pertaining to this document.