

STANLEY[®]

Security Solutions



SLIDING & FOLDING DOOR HARDWARE

COMMERCIAL HARDWARE

STANLEY[®]

TABLE OF CONTENTS

Company history2
 Nomenclature explained.....3

 BiFold hardware3-13
 BF204,5
 BF30.....6-9
 BF5010,11
 BF125N12,13

 ByPass hardware14-19
 BP60 & BPD60.....14-17
 BP150N & BPD250N18,19

 Pocket door hardware20-23
 PD7520
 PD150N21
 PDF150N & PDF250N22, 23

COMPANY HISTORY



**The Stanly Works
 New Britain, CT in 1843**

As a young man in 1843, Frederick T. Stanley founded The Stanley Works – a small company located in New Britain, Connecticut that manufactured hinges, bolts and other door hardware in a one-story wooden building.

Mr. Stanley’s vision was to create a hardware company with unsurpassed customer service, product innovation and integrity – and to offer products that would become the first choice among professionals around the world.

With the early success of this mission and an increasing demand for his high-quality goods, Mr. Stanley began exporting his products in the 1870s.

Today, Stanley is a global organization supplying hardware and tools for the architectural, consumer, industrial and residential markets worldwide. Utilizing state-of-the-art research, manufacturing and quality-control capabilities, Stanley continues to deliver the innovative, high quality products that have made the Stanley name synonymous with the highest craftsmanship and dependability for more than 160 years.

To our valued customers, we appreciate your loyalty over the years and proudly present our Architectural Hardware offering.

Commercial Customer Service: 1-800-337-4393
www.stanleyhardware.com

SLIDING AND FOLDING DOOR HARDWARE

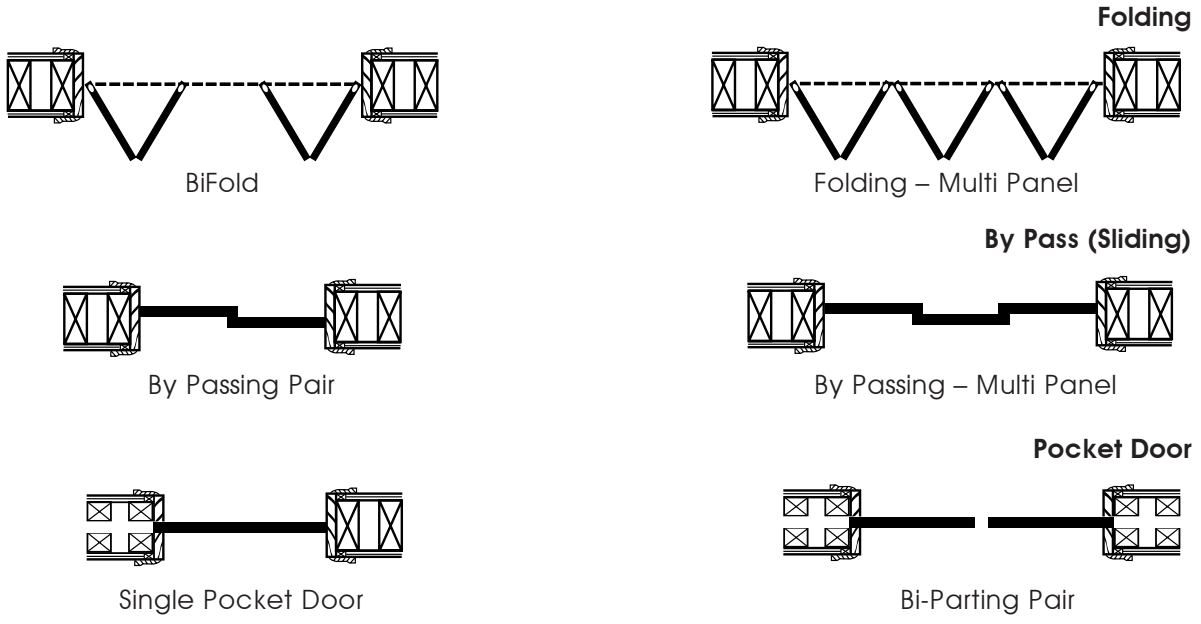

Nomenclature: Application + Weight + Component = Class Number

Application	Weights		Components	
BF = BiFold	20 lbs	9 Kg	Track = 01-09	
	30 lbs	14 Kg	Pivot Brackets = 10-19	
	50 lbs	23 Kg	Snuggers = 20-29	
	125 lbs	57 Kg	Pivots = 30-39	
BP = ByPass	60 lbs	27 Kg	Hangers = 40-49	
	150 lbs	68 Kg	Pulls = 60-69	
	250 lbs	113 Kg	Bottom Guides = 70-79	
PD = Pocket Door	75 lbs	34 Kg	Jamb Brackets = 80-89	
	150 lbs	68 Kg	Bottom Guide Track = 90-99	
PDF = Pocket Door Frame	150 lbs	68 Kg		
	250 lbs	113 Kg		

Example: BF (Bi-Fold) – 125 (125 lbs.) – 41 (Hanger)

Metric Conversions

1 in. = 25.4 mm 1 mm = .039 in.

Inches	Millimeters	Inches	Millimeters
1/16.....	2	1-3/4.....	44
1/8.....	3	2.....	51
3/16.....	5	2-3/4.....	70
1/4.....	6	3-1/2.....	89
5/16.....	8	12.....	305
3/8.....	10	18.....	457
7/16.....	11	24.....	610
1/2.....	13	30.....	762
9/16.....	15	36.....	914
5/8.....	16	48.....	1219
11/16.....	18	60.....	1524
3/4.....	19	72.....	1829
13/16.....	21	84.....	2134
7/8.....	22	96.....	2438
15/16.....	24	120.....	3048
1.....	25	144.....	3658
1-3/8.....	35	192.....	4877

Average Door Weight Chart

Door Thickness	Inches		mm		Inches		mm	
	13/8"	35	13/4"	44	2"	51		
	lbs/ft ²	kg/m ²	lbs/ft ²	kg/m ²	lbs/ft ²	kg/m ²		
Hollow Core	2	9.8	2 1/2	12.2	–	–		
Solid Core	3 1/2	17	4 1/2	22	5 1/4	25.6		
Pine (White)	3	14.6	3 1/2	17	4	19.5		
Oak	5	24.4	7	34.2	8	39		
Ash	4	19.5	5	24.4	6	29.3		
Fir	3	14.6	3 1/2	17	4	19.5		
Birch	4 1/4	20.8	5 1/2	26.9	6 1/4	30.5		
Mahogany	3 1/2	17	4 1/2	22	5 1/4	25.6		

BiFold Hardware



BF20

20 lb. Panel Bifold

For installation of 2 or 4, 7/8" to 1 3/8" thick panels weighing up to 20 lbs. each.

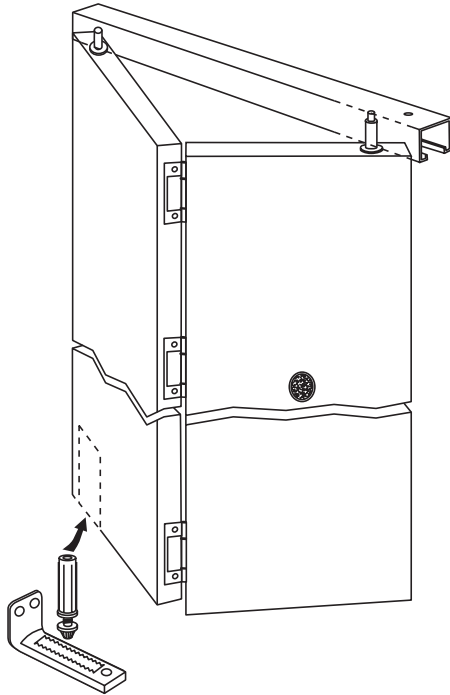

Features

- Snug-fit top pivot and roller guide for easy installation
- Durable pre-painted track
- All metal components galvanized against corrosion
- Easily adjustable after installation

ANSI Reference

- BF20 conforms to ANSI A156.14 type D8623

Cross Reference

- STANLEY 2800 series
- Crowder CF-100
- Sterling 1530/8000
- Lawrence C649S/L850S

Sizing Information

Finished Opening/Panel Dimensions

To determine panel width:

Panel width = known finished opening width divided by number of panels, less 1/4"

To determine opening width:

Opening width = known finished panel width plus 1/4", multiplied by number of panels

Door height = 1 1/2" to 2" less than finished opening height

Installation Detail

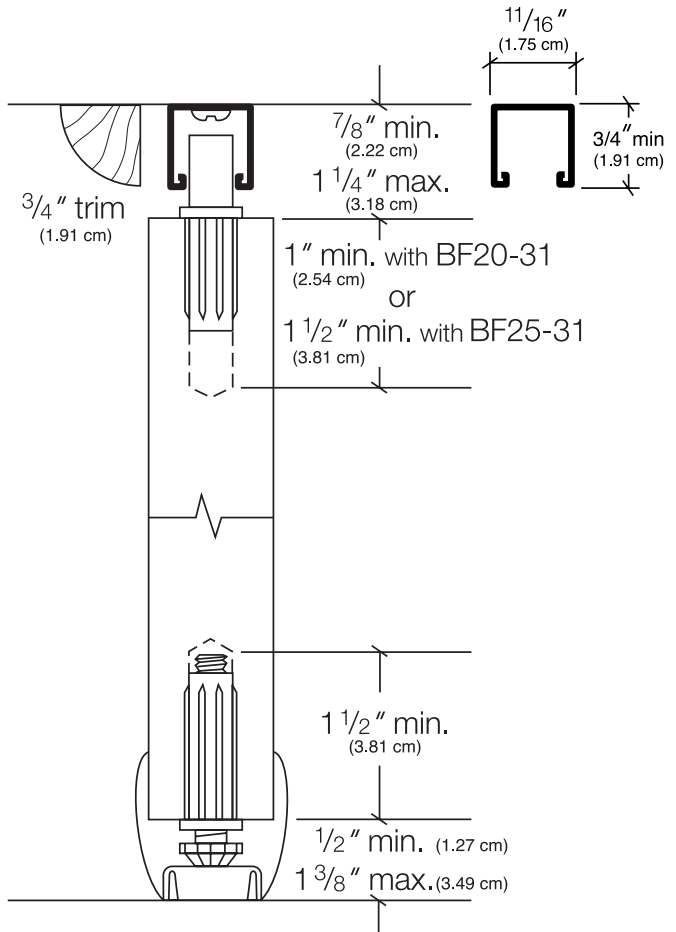





Track with Pivot Bracket

Track Number	Number of Panels	Length	Finish	Case Qty.	Case Weight	EDP Number
BF20-01-24	2	23 3/4"	WHITE	25 EA.	13 LBS	52 4252 001
BF20-01-30	2	29 3/4"	WHITE	25 EA.	16 LBS	52 4292 001
BF20-01-32	2	31 3/4"	WHITE	25 EA.	17 LBS	52 4316 001
BF20-01-36	2	35 3/4"	WHITE	25 EA.	18 LBS	52 4336 001
BF20-01-48	4	47 3/4"	WHITE	25 EA.	26 LBS	52 4344 001
BF20-01-60	4	59 3/4"	WHITE	25 EA.	31 LBS	52 4368 001
BF20-01-72	4	71 3/4"	WHITE	25 EA.	36 LBS	52 4400 001

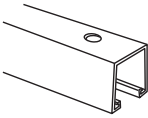
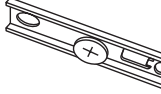
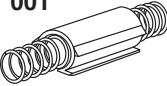
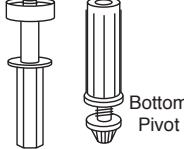
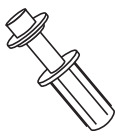
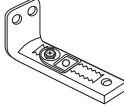
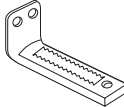
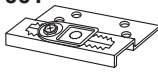
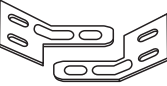
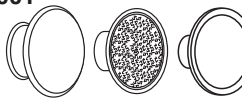
Hardware Components

BF20

Steel Track	EDP No.
BF20-01-XX - White	**
	
Pivot Bracket	Case Qty. EDP No.
BF20-10	200 ea. 52 4236 001
	
Snugger	Case Qty. EDP No.
BF20-23-4Door	200 ea. 52 4297 001
3/4"-7/8" edge to hole	
	
Pivots	Case Qty. EDP No.
BF20-31-Top Pivot Guide	400 ea. 52 4208 001
BF30-33-Bottom Pivot	200 ea. 52 4212 001
	
Top Pivot Bottom Pivot	
Top Guide Pivot	Case Qty. EDP No.
BF25-31	200 ea. 52 4452 001
For 25 lb. panels	
	
Jamb Bracket	Case Qty. EDP No.
BF30-81- 3/4" screws	200 ea. 52 4200 001
Easy horizontal adjustment	
	
BF50-81- 3/4" screws	200 ea. 52 2252 001
With pivot block for mounting above floor	
	
BF50-83	200 ea. 52 2264 001
Floor bracket for slab floor installations	
	
Aligners	Case Qty. EDP No.
BF50-72	100 pr. 52 2224 001
For use in four door installations	
	
Knobs	Case Qty. EDP No.
BF50-61- Plastic	100 pr. 52 1244 001
BF50-62- Wood	100 pr. 52 1280 001
BF50-65- Brass	400 pr. 52 1236 001
	
Wood Plastic Brass	

Hinges	Length	Case Qty.	EDP No.
220-3	3"	300 pr.	52 1012 001
Non-mortise, In-line holes, w/screws, brasstone			
220-3LS	3"	300 pr.	52 1016 001
Non-mortise, In-line holes, no screws			
221-3	3"	300 pr.	52 1032 001
Non-mortise, offset holes, no screws, brasstone			
224-Satin Brass Finish	300 pr.	52 1052 001	
Flatback Hinge, no screws 2 1/2"x 1 5/8"			
234-Bright Zinc Finish	300 pr.	52 1076 001	
Flatback Hinge, no screws 2 1/2"x 1 5/8"			
224RC-Satin Brass Finish	300 pr.	52 1053 001	
Flatback Hinge, no screws with raised countersinks for Medium Density Fiberboard (MDF) panels 2 1/2"x 1 5/8"			
Screws	Case Qty	EDP No.	
220-121SC	600 sets	52 1024	
Brass Tone Finish			
Drill Point Screws for 220 hinge			
#2 Phillips drive #6 x 7/8" flat head			
221-SC	600 sets	52 1040	
Brass Tone Finish			
Screws for 220-3/221-3 hinge			
#2 Phillips drive #6 x 7/8" flat head			
214-121SC	300 sets	52 1004	
Brass Tone Finish			
Self drilling screws for 224/234 hinge			
#2 Phillips drive #8 x 5/8" pan head			
214-SC	300 sets	52 1000	
Brass Tone Finish			
Screws for 224/234 hinge			
#2 Phillips drive #8 x 5/8" pan head			

BF20 Bagsets

CLASS NO.	PART DESCRIPTION	52 4492 001 2867-2
BF30-81	Bracket Jamb Blue Zinc	1
BF20-21	(2DR) Snugger	1
BF20-31	Top Guide/Pivot	2
BF30-33	Bottom Pivot	1
BF50-61	Plastic Knob	1
	#8 x 1 1/2" Flat Head Screw	5
	#8 x 1 3/4" Truss Head Knob Screw	1
	#8 x 3/4" Flat Head Screw	5

BiFold Hardware

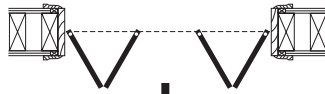

BF30

30 lb. Panel Bifold

For installation of 2 or 4, 7/8" to 1 3/8" thick panels weighing up to 30 lbs. each.

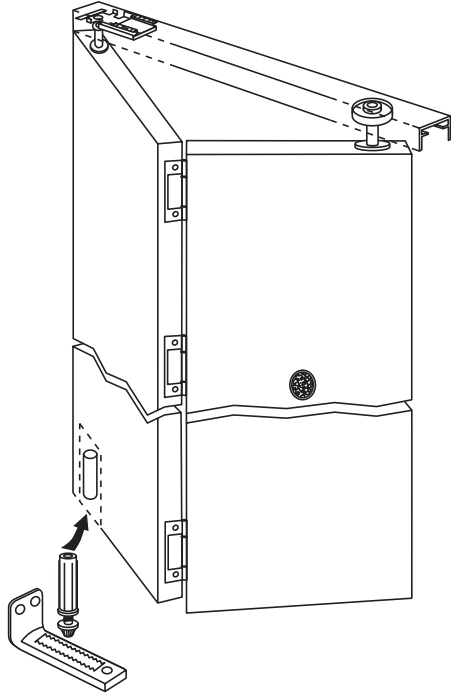

Features

- Spring loaded top pivot and roller guide for easy installation
- Permanently lubricated roller guide
- Durable pre-painted track
- All metal components galvanized against corrosion

ANSI Reference

- BF30 conforms to ANSI A156.14 type D8622, D8662

Cross Reference

- STANLEY 2400/2900 series • Cox 43/48
- Hager CD-2670 • Lawrence C 620/640
- Johnson 1838 • Sterling 1540/9000

Sizing Information

Finished Opening/Panel Dimensions

To determine panel width:

Panel width = known finished opening width divided by number of panels, less 1/4"

To determine opening width:

Opening width = known finished panel width plus 1/4", multiplied by number of panels

Door height = 1 5/8" less than finished opening height

Installation Detail

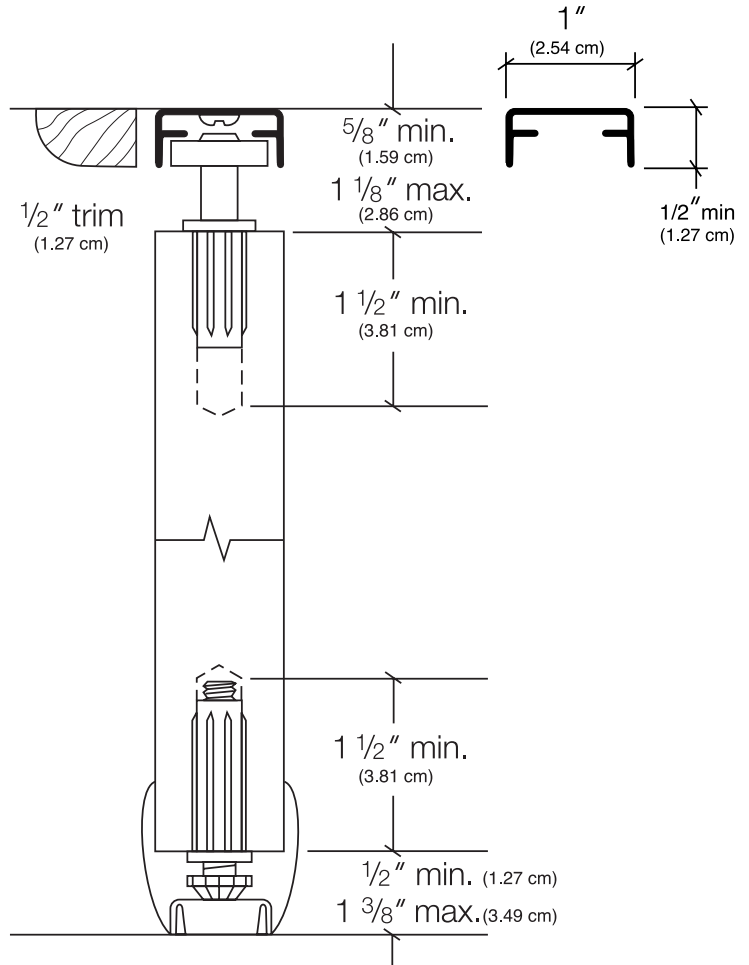

Complete Packaged Sets

RETAIL PACKAGING

Minimum 1" thick panels

Description	Set No.	Case Qty.	Case Weight	EDP Number
2 Door 24" opening	BF30-00-24	6 sets	9 lbs	40 2022
2 Door 30" opening	BF30-00-30	6 sets	10 lbs	40 2025
2 Door 36" opening	BF30-00-36	6 sets	12 lbs	40 2032
4 Door 48" opening	BF30-00-48	6 sets	19 lbs	40 2044
4 Door 60" opening	BF30-00-60	6 sets	21 lbs	40 2054
4 Door 72" opening	BF30-00-72	6 sets	24 lbs	40 2064



BiFold Hardware

BF30

Track with Pivot Bracket

Track No.	Number of Panels	Length	Finish	Case Qty.	Case Weight	EDP Number
BF30-01-24	2	23 3/4"	WHITE	25 EA.	14 LBS	52 2004 001
BF30-01-28	2	27 3/4"	WHITE	25 EA.	16 LBS	52 2024 001
BF30-01-30	2	29 3/4"	WHITE	25 EA.	17 LBS	52 2032 001
BF30-01-32	2	31 3/4"	WHITE	25 EA.	18 LBS	52 2052 001
BF30-01-36	2	35 3/4"	WHITE	25 EA.	19 LBS	52 2060 001
BF30-01-36	4	35 3/4"	WHITE	25 EA.	22 LBS	52 2064 001
BF30-01-48	4	47 3/4"	WHITE	25 EA.	28 LBS	52 2068 001
BF30-01-60	4	59 3/4"	WHITE	25 EA.	34 LBS	52 2092 001
BF30-01-72	4	71 3/4"	WHITE	25 EA.	40 LBS	52 2120 001
BF30-01-84	4	83 3/4"	WHITE	25 EA.	48 LBS	52 2144 001
BF30-01-96	4	95 3/4"	WHITE	25 EA.	54 LBS	52 2148 001

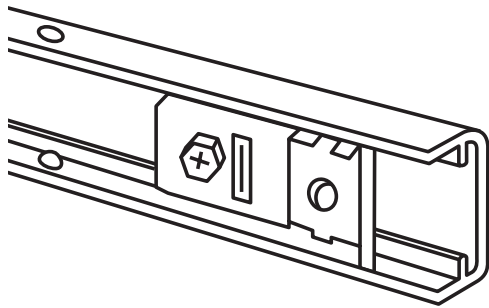

DIMPLED STEEL TRACK

Track No.	Number of Panels	Length	Finish	Case Qty.	Case Weight	EDP Number
BF30-02-24	2	23 3/4"	WHITE	25 EA.	14 LBS	52 2284 001
BF30-02-30	2	29 3/4"	WHITE	25 EA.	17 LBS	52 2300 001
BF30-02-36	2	35 3/4"	WHITE	25 EA.	19 LBS	52 2316 001
BF30-02-48	4	47 3/4"	WHITE	25 EA.	28 LBS	52 2320 001
BF30-02-60	4	59 3/4"	WHITE	25 EA.	34 LBS	52 2332 001
BF30-02-72	4	71 3/4"	WHITE	25 EA.	40 LBS	52 2344 001

Packaged Set Components

Steel Track EDP No.
BF30-01-XX **

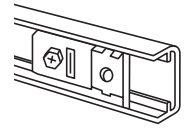

Snugger Case Qty. EDP No.
BF30-22- 2Door 200 ea. 52 2240 001
BF30-24- 4Door 100 ea. 52 2244 001

2 Door



4 Door

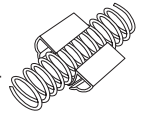

Top Guide Pivot/Guide Wheel – 7/16" Dia. Body

BF50-34-Top Pivot 200 ea. 52 2272 001
BF30-35-Guide Wheel 200 ea. 52 2280 001
BF30-36-Bottom Pivot 200 ea. 52 3248 001

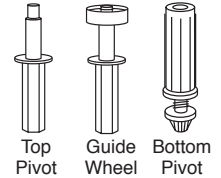

Jamb Bracket

BF30-81 200 pr. 52 4200 001

Easy horizontal adjustment

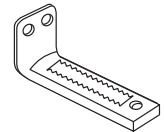

Aligners

BF50-72 100 pr. 52 2224 001

For use in four door installations

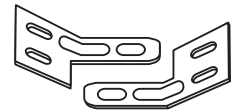

Knobs

BF50-62-Wood 100 pr. 52 1280 001



Wood

Hinges Length Case Qty. EDP No.

221-3-Offset Holes 3" 300 pr. 52 1032 001

Brass tone zinc finish

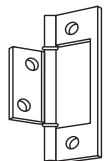

See next page for accessories

BiFold Hardware



BF30

Hardware

Accessories & Options

Pivot Bracket	Case Qty.	EDP No.
BF30-10	200 ea.	52 2236 001

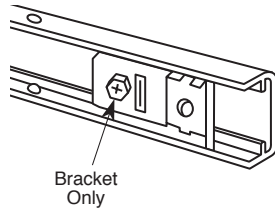

Top Guide Pivot/Guide Wheel – 3/8" Dia. Body		
BF30-31-Top Pivot	200 ea.	52 2612 001
BF30-32-Guide Wheel	200 ea.	52 2620 001
BF30-33-Bottom Pivot	200 ea.	52 4212 001

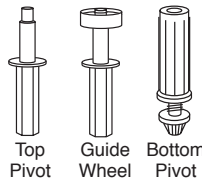

Slide Guides

BF30-25	200 ea.	52 2372 001
---------	---------	-------------

Cushions door when opening, tensions doors in closed position

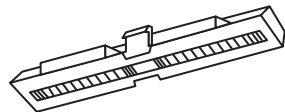

Jamb Bracket

BF50-81	200 ea.	52 2252 001
---------	---------	-------------

3/4" flat head screws
Easy horizontal adjustment

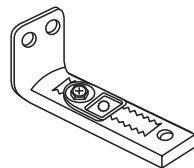

BF50-83	200 ea.	52 2264 001
---------	---------	-------------

Floor Bracket for slab floor installations

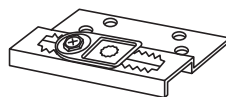

BF50-84	200 ea.	52 3236 001
---------	---------	-------------

3/4" flat head screws
Heavy Duty Jamb Bracket for mounting above floor

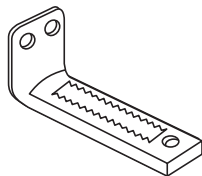

Knob

BF50-65 - Brass	400 pr.	52 1244 001
BF50-61 - Plastic	100 pr.	52 1280 001

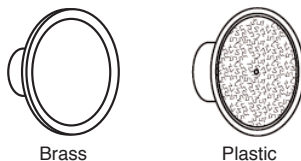

Hinges	Length	Case Qty.	EDP No.
220-3LS	3"	300 pr.	52 1016 001

Non-mortise, In-line holes, no screws

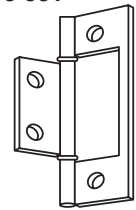

224- 2 1/2" x 1 5/8"	300 pr.	52 1052 001
----------------------	---------	-------------

Satin Brass Finish
Flatback Hinge, no screws

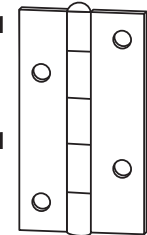

234- 2 1/2" x 1 5/8"	300 pr.	52 1076 001
----------------------	---------	-------------

Bright Zinc Finish Flatback
Hinge, no screws

224RC- 2 1/2" x 1 5/8"	300 pr.	52 1053 001
------------------------	---------	-------------

Satin Brass Finish Flatback
Hinge with raised countersinks for Medium Density Fiberboard (MDF) panels no screws

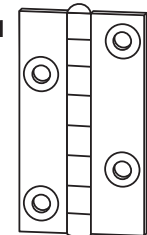

Screws	Case	EDP No.
220-121SC	600 sets	52 1024 001

Brass Tone Finish
Drill Point Screws for 220 hinge
#2 Phillips drive
#6 x 7/8" flat head



221-SC	600 sets	52 1040 001
--------	----------	-------------

Brass Tone Finish
Screws for 220-3/221-3 hinge
#2 Phillips drive
#6 x 7/8" flat head



214-121SC	300 sets	52 1004 001
-----------	----------	-------------

Brass Tone Finish
Self drilling screws for 224/234 hinge
#2 Phillips drive
#8 x 5/8" pan head



214-SC	300 sets	52 1000 001
--------	----------	-------------

Brass Tone Finish
Screws for 224/234 hinge
#2 Phillips drive
#8 x 5/8" pan head



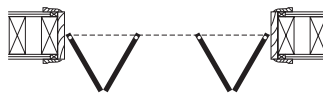

**When Ordering, Please Specify EDP Number
BF30 Bifolding Hardware Bagsets**

EPD No. Bagset Catalog No.	52 2007 001 2453	52 2011 001 2454	52 2012 001 2455	52 2015 001 2386
CLASS NO. PART DESCRIPTION				
BF30-83 Pivot Locator	1	1	1	
BF30-81 Bracket Jamb Blue Zinc	1	1	1	1
BF30-22 2-Door Snugger	1	1	1	
BF30-24 4-Door Snugger	1	1	1	
BF30-31 Top Pivot	2	1		
BF50-34 Top Pivot				2
BF30-33 Bottom Pivot	1	1	1	
BF30-36 Bottom Pivot				1
BF30-25 Slide Guide				1
BF30-32 Guide Wheel	1	1	1	
BF50-61 Plastic Knob Tan		1		
BF50-62 Wood Knob	1			
Plastic Knob White				1
BF50-72 Aligner	1	1	1	1
#8 x 5/8" Pan Head Screw	2	2	2	2
#8 x 1-1/2" Flat Head Screw	5	5	5	2
#8 x 3/4" Flat Head Screw	5	5	5	
#8 x 1-3/4" Truss Head Knob Screw	1	1		
#8 x 1-1/4" Pan Head Screw				3
#8 x 1-3/4" Truss Head Mach. Screw			1	

EPD No. Bagset Catalog No.	52 2017 001 2400	52 2492 001 2381-M	52 2528 001 2385	52 3128 001 2568	52 2016 001 2405
CLASS NO. PART DESCRIPTION					
BF30-83 Pivot Locator	1				1
BF30-81 Bracket Jamb Blue Zinc	1				1
BF50-81 Adjustable Jamb Bracket		1	1	2	
BF30-22 2-Door Snugger	1				1
BF30-24 4-Door Snugger	1			1	1
BF50-34 Top Pivot	1	2	2	2	1
BF30-36 Bottom Pivot	1	1	1	2	1
BF30-25 Slide Guide		1	1		
BF30-35 Guide Wheel	1			2	1
BF50-61 Plastic Knob Tan	1				
F50-62 Wood Knob				2	1
BF50-65 Brass Knob			1		
BF50-72 Aligner	1		1	2	1
#8 x 5/8" Pan Head Screw	2		2	4	2
#8 x 1-1/2" Flat Head Screw	5	5	5	10	5
#8 x 3/4" Flat Head Screw	5	5	5	10	5
#8 x 1-3/4" Truss Head Knob Screw	1			2	1
#8 x 1-1/4" Pan Head Screw			3		
#8 x 1-3/4" Truss Head Mach. Screw			1		
#8 x 1-9/16" Truss Head Knob Screw			1		

BiFold Hardware



BF50

50 lb. Panel Bifold

For installation of 2 or 4, 1" to 1 3/4" thick panels weighing up to 50 lbs. each, or multi-panels weighing up to 30 lbs. each.

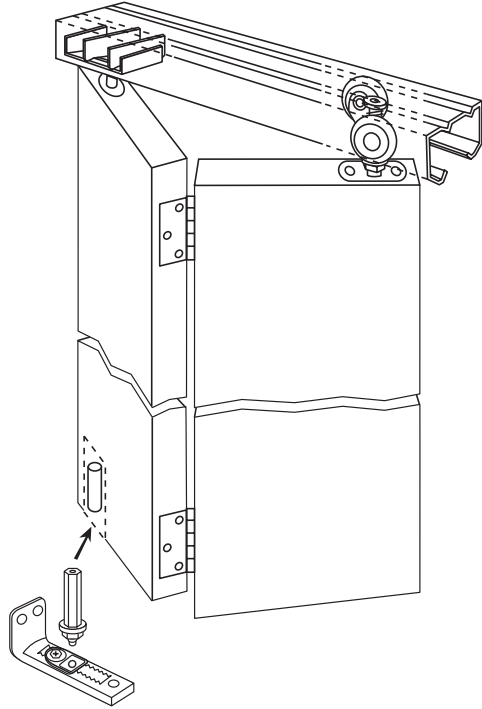

Features

- Extruded aluminum track
- Permanently lubricated 2-wheel roller carriage
- Spring loaded top pivot for easy installation
- All metal components galvanized against corrosion
- Quick, easy adjustments after installation
- Smooth, quiet operation

ANSI Reference

- BF50 conforms to ANSI A156.14 type D8621, D8642, D8652, D8662

Cross Reference

- STANLEY 2600 series • Crowder CF-115
- Grant 1600 • Hager 9570
- Johnson 111 FD • Lawrence HD 620/640
- Sterling 1570

Sizing Information

To determine panel width:

Panel width = known finished opening width divided by number of panels, less 1/4"

To determine opening width:

Opening width = known finished panel width plus 1/4", multiplied by number of panels

Door height = 2 3/8" less than finished opening height

Note: For multi-panel sizing information please contact factory.

Installation Detail

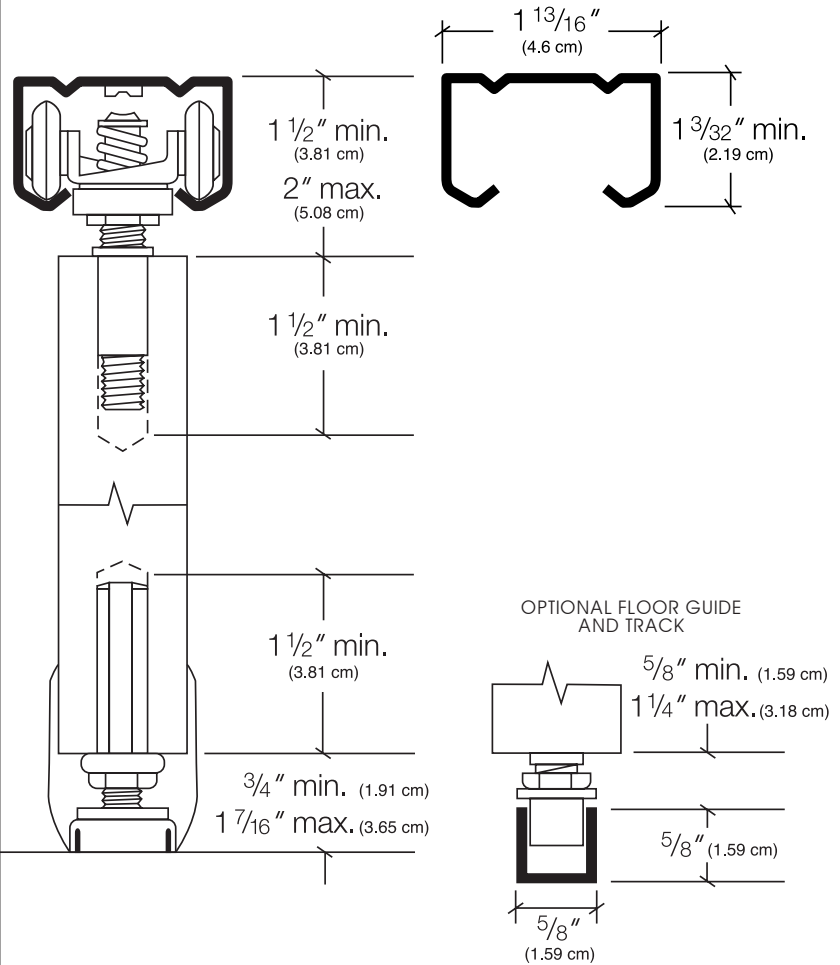

BF50 – Complete Packaged Sets

Description	Set No.	Case Qty.	Case Weight	EDP Number
2 Door 36" opening	BFC50-00-36	10 sets	16 lbs	40 2293 001
4 Door 48" opening	BFC50-00-48	10 sets	25 lbs	40 2294 001
4 Door 60" opening	BFC50-00-60	10 sets	28 lbs	40 2295 001
4 Door 72" opening	BFC50-00-72	10 sets	30 lbs	40 2296 001
4 Door 96" opening	BFC50-00-96	10 sets	38 lbs	40 2298 001

NOTE: Hinges not included in the set

Track

Track No.	Length	Finish	Case QTY.	Case WEIGHT	EDP Number
BF50-01-48	47 7/8"	ALUMINUM	10	13 LBS	40 2321 001
BF50-01-60	59 7/8"	ALUMINUM	10	16 LBS	40 2322 001
BF50-01-72	71 7/8"	ALUMINUM	10	19 LBS	40 2323 001
BF50-01-96	96"	ALUMINUM	10	24 LBS	40 2324 001
BF50-01-120	120"	ALUMINUM	10	32 LBS	40 2326 001
BF50-01-144	144"	ALUMINUM	10	36 LBS	40 2327 001
BF50-01-192	192"	ALUMINUM	10	52 LBS	40 2328 001

Packaged Set Components

Aluminum Track EDP No.

BF50-01-XX ** 

Pivot Bracket Case Qty. EDP No.

BF50-11 200 ea. 40 2304 001
Adjustable with wrench or screwdriver 

Snugger

BF50-22 100 ea. 40 2306 001 

Hanger

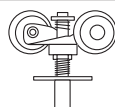
BF50-41 10 ea. 40 2303 001 
Two-wheel hanger with guide wheel

BF50-34 200 ea. 52 2272 001
Top Pivot 

BF50-33 200 ea. 52 2276 001 
Bottom Pivot

Jamb Bracket with Pivot Block

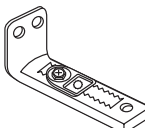
BF50-81 - 3/4" screws 200 ea. 52 2252 001 
Easy horizontal adjustment

Aligners

BF50-72 100 pr. 52 2224 001 
For use in four door installations

Adjusting Wrench

BP250-99 400 ea. 52 2232 001 

Knobs

BF50-62 - Wood 100 ea. 52 1280 001 
Wood

Accessories & Options

Hinges Case Qty. EDP No.

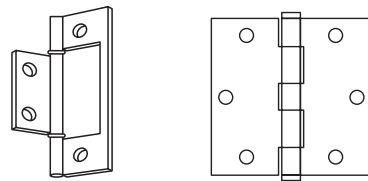

Jamb Brackets

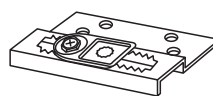
BF50-83 200 ea. 52 2264 001
Floor Bracket for slab floor installations 

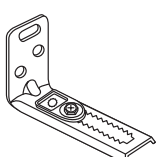
BF50-84 200 ea. 52 3236 001
3/4" flat head screws Heavy Duty Jamb Bracket for mounting above floor 

Floor Guide

BF125-71 10 ea. 40 2309 001
Adjustable high performance, lubricated, thermoplastic guide, 7/16" diameter shank For use with BF125-91 Track 

Floor Guide Track

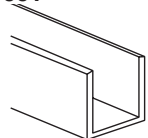
BF125-91 10 ea. 40 2310 001
5/8" x 5/8" x 8' Aluminum 

Knobs

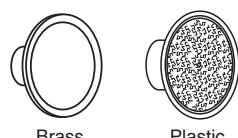
BF50-61 Plastic 100 ea. 52 1244 001
BF50-65 Brass 400 ea. 52 1236 001 
Brass Plastic

Hardware Set

BF50-HDW 10 sets 40 2308 001
Set includes 1 BF50-11 pivot bracket, 1 BF50-81 jamb bracket, 1 BF50-34 top pivot, 1 BF50-33 bottom pivot, 1 BF50-25 snugger accordion, 1 BF250-99 wrench, screws and instructions

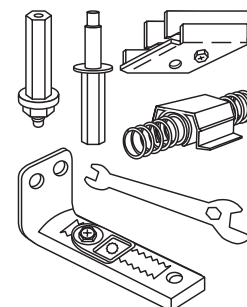

BiFold Hardware

BF125N

125 lb. Panel Bifold

For installation of 2 panels weighing up to 125 lbs. each or multi-panels weighing up to 75 lbs. each, 1 1/8" to 1 3/4" thick. For thicker panels, consult factory.

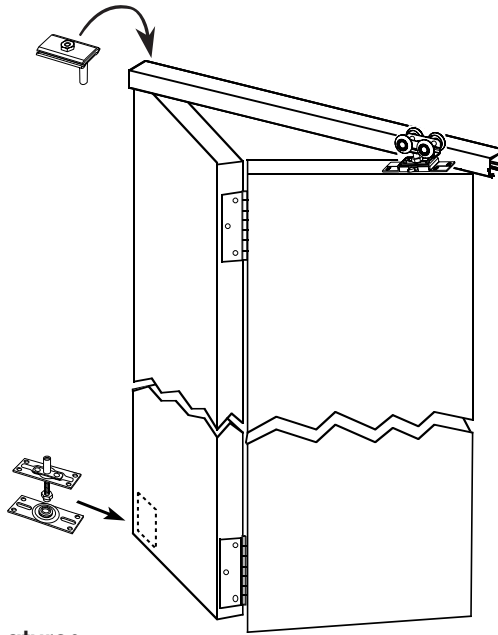

Features

- Large ball bearing wheels provide smooth action
- Easy-to-install snap-in feature makes hangers a "snap" to install
- Durable V-groove aluminum track provides smooth, quiet operation
- All metal components zinc plated to guard against corrosion
- Heavy duty pivot set designed for durability and aesthetics

ANSI Reference

- BF125N conforms to ANSI A156.14 type D8621, D8641, D8651, D8661

Cross Reference

- STANLEY 2700 series • Cox 42-200 • Grant 1260
- Hager 9870 • Johnson 200 FD/RD
- Lawrence 570 Track w/ED 620/640
- Sterling 1870



Sizing Information

To determine panel width:

Panel width = known finished opening width divided by number of panels, less 1/4"

To determine opening width:

Opening width = known finished panel width plus 1/4", multiplied by number of panels

Door height = 2 3/4" less than finished opening height

Note: For multi-panel sizing information please contact factory.

Installation Detail

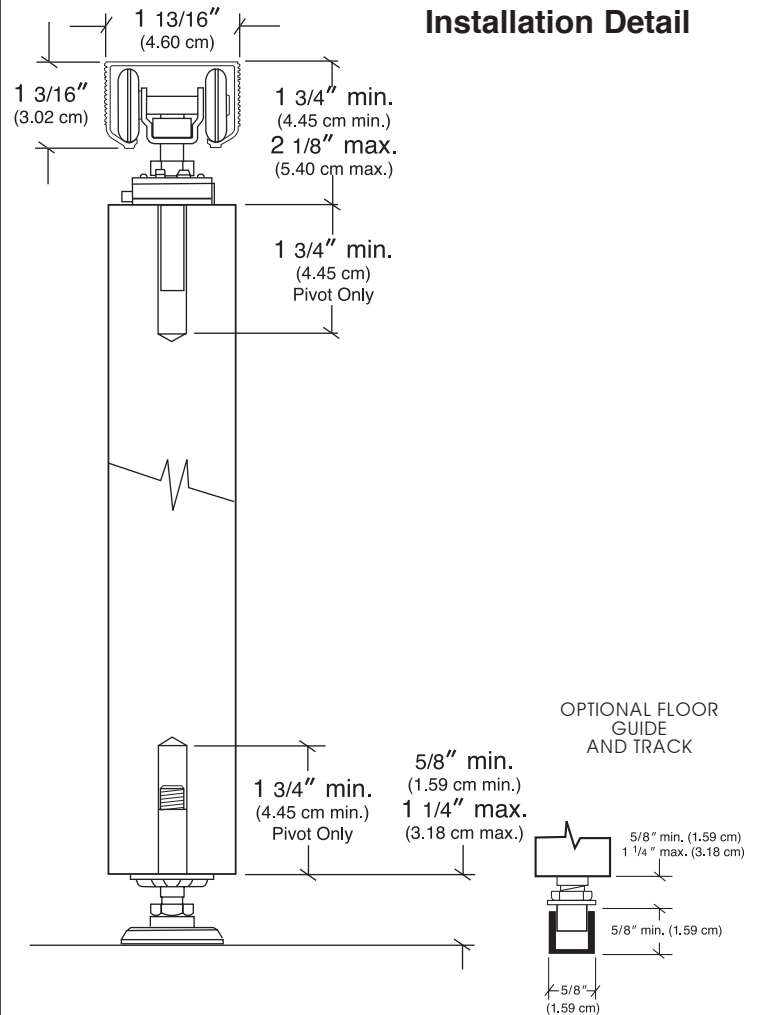

Complete Packaged Sets

Description	Set No.	Case Qty.	Case Weight	EDP Number
2 Door 30" opening	BF125N-00-30	6 sets	26 lbs	40 5225
2 Door 36" opening	BF125N-00-36	6 sets	26 lbs	40 5232
2 Door 48" opening	BF125N-02-48	6 sets	31 lbs	40 5242
4 Door 48" opening	BF125N-04-48	6 sets	46 lbs	40 5244
4 Door 60" opening	BF125N-00-60	6 sets	50 lbs	40 5254
4 Door 72" opening	BF125N-00-72	6 sets	54 lbs	40 5264
4 Door 96" opening	BF125N-00-96	6 sets	60 lbs	40 5284

Track

Track No.	Length	Finish	Case QTY.	Case Weight	EDP Number
BF125N-01-48	48"	ALUMINUM	10	13 LBS	40 5102 001
BF125N-01-60	60"	ALUMINUM	10	16 LBS	40 5103 001
BF125N-01-72	72"	ALUMINUM	10	29 LBS	40 5104 001
BF125N-01-96	96"	ALUMINUM	10	39 LBS	40 5105 001
BF125N-01-120	120"	ALUMINUM	10	47 LBS	40 5106 001
BF125N-01-144	144"	ALUMINUM	10	57 LBS	40 5107 001
BF125N-01-192	192"	ALUMINUM	10	78 LBS	40 5108 001

Packaged Set Components

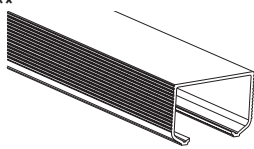
Aluminum Track	EDP No.
BF250N-01-XX V-grooved	** 

Snugger	Case Qty.	EDP No.
BF125N-21	100 ea.	52 4254 001

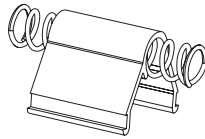

Top & Bottom Pivots Set	Case Qty.	EDP No.
BF125N-31 Fits into 1 3/4" deep, 3/8" diameter hole in door	10 sets	40 5302 001

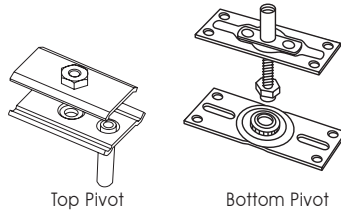

Top Pivot

Bottom Pivot

Hangers	Case Qty.	EDP No.
BF125N-41 Four large ball bearing wheels, easy installation feature	10 ea.	40 5301 001

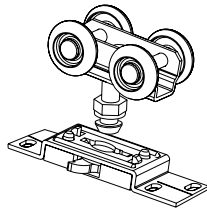

Hinges	Case Qty.	EDP No.
741 US4 Satin Brass Finish 3 1/2" x 3 1/2", with screws	50 pks.	08 2100

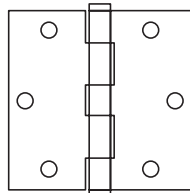

Adjustment Wrench	Case Qty.	EDP No.
BP250-99	400 ea.	52 2232 001



Floor Guide	Case Qty.	EDP No.
BF125-71 Adjustable, high performance, lubricated, thermoplastic guide 7/16" diameter shank For use with BF125-91 track	10 ea.	40 2309 001



Floor Guide Track	Case Qty.	EDP No.
BF125-91 Aluminum floor guide track 5/8" x 5/8" x 8'	10 ea.	40 2310 001

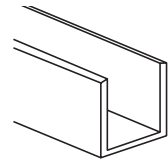

Hinges
F179/F191 CB179/CB191 FBB179/FBB191 1900R / 1960R CB1900R / CB1960R

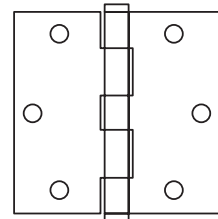

F179 Shown

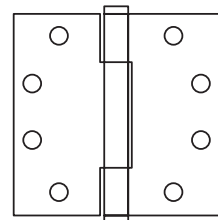

CB1900R Shown

ByPass Hardware

BP60 & BPD60

60lb. Panel ByPass

For installation of 2 By panels $3/4"$ to $1\ 3/8"$ thick, weighing up to 60 lbs. each

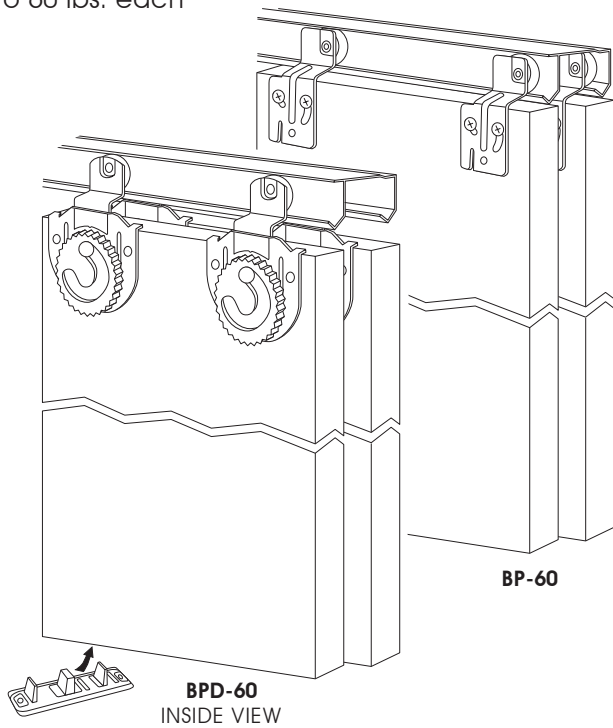

Track Detail

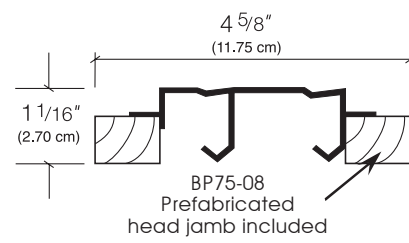
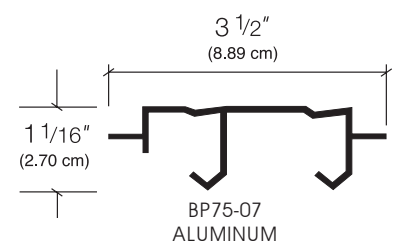
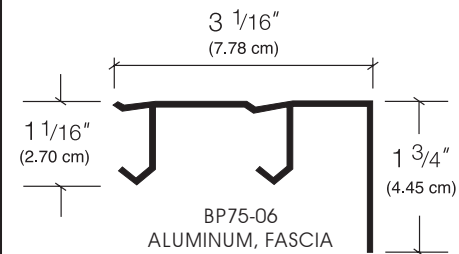
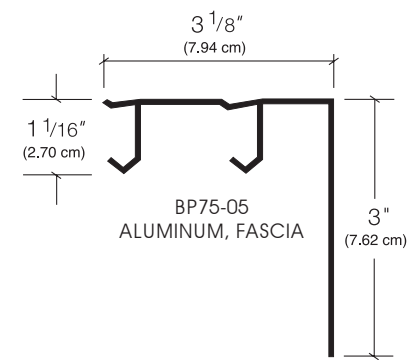
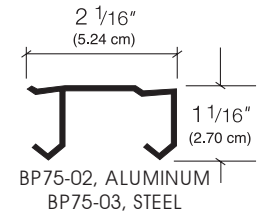
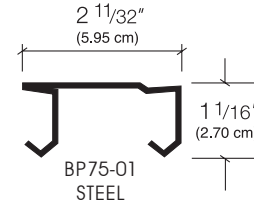

Features

- Hangers easy to adjust
- Self-aligning wheel system
- Permanently lubricated thermoplastic wheel
- Supports panels weighing up to 60 lbs
- Vertical adjustments can be made after installation
- Hanger system allows for easy panel removal
- V-groove galvanized steel or aluminum track provides smooth, quiet operation

ANSI Reference

- BPC60, BPC60A, BP60, BPD60, BPD60A conform to ANSI A156.14 type D8742; BPC60AF, BPD60AF conform to type D8752

Sizing Information

To determine panel width:

Panel width = known finished opening width plus 1" per overlap, divided by number of panels

To determine opening width:

Opening width = known finished panel width multiplied by number of panels, less 1" per overlap

Door height = 1 3/4" less than finished opening height

Installation Detail

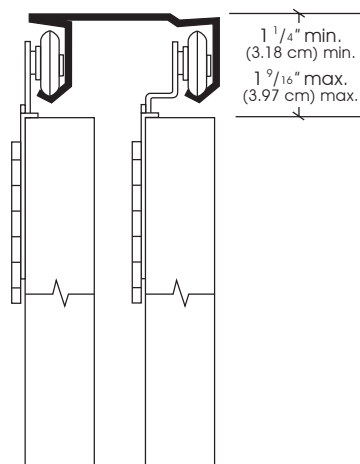

**Complete Packaged Sets
Slot Adjust**



CONTRACTOR Box Set with steel track BP75-01 For 1 3/8" thick doors only.

Description	Set No.	Case Qty.	Case Weight	EDP Number
2 Door 47" opening	BPC60-00-48	10 sets	26 lbs	40 3006 001
2 Door 59" opening	BPC60-00-60	10 sets	30 lbs	40 3008 001
2 Door 71" opening	BPC60-00-72	10 sets	35 lbs	40 3010 001
2 Door 95" opening	BPC60-00-96	10 sets	45 lbs	40 3012 001

CONTRACTOR Box Set w/aluminum track BP75-02 For 3/4" and 1 3/8" thick doors.

Description	Set No.	Case Qty.	Case Weight	EDP Number
2 Door 47" opening	BPC60A-00-48	10 sets	16 lbs	40 3020 001
2 Door 59" opening	BPC60A-00-60	10 sets	19 lbs	40 3021 001
2 Door 71" opening	BPC60A-00-72	10 sets	22 lbs	40 3022 001

RETAIL Box Set with steel track BP75-03 For 3/4" and 1 3/8" thick doors.

Description	Set No.	Case Qty.	Case Weight	EDP Number
2 Door 47" opening	BP60-00-48	6 sets	20 lbs	40 3040
2 Door 59" opening	BP60-00-60	6 sets	23 lbs	40 3050
2 Door 71" opening	BP60-00-72	6 sets	27 lbs	40 3060
2 Door 95" opening	BP60-00-96	6 sets	35 lbs	40 3080

Packaged Set Components

Single Wheel Hangers	Case Qty.	EDP No.
BP60-43 – 1/4" offset Includes 7 each 5/8" screws	50 per	54 1268 001
BP60-44 – 1/4" offset Includes 4 each 5/8" and 3 each 1-1/2" screws	50 per	54 1272 001
BP60-45 – 1/2" offset Includes 7 each 5/8" screws	50 per	54 1284 001
BP60-46 – 1/2" offset Includes 4 each 5/8" and 3 each 1-1/2" screws	50 per	54 1288 001



Floor Guide

BP150-71 – Zinc / White Adjustable for 3/4" to 1-3/8" thick bypassing doors	50 ea.	54 1008 001
---	---------------	--------------------

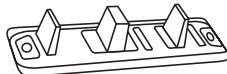

Pulls

BP150-61 Bright Brass 3/4" finger pull	200 ea.	52 1224 001
--	----------------	--------------------



**Complete Packaged Sets
Dial Adjust**



RETAIL Box Set with steel track BP75-03 For 3/4" and 1 3/8" thick doors.

Description	Set No.	Case Qty.	Case Weight	EDP Number
2 Door 47" opening	BPD60-00-48	6 sets	21 lbs	40 3140
2 Door 59" opening	BPD60-00-60	6 sets	25 lbs	40 3150
2 Door 71" opening	BPD60-00-72	6 sets	28 lbs	40 3160
2 Door 95" opening	BPD60-00-96	6 sets	36 lbs	40 3180

RETAIL Box Set with aluminum track BP75-02 For 3/4" and 1 3/8" thick doors.

Description	Set No.	Case Qty.	Case Weight	EDP Number
2 Door 47" opening	BPD60A-00-48	6 sets	16 lbs	40 3240 001
2 Door 59" opening	BPD60A-00-60	6 sets	18 lbs	40 3250 001
2 Door 71" opening	BPD60A-00-72	6 sets	20 lbs	40 3260 001

Packaged Set Components

Single Wheel Hangers	Case Qty.	EDP No.
BP60-41 – 7/16" offset #1 Finger adjustable, side mounted	100 ea.	54 1024 001
BP60-42 – 1/8" offset #2 Finger adjustable, side mounted	100 ea.	54 1028 001



Floor Guide

BP150-71 – Zinc / White Adjustable for 3/4" to 1-3/8" thick bypassing doors	50 ea.	54 1008 001
---	---------------	--------------------

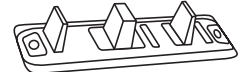

Pulls

BP150-61 Bright Brass 3/4" finger pull	20 ea.	52 1224 001
--	---------------	--------------------



Track

Track No.	Length	Finish	Case Qty.	Case Weight	EDP Number
BP75-01-48	46 1/2"	STEEL	10	18 LBS	54 1416 001
BP75-01-60	58 1/2"	STEEL	10	24 LBS	54 1420 001
BP75-01-72	70 1/2"	STEEL	10	29 LBS	54 1424 001
BP75-01-96	93 1/2"	STEEL	10	39 LBS	54 1436 001
BP75-01-120	120"	STEEL	10	51 LBS	54 1444 001
BP75-01-144	144"	STEEL	10	54 LBS	54 1448 001
BP75-02-48	46 3/8"	ALUMINUM	10	12 LBS	54 1232 001
BP75-02-60	58 3/8"	ALUMINUM	10	15 LBS	54 1236 001
BP75-02-72	70 3/8"	ALUMINUM	10	17 LBS	54 1240 001
BP75-02-96	93 3/8"	ALUMINUM	10	25 LBS	54 1248 001
BP75-02-144	144"	ALUMINUM	10	35 LBS	54 1264 001
BP75-03-48	46 3/8"	STEEL	10	18 LBS	59 3096 001
BP75-03-60	58 3/8"	STEEL	10	24 LBS	59 3100 001
BP75-03-72	70 3/8"	STEEL	10	29 LBS	59 3104 001

Track No.	Length	Finish	Case Qty.	Case Weight	EDP Number
BP75-05-48	46 7/8"	ALUMINUM	10	23 LBS	54 1456 001
BP75-05-60	58 7/8"	ALUMINUM	10	28 LBS	54 1460 001
BP75-05-72	70 7/8"	ALUMINUM	10	34 LBS	54 1464 001
BP75-05-96	94 7/8"	ALUMINUM	10	46 LBS	54 1472 001
BP75-05-120	120"	ALUMINUM	10	59 LBS	54 1476 001
BP75-06-48	48"	ALUMINUM	10	18 LBS	54 1488 001
BP75-06-60	60"	ALUMINUM	10	22 LBS	54 1492 001
BP75-06-72	72"	ALUMINUM	10	25 LBS	54 1496 001
BP75-06-96	96"	ALUMINUM	10	39 LBS	54 1504 001
BP75-06-144	144"	ALUMINUM	10	54 LBS	54 1512 001
BP75-07-48	46 7/8"	ALUMINUM	10	23 LBS	54 1368 001
BP75-07-60	58 7/8"	ALUMINUM	10	28 LBS	54 1372 001
BP75-07-72	70 7/8"	ALUMINUM	10	34 LBS	54 1376 001
BP75-08-48	46 7/8"	ALUMINUM	10	23 LBS	54 1384 001
BP75-08-60	58 7/8"	ALUMINUM	10	28 LBS	54 1388 001
BP75-08-72	70 7/8"	ALUMINUM	10	34 LBS	54 1392 001

See next page for accessories and options

ByPass Hardware

BP60 & BPD60

Twin Wheel Hangers Case Qty. EDP No.

BP75-43— 1/4" offset **50 pr.** **54 1296 001**
Twin wheel hanger, side mounted

BP75-45— 1/2" offset **50 pr.** **54 1304 001**
Twin wheel hanger, side mounted
For doors up to 75 lbs. each.

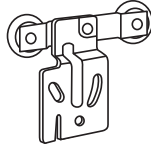

Angle Stop

BP250-75— Zinc **100 ea.** **54 1004 001**
Attaches to back of one panel to prevent panels from crossing

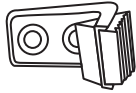

Center Stop

BP75-76 **40 3998 001**
Attaches to track to limit door travel

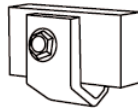

Accessories & Options

Pulls

BP250-61— Bright Brass **20 ea.** **52 1228 001**
2-1/8" Flush Pull

BP250-62— Antique Brass **100 ea.** **52 1240 001**
2-1/8" Flush Pull



Floor Guides

BP150-72— White **100 ea.** **54 1020 001**
Floor Guide, plastic, for 1-3/8" thick doors

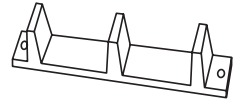

BP150-73— White **100 ea.** **54 1000 001**
Floor Guide, plastic, one pair/door

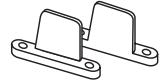

Carpet Riser

BP150-74— Zinc **50 ea.** **54 1016 001**
Carpet Riser provides 1/2" rise for Floor Guide BP150-71 and BP150-72



BP150-75— Zinc/White **50 ea.** **54 1012 001**
(BP150-71 50 per box bulk pack)
For 3/4" to 1 3/8" doors.

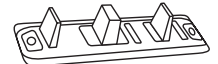

EDP No.		54 1292 8902-BX BP60-HDW-5	54 1252 8900-BX BP60-HDW-3
Bagset Catalog No.			
Class No.	Part Description		
BP60-46	1/2" Offset Hanger	4	2
BP60-44	1/4" Offset Hanger	-	2
BP150-72	Plastic Floor Guide	1	-
BP150-71	Adjustable Floor Guide	-	1
BP250-61	Brass Pull	2	-
BP150-62	Plastic Pull	-	2
	#8 x 5/8" Pan Head Screw	10	16
	#8 x 1-1/2" Pan Head Screw	6	10
	Instruction Sheet	1	1

How to Determine Hanger Combinations

3/4" Panels

TRACK	SLOT ADJUST HANGERS SINGLE WHEEL FRONT/REAR	SLOT ADJUST HANGERS TWIN WHEEL FRONT/REAR	DIAL ADJUST HANGERS FRONT/REAR
BP75-02	BP60-45/BP60-44	BP75-45/BP75-43	BP60-41/BP60-42
BP75-03	BP60-45/BP60-44	BP75-45/BP75-43	BP60-41/BP60-42

1" – 1 1/8" Panels

BP75-01	BP60-45/BP60-44	BP75-45/BP75-43	BP60-41/BP60-42
BP75-02	BP60-45/BP60-45	BP75-45/BP75-45	BP60-41/BP60-41
BP75-03	BP60-45/BP60-45	BP75-45/BP75-45	BP60-41/BP60-41
BP75-05	BP60-45/BP60-44	BP75-45/BP75-43	BP60-41/BP60-42
BP75-06	BP60-45/BP60-44	BP75-45/BP75-43	BP60-41/BP60-42
BP75-07	BP60-45/BP60-44	BP75-45/BP75-43	-
BP75-08	BP60-45/BP60-44	BP75-45/BP75-43	-

1 3/8" Panels

BP75-01	BP60-45/BP60-45	BP75-45/BP75-45	BP60-41/BP60-41
BP75-02	BP60-43/BP60-45	BP75-43/BP75-45	BP60-42/BP60-41
BP75-03	BP60-43/BP60-45	BP75-43/BP75-45	BP60-42/BP60-41
BP75-05	BP60-45/BP60-45	BP75-45/BP75-45	BP60-41/BP60-41
BP75-06	BP60-45/BP60-45	BP75-45/BP75-45	BP60-41/BP60-41
BP75-07	BP60-44/BP60-44	BP75-43/BP75-43	-
BP75-08	BP60-44/BP60-44	-	-

ByPass Hardware

BP150N & BP250N

For installation of 2 bypassing doors, with 1 3/8" to 1 3/4" thick panels

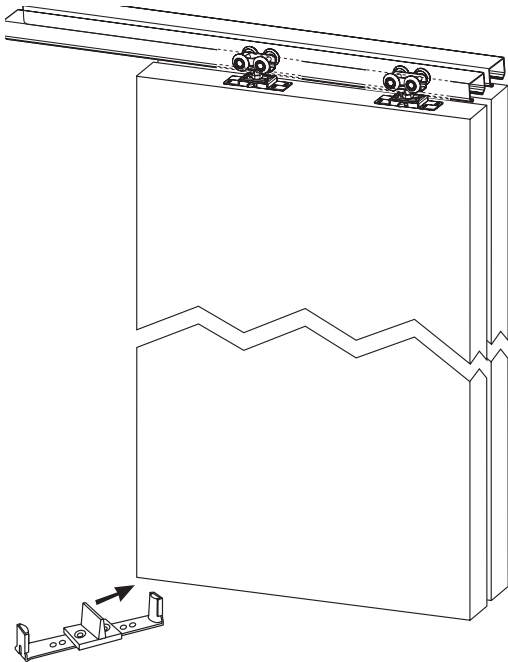

Features

- BP150N supports panels weighing up to 150 lbs
- BP250N supports panels weighing up to 250 lbs
- Large 1" wheels provide smooth action
- Easy-to-install snap-in feature makes hangers a "snap" to install. Vertical adjustments can be made after installation.
- Durable V-groove aluminum track provides smooth, quiet operation
- Track spacer allows for easy installation of 1 3/4" bypass and tri-pass doors

ANSI Reference

- BPC150N and BPC250N conform to ANSI A156.14 type D8731
- Above with Fascia conform to ANSI A156.14 type D8751

Cross Reference—BP150N

- STANLEY 1700 series • Cox 15 • Crowder C-500
- Grant 7000 • Hager 9602 • Sterling 1754
- Lawrence 581 Track w/HD520

Cross Reference—BP250N

- STANLEY-57/58 • Crowder C-103-4
- Grant 1200 • Hager 9875
- Lawrence - F571/ED520 • Sterling 1876



150 lb. & 250 lb. Panel ByPass

Sizing Information

To determine panel width:

Panel width = known finished opening width plus 1" per overlap divided by number of panels

To determine opening width:

Opening width = known finished panel width multiplied by number of panels, less 1" per overlap

Door height = 2 5/8" less than finished opening height

Installation Detail

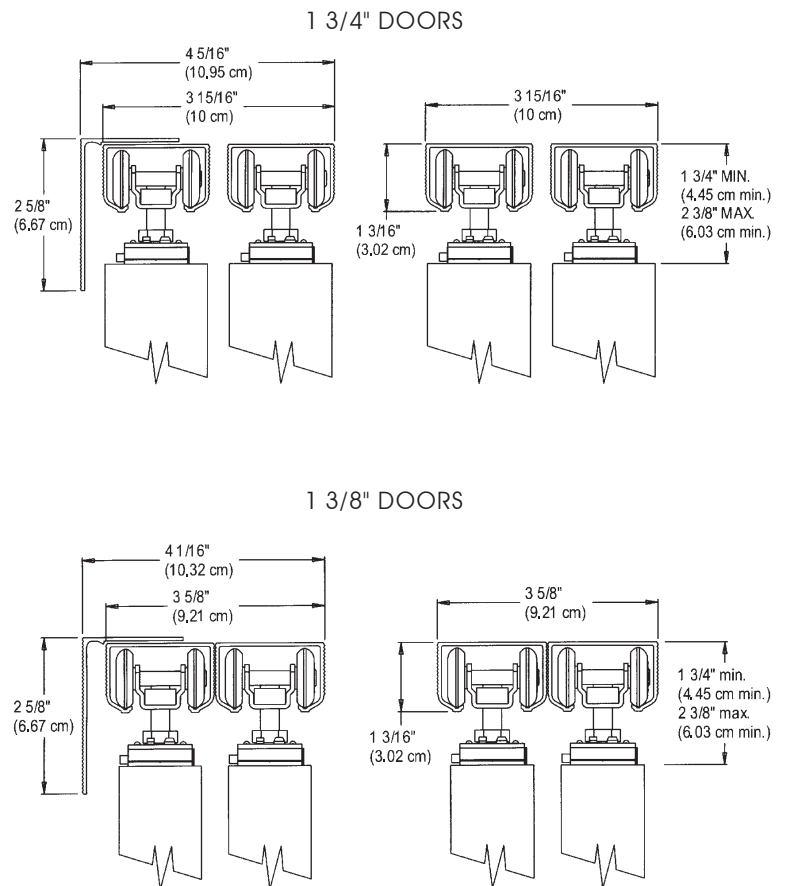

Complete Packaged Sets

150 lb.

CONTRACTOR Box Set with BP150N – 41 Hangers

Description	Set No.	Case Qty.	Case Weight	EDP Number
2 Door 48" opening	BPC150N-00-48	6 sets	22 lbs	40 5664
2 Door 60" opening	BPC150N-00-60	6 sets	25 lbs	40 5665
2 Door 72" opening	BPC150N-00-72	6 sets	28 lbs	40 5666
2 Door 96" opening	BPC150N-00-96	6 sets	34 lbs	40 5668

250 lb.

CONTRACTOR Box Set with BP250N – 41 Hangers

Description	Set No.	Case Qty.	Case Weight	EDP Number
2 Door 60" opening	BPC250N-00-60	6 sets	48 lbs	40 5750
2 Door 72" opening	BPC250N-00-72	6 sets	53 lbs	40 5760
2 Door 96" opening	BPC250N-00-96	6 sets	63 lbs	40 5780

BP150N & BP250N

Accessories & Options

Track

Track No.	Length	Finish	Case QTY.	Case Weight	EDP Number
BP250N-01-48	48"	ALUMINUM	10	13 LBS	40 5102 001
BP250N-01-60	60"	ALUMINUM	10	16 LBS	40 5103 001
BP250N-01-72	72"	ALUMINUM	10	29 LBS	40 5104 001
BP250N-01-96	96"	ALUMINUM	10	39 LBS	40 5105 001
BP250N-01-120	120"	ALUMINUM	10	47 LBS	40 5106 001
BP250N-01-144	144"	ALUMINUM	10	57 LBS	40 5107 001
BP250N-01-192	192"	ALUMINUM	10	78 LBS	40 5108 001

Fascia

Track No.	Length	Finish	Case QTY.	Case Weight	EDP Number
BP250N-02-48	48"	ALUMINUM	10	24 LBS	40 5200 001
BP250N-02-60	60"	ALUMINUM	10	30 LBS	40 5201 001
BP250N-02-72	72"	ALUMINUM	10	35 LBS	40 5202 001
BP250N-02-96	96"	ALUMINUM	10	35 LBS	40 5203 001
BP250N-02-120	120"	ALUMINUM	10	35 LBS	40 5204 001

Packaged Set Components

Aluminum Track EDP No.

BP250N-01-XX **



Aluminum Fascia EDP No.

BP250N-02-XX **



Track Spacer Case Qty. EDP No.

BP250N-00 10 sets 40 5306 001

For 1 3/4" doors

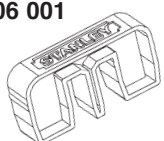

Hanger EDP No.

BP150N-41 20 pr. 40 5304 001

Four large wheels, easy installation feature
Packaged with BP150N-00

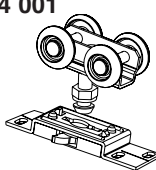

Hanger EDP No.

BP250N-41 5 pr. 40 5305 001

Four large, ball-bearing wheels, easy installation feature
Packaged with BP250N-00

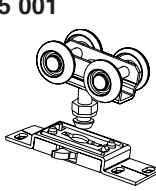

Floor Guide EDP No.

BP250N-71 50 ea. 40 3534 001

Adjustable for 1 3/8" to 1 3/4" thick bypassing doors

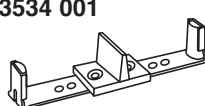

Adjusting Wrench EDP No.

BP250-99 400 ea. 52 2232 001

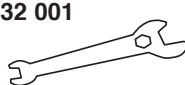

Angle Stop Case Qty. EDP No.

BP250-75 – Zinc 100 ea. 54 1004 001

Attaches to back of one panel to prevent panels from crossing



Center Stop EDP No.

BP250-77 – Zinc 20 ea. 40 0004 001

Attaches to track to limit panel travel

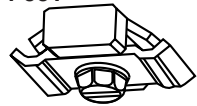

Pulls EDP No.

BP150-61 – Bright Brass 200 ea. 52 1224 001

3/4" Finger Pull 

BP250-61 – Bright Brass 20 ea. 52 1228 001

2 1/8" Flush Pull 

BP250-62 – Antique Brass 100 ea. 52 1240 001

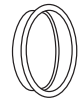
2 1/8" Flush Pull 

Hanger Sets EDP No.

BP150N-HDW 10 sets 440 5860 001

Set contains (2) BP250N-43 hanger plates, (2) BP150N-41 ball bearing hangers, (1) BP250-99 wrench and (1) BP250-71 floor guide. (For doors weighing up to 150 lbs. each)

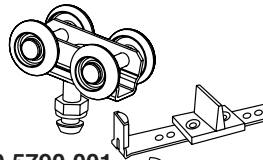

BP250N-HDW 10 sets 40 5790 001

Set contains (2) BP250N-43 hanger plates, (2) BP250N-41 ball bearing hangers, (1) BP250-99 wrench and (1) BP250-71 floor guide. (For doors weighing up to 250 lbs. each)

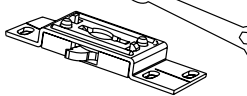

Floor Guides Case Qty. EDP No.

BP150-71 – Zinc/White 50 ea. 54 1008 001

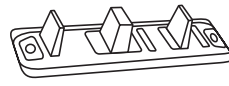
Adjustable for 3/4" to 1 3/8" thick bypassing doors 

BP150-75 – Zinc/White 50 ea. 54 1012 001

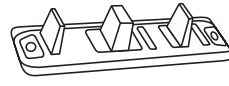
Adjustable for 3/4" to 1 3/8" thick bypassing doors 

BP150-72 – White 100 ea. 54 1020 001

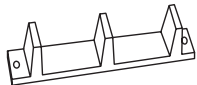
Floor Guide, plastic, for 1 3/8" thick doors 

BP150-73 – White 100 ea. 54 1000 001

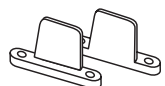
Floor Guide, plastic, one pair/door 

Carpet Riser EDP No.

BP150-74 – Zinc 50 ea. 54 1016 001

Carpet Riser provides 1/2" rise for Floor Guides BP150-71 and BP150-72

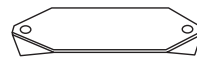

Pocket Door Hardware

PD75

75 lb. Panel – Pocket Door

For installation of pocket or bi-parting doors, with 3/4" to 1 3/4" thick panels weighing up to 75 lbs. each.

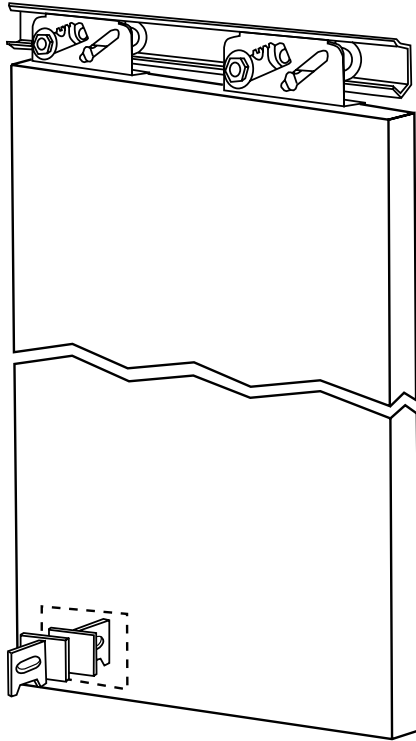

Installation Detail

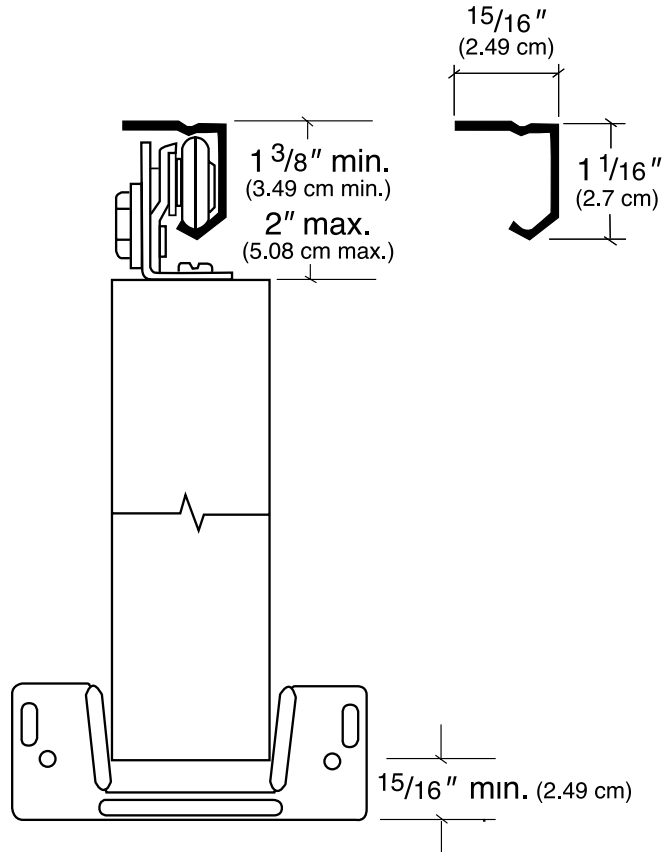

Features

- Self-aligning wheel system
- Permanently lubricated 2-wheel hangers
- Supports panels weighing up to 75 lbs
- Easy adjustment after installation
- Roll-formed galvanized jump proof steel track





ANSI Reference

- PD75 conforms to ANSI A156.14 types D8691, D8721

Cross Reference

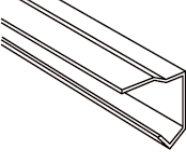
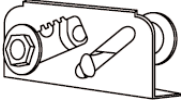
- STANLEY 84/85 series • Crowder C-300/350
- Grant 5075 • Johnson 2800

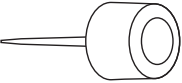
Packaged Set Components

	Single Track	Hanger	Bottom Guide	Bumper Stop	Adjusting Wrench	EDP No.
	PD75-01 V-groove jump proof track Not available separately					**
		BP75-41 Not available separately	PD250-71 Adjustable to center door in pocket	PD250-77 Stop and nail		40 3530 001
						40 3969 001
						52 2232 001

Complete Packaged Sets

RETAIL Box Set with steel track PD75-01

Description	Set No.	Case Qty.	Case Weight	EDP Number
1 Door 36" opening	PD75-00-36	6 sets	18 lbs	40 3903

PD150N

150 lb. Panel – Pocket Door

For installation of pocket or bi-parting doors, with 1" to 1 3/4" thick panels weighing up to 150 lbs. each.

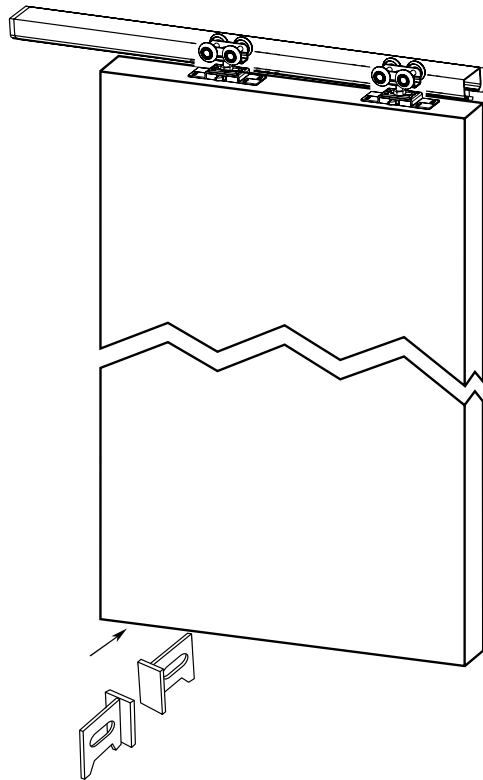

Features

- Four large 1" wheels for easy rolling action
- Easy-to-install feature makes installation a "snap"
- Supports panels weighing up to 150 lbs
- Easy adjustment after installation
- Cut marks on header make for easy sizing
- V-groove jump proof track

ANSI Reference

- PD150N conforms to ANSI A156.14 type D8681, D8711

Cross Reference

- STANLEY 1750 • Cox 15-200 • Crowder C-411
- Grant 5150 • Hager 9601w/9606 • Sterling 1601

Complete Packaged Sets

CONTRACTOR Box Set with aluminum track PD250N-01

Description	Set No.	Case Qty.	Case Weight	EDP Number
36" opening	PDC150N-00-36	6 sets	17 lbs	40 5843
48" opening	PDC150N-00-48	6 sets	21 lbs	40 5844

Installation Detail

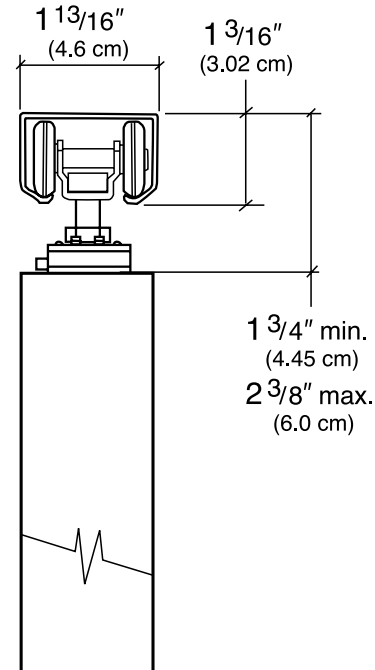

Packaged Set Components

Aluminum	EDP No.
PD250N-01-xx V-groove jump proof track	**
Hanger	
BP150N-41	40 5304 001
Bottom Guide	
PD250-71 Adjustable to center door in pocket	40 3530 001
Bumper Stop	
PD250-77 Stop and nail	40 3969 001
Adjusting Wrench	
BP250-99	52 2232 001

Replacement Hardware

Hardware Set	EDP No.
PD150N-HDW Set includes 2 BP150N-41 hangers, 1 PD250-74 door guide, 1 BP250-99 wrench, 1 PD250-77 bumper stop, nails, screws, and instructions	40 5845 001

See page 23 for Accessories and Options

Pocket Door Hardware

PDF150N & PDF250N

150lbs & 250lbs Panel Pocket Frames

PDF150N - For installation of pocket or bi-parting doors up to 3' wide and up to 8' high, weighing up to 150 lbs each

PDF250N - For installation of pocket or bi-parting doors up to 4' wide and up to 8' high, weighing up to 250 lbs each

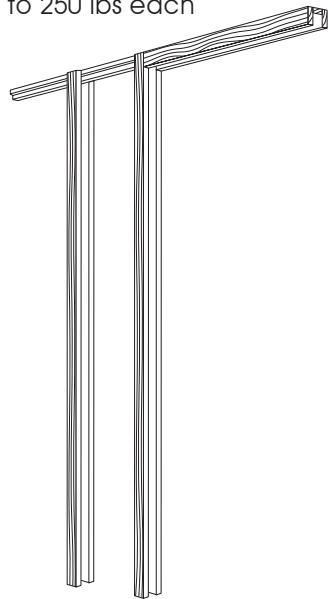

Features

- Steel wrap around stiffener reinforced split jambs
- Four large 1" wheels for easy rolling action
- PDF150N Supports panels weighing up to 150 lbs
- PDF250N Supports panels weighing up to 250 lbs
- Easy-to-install feature makes installation a "snap"
- V-groove jump proof track
- Cut marks on header for easy sizing

ANSI Reference

All conform to ANSI A156.14 type D8671, D8701

Cross Reference

PDF150N • Crowder Crowderframe • Hager 9629

- Sterling 1630 BB

PDF250N • Hager 9850 • Lawrence PF619

- Sterling 1840

PDF150N – Complete Packaged Sets

CONTRACTOR Box Set

Description	Set No.	Case Qty.	Case Weight	EDP Number
3' x 6'8" opening	PDFC150N-00-68	1 set	26 lbs	40 3925
3' x 7'0" opening	PDFC150N-00-70	1 set	31 lbs	40 5940 001
3' x 8'0" opening	PDFC150N-00-80	1 set	35 lbs	40 5942 001

PDF250N – Complete Packaged Sets

CONTRACTOR Box Set

Description	Set No.	Case Qty.	Case Weight	EDP Number
4' x 8'0" opening	PDFC250N-00	1 set	39 lbs	40 5950 001



Sizing Information

Finished Rough Opening

Opening Width = Door width multiplied by 2, add 1 1/4"
For Bi Part – Sum of 2 Doors, multiplied by 2, add 1 1/4"

PDF150N kits are sized for 3'0" door and PDF250N kits are sized for 4'0" door. Both can be cut down to accommodate smaller door widths.

Kits are sized for 6'8", 7'0" or 8'0" door height and can be cut shorter at installation

Rough Opening Height for Single Doors



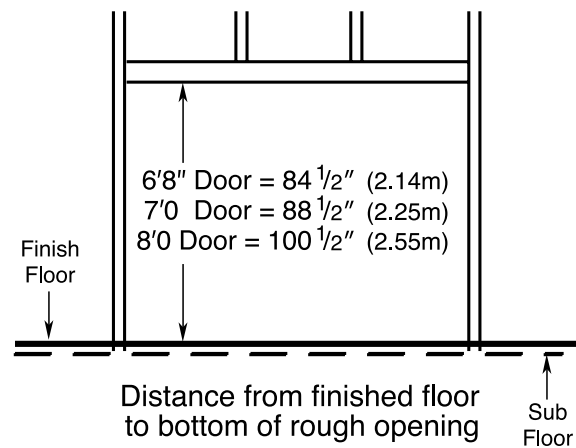

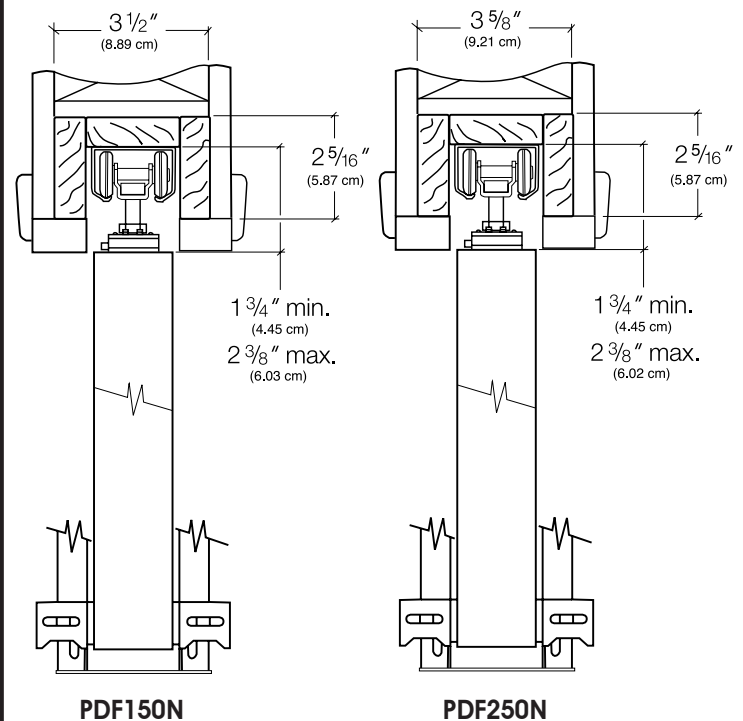

For bi-parting application refer to installation instructions



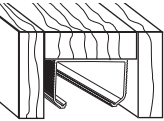
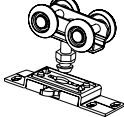

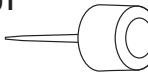
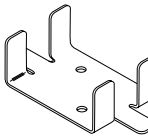



Installation Detail

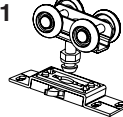

PD150N – Packaged Set Components

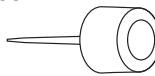
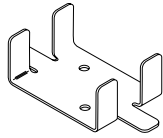
Aluminum Header Track	EDP No.	
PD250N-01 Not available separately	**	
Hanger	Case Qty.	EDP No.
BP150N-41 Four large wheels, easy installation feature	100 ea.	40 5304 001
		
Door Guide		
PD250-71 Adjustable to center door in pocket	100 ea.	40 3530 001
		
Bumper Stop		
PD250-77 Stop and nail	100 ea.	40 3969 001
		
Base Plates		
PDF150-75 Not available separately		
Adjusting Wrench		
BP250N-99	400 ea.	52 2232 001
		
End Bracket		
PDF150-05 Not available separately		
Split Stud Uprights		
PDF150-51 Not available separately		

PD250N – Packaged Set Components

Aluminum Header Track	EDP No.	
PDF250N-01 Not available separately	**	
Hanger	Case Qty.	EDP No.
BP250N-41 Four large ball-bearing wheels, easy installation feature	50 pr.	40 5305 001
		
Door Guide		
PD250-71 Adjustable to center door in pocket	100 ea.	40 3530 001
		
Bumper Stop		
PD250-77 Stop and nail	100 ea.	40 3969 001
		
Base Plates		
PDF250-75 Not available separately		
Adjusting Wrench		
BP250-99	400 ea.	52 2232 001
		
End Bracket		
PDF250-05 Not available separately		
Split Stud Uprights		
PDF250-51 Not available separately		

Pulls (for use on 1 3/8" thick doors)	EDP No.
PD150-61 2 3/4" Pull brass	40 4000
PD150-62 (for use on 1 3/8" thick doors) 2 3/4" Privacy lock, brass 2 3/4" Privacy lock, antique brass	40 4010 001 40 4012 700
Pulls (for use on 1 3/8" to 1 3/4" thick doors)	EDP No.
PD250-61 3 3/4" Pull brass	40 4030
PD250-62 (for use on 1 3/8" to 1 3/4" thick doors) 3 3/4" Privacy lock, brass	40 4040
PD250-63 Edge Pull brass	52 1272 001
PD250-64 2 3/4" x 1 5/16" x 3/8" Flush Pull brass	52 1276 001
PD250-05 Bi-parting bracket with center stops	40 5960 001



Accessories & Options	
	EDP No.
Jamb Stiffener	
PD250-95-81 81 3/4" Slotted Steel Stiffener	40 3963 001
PD250-95-97 97 3/4" Slotted Steel Stiffener	40 3965 001
PD250-96 81 3/4" Plain Steel Stiffener	40 3966 001
PD250-96P 81 3/4" Painted Steel Stiffener	40 3967 001
Center Stop	EDP No.
BP250-77 Zinc Attaches to track to limit panel travel	40 0004 001
Door Guide	EDP No.
PD250-74 Adjusts to center door in pocket for 1 3/8" doors	40 3993 001
PD250-72 Adjusts to center door in pocket for 1 3/4" doors	40 3997 001
Jamb Spacer	EDP No.
BP250-98	40 3996 001

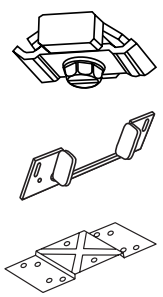



Stanley Hardware

A Division of Stanley Security Solutions, Inc.
6161 E. 75th Street Indianapolis, Indiana 46250
www.stanleysecuritysolutions.com



Security Solutions

Stanley Security Solutions, Inc.
6161 E. 75th Street Indianapolis, Indiana 46250
www.stanleysecuritysolutions.com