



Inset Cabinetry

crafted by

STARMARK[®]
C A B I N E T R Y

To best illustrate the profiles, each door is shown in Maple finished in Natural.
 The available wood types and price columns are listed below the photo, in the third row of information.



New!

ADDISON



Standard slab drawer header
Beaded inset



Optional five-piece drawer header
Flush inset

Addison door style in Maple finished in Natural
 Standard slab drawer header | Flush inset
 A12 | C12 | M12 | Q12 | RA12



ALLENTOWN



Standard slab drawer header
Beaded inset



Optional five-piece drawer header
Beaded inset



Optional profiled drawer header
Flush inset

Allentown door style in Alder finished in Natural with Chocolate glaze with Cottage Distressing
 Standard slab drawer header | Flush inset
 A12 | C12 | L12 | M11 | Q12 | RA12

timeless craftsmanship
inset door styles



Alexandria door style in Lyptus finished in Driftwood with Ebony glaze | Standard slab drawer header | Flush inset
A12 | C12 | L12 | M11 | Q12 | RA12

ALEXANDRIA



Standard slab drawer header
Beaded inset



Optional five-piece drawer header
Flush inset



Amsdahl door style in Cherry finished in Rye
Standard slab drawer header | Flush inset
A12 | C12 | L12 | M11 | Q12 | RA12

AMSDAHL



Standard slab drawer header
Beaded inset



Optional five-piece drawer header
Flush inset

To best illustrate the profiles, each door is shown in Maple finished in Natural. The available wood types and price columns are listed below the photo, in the third row of information.

To best illustrate the profiles, each door is shown in Maple finished in Natural.
The available wood types and price columns are listed below the photo, in the third row of information.



New!

ANNABELLA



Standard slab drawer header
Flush inset



Optional five-piece drawer header
Beaded inset

Annabella door style in Maple finished in Natural
Optional five-piece drawer header | Flush inset
A11 | C11 | M11 | Q12 | RA11



New!

BALLINGER



Standard slab drawer header
Flush inset



Optional five-piece drawer header
Beaded inset

Ballinger door style in Maple finished in Natural
Optional five-piece drawer header | Flush inset
A12 | C12 | M12 | Q12 | RA12

timeless craftsmanship

inset door styles



New!

CAMBRIDGE



Standard slab drawer header
Flush inset



Optional five-piece drawer header
Beaded inset

Cambridge door style in Maple finished in Natural
Optional five-piece drawer header | Flush inset
A12 | C12 | M12 | Q12 | RA12



CHARLOTTE



Standard slab drawer header
Flush inset



Optional five-piece drawer header
Beaded inset

Charlotte door style in Walnut finished in Natural
Optional five-piece drawer header | Flush inset
A11 | C11 | L11 | M11 | Q12 | RA11 | W12+25%

To best illustrate the profiles, each door is shown in Maple finished in Natural.
 The available wood types and price columns are listed below the photo, in the third row of information.



New!

CLAYMONT



Standard slab drawer header
Beaded inset



Optional five-piece drawer header
Flush inset

Claymont door style in Maple finished in Natural
 Standard slab drawer header | Flush inset
 A11 | C11 | M11 | Q12 | RA11 | W12+25%



DANBURG



Standard slab drawer header
Beaded inset



Optional five-piece drawer header
Flush inset



Optional profiled drawer header
Beaded inset

Danburg door style in Quarter Sawn Oak finished in Marshmallow Cream with Chocolate glaze | Standard slab drawer header | Flush inset
 A11 | C11 | L11 | M11 | Q11 | RA11 | W12+25%

timeless craftsmanship
inset door styles



DEWITT



Standard slab drawer header
Beaded inset



Optional five-piece drawer header
Flush inset

DeWitt door style in Maple finished in Villa Mushroom
Optional five-piece drawer header | Flush inset
A11 | C11 | L11 | M11 | Q11 | RA11 | W12+25



New!

EVARO



Standard slab drawer header
Beaded inset



Optional five-piece drawer header
Flush inset

Evvaro door style in Maple finished in Natural
Optional five-piece drawer header | Flush inset
A11 | C11 | M11 | Q12 | RA11

To best illustrate the profiles, each door is shown in Maple finished in Natural.
 The available wood types and price columns are listed below the photo, in the third row of information.



FAIRHAVEN



Standard slab drawer header
 Flush inset



Optional five-piece drawer header
 Beaded inset

Fairhaven door style in Rustic Alder finished in Slate
 Optional five-piece drawer header | Beaded inset
 A11 | C11 | L11 | M11 | Q11 | RA11 | W12+25%



GILLETTE



Standard slab drawer header
 Beaded inset



Optional five-piece drawer header
 Flush inset

Gillette door style in Maple finished in Dove with Latté
 glaze | Standard slab drawer header | Flush inset
 A11 | C11 | L11 | M11 | Q11 | RA11 | W12+25%

timeless craftsmanship

inset door styles



Kingsberry door style in Walnut finished in Natural
Optional profiled drawer header | Beaded inset
A11 | C11 | L11 | M11 | Q11 | RA11 | W12+25%

KINGSBERRY



Standard slab drawer header
Flush inset



Optional five-piece drawer header
Beaded inset



Optional profiled drawer header
Flush inset



Knottingham door style in Rustic Alder finished in Toffee with Chocolate glaze and Old World Distressing
Optional five-piece drawer header | Flush inset
A11 | C11 | L11 | M11 | Q11 | RA11 | W12+25%

KNOTTINGHAM



Standard slab drawer header
Flush inset



Optional five-piece drawer header
Beaded inset

To best illustrate the profiles, each door is shown in Maple finished in Natural.
 The available wood types and price columns are listed below the photo, in the third row of information.



Lafayette door style in Cherry finished in Chateaux
 Brittany | Standard slab drawer header | Flush inset
 A11 | C11 | L11 | M11 | Q11 | RA11

LAFAYETTE



Standard slab drawer header
 Beaded inset



Optional five-piece drawer header
 Flush inset



Lafontaine door style in Quarter Sawn Oak
 finished in Chestnut | Optional five-piece
 drawer header | Flush inset
 A11 | C11 | L11 | M11 | Q11 | RA11 | W12+25%

LAFONTAINE



Standard slab drawer header
 Flush inset



Optional five-piece drawer header
 Beaded inset

timeless craftsmanship

inset door styles



Laforest door style in Cherry finished in Natural
Optional profiled drawer header | Beaded inset
A11 | C11 | L11 | M11 | Q11 | RA11 | W12+25%

LAFOREST



Standard slab drawer header
Beaded inset



Optional five-piece drawer header
Flush inset



Optional profiled drawer header
Flush inset



Liberty door style in Maple finished in Natural
Optional five-piece drawer header | Flush inset
A11 | C11 | M11 | Q12 | RA11 | W12+25%

LIBERTY



Standard slab drawer header
Flush inset



Optional five-piece drawer header
Beaded inset

To best illustrate the profiles, each door is shown in Maple finished in Natural.
 The available wood types and price columns are listed below the photo, in the third row of information.



Mackay door style in Lyptus finished in Mocha with Ebony glaze | Standard slab drawer header | Flush inset

A11 | C11 | L11 | M11 | Q11 | RA11 | W12+25%

MACKAY



Standard slab drawer header
Flush inset



Optional five-piece drawer header
Beaded inset



Merrimac door style in Maple finished in Butterscotch | Standard slab drawer header | Flush inset

A11 | C11 | L11 | M11 | Q11 | RA11 | W12+25%

MERRIMAC



Standard slab drawer header
Beaded inset



Optional five-piece drawer header
Flush inset



Optional profiled drawer header
Beaded inset

timeless craftsmanship

inset door styles



MONTICO



Standard slab drawer header
Beaded inset



Optional five-piece drawer header
Flush inset



Optional profiled drawer header
Flush inset

Montico door style in Quarter Sawn Oak finished in Slate with Ebony glaze and Cottage Distressing
Standard slab drawer header | Flush inset
A11 | C11 | L11 | M11 | Q11 | RA11 | W12+25%



New!

REYNOLDS



Standard slab drawer header
Flush inset



Optional five-piece drawer header
Beaded inset

Reynolds door style in Maple finished in Natural
Optional five-piece drawer header | Flush inset
A11 | C11 | M11 | Q12 | RA11 | W12+25%

To best illustrate the profiles, each door is shown in Maple finished in Natural.
 The available wood types and price columns are listed below the photo, in the third row of information.



Rocheport door style in Quarter Sawn Oak
 finished in Toffee
 Standard slab drawer header | Flush inset
A11 | C11 | L11 | M11 | Q11 | RA11 | W12+25%

ROCHEPORT



Standard slab drawer header
 Flush inset



Optional five-piece drawer header
 Beaded inset



Rock Elm door style in Maple finished in
 Crystal Fog with Chocolate glaze
 Standard slab drawer header | Flush inset
A11 | C11 | L11 | M11 | Q11 | RA11 | W12+25%

ROCK ELM



Standard slab drawer header
 Beaded inset



Optional five-piece drawer header
 Flush inset



Optional profiled drawer header
 Flush inset

timeless craftsmanship
inset door styles



New!

RUTLAND



Standard slab drawer header
Beaded inset



Optional five-piece drawer header
Flush inset

Rutland door style in Maple finished in Natural
Standard slab drawer header | Flush inset
A12 | C12 | M12 | Q12 | RA12

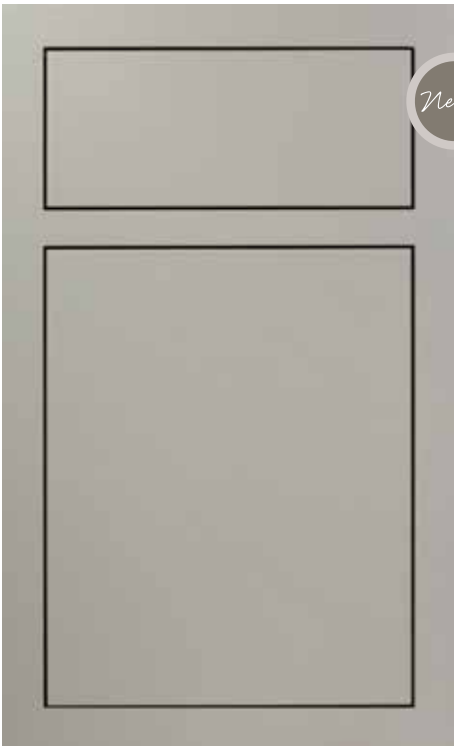

New!

TERRA

Terra door style in MDF finished in Creekstone
Standard slab drawer header | Flush inset
MDF 11

To best illustrate the profiles, each door is shown in Maple finished in Natural.
 The available wood types and price columns are listed below the photo, in the third row of information.



New!

VICTOR



Standard slab drawer header
Beaded inset



Optional five-piece drawer header
Flush inset

Victor door style in Maple finished in Natural
 Optional five-piece drawer header | Beaded inset
 A12 | C12 | M12 | Q12 | RA12

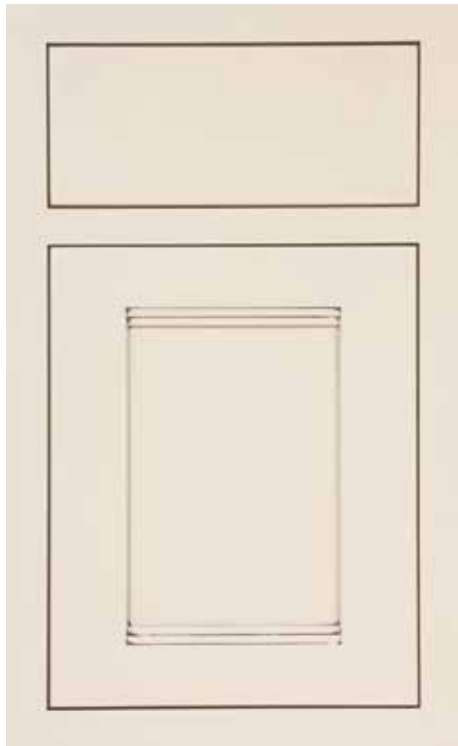

WINTERHAVEN



Standard slab drawer header
Beaded inset



Optional five-piece drawer header
Beaded inset

Winterhaven door style in Maple finished in
 Repose Grey with Ebony glaze
 Standard slab drawer header | Flush inset
 A11 | C11 | L11 | M11 | Q11 | RA11

timeless craftsmanship
inset door styles



Woodlawn door style in Cherry finished in Driftwood with Chocolate glaze
Optional profiled drawer header | Flush inset
A11 | C11 | L11 | M11 | Q11 | RA11

WOODLAWN



Standard slab drawer header
Beaded inset



Optional five-piece drawer header
Flush inset



Optional profiled drawer header
Flush inset



Xenon door style in Rustic Alder finished in Homestead Fog
Optional five-piece drawer header | Flush inset
A12 | C12 | L12 | M12 | Q12 | RA12

XENON



Standard slab drawer header
Beaded inset



Optional five-piece drawer header
Flush inset

CONSTRUCTION DETAILS

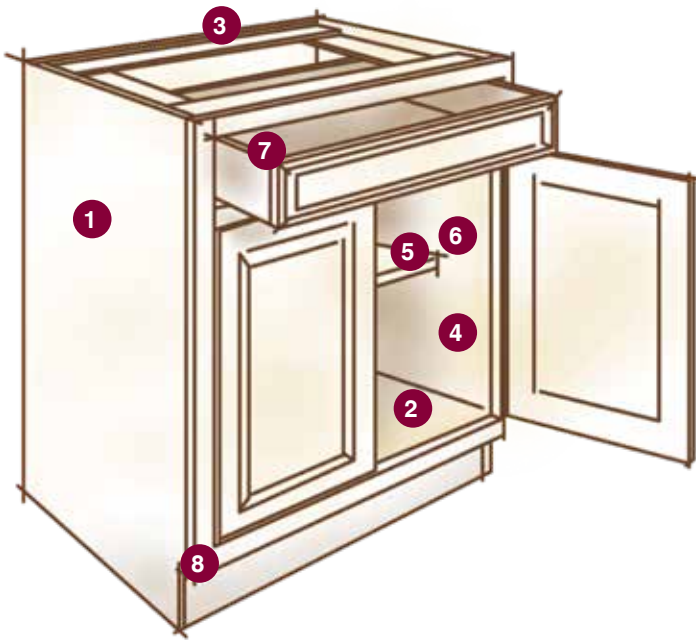

- | | |
|------------------------------|--|
| 1. End (side) Panel Material | 3/4" hardwood plywood veneer core—Unfinished |
| Option | 3/4" hardwood plywood veneer core—Finished |
| Option | 3/4" hardwood plywood veneer core—Flushed Furniture End |
| Option | 3/4" hardwood plywood veneer core—Flushed & Finished |
| 2. Top/Bottom Material | 1/2" hardwood plywood veneer core |
| 3. Back Panel Material | 1/2" hardwood plywood |
| Option | 3/8" beaded back |
| Option | 3/4" flush back |
| 4. Interior Finish | Natural birch melamine |
| Option | Stained matching veneer |
| Option | Natural maple veneer |
| 5. Shelf Material | 3/4" hardwood plywood |
| 6. Base Cabinet Shelf | Two-Thirds Depth |
| Option | Full Depth |
| 7. Drawers & Roll Trays | 5/8" Birch, Dovetail Joinery |
| Glides | Soft close, full extension, under-mount |
| Option | Walnut drawer boxes and roll trays |
| 8. Face Frame | Beaded or Flush |
| 9. Door Hinges | Concealed hinge with soft close, or full wrap finial hinge in five colors: Dark Oil Rubbed Bronze, Pewter, Matte Nickel, Black and Copper Bronze |

FACE FRAME OPTIONS

All inset door styles are available with a Beaded or Flush face frame.

BEADED INSET FACE FRAME

Openings of face frame feature a bead.

FLUSH INSET FACE FRAME

Openings of face frame are square.



FINIAL HINGE COLORS

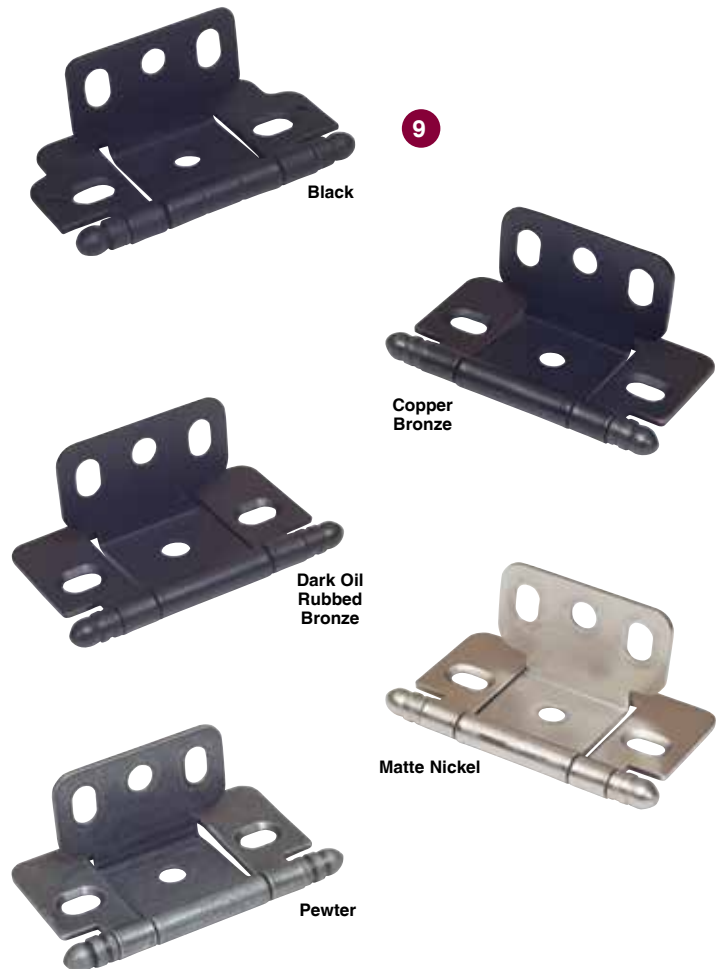

DRAWER HEADER OPTIONS

FIVE-PIECE DRAWER HEADER

Available on all inset door styles.



ROLLED PROFILED DRAWER HEADER

Available on the Allentown, Kingsberry, Laforest, Montico and Rock Elm inset door styles.



SCOOPED PROFILED DRAWER HEADER

Available on the Danburg, Merrimac and Woodlawn inset door styles.



FURNITURE PEGS

This option gives rustic character to doors and drawers. A 5/16" square wooden peg is driven into a 3/8" diameter drill hole. The gaps between the peg and the hole are visible and are not filled. Single pegs (illustrated below) and double pegs are available. Available on all inset door styles.



Laforest door style in Cherry finished in Nutmeg. Shown in beaded inset with optional five-piece drawer headers.



Laforest door style in Cherry finished in Harvest. Shown in beaded inset with optional profiled drawer headers.





Rock Elm inset door style in Maple finished in Dove. Island cabinets created with the Rock Elm inset door style in Maple finished in Blueberry. Shown in beaded inset with standard slab drawer headers.

Our complete collection of stain-based cabinet colors is shown below.

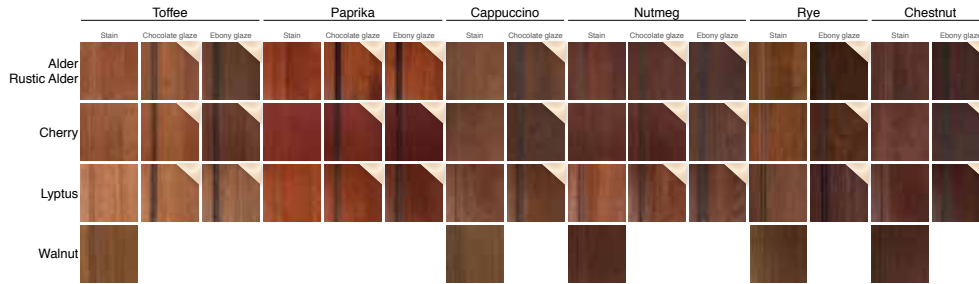
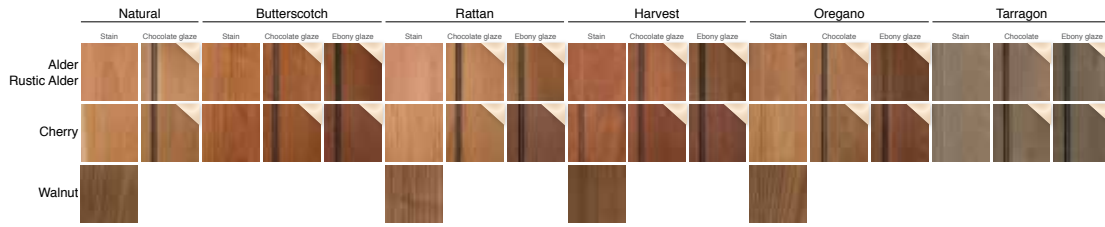

This icon indicates that the color can receive Old World Distressing illustrated on page 23.



New!

New!

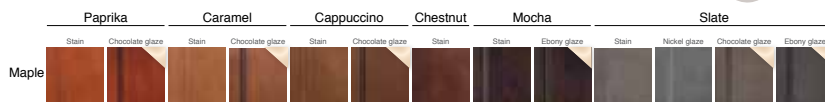
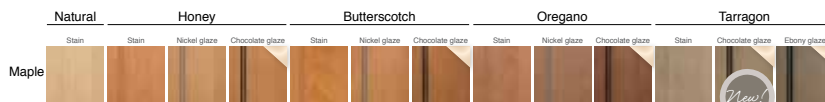

Our collection of Specialty Colors for Alder, Rustic Alder and Cherry is shown below.



New!

Find out more about Stains, Tinted Varnish and Glaze on page 38.

Our complete collection of Tinted Varnish cabinet colors is shown below.

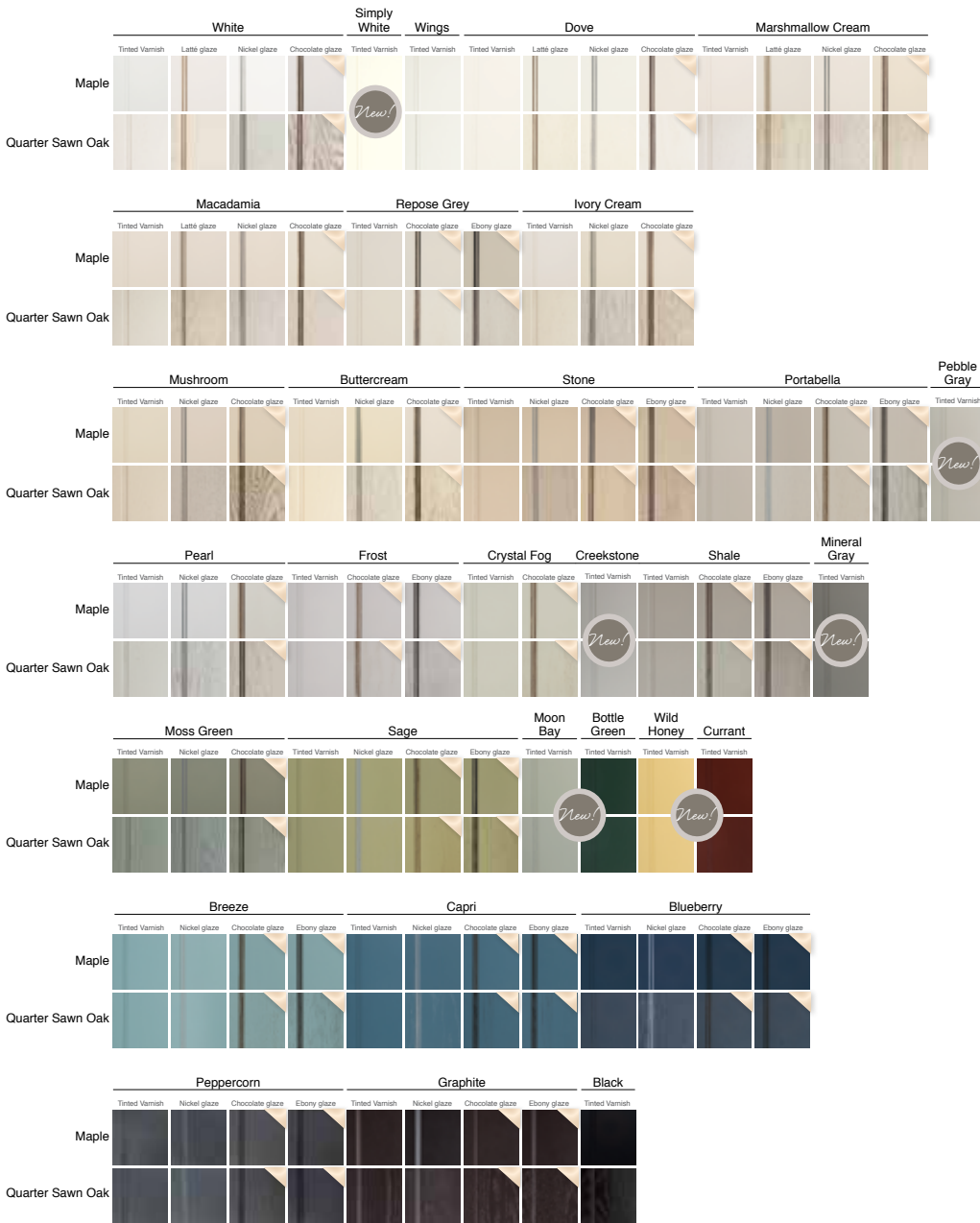

This icon indicates that the color can receive Old World Distressing illustrated on page 23.

Our complete collection of Specialty Colors for Maple and Quarter Sawn Oak is shown below.



SPECIALTY COLORS are cabinetry finishes that take your room to a whole new level. Artistic effects are added to popular colors to add character and in some cases, a vintage feel.

VILLA

A specialty color for Maple cabinetry

The Villa finish results in a look that suggests brush strokes along the face of the doors and drawers, and any other finished part of the cabinetry. The color and brush stroke technique will vary from door to door and will blend throughout the cabinetry. Villa is available on Maple door styles.

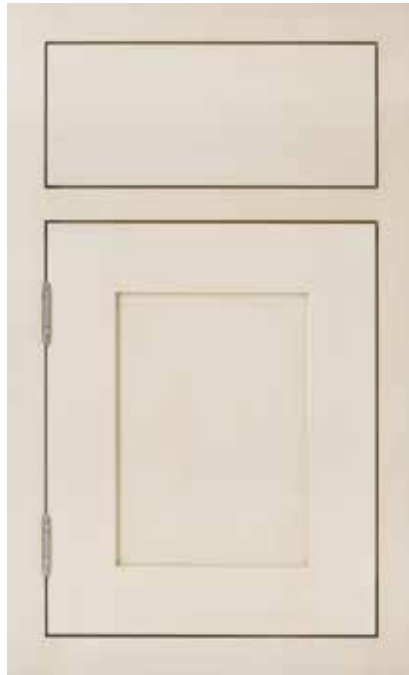

Fairhaven door style in Maple finished in Villa Ivory.



DeWitt door style in Maple finished in Villa Mushroom.

AMARETTO & BORDEAUX

Specialty colors for Maple cabinetry

Amaretto and Bordeaux are Black finishes with rounded corners, worn edges and light chain distressing. Additional worn areas on center panels and door frames expose golden butterscotch tones on the Amaretto finish and beautiful burgundy tones on the Bordeaux finish. Amaretto and Bordeaux are available on Maple door styles. Amaretto and Bordeaux can receive Old World Distressing, illustrated on page 27.



Lafontaine door style in Maple finished in Amaretto.



Lafontaine door style in Maple finished in Bordeaux.

LICORICE

A specialty color for Maple and Quarter Sawn Oak cabinetry

Licorice is a Black finish with rounded corners, worn edges and light chain distressing. Nickel glaze is applied to accent the door profiles. Licorice is available on Maple and Quarter Sawn Oak door styles.



Alexandria door style in Maple finished in Licorice.



Rock Elm door style in Quarter Sawn Oak finished in Licorice.

Specialty Colors

CHATEAUX

A specialty color for Cherry cabinetry

Chateaux is created by randomly applying several distressing techniques, softening all edges, padding the edges to create shadowing, and adding speckling to accentuate the distressing. Patina is accomplished with rounded corners, worn edges, knife cuts, worm holes, rasping, dips and light chain distressing that we hand apply to drawers, doors and throughout the cabinetry. A protective topcoat completes the look. The finish is oven cured for durability. Chateaux colors are shown below. Chateaux is available on Cherry door styles.



Alexandria door style in Cherry finished in Chateaux Brittany. Shown in beaded inset with standard slab drawer headers.

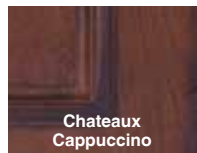

Chateaux Cappuccino

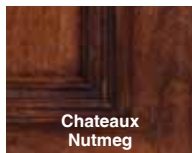

Chateaux Nutmeg

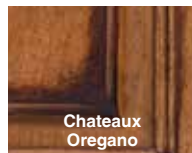

Chateaux Oregano

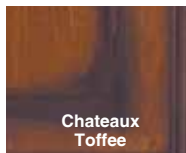

Chateaux Toffee

ANTIQUITY

A specialty color for Alder and Rustic Alder cabinetry

To create Antiquity, our artisans apply the Ebony glaze by hand and brush it. The resulting look echoes a time-worn patina. Antiquity is available on Alder and Rustic Alder door styles.

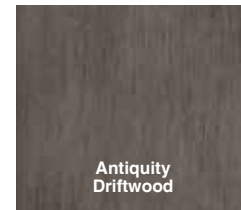

Antiquity Driftwood



Antiquity Fog

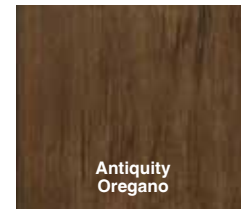

Antiquity Oregano



Antiquity Peppercorn

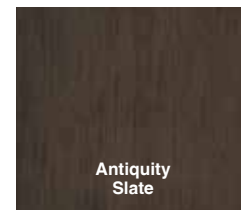

Antiquity Slate

HOMESTEAD

A specialty color for Alder and Rustic Alder cabinetry

Several distressing techniques are applied randomly and heavily. Distressing marks are rounded corners, worn edges, knife cuts, abundant worm holes, rasping, dips, light chain distressing and chiseling. They are applied to drawers, doors and throughout the cabinetry. A protective topcoat completes the look. The finish is oven cured for durability. Homestead is available on Alder and Rustic Alder door styles.



Homestead Blueberry



Xenon door style in Alder finished in Homestead Fog. Shown in flush inset with optional five-piece drawer headers.

Cottage Distressing

Cottage Distressing is a sweet, welcoming look created with rounded corners and worn edges. A third technique, light chain distressing, is optional. Glaze brings out the wood's unique texture, and a durable topcoat completes the process, protecting both the color and the marks.

Cottage Distressing is available on:

- Any Stain with Glaze combination. See page 22.
- Any Tinted Varnish with Glaze combination. See page 23.

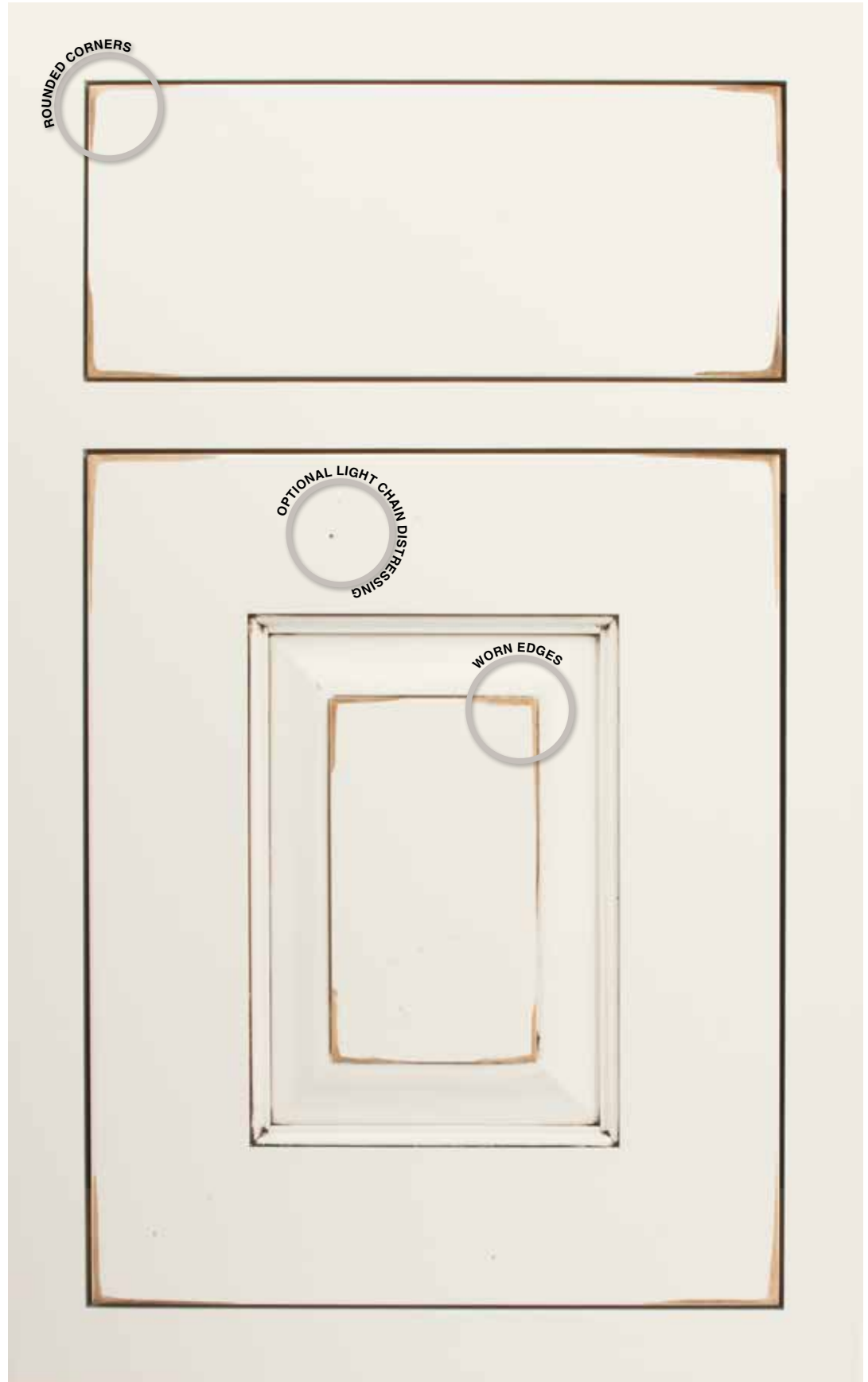

Kingsberry door style in Maple finished in Marshmallow Cream with Chocolate glaze and Cottage Distressing. Shown in flush inset with standard slab drawer header.

Old World Distressing

Old World Distressing blends your new cabinetry with today's popular distressed furniture pieces. Distressing techniques are randomly applied to the face of your cabinetry throughout the design. These techniques are:

1. rounded corners
2. rasping
3. dips
4. knife cuts
5. worm holes
6. worn edges
7. light chain distressing.



Look for this icon on pages 22-23 for colors that can receive Old World Distressing.

Danburg door style in Maple finished in Peppercorn with Chocolate glaze and Old World Distressing. Shown in flush inset with optional five-piece drawer header.

Distressing illustrated

StarMark Cabinetry uses several techniques to add character and appeal to cabinetry. They are illustrated on these two pages. All of our distressing marks are added by hand. There is no machine and there is no robot that can successfully duplicate what the eyes and hands of an artisan achieve through personal handling of the cabinetry.



CHISELING

Chiseling is used to create Homestead.



DIPS

Dips are used to create Chateaux and Homestead and they are included in Old World Distressing.



ROUNDED CORNERS

Rounded Corners are used to create Amaretto, Bordeaux, Chateaux, Homestead and Licorice. They are included in Cottage Distressing and Old World Distressing.

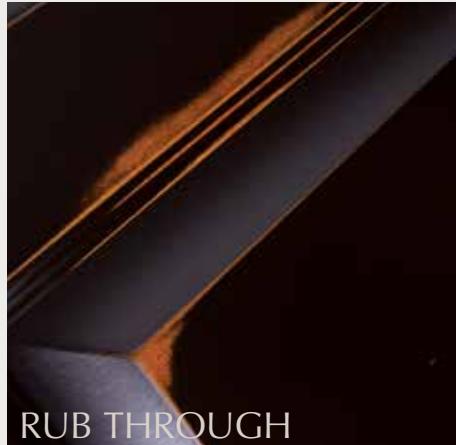

RUB THROUGH

Rub Through is used to create Amaretto and Bordeaux.



SPECKLING,
DARK BROWN

Speckling is used to create Chateaux.



Allentown door style in Maple finished in Bordeaux.



KNIFE CUTS

Knife Cuts are used to create Chateaux and Homestead and they are included in Old World Distressing.



PADDING

Padding is used to create Chateaux.



RASPING

Rasping is used to create Chateaux and Homestead and it is included in Old World Distressing.

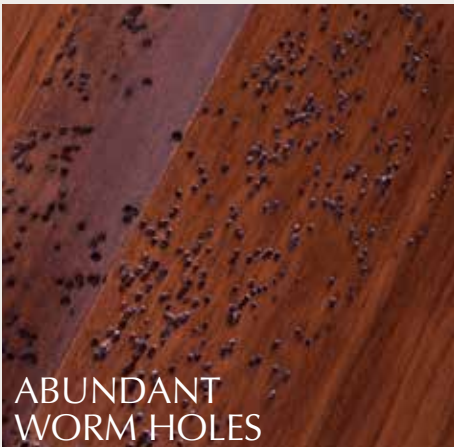

ABUNDANT WORM HOLES

Abundant Worm Holes are used to create Homestead.

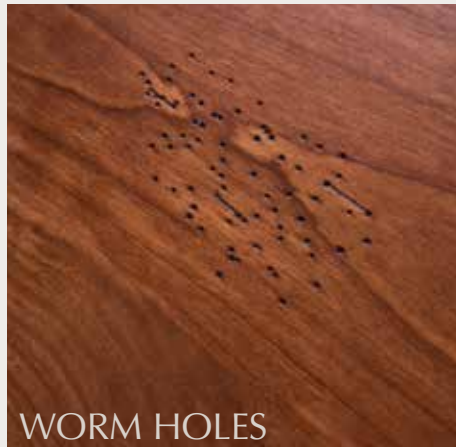

WORM HOLES

Worm Holes are used to create Chateaux and are included in Old World Distressing.



WORN EDGES

Worn Edges are used to create Amaretto, Bordeaux, Chateaux, Homestead and Licorice. They are included in Cottage Distressing and Old World Distressing.

A Light Touch



SPATTERING

Spattering is a dark stain, hand applied randomly to the cabinetry.

- Spattering on stain with glaze combinations is free of charge.
- Spattering on an unglazed stain is available on all species at an upcharge.

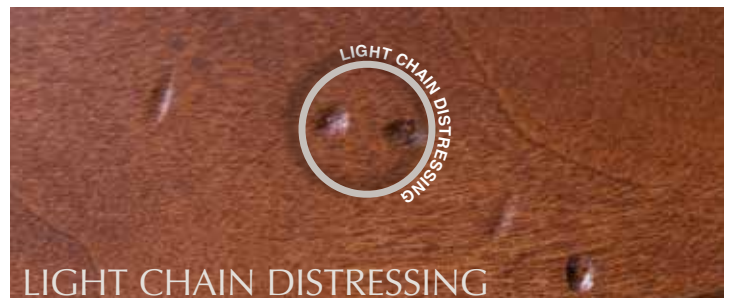

LIGHT CHAIN DISTRESSING

Light Chain Distressing is used to create Amaretto, Bordeaux, Chateaux, Homestead and Licorice. It is included in Cottage Distressing and Old World Distressing.

- Light chain distressing on Tinted Varnish with glaze combinations is free of charge.

Light chain distressing is available at an upcharge on:

- all stains on any wood type
- all stain with glaze combinations on any wood type
- all Tinted Varnish on Maple, Oak or Quarter Sawn Oak





Alexandria door style in Maple finished in Marshmallow Cream and the Alexandria door style in Cherry finished in Brittany. Shown in flush inset with standard slab drawer headers.



mullion doors

This hutch features mullion doors in the Heirloom pattern. The insert is glass in the Baroque pattern. The kitchen was created with the Alexandria door style in Cherry finished in Brittany. Shown in flush inset.

dress up your doors

mullion door patterns

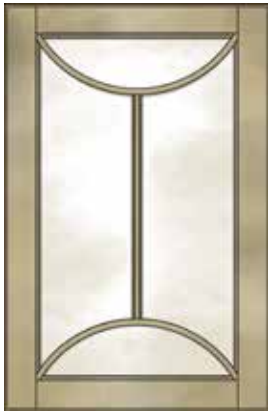

ENLIGHTEN

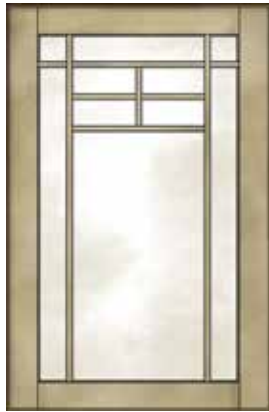

BUNGALOW

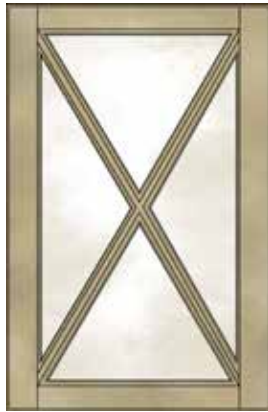

CROSSING



FOUR LITE MULLION

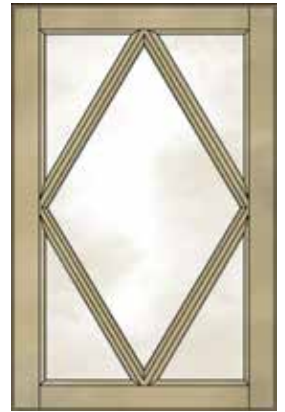

DIAMOND

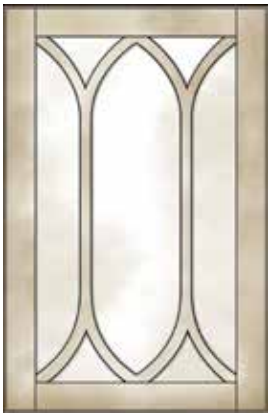

HEIRLOOM



MANOR



MISSION II



MISSION III



PLAINS

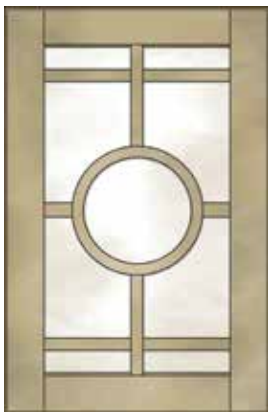

PORTAL

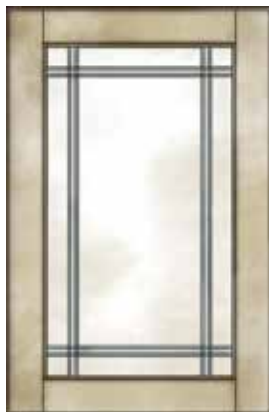

PRAIRIE MULLION

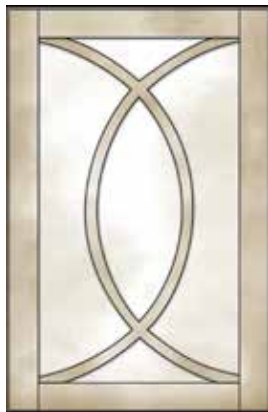

RADIUS



SIX LITE MULLION



insert for SINGLE PANEL DOOR

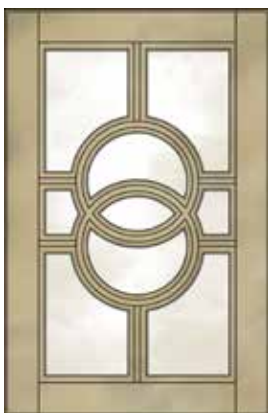

VENNICIA



The Thornton doors, insert door and mullion doors on this page can receive inserts. Inserts are shown on page 35.



THORNTON ACCENT



Alexandria door style in Maple finished in Macadamia and the Alexandria door style in Cherry finished in Brittany. Shown in flush inset with standard slab drawer headers. The hutch features mullion doors in the Heirloom pattern. The insert is glass in the Baroque pattern.

add some sparkle

door and drawer inserts

LEADED GLASS INSERTS



Radius*

Mullion*

Craftsman*

Lace*

ETCHED GLASS INSERTS



Grapevine

Ivy

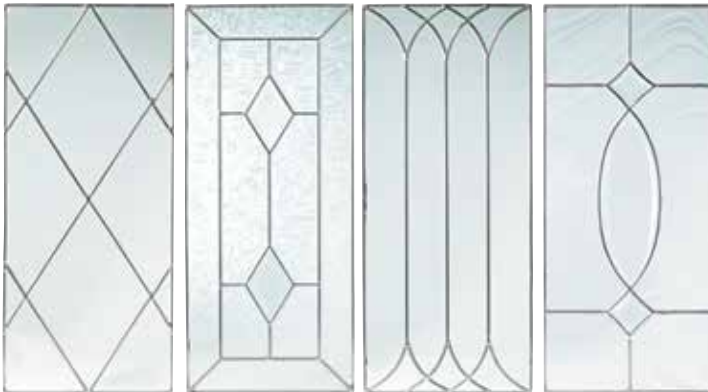

Lattice*

Classic*

Heirloom*

Unity*

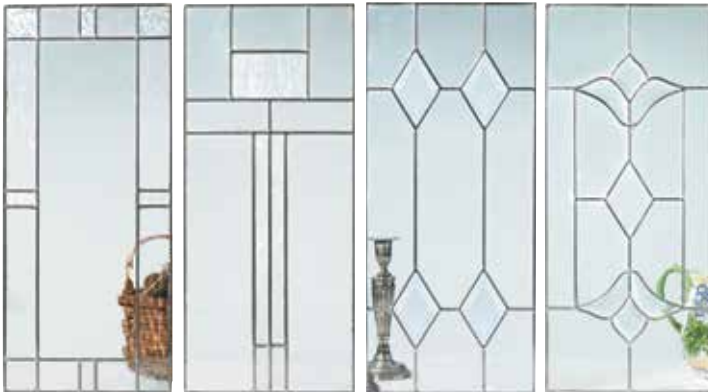

Prairie*

Mission*

Diamonds*

Garden*



This kitchen was accented with Thornton accent doors. The inserts are glass in the KoKo Seedy pattern. The kitchen was created with the Fairhaven door style in Cherry finished in Toffee.

PATTERNED GLASS INSERTS



Artique

Baroque

Koko Seedy

1/8 Reeded

1/2 Reeded

BASIC GLASS



Water

Glue Chip

Cotswold

Clear Bevel

Clear

* Patterned glass is available only as shown. Patterns are shown with lead caming. Brass caming is available on some patterns.

TINTED GLASS INSERTS



Light Amber

Dark Amber

TEMPERED GLASS INSERTS



Clear

Listral D

Satin

wood types

Alder is a softer wood with a fine straight grain and even texture. Color is light brown with yellow or reddish tinge, with little difference between heartwood and sapwood. Alder does not evolve in color or darken when exposed to light or heat as other woods do, and takes stains and finishes well. More than some of the other woods, care must be taken to avoid damage due to its softer nature. Some small tight knots can be found with standard Alder.

Rustic Alder refers to the Rustic version of this wood type. Rustic Alder is characterized by knots, burls and mineral streaks found on center panels, stiles and rails of the door, and on the drawer headers, which could impact hardware placement. Knots will be sound and will be closed, but certain angles could show light through the knots. Glazing Rustic Alder will enhance these unique characteristics.

Cherry displays a distinctive grain pattern and warm color. The color ranges from nearly white to dark reddish brown. Dark pockets, pin knots, and random streaks are common. More than most woods, Cherry will darken when exposed to light, especially in light stains. The more sun Cherry receives, the faster it will darken. This will be most evident in new wood and will slow as it ages.

Lyptus is a hard, fine-grain hardwood with a rich, warm tone. Lyptus comes from fast-growing eucalyptus trees that are ready to be harvested within 14 to 16 years of planting. These trees are grown on non-tropical, certified plantations. Color variations can be extreme, but they are minimized when you choose a darker stain. More than most woods, Lyptus mellows and darkens with exposure to light. When Lyptus is stained in a dark color, it looks very much like mahogany.

Maple is a versatile hardwood with a fine, smooth grain. It varies in color from nearly white to a slightly reddish brown. Mineral or sugar streaks occur naturally in Maple and can vary from piece to piece. Variations will be more noticeable in lighter stains.

Quarter Sawn Oak is milled at an angle of 60 to 90 degrees from the grain, allowing rays and flecks to become visible, giving the wood a unique, often vintage, character and dimension.

Walnut is a strong, stable American hardwood known for wide color variation. It ranges in color from creamy white to a medium purplish brown. Walnut cabinetry will have both flowing grain and straight grain. This combination is a treasured characteristic of Walnut, and is showcased when Walnut is finished in Natural. However, Walnut takes all available stains well. Walnut is a favorite choice for furniture and furniture grade cabinetry, such as StarMark Cabinetry.



standard
ALDER

Shown here in Natural.



rustic
ALDER

Shown here in Natural.



standard
CHERRY

Shown here in Natural.



LYPTUS

Shown here in Toffee.



MAPLE

Shown here in Natural.



QUARTER SAWN OAK

Shown here in Natural.



WALNUT

Shown here in Natural.





The kitchen was created with the Montico door style in Maple finished in White and in Graphite. Shown in beaded inset with optional five-piece drawer headers. Featuring mullion doors in the Heirloom pattern. The mirror inserts were supplied by the homeowner.

STARMARK CABINETRY IS ENVIRONMENTALLY RESPONSIBLE.

StarMark Cabinetry is a certified brand in the Kitchen Cabinet Manufacturers Association (KCMA) Environmental Stewardship Program. The program recognizes companies that demonstrate an ongoing commitment to sustainability including the use of environmentally responsible materials in cabinet products and minimized environmental impacts realized through recycling wastes and using low emission coatings. By achieving this certification, StarMark Cabinetry is going beyond minimum requirements and demonstrates leadership in growing a sustainable company.



StarMark Cabinetry is CARB II compliant and ESP certified. Kitchen Cabinet Manufacturers Association Environmental Stewardship Program. All products impact the environment. For ESP program criteria, visit kcma.org.

SPECIALTY COLORS

Use this chart to review the characteristics that are included with the color you selected.	SPECIALTY COLORS						
	Amaretto	Antiquity	Bordeaux	Chateaux	Homestead	Licorice	Villa
Brush stroke							•
Chiseling					•		
Dips				•	•		
Knife cuts				•	•		
Light chain distressing	•		•	•	•	•	
Padding				•			
Rasping				•	•		
Rounded corners	•		•	•	•	•	
Rub through on flat surfaces	•		•				
Spattering							
Speckling				•			
Wire brushing							
Worm holes				•			
Abundant Worm holes					•		
Worn edges on center panel	•		•	•	•	•	

Specialty Colors have characteristics that cannot be captured on a color chip, so color chips are not available in Amaretto, Antiquity, Bordeaux, Chateaux, Homestead, Licorice and Villa. Request a door sample to view these unique, beautiful colors.

Specialty Colors are cabinetry finishes that take your room to a whole new level. Artistic effects are added to popular colors to add character and in some cases, a vintage feel.



STAIN

A stain is a basic yet substantial finish that adds color to wood while revealing the beauty of the grain. The wood type affects the color of the stain, so the same stain will look different on each wood type. In some cases, the difference is dramatic. For the richest, most consistent color coverage, we apply the stain and then hand rub it into the wood. There are no machine shortcuts: elbow grease is the only way to coax the luster from stained wood.

TINTED VARNISH

The best way to describe Tinted Varnish is to say it gives cabinetry a paint-like finish. However, our Tinted Varnish is much more durable than paint. Throughout the country, this type of finish is also called "enamel" or "opaque". Tinted Varnish is available on Maple and Quarter Sawn Oak cabinetry, and each wood yields a different look. The grain of Maple wood is concealed by Tinted Varnish and the grain of Quarter Sawn Oak shows through Tinted Varnish.

GLAZE

StarMark Cabinetry has four glaze colors: Chocolate, Ebony, Latté and Nickel. Glazes are available to go over both stains and Tinted Varnishes. We apply the glaze by hand and then wipe it off by hand. When our craftsman wipes off the glaze, he or she can best use the glaze to define the details in that particular kitchen. The profiles on a door and drawer, and other details on cabinetry, such as corbels, rosettes or shells, are stunning when glazed. We glaze every part of your cabinetry by hand—doors, drawers, moulding and panels.

OPTIONS FOR STANDARD PALETTE COLORS

The standard palettes for Stain and Tinted Varnish are shown on pages 22–23.

Is your color a Stain?

- Do you want to add spattering?
- Do you want to add light chain distressing?

Is your color a Stain with Glaze?

- Do you want to add spattering?
- Do you want to add light chain distressing?

Is your color a Stain with Glaze and Cottage Distressing?

- Do you want to add spattering?
- Do you want to add light chain distressing?

Is your color a Tinted Varnish?

- Do you want to add light chain distressing?

Is your color a Tinted Varnish with Glaze?

- Do you want to add light chain distressing?

Is your color a Tinted Varnish with Glaze and Cottage Distressing?

- Do you want to add light chain distressing?



ARTISAN EFFECTS

Artisan Effects are illustrated on pages 24–25.

ARTISAN EFFECTS			
Use this chart to review the characteristics that are included in the distressing package that you selected.	Cottage with light chain distressing	Cottage without light chain distressing	Old World Distressing
	Brush stroke (as seen in Villa)		
Chiseling (as seen in Homestead)			
Dips			•
Knife cuts			•
Light chain distressing	•		•
Padding (as seen in Chateaux)			
Rasping			•
Rounded corners	•	•	•
Rub through on flat surfaces			
Spattering			
Speckling (with dark brown, as seen in Chateaux)			
Worm holes			•
Worn edges on center panel	•	•	•

CUSTOM COLORS

Talk to your StarMark Cabinetry dealer about the additional costs and delivery times for a custom color.

Use this chart to review the characteristics you can add to your custom color.	CUSTOM COLORS			
	Custom Stain	Custom Stain with Glaze	Custom Tinted Varnish	Custom Tinted Varnish with Glaze
Artisan Effects				
Cottage with light chain distressing	•	•	•	•
Cottage without light chain distressing	•	•	•	•
Old World Distressing	•	•	•	•
Distressing techniques				
Brush stroke (as seen in Villa)			•	•
Chiseling (as seen in Homestead)	•	•	•	•
Dips	•	•	•	•
Knife cuts	•	•	•	•
Light chain distressing	•	•	•	•
Padding (as seen in Chateaux)	•	•		
Rasping	•	•	•	•
Rounded corners	•	•	•	•
Rub through on flat surfaces	•	•	•	•
Spattering	•	•	•	•
Speckling (with dark brown, as seen in Chateaux)	•	•	•	•
Worm Holes	•	•	•	•
Worn edges on center panel	•	•	•	•



BUY WITH CONFIDENCE

StarMark Cabinetry's construction, materials and all finishes are covered by a Limited Lifetime Warranty.

CONSTRUCTION CONSIDERATIONS



Inset cabinetry has doors that are precisely “set into” the cabinet’s face frame. We manufacture inset cabinetry with tight reveals and take great care to create square, true cabinets. When adding inset cabinetry to your home, consider:

1. Quality installation is a must. If cabinets are not installed properly, doors may appear warped even though they are not. Every homeowner should expect their walls and floors to have variations; a well-qualified installer can properly shim inset cabinetry so it does not become out of square.
2. Homeowners should be prepared to adjust their doors seasonally as temperatures change.
3. Wall, utility wall and wall base inset cabinets are 12" deep. The standard inside storage dimension is 10¾". Unless the cabinet is modified to a greater depth, the cabinet will not accommodate oversized plates or dinnerware.



STARMARK® C A B I N E T R Y

600 East 48th Street North • Sioux Falls, SD 57104 • www.starmarkcabinetry.com
This brochure is item #1450 and is called the "Inset Cabinetry" brochure.

© 2020 StarMark Cabinetry

-  www.pinterest.com/starmarkcabinet/
-  www.youtube.com/user/starmarkcabinet
-  www.houzz.com/pro/starmarkcabinetry/starmark-cabinetry
-  www.instagram.com/starmarkcabinetry/
-  Before and after transformations posted on www.facebook.com/starmarkcabinetry



American Craftsmanship
Manufactured in Sioux Falls, South Dakota from domestic and global components.



StarMark Cabinetry is CARB II compliant and ESP certified.
Kitchen Cabinet Manufacturers Association Environmental Stewardship Program
All products impact the environment.
For ESP program criteria, visit kcma.org.



StarMark Cabinetry is a Norcraft Companies brand. Norcraft Companies is part of the MasterBrand Cabinets Family.



DESIGN CREDITS

FRONT AND BACK COVER, PAGE 38
This kitchen was designed by Chad Smith, owner of Kitchensmith Fine Cabinetry & Design, a StarMark Cabinetry dealer in Natick, Massachusetts. Photography by Mary Prince Photography.

PAGES 20-21 This kitchen cabinetry was designed by Maureen Madigan, a designer on staff at Kitchen Intuitions, a StarMark Cabinetry dealer in Chatham, New Jersey. The builder for this project is KraftMaster Renovations in Chatham, New Jersey. Photography by Laura Moss Photography.

PAGE 37 This kitchen was designed by Christy Dunlap, a designer on staff at Jennings Builders Supply in Fletcher, North Carolina. Photography by Meechan Architectural Photography.

SHOWN HERE AND ON COVER Rocheport door style in Maple finished in Marshmallow Cream. Shown in beaded inset with optional five-piece drawer headers.

Accuracy of all reprinted color is subject to printing limitations.

Dealers, this brochure includes these recent product introductions: Bottle Green, Carbon, Creekstone, Currant, Mineral Gray, Moon Bay, Pebble Gray, Tarragon on Maple, Villa Marshmallow Nickel, Villa Breeze Ebony, Villa Capri Ebony and Wild Honey finishes; and the Addison, Annabella, Ballinger, Cambridge, Claymont, Evaro, Liberty, Reynolds, Rutland, Terra and Victor door styles. This brochure was printed in June 2020.