

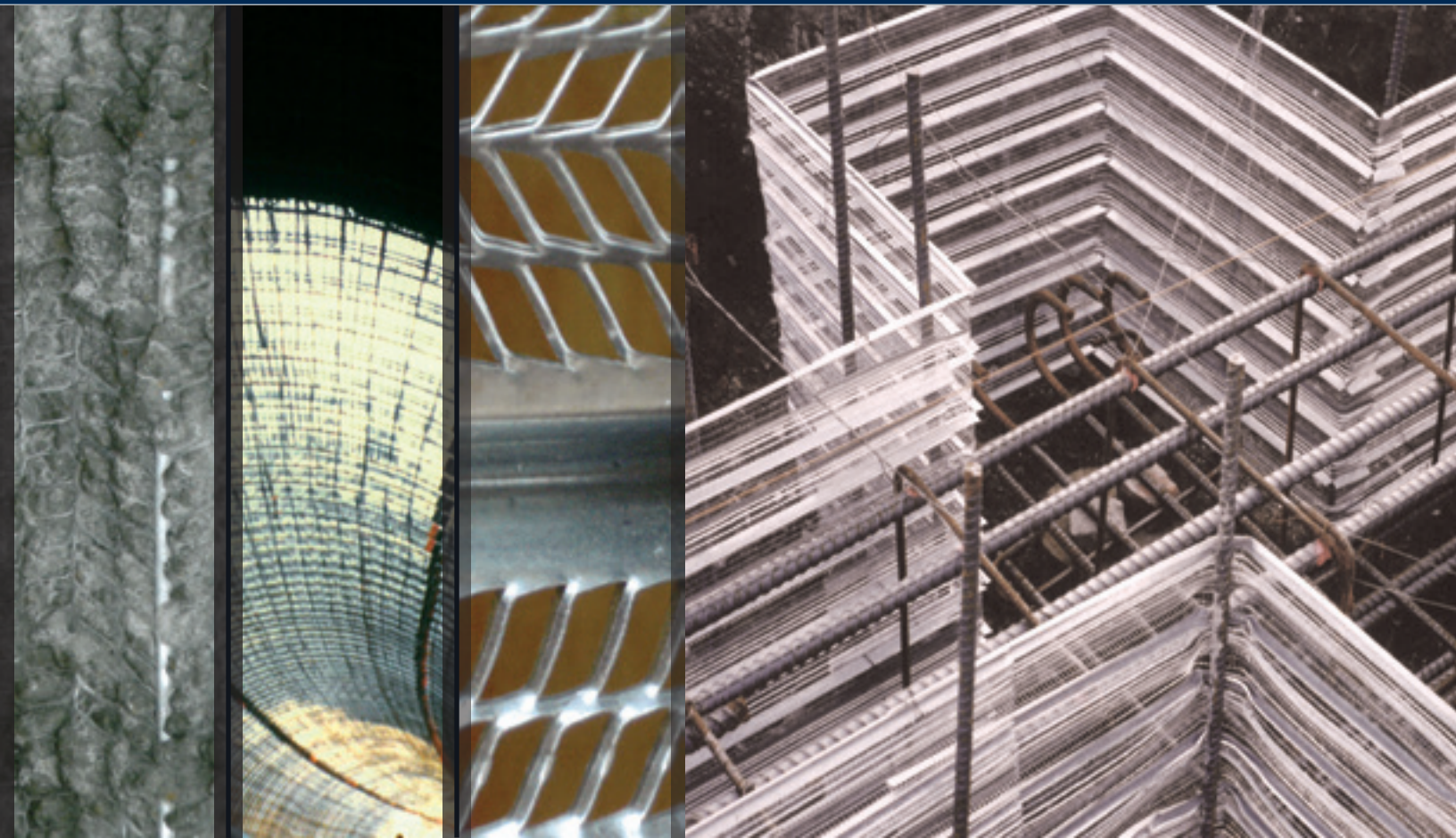

A GIBRALTAR INDUSTRIES COMPANY 

STAY-FORM®



TRANSFORMING MATERIALS

into products that make a better world

TABLE OF CONTENTS

Product Information	Page 1
Blindside Walls	Pages 2-4
Bulkheads.....	Page 5
Pile Caps	Page 6
Grade Beams	Page 7
Ductbanks	Page 8
Bridges.....	Page 9
Shotcrete.....	Page 10
Test Data	Pages 11-12
Installation Notes	Page 13



STAYS IN PLACE
35% LABOR SAVINGS
NO STRIPPING OF FORMS

QUALITY PRODUCTS – AROUND THE GLOBE



A GIBRALTAR INDUSTRIES COMPANY 

ALABAMA METAL INDUSTRIES CORPORATION

3245 Fayette Avenue • Birmingham, AL 35208

Phone (205) 787-2611 • (800) 366-2642 • Fax (205) 786-6527

www.amicoglobal.com

PRODUCT INFORMATION

Stay-Form® is produced from hot-dipped galvanized sheet steel per ASTM-A653

Weight	11.9 lbs. per sheet
V-Ribs	3/4" deep and 3 7/8" on center
Sheet size	27" wide x 96" long* (18 sq. ft. per sheet)
Pallet	250 sheets per pallet (4500 sq. ft.)

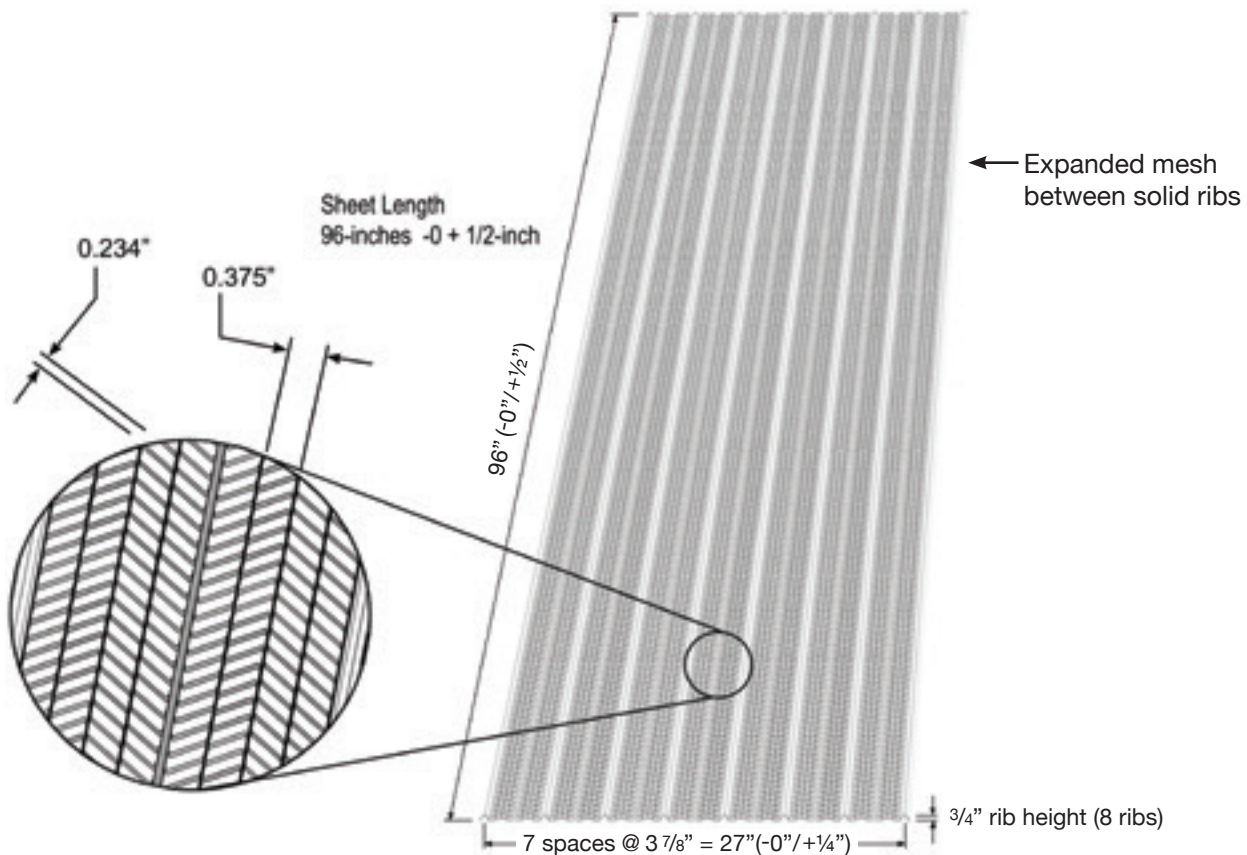

Features & Benefits

- Reduced labor cost—no stripping costs (bracing only)
- No scabbling in preparation for the next pour
- No cost for the disposal of plywood or transporting conventional forms for future use
- Lightweight sheets are easy to work with (install, cut, bend, etc.)
- Easy rebar and conduit penetrations
- Visual inspection of concrete pour and consolidation
- Retains surrounding soil while forming below grade structures
- Permits water to run out of formwork during concrete pour

Applications

- Blindside Walls
- Pile Caps & Grade Beams
- Bulkheads
- Keyways
- Ductbanks
- Shotcrete Backstop

BLINDSIDE WALLS



When a contractor has to form a concrete wall within a few inches of an existing structure, Stay-Form is an excellent product. By utilizing Stay-Form with rebar studs, hook ties, and a modular form system, a one-sided form or blindside wall can be constructed. If you do not have the luxury or room to strip formwork, Stay-Form is the right product for the job.

- The V ribs run perpendicular to the vertical rebar studs which gives the Stay-Form the rigidity to withstand the concrete pressures (*see detail*).
- Stay-Form can be slit with tin snips or hand-held grinder to accommodate the rebar hook tie (*see detail*).
- Stay-Form is commonly used for concrete pour rates of 4 to 7 feet per hour.*

To see more examples of blindside wall applications, visit www.amicoglobal.com and click on *Project Photos*.

*Reference *Guidelines for Loading & Bracing Spacings* chart on page 12.

BLINDSIDE WALLS

Blindside Wall Form Using Stay-Form

NOTES:

1. Wire tie Stay-Form to rebar every other rib.
2. The Stay-Form ribs go into the pour.
3. Lap Stay-Form sheets over a rebar support.
4. Vertical lap (2 ribs minimum).
5. Recommended pour rate is 4' to 7' per hour.*
6. Do not vibrate previous lift by more than 6".
7. Where sheets lap, use 16-gauge tie wire or sheet metal screws with a minimum 3/8" head.
8. Stay-Form is compatible with self-consolidating concrete.

*Horizontal lap 4-8" minimum (see stud spacing chart on page 12)

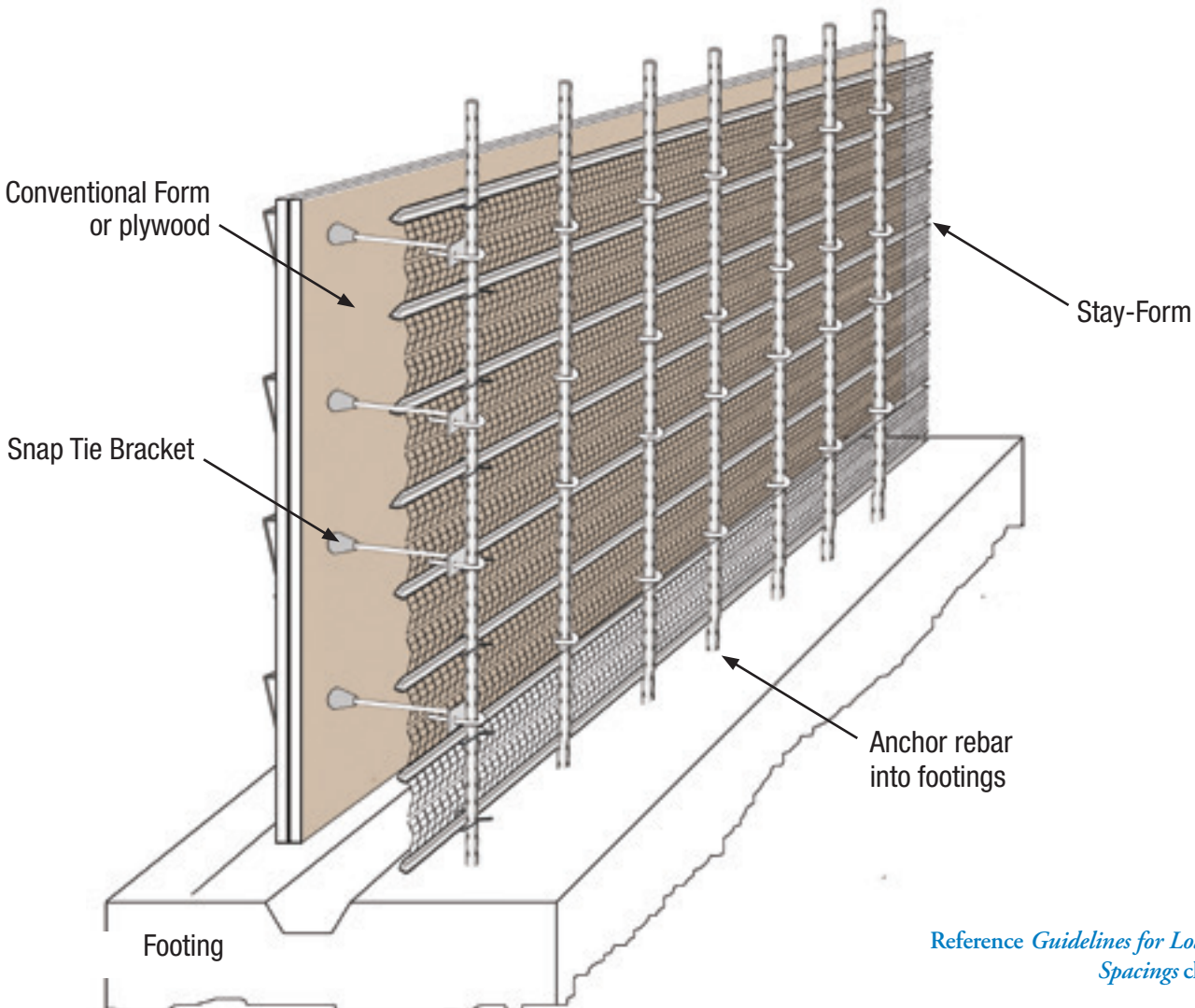

Reference *Guidelines for Loading & Bracing Spacings* chart on page 12.

Applications Using Stay-Form and AMICO Blindsided Wall Ties

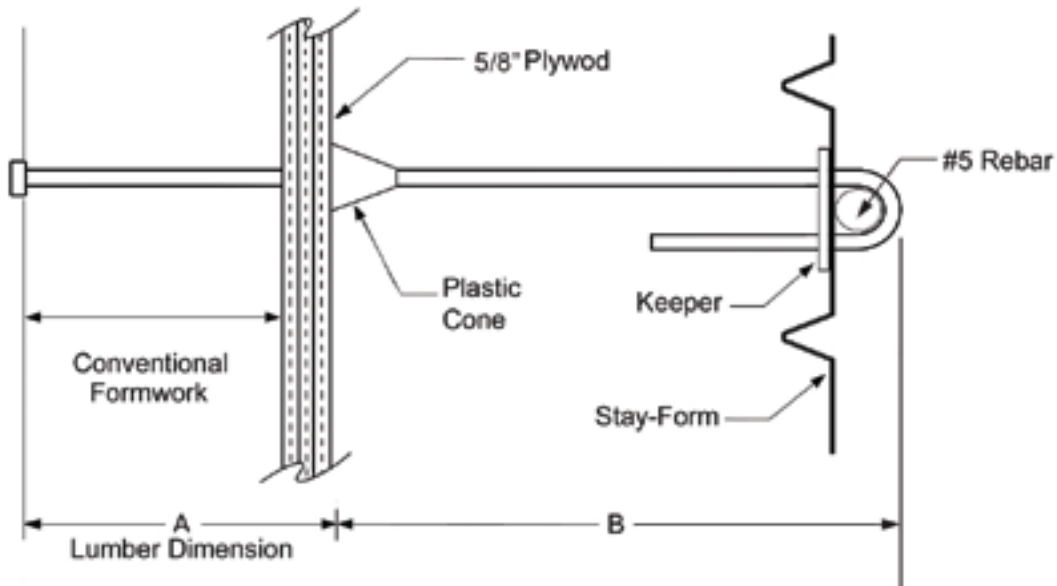

Cut a slit in the Stay-Form using metal snips. After hook tie has been inserted through the slit in the Stay-Form engage the rebar stud. Slide keeper into place. Ties are available up to 48" long.

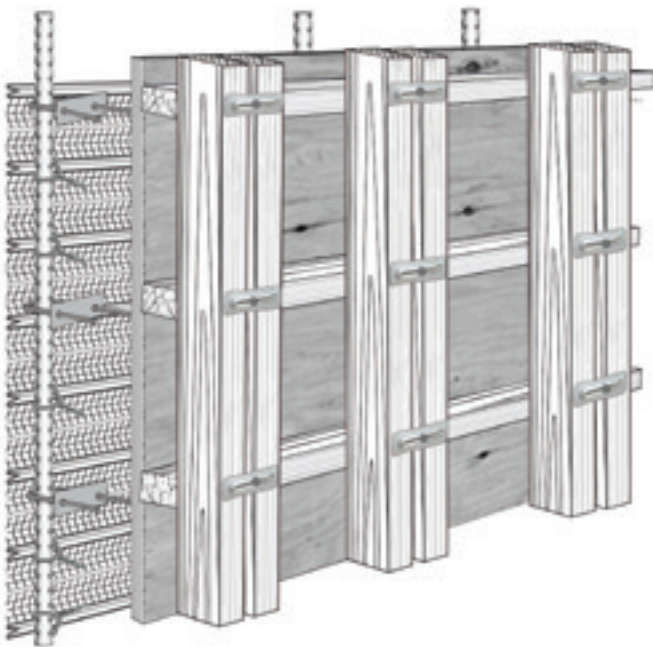

Double Waler

The lumber dimension "A" for a double waler is 8¼-inches to accommodate the general thickness of 5/8 or 3/4-in plywood, two widths of 2x4's and 1/2-in for the snap tie bracket.

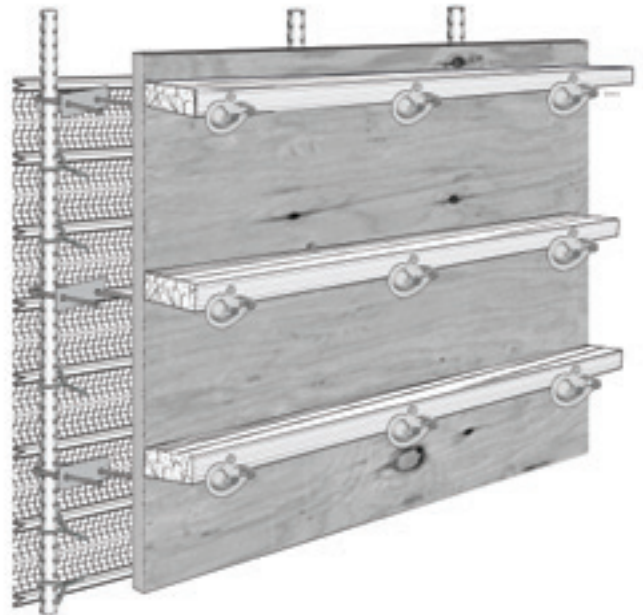

Single Waler

The lumber dimension "A" for a single waler is 4-11/16 inches to accommodate the general thickness of 5/8 or 3/4-inch plywood, one width of 2x4 and 1/2-in for the snap tie bracket.

BULKHEADS

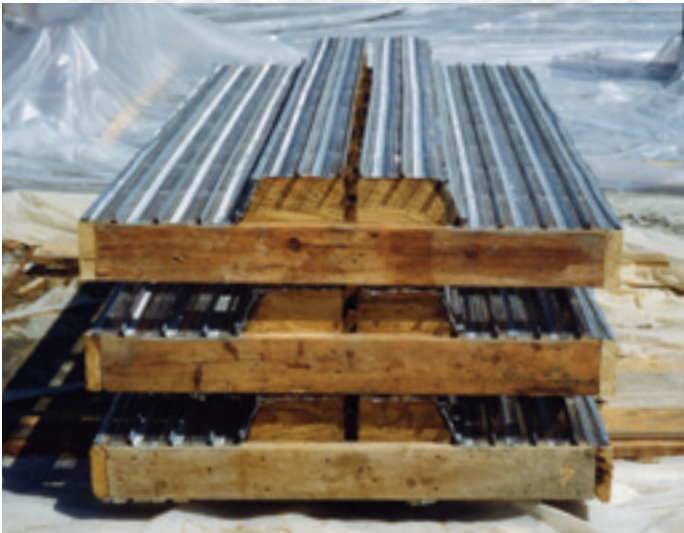

Stay-Form is an excellent product for forming bulkheads because it does not have to be stripped out after the concrete pour. (Plywood and modular forms have to be stripped.) There is also no scabbling required in order to prepare the surface for the next pour.

- Rebar or metal fabricated bracings are left in place – no stripping is required.
- The sheets are lightweight and can easily be bent to form a keyway.
- Stay-Form can be cut in order to accommodate any rebar or conduit penetrations.
- Visual inspection of the concrete consolidation is also accomplished due to the openings in the mesh.

Test reports prove that when forming bulkheads, Stay-Form provides 21% greater shear bond strength to concrete than does plywood.

To see more examples of bulkhead applications, visit www.amicoglobal.com and click on *Project Photos*.

PILE CAPS

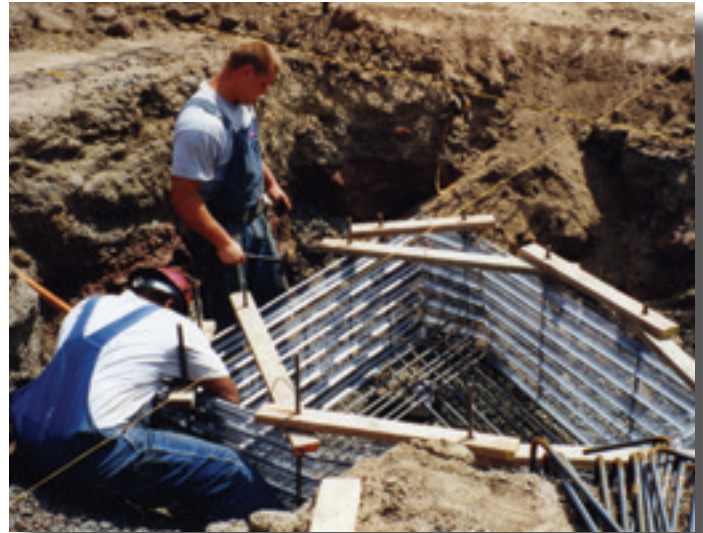

When forming below grade structures like a pile cap, Stay-Form can save a considerable amount of time and labor. You have no labor for stripping forms. If rebar or metal is used for bracing, it stays in place. (Wood bracing has to be removed.) Some contractors backfill around the Stay-Form prior to the pour therefore they minimize bracing and prevent a blowout of the form.

- Contractors can cut the V ribs in order to bend the sheets to any shape.
- During the concrete pour any water in the form will run out of the Stay-Form as it is displaced by the concrete (no pumping it out).
- Concrete finish is not a concern since backfill or a slab-on-grade concrete pour is a typical design with a pile cap foundation.

To see more examples of pile cap applications, visit www.amicoglobal.com and click on *Project Photos*.

GRADE BEAMS



Grade beams are easily formed using Stay-Form and rebar or lumber as bracing. Some contractors prefer to backfill 75 to 90 percent up the grade beam prior to the concrete pour in order to minimize the required bracing. Backfilling acts as the bracing which will stop the formwork from spreading during the pour.

- Attaching with tie wire around the Stay-Form ribs and rebar or lumber makes installation easy.
- Since the Stay-Form is not stripped, the excavation required is less than what would be needed using conventional formwork.
- Some contractors use Stay-Form to hold the surrounding soil from falling in on the grade beam excavation and reinforcing steel.

To see more examples of grade beam applications, visit www.amicoglobal.com and click on *Project Photos*.

DUCTBANKS



Electrical contractors find it easier to form ductbanks with Stay-Form than with plywood or conventional forming systems. The learning curve to train personnel how to install Stay-Form is quick, and the labor savings are significant due to the fact that form stripping is not necessary.

- Attaching Stay-Form to rebar supports is easily accomplished with tie wire.
- Attaching a 2x4 (from rebar to rebar) across the top of the ductbank prevents the formwork from spreading during the pour.
- Visual inspection of the concrete consolidation is also an advantage when using Stay-Form in order to avoid honeycombing.

To see more examples of ductbank applications, visit www.amicoglobal.com and click on *Project Photos*.

BRIDGES

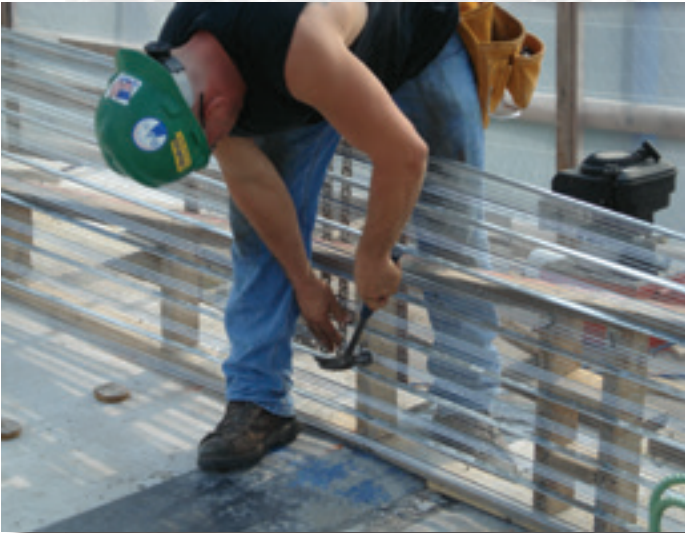

Contractors frequently use Stay-Form on bridge projects to form footings, edge forms and bulkheads. When building a cast-in-place segmental box girder bridge, forming the bulkheads has significant labor savings because the bulkhead does not have to be stripped.

- Test reports prove that when forming a bulkhead, Stay-Form provides 21% greater shear bond strength to concrete than does plywood.
- Unlike plywood-formed bulkheads, Stay-Form bulkheads do not require scabbling of the concrete. This means additional labor savings.

To see more examples of bridge applications, visit www.amicoglobal.com and click on *Project Photos*.



SHOTCRETE

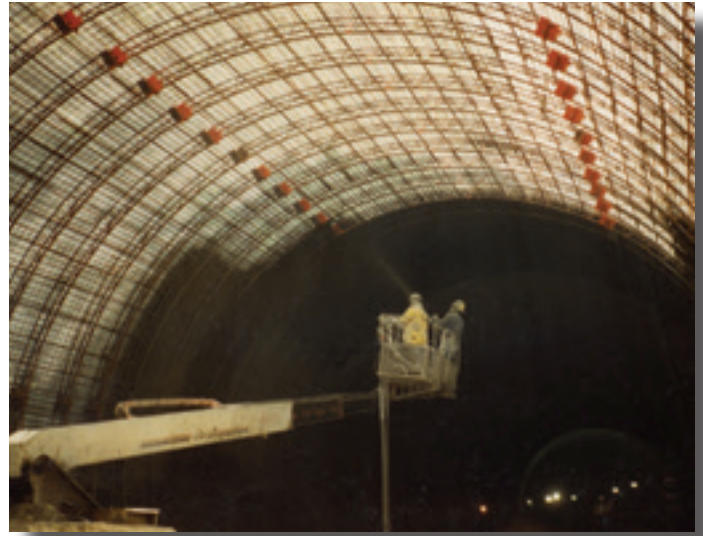

Using Stay-Form as a backstop for shotcrete applications has many advantages. It can be bent to any radius and is easily wire-tied to the reinforcing steel that will form the structure. The open herringbone mesh and V ribs do a great job in catching the shotcrete while minimizing the amount of rebound.

- To visually see both sides of the shotcrete formwork is advantageous.
- The lightweight sheets are user-friendly to install for any shotcrete application.
- Contractors can shotcrete one side of the formwork one day and the other side the following day.



To see more examples of shotcrete applications, visit www.amicoglobal.com and click on *Project Photos*.

Physical Properties of Stay-Form

DESCRIPTION	STANDARD GRADE #66
Galvanized Sheet Thickness	0.0217 in. (0.5512mm)
Sheet Dimensions	27 x 96 in. (686mm x 2438mm)
Weight	0.66 lbs/ft ² (3.22 kg/m ²)
Yield Strength	27.63 ksi (190.50 MPa)
Yield Strain	0.00297
Ultimate Strength	50.28 ksi (346.68 MPa)
Ultimate Strain	0.25
Modulus of Elasticity (E)	29,500 ksi (203,400 MPa)

This data is based on results from testing conducted by an independent testing lab. For more information on the details of the testing, contact AMICO at 800-366-2642.

No proper concrete mix will flow through the openings in Stay-Form on its own.

1) Residual rain water in the form is forced out through the openings in the form.

2) During vibration the blossoming of cement through the openings will show the applicator consolidation is complete and affords the removal of any air pockets.

3) The surface of the Stay-Form after concrete placement is roughened and ready for the next pour. Scabbling or roughening of the exposed surface is not necessary saving valuable time and labor.



TEST DATA

Stay-Form, when used for bulkheads, outperforms traditional plywood for shear bond strength by as much as 21%.

Carlson Testing, Inc.

P.O. Box 23814 • Tigard, Oregon 97281 • Phone (503) 684-3460 • Fax (503) 684-0954

Shear Bond Strength (Modified ASTM C482):

TEST AGE	B-MATTE TOTAL LOAD	B-MATTE SHEAR BOND STRENGTH	STAY-FORM TOTAL LOAD	STAY-FORM SHEAR BOND STRENGTH
5/6 day	15,725 lb.	244.6 psi	26,700 lb.	414.9 psi
13/14 day	12,750 lb.	200.3 psi	16,200 lb.	249.7 psi
27/28 day	15,200 lb.	238.9 psi	19,525 lb.	303.9 psi

The 5/6 day shear bond test data indicated that the Stay-Form #66 test was 41% greater than that of the identically cast test specimen using the B-Matte form board material.

The 13/14 day shear bond test data indicated that the Stay-Form #66 test was 20% greater than that of the identically cast test specimen using the B-Matte form board material.

The 27/28 day shear bond test data indicated that the Stay-Form #66 test was 21% greater than that of the identically cast test specimen using the B-Matte form board material.

Guidelines for Loading & Bracing Spacings

Stay-Form #66

BRACING SPACING (IN. O.C.)	24"	18"	12"
Lateral Loading (psf)	1200	1200	1600
Liquid Head (ft.)	8	8	10
Pour rate (ft./hour)	4	4	7
Maximum Deflection (in.)	1¼	¾	⅛
Recommended lap (in.)	8	6	4
Recommended ties at lap (both ribs)	2	2	1

INSTALLATION NOTES

The AMICO rule of thumb is to “brace Stay-Form like you would a piece of plywood.” The use of rebar, strongbacks, walers, kickers, etc. (location, size and spacing) is similar to that for conventional forming methods per ACI 347, Guide to Formwork for Concrete.

Installation Recommendations:

- The Stay-Form ribs face into the concrete pour
- 4”-8” minimum lap between running Stay-Form sheets
- 2-rib minimum lap between stacked Stay-Form sheets
- Attach Stay-Form to bracing with wire, staples, roofing nails or other mechanical fasteners.
- Tie wire around rib and bracing is recommended.
- Bracing where sheets lap is also recommended.
- Cut Stay-Form sheets with a hand-held grinder, cutoff saw, abrasive blade or metal snips.
- Notch ribs to bend and make virtually any form shape.

Stay-Form Sheet Tie Wire Lap Detail

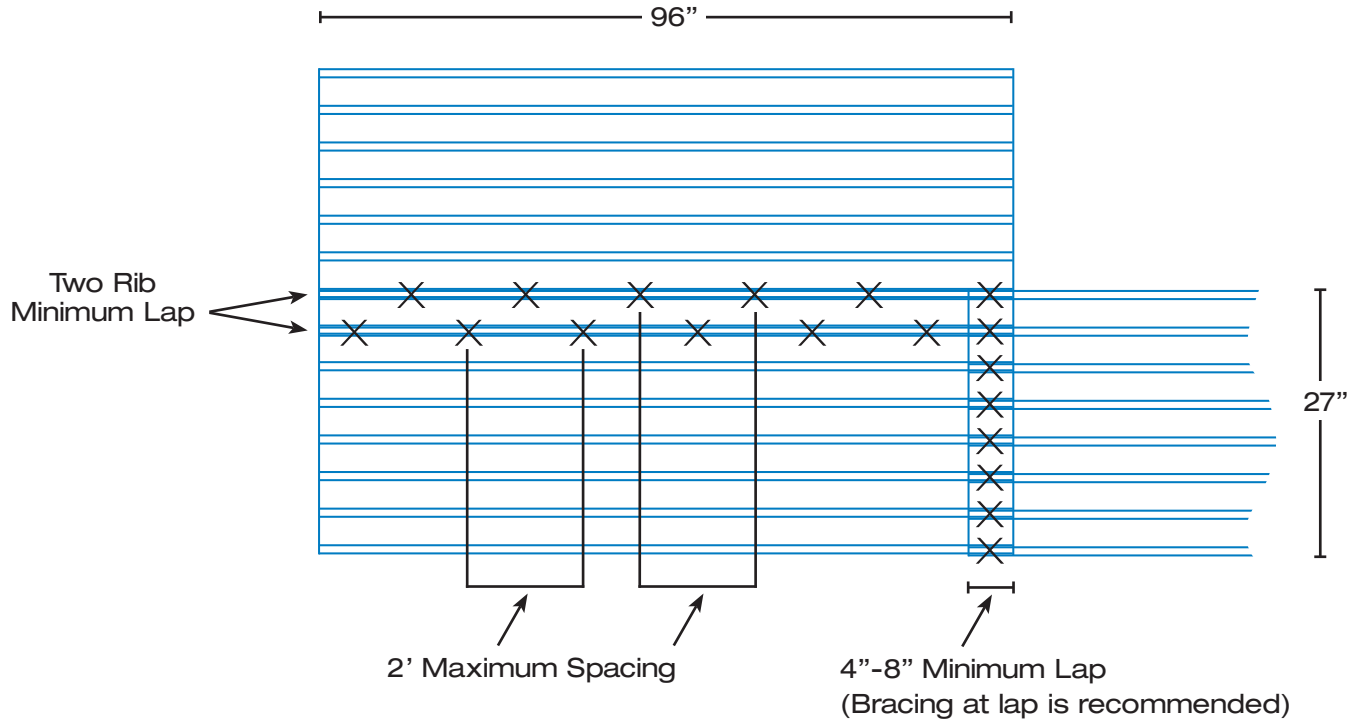

NOTE: X denotes 16-gauge tie wire or sheet metal screws

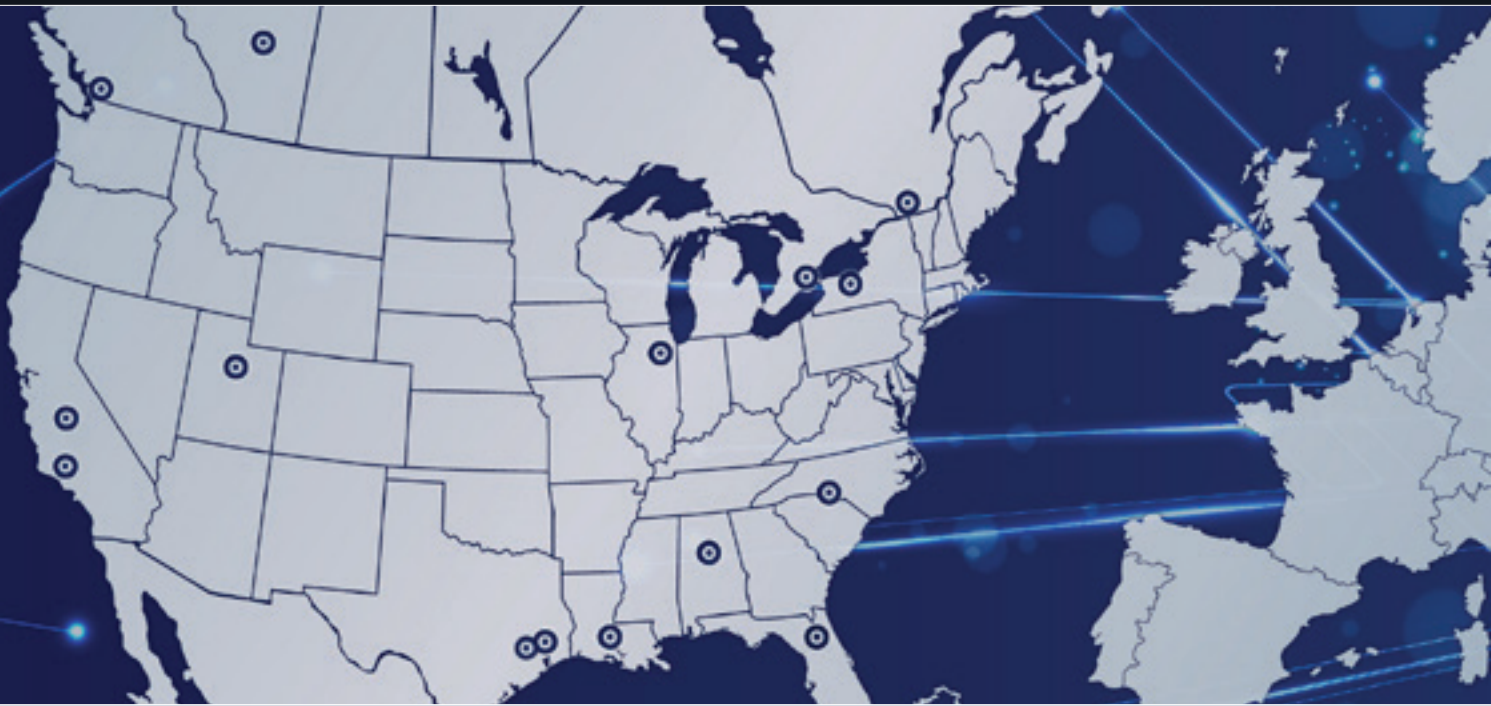

AMICO locations

UNITED STATES

Birmingham, AL
800-366-2642

Bourbonnais, IL
800-238-0322

Dayton, TX
800-622-5765

Fontana, CA
800-962-0100

Houston, TX
800-433-9945

Lakeland, FL
800-487-2511

Orem, UT
800-645-0340

CANADA

Burlington, ON
800-663-4474

Edmonton, AB
855-724-7283

Montreal, QC
800-463-3255

Vancouver, BC
800-665-4474

Seasafe

Lafayette, LA
800-326-8842

Diamond Perforated

Visalia, CA
800-642-4334

Erdle Perforated

Charlotte, NC
800-438-4467

Rochester, NY
800-627-4700



Visit www.amicoglobal.com to view or download data sheets, request a catalog, request LEED information or receive technical assistance.



A GIBRALTAR INDUSTRIES COMPANY 