

Steel Deck

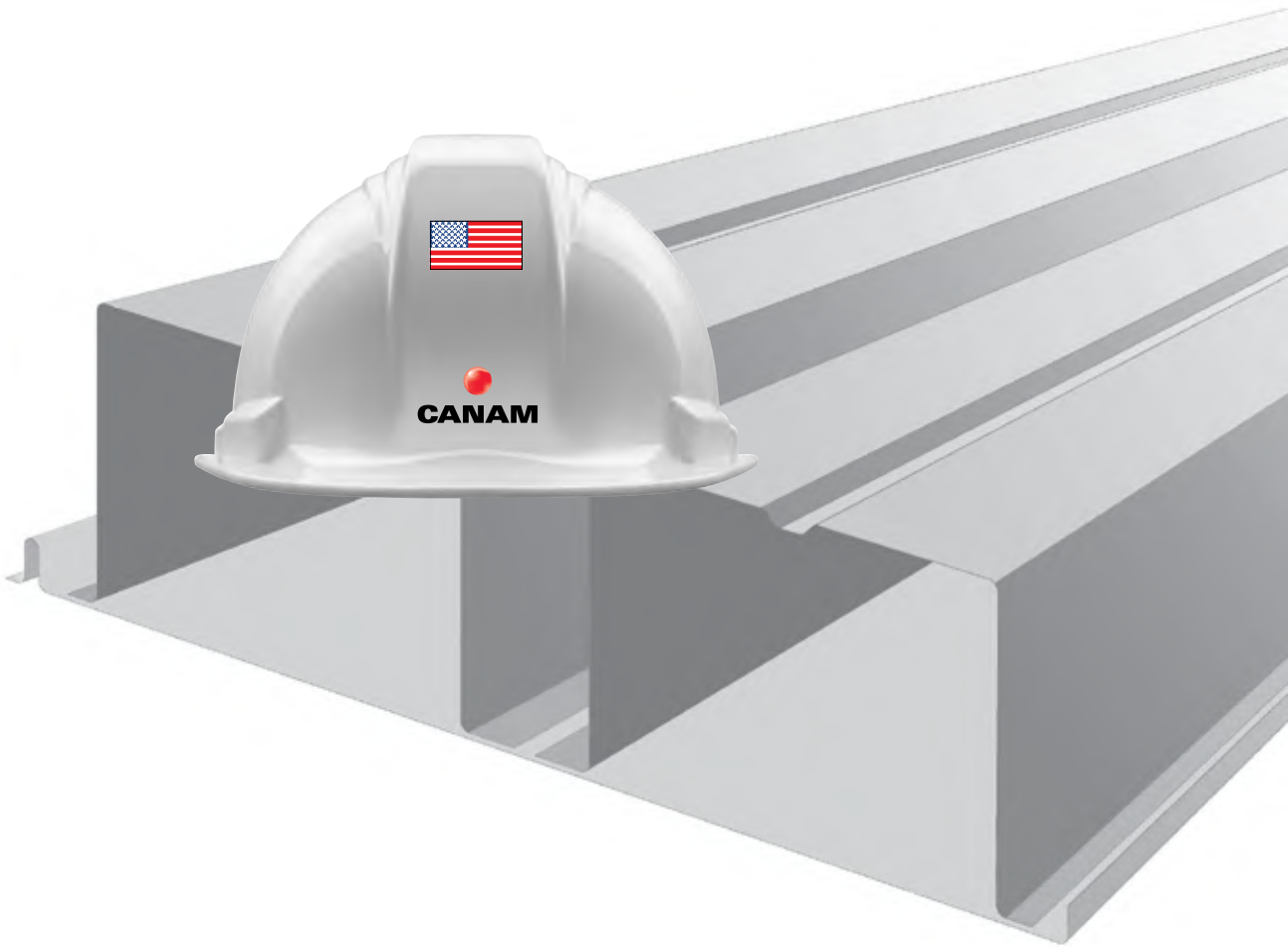

"Manufacturers of  **United Steel Deck** products"

History

Canam is a leading producer of steel deck, short and long span steel joists and joist girders.

United Steel Deck, Inc. (USD) was established in 1968 as a manufacturer of metal roof deck and floor form. The product line was expanded to include composite floor deck, deep roof deck, cellular roof and floor deck and metal wall and roof panels and all related formed-metal deck accessories.

Over a 40 year period, United Steel Deck, Inc. grew into the eastern United States' leading manufacturer of decking products. The original 185,000 square foot facility in South Plainfield, New Jersey was joined in 2000 by a 175,000 square foot manufacturing facility in Peru (Chicago), Illinois.

In August of 2010, United Steel Deck, Inc. was acquired by Canam Steel Corp., headquartered in Point of Rocks, Maryland. Canam designs and manufactures steel deck, steel joists and joist girders and offers value-added engineering, drafting support and customized solutions and service. United Steel Deck, Inc. was integrated with Canam's existing U.S. deck and joist operations. The United Steel Deck brand of Steel Deck Institute (SDI) specified deck products continues to be manufactured at both deck manufacturing facilities (New Jersey & Illinois), as well Canam's Jacksonville, Florida deck and joist manufacturing facility.

In addition to the two (2) deck manufacturing facilities, Canam operates four (4) steel joist fabrication facilities located in Sunnyside, Washington, Jacksonville, Florida, Point of Rocks, Maryland and Washington, Missouri.

For information on any of our products or for the nearest Canam sales representative, please visit us at www.canam.ws.



South Plainfield, NJ



Peru, IL



Jacksonville, FL



This symbol represents areas in our manual which are in LRFD format.



This symbol represents areas in our manual which are in ASD format.

Call for a copy of CSI format deck specifications or visit our website at www.canam.ws.

LEED certification

When a project requires LEED® (Leadership in Energy and Environmental Design) certification, we typically can provide credits in two areas:

1. Sheet steel (in coils) used to manufacture deck is purchased from integrated (BOF) & electric arc furnace (EOF) steel mills, both of which use recycled steel in their manufacturing processes.
2. Our deck manufacturing plants are normally within 500 miles of the job site.

Contact your local Canam Sales Office or visit www.canam.ws for further information on the recycled steel content in our metal deck products.

Introduction

The information presented in this manual has been prepared in accordance with generally accepted engineering principles. The information contained herein conforms to the most recent North American Specification (ANSI/AISI S100-2007). Changes relative to past catalogs reflect this specification and newly ordered yield strengths. We recommend this information not be used or relied upon for any application without a review by a licensed professional engineer, designer, or architect of the proposed application.

Canam makes no representation or warranty with respect to any information contained in this manual, including but not limited to the accuracy, completeness, or suitability of such information for any particular purpose or use. Canam expressly disclaims any and all warranties, expressed or implied. By making this information available, Canam is not rendering professional services, and assumes no duty or responsibility with respect to any person making use of such information. Any party using the information contained in this manual assumes all liability arising from such use.

Since hazards may be associated with the handling, installation or use of steel and its accessories, prudent construction practices should always be followed. We recommend that parties involved in such handling, installation or use review all applicable rules and regulations of the Occupational Safety and Health Administration and other government agencies having jurisdiction over such handling, installation or use, and other relevant construction practice publications.

ROOF DECK	
General Information & Specifications	4
1.5", 3", 4.5" Deck Database	5
1.5", 3", 4.5" Deck Load Tables, ASD & LRFD	6 - 7
1.5", 3", 4.5" Deck Uplift Load Tables	8 - 9
Long Span 4.5", 6", 7.5" Database	10
Long Span 4.5", 6", 7.5" Load Tables	11
Long Span 4.5", 6", 7.5" Uplift Load Tables	12
1.5", 3", 4.5", 6", 7.5" Cellular Deck Database	13
1.5", 3", 4.5", 6", 7.5" Cellular Deck Load Tables, ASD & LRFD	14 - 16
Acoustic Deck	17
Example Problem, Screws, Welds	18 - 20
Curved Deck & Deck Penetrations	21
Details	22
Fire Resistance Ratings	23
SDI Long Form Specifications	24 - 27

FLOOR DECK	
General Information	28
Specifications	29 - 30
Example Problems	31 - 34
N-Lok	35
B-Lok	36 - 37, 46 - 47
Inverted B-Lok	38 - 39, 48 - 49
1.5" Lok-Floor	40 - 41, 50 - 51
2" Lok-Floor	42 - 43, 52 - 53
3" Lok-Floor	44 - 45, 54 - 55
Details	56 - 57
Composite Beam and Joist Details	58 - 59
Negative Bending Information	60
Pour Stops, Hangers	61
Cellular Floor Deck Database	62
Fire Resistance Ratings	63 - 65
SDI Long Form Specifications	66 - 71

FORM DECK	
General Information	72
Weld Patterns, Specifications	73
UFS, ASD & LRFD	74
UF1X, ASD & LRFD	75
UFX, ASD & LRFD	76
UF2X, ASD & LRFD	77
LF2X, ASD & LRFD	78
LF3X, ASD & LRFD	79
HPD, ASD & LRFD and LS used as concrete form	80
Concrete Volumes and Slab Design Data	81
Concrete Slabs on Form Deck	82 - 83
UFS, UF1X, UFX, UF2X Maximum Span and Cantilever Tables	84
Slab and Reinforcement Data	85
Fire Resistance Ratings	86
SDI Long Form Specifications	87 - 91

DIAPHRAGM	
Introduction	92
Diaphragm Design Example	93
Typical Fastener Layout	94
1.5" B, F, 3" N	95 - 121
Composite Deck NW & LW	122 - 129
Form Deck NW & LW, Type 1 & 2 Fill	130 - 153

MISCELLANEOUS INFORMATION	
SDI Code of Standard Practice	154 - 159
Custom Shapes, Metric Conversion	160
Common Finishes	161
Bibliography	162
Canam Bill of Materials	163
Engineering Office Listings	164
Deck and Joist Plant Listings	165

TABLE OF CONTENTS

General Information

SECTION PROPERTIES

Section properties are per foot of width. The subscripts p and n refer to positive and negative bending. For deflection calculations, only the I_p is used but it would be permitted to average I_p and I_n on all multispan conditions or to use I_p for single span uplift loads. Published deflection loads may be adjusted. Maximum recommended cantilevers are determined using I_n .

LOAD TABLES

Deck must be properly fastened to resist all loads including construction loads. Two types of load tables are shown; the difference is design philosophy. **Allowable Stress Design (ASD)** tables show (**strength / deflection**) loads in psf. The strength load is limited by a bending stress of 24 ksi (20 ksi for cellular deck). The strength is the least of all design limit states – positive bending, negative bending and shear interaction, and web crippling at either interior or exterior supports. Web crippling considers 2 inch bearing at exterior and 4 inch bearing at interior supports. Canam recommends using a 2 inch minimum for exterior bearing to ensure a safe connection. Web crippling is not considered in uplift calculation. The deflection load produces $L/240$ deflection and is based on the positive moment of inertia calculated at a stress level of 24 ksi (20 ksi for cellular deck). For deck spans over 20 feet, a deflection limit of 1 inch controls. **Load Resistance Factor Design (LRFD)** tables also show (**strength / deflection**) loads. The bending stress is limited to ϕF_y where ϕ is .95 and F_y is 40 ksi. The LRFD strength is the factored load resistance. The roof deck data base shows the factored resistances for LRFD and the allowable resistances for ASD. The deflection load is the same for ASD and LRFD. Since service load is critical for deflection, that load resistance should be compared with the true service load. The load combinations that are to be investigated are discussed on page 18.

For multi span conditions the shear and bending interaction over interior supports often controls strength. The shear and bending interaction equations for ASD and LRFD are:

$$\text{ASD} \quad \left(\frac{M_{\text{applied}}}{M_{\text{allowable}}} \right)^2 + \left(\frac{V_{\text{applied}}}{V_{\text{allowable}}} \right)^2 \leq 1 \quad \text{LRFD} \quad \left(\frac{M_{\text{factored}}}{\phi_b M_n} \right)^2 + \left(\frac{V_{\text{factored}}}{\phi_v V_n} \right)^2 \leq 1$$

where LRFD uses factored loads and factored nominal resistances.

The tables consider uniform loads over equal spans with all spans loaded. For unequal spans, the moments, shears, and deflections may be calculated using standard analysis methods. The data base provides the information needed to calculate resistance loads for either ASD or LRFD at any span combination. For roof deck, spans are taken as the center to center spacing of supports.

MAXIMUM SPANS

Maximum recommended SDI spans (and cantilevers) for roofing applications are shown on pages 5, 10 and 13. These are serviceability based; see ANSI/SDI – RD1.0 *Standard for Steel Roof Deck* for the criteria - page 25. Deck used for other purposes (such as siding or shelving) may have different limits – special tables can be prepared on request. The Factory Mutual Global (FM) maximum spans are for Class 1 roof constructions and are serviceability based. FM has different criteria and special fastener patterns are required to resist uplift at supports. Special side lap fastener patterns are also required. Consult FM1-28 and FM1-29 for uplift tables to determine maximum spans controlled by flexure. Corner and perimeter zones either may require shorter spans than the roof field or varied gages. Specify Grade 80 steel and two FM approved deck fasteners per rib for FM ratings greater than 1-90.

ACOUSTIC DECK

Types BA, BIA, NSA, NIA, JA, HA6, HA7.5 are acoustic decks. The holes in the deck webs will not significantly reduce the deck strength but it is estimated that the stiffness for both vertical and horizontal loads will be reduced about 5%. Cellular acoustic decks are also available.

CURVED DECK

Types B and BA are available shop curved in 22, 20 and 18 gage. The cover width is nominally 24". The minimum bend radius is 24 feet. Both B and NS families of deck can be crimp curved to lesser radii. **Cellular deck cannot be shop curved.** Guide lines are provided on page 21 for the field curving of deck. For conditions outside these limits, consult Canam engineering.

INSULATION

Insulation board should have sufficient strength and stiffness to span the rib openings. Cementitious insulation fills should only be used with galvanized deck and must be adequately vented. **Vented B and N decks** are available. (See the vented paragraph on page 73 of the form deck section in this manual for available area and other vented products.) Insulation must be compatible with steel deck.

SPECIAL FINISHES

Special colors or finishes can be provided for all roof deck profiles shown in this catalog. (The standard paint is a top coat primer – see the specifications for the description).

In order to provide a "finish" coat at an economical price, the order should be a minimum of 25,000 square feet. When installing deck with a special finish, screwed side laps are recommended, and in most instances, screws, pneumatic, or powder driven fasteners should be used at the supports. Care must be taken during storage and installation to avoid marring.

FASTENERS

Although welds are the most common fastenings of roof deck to open web joists or structural steel, other fastening methods are acceptable. Powder or pneumatically driven pins and self drilling screws are also frequently used. Uplift and shear values for these fasteners can be obtained from the fastener manufacturer. Weld washers are not necessary and are not recommended for the roof deck gages (22 and heavier) shown in this manual. Cold formed steel supports commonly require screws.

DIAPHRAGMS

Diaphragm strengths and stiffness based on the **SDI Diaphragm Design Manual** are available. See the Diaphragm section in this catalog.

TOLERANCE

The standard length tolerance for roof deck panels is plus or minus 1/2". The base steel thickness tolerance is minus 5% as per the SDI and AISI.

Suggested Specifications

1. Material and Design - Steel roof deck shall be **United Steel Deck B, F, N, J, H** or LS profiles as manufactured by **Canam** and shall be made from steel conforming to ASTM Designations A1008 SS 40, 50 or 80 (for painted deck) or A653 Grade 40, 50 or 80 (for galvanized deck). The minimum yield strength is 40,000 psi. The deflection of the deck under design live load shall not exceed 1/240 of the span or 1", whichever is less. (Span is measured center line to center line of supports). Section properties used in determining stress and deflection shall have been calculated in accordance with the American Iron and Steel Institute's **North American Specification for the Design of Cold-Formed Steel Structural Members**. Coefficients for moments and deflections shall conform to the **Steel Deck Institute's Design Manual for Composite Decks, Form Decks and Roof Decks and the ANSI/SDI-RD1.0 Standard for Steel Roof Deck**. Suspended loads (when required) shall be considered in the design and shall not exceed the value shown in the contract documents. Uplift loads (when required) shall be considered in the design and fasteners shall conform to the schedules shown in the contract documents.

2. Finishes - Galvanizing shall conform to the requirements of ASTM A653 coating class G30, G60, G90. **OR...**A shop coat of primer paint shall be applied over cleaned and phosphatized steel. (This primer coat is intended to protect the steel for only a short period of exposure in ordinary atmospheric conditions and must be considered an impermanent coating). **OR...**A shop coat of primer paint shall be applied over cleaned and phosphatized galvanized steel. Galvanizing shall conform to ASTM A653 coating class G30, G60, or G90. *For additional information on finishes see page 161.*

3. Installation - Steel Deck shall be erected and fastened in accordance with the project's specifications, the approved erection layouts, and the **SDI Manual of Construction with Steel Deck**. Cutting openings through the deck less than 25 square feet in area, and all skew cutting, shall be performed in the field. Arc puddle welds shall be at least 5/8 inch in diameter, or elongated, having an equal perimeter. *Nominal 5/8 inch diameter arc-spot welds of good quality are more efficiently obtained in metals thicker than 0.028 inches than are welds through weld washers, thus washers are not recommended for panels having thicknesses of 0.028 inches or greater.* Fillet welds (when used) shall be 1 1/2 inch long. Weld metal shall penetrate all layers of deck material at end laps and side joints and have good fusion to the supporting members. Support arc puddle welds shall be 3/4 inch diameter or elongated arc seam welds having equal perimeter when either the combined thickness at end laps or at each support for cellular deck exceeds 20/18. Welds shall be 3/4 inch for single thickness equal to or greater than 12 gage. Fastening at supports shall be at all edge ribs. Space additional welds an average of 12 inches apart but not more than 18 inches (8 inches for N deck, 12 inches for J, H, LS decks). Side laps of individual sheets must be fastened together between supports for spans greater than 5 feet; the fastener spacing shall not exceed 3 feet on center. Deck shall be supported at starting and ending edges parallel to the deck span and shall be fastened to the support at the specified side lap spacing. End laps (when required) of sheets shall be a minimum of 2 inches (1 inch on each side of its centerline) and shall occur over supports. When supports are steel joists, the minimum end lap shall be 4 inches. J, H, LS, BI and NI deck shall be butted, not lapped. Minimum end bearing is 1 1/2 inch.

4. Accessories - Ridge and valley cover plates and flat plates at change of deck direction (when attached directly to the steel deck and as shown on contract documents), shall be furnished by Canam.

GENERAL INFORMATION

Data Base - Type B, F, N, J



Note:
Fy = 40 ksi

ROOF DECK DATA BASE																
ATTRIBUTE		TYPE B DECK (B, BI, BA, BIA)				TYPE F DECK			TYPE N DECK (NS, NI, NSA, NIA)				TYPE J DECK (J, JA)			
Note	Gage	22	20	18	16	22	20	18	22	20	18	16	20	19	18	16
	Thickness	.0295	.0358	.0474	.0598	.0295	.0358	.0474	.0295	.0358	.0474	.0598	.0358	.0418	.0474	.0598
	Weight, psf	1.6	1.9	2.6	3.3	1.6	2.0	2.6	2.0	2.4	3.2	4.1	2.8	3.3	3.8	4.8
1	I _p , in. ⁴	0.16	0.20	0.29	0.38	0.13	0.16	0.24	0.61	0.79	1.14	1.56	2.28	2.79	3.31	4.42
1	I _n , in. ⁴	0.18	0.23	0.30	0.38	0.15	0.18	0.24	0.82	1.02	1.35	1.70	2.73	3.20	3.63	4.57
1	S _p , in. ³	0.19	0.23	0.32	0.41	0.13	0.16	0.22	0.36	0.47	0.65	0.85	0.88	1.10	1.27	1.64
1	S _n , in. ³	0.19	0.24	0.32	0.41	0.14	0.17	0.23	0.40	0.51	0.70	0.90	0.97	1.17	1.35	1.71
2	Ext.R, lbs.	710	1010	1680	2560	710	1010	1680	510	730	1230	1900	460	620	780	1210
3	Ext.R, lbs.	820	1160	1920	2910	820	1160	1910	590	840	1400	2150	530	710	890	1380
4	Int.R, lbs.	1130	1640	2780	4300	1340	1900	3170	1010	1450	2430	3720	970	1290	1620	2480
5	Int.R, lbs.	1130	1640	2780	4300	1340	1910	3180	1090	1560	2600	3980	1040	1380	1740	2650
6	V, lbs.	1860	2250	2960	3700	2250	2730	3590	2430	3580	5620	7060	2000	3190	4230	6730
7	Max.1 span	5'9"	6'5"	7'9"	8'10"	5'2"	5'9"	7'0"	11'2"	12'9"	15'3"	17'11"	19'6"	20'8"	21'7"	23'2"
8	Max.2 span	6'9"	7'6"	9'1"	10'5"	6'1"	6'9"	8'3"	13'2"	15'0"	18'0"	20'8"	23'0"	24'3"	25'3"	27'2"
9	Max. Cant.	1'8"	1'10"	2'2"	2'8"	1'6"	1'8"	1'11"	3'4"	3'8"	4'4"	4'10"	5'9"	6'2"	6'6"	7'2"
10	FM span	6'0"	6'6"	7'5"	9'6"	4'11"	5'5"	6'3"	10'10"	12'3"	14'7"	16'6"				
10	FM Acoustic span	5'11"	6'6"	7'5"	9'3"				10'7"	11'11"	14'3"	16'1"				

Data Base - Type B, F, N, J



ROOF DECK DATA BASE																
ATTRIBUTE		TYPE B DECK (B, BI, BA, BIA)				TYPE F DECK			TYPE N DECK (NS, NI, NSA, NIA)				TYPE J DECK (J, JA)			
Note	Gage	22	20	18	16	22	20	18	22	20	18	16	20	19	18	16
	Thickness	.0295	.0358	.0474	.0598	.0295	.0358	.0474	.0295	.0358	.0474	.0598	.0358	.0418	.0474	.0598
	Weight, psf	1.6	1.9	2.6	3.3	1.6	2.0	2.6	2.0	2.4	3.2	4.1	2.8	3.3	3.8	4.8
1	I _p , in. ⁴	0.16	0.20	0.29	0.38	0.13	0.16	0.24	0.61	0.79	1.14	1.56	2.28	2.79	3.31	4.42
1	I _n , in. ⁴	0.18	0.23	0.30	0.38	0.15	0.18	0.24	0.82	1.02	1.35	1.70	2.73	3.20	3.63	4.57
1	S _p , in. ³	0.19	0.23	0.32	0.41	0.13	0.16	0.22	0.36	0.47	0.65	0.85	0.88	1.10	1.27	1.64
1	S _n , in. ³	0.19	0.24	0.32	0.41	0.14	0.17	0.23	0.40	0.51	0.70	0.90	0.97	1.17	1.35	1.71
2	Ext.R, lbs.	1080	1540	2570	3920	1090	1550	2570	780	1120	1890	2900	700	950	1200	1860
3	Ext.R, lbs.	1250	1770	2930	4450	1250	1770	2930	900	1290	2150	3280	810	1080	1370	2100
4	Int.R, lbs.	1690	2440	4140	6390	1990	2830	4720	1510	2160	3610	5530	1440	1910	2410	3700
5	Int.R, lbs.	1690	2440	4140	6390	2000	2850	4730	1620	2320	3870	5910	1550	2050	2580	3950
6	V, lbs.	2830	3420	4500	5620	3430	4140	5450	3700	5450	8540	10730	3040	4840	6430	10230
7	Max.1 span	5'9"	6'5"	7'9"	8'10"	5'2"	5'9"	7'0"	11'2"	12'9"	15'3"	17'11"	19'6"	20'8"	21'7"	23'2"
8	Max.2 span	6'9"	7'6"	9'1"	10'5"	6'1"	6'9"	8'3"	13'2"	15'0"	18'0"	20'8"	23'0"	24'3"	25'3"	27'2"
9	Max. Cant.	1'8"	1'10"	2'2"	2'8"	1'6"	1'8"	1'11"	3'4"	3'8"	4'4"	4'10"	5'9"	6'2"	6'6"	7'2"
10	FM span	6'0"	6'6"	7'5"	9'6"	4'11"	5'5"	6'3"	10'10"	12'3"	14'7"	16'6"				
10	FM Acoustic span	5'11"	6'6"	7'5"	9'3"				10'7"	11'11"	14'3"	16'1"				

ROOF DECK DATABASE NOTES:

- I_p, I_n, S_p, and S_n are the section properties per foot of width. These values were calculated using the AISI Specifications. The subscripts denote positive or negative bending.
- Allowable end reaction per foot of deck width with 2" bearing for ASD and the factored nominal reaction for LRFD.
- Allowable end reaction per foot of deck width with 3" bearing for ASD and the factored nominal reaction for LRFD.
- Allowable interior reaction per foot of deck width with 4" bearing for ASD and the factored nominal reaction for LRFD.
- Allowable interior reaction per foot of deck width with 5" bearing for ASD and the factored nominal reaction for LRFD.
- Allowable vertical shear per foot of width and the factored nominal shear for LRFD. Do not confuse this with horizontal diaphragm shear strength. Table values of 2, 3, 4, 5 and 6 have been multiplied by the appropriate φ factor for the LRFD tables.
- Maximum recommended single span for roofs.
- Maximum recommended multi span for roofs.
- Maximum recommended cantilever span based on SDI criteria. Values are sensitive to adjacent spans as they are controlled by deflection. For this table, adjacent spans are assumed to be at least 2 times greater than the cantilever span. Call if you need a more precise calculation.
- Maximum spans for Factory Mutual Class 1 construction. Refer to the FM Approval Guide and FM 1-29 for fastening requirements and span restrictions at perimeter.

GENERAL NOTES:

- B is generally known as "wide rib" deck; F is "intermediate rib", the 3" N is "deep rib" and the 4 1/2" J is one of the "deep long span" decks.
- The deck type B means flat side lap; BI is "interlocking" side lap - BI is only available on special order in 16 gage; BA and BIA means the decks are acoustical. F deck is only available with the flat side lap. F is only available on special order in 16 gage. NS is flat side lap and NI is interlocking. J deck is only available with interlocking side laps. NA, NIA and JA are acoustical decks. Better side lap connections are obtained by screwing or welding through the flat side laps and this is the recommended type. Side lap screws are not possible for J Deck. Both sides of interlocking side lap must be fastened at supports.
- Information not provided on this chart may be obtained from Canam Engineering offices.
- 21 gage and 19 gage are available on special order for all 1 1/2" and 3" roof decks.

Type B, BI, BA, BIA Wide Rib Deck

Note:
Fy = 40 ksi

TYPE B

TYPE BI

Uniform Total Load, psf/Load Producing L/240 or 1", psf											
Span Condition	Gage	Span (ft. - in.) C. to C. of Support									
		5'0"	5'6"	6'0"	6'6"	7'0"	7'6"	8'0"	8'6"	9'0"	9'6"
Single	22	122/84	100/63	84/49							
	20	147/105	122/79	102/61	87/48						
	18	205/152	169/114	142/88	121/69	104/56	91/45	80/37			
	16	262/200	217/150	182/116	155/91	134/73	117/59	103/49	91/41	81/34	
Double	22	119/202	99/152	83/117	71/92	61/74					
	20	150/253	125/190	105/146	90/115	77/92	68/75				
	18	200/367	166/276	140/212	120/167	103/134	90/109	79/90	70/75	63/63	56/53
	16	256/481	213/361	179/278	153/219	132/175	115/142	102/117	90/98	80/82	72/70
Triple	22	148/158	123/119	103/92	88/72	76/58					
	20	186/198	155/149	130/115	111/90	96/72	84/59				
	18	248/287	206/216	174/166	149/131	128/105	112/85	99/70	88/58	78/49	70/42
	16	317/376	263/283	222/218	190/171	164/137	144/111	126/92	112/77	100/64	90/55

Uniform Total Load, psf/Load Producing L/240 or 1", psf											
Span Condition	Gage	Span (ft. - in.) C. to C. of Support									
		5'0"	5'6"	6'0"	6'6"	7'0"	7'6"	8'0"	8'6"	9'0"	9'6"
Single	22	193/84	159/63	134/49							
	20	233/105	193/79	162/61	138/48						
	18	324/152	268/114	225/88	192/69	165/56	144/45	127/37			
	16	415/200	343/150	289/116	246/91	212/73	185/59	162/49	144/41	128/34	
Double	22	188/202	156/152	132/117	112/92	97/74					
	20	237/253	197/190	166/146	142/115	123/92	107/75				
	18	316/367	263/276	221/212	189/167	163/134	143/109	125/90	111/75	99/63	89/53
	16	405/481	336/361	283/278	242/219	209/175	183/142	161/117	142/98	127/82	114/70
Triple	22	233/158	194/119	163/92	140/72	121/58					
	20	294/198	244/149	206/115	176/90	152/72	133/59				
	18	391/287	325/216	275/166	235/131	203/105	177/85	156/70	139/58	124/49	111/42
	16	500/376	416/283	351/218	301/171	260/137	227/111	200/92	177/77	158/64	142/55

Areas marked with this symbol exceed SDI recommended maximum spans. (see database)



Type F, Intermediate Rib Deck

TYPE F

Uniform Total Load, psf/Load Producing L/240 or 1", psf											
Span Condition	Gage	Span (ft. - in.) C. to C. of Support									
		4'0"	4'6"	5'0"	5'6"	6'0"	6'6"	7'0"	7'6"	8'0"	8'6"
Single	22	130/133	103/94	83/68	69/51						
	20	160/164	126/115	102/84	85/63	71/49					
	18	220/246	174/173	141/126	116/95	98/73	83/57	72/46			
Double	22	138/321	110/226	89/164	74/124	62/95	53/75				
	20	168/395	133/278	108/202	89/152	75/117	64/92	55/74			
	18	227/593	180/416	146/303	121/228	102/176	87/138	75/111	65/90	57/74	51/62
Triple	22	172/251	136/176	111/129	92/97	77/74	66/59				
	20	209/309	166/217	135/158	111/119	94/92	80/72	69/58			
	18	282/464	224/326	182/238	151/178	127/137	108/108	93/87	81/70	72/58	63/48

Uniform Total Load, psf/Load Producing L/240 or 1", psf											
Span Condition	Gage	Span (ft. - in.) C. to C. of Support									
		4'0"	4'6"	5'0"	5'6"	6'0"	6'6"	7'0"	7'6"	8'0"	8'6"
Single	22	206/133	163/94	132/68	109/51						
	20	253/164	200/115	162/84	134/63	113/49					
	18	348/246	275/173	223/126	184/95	155/73	132/57	114/46			
Double	22	219/321	173/226	141/164	116/124	98/95	84/75				
	20	266/395	210/278	171/202	141/152	119/117	101/92	88/74			
	18	359/593	285/416	231/303	191/228	161/176	137/138	118/111	103/90	91/74	80/62
Triple	22	272/251	216/176	175/129	145/97	122/74	104/59				
	20	330/309	262/217	213/158	176/119	148/92	127/72	109/58			
	18	446/464	354/326	288/238	238/178	201/137	171/108	148/87	129/70	113/58	100/48



Note:
Fy = 40 ksi

Type NS, NI, NSA, NIA Deep Rib Deck

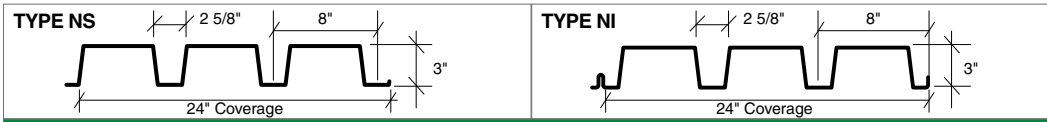

(Uniform Total Load, psf/Load Producing L/240 or 1", psf)												
Span Condition	Gage	Span (ft. - in.) C. to C. of Support										
		10'0"	10'6"	11'0"	11'6"	12'0"	12'6"	13'0"	13'6"	14'0"	14'6"	15'0"
Single	22	58/40	52/35	48/30	44/26							
	20	75/52	68/45	62/39	57/34	52/30	48/27	44/24				
	18	104/75	94/65	86/56	79/49	72/43	67/38	62/34	57/30	53/27	49/25	46/22
	16	136/102	123/88	112/77	103/67	94/59	87/52	80/47	75/42	69/37	65/34	60/30
Double	22	63/96	57/83	52/72	48/63	44/56	41/49	38/44	35/39			
	20	81/125	73/108	67/94	61/82	56/72	52/64	48/57	45/51	41/46	39/41	36/37
	18	111/180	101/156	92/135	84/118	77/104	71/92	66/82	61/73	57/66	53/59	50/53
	16	143/247	130/213	118/185	108/162	99/143	92/126	85/112	79/100	73/90	68/81	64/73
Triple	22	78/75	71/65	65/57	60/50	55/44	51/39	47/34	43/31			
	20	101/98	91/84	83/73	76/64	70/57	65/50	60/44	56/40	52/36	48/32	45/29
	18	138/141	126/122	115/106	105/93	96/82	89/72	82/64	76/57	71/51	66/46	62/42
	16	178/193	162/167	147/145	135/127	124/112	114/99	106/88	98/78	91/70	85/63	80/57



(Uniform Total Load, psf/Load Producing L/240 or 1", psf)												
Span Condition	Gage	Span (ft. - in.) C. to C. of Support										
		10'0"	10'6"	11'0"	11'6"	12'0"	12'6"	13'0"	13'6"	14'0"	14'6"	15'0"
Single	22	91/40	83/35	75/30	69/26							
	20	119/52	108/45	98/39	90/34	83/30	76/27	70/24				
	18	165/75	149/65	136/56	125/49	114/43	105/38	97/34	90/30	84/27	78/25	73/22
	16	215/102	195/88	178/77	163/67	150/59	138/52	127/47	118/42	110/37	102/34	96/30
Double	22	100/96	91/83	83/72	76/63	70/56	64/49	59/44	55/39			
	20	128/125	116/108	106/94	97/82	89/72	82/64	76/57	70/51	66/46	61/41	57/37
	18	176/180	160/156	146/135	133/118	122/104	113/92	104/82	97/73	90/66	84/59	79/53
	16	226/247	205/213	187/185	171/162	157/143	145/126	134/112	125/100	116/90	108/81	101/73
Triple	22	124/75	113/65	103/57	94/50	87/44	80/39	74/34	69/31			
	20	159/98	144/84	132/73	121/64	111/57	102/50	95/44	88/40	82/36	76/32	71/29
	18	219/141	199/122	181/106	166/93	153/82	141/72	130/64	121/57	112/51	105/46	98/42
	16	281/193	256/167	233/145	213/127	196/112	181/99	167/88	155/78	144/70	135/63	126/57



Areas marked with this symbol exceed SDI recommended maximum spans. (see database)

Type J, JA Deep Long Span Roof Deck (4 1/2" Deep)

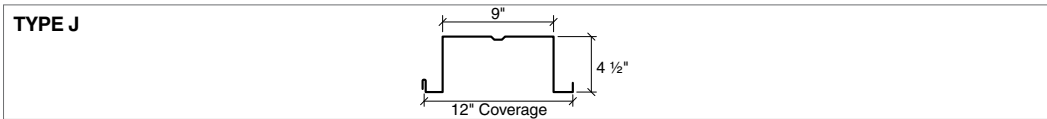

(Uniform Total Load, psf/Load Producing L/240 or 1", psf)												
Span Condition	Gage	Span										
		10'0"	11'0"	12'0"	13'0"	14'0"	15'0"	16'0"	17'0"	18'0"	19'0"	20'0"
Single	20	92/150	84/112	77/87	71/68	66/55	61/44	55/37	49/30	43/26	39/22	35/19
	19	124/183	113/138	103/106	95/83	89/67	78/54	69/45	61/37	54/31	49/27	44/23
	18	156/217	142/163	130/126	120/99	104/79	90/64	79/53	70/44	63/37	56/32	51/27
	16	242/290	217/218	182/168	155/132	134/106	117/86	103/71	91/59	81/50	73/42	66/36
Double	20	78/360	71/271	65/209	60/164	55/131	52/107	49/88	46/73	43/62	41/53	38/45
	19	103/441	94/331	86/255	79/201	74/161	69/131	65/108	61/90	57/76	51/64	46/55
	18	130/523	118/393	108/303	100/238	93/191	86/155	81/128	73/106	66/90	59/76	53/65
	16	198/699	180/525	165/404	153/318	137/255	120/207	106/171	94/142	84/120	75/102	68/87
Triple	20	88/282	80/212	73/163	68/128	63/103	59/84					
	19	117/345	107/259	98/200	90/157	84/126	78/102					
	18	147/409	134/308	123/237	113/186	105/149	98/121					
	16	225/547	205/411	188/316	173/249	161/199	149/162					



Areas marked with this symbol represent impractical spans.

(Uniform Total Load, psf/Load Producing L/240 or 1", psf)												
Span Condition	Gage	Span										
		10'0"	11'0"	12'0"	13'0"	14'0"	15'0"	16'0"	17'0"	18'0"	19'0"	20'0"
Single	20	140/150	127/112	117/87	108/68	100/55	93/44	87/37	77/30	69/26	62/22	56/19
	19	190/183	173/138	158/106	146/83	136/67	124/54	109/45	96/37	86/31	77/27	70/23
	18	240/217	218/163	200/126	185/99	164/79	143/64	126/53	111/44	99/37	89/32	80/27
	16	372/290	338/218	289/168	246/132	212/106	185/86	162/71	144/59	128/50	115/42	104/36
Double	20	115/360	105/271	96/209	89/164	82/131	77/107	72/88	68/73	64/62	61/53	58/45
	19	153/441	139/331	127/255	118/201	109/161	102/131	96/108	90/90	85/76	80/64	73/55
	18	193/523	175/393	161/303	148/238	138/191	129/155	121/128	113/106	104/90	93/76	84/65
	16	296/699	269/525	247/404	228/318	211/255	190/207	167/171	148/142	132/120	119/102	107/87
Triple	20	131/282	119/212	109/163	101/128	94/103	87/84					
	19	174/345	158/259	145/200	134/157	124/126	116/102					
	18	219/409	199/308	183/237	169/186	156/149	146/121					
	16	336/547	306/411	280/316	259/249	240/199	224/162					



Yellow shading indicates areas where web crippling controls.

B, BI, BA, BIA Deck Uplift

Note:
Fy = 40 ksi

TYPE B

6" 2 1/2" 1 1/2"

36" Coverage (B36)
(30" Coverage (B30) and (BI30) is also available)

TYPE BI

36" Coverage (BI36)

(Uniform Total Load, psf/Load Producing L/240 or 1", psf)											
Span Condition	Gage	Span									
		5'0"	5'6"	6'0"	6'6"	7'0"	7'6"	8'0"	8'6"	9'0"	9'6"
Single	22	122/84	100/63	84/49							
	20	154/105	127/79	107/61	91/48						
	18	205/152	169/114	142/88	121/69	104/56	91/45	80/37			
	16	262/200	217/150	182/116	155/91	134/73	117/59	103/49	91/41	81/34	
Double	22	119/202	99/152	83/117	71/92	61/74					
	20	144/253	120/190	101/146	86/115	74/92	65/75				
	18	200/367	166/276	140/212	120/167	103/134	90/109	79/90	70/75	63/63	56/53
	16	256/481	213/361	179/278	153/219	132/175	115/142	102/117	90/98	80/82	72/70
Triple	22	148/158	123/119	103/92	88/72	76/58					
	20	179/198	148/149	125/115	107/90	92/72	81/59				
	18	248/287	206/216	174/166	149/131	128/105	112/85	99/70	88/58	78/49	70/42
	16	317/376	263/283	222/218	190/171	164/137	144/111	126/92	112/77	100/64	90/55

(Uniform Total Load, psf/Load Producing L/240 or 1", psf)											
Span Condition	Gage	Span									
		5'0"	5'6"	6'0"	6'6"	7'0"	7'6"	8'0"	8'6"	9'0"	9'6"
Single	22	193/84	159/63	134/49							
	20	243/105	201/79	169/61	144/48						
	18	324/152	268/114	225/88	192/69	165/56	144/45	127/37			
	16	415/200	343/150	289/116	246/91	212/73	185/59	162/49	144/41	128/34	
Double	22	188/202	156/152	132/117	112/92	97/74					
	20	228/253	189/190	159/146	136/115	118/92	103/75				
	18	316/367	263/276	221/212	189/167	163/134	143/109	125/90	111/75	99/63	89/53
	16	405/481	336/361	283/278	242/219	209/175	183/142	161/117	142/98	127/82	114/70
Triple	22	233/158	194/119	163/92	140/72	121/58					
	20	282/198	235/149	198/115	169/90	146/72	128/59				
	18	391/287	325/216	275/166	235/131	203/105	177/85	156/70	139/58	124/49	111/42
	16	500/376	416/283	351/218	301/171	260/137	227/111	200/92	177/77	158/64	142/55

Areas marked with this symbol exceed SDI recommended maximum spans. (see database)



F Deck Uplift

Web crippling is considered at gravity loads but is not considered a limit state during uplift. Fasteners must be designed separately for uplift and/or diaphragm shear.

TYPE F

6" 1 3/4" 1 1/2"

30" Coverage (F30) also available
36" Coverage

(Uniform Total Load, psf/Load Producing L/240 or 1", psf)											
Span Condition	Gage	Span									
		4'0"	4'6"	5'0"	5'6"	6'0"	6'6"	7'0"	7'6"	8'0"	8'6"
Single	22	140/133	111/94	90/68	74/51						
	20	170/164	134/114	109/84	90/63	76/49					
	18	230/246	182/173	147/126	122/95	102/73	87/57	75/46			
Double	22	129/321	102/226	83/164	68/124	58/95	49/75				
	20	158/395	125/278	102/202	84/152	71/117	60/92	52/74			
	18	217/593	172/416	140/303	116/228	97/176	83/138	72/111	62/90	55/74	49/62
Triple	22	160/251	127/176	103/129	85/97	72/74	61/59				
	20	197/309	156/217	127/158	105/119	88/92	75/72	65/58			
	18	270/464	214/326	174/238	144/178	121/137	103/108	89/87	78/70	68/58	61/48

(Uniform Total Load, psf/Load Producing L/240 or 1", psf)											
Span Condition	Gage	Span									
		4'0"	4'6"	5'0"	5'6"	6'0"	6'6"	7'0"	7'6"	8'0"	8'6"
Single	22	222/133	175/94	142/68	117/51						
	20	269/164	213/115	172/84	142/63	120/49					
	18	364/246	288/173	233/126	193/95	162/73	138/57	119/46			
Double	22	204/321	161/226	131/164	108/124	91/95	78/75				
	20	250/395	198/278	161/202	133/152	112/117	96/92	82/74			
	18	344/593	272/416	221/303	183/228	154/176	131/138	113/111	99/90	87/74	77/62
Triple	22	253/251	201/176	163/129	135/97	114/74	97/59				
	20	311/309	247/217	201/158	166/119	140/92	119/72	103/58			
	18	428/464	339/326	275/238	228/178	192/137	164/108	141/87	123/70	108/58	96/48



LOAD TABLES

NS, NI, NSA, NIA Deck Uplift

Note:
Fy = 40 ksi

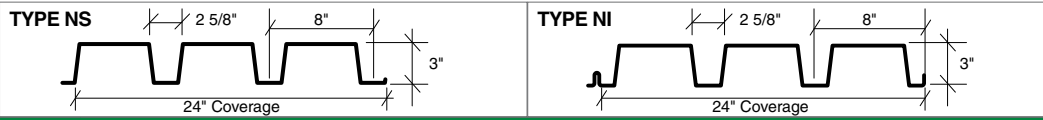

(Uniform Total Load, psf/Load Producing L/240 or 1", psf)												
Span Condition	Gage	Span										
		10'0"	10'6"	11'0"	11'6"	12'0"	12'6"	13'0"	13'6"	14'0"	14'6"	15'0"
Single	22	64/40	58/35	53/30	48/26							
	20	82/52	74/45	67/39	62/34	57/30	52/27	48/24				
	18	112/75	102/65	93/56	85/49	78/43	72/38	66/34	61/30	57/27	53/25	50/22
	16	144/102	131/88	119/77	109/67	100/59	92/52	85/47	79/42	73/37	68/34	64/30
Double	22	57/96	52/83	47/72	43/63	40/56	37/49	34/44	31/39			
	20	75/125	68/108	62/94	56/82	52/72	48/64	44/57	41/51	38/46	36/41	33/37
	18	103/180	94/156	85/135	78/118	72/104	66/92	61/82	57/73	53/66	49/59	46/53
	16	135/247	123/213	112/185	102/162	94/143	87/126	80/112	74/100	69/90	64/81	60/73
Triple	22	71/75	64/65	59/57	54/50	49/44	46/39	42/34	39/31			
	20	93/98	84/84	77/73	70/64	65/57	60/50	55/44	51/40	48/36	44/32	42/29
	18	129/141	117/122	107/106	98/93	90/82	83/72	76/64	71/57	66/51	62/46	58/42
	16	168/193	153/167	139/145	128/127	117/112	108/99	100/88	93/78	86/70	80/63	75/57



Areas marked with this symbol exceed SDI recommended maximum spans. (see database)

Areas marked with this symbol represent impractical spans.

J, JA Deck Uplift

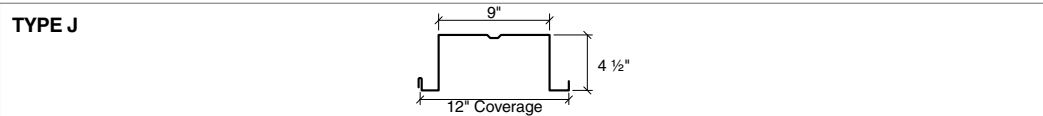

(Uniform Total Load, psf/Load Producing L/240 or 1", psf)												
Span Condition	Gage	Span										
		10'0"	11'0"	12'0"	13'0"	14'0"	15'0"	16'0"	17'0"	18'0"	19'0"	20'0"
Single	20	155/150	128/112	108/87	92/68	79/55	69/44	61/37	54/30	48/26	43/22	39/19
	19	187/183	155/138	130/106	111/83	96/67	83/54	73/45	65/37	58/31	52/27	47/23
	18	216/217	179/163	150/126	128/99	110/79	96/64	84/53	75/44	67/37	60/32	54/27
	16	274/290	226/218	190/168	162/132	140/106	122/86	107/71	95/59	84/50	76/42	68/36
Double	20	129/360	108/271	92/209	79/164	69/131	60/107	53/88	47/73	42/62	38/53	34/45
	19	166/441	139/331	117/255	101/201	87/161	76/131	67/108	60/90	53/76	48/64	43/55
	18	195/523	162/393	137/303	117/238	101/191	89/155	78/128	69/106	62/90	56/76	50/65
	16	255/699	212/525	179/404	153/318	132/255	115/207	101/171	90/142	80/120	72/102	65/87
Triple	20	156/282	131/212	112/163	96/128	84/103	74/84					
	19	203/345	170/259	144/200	124/157	108/126	94/102					
	18	239/409	199/308	169/237	145/186	126/149	110/121					
	16	315/547	262/411	221/316	189/249	164/199	143/162					



Web crippling is considered at gravity loads but is not considered a limit state during uplift. Fasteners must be designed separately for uplift and/or diaphragm shear.



Types H6, HA6, H7.5, HA7.5 LS4.5, LS6, LS7.5

 Note:
 F_y = 40 ksi

LONG SPAN ROOF DECK DATA BASE

ATTRIBUTE		TYPE H				TYPE LS 4.5				TYPE LS 6.0				TYPE LS 7.5			
		H6, HA6		H7.5, HA 7.5													
Note	Gage	18	16	18	16	16	14	12	10	16	14	12	10	16	14	12	10
	Thickness	.0474	.0598	.0474	.0598	.0598	.0747	.1046	.1345	.0598	.0747	.1046	.1345	.0598	.0747	.1046	.1345
	Weight, psf	4.3	5.5	4.8	6.1	4.9	6.1	8.6	11.0	5.5	6.9	9.6	12.4	6.1	7.7	10.7	13.8
1	I _p in. ⁴	6.69	8.76	11.21	14.70	4.84	6.06	8.45	10.82	9.45	11.87	16.55	21.19	15.94	20.04	27.94	35.77
1	I _n in. ⁴	7.41	9.43	12.11	15.56	4.86	6.06	8.45	10.82	9.52	11.87	16.55	21.19	16.08	20.04	27.94	35.77
1	S _p in. ³	1.97	2.61	2.65	3.54	1.94	2.46	3.44	4.38	2.85	3.70	5.18	6.60	3.85	5.07	7.10	9.04
1	S _n in. ³	2.05	2.67	2.64	3.47	2.00	2.49	3.44	4.38	3.00	3.74	5.18	6.60	4.11	5.11	7.10	9.04
2	R2 lbs.	760	1180	720	1130	1230	1860	3470	5540	1170	1780	3360	5390	1120	1720	3270	5260
3	R3 lbs.	860	1340	820	1280	1390	2090	3880	6150	1330	2010	3760	5980	1270	1940	3650	5840
4	R4 lbs.	950	1470	910	1410	1530	2290	4220	6660	1460	2200	4090	6480	1400	2130	3980	6330
5	R5 lbs.	1030	1580	980	1520	1650	2460	4520	7120	1570	2370	4380	6920	1510	2290	4260	6760
6	V, lbs.	3290	6630	2610	5260	6730	9330	12980	16570	6700	10500	17680	22620	5300	10350	20600	28670
7	Max. 1 span	25'9"	27'6"	29'3"	31'4"	23'9"	25'1"	27'3"	29'0"	28'1"	29'9"	32'3"	34'0"	32'0"	33'10"	34'0"	34'0"
8	Max. Cant.	9'4"	10'2"	10'10"	11'6"	8'0"	8'10"	9'9"	10'6"	10'1"	10'9"	11'10"	12'10"	11'9"	12'7"	13'0"	13'6"

Types H6, HA6, H7.5, HA7.5 LS4.5, LS6, LS7.5

LONG SPAN ROOF DECK DATA BASE

ATTRIBUTE		TYPE H				TYPE LS 4.5				TYPE LS 6.0				TYPE LS 7.5			
		H6, HA6		H7.5, HA 7.5													
Note	Gage	18	16	18	16	16	14	12	10	16	14	12	10	16	14	12	10
	Thickness	.0474	.0598	.0474	.0598	.0598	.0747	.1046	.1345	.0598	.0747	.1046	.1345	.0598	.0747	.1046	.1345
	Weight, psf	4.3	5.5	4.8	6.1	4.9	6.1	8.6	11.0	5.5	6.9	9.6	12.4	6.1	7.7	10.7	13.8
1	I _p in. ⁴	6.69	8.76	11.21	14.70	4.84	6.06	8.45	10.82	9.45	11.87	16.55	21.19	15.94	20.04	27.94	35.77
1	I _n in. ⁴	7.41	9.43	12.11	15.56	4.86	6.06	8.45	10.82	9.52	11.87	16.55	21.19	16.08	20.04	27.94	35.77
1	S _p in. ³	1.97	2.61	2.65	3.54	1.94	2.46	3.44	4.38	2.85	3.70	5.18	6.60	3.85	5.07	7.10	9.04
1	S _n in. ³	2.05	2.67	2.64	3.47	2.00	2.49	3.44	4.38	3.00	3.74	5.18	6.60	4.11	5.11	7.10	9.04
2	R2 lbs.	1160	1800	1110	1730	1880	2840	5310	8470	1790	2730	5140	8240	1720	2640	5000	8040
3	R3 lbs.	1320	2040	1260	1960	2120	3200	5930	9410	2030	3080	5750	9150	1950	2970	5590	8930
4	R4 lbs.	1460	2240	1390	2160	2330	3500	6460	10200	2230	3370	6260	9920	2140	3250	6080	9680
5	R5 lbs.	1570	2420	1500	2330	2520	3770	6920	10890	2410	3630	6710	10590	2310	3500	6520	10340
6	V, lbs.	5010	10080	3970	7990	10230	14190	19720	25180	10190	15970	26880	34380	8060	15740	31310	43580
7	Max. 1 span	25'9"	27'6"	29'3"	31'4"	23'9"	25'1"	27'3"	29'0"	28'1"	29'9"	32'3"	34'0"	32'0"	33'10"	34'0"	34'0"
8	Max. Cant.	9'4"	10'2"	10'10"	11'6"	8'0"	8'10"	9'9"	10'6"	10'1"	10'9"	11'10"	12'10"	11'9"	12'7"	13'0"	13'6"

LONG SPAN ROOF DECK DATABASE NOTES:

- I_p, I_n, S_p, and S_n are the section properties per foot of width. These values were calculated using the AISI Specifications. The subscripts denote positive or negative bending.
- Allowable end reaction per foot of deck width using 2" bearing for ASD and the factored nominal reaction for LRFD.
- Allowable end reaction per foot of deck width using 3" bearing for ASD and the factored nominal reaction for LRFD.
- Allowable end reaction per foot of deck width using 4" bearing for ASD and the factored nominal reaction for LRFD.
- Allowable end reaction per foot of deck width using 5" bearing for ASD and the factored nominal reaction for LRFD.
- Allowable vertical shear per foot of width and the factored nominal shear for LRFD. Do not confuse this with horizontal diaphragm shear strength. Table values of 2, 3, 4, 5 and 6 have been multiplied by the appropriate φ factor for the LRFD tables.
- Maximum recommended single span for roofs are based on SDI and OSHA criteria and production limits.
- Maximum recommended cantilever span based on SDI criteria. Values are sensitive to adjacent spans as they are controlled by deflection. For this table, adjacent spans are assumed to be at least 2 times greater than the cantilever span. Call if more precise calculation is needed.

GENERAL NOTES:

- All long span roof decks have interlocking side laps. Type HA means the decks are acoustic; acoustic LS is not available. Better side lap connections are obtained by screwing or welding through the flat side laps and this is the recommended type. Button punching often is specified for cosmetic concerns. The type LS side lap is concealed. Both sides of interlocking side lap must be fastened at supports.
- Information not provided on this chart may be obtained from Canam Engineering offices.

LONG SPAN DATABASE

Long Span Deck

Note:
Fy = 40 ksi

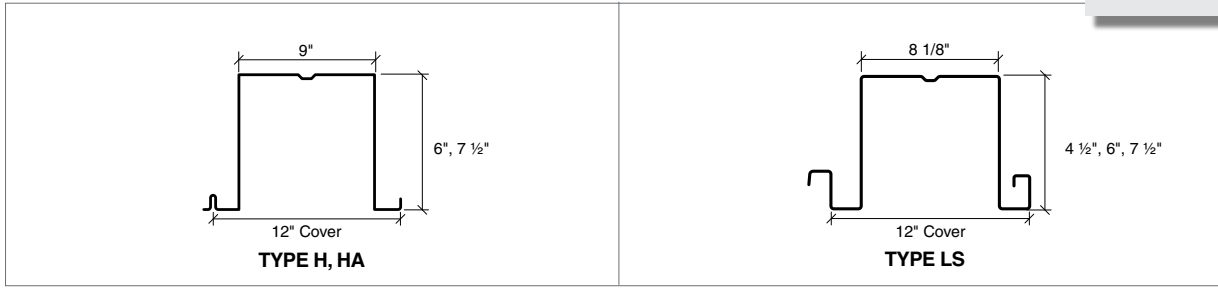

Types H6, HA6, H7.5 and HA7.5

		SINGLE SPAN CONDITION, (Total Load, psf/ Load Producing L/240 OR 1", psf)															
Type	Gage	18'0"	19'0"	20'0"	21'0"	22'0"	23'0"	24'0"	25'0"	26'0"	27'0"	28'0"	29'0"	30'0"	31'0"	32'0"	
H6	ASD	18	84/75	80/64	76/55	71/45	65/38	60/31	55/26	50/22	47/19						
		16	129/99	116/84	104/72	95/59	86/49	79/41	73/35	67/29	62/25	57/22	53/19	50/16	46/14	43/12	41/11
	LRFD	18	129/75	122/64	116/55	110/45	103/38	94/31	87/26	80/22	74/19						
		16	200/99	183/84	165/72	150/59	137/49	125/41	115/35	106/29	98/25	91/22	84/19	79/16	73/14	69/12	65/11
H7.5	ASD	18	80/126	76/107	72/92	69/76	65/63	63/53	60/44	58/38	55/32	53/28	51/24	50/21	47/18		
		16	126/166	119/141	113/121	108/99	103/82	98/69	94/58	90/49	84/42	78/36	72/31	67/27	63/24	59/21	55/18
	LRFD	18	123/126	117/107	111/92	106/76	101/63	97/53	93/44	89/38	85/32	82/28	79/24	77/21	74/18		
		16	192/166	182/141	173/121	165/99	157/82	150/69	144/58	138/49	133/42	123/36	114/31	107/27	100/24	93/21	88/18

Types LS4.5, LS6 and LS7.5

		SINGLE SPAN CONDITION, (Total Load, psf/ Load Producing L/240 OR 1", psf)																	
Type	Gage	18'0"	19'0"	20'0"	21'0"	22'0"	23'0"	24'0"	25'0"	26'0"	27'0"	28'0"	29'0"	30'0"	31'0"	32'0"	33'0"	34'0"	
LS4.5	ASD	16	96/54	86/46	78/40	70/33	64/27	59/23	54/19										
		14	121/68	109/58	98/50	89/41	81/34	74/28	68/24	63/20	58/17								
		12	170/95	152/81	138/69	125/57	114/47	104/40	96/33	88/28	81/24	76/21	70/18						
	LRFD	10	216/122	194/104	175/89	159/73	145/61	132/51	122/43	112/36	104/31	96/27	89/23	83/20					
		16	152/54	136/46	123/40	111/33	102/27	93/23	85/19										
		14	192/68	173/58	156/50	141/41	129/34	118/28	108/24	100/20	92/17								
LS6.0	ASD	12	269/95	241/81	218/69	198/57	180/47	165/40	151/33	139/28	129/24	120/21	111/18						
		10	342/122	307/104	277/89	252/73	229/61	210/51	193/43	178/36	164/31	152/27	142/23	132/20					
		16	130/106	123/90	114/78	103/64	94/53	86/44	79/37	73/32	67/27	63/23	58/20	54/18					
	LRFD	14	183/134	164/114	148/97	134/80	122/67	112/56	103/47	95/40	88/34	81/29	76/25	70/22	66/19				
		12	256/186	230/158	207/136	188/112	171/93	157/78	144/66	133/56	123/48	114/41	106/35	99/31	92/27	86/24	81/21	76/18	
		10	326/239	293/203	264/174	239/143	218/119	200/99	183/84	169/71	156/61	145/52	135/45	126/39	117/34	110/30	103/27	97/23	91/21
LS7.5	ASD	16	199/106	188/90	179/78	164/64	149/53	136/44	125/37	116/32	107/27	99/23	92/20	86/18					
		14	289/134	260/114	234/97	213/80	194/67	177/56	163/47	150/40	139/34	129/29	120/25	111/22	104/19				
		12	405/186	364/158	328/136	298/112	271/93	248/78	228/66	210/56	194/48	180/41	167/35	156/31	146/27	137/24	128/21	121/18	
	LRFD	10	516/239	463/203	418/174	379/143	345/119	316/99	290/84	268/71	247/61	229/52	213/45	199/39	186/34	174/30	163/27	154/23	145/21
		16	124/179	118/153	112/131	107/108	102/89	97/75	93/63	90/54	86/46	83/39	79/34	73/30	68/26	64/23	60/20		
		14	191/226	181/192	172/164	164/135	156/112	150/94	141/79	130/67	120/58	111/50	103/43	96/37	90/32	84/28	79/25	74/22	70/20
LRFD	12	351/315	315/267	284/229	258/189	235/157	215/131	197/111	182/94	168/80	156/69	145/60	135/52	126/45	118/40	111/35	104/31	98/27	
	10	446/403	401/342	362/294	328/242	299/201	273/168	251/142	231/120	214/103	198/88	184/76	172/66	161/58	151/51	141/45	133/40	125/35	
	16	191/179	181/153	172/131	164/108	156/89	150/75	143/63	138/54	132/46	127/39	123/34	116/30	108/26	101/23	95/20			
LRFD	14	293/226	278/192	264/164	251/135	240/112	230/94	220/79	206/67	190/58	176/50	164/43	153/37	143/32	134/28	125/25	118/22	111/20	
	12	555/315	498/267	450/229	408/189	372/157	340/131	312/111	288/94	266/80	247/69	229/60	214/52	200/45	187/40	176/35	165/31	156/27	
	10	707/403	634/342	573/294	519/242	473/201	433/168	398/142	366/120	339/103	314/88	292/76	272/66	254/58	238/51	224/45	210/40	198/35	

- Yellow shading indicates areas where web crippling controls.
- Areas marked with this symbol exceed SDI recommended maximum spans. (see database)

LONG SPAN LOAD TABLES

Long Span Deck

Note:
Fy = 40 ksi

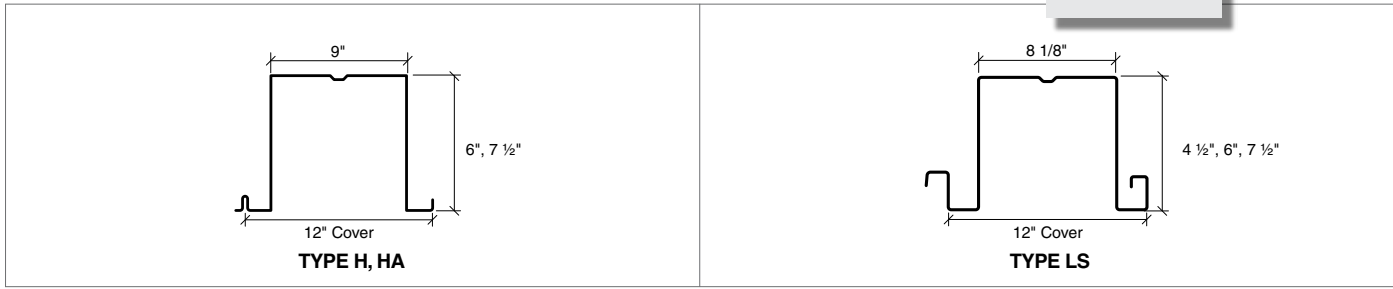

Types H6, HA6, H7.5 and HA7.5 Uplift

SINGLE SPAN CONDITION, Uniform Uplift Load, (psf), Controlled by Stress/ Load at Deflection = L/240 or 1"																			
Type	Gage	18'0"	19'0"	20'0"	21'0"	22'0"	23'0"	24' 0"	25'0"	26'0"	27'0"	28'0"	29'0"	30'0"	31'0"	32'0"	33'0"	34'0"	
H6	ASD	18	101/75	91/64	82/55	74/45	68/38	62/31	57/26	52/22	49/19	45/17	42/14	39/12	36/11	34/10	32/8	30/7	28/7
		16	132/99	118/84	107/72	97/59	88/49	81/41	74/35	68/29	63/25	59/22	54/19	51/16	47/14	44/12	42/11	39/10	37/9
	LRFD	18	160/75	144/64	130/55	118/45	107/38	98/31	90/26	83/22	77/19	71/17	66/14	62/12	58/11	54/10	51/8	48/7	45/7
		16	209/99	187/84	169/72	153/59	140/49	128/41	117/35	108/29	100/25	93/22	86/19	80/16	75/14	70/12	66/11	62/10	59/9
H7.5	ASD	18	130/126	117/107	106/92	96/76	87/63	80/53	73/44	68/38	62/32	58/28	54/24	50/21	47/18	44/16	41/14	39/12	37/11
		16	171/166	154/141	139/121	126/99	115/82	105/69	96/58	89/49	82/42	76/36	71/31	66/27	62/24	58/21	54/18	51/16	48/14
	LRFD	18	206/126	185/107	167/92	152/76	138/63	126/53	116/44	107/38	99/32	92/28	85/24	80/21	74/18	70/16	65/14	61/12	58/11
		16	271/166	244/141	220/121	199/99	182/82	166/69	153/58	141/49	130/42	121/36	112/31	105/27	98/24	91/21	86/18	81/16	76/14

Types LS4.5, LS6, and LS7.5 Uplift

SINGLE SPAN CONDITION, Uniform Uplift Load, (psf), Controlled by Stress/ Load at Deflection = L/240 or 1"																			
Type	Gage	18'0"	19'0"	20'0"	21'0"	22'0"	23'0"	24'0"	25'0"	26'0"	27'0"	28'0"	29'0"	30'0"	31'0"	32'0"	33'0"	34'0"	
LS4.5	ASD	16	99/54	89/46	80/40	73/33	66/27	60/23	56/19	51/16	47/14	44/12	41/10	38/9	36/8	33/7	31/6	29/5	28/5
		14	123/68	110/58	100/50	90/41	82/34	75/28	69/24	64/20	59/17	55/15	51/13	47/11	44/10	41/9	39/8	37/7	34/6
		12	170/95	152/81	138/69	125/57	114/47	104/40	96/33	88/28	81/24	76/21	70/18	65/16	61/14	57/12	54/11	51/9	48/8
	LRFD	10	216/122	194/104	175/89	159/73	145/61	132/51	122/43	112/36	104/31	96/27	89/23	83/20	78/18	73/15	68/14	64/12	61/11
		16	156/54	140/46	127/40	115/33	105/27	96/23	88/19	81/16	75/14	70/12	65/10	60/9	56/8	53/7	49/6	47/5	44/5
		14	195/68	175/58	158/50	143/41	130/34	119/28	110/24	101/20	93/17	87/15	80/13	75/11	70/10	66/9	62/8	58/7	55/6
LS6	ASD	10	342/122	307/104	277/89	252/73	229/61	210/51	193/43	178/36	164/31	152/27	142/23	132/20	123/18	115/15	108/14	102/12	96/11
		16	148/106	133/90	120/78	109/64	99/53	91/44	83/37	77/32	71/27	66/23	61/20	57/18	53/15	50/13	47/12	44/10	42/9
		14	185/134	166/114	150/97	136/80	124/67	113/56	104/47	96/40	89/34	82/29	76/25	71/22	66/19	62/17	58/15	55/13	52/12
	LRFD	12	256/186	230/158	207/136	188/112	171/93	157/78	144/66	133/56	123/48	114/41	106/35	99/31	92/27	86/24	81/21	76/18	72/16
		10	326/239	293/203	264/174	239/143	218/119	200/99	183/84	169/71	156/61	145/52	135/45	126/39	117/34	110/30	103/27	97/23	91/21
		16	235/106	211/90	190/78	172/64	157/53	144/44	132/37	122/32	112/27	104/23	97/20	90/18	84/15	79/13	74/12	70/10	66/9
LS7.5	ASD	14	292/134	262/114	237/97	215/80	196/67	179/56	164/47	152/40	140/34	130/29	121/25	113/22	105/19	99/17	93/15	87/13	82/12
		12	405/186	364/158	328/136	298/112	271/93	248/78	228/66	210/56	194/48	180/41	167/35	156/31	146/27	137/24	128/21	121/18	114/16
		10	516/239	463/203	418/174	379/143	345/119	316/99	290/84	268/71	247/61	229/52	213/45	199/39	186/34	174/30	163/27	154/23	145/21
	LRFD	16	203/179	182/153	164/131	149/108	136/89	124/75	114/63	105/54	97/46	90/39	84/34	78/30	73/26	68/23	64/20	60/18	57/16
		14	252/226	226/192	204/164	185/135	169/112	155/94	142/79	131/67	121/58	112/50	104/43	97/37	91/32	85/28	80/25	75/22	71/20
		10	446/403	401/342	362/294	328/242	299/201	273/168	251/142	231/120	214/103	198/88	184/76	172/66	161/58	151/51	141/45	133/40	125/35
LRFD	16	321/179	288/153	260/131	236/108	215/89	197/75	181/63	167/54	154/46	143/39	133/34	124/30	116/26	108/23	102/20	96/18	90/16	
	14	400/226	359/192	324/164	294/135	267/112	245/94	225/79	207/67	191/58	178/50	165/43	154/37	144/32	135/28	126/25	119/22	112/20	
	10	555/315	498/267	450/229	408/189	372/157	340/131	312/111	288/94	266/80	247/69	229/60	214/52	200/45	187/40	176/35	165/31	156/27	
		707/403	634/342	573/294	519/242	473/201	433/168	398/142	366/120	339/103	314/88	292/76	272/66	254/58	238/51	224/45	210/40	198/35	

Web crippling is considered at gravity loads but is not considered a limit state during uplift. Fasteners must be designed separately for uplift and/or diaphragm shear.

LONG SPAN LOAD TABLES



Note:
Fy = 33 ksi

Cellular Roof Deck Data Base

Product & Gage (T/B)	Wt (psf)	I _p (in ⁴)	I _n (in ⁴)	S _p (in ³)	S _n (in ³)	ASD			LRFD			Max. Single Span	Max. Multi Span	Max. Cant.	FM Span
						V (lbs)	R2 (lbs)	R4 (lbs)	V (lbs)	R2 (lbs)	R4 (lbs)				
Notes		1	1	1	1	6	2	4	6	2	4	7	8	9	10
BCS 20/20	3.5	0.38	0.30	0.30	0.31	1860	830	1350	2820	1270	2010	8'-9"	10'-4"	2'-2"	6'-6"
BCS 20/18	4.0	0.41	0.38	0.31	0.39	1860	830	1350	2820	1270	2010	9'-1"	10'-9"	2'-4"	6'-6"
BCS 18/20	4.5	0.52	0.38	0.45	0.40	2440	1390	2290	3710	2120	3410	10'-3"	12'-1"	2'-4"	7'-5"
BCS 18/18	5.0	0.56	0.45	0.46	0.47	2440	1390	2290	3710	2120	3410	10'-8"	12'-7"	2'-7"	7'-5"
BCS 18/16	5.5	0.60	0.65	0.47	0.55	2440	1390	2290	3710	2120	3410	11'-1"	13'-0"	3'-1"	7'-5"
BCS 16/18	5.5	0.71	0.54	0.64	0.56	3050	2120	3550	4640	3240	5270	12'-0"	14'-2"	2'-10"	9'-6"
BCS 16/16	6.0	0.77	0.70	0.65	0.68	3050	2120	3550	4640	3240	5270	12'-6"	14'-9"	3'-2"	9'-6"
NCS 20/20	4.5	1.45	1.28	0.60	0.71	3260	600	1200	4950	920	1780	16'-3"	17'-9"	4'-3"	12'-3"
NCS 20/18	5.0	1.58	1.51	0.60	0.86	3260	600	1200	4950	920	1780	16'-3"	19'-6"	4'-7"	12'-3"
NCS 18/20	5.0	1.97	1.62	0.88	0.88	4640	1020	2000	7050	1560	2980	19'-9"	19'-9"	4'-9"	14'-7"
NCS 18/18	5.5	2.13	1.87	0.90	1.04	4640	1020	2000	7050	1560	2980	20'-0"	21'-6"	5'-1"	14'-7"
NCS 18/16	6.0	2.28	2.30	0.91	1.28	4640	1020	2000	7050	1560	2980	20'-0"	23'-6"	5'-5"	14'-7"
NCS 16/18	6.5	2.74	2.23	1.24	1.22	5830	1560	3070	8850	2390	4560	22'-4"	23'-3"	5'-4"	16'-6"
NCS 16/16	7.0	2.94	2.63	1.26	1.46	5830	1560	3070	8850	2390	4560	22'-11"	25'-6"	5'-8"	16'-6"

Deep Cellular Roof Deck Data Base

Product & Gage (T/B)	Wt (psf)	I _p (in ⁴)	I _n (in ⁴)	S _p (in ³)	S _n (in ³)	ASD				LRFD				Max. Single Span	Max. Multi Span	Max. Cant.
						V (lbs)	R3 (lbs)	R5e (lbs)	R5i (lbs)	V (lbs)	R3 (lbs)	R5e (lbs)	R5i (lbs)			
Notes		1	1	1	1	6	3	5e	5i	6	3	5e	5i	7	8	9
JCS 20/20	4.0	3.86	3.12	1.02	1.14	2000	440	520	860	3040	670	800	1280	21'-3"	22'-3"	6'-4"
JCS 20/18	4.5	4.16	3.65	1.01	1.44	2000	440	520	860	3040	670	800	1280	21'-3"	25'-0"	6'-6"
JCS 18/20	5.0	4.95	3.92	1.51	1.38	3840	740	880	1440	5840	1130	1350	2140	26'-0"	24'-6"	6'-10"
JCS 18/18	5.5	5.41	4.50	1.54	1.69	3840	740	880	1440	5840	1130	1350	2140	26'-0"	7'-3"	7'-3"
JCS 18/16	6.0	5.81	5.18	1.54	2.07	3840	740	880	1440	5840	1130	1350	2140	26'-0"	7'-7"	7'-7"
JCS 16/18	6.0	6.74	5.41	2.07	1.96	6020	1140	1350	2190	9140	1740	2060	3260	30'-2"	7'-8"	7'-8"
JCS 16/16	6.5	7.27	6.13	2.10	2.35	6020	1140	1350	2190	9140	1740	2060	3260	30'-6"	7'-11"	7'-11"
HC6S 18/20	5.5	9.74	7.50	2.51	2.03	3400	700	840	1430	5170	1070	1280	2120	33'-6"	8'-11"	8'-11"
HC6S 18/18	6.5	10.77	8.53	2.48	2.45	3400	700	840	1430	5170	1070	1280	2120	33'-0"	9'-3"	9'-3"
HC6S 18/16	7.0	11.74	9.74	2.46	2.94	3400	700	840	1430	5170	1070	1280	2120	33'-0"	9'-8"	9'-8"
HC6S 16/18	7.5	13.20	10.27	3.47	2.85	6110	1080	1290	2180	9290	1660	1970	3240	34'-0"	9'-9"	9'-9"
HC6S 16/16	8.0	14.27	11.54	3.54	3.36	6110	1080	1290	2180	9290	1660	1970	3240	34'-0"	10'-1"	10'-1"
HC7.5S 18/20	5.5	16.27	12.63	3.15	2.59	2680	670	800	1420	4070	1020	1220	2110	34'-0"	10'-4"	10'-4"
HC7.5S 18/18	6.5	17.99	14.09	3.13	3.23	2680	670	800	1420	4070	1020	1220	2110	34'-0"	10'-8"	10'-8"
HC7.5S 18/16	7.0	18.95	15.95	3.11	3.90	2680	670	800	1420	4070	1020	1220	2110	34'-0"	11'-1"	11'-1"
HC7.5S 16/18	8.0	21.54	16.98	4.62	3.84	5390	1040	1240	2170	8190	1590	1890	3230	34'-0"	11'-3"	11'-3"
HC7.5S 16/16	8.0	23.34	18.95	4.65	4.48	5390	1040	1240	2170	8190	1590	1890	3230	34'-0"	11'-7"	11'-7"

See Production Limits.

CELLULAR DECK DATABASE NOTES:

- I_p, I_n, S_p, and S_n are the section properties per foot of width. These values were calculated using the AISI Specifications. The subscripts denote positive or negative bending.
- Allowable end reaction per foot of deck width with 2" bearing for ASD and the factored nominal reaction for LRFD.
- Allowable end reaction per foot of deck width with 3" bearing for ASD and the factored nominal reaction for LRFD.
- Allowable interior reaction per foot of deck width with 4" bearing for ASD and the factored nominal reaction for LRFD.
- Allowable end reaction per foot of deck width with 5" bearing for ASD and the factored nominal reaction for LRFD.
- Allowable interior reaction per foot of deck width with 5" bearing for ASD and the factored nominal reaction for LRFD.
- Allowable vertical shear per foot of width for ASD and the factored nominal shear for LRFD. Do not confuse this with horizontal diaphragm shear strength.
- Maximum recommended single span for roofs based on SDI and OSHA criteria and production limits.
- Maximum recommended multi span for roofs based on SDI and OSHA criteria and production limits. The maximum production limit for JC deck is 45' and for HC6 & HC7.5 it is 34'. Unequal multi span conditions are possible.
- Maximum recommended cantilever span based on SDI criteria. Values are sensitive to adjacent spans as they are controlled by deflection. For this table, adjacent spans are assumed to be at least 1.5 times greater than the cantilever span for long span deck and 2 times greater than the cantilever span for 1.5" and 3" cellular deck. Call if you need a more precise calculation.
- Maximum spans for Factory Mutual Class 1 construction. Refer to the FM Approval Guide and FM 1-29 for fastening requirements and span restrictions at perimeter. Note that the same FM spans are also applicable to acoustic cellular decks (BCAS & NCAS).

GENERAL NOTES:

- Cellular deck has flat side lap that allow screws or welds. Better side lap connections are obtained by screwing or welding through the flat side laps and this is the recommended type. Cosmetic concerns often required button punches. Fire ratings do not address cellular roof deck. Cellular products often are approved in floors.
- Stiffened liner panels are aesthetically pleasing and improve bottom side appearance by accenting lines and reducing visibility of spot welds. Designers should expect visible spot welds. Flat panel (stiffened rib not rolled in) is available on special request.
- Light gage cellular deck subjected to high concentrated loads may require additional spot welds to resist shear forces in the deck.
- Information not provided on this chart may be obtained from Canam Engineering offices.

The tables on pages 14, 15, and 16 show the uniform loads for roof applications. If the deck is to be used with the flat side up, such as may be used on a mezzanine floor, ask for tables based on floor loading for the deck inverted; the side lap is modified for inverted applications.

CELLULAR DATABASE

Types BCS, BCAS

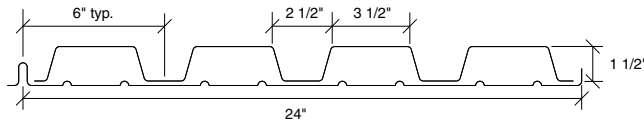

Note:
Fy = 33 ksi

(Total Load, psf / Load Producing L/240 or 1", psf)														
Span Type	Gage	Span												
		6'0"	6'6"	7'0"	7'6"	8'0"	8'6"	9'0"	9'6"	10'0"	10'6"	11'0"	11'6"	12'0"
SINGLE	20/20	111/116	95/91	82/73	71/59	63/49	55/41	49/34	44/29	40/25	36/22	33/19	30/16	28/14
	20/18	115/125	98/98	84/78	73/64	65/53	57/44	51/37	46/31	41/27	37/23	34/20	31/18	29/16
	18/20	167/158	142/124	122/100	107/81	94/67	83/56	74/47	66/40	60/34	54/29	50/26	45/22	42/20
	18/18	170/170	145/134	125/107	109/87	96/72	85/60	76/50	68/43	61/37	56/32	51/28	46/24	43/21
	18/16	174/182	148/143	128/115	111/93	98/77	87/64	77/54	69/46	63/39	57/34	52/30	47/26	44/23
	16/18	237/216	202/170	174/136	152/111	133/91	118/76	105/64	95/54	85/47	77/40	71/35	65/31	59/27
DOUBLE	16/16	241/234	205/184	177/147	154/120	135/99	120/82	107/69	96/59	87/51	79/44	72/38	66/33	60/29
	20/20	112/278	96/219	83/175	72/142	64/117	56/98	50/82	45/70	41/60	37/52	34/45	31/39	29/35
	20/18	139/300	119/236	103/189	90/154	79/127	70/106	63/89	57/76	51/65	47/56	42/49	39/43	36/38
	18/20	144/381	124/299	107/240	93/195	82/161	73/134	65/113	58/96	53/82	48/71	44/62	40/54	37/48
	18/18	168/410	144/322	125/258	109/210	96/173	85/144	76/121	68/103	62/89	56/76	51/67	47/58	43/51
	18/16	194/439	167/345	145/277	126/225	112/185	99/154	89/130	80/111	72/95	65/82	60/71	55/62	50/55
TRIPLE	16/16	201/520	172/409	149/327	130/266	115/219	102/183	91/154	82/131	74/112	67/97	61/84	56/74	51/65
	20/20	138/218	118/171	103/137	90/111	79/92	70/77	63/64	56/55	51/47	46/41	42/35	39/31	36/27
	20/18	170/235	146/185	127/148	111/120	98/99	87/83	78/70	70/59	64/51	58/44	53/38	48/33	44/29
	18/20	179/298	153/234	132/188	116/152	102/126	91/105	81/88	73/75	66/64	60/56	54/48	50/42	46/37
	18/18	207/321	178/252	154/202	135/164	119/135	106/113	95/95	85/81	77/69	70/60	64/52	58/46	54/40
	18/16	238/344	205/270	178/216	156/176	138/145	123/121	110/102	99/87	89/74	81/64	74/56	68/49	63/43
16/18	248/407	213/320	184/256	161/208	142/172	126/143	113/120	102/102	92/88	83/76	76/66	70/58	64/51	
16/16	295/441	254/347	220/278	193/226	171/186	152/155	136/131	122/111	111/95	101/82	92/72	84/63	77/55	



(Total Load, psf / Load Producing L/240 or 1", psf)														
Span Type	Gage	Span												
		6'0"	6'6"	7'0"	7'6"	8'0"	8'6"	9'0"	9'6"	10'0"	10'6"	11'0"	11'6"	12'0"
SINGLE	20/20	174/116	148/91	128/73	111/59	98/49	87/41	77/34	69/29	63/25	57/22	52/19	47/16	44/14
	20/18	180/125	153/98	132/78	115/64	101/53	90/44	80/37	72/31	65/27	59/23	54/20	49/18	45/16
	18/20	261/158	223/124	192/100	167/81	147/67	130/56	116/47	104/40	94/34	85/29	78/26	71/22	65/20
	18/18	267/170	228/134	196/107	171/87	150/72	133/60	119/50	107/43	96/37	87/32	79/28	73/24	67/21
	18/16	273/182	232/143	200/115	175/93	153/77	136/64	121/54	109/46	98/39	89/34	81/30	74/26	68/23
	16/18	372/216	317/170	273/136	238/111	209/91	185/76	165/64	148/54	134/47	121/40	111/35	101/31	93/27
16/16	377/234	322/184	277/147	242/120	212/99	188/82	168/69	151/59	136/51	123/44	112/38	103/33	94/29	
DOUBLE	20/20	175/278	150/219	130/175	113/142	100/117	88/98	79/82	71/70	64/60	58/52	53/45	49/39	45/35
	20/18	217/300	186/236	161/189	141/154	124/127	110/106	99/89	89/76	80/65	73/56	66/49	61/43	56/38
	18/20	226/381	193/299	167/240	146/195	129/161	114/134	102/113	92/96	83/82	75/71	69/62	63/54	58/48
	18/18	263/410	225/322	195/258	171/210	150/173	133/144	119/121	107/103	97/89	88/76	80/67	74/58	68/51
	18/16	304/439	261/345	226/277	198/225	175/185	155/154	139/130	125/111	113/95	103/82	94/71	86/62	79/55
	16/18	314/520	269/409	233/327	204/266	179/219	159/183	142/154	128/131	116/112	105/97	96/84	88/74	81/65
16/16	376/563	323/443	280/355	245/289	216/238	192/198	172/167	154/142	140/122	127/105	116/91	106/80	97/70	
TRIPLE	20/20	216/218	185/171	160/137	140/111	124/92	110/77	98/64	88/55	80/47	72/41	66/35	61/31	56/27
	20/18	266/235	229/185	199/148	174/120	154/99	137/83	122/70	110/59	100/51	91/44	83/38	76/33	70/29
	18/20	279/298	239/234	207/188	181/152	160/126	142/105	127/88	114/75	103/64	94/56	85/48	78/42	72/37
	18/18	324/321	278/252	241/202	211/164	186/135	165/113	148/95	133/81	120/69	109/60	100/52	91/46	84/40
	18/16	372/344	320/270	278/216	244/176	216/145	192/121	172/102	155/87	140/74	127/64	116/56	106/49	98/43
	16/18	388/407	332/320	288/256	252/208	222/172	198/143	177/120	159/102	144/88	131/76	119/66	109/58	100/51
16/16	461/441	396/347	344/278	302/226	267/186	237/155	213/131	191/111	173/95	157/82	144/72	132/63	121/55	



Presently the North American Specification (NAS) does not apply to "as manufactured" cellular deck. The method to determine cellular deck negative section properties is under study and the resultant method might appear in the first supplement to the 2007 edition of the NAS. This catalog maintains the previous 33 ksi section properties based on SDI research. The published load tables use Fy 33 ksi. The shear values and web crippling resistance conform to the NAS 2007 edition. The material is ordered as Fy 40 ksi. It is acceptable to neglect the bottom plate and to use the published value of the 40 ksi top element.

Because of production limitations and long spans, the tables for JCS, HC6S & HC7.5S are single span. HC6S & HC7.5S have production limits of 34 feet. NCS and JCS are limited to 40 feet. Multispans are possible but resultant lengths might be either impractical for shipping or job site handling or impossible due to production limits. The BCS & NCS tables include multispans conditions. The BCS & NCS tables are based on equal spans and uniform loads plus 4 inch bearing at interior supports. The long span uniform load tables use 3 inch exterior bearing. Preliminary selection can be done for unequal spans. Based on the longer span, use the lesser of the two span or three span values when spans are within 20%. Analysis is recommended for other cases or when the longest span is interior. Additional fasteners might be required to resist prying at short exterior spans.

CELLULAR LOAD TABLES

Types NCS, NCAS

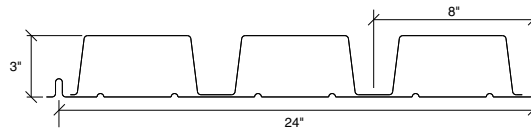

Note:
F_y = 33 ksi

(Total Load, psf / Load Producing L/240 or 1", psf)														
Span Type	Gage	Span												
		10'0"	10'6"	11'0"	11'6"	12'0"	12'6"	13'0"	13'6"	14'0"	14'6"	15'0"	15'6"	16'0"
SINGLE	20/20	80/95	73/82	66/72	60/63	56/55	51/49	47/43	44/39	41/35	38/31	36/28	33/26	31/23
	20/18	80/104	73/90	66/78	60/68	56/60	51/53	47/47	44/42	41/38	38/34	36/31	33/28	31/25
	18/20	117/129	106/112	97/97	89/85	81/75	75/66	69/59	64/53	60/47	56/42	52/38	49/35	46/32
	18/18	120/140	109/121	99/105	91/92	83/81	77/72	71/64	66/57	61/51	57/46	53/41	50/38	47/34
	18/16	121/150	110/129	100/112	92/98	84/87	78/77	72/68	67/61	62/55	58/49	54/44	51/40	47/37
	16/18	165/180	150/155	137/135	125/118	115/104	106/92	98/82	91/73	84/66	79/59	73/53	69/48	65/44
DOUBLE	16/16	168/193	152/167	139/145	127/127	117/112	108/99	99/88	92/78	86/70	80/63	75/57	70/52	66/47
	20/20	93/229	85/198	77/172	71/151	65/133	60/117	55/104	51/93	48/84	45/75	42/68	39/62	37/56
	20/18	96/250	91/216	87/188	83/164	78/145	72/128	67/114	62/102	58/91	54/82	50/74	47/67	44/61
	18/20	116/311	105/269	96/234	88/205	81/180	75/159	69/142	64/127	59/113	55/102	52/92	49/84	46/76
	18/18	136/337	124/291	113/253	103/221	95/195	88/172	81/153	75/137	70/123	65/110	61/100	57/90	54/82
	18/16	160/360	151/311	138/271	127/237	116/209	107/185	99/164	92/146	86/131	80/118	75/107	70/97	66/88
TRIPLE	16/18	160/433	146/374	133/325	122/285	112/251	103/222	95/197	89/176	82/158	77/142	72/128	67/116	63/106
	16/16	191/465	173/401	158/349	145/306	133/269	123/238	114/212	106/189	98/169	92/152	86/138	80/125	75/113
	20/20	109/179	104/155	96/135	88/118	81/104	75/92	69/82	64/73	60/65	56/59	52/53	49/48	46/44
	20/18	109/195	104/169	99/147	95/129	91/113	87/100	83/89	77/79	72/71	67/64	63/58	59/52	55/48
	18/20	144/244	131/211	119/183	109/160	101/141	93/125	86/111	80/99	74/89	69/80	65/72	61/65	57/59
	18/18	169/263	154/228	140/198	129/173	118/152	109/135	101/120	94/107	87/96	81/86	76/78	71/71	67/64



(Total Load, psf / Load Producing L/240 or 1", psf)														
Span Type	Gage	Span												
		10'0"	10'6"	11'0"	11'6"	12'0"	12'6"	13'0"	13'6"	14'0"	14'6"	15'0"	15'6"	16'0"
SINGLE	20/20	125/95	114/82	104/72	95/63	87/55	80/49	74/43	69/39	64/35	60/31	56/28	52/26	49/23
	20/18	125/104	114/90	104/78	95/68	87/60	80/53	74/47	69/42	64/38	60/34	56/31	52/28	49/25
	18/20	184/129	167/112	152/97	139/85	128/75	118/66	109/59	101/53	94/47	87/42	82/38	77/35	72/32
	18/18	188/140	171/121	155/105	142/92	131/81	120/72	111/64	103/57	96/51	89/46	84/41	78/38	73/34
	18/16	190/150	173/129	157/112	144/98	132/87	122/77	113/68	104/61	97/55	90/49	85/44	79/40	74/37
	16/18	259/180	235/155	214/135	196/118	180/104	166/92	153/82	142/73	132/66	123/59	115/53	108/48	101/44
DOUBLE	16/16	263/193	239/167	218/145	199/127	183/112	169/99	156/88	144/78	134/70	125/63	117/57	110/52	103/47
	20/20	142/229	133/198	121/172	111/151	102/133	94/117	87/104	81/93	75/84	70/75	65/68	61/62	58/56
	20/18	142/250	136/216	129/188	124/164	119/145	113/128	105/114	97/102	91/91	84/82	79/74	74/67	70/61
	18/20	182/311	165/269	150/234	138/205	127/180	117/159	108/142	100/127	93/113	87/102	81/92	76/84	71/76
	18/18	213/337	194/291	177/253	162/221	149/195	137/172	127/153	118/137	110/123	102/110	96/100	90/90	84/82
	18/16	238/360	227/311	216/271	198/237	182/209	168/185	156/164	145/146	135/131	126/118	117/107	110/97	103/88
TRIPLE	16/18	251/433	228/374	208/325	190/285	175/251	162/222	149/197	139/176	129/158	120/142	113/128	105/116	99/106
	16/16	298/465	271/401	247/349	227/306	209/269	192/238	178/212	165/189	154/169	144/152	134/138	126/125	118/113
	20/20	162/179	154/155	147/135	138/118	127/104	117/92	108/82	100/73	93/65	87/59	82/53	76/48	72/44
	20/18	162/195	154/169	147/147	141/129	135/113	125/100	116/89	108/79	100/71	93/64	87/58	82/52	77/48
	18/20	226/244	205/211	187/183	171/160	158/141	145/125	135/111	125/99	116/89	108/80	101/72	95/65	89/59
	18/18	265/263	241/228	220/198	201/173	185/152	171/135	158/120	147/107	137/96	128/86	119/78	112/71	105/64



Yellow indicates areas where web crippling controls.

CELLULAR LOAD TABLES

Note:
Fy = 33 ksi

Type JCS, HC6S and HC7.5S

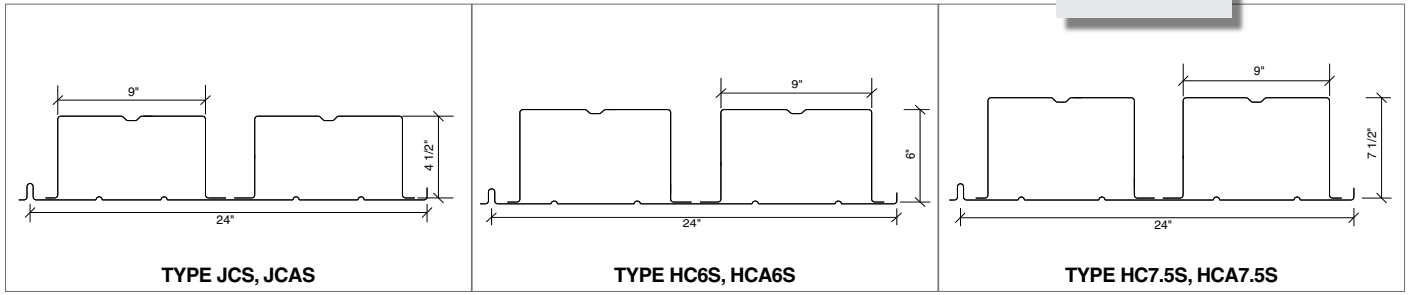

ASD	JCS, JCAS DECK	Span Type	Gage	(Total Load, psf / Load Producing L/240 or 1", psf)															
				Span															
				8'0"	9'0"	10'0"	11'0"	12'0"	13'0"	14'0"	15'0"	16'0"	17'0"	18'0"	19'0"	20'0"	21'0"	22'0"	23'0"
SINGLE	20/20	110/495	98/348	88/253	80/190	73/147	68/115	63/92	59/75	53/62	47/52	42/43	38/37	34/32	31/26	28/22	26/18	24/15	
SINGLE	20/18	110/533	98/375	88/273	80/205	73/158	68/124	63/100	59/81	53/67	47/56	42/47	37/40	34/34	31/28	28/23	25/20	23/16	
SINGLE	18/20	185/635	164/446	148/325	135/244	123/188	114/148	103/118	89/96	79/79	70/66	62/56	56/47	50/41	46/33	42/28	38/23	35/20	
SINGLE	18/18	185/694	164/487	148/355	135/267	123/206	114/162	105/129	91/105	80/87	71/72	63/61	57/52	51/44	47/37	42/30	39/25	36/21	
SINGLE	18/16	185/745	164/523	148/381	135/287	123/221	114/174	105/139	91/113	80/93	71/78	63/65	57/56	51/48	47/39	42/33	39/27	36/23	
SINGLE	16/18	285/864	253/607	228/443	207/332	190/256	163/201	141/161	123/131	108/108	96/90	85/76	76/65	69/55	63/46	57/38	52/32	48/27	
SINGLE	16/16	285/932	253/655	228/477	207/359	190/276	166/217	143/174	124/141	109/117	97/97	86/82	78/70	70/60	63/49	58/41	53/34	49/29	

LRFD	JCS, JCAS DECK	Span Type	Gage	(Total Load, psf / Load Producing L/240 or 1", psf)															
				Span															
				8'0"	9'0"	10'0"	11'0"	12'0"	13'0"	14'0"	15'0"	16'0"	17'0"	18'0"	19'0"	20'0"	21'0"	22'0"	23'0"
SINGLE	20/20	168/495	149/348	134/253	122/190	112/147	103/115	96/92	89/75	83/62	74/52	66/43	59/37	53/32	48/26	44/22	40/18	37/15	
SINGLE	20/18	168/533	149/375	134/273	122/205	112/158	103/124	96/100	89/81	82/67	73/56	65/47	58/40	53/34	48/28	44/23	40/20	37/16	
SINGLE	18/20	283/635	251/446	226/325	205/244	188/188	174/148	161/118	140/96	123/79	109/66	97/56	87/47	79/41	72/33	65/28	60/23	55/20	
SINGLE	18/18	283/694	251/487	226/355	205/267	188/206	174/162	161/129	143/105	126/87	111/72	99/61	89/52	80/44	73/37	67/30	61/25	56/21	
SINGLE	18/16	283/745	251/523	226/381	205/287	188/221	174/174	161/139	143/113	126/93	111/78	99/65	89/56	80/48	73/39	67/33	61/27	56/23	
SINGLE	16/18	435/864	387/607	348/443	316/332	290/256	256/201	221/161	192/131	169/108	150/90	134/76	120/65	108/55	98/46	89/38	82/32	75/27	
SINGLE	16/16	435/932	387/655	348/477	316/359	290/276	260/217	224/174	195/141	171/117	152/97	135/82	122/70	110/60	100/49	91/41	83/34	76/29	

ASD	HC6S DECK	Span Type	Gage	(Total Load, psf / Load Producing L/240 or 1", psf)															
				Span															
				18'0"	19'0"	20'0"	21'0"	22'0"	23'0"	24'0"	25'0"	26'0"	27'0"	28'0"	29'0"	30'0"	31'0"	32'0"	33'0"
SINGLE	18/20	78/110	74/93	70/80	67/66	64/55	61/46	58/39	54/33	50/28	46/24	43/21	40/18	37/16	35/14	33/12	31/11	29/10	
SINGLE	18/18	78/121	74/103	70/88	67/73	64/60	61/51	57/43	53/36	49/31	45/27	42/23	39/20	37/17	34/15	32/13	30/12	29/11	
SINGLE	18/16	78/132	74/112	70/96	67/79	64/66	61/55	57/46	52/39	49/34	45/29	42/25	39/22	36/19	34/17	32/15	30/13	28/12	
SINGLE	16/18	120/149	114/126	108/108	103/89	96/74	87/62	80/52	74/44	68/38	63/33	59/28	55/25	51/21	48/19	45/17	42/15	40/13	
SINGLE	16/16	120/161	114/137	108/117	103/96	98/80	89/67	82/56	76/48	70/41	65/35	60/30	56/26	52/23	49/20	46/18	43/16	41/14	
SINGLE	18/20	119/110	113/93	107/80	102/66	97/55	93/46	89/39	84/33	78/28	72/24	67/21	62/18	58/16	55/14	51/12	48/11	45/10	
SINGLE	18/18	119/121	113,103	107/88	102/73	97/60	93/51	89/43	83/36	77/31	71/27	66/23	62/20	58/17	54/15	51/13	48/12	45/11	
SINGLE	18/16	119/132	113/112	107/96	102/79	97/66	93/55	89/46	82/39	76/34	71/29	66/25	61/22	57/19	54/17	50/15	47/13	44/12	
SINGLE	16/18	184/149	175/126	166/108	158/89	150/74	137/62	126/52	116/44	107/38	99/33	93/28	86/25	81/21	75/19	71/17	67/15	63/13	
SINGLE	16/16	184/161	175/137	166/117	158/96	151/80	140/67	128/56	118/48	109/41	101/35	94/30	88/26	82/23	77/20	72/18	68/16	64/14	
SINGLE	18/20	74/183	71/156	67/134	64/110	61/91	58/76	56/64	54/55	52/47	50/40	48/35	46/30	45/26	43/23	41/20	39/18	36/16	
SINGLE	18/18	74/203	71/172	67/148	64/121	61/101	58/84	56/71	54/60	52/52	50/44	48/38	46/33	45/29	43/26	41/23	38/20	36/18	
SINGLE	18/16	74/213	71/181	67/156	64/128	61/106	58/89	56/75	54/64	52/54	50/47	48/40	46/35	45/31	43/27	40/24	38/21	36/19	
SINGLE	16/18	116/243	109/206	104/177	99/145	95/121	90/101	87/85	83/72	80/62	77/53	74/46	72/40	68/35	64/31	60/27	57/24	53/21	
SINGLE	16/16	116/263	109/223	104/192	99/158	95/131	90/110	87/92	83/78	80/67	77/58	74/50	72/43	69/38	65/33	61/29	57/26	54/23	
SINGLE	18/20	113/183	107/156	102/134	97/110	93/91	89/76	85/64	82/55	78/47	76/40	73/35	70/30	68/26	66/23	64/20	60/18	57/16	
SINGLE	18/18	113/203	107/172	102/148	97/121	93/101	89/84	85/71	82/60	78/52	76/44	73/38	70/33	68/29	66/26	64/23	60/20	57/18	
SINGLE	18/16	113/213	107/181	102/156	97/128	93/106	89/89	85/75	82/64	78/54	76/47	73/40	70/35	68/31	66/27	63/24	60/21	56/19	
SINGLE	16/18	177/243	167/206	159/177	151/145	145/121	138/101	133/85	127/72	122/62	118/53	114/46	110/40	106/35	100/31	94/27	89/24	84/21	
SINGLE	16/16	177/263	167/223	159/192	151/158	145/131	138/110	133/92	127/78	122/67	118/58	114/50	110/43	106/38	101/33	95/29	89/26	84/23	

Note: HCA6S and HCA7.5S are available and the same load tables apply.

Yellow indicates areas where web crippling controls.

CELLULAR LOAD TABLES

Acoustic Roof Deck

BA, BIA, NSA, NIA, JA, HA6, and HA7.5 have perforated webs with acoustic batts that fit into the ribs as shown in the NSA image below. **BCAS, NCAS, JCAS, HCA6S, and HCA7.5S** are cellular deck units with acoustic batts shop-placed inside the cell - the bottom plates are perforated. Acoustic batts in non cellular deck are furnished by Canam, but installation of the batts is by others - usually the roofer.

Most erection of roof deck is not scheduled so that the roofing is immediately installed. Some exposure to the weather is to be expected, so galvanized deck is suggested as the finish for acoustic deck. Galvanizing keeps rust staining from developing, and therefore provides a better underside appearance. Field painting of galvanized deck is easily accomplished with paints formulated for this use. **Do not specify acoustic deck where fire proofing is required.**

For applications where a flat acoustically treated surface is needed, BCAS, NCAS, JCAS, HCA6S or HCA7.5S decks are applicable. These decks are made from galvanized steel and the minimum gages are 20 over 20. (The gages are designated by showing the top hat/bottom plate; e.g. 20/18 means the top hat section is 20 gage and the bottom plate is 18.) Weld marks (from resistance welding) show on the bottom plate. The tables on pages 14 through 16 show the uniform loads for roof applications.

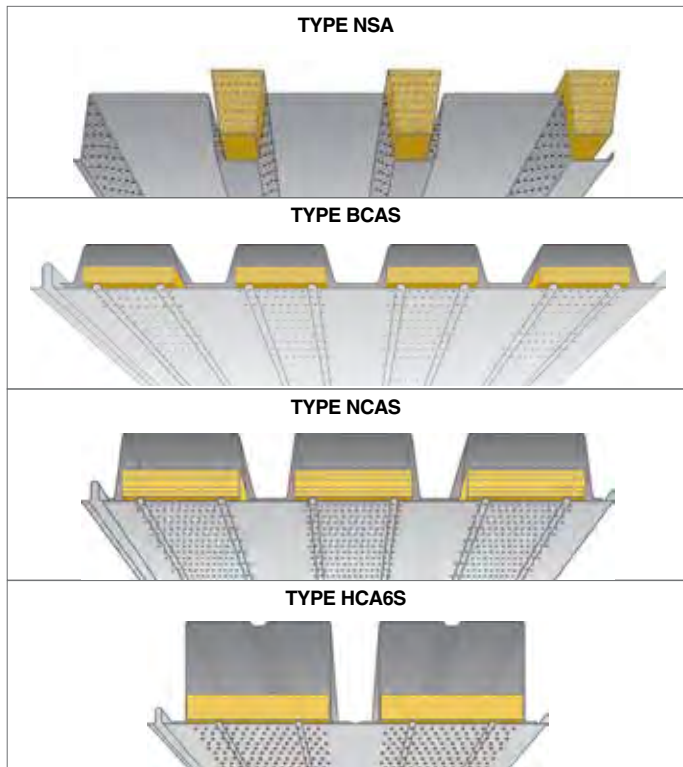

General Acoustic Information

Panel Type	Sound Absorption Data Frequency/Coefficient						Noise Red. Coef..
	125	250	500	1000	2000	4000	
BA, BIA (see p. 6)	0.10	0.18	0.57	1.00	0.60	0.34	0.60
NSA, NIA (see p. 7)	0.24	0.41	0.90	0.90	0.64	0.45	0.70
JA (see p. 7)	0.32	0.61	0.99	0.66	0.47	0.28	0.70
HA6 (see p. 11)	0.34	0.78	0.90	0.60	0.49	0.37	0.70
HA7.5 (see p. 11)	0.53	0.91	0.84	0.61	0.54	0.46	0.75
BCAS (see p. 14)	0.33	0.39	0.64	0.92	0.87	0.62	0.70
NCAS (see p. 15)	0.40	0.54	1.11	1.06	0.88	0.72	0.90
JCAS (see p. 16)	0.51	0.93	1.16	1.02	0.94	0.83	1.00
HCA6S (see p. 16)	0.56	1.09	1.11	0.97	0.90	0.73	1.00
HCA7.5S (see p. 16)	0.79	1.18	1.11	0.83	0.91	0.76	1.00

Testing by Riverbanks Acoustical Laboratories.

The Noise Reduction Coefficients (NRC) shown in the table are the average of the Sound Absorption Values for the 250, 500, 1000 and 2000 Hertz frequencies. The average is rounded to the nearest 0.05. Because of measurement method, the sound absorption number for a particular frequency can be greater than 1; for any specific use at that frequency the coefficient used should be 1.

The NRC is a measure of the amount of noise energy absorbed by a surface and is averaged over commonly occurring frequencies. Deck variables that can affect NRC are hole size plus pattern and insulation density. The NRC values furnished by these acoustic decks compare favorably with the NRC values supplied by acoustic ceiling tiles. The listed absorption can be used to an advantage if a predominant noise source has a particular frequency. For instance, if a machine room noise is known to be 2000 Hertz, BCAS would be a significantly better choice over BA even though the NRC for BCAS is closer to BA - 0.70 compared to 0.60. The noise absorption coefficient for BA at 1000 Hertz is better than BCAS.

NRC's should not be confused with Sound Transmission Coefficients (STC). STC's measure the blocking of sound by a barrier and relates to the decibel drop. Acoustic deck may not be a good choice if a high STC is needed. As an example, consider again the machine room. If the noise from the machine room is to be kept from going through the ceiling, then acoustic deck would be no better than conventional deck and may be worse because of the holes. However, if workers inside the machine room are to enjoy a quieter environment, then acoustic deck would be the proper choice.

Acoustic design depends on many factors in addition to listed NRC values. Firms specializing in this field should be consulted for many applications.

The table values were determined by Riverbank Acoustical Laboratories. NRC is a system measurement. These tests were performed with 2" Polyisocyanurate insulation board. These values are less than previous catalog editions and represent today's common construction practice. The older edition used 2" rigid fiberglass, which was common in the past.

ACOUSTIC DECK

Roof Deck Design Example Problem

THE NOMINAL ROOF SNOW LOAD (S) FOR A BUILDING HAS BEEN DETERMINED TO BE 35 psf. 20 psf IS TO BE INCLUDED AS A CONSIDERATION OF MAINTENANCE LOAD FROM WORKERS (L_r). THE DEAD LOAD (D) IS 10 psf. A WIND UPLIFT LOAD (W) IS 30 psf. RAIN SURCHARGE IS NOT REQUIRED. ANY LATERAL EARTHQUAKE LOAD WOULD BE CONSIDERED IN THE DIAPHRAGM DESIGN. FOR FLEXURE, (E) = 0. THE DECK IS IN A THREE (OR MORE) SPAN CONDITION AND THE SPAN IS 6'-6". LOAD COMBINATIONS GIVEN APPLY TO THIS EXAMPLE. SEE ASCE 07-05 OR GOVERNING CODE FOR ALL OTHER NOMINAL LOADS.

Load Combinations On This Roof



1. 1.4D
2. 1.2D + 1.6L + 0.5(L_r or S)
3. 1.2D + 1.6(L_r or S) + (0.5*L or 0.8W)
4. 1.2D + 1.6W + 0.5*L + 0.5(L_r or S)
5. 1.2D + 1.0E + 0.5*L + 0.2S
6. 0.9D + 1.6W
7. 0.9D + 1.0E



1. D
2. D + L
3. D + (L_r or S)
4. D + .75L + .75(L_r or S)
5. D + (W or 0.7E)
6. D + .75(W or 0.7E) + .75L + .75(L_r or S)
7. .6D + W
8. .6D + .7E

Load Definitions

- D = dead load
 E = earthquake load
 L = live load due to occupancy
 L_r = roof live load
 S = snow load
 W = wind load

* The 0.5 multiplier is acceptable for this occupancy per exception Note 1 of ASCE 07-05, section 2.3.2.

LRFD

The governing load combinations are 3 and 6, (1.2D + 1.6S + 0.5L) where L=0, and (0.9D + 1.6W), which total **68 psf and -39 psf** respectively. The deflection load is S = **35 psf**. The B deck LRFD load tables show that three span 22 gage deck can carry a factored gravity load or an uplift load of 140 psf based on stress and 72 psf based on a live load deflection of span/240. **140>68 O.K.; 72>35 O.K.; -140>-39 O.K.; -72>-30 for simplicity O.K.**

ASD

The governing load combinations are 3 and 7, D + (L_r or S) and (.6D + W), which total **45 psf** (for stress) and **-24 psf** respectively. The B deck ASD load table shows that three span 22 gage B deck can carry a gravity load or an uplift load of 88 psf based on stress and 72 psf based on a live load deflection of span/240. **88>45 O.K.; 72>35 O.K.; -88>-24 O.K.; -72>-24 O.K.**

Note the deflection values are exactly the same for both ASD and LRFD. The gage choice is the same regardless of the analysis used. Fasteners must be designed for uplift and/or diaphragm shear. Final check: Maximum multi span limits is 6'9" which is O.K. If FM class 1 construction is required, then the maximum span is 6'0" and 20 gage deck would be required.

Uplift Load Example Problem

The uplift resistance U, in psf, can be calculated for a given fastener pattern by the equation:

$$U = \frac{kP}{CL}$$

Where P is obtained from the chart of tensile strength of arc spot (puddle) welds for the listed gage and weld size. (k) is the equivalent number of connectors from the table below, C is the deck cover width and L is the deck span measured at center lines. (k) defines the weighted resistance of welds across the cover width. It is acceptable to include a reaction coefficient in the denominator, e.g. (1.1) for a multi-span condition.

A 22 gage 1 1/2" deep deck is fastened with a 36/4 pattern (12" o.c.). The deck span is 6'-6". Calculate the resisting uplift using ASD for 5/8" (0.625) diameter welds and for #12 screws with a head diameter of 0.430. Supports are joists, so pull out is not a concern.

WELDS:

From the Tensile Strength of Arc Spot (Puddle) Welds for A653 SS40 (galvanized) Chart (see page 20), P=1460 lbs., C = 3 feet; k = 2.7 (k reflects prying reduction at side lap.)

Interior support

$$U_n = \frac{2.7 (1460)}{3 \times 6.5} = 202 \text{ psf}$$

Note: End prying factor of 2 is applied at all exterior supports and is critical for single span. The same end prying factor of 2 may be used for screws.

Exterior support

$$U_n = \frac{2.7 (1460)}{3 (6.5/2) 2} = 202 \text{ psf}$$

Safety Factor $\Omega_u = 2.5$

$$U = 202/2.5 = 80.86 \approx 81 \text{ psf} > 24 \text{ psf (includes allowance for DL)}$$

SCREWS:

From Wind Uplift Values for Screws, pull over nominal value @ 22 gage base deck material with screw head d_w = 0.430 is (see page 19):

$$P = 990 \text{ lbs.}$$

$$U_n = \frac{3.0 (990)}{3 \times 6.5} = 152.31 \text{ psf}$$

Note: See uplift tables for flexural limits. If the roof deck resists diaphragm shear due to wind, the interaction of uplift and shear at support fasteners reduces diaphragm shear resistance. See the interaction design tool on the Canam website.

(k reflects no required prying reduction at side laps.)

Safety Factor $\Omega_u = 3.0$

$$U = 152.31/3 = 50.77 \approx 51 \text{ psf} > 24 \text{ psf}$$

	Weld Pattern	C	Welds (k)	Screws (k)
24/4		2	2.7	3
30/3		2.5	1.7	2
30/4		2.5	2.7	3
30/6		2.5	4.7	5
36/4		3	2.7	3
36/5		3	3.7	4
36/7		3	5.7	6

EXAMPLE PROBLEMS

Wind Uplift Values for Screws

DECK TO STRUCTURAL STEEL, OPEN WEB STEEL JOISTS, GAGE FRAMING

Pull Out Nominal Strengths, P_{not} , Lbs.

Screw pull out from structural steel framing or from steel joists rarely controls. Pull out is a definite possibility when light gage framing is used. The table shows pull out values for A653 steel (galvanized) with 40, 50 and 80 ksi yields. The tensile strength, $F_u = 62$ ksi, is used for determining nominal strength of Grade 80 steel per AISI section A2.3.2. **The lesser of pull out and pull over controls connection design.**

$$P_{not} = 0.85 t_2 d F_{u2} \quad t_2 \text{ (steel thickness receiving the screw point \& engaging the threads)} \quad F_{u2} = \text{tensile strength on that material}$$

Screw	Size(d)	F_u	Grade	1/4"	3/16"	10	1/8"	12	14	16	18	20	22	24	26	28					
				0.2500	0.1875	0.1345	0.1250	0.1046	0.0747	0.0598	0.0474	0.0358	0.0295	0.0239	0.0179	0.0149					
#10	0.190	55	40	X					664	531	421	318	262								
#10	0.190	65	50						784	628	498	376	310								
#10	0.190	62	80						748	599	475	358	295	239	179	149					
#12	0.216	55	40	2525	1893	1358	1262	1056	754	604	479	362	298								
#12	0.216	65	50	2896	2238	1605	1492	1248	891	714	566	427	352								
#12	0.216	62	80	2846	2134	1531	1423	1191	850	681	540	408	336	272	204	170					
1/4"	0.250	55	40	2922	2191	1572	1461	1223	873	699	554	418	345								
1/4"	0.250	65	50	3453	2590	1858	1727	1445	1032	826	655	494	407								
1/4"	0.250	62	80	3294	2470	1772	1647	1378	984	788	624	472	389	315	236	196					

Table uses the SDI decimal thickness for gage. Note that actual support frame, t_2 , gage thickness may differ from the SDI thickness. The safety factor for pull out (ASD) is 3. The ϕ factor (LRFD) is 0.5. Consult screw manufacturer for proper thread and drill point types at each support thickness. Threads must engage full thickness for table to apply. Shaded area equals 80% of screw breaking strength to avoid brittle failure. #10 screws not recommended for steel thickness in crossed out areas. F_u and F_y for hot rolled shapes will vary from this table. Linear interpolation for F_u is acceptable - see page 160.

Pull Over Nominal Values, P_{nov} , Lbs.

Pull over strength generally controls the uplift values of screws. The roof deck range is 16 to 22; the form deck typical gages are 24, 26, 28. Form deck is typically high strength (SS Grade 80) and uses $F_u = 62$ ksi in design.

$$P_{nov} = 1.5 t_1 d_w F_u \quad d_w \leq .5" \quad t_1 \text{ (steel thickness contacting screw head)}$$

d_w	Gage						
	16	18	20	22	24	26	28
0.400	1870	1480	1120	920	890	670	550
0.415	1940	1530	1160	960	920	690	580
0.430	2010	1590	1200	990	960	720	600
0.480	2240	1780	1340	1100	1070	800	670
0.500	2330	1850	1400	1150	1110	830	690

The table pullover strengths lbs., are based on $F_u = 52$ ksi (A1008 steel) for 16 through 22 gage, and 62 ksi for 24 through 28 gage. The safety factor for pull over is 3. The ϕ factor (LRFD) is 0.5. If A653 (galvanizing) is provided, the designer may linearly prorate the capacity using the F_u listed in the Pull Out table.

Screw Breaking Nominal Strength, Kips.

Breaking values are obtained from screw manufacturer. This table contains representative numbers.

Screw Data				
Screw Size	d (dia.)	d_w (nom. head dia.)	Avg. tested tensile strength	
10	0.190	0.415 or 0.400	2.56	
12	0.216	0.430 or 0.400	3.62	
1/4"	0.250	0.480 or 0.520	4.81	

Typical Screw Types

Self Drilling, Self Tapping	Diam. - threads per inch - screw length	Drill Point	Usage
	#10 - 16 x 3/4"	Type 1	Side lap
	#12 - 14 x 3/4"	Type 3	Side lap
	#12 - 24 x 7/8"	Type 4	SUPPORTS drilling and fastening metal up to 5/16" thick
	#12 - 24 x 1 1/4"	Type 5	drilling and fastening metal up to 1/2" thick

SCREWS

Tensile Strength of Arc Spot (Puddle) Welds

$$P_n = 0.8 (F_u / F_y)^2 \times t (d - t) \times F_u$$

The weld tensile strengths, in pounds, shown in the table cover the range of properties and thickness for roof deck. Weld washers are recommended for thickness less than 22 gage. The AISI's **North American Specification For The Design Of Cold-Formed Steel Structural Members** 2007 is the basis of the table. The strengths are the nominal (ultimate) values. For LRFD apply a ϕ factor of 0.60, and for ASD use a safety factor, Ω , of 2.5. Isolated (non repetitive) applications require $\phi = 0.50$, and $\Omega = 3.0$. Follow AWS D1.3 procedures for arc puddle welding. A minimum electrode strength of 60 ksi is required. The clear distance between the weld edges and the end of the deck must be greater than or equal to the weld visible diameter. Follow the local codes for design loads, load combinations, and load factors. If no code exists, use ASCE 7.

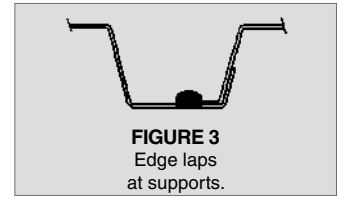
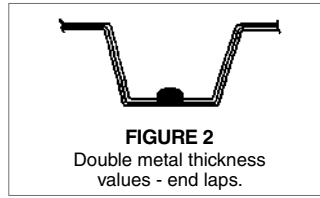
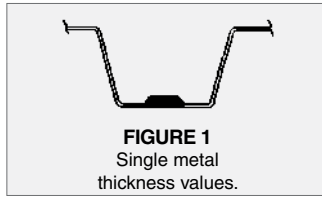

Steel	Gage	Visible Weld Diameter (inches)											
		Figure 1				Figure 2				Figure 3			
		0.5	0.625	0.75	1	0.5	0.625	0.75	1	0.5	0.625	0.75	1
A653 Grade 40 Fy = 40 ksi Fu = 55 ksi	22	1150	1460	1770	2380	2160	2780	3390	4540	810	1020	1240	1670
	20	1380	1750	2130	2870	2550	3300	4040	4540	970	1230	1490	2010
	18	1780	2280	2770	3760	2030	4110	4540	4540	1250	1590	1940	2630
	16	2190	2810	3430	4540	1370	3140	4540	4540	1530	1970	2400	3180
A1008 Grade 40 Fy = 40 ksi Fu = 52 ksi	22	980	1240	1490	2010	1830	2350	2870	3900	680	860	1050	1410
	20	1170	1480	1800	2430	2160	2790	3410	4060	820	1040	1260	1700
	18	1510	1920	2340	3170	2030	3530	4060	4060	1060	1350	1640	2220
	16	1850	2380	2900	3950	1370	3140	4060	4060	1300	1660	2030	2770
A653 Grade 50 Fy = 50 ksi Fu = 65 ksi	22	1220	1540	1870	2520	2290	2930	3580	4060	850	1080	1310	1760
	20	1460	1850	2250	3030	2700	3480	4060	4060	1020	1300	1570	2120
	18	1890	2410	2930	3970	2030	4060	4060	4060	1320	1680	2050	2780
	16	2310	2970	3630	4060	1370	3140	4060	4060	1620	2080	2540	2840
Grade 80 Fy = 60 ksi Fu = 62 ksi	22	740	930	1130	1520	1380	1770	2160	2560	510	650	790	1060
	20	880	1120	1350	1830	1620	2100	2560	2560	620	780	950	1280
	18	1140	1450	1760	2390	2030	2560	2560	2560	800	1020	1230	1670
	16	1390	1790	2190	2560	1370	2560	2560	2560	980	1250	1530	1790

Tensile Strength of Arc Spot (Puddle) Welds Through Weld Washers

Weld washer table values are based on the AISI Specification and use $F_y = 33$ ksi and $F_u = 48$ ksi for resistance limits through the 16 gage washer. Washers have 3/8" holes. The table is based on Structural Steel Grade 80 deck and considers pullover of the deck around the washer. The edge lap value is based on (Figure 3 or 3B) and applies a 0.7 prying factor to the lesser of the single or double sheet resistance. The table waives the minimum weld effective diameter of 3/8" at supports. LRFD values are Factored Nominal and ASD values are allowable resistance. LRFD table strength already includes the controlling ϕ factor. Limit states for weld washers in tension have variance in ϕ and Ω factors. This is why the controlling factored resistance is shown. The weld shear strength, pounds, is based on the value presented in the SDI Diaphragm Design Manual 3rd Ed. When welds are used as part of a diaphragm, the system ϕ and Ω factors will apply.

	Gage	Visible Weld Diameter (inches)					
		Figure 1		Figure 2		Figure 3, 3B	
		0.5	0.625	0.5	0.625	0.5	0.625
LRFD	28	1529	1529	1314	2338	920	1070
	26	1541	1837	1207	2446	845	1286
	24	1424	2209	1006	2155	704	1509
ASD	28	1006	1006	876	1559	613	704
	26	1027	1208	805	1630	563	846
	24	950	1472	670	1437	469	1006

Factored Nominal Tensile Strength of Welds Through 16 Gage Weld Washers - LRFD

Allowable Tensile Strength of Welds Through 16 Gage Weld Washers - ASD.

Shear Strength of Welds Through 16 Gage Weld Washers		
Gage	Factored LRFD $\phi : 0.60$	Allowable ASD $\Omega : 2.65$
28	679	427
26	873	549
24	1319	829

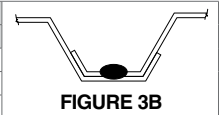

Shear Strength of Arc Spot (Puddle) Welds

See the diaphragm tables for the nominal shear strength of welds, Q_n , or consult Section E2.2 of the AISI Specifications. If shear is caused by diaphragm action use the system factors shown in the diaphragm tables. Otherwise consult the AISI Specifications for the appropriate safety and resistance factors.

WELDS

Curved Roof Deck

Shop curving (strong direction) of 1.5" B and 3" NS Roof Deck profiles is available. Please consult Canam Engineering for curving limitations. Cover and minimum radius depends on the curving process - crimp vs. no-crimp. For the no crimp case, the cover is nominally 24" and the minimum radius is 24' for 1.5" B deck. Field bending of roof deck in the strong direction is normally possible when a minimum concentrated load of 75 lbs/ft is applied over the support and the deck sheet contours to the required radius.

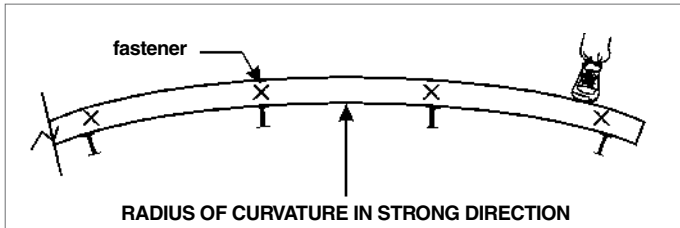

B, BI, NS, NI, F, J, H and LS non cellular fluted decks can readily be field curved in the weak direction.

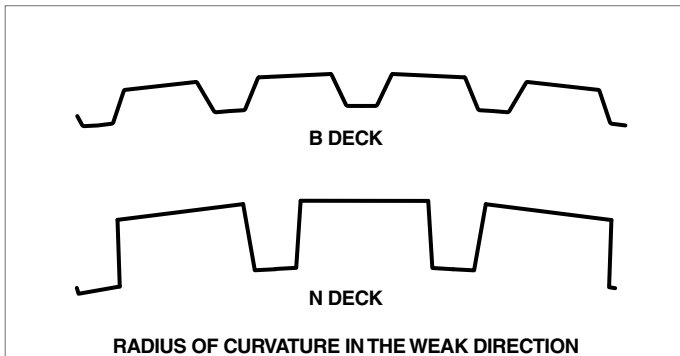

When radii are less than table values, shop curving is required. Spans that exceed the recommended maximum are left blank. The tables limit the maximum instantaneous stress in the deck to $0.8 F_y$ and the maximum residual stress to $0.6 F_y$. Residual moment is defined as: $M = EI/R$. For quick selection of gravity load capacity, treat as a flat roof. Residuals will be additive over supports and offset load stresses at midspan. A recommended sum is $0.66 F_y$.

When field curving deck, fasten every corrugation at the ends of the sheets to resist spring back. Detail butt end conditions to ease installation (no end laps). Screws are easier than welds at the supports because their self tapping nature grabs and pulls the deck down securely.

Cellular Deck cannot be shop curved in the strong direction but can be field curved in the weak direction - single radius "barrel vault" curvature. Double curvature that produces torsion and warping is not recommended. Because of the torsional stiffness of standard cellular deck, special weld patterns are used to ease resistance to single curvature weak axis bending and a minimum radius of 12 feet is possible. Longitudinal rows of welds can be removed at interior ribs, and the strength and stiffness then default to the top deck capacity. When cellular deck is field curved, avoid excessively long spans to minimize spring back at midspan.

Field Bending Guidelines

STRONG DIRECTION

B Deck

Gage	Smallest Support Spacing				
	4'0"	5'0"	6'0"	7'0"	8'0"
22	185/12.6	148/15.7	123/18.9		
20	237/10.0	189/12.5	158/15.0	135/17.5	
18	308/7.5	246/9.4	206/11.2	176/13.1	154/15.0
16	389/5.8	313/7.3	260/8.8	223/10.2	195/11.7

Minimum Radius of Curvature (ft.) / Residual Stress (ksi)

N Deck

Gage	Smallest Support Spacing				
	9'0"	10'0"	11'0"	12'0"	13'0"
22	373/13.5	336/15.0	306/16.5	280/18.0	259/19.5
20	464/10.6	418/11.8	380/12.9	348/14.1	322/15.3
18	615/7.7	553/8.6	503/9.4	461/10.3	426/11.1
16	775/6.0	697/6.7	633/7.3	581/8.0	536/8.7

Minimum Radius of Curvature (ft.) / Residual Stress (ksi)

Roof Deck Penetrations

The Steel Deck Institute states, "Openings not shown on the erection drawings, such as those required for stacks, conduits, plumbing, vents, etc. are to be cut, and reinforced if necessary, by the trades requiring the openings." Plates are only provided when specified on contract drawings. For 1.5" roof deck the following guide may be appropriate:

One rib removed from a panel and the hole is less than 6" in diameter and not more than two webs are removed - no reinforcing required (FIGURE A). A hole less than 8" in diameter requires a 0.045" plate (FIGURE B). One 8" to 13" (per panel) diameter hole - minimum 0.057" plate (Figure C).

Over 13" hole or a cluster of closely spaced holes of any diameter - either structural framing without plates or reinforcing zeos plus plates are specified and designed by the project engineer. (Figure D) This guide is not to be used as a replacement for the judgement or requirements of the design engineer or architect. Other considerations that have an effect are: 1) the location of the hole in the deck panel, 2) the ability of the deck to cantilever, 3) the expected loads.

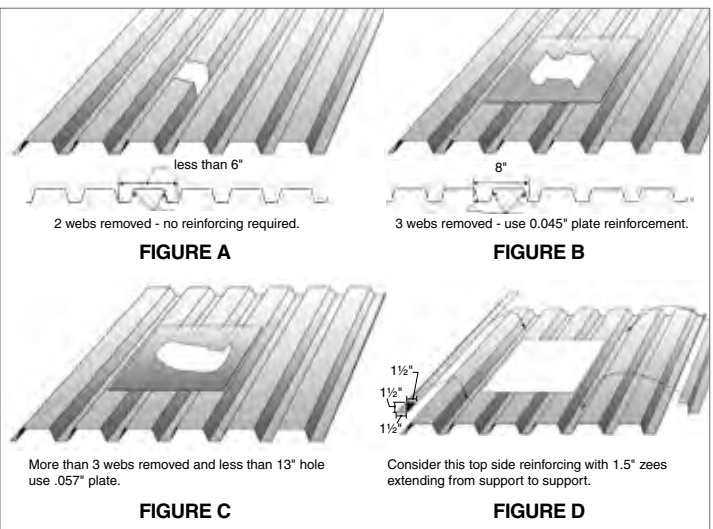

CURVED DECK

Typical Roof Details and Accessories

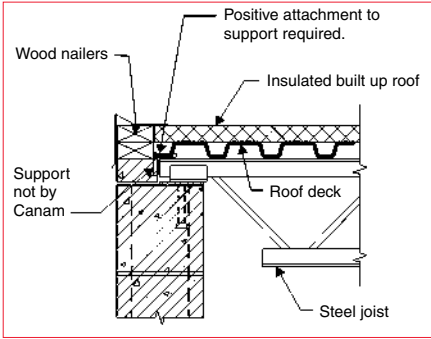

FLUSH EAVE

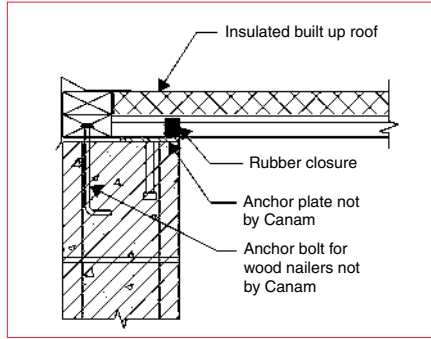

FLUSH EAVE

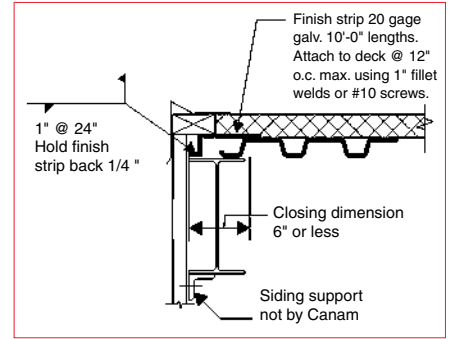

FLUSH EAVE

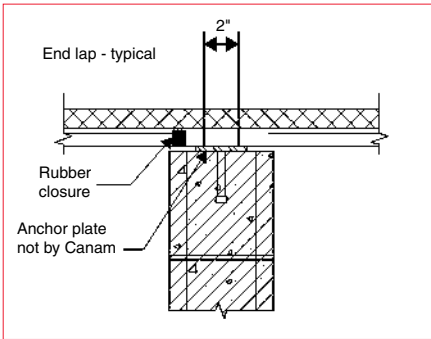

INTERIOR WALL

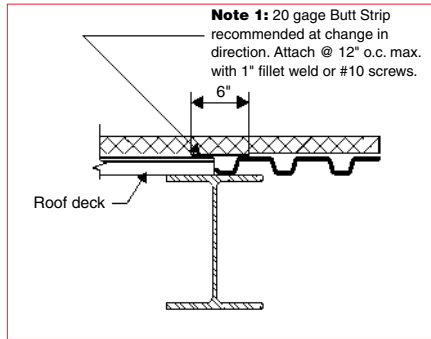

DETAIL WHERE DECK CHANGES DIRECTION

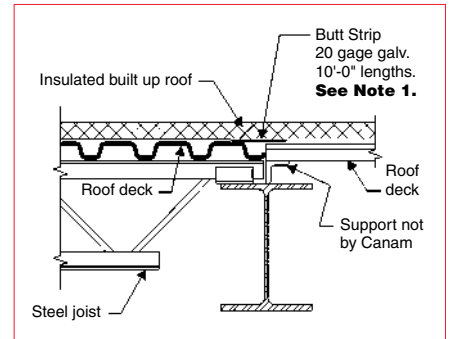

DETAIL WHERE DECK CHANGES DIRECTION

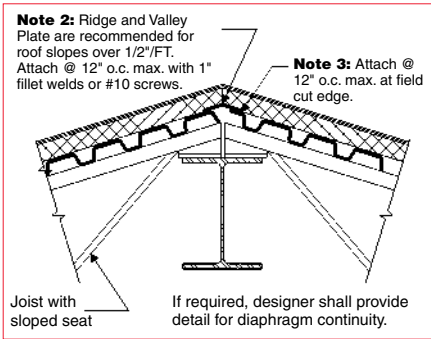

RIDGE DETAIL

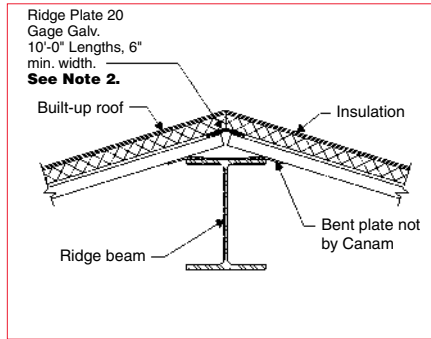

RIDGE DETAIL

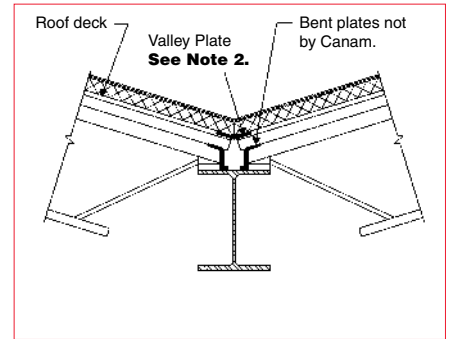

VALLEY DETAIL

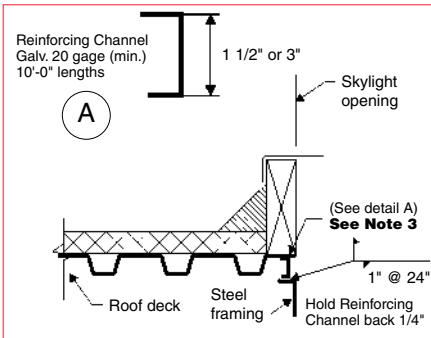

REINFORCING CHANNEL

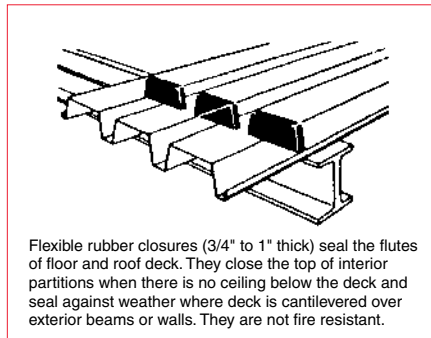

RUBBER CLOSURES

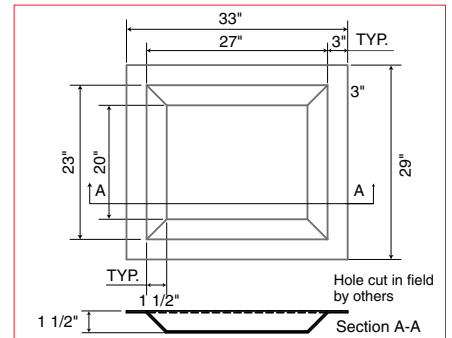

RECESSED SUMP PAN LEVEL (14 GAGE)

Minimum bearing on deck for all accessories shall be 2". Butt strips, Ridge and Valley Plates, Reinforcing Channels, Rubber Closures and Sump Pumps are furnished ONLY when ordered by the purchaser and/or specifically shown on the contract documents. When furnished the Level Sump Pan is the standard.

DETAILS



Roof Construction Fire Ratings

U.L Design	Hours	U.L Design	Hours
P201	1	P543	2
P202	1	P546	1
P203	¾	⊗ P701	¾, 1, 1½, 2
P204	1	P709	1, 1½, 2
P206	1	P710	1
P210	1	⊗ P711	1, 1½, 2
P211	1	P712	1, 1½, 2, 3
P214	1	P713	1, 1½, 2, 3
P215	2	P714	1, 1½, 2
P216	1	⊗ P717	1, 1½, 2
P219	2	P718	2
P225	1, 1½	⊗ P719	1, 1½, 2, 3
P227	1, 1½	P720	2
P230	1, 1½	P721	1
P231	1, 1½	P722	1, 1½, 2, 3
P235	1	⊗ P723	1, 1½, 2, 3
P237	2	P725	1, 1½, 2
P238	1	P726	1, 1½, 2
P241	2	P727	1, 1½, 2, 3
P246	1	P728	1½, 2
P250	1, 1½	P729	2
P251	1, 1½, 2	P730	1, 1½, 2, 3
P254	1	P731	1, 1½, 2, 3
P255	1	⊗ P732	1, 1½, 2, 3
P257	1	P733	1, 1½, 2, 3
P259	1, 1½	P734	1, 1½, 2
P261	1	P735	1
P264	1	P736	1, 1½, 2
P266	1½, 2	P738	1, 1½, 2
P267	1	P739	1, 1½, 2
P269	1, 1½	P740	1, 1½, 2
P301	1, 1½, 2	⊗ P741	1, 1½, 2
P303	1	P742	1, 1½, 2
P404	1½, 2	P743	1, 1½, 2
P405	3	⊗ P801	1, 1½, 2
P407	2	P811	1, 1½, 2, 3
P409	2	P815	1, 1½, 2
P410	2	⊗ P816	1, 1½, 2
P411	2	⊗ P819	1, 1½, 2
P503	2	P824	1
P508	1	P825	1, 1½, 2
P509	1	P826	1, 1½, 2, 3
P510	1, 1½	P827	1, 1½, 2
P511	1	P828	1, 1½, 2
P512	1	P901	1, 1½, 2
P513	1½	P902	1, 1½, 2
P514	1, 2	P903	1
P515	1	P907	1, 1½, 2
P518	1	P908	1, 1½, 2
P519	1, 2	P919	1, 1½
P520	2	P920	1, 1½, 2
P521	1, 1½, 2	P921	1, 1½, 2
P525	1, 1½, 2	P922	1, 1½, 2
P526	1, 1½	P923	1, 1½, 2
P527	1, 1½	P925	1, 1½, 2
P528	1	P926	1, 1½, 2
P529	1, 1½	P927	1, 1½, 2
P532	1, 1½, 2	P928	1, 1½, 2
P536	1, 1½, 2	P929	1, 1½, 2
P540	1	P930	1, 1½, 2
P541	1	P936	1, 1½, 2
P542	1	P937	1, 1½, 2

Roof - ceiling fire rated assemblies listed in the Underwriters Laboratory, Inc. Fire Resistance Directory, follow this numbering code: P2xx have suspended acoustical ceilings with an exposed grid system; P3xx have mineral or fiber board applied to the underside of the deck; P4xx have suspended gypsum board; P7xx and P8xx have **spray applied fire resistive material (SFRM)** applied to the steel deck; P9xx assemblies have no SFRM applied to the deck although it is still required on the beams or the joists. The P9xx ratings (with steel deck) in the directory are all with insulating concrete. Individual designs in each of the categories can have a variety of insulation systems: insulating boards of various materials, vermiculite or perlite or cellular concrete, foamed plastic, and combinations of these. Some designs in the P2xx, P4xx, P5xx, and P9xx series allow galvanized form type products but not fluted roof deck. Roof deck may be painted or galvanized when used in designs that include suspended ceilings (Designs P2xx, P4xx, P5xx and P9xx). **Please note that the deck is only one component of the fire rated assembly. Be sure to check the U.L. Fire Resistance Directory for all details of construction.**

All of the designs describe the steel deck in generic terms. Some show, in addition to the general description, a list of classified products. Canam or United Steel Deck, Inc. is specifically listed in some assemblies but, even if not specifically named, Canam can meet the general requirements with one or more of our deck products and therefore can supply the required deck component for the assembly.

It is also important to note that U.L. will allow the substitution of heavier (thicker), deeper and stronger members than shown in the assembly requirements. However the designer should review the details of the assembly to check span limits, spacing considerations, and connection requirements. When U.L. calls for the use of welding washers, the washers can be eliminated for deck that is 22 gage or thicker.

Galvanized deck should be used for constructions that require the use of sprayed-on fire protection material. Designs marked with an (⊗) allow the use of classified painted roof deck with SFRM. Designers must note in the roof deck project specification that spray proofing is required over painted deck. Do not specify acoustic deck where SFRM is required. **Canam is not responsible for the adhesive ability of any SFRM, or for any treatment, cleaning, or preparation of the deck surface required for the adhesion of SFRM.** Consult the SFRM manufacturer for application directions and limitations.

This listing is based on the Underwriters Laboratories Fire Resistance Directory, 2007 Edition

FIRE RATINGS

ANSI/SDI-RD1.0 Standard for Steel Roof Deck

1. General

1.1 Scope:

- A. This Specification for Steel Roof Deck shall govern the materials, design, and erection of cold formed steel deck used for the support of roofing materials, design live loads and SDI construction loads.
- B. Commentary shall not be considered part of the mandatory document.

1.2 Reference Codes, Standards and Documents:

- A. Codes and Standards: For purposes of this Standard, comply with applicable provisions of the following Codes and Standards:
1. American Iron and Steel Institute (AISI) Standard - *North American Specification for the Design of Cold-Formed Steel Structural Members*, 2001 Edition with Supplement 2004
 2. American Welding Society - ANSI/AWS D1.3 Structural Welding Code/Sheet Steel - 98 Structural Welding Code - Sheet Steel
 3. American Society for Testing and Materials (ASTM) A653 (A653M)-06, A924 (A924M)-06, A1008 (A1008M)-06
 4. American Society of Civil Engineering (ASCE) – SEI/ASCE7-05
 5. Underwriters Laboratories (UL) Fire Resistance Directory - <http://www.ul.com/database> 2006

- B. Reference Documents: Refer to the following documents:
1. SDI Manual of Construction with Steel Deck - MOC2-2006
 2. SDI Standard Practice Details - SPD2-2001
 3. SDI Position Statement - Field Painting of Steel Deck-2004
 4. SDI Diaphragm Design Manual - DDM03-2004

2. Products

2.1 Material:

- A. Sheet steel for galvanized deck shall conform to ASTM A653 (A653M) Structural Quality, with a minimum yield strength of 33 ksi (230 MPa).
- B. Sheet steel for cold rolled plus painted deck shall conform to ASTM A1008 (A1008M) with a minimum yield strength of 33 ksi (230 MPa). Other structural sheet steels or high strength low alloy steels are acceptable, and shall be selected from the *North American Specification for the Design of Cold-Formed Steel Structural Members*.
- C. Sheet steel for accessories shall conform to ASTM A653 (A653M) Structural Quality for structural accessories, ASTM A653 (A653M) Commercial Quality for non-structural accessories, or ASTM A1008 (A1008M) for either structural or non-structural accessories. Other structural sheet steels or high strength low alloy steels are acceptable, and shall be selected from the *North American Specification for the Design of Cold-Formed Steel Structural Members*.

- D. The deck type (profile) and thickness (gage) shall be as shown on the plans.

2.2 Tolerance:

- A. Uncoated thickness shall not be less than 95% of the design thickness as listed in Table 2.2.1:

Table 2.2.1

Gage No.	Design Thickness		Minimum Thickness	
	in.	mm.	in.	mm.
22	0.0295	0.75	0.028	0.71
21	0.0329	0.84	0.031	0.79
20	0.0358	0.91	0.034	0.86
19	0.0418	1.06	0.040	1.01
18	0.0474	1.20	0.045	1.14
17	0.0538	1.37	0.051	1.30
16	0.0598	1.52	0.057	1.44

- B. Panel length shall be within plus or minus 1/2 inch (12 mm) of specified length.
- C. Panel cover width shall be no greater than minus 3/8 inch (10 mm), plus 3/4 inch (20 mm).
- D. Panel camber and/or sweep shall be no greater than 1/4 inch in 10 foot length (6 mm in 3 m).
- E. Panel end out of square shall not be greater than 1/8 inch per foot of panel width (10 mm per m).

2.3 Finish:

- A. Galvanizing shall conform to ASTM A653 (A653M).
- B. Painted with a shop coat of primer shall be applied to steel sheet conforming to ASTM A1008 (A1008M).
- C. The finish of the steel roof deck shall be suitable for the environment of the structure.

2.3 Finish:

Commentary: The primer coat is intended to protect the steel for only a short period of exposure in ordinary atmospheric conditions and shall be considered an impermanent and provisional coating. Field painting of prime painted deck is recommended especially where the deck is exposed. (See *SDI Field Painting of Steel Deck*).

In corrosive or high moisture atmospheres, a galvanized finish is desirable in a G60 (Z180) or G90 (Z275) coating. In highly corrosive or chemical atmospheres or where reactive materials could be in contact with the steel deck, special care in specifying the finish should be used.

2.4 Design:

A. The deck shall be selected by the designer to provide the load capabilities shown on the drawings (design live and dead loads and the SDI construction loads).

1. The section properties of the steel roof unit deck shall be computed in accordance with the *North American Specification for the Design of Cold-Formed Steel Structural Members*.
2. Allowable Stress Design (ASD): Bending stress shall not exceed 0.60 times the yield strength with a maximum of 36 ksi (250 MPa) under the combined dead and design live loads.
3. Load and Resistance Factor Design (LRFD): The load

factors are defined in the governing code. ASCE 7 (See section 1.2.A.5) shall be used in the absence of a governing code. The resistance factors and nominal resistances shall be determined in accordance with the *North American Specification for the Design of Cold-Formed Steel Structural Members*.

4. Deck Deflection: Deflection of the deck shall not exceed 1/240 of the span (centerline to centerline) or 1 inch (25 mm), whichever is less, under the uniformly distributed design live load. All spans are to be considered center-to-center of supports.

Commentary: The adequacy of deck edge support details should be reviewed by the designer. At the building perimeter or any other deck termination or direction change, occasional concentrated loading of the roof deck could result in temporary differences in deflection between the roof deck and the adjacent stationary building component. Supplemental support such as a perimeter angle may be warranted.

5. Suspended Loads: All suspended loads shall be included in the analysis and calculations for stress and deflection.

Commentary: The designer must take into account the sequence of loading. Suspended loads may include ceilings, light fixtures, ducts or other utilities. The designer must be informed of any loads applied after the roofing has been installed.

6. Construction and Maintenance Loads: Deck shall be selected by the designer to provide a minimum 30 lbs/sq.ft. (1.44 kPa) construction load. Span lengths shall be governed by a maximum stress of 0.7 Fy and a maximum deflection of 1/240 of the span with a 200-pound (0.89 kN) concentrated load at midspan on a 1 foot (300 mm) wide section of deck. If the designer contemplates loads of greater magnitude, spans shall be decreased or the thickness of the steel deck increased as required. All loads shall be distributed by appropriate means to prevent damage to the completed assembly during construction.

7. Cantilever loads: The cantilever span shall be determined by the lowest value considering,
 - (a) construction phase load of 10 psf (0.48 kPa) on adjacent span and cantilever, plus 200 pound load (0.89 kN) at end of cantilever with a stress limit of 0.7 Fy (ASD),
 - (b) a service load of 45 psf (2.15 kPa) on adjacent span and cantilever, plus 100 pound load (0.44 kN) at end of cantilever with a stress limit of 0.6 Fy (ASD), or
 - (c) with service loads, a deflection limitation of 1/240 of adjacent span for interior span and deflection limitation at end of cantilever of 1/120 of overhang.

Commentary: Under Construction and Maintenance Loads, and Cantilever Loads, 0.7 Fy maximum stress was selected to unify the ASD and LRFD values. Apply a load factor of 1.4 to 200 pound load when LRFD is used.

ANSI/SDI-RD1.0 Standard for Steel Roof Deck

8. Diaphragm Shear Capacity: Roof deck shear capacity shall be determined in accordance with the SDI *Diaphragm Design Manual* or from tests conducted by an independent professional engineer.
- surface for the application of roof insulation and roof cover.
- B. Sump pans shall be furnished to receive roof drains as shown on plans. Holes for drains are to be field cut (by others) in the field.
- C. Mechanical fasteners or welds shall be permitted for deck and accessory attachment.

Commentary: Calculations of diaphragm strength and stiffness should be made using the SDI *Diaphragm Design Manual*. If testing is used as the means for determining the diaphragm strength and stiffness, then it should follow the AISI TS 7-02 test protocol.

- B. Load Tables: Uniform loads determined for published tables shall be based on equal adjacent two and three span conditions and on single spans. Appropriate combinations of shear and bending shall be made to determine the published loads. Lengths of 1-1/2 inches (38 mm) for end bearing and 4 inches (100 mm) for interior bearing shall be used to check web crippling. Deflection coefficients shall be 0.013 for single spans, 0.0054 for double spans and 0.0069 for triple spans.

Commentary: For deck layouts that provide more than three equal spans, the user can apply the loads published for three spans. Published uniform load tables do not apply for adjacent spans that differ in length by more than 10%.

2.5 Accessories:

- A. Ridge and valley plates, and flat plates at change of deck direction shall be furnished as shown on plans to provide a flat (finished)

3. Execution

3.1 Installation/General:

- A. Support framing and field conditions shall be examined for compliance with requirements for installation tolerances and other conditions affecting performance of work of this section. All OSHA rules for erection shall be followed.
- B. Deck panels and accessories shall be installed according to the SDI *Manual of Construction with Steel Deck*, placement plans, and requirements of this Section.
- C. Deck panels shall be placed on structural supports and adjusted to final position with ends aligned, and attached securely to the supports immediately after placement in order to form a safe working platform. All deck sheets shall have adequate bearing and fastening to all supports to prevent slip off during construction. Deck ends over supports shall be installed with a minimum end bearing of 1-1/2 inches (38 mm). Deck areas subject to heavy or repeated traffic, concentrated loads, impact loads, wheel loads, etc. shall be adequately protected by planking or other approved means to avoid overloading and/or damage.

- D. Lapped or Butted Ends: Deck ends shall be either lapped or butted over supports. Gaps up to 1 inch (25 mm) shall be permitted at butted ends.
- E. Deck units and accessories shall be cut and neatly fit around scheduled openings and other work projecting through or adjacent to the decking.

Commentary: It is the responsibility of the designer to designate holes/openings to be decked over in compliance with applicable federal and state OSHA directives. Care should be taken to analyze spans between supports at openings, when determining those holes/openings to be decked over. When a framed opening span exceeds the maximum deck span limits for construction loads, the opening must be detailed around instead of decked over. (Minimum roof construction load 30 lbs/sq ft (1.44kPa), unless job specific requirements dictate otherwise).

- F. Trades that subsequently cut unscheduled openings through the deck shall be responsible for reinforcing these openings based upon an approved engineered design.

3.2 Installation/Anchorage:

A. Roof deck units shall be anchored to steel supporting members including perimeter support steel and/or bearing walls by arc spot welds of the following diameter and spacing, fillet welds of equal strength, or mechanical fasteners. Anchorage shall provide lateral stability to the top flange of the supporting structural members and resist the following minimum gross uplifts; 45 pounds per square foot (2.15 kPa) for eave overhang; 30 pounds per square foot (1.44 kPa) for all other roof areas. The dead load of the roof deck construction shall be deducted from the above forces.

1. All welding of deck shall be in accordance with ANSI/AWS D1.3, *Structural Welding Code - Sheet Steel*. Each welder shall demonstrate an ability to produce satisfactory welds using a procedure such as shown in the *SDI Manual of Construction with Steel Deck*, and/or as described in ANSI/AWS D1.3.
2. Welding washers shall be used on all deck units with metal thickness less than 0.028 inches (0.7 mm). Welding washers shall be a minimum thickness of 0.0598 inches (16 gage, 1.50 mm) and have a nominal 3/8 inch (10 mm) diameter hole.
3. Where welding washers are not used, a minimum visible 5/8 inch (15 mm) diameter arc puddle weld shall be used. Weld metal shall penetrate all layers of deck material at end laps and shall have good fusion to the supporting members.

4. Weld spacing: Ribs of panels shall be welded at each support. Space additional welds an average of 12 inches (300 mm) apart but not more than 18 inches (460 mm).
5. When used, fillet welds shall be at least 1-1/2 inches (38 mm) long.
6. Mechanical fasteners, either powder actuated, pneumatically driven, or screws, shall be permitted in lieu of welding to fasten deck to supporting framing if fasteners meet all project service requirements. When the fasteners are powder actuated or pneumatically driven, the load value per fastener used to determine the maximum fastener spacing is based on a minimum structural support thickness of not less than 1/8 inch (3 mm) and on the fastener providing a minimum 5/16 inch (8 mm) diameter bearing surface (fastener head size). When the structural support thickness is less than 1/8 inch (3 mm), powder actuated or pneumatically driven fasteners shall not be used, but screws are acceptable.

Commentary: Mechanical fasteners (screws, powder or pneumatically driven fasteners, etc.) are recognized as viable anchoring methods, provided the type and spacing of the fastener satisfies the design criteria. Documentation in the form of test data, design calculations, or design charts should be submitted by the fastener manufacturer as the basis for obtaining approval.

7. For deck units with spans greater than 5 feet (1.5 m), side laps and perimeter edges of units between span supports shall be fastened at intervals not exceeding 36 inches (1 m) on center, using one of the following methods:
 - a. #10 self drilling screws.
 - b. Crimp or button punch.
 - c. Arc puddle welds 5/8 inch (15 mm) minimum visible diameter, or minimum 1 inch (25 mm) long fillet weld.

Commentary: The above side lap spacing is a minimum. Service loads or diaphragm design may require closer spacing. Good metal to metal contact is necessary for a good side lap weld. Burn holes are to be expected.

B. Accessory Attachment:

1. Accessories shall be anchored to supporting members by arc spot welds or self drilling screws at 12 inches (300 mm) maximum intervals or as shown on design drawings.

Composite Floor Deck Slabs

GENERAL INFORMATION

After installation and adequate fastening, composite steel decks (floor decks) serve several purposes. They act as working platforms, stabilize the frame, serve as concrete forms for slabs, and provide long term positive bending reinforcement. Mechanical interlock and chemical bond resist horizontal shear and provide composite slab action. All Canam composite decks are made to mechanically interlock with the concrete through "rolled in" embossments.

CONSTRUCTION

Deck should be selected to provide a working platform capacity of at least 50 psf. If temporary shoring is required to obtain this capacity, it should be available to support the deck as the deck is being installed. Generally, deck is selected to perform without temporary shores; maximum unshored spans are shown in the tables. The concrete volumes shown in the tables and the weights used to determine unshored spans are nominal and include no additional concrete due to frame deflection. As the deck is being erected, it is important to immediately attach it to the structural frame so a working platform is made. All OSHA rules for erection must be followed. The *SDI Manual of Construction with Steel Deck* is a recommended reference. When placing concrete, care must be taken to avoid high pile ups of concrete and to avoid impacts caused by dropping or dumping. If buggies are used, runways should be planked and deck damage caused by roll bars or careless placement practices should not be allowed. Field cutting that is not shown on the approved erection drawings or changes in fastener types or spacing should be authorized by the designer. Field cutting around openings or for temporary guys can create simple spans where multi spans are intended.

FINISHES

Composite deck is available galvanized (G30, G60 or G90) and "phosphatized/painted". When the deck is furnished "phosphatized/painted", only the side not in contact with the concrete is painted so chemical bond between steel and concrete can occur. ("Phosphatizing" is a cleaning process.) When spray proofing is required over phosphatized/painted deck, this must be clearly shown in the contract documents. Surface cleaning and both selection and adhesion of field applied paints or spray proofing are the responsibility of the coating contractor.

VENTING

With the increased use of sealers on concrete slabs and more stringent regulations concerning solvent emissions at job sites, venting requirements are sometimes specified to allow curing and drying of structural concrete. Venting has long been specified with lightweight insulation fills. Venting is a function of vent area and spacing and is typically located in the bottom flats of flutes. The venting requirement must be provided by the designer or sealer manufacturer. Vents are not possible with cellular deck and integral hanger tabs are commonly used in composite deck. The nominal vent area provided by integral hangers in composite deck is ¼% but ½% is available in some circumstances. When venting is a concern, properly designed (rich) concrete mixes and curing time before sealing will significantly help.

WIRE MESH

Temperature reinforcing should be present in composite slabs. The wire mesh recommendations shown in the tables follow the SDI recommendation for a steel area of 0.00075 times the area of concrete above the deck flutes and not less than 6x6-W1.4x1.4. The mesh shown in the tables is not proportioned to act as negative reinforcement but it does add some strength to the system. **If welded wire fabric is not used, building occupancy must not require distribution steel.** For best crack control, mesh should be kept near the top of the slab in negative bending regions (¾" to 1" cover) – shrinkage and bending cracks are possible over supports. Mesh also helps to distribute loads, both during construction and during the service life of the slab. It can also be a secondary safety device if there is a collapse during concrete placement.

PARKING GARAGES

Composite floor deck is not recommended for parking garages in the northern part of the United States; salt introduced and caused by snow removal can deteriorate the deck. Deck can be used as a permanent form and reinforcing (mesh or bars) should be used. If sealing membranes are used, allow sufficient time or other means for concrete curing. Negative steel may be required to control strain in the membrane.

FORK LIFTS

The SDI design method for concentrated loads is shown on this page and on page 33 and slabs have been used to support fork lifts. Dynamic and repetitive loads can overcome bond and interlock. When very repetitive moving traffic is anticipated, it is recommended that the slab be designed as a conventional reinforced slab or that the required composite slab bending strength be less than ½ the factored nominal capacity and that negative steel and distribution steel be designed.

THE TABLES

The tables are arranged so the composite properties are on the left page. The uniform live load capacities are shown on the right page. Tables are provided for both light weight and normal weight concrete; both types assume a concrete strength of 3000 psi. The published uniform live load is the unfactored service load, typically obtained in codes. The tables are based on steel yield strength of 40 ksi; however, 50 ksi minimum yield steel is also available with sufficient lead time and quantity and tables based on this strength are available upon request. SDI allows 50 ksi as the maximum design strength in the determination of slab capacities. Maximum unshored spans are defined on the left page. These spans may be taken as clear spans and SDI Construction loading is used to determine the values. The tabulated variables are shown on each page. Composite deck section properties conform to the 2007 edition of the North American Specification and the tables consider web crippling produced by the SDI loading. The slab capacities agree with the generic 40 ksi values published by SDI.

The research done on composite deck has shown that the presence of shear studs influences the resistance of the system. When a sufficient number of shear studs are present, the composite slab can achieve its predicted ultimate strength. When no shear studs are present the factored moment is found by $M_{no} = \phi S_c F_y$, where ϕ is 0.85 and S_c is the cracked composite section modulus of the composite slab. If the number of studs present is between the amount required to produce the "fully" studded moment and zero, then a straight line interpolation is valid. Generally, the load capacity of composite slabs is greater than required by the intended use, and the number of studs is not of importance. Studs are used primarily to make beams composite and the composite slab simply uses what is there. The tables show the number of studs to develop M_{nf} - the average number of studs (per foot of beam) can be compared to this value. The right page tables are therefore divided into two parts. Those with one stud per foot and those with no studs – One stud per foot typically develops M_{nf} . Both tables assume that no negative bending reinforcement is in place and the composite deck has been analyzed as a single span. The loads have been determined by solving the equation for W_c (the live load): $1000 \times M = [1.6 W_c + 1.2 W_d] L^2 (12)/8$ where M is the appropriate listed factored moment (in kip), either ϕM_{nf} or ϕM_{no} ; W_c is the sum of the concrete and deck weight in psf; L is the span in feet. Although other load combinations may be investigated, $1.6 W_c + 1.2 W_d$ usually controls. An upper load limit of 400 psf has been applied. This is to guard against uniform loads being equated from heavy concentrated loads which require more analysis. Uniform loads greater than 400 psf can be analyzed by using the data provided. A rational shear span is required to develop the moment, M_{no} ; generally a distance of 2.5 ft between zero and maximum moment is sufficient. Concentrated loads can be designed as shown in the following method and an example problem on page 33.

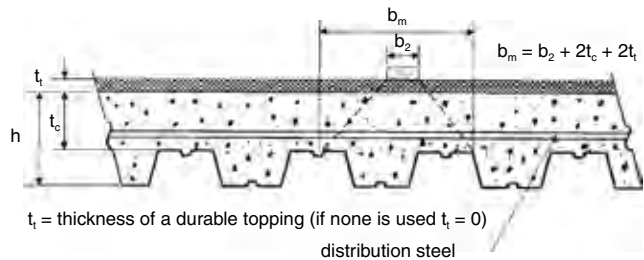

DISTRIBUTION OF CONCENTRATED LOADS

The load width (above the ribs) is given by:

$$b_m = b_2 + 2t_c + 2t_t$$

The effective slab width (b_e) formulas are:

$$\text{single span bending: } b_e = b_m + 2(1 - x/l)x$$

Single span bending distribution is to be used if negative bending reinforcing steel is not placed over the supports.

$$\text{continuous span bending: } b_e = b_m + 4/3 (1 - x/l)x$$

Continuous span bending is to be used if negative bending reinforcing steel is present over the supports.

$$\text{For shear (single span or continuous) } b_e = b_m + (1 - x/l)x.$$

But, in no case shall b_e be $> 8.9(t_c/h)$, feet.

The **Weak Axis Moment** (for distribution steel); M (weak axis) = $\frac{Pb_e}{15w}$
where w is the distribution length parallel to the ribs:

$$w = l/2 + b_3; \text{ but not to exceed } l$$

l = span length; x = location of the load measured from the support;

b_2 = load width perpendicular to the flutes; b_3 = load width parallel to the flutes.

GENERAL INFORMATION



Suggested Specifications

1. Material and Design*

- Composite floor deck shall be UNITED STEEL DECK type_____ as manufactured by Canam, from steel conforming to ASTM A1008 or ASTM A653 with minimum yield strength (Fy) of 40 ksi.
- Floor deck shall extend over three or more spans if possible. [The depth and gage of floor deck shall be selected to not exceed the un-shored spans as calculated using LRFD methods under the construction loadings recommended by SDI.]** Deflection relative to support beams and caused by the dead load of wet concrete and deck shall not exceed L (deck span)/180 or 3/4".
- Live load capacities shall be calculated in accordance with the SDI Composite Deck Design Handbook. The type and gage of the metal floor deck shall be selected to carry, acting compositely with the concrete slab, the superimposed live loads shown on the project drawings without exceeding a deflection of 1/360 of the span.

2. Finishes

- Galvanizing shall conform to the requirements of ASTM A653 coating class G30, G60 or G90 or Federal Specification QQ-S-775e, class d or class e.

or

- Primer paint shall be shop applied over cleaned and phosphatized steel - paint applied only on the exposed side of the deck. The side of the deck that is to be in contact with the concrete is to be uncoated or galvanized.

3. Tolerances

Manufacturer's standard tolerances apply. (Deck sheet length is plus or minus 1/2".) Base steel thickness shall be greater than or equal to 95% of the design thickness. (This is consistent with the SDI and AISI Standards.)

4. Installation

- Installation of floor deck and accessories shall be done in accordance with the SDI Manual of Construction with Steel Deck and as shown on the approved erection drawings. **To form a working platform, immediately fasten sheets to the supports.** Welds to supports shall be 5/8" diameter puddle welds with an average weld spacing of at least 12" (15" for B Lok) on center. Side laps are to be welded at a maximum spacing of 36" on center for spans over 5'0". (Button Punches or fasteners other than welds may be acceptable to Canam. Refer to the UL Design (if required) for other restrictions.)
- Deck shall be butted over supports. (End lapping or staggering are not recommended.) As deck profile dictates, overlap at interlocking side-laps or nest side-laps without back lapping. Maintain end alignment. Minimum bearing of deck ends on supports shall be 1 1/2" unless otherwise shown.
- Floor openings located and detailed on the structural drawings shall be cut by the floor deck contractor. Holes for other trades plus any reinforcing for these holes shall be cut and reinforced by the other trades. (OSHA Regulations require that most openings be decked over during construction – 29CFRSection 1926.754(e)(2)(2003.)
- All sheets from opened bundles must be fastened before the end of the working day; bundles must be left secured to prevent wind blowing the individual sheets.
- (Eliminate when shoring is not required): Shoring shall be present at time of deck placement. Do not remove shoring until the concrete has attained 75% of its design compressive strength and in no case less than 7 days or as instructed by the Engineer of Record. (Shoring, shoring design, and design of structure to accept shoring loads are not by Canam.)
- Maximum unshored spans, slab thickness, and concrete density shall be posted on the erection drawings.

5. Concrete

- Placement of concrete shall conform to the applicable sections of the ACI Specifications and the SDI Manual of Construction with Steel Deck. If buggies are used, the deck shall be planked to prevent damage. Contractor shall not exceed the SDI construction loads during either concrete placement or finishing. *Ponding of concrete and large screed machines or buggies should be avoided unless special project loading is defined in the contract documents and maximum unshored spans are determined prior to approval of the erection layout.*
- Calcium Chloride: Calcium Chloride (or any admixture containing chloride salts) shall not be used in concrete placed on products manufactured by Canam.

6. Site Storage

(Steel deck delivery should be scheduled to arrive at the jobsite as required for erection.) If site storage is needed, the bundles of deck (either painted, uncoated, or galvanized) shall be stored off the ground with one end elevated to provide drainage, and shall be protected against condensation with a ventilated waterproof covering.

* Note: The long form ANSI/SDI-C1.0 Standard for Composite Steel Floor Deck is included at page 66.

** Eliminate this clause if shoring is allowed. Indicate any required shoring zones on the contract drawings especially in areas where there are skewed walls and discontinuous deck spans around elevator shafts and stair towers. When required by the contract drawings, shoring should be shown on the approved erection drawings.

Content of Composite Deck Tables

Two sets of tables are provided, the first is normal weight concrete (145 pcf) and the second is light weight concrete (115 pcf). The presentation is identical for all but N-LOK.

The **Deck Properties** at the top of the left pages are per foot of width. **t** is the gage thickness in inches, **w** is the deck weight (psf), **I** is the moment of inertia for positive bending (in.⁴/ft.), **S_p** and **S_n** are the section moduli for positive and negative bending (in.³/ft.), ϕR_{ps} , ϕR_{pn} , and ϕV_n are the LRFD based factored exterior and interior reactions and the shear resistance (lb./ft.); and **studs** is the number of studs required per foot to obtain the full resisting moment of the slab, **M_{nr}**.

The **Composite Properties** at the bottom of the left pages are a list of design or resistance values for the composite slab; all are **per foot of width**. As shown on the sketch, the slab depth is the distance from the bottom of the steel deck to the top of the slab (in.). U.L. ratings generally refer to the cover over the top of the deck so it is important to be aware of the difference in definition. ϕM_{nr} is the factored resisting moment provided by the composite slab when the "full" number of studs shown in the upper table are in place (in. kips/ft.). **A_c** is the area of concrete available to resist shear (in.²/ft.). **Vol.** is the volume of concrete needed to make up the slab (ft.³/ft.²) and includes no allowance for frame or deck deflection. **W** is the concrete weight (lb./ft.²) and equals Vol. x concrete density. **S_c** is the transformed section modulus of the "cracked" concrete composite slab (in.³/ft.). **I_{av}** is the average of the "cracked" and "uncracked" moments of inertia of the transformed composite slab (in.⁴/ft.). Section properties are transformed to steel; therefore, to calculate deflections the appropriate modulus of elasticity is 29.5 x 10⁶ psi. ϕM_{no} is the factored resisting moment of the composite slab with no studs on the beams (the deck must be attached to the beams or walls on which it is resting) (in. kips/ft.). ϕV_{nt} is the factored vertical shear resistance of the composite system (lb./ft.); it is the sum of the shear resistances of the steel deck and the concrete but is not allowed to exceed $\phi 4(f'c)^{1/2}A_c$. The next three columns list the **maximum unshored spans** (ft.); these values are obtained using the construction loading requirements of the SDI. Combined bending and shear, deflection, and reactions are considered in calculating these values. **A_{wrr}** is the area of welded wire fabric meeting the SDI minimum temperature steel requirement. Randomly distributed fibers must be allowed by the local code and be acceptable as part of the fire rating requirements before substitution is considered. Fibers may not perform as distribution steel.

The **Uniform Live Loads** on the right pages are based on the SDI Composite Deck Design Handbook and the LRFD equation, $\phi M_n = (1.6L + 1.2D)^{1/2} / 8$. Service loads are listed in the tables. Although there are other load combinations that may require investigation, this will control most of the time. The equation assumes there is no negative bending reinforcement over the beams and therefore each composite slab is a single span. Two sets of values are shown and repeat the values on the left page: ϕM_{nr} is shown at the top and is used to calculate the uniform load when the full required number of studs is present, and ϕM_{no} is shown at the bottom and is used to calculate the load when no studs are present. A straight line interpolation can be done if the average number of studs is between zero and the required number needed to develop the "full" factored moment. The tabulated loads are checked for shear controlling (it seldom does), and also are limited to a live load deflection of 1/360 of the span.

An upper limit of 400 psf has been applied to the tabulated loads. This has been done to guard against approximating large concentrated loads as uniform loads over a foot print. Concentrated loads may require special analysis and design to take care of serviceability requirements not covered by simply using a uniform load value. On the other hand, for any load combination the resistance values provided by the composite properties can be used in the calculations. The slab capacity for 16 gage product defaults to the value at 18 gage.

The N-LOK table presents the same variables but only shows the resistance value, ϕM_{no} , since it is not efficient with studs in composite beam action. Uniform service loads are not provided but may be calculated using the resistance values. Refer to the example problems for the use of the tables.

SPECIFICATIONS



SDI Formulas for Construction Loads

Clear spans may be used in the formulas. For checking web crippling (bearing) the uniform loading cases of concrete weight plus 20 psf or concrete weight plus 150 lbs./ft. width concentrated are used. Both exterior and interior reactions are checked but a 10% redistribution allowance is made at exterior reactions. Contractor shall not exceed the SDI construction loads during either concrete placement or finishing.

FLOOR DECK

SINGLE SPAN

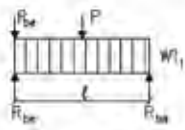

$$+M = .25Pl + 0.125W_1l^2$$

$$R_{be} = .5W_1l + P_{be}$$

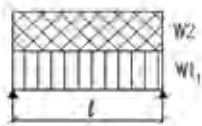

$$+M = .125(W_1 + W_2)l^2$$



$$\delta = \frac{.0130W_1l^4}{EI} (1728)$$



$$R_{be} = .5(W_1 + W_2)l$$

DOUBLE SPAN

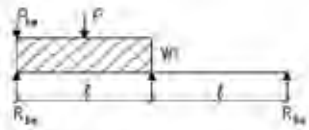

$$+M = .203Pl + .096W_1l^2$$

$$-M = .094Pl + .063W_1l^2$$

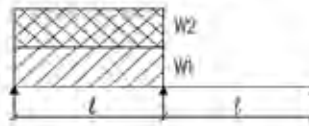

$$+M = .096(W_1 + W_2)l^2$$

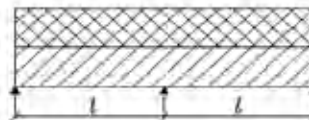

$$-M = .125(W_1 + W_2)l^2$$

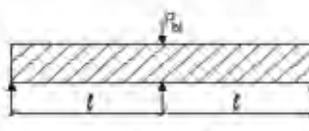

$$\delta = \frac{.0054W_1l^4}{EI} (1728)$$

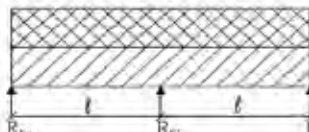

$$R_{be} = .375(W_1 + W_2)l$$

$$R_{bi} = .437W_1l + P_{bi}$$

$$R_{bt} = 1.25(W_1 + W_2)l$$

$$R_{bt} = 1.25(W_1)l + P_{bt}$$

TRIPLE SPAN

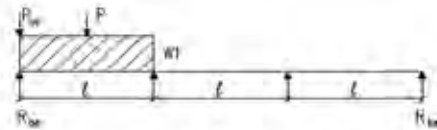

$$+M = .20Pl + .094W_1l^2$$

$$-M = .1Pl + .067W_1l^2$$

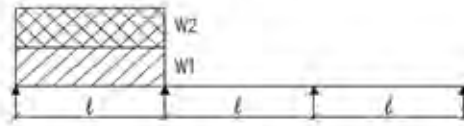

$$+M = .094(W_1 + W_2)l^2$$

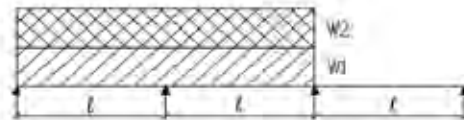

$$-M = .117(W_1 + W_2)l^2$$

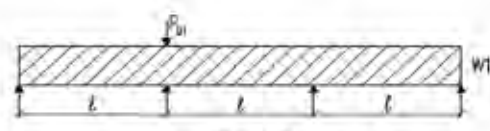

$$\delta = \frac{.0069W_1l^4}{EI} (1728)$$

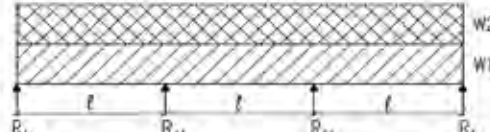

$$R_{be} = .4(W_1 + W_2)l$$

$$R_{bi} = .433W_1l + P_{bi}$$

$$R_{bt} = 1.2W_1l + P_{bt}$$

$$R_{bt} = 1.2(W_1 + W_2)l$$

For single span only, the concrete load (W1) shall include either an additional 50% of the concrete weight or 30 psf whichever is less.

Deflection is to be calculated using only concrete plus deck weights uniformly distributed over all spans.

Dimensional check shows the need for the 1728 factor when calculating deflection using pound inch units.

P or P_{be} or P_{bt} = 150 pound concentrated (man) load

I = in⁴/ft - deck moment of inertia

E = 29.5 x 10⁶ psi

l = clear span length in feet. (When shores are used clear span is not the structural support span but the shoring span.)

W₁ = slab weight + deck weight

W₂ = 20 pounds per square foot construction load

W₁ = 1.5 x slab weight + deck weight ± slab weight + 30 = deck weight

P_{be} = location of a moving man load (P) for maximum exterior reaction - only one load is present in a span

P_{bt} = location of moving man load (P) for maximum interior reaction

SPECIFICATIONS

Composite Floor Deck Design - Example Problem

For the composite floor deck, composite section properties and concentrated load example problems, the following data from the Canam Steel Decks for Floors and Roofs manual will be used and are worked using LRFD methodology.

Deck Type – 2" LOK-FLOOR COMPOSITE
 Gage - 20 (t=0.0358")
 Yield Stress – 40 KSI (MINIMUM)
 The deck properties (per foot of width) have been calculated in accordance with the AMERICAN IRON AND STEEL INSTITUTE (AISI) SPECIFICATIONS and are:
 $I_p = 0.390 \text{ in.}^4$ (Moment of inertia in positive bending);
 $S_p = 0.332 \text{ in.}^3$ (Section modulus in positive bending);
 $S_n = 0.345 \text{ in.}^3$ (Section modulus in negative bending);
 $A_s = 0.54 \text{ in.}^2$ (Steel deck area per unit width);
 $\phi R_{w1} = 1360 \text{ lbs.}$ (Factored web crippling capacity based on 5" interior bearing);
 $\phi R_{w2} = 800 \text{ lbs.}$ (Factored web crippling capacity based on 2.5" exterior bearing);
 $\phi V_w = 2930 \text{ lbs.}$ (Factored deck shear strength);
 $w = 1.8 \text{ psf.}$ (Deck weight)
 SDI tolerances apply.
 The concrete properties are:
 $f'_c = 3 \text{ ksi}$ (Concrete strength);
 $\gamma = 145 \text{ pcf}$ (Concrete density);
 Modular ratio, $n^* = E_s/E_c = 9$

*The current AISC/SDI method of calculating E_c is:

$E_c = \gamma^{1.5} \sqrt{f'_c}$, $ksi = 145^{1.5} \sqrt{3.0} \times 1000 = 3.024 \times 10^6 \text{ psi}$ $E_s = 29.5 \times 10^6 \text{ psi}$
 So modular ratio $n = 9.75$.
 However, for the sake of consistency with the composite deck tables, we will use the n historically used by SDI, which is 9 and gives an $E_c = 3.28 \times 10^6 \text{ psi}$.

Unshored Span Calculation

Calculate the maximum unshored clear span for the three span condition of the deck with a 4.5" slab. The resistance factors are provided by the AISI Specifications. The load factors are **1.6 for concrete weight, 1.4 for construction loading of men and equipment, and 1.2 for the deck dead load**. It is important to remember that these factors are for the deck under the concrete placement loads; when the slab has cured, and the system is composite, the factors are different.

REFER TO PAGE 30 FOR FIGURE SHOWING 3 SPAN CONDITION.

$W1 = w_{\text{concrete}} + w_{\text{deck}} = 42 \text{ psf} + 1.8 \text{ psf}$; $W2 = \text{construction load} = 20 \text{ psf}$.

$\phi = 0.95$ and is the AISI resistance factor using the deck as a form,
 $F_y = \text{yield stress of steel deck} \leq 60 \text{ ksi}$

Bending is checked using the controlling sequential loading.

Check negative bending with two spans loaded: where $l = \text{span}$, applied bending moment – $M = 0.117(W1 + W2)l^2$ and deck resistance = $\frac{\phi F_y S_n}{12}$

Solving for length:

$$0.117 l^2 (1.6 \times 42 + 1.4 \times 20 + 1.2 \times 1.8) = \frac{0.95(40000)(0.345)}{12}; l = 9.79'$$

Now check positive bending with one span loaded with concrete and the concentrated load:

$$+M = 0.20Pl + 0.094Wl^2, \text{ Deck Resistance} = \frac{\phi F_y S_p}{12}$$

$$0.20(1.4 \times 150)l + 0.094(1.6 \times 42 + 1.2 \times 1.8)l^2 = \frac{0.95(40000)(0.332)}{12}; l = 9.88'$$

Check positive bending with one span loaded with concrete and construction load:

$$+M = 0.094(W1 + W2)l^2, \text{ Deck Resistance} = \frac{\phi F_y S_p}{12}$$

$$0.094(1.6 \times 42 + 1.2 \times 1.8 + 1.4 \times 20)l^2 = 1051.33; l = 10.72'$$

Web crippling, shear, and the interaction of bending and shear are checked with two spans loaded. Check interior web crippling with:

$$\phi R_{w1} = 1.2(W1)l + P \text{ or } \phi R_{w1} = 1.2(W1 + W2)l$$

$$\phi R_{w1} = 1.2(1.6 \times 42 + 1.2 \times 1.8)l + 1.4 \times 150 = 1360; l = 13.82' \text{ or}$$

$$\phi R_{w1} = 1.2(1.6 \times 42 + 1.2 \times 1.8 + 1.4 \times 20)l = 1360; l = 11.64'$$

Check exterior web crippling:

$$\phi R_{w2} = 0.433(W1)l + P \text{ or } \phi R_{w2} = 0.4(W1 + W2)l$$

$$\phi R_{w2} = 0.433(1.6 \times 42 + 1.2 \times 1.8)l + 1.4 \times 150 = 800; l = 19.65' \text{ or}$$

$$\phi R_{w2} = 0.4(1.6 \times 42 + 1.2 \times 1.8 + 1.4 \times 20)l = 800; l = 20.54'$$

Shear or bending alone will not control, but the interaction of shear and bending could. The AISI equation C3.3.2-1 for interaction is:

$$\sqrt{\left(\frac{M}{\phi_b M_n}\right)^2 + \left(\frac{V}{\phi_v V_n}\right)^2} \leq 1.0$$

$$-M = 0.117(W1 + W2)l^2 = .117l^2(1.6 \times 42 + 1.4 \times 20 + 1.2 \times 1.8) = 136.69l^2$$

$$\phi_b M_n = 0.95F_y S_n = 0.95 \times 40000 \times 0.345 = 13110 \text{ in-lbs.}$$

$$V_{\text{applied}} = 0.617(W1 + W2)l = 0.617(1.6 \times 42 + 1.4 \times 20 + 1.2 \times 1.8)l = 60.07l$$

$$\sqrt{\left(\frac{136.69l^2}{13110}\right)^2 + \left(\frac{60.07l}{2930}\right)^2} \leq 1.0 \quad l = 9.69'$$

Check deflection with $\delta = l/180$ and with $\delta \leq 0.75"$

$$\delta = \frac{0.0069(W1)l^4}{EI} \quad \delta = \frac{.0069(42 + 1.8)l^4 \times 1728}{29.5 \times 10^6 \times 0.390} = \frac{lx12}{180} \quad l = 11.36'$$

$$\delta = \frac{.0069(42 + 1.8)l^4 \times 1728}{29.5 \times 10^6 \times 0.390} \leq 0.75" \quad l = 11.34'$$

Combined bending shear governs, tables show a maximum unshored span of 9.67" and agrees well with 9.69".

Composite Section Properties

Calculate the composite section properties and the allowable uniform load for the deck combination. The clear span is 9'. No negative bending reinforcing is used over the beams, so the composite slab will be a simple span.

Determine the "cracked" moment of inertia (I_{cr}). This calculation is the standard ASD calculation which assumes all concrete below the neutral axis is cracked. The concrete is transformed into equivalent steel.

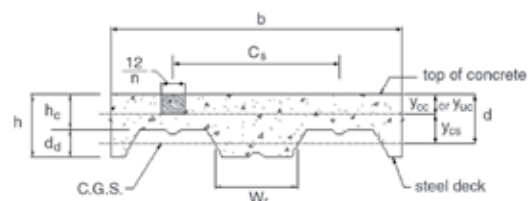

When y_{cc} is equal to or less than the depth of concrete above the top of steel, h_c , that is, $y_{cc} \leq h_c$, then

$$y_{cc} = d \sqrt{2\rho n + (\rho n)^2 - \rho n} \quad \text{where } \rho = \frac{A_s}{bd} = \frac{0.54}{12(4.5-1)} = 0.0129$$

$$y_{cc} = 3.5 \sqrt{2(.0129 \times 9) + (.0129 \times 9)^2 - .0129 \times 9} = 1.328 = 1.33" < 2.5" O.K.$$

Determine I_{cr} : where $y_{cs} = d - y_{cc} = 3.5 - 1.33 = 2.17"$

$$I_{cr} = \frac{b}{3n} y_{cs}^3 + A_s y_{cs}^2 + I_g \quad I_{cr} = \frac{12}{3 \times 9} 1.33^3 + 0.54 \times 2.17^2 + 0.39 = 3.98 \text{ in.}^4$$

$$\text{Determine cracked section modulus: } S_c = \frac{I_{cr}}{h - y_{cc}} = \frac{3.98}{4.5 - 1.33} = 1.25 \text{ in.}^3$$

Table's print out shows 1.25 which checks.

EXAMPLE PROBLEM



Determine un-cracked moment of inertia (I_u). The concrete is again transformed into equivalent steel.

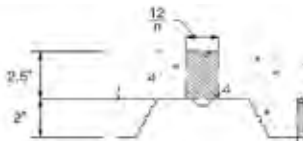

Using the top of the slab as the reference line:

$$y_{cs} = \frac{0.5b^3 + n(d + W_s d_s)(h - 0.5d_s)^2 \frac{b}{C_c}}{nW_s + nA_s + W_s d_s \frac{b}{C_c}}$$

$$= \frac{(0.5)(12)^2(2.5)^2 + 9(0.54)(3.5 + 6)(2)(1.5 - 0.5)(2)^2 \frac{12}{12}}{12(9) + 9(0.54) + 6(9)(2) \frac{12}{12}} = 2.06 \text{ in.}$$

and $y_{cs} = d - y_{st}$ $y_{st} = 3.5 - 2.06 = 1.44"$

and the uncracked I is:

$$I_u = \frac{bh^3}{12n} + \frac{bh}{n}(y_{cs} - 0.5d_s)^2 + I_{cs} + A_s y_{st}^2 + \frac{W_s b d_s^3}{n C_c} \left[\frac{d_s^2}{12} + (h - y_{cs} - 0.5d_s)^2 \right]$$

$$I_u = \frac{12(2.5)^3}{12(9)} + \frac{12(2.5)}{9} (2.06 - 0.5)(2.5)^2 + 0.39 + 0.54(1.44)^2$$

$$+ \frac{6(12)(2)^3}{9(12)} \left[\frac{2^2}{12} + (4.5 - 2.06 - 0.5)(2)^2 \right] = 8.64 \text{ in.}^4$$

Moment of inertia of composite section considered effective for deflection computations is:

$$I_{e,cs} = \frac{I_u + I_{cs}}{2} \quad (\text{Transformed to steel}) \quad I_{e,cs} = \frac{8.64 + 3.98}{2} = 6.3 \text{ in.}^4 \text{ This agrees with tables.}$$

Calculate the live load allowed for the case with no studs with clear span = 9 feet. The nominal resisting moments where the ϕ factor is 0.85 is: $\phi M_n = \phi F_y S_x = 0.85(40000)(1.25) = 42500 \text{ in.-lbs.}$ The table shows 42.94 in.-k which checks within 1%.

Unless negative bending is present, the composite slab is assumed to be single span. For single span, the un-factored uniform (live) load (W_L) is found by:

$$\phi M_n = \frac{(1.6W_D + 1.2W_L)l^2 \times 12}{8} \quad W_D = \text{dead load} = 42 + 1.8 = 43.8 \text{ psf. Solve for } W_L$$

$$W_L = \frac{8(42500 \text{ in.-lbs.} - 12(43.8 \text{ psf}) \times 9^2 \text{ ft.} \times 12 \text{ in./ft.})}{1.6 \times 12 \text{ ft.} \times 12 \text{ in./ft.}} = 186 \text{ psf}$$

This is within 2% of the 190 psf value published in the table.

Check deflection if applied load is 190 psf. SDI maximum deflection is 0.75" or L/180.

$$\delta = \frac{0.013Wl^4}{E I_{e,cs}} = \frac{0.013(190)(9^4)(12^3)}{29.5(10^3)(6.3)} = 0.15" < 0.75" \text{ and } < \frac{l}{180} \text{ which is O.K.}$$

Check the factored vertical shear capacity: $\phi V_{steel\ deck} = 2930$ pounds (per foot of width). Where A_c is the concrete trapezoidal (shaded) area available to resist shear = 32.6 in² from table.

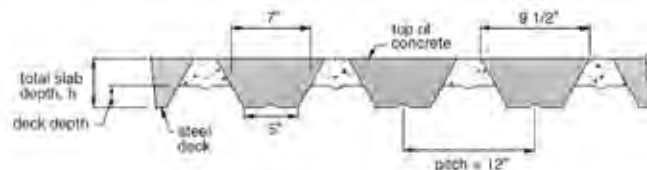

If the slab depth causes the area to overlap, then the area is adjusted to not exceed the shape provided with the deck pitch as the top dimension.



$$\phi V_{concrete} = \phi 2(f_c')^{1/2} A_c = .85(2)(3000)^{1/2}(32.6) = 3035 \text{ lbs.}$$

The factored shear resistance of the composite slab $V_n = 2930 + 3035 = 5965 \approx 5970 \text{ lbs.}$

The total of the $\phi V_{steel\ deck}$ and the $\phi V_{concrete}$ is not allowed to exceed the concrete shear control limit of:

$$\phi 4(f_c')^{1/2} A_c = .85(4)(3000)^{1/2}(32.6) = 6071 \text{ lbs.} > \text{the tabulated } 5970 \text{ lbs. O.K.}$$

Note: if the concrete density $\leq 130 \text{ pcf}$ V is multiplied by 0.75.

The un-factored live load allowed if shear controls (W_L) is found by:

$$5965 = \frac{(1.6W_D + 1.2W_L)l}{2} \quad \text{Solve for } W_L$$

$$W_L = \frac{5965(2) - 1.2W_D l}{1.6} = \frac{5965(2) - 1.2(43.8)(9)}{1.6} = 796 \text{ psf} < 190 \text{ psf}$$

so shear does not control. O.K.

The number of studs required to develop 100% of the factored moment is given by:

$$N_s = \frac{F_y(A_c - A_{cs})}{0.22(f_c' E_s)^{1/2}} \quad N_s = \frac{40(54 - 0.16(2 - 0.179))}{0.22(3000(3.28 \times 10^3))^{1/2} + 1000} = 0.51$$

studs per foot, which checks the table.

The inverse $1/0.51 = 1.95$ which means a stud is required every 1.95 feet in order to achieve the full factored moment.

The nominal (ultimate) moment capacity with studs on beam:

$$\phi M_n = \phi (F_y (d - a/2)) \quad \text{where } (a) \text{ is the depth of the concrete}$$

$$\text{compression block and is given by: } a = \frac{A_c F_y}{0.85 f_c' b}$$

$$\text{where } (b) \text{ is the unit width of } 12". \quad a = \frac{0.54(40000)}{0.85(3000)(12)} = 0.71"$$

$$\phi M_n = 0.85(0.54)(40000)(3.5 - 0.71/2) = 57780 \text{ in.-lbs.}$$

The tables show 57.78 in-k which checks.

Since $N_s = 0.51$ and $1/N_s = 1.95'$, studs spaced at 1' will develop the full factored moment of 57.78 in-k, and with no studs the composite slab develops 42.94 in-k. When the shear studs are present on the beam supporting the composite steel deck, but are not present in sufficient quantity to develop the ultimate capacity of the section in bending then the composite slab capacity is found by interpolation. If studs are spaced at 3' ($1/3 = 0.33$ studs per foot) then the usable nominal moment capacity at stud density N_s' is:

$$\phi M_n = M_{no\ studs} + (M_{studs} - M_{no\ studs}) \frac{N_s'}{N_s}$$

$$\phi M_n = 42.94 + (57.78 - 42.94) \frac{0.33}{0.51} = 52.49 \text{ in.-k} \leq 57.78 \text{ in.-k}$$

Example Problem for a Concentrated Load

Consider the same deck as in the previous example (page 31). This problem is designed to demonstrate how to check the ability of a composite slab to carry a 3000 lb point load over an area of 4.5" x 4.5" occurring anywhere in the span. This problem is consistent with the requirements of the 2006 International Building Code for garages storing vehicles accommodating not more than nine passengers.

There will be no other live load acting simultaneously, and there is no negative bending reinforcement present over the supports, therefore we assume a single span condition.

For this example the following criteria apply:

Clear Span - 9 ft. -- Maximum Unshored Span is 9.67 ft

Slab Thickness - 4.5 in.

Composite Properties:

ϕM_{no} - 42.94 in.k

ϕM_{nf} - 57.78 in.k

w_{deck} - 1.8 psf

w_{slab} - 42 psf

I_{av} - 6.3 in⁴/ft

ϕV_{nt} - 5970 lbs.

$b_2 = b_3 = 4.5$ in.

$b_m = b_2 + 2t_c + 2t_t$

t_c = Thickness of concrete cover over the top of the deck

t_t = Thickness of any additional topping

h = Total thickness exclusive of topping

t_t = 0 in.

t_c = 2.5 in.

h = 4.5 in.

$b_m = 4.5 + 2(2.5) + 0 = 9.5$ in.

For moment and for determining the distribution steel, put the load in the center of the span.

$b_e = b_m + 2(1-x/l)x$; where x is the location of the load: $x = l/2$

$b_e = 9.5 + 2(1-54/108)54 = 63.5$ in.; However $b_e < 8.9(t_c/h)$ in feet
 $8.9(2.5/4.5)(12) = 59$ in. therefore $b_e = 59$ in.

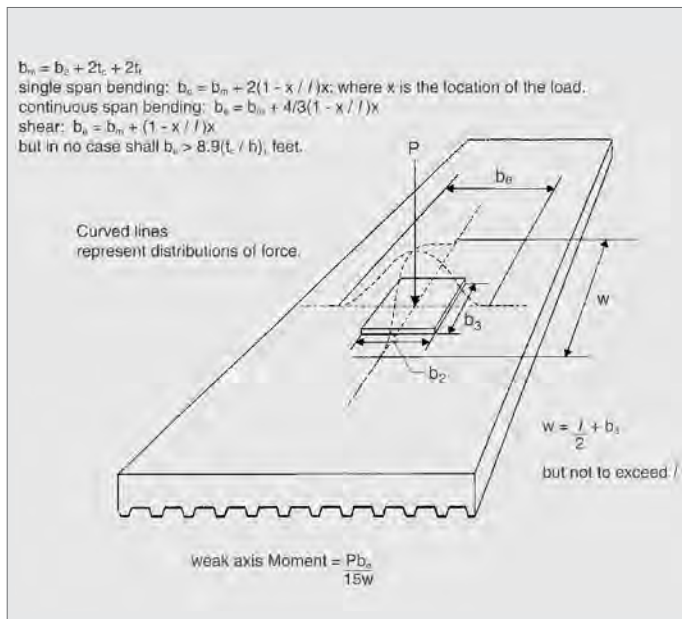

FIGURE 1

Check vertical shear :

Put the load one slab depth away from the beam; $x = h$

$b_{ve} = b_m + (1-x/l)x = 9.5 + (1-4.5/108)4.5 = 13.8 < 59$

For Moment $b_e = 59$ in.

For Shear $b_{ve} = 13.8$ in.

Live load moment (per foot of width) = $Pl/4$

= $(1.6)(3000)(9/4)(12/59)(12)/1000$

$Pl/4 = 26.36$ in.k;

1.6 is the load factor and 12/59 is the distribution factor

w_{total} = Total dead load = $w_{slab} + w_{deck} = 42 + 1.8 = 43.8 \cong 44$ psf;

1.2 is the load factor.

Dead load moment = $w_{total}l^2/8 = 1.2(44)(9)^2(12)/8000 = 6.42$ in.k

$26.36 + 6.42 = 32.78$ in.k

ϕM_{no} ; Factored resisting moment when studs are not present on the beams

$\phi M_{no} = 42.94$ in.k > 32.78 in.k **O.K.**

$V = 1.6(3000)(12/13.8) + 1.2(44)(9)/2 = 4412$ lbs

$\phi V_{nt} = 5970$ lbs > 4412 lbs **O.K.**

Find the required distribution steel (welded wire mesh)

M_2 = Weak direction moment = $Pb_e/15W$

$W = l/2 + b_3 = 54 + 4.5 = 58.5$ in. < 108 in.

$M_2 = 1.6(3000)(59)(12)/(15 \times 58.5) = 3873$ in.lbs/ft

Assume the wire mesh is located 1/2" above top of deck;

$d = 4.5 - 2 - 0.5 = 2$ in.

$M_n = A_s F_y (2-a/2)$

A_s is the area per foot of the wire mesh which has an F_y of 60 ksi.

If the bars are being investigated, the F_y would have to be adjusted accordingly.

$a = A_s F_y / 0.85 f'_c b$; $b = 12$ in.

Assume A_s is the area of 6 x 6 - W2.0 x W2.0 mesh. $A_s = 0.04$ in²/ft.
 6 x 6 - W1.4 x W1.4 mesh is the ANSI/SDI minimum.

$a = 0.040(60000)/(0.85 \times 3000 \times 12) = 0.078$ in.

NOTE: $\phi = 0.9$ in ACI but SDI uses 0.85

$\phi M_{weak} = 0.85(0.040)(60000)(2-0.078/2) = 4000$ in.lbs/ft

$4000 > 3873$ **O.K.** 6 x 6 - W2.0 x W2.0 mesh is sufficient.

continued on next page

EXAMPLE PROBLEM

Check Deflection under concentrated load:

$$I_{av} = 6.3 \text{ in}^4/\text{ft}$$

Put load in center of span and use concentrated load coefficients.

$$y = P^3/48EI ; \quad P = 3000(12)/59 = 610 \text{ lbs}$$

$$y = 610(9)^3(1728)/(48 \times 29.5 \times 10^6 \times 6.3) = 0.086 \text{ in.}$$

0.086 in. \leq $l/1250$; Should be **O.K.**

All model building codes require, for some building classifications, the slab to be capable of carrying a 1000 or 2000 lb. load over a 30" x 30" area. The methods shown in this example problem can be used for that particular loading – the footprint of the load would, of course, be larger. This code requirement will probably never be the controlling factor for a steel deck composite slab.

In most cases, building codes or other reference literature will call for a uniform live load. For instance the 2006 IBC calls for offices to be capable of carrying 50 psf, lobbies 100 psf, and corridors 80 psf. These loads can be looked up directly in the Lok-Floor and B-Lok tables since the tables have printed L , the live load, by solving the equation $\phi M_n = (1.6L + 1.2D) l^2 / 8$ for L .

The dead load, D , is taken as the slab and deck weight as shown in the example problem. Although it is possible that some load combination other than $1.6L + 1.2D$ may control, in most cases this combination is critical. For any combination of loading, the ϕM values can be used to calculate the limits.

N-LOK

N Lok is a special version of composite deck. It was originally conceived as a second use for the N tooling to make 3" deep roof deck. Unfortunately the rib dimension of the deck is narrow and the w/h ratio is too low to use it efficiently with shear studs for composite beams. The N Lok properties table is therefore shown for the "no stud" case only. N Lok is particularly useful in applications that use the product as a roof deck with the intention of later ripping off the roof and pouring a floor.

N-LOK Example Problem

For this example the following criteria apply or are taken from the tables:

Gage -	20
Slab Thickness -	5.5 in.
Concrete Density -	145 psf. (normal weight)
$W_{\text{concrete slab}}$ -	40 psf.
W_{deck} -	2.4 psf.
Clear Span -	10 ft. (Maximum unshored span is 11.95 ft. > 10 ft.)
Composite Properties:	
ϕM_{no} -	48.46 in.k
I_{av} -	8.0 in ⁴ /ft
ϕV_{nt} -	3930 lbs. (note this is less than the deck capacity alone, the ultimate shear strength of the concrete controls).
ϕV_n -	5450 lbs. (deck alone)

Assume no negative bending reinforcing steel is used. Determine live load.

Check bending:

Weight of concrete plus deck $W_D = 40 + 2.4 = 42.4$ psf., $W = W_L + W_D$.

$$\phi M_{no} = WL^2/8. \quad \phi M_{no} = \frac{(1.6W_L + 1.2W_D)L^2 \times 12}{8} \quad \text{Solve for } W_L.$$

$$W_L = \frac{[(8 \times 48.46 \text{ in.k/ft.} \times 1000)/(10^2 \text{ ft.}^2 \times 12 \text{ in./ft.})] - 1.2 \times 42.4 \text{ psf.}}{1.6} = 170 \text{ psf.}$$

Check shear:

$$\phi V_n = \frac{(1.6W_L + 1.2W_D)L}{2} \quad \text{Solve for } W_L.$$

$$\begin{aligned} W_L &= \frac{(\phi V_n \times 2 / L) - 1.2 W_D}{1.6} \\ &= \frac{(5450 \text{ lbs./ft.} \times 2 / 10 \text{ ft.}) - 1.2 \times 42.4 \text{ psf.}}{1.6} = 650 \text{ psf.} \end{aligned}$$

$$\text{Check deflection with } \Delta = L/360 = \frac{10 \text{ ft.} \times 12}{360} = 0.33 \text{ in.}$$

$$\Delta = 0.013W_L^4 / EI_{av} \quad \text{Solve for } W_L.$$

$$W_L = EI_{av} \Delta / 0.013 \times L^4 \times 1728$$

$$W_L = 29.5 \times 10^6 \text{ psi.} \times 8.0 \frac{\text{in.}^4}{\text{ft.}} \times 0.33 \text{ in.} / (0.013 \times 10^4 \text{ ft.}^4 \times 1728) = 347 \text{ psf.}$$

Bending controls. The live load allowed is 170 psf.

EXAMPLE PROBLEM



CANAM

Solutions + Service

N-LOK

NO STUDS $F_y = 40 \text{ ksi}$ $f'_c = 3 \text{ ksi}$ **145 and 115 pcf concrete**

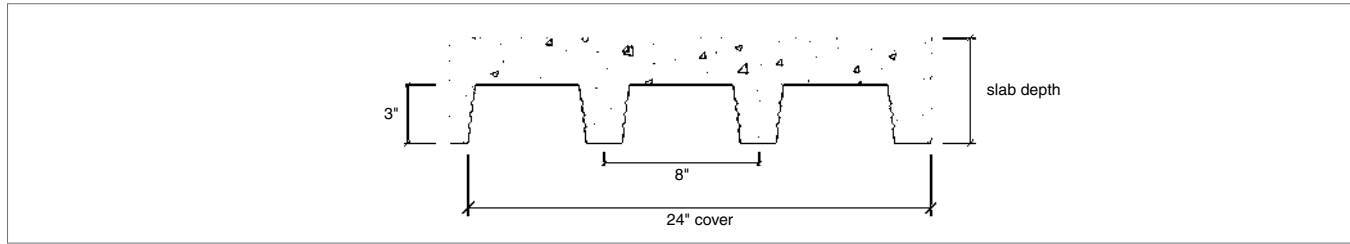

DECK PROPERTIES

Gage	t	w	A _s	I _b	S _b	S _n	φR _{be}	φR _{bi}	φV _n
22	0.0295	2.0	0.587	0.612	0.358	0.401	930	1620	3700
20	0.0358	2.4	0.713	0.785	0.469	0.508	1330	2320	5450
19	0.0418	2.8	0.832	0.965	0.567	0.611	1770	3080	7430
18	0.0474	3.2	0.944	1.144	0.653	0.702	2230	3870	8540
16	0.0598	4.1	1.192	1.558	0.848	0.896	3410	5910	10730

COMPOSITE PROPERTIES

	Slab Depth	A _c in ²	Vol ft ³ /ft ²	A _w in ² /ft	NW Concrete (145 pcf)					Max Unshored spans, ft.			LW Concrete (115 pcf)					Max Unshored spans, ft.		
					W psf	S _c in ³	I _{av} in ⁴	φM _{no} in.k	φV _{nt} lbs.	1 span	2 span	3 span	W psf	S _c in ³	I _{av} in ⁴	φM _{no} in.k	φV _{nt} lbs.	1 span	2 span	3 span
22 gage	5.50	21.1	0.278	0.023	40	1.19	7.4	40.62	3930	7.67	10.27	10.49	32	1.12	5.7	38.22	2950	8.37	11.09	11.40
	6.00	23.6	0.320	0.027	46	1.41	9.7	48.10	4390	7.27	9.78	9.96	37	1.34	7.5	45.40	3290	7.95	10.60	10.85
	6.25	24.9	0.341	0.029	49	1.53	11.0	51.97	4630	7.09	9.56	9.73	39	1.45	8.5	49.14	3470	7.76	10.37	10.60
	6.50	26.2	0.362	0.032	52	1.64	12.5	55.91	4870	6.93	9.35	9.51	42	1.56	9.6	52.95	3650	7.59	10.16	10.38
	7.00	28.8	0.403	0.036	59	1.88	15.8	63.99	5370	6.63	8.97	9.12	46	1.79	12.1	60.80	4030	7.27	9.78	9.96
	7.25	30.2	0.424	0.038	62	2.00	17.6	68.12	5620	6.52	8.80	8.94	49	1.91	13.5	64.81	4220	7.13	9.60	9.78
	7.50	31.6	0.445	0.041	65	2.13	19.6	72.29	5880	6.44	8.63	8.78	51	2.03	15.0	68.88	4410	7.00	9.43	9.60
	8.00	34.4	0.487	0.045	71	2.38	24.1	80.76	6410	6.28	8.33	8.47	56	2.27	18.3	77.15	4810	6.75	9.12	9.28
8.25	35.9	0.508	0.047	74	2.50	26.6	85.05	6690	6.20	8.19	8.33	58	2.39	20.1	81.35	5010	6.64	8.98	9.13	
8.50	37.4	0.528	0.050	77	2.63	29.2	89.38	6960	6.13	8.06	8.20	61	2.52	22.1	85.59	5220	6.54	8.84	8.99	
20 gage	5.50	21.1	0.278	0.023	40	1.43	8.0	48.46	3930	9.01	11.56	11.95	32	1.34	6.2	45.41	2950	9.85	12.47	12.89
	6.00	23.6	0.320	0.027	46	1.69	10.5	57.36	4390	8.52	11.01	11.38	37	1.59	8.2	53.91	3290	9.34	11.92	12.33
	6.25	24.9	0.341	0.029	49	1.82	11.9	61.98	4630	8.31	10.77	11.13	39	1.72	9.3	58.35	3470	9.11	11.68	12.07
	6.50	26.2	0.362	0.032	52	1.96	13.5	66.69	4870	8.11	10.53	10.89	42	1.85	10.4	62.89	3650	8.90	11.44	11.83
	7.00	28.8	0.403	0.036	59	2.25	17.0	76.37	5370	7.76	10.11	10.45	46	2.12	13.1	72.24	4030	8.52	11.01	11.38
	7.25	30.2	0.424	0.038	62	2.39	19.0	81.31	5620	7.62	9.92	10.25	49	2.27	14.6	77.04	4220	8.35	10.82	11.18
	7.50	31.6	0.445	0.041	65	2.54	21.1	86.32	5880	7.52	9.74	10.06	51	2.41	16.3	81.90	4410	8.19	10.63	10.99
	8.00	34.4	0.487	0.045	71	2.84	25.9	96.49	6410	7.33	9.40	9.72	56	2.70	19.9	91.81	4810	7.90	10.28	10.63
8.25	35.9	0.508	0.047	74	2.99	28.5	101.65	6690	7.24	9.25	9.56	58	2.85	21.8	96.85	5010	7.76	10.12	10.46	
8.50	37.4	0.528	0.050	77	3.14	31.3	106.85	6960	7.15	9.10	9.40	61	3.00	23.9	101.93	5220	7.65	9.97	10.30	
19 gage	5.50	21.1	0.278	0.023	40	1.64	8.6	55.78	3930	10.05	12.66	13.09	32	1.53	6.7	52.11	2950	11.02	13.66	14.12
	6.00	23.6	0.320	0.027	46	1.94	11.2	65.98	4390	9.50	12.07	12.47	37	1.82	8.8	61.81	3290	10.43	13.06	13.50
	6.25	24.9	0.341	0.029	49	2.10	12.8	71.28	4630	9.26	11.80	12.20	39	1.97	10.0	66.88	3470	10.17	12.79	13.22
	6.50	26.2	0.362	0.032	52	2.26	14.4	76.70	4870	9.04	11.55	11.94	42	2.12	11.2	72.08	3650	9.93	12.54	12.96
	7.00	28.8	0.403	0.036	59	2.58	18.2	87.85	5370	8.64	11.09	11.46	46	2.44	14.1	82.81	4030	9.51	12.07	12.48
	7.25	30.2	0.424	0.038	62	2.75	20.3	93.55	5620	8.49	10.88	11.25	49	2.60	15.7	88.32	4220	9.31	11.86	12.25
	7.50	31.6	0.445	0.041	65	2.92	22.5	99.32	5880	8.37	10.68	11.04	51	2.76	17.4	93.92	4410	9.13	11.65	12.04
	8.00	34.4	0.487	0.045	71	3.27	27.5	111.07	6410	8.16	10.31	10.66	56	3.10	21.3	105.34	4810	8.80	11.27	11.65
8.25	35.9	0.508	0.047	74	3.44	30.3	117.04	6690	8.06	10.14	10.49	58	3.27	23.4	111.14	5010	8.65	11.10	11.47	
8.50	37.4	0.528	0.050	77	3.62	33.2	123.05	6960	7.96	9.98	10.32	61	3.44	25.6	117.01	5220	8.52	10.93	11.30	
18 gage	5.50	21.1	0.278	0.023	40	1.84	9.1	62.58	3930	10.90	13.55	14.00	32	1.72	7.2	58.33	2950	11.95	14.60	15.09
	6.00	23.6	0.320	0.027	46	2.18	11.9	73.97	4390	10.30	12.91	13.35	37	2.03	9.4	69.10	3290	11.31	13.97	14.44
	6.25	24.9	0.341	0.029	49	2.35	13.5	79.90	4630	10.03	12.63	13.05	39	2.20	10.6	74.75	3470	11.03	13.68	14.14
	6.50	26.2	0.362	0.032	52	2.53	15.3	85.97	4870	9.79	12.36	12.78	42	2.37	12.0	80.55	3650	10.77	13.41	13.86
	7.00	28.8	0.403	0.036	59	2.90	19.2	98.46	5370	9.35	11.87	12.27	46	2.72	15.0	92.55	4030	10.30	12.91	13.35
	7.25	30.2	0.424	0.038	62	3.08	21.4	104.86	5620	9.19	11.65	12.04	49	2.90	16.7	98.72	4220	10.09	12.69	13.11
	7.50	31.6	0.445	0.041	65	3.27	23.8	111.35	5880	9.06	11.44	11.82	51	3.09	18.5	104.99	4410	9.89	12.47	12.89
	8.00	34.4	0.487	0.045	71	3.66	29.0	124.56	6410	8.83	11.04	11.42	56	3.46	22.5	117.79	4810	9.53	12.07	12.47
8.25	35.9	0.508	0.047	74	3.86	31.9	131.27	6690	8.71	10.86	11.23	58	3.66	24.7	124.31	5010	9.36	11.88	12.28	
8.50	37.4	0.528	0.050	77	4.06	35.0	138.04	6960	8.61	10.69	11.05	61	3.85	27.1	130.90	5220	9.22	11.70	12.10	
16 gage	5.50	21.1	0.278	0.023	40	2.27	10.3	62.58	3930	12.61	15.23	15.75	32	2.11	8.2	58.33	2950	13.85	16.40	16.82
	6.00	23.6	0.320	0.027	46	2.68	13.4	73.97	4390	11.91	14.53	15.02	37	2.49	10.6	69.10	3290	13.09	15.70	16.23
	6.25	24.9	0.341	0.029	49	2.90	15.1	79.90	4630	11.60	14.21	14.69	39	2.70	11.9	74.75	3470	12.76	15.38	15.90
	6.50	26.2	0.362	0.032	52	3.12	17.0	85.97	4870	11.31	13.91	14.38	42	2.90	13.4	80.55	3650	12.46	15.08	15.59
	7.00	28.8	0.403	0.036	59	3.57	21.3	98.46	5370	10.80	13.36	13.81	46	3.34	16.8	92.55	4030	11.91	14.53	15.02
	7.25	30.2	0.424	0.038	62	3.80	23.8	104.86	5620	10.61	13.11	13.56	49	3.56	18.7	98.72	4220	11.66	14.27	14.75
	7.50	31.6	0.445	0.041	65	4.04	26.3	111.35	5880	10.46	12.88	13.31	51	3.79	20.7	104.99	4410	11.43	14.03	14.51
	8.00	34.4	0.487	0.045	71	4.52	32.1	124.56	6410	10.19	12.44	12.86	56	4.25	25.1	117.79	4810	11.00	13.58	14.04
8.25	35.9	0.508	0.047	74	4.76	35.3	131.27	6690	10.06	12.24	12.65	58	4.49	27.6	124.31	5010	10.81	13.37	13.83	
8.50	37.4	0.528	0.050	77	5.01	38.6	138.04	6960	9.93	12.05	12.45	61	4.73	30.2	130.90	5220	10.65	13.18	13.62	

Note:
50 ksi material is also available.
See website for load tables.

N-LOK

FLOOR DECK

B-LOK

1.5" x 6" deck $F_y = 40 \text{ ksi}$ $f'_c = 3 \text{ ksi}$ 145 pcf concrete

Studs are not required for composite slab action. Studs on the cross-section indicate that it is possible to install studs at the beams.

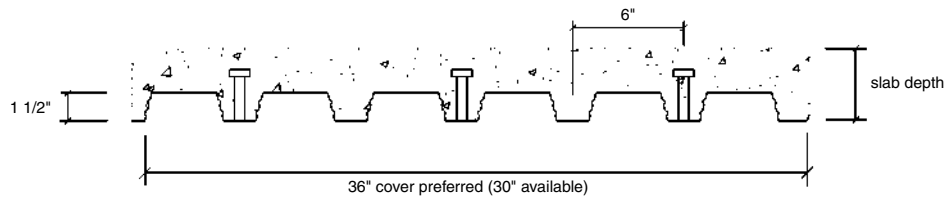

DECK PROPERTIES

Gage	t	w	A_s	I_p	S_p	S_n	ϕR_{be}	ϕR_{bi}	ϕV_n	studs
22	0.0295	1.6	0.470	0.158	0.189	0.191	1290	1690	2830	0.52
20	0.0358	1.9	0.570	0.205	0.233	0.241	1830	2440	3420	0.63
19	0.0418	2.3	0.670	0.251	0.276	0.283	2420	3270	3980	0.74
18	0.0474	2.6	0.760	0.294	0.317	0.322	3040	4140	4500	0.84
16	0.0598	3.3	0.960	0.380	0.406	0.408	4620	6390	5620	0.84

COMPOSITE PROPERTIES

	Slab Depth	ϕM_{nt} in.k	A_c in ²	Vol. ft ³ /ft ²	W psf	S_c in ³	I_{av} in ⁴	ϕM_{no} in.k	ϕV_{nt} lbs.	Max Unshored Span, ft.			A_{wvf} in ² /ft
										1 span	2 span	3 span	
22 gage	4.00	45.43	21.3	0.255	37	0.96	4.0	32.66	3970	5.31	7.10	7.19	0.023
	4.50	53.42	24.8	0.297	43	1.16	5.7	39.48	4610	5.04	6.76	6.84	0.027
	5.00	61.41	28.3	0.339	49	1.37	7.8	46.48	5280	4.81	6.47	6.54	0.032
	5.50	69.40	32.1	0.380	55	1.58	10.4	53.61	5820	4.61	6.21	6.28	0.036
	6.00	77.39	36.0	0.422	61	1.79	13.4	60.83	6180	4.45	5.99	6.06	0.041
	6.50	85.38	40.1	0.464	67	2.00	17.0	68.14	6560	4.34	5.79	5.85	0.045
	6.75	89.37	42.2	0.484	70	2.11	19.1	71.81	6760	4.29	5.69	5.76	0.047
20 gage	4.00	53.83	21.3	0.255	37	1.15	4.3	38.95	3970	6.07	8.14	8.23	0.023
	4.50	63.52	24.8	0.297	43	1.39	6.1	47.11	4610	5.75	7.73	7.82	0.027
	5.00	73.21	28.3	0.339	49	1.63	8.4	55.50	5280	5.48	7.38	7.47	0.032
	5.50	82.90	32.1	0.380	55	1.88	11.1	64.06	5970	5.24	7.08	7.17	0.036
	6.00	92.59	36.0	0.422	61	2.14	14.4	72.76	6700	5.05	6.82	6.90	0.041
	6.50	102.28	40.1	0.464	67	2.40	18.2	81.54	7150	4.93	6.58	6.66	0.045
	6.75	107.12	42.2	0.484	70	2.53	20.4	85.97	7350	4.87	6.48	6.55	0.047
19 gage	4.00	61.78	21.3	0.255	37	1.32	4.6	45.03	3970	6.74	8.89	9.16	0.023
	4.50	73.17	24.8	0.297	43	1.60	6.5	54.51	4610	6.38	8.45	8.69	0.027
	5.00	84.56	28.3	0.339	49	1.89	8.9	64.28	5280	6.07	8.06	8.29	0.032
	5.50	95.95	32.1	0.380	55	2.18	11.8	74.27	5970	5.81	7.72	7.95	0.036
	6.00	107.34	36.0	0.422	61	2.48	15.3	84.41	6700	5.59	7.42	7.65	0.041
	6.50	118.73	40.1	0.464	67	2.78	19.3	94.67	7460	5.45	7.16	7.38	0.045
	6.75	124.43	42.2	0.484	70	2.94	21.6	99.84	7860	5.39	7.03	7.25	0.047
18 gage	4.00	68.56	21.3	0.255	37	1.48	4.9	50.41	3970	7.34	9.47	9.79	0.023
	4.50	81.48	24.8	0.297	43	1.80	6.9	61.06	4610	6.94	9.00	9.30	0.027
	5.00	94.40	28.3	0.339	49	2.12	9.4	72.06	5280	6.60	8.59	8.88	0.032
	5.50	107.32	32.1	0.380	55	2.45	12.4	83.30	5970	6.30	8.23	8.51	0.036
	6.00	120.24	36.0	0.422	61	2.79	16.0	94.73	6700	6.07	7.91	8.18	0.041
	6.50	133.16	40.1	0.464	67	3.13	20.3	106.30	7460	5.91	7.63	7.88	0.045
	6.75	139.62	42.2	0.484	70	3.30	22.6	112.14	7860	5.84	7.50	7.75	0.047
16 gage	4.00	68.56	21.3	0.255	37	1.82	5.4	50.41	3970	8.51	10.62	10.98	0.023
	4.50	81.48	24.8	0.297	43	2.21	7.6	61.06	4610	8.03	10.09	10.43	0.027
	5.00	94.40	28.3	0.339	49	2.61	10.4	72.06	5280	7.63	9.64	9.96	0.032
	5.50	107.32	32.1	0.380	55	3.02	13.7	83.30	5970	7.28	9.24	9.55	0.036
	6.00	120.24	36.0	0.422	61	3.44	17.6	94.73	6700	7.00	8.89	9.19	0.041
	6.50	133.16	40.1	0.464	67	3.87	22.2	106.30	7460	6.82	8.57	8.86	0.045
	6.75	139.62	42.2	0.484	70	4.08	24.8	112.14	7860	6.74	8.42	8.71	0.047
7.00	146.08	44.3	0.505	73	4.30	27.5	117.99	8260	6.65	8.29	8.56	0.050	

Note:
50 ksi material is also available.
See website for load tables.

B-LOK - NW



B-LOK

1.5" x 6" deck $F_y = 40$ ksi $f'_c = 3$ ksi 145 pcf concrete

	Slab Depth	ϕM_n in.k	Span "L" feet, Uniform Live Unfactored Service Loads, psf														
			5.00	5.50	6.00	6.50	7.00	7.50	8.00	8.50	9.00	9.50	10.00	10.50	11.00		
22 gage	4.00	45.43	400	400	400	400	400	355	310	265	235	205	180	160	145	125	
	4.50	53.42	400	400	400	400	400	400	360	315	275	240	215	190	170	150	
	5.00	61.41	400	400	400	400	400	400	400	360	315	280	245	220	195	175	
	5.50	69.40	400	400	400	400	400	400	400	400	360	315	280	245	220	195	
	6.00	77.39	400	400	400	400	400	400	400	400	400	350	310	275	245	220	
	6.50	85.38	400	400	400	400	400	400	400	400	400	400	390	345	305	270	240
	6.75	89.37	400	400	400	400	400	400	400	400	400	400	400	360	320	285	255
	7.00	93.37	400	400	400	400	400	400	400	400	400	400	400	375	335	295	265
20 gage	4.00	53.83	400	400	400	400	400	400	370	320	280	250	220	190	165	140	
	4.50	63.52	400	400	400	400	400	400	400	380	335	295	260	230	205	185	
	5.00	73.21	400	400	400	400	400	400	400	400	385	340	300	265	240	215	
	5.50	82.90	400	400	400	400	400	400	400	400	400	385	340	305	270	245	
	6.00	92.59	400	400	400	400	400	400	400	400	400	400	380	340	305	270	
	6.50	102.28	400	400	400	400	400	400	400	400	400	400	400	375	335	300	
	6.75	107.12	400	400	400	400	400	400	400	400	400	400	400	400	390	350	315
	7.00	111.97	400	400	400	400	400	400	400	400	400	400	400	400	400	365	330
19 gage	4.00	61.78	400	400	400	400	400	400	400	375	325	275	235	200	175	150	
	4.50	73.17	400	400	400	400	400	400	400	400	390	340	305	270	245	215	
	5.00	84.56	400	400	400	400	400	400	400	400	400	395	350	315	280	255	
	5.50	95.95	400	400	400	400	400	400	400	400	400	400	400	355	320	285	
	6.00	107.34	400	400	400	400	400	400	400	400	400	400	400	400	400	360	320
	6.50	118.73	400	400	400	400	400	400	400	400	400	400	400	400	400	395	355
	6.75	124.43	400	400	400	400	400	400	400	400	400	400	400	400	400	400	375
	7.00	130.12	400	400	400	400	400	400	400	400	400	400	400	400	400	400	390
18 gage	4.00	68.56	400	400	400	400	400	400	400	400	350	295	250	215	185	160	
	4.50	81.48	400	400	400	400	400	400	400	400	400	385	340	300	260	225	
	5.00	94.40	400	400	400	400	400	400	400	400	400	400	395	355	320	285	
	5.50	107.32	400	400	400	400	400	400	400	400	400	400	400	400	400	360	325
	6.00	120.24	400	400	400	400	400	400	400	400	400	400	400	400	400	400	365
	6.50	133.16	400	400	400	400	400	400	400	400	400	400	400	400	400	400	400
	6.75	139.62	400	400	400	400	400	400	400	400	400	400	400	400	400	400	400
	7.00	146.08	400	400	400	400	400	400	400	400	400	400	400	400	400	400	400
16 gage	4.00	68.56	400	400	400	400	400	400	400	400	350	295	250	215	185	160	
	4.50	81.48	400	400	400	400	400	400	400	400	400	385	340	300	260	225	
	5.00	94.40	400	400	400	400	400	400	400	400	400	400	395	355	320	285	
	5.50	107.32	400	400	400	400	400	400	400	400	400	400	400	400	400	360	325
	6.00	120.24	400	400	400	400	400	400	400	400	400	400	400	400	400	400	365
	6.50	133.16	400	400	400	400	400	400	400	400	400	400	400	400	400	400	400
	6.75	139.62	400	400	400	400	400	400	400	400	400	400	400	400	400	400	400
	7.00	146.08	400	400	400	400	400	400	400	400	400	400	400	400	400	400	400
22 gage	4.00	32.66	400	400	350	295	250	215	185	160	140	120	105	95	85		
	4.50	39.48	400	400	400	355	300	260	225	195	170	150	130	115	100		
	5.00	46.48	400	400	400	400	355	305	265	230	200	175	155	140	120		
	5.50	53.61	400	400	400	400	400	355	305	265	235	205	180	160	140		
	6.00	60.83	400	400	400	400	400	400	350	305	265	235	205	185	160		
	6.50	68.14	400	400	400	400	400	400	390	340	300	265	230	205	185		
	6.75	71.81	400	400	400	400	400	400	400	360	315	280	245	220	195		
	7.00	75.50	400	400	400	400	400	400	400	380	330	290	260	230	205		
20 gage	4.00	38.95	400	400	400	355	300	260	225	195	170	150	135	120	105		
	4.50	47.11	400	400	400	400	365	315	275	240	210	185	165	145	130		
	5.00	55.50	400	400	400	400	400	375	325	280	245	220	195	170	155		
	5.50	64.06	400	400	400	400	400	400	375	325	285	255	225	200	180		
	6.00	72.76	400	400	400	400	400	400	400	370	325	290	255	230	205		
	6.50	81.54	400	400	400	400	400	400	400	400	370	325	290	255	230		
	6.75	85.97	400	400	400	400	400	400	400	400	390	345	305	270	240		
	7.00	90.41	400	400	400	400	400	400	400	400	400	360	320	285	255		
19 gage	4.00	45.03	400	400	400	400	400	355	305	265	230	200	180	160	140	125	
	4.50	54.51	400	400	400	400	400	400	370	320	280	245	220	195	170	155	
	5.00	64.28	400	400	400	400	400	400	400	380	330	290	260	230	205	185	
	5.50	74.27	400	400	400	400	400	400	400	400	385	340	300	265	240	215	
	6.00	84.41	400	400	400	400	400	400	400	400	400	385	340	305	270	245	
	6.50	94.67	400	400	400	400	400	400	400	400	400	400	385	340	305	275	
	6.75	99.84	400	400	400	400	400	400	400	400	400	400	400	360	325	290	
	7.00	105.03	400	400	400	400	400	400	400	400	400	400	400	380	340	305	
18 gage	4.00	50.41	400	400	400	400	400	400	345	300	260	230	205	180	160	145	
	4.50	61.06	400	400	400	400	400	400	400	365	320	280	250	220	195	175	
	5.00	72.06	400	400	400	400	400	400	400	400	375	330	295	260	235	210	
	5.50	83.30	400	400	400	400	400	400	400	400	400	385	340	305	270	245	
	6.00	94.73	400	400	400	400	400	400	400	400	400	400	390	345	310	280	
	6.50	106.30	400	400	400	400	400	400	400	400	400	400	400	390	350	315	
	6.75	112.14	400	400	400	400	400	400	400	400	400	400	400	400	400	370	330
	7.00	117.99	400	400	400	400	400	400	400	400	400	400	400	400	400	390	350
16 gage	4.00	50.41	400	400	400	400	400	400	345	300	260	230	205	180	160	145	
	4.50	61.06	400	400	400	400	400	400	400	365	320	280	250	220	195	175	
	5.00	72.06	400	400	400	400	400	400	400	400	375	330	295	260	235	210	
	5.50	83.30	400	400	400	400	400	400	400	400	400	385	340	305	270	245	
	6.00	94.73	400	400	400	400	400	400	400	400	400	400	390	345	310	280	
	6.50	106.30	400	400	400	400	400	400	400	400	400	400	400	390	350	315	
	7.00	117.99	400	400	400	400	400	400	400	400	400	400	400	400	390	350	

Studs at 1 foot o.c.

No Studs

INVERTED B-LOK

Inverted 1.5" x 6" deck $F_y = 40 \text{ ksi}$ $f'_c = 3 \text{ ksi}$ 145 pcf concrete

Studs are not required for composite slab action. Studs on the cross-section indicate that it is possible to install studs at the beams.

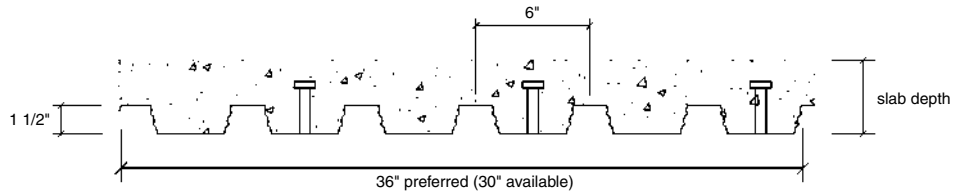

DECK PROPERTIES

Gage	t	w	A _s	I _p	S _p	S _n	φR _{be}	φR _{bi}	φV _n	studs
22	0.0295	1.6	0.470	0.184	0.191	0.189	1290	1690	2830	0.33
20	0.0358	1.9	0.570	0.225	0.241	0.233	1830	2440	3420	0.40
19	0.0418	2.3	0.670	0.264	0.283	0.276	2420	3270	3980	0.47
18	0.0474	2.6	0.760	0.300	0.322	0.317	3040	4140	4500	0.53
16	0.0598	3.3	0.960	0.380	0.408	0.406	4620	6390	5620	0.53

COMPOSITE PROPERTIES

	Slab Depth	φM _{nt} in.k	A _c in ²	Vol. ft ³ /ft ²	W psf	S _c in ³	I _{av} in ⁴	φM _{no} in.k	φV _{nt} lbs.	Max Unshored Span, ft.			A _{wwf} in ² /ft
										1 span	2 span	3 span	
22 gage	4.00	48.62	33.3	0.286	42	1.13	5.1	37.91	5930	5.14	6.89	6.97	0.023
	4.50	56.61	38.3	0.328	48	1.33	7.1	44.93	6390	4.90	6.58	6.66	0.027
	5.00	64.60	43.3	0.370	54	1.54	9.6	52.08	6860	4.69	6.31	6.39	0.032
	5.50	72.59	48.6	0.411	60	1.75	12.5	59.33	7350	4.51	6.08	6.15	0.036
	6.00	80.58	54.0	0.453	66	1.97	16.0	66.66	7860	4.39	5.87	5.94	0.041
	6.50	88.57	59.6	0.495	72	2.18	20.1	74.04	8380	4.29	5.69	5.75	0.045
	6.75	92.57	62.4	0.516	75	2.29	22.3	77.75	8640	4.25	5.60	5.67	0.047
20 gage	4.00	57.70	33.3	0.286	42	1.34	5.5	45.32	6210	5.95	7.77	8.03	0.023
	4.50	67.39	38.3	0.328	48	1.59	7.6	53.74	6980	5.66	7.41	7.66	0.027
	5.00	77.08	43.3	0.370	54	1.84	10.2	62.32	7450	5.41	7.09	7.33	0.032
	5.50	86.77	48.6	0.411	60	2.09	13.3	71.04	7940	5.19	6.81	7.04	0.036
	6.00	96.46	54.0	0.453	66	2.35	17.0	79.85	8450	5.06	6.56	6.78	0.041
	6.50	106.15	59.6	0.495	72	2.61	21.3	88.74	8970	4.94	6.33	6.54	0.045
	6.75	111.00	62.4	0.516	75	2.75	23.7	93.21	9230	4.88	6.23	6.44	0.047
19 gage	4.00	66.34	33.3	0.286	42	1.55	5.8	52.53	6210	6.56	8.45	8.73	0.023
	4.50	77.73	38.3	0.328	48	1.84	8.1	62.32	7120	6.24	8.05	8.32	0.027
	5.00	89.12	43.3	0.370	54	2.13	10.8	72.33	8010	5.96	7.71	7.97	0.032
	5.50	100.51	48.6	0.411	60	2.43	14.1	82.49	8500	5.72	7.40	7.65	0.036
	6.00	111.90	54.0	0.453	66	2.73	17.9	92.78	9010	5.57	7.13	7.37	0.041
	6.50	123.29	59.6	0.495	72	3.04	22.4	103.17	9530	5.43	6.89	7.12	0.045
	6.75	128.98	62.4	0.516	75	3.19	24.9	108.39	9790	5.37	6.78	7.00	0.047
18 gage	4.00	73.73	33.3	0.286	42	1.74	6.1	58.93	6210	7.10	9.04	9.34	0.023
	4.50	86.65	38.3	0.328	48	2.06	8.4	69.94	7120	6.74	8.62	8.91	0.027
	5.00	99.57	43.3	0.370	54	2.39	11.3	81.20	8070	6.43	8.25	8.53	0.032
	5.50	112.49	48.6	0.411	60	2.73	14.7	92.66	9020	6.17	7.93	8.19	0.036
	6.00	125.41	54.0	0.453	66	3.07	18.8	104.27	9530	6.01	7.64	7.89	0.041
	6.50	138.33	59.6	0.495	72	3.41	23.4	115.98	10050	5.86	7.38	7.63	0.045
	6.75	144.79	62.4	0.516	75	3.59	26.0	121.88	10310	5.79	7.26	7.50	0.047
16 gage	4.00	73.73	33.3	0.286	42	2.13	6.7	58.93	6210	8.16	10.19	10.54	0.023
	4.50	86.65	38.3	0.328	48	2.54	9.2	69.94	7120	7.74	9.72	10.05	0.027
	5.00	99.57	43.3	0.370	54	2.95	12.4	81.20	8070	7.39	9.31	9.63	0.032
	5.50	112.49	48.6	0.411	60	3.37	16.1	92.66	9050	7.08	8.95	9.25	0.036
	6.00	125.41	54.0	0.453	66	3.80	20.4	104.27	10060	6.89	8.63	8.92	0.041
	6.50	138.33	59.6	0.495	72	4.23	25.5	115.98	11100	6.71	8.33	8.61	0.045
	6.75	144.79	62.4	0.516	75	4.44	28.3	121.88	11430	6.63	8.20	8.47	0.047
	7.00	151.25	65.3	0.536	78	4.66	31.3	127.79	11700	6.56	8.07	8.34	0.050

Note:
50 ksi material is also available.
See website for load tables.

INVERTED B-LOK - NW

FLOOR DECK



INVERTED B-LOK

1.5" x 6" deck $F_y = 40$ ksi $f'_c = 3$ ksi 145 pcf concrete

	Slab Depth	ϕM_n in.k	Span "L" feet, Uniform Live Unfactored Service Loads, psf													
			5.00	5.50	6.00	6.50	7.00	7.50	8.00	8.50	9.00	9.50	10.00	10.50	11.00	
22 gage	4.00	48.62	400	400	400	400	400	380	330	285	250	220	190	170	150	135
	4.50	56.61	400	400	400	400	400	380	330	290	255	225	200	175	160	
	5.00	64.60	400	400	400	400	400	400	380	330	290	255	230	205	180	
	5.50	72.59	400	400	400	400	400	400	400	375	325	290	255	230	205	
	6.00	80.58	400	400	400	400	400	400	400	400	365	320	285	255	225	
	6.50	88.57	400	400	400	400	400	400	400	400	400	355	315	280	250	
	6.75	92.57	400	400	400	400	400	400	400	400	400	400	370	330	295	260
	7.00	96.56	400	400	400	400	400	400	400	400	400	400	385	345	305	275
20 gage	4.00	57.70	400	400	400	400	400	395	345	300	265	235	210	185	165	
	4.50	67.39	400	400	400	400	400	400	400	350	310	275	245	220	195	
	5.00	77.08	400	400	400	400	400	400	400	400	355	315	280	250	225	
	5.50	86.77	400	400	400	400	400	400	400	400	400	355	315	280	255	
	6.00	96.46	400	400	400	400	400	400	400	400	400	395	350	315	280	
	6.50	106.15	400	400	400	400	400	400	400	400	400	400	385	345	310	
	6.75	111.00	400	400	400	400	400	400	400	400	400	400	400	400	360	325
	7.00	115.84	400	400	400	400	400	400	400	400	400	400	400	400	380	340
19 gage	4.00	66.34	400	400	400	400	400	400	400	350	310	275	245	220	190	
	4.50	77.73	400	400	400	400	400	400	400	400	360	320	285	255	230	
	5.00	89.12	400	400	400	400	400	400	400	400	400	370	330	295	265	
	5.50	100.51	400	400	400	400	400	400	400	400	400	400	370	335	300	
	6.00	111.90	400	400	400	400	400	400	400	400	400	400	400	400	370	335
	6.50	123.29	400	400	400	400	400	400	400	400	400	400	400	400	400	370
	6.75	128.98	400	400	400	400	400	400	400	400	400	400	400	400	400	385
	7.00	134.68	400	400	400	400	400	400	400	400	400	400	400	400	400	400
18 gage	4.00	73.73	400	400	400	400	400	400	400	390	345	305	265	230	200	
	4.50	86.65	400	400	400	400	400	400	400	400	400	360	325	290	260	
	5.00	99.57	400	400	400	400	400	400	400	400	400	400	375	335	300	
	5.50	112.49	400	400	400	400	400	400	400	400	400	400	400	400	380	340
	6.00	125.41	400	400	400	400	400	400	400	400	400	400	400	400	400	380
	6.50	138.33	400	400	400	400	400	400	400	400	400	400	400	400	400	400
	6.75	144.79	400	400	400	400	400	400	400	400	400	400	400	400	400	400
	7.00	151.25	400	400	400	400	400	400	400	400	400	400	400	400	400	400
16 gage	4.00	73.73	400	400	400	400	400	400	400	390	345	305	265	230	200	
	4.50	86.65	400	400	400	400	400	400	400	400	400	360	325	290	260	
	5.00	99.57	400	400	400	400	400	400	400	400	400	400	375	335	300	
	5.50	112.49	400	400	400	400	400	400	400	400	400	400	400	400	380	340
	6.00	125.41	400	400	400	400	400	400	400	400	400	400	400	400	400	380
	6.50	138.33	400	400	400	400	400	400	400	400	400	400	400	400	400	400
	6.75	144.79	400	400	400	400	400	400	400	400	400	400	400	400	400	400
	7.00	151.25	400	400	400	400	400	400	400	400	400	400	400	400	400	400
22 gage	4.00	37.91	400	400	400	340	290	250	215	185	165	145	125	110	100	
	4.50	44.93	400	400	400	400	345	295	255	220	195	170	150	135	120	
	5.00	52.08	400	400	400	400	400	345	300	260	225	200	175	155	140	
	5.50	59.33	400	400	400	400	400	395	340	295	260	230	200	180	160	
	6.00	66.66	400	400	400	400	400	400	385	335	290	255	225	200	180	
	6.50	74.04	400	400	400	400	400	400	400	370	325	285	255	225	200	
	6.75	77.75	400	400	400	400	400	400	400	390	345	300	265	235	210	
	7.00	81.47	400	400	400	400	400	400	400	400	360	315	280	250	220	
20 gage	4.00	45.32	400	400	400	400	355	305	260	230	200	175	155	140	125	
	4.50	53.74	400	400	400	400	400	360	315	275	240	210	185	165	150	
	5.00	62.32	400	400	400	400	400	400	365	320	280	245	220	195	175	
	5.50	71.04	400	400	400	400	400	400	400	365	320	280	250	220	200	
	6.00	79.85	400	400	400	400	400	400	400	400	360	320	280	250	225	
	6.50	88.74	400	400	400	400	400	400	400	400	400	355	315	280	250	
	6.75	93.21	400	400	400	400	400	400	400	400	400	375	330	295	265	
	7.00	97.69	400	400	400	400	400	400	400	400	400	390	345	310	275	
19 gage	4.00	52.53	400	400	400	400	400	355	310	270	235	210	185	165	150	
	4.50	62.32	400	400	400	400	400	400	370	320	285	250	220	200	175	
	5.00	72.33	400	400	400	400	400	400	400	375	330	290	260	230	205	
	5.50	82.49	400	400	400	400	400	400	400	400	380	335	295	265	240	
	6.00	92.78	400	400	400	400	400	400	400	400	400	375	335	300	270	
	6.50	103.17	400	400	400	400	400	400	400	400	400	400	375	335	300	
	6.75	108.39	400	400	400	400	400	400	400	400	400	400	395	350	315	
	7.00	113.63	400	400	400	400	400	400	400	400	400	400	400	370	330	
18 gage	4.00	58.93	400	400	400	400	400	400	350	305	270	240	210	190	170	
	4.50	69.94	400	400	400	400	400	400	400	365	320	285	255	225	205	
	5.00	81.20	400	400	400	400	400	400	400	400	375	335	295	265	235	
	5.50	92.66	400	400	400	400	400	400	400	400	400	380	340	305	270	
	6.00	104.27	400	400	400	400	400	400	400	400	400	400	385	345	310	
	6.50	115.98	400	400	400	400	400	400	400	400	400	400	400	385	345	
	6.75	121.88	400	400	400	400	400	400	400	400	400	400	400	400	400	360
	7.00	127.79	400	400	400	400	400	400	400	400	400	400	400	400	400	380
16 gage	4.00	58.93	400	400	400	400	400	400	350	305	270	240	210	190	170	
	4.50	69.94	400	400	400	400	400	400	400	365	320	285	255	225	205	
	5.00	81.20	400	400	400	400	400	400	400	400	375	335	295	265	235	
	5.50	92.66	400	400	400	400	400	400	400	400	400	380	340	305	270	
	6.00	104.27	400	400	400	400	400	400	400	400	400	400	385	345	310	
	6.50	115.98	400	400	400	400	400	400	400	400	400	400	400	385	345	
	6.75	121.88	400	400	400	400	400	400	400	400	400	400	400	400	400	360
	7.00	127.79	400	400	400	400	400	400	400	400	400	400	400	400	400	380

Studs at 1 foot o.c.

No Studs

1.5" LOK-FLOOR

1.5" x 12" deck $F_y = 40 \text{ ksi}$ $f'_c = 3 \text{ ksi}$ 145 pcf concrete

Studs are not required for composite slab action. Studs on the cross-section indicate that it is possible to install studs at the beams.

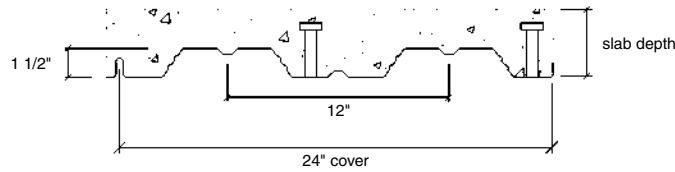

DECK PROPERTIES

Gage	t	w	A_s	I_p	S_p	S_n	ϕR_{be}	ϕR_{bi}	ϕV_n	studs
22	0.0295	1.5	0.430	0.177	0.187	0.196	550	910	1860	0.43
20	0.0358	1.8	0.520	0.225	0.249	0.258	780	1300	2250	0.53
19	0.0418	2.1	0.610	0.262	0.311	0.319	1040	1730	2620	0.61
18	0.0474	2.3	0.690	0.298	0.361	0.371	1310	2170	2970	0.70
16	0.0598	3.0	0.870	0.376	0.469	0.469	1990	3310	3730	0.70

COMPOSITE PROPERTIES

	Slab Depth	ϕM_{nt} in.k	A_c in ²	Vol. ft ³ /ft ²	W psf	S_c in ³	I_{av} in ⁴	ϕM_{no} in.k	ϕV_{nt} lbs.	Max Unshored Span, ft.			A_{wvf} in ² /ft
										1 span	2 span	3 span	
22 gage	4.00	43.41	30.7	0.271	39	0.97	4.4	33.08	4720	5.17	6.92	7.01	0.023
	4.50	50.72	36.0	0.313	45	1.15	6.2	39.37	5210	4.92	6.60	6.68	0.027
	5.00	58.03	41.7	0.354	51	1.34	8.4	45.82	5740	4.70	6.33	6.40	0.032
	5.50	65.34	47.0	0.396	57	1.54	11.1	52.38	6240	4.51	5.98	6.16	0.036
	6.00	72.65	51.8	0.438	63	1.73	14.3	59.02	6680	4.38	5.42	5.65	0.041
	6.50	79.96	56.5	0.479	69	1.93	18.0	65.72	7120	4.23	4.96	5.17	0.045
	6.75	83.61	58.9	0.500	73	2.03	20.1	69.10	7340	4.10	4.76	4.95	0.047
20 gage	4.00	51.45	30.7	0.271	39	1.15	4.7	39.41	5110	6.20	8.29	8.43	0.023
	4.50	60.29	36.0	0.313	45	1.38	6.7	46.93	5600	5.88	7.88	8.02	0.027
	5.00	69.13	41.7	0.354	51	1.60	9.0	54.65	6130	5.61	7.52	7.67	0.032
	5.50	77.97	47.0	0.396	57	1.83	11.8	62.51	6630	5.38	7.21	7.37	0.036
	6.00	86.81	51.8	0.438	63	2.07	15.2	70.48	7070	5.21	6.93	7.10	0.041
	6.50	95.65	56.5	0.479	69	2.31	19.2	78.54	7510	5.09	6.68	6.86	0.045
	6.75	100.07	58.9	0.500	73	2.43	21.4	82.59	7730	5.03	6.57	6.75	0.047
19 gage	4.00	59.14	30.7	0.271	39	1.33	5.0	45.50	5480	7.11	9.21	9.51	0.023
	4.50	69.51	36.0	0.313	45	1.59	7.1	54.24	5970	6.74	8.75	9.05	0.027
	5.00	79.88	41.7	0.354	51	1.85	9.5	63.23	6500	6.42	8.36	8.64	0.032
	5.50	90.25	47.0	0.396	57	2.12	12.5	72.39	7000	6.15	8.01	8.28	0.036
	6.00	100.62	51.8	0.438	63	2.40	16.1	81.68	7440	5.95	7.71	7.96	0.041
	6.50	110.99	56.5	0.479	69	2.67	20.2	91.08	7880	5.80	7.43	7.68	0.045
	6.75	116.17	58.9	0.500	73	2.81	22.5	95.81	8100	5.73	7.30	7.55	0.047
18 gage	4.00	65.67	30.7	0.271	39	1.49	5.3	50.78	5710	7.78	9.92	10.25	0.023
	4.50	77.40	36.0	0.313	45	1.77	7.4	60.60	6320	7.37	9.44	9.75	0.027
	5.00	89.13	41.7	0.354	51	2.07	10.0	70.70	6850	7.01	9.01	9.31	0.032
	5.50	100.86	47.0	0.396	57	2.38	13.1	81.00	7350	6.71	8.64	8.93	0.036
	6.00	112.59	51.8	0.438	63	2.68	16.8	91.46	7790	6.49	8.31	8.59	0.041
	6.50	124.32	56.5	0.479	69	3.00	21.1	102.04	8230	6.33	8.02	8.28	0.045
	6.75	130.18	58.9	0.500	73	3.15	23.5	107.37	8450	6.25	7.88	8.14	0.047
16 gage	4.00	65.67	30.7	0.271	39	1.82	5.8	50.78	5710	9.08	11.13	11.34	0.023
	4.50	77.40	36.0	0.313	45	2.18	8.1	60.60	6700	8.58	10.59	10.87	0.027
	5.00	89.13	41.7	0.354	51	2.55	10.9	70.70	7610	8.16	10.13	10.45	0.032
	5.50	100.86	47.0	0.396	57	2.93	14.3	81.00	8110	7.80	9.71	10.04	0.036
	6.00	112.59	51.8	0.438	63	3.32	18.3	91.46	8550	7.54	9.35	9.66	0.041
	6.50	124.32	56.5	0.479	69	3.71	23.0	102.04	8990	7.35	9.02	9.32	0.045
	6.75	130.18	58.9	0.500	73	3.90	25.6	107.37	9210	7.26	8.86	9.16	0.047
	7.00	136.05	61.3	0.521	76	4.10	28.3	112.72	9430	7.17	8.72	9.01	0.050

Note:
50 ksi material is also available.
See website for load tables.

1.5" LOK-FLOOR - NW



1.5" LOK-FLOOR

1.5" x 12" deck $F_y = 40$ ksi $f'_c = 3$ ksi 145 pcf concrete

	Slab Depth	ϕM_n in.k	Span "L" feet, Uniform Live Unfactored Service Loads, psf													
			5.00	5.50	6.00	6.50	7.00	7.50	8.00	8.50	9.00	9.50	10.00	10.50	11.00	
22 gage	4.00	43.41	400	400	400	400	400	340	290	250	220	195	170	150	135	120
	4.50	50.72	400	400	400	400	400	395	340	295	255	225	200	175	155	140
	5.00	58.03	400	400	400	400	400	400	400	390	340	295	260	230	200	180
	5.50	65.34	400	400	400	400	400	400	400	400	380	335	290	260	230	205
	6.00	72.65	400	400	400	400	400	400	400	400	400	370	325	285	255	225
	6.50	79.96	400	400	400	400	400	400	400	400	400	400	360	315	280	250
	6.75	83.61	400	400	400	400	400	400	400	400	400	400	375	330	295	260
	7.00	87.27	400	400	400	400	400	400	400	400	400	400	390	345	305	270
20 gage	4.00	51.45	400	400	400	400	400	400	350	305	265	235	205	185	165	145
	4.50	60.29	400	400	400	400	400	400	400	355	310	275	245	215	195	170
	5.00	69.13	400	400	400	400	400	400	400	400	360	315	280	250	220	200
	5.50	77.97	400	400	400	400	400	400	400	400	400	355	315	280	250	225
	6.00	86.81	400	400	400	400	400	400	400	400	400	400	350	315	280	250
	6.50	95.65	400	400	400	400	400	400	400	400	400	400	400	390	345	310
	6.75	100.07	400	400	400	400	400	400	400	400	400	400	400	400	360	320
	7.00	104.49	400	400	400	400	400	400	400	400	400	400	400	400	375	335
19 gage	4.00	59.14	400	400	400	400	400	400	400	355	310	275	240	215	190	165
	4.50	69.51	400	400	400	400	400	400	400	400	365	320	285	255	225	205
	5.00	79.88	400	400	400	400	400	400	400	400	400	370	330	295	260	235
	5.50	90.25	400	400	400	400	400	400	400	400	400	400	370	330	295	265
	6.00	100.62	400	400	400	400	400	400	400	400	400	400	400	370	330	295
	6.50	110.99	400	400	400	400	400	400	400	400	400	400	400	400	365	330
	6.75	116.17	400	400	400	400	400	400	400	400	400	400	400	400	385	345
	7.00	121.36	400	400	400	400	400	400	400	400	400	400	400	400	400	360
18 gage	4.00	65.67	400	400	400	400	400	400	400	395	345	305	270	235	200	175
	4.50	77.40	400	400	400	400	400	400	400	400	400	360	320	285	255	230
	5.00	89.13	400	400	400	400	400	400	400	400	400	400	370	330	295	265
	5.50	100.86	400	400	400	400	400	400	400	400	400	400	400	375	335	300
	6.00	112.59	400	400	400	400	400	400	400	400	400	400	400	400	375	340
	6.50	124.32	400	400	400	400	400	400	400	400	400	400	400	400	400	375
	6.75	130.18	400	400	400	400	400	400	400	400	400	400	400	400	400	390
	7.00	136.05	400	400	400	400	400	400	400	400	400	400	400	400	400	400
16 gage	4.00	65.67	400	400	400	400	400	400	400	395	345	305	270	235	200	175
	4.50	77.40	400	400	400	400	400	400	400	400	400	360	320	285	255	230
	5.00	89.13	400	400	400	400	400	400	400	400	400	400	370	330	295	265
	5.50	100.86	400	400	400	400	400	400	400	400	400	400	400	375	335	300
	6.00	112.59	400	400	400	400	400	400	400	400	400	400	400	400	375	340
	6.50	124.32	400	400	400	400	400	400	400	400	400	400	400	400	400	375
	6.75	130.18	400	400	400	400	400	400	400	400	400	400	400	400	400	390
	7.00	136.05	400	400	400	400	400	400	400	400	400	400	400	400	400	400
22 gage	4.00	33.08	400	400	350	295	250	215	185	160	140	120	105	95	85	
	4.50	39.37	400	400	400	355	300	255	220	190	165	145	130	115	100	
	5.00	45.82	400	400	400	400	350	300	260	225	195	170	150	135	120	
	5.50	52.38	400	400	400	400	400	345	295	260	225	200	175	155	135	
	6.00	59.02	400	400	400	400	400	400	390	335	290	255	225	195	175	155
	6.50	65.72	400	400	400	400	400	400	400	375	325	285	250	220	195	175
	6.75	69.10	400	400	400	400	400	400	400	395	345	300	265	230	205	180
	7.00	72.48	400	400	400	400	400	400	400	400	360	315	275	245	215	190
20 gage	4.00	39.41	400	400	400	360	305	260	225	195	170	150	135	120	105	
	4.50	46.93	400	400	400	400	365	310	270	235	205	180	160	140	125	
	5.00	54.65	400	400	400	400	400	365	315	275	240	210	190	165	150	
	5.50	62.51	400	400	400	400	400	400	365	315	275	245	215	190	170	
	6.00	70.48	400	400	400	400	400	400	400	360	315	275	245	215	195	
	6.50	78.54	400	400	400	400	400	400	400	400	350	310	275	245	215	
	6.75	82.59	400	400	400	400	400	400	400	400	370	325	290	255	230	
	7.00	86.66	400	400	400	400	400	400	400	400	390	340	305	270	240	
19 gage	4.00	45.50	400	400	400	400	355	305	265	230	205	180	160	140	125	
	4.50	54.24	400	400	400	400	400	365	320	275	245	215	190	170	150	
	5.00	63.23	400	400	400	400	400	400	370	325	285	250	225	200	180	
	5.50	72.39	400	400	400	400	400	400	400	375	330	290	255	230	205	
	6.00	81.68	400	400	400	400	400	400	400	400	370	330	290	260	230	
	6.50	91.08	400	400	400	400	400	400	400	400	400	365	325	290	260	
	6.75	95.81	400	400	400	400	400	400	400	400	400	385	345	305	275	
	7.00	100.56	400	400	400	400	400	400	400	400	400	400	360	320	290	
18 gage	4.00	50.78	400	400	400	400	400	345	300	260	230	205	180	160	145	
	4.50	60.60	400	400	400	400	400	400	360	315	275	245	215	195	175	
	5.00	70.70	400	400	400	400	400	400	400	365	325	285	255	225	205	
	5.50	81.00	400	400	400	400	400	400	400	400	370	330	295	260	235	
	6.00	91.46	400	400	400	400	400	400	400	400	400	375	330	295	265	
	6.50	102.04	400	400	400	400	400	400	400	400	400	400	370	330	300	
	6.75	107.37	400	400	400	400	400	400	400	400	400	400	400	390	350	315
	7.00	112.72	400	400	400	400	400	400	400	400	400	400	400	400	370	330
16 gage	4.00	50.78	400	400	400	400	400	345	300	260	230	205	180	160	145	
	4.50	60.60	400	400	400	400	400	400	360	315	275	245	215	195	175	
	5.00	70.70	400	400	400	400	400	400	400	365	325	285	255	225	205	
	5.50	81.00	400	400	400	400	400	400	400	400	370	330	295	260	235	
	6.00	91.46	400	400	400	400	400	400	400	400	400	375	330	295	265	
	6.50	102.04	400	400	400	400	400	400	400	400	400	400	370	330	300	
	6.75	107.37	400	400	400	400	400	400	400	400	400	400	400	390	350	315
	7.00	112.72	400	400	400	400	400	400	400	400	400	400	400	400	370	330

Studs at 1 foot o.c.

No Studs

2" LOK-FLOOR

2" x 12" deck $F_y = 40 \text{ ksi}$ $f'_c = 3 \text{ ksi}$ 145 pcf concrete

Studs are not required for composite slab action. Studs on the cross-section indicate that it is possible to install studs at the beams.

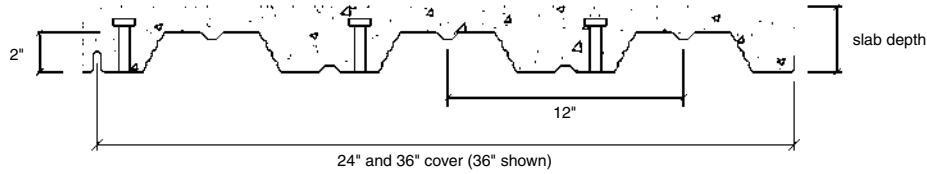

DECK PROPERTIES

Gage	t	w	A_s	I_p	S_p	S_n	ϕR_{be}	ϕR_{bi}	ϕV_n	studs
22	0.0295	1.5	0.440	0.312	0.251	0.262	700	1190	2160	0.43
20	0.0358	1.8	0.540	0.390	0.332	0.345	800	1360	2930	0.53
19	0.0418	2.1	0.630	0.455	0.413	0.424	1060	1800	3410	0.61
18	0.0474	2.4	0.710	0.517	0.480	0.483	1340	2270	3860	0.70
16	0.0598	3.1	0.900	0.653	0.611	0.611	2040	3460	4860	0.70

COMPOSITE PROPERTIES

	Slab Depth	ϕM_{nt} in.k	A_c in ²	Vol. ft ³ /ft ²	W psf	S_c in ³	I_{av} in ⁴	ϕM_{no} in.k	ϕV_{nt} lbs.	Max Unshored Span, ft.			A_{wvf} in ² /ft
										1 span	2 span	3 span	
22 gage	4.50	48.06	32.6	0.292	42	1.04	5.9	35.55	5200	6.07	8.14	8.28	0.023
	5.00	55.54	37.5	0.333	48	1.22	8.0	41.78	5650	5.78	7.76	7.89	0.027
	5.50	63.02	42.6	0.375	54	1.41	10.5	48.19	6130	5.52	7.42	7.56	0.032
	6.00	70.50	48.0	0.417	60	1.61	13.5	54.74	6630	5.31	7.12	7.27	0.036
	6.50	77.98	53.6	0.458	66	1.80	17.1	61.40	7150	5.18	6.85	7.02	0.041
	7.00	85.46	59.5	0.500	73	2.00	21.2	68.15	7700	5.05	6.53	6.79	0.045
	7.25	89.20	61.9	0.521	76	2.10	23.5	71.55	7920	5.00	6.32	6.58	0.047
20 gage	4.50	57.78	32.6	0.292	42	1.25	6.3	42.94	5970	7.21	9.36	9.67	0.023
	5.00	66.96	37.5	0.333	48	1.48	8.5	50.48	6420	6.84	8.92	9.22	0.027
	5.50	76.14	42.6	0.375	54	1.71	11.2	58.25	6900	6.53	8.54	8.82	0.032
	6.00	85.32	48.0	0.417	60	1.94	14.4	66.21	7400	6.27	8.20	8.47	0.036
	6.50	94.50	53.6	0.458	66	2.18	18.2	74.31	7920	6.11	7.89	8.16	0.041
	7.00	103.68	59.5	0.500	73	2.42	22.6	82.52	8470	5.96	7.44	7.75	0.045
	7.25	108.27	61.9	0.521	76	2.54	25.0	86.66	8690	5.89	7.20	7.50	0.047
19 gage	4.50	66.15	32.6	0.292	42	1.44	6.7	49.32	6080	8.21	10.36	10.71	0.023
	5.00	76.86	37.5	0.333	48	1.70	9.0	58.03	6900	7.79	9.88	10.21	0.027
	5.50	87.57	42.6	0.375	54	1.96	11.8	67.03	7380	7.43	9.46	9.77	0.032
	6.00	98.28	48.0	0.417	60	2.23	15.2	76.25	7880	7.12	9.08	9.39	0.036
	6.50	108.99	53.6	0.458	66	2.51	19.2	85.63	8400	6.94	8.75	9.04	0.041
	7.00	119.70	59.5	0.500	73	2.79	23.7	95.15	8950	6.76	8.45	8.73	0.045
	7.25	125.06	61.9	0.521	76	2.93	26.3	99.96	9170	6.68	8.31	8.58	0.047
18 gage	4.50	73.29	32.6	0.292	42	1.60	7.0	54.96	6080	8.97	11.05	11.42	0.023
	5.00	85.36	37.5	0.333	48	1.89	9.4	64.68	6980	8.50	10.54	10.89	0.027
	5.50	97.43	42.6	0.375	54	2.19	12.4	74.74	7830	8.10	10.09	10.43	0.032
	6.00	109.50	48.0	0.417	60	2.49	15.9	85.06	8330	7.77	9.69	10.02	0.036
	6.50	121.57	53.6	0.458	66	2.80	20.0	95.58	8850	7.56	9.34	9.65	0.041
	7.00	133.64	59.5	0.500	73	3.12	24.7	106.25	9400	7.37	9.02	9.32	0.045
	7.25	139.67	61.9	0.521	76	3.28	27.3	111.64	9620	7.28	8.87	9.17	0.047
16 gage	4.50	73.29	32.6	0.292	42	1.97	7.7	54.96	6080	10.30	12.40	12.79	0.023
	5.00	85.36	37.5	0.333	48	2.33	10.3	64.68	6980	9.75	11.83	12.23	0.027
	5.50	97.43	42.6	0.375	54	2.70	13.5	74.74	7940	9.29	11.58	11.71	0.032
	6.00	109.50	48.0	0.417	60	3.08	17.3	85.06	8940	8.90	10.89	11.26	0.036
	6.50	121.57	53.6	0.458	66	3.47	21.8	95.58	9850	8.66	10.50	10.85	0.041
	7.00	133.64	59.5	0.500	73	3.87	26.9	106.25	10400	8.44	10.14	10.48	0.045
	7.25	139.67	61.9	0.521	76	4.07	29.8	111.64	10620	8.33	9.98	10.31	0.047
	7.50	145.71	64.3	0.542	79	4.27	32.8	117.05	10840	8.23	9.82	10.15	0.050

Note:
50 ksi material is also available.
See website for load tables.

2" LOK-FLOOR - NW



2" LOK-FLOOR

2" x 12" deck $F_y = 40$ ksi $f'_c = 3$ ksi 145 pcf concrete

	Slab Depth	ϕM_n in.k	Span "L" feet, Uniform Live Unfactored Service Loads, psf													
			6.00	6.50	7.00	7.50	8.00	8.50	9.00	9.50	10.00	10.50	11.00	11.50	12.00	
22 gage	4.50	48.06	400	400	375	325	280	245	215	190	165	150	135	120	105	
	5.00	55.54	400	400	400	375	325	285	250	220	195	175	155	140	125	
	5.50	63.02	400	400	400	400	370	320	280	250	220	195	175	155	140	
	6.00	70.50	400	400	400	400	400	360	315	280	245	220	195	175	160	
	6.50	77.98	400	400	400	400	400	400	350	310	275	245	220	195	175	
	7.00	85.46	400	400	400	400	400	400	385	340	300	265	240	215	190	
	7.25	89.20	400	400	400	400	400	400	400	355	315	280	250	225	200	
	7.50	92.94	400	400	400	400	400	400	400	370	325	290	260	235	210	
20 gage	4.50	57.78	400	400	400	395	345	300	265	235	210	185	165	150	135	
	5.00	66.96	400	400	400	400	400	350	305	270	240	215	195	175	155	
	5.50	76.14	400	400	400	400	400	395	350	310	275	245	220	200	180	
	6.00	85.32	400	400	400	400	400	400	390	345	310	275	245	220	200	
	6.50	94.50	400	400	400	400	400	400	400	385	345	305	275	245	220	
	7.00	103.68	400	400	400	400	400	400	400	400	375	335	300	270	245	
	7.25	108.27	400	400	400	400	400	400	400	400	395	350	315	285	255	
	7.50	112.86	400	400	400	400	400	400	400	400	400	365	330	295	265	
19 gage	4.50	66.15	400	400	400	400	395	350	305	270	240	215	195	175	160	
	5.00	76.86	400	400	400	400	400	400	360	315	280	255	225	205	185	
	5.50	87.57	400	400	400	400	400	400	400	360	320	290	260	235	210	
	6.00	98.28	400	400	400	400	400	400	400	400	365	325	290	265	235	
	6.50	108.99	400	400	400	400	400	400	400	400	400	360	325	290	265	
	7.00	119.70	400	400	400	400	400	400	400	400	400	395	355	320	290	
	7.25	125.06	400	400	400	400	400	400	400	400	400	400	370	335	305	
	7.50	130.41	400	400	400	400	400	400	400	400	400	400	390	350	315	
18 gage	4.50	73.29	400	400	400	400	400	390	345	305	270	245	220	195	180	
	5.00	85.36	400	400	400	400	400	400	400	355	320	285	255	230	210	
	5.50	97.43	400	400	400	400	400	400	400	400	365	325	295	265	240	
	6.00	109.50	400	400	400	400	400	400	400	400	400	365	330	300	270	
	6.50	121.57	400	400	400	400	400	400	400	400	400	400	365	330	300	
	7.00	133.64	400	400	400	400	400	400	400	400	400	400	400	365	330	
	7.25	139.67	400	400	400	400	400	400	400	400	400	400	400	380	345	
	7.50	145.71	400	400	400	400	400	400	400	400	400	400	400	400	360	
16 gage	4.50	73.29	400	400	400	400	400	390	345	305	270	245	220	195	180	
	5.00	85.36	400	400	400	400	400	400	400	355	320	285	255	230	210	
	5.50	97.43	400	400	400	400	400	400	400	400	365	325	295	265	240	
	6.00	109.50	400	400	400	400	400	400	400	400	400	365	330	300	270	
	6.50	121.57	400	400	400	400	400	400	400	400	400	400	365	330	300	
	7.00	133.64	400	400	400	400	400	400	400	400	400	400	400	365	330	
	7.25	139.67	400	400	400	400	400	400	400	400	400	400	400	400	380	345
	7.50	145.71	400	400	400	400	400	400	400	400	400	400	400	400	400	360
22 gage	4.50	35.55	380	320	270	230	200	170	150	130	115	100	90	80	70	
	5.00	41.78	400	375	320	270	235	205	180	155	135	120	105	95	85	
	5.50	48.19	400	400	370	315	270	235	205	180	160	140	125	110	100	
	6.00	54.74	400	400	400	360	310	270	235	205	180	160	140	125	110	
	6.50	61.40	400	400	400	400	350	305	265	235	205	180	160	140	125	
	7.00	68.15	400	400	400	400	390	340	295	260	230	200	180	160	140	
	7.25	71.55	400	400	400	400	400	355	310	275	240	215	190	170	150	
	7.50	74.96	400	400	400	400	400	370	325	285	250	225	200	175	155	
20 gage	4.50	42.94	400	390	330	285	245	215	190	165	145	130	115	100	90	
	5.00	50.48	400	400	390	335	290	255	220	195	175	155	135	120	110	
	5.50	58.25	400	400	400	390	335	295	255	225	200	180	160	140	125	
	6.00	66.21	400	400	400	400	385	335	295	260	230	205	180	160	145	
	6.50	74.31	400	400	400	400	400	375	330	290	260	230	205	185	165	
	7.00	82.52	400	400	400	400	400	400	370	325	290	255	230	205	185	
	7.25	86.66	400	400	400	400	400	400	390	340	305	270	240	215	195	
	7.50	90.82	400	400	400	400	400	400	400	360	320	285	250	225	205	
19 gage	4.50	49.32	400	400	385	330	290	250	220	195	170	155	135	120	110	
	5.00	58.03	400	400	400	390	340	295	260	230	205	180	160	145	130	
	5.50	67.03	400	400	400	400	395	345	300	265	235	210	190	170	150	
	6.00	76.25	400	400	400	400	400	395	345	305	270	240	215	195	175	
	6.50	85.63	400	400	400	400	400	400	390	345	305	270	245	220	195	
	7.00	95.15	400	400	400	400	400	400	400	385	340	305	270	245	220	
	7.25	99.96	400	400	400	400	400	400	400	400	360	320	285	255	230	
	7.50	104.78	400	400	400	400	400	400	400	400	375	335	300	270	245	
18 gage	4.50	54.96	400	400	400	375	325	285	250	220	195	175	155	140	125	
	5.00	64.68	400	400	400	400	385	335	295	260	230	205	185	165	150	
	5.50	74.74	400	400	400	400	400	390	340	300	270	240	215	195	175	
	6.00	85.06	400	400	400	400	400	400	390	345	305	275	245	220	200	
	6.50	95.58	400	400	400	400	400	400	400	390	345	310	275	250	225	
	7.00	106.25	400	400	400	400	400	400	400	400	385	345	310	280	250	
	7.25	111.64	400	400	400	400	400	400	400	400	400	365	325	295	265	
	7.50	117.05	400	400	400	400	400	400	400	400	400	380	340	310	280	
16 gage	4.50	54.96	400	400	400	375	325	285	250	220	195	175	155	140	125	
	5.00	64.68	400	400	400	400	385	335	295	260	230	205	185	165	150	
	5.50	74.74	400	400	400	400	400	390	340	300	270	240	215	195	175	
	6.00	85.06	400	400	400	400	400	400	390	345	305	275	245	220	200	
	6.50	95.58	400	400	400	400	400	400	400	390	345	310	275	250	225	
	7.00	106.25	400	400	400	400	400	400	400	400	385	345	310	280	250	
	7.25	111.64	400	400	400	400	400	400	400	400	400	365	325	295	265	
	7.50	117.05	400	400	400	400	400	400	400	400	400	380	340	310	280	

Studs at 1 foot o.c.

No Studs

3" LOK-FLOOR

3" x 12" deck $F_y = 40 \text{ ksi}$ $f'_c = 3 \text{ ksi}$ 145 pcf concrete

Studs are not required for composite slab action. Studs on the cross-section indicate that it is possible to install studs at the beams.

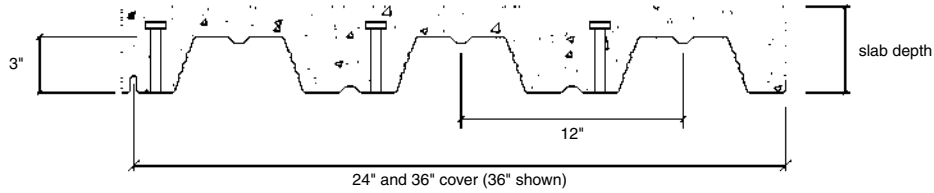

DECK PROPERTIES

Gage	t	w	A _s	I _p	S _p	S _n	φR _{be}	φR _{bi}	φV _n	studs
22	0.0295	1.7	0.500	0.765	0.416	0.441	720	1270	2200	0.49
20	0.0358	2.1	0.610	0.953	0.548	0.577	820	1450	3420	0.60
19	0.0418	2.4	0.710	1.112	0.680	0.692	1100	1930	4660	0.70
18	0.0474	2.8	0.810	1.261	0.793	0.790	1380	2430	5900	0.79
16	0.0598	3.5	1.020	1.593	0.998	0.998	2120	3710	7420	0.79

COMPOSITE PROPERTIES

	Slab Depth	φM _{nt} in.k	A _c in ²	Vol. ft ³ /ft ²	W psf	S _c in ³	I _{av} in ⁴	φM _{no} in.k	φV _{nt} lbs.	Max Unshored Span, ft.			A _{wvf} in ² /ft
										1 span	2 span	3 span	
22 gage	5.50	62.44	37.6	0.333	48	1.31	10.1	44.61	5700	7.84	9.46	9.86	0.023
	6.00	70.94	42.0	0.375	54	1.50	12.9	51.25	6110	7.47	8.68	9.04	0.027
	6.50	79.44	46.6	0.417	60	1.71	16.3	58.14	6540	6.95	8.02	8.35	0.032
	7.00	87.94	51.3	0.458	66	1.92	20.2	65.23	6980	6.52	7.45	7.76	0.036
	7.50	96.44	56.3	0.500	73	2.13	24.7	72.47	7440	6.14	6.96	7.25	0.041
	8.00	104.94	61.3	0.542	79	2.35	29.8	79.84	7910	5.81	6.53	6.80	0.045
	8.25	109.19	63.9	0.563	82	2.46	32.6	83.57	8150	5.65	6.33	6.59	0.047
20 gage	5.50	62.44	37.6	0.333	48	1.57	10.8	53.50	6920	9.20	10.76	11.21	0.023
	6.00	85.06	42.0	0.375	54	1.81	13.8	61.49	7330	8.76	9.87	10.28	0.027
	6.50	95.43	46.6	0.417	60	2.05	17.3	69.79	7760	8.29	9.12	9.50	0.032
	7.00	105.80	51.3	0.458	66	2.30	21.5	78.33	8200	7.78	8.48	8.83	0.036
	7.50	116.17	56.3	0.500	73	2.56	26.2	87.08	8660	7.33	7.92	8.25	0.041
	8.00	126.54	61.3	0.542	79	2.82	31.6	96.00	9130	6.93	7.43	7.74	0.045
	8.25	131.73	63.9	0.563	82	2.95	34.6	100.50	9370	6.74	7.21	7.51	0.047
19 gage	5.50	136.91	66.6	0.583	85	3.09	37.7	105.04	9620	6.57	7.00	7.29	0.050
	6.00	109.35	42.0	0.375	54	2.07	14.5	70.61	7820	9.90	12.08	12.48	0.027
	6.50	109.50	46.6	0.417	60	2.35	18.2	80.17	8680	9.47	11.61	11.99	0.032
	7.00	121.57	51.3	0.458	66	2.64	22.5	90.02	9440	9.22	11.18	11.55	0.036
	7.50	133.64	56.3	0.500	73	2.94	27.5	100.12	9900	8.98	10.51	10.95	0.041
	8.00	145.71	61.3	0.542	79	3.24	33.1	110.41	10370	8.76	9.86	10.27	0.045
	8.25	151.74	63.9	0.563	82	3.40	36.2	115.62	10610	8.66	9.57	9.97	0.047
18 gage	5.50	157.78	66.6	0.583	85	3.55	39.5	120.87	10860	8.56	9.29	9.68	0.050
	6.00	95.58	37.6	0.333	48	2.02	11.9	69.22	7000	11.34	13.49	13.94	0.023
	6.50	109.35	42.0	0.375	54	2.33	15.2	79.55	7820	10.78	12.92	13.35	0.027
	7.00	123.12	46.6	0.417	60	2.65	19.1	90.34	8680	10.32	12.42	12.83	0.032
	7.50	136.89	51.3	0.458	66	2.97	23.6	101.48	9560	10.04	11.97	12.37	0.036
	8.00	150.66	56.3	0.500	73	3.31	28.7	112.91	10480	9.77	11.56	11.95	0.041
	8.25	164.43	61.3	0.542	79	3.66	34.6	124.57	11420	9.53	11.19	11.57	0.045
16 gage	5.50	171.32	63.9	0.563	82	3.83	37.8	130.48	11850	9.42	11.02	11.39	0.047
	6.00	178.20	66.6	0.583	85	4.00	41.2	136.43	12100	9.31	10.86	11.22	0.050
	6.50	95.58	37.6	0.333	48	2.48	13.0	69.22	7000	12.86	15.12	15.46	0.023
	7.00	109.35	42.0	0.375	54	2.86	16.6	79.55	7820	12.23	14.49	14.97	0.027
	7.50	123.12	46.6	0.417	60	3.25	20.8	90.34	8680	11.70	13.93	14.40	0.032
	8.00	136.89	51.3	0.458	66	3.66	25.6	101.48	9560	11.37	13.43	13.88	0.036
	8.25	150.66	56.3	0.500	73	4.08	31.2	112.91	10480	11.08	12.98	13.41	0.041

Note:
50 ksi material is also available.
See website for load tables.

3" LOK-FLOOR - NW



3" LOK-FLOOR

3" x 12" deck $F_y = 40$ ksi $f'_c = 3$ ksi 145 pcf concrete

	Slab Depth	ϕM_n in.k	Span "L" feet, Uniform Live Unfactored Service Loads, psf												
			9.00	9.50	10.00	10.50	11.00	11.50	12.00	12.50	13.00	13.50	14.00	14.50	15.00
22 gage	5.50	62.44	285	250	225	200	180	160	145	130	115	105	95	85	80
	6.00	70.94	325	285	255	225	200	180	165	145	135	120	110	100	90
	6.50	79.44	360	320	285	255	225	205	185	165	150	135	120	110	100
	7.00	87.94	400	355	315	280	250	225	205	185	165	150	135	125	110
	7.50	96.44	400	390	345	310	275	250	225	200	180	165	150	135	125
	8.00	104.94	400	400	375	335	300	270	245	220	200	180	165	150	135
	8.25	109.19	400	400	395	350	315	280	255	230	205	185	170	155	140
	8.50	113.44	400	400	400	365	325	295	265	240	215	195	175	160	145
	5.50	74.69	345	305	275	245	220	200	180	160	145	135	120	110	100
20 gage	6.00	85.06	395	350	310	280	250	225	205	185	165	150	140	125	115
	6.50	95.43	400	395	350	315	280	255	230	210	190	170	155	140	130
	7.00	105.80	400	400	390	350	315	280	255	230	210	190	175	160	145
	7.50	116.17	400	400	400	385	345	310	280	255	230	210	190	175	160
	8.00	126.54	400	400	400	400	375	340	305	275	250	230	210	190	175
	8.25	131.73	400	400	400	400	390	350	320	290	260	240	215	200	180
	8.50	136.91	400	400	400	400	400	365	330	300	275	250	225	205	190
	5.50	85.36	400	355	320	285	255	230	210	190	170	155	145	130	120
	6.00	97.43	400	400	365	325	295	265	240	215	200	180	165	150	140
19 gage	6.50	109.50	400	400	400	365	330	300	270	245	225	205	185	170	155
	7.00	121.57	400	400	400	400	365	330	300	275	250	225	205	190	175
	7.50	133.64	400	400	400	400	400	365	330	300	275	250	230	210	190
	8.00	145.71	400	400	400	400	400	400	360	330	300	270	250	230	210
	8.25	151.74	400	400	400	400	400	400	375	340	310	285	260	240	220
	8.50	157.78	400	400	400	400	400	400	390	355	325	295	270	245	225
	5.50	95.58	400	400	360	325	290	265	240	215	195	180	165	150	140
	6.00	109.35	400	400	400	370	335	300	275	250	225	205	190	175	160
	6.50	123.12	400	400	400	400	375	340	310	280	255	235	215	195	180
18 gage	7.00	136.89	400	400	400	400	400	380	345	315	285	260	240	220	200
	7.50	150.66	400	400	400	400	400	400	380	345	315	290	265	240	225
	8.00	164.43	400	400	400	400	400	400	400	380	345	315	290	265	245
	8.25	171.32	400	400	400	400	400	400	400	395	360	330	300	275	255
	8.50	178.20	400	400	400	400	400	400	400	400	375	340	315	290	265
	5.50	95.58	400	400	360	325	290	265	240	215	195	180	165	150	140
	6.00	109.35	400	400	400	370	335	300	275	250	225	205	190	175	160
	6.50	123.12	400	400	400	400	375	340	310	280	255	235	215	195	180
	7.00	136.89	400	400	400	400	400	400	380	345	315	285	260	240	220
16 gage	7.50	150.66	400	400	400	400	400	400	380	345	315	290	265	240	225
	8.00	164.43	400	400	400	400	400	400	400	380	345	315	290	265	245
	8.25	171.32	400	400	400	400	400	400	400	395	360	330	300	275	255
	8.50	178.20	400	400	400	400	400	400	400	400	375	340	315	290	265
	5.50	44.61	190	170	150	130	115	105	90	80	70	65	55	50	45
	6.00	51.25	220	195	170	150	135	120	105	95	85	75	65	60	55
	6.50	58.14	250	220	195	175	155	135	120	110	95	85	75	70	60
	7.00	65.23	285	250	220	195	175	155	140	125	110	100	90	80	70
	7.50	72.47	315	280	245	220	195	175	155	140	125	110	100	90	80
22 gage	8.00	79.84	350	310	270	240	215	190	170	155	135	120	110	100	90
	8.25	83.57	365	325	285	255	225	200	180	160	145	130	115	105	90
	8.50	87.32	385	340	300	265	235	210	190	170	150	135	120	110	95
	5.50	53.50	235	210	185	165	145	130	115	105	95	85	75	70	60
	6.00	61.49	275	240	215	190	170	150	135	120	110	100	90	80	70
	6.50	69.79	310	275	245	215	195	175	155	140	125	115	100	90	80
	7.00	78.33	350	310	275	245	220	195	175	155	140	130	115	105	95
	7.50	87.08	390	345	305	275	245	220	195	175	160	145	130	115	105
	8.00	96.00	400	385	340	300	270	240	215	195	175	160	145	130	115
20 gage	8.25	100.50	400	400	355	315	285	255	230	205	185	165	150	135	125
	8.50	105.04	400	400	375	330	295	265	240	215	195	175	160	145	130
	5.50	61.44	280	245	220	195	175	155	140	125	115	100	95	85	75
	6.00	70.61	320	285	250	225	200	180	160	145	130	120	110	95	90
	6.50	80.17	365	325	285	255	230	205	185	165	150	135	125	110	100
	7.00	90.02	400	365	325	290	260	230	210	190	170	155	140	125	115
	7.50	100.12	400	400	360	320	290	260	235	210	190	175	155	140	130
	8.00	110.41	400	400	400	355	320	285	260	235	210	190	175	160	145
	8.25	115.62	400	400	400	375	335	300	270	245	220	200	185	165	150
19 gage	8.50	120.87	400	400	400	390	350	315	285	255	235	210	190	175	160
	5.50	69.22	320	280	250	225	200	180	160	145	130	120	110	100	90
	6.00	79.55	365	325	290	260	230	210	185	170	155	140	125	115	105
	6.50	90.34	400	370	330	295	265	235	215	195	175	160	145	130	120
	7.00	101.48	400	400	370	330	300	270	240	220	200	180	165	150	135
	7.50	112.91	400	400	400	370	330	300	270	245	220	200	185	165	155
	8.00	124.57	400	400	400	400	370	330	300	270	245	225	205	185	170
	8.25	130.48	400	400	400	400	385	350	315	285	260	235	215	195	180
	8.50	136.43	400	400	400	400	400	365	330	300	270	245	225	205	185
18 gage	5.50	69.22	320	280	250	225	200	180	160	145	130	120	110	100	90
	6.00	79.55	365	325	290	260	230	210	185	170	155	140	125	115	105
	6.50	90.34	400	370	330	295	265	235	215	195	175	160	145	130	120
	7.00	101.48	400	400	370	330	300	270	240	220	200	180	165	150	135
	7.50	112.91	400	400	400	370	330	300	270	245	220	200	185	165	155
	8.00	124.57	400	400	400	400	370	330	300	270	245	225	205	185	170
	8.25	130.48	400	400	400	400	385	350	315	285	260	235	215	195	180
	8.50	136.43	400	400	400	400	400	365	330	300	270	245	225	205	185
	5.50	69.22	320	280	250	225	200	180	160	145	130	120	110	100	90
16 gage	6.00	79.55	365	325	290	260	230	210	185	170	155	140	125	115	105
	6.50	90.34	400	370	330	295	265	235	215	195	175	160	145	130	120
	7.00	101.48	400	400	370	330	300	270	240	220	200	180	165	150	135
	7.50	112.91	400	400	400	370	330	300	270	245	220	200	185	165	155
	8.00	124.57	400	400	400	400	370	330	300	270	245	225	205	185	170
	8.25	130.48	400	400	400	400	385	350	315	285	260	235	215	195	180
	8.50	136.43	400	400	400	400	400	365	330	300	270	245	225	205	185
	5.50	69.22	320	280	250	225	200	180	160	145	130	120	110	100	90
	6.00	79.55	365	325	290	260	230	210	185	170	155	140	125	115	105
6.50	90.34	400	370	330	295	265	235	215	195	175	160	145	130	120	
7.00	101.48	400	400	370	330	300	270	240	220	200	180	165	150		

B-LOK

1.5" x 6" deck $F_y = 40 \text{ ksi}$ $f'_c = 3 \text{ ksi}$ 115 pcf concrete

Studs are not required for composite slab action. Studs on the cross-section indicate that it is possible to install studs at the beams.

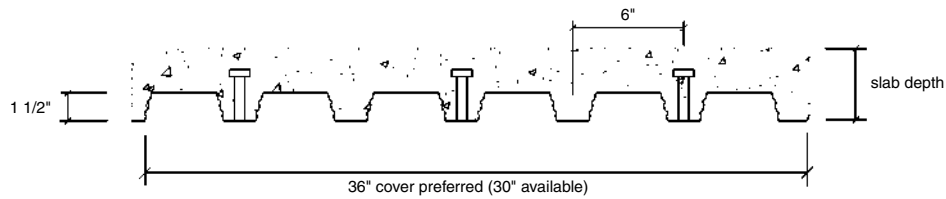

DECK PROPERTIES

Gage	t	w	A_s	I_p	S_p	S_n	ϕR_{be}	ϕR_{bi}	ϕV_n	studs
22	0.0295	1.6	0.470	0.158	0.189	0.191	1290	1690	2830	0.62
20	0.0358	1.9	0.570	0.205	0.233	0.241	1830	2440	3420	0.75
19	0.0418	2.3	0.670	0.251	0.276	0.283	2420	3270	3980	0.88
18	0.0474	2.6	0.760	0.294	0.317	0.322	3040	4140	4500	1.00
16	0.0598	3.3	0.960	0.380	0.406	0.408	4620	6390	5620	1.00

COMPOSITE PROPERTIES

	Slab Depth	ϕM_{nt} in.k	A_c in ²	Vol. ft ³ /ft ²	W psf	S_c in ³	I_{av} in ⁴	ϕM_{no} in.k	ϕV_{nt} lbs.	Max Unshored Span, ft.			A_{wvf} in ² /ft
										1 span	2 span	3 span	
22 gage	4.00	45.43	21.3	0.255	29	0.91	3.1	30.99	2980	5.73	7.63	7.72	0.023
	4.50	53.42	24.8	0.297	34	1.11	4.3	37.63	3460	5.46	7.28	7.37	0.027
	4.75	57.41	26.5	0.318	37	1.21	5.1	41.04	3700	5.33	7.13	7.22	0.029
	5.00	61.41	28.3	0.339	39	1.31	5.9	44.48	3960	5.22	6.98	7.07	0.032
	5.50	69.40	32.1	0.380	44	1.51	7.8	51.47	4480	5.01	6.72	6.80	0.036
	5.75	73.39	34.0	0.401	46	1.62	8.9	55.01	4750	4.92	6.60	6.68	0.038
20 gage	6.00	77.39	36.0	0.422	49	1.72	10.1	58.58	5030	4.83	6.49	6.57	0.041
	6.50	85.38	40.1	0.464	53	1.93	12.8	65.77	5600	4.67	6.28	6.36	0.045
	4.00	53.83	21.3	0.255	29	1.08	3.3	36.80	2980	6.57	8.77	8.88	0.023
	4.50	63.52	24.8	0.297	34	1.32	4.7	44.73	3460	6.24	8.36	8.46	0.027
	4.75	68.36	26.5	0.318	37	1.44	5.5	48.80	3700	6.09	8.17	8.27	0.029
	5.00	73.21	28.3	0.339	39	1.56	6.4	52.92	3960	5.96	8.00	8.09	0.032
19 gage	5.50	82.90	32.1	0.380	44	1.80	8.5	61.30	4480	5.71	7.69	7.78	0.036
	5.75	87.74	34.0	0.401	46	1.93	9.7	65.55	4750	5.60	7.55	7.64	0.038
	6.00	92.59	36.0	0.422	49	2.05	11.0	69.83	5030	5.50	7.41	7.50	0.041
	6.50	102.28	40.1	0.464	53	2.31	13.8	78.47	5600	5.31	7.17	7.25	0.045
	4.00	61.78	21.3	0.255	29	1.25	3.6	42.39	2980	7.32	9.57	9.90	0.023
	4.50	73.17	24.8	0.297	34	1.52	5.1	51.58	3460	6.94	9.13	9.42	0.027
18 gage	4.75	78.87	26.5	0.318	37	1.66	5.9	56.30	3700	6.77	8.93	9.21	0.029
	5.00	84.56	28.3	0.339	39	1.80	6.9	61.09	3960	6.62	8.74	9.01	0.032
	5.50	95.95	32.1	0.380	44	2.08	9.1	70.84	4480	6.34	8.40	8.65	0.036
	5.75	101.65	34.0	0.401	46	2.23	10.4	75.79	4750	6.22	8.24	8.48	0.038
	6.00	107.34	36.0	0.422	49	2.38	11.7	80.77	5030	6.10	8.10	8.33	0.041
	6.50	118.73	40.1	0.464	53	2.67	14.8	90.85	5600	5.88	7.82	8.05	0.045
16 gage	4.00	68.56	21.3	0.255	29	1.39	3.8	47.32	2980	7.98	10.19	10.53	0.023
	4.50	81.48	24.8	0.297	34	1.69	5.4	57.61	3460	7.56	9.72	10.05	0.027
	4.75	87.94	26.5	0.318	37	1.85	6.3	62.91	3700	7.37	9.51	9.83	0.029
	5.00	94.40	28.3	0.339	39	2.01	7.3	68.29	3960	7.20	9.31	9.62	0.032
	5.50	107.32	32.1	0.380	44	2.33	9.6	79.26	4480	6.89	8.95	9.25	0.036
	5.75	113.78	34.0	0.401	46	2.49	10.9	84.82	4750	6.76	8.78	9.08	0.038
16 gage	6.00	120.24	36.0	0.422	49	2.66	12.4	90.44	5030	6.63	8.62	8.91	0.041
	6.50	133.16	40.1	0.464	53	2.99	15.6	101.78	5600	6.39	8.33	8.61	0.045
	4.00	68.56	21.3	0.255	29	1.70	4.2	47.32	2980	9.27	11.42	11.80	0.023
	4.50	81.48	24.8	0.297	34	2.07	6.0	57.61	3460	8.77	10.90	11.27	0.027
	4.75	87.94	26.5	0.318	37	2.26	7.0	62.91	3700	8.55	10.66	11.02	0.029
	5.00	94.40	28.3	0.339	39	2.46	8.1	68.29	3960	8.35	10.44	10.79	0.032
16 gage	5.50	107.32	32.1	0.380	44	2.86	10.7	79.26	4480	7.98	10.04	10.38	0.036
	5.75	113.78	34.0	0.401	46	3.06	12.1	84.82	4750	7.82	9.85	10.19	0.038
	6.00	120.24	36.0	0.422	49	3.27	13.7	90.44	5030	7.66	9.68	10.01	0.041
	6.50	133.16	40.1	0.464	53	3.68	17.2	101.78	5600	7.38	9.36	9.67	0.045

Note:
50 ksi material is also available.
See website for load tables.

B-LOK - LW



B-LOK

1.5" x 6" deck $F_y = 40$ ksi $f'_c = 3$ ksi 115 pcf concrete

	Slab Depth	ϕM_n in.k	Span "L" feet, Uniform Live Unfactored Service Loads, psf																
			5.00	5.50	6.00	6.50	7.00	7.50	8.00	8.50	9.00	9.50	10.00	10.50	11.00				
22 gage	4.00	45.43	400	400	400	400	400	365	315	260	220	185	155	135	115	100			
	4.50	53.42	400	400	400	400	400	400	370	320	280	250	220	190	165	145			
	4.75	57.41	400	400	400	400	400	400	395	345	305	265	235	210	190	165			
	5.00	61.41	400	400	400	400	400	400	400	370	325	285	255	225	200	180			
	5.50	69.40	400	400	400	400	400	400	400	400	365	325	285	255	230	205			
	5.75	73.39	400	400	400	400	400	400	400	400	385	340	305	270	240	215			
	6.00	77.39	400	400	400	400	400	400	400	400	400	360	320	285	255	230			
20 gage	6.50	85.38	400	400	400	400	400	400	400	400	400	355	315	280	255				
	4.00	53.83	400	400	400	400	400	400	345	285	240	200	170	145	125	110			
	4.50	63.52	400	400	400	400	400	400	400	385	335	285	240	205	180	155			
	4.75	68.36	400	400	400	400	400	400	400	400	365	325	280	240	210	180			
	5.00	73.21	400	400	400	400	400	400	400	400	390	345	305	275	245	210			
	5.50	82.90	400	400	400	400	400	400	400	400	400	390	350	310	280	250			
	5.75	87.74	400	400	400	400	400	400	400	400	400	400	370	330	295	265			
19 gage	6.00	92.59	400	400	400	400	400	400	400	400	400	400	390	350	310	280			
	6.50	102.28	400	400	400	400	400	400	400	400	400	400	400	385	345	310			
	4.00	61.78	400	400	400	400	400	400	375	305	255	215	185	155	135	120			
	4.50	73.17	400	400	400	400	400	400	400	400	360	305	260	220	190	165			
	4.75	78.87	400	400	400	400	400	400	400	400	400	355	305	260	225	195			
	5.00	84.56	400	400	400	400	400	400	400	400	400	400	350	300	260	225			
	5.50	95.95	400	400	400	400	400	400	400	400	400	400	400	400	365	330	295		
18 gage	5.75	101.65	400	400	400	400	400	400	400	400	400	400	400	385	350	315			
	6.00	107.34	400	400	400	400	400	400	400	400	400	400	400	400	370	330			
	6.50	118.73	400	400	400	400	400	400	400	400	400	400	400	400	400	365			
	4.00	68.56	400	400	400	400	400	400	400	395	325	270	230	195	165	145	125		
	4.50	81.48	400	400	400	400	400	400	400	400	400	385	325	275	235	205	175		
	4.75	87.94	400	400	400	400	400	400	400	400	400	400	380	320	275	240	205		
	5.00	94.40	400	400	400	400	400	400	400	400	400	400	400	375	320	275	240		
16 gage	5.50	107.32	400	400	400	400	400	400	400	400	400	400	400	400	365	315			
	5.75	113.78	400	400	400	400	400	400	400	400	400	400	400	400	395	355			
	6.00	120.24	400	400	400	400	400	400	400	400	400	400	400	400	400	375			
	6.50	133.16	400	400	400	400	400	400	400	400	400	400	400	400	400	400			
	4.00	68.56	400	400	400	400	400	400	400	395	325	270	230	195	165	145	125		
	4.50	81.48	400	400	400	400	400	400	400	400	400	385	325	275	235	205	175		
	4.75	87.94	400	400	400	400	400	400	400	400	400	400	380	320	275	240	205		
22 gage	5.00	94.40	400	400	400	400	400	400	400	400	400	400	400	375	320	275	240		
	5.50	107.32	400	400	400	400	400	400	400	400	400	400	400	400	400	365	315		
	5.75	113.78	400	400	400	400	400	400	400	400	400	400	400	400	400	395	355		
	6.00	120.24	400	400	400	400	400	400	400	400	400	400	400	400	400	400	375		
	6.50	133.16	400	400	400	400	400	400	400	400	400	400	400	400	400	400	400		
	4.00	30.99	400	400	335	280	240	205	180	155	135	120	105	95	85				
	4.50	37.63	400	400	400	345	295	250	220	190	165	145	130	115	105				
20 gage	4.75	41.04	400	400	400	375	320	275	240	210	180	160	140	125	115				
	5.00	44.48	400	400	400	400	350	300	260	225	200	175	155	140	125				
	5.50	51.47	400	400	400	400	400	345	300	265	230	205	180	160	145				
	5.75	55.01	400	400	400	400	400	370	320	280	245	220	195	170	155				
	6.00	58.58	400	400	400	400	400	395	345	300	265	235	205	185	165				
	6.50	65.77	400	400	400	400	400	400	385	340	295	260	235	205	185				
	4.00	36.80	400	400	400	340	290	250	215	190	165	145	130	115	105				
19 gage	4.50	44.73	400	400	400	400	355	305	265	230	205	180	160	140	125				
	4.75	48.80	400	400	400	400	385	335	290	255	220	195	175	155	140				
	5.00	52.92	400	400	400	400	400	360	315	275	240	215	190	170	150				
	5.50	61.30	400	400	400	400	400	400	365	320	280	250	220	195	175				
	5.75	65.55	400	400	400	400	400	400	400	390	340	300	265	235	210	190			
	6.00	69.83	400	400	400	400	400	400	400	400	365	320	285	255	225	205			
	6.50	78.47	400	400	400	400	400	400	400	400	400	360	320	285	255	230			
18 gage	4.00	42.39	400	400	400	395	335	290	250	220	195	170	155	135	120				
	4.50	51.58	400	400	400	400	400	355	310	270	240	210	190	170	150				
	4.75	56.30	400	400	400	400	400	390	335	295	260	230	205	185	165				
	5.00	61.09	400	400	400	400	400	400	365	320	285	250	225	200	180				
	5.50	70.84	400	400	400	400	400	400	400	375	330	295	260	235	210				
	5.75	75.79	400	400	400	400	400	400	400	400	375	335	300	265	240				
	6.00	80.77	400	400	400	400	400	400	400	400	400	375	335	300	265	240			
16 gage	6.50	90.85	400	400	400	400	400	400	400	400	400	380	335	300	270				
	4.00	47.32	400	400	400	400	380	325	285	250	220	195	165	145	125				
	4.50	57.61	400	400	400	400	400	400	350	305	270	240	215	190	170				
	4.75	62.91	400	400	400	400	400	400	380	335	295	260	235	210	185				
	5.00	68.29	400	400	400	400	400	400	400	365	320	285	255	225	205				
	5.50	79.26	400	400	400	400	400	400	400	400	375	330	295	265	240				
	5.75	84.82	400	400	400	400	400	400	400	400	400	375	330	295	265	240			
16 gage	6.00	90.44	400	400	400	400	400	400	400	400	400	380	340	305	275				
	6.50	101.78	400	400	400	400	400	400	400	400	400	400	380	340	305	275			
	4.00	47.32	400	400	400	400	380	325	285	250	220	195	165	145	125				
	4.50	57.61	400	400	400	400	400	400	350	305	270	240	215	190	170				
	4.75	62.91	400	400	400	400	400	400	380	335	295	260	235	210	185				
	5.00	68.29	400	400	400	400	400	400	400	365	320	285	255	225	205				
	5.50	79.26	400	400	400	400	400	400	400	400	375	330	295	265	240				
16 gage	5.75	84.82	400	400	400	400	400	400	400	400	400	375	330	295	265	240			
	6.00	90.44	400	400	400	400	400	400	400	400	400	400	380	340	305	275			
	6.50	101.78	400	400	400	400	400	400	400	400	400	400	400	380	340	305	275		

Studs at 1 foot o.c.

No Studs

INVERTED B-LOK

Inverted 1.5" x 6" deck $F_y = 40 \text{ ksi}$ $f'_c = 3 \text{ ksi}$ 115 pcf concrete

Studs are not required for composite slab action. Studs on the cross-section indicate that it is possible to install studs at the beams.

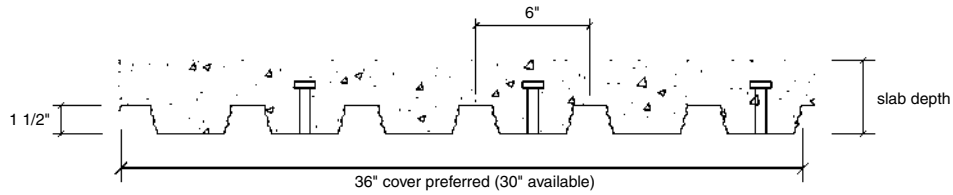

DECK PROPERTIES

Gage	t	w	A _s	I _p	S _p	S _n	φR _{be}	φR _{bi}	φV _n	studs
22	0.0295	1.6	0.470	0.184	0.191	0.189	1290	1690	2830	0.39
20	0.0358	1.9	0.570	0.225	0.241	0.233	1830	2440	3420	0.48
19	0.0418	2.3	0.670	0.264	0.283	0.276	2420	3270	3980	0.56
18	0.0474	2.6	0.760	0.300	0.322	0.317	3040	4140	4500	0.63
16	0.0598	3.3	0.960	0.380	0.408	0.406	4620	6390	5620	0.63

COMPOSITE PROPERTIES

	Slab Depth	φM _{nt} in.k	A _c in ²	Vol. ft ³ /ft ²	W psf	S _c in ³	I _{av} in ⁴	φM _{no} in.k	φV _{nt} lbs.	Max Unshored Span, ft.			A _{wvf} in ² /ft
										1 span	2 span	3 span	
22 gage	4.00	48.62	33.3	0.286	33	1.08	3.9	36.25	4660	5.56	7.42	7.51	0.023
	4.50	56.61	38.3	0.328	38	1.28	5.3	43.11	5340	5.31	7.11	7.19	0.027
	4.75	60.61	40.8	0.349	40	1.38	6.2	46.61	5680	5.20	6.96	7.05	0.029
	5.00	64.60	43.3	0.370	43	1.48	7.2	50.13	5860	5.09	6.83	6.91	0.032
	5.50	72.59	48.6	0.411	47	1.69	9.3	57.26	6220	4.91	6.59	6.67	0.036
	5.75	76.59	51.3	0.432	50	1.80	10.6	60.85	6410	4.82	6.48	6.56	0.038
20 gage	6.00	80.58	54.0	0.453	52	1.90	11.9	64.47	6600	4.74	6.38	6.45	0.041
	6.50	88.57	59.6	0.495	57	2.12	14.9	71.74	6990	4.59	6.18	6.26	0.045
	4.00	57.70	33.3	0.286	33	1.28	4.2	43.19	4660	6.46	8.40	8.68	0.023
	4.50	67.39	38.3	0.328	38	1.52	5.8	51.40	5340	6.16	8.03	8.30	0.027
	4.75	72.24	40.8	0.349	40	1.64	6.7	55.58	5690	6.02	7.87	8.13	0.029
	5.00	77.08	43.3	0.370	43	1.77	7.7	59.80	6050	5.90	7.71	7.97	0.032
19 gage	5.50	86.77	48.6	0.411	47	2.02	10.0	68.35	6790	5.67	7.42	7.67	0.036
	5.75	91.62	51.3	0.432	50	2.14	11.3	72.67	7000	5.57	7.29	7.53	0.038
	6.00	96.46	54.0	0.453	52	2.27	12.8	77.02	7190	5.47	7.16	7.41	0.041
	6.50	106.15	59.6	0.495	57	2.53	15.9	85.76	7580	5.29	6.93	7.16	0.045
	4.00	66.34	33.3	0.286	33	1.47	4.4	49.91	4660	7.14	9.12	9.43	0.023
	4.50	77.73	38.3	0.328	38	1.75	6.1	59.44	5340	6.80	8.73	9.02	0.027
18 gage	4.75	83.42	40.8	0.349	40	1.90	7.1	64.30	5690	6.65	8.55	8.83	0.029
	5.00	89.12	43.3	0.370	43	2.04	8.2	69.21	6050	6.51	8.38	8.66	0.032
	5.50	100.51	48.6	0.411	47	2.33	10.7	79.17	6790	6.25	8.07	8.34	0.036
	5.75	106.20	51.3	0.432	50	2.48	12.1	84.20	7160	6.13	7.92	8.19	0.038
	6.00	111.90	54.0	0.453	52	2.63	13.6	89.27	7540	6.02	7.79	8.05	0.041
	6.50	123.29	59.6	0.495	57	2.93	16.9	99.47	8140	5.82	7.54	7.79	0.045
16 gage	4.00	73.73	33.3	0.286	33	1.65	4.7	55.87	4660	7.73	9.76	10.09	0.023
	4.50	86.65	38.3	0.328	38	1.96	6.4	66.55	5340	7.36	9.34	9.65	0.027
	4.75	93.11	40.8	0.349	40	2.12	7.5	72.01	5690	7.19	9.15	9.45	0.029
	5.00	99.57	43.3	0.370	43	2.28	8.6	77.54	6050	7.03	8.97	9.27	0.032
	5.50	112.49	48.6	0.411	47	2.61	11.2	88.74	6790	6.75	8.64	8.93	0.036
	5.75	118.95	51.3	0.432	50	2.78	12.7	94.41	7160	6.63	8.48	8.77	0.038
16 gage	6.00	125.41	54.0	0.453	52	2.95	14.2	100.12	7540	6.51	8.34	8.62	0.041
	6.50	138.33	59.6	0.495	57	3.28	17.8	111.62	8320	6.29	8.07	8.34	0.045
	4.00	73.73	33.3	0.286	33	2.01	5.1	55.87	4660	8.91	10.99	11.37	0.023
	4.50	86.65	38.3	0.328	38	2.40	7.1	66.55	5340	8.47	10.53	10.88	0.027
	4.75	93.11	40.8	0.349	40	2.60	8.2	72.01	5690	8.27	10.31	10.66	0.029
	5.00	99.57	43.3	0.370	43	2.80	9.5	77.54	6050	8.09	10.11	10.45	0.032
16 gage	5.50	112.49	48.6	0.411	47	3.21	12.3	88.74	6790	7.76	9.74	10.07	0.036
	5.75	118.95	51.3	0.432	50	3.42	13.9	94.41	7160	7.61	9.57	9.89	0.038
	6.00	125.41	54.0	0.453	52	3.63	15.7	100.12	7540	7.47	9.41	9.73	0.041
	6.50	138.33	59.6	0.495	57	4.05	19.5	111.62	8320	7.21	9.11	9.42	0.045

Note:
50 ksi material is also available.
See website for load tables.

INVERTED B-LOK - LW

FLOOR DECK



INVERTED B-LOK

Inverted 1.5" x 6" deck $F_y = 40$ ksi $f'_c = 3$ ksi 115 pcf concrete

	Slab Depth	ϕM_n in.k	Span "L" feet, Uniform Live Unfactored Service Loads, psf													
			5.00	5.50	6.00	6.50	7.00	7.50	8.00	8.50	9.00	9.50	10.00	10.50	11.00	
22 gage	4.00	48.62	400	400	400	400	400	390	335	290	255	225	195	170	145	125
	4.50	56.61	400	400	400	400	400	390	340	295	260	230	205	185	165	155
	4.75	60.61	400	400	400	400	400	400	365	320	280	250	220	200	175	165
	5.00	64.60	400	400	400	400	400	400	390	340	300	265	235	210	190	180
	5.50	72.59	400	400	400	400	400	400	400	380	335	300	265	240	215	205
	5.75	76.59	400	400	400	400	400	400	400	400	355	315	280	250	225	215
	6.00	80.58	400	400	400	400	400	400	400	400	375	330	295	265	235	225
	6.50	88.57	400	400	400	400	400	400	400	400	400	365	325	290	260	250
20 gage	4.00	57.70	400	400	400	400	400	400	350	295	250	210	180	155	135	125
	4.50	67.39	400	400	400	400	400	400	400	360	315	280	250	215	190	180
	4.75	72.24	400	400	400	400	400	400	400	385	340	300	270	240	215	205
	5.00	77.08	400	400	400	400	400	400	400	400	365	325	290	260	230	220
	5.50	86.77	400	400	400	400	400	400	400	400	400	365	325	290	260	250
	5.75	91.62	400	400	400	400	400	400	400	400	400	385	345	310	275	265
	6.00	96.46	400	400	400	400	400	400	400	400	400	400	360	325	290	280
	6.50	106.15	400	400	400	400	400	400	400	400	400	400	400	360	325	290
19 gage	4.00	66.34	400	400	400	400	400	400	380	315	265	225	195	165	145	135
	4.50	77.73	400	400	400	400	400	400	400	400	365	310	270	230	200	190
	4.75	83.42	400	400	400	400	400	400	400	400	395	355	310	270	235	225
	5.00	89.12	400	400	400	400	400	400	400	400	400	380	340	305	270	260
	5.50	100.51	400	400	400	400	400	400	400	400	400	400	380	340	305	290
	5.75	106.20	400	400	400	400	400	400	400	400	400	400	400	380	340	310
	6.00	111.90	400	400	400	400	400	400	400	400	400	400	400	400	380	345
	6.50	123.29	400	400	400	400	400	400	400	400	400	400	400	400	400	380
18 gage	4.00	73.73	400	400	400	400	400	400	400	330	280	240	205	175	155	145
	4.50	86.65	400	400	400	400	400	400	400	400	385	330	280	245	210	200
	4.75	93.11	400	400	400	400	400	400	400	400	400	380	325	285	245	235
	5.00	99.57	400	400	400	400	400	400	400	400	400	400	375	325	285	275
	5.50	112.49	400	400	400	400	400	400	400	400	400	400	400	390	350	340
	5.75	118.95	400	400	400	400	400	400	400	400	400	400	400	400	370	360
	6.00	125.41	400	400	400	400	400	400	400	400	400	400	400	400	390	380
	6.50	138.33	400	400	400	400	400	400	400	400	400	400	400	400	400	400
16 gage	4.00	73.73	400	400	400	400	400	400	400	330	280	240	205	175	155	145
	4.50	86.65	400	400	400	400	400	400	400	400	385	330	280	245	210	200
	4.75	93.11	400	400	400	400	400	400	400	400	400	380	325	285	245	235
	5.00	99.57	400	400	400	400	400	400	400	400	400	400	375	325	285	275
	5.50	112.49	400	400	400	400	400	400	400	400	400	400	400	390	350	340
	5.75	118.95	400	400	400	400	400	400	400	400	400	400	400	400	370	360
	6.00	125.41	400	400	400	400	400	400	400	400	400	400	400	400	390	380
	6.50	138.33	400	400	400	400	400	400	400	400	400	400	400	400	400	400
22 gage	4.00	36.25	400	400	395	330	280	245	210	185	160	140	125	110	100	90
	4.50	43.11	400	400	400	395	335	290	250	220	190	170	150	135	120	110
	4.75	46.61	400	400	400	400	365	315	270	235	210	185	165	145	130	120
	5.00	50.13	400	400	400	400	395	340	295	255	225	200	175	155	140	130
	5.50	57.26	400	400	400	400	400	385	335	295	260	230	200	180	160	150
	5.75	60.85	400	400	400	400	400	400	360	310	275	240	215	190	170	160
	6.00	64.47	400	400	400	400	400	400	380	330	290	255	230	205	180	170
	6.50	71.74	400	400	400	400	400	400	400	370	325	285	255	225	205	195
20 gage	4.00	43.19	400	400	400	400	340	295	255	225	195	175	155	135	125	115
	4.50	51.40	400	400	400	400	400	350	305	265	235	210	185	165	145	135
	4.75	55.58	400	400	400	400	400	380	330	290	255	225	200	180	160	150
	5.00	59.80	400	400	400	400	400	400	355	310	275	245	215	195	175	165
	5.50	68.35	400	400	400	400	400	400	400	355	315	280	250	220	200	190
	5.75	72.67	400	400	400	400	400	400	400	380	335	295	265	235	210	200
	6.00	77.02	400	400	400	400	400	400	400	400	355	315	280	250	225	215
	6.50	85.76	400	400	400	400	400	400	400	400	395	350	315	280	250	240
19 gage	4.00	49.91	400	400	400	400	400	345	300	260	230	205	180	160	145	135
	4.50	59.44	400	400	400	400	400	400	355	315	275	245	220	195	175	165
	4.75	64.30	400	400	400	400	400	400	385	340	300	265	235	210	190	180
	5.00	69.21	400	400	400	400	400	400	400	365	320	285	255	230	205	195
	5.50	79.17	400	400	400	400	400	400	400	400	370	330	295	260	235	225
	5.75	84.20	400	400	400	400	400	400	400	400	395	350	310	280	250	240
	6.00	89.27	400	400	400	400	400	400	400	400	400	370	330	295	265	255
	6.50	99.47	400	400	400	400	400	400	400	400	400	400	370	330	300	290
18 gage	4.00	55.87	400	400	400	400	400	385	335	295	260	230	205	175	155	145
	4.50	66.55	400	400	400	400	400	400	400	355	310	275	245	220	200	190
	4.75	72.01	400	400	400	400	400	400	400	385	340	300	270	240	215	205
	5.00	77.54	400	400	400	400	400	400	400	400	365	325	290	260	235	225
	5.50	88.74	400	400	400	400	400	400	400	400	400	370	330	300	270	260
	5.75	94.41	400	400	400	400	400	400	400	400	400	395	355	320	285	275
	6.00	100.12	400	400	400	400	400	400	400	400	400	400	375	335	305	295
	6.50	111.62	400	400	400	400	400	400	400	400	400	400	400	375	340	330
16 gage	4.00	55.87	400	400	400	400	400	385	335	295	260	230	205	175	155	145
	4.50	66.55	400	400	400	400	400	400	400	355	310	275	245	220	200	190
	4.75	72.01	400	400	400	400	400	400	400	385	340	300	270	240	215	205
	5.00	77.54	400	400	400	400	400	400	400	400	365	325	290	260	235	225
	5.50	88.74	400	400	400	400	400	400	400	400	400	370	330	300	270	260
	5.75	94.41	400	400	400	400	400	400	400	400	400	395	355	320	285	275
	6.00	100.12	400	400	400	400	400	400	400	400	400	400	375	335	305	295
	6.50	111.62	400	400	400	400	400	400	400	400	400	400	400	375	340	330

Studs at 1 foot o.c.

No Studs

1.5" LOK-FLOOR

1.5" x 12" deck $F_y = 40 \text{ ksi}$ $f'_c = 3 \text{ ksi}$ 115 pcf concrete

Studs are not required for composite slab action. Studs on the cross-section indicate that it is possible to install studs at the beams.

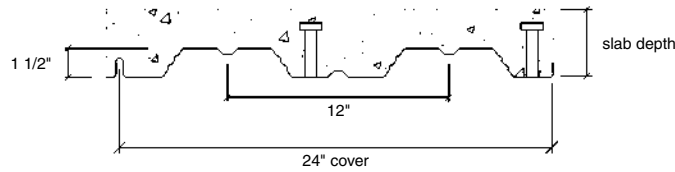

DECK PROPERTIES

Gage	t	w	A_s	I_p	S_p	S_n	ϕR_{be}	ϕR_{bi}	ϕV_n	studs
22	0.0295	1.5	0.430	0.177	0.187	0.196	550	910	1860	0.51
20	0.0358	1.8	0.520	0.225	0.249	0.258	780	1300	2250	0.62
19	0.0418	2.1	0.610	0.262	0.311	0.319	1040	1730	2620	0.73
18	0.0474	2.3	0.690	0.298	0.361	0.371	1310	2170	2970	0.82
16	0.0598	3.0	0.870	0.376	0.469	0.469	1990	3310	3730	0.82

COMPOSITE PROPERTIES

	Slab Depth	ϕM_{nt} in.k	A_c in ²	Vol. ft ³ /ft ²	W psf	S_c in ³	I_{av} in ⁴	ϕM_{no} in.k	ϕV_{nt} lbs.	Max Unshored Span, ft.			A_{wvf} in ² /ft
										1 span	2 span	3 span	
22 gage	4.00	43.41	30.7	0.271	31	0.93	3.4	31.63	4000	5.59	7.45	7.54	0.023
	4.50	50.72	36.0	0.313	36	1.11	4.7	37.78	4370	5.33	7.12	7.21	0.027
	4.75	54.37	38.8	0.333	38	1.20	5.5	40.92	4570	5.21	6.98	7.06	0.029
	5.00	58.03	41.7	0.354	41	1.29	6.3	44.09	4770	5.11	6.84	6.92	0.032
	5.50	65.34	47.0	0.396	46	1.48	8.3	50.53	5140	4.91	6.59	6.67	0.036
	5.75	68.99	49.4	0.417	48	1.58	9.4	53.79	5310	4.82	6.48	6.56	0.038
20 gage	6.00	72.65	51.8	0.438	50	1.68	10.7	57.07	5470	4.74	6.37	6.45	0.041
	6.50	79.96	56.5	0.479	55	1.87	13.4	63.68	5810	4.58	6.17	6.25	0.045
	4.00	51.45	30.7	0.271	31	1.10	3.6	37.56	4280	6.73	8.95	9.11	0.023
	4.50	60.29	36.0	0.313	36	1.31	5.1	44.88	4760	6.40	8.54	8.69	0.027
	4.75	64.71	38.8	0.333	38	1.43	5.9	48.63	4960	6.25	8.36	8.50	0.029
	5.00	69.13	41.7	0.354	41	1.54	6.8	52.43	5160	6.12	8.18	8.33	0.032
19 gage	5.50	77.97	47.0	0.396	46	1.76	8.9	60.14	5530	5.87	7.86	8.01	0.036
	5.75	82.39	49.4	0.417	48	1.88	10.1	64.04	5700	5.76	7.72	7.87	0.038
	6.00	86.81	51.8	0.438	50	2.00	11.4	67.97	5860	5.66	7.58	7.73	0.041
	6.50	95.65	56.5	0.479	55	2.23	14.4	75.89	6200	5.46	7.32	7.48	0.045
	4.00	59.14	30.7	0.271	31	1.26	3.9	43.22	4280	7.74	9.94	10.27	0.023
	4.50	69.51	36.0	0.313	36	1.51	5.4	51.72	5030	7.35	9.49	9.80	0.027
18 gage	4.75	74.69	38.8	0.333	38	1.64	6.3	56.07	5330	7.18	9.28	9.59	0.029
	5.00	79.88	41.7	0.354	41	1.77	7.3	60.48	5530	7.01	9.09	9.39	0.032
	5.50	90.25	47.0	0.396	46	2.04	9.5	69.45	5900	6.73	8.74	9.03	0.036
	5.75	95.43	49.4	0.417	48	2.17	10.8	73.99	6070	6.59	8.58	8.86	0.038
	6.00	100.62	51.8	0.438	50	2.31	12.2	78.56	6230	6.47	8.42	8.71	0.041
	6.50	110.99	56.5	0.479	55	2.58	15.3	87.79	6570	6.25	8.14	8.41	0.045
16 gage	4.00	65.67	30.7	0.271	31	1.41	4.1	48.11	4280	8.48	10.71	11.06	0.023
	4.50	77.40	36.0	0.313	36	1.69	5.7	57.63	5030	8.05	10.22	10.56	0.027
	4.75	83.26	38.8	0.333	38	1.83	6.6	62.51	5420	7.85	10.00	10.34	0.029
	5.00	89.13	41.7	0.354	41	1.98	7.7	67.46	5820	7.67	9.80	10.12	0.032
	5.50	100.86	47.0	0.396	46	2.27	10.0	77.53	6250	7.35	9.42	9.73	0.036
	5.75	106.72	49.4	0.417	48	2.42	11.4	82.64	6420	7.21	9.25	9.56	0.038
16 gage	6.00	112.59	51.8	0.438	50	2.58	12.8	87.78	6580	7.07	9.08	9.39	0.041
	6.50	124.32	56.5	0.479	55	2.88	16.0	98.17	6920	6.82	8.78	9.07	0.045
	4.00	65.67	30.7	0.271	31	1.72	4.5	48.11	4280	9.88	12.00	11.96	0.023
	4.50	77.40	36.0	0.313	36	2.06	6.3	57.63	5030	9.40	11.47	11.57	0.027
	4.75	83.26	38.8	0.333	38	2.24	7.3	62.51	5420	9.17	11.22	11.40	0.029
	5.00	89.13	41.7	0.354	41	2.42	8.4	67.46	5820	8.95	10.99	11.24	0.032
16 gage	5.50	100.86	47.0	0.396	46	2.79	11.0	77.53	6560	8.57	10.58	10.85	0.036
	5.75	106.72	49.4	0.417	48	2.98	12.5	82.64	6900	8.40	10.38	10.68	0.038
	6.00	112.59	51.8	0.438	50	3.17	14.1	87.78	7230	8.23	10.20	10.52	0.041
	6.50	124.32	56.5	0.479	55	3.55	17.6	98.17	7680	7.93	9.86	10.19	0.045

Note:
50 ksi material is also available.
See website for load tables.

1.5" LOK-FLOOR - LW

FLOOR DECK



1.5" LOK-FLOOR

1.5" x 12" deck $F_y = 40$ ksi $f'_c = 3$ ksi 115 pcf concrete

	Slab Depth	ϕM_n in.k	Span "L" feet, Uniform Live Unfactored Service Loads, psf													
			5.00	5.50	6.00	6.50	7.00	7.50	8.00	8.50	9.00	9.50	10.00	10.50	11.00	
22 gage	4.00	43.41	400	400	400	400	400	345	295	260	225	200	170	145	125	110
	4.50	50.72	400	400	400	400	400	400	350	300	265	235	205	185	165	145
	4.75	54.37	400	400	400	400	400	400	375	325	285	250	220	195	175	155
	5.00	58.03	400	400	400	400	400	400	400	345	305	265	235	210	190	170
	5.50	65.34	400	400	400	400	400	400	400	390	340	300	265	235	210	190
	5.75	68.99	400	400	400	400	400	400	400	400	360	320	280	250	225	200
	6.00	72.65	400	400	400	400	400	400	400	400	380	335	295	265	235	210
20 gage	4.00	51.45	400	400	400	400	400	400	355	310	260	220	185	160	140	120
	4.50	60.29	400	400	400	400	400	400	400	365	320	280	250	220	190	165
	4.75	64.71	400	400	400	400	400	400	400	390	345	305	270	240	215	195
	5.00	69.13	400	400	400	400	400	400	400	400	365	325	285	255	230	205
	5.50	77.97	400	400	400	400	400	400	400	400	400	365	325	290	260	235
	5.75	82.39	400	400	400	400	400	400	400	400	400	385	345	305	275	245
	6.00	86.81	400	400	400	400	400	400	400	400	400	400	360	325	290	260
19 gage	4.00	59.14	400	400	400	400	400	400	400	335	280	235	200	170	145	130
	4.50	69.51	400	400	400	400	400	400	400	400	370	325	275	235	205	180
	4.75	74.69	400	400	400	400	400	400	400	400	400	355	315	275	240	210
	5.00	79.88	400	400	400	400	400	400	400	400	400	380	335	300	270	240
	5.50	90.25	400	400	400	400	400	400	400	400	400	400	380	340	305	275
	5.75	95.43	400	400	400	400	400	400	400	400	400	400	400	360	325	290
	6.00	100.62	400	400	400	400	400	400	400	400	400	400	400	380	340	305
18 gage	4.00	110.99	400	400	400	400	400	400	400	400	400	400	400	400	375	340
	4.50	124.32	400	400	400	400	400	400	400	400	400	400	400	400	385	350
	4.75	131.40	400	400	400	400	400	400	400	400	400	400	400	400	400	385
	5.00	138.48	400	400	400	400	400	400	400	400	400	400	400	400	400	385
	5.50	150.86	400	400	400	400	400	400	400	400	400	400	400	400	400	385
	5.75	157.94	400	400	400	400	400	400	400	400	400	400	400	400	400	385
	6.00	165.02	400	400	400	400	400	400	400	400	400	400	400	400	400	385
16 gage	4.00	65.67	400	400	400	400	400	400	400	350	295	245	210	180	155	135
	4.50	77.40	400	400	400	400	400	400	400	400	345	290	250	215	190	170
	4.75	83.26	400	400	400	400	400	400	400	400	400	340	290	250	220	200
	5.00	89.13	400	400	400	400	400	400	400	400	400	400	380	335	290	255
	5.50	100.86	400	400	400	400	400	400	400	400	400	400	400	385	345	310
	5.75	106.72	400	400	400	400	400	400	400	400	400	400	400	400	365	330
	6.00	112.59	400	400	400	400	400	400	400	400	400	400	400	400	385	350
22 gage	4.00	124.32	400	400	400	400	400	400	400	400	400	400	400	400	400	385
	4.50	131.40	400	400	400	400	400	400	400	400	400	400	400	400	400	385
	4.75	138.48	400	400	400	400	400	400	400	400	400	400	400	400	400	385
	5.00	145.56	400	400	400	400	400	400	400	400	400	400	400	400	400	385
	5.50	157.94	400	400	400	400	400	400	400	400	400	400	400	400	400	385
	5.75	164.02	400	400	400	400	400	400	400	400	400	400	400	400	400	385
	6.00	170.10	400	400	400	400	400	400	400	400	400	400	400	400	400	385
20 gage	4.00	31.63	400	400	340	285	245	210	180	160	140	120	105	95	85	
	4.50	37.78	400	400	400	345	295	250	220	190	165	145	130	115	100	
	4.75	40.92	400	400	400	375	320	275	235	205	180	160	140	125	110	
	5.00	44.09	400	400	400	400	345	295	255	225	195	170	150	135	120	
	5.50	50.53	400	400	400	400	395	340	295	255	225	200	175	155	140	
	5.75	53.79	400	400	400	400	400	360	315	275	240	210	185	165	150	
	6.00	57.07	400	400	400	400	400	385	335	290	255	225	200	175	160	
19 gage	4.00	63.68	400	400	400	400	400	400	370	325	285	250	225	200	175	
	4.50	75.56	400	400	400	400	400	400	400	355	310	270	240	210	185	
	4.75	78.84	400	400	400	400	400	400	400	355	310	270	240	210	185	
	5.00	82.12	400	400	400	400	400	400	400	355	310	270	240	210	185	
	5.50	90.25	400	400	400	400	400	400	400	355	310	270	240	210	185	
	5.75	93.53	400	400	400	400	400	400	400	355	310	270	240	210	185	
	6.00	96.81	400	400	400	400	400	400	400	355	310	270	240	210	185	
18 gage	4.00	100.62	400	400	400	400	400	400	400	355	310	270	240	210	185	
	4.50	112.59	400	400	400	400	400	400	400	355	310	270	240	210	185	
	4.75	115.87	400	400	400	400	400	400	400	355	310	270	240	210	185	
	5.00	119.15	400	400	400	400	400	400	400	355	310	270	240	210	185	
	5.50	127.28	400	400	400	400	400	400	400	355	310	270	240	210	185	
	5.75	130.56	400	400	400	400	400	400	400	355	310	270	240	210	185	
	6.00	133.84	400	400	400	400	400	400	400	355	310	270	240	210	185	
16 gage	4.00	137.65	400	400	400	400	400	400	400	355	310	270	240	210	185	
	4.50	149.53	400	400	400	400	400	400	400	355	310	270	240	210	185	
	4.75	152.81	400	400	400	400	400	400	400	355	310	270	240	210	185	
	5.00	156.09	400	400	400	400	400	400	400	355	310	270	240	210	185	
	5.50	164.22	400	400	400	400	400	400	400	355	310	270	240	210	185	
	5.75	167.50	400	400	400	400	400	400	400	355	310	270	240	210	185	
	6.00	170.78	400	400	400	400	400	400	400	355	310	270	240	210	185	

Studs at 1 foot o.c.

No Studs

2" LOK-FLOOR

2" x 12" deck $F_y = 40 \text{ ksi}$ $f'_c = 3 \text{ ksi}$ 115 pcf concrete

Studs are not required for composite slab action. Studs on the cross-section indicate that it is possible to install studs at the beams.

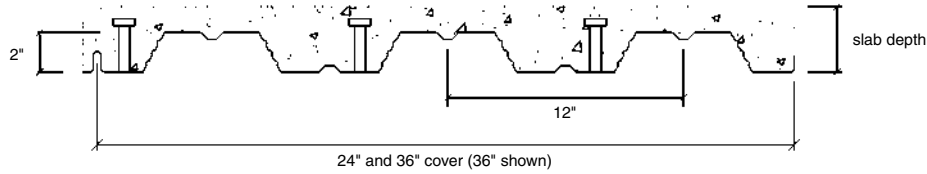

DECK PROPERTIES

Gage	t	w	A_s	I_p	S_p	S_n	ϕR_{be}	ϕR_{bi}	ϕV_n	studs
22	0.0295	1.5	0.440	0.312	0.251	0.262	700	1190	2160	0.51
20	0.0358	1.8	0.540	0.390	0.332	0.345	800	1360	2930	0.62
19	0.0418	2.1	0.630	0.455	0.413	0.424	1060	1800	3410	0.73
18	0.0474	2.4	0.710	0.517	0.480	0.483	1340	2270	3860	0.82
16	0.0598	3.1	0.900	0.653	0.611	0.611	2040	3460	4860	0.82

COMPOSITE PROPERTIES

	Slab Depth	ϕM_{nt} in.k	A_c in ²	Vol. ft ³ /ft ²	W psf	S_c in ³	I_{av} in ⁴	ϕM_{no} in.k	ϕV_{nt} lbs.	Max Unshored Span, ft.			A_{wvf} in ² /ft
										1 span	2 span	3 span	
22 gage	4.50	48.06	32.6	0.292	34	0.99	4.4	34.01	4440	6.60	8.81	8.96	0.023
	5.00	55.54	37.5	0.333	38	1.17	6.0	40.07	4780	6.29	8.43	8.56	0.027
	5.25	59.28	40.0	0.354	41	1.26	6.9	43.18	4960	6.16	8.25	8.39	0.029
	5.50	63.02	42.6	0.375	43	1.36	7.8	46.33	5140	6.03	8.08	8.22	0.032
	6.00	70.50	48.0	0.417	48	1.55	10.1	52.76	5510	5.80	7.78	7.92	0.036
	6.25	74.24	50.8	0.438	50	1.64	11.3	56.01	5710	5.69	7.64	7.78	0.038
	6.50	77.98	53.6	0.458	53	1.74	12.7	59.30	5900	5.59	7.51	7.65	0.041
20 gage	7.00	85.46	59.5	0.500	58	1.94	15.7	65.93	6320	5.41	7.26	7.41	0.045
	4.50	57.78	32.6	0.292	34	1.19	4.8	40.93	4560	7.86	10.12	10.46	0.023
	5.00	66.96	37.5	0.333	38	1.41	6.5	48.24	5240	7.48	9.68	10.01	0.027
	5.25	71.55	40.0	0.354	41	1.52	7.4	52.00	5590	7.31	9.48	9.80	0.029
	5.50	76.14	42.6	0.375	43	1.63	8.5	55.81	5910	7.15	9.29	9.60	0.032
	6.00	85.32	48.0	0.417	48	1.86	10.9	63.60	6280	6.87	8.95	9.25	0.036
	6.25	89.91	50.8	0.438	50	1.98	12.2	67.55	6480	6.74	8.79	9.08	0.038
19 gage	6.50	94.50	53.6	0.458	53	2.10	13.6	71.53	6670	6.62	8.64	8.92	0.041
	7.00	103.68	59.5	0.500	58	2.34	16.9	79.60	7090	6.39	8.35	8.63	0.045
	4.50	66.15	32.6	0.292	34	1.37	5.1	46.87	4560	8.98	11.21	11.58	0.023
	5.00	76.86	37.5	0.333	38	1.62	6.9	55.29	5240	8.53	10.72	11.08	0.027
	5.25	82.21	40.0	0.354	41	1.74	7.9	59.63	5590	8.33	10.50	10.85	0.029
	5.50	87.57	42.6	0.375	43	1.87	9.0	64.03	5950	8.15	10.29	10.64	0.032
	6.00	98.28	48.0	0.417	48	2.14	11.5	73.03	6700	7.81	9.91	10.24	0.036
18 gage	6.25	103.63	50.8	0.438	50	2.27	12.9	77.60	6960	7.66	9.74	10.06	0.038
	6.50	108.99	53.6	0.458	53	2.41	14.5	82.21	7150	7.52	9.57	9.89	0.041
	7.00	119.70	59.5	0.500	58	2.69	17.9	91.55	7570	7.26	9.26	9.57	0.045
	4.50	73.29	32.6	0.292	34	1.52	5.4	52.11	4560	9.82	11.95	12.35	0.023
	5.00	85.36	37.5	0.333	38	1.79	7.2	61.48	5240	9.32	11.43	11.82	0.027
	5.25	91.39	40.0	0.354	41	1.94	8.3	66.32	5590	9.10	11.20	11.57	0.029
	5.50	97.43	42.6	0.375	43	2.08	9.4	71.24	5950	8.90	10.98	11.35	0.032
16 gage	6.00	109.50	48.0	0.417	48	2.38	12.1	81.29	6700	8.53	10.57	10.93	0.036
	6.25	115.53	50.8	0.438	50	2.53	13.6	86.41	7090	8.36	10.39	10.73	0.038
	6.50	121.57	53.6	0.458	53	2.68	15.2	91.57	7490	8.21	10.21	10.55	0.041
	7.00	133.64	59.5	0.500	58	2.99	18.7	102.02	8020	7.92	9.88	10.21	0.045
	4.50	73.29	32.6	0.292	34	1.86	5.9	52.11	4560	11.29	13.39	13.49	0.023
	5.00	85.36	37.5	0.333	38	2.20	8.0	61.48	5240	10.71	12.82	13.08	0.027
	5.25	91.39	40.0	0.354	41	2.38	9.1	66.32	5590	10.46	12.56	12.90	0.029
16 gage	5.50	97.43	42.6	0.375	43	2.56	10.4	71.24	5950	10.22	12.32	12.73	0.032
	6.00	109.50	48.0	0.417	48	2.93	13.3	81.29	6700	9.79	11.87	12.27	0.036
	6.25	115.53	50.8	0.438	50	3.12	15.0	86.41	7090	9.59	11.66	12.05	0.038
	6.50	121.57	53.6	0.458	53	3.31	16.7	91.57	7490	9.41	11.47	11.85	0.041
	7.00	133.64	59.5	0.500	58	3.70	20.6	102.02	8310	9.07	11.10	11.47	0.045

Note:
50 ksi material is also available.
See website for load tables.

2" LOK-FLOOR - LW



2" LOK-FLOOR

2" x 12" deck $F_y = 40$ ksi $f'_c = 3$ ksi 115 pcf concrete

	Slab Depth	ϕM_n in.k	Span "L" feet, Uniform Live Unfactored Service Loads, psf													
			6.00	6.50	7.00	7.50	8.00	8.50	9.00	9.50	10.00	10.50	11.00	11.50	12.00	
22 gage	4.50	48.06	400	400	380	330	285	250	220	195	175	155	140	125	110	
	5.00	55.54	400	400	400	380	330	290	255	225	200	180	160	145	130	
	5.25	59.28	400	400	400	400	355	310	275	240	215	190	170	155	140	
	5.50	63.02	400	400	400	400	400	375	330	290	255	230	205	185	165	150
	6.00	70.50	400	400	400	400	400	400	370	325	290	255	230	205	185	165
	6.25	74.24	400	400	400	400	400	400	390	345	305	270	240	215	195	175
	6.50	77.98	400	400	400	400	400	400	400	360	320	285	255	230	205	185
	7.00	85.46	400	400	400	400	400	400	400	395	350	310	280	250	225	205
20 gage	4.50	57.78	400	400	400	400	350	305	270	240	210	180	160	140	120	
	5.00	66.96	400	400	400	400	400	355	315	280	250	225	200	180	165	
	5.25	71.55	400	400	400	400	400	380	335	300	265	240	215	195	175	
	5.50	76.14	400	400	400	400	400	400	360	320	285	255	230	205	185	
	6.00	85.32	400	400	400	400	400	400	400	355	320	285	255	230	210	
	6.25	89.91	400	400	400	400	400	400	400	375	335	300	270	245	220	
	6.50	94.50	400	400	400	400	400	400	400	395	355	315	285	255	235	
	7.00	103.68	400	400	400	400	400	400	400	400	385	345	315	280	255	
19 gage	4.50	66.15	400	400	400	400	400	355	310	260	225	195	170	150	130	
	5.00	76.86	400	400	400	400	400	400	365	325	290	260	225	200	175	
	5.25	82.21	400	400	400	400	400	400	390	345	310	280	250	225	200	
	5.50	87.57	400	400	400	400	400	400	400	370	330	295	270	240	220	
	6.00	98.28	400	400	400	400	400	400	400	400	370	335	300	270	245	
	6.25	103.64	400	400	400	400	400	400	400	400	390	350	320	285	260	
	6.50	108.99	400	400	400	400	400	400	400	400	400	370	335	300	275	
	7.00	119.70	400	400	400	400	400	400	400	400	400	400	365	330	300	
18 gage	4.50	73.29	400	400	400	400	400	385	325	275	235	205	180	155	135	
	5.00	85.36	400	400	400	400	400	400	400	365	320	275	240	210	185	
	5.25	91.39	400	400	400	400	400	400	400	390	350	315	275	240	210	
	5.50	97.43	400	400	400	400	400	400	400	400	370	335	300	275	240	
	6.00	109.50	400	400	400	400	400	400	400	400	400	375	340	305	280	
	6.25	115.53	400	400	400	400	400	400	400	400	400	395	360	325	295	
	6.50	121.57	400	400	400	400	400	400	400	400	400	400	375	340	310	
	7.00	133.64	400	400	400	400	400	400	400	400	400	400	400	375	340	
16 gage	4.50	73.29	400	400	400	400	400	385	325	275	235	205	180	155	135	
	5.00	85.36	400	400	400	400	400	400	400	365	320	275	240	210	185	
	5.25	91.39	400	400	400	400	400	400	400	390	350	315	275	240	210	
	5.50	97.43	400	400	400	400	400	400	400	400	370	335	300	275	240	
	6.00	109.50	400	400	400	400	400	400	400	400	400	375	340	305	280	
	6.25	115.53	400	400	400	400	400	400	400	400	400	395	360	325	295	
	6.50	121.57	400	400	400	400	400	400	400	400	400	400	375	340	310	
	7.00	133.64	400	400	400	400	400	400	400	400	400	400	400	375	340	
22 gage	4.50	34.01	365	310	265	225	195	170	150	130	115	100	90	80	70	
	5.00	40.07	400	365	310	265	230	200	175	155	135	120	110	95	85	
	5.25	43.18	400	395	335	290	250	215	190	170	150	130	115	105	95	
	5.50	46.33	400	400	360	310	270	235	205	180	160	140	125	115	100	
	6.00	52.76	400	400	400	350	305	265	235	205	185	160	145	130	115	
	6.25	56.01	400	400	400	375	325	285	250	220	195	175	155	140	125	
	6.50	59.30	400	400	400	400	345	300	265	235	205	185	165	145	130	
	7.00	65.93	400	400	400	400	385	335	295	260	230	205	185	165	145	
20 gage	4.50	40.93	400	375	320	275	240	210	185	160	145	130	115	100	90	
	5.00	48.24	400	400	380	325	285	250	220	195	170	150	135	120	110	
	5.25	52.00	400	400	400	355	305	270	235	210	185	165	145	130	120	
	5.50	55.81	400	400	400	380	330	290	255	225	200	175	160	140	130	
	6.00	63.60	400	400	400	400	375	330	290	255	230	205	180	165	145	
	6.25	67.55	400	400	400	400	400	350	310	275	240	215	195	175	155	
	6.50	71.53	400	400	400	400	400	370	325	290	255	230	205	185	165	
	7.00	79.60	400	400	400	400	400	400	365	325	285	255	230	205	185	
19 gage	4.50	46.87	400	400	370	320	280	245	215	190	170	150	135	120	110	
	5.00	55.29	400	400	400	380	330	290	255	225	200	180	160	145	130	
	5.25	59.63	400	400	400	400	355	310	275	245	215	195	175	155	140	
	5.50	64.03	400	400	400	400	385	335	295	260	235	210	185	170	150	
	6.00	73.03	400	400	400	400	400	385	340	300	265	240	215	195	175	
	6.25	77.60	400	400	400	400	400	400	360	320	285	255	230	205	185	
	6.50	82.21	400	400	400	400	400	400	380	340	300	270	240	220	195	
	7.00	91.55	400	400	400	400	400	400	400	380	335	300	270	245	220	
18 gage	4.50	52.11	400	400	400	360	310	275	240	215	190	170	150	135	125	
	5.00	61.48	400	400	400	400	370	325	285	255	225	200	180	165	145	
	5.25	66.32	400	400	400	400	400	350	310	275	245	220	195	175	160	
	5.50	71.24	400	400	400	400	400	375	330	295	265	235	210	190	170	
	6.00	81.29	400	400	400	400	400	400	380	340	300	270	240	220	195	
	6.25	86.41	400	400	400	400	400	400	400	360	320	285	260	235	210	
	6.50	91.57	400	400	400	400	400	400	400	380	340	305	275	245	225	
	7.00	102.02	400	400	400	400	400	400	400	400	380	340	305	275	250	
16 gage	4.50	52.11	400	400	400	360	310	275	240	215	190	170	150	135	125	
	5.00	61.48	400	400	400	400	370	325	285	255	225	200	180	165	145	
	5.25	66.32	400	400	400	400	400	350	310	275	245	220	195	175	160	
	5.50	71.24	400	400	400	400	400	375	330	295	265	235	210	190	170	
	6.00	81.29	400	400	400	400	400	400	380	340	300	270	240	220	195	
	6.25	86.41	400	400	400	400	400	400	400	360	320	285	260	235	210	
6.50	91.57	400	400	400	400	400	400	400	380	340	305	275	245	225		
7.00	102.02	400	400	400	400	400	400	400	400	380	340	305	275	250		

Studs at 1 foot o.c.

No Studs

3" LOK-FLOOR

3" x 12" deck $F_y = 40 \text{ ksi}$ $f'_c = 3 \text{ ksi}$ 115 pcf concrete

Studs are not required for composite slab action. Studs on the cross-section indicate that it is possible to install studs at the beams.

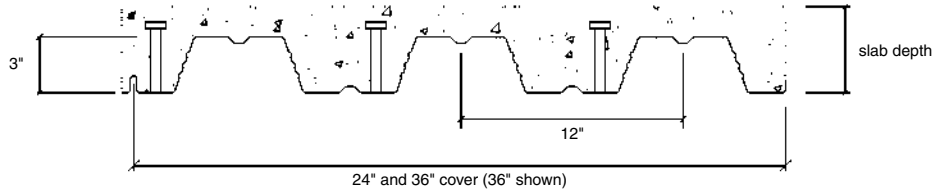

DECK PROPERTIES

Gage	t	w	A _s	I _p	S _p	S _n	φR _{be}	φR _{bi}	φV _n	studs
22	0.0295	1.7	0.500	0.765	0.416	0.441	720	1270	2200	0.59
20	0.0358	2.1	0.610	0.953	0.548	0.577	820	1450	3420	0.71
19	0.0418	2.4	0.710	1.112	0.680	0.692	1100	1930	4660	0.83
18	0.0474	2.8	0.810	1.261	0.793	0.790	1380	2430	5900	0.94
16	0.0598	3.5	1.020	1.593	0.998	0.998	2120	3710	7420	0.94

COMPOSITE PROPERTIES

	Slab Depth	φM _{nt} in.k	A _c in ²	Vol. ft ³ /ft ²	W psf	S _c in ³	I _{av} in ⁴	φM _{no} in.k	φV _{nt} lbs.	Max Unshored Span, ft.			A _{wvf} in ² /ft
										1 span	2 span	3 span	
22 gage	5.50	62.44	37.6	0.333	38	1.25	7.5	42.68	4820	8.59	10.83	11.19	0.023
	6.00	70.94	42.0	0.375	43	1.44	9.6	49.11	5130	8.20	10.26	10.69	0.027
	6.25	75.19	44.3	0.396	46	1.54	10.8	52.43	5290	8.03	9.88	10.29	0.029
	6.50	79.44	46.6	0.417	48	1.64	12.1	55.80	5450	7.86	9.52	9.92	0.032
	7.00	87.94	51.3	0.458	53	1.84	14.9	62.72	5780	7.57	8.88	9.25	0.036
	7.25	92.19	53.8	0.479	55	1.94	16.5	66.24	5960	7.43	8.60	8.95	0.038
	7.50	96.44	56.3	0.500	58	2.05	18.2	69.80	6130	7.28	8.33	8.67	0.041
20 gage	8.00	104.94	61.3	0.542	62	2.26	21.9	77.02	6480	6.81	7.83	8.16	0.045
	5.50	74.69	37.6	0.333	38	1.50	8.1	51.02	5250	10.10	12.48	12.89	0.023
	6.00	85.06	42.0	0.375	43	1.72	10.4	58.71	5870	9.63	11.66	12.15	0.027
	6.25	90.25	44.3	0.396	46	1.84	11.6	62.69	6180	9.42	11.23	11.69	0.029
	6.50	95.43	46.6	0.417	48	1.96	13.0	66.74	6510	9.23	10.83	11.28	0.032
	7.00	105.80	51.3	0.458	53	2.20	16.0	75.06	7000	8.87	10.10	10.52	0.036
	7.25	110.99	53.8	0.479	55	2.33	17.7	79.30	7180	8.71	9.78	10.18	0.038
19 gage	7.50	116.17	56.3	0.500	58	2.46	19.5	83.59	7350	8.56	9.47	9.86	0.041
	8.00	126.54	61.3	0.542	62	2.71	23.5	92.31	7700	8.12	8.91	9.28	0.045
	5.50	85.36	37.6	0.333	38	1.71	8.6	58.43	5250	11.44	13.69	14.15	0.023
	6.00	97.43	42.0	0.375	43	1.97	11.0	67.24	5870	10.90	13.14	13.58	0.027
	6.25	103.46	44.3	0.396	46	2.11	12.3	71.80	6180	10.66	12.89	13.33	0.029
	6.50	109.50	46.6	0.417	48	2.24	13.8	76.46	6510	10.44	12.66	13.08	0.032
	7.00	121.57	51.3	0.458	53	2.52	17.0	86.01	7170	10.03	12.22	12.63	0.036
18 gage	7.25	127.60	53.8	0.479	55	2.67	18.8	90.90	7510	9.84	12.02	12.42	0.038
	7.50	133.64	56.3	0.500	58	2.81	20.7	95.84	7860	9.67	11.83	12.22	0.041
	8.00	145.71	61.3	0.542	62	3.11	24.9	105.89	8570	9.39	11.47	11.85	0.045
	5.50	95.58	37.6	0.333	38	1.92	9.1	65.67	5250	12.48	14.62	15.11	0.023
	6.00	109.35	42.0	0.375	43	2.21	11.6	75.56	5870	11.89	14.05	14.52	0.027
	6.25	116.24	44.3	0.396	46	2.36	13.0	80.70	6180	11.62	13.78	14.24	0.029
	6.50	123.12	46.6	0.417	48	2.52	14.5	85.94	6510	11.38	13.53	13.99	0.032
16 gage	7.00	136.89	51.3	0.458	53	2.83	17.9	96.72	7170	10.93	13.07	13.51	0.036
	7.25	143.78	53.8	0.479	55	3.00	19.7	102.24	7510	10.72	12.86	13.29	0.038
	7.50	150.66	56.3	0.500	58	3.16	21.7	107.82	7860	10.53	12.65	13.08	0.041
	8.00	164.43	61.3	0.542	62	3.50	26.1	119.18	8570	10.23	12.27	12.68	0.045
	5.50	95.58	37.6	0.333	38	2.34	10.0	65.67	5250	13.92	16.38	16.31	0.023
	6.00	109.35	42.0	0.375	43	2.70	12.7	75.56	5870	13.50	15.74	15.87	0.027
	6.25	116.24	44.3	0.396	46	2.88	14.3	80.70	6180	13.19	15.44	15.67	0.029
16 gage	6.50	123.12	46.6	0.417	48	3.08	15.9	85.94	6510	12.91	15.17	15.49	0.032
	7.00	136.89	51.3	0.458	53	3.47	19.6	96.72	7170	12.40	14.66	15.15	0.036
	7.25	143.78	53.8	0.479	55	3.67	21.7	102.24	7510	12.16	14.42	14.90	0.038
	7.50	150.66	56.3	0.500	58	3.87	23.8	107.82	7860	11.94	14.19	14.67	0.041
	8.00	164.43	61.3	0.542	62	4.29	28.6	119.18	8570	11.60	13.77	14.23	0.045

Note:
50 ksi material is also available.
See website for load tables.

3" LOK-FLOOR - LW



3" LOK-FLOOR

3" x 12" deck $F_y = 40$ ksi $f'_c = 3$ ksi 115 pcf concrete

	Slab Depth	ϕM_n in.k	Span "L" feet, Uniform Live Unfactored Service Loads, psf												
			9.00	9.50	10.00	10.50	11.00	11.50	12.00	12.50	13.00	13.50	14.00	14.50	15.00
22 gage	5.50	62.44	290	260	230	205	185	165	150	135	125	115	105	95	85
	6.00	70.94	330	295	260	235	210	190	170	155	140	130	115	105	100
	6.25	75.19	350	310	280	250	225	200	180	165	150	135	125	115	105
	6.50	79.44	370	330	295	265	235	215	195	175	160	145	130	120	110
	7.00	87.94	400	365	325	290	260	235	215	195	175	160	145	135	120
	7.25	92.19	400	385	340	305	275	250	225	205	185	170	155	140	130
	7.50	96.44	400	400	355	320	290	260	235	215	195	175	160	145	135
	8.00	104.94	400	400	390	350	315	285	255	230	210	190	175	160	145
20 gage	5.50	74.69	355	315	280	250	225	205	185	170	155	140	130	115	105
	6.00	85.06	400	360	320	290	260	235	210	195	175	160	145	135	125
	6.25	90.25	400	380	340	305	275	250	225	205	185	170	155	145	130
	6.50	95.43	400	400	360	325	290	265	240	215	200	180	165	150	140
	7.00	105.80	400	400	400	360	325	290	265	240	220	200	185	170	155
	7.25	110.99	400	400	400	375	340	305	280	255	230	210	195	175	165
	7.50	116.17	400	400	400	395	355	320	290	265	240	220	200	185	170
	8.00	126.54	400	400	400	400	385	350	320	290	265	240	220	205	185
19 gage	5.50	85.36	400	365	325	290	265	240	215	195	170	155	140	125	110
	6.00	97.43	400	400	370	335	300	275	250	225	205	190	175	160	145
	6.25	103.46	400	400	395	355	320	290	265	240	220	200	185	170	155
	6.50	109.50	400	400	400	375	340	305	280	255	230	215	195	180	165
	7.00	121.57	400	400	400	400	375	340	310	285	260	235	215	200	185
	7.25	127.60	400	400	400	400	395	360	325	295	270	250	230	210	195
	7.50	133.64	400	400	400	400	400	375	340	310	285	260	240	220	205
	8.00	145.71	400	400	400	400	400	400	375	340	310	285	260	240	220
18 gage	5.50	95.58	400	400	365	330	300	260	230	205	180	160	145	130	120
	6.00	109.35	400	400	400	380	340	310	280	255	230	205	185	165	150
	6.25	116.24	400	400	400	400	365	330	300	275	250	230	210	185	170
	6.50	123.12	400	400	400	400	385	350	320	290	265	245	225	205	190
	7.00	136.89	400	400	400	400	400	390	355	325	295	270	250	230	210
	7.25	143.78	400	400	400	400	400	400	375	340	310	285	260	240	225
	7.50	150.66	400	400	400	400	400	400	390	355	325	300	275	255	235
	8.00	164.43	400	400	400	400	400	400	400	390	355	325	300	275	255
16 gage	5.50	95.58	400	400	365	330	300	260	230	205	180	160	145	130	120
	6.00	109.35	400	400	400	380	340	310	280	255	230	205	185	165	150
	6.25	116.24	400	400	400	400	365	330	300	275	250	230	210	185	170
	6.50	123.12	400	400	400	400	385	350	320	290	265	245	225	205	190
	7.00	136.89	400	400	400	400	400	390	355	325	295	270	250	230	210
	7.25	143.78	400	400	400	400	400	400	375	340	310	285	260	240	225
	7.50	150.66	400	400	400	400	400	400	390	355	325	300	275	255	235
	8.00	164.43	400	400	400	400	400	400	400	390	355	325	300	275	255
22 gage	5.50	42.68	190	165	150	130	115	105	95	85	75	70	60	55	50
	6.00	49.11	220	195	170	150	135	120	110	95	85	80	70	65	55
	6.25	52.43	235	205	185	165	145	130	115	105	95	85	75	70	60
	6.50	55.80	250	220	195	175	155	140	125	110	100	90	80	75	65
	7.00	62.72	280	250	220	195	175	155	140	125	115	105	95	85	75
	7.25	66.24	300	265	235	210	185	165	150	135	120	110	100	90	80
	7.50	69.80	315	280	245	220	195	175	160	140	130	115	105	95	85
	8.00	77.02	350	310	275	245	215	195	175	155	140	130	115	105	95
20 gage	5.50	51.02	230	205	180	165	145	130	115	105	95	85	80	70	65
	6.00	58.71	270	235	210	190	170	150	135	125	110	100	90	80	75
	6.25	62.69	285	255	225	200	180	160	145	130	120	110	100	90	80
	6.50	66.74	305	270	240	215	190	175	155	140	125	115	105	95	85
	7.00	75.06	345	305	270	245	215	195	175	160	145	130	120	110	100
	7.25	79.30	365	325	290	255	230	205	185	170	155	140	125	115	105
	7.50	83.59	385	340	305	270	245	220	195	180	160	145	135	120	110
	8.00	92.31	400	380	335	300	270	245	220	200	180	165	150	135	125
19 gage	5.50	58.43	270	240	215	190	170	155	140	125	115	105	95	85	80
	6.00	67.24	310	275	245	220	195	180	160	145	130	120	110	100	90
	6.25	71.80	335	295	265	235	210	190	170	155	140	130	115	105	95
	6.50	76.46	355	315	280	250	225	205	185	165	150	135	125	115	105
	7.00	86.01	400	355	315	285	255	230	210	190	170	155	140	130	120
	7.25	90.90	400	375	335	300	270	245	220	200	180	165	150	135	125
	7.50	95.84	400	400	355	315	285	255	230	210	190	175	160	145	135
	8.00	105.89	400	400	395	350	315	285	260	235	215	195	175	160	150
18 gage	5.50	65.67	305	270	245	215	195	175	160	145	130	120	110	100	90
	6.00	75.56	355	315	280	250	225	205	185	165	150	140	125	115	105
	6.25	80.70	380	335	300	270	240	220	195	180	165	150	135	125	115
	6.50	85.94	400	360	320	285	260	235	210	190	175	160	145	130	120
	7.00	96.72	400	400	360	325	290	265	240	215	195	180	165	150	140
	7.25	102.24	400	400	385	345	310	280	250	230	210	190	175	160	145
	7.50	107.82	400	400	400	360	325	295	265	240	220	200	185	170	155
	8.00	119.18	400	400	400	400	360	325	295	270	245	225	205	185	170
16 gage	5.50	65.67	305	270	245	215	195	175	160	145	130	120	110	100	90
	6.00	75.56	355	315	280	250	225	205	185	165	150	140	125	115	105
	6.25	80.70	380	335	300	270	240	220	195	180	165	150	135	125	115
	6.50	85.94	400	360	320	285	260	235	210	190	175	160	145	130	120
	7.00	96.72	400	400	360	325	290	265	240	215	195	180	165	150	140
	7.25	102.24	400	400	385	345	310	280	250	230	210	190	175	160	145
	7.50	107.82	400	400	400	360	325	295	265	240	220	200	185	170	155
	8.00	119.18	400	400	400	400	360	325	295	270	245	225	205	185	170

Studs at 1 foot o.c.

No Studs

Minimum bearing on deck for all accessories shall be 2". Pour stops, cell closures, finish strips, girder filler, J, and Z-closures, and column closures shall be furnished ONLY when ordered by the purchaser and/or specifically shown on the contract documents.

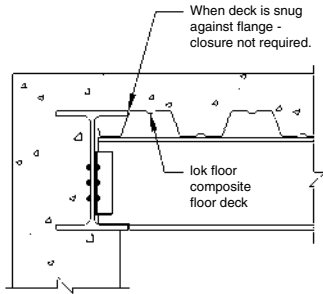

A

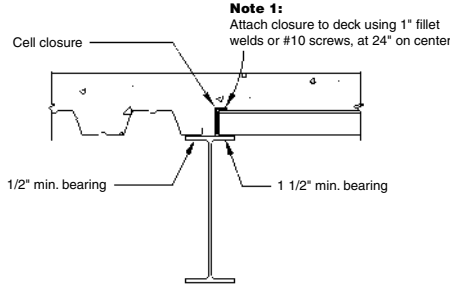

B

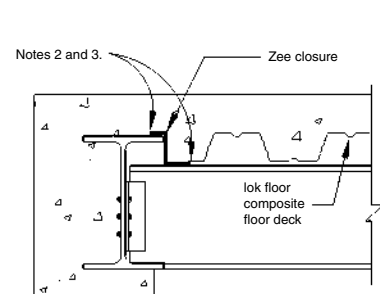

C

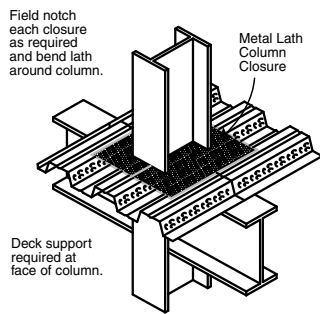

D

COLUMN CLOSURE DETAIL

Note 2:
Attach closure to deck or deck to closure using 1" fillet welds or #10 screws and matching deck side lap fastener spacing or 24" o.c. maximum.

Attach closure to deck using 1" fillet welds at 24" o.c.

COMPOSITE FINISH STRIP
(Furnished at the option of deck supplier to avoid field cutting.)

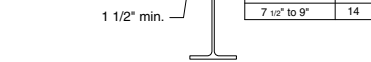

E

GAP	GAGE
0 to 5"	20
5 to 7 1/2"	16
7 1/2" to 9"	14

Note 3:
Attach closure to steel supports using 1" fillet welds and matching deck sidelap fastener spacing or 24" o.c. maximum.

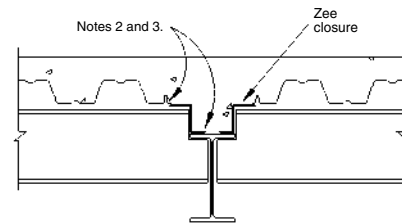

F

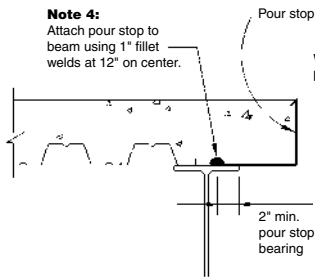

G

Where sections of pour stop butt:
1. Provide a 1" long weld at the top of the vertical leg.
2. Provide a 1" long weld at the midspan of horizontal leg where pourstop overhangs more than 7" from support, and at 7" on center for greater overhangs.

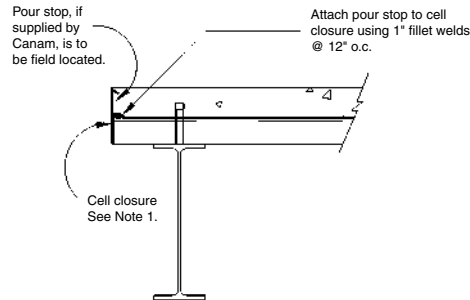

H

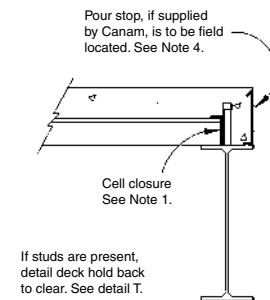

I

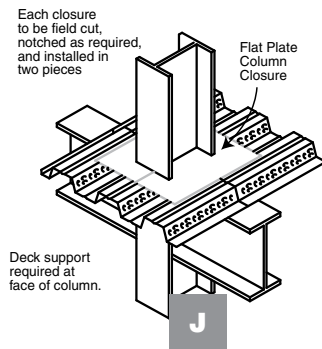

J

COLUMN CLOSURE DETAIL

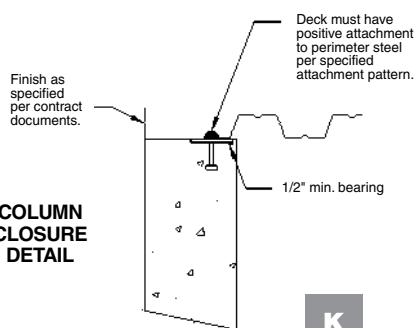

K

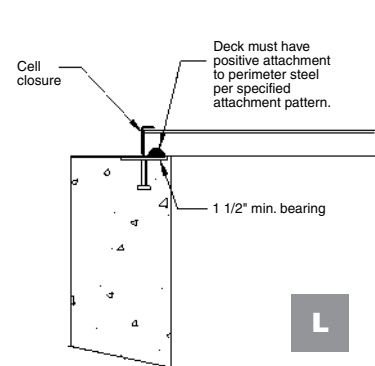

L

DETAILS

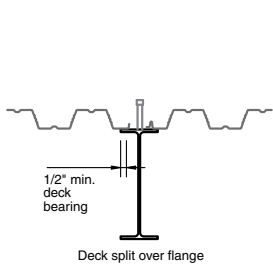

M

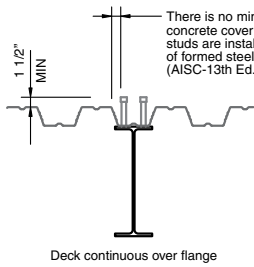

N

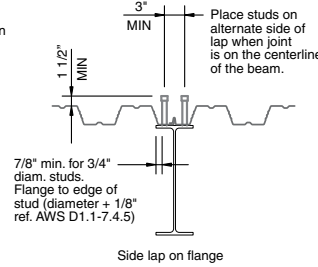

O

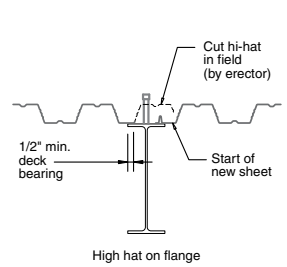

P

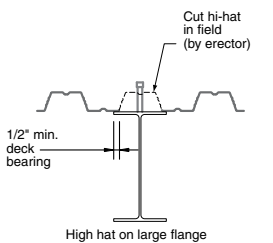

Q

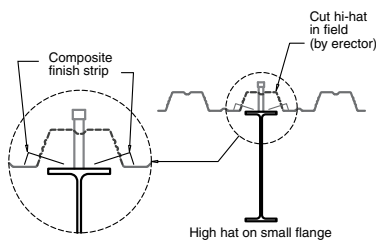

R

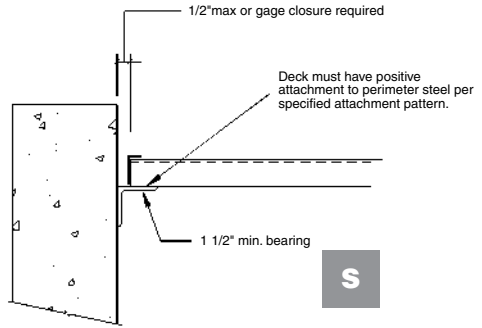

S

TYPICAL NON-CONTINUOUS CLOSURE DETAIL N.T.S

ERECTOR NOTE: Cell closure may interfere with shear stud installation at perimeter beam. If this occurs, erector may choose to pre cut 7" long cell closure from 10'-0" pieces provided or pre-order 7" long closure pieces (mark FCC...) and install at high flutes as shown or, erector may choose to first pre-install continuous cell closure and then notch closure at low flutes where needed.

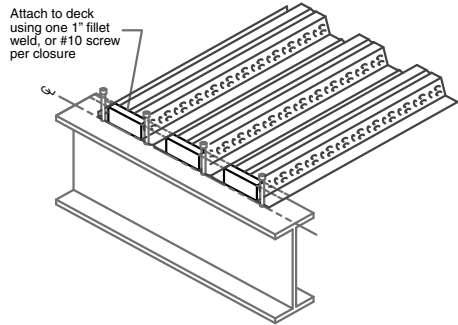

T

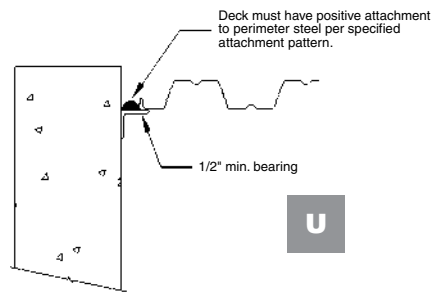

U

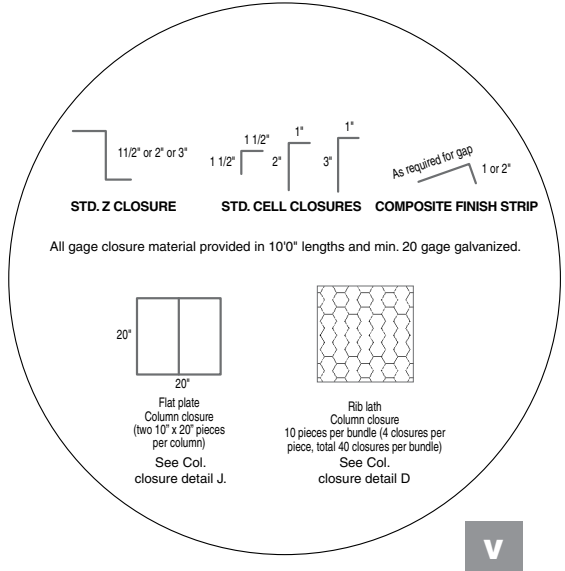

V

BUTT JOINT

0" min., 1" max. Closure is not required for a gap of 1/2" or less. When needed, closure not by Canam.

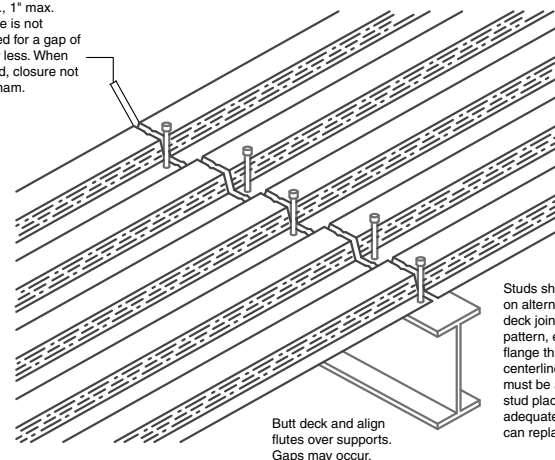

W

All LOK-Floor is furnished in 24 inch or 36 inch widths. Any cutting that is required shall be done in the field by deck erector.

DETAILS

Q_n (kips) for Studs in Steel Deck - LRFD*															
Profile	W _r in.	Concrete Density pcf	Studs per Corr.	3/4" φ Shear Stud's Avg. Nominal Shear Strength/Stud in a Deck Corrugation						1/2" φ Shear Stud's Avg. Nominal Shear Strength/Stud in a Deck Corrugation					
				Perpendicular to Beam			Parallel to Beam			Perpendicular to Beam			Parallel to Beam		
				f'c Concrete Compressive Strength, ksi											
				3.0	3.5	4.0	3.0	3.5	4.0	3.0	3.5	4.0	3.0	3.5	4.0
Solid Concrete	NA	145	NA	21.0	23.6	26.1	21.0	23.6	26.1	9.4	10.5	11.6	9.4	10.5	11.6
		115		17.7	19.8	21.9	17.7	19.8	21.9	7.9	8.8	9.8	7.9	8.8	9.8
B-LOK	2.125	145	1	17.2			18.3			7.7			8.1		
			2	14.6						6.5					
			3	12.1						5.4					
		115	1	17.2			17.7	18.3	18.3	7.7			8.1		
			2	14.6						6.5					
			3	12.1						5.4					
LOK FLOOR 1.5", 2", 3"	6	145	1	17.2			21.0	21.5	21.5	7.7			9.4	9.6	9.6
			2	16.5						7.3					
			3	13.1						5.8					
Inverted B-LOK	3.875	115	1	17.2			17.7	19.8	21.5	7.7			7.9	8.8	9.6
			2	16.5						7.2	7.3	7.3			
			3	13.1						5.8					

* Section I3.2c of ANSI/AISC 360-05 Specification for Structural Steel Buildings in the AISC Steel Construction Manual, 13th Edition.

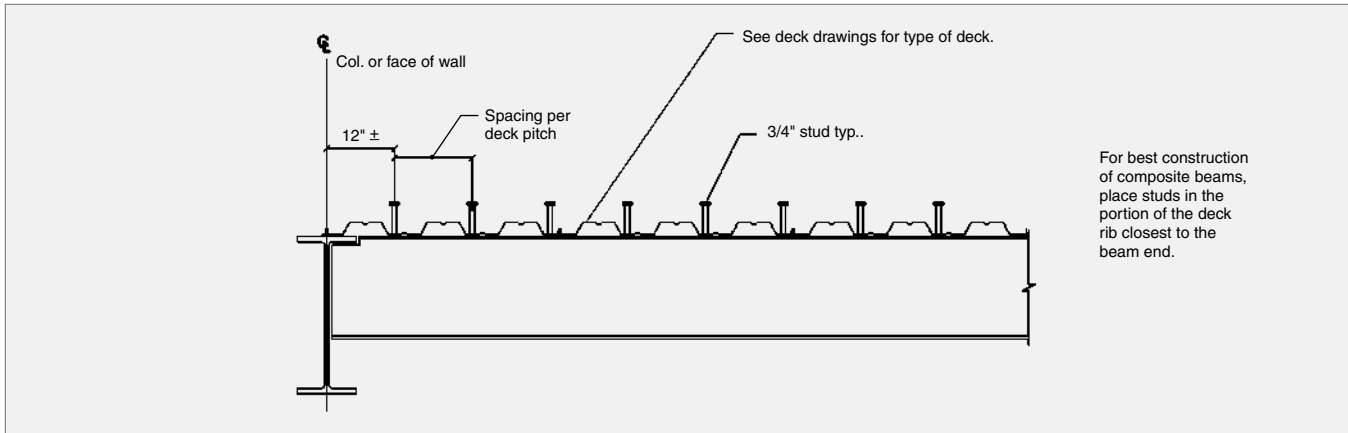

FIGURE 1

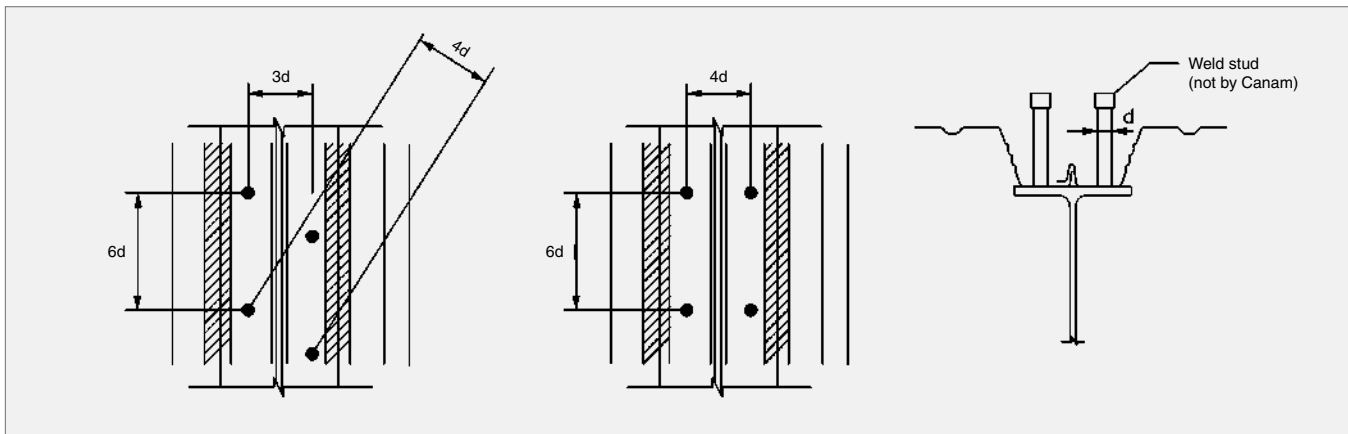

FIGURE 2

COMPOSITE BEAM AND JOIST DETAILS

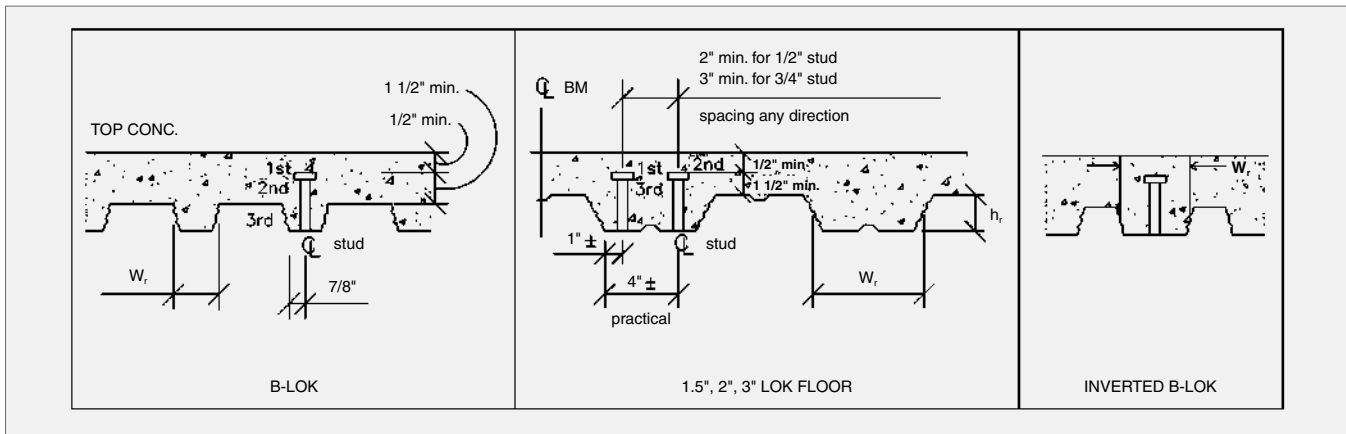

FIGURE 3

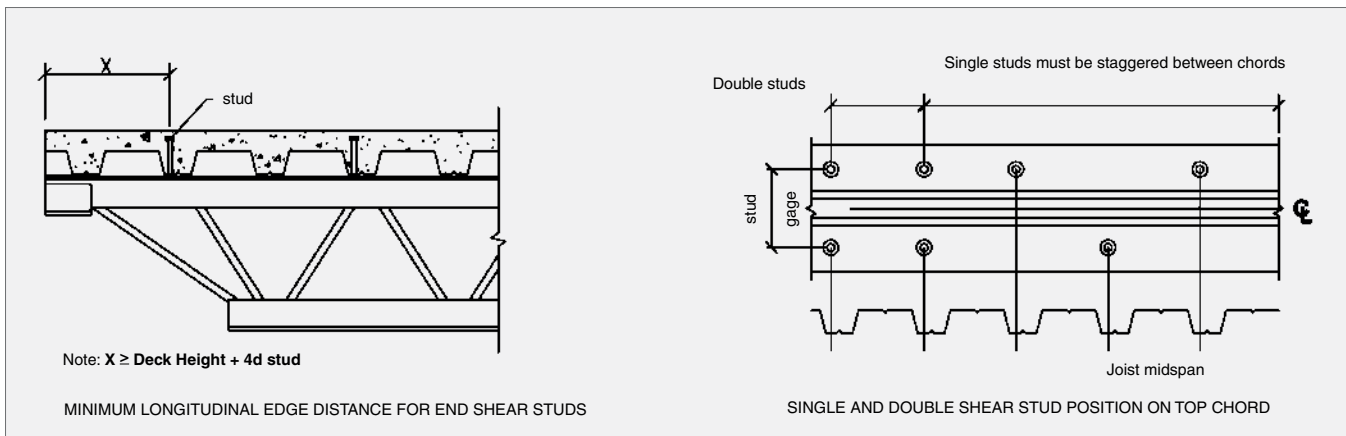
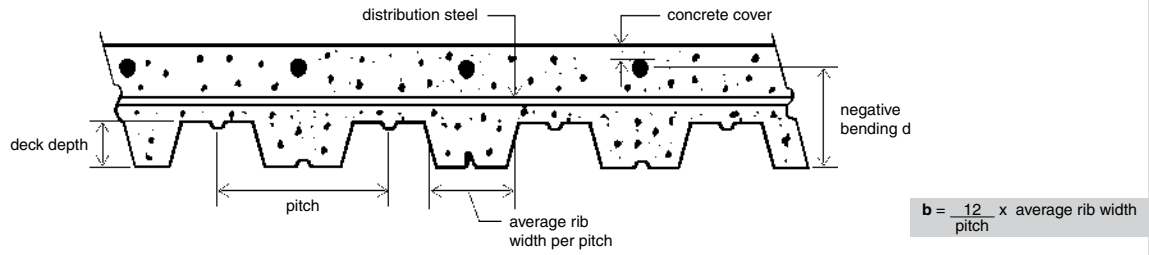

FIGURE 4

1. The preferred positive bending stud location is closest to beam ends in each corrugation with studs – Figures 1 and 4.
2. Table assumes that the first stud will be located in the weak location, the second in the strong location, and the third in the weak location. Figure 3 shows this conservative model and “non-preferred” condition. All studs through B-LOK are in the weak location.
3. W_r = average width of rib ≥ 2 in. When deck is parallel to beam, $w_r \geq 2$ in. + 3D for 2 studs across a corrugation. For multiple 3/4” studs in Inverted B-LOK, split the deck when parallel to beam. See values perpendicular to beam.
4. h_r = height of rib ≤ 3 ”.
5. Density = 145 PCF conforms to ASTM C33; 115 PCF conforms to ASTM C330.
6. Studs conform to ANSI / AWS D1.1 with $F_u = 65$ ksi.
7. When deck is parallel to the beam: a) The minimum center-to-center spacing of studs installed along the beam is 6 diameters (4 1/2”, 3”.) b) When w_r is wide enough, we suggest that studs be staggered either side of the corrugation. The minimum stagger transverse dimension is 3 diameters (2 1/4”, 1 1/2”) and center to center dimension is 4 diameters (3”, 2”.) c) Deck may be split over beams. d) When studs are side-by-side, the minimum transverse spacing is 4 diameters. See Figures 2 and 4.
8. The maximum center-to-center spacing of studs shall not exceed 8 x total slab thickness or 36 in.
9. 3/4” diameter studs are typical on beams. 1/2” or 3/4” diameter studs are commonly used on open web steel joists. See Figure 4.

COMPOSITE BEAM AND JOIST DETAILS

Negative Bending Information



Deck Section	Pitch	Average Rib Width	b Width for Negative Bending
B-LOK	6"	2.25"	4.5"
Inverted B-LOK	6"	3.75"	7.5"
Lok Floor	12"	6"	6"
N-Lok	8"	2.25"	3.375"

Use Standard concrete design procedures as per ACI.

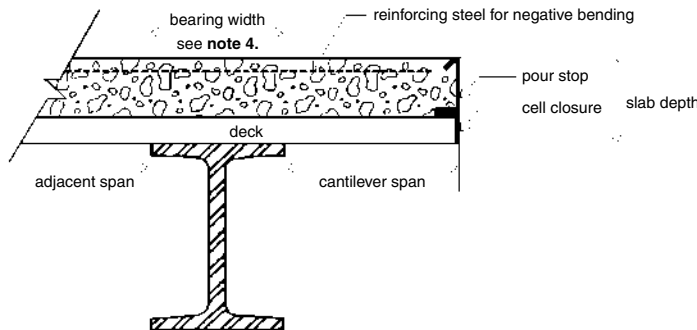

1. Table uses the SDI single span loading combinations and loading including a concentrated load at the end.
2. Table is LRFD based. Factored resistance values are shown in the slab load tables.
3. Cantilever deflection limits are: cantilever/90 and 3/4 inch. Table is based on a multi-span condition with back span equal to twice the cantilever.
4. Web crippling considers 5 inch bearing and a back span of three times the cantilever. SDI concentrated load is located over the beam.
5. Fasten all corrugations at spandrel beam and first interior beam. Fasten side laps at 12" o.c. at the cantilever.
6. When Inverted B-LOK is used, use the cantilever values for B-LOK.

Note:
F_y = 40 ksi

Floor Deck Cantilevers

Slab Depth	Normal Weight Concrete (150 PCF)																			
	B-LOK				1.5 LOK-FLOOR				2.0 LOK-FLOOR				N-LOK				3.0 LOK-FLOOR			
	Gage				Gage				Gage				Gage				Gage			
	22	20	18	16	22	20	18	16	22	20	18	16	22	20	18	16	22	20	18	16
4.00"	2'0"	2'4"	2'11"	3'5"	2'0"	2'5"	3'2"	3'9"	2'6"	3'1"	3'11"	4'6"								
4.50"	1'11"	2'3"	2'9"	3'3"	1'11"	2'4"	3'0"	3'6"	2'5"	2'11"	3'9"	4'4"								
5.00"	1'10"	2'2"	2'8"	3'3"	1'10"	2'3"	2'11"	3'5"	2'4"	2'10"	3'6"	4'2"	3'6"	4'1"	5'1"	5'9"	3'6"	4'2"	5'1"	5'5"
5.50"	1'9"	2'2"	2'7"	3'0"	1'10"	2'2"	2'10"	3'3"	2'3"	2'9"	3'5"	3'11"	3'4"	3'11"	4'10"	5'7"	3'4"	4'0"	4'10"	5'3"
6.00"	1'9"	2'1"	2'6"	2'11"	1'9"	2'2"	2'9"	3'2"	2'2"	2'8"	3'4"	3'10"	3'2"	3'9"	4'7"	5'4"	3'2"	3'9"	4'8"	5'1"
6.50"	1'9"	2'0"	2'5"	2'10"	1'9"	2'1"	2'8"	3'1"	2'2"	2'7"	3'3"	3'9"	3'1"	3'7"	4'5"	5'1"	3'0"	3'6"	4'6"	5'0"
7.00"	1'8"	2'0"	2'5"	2'10"	1'8"	2'1"	2'8"	3'1"	2'1"	2'6"	3'2"	3'8"	2'11"	3'5"	4'3"	4'11"	2'10"	3'4"	4'4"	4'10"
7.50"	1'8"	1'11"	2'4"	2'9"	1'7"	2'0"	2'7"	3'0"	2'1"	2'6"	3'1"	3'7"	2'11"	3'4"	4'1"	4'9"	2'8"	3'1"	4'3"	4'9"
8.00"	1'8"	1'11"	2'4"	2'9"	1'6"	2'0"	2'6"	2'11"	2'0"	2'5"	3'0"	3'6"	2'10"	3'3"	4'0"	4'8"	2'6"	2'11"	4'2"	4'8"

NEGATIVE BENDING INFORMATION

Pour Stop Selection Chart

Slab Depth (inches)	Overhang (inches)												
	0	1	2	3	4	5	6	7	8	9	10	11	12
4.00	20	20	20	20	18	18	16	14	12	12	12	10	10
4.25	20	20	20	18	18	16	16	14	12	12	12	10	10
4.50	20	20	20	18	18	16	16	14	12	12	12	10	10
4.75	20	20	18	18	16	16	14	14	12	12	10	10	10
5.00	20	20	18	18	16	16	14	14	12	12	10	10	
5.25	20	18	18	16	16	14	14	12	12	12	10	10	
5.50	20	18	18	16	16	14	14	12	12	12	10	10	
5.75	20	18	16	16	14	14	12	12	12	12	10	10	
6.00	18	18	16	16	14	14	12	12	12	10	10	10	
6.25	18	18	16	14	14	12	12	12	12	10	10		
6.50	18	16	16	14	14	12	12	12	12	10	10		
6.75	18	16	14	14	14	12	12	12	10	10	10		
7.00	18	16	14	14	12	12	12	12	10	10	10		
7.25	16	16	14	14	12	12	12	10	10	10			
7.50	16	14	14	12	12	12	12	10	10	10			
7.75	16	14	14	12	12	12	10	10	10	10			
8.00	14	14	12	12	12	12	10	10	10				
8.25	14	14	12	12	12	10	10	10	10				
8.50	14	12	12	12	12	10	10	10					
8.75	14	12	12	12	12	10	10	10					
9.00	14	12	12	12	10	10	10						
9.25	12	12	12	12	10	10	10						
9.50	12	12	12	10	10	10							
9.75	12	12	12	10	10	10							
10.00	12	12	10	10	10	10							
10.25	12	12	10	10	10								
10.50	12	12	10	10	10								
10.75	12	10	10	10									
11.00	12	10	10	10									
11.25	12	10	10										
11.50	10	10	10										
11.75	10	10											
12.00	10	10											

Type	20	18	16	14	12	10
Design Thickness	0.0358	0.0474	0.0598	0.0747	0.1046	0.1345

Optional Hanger Accessories

Allowable load per tab: 100 lbs.

Non-piercing and Integral tabs are for light ceiling loads.

NON-PIERCING HANGER TAB

#12 wire minimum.
Allowable load per tab: 100 lbs.
Can accommodate 1/4" φ rod (N.Y.C. Requirement).
Available in 16, 18, and 20 gage (deck thickness).
NOT FOR SUSPENDED PLASTER CEILINGS OR WALKWAYS.

INTEGRAL HANGER TAB

STIFFENED POUR STOP

Canam supplied angles are to be field cut and the assembly is to be field welded. Shop installation of stiffener angles is available at an additional cost. Consult your Canam sales representative for cost and lead time information. Stiffener spacing and size may vary from example shown.

This Selection Chart is based on following criteria:

1. Normal weight concrete (150 PCF).
2. Horizontal and vertical deflection is limited to 1/4" maximum for concrete dead load.
3. Design stress is limited to 20 KSI for concrete dead load temporarily increased by one-third for the construction live load of 20 PSF.
4. Pour Stop Selection Chart does not consider the effect of the performance, deflection, or rotation of the pour stop support which may include both the supporting composite deck and/or the frame.
5. Vertical leg return lip is recommended for all types and gages (1" on 10 gage, 3/4" on 12 gage, all others 1/2").
6. This selection is not meant to replace the judgement of experienced Structural Engineers and shall be considered as a reference only.
7. A stiffened pour stop may be used when overhang and or slab depth checks in this chart are exceeded. Consult with Canam Engineering.

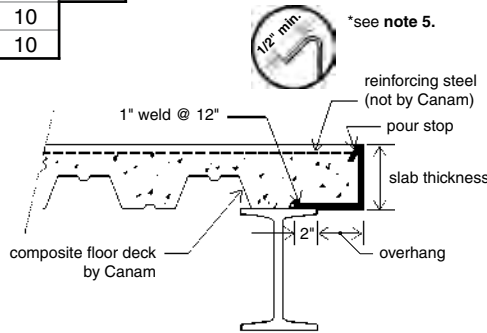

POUR STOP, HANGERS



	Section	Gage	I	S _p	S _n	φV, lbs.	Weight, psf
LFCS3	<p>17.7 in.² per cell 24" cover</p>	20/20	1.54	0.66	0.65	3220	3.5
		20/18	1.65	0.66	0.68	3220	4
		18/20	1.90	0.93	0.85	4880	4.5
		18/18	2.04	0.94	0.88	4880	5
		18/16	2.16	0.96	0.91	4880	5.5
		16/18	2.44	1.17	1.09	6130	5.5
		16/16	2.59	1.19	1.13	6130	6
NLCS	<p>17.4 in.² per cell 24" cover</p>	20/20	1.45	0.60	0.71	5020	4.5
		20/18	1.58	0.60	0.86	5020	5
		18/20	1.97	0.88	0.88	6980	5
		18/18	2.13	0.90	1.04	6980	5.5
		18/16	2.28	0.91	1.28	6980	6
		16/18	2.74	1.24	1.22	8770	6.5
		16/16	2.94	1.26	1.46	8770	7
LFCS2	<p>11.7 in.² per cell 24" cover</p>	20/20	0.64	0.40	0.40	2410	3.5
		20/18	0.69	0.41	0.41	2410	4
		18/20	0.79	0.56	0.52	3180	4
		18/18	0.85	0.58	0.53	3180	4.5
		18/16	0.90	0.58	0.55	3180	5
		16/18	1.02	0.72	0.66	3990	5
		16/16	1.08	0.73	0.69	3990	5.5
LFCS1.5	<p>8.7 in.² per cell 24" cover</p>	20/20	0.35	0.29	0.28	1890	3.5
		20/18	0.37	0.29	0.29	1890	4
		18/20	0.43	0.40	0.36	2490	4
		18/18	0.46	0.41	0.38	2490	4.5
		18/16	0.49	0.42	0.40	2490	4.5
		16/18	0.56	0.51	0.47	3130	5
		16/16	0.59	0.52	0.49	3130	5.5
BLCS	<p>6 in.² per cell 24" cover</p>	20/20	0.38	0.30	0.31	3170	3.5
		20/18	0.41	0.31	0.39	3170	4
		18/20	0.52	0.45	0.40	4160	4.5
		18/18	0.56	0.46	0.47	4160	5
		18/16	0.60	0.47	0.55	4160	5.5
		16/18	0.71	0.64	0.56	5210	5.5
		16/16	0.77	0.65	0.68	5210	6

Canam does not produce electrified floor systems but cellular deck is used in blended systems with electrified components of other manufacturers.

Check List for Cellular Deck

- ✓ Uniform load tables for BLCS and NLCS cellular deck are shown in the roof deck section. When used as a concrete form, the increased strength and stiffness relative to the non-cellular top element can be used. Use the maximum un-shored span calculator on the Canam web site; input F_y = 33 ksi. It is acceptable to use the composite deck tables for the 40 ksi top element while neglecting the bottom liner.
- ✓ The composite deck concrete slab uniform load capacity defaults to the slab capacity of the top element, e.g. LFCS2 20/18 use LF2 20 gage
- ✓ Cellular deck is not covered in fire rated roof assemblies and spray proofing can not be applied directly. Cellular deck is listed in several fire-rated floor assemblies. Galvanized steel is always required for cellular deck in rated assemblies.
- ✓ LFCS2 and LFCS3 are available with a 36" cover by special order only.
- ✓ Light gage cellular deck subjected to high concentrated loads may require additional spot welds to resist shear forces in the deck.

Acoustic Composite Cellular Deck

Type LFCAS2 and LFCAS3 are available for composite slabs. Consult Canam Engineering or your local sales office for additional information. Acoustic deck is not addressed in fire rated assemblies.

CELLULAR FLOOR DECK

U.L. Design No	F.P.	Concrete Cover and Type	Canam Product
D215	S	2 1/2" NW	BL, BLC
D216	S	2 1/2" NW,LW	BL,BLC,LF2,LF2C,LF3,LF3C,NL,NLC
D219	S	2 1/2" NW,LW	BL,BLC,LF2,LF2C,LF3,LF3C,NL,NLC
D503	S	2" NW	LF2, LF3, NL
D303	MFB	3 1/2" NW	BL,BLC,LF15,LCF15,LF2,LF2C,LF3,LF3C,NL,NLC
D303	MFB	2 5/8" LW	BL,BLC,LF15,LCF15,LF2,LF2C,LF3,LF3C,NL,NLC
D703	SFRM	2 1/2" NW, LW	BL,BLC,LF15,LCF15,LF2,LF2C,LF3,LF3C,NL,NLC*
D712	SFRM	2 1/2" NW,LW	BL,BLC,LF15,LCF15,LF2,LF2C,LF3,LF3C,NL,NLC*
D722	SFRM	2 1/2" NW,LW	BL,BLC,LF15,LCF15,LF2,LF2C,LF3,LF3C,NL,NLC*
D739	SFRM	2 1/2" NW,LW	BL,BLC,LF15,LCF15,LF2,LF2C,LF3,LF3C,NL,NLC*
D743	SFRM	2" NW,LW	LF2, LF3*
D759	SFRM	2 1/2" NW,LW	BL,BLC,LF15,LCF15,LF2,LF2C,LF3,LF3C,NL,NLC*
D767	SFRM	2 1/2" NW,LW	BL,BLC,LF15,LCF15,LF2,LF2C,LF3,LF3C,NL,NLC*
D778	SFRM	2 1/2" LW	LF2, LF2C, LF3, LFC3
D778	SFRM	3" NW	LF2, LF2C, LF3, LFC3
D779	SFRM	2 1/2" NW,LW	BL,LF15,LF2,LF3*
D782	SFRM	3 1/4" LW	LF15,LF2,LF3,NL*
D787	SFRM	2 1/2" NW,LW	BL,BLC,LF15,LCF15,LF2,LF2C,LF3,LF3C,NL,NLC*
D788	SFRM	2 1/2" NW,LW	BL,BLC,LF15,LCF15,LF2,LF2C,LF3,LF3C,NL,NLC*
D832	SFRM	2 1/2" NW,LW	BL,BLC,LF15,LCF15,LF2,LF2C,LF3,LF3C,NL,NLC*
D847	SFRM	2 1/2" NW,LW	LF2,LF2C,LF3,LF3C,NL,NLC*
D858	SFRM	2 1/2" NW,LW	LF2,LF2C,LF3,LF3C*
D859	SFRM	2" NW,LW	LF2,LF2C,LF3,LF3C*
D902	N	3 1/2" NW	BL,BLC,LF15,LCF15,LF2,LF2C,LF3,LF3C,NL,NLC
D902	N	2 1/2" LW	BL,BLC,LF15,LCF15,LF2,LF2C,LF3,LF3C,NL,NLC
D902	N	2 5/8" LW	BL,BLC,LF15,LCF15,LF2,LF2C,LF3,LF3C,NL,NLC
D914	N	2 1/2" LW	BL,BLC,LF15,LCF15,LF2,LF2C,LF3,LF3C,NL,NLC
D916	N	3 1/2" NW	BL,BLC,LF15,LCF15,LF2,LF2C,LF3,LF3C,NL,NLC
D916	N	2 1/2" LW	BL,BLC,LF15,LCF15,LF2,LF2C,LF3,LF3C,NL,NLC
D916	N	2 5/8" LW	BL,BLC,LF15,LCF15,LF2,LF2C,LF3,LF3C,NL,NLC
D918	N	3 1/2" NW	LF15,LCF15,LF2,LF2C,LF3,LF3C,NL,NLC
D918	N	2 1/2" LW	LF15,LCF15,LF2,LF2C,LF3,LF3C,NL,NLC
D919	N	3 1/2" NW	LF15,LCF15,LF2,LF2C,LF3,LF3C,NL,NLC
D919	N	2 1/2" LW	LF15,LCF15,LF2,LF2C,LF3,LF3C,NL,NLC
D922	N	3 1/2" NW	BL,BLC,LF15,LCF15,LF2,LF2C,LF3,LF3C,NL,NLC
D922	N	2 5/8" LW	BL,BLC,LF15,LCF15,LF2,LF2C,LF3,LF3C,NL,NLC
D923	N	3 1/2" NW	BL,BLC,LF15,LCF15,LF2,LF2C,LF3,LF3C,NL,NLC
D923	N	2 5/8" LW	BL,BLC,LF15,LCF15,LF2,LF2C,LF3,LF3C,NL,NLC
D925	N	3 1/2" NW	BL,BLC,LF15,LCF15,LF2,LF2C,LF3,LF3C,NL,NLC
D925	N	2 5/8" LW	BL,BLC,LF15,LCF15,LF2,LF2C,LF3,LF3C,NL,NLC
D927	N	3 1/2" NW	BL,BLC,LF15,LCF15,LF2,LF2C,LF3,LF3C,NL,NLC
D927	N	2 5/8" LW	BL,BLC,LF15,LCF15,LF2,LF2C,LF3,LF3C,NL,NLC
D929	N	3 1/2" NW	BL,BLC,LF15,LCF15,LF2,LF2C,LF3,LF3C,NL,NLC
D929	N	2 1/2" LW	BL,BLC,LF15,LCF15,LF2,LF2C,LF3,LF3C,NL,NLC
D929	N	2 5/8" LW	BL,BLC,LF15,LCF15,LF2,LF2C,LF3,LF3C,NL,NLC
D931	N	3 1/2" NW	BL,BLC,LF15,LCF15,LF2,LF2C,LF3,LF3C,NL,NLC
D931	N	2 1/2" LW	BL,BLC,LF15,LCF15,LF2,LF2C,LF3,LF3C,NL,NLC
D931	N	2 5/8" LW	BL,BLC,LF15,LCF15,LF2,LF2C,LF3,LF3C,NL,NLC
D940	N	3 1/2" NW	BL, BLC, LF15, LFC15, LF2, LF2C, LF3, LFC3, NL,NLC,LS4.5
D940	N	2 1/2" LW	BL, BLC, LF15, LFC15, LF2, LF2C, LF3, LFC3, NL,NLC,LS4.5
D943	N	3 1/2" NW	BL,BLC,LF15,LCF15,LF2,LF2C,LF3,LF3C,NL,NLC
D943	N	2 5/8" LW	BL,BLC,LF15,LCF15,LF2,LF2C,LF3,LF3C,NL,NLC
D949	N	3 1/2" NW	BL,BLC,LF15,LCF15,LF2,LF2C,LF3,LF3C,NL,NLC
D949	N	2 5/8" LW	BL,BLC,LF15,LCF15,LF2,LF2C,LF3,LF3C,NL,NLC
D215	S	2 1/2" NW	BL, BLC
D216	S	2 1/2" NW,LW	BL,BLC,LF2,LF2C,LF3,LF3C,NL,NLC
D219	S	2 1/2" NW,LW	BL,BLC,LF2,LF2C,LF3,LF3C,NL,NLC
D303	MFB	4" NW	BL,BLC,LF15,LCF15,LF2,LF2C,LF3,LF3C,NL,NLC
D303	MFB	3" LW	BL,BLC,LF15,LCF15,LF2,LF2C,LF3,LF3C,NL,NLC
D502	S	2 1/2" NW	BL,BLC,LF2,LF2C,LF3,LF3C,NL,NLC
D703	SFRM	2 1/2" NW, LW	BL,BLC,LF15,LCF15,LF2,LF2C,LF3,LF3C,NL,NLC*
D712	SFRM	2 1/2" NW,LW	BL,BLC,LF15,LCF15,LF2,LF2C,LF3,LF3C,NL,NLC*
D722	SFRM	2 1/2" NW,LW	BL,BLC,LF15,LCF15,LF2,LF2C,LF3,LF3C,NL,NLC*
D739	SFRM	2 1/2" NW,LW	BL,BLC,LF15,LCF15,LF2,LF2C,LF3,LF3C,NL,NLC*
D743	SFRM	2" NW,LW	LF2, LF3
D759	SFRM	2 1/2" NW,LW	BL,BLC,LF15,LCF15,LF2,LF2C,LF3,LF3C,NL,NLC*
D767	SFRM	2 1/2" NW,LW	BL,BLC,LF15,LCF15,LF2,LF2C,LF3,LF3C,NL,NLC*
D778	SFRM	2 1/2" LW	LF2, LF2C, LF3, LFC3
D778	SFRM	3" NW	LF2, LF2C, LF3, LFC3
D779	SFRM	2 1/2" NW,LW	BL,LF15,LF2,LF3*
D782	SFRM	3 1/4" LW	LF15,LF2,LF3,NL*
D787	SFRM	2 1/2" NW,LW	BL,BLC,LF15,LCF15,LF2,LF2C,LF3,LF3C,NL,NLC*
D788	SFRM	2 1/2" NW,LW	BL,BLC,LF15,LCF15,LF2,LF2C,LF3,LF3C,NL,NLC*
D832	SFRM	2 1/2" NW,LW	BL,BLC,LF15,LCF15,LF2,LF2C,LF3,LF3C,NL,NLC*
D847	SFRM	2 1/2" NW,LW	LF2,LF2C,LF3,LF3C,NL,NLC*
D858	SFRM	2 1/2" NW,LW	LF2,LF2C,LF3,LF3C*
D859	SFRM	2" NW,LW	LF2,LF2C,LF3,LF3C*
D902	N	4" NW	BL,BLC,LF15,LCF15,LF2,LF2C,LF3,LF3C,NL,NLC
D902	N	3" LW	BL,BLC,LF15,LCF15,LF2,LF2C,LF3,LF3C,NL,NLC
D916	N	4" NW	BL,BLC,LF15,LCF15,LF2,LF2C,LF3,LF3C,NL,NLC
D916	N	3" LW	BL,BLC,LF15,LCF15,LF2,LF2C,LF3,LF3C,NL,NLC
D918	N	4" NW	LF15,LCF15,LF2,LF2C,LF3,LF3C,NL,NLC
D919	N	4" NW	LF15,LCF15,LF2,LF2C,LF3,LF3C,NL,NLC
D919	N	3" LW	LF15,LCF15,LF2,LF2C,LF3,LF3C,NL,NLC
D922	N	4" NW	BL,BLC,LF15,LCF15,LF2,LF2C,LF3,LF3C,NL,NLC
D922	N	3" LW	BL,BLC,LF15,LCF15,LF2,LF2C,LF3,LF3C,NL,NLC
D923	N	4" NW	BL,BLC,LF15,LCF15,LF2,LF2C,LF3,LF3C,NL,NLC
D923	N	3" LW	BL,BLC,LF15,LCF15,LF2,LF2C,LF3,LF3C,NL,NLC
D925	N	4" NW	BL,BLC,LF15,LCF15,LF2,LF2C,LF3,LF3C,NL,NLC
D925	N	3" LW	BL,BLC,LF15,LCF15,LF2,LF2C,LF3,LF3C,NL,NLC
D927	N	4" NW	BL,BLC,LF15,LCF15,LF2,LF2C,LF3,LF3C,NL,NLC
D927	N	3" LW	BL,BLC,LF15,LCF15,LF2,LF2C,LF3,LF3C,NL,NLC
D929	N	4" NW	BL,BLC,LF15,LCF15,LF2,LF2C,LF3,LF3C,NL,NLC
D929	N	3" LW	BL,BLC,LF15,LCF15,LF2,LF2C,LF3,LF3C,NL,NLC
D931	N	4" NW	BL,BLC,LF15,LCF15,LF2,LF2C,LF3,LF3C,NL,NLC
D931	N	3" LW	BL,BLC,LF15,LCF15,LF2,LF2C,LF3,LF3C,NL,NLC

RESTRAINED ASSEMBLY RATINGS (HOURLY)

1 1/2 (continued on page 64)

- Canam is not responsible for the adhesive ability of any spray applied fire resistive material, or for any treatment, cleaning, or preparation of the deck surface required for adhesion of fire resistive material.
- The live loads shown in the composite tables may require a reduction if a U.L. fire rating is required. The worst load reduction for any design is 40%. Designs D742, D825, D840, D860, D902, D907, D914, and D916 do not require a reduction if the sidelaps are welded at 24" o.c. as was used in the fire test.
- Be sure to check the U.L. Fire Resistance Directory for all details of construction.
- Listings marked with * allow the use of phosphatized/painted noncellular deck. See design description for specific product exclusions (for example, LF15 not always allowed). All D3xx and D9xx (except D908) listings allow the use of phosphatized/painted noncellular deck. Phos./Ptd. deck is limited to a 3 hr. rating.

In the F.P. column:
S = suspended ceiling
SFRM = spray applied fire resistive material
N = no fireproofing on the deck.
MFB = mineral & fiberboards.

- The concrete cover is measured from the top of the deck - add the deck depth to get the total slab thickness.
- The BSA approvals for use in New York City are 620-76-SM (2 hours) and 621-76-SM (3 hours).
- Some listings contain more than one concrete cover for LW concrete because they are dependant upon the density of the concrete. Required topping can depend on suspended ceiling type.

Product Codes:
BL = B-LOK
BLC = B-LOK cellular
INV. BL = Inverted B-LOK
LF15 = 1 1/2" LOK floor
LFC15 = 1 1/2" LOK floor cellular
LF2 = 2" LOK floor
LFC2 = 2" LOK floor cellular
LF3 = 3" LOK floor
LFC3 = 3" LOK floor cellular
NL = N-LOK
NLC = N-LOK cellular
INV. NL = Inverted N-LOK
J = J Deck
LS4.5 = 4 1/2" LS Deck

- #10 - 16 x 3/4" long screws may be substituted at side laps when button punching is listed. Substitution is not approved when only welds are listed.

FLOOR DECK

FIRE RATINGS



1. Canam is not responsible for the adhesive ability of any spray applied fire resistive material, or for any treatment, cleaning, or preparation of the deck surface required for adhesion of fire resistive material.

2. The live loads shown in the composite tables may require a reduction if a U.L. fire rating is required. The worst load reduction for any design is 40%. Designs D742, D825, D840, D860, D902, D907, D914, and D916 do not require a reduction if the sidelaps are welded at 24" o.c. as was used in the fire test.

3. Be sure to check the U.L. Fire Resistance Directory for all details of construction.

4. Listings marked with * allow the use of phosphatized/painted noncellular deck. **See design description for specific product exclusions (for example, LF15 not always allowed). All D3xx and D9xx (except D908) listings allow the use of phosphatized/painted noncellular deck. Phos./Ptd. deck is limited to a 3 hr. rating.**

In the F.P. column:

- S** = suspended ceiling
- SFRM** = spray applied fire resistive material
- N** = no fireproofing on the deck.
- MFB** = mineral & fiberboards.

6. The concrete cover is measured from the top of the deck - add the deck depth to get the total slab thickness.

7. The BSA approvals for use in New York City are 620-76-SM (2 hours) and 621-76-SM (3 hours).

8. Some listings contain more than one concrete cover for LW concrete because they are dependant upon the density of the concrete. Required topping can depend on suspended ceiling type.

Product Codes:

- BL** = B-LOK
- BLC** = B-LOK cellular
- INV. BL** = Inverted B-LOK
- LF15** = 1 1/2" LOK floor
- LFC15** = 1 1/2" LOK floor cellular
- LF2** = 2" LOK floor
- LFC2** = 2" LOK floor cellular
- LF3** = 3" LOK floor
- LFC3** = 3" LOK floor cellular
- NL** = N-LOK
- NLC** = N-LOK cellular
- INV. NL** = Inverted N-LOK
- J** = J Deck
- LS4.5** = 4 1/2" LS Deck

10. #10 - 16 x 3/4" long screws may be substituted at side laps when button punching is listed. Substitution is not approved when only welds are listed.

U.L. Design No	F.P.	Concrete Cover and Type	Canam Product
1	1 1/2	D940 N 3" LW	BL,BLC,LF15,LFC15,LF2,LFC2,LF3,LFC3,NL,NLC,J,LS4.5
		D940 N 4" NW	BL,BLC,LF15,LFC15,LF2,LFC2,LF3,LFC3,NL,NLC,J,LS4.5
		D943 N 4" NW	BL,BLC,LF15,LFC15,LF2,LFC2,LF3,LFC3,NL,NLC
		D943 N 3" LW	BL,BLC,LF15,LFC15,LF2,LFC2,LF3,LFC3,NL,NLC
		D949 N 4" NW	BL,BLC,LF15,LFC15,LF2,LFC2,LF3,LFC3,NL,NLC
		D949 N 3" LW	BL,BLC,LF15,LFC15,LF2,LFC2,LF3,LFC3,NL,NLC
		D215 S 2 1/2" NW	BL, BLC
		D216 S 2 1/2" NW,LW	BL,BLC,LF2,LF2C,LF3,LFC3,NL,NLC
		D218 S 2 1/2" NW	BL, BLC
		D219 S 2 1/2" NW,LW	BL,BLC,LF2,LF2C,LF3,LFC3,NL,NLC
		D303 MFB 4 1/2" NW	BL,BLC,LF15,LFC15,LF2,LFC2,LF3,LFC3,NL,NLC
		D303 MFB 3 1/2" LW	BL,BLC,LF15,LFC15,LF2,LFC2,LF3,LFC3,NL,NLC
		D502 S 2 1/2" NW	BL,BLC,LF2,LF2C,LF3,LFC3,NL,NLC
		D503 S 2 1/2" NW	LF2, LF3, NL
		D703 SFRM 2 1/2" NW,LW	BL,BLC,LF15,LFC15,LF2,LFC2,LF3,LFC3,NL,NLC*
		D704 SFRM 2 1/2" NW	BL,BLC,LF15,LFC15
		D706 SFRM 2 1/2" NW,LW	LF3,LFC3
		D712 SFRM 2 1/2" NW,LW	BL,BLC,LF15,LFC15,LF2,LFC2,LF3,LFC3,NL,NLC*
		D716 SFRM 2 1/2" NW,LW	BL,BLC,LF15,LFC15,LF2,LFC2,LF3,LFC3*
		D722 SFRM 2 1/2" NW,LW	BL,BLC,LF15,LFC15,LF2,LFC2,LF3,LFC3,NL,NLC*
		D726 SFRM 2 1/2" NW,LW	LF15,LF2,LF3,NL*
		D727 SFRM 2 1/2" NW	INV.BL,INV.NL
		D730 SFRM 2 1/2" NW	LF2,LFC2,LF3,LFC3,NL,NLC*
		D739 SFRM 2 1/2" NW,LW	BL,BLC,LF15,LFC15,LF2,LFC2,LF3,LFC3,NL,NLC*
		D742 SFRM 2 1/2" NW	LF15,LF2,LF3,NL*
		D743 SFRM 2" NW,LW	LF2,LF3*
		D745 SFRM 2 1/2" NW,LW	LF2,LF3*
		D746 SFRM 2 1/2" LW	BL*
		D747 SFRM 2 1/2" LW	LF2*
		D750 SFRM 2 1/2" NW,LW	BL,INV.BL,LF2,LF3,NL*
		D752 SFRM 2 1/2" LW	BL,BLC,LF2,LFC2,LF3,LFC3*
		D755 SFRM 2 1/2" NW,LW	BL,BLC,LF15,LFC15,LF2,LFC2,LF3,LFC3,NL,NLC*
		D759 SFRM 2 1/2" NW,LW	BL,BLC,LF15,LFC15,LF2,LFC2,LF3,LFC3,NL,NLC*
		D760 SFRM 2 1/2" NW,LW	BL,LF15,LF2,LF3,NL*
		D764 SFRM 2 1/2" NW,LW	BL,BLC,LF15,LFC15,LF2,LFC2,LF3,LFC3,NL,NLC*
		D767 SFRM 2 1/2" NW,LW	BL,BLC,LF15,LFC15,LF2,LFC2,LF3,LFC3,NL,NLC*
		D769 SFRM 2 1/2" NW	INV.BL,INV.NL
		D771 SFRM 2 1/2" NW	LF15,LF2,LF3,NL*
		D772 SFRM 2 1/2" NW,LW	LF2,LF3*
		D773 SFRM 2 1/2" LW	BL*
D774 SFRM 2 1/2" LW	LF2*		
D775 SFRM 2 1/2" NW,LW	BL,INV.BL,LF2,LF3,NL*		
D778 SFRM 2 1/2" LW	LF2,LFC2,LF3,LFC3		
D778 SFRM 3" NW	LF2,LFC2,LF3,LFC3		
D779 SFRM 2 1/2" NW,LW	BL,LF15,LF2,LF3*		
D782 SFRM 3 1/4" LW	LF15,LF2,LF3,NL*		
D787 SFRM 2 1/2" NW,LW	BL,BLC,LF15,LFC15,LF2,LFC2,LF3,LFC3,NL,NLC*		
D788 SFRM 2 1/2" NW,LW	BL,BLC,LF15,LFC15,LF2,LFC2,LF3,LFC3,NL,NLC		
D822 SFRM 2 1/2" NW,LW	LF2,LFC2,LF3,LFC3,NL,NLC*		
D824 SFRM 2 1/2" NW,LW	BL,BLC,LF15,LFC15		
D825 SFRM 2 1/2" NW,LW	BL,BLC,LF15,LFC15,LF2,LFC2,LF3,LFC3,NL,NLC*		
D826 N 3 1/4" LW	BL,BLC,LF15,LFC15,LF2,LFC2,LF3,LFC3,NL,NLC*		
D831 SFRM 2 1/2" NW,LW	BL,BLC,LF15,LFC15,LF2,LFC2,LF3,LFC3,NL,NLC*		
D832 SFRM 2 1/2" NW,LW	BL,BLC,LF15,LFC15,LF2,LFC2,LF3,LFC3,NL,NLC*		
D833 SFRM 2 1/2" NW,LW	BL,BLC,LF15,LFC15,LF2,LFC2,LF3,LFC3*		
D837 SFRM 2 1/2" NW	BL,BLC,LF15,LFC15*		
D840 N 3 1/4" LW	BL,BLC,LF15,LFC15,LF2,LFC2,LF3,LFC3,NL,NLC*		
D840 N 3 1/2" LW	BL,BLC,LF15,LFC15,LF2,LFC2,LF3,LFC3,NL,NLC*		
D847 SFRM 2 1/2" NW,LW	LF2,LFC2,LF3,LFC3,NL,NLC*		
D852 SFRM 2 1/2" NW,LW	BL,BLC,LF15,LFC15,LF2,LFC2,LF3,LFC3*		
D858 SFRM 2 1/2" NW,LW	LF2,LFC2,LF3,LFC3*		
D859 SFRM 2" NW,LW	LF2,LFC2,LF3,LFC3*		
D860 SFRM 3 1/4" LW	LF15,LFC15,LF2,LFC2,LF3,LFC3,NL,NLC*		
D861 SFRM 2 1/2" NW,LW	LF2,LF3*		
D862 SFRM 2 1/2" LW	LF2,LF3*		
D902 N 4 1/2" NW	BL,BLC,LF15,LFC15,LF2,LFC2,LF3,LFC3,NL,NLC		
D902 N 3 1/4" LW	BL,BLC,LF15,LFC15,LF2,LFC2,LF3,LFC3,NL,NLC		
D902 N 3 1/2" LW	BL,BLC,LF15,LFC15,LF2,LFC2,LF3,LFC3,NL,NLC		
D906 N 3 1/4" LW	NLC		
D907 N 3 1/4" LW	BL,BLC,LF15,LFC15,LF2,LFC2,LF3,LFC3		
D908 N 3 1/4" LW	BL,BLC,LF15,LFC15,LF2,LFC2,LF3,LFC3,NL,NLC*		
D913 N 3 1/4" LW	BL,LF15,LF2,LFC2,LF3,LFC3		
D915 N 3 1/4" LW	LF3,LFC3,NL,NLC		
D916 N 4 1/2" NW	BL,BLC,LF15,LFC15,LF2,LFC2,LF3,LFC3,NL,NLC		
D916 N 3 1/4" LW	LF2,LFC2,LF3,LFC3,NL,NLC		
D916 N 3 1/2" LW	BL,BLC,LF15,LFC15,LF2,LFC2,LF3,LFC3,NL,NLC		
D918 N 4 1/2" NW	LF15,LFC15,LF2,LFC2,LF3,LFC3,NL,NLC		
D918 N 3 1/4" LW	LF15,LFC15,LF2,LFC2,LF3,LFC3,NL,NLC		
D918 N 3 1/2" LW	LF15,LFC15,LF2,LFC2,LF3,LFC3,NL,NLC		
D919 N 4 1/2" NW	LF1.5, LFC15, LF2, LFC2, LF3, LFC3, NL, NLC		
D919 N 3 1/4" LW	LF15,LFC15,LF2,LFC2,LF3,LFC3,NL,NLC		
D919 N 3 1/2" LW	LF15,LFC15,LF2,LFC2,LF3,LFC3,NL,NLC		
D920 N 3 1/4" LW	LF2,LFC2,LF3,LFC3		
D922 N 4 1/2" NW	BL,BLC,LF15,LFC15,LF2,LFC2,LF3,LFC3,NL,NLC		
D922 N 3 1/4" LW	LF2,LFC2,LF3,LFC3,NL,NLC		
D922 N 3 1/2" LW	BL,BLC,LF15,LFC15,LF2,LFC2,LF3,LFC3,NL,NLC		
D923 N 4 1/2" NW	BL,BLC,LF15,LFC15,LF2,LFC2,LF3,LFC3,NL,NLC		
D923 N 3 1/4" LW	BL,BLC,LF15,LFC15,LF2,LFC2,LF3,LFC3,NL,NLC		
D923 N 3 1/2" LW	BL,BLC,LF15,LFC15,LF2,LFC2,LF3,LFC3,NL,NLC		
D925 N 4 1/2" NW	BL,BLC,LF15,LFC15,LF2,LFC2,LF3,LFC3,NL,NLC		
D925 N 3 1/4" LW	BL,BLC,LF15,LFC15,LF2,LFC2,LF3,LFC3,NL,NLC		
D925 N 3 1/2" LW	BL,BLC,LF15,LFC15,LF2,LFC2,LF3,LFC3,NL,NLC		
D927 N 4 1/2" NW	BL,BLC,LF15,LFC15,LF2,LFC2,LF3,LFC3,NL,NLC		
D927 N 3 1/4" LW	BL,BLC,LF15,LFC15,LF2,LFC2,LF3,LFC3,NL,NLC		
D927 N 3 1/2" LW	BL,BLC,LF15,LFC15,LF2,LFC2,LF3,LFC3,NL,NLC		
D929 N 4 1/2" NW	BL,BLC,LF15,LFC15,LF2,LFC2,LF3,LFC3,NL,NLC		
D929 N 3 1/4" LW	BL,BLC,LF15,LFC15,LF2,LFC2,LF3,LFC3,NL,NLC		
D929 N 3 1/2" LW	BL,BLC,LF15,LFC15,LF2,LFC2,LF3,LFC3,NL,NLC		
D931 N 4 1/2" NW	BL,BLC,LF15,LFC15,LF2,LFC2,LF3,LFC3,NL,NLC		

RESTRAINED ASSEMBLY RATINGS (HOURLY)
2 (continued on page 65)

FIRE RATINGS

	U.L Design No	F.P.	Concrete Cover and Type	Canam Product
2	D931	N	3 1/4" LW	BL,BLC,LF15,LFC15,LF2,LFC2,LF3,LFC3,NL,NLC
	D931	N	3 1/2" LW	BL,BLC,LF15,LFC15,LF2,LFC2,LF3,LFC3,NL,NLC
	D940	N	4 1/2" NW	BL,BLC,LF1.5,LFC1.5,LF2,LFC2,LF3,LFC3,NL,NLC,J,LS4.5
	D940	N	3 1/4" LW	BL,BLC,LF1.5,LFC1.5,LF2,LFC2,LF3,LFC3,NL,NLC,J,LS4.5
	D943	N	4 1/2" NW	BL,BLC,LF15,LFC15,LF2,LFC2,LF3,LFC3,NL,NLC
	D943	N	3 1/4" LW	BL,BLC,LF15,LFC15,LF2,LFC2,LF3,LFC3,NL,NLC
	D943	N	3 1/2" LW	BL,BLC,LF15,LFC15,LF2,LFC2,LF3,LFC3,NL,NLC
	D949	N	4 1/2" NW	BL,BLC,LF15,LFC15,LF2,LFC2,LF3,LFC3,NL,NLC
	D949	N	3 1/4" LW	BL,BLC,LF15,LFC15,LF2,LFC2,LF3,LFC3,NL,NLC
	D949	N	3 1/2" LW	BL,BLC,LF15,LFC15,LF2,LFC2,LF3,LFC3,NL,NLC
	D216	S	3 1/2" NW,LW	BL,BLC,LF2,LFC2,LF3,LFC3,NL,NLC
	D218	S	3 1/4" NW	BL,BLC
	D219	S	3 1/2" NW,LW	BL,BLC,LF2,LFC2,LF3,LFC3,NL,NLC
	D701	SFRM	2 1/2" NW	BL,BLC,LF15,LFC15,LF3,LFC3
	D703	SFRM	2 1/2" NW,LW	BL,BLC,LF15,LFC15,LF2,LFC2,LF3,LFC3,NL,NLC*
	D708	SFRM	2 1/2" NW,LW	BL,BLC,LF15,LFC15,LF2,LFC2,LF3,LFC3*
	D709	SFRM	2 1/2" NW,LW	LF3,LFC3
	D715	SFRM	2 1/2" NW,LW	LF2,LF3,NL*
D739	SFRM	2 1/2" NW,LW	BL,BLC,LF15,LFC15,LF2,LFC2,LF3,LFC3,NL,NLC*	
D742	SFRM	3 1/2" NW	LF15,LF2,LF3, NL*	
D743	SFRM	2" NW,LW	LF2,LF3*	
D746	SFRM	2 1/2" LW	BL*	
D754	SFRM	3 1/4" LW	LF15,LF2,LF3,NL*	
D755	SFRM	2 1/2" NW,LW	BL,BLC,LF15,LFC15,LF2,LFC2,LF3,LFC3,NL,NLC*	
D759	SFRM	2 1/2" NW,LW	BL,BLC,LF15,LFC15,LF2,LFC2,LF3,LFC3,NL,NLC*	
D760	SFRM	2 1/2" NW,LW	BL,LF15,LF2,LF3,NL*	
D767	SFRM	2 1/2" NW,LW	BL,BLC,LF15,LFC15,LF2,LFC2,LF3,LFC3,NL,NLC*	
D768	SFRM	2 1/2" NW,LW	BL,BLC,LF15,LFC15,LF2,LFC2,LF3,LFC3*	
D771	SFRM	3 1/2" NW	LF15,LF2,LF3,NL*	
D773	SFRM	2 1/2" LW	BL*	
D777	SFRM	3 1/4" LW	LF15,LF2,LF3,NL*	
D779	SFRM	2 1/2" NW,LW	BL,LF15,LF2,LF3*	
D782	SFRM	3 1/4" LW	LF15,LF2,LF3,NL*	
D787	SFRM	2 1/2" NW,LW	BL,BLC,LF15,LFC15,LF2,LFC2,LF3,LFC3,NL,NLC*	
D788	SFRM	2 1/2" NW,LW	BL,BLC,LF15,LFC15,LF2,LFC2,LF3,LFC3,NL,NLC	
D814	SFRM	2 1/2" NW,LW	BL,BLC,LF15,LFC15,LF3,LFC3*	
D816	SFRM	2 1/2" NW,LW	BL,BLC,LF15,LFC15,LF2,LFC2,LF3,LFC3,NL,NLC*	
D831	SFRM	2 1/2" NW,LW	BL,BLC,LF15,LFC15,LF2,LFC2,LF3,LFC3,NL,NLC*	
D832	SFRM	2 1/2" NW,LW	BL,BLC,LF15,LFC15,LF2,LFC2,LF3,LFC3,NL,NLC*	
D833	SFRM	2 1/2" NW,LW	BL,BLC,LF15,LFC15,LF2,LFC2,LF3,LFC3*	
D838	SFRM	2 1/2" NW,LW	BL,BLC,LF15,LFC15,LF2,LFC2,LF3,LFC3	
D849	SFRM	2 1/2" NW	LF3,LFC3,NL,NLC	
D858	SFRM	2 1/2" NW,LW	LF2,LFC2,LF3,LFC3*	
D859	SFRM	2" NW,LW	LF2,LFC2,LF3,LFC3*	
D860	SFRM	3 1/4" LW	LF15,LFC15,LF2,LFC2,LF3,LFC3,NL,NLC*	
D867	SFRM	2 1/2" NW,LW	BL,BLC,LF15,LFC15,LF2,LFC2,LF3,LFC3	
D902	N	5 1/4" NW	BL,BLC,LF15,LFC15,LF2,LFC2,LF3,LFC3,NL,NLC	
D902	N	4 3/16" LW	BL,BLC,LF15,LFC15,LF2,LFC2,LF3,LFC3,NL,NLC	
D902	N	4 7/16" LW	BL,BLC,LF15,LFC15,LF2,LFC2,LF3,LFC3,NL,NLC	
D916	N	5 1/4" NW	BL,BLC,LF15,LFC15,LF2,LFC2,LF3,LFC3,NL,NLC	
D916	N	4 3/16" LW	BL,BLC,LF15,LFC15,LF2,LFC2,LF3,LFC3,NL,NLC	
D916	N	4 7/16" LW	BL,BLC,LF15,LFC15,LF2,LFC2,LF3,LFC3,NL,NLC	
D918	N	5 1/4" NW	LF15,LFC15,LF2,LFC2,LF3,LFC3,NL,NLC	
D918	N	4 3/16" LW	LF15,LFC15,LF2,LFC2,LF3,LFC3,NL,NLC	
D918	N	4 7/16" LW	LF15,LFC15,LF2,LFC2,LF3,LFC3,NL,NLC	
D919	N	5 1/4" NW	LF15,LFC15,LF2,LFC2,LF3,LFC3,NL,NLC	
D919	N	4 3/16" LW	LF15,LFC15,LF2,LFC2,LF3,LFC3,NL,NLC	
D919	N	4 7/16" LW	LF15,LFC15,LF2,LFC2,LF3,LFC3,NL,NLC	
D922	N	5 1/4" NW	BL,BLC,LF15,LFC15,LF2,LFC2,LF3,LFC3,NL,NLC	
D922	N	4 3/16" LW	BL,BLC,LF15,LFC15,LF2,LFC2,LF3,LFC3,NL,NLC	
D922	N	4 7/16" LW	BL,BLC,LF15,LFC15,LF2,LFC2,LF3,LFC3,NL,NLC	
D923	N	5 1/4" NW	BL,BLC,LF15,LFC15,LF2,LFC2,LF3,LFC3,NL,NLC	
D923	N	4 3/16" LW	BL,BLC,LF15,LFC15,LF2,LFC2,LF3,LFC3,NL,NLC	
D923	N	4 7/16" LW	BL,BLC,LF15,LFC15,LF2,LFC2,LF3,LFC3,NL,NLC	
D925	N	5 1/4" NW	BL,BLC,LF15,LFC15,LF2,LFC2,LF3,LFC3,NL,NLC	
D925	N	4 3/16" LW	BL,BLC,LF15,LFC15,LF2,LFC2,LF3,LFC3,NL,NLC	
D925	N	4 7/16" LW	BL,BLC,LF15,LFC15,LF2,LFC2,LF3,LFC3,NL,NLC	
D927	N	5 1/4" NW	BL,BLC,LF15,LFC15,LF2,LFC2,LF3,LFC3,NL,NLC	
D927	N	4 3/16" LW	BL,BLC,LF15,LFC15,LF2,LFC2,LF3,LFC3,NL,NLC	
D927	N	4 7/16" LW	BL,BLC,LF15,LFC15,LF2,LFC2,LF3,LFC3,NL,NLC	
D929	N	5 1/4" NW	BL,BLC,LF15,LFC15,LF2,LFC2,LF3,LFC3,NL,NLC	
D929	N	4 3/16" LW	BL,BLC,LF15,LFC15,LF2,LFC2,LF3,LFC3,NL,NLC	
D929	N	4 7/16" LW	BL,BLC,LF15,LFC15,LF2,LFC2,LF3,LFC3,NL,NLC	
D931	N	5 1/4" NW	BL,BLC,LF15,LFC15,LF2,LFC2,LF3,LFC3,NL,NLC	
D931	N	4 3/16" LW	BL,BLC,LF15,LFC15,LF2,LFC2,LF3,LFC3,NL,NLC	
D931	N	4 7/16" LW	BL,BLC,LF15,LFC15,LF2,LFC2,LF3,LFC3,NL,NLC	
D943	N	5 1/4" NW	BL,BLC,LF15,LFC15,LF2,LFC2,LF3,LFC3,NL,NLC	
D943	N	4 3/16" LW	BL,BLC,LF15,LFC15,LF2,LFC2,LF3,LFC3,NL,NLC	
D943	N	4 7/16" LW	BL,BLC,LF15,LFC15,LF2,LFC2,LF3,LFC3,NL,NLC	
D949	N	5 1/4" NW	BL,BLC,LF15,LFC15,LF2,LFC2,LF3,LFC3,NL,NLC	
D949	N	4 3/16" LW	BL,BLC,LF15,LFC15,LF2,LFC2,LF3,LFC3,NL,NLC	
D949	N	4 7/16" LW	BL,BLC,LF15,LFC15,LF2,LFC2,LF3,LFC3,NL,NLC	
D739	SFRM	2 1/2" NW,LW	BL,BLC,LF15,LFC15,LF2,LFC2,LF3,LFC3,NL,NLC	
D754	SFRM	3 1/4" LW	LF15,LF2,LF3,NL	
D760	SFRM	2 1/2" NW,LW	BL,LF15,LF2,LF3,NL	
D767	SFRM	2 1/2" NW,LW	BL,BLC,LF15,LFC15,LF2,LFC2,LF3,LFC3,NL,NLC	
D777	SFRM	3 1/4" LW	LF15,LF2,LF3,NL	
D779	SFRM	2 1/2" NW,LW	BL,LF15,LF2,LF3	
D782	SFRM	3 1/4" LW	LF15,LF2,LF3,NL	
D787	SFRM	2 1/2" NW,LW	BL,BLC,LF15,LFC15,LF2,LFC2,LF3,LFC3,NL,NLC	
D788	SFRM	2 1/2" NW, LW	BL,BLC,LF15,LFC15,LF2,LFC2,LF3,LFC3,NL,NLC	
D858	SFRM	2 1/2" NW,LW	LF2,LFC2,LF3,LFC3	
D860	SFRM	3 1/4" LW	LF15,LFC15,LF2,LFC2,LF3,LFC3,NL,NLC	

The following information is taken from the Steel Deck Institute publication "Composite Deck Design Handbook," 1997 edition:

"In the Underwriter Fire Resistance Directory the composite deck constructions show hourly ratings for restrained and unrestrained assemblies. ASTM E119 provides information in appendix X3 called "Guide for Determining Conditions of Restraint for Floor and Roof Assemblies and for Individual Beams". After a careful review of this guide the Steel Deck Institute determined that all interior and exterior spans of multispan deck properly attached to steel framing are restrained. Additionally, all multiple span composite deck slabs attached to bearing walls are restrained. In fact, there is almost no realistic condition in which a composite deck-slab could not be considered to be restrained - perhaps a single span deck system which is unattached to framing or a wall in order to provide a removable slab."

FIRE RATINGS

ANSI/SDI-C1.0 Standard for Composite Steel Floor Deck

1. General

1.1 Scope:

- A. This specification for Composite Steel Deck shall govern the materials, design, and erection of cold formed steel deck which acts as a permanent form and as positive reinforcement for a structural concrete slab.
- B. Commentary shall not be considered part of the mandatory document.

1.2 Reference Codes, Standards and Documents:

- A. Codes and Standards:
For purposes of this Standard, comply with applicable provisions of the following Codes and Standards:
1. American Iron and Steel Institute (AISI) Standard-North American Specification for the Design of Cold-Formed Steel Structural Members, 2001 Edition with Supplement 2004
 2. American Welding Society-ANSI/AWS D1.3 Structural Welding Code/Sheet Steel-98 Structural Welding Code-Sheet Steel
 3. American Society for Testing and Materials (ASTM) A653 (A653M)-06, A924 (A924M)-06, A1008 (A1008M)-06, A820 (A820M)-06, C1399 (C1399M)-04, Test Method E2322-03, ASTM Subcommittee CO9.42
 4. American Concrete Institute (ACI) Building Code Requirements for Reinforced Concrete – ACI 318-05
 5. American Society of Civil Engineering (ASCE)-SEI/ASCE7-05
 6. American Institute of Steel Construction (AISC)-Specification for Structural Steel Buildings, 13th Edition

7. Underwriters Laboratories (UL) Fire Resistance Directory-
<http://www.ul.com/database> 2006

Commentary: Many fire related assemblies that use composite floor decks are available. In the Underwriters Laboratories *Fire Resistance Directory*, the composite deck constructions show hourly ratings for restrained and unrestrained assemblies. ASTM E119 provides information in appendix X3 called "Guide for Determining Conditions of Restraint for Floor and Roof Assemblies and for Individual Beams".

- B. Reference Documents:
Refer to the following documents:

1. SDI Composite Deck Design Handbook-CDD2-1997
2. SDI Manual of Construction with Steel Deck-MOC2-2006
3. SDI Standard Practice Details-SPD2-2001
4. SDI Diaphragm Design Manual-DDMO3-2004

2. Products

2.1 Material:

- A. Sheet steel for galvanized deck shall conform to ASTM A653 (A653M) Structural Quality, with a minimum yield strength of 33 ksi (230 MPa).
- B. Sheet steel for uncoated or phosphatized top/painted bottom deck shall conform to ASTM A1008 (A1008M) with a minimum yield strength of 33 ksi (230 MPa). Other structural sheet steels or high strength low alloy steels are acceptable, and shall be selected from the *North American Specification for the Design of Cold-Formed Steel Structural Members*.

- C. Sheet steel for accessories shall conform to ASTM A653 (A653M)-minimum yield strength of 33 ksi (230 MPa). Structural Quality for structural accessories, ASTM A653 (A653M) Commercial Quality for non-structural accessories, or ASTM A1008 (A1008M) for either structural or non-structural accessories. Other structural sheet steels or high strength low alloy steels are acceptable, and shall be selected from the *North American Specification for the Design of Cold-Formed Steel Structural Members*.

- D. The deck type (profile) and thickness (gage) shall be as shown on the plans.

Commentary: Most composite steel floor deck is manufactured from steel conforming to ASTM Designation A1008 (A1008M), Grades 33 and 40, or from A653 (A653M), Structural Sheet Steel. When specifying alternative steels, certain restrictions apply (See *North American Specification for the Design of Cold-Formed Steel Structural Members* Section A 2-3.2). 2.1A refers to the use of galvanized deck while 2.1B refers to the use of uncoated or phosphatized top/painted underside deck. In most cases the designer will choose one finish or the other. However, both types of finish may be used on a job, in which case the designer must indicate on the plans and project specifications the areas in which each is used. (Refer to Section 2.3 and the commentary of these specifications). In section 2.1D, the deck type is the particular profile of deck chosen by the designer.

2.2 Tolerance:

- A. Uncoated thickness shall not be less than 95% of the design thickness as listed in Table 2.2.1:

ANSI/SDI-C1.0 Standard for Composite Steel Floor Deck

Table 2.2.1

Gage No.	Design Thickness		Minimum Thickness	
	in.	mm.	in.	mm.
22	0.0295	0.75	0.028	0.71
21	0.0329	0.84	0.031	0.79
20	0.0358	0.91	0.034	0.86
19	0.0418	1.06	0.040	1.01
18	0.0474	1.20	0.045	1.14
17	0.0538	1.37	0.051	1.30
16	0.0598	1.52	0.057	1.44

- B. Panel length shall be within plus or minus 1/2 inch (12 mm) of specified length.
- C. Panel cover width shall be no greater than minus 3/8 inch (10 mm), plus 3/4 inch (20 mm).
- D. Panel camber and/or sweep shall be no greater than 1/4 inch in 10 foot length (6 mm in 3 m).
- E. Panel end out of square shall not be greater than 1/8 inch per foot of panel width (10 mm per m).

2.3 Finish:

- A. Galvanizing shall conform to ASTM A653 (A653M).
- B. Uncoated or phosphatized topside with painted underside shall be applied to steel sheet conforming to ASTM A1008 (A1008M).
- C. The finish on the steel composite deck shall be suitable for the environment of the structure.

Commentary: The finish on the steel composite deck shall be as specified by the designer and be suitable for the environment of the structure. Since the composite deck is the positive bending reinforcement for the slab, it must be designed to last the life of the structure. A galvanized finish equal to ASTM A653 (A653M)-G30 minimum is recommended. When composite deck with a phosphatized top and painted bottom is used, the primer coat is intended to protect the steel for only a short period of exposure in ordinary atmospheric conditions and shall be

considered an impermanent and provisional coating.

2.4 Design:

A. Deck as a form

1. The section properties for the steel floor deck unit (as a form in bending) shall be computed in accordance with the *North American Specification for the Design of Cold-Formed Steel Structural Members*.
2. Allowable Stress Design (ASD): Bending stress shall not exceed 0.60 times the yield strength, nor exceed 36 ksi (250MPa) under the combined loads of wet concrete, deck weight, and the following construction live loads: 20 pounds per square foot (1 kPa) uniform load or 150 pound concentrated load on a 1'-0" (300 mm) wide section of deck (2.2 kN per m). The interaction of shear and bending shall be considered in the calculations. (See Figure 1-Attachment C1)
3. Load and Resistance Factor Design (LRFD): The load combinations for construction are as shown in Attachment C1. Load factors shall be in accordance with ASCE 7 (See Section 1.2.A.5). The resistance factors and nominal resistances shall be in accordance with *North American Specification for the Design of Cold-Formed Steel Structural Members*.

Commentary: The loading shown in Figure 1 of Attachment C1 is representative of the sequential loading of wet concrete on the deck. The 150 pound load (per foot of width) is the result of distributing a 300 pound (1.33 kN) man over a 2 foot (600 mm) width. Experience has shown this to be a conservative distribution. The metric equivalent of the 150 pound load is 2.2 kN per meter of width. For single span deck conditions, the ability to control the concrete placement

may be restricted and an amplification factor of 1.5 is applied to the concrete load to address this condition; however, in order to keep this 50% load increase within a reasonable limit, the increase is not to exceed 30 psf (1.44 kPa). In LRFD, a load factor for construction of 1.4 is applied to this load. Whenever possible, the deck shall be multi-span and not require shoring during concrete placement.

4. Deck Deflection: Calculated deflections of the deck, as a form, shall be based on the load of the wet concrete as determined by the design slab thickness and the weight of the steel deck, uniformly loaded on all spans, and shall be limited to 1/180 of the clear span or 3/4 inch (20 mm), whichever is smaller. Calculated deflections shall be relative to supporting members.

Commentary: The deflection calculations do not take into account construction loads because these are considered temporary loads. The deck is designed to always be in the elastic range so removal of temporary loads should allow the deck to recover. The structural steel also deflects under the loading of the wet concrete.

The designer is urged to check the deflection of the total system, especially if composite beams and girders are being used. If the designer wants to include additional concrete loading on the deck because of frame deflection, the additional load should be shown on the design drawings or stated in the deck section of the job specifications.

5. Minimum Bearing: Minimum interior bearing lengths shall be determined in accordance with the web crippling provisions of the *North American Specification for the Design of Cold-Formed Steel Structural Members*; a uniform

loading case of wet concrete, plus the weight of the steel deck, plus 20 psf (1 kPa) construction load shall be used. (See Figure 3-Attachment C1)

Commentary: Experience has shown that 1-1/2 inches (38 mm) of bearing is sufficient for composite floor decks. If less than 1-1/2 inches (38 mm) of end bearing is available, or if high support reactions are expected, the design professional should check the deck web crippling capacity. The deck must be adequately attached to the structure to prevent slip off.

6. Diaphragm Shear Capacity: Diaphragms without concrete shall be designed in accordance with the *SDI Diaphragm Design Manual*, or from tests conducted by an independent professional engineer.

Commentary: Calculations of diaphragm strength and stiffness should be made using the *SDI Diaphragm Design Manual*. If testing is used as the means for determining the diaphragm strength and stiffness, then it should follow the AISI TS 7-02 test protocol.

B. Deck and Concrete as a Composite Slab:

1. General: The "SDI Method" (refer to *SDI Composite Deck Design Handbook*) shall be limited to galvanized or topside uncoated steel decks with embossments. The embossment patterns shall be typical of the manufactured steel deck with the depth of the embossment not less than 90% of the tested embossment depth. (Refer to Attachment C4 for further limitations).

The composite slab shall be designed as a reinforced concrete slab with the steel deck acting as the positive

reinforcement. The deck must be suitable to develop composite interaction. Justification of this requires full scale testing as per ASTM E2322, or calculations based upon testing.

- a. Allowable Strength Design (ASD) shall be permitted as an alternate design method. (See *SDI Composite Deck Design Handbook*.)
- b. Standard reinforced concrete design procedures shall be used to determine ultimate load capacity. The allowable superimposed load shall then be determined by deducting the weight of the slab and the deck. Attachment C4, *Strength and Serviceability Determination of Composite Deck Slab* shall be used for strength determination.

Commentary: High concentrated loads, diaphragm loads, etc. require additional analysis. Horizontal load capacities can be determined by referring to the *SDI Diaphragm Design Manual*. Concentrated loads can be analyzed by the methods shown in the *SDI Composite Deck Design Handbook*. Most published live load tables are based on simple span analysis of the composite system; that is, the slab is assumed to crack over each support.

2. Load Determination: Using standard reinforced concrete design procedures, the allowable superimposed load shall be found by using appropriate load and resistance design factors (LRFD) and applicable reduction factors based on the presence, absence, or spacing of shear studs on beams perpendicular to the deck. (Refer to Attachment C4 and C5)

Commentary: By using the reference analysis techniques or test results, the deck manufacturer determines the live loads that can be applied to the composite deck slab combination. The results are usually published as uniform load tables. For most applications, the deck thickness and profile is selected so that shoring is not required; the live load capacity of the composite system is usually more than adequate for the superimposed live loads. In calculating the section properties of the deck, the AISI provisions may require that compression zones in the deck be reduced to an "effective width," but as tensile reinforcement, the total area of the cross section may be used. (See attachment C5)

Coatings other than those tested may be investigated, and if there is evidence that their performance is better than that of the tested product, additional testing may not be required.

3. Concrete: Concrete design shall be in accordance with the *ACI Building Code Requirements for Reinforced Concrete*. Minimum compressive strength (f'_c) shall be a minimum of 3 ksi (20 MPa) or as required for fire ratings or durability. Admixtures containing chloride salts shall not be used.

Commentary: Load tables are generally calculated by using a concrete strength of 3 ksi (20 MPa). Composite slab capacities are not greatly affected by variations in concrete compressive strength; but, if the strength falls below 3 ksi (20 MPa) it would be advisable to check shear stud strengths. Fire rating requirements may dictate the minimum concrete strength. The use of admixtures containing chloride salts is not allowed because the salts will corrode the steel deck.

ANSI/SDI-C1.0 Standard for Composite Steel Floor Deck

a. Minimum Cover: The minimum concrete thickness above the top of the steel deck shall be 2 inches (50 mm). When additional (negative bending) reinforcement is placed in the slab, the minimum cover of concrete above the reinforcing shall be in accordance with the *ACI Building Code Requirements for Reinforced Concrete*.

4. Deflection: Deflection of the composite slab shall not exceed 1/360 of the clear span under the superimposed live load.

Commentary: Live load deflections are seldom a design factor. The deflection of the slab/deck combination can be predicted by using the average of the cracked and uncracked moments of inertia as determined by the transformed section method of analysis. Refer to Attachment C5 of this specification or the *SDI Composite Deck Design Handbook*.

5. Suspended Loads: All suspended loads must be included in the analysis and calculations for strength and deflection.

Commentary: The designer must take into account the sequence of loading. Suspended loads may include ceilings, light fixtures, ducts or other utilities. The designer must be informed of any loads applied after the composite slab has been installed.

Care should be used during the placement of loads on all types of hanger tabs or other hanging devices for the support of ceilings so that an approximate uniform loading is maintained. The individual manufacturer should be consulted for allowable loading on single hanger tabs. Improper use of hanger tabs or other hanging devices could result in the overstressing of tabs and/or the overloading of the composite deck slab.

6. Reinforcement:
a. Temperature and shrinkage reinforcement, consisting of welded wire fabric or reinforcing bars, shall have a minimum area of 0.00075 times the area of the concrete above the deck (per foot or meter of width), but shall not be less than the area provided by 6x6-W1.4 x W1.4 welded wire fabric.

Fibers shall be permitted as a suitable alternative to the welded wire fabric specified for temperature and shrinkage reinforcement. Cold-drawn steel fibers meeting the criteria of ASTM A820, at a minimum addition rate of 25 lb/cu yd (14.8 kg/cu meter), or macro synthetic fibers "Coarse fibers" (per ASTM Subcommittee CO9.42), made from virgin polyolefin, shall have an equivalent diameter between 0.4 mm (0.016 in.) and 1.25 mm (0.05 in.), having a minimum aspect ratio (length/equivalent diameter) of 50, at a minimum addition rate of 4 lb./cu yd (2.4 kg/m³) are suitable to be used as minimum temperature and shrinkage reinforcement.

Commentary: Neither welded wire fabric or fibers will prevent cracking; however, they have been shown to do a good job of crack control. The welded wire fabric must be placed near the top of the slab [3/4 to 1 inch cover (20 to 25 mm)] at supports and draped toward the center of the deck span. If a welded wire fabric is used with a steel area given by the above formula, it will not be sufficient as the total negative reinforcement. If the minimum quantity of steel fibers, or macro synthetic fibers, are used for shrinkage and temperature reinforcement, they will not be sufficient as a total negative reinforcement.

b. Negative: When negative

moment exists, the deck shall be designed to act only as a permanent form.

Commentary: Composite steel deck does not function as compression reinforcing steel in areas of negative moment. If the designer wants a continuous slab, then negative bending reinforcing should be designed using conventional reinforced concrete design techniques in compliance with the *ACI Building Code Requirements for Reinforced Concrete*. The welded wire fabric, chosen for temperature reinforcing, may not supply enough area for continuity. The deck is not considered to be compression reinforcement. Typically negative reinforcement is required at all cantilevered slabs, or if a continuous slab is desired.

c. Distribution: When localized loads exceed the published uniform composite deck load tables, the designer shall proportion distribution reinforcement using conventional concrete design methods.

Commentary: Distribution steel may be required in addition to the welded wire fabric or steel fibers. Concentrated loads, either during construction or in-service, are the most common example of this requirement. Concentrated loads may be analyzed by the methods in the latest *SDI Composite Deck Design Handbook*.

7. Cantilever Loads: When cantilevered slabs are encountered, the deck acts only as a permanent form; top reinforcing steel shall be proportioned by the designer. For construction loads, the deck shall be designed for the more severe of (a) deck plus slab weight plus 20 psf (1 kPa) construction load on both cantilever and adjacent span, or (b) deck plus slab weight on

both cantilever and adjacent span plus a 150 pound (665N) concentrated load per foot of width at end of cantilever. The load factors for bending, shear, and interior bearing shall be as required by ASCE 7. Resistance factors for bending, shear, and interior bearing shall be in accordance with the *North American Specification for the Design of Cold Formed Structural Members*.

The maximum cantilever deflection as a form, under deck plus slab weight, shall be $a/90$ where "a" is the cantilever length, and shall not exceed 3/4 inches (19 mm).

Side laps shall be attached at the end of the cantilever and a maximum spacing of 12 inches (300 mm) o.c. from the cantilever end. Each corrugation shall be fastened at both the perimeter support and the first interior support. The deck shall be completely attached to the supports and at the side laps before any load is applied to the cantilever. Concrete shall not be placed on the cantilever until after placement on the adjacent span.

8. Diaphragm Shear Capacity: Diaphragms with concrete shall be designed in accordance with the *SDI Diaphragm Design Manual*, or from tests conducted by an independent professional engineer.

Commentary: Calculations of diaphragm strength and stiffness should be made using the *SDI Diaphragm Design Manual*. If testing is used as the means for determining the diaphragm strength and stiffness, then it should follow the AISI TS 7-02 test protocol.

2.5 Accessories:

- A. Pour stops, column closures, end closures, cover plates, and girder fillers shall be the type suitable for the application. Pour stop minimum gages shall be in accordance with the Steel Deck Institute. (See *Pour Stop Selection Table*, Attachment C2)
- B. Mechanical fasteners or welds shall be permitted for deck and accessory attachment.

3. Execution

3.1 Installation/ General:

- A. Support framing and field conditions shall be examined for compliance with installation tolerances and other conditions affecting performance of work of this section. All OSHA rules for erection shall be followed.
- B. Deck panels shall be installed on a concrete support structure only after the concrete has attained 75% of its specified design strength.
- C. Deck panels and accessories shall be installed according to the *SDI Manual of Construction with Steel Deck*, placement plans, and requirements of this Section.
- D. Temporary shoring, if required, shall be installed before placing deck panels. Temporary shoring shall be designed to resist a minimum uniform load of 50 psf (2.4 kPa), and loading criteria indicated on Attachment C1. Shoring shall be securely in place before the floor deck erection begins. The shoring shall be designed and installed in accordance with the *ACI Building Code Requirements for Reinforced Concrete* and shall be left in place until the slab attains 75% of its specified

design strength and a minimum of seven (7) days.

- E. Deck panels shall be placed on structural supports and adjusted to final position with ends aligned, and attached securely to the supports immediately after placement in order to form a safe working platform. All deck sheets shall have adequate bearing and fastening to all supports to prevent slip off during construction. Deck ends over supports shall be installed with a minimum end bearing of 1-1/2 inches (38 mm). Deck areas subject to heavy or repeated traffic, concentrated loads, impact loads, wheel loads, etc. shall be adequately protected by planking or other approved means to avoid overloading and/or damage.
- F. Butted Ends: Deck ends shall be butted over supports.

Commentary: Lapping composite deck ends can be difficult because shear lugs (web embossment) or profile shape can prevent a tight metal to metal fit. The space between lapped sheets can make welded attachments more difficult. Gaps are acceptable up to 1" (25 mm) at butted ends.

- G. Deck units and accessories shall be cut and neatly fit around scheduled openings and other work projecting through or adjacent to the decking.

Commentary: It is the responsibility of the designer to designate holes/openings to be decked over in compliance with applicable federal and state OSHA directives. Care should be taken to analyze spans between supports at openings when determining those holes/openings to be decked over. When a framed opening span exceeds the maximum deck span limits for

ANSI/SDI-C1.0 Standard for Composite Steel Floor Deck

construction loads, the opening must be detailed around instead of decked over. (Minimum floor construction load 50 lbs./sq. ft. (2.4 kPa), unless specific requirements dictate otherwise).

When a framed hole/opening in floor deck is shown and dimensioned on the structural design drawings, pour stop (screed) angle is required to top of slab. When specified, cell closure angle will be provided at the open ends of deck in standard 10'-0" (3 m) lengths to be field sized, cut and installed. Alternate means to dam concrete may be used in lieu of cell closure, at the discretion of the installer, if approved by the designer.

When a hole/opening is not shown and dimensioned on the structural design drawings, no provisions for concrete retainage will be provided by the metal deck manufacturer/supplier. Metal floor decking holes and openings to be cut after the concrete pour shall not be field cut until concrete has reached 75% of its design strength and a minimum of seven (7) days.

H. Trades that subsequently cut unscheduled openings through the deck shall be responsible for reinforcing these openings based upon an approved engineered design.

3.2 Installation/Anchorage:

A. Floor deck units shall be anchored to steel supporting members including perimeter support steel and/or bearing walls by arc spot puddle welds of the following diameter and spacing, fillet welds of equal strength, or mechanical fasteners.

1. All welding of deck shall be in strict accordance with ANSI/AWS D1.3, *Structural Welding Code-Sheet Steel*. Each welder shall

demonstrate an ability to produce satisfactory welds using a procedure such as shown in the *SDI Manual of Construction with Steel Deck*, or as described in ANSI/AWS D1.3.

2. A minimum visible 5/8 inch (15 mm) diameter arc puddle weld shall be used. Weld metal shall penetrate all layers of deck material, and shall have good fusion to the supporting members.
3. Edge ribs of panels shall be welded at each support. Space additional welds an average of 12 inches (300 mm) apart but not more than 18 inches (460 mm).
4. When used, fillet welds shall be at least 1-1/2 inches (38 mm) long.
5. Mechanical fasteners, either powder actuated, pneumatically driven, or screws, shall be permitted in lieu of welding to fasten deck to supporting framing if fasteners meet all project service requirements. When the fasteners are powder actuated or pneumatically driven, the load value per fastener used to determine the maximum fastener spacing is based on a minimum structural support thickness of not less than 1/8 inch (3 mm) and on the fastener providing a minimum 5/16 inch (8 mm) diameter bearing surface (fastener head size). When the structural support thickness is less than 1/8 inch (3 mm), powder actuated or pneumatically driven fasteners shall not be used, but screws are acceptable.

Commentary: Mechanical fasteners (screws, powder or pneumatically driven fasteners, etc.) are recognized as viable anchoring methods, provided

the type and spacing of the fastener satisfies the design criteria. Documentation in the form of test data, design calculations, or design charts should be submitted by the fastener manufacturer as the basis for obtaining approval.

6. For deck units with spans greater than 5 feet (1.5 m), side laps and perimeter edges of units between span supports shall be fastened at intervals not exceeding 36 inches (1 m) on center, using one of the following methods:
 - a. #10 self drilling screws
 - b. Crimp or button punch
 - c. Arc puddle welds 5/8 inch (15 mm) minimum visible diameter, or minimum 1 inch (25 mm) long fillet weld.

Commentary: The above side lap spacing is a minimum. Service loads or diaphragm design may require closer spacing or larger side lap welds. Good metal to metal contact is necessary for a good side lap weld. Burn holes are to be expected.

B. Accessory Attachment:

1. Pour Stop and Girder Fillers: Pour stops and girder fillers shall be fastened to supporting structure in accordance with the *SDI Standard Practice Details, and Attachment C2*.
2. Floor Deck Closures: Column closures, cell closures, girder closures and Z closures shall be fastened to provide tight fitting closures at open ends of ribs and sides of decking. Fasten cell closures at changes of direction of floor deck units unless otherwise directed.

Form Deck General Information

TABLES

The most common use of form deck is to support concrete fills but they can be used for a variety of structural applications. Therefore, two sets of tables are shown. The **Uniform Load tables** are for the deck as the sole load carrying member; ASD and LRFD tables both show **stress load/deflection load** in psf. The loads are uniformly applied and the deflection limit is 1/180 of the span. It is acceptable to ignore the contribution of insulation fill and to use the load tables for the appropriate form deck. When BV or NV is used, the tables are shown in the roof deck section. The **Concrete Slab tables** show the slab capacities for structural (normal weight) concrete with draped mesh placed over the various form decks. The effects of the deck profile are considered in determining the slab load values. The transformed moment of inertia (I) is provided for deflection checks. Diaphragm tables are available in the Diaphragm section of the catalog.

DESIGN CONSIDERATIONS - SLABS ON FORM DECK

The live loads shown in the tables are the loads that the reinforced concrete slab can carry. Live loads are based on unshored galvanized deck. See the maximum recommended unshored span tables and the corresponding notes. If uncoated form is used, or if shoring is used, the load shown in the table must either be reduced by the weight of the slab (the quick method) or, more precisely, by solving the equation:

$$M = 1.2M_{DL} + 1.6M_{LL}$$

M_{DL} is the moment caused by the slab weight.

Load values shown in the tables are for continuous (3 or more) spans; $-M = WL^2/12$ for spans less than 10 feet, or $WL^2/10$ for spans greater than 10 feet, and $+M = WL^2/16$ per ACI 318 (see page 85). In most cases negative moments control. Load values for end spans, dual spans, single spans, or for unequal adjacent spans should be appropriately reduced to compensate for increased moment coefficients; use the tabulated factored design moments to determine the allowable design loads. A design tool is also available on the Canam website to determine these uniform loads. All slab tables included in this section are for 3,000 psi concrete and utilize a phi factor of 0.9. Consult ACI 318 for the appropriate phi factor if the concrete exceeds 4,000 psi.

Example 1:

Check the end span of a 4" slab with welded wire mesh 6 x 6 - W4.0 x W4.0; the slab is continuous over 4' spans. The UFX deck is to be unshored and is galvanized.

$$\begin{aligned} \text{End span:} & \quad +M = WL^2/11 \\ \text{From the UFX table:} & \quad +M = 10.785 \text{ kip in.} \\ & \quad W(4)^2(12)/11 = 10.785(1000)/1.6 \\ & \quad W = 386 \text{ psf} \end{aligned}$$

-M at the first interior support controls and the table value of $W = 368$ psf is therefore the limiting load.

Example 2:

Use the same parameters of the previous example to check a single span – the mesh is not draped but is placed on top of the deck.

$$\begin{aligned} +M &= W(4)^2(12)/8 = 10.785(1000)/1.6 \\ W &= 281 \text{ psf} \end{aligned}$$

Example 3:

A 4" slab on UFX is spanning 6'; the mesh is 6 x 6 - W4.0 x W4.0. The deck was shored during construction. Determine the allowable live load.

$$\begin{aligned} \text{Quick Method:} & \quad \text{The table shows } W = 163 \text{ psf} \\ & \quad \text{The slab weighs 40 psf. The live load is then:} \\ & \quad W_{LL} = 163 - 40 - 1(\text{deck weight}) = 122 \text{ psf} \\ \text{Precise Method:} & \quad M = 9408 \text{ lb inches} = WL^2/12 \\ & \quad M_{DL} = 1.2(40+1)(6)^2(12)/12 = 1771 \text{ lb inches} \\ & \quad 9408 = 1771 + 1.6W_{LL}(6)^2(12)/12 \\ & \quad W_{LL} = 133 \text{ psf} \end{aligned}$$

In the slab capacity tables, shear has been checked for uniform loads. The factored nominal shear force is:

$$\phi V_n = 0.75 \times 2 \times (f'_c)^{.5} \times A_c$$

(A_c is the area of concrete as defined by SDI – see the **Content of Composite Deck Tables on page 29** for further explanation of A_c .)

The table values are based on $f'_c = 3000$ psi and, for the reinforcing steel (welded wire fabric), $F_y = 60,000$ psi.

values in the table represent uniform live loads greater than 400 psf. Loads higher than this limit are usually caused by concentrated loads such as those caused by fork lift trucks. When heavy concentrated loads are to be considered, the slab system, including supports, should be given additional analysis. Slab span to depth ratios are limited to 24. Spot checks have shown that the tabulated (live) loads would not cause a deflection greater than L/360. **In no case should the table values be used to predict slab performance using randomly placed fibers in lieu of wire mesh. Fibrous admixtures are not to be considered as primary reinforcement.**

In some short span layouts, the galvanized form deck is capable of carrying all of the required loading without considering the concrete slab strength. For these cases a minimum of 6 x 6-W1.4 x W1.4 is recommended for crack control.

CONCRETE AND PLACING CONCRETE

To prevent leakage at side laps, concrete should be placed in the opposite direction to which the sheets were erected so that the concrete flow is away from the lap rather than into the lap. Care should be taken during pouring operations not to allow heavy concentrated loads or equipment to be placed on the steel forms. When buggies are used to deliver the concrete, the runways should be planked to avoid local damage. Concrete admixtures containing calcium chloride (or other salts) should not be used over steel forms.

FASTENING

Welding patterns 1 and 2 on page 73 represent minimum acceptable fastening that will allow slabs to be designed on a continuous basis and also stabilize joists. More frequent fastening may be required to satisfy diaphragm or fire rating requirements. Consult the U.L. Fire Resistance Directory for specific details on fire rated constructions. Diaphragm values can be obtained from the SDI Diaphragm Design Manual or in the diaphragm section of the catalog.

Welding washers are recommended for attaching deck lighter than 22 gage to structural steel (or joists). Welding washers are not recommended for attaching deck that is 22 gage or heavier. Welding washers are never recommended for attaching side laps except at supports. Welding washers furnished by Canam are 16 gage with 3/8" diameter holes. The welder strikes an arc, burns a hole through the sheet and builds a plug weld from the joist (or beam) into the washer. Fasteners other than welds are acceptable to Canam providing that the designer has checked all of the design parameters of the fasteners.



FINISHES

Form deck is commonly available in two finishes, galvanized (conforming to ASTM A653) and uncoated (black – conforming to ATSM A1008). Galvanized steel should always be specified for carrying non-structural insulating concrete fills. Painted form deck is available on special order. Use galvanized deck for vented deck or when spray fireproofing is required.



GENERAL INFORMATION



Details

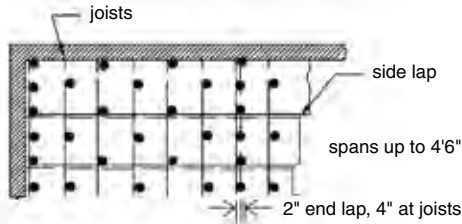

MINIMUM WELD PATTERN #1

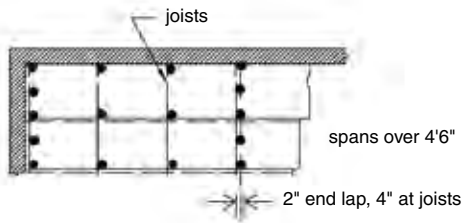

MINIMUM WELD PATTERN #2

Note: dots represent welds. Fasten side laps at 36" o.c. (max) if span exceeds 5'0".

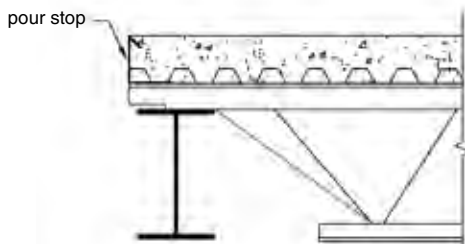

DETAIL AT SPANDREL

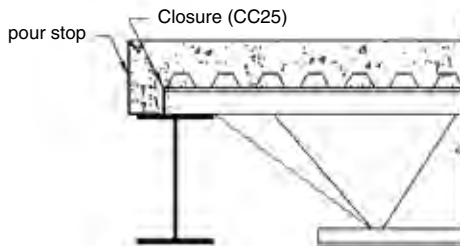

DETAIL AT SPANDREL

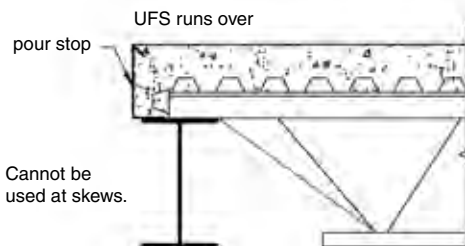

ALTERNATE DETAIL AT SPANDREL

Suggested Form Deck Specifications

1. Material

DECK

Steel form deck shall be UNITED STEEL DECK as manufactured by Canam. Steel shall conform to one of the following:

- (1) ASTM A1008 SS grade 80 (for uncoated UFS, UF1X, UFX, and UF2X);
- (2) ASTM A653 SS grade 80 (for galvanized UFS, UFSV, UF1X, UF1XV, UFX, UFXV, UF2X, and UF2XV);
- (3) ASTM A1008 SS grade 40 (for painted or uncoated B or Inv. B deck);
- (4) ASTM A653 SS grade 40 (for galvanized B, BV, Inv. B, N, NV, LF2X, LF3X, or LS deck);
- (5) ASTM A653 SS grade 33 or grade 40 (for galvanized HPD deck).

VENTING – (if required – V at end of product name indicates availability.)

Deck shall be galvanized and provide a minimum venting area of XX percent based on the projected horizontal area. (Maximum area available for NV is 0.5%, all others are 1.5%. Venting area requirements should be obtained from the concrete manufacturer.) The form deck section of the catalog includes load tables for both vented and non-vented form deck. With insulating fill it is acceptable to ignore the contribution of the fill. When BV or NV is used, use the load table in the roof deck section. However, insulating fill manufacturers have determined load capacities of various combinations of fill and deck both with and without foamed plastic insulations boards. Refer to the fill manufacturer's literature for more specific loading limitations. Some dripping and deck staining is to be expected at vents.

2. Design

The section properties of the steel form units shall be calculated in accordance with the AISI North American Specification for the Design of Cold-Formed Steel Structural Members.

For Allowable Stress Design (ASD) of forms:

- (1) Bending stress for UFS(V), UF1X(V), UFX(V), or UF2X(V) shall not exceed 36 ksi; or
- (2) Bending stress for B (V), Inv. B, N(V), LF2X, LF3X, LS, or grade 40 HPD shall not exceed 24 ksi;
- (3) Bending stress for grade 33 HPD shall not exceed 20 ksi;
- (4) Deck used as a form for structural concrete slabs shall meet SDI construction loading criteria.

For LRFD:

- (1) The steel yield stress for UFS(V), UF1X(V), UFX(V), or UF2X(V) is 60 ksi.
- (2) Deck used as a form for structural concrete shall meet SDI construction loading criteria.

Note: Shoring impacts slab live load capacity.

See the form deck general information section.

3. Tolerances

The standard tolerance for deck sheet lengths is plus or minus 1/2". Base steel thickness tolerance is minus 5% as per SDI and AISI.

4. Installation

Steel Deck shall be erected and fastened in accordance with the project's specifications, the approved erection layouts, and the *SDI Manual of Construction with Steel Deck*. Place form deck sheets end to end and maintain alignment. **In order to form a working platform, immediately fasten sheets to the supports.** Place sheets with edges up and end lapped or butted at the ends over supports; nest side laps one-half corrugation. Minimum bearing on supports of deck ends shall be 1 1/2" unless otherwise shown.

Welding washers are required for attaching deck lighter than 22 gage to structural steel (or joists). *Welding washers are not recommended for attaching deck that is 22 gage or heavier. Welding washers are never recommended for attaching side laps except at supports.* Welding washers, when required, shall be furnished by Canam. For thicknesses 22 gage and greater, arc puddle welds shall be at least 5/8 inch in diameter, or elongated, having an equal perimeter. Support arc puddle welds shall be 3/4 inch in diameter or elongated arc seam welds having equal perimeter when either the combined thickness at end laps exceeds 20/18 or the single thickness is equal to or greater than 12 gage. Side laps are to be fastened at a maximum spacing of 36" on center for spans greater than 5'0". Fasten side laps at 12" on center at cantilevers. *Welds or screws are acceptable for side lap connections, however welds are not recommended for thickness 22 gage and less.* HPD side laps are to be fastened at 24" on center with 1" minimum butt welds. All sheets from opened bundles must be fastened before the end of the working day; bundles must be left secured to prevent wind blowing the individual sheets.

5. Site Storage

Steel deck delivery should be scheduled to arrive at the jobsite as required for erection. If site storage is needed, the bundles of deck (either painted, uncoated, or galvanized) shall be stored off the ground with one end elevated to provide drainage, and shall be protected against condensation with a ventilated waterproof covering.

SPECIFICATIONS

UFS, UFSV - $F_y = 80$ ksi											
Section Properties						ASD			LRFD		
Metal Thickness		Wt. (psf)	I_p (in ⁴)	S_p (in ³)	S_n (in ³)	V (lbs)	R_{be} (lbs)	R_{bi} (lbs)	ϕV (lbs)	ϕR_{be} (lbs)	ϕR_{bi} (lbs)
Gage	Inches										
28	0.0149	0.8	0.011	0.036	0.037	1320	670	800	2010	1020	1180
26	0.0179	0.9	0.014	0.045	0.047	1580	930	1140	2410	1430	1690
24	0.0239	1.2	0.019	0.063	0.063	2100	1570	1980	3190	2390	2950
22	0.0295	1.5	0.023	0.078	0.078	2580	2290	2960	3920	3500	4400
20	0.0358	1.8	0.028	0.094	0.094	3110	3240	4260	4730	4950	6340

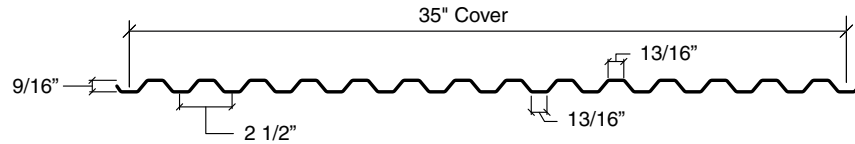

UFS, UFSV

UNIFORM TOTAL LOAD / Load that Produces L/180 Deflection, psf											
Gage	Span Condition	Span									
		2'0"	2'6"	3'0"	3'6"	4'0"	4'6"	5'0"	5'6"	6'0"	
ASD	28	Single	216 / 120	138 / 62	96 / 36	71 / 22	54 / 15	43 / 11	35 / 8	29 / 6	24 / 4
		Double	217 / 290	140 / 148	98 / 86	72 / 54	55 / 36	44 / 25	35 / 19	29 / 14	25 / 11
		Triple	269 / 227	174 / 116	122 / 67	90 / 42	69 / 28	54 / 20	44 / 15	37 / 11	31 / 8
	26	Single	270 / 153	173 / 78	120 / 45	88 / 29	67 / 19	53 / 13	43 / 10	36 / 7	30 / 6
		Double	275 / 369	178 / 189	124 / 109	91 / 69	70 / 46	55 / 32	45 / 24	37 / 18	31 / 14
		Triple	341 / 289	221 / 148	154 / 86	114 / 54	87 / 36	69 / 25	56 / 18	46 / 14	39 / 11
	24	Single	378 / 208	242 / 106	168 / 62	123 / 39	94 / 26	75 / 18	60 / 13	50 / 10	42 / 8
		Double	369 / 501	238 / 256	166 / 148	122 / 93	94 / 63	74 / 44	60 / 32	50 / 24	42 / 19
		Triple	456 / 392	296 / 201	207 / 116	152 / 73	117 / 49	93 / 34	75 / 25	62 / 19	52 / 15
	22	Single	468 / 252	300 / 129	208 / 75	153 / 47	117 / 31	92 / 22	75 / 16	62 / 12	52 / 9
		Double	456 / 606	295 / 310	206 / 180	152 / 113	116 / 76	92 / 53	75 / 39	62 / 29	52 / 22
		Triple	564 / 474	366 / 243	256 / 141	189 / 88	145 / 59	115 / 42	93 / 30	77 / 23	65 / 18
20	Single	564 / 306	361 / 157	251 / 91	184 / 57	141 / 38	111 / 27	90 / 20	75 / 15	63 / 11	
	Double	550 / 738	355 / 378	248 / 219	183 / 138	140 / 92	111 / 65	90 / 47	74 / 35	62 / 27	
	Triple	680 / 577	441 / 296	308 / 171	227 / 108	175 / 72	138 / 51	112 / 37	93 / 28	78 / 21	
LRFD	28	Single	342 / 120	219 / 62	152 / 36	112 / 22	85 / 15	68 / 11	55 / 8	45 / 6	38 / 4
		Double	343 / 290	222 / 148	155 / 86	114 / 54	87 / 36	69 / 25	56 / 19	46 / 14	39 / 11
		Triple	425 / 227	275 / 116	192 / 67	142 / 42	109 / 28	86 / 20	70 / 15	58 / 11	49 / 8
	26	Single	428 / 153	274 / 78	190 / 45	140 / 29	107 / 19	84 / 13	68 / 10	57 / 7	48 / 6
		Double	435 / 369	281 / 189	196 / 109	145 / 69	111 / 46	88 / 32	71 / 24	59 / 18	49 / 14
		Triple	538 / 289	349 / 148	244 / 86	180 / 54	138 / 36	109 / 25	89 / 18	73 / 14	62 / 11
	24	Single	599 / 208	383 / 106	266 / 62	195 / 39	150 / 26	118 / 18	96 / 13	79 / 10	67 / 8
		Double	583 / 501	376 / 256	263 / 148	194 / 93	149 / 63	118 / 44	95 / 32	79 / 24	66 / 19
		Triple	720 / 392	467 / 201	327 / 116	241 / 73	185 / 49	147 / 34	119 / 25	98 / 19	83 / 15
	22	Single	741 / 252	474 / 129	329 / 75	242 / 47	185 / 31	146 / 22	119 / 16	98 / 12	82 / 9
		Double	721 / 606	466 / 310	325 / 180	240 / 113	184 / 76	146 / 53	118 / 39	98 / 29	82 / 22
		Triple	891 / 474	578 / 243	405 / 141	299 / 88	229 / 59	182 / 42	147 / 30	122 / 23	102 / 18
20	Single	893 / 306	572 / 157	397 / 91	292 / 57	223 / 38	176 / 27	143 / 20	118 / 15	99 / 11	
	Double	869 / 738	562 / 378	392 / 219	289 / 138	222 / 92	175 / 65	142 / 47	118 / 35	99 / 27	
	Triple	1074 / 577	697 / 296	487 / 171	360 / 108	276 / 72	219 / 51	177 / 37	147 / 28	123 / 21	

NOTES:

Vented deck with 1.5% maximum open area is available for use with insulating fills. It is acceptable to ignore the contribution of the insulating fill and use the load table above, however, insulating fill manufacturers have determined load capacities of various combinations of fill and deck both with and without foamed plastic insulation boards. Refer to the fill manufacturer's literature for more specific loading limitations.

R_{be} is the bearing capacity at an exterior condition based on 1 1/2" of bearing. R_{bi} is the bearing capacity at an interior condition based on 3" of bearing.

UFS, UFSV

UF1X, UF1XV - F _y = 80 ksi											
Section Properties						ASD			LRFD		
Metal Thickness		Wt. (psf)	I _p (in ⁴)	S _p (in ³)	S _n (in ³)	V (lbs)	R _{be} (lbs)	R _{bi} (lbs)	φV (lbs)	φR _{be} (lbs)	φR _{bi} (lbs)
Gage	Inches										
26	0.0179	1.0	0.039	0.067	0.072	1540	460	660	2340	710	970
24	0.0239	1.3	0.055	0.098	0.105	2170	790	1170	3300	1210	1740
22	0.0295	1.6	0.071	0.129	0.137	2670	1170	1760	4070	1780	2620
20	0.0358	1.9	0.090	0.166	0.170	3240	1660	2550	4920	2550	3800

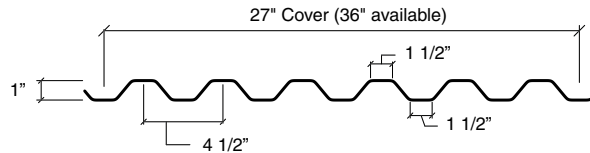

The bottom flange can accept a 3/4" shear stud.

UF1X, UF1XV

UNIFORM TOTAL LOAD / Load that Produces L/180 Deflection, psf											
Gage	Span Condition	Span									
		3'0"	3'6"	4'0"	4'6"	5'0"	5'6"	6'0"	6'6"	7'0"	
ASD	26	Single	179 / 126	131 / 80	101 / 53	79 / 37	64 / 27	53 / 21	45 / 16	38 / 12	33 / 10
		Double	176 / 304	138 / 192	106 / 128	84 / 90	68 / 66	57 / 49	48 / 38	41 / 30	35 / 24
		Triple	200 / 238	171 / 150	132 / 101	105 / 71	85 / 51	71 / 39	59 / 30	51 / 23	44 / 19
	24	Single	261 / 178	192 / 112	147 / 75	116 / 53	94 / 39	78 / 29	65 / 22	56 / 18	48 / 14
		Double	272 / 429	201 / 270	155 / 181	123 / 127	100 / 93	83 / 70	69 / 54	59 / 42	51 / 34
		Triple	336 / 336	250 / 212	192 / 142	153 / 100	124 / 73	103 / 55	87 / 42	74 / 33	64 / 26
	22	Single	344 / 230	253 / 145	194 / 97	153 / 68	124 / 50	102 / 37	86 / 29	73 / 23	63 / 18
		Double	354 / 554	262 / 349	202 / 234	160 / 164	130 / 120	108 / 90	91 / 69	77 / 54	67 / 44
		Triple	436 / 434	324 / 273	250 / 183	199 / 129	162 / 94	134 / 70	113 / 54	96 / 43	83 / 34
	20	Single	443 / 292	325 / 184	249 / 123	197 / 86	159 / 63	132 / 47	111 / 36	94 / 29	81 / 23
		Double	438 / 703	325 / 442	250 / 296	198 / 208	161 / 152	134 / 114	112 / 88	96 / 69	83 / 55
		Triple	541 / 550	402 / 346	310 / 232	246 / 163	200 / 119	166 / 89	140 / 69	119 / 54	103 / 43
LRFD	26	Single	283 / 126	208 / 80	159 / 53	126 / 37	102 / 27	84 / 21	71 / 16	60 / 12	52 / 10
		Double	259 / 304	219 / 192	168 / 128	133 / 90	108 / 66	90 / 49	75 / 38	64 / 30	56 / 24
		Triple	294 / 238	252 / 150	209 / 101	166 / 71	135 / 51	112 / 39	94 / 30	80 / 23	69 / 19
	24	Single	414 / 178	304 / 112	233 / 75	184 / 53	149 / 39	123 / 29	103 / 22	88 / 18	76 / 14
		Double	430 / 429	318 / 270	245 / 181	194 / 127	158 / 93	131 / 70	110 / 54	94 / 42	81 / 34
		Triple	527 / 336	394 / 212	304 / 142	241 / 100	196 / 73	163 / 55	137 / 42	117 / 33	101 / 26
	22	Single	545 / 230	400 / 145	306 / 97	242 / 68	196 / 50	162 / 37	136 / 29	116 / 23	100 / 18
		Double	559 / 554	414 / 349	319 / 234	253 / 164	206 / 120	170 / 90	143 / 69	122 / 54	106 / 44
		Triple	689 / 434	512 / 273	396 / 183	314 / 129	256 / 94	212 / 70	178 / 54	152 / 43	132 / 34
	20	Single	701 / 292	515 / 184	394 / 123	312 / 86	252 / 63	209 / 47	175 / 36	149 / 29	129 / 23
		Double	692 / 703	513 / 442	396 / 296	314 / 208	255 / 152	211 / 114	178 / 88	152 / 69	131 / 55
		Triple	852 / 550	635 / 346	490 / 232	390 / 163	317 / 119	263 / 89	221 / 69	189 / 54	163 / 43

NOTES:

Vented deck with 1.5% maximum open area is available for use with insulating fills. It is acceptable to ignore the contribution of the insulating fill and use the load table above, however, insulating fill manufacturers have determined load capacities of various combinations of fill and deck both with and without foamed plastic insulation boards. Refer to the fill manufacturer's literature for more specific loading limitations.

R_{be} is the bearing capacity at an exterior condition based on 1 1/2" of bearing. R_{bi} is the bearing capacity at an interior condition based on 3" of bearing.

UF1X, UF1XV

UFX, UFXV - $F_y = 80$ ksi											
Section Properties						ASD			LRFD		
Metal Thickness		Wt. (psf)	I_p (in ⁴)	S_p (in ³)	S_n (in ³)	V (lbs)	R_{be} (lbs)	R_{bi} (lbs)	ϕV (lbs)	ϕR_{be} (lbs)	ϕR_{bi} (lbs)
Gage	Inches										
26	0.0179	1.0	0.065	0.086	0.089	1410	410	620	2150	630	920
24	0.0239	1.3	0.092	0.125	0.129	2520	710	1090	3830	1090	1630
22	0.0295	1.6	0.119	0.165	0.169	3230	1050	1650	4910	1610	2450
20	0.0358	2.0	0.151	0.213	0.218	3910	1500	2390	5940	2300	3550

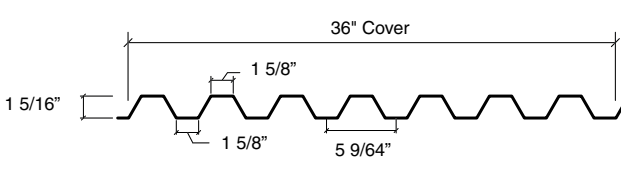

The bottom flange can accept a 3/4" shear stud.

UFX, UFXV

UNIFORM TOTAL LOAD / Load that Produces L/180 Deflection, psf											
Gage	Span Condition	Span									
		4'0"	4'6"	5'0"	5'6"	6'0"	6'6"	7'0"	7'6"	8'0"	
ASD	26	Single	129 / 89	102 / 62	83 / 46	68 / 34	57 / 26	49 / 21	42 / 17	37 / 13	32 / 11
		Double	124 / 214	103 / 150	84 / 110	70 / 82	59 / 63	50 / 50	43 / 40	38 / 32	33 / 27
		Triple	141 / 168	125 / 118	104 / 86	86 / 64	73 / 50	62 / 39	54 / 31	47 / 25	41 / 21
	24	Single	188 / 126	148 / 88	120 / 64	99 / 48	83 / 37	71 / 29	61 / 23	53 / 19	47 / 16
		Double	190 / 303	151 / 213	122 / 155	101 / 117	85 / 90	73 / 71	63 / 57	55 / 46	48 / 38
		Triple	236 / 237	187 / 167	152 / 121	126 / 91	106 / 70	91 / 55	78 / 44	68 / 36	60 / 30
	22	Single	248 / 163	196 / 114	158 / 83	131 / 63	110 / 48	94 / 38	81 / 30	70 / 25	62 / 20
		Double	249 / 392	197 / 275	160 / 201	133 / 151	112 / 116	95 / 91	82 / 73	72 / 59	63 / 49
		Triple	308 / 307	245 / 215	199 / 157	165 / 118	139 / 91	119 / 71	103 / 57	89 / 47	79 / 38
	20	Single	320 / 207	252 / 145	204 / 106	169 / 79	142 / 61	121 / 48	104 / 39	91 / 31	80 / 26
		Double	320 / 497	254 / 349	206 / 255	171 / 191	144 / 147	123 / 116	106 / 93	92 / 75	81 / 62
		Triple	396 / 389	315 / 273	256 / 199	213 / 150	179 / 115	153 / 91	132 / 73	115 / 59	101 / 49
LRFD	26	Single	204 / 89	161 / 62	131 / 46	108 / 34	91 / 26	77 / 21	67 / 17	58 / 13	51 / 11
		Double	184 / 214	163 / 150	133 / 110	110 / 82	93 / 63	79 / 50	68 / 40	60 / 32	52 / 27
		Triple	209 / 168	186 / 118	165 / 86	137 / 64	115 / 50	98 / 39	85 / 31	74 / 25	65 / 21
	24	Single	297 / 126	235 / 88	190 / 64	157 / 48	132 / 37	112 / 29	97 / 23	84 / 19	74 / 16
		Double	300 / 303	238 / 213	194 / 155	160 / 117	135 / 90	115 / 71	99 / 57	87 / 46	76 / 38
		Triple	370 / 237	296 / 167	241 / 121	200 / 91	168 / 70	143 / 55	124 / 44	108 / 36	95 / 30
	22	Single	392 / 163	310 / 114	251 / 83	207 / 63	174 / 48	148 / 38	128 / 30	111 / 25	98 / 20
		Double	393 / 392	312 / 275	254 / 201	210 / 151	177 / 116	151 / 91	130 / 73	113 / 59	100 / 49
		Triple	487 / 307	387 / 215	315 / 157	261 / 118	220 / 91	188 / 71	162 / 57	142 / 47	124 / 38
	20	Single	506 / 207	400 / 145	324 / 106	268 / 79	225 / 61	192 / 48	165 / 39	144 / 31	126 / 26
		Double	506 / 497	402 / 349	326 / 255	270 / 191	228 / 147	194 / 116	168 / 93	146 / 75	129 / 62
		Triple	626 / 389	498 / 273	405 / 199	336 / 150	283 / 115	242 / 91	209 / 73	182 / 59	160 / 49

NOTES:

Vented deck with 1.5% maximum open area is available for use with insulating fills. It is acceptable to ignore the contribution of the insulating fill and use the load table above, however, insulating fill manufacturers have determined load capacities of various combinations of fill and deck both with and without foamed plastic insulation boards. Refer to the fill manufacturer's literature for more specific loading limitations.

R_{be} is the bearing capacity at an exterior condition based on 1 1/2" of bearing. R_{bi} is the bearing capacity at an interior condition based on 3" of bearing.

UFX, UFXV

UF2X, UF2XV - $F_y = 80$ ksi											
Section Properties						ASD			LRFD		
Metal Thickness		Wt. (psf)	I_p (in ⁴)	S_p (in ³)	S_n (in ³)	V (lbs)	R_{be} (lbs)	R_{bi} (lbs)	ϕV (lbs)	ϕR_{be} (lbs)	ϕR_{bi} (lbs)
Gage	Inches										
24	0.0239	1.4	0.221	0.193	0.200	2290	770	1270	3480	1170	1890
22	0.0295	1.8	0.285	0.254	0.264	3600	1130	1890	5470	1730	2810
20	0.0358	2.1	0.361	0.327	0.341	5300	1610	2710	8050	2470	4030
18	0.0474	2.8	0.509	0.472	0.493	7230	2690	4560	10990	4120	6780

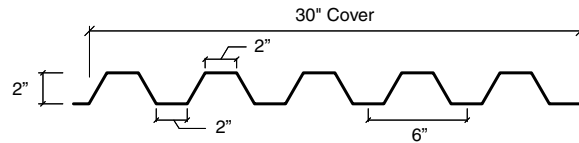

The bottom flange can accept a 3/4" shear stud.

UF2X, UF2XV

UNIFORM TOTAL LOAD / Load that Produces L/180 Deflection, psf											
Gage	Span Condition	Span									
		6'0"	6'6"	7'0"	7'6"	8'0"	8'6"	9'0"	9'6"	10'0"	
ASD	24	Single	129 / 90	110 / 70	95 / 56	82 / 46	72 / 38	64 / 32	57 / 27	51 / 23	46 / 19
		Double	130 / 216	111 / 170	96 / 136	84 / 110	74 / 91	66 / 76	59 / 64	53 / 54	48 / 47
		Triple	161 / 169	138 / 133	119 / 106	104 / 86	92 / 71	82 / 59	73 / 50	66 / 43	59 / 36
	22	Single	169 / 116	144 / 91	124 / 73	108 / 59	95 / 49	84 / 41	75 / 34	68 / 29	61 / 25
		Double	173 / 278	148 / 219	128 / 175	111 / 142	98 / 117	87 / 98	78 / 82	70 / 70	63 / 60
		Triple	215 / 218	184 / 171	159 / 137	139 / 111	122 / 92	108 / 77	97 / 64	87 / 55	79 / 47
	20	Single	218 / 146	186 / 115	160 / 92	140 / 75	123 / 62	109 / 51	97 / 43	87 / 37	78 / 32
		Double	224 / 352	192 / 277	165 / 222	144 / 180	127 / 149	113 / 124	100 / 104	90 / 89	81 / 76
		Triple	279 / 276	238 / 217	206 / 174	180 / 141	158 / 116	140 / 97	125 / 82	113 / 69	102 / 60
	18	Single	315 / 206	268 / 162	231 / 130	201 / 106	177 / 87	157 / 73	140 / 61	126 / 52	113 / 45
		Double	324 / 497	277 / 391	239 / 313	208 / 254	183 / 210	163 / 175	145 / 147	130 / 125	118 / 107
		Triple	402 / 389	344 / 306	297 / 245	259 / 199	228 / 164	203 / 137	181 / 115	163 / 98	147 / 84
LRFD	24	Single	204 / 90	174 / 70	150 / 56	130 / 46	115 / 38	102 / 32	91 / 27	81 / 23	73 / 19
		Double	206 / 216	176 / 170	152 / 136	133 / 110	117 / 91	104 / 76	93 / 64	83 / 54	75 / 47
		Triple	255 / 169	218 / 133	189 / 106	165 / 86	145 / 71	129 / 59	115 / 50	104 / 43	94 / 36
	22	Single	268 / 116	228 / 91	197 / 73	172 / 59	151 / 49	134 / 41	119 / 34	107 / 29	97 / 25
		Double	274 / 278	234 / 219	202 / 175	176 / 142	155 / 117	138 / 98	123 / 82	110 / 70	100 / 60
		Triple	340 / 218	290 / 171	251 / 137	219 / 111	193 / 92	171 / 77	153 / 64	138 / 55	124 / 47
	20	Single	345 / 146	294 / 115	254 / 92	221 / 75	194 / 62	172 / 51	153 / 43	138 / 37	124 / 32
		Double	355 / 352	303 / 277	262 / 222	228 / 180	201 / 149	178 / 124	159 / 104	143 / 89	129 / 76
		Triple	441 / 276	377 / 217	326 / 174	284 / 141	250 / 116	222 / 97	198 / 82	178 / 69	161 / 60
	18	Single	498 / 206	425 / 162	366 / 130	319 / 106	280 / 87	248 / 73	221 / 61	199 / 52	179 / 45
		Double	512 / 497	438 / 391	378 / 313	330 / 254	290 / 210	257 / 175	230 / 147	206 / 125	186 / 107
		Triple	636 / 389	544 / 306	470 / 245	410 / 199	361 / 164	321 / 137	286 / 115	257 / 98	232 / 84

NOTES:

Vented deck with 1.5% maximum open area is available for use with insulating fills. It is acceptable to ignore the contribution of the insulating fill and use the load table above, however, insulating fill manufacturers have determined load capacities of various combinations of fill and deck both with and without foamed plastic insulation boards. Refer to the fill manufacturer's literature for more specific loading limitations.

R_{be} is the bearing capacity at an exterior condition based on 2 1/2" of bearing. R_{bi} is the bearing capacity at an interior condition based on 5" of bearing.

UF2X, UF2XV

LF2X - $F_y = 40$ ksi											
Section Properties						ASD			LRFD		
Metal Thickness		Wt. (psf)	I_p (in ⁴)	S_p (in ³)	S_n (in ³)	V (lbs)	R_{be} (lbs)	R_{bi} (lbs)	ϕV (lbs)	ϕR_{be} (lbs)	ϕR_{bi} (lbs)
Gage	Inches										
22	0.0295	1.5	0.312	0.251	0.262	1420	460	800	2160	700	1190
20	0.0358	1.8	0.390	0.332	0.345	1930	520	910	2930	800	1360
19	0.0418	2.1	0.455	0.413	0.424	2250	690	1210	3410	1060	1800
18	0.0474	2.4	0.517	0.480	0.483	2540	870	1520	3860	1340	2270
16	0.0598	3.1	0.653	0.611	0.611	3200	1330	2330	4860	2040	3460

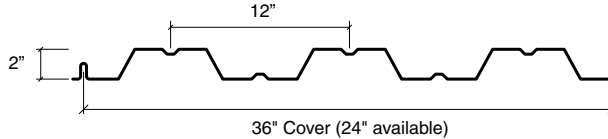

The bottom flange can accept a 3/4" shear stud.

LF2X

UNIFORM TOTAL LOAD / Load that Produces L/180 Deflection, psf											
Gage	Span Condition	Span									
		4'6"	5'0"	5'6"	6'0"	6'6"	7'0"	7'6"	8'0"	8'6"	
ASD	22	Single	198 / 300	161 / 219	133 / 164	112 / 126	95 / 99	82 / 80	71 / 65	63 / 53	56 / 44
		Double	142 / 722	128 / 526	116 / 395	107 / 304	95 / 239	83 / 192	72 / 156	64 / 128	57 / 107
		Triple	162 / 565	145 / 412	132 / 309	121 / 238	112 / 187	102 / 150	89 / 122	79 / 101	70 / 84
	20	Single	231 / 375	208 / 273	176 / 205	148 / 158	126 / 124	108 / 100	94 / 81	83 / 67	74 / 56
		Double	162 / 902	146 / 658	132 / 494	121 / 381	112 / 299	104 / 240	95 / 195	84 / 161	75 / 134
		Triple	184 / 706	165 / 515	150 / 387	138 / 298	127 / 234	118 / 188	110 / 152	103 / 126	93 / 105
	19	Single	307 / 437	264 / 319	218 / 239	184 / 184	156 / 145	135 / 116	117 / 94	103 / 78	91 / 65
		Double	215 / 1052	194 / 767	176 / 576	161 / 444	149 / 349	134 / 280	117 / 227	103 / 187	92 / 156
		Triple	244 / 824	220 / 600	200 / 451	183 / 347	169 / 273	157 / 219	144 / 178	128 / 147	113 / 122
	18	Single	379 / 497	307 / 362	254 / 272	213 / 210	182 / 165	157 / 132	137 / 107	120 / 88	106 / 74
		Double	270 / 1196	243 / 872	221 / 655	203 / 504	176 / 397	152 / 318	133 / 258	117 / 213	104 / 177
		Triple	307 / 936	276 / 682	251 / 513	230 / 395	213 / 311	187 / 249	164 / 202	145 / 167	129 / 139
16	Single	483 / 627	391 / 457	323 / 344	272 / 265	231 / 208	200 / 167	174 / 136	153 / 112	135 / 93	
	Double	414 / 1510	365 / 1101	305 / 827	259 / 637	222 / 501	192 / 401	168 / 326	149 / 269	132 / 224	
	Triple	471 / 1182	424 / 862	373 / 647	317 / 499	273 / 392	237 / 314	208 / 255	184 / 210	163 / 175	
LRFD	22	Single	311 / 300	254 / 219	210 / 164	177 / 126	151 / 99	130 / 80	113 / 65	99 / 53	88 / 44
		Double	212 / 722	190 / 526	173 / 395	159 / 304	146 / 239	131 / 192	114 / 156	101 / 128	90 / 107
		Triple	240 / 565	216 / 412	197 / 309	180 / 238	166 / 187	155 / 150	141 / 122	125 / 101	111 / 84
	20	Single	356 / 375	320 / 273	278 / 205	234 / 158	199 / 124	172 / 100	150 / 81	131 / 67	116 / 56
		Double	242 / 902	218 / 658	198 / 494	181 / 381	167 / 299	155 / 240	145 / 195	133 / 161	118 / 134
		Triple	275 / 706	247 / 515	225 / 387	206 / 298	190 / 234	177 / 188	165 / 152	155 / 126	145 / 105
	19	Single	471 / 437	419 / 319	346 / 239	291 / 184	248 / 145	214 / 116	186 / 94	163 / 78	145 / 65
		Double	320 / 1052	288 / 767	262 / 576	240 / 444	222 / 349	206 / 280	185 / 227	163 / 187	145 / 156
		Triple	364 / 824	327 / 600	298 / 451	273 / 347	252 / 273	234 / 219	218 / 178	201 / 147	179 / 122
	18	Single	596 / 497	486 / 362	402 / 272	338 / 210	288 / 165	248 / 132	216 / 107	190 / 88	168 / 74
		Double	404 / 1196	363 / 872	330 / 655	303 / 504	277 / 397	240 / 318	210 / 258	186 / 213	165 / 177
		Triple	459 / 936	413 / 682	375 / 513	344 / 395	317 / 311	295 / 249	259 / 202	229 / 167	204 / 139
16	Single	764 / 627	619 / 457	512 / 344	430 / 265	366 / 208	316 / 167	275 / 136	242 / 112	214 / 93	
	Double	615 / 1510	554 / 1101	481 / 827	408 / 637	350 / 501	304 / 401	266 / 326	235 / 269	209 / 224	
	Triple	699 / 1182	629 / 862	572 / 647	499 / 499	430 / 392	374 / 314	328 / 255	290 / 210	258 / 175	

NOTES:

R_{be} is the bearing capacity at an exterior condition based on 2 1/2" of bearing. R_{bi} is the bearing capacity at an interior condition based on 5" of bearing.

LF3X - F _y = 40 ksi											
Section Properties					ASD			LRFD			
Metal Thickness		Wt. (psf)	I _p (in ⁴)	S _p (in ³)	S _n (in ³)	V (lbs)	R _{be} (lbs)	R _{bi} (lbs)	φV (lbs)	φR _{be} (lbs)	φR _{bi} (lbs)
Gage	Inches										
22	0.0295	1.7	0.765	0.416	0.441	1450	470	850	2200	720	1270
20	0.0358	2.1	0.953	0.548	0.577	2250	540	970	3420	820	1450
19	0.0418	2.4	1.112	0.680	0.692	3070	720	1300	4660	1100	1930
18	0.0474	2.8	1.261	0.793	0.790	3880	900	1630	5900	1380	2430
16	0.0598	3.5	1.593	0.998	0.998	4880	1390	2490	7420	2120	3710

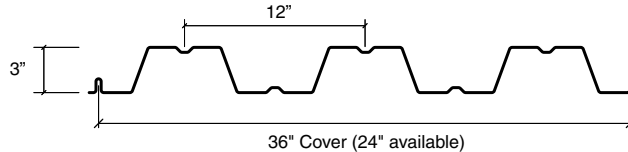

The bottom flange can accept a 3/4" shear stud.

LF3X

UNIFORM TOTAL LOAD / Load that Produces L/180 Deflection, psf											
Gage	Span Condition	Span									
		7'6"	8'0"	8'6"	9'0"	9'6"	10'0"	10'6"	11'0"	11'6"	
ASD	22	Single	118 / 159	104 / 131	92 / 109	82 / 92	74 / 78	67 / 67	60 / 58	55 / 50	50 / 44
		Double	91 / 382	85 / 315	80 / 263	76 / 221	72 / 188	68 / 161	61 / 139	56 / 121	52 / 106
		Triple	103 / 299	97 / 246	91 / 205	86 / 173	81 / 147	77 / 126	74 / 109	69 / 95	64 / 83
	20	Single	144 / 198	135 / 163	126 / 136	113 / 114	101 / 97	91 / 83	83 / 72	75 / 63	69 / 55
		Double	103 / 476	97 / 392	91 / 327	86 / 275	82 / 234	78 / 201	74 / 173	71 / 151	67 / 132
		Triple	118 / 372	110 / 307	104 / 256	98 / 215	93 / 183	88 / 157	84 / 136	80 / 118	77 / 103
	19	Single	192 / 231	170 / 190	151 / 159	134 / 134	121 / 114	109 / 97	99 / 84	90 / 73	82 / 64
		Double	139 / 556	130 / 458	122 / 382	116 / 321	109 / 273	104 / 234	98 / 202	90 / 176	82 / 154
		Triple	158 / 435	148 / 358	139 / 299	131 / 252	124 / 214	118 / 183	113 / 158	107 / 138	102 / 121
	18	Single	226 / 262	198 / 216	176 / 180	157 / 151	141 / 129	127 / 110	115 / 95	105 / 83	96 / 73
		Double	174 / 630	163 / 519	153 / 433	145 / 365	137 / 310	124 / 266	113 / 230	103 / 200	94 / 175
		Triple	198 / 493	185 / 406	174 / 339	165 / 285	156 / 243	148 / 208	140 / 180	127 / 156	117 / 137
16	Single	284 / 331	250 / 272	221 / 227	197 / 191	177 / 163	160 / 139	145 / 120	132 / 105	121 / 92	
	Double	266 / 796	242 / 656	215 / 547	192 / 461	173 / 392	156 / 336	142 / 290	130 / 252	119 / 221	
	Triple	302 / 623	283 / 513	265 / 428	238 / 360	214 / 306	194 / 263	176 / 227	161 / 197	148 / 173	
LRFD	22	Single	187 / 159	165 / 131	146 / 109	130 / 92	117 / 78	105 / 67	96 / 58	87 / 50	80 / 44
		Double	135 / 382	127 / 315	120 / 263	113 / 221	107 / 188	102 / 161	97 / 139	89 / 121	81 / 106
		Triple	154 / 299	144 / 246	136 / 205	128 / 173	122 / 147	115 / 126	110 / 109	105 / 95	100 / 83
	20	Single	219 / 198	205 / 163	193 / 136	178 / 114	160 / 97	144 / 83	131 / 72	119 / 63	109 / 55
		Double	155 / 476	145 / 392	136 / 327	129 / 275	122 / 234	116 / 201	110 / 173	105 / 151	101 / 132
		Triple	176 / 372	165 / 307	155 / 256	146 / 215	139 / 183	132 / 157	126 / 136	120 / 118	115 / 103
	19	Single	293 / 231	269 / 190	238 / 159	213 / 134	191 / 114	172 / 97	156 / 84	142 / 73	130 / 64
		Double	206 / 556	193 / 458	182 / 382	172 / 321	163 / 273	154 / 234	147 / 202	140 / 176	130 / 154
		Triple	234 / 435	219 / 358	206 / 299	195 / 252	185 / 214	175 / 183	167 / 158	160 / 138	153 / 121
	18	Single	357 / 262	314 / 216	278 / 180	248 / 151	223 / 129	201 / 110	182 / 95	166 / 83	152 / 73
		Double	259 / 630	243 / 519	229 / 433	216 / 365	205 / 310	194 / 266	178 / 230	162 / 200	149 / 175
		Triple	295 / 493	276 / 406	260 / 339	245 / 285	233 / 243	221 / 208	210 / 180	201 / 156	185 / 137
16	Single	449 / 331	395 / 272	350 / 227	312 / 191	280 / 163	253 / 139	229 / 120	209 / 105	191 / 92	
	Double	396 / 796	371 / 656	339 / 547	304 / 461	273 / 392	247 / 336	225 / 290	205 / 252	188 / 221	
	Triple	450 / 623	422 / 513	397 / 428	375 / 360	338 / 306	306 / 263	279 / 227	254 / 197	233 / 173	

NOTES:

R_{be} is the bearing capacity at an exterior condition based on 2 1/2" of bearing. R_{bi} is the bearing capacity at an interior condition based on 5" of bearing.

LF3X

Heavy Plank Deck

Heavy Duty Plank Deck is intended for uses such as heavy concrete fills.

EXAMPLE (33 ksi HPD):

The deck is to carry 18" (total depth) of concrete and span 8'. Use SDI single span loading to select the deck gage.

$$\text{Conc. Wt.} = \frac{(18 - 2.5)}{12} (145) = 187 \text{ psf}$$

$$\begin{aligned} \text{Conc. fill flutes} &= 0.1153 (145) \\ &= 17 \text{ psf} \\ &= 204 \text{ psf} \end{aligned}$$

For single spans add 50% of concrete weight or 30 psf, whichever is less.

(SDI recommendation)

$$204 \times 0.5 = 102 \text{ use } 30$$

$$\text{total concr.} = 234 \text{ psf}$$

For construction loads either use SDI loading or, for quick estimate 50 psf.

$$234 + 50 = 284 \text{ psf}$$

ASD design shows 10 gage can carry 351 psf.

SDI:

$$+M = \frac{234(8)^2(12)}{8} + \frac{150(8)(12)}{4} = 26064 \text{ inch lbs.}$$

OR

$$+M = \frac{(234 + 20)8^2(12)}{8} = 24384 \text{ inch lbs.}$$

$$\text{Req'd } S_p = \frac{26064}{20000} = 1.30 \text{ in.}^3$$

$$10 \text{ gage } S_p = 1.69 \text{ O.K.}$$

		HPD										
		Section Properties					ASD			LRFD		
	Metal Thickness Gage	Inches	Wt. (psf)	I _p (in ⁴)	S _p (in ³)	S _n (in ³)	V (lbs)	R _{be} (lbs)	R _{bi} (lbs)	φV (lbs)	φR _{be} (lbs)	φR _{bi} (lbs)
	12	0.1046	7.00	1.860	1.341	1.328	8660	5730	9850	13170	8760	14650
	10	0.1345	9.00	2.364	1.685	1.681	11015	9060	15610	16740	13860	23220
40 ksi	14	0.0747	5.00	1.344	0.980	0.959	7580	3760	6450	11530	5750	9590
	12	0.1046	7.00	1.860	1.341	1.324	10500	6940	11940	15960	10620	17760
	10	0.1345	9.00	2.364	1.685	1.677	13350	10980	18920	20290	16800	28150

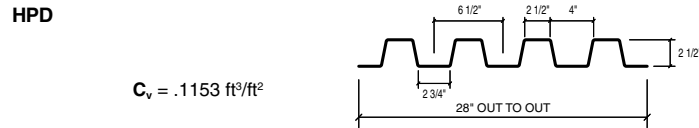

$$C_v = .1153 \text{ ft}^3/\text{ft}^2$$

		SINGLE SPAN UNIFORM TOTAL LOAD/Load that Produces L/180 Deflection, psf					
		ASD			LRFD		
	Span	14	12	10	14	12	10
		33 ksi	6'0"	363 / 545	497 / 754	624 / 958	569 / 545
	6'6"	309 / 428	423 / 593	532 / 754	485 / 428	663 / 593	834 / 754
	7'0"	267 / 343	365 / 475	459 / 603	418 / 343	572 / 475	719 / 603
	7'6"	232 / 279	318 / 386	399 / 491	364 / 279	498 / 386	626 / 491
	8'0"	204 / 230	279 / 318	351 / 404	320 / 230	438 / 318	550 / 404
	8'6"	181 / 192	247 / 265	311 / 337	283 / 192	388 / 265	487 / 337
	9'0"	161 / 161	221 / 223	277 / 284	253 / 161	346 / 223	435 / 284
	9'6"	145 / 137	198 / 190	249 / 241	227 / 137	311 / 190	390 / 241
	10'0"	131 / 118	179 / 163	225 / 207	205 / 118	280 / 163	352 / 207
	10'6"	119 / 102	162 / 141	204 / 179	186 / 102	254 / 141	319 / 179
	11'0"	108 / 88	148 / 122	186 / 155	169 / 88	232 / 122	291 / 155
	11'6"	99 / 77	135 / 107	170 / 136	155 / 77	212 / 107	266 / 136
	12'0"	91 / 68	124 / 94	156 / 120	142 / 68	195 / 94	245 / 120
40 ksi	6'0"	436 / 545	596 / 754	749 / 958	690 / 545	944 / 754	1186 / 958
	6'6"	371 / 428	508 / 593	638 / 754	588 / 428	804 / 593	1010 / 754
	7'0"	320 / 343	438 / 475	550 / 603	507 / 343	693 / 475	871 / 603
	7'6"	279 / 279	381 / 386	479 / 491	441 / 279	604 / 386	759 / 491
	8'0"	245 / 230	335 / 318	421 / 404	388 / 230	531 / 318	667 / 404
	8'6"	217 / 192	297 / 265	373 / 337	344 / 192	470 / 265	591 / 337
	9'0"	194 / 161	265 / 223	333 / 284	307 / 161	419 / 223	527 / 284
	9'6"	174 / 137	238 / 190	299 / 241	275 / 137	376 / 190	473 / 241
	10'0"	157 / 118	215 / 163	270 / 207	248 / 118	340 / 163	427 / 207
	10'6"	142 / 102	195 / 141	245 / 179	225 / 102	308 / 141	387 / 179
	11'0"	130 / 88	177 / 122	223 / 155	205 / 88	281 / 122	353 / 155
	11'6"	119 / 77	162 / 107	204 / 136	188 / 77	257 / 107	323 / 136
	12'0"	109 / 68	149 / 94	187 / 120	172 / 68	236 / 94	296 / 120

Notes:

R_{be} is the bearing capacity at an exterior condition based on 2 1/2" of bearing. R_{bi} is the bearing capacity at an interior condition based on 5" of bearing. HPD panels should be butted and fastened with 1" minimum butt welds at 24" on center. Maximum production length is 12'0".

LS Deck used as a Concrete Form

Notes:

- Material = ASTM A653 SS Grade 40. Galvanized deck is recommended.
- Deck acts as a form only. Slab must be reinforced.
- Slab thickness is the total from top of concrete to bottom of deck.
- Spans are determined using standard SDI construction loading, deflection criteria, and 3" bearing width.
- Slab design may require a reduction in span at a particular slab thickness.
- The maximum available length for all profiles is 34'0" so the table is based on a single span condition.
- All span length values are truncated to the lower inch.
- See the Roof Deck section of the catalog for the Uniform Load table for LS Deck.
- For additional tables contact Canam Engineering department.

Profile	Slab Thk	Maximum Allowable Unshored Single Span							
		Light Weight Concrete (115 pcf)				Normal Weight Concrete (145 pcf)			
		Gage				Gage			
		16	14	12	10	16	14	12	10
LS4.5 	7.5	17'9"	18'8"	20'0"	21'0"	16'10"	17'9"	19'1"	20'1"
	8.5	16'11"	17'10"	19'2"	20'2"	16'1"	16'11"	18'3"	19'3"
	9.5	16'4"	17'2"	18'6"	19'6"	15'4"	16'3"	17'7"	18'6"
LS6 	9	20'5"	21'6"	23'1"	24'3"	19'5"	20'5"	22'0"	23'2"
	10	19'7"	20'8"	22'2"	23'4"	18'7"	19'7"	21'1"	22'3"
	11	18'11"	19'11"	21'5"	22'7"	17'11"	18'11"	20'5"	21'6"
LS7.5 	10.5	22'9"	23'11"	25'8"	27'0"	21'7"	22'9"	24'5"	25'9"
	11.5	21'11"	23'1"	24'9"	26'1"	20'9"	21'11"	23'7"	24'10"
	12.5	21'2"	22'4"	24'0"	25'4"	20'1"	21'2"	22'10"	24'1"

HPD AND LS

Profile Considerations

Draped Mesh Slabs: Deck depth = h ; Total Slab Depth = D ; Wire diameter = w .

$D = 2.5''$ to $3''$
 $+d = (D - h)/2$
 $-d = (D - h)/2 + h/2 = D/2$
 TOP COVER = $0.75''$

$D > 3''$
 $-d = (D - h/2 - 3w/2 - 0.75'')$
 $+d = (D - h - w/2)$
 TOP COVER = $0.75''$

(Mesh is draped, not layered.)

$-d = (D - 0.75 - 3w/2)$
 $+d = (D - h - w/2)$
 TOP COVER = $0.75''$

(Mesh is draped, not layered.)

DRAPED MESH

UFS, UF1X and UFX-36 have a b width of 12" for both positive and negative bending. For $D < 3''$ place the mesh in the center of the concrete that is above the ribs. For $D > 3''$, mesh is draped, not layered.

Inverted B and UF2X have a b width of 12" for positive bending. For negative bending the b width for Inverted B deck is 7.5"; for UF2X the negative bending b width is 6". For $D > 3''$ mesh is draped, not layered.

Minimum concrete cover is 1 1/2"

FORM DECK - weights and volumes

Total Slab Depth		UFS	UF1X	UFX	INV. B	UF2X	LF2X	LF3X
		$C_v = .0234$	$C_v = .0417$	$C_v = .0547$	$C_v = .0781$	$C_v = .0833$	$C_v = .0833$	$C_v = .1250$
2.5"	Wt	27						
	Vol.	0.185						
3.0"	Wt	33	30	28				
	Vol.	0.226	0.208	0.195				
3.5"	Wt	39	36	34	36			
	Vol.	0.268	0.250	0.237	0.245			
4.0"	Wt	45	42	40	41	36	36	
	Vol.	0.310	0.292	0.279	0.286	0.250	0.250	
4.5"	Wt	51	48	46	48	42	42	36
	Vol.	0.352	0.333	0.320	0.328	0.292	0.292	0.250
5.0"	Wt	57	54	52	54	48	48	42
	Vol.	0.393	0.375	0.362	0.370	0.333	0.333	0.292
5.5"	Wt	63	60	59	60	54	54	48
	Vol.	0.435	0.417	0.404	0.411	0.375	0.375	0.333
6.0"	Wt	69	66	65	66	60	60	54
	Vol.	0.476	0.458	0.445	0.453	0.417	0.417	0.375
6.5"	Wt	75	73	71	72	67	67	60
	Vol.	0.518	0.500	0.487	0.495	0.458	0.458	0.417
7.0"	Wt	81	79	77	78	73	73	66
	Vol.	0.560	0.542	0.528	0.536	0.500	0.500	0.458

The weights are shown in pounds per square foot and are based on 145 pcf concrete. Volumes are in ft^3 per ft^2 . C_v is the volume of concrete required to fill the ribs. Multiply the volume shown in the table by 144 to find the gross area of concrete in in^2/ft .

SLAB DESIGN DATA



Note:
f'c = 3 ksi

Concrete slabs on UFS form deck

UNIFORM UNFACTORED SERVICE LIVE LOADS, PSF														
Slab	Mesh	+d	-d	+φM	-φM	φV	I _{av}	Spans, feet						
								2'0"	2'3"	2'6"	2'9"	3'0"	3'3"	3'6"
2.5"	6 x 6 - W1.4 x W1.4*	0.969	1.250	1.423	1.848	1.633	0.319	289	228	185	153	128	109	94
	6 x 6 - W2.0 x W2.0*	0.969	1.250	2.008	2.615	1.633	0.327	###	323	262	216	182	155	133
	6 x 6 - W2.9 x W2.9	0.969	1.250	2.856	3.737	1.633	0.338	###	###	374	309	260	221	191
3.0"	6 x 6 - W1.4 x W1.4*	1.219	1.500	1.801	2.226	1.959	0.580	348	275	223	184	155	132	114
	6 x 6 - W2.0 x W2.0*	1.219	1.500	2.548	3.155	1.959	0.592	###	390	316	261	219	187	161
	6 x 6 - W2.9 x W2.9*	1.219	1.500	3.639	4.520	1.959	0.609	###	###	###	374	314	267	231
3.5"	6 x 6 - W2.9 x W2.9*	2.842	2.181	8.721	6.652	2.286	1.106	###	###	###	###	###	394	339
	6 x 6 - W4.0 x W4.0	2.825	2.131	11.865	8.868	2.286	1.162	###	###	###	###	###	###	###
4.0"	6 x 6 - W2.9 x W2.9*	3.342	2.681	10.287	8.218	2.613	1.694	###	###	###	###	###	###	###
	6 x 6 - W4.0 x W4.0*	3.325	2.631	14.025	11.028	2.613	1.780	###	###	###	###	###	###	###

Concrete slabs on UF1X form deck

UNIFORM UNFACTORED SERVICE LIVE LOADS, PSF																	
Slab	Mesh	+d	-d	+φM	-φM	φV	I _{av}	Spans, feet									
								2'0"	2'6"	3'0"	3'6"	4'0"	4'6"	5'0"	5'6"	6'0"	6'6"
3.0"	6 x 6 - W2.0 x W2.0*	1.000	1.500	2.075	3.155	1.972	0.467	###	277	192	141	108	85	69	57	48	
	6 x 6 - W2.9 x W2.9	1.000	1.500	2.954	4.520	1.972	0.482	###	394	274	201	154	122	98	81	68	
3.5"	6 x 6 - W4.0 x W4.0	2.388	1.913	9.975	7.923	2.300	0.925	###	###	###	###	309	245	198	164	138	117
	4 x 4 - W2.9 x W2.9	2.404	1.962	10.893	8.817	2.300	0.946	###	###	###	###	344	272	220	182	153	130
4.0"	4 x 4 - W4.0 x W4.0	2.388	1.913	14.709	11.631	2.300	1.001	###	###	###	###	###	359	291	240	202	172
	6 x 6 - W4.0 x W4.0	2.888	2.413	12.135	10.083	2.629	1.467	###	###	###	###	394	311	252	208	175	149
	4 x 4 - W2.9 x W2.9	2.904	2.462	13.242	11.166	2.629	1.500	###	###	###	###	###	345	279	231	194	165
	4 x 4 - W4.0 x W4.0	2.888	2.413	17.949	14.871	2.629	1.590	###	###	###	###	###	###	372	307	258	220
4.5"	4 x 4 - W2.9 x W2.9	3.404	2.962	15.591	13.515	2.958	2.225	###	###	###	###	###	###	338	279	235	200
	4 x 4 - W4.0 x W4.0	3.388	2.913	21.189	18.111	2.958	2.362	###	###	###	###	###	###	###	374	314	268
5.0"	4 x 4 - W4.0 x W4.0	3.888	3.413	24.429	21.351	3.286	3.336	###	###	###	###	###	###	###	###	371	316
5.5"	4 x 4 - W4.0 x W4.0	4.388	3.913	27.669	24.591	3.615	4.534	###	###	###	###	###	###	###	###	###	364
6.0"	4 x 4 - W4.0 x W4.0	4.888	4.413	30.909	27.831	3.944	5.977	###	###	###	###	###	###	###	###	###	###

Concrete slabs on UFX-36 form deck

UNIFORM UNFACTORED SERVICE LIVE LOADS, PSF																		
Slab	Mesh	+d	-d	+φM	-φM	φV	I _{av}	Spans, feet										
								3'6"	4'0"	4'6"	5'0"	5'6"	6'0"	6'6"	7'0"	7'6"	8'0"	
3.0"	6 x 6 - W2.0 x W2.0*	0.844	1.500	1.738	3.155	1.946	0.390	118	91	72	58	48	40					
	6 x 6 - W2.9 x W2.9	0.844	1.500	2.465	4.520	1.946	0.405	168	128	101	82	68	57					
3.5"	6 x 6 - W4.0 x W4.0	2.075	1.756	8.625	7.248	2.271	0.776	370	283	224	181	150	126	107	92			
	4 x 4 - W2.9 x W2.9	2.092	1.806	9.425	8.083	2.271	0.794	###	316	249	202	167	140	120	103			
4.0"	4 x 4 - W4.0 x W4.0	2.075	1.756	12.684	10.618	2.271	0.835	###	###	328	265	219	184	157	135			
	6 x 6 - W4.0 x W4.0	2.575	2.256	10.785	9.408	2.595	1.267	###	368	290	235	194	163	139	120	105	92	
	4 x 4 - W2.9 x W2.9	2.592	2.306	11.774	10.432	2.595	1.295	###	###	322	261	216	181	154	133	116	102	
	4 x 4 - W4.0 x W4.0	2.575	2.256	15.924	13.858	2.595	1.368	###	###	###	346	286	241	205	177	154	135	
4.5"	4 x 4 - W2.9 x W2.9	3.092	2.806	14.123	12.781	2.920	1.961	###	###	###	394	320	264	222	189	163	142	125
	4 x 4 - W4.0 x W4.0	3.075	2.756	19.164	17.098	2.920	2.077	###	###	###	###	353	297	253	218	190	167	
5.0"	4 x 4 - W4.0 x W4.0	3.575	3.256	22.404	20.338	3.244	2.982	###	###	###	###	###	###	353	301	259	226	199
5.5"	4 x 4 - W4.0 x W4.0	4.075	3.756	25.644	23.578	3.568	4.103	###	###	###	###	###	###	###	349	301	262	230
6.0"	4 x 4 - W4.0 x W4.0	4.575	4.256	28.884	26.818	3.893	5.463	###	###	###	###	###	###	###	397	342	298	262

Concrete slabs on UF2X form deck

UNIFORM UNFACTORED SERVICE LIVE LOADS, PSF																		
Slab	Mesh	+d	-d	+φM	-φM	φV	I _{av}	Spans, feet										
								4'6"	5'0"	5'6"	6'0"	6'6"	7'0"	7'6"	8'0"	8'6"	9'0"	
4.0"	6 x 6 - W2.0 x W2.0*	1.919	3.007	4.060	6.326	2.629	1.365	167	135	112	94	80	69	60	53			
	6 x 6 - W2.9 x W2.9	1.904	2.962	5.785	8.921	2.629	1.422	238	193	159	134	114	98	86	75			
4.5"	6 x 6 - W4.0 x W4.0	2.388	3.413	9.975	14.064	2.958	2.128	###	333	275	231	197	170	148	130	115	103	
	4 x 4 - W2.9 x W2.9	2.404	3.462	10.893	15.463	2.958	2.170	###	###	363	300	252	215	185	161	142	126	112
5.0"	4 x 4 - W4.0 x W4.0	2.388	3.413	14.709	20.588	2.958	2.291	###	###	###	340	290	250	218	192	170	151	
	6 x 6 - W4.0 x W4.0*	2.888	3.913	12.135	16.224	3.286	2.943	###	###	334	281	239	206	180	158	140	125	
	4 x 4 - W2.9 x W2.9	2.904	3.962	13.242	17.812	3.286	3.000	###	###	365	307	261	225	196	172	153	136	
	4 x 4 - W4.0 x W4.0	2.888	3.913	17.949	23.828	3.286	3.171	###	###	###	###	352	304	265	233	206	184	
5.5"	4 x 4 - W2.9 x W2.9*	3.404	4.462	15.591	20.161	3.615	4.020	###	###	###	350	298	257	224	197	174	156	
6.0"	4 x 4 - W4.0 x W4.0	3.388	4.413	21.189	27.068	3.615	4.253	###	###	###	###	###	345	301	264	234	209	
	4 x 4 - W4.0 x W4.0	3.888	4.913	24.429	30.308	3.944	5.557	###	###	###	###	###	###	387	337	296	262	234
6.5"	4 x 4 - W4.0 x W4.0	4.388	5.413	27.669	33.548	4.272	7.103	###	###	###	###	###	###	###	373	328	290	259
7.0"	4 x 4 - W4.0 x W4.0*	4.888	5.913	30.909	36.788	4.601	8.914	###	###	###	###	###	###	###	359	318	284	254

SLAB TABLES

Note:
f'c = 3 ksi

Concrete slabs on B-INV form deck

UNIFORM UNFACTORED SERVICE LIVE LOADS, PSF																		
Slab	Mesh	+d	-d	+φM	-φM	φV	I _{av}	Spans, feet										
								4'0"	4'6"	5'0"	5'6"	6'0"	6'6"	7'0"	7'6"	8'0"	8'6"	
3.5"	6 x 6 - W2.0 x W2.0*	1.919	2.507	4.060	5.280	2.348	1.039	206	163	132	109	92	78	67				
	6 x 6 - W2.9 x W2.9*	1.904	2.462	5.785	7.426	2.348	1.081	290	229	186	153	129	110	95				
4.0"	6 x 6 - W4.0 x W4.0	2.388	2.913	9.975	12.040	2.739	1.700	###	372	301	249	209	178	154	134	118		
	4 x 4 - W2.9 x W2.9	2.404	2.962	10.893	13.274	2.739	1.735	###	###	332	274	230	196	169	147	130		
4.5"	4 x 4 - W4.0 x W4.0	2.388	2.913	14.709	17.653	2.739	1.829	###	###	###	365	306	261	225	196	172		
	6 x 6 - W4.0 x W4.0*	2.888	3.413	12.135	14.200	3.143	2.441	###	###	355	293	247	210	181	158	139	123	
5.0"	4 x 4 - W2.9 x W2.9	2.904	3.462	13.242	15.623	3.143	2.488	###	###	391	323	271	231	199	174	153	135	
	4 x 4 - W4.0 x W4.0	2.888	3.413	17.949	20.893	3.143	2.630	###	###	###	###	363	309	266	232	204	181	
5.5"	4 x 4 - W2.9 x W2.9*	3.404	3.962	15.591	17.972	3.560	3.432	###	###	###	###	371	312	266	229	200	176	155
	4 x 4 - W4.0 x W4.0	3.388	3.913	21.189	24.133	3.560	3.630	###	###	###	###	###	357	308	268	236	209	
6.0"	4 x 4 - W4.0 x W4.0	3.888	4.413	24.429	27.373	3.992	4.850	###	###	###	###	###	###	###	349	304	267	237
6.5"	4 x 4 - W4.0 x W4.0	4.388	4.913	27.669	30.613	4.437	6.311	###	###	###	###	###	###	###	390	340	299	265
6.5"	4 x 4 - W4.0 x W4.0*	4.888	5.413	30.909	33.853	4.895	8.033	###	###	###	###	###	###	###	###	376	331	293

Concrete slabs on LF2X form deck

UNIFORM UNFACTORED SERVICE LIVE LOADS, PSF																	
Slab	Mesh	+d	-d	+φM	-φM	φV	I _{av}	Spans, feet									
								4'6"	5'0"	5'6"	6'0"	6'6"	7'0"	7'6"	8'0"	8'6"	9'0"
4.0"	6 x 6 - W2.0 x W2.0*	1.919	3.007	4.060	6.326	2.300	1.365	167	135	112	94	80	69	60	53		
	6 x 6 - W2.9 x W2.9*	1.904	2.962	5.785	8.921	2.300	1.422	238	193	159	134	114	98	86	75		
4.5"	6 x 6 - W4.0 x W4.0	2.388	3.413	9.975	14.064	2.680	2.128	###	333	275	231	197	170	148	130	115	103
	4 x 4 - W2.9 x W2.9	2.404	3.462	10.893	15.463	2.680	2.170	###	363	300	252	215	185	161	142	126	112
5.0"	4 x 4 - W4.0 x W4.0	2.388	3.413	14.709	20.588	2.680	2.291	###	###	###	340	290	250	218	192	170	151
	6 x 6 - W4.0 x W4.0*	2.888	3.913	12.135	16.224	3.081	2.943	###	###	334	281	239	206	180	158	140	125
5.5"	4 x 4 - W2.9 x W2.9	2.904	3.962	13.242	17.812	3.081	3.000	###	###	365	307	261	225	196	172	153	136
	4 x 4 - W4.0 x W4.0	2.888	3.913	17.949	23.828	3.081	3.171	###	###	###	###	352	304	265	233	206	184
6.0"	4 x 4 - W2.9 x W2.9*	3.404	4.462	15.591	20.161	3.502	4.020	###	###	###	350	298	257	224	197	174	156
	4 x 4 - W4.0 x W4.0	3.388	4.413	21.189	27.068	3.502	4.253	###	###	###	###	###	345	301	264	234	209
6.5"	4 x 4 - W4.0 x W4.0	3.888	4.913	24.429	30.308	3.944	5.557	###	###	###	###	###	387	337	296	262	234
7.0"	4 x 4 - W4.0 x W4.0	4.388	5.413	27.669	33.548	4.406	7.103	###	###	###	###	###	###	373	328	290	259
7.0"	4 x 4 - W4.0 x W4.0*	4.888	5.913	30.909	36.788	4.888	8.914	###	###	###	###	###	###	###	359	318	284

Concrete slabs on LF3X form deck

UNIFORM UNFACTORED SERVICE LIVE LOADS, PSF																	
Slab	Mesh	+d	-d	+φM	-φM	φV	I _{av}	Spans, feet									
								7'6"	8'0"	8'6"	9'0"	9'6"	10'0"	10'6"	11'0"	11'6"	12'0"
5.0"	6 x 6 - W4.0 x W4.0	1.888	3.913	7.815	16.224	2.739	2.827	116	102	90	80	72	65				
	4 x 4 - W2.9 x W2.9	1.904	3.962	8.544	17.812	2.739	2.877	127	111	99	88	79	71				
5.5"	4 x 4 - W4.0 x W4.0	1.888	3.913	11.469	23.828	2.739	3.023	170	149	132	118	106	96				
	4 x 4 - W2.9 x W2.9	2.404	4.462	10.893	20.161	3.088	3.829	161	142	126	112	101	91	82	75		
6.0"	4 x 4 - W4.0 x W4.0	2.388	4.413	14.709	27.068	3.088	4.029	218	192	170	151	136	123	111	101		
6.5"	4 x 4 - W4.0 x W4.0	2.888	4.913	17.949	30.308	3.451	5.235	266	234	207	185	166	150	136	124	113	104
7.0"	4 x 4 - W4.0 x W4.0	3.388	5.413	21.189	33.548	3.827	6.661	314	276	244	218	196	177	158	144	132	121
7.5"	4 x 4 - W4.0 x W4.0	3.888	5.913	24.429	36.788	4.217	8.328	362	318	282	251	226	204	174	158	145	133
8.0"	4 x 4 - W4.0 x W4.0*	4.388	6.413	27.669	40.028	4.621	10.259	###	360	319	285	255	231	189	172	158	145
8.0"	4 x 4 - W4.0 x W4.0*	4.888	6.913	30.909	43.268	5.039	12.473	###	###	357	318	285	258	204	186	170	156

Notes:

1. Refer to the maximum unshored span tables on page 84 to verify that the desired span is acceptable.
2. Tables are based on unshored conditions using galvanized deck. If shoring is required or if the deck is uncoated, refer to the design considerations section of the Form Deck General Information for additional requirements regarding load capacity. Tables provide middle of floor capacities. See the design tool on the Canam website for perimeter and other options.
3. Tables are based on 145 pcf concrete and a 3 or more span condition.
4. Slab, +d, and -d are in inches.
5. +φM and -φM are in kip inches (per foot of width) and apply to NW and LW structural concrete.
6. * means A_s does not meet ACI criterion. (.0018 A_c for temperature steel) See reinforcement properties on page 85.
7. I_{av} is the weighted average of the cracked and uncracked I in the positive and negative region and is based on the equation for E_c in ACI-08 318. [I_{av} = (I_c + I_{cr})/4 + (-I_c/2)] and is based on NW concrete.
8. φV is based on NW concrete. Multiply by 0.75 for LW concrete.
9. ### means the calculated live loads exceed the SDI maximum of 400 psf.
10. Blank cells indicate that the calculated live loads are less than 40 psf or the span-to-depth ratio exceeds 24.

SLAB TABLES

Maximum Span Table for Multispan Conditions

	Slab Depth	Canam Profile																
		UFS					UF1X				UFX				UF2X			
		28	26	24	22	20	26	24	22	20	26	24	22	20	24	22	20	18
Normal Weight Concrete (145 pcf)	2.50"	3'0"	3'8"	4'9"	5'1"	5'5"	5'1"	6'9"	7'8"	8'3"								
	3.00"	2'11"	3'6"	4'6"	4'9"	5'1"	4'10"	6'4"	7'2"	7'8"	5'11"	7'8"	8'8"	9'4"				
	3.50"	2'10"	3'4"	4'3"	4'6"	4'10"	4'7"	6'0"	6'9"	7'3"	5'7"	7'3"	8'2"	8'9"	9'9"	11'3"	11'7"	13'0"
	4.00"	2'9"	3'3"	4'0"	4'4"	4'7"	4'5"	5'9"	6'5"	6'11"	5'4"	6'10"	7'9"	8'4"	9'3"	10'7"	11'1"	12'5"
	4.50"	2'8"	3'1"	3'11"	4'2"	4'5"	4'3"	5'6"	6'2"	6'8"	5'1"	6'6"	7'5"	8'0"	8'9"	10'1"	10'6"	12'0"
	5.00"	2'7"	3'0"	3'8"	4'0"	4'3"	4'1"	5'3"	5'11"	6'5"	4'11"	6'3"	7'1"	7'8"	8'4"	9'7"	10'1"	11'7"
	5.50"	2'6"	2'11"	3'7"	3'10"	4'1"	3'11"	5'1"	5'9"	6'2"	4'9"	6'0"	6'10"	7'5"	8'0"	9'2"	9'9"	11'4"
	6.00"	2'5"	2'10"	3'6"	3'9"	4'0"	3'10"	4'11"	5'6"	6'0"	4'7"	5'10"	6'8"	7'2"	7'8"	8'10"	9'5"	10'11"
	6.50"	2'5"	2'9"	3'5"	3'8"	3'11"	3'9"	4'9"	5'4"	5'10"	4'5"	5'8"	6'5"	7'0"	7'4"	8'6"	9'1"	10'8"
7.00"	2'4"	2'9"	3'4"	3'6"	3'9"	3'7"	4'8"	5'3"	5'8"	4'4"	5'5"	6'3"	6'9"	7'1"	8'3"	8'10"	10'4"	
Light Weight Concrete (115 pcf)	2.50"	3'2"	3'10"	5'0"	5'6"	5'10"	5'4"	7'2"	8'3"	8'10"								
	3.00"	3'1"	3'8"	4'9"	5'2"	5'6"	5'1"	6'9"	7'8"	8'3"	6'3"	8'2"	9'4"	10'0"				
	3.50"	3'0"	3'6"	4'7"	4'10"	5'2"	4'10"	6'5"	7'3"	7'10"	5'11"	7'9"	8'9"	9'5"	10'6"	11'11"	12'3"	13'8"
	4.00"	2'10"	3'5"	4'4"	4'8"	4'11"	4'8"	6'2"	6'11"	7'5"	5'8"	7'4"	8'4"	9'0"	9'11"	11'5"	11'9"	13'1"
	4.50"	2'9"	3'4"	4'2"	4'5"	4'9"	4'6"	5'11"	6'7"	7'2"	5'6"	7'1"	7'11"	8'7"	9'6"	10'10"	11'4"	12'8"
	5.00"	2'9"	3'3"	4'0"	4'4"	4'7"	4'4"	5'8"	6'4"	6'10"	5'3"	6'9"	7'8"	8'3"	9'1"	10'5"	10'10"	12'3"
	5.50"	2'8"	3'2"	3'11"	4'2"	4'5"	4'3"	5'6"	6'2"	6'8"	5'1"	6'6"	7'5"	8'0"	8'8"	10'0"	10'6"	11'11"
	6.00"	2'7"	3'1"	3'9"	4'0"	4'4"	4'1"	5'4"	6'0"	6'5"	4'11"	6'4"	7'2"	7'9"	8'4"	9'7"	10'1"	11'8"
	6.50"	2'6"	3'0"	3'8"	3'11"	4'2"	4'0"	5'2"	5'9"	6'3"	4'9"	6'1"	6'11"	7'6"	8'1"	9'4"	9'10"	11'5"
7.00"	2'6"	2'11"	3'7"	3'10"	4'1"	3'11"	5'0"	5'8"	6'1"	4'8"	5'11"	6'9"	7'4"	7'10"	9'0"	9'6"	11'1"	

Notes:

- Spans are based on SDI construction loading and LRFD method.
- Quick selection table uses the lesser of the 2 or 3 span condition and truncates all span lengths down to the nearest inch.
- Blank cells indicate that the SDI 1 1/2" cover requirement is not met for the slab depth.
- Maximum unshored spans for B, Inverted B, N, LF2X, and LF3X are the same as for the B-Lok, Inverted B-Lok, N-Lok, 2" Lok Floor, and 3" Lok Floor. Refer to the maximum unshored span tables in the composite deck section.**
- Minimize time between deck installation and concrete placement or plank heavy traffic areas, especially for 28 and 26 gage product.

Form Deck Maximum Cantilevers

	Slab Depth	Canam Profile																
		UFS					UF1X				UFX				UF2X			
		28	26	24	22	20	26	24	22	20	26	24	22	20	24	22	20	18
Normal Weight Concrete (145 pcf + 5 pcf for rebar)	2.50"	9"	11"	1'2"	1'5"	1'8"	1'4"	1'10"	2'3"	2'8"								
	3.00"	8"	10"	1'1"	1'4"	1'7"	1'3"	1'9"	2'2"	2'7"	1'6"	2'1"	2'7"	3'2"				
	3.50"	8"	10"	1'1"	1'4"	1'6"	1'3"	1'8"	2'1"	2'5"	1'6"	2'0"	2'6"	3'0"	2'11"	3'7"	4'3"	5'5"
	4.00"	8"	10"	1'1"	1'3"	1'6"	1'2"	1'7"	2'0"	2'4"	1'5"	1'11"	2'4"	2'10"	2'9"	3'4"	4'0"	5'2"
	4.50"	8"	10"	1'0"	1'3"	1'5"	1'2"	1'7"	1'11"	2'3"	1'5"	1'10"	2'3"	2'9"	2'8"	3'3"	3'10"	4'10"
	5.00"	8"	9"	1'0"	1'2"	1'5"	1'2"	1'6"	1'10"	2'2"	1'4"	1'10"	2'2"	2'8"	2'6"	3'1"	3'8"	4'8"
	5.50"	8"	9"	1'0"	1'2"	1'4"	1'1"	1'6"	1'10"	2'1"	1'4"	1'9"	2'2"	2'6"	2'5"	3'0"	3'6"	4'5"
	6.00"	7"	9"	1'0"	1'2"	1'4"	1'1"	1'6"	1'9"	2'1"	1'4"	1'9"	2'1"	2'6"	2'4"	2'10"	3'5"	4'4"
	6.50"	7"	9"	1'0"	1'2"	1'4"	1'1"	1'5"	1'9"	2'0"	1'3"	1'8"	2'1"	2'5"	2'4"	2'10"	3'4"	4'2"
	7.00"	7"	9"	1'1"	1'1"	1'4"	1'1"	1'5"	1'9"	2'0"	1'3"	1'8"	2'0"	2'5"	2'3"	2'9"	3'3"	4'1"

Notes:

- This table is based on 145 pcf concrete with an additional 5 pcf to account for a significant amount of rebar at the cantilever.
- Table uses the SDI single span loading combinations and loading including a concentrated load at the end.
- Table is LRFD based. Factored resistance values are shown in the slab load tables.
- Cantilever deflection limits are: cantilever/90 and 3/4 inch.
- Web crippling considers 3 inch bearing for UFS, UF1X, and UFX and 5 inch bearing of UF2X. It also considers a backspan of two times the cantilever. SDI concentrated load is located over the beam.
- Blank cells indicate that the SDI 1 1/2" cover requirement is not met for the slab depth.
- Maximum cantilevers for N, LF2X, and LF3X are the same as for the N-Lok, 2" Lok Floor and 3" Lok Floor. Refer to the maximum cantilever table in the composite deck section. When B deck or Inverted B deck is used as a form, use the cantilever tables for B-Lok on page 60.**
- Fasten side laps at 12" on center maximum at the cantilever. Deck must be fastened at back spans before any construction loading is applied.**

FORM DECK MAX SPANS AND CANTILEVERS

Reinforcement Properties

Welded Wire Fabric used in this manual**					
Conventional (USA)	Metric (International)	Wire Area (A_s)		Wire Diameter	
		in ² /ft	mm ² /m	inches	mm
6 x 6 - W1.4 x W1.4	152 x 152 - MW9.1 x MW9.1	0.028	59.3	0.134	3.39
6 x 6 - W2.0 x W2.0	152 x 152 - MW12.9 x MW12.9	0.040	84.7	0.160	4.05
6 x 6 - W2.9 x W2.9	152 x 152 - MW18.7 x MW18.7	0.058	122.8	0.192	4.88
6 x 6 - W4.0 x W4.0	152 x 152 - MW25.8 x MW25.8	0.080	169.4	0.226	5.73
4 x 4 - W1.4 x W1.4	102 x 102 - MW9.1 x MW9.1	0.042	88.9	0.134	3.39
4 x 4 - W2.0 x W2.0	102 x 102 - MW12.9 x MW12.9	0.060	127.0	0.160	4.05
4 x 4 - W2.9 x W2.9	102 x 102 - MW18.7 x MW18.7	0.087	184.2	0.192	4.88
4 x 4 - W4.0 x W4.0	102 x 102 - MW25.8 x MW25.8	0.120	254.0	0.226	5.73

** Values taken from the Wire Reinforcement Institute Standard.

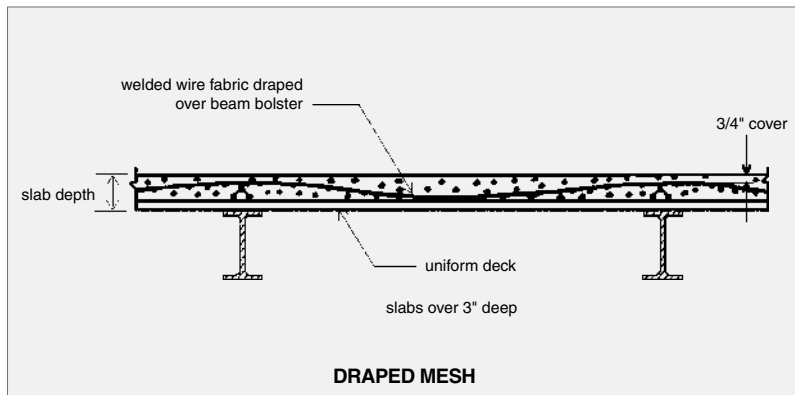

Bar No.	Dia.	Wt. (plf)	REBAR - Area of steel per foot of width				
			Spacing, inches				
			4	6	8	10	12
3	3/8"	0.38	.33	.22	.17	.13	.11
4	1/2"	0.67	.60	.40	.30	.24	.20
5	5/8"	1.04	.93	.62	.47	.37	.31
6	3/4"	1.50	1.32	.88	.66	.53	.44
7	7/8"	2.04	1.80	1.20	.90	.72	.60
8	1"	2.67	2.37	1.58	1.19	.95	.79
9	1 1/8"	3.40	3.00	2.00	1.50	1.20	1.00

ACI Coefficients

ACI Coefficients	THREE OR MORE SPANS					TWO SPANS			ONE SPAN				
	moment wl^3												
+ M	0.091	0.063	0.063	0.063	0.063	0.091	0.091	0.125					
- M	0.10	0.091	0.091	0.091	0.091	0.111							
	- M: SPANS 10' OR LESS												
- M	0.083	0.083	0.083	0.083	0.083	0.083							
shear wl	V	0.5	0.58	0.5	0.5	0.5	0.5	0.5	0.58	0.58	0.5	0.5	0.5

Notes:

- These coefficients should not be used where (a) the larger of two adjacent spans exceed the shorter by more than 20 percent; (b) slabs are not uniformly loaded; (c) the unit live load exceeds three times the unit dead load.
- The values to be used for clear span length (l) in determining negative moments should be the average of the two adjacent clear spans.
- For positive moments and for shears, the clear span of the particular span should be used.
- Most codes permit different coefficients for the negative moment for spans equal to or less than 10 feet.

SLAB AND REINFORCEMENT DATA



U.L. Design No	Concrete Cover and Type	Canam Product
D780	2 1/2" NW,LW	UFS,UFX
D903	3" NW, 2 3/4" LW	H6, H7.5, J, LS4.5, LS6, LS7.5 fluted; HC6, HC7.5, JC cellular
G205	2 1/2" NW	UFS, UF1X, UFX
G208	2" NW	UFS, UF1X, UFX
G255	2 1/2" NW	UFS
G256	2 1/2" NW	UFS, UF1X, UFX
G262	2 1/2" NW	UFS, UF1X, UFX (24 ga. min.)
G264	2 1/2" NW	UFS, UF1X, UFX
G501	2" NW	UFS
G531	2 3/16" NW	UFX (24 ga. min.)
G534	1 1/2" LW	UFS
G540	2" NW, LW	UFS, UF1X, UFX
G542	2" NW, LW	UFS, UF1X, UFX
G543	2" NW, LW	UFS, UF1X, UFX
G546	2" NW, LW	UFS, UF1X, UFX
G548	2 1/2" NW	UF1X (22 ga. min.)
G701	2 1/2" NW, LW	UFS
G703	3 1/8" NW, 2 3/8" LW	UFX
G705	2 1/2" NW, LW	UFS
G707	3 1/8" NW, 2 3/8" LW	UFX
G708	2 1/2" NW, LW	UFS
G709	2 1/2" NW, LW	UFS
G710	2 1/2" NW, LW	UFS
G801	2 1/2" NW, LW	UFS
G805	3 1/8" NW, 2 3/8" LW	UFX
D780	2 1/2" NW,LW	UFS,UFX
D903	3 1/2" NW, 3" LW	H6, H7.5, J, LS4.5, LS6, LS7.5 fluted; HC6, HC7.5, JC cellular
G203	2" NW	UFS
G204	2 1/2" NW	UFS
G205	2 1/2" NW	UFS, UF1X, UFX
G208	2" NW	UFS, UF1X, UFX
G211	2 1/2" NW	UFS, UFX (24 ga. min.)
G213	3" NW	UFS, B
G228	2 1/2" NW	UFS
G229	2" NW	UFS
G231	2 1/2" NW	UFS
G236	2 1/2" NW	UFS
G243	2" NW	UFS
G244	3" NW	UFS
G262	2 1/2" NW	UFS, UF1X, UFX (24 ga. min.)
G264	2 1/2" NW	UFS, UF1X, UFX
G267	2 1/2" NW	UFS, UF1X, UFX (24 ga. min.)
G268	2 1/2" NW	UFS
G502	2" NW	UFS
G508	2" NW	UFS
G509	2" NW	UFS
G530	2 1/2" NW, LW	UF1X (24 ga. min.)
G531	2 3/16" NW	UFX (24 ga. min.)
G701	2 1/2" NW, LW	UFS
G703	3 7/8" NW, 2 7/8" LW	UFX
G705	2 1/2" NW, LW	UFS
G707	3 7/8" NW, 2 7/8" LW	UFX
G708	2 1/2" NW, LW	UFS
G709	2 1/2" NW, LW	UFS
G801	2 1/2" NW, LW	UFS
G805	3 7/8" NW, 2 7/8" LW	UFX
D780	2 1/2" NW, LW	UFS,UFX
D903	4 1/4" NW, 3 1/2" LW	H6, H7.5, J, LS4.5, LS6, LS7.5 fluted; HC6, HC7.5, JC cellular
G008	2 1/2" NW	UFS
G023	2 1/4" NW	UFS
G028	2 1/2" NW	UFS
G031	2 1/2" NW	UFS, UF1X, UFX
G036	2 1/2" NW	UFS
G203	2 1/2" NW	UFS
G204	2 1/2" NW	UFS
G205	2 1/2" NW	UFS, UF1X, UFX
G208	2 1/2" NW	UFS, UF1X, UFX
G209	3" NW	UFS
G211	2 1/2" NW	UFS, UFX (24 ga. min.)
G213	3" NW	UFS, B
G227	2 1/2" NW	UFS
G228	2 1/2" NW	UFS
G229	2 1/2" NW	UFS
G231	2 1/2" NW	UFS
G236	2 1/2" NW	UFS
G243	2 1/2" NW	UFS
G244	3" NW	UFS
G250	2 1/2" NW	UFS
G255	2 1/2" NW	UFS
G256	2 1/2" NW	UFS, UF1X, UFX
G258	2 1/2" NW	UF1X, UFX
G268	2 1/2" NW	UFS

U.L. Design No	Concrete Cover and Type	Canam Product
G503	2 1/2" NW	UFS
G504	2 1/2" NW	UFS
G505	2" NW	UFS
G510	2 1/2" NW	UFS
G515	2 3/4" NW	UFS
G521	2 1/2" NW	UFS
G523	2 1/2" NW	UFS, BL
G529	2 1/2" NW, LW	UFS, BL
G530	2 1/2" NW, LW	UF1X (24 ga. min.)
G531	2 3/16" NW	UFX (24 ga. min.)
G531	2 1/2" LW	UFS
G533	2" LW	UFS
G538	2 1/2" NW	UFS
G540	2" NW, LW	UFS, UF1X, UFX
G542	2" NW, LW	UFS, UF1X, UFX
G545	2" NW, LW	UFS, UF1X, UFX
G546	2" NW, LW	UFS, UF1X, UFX
G547	2 1/2" NW	UFS, B, UF2X, LF2X, LF3X fluted or cellular
G554	2 7/16" NW, LW	UFX (24 ga. min.)
G701	2 1/2" NW, LW	UFS
G703	4 5/8" NW, 3 3/8" LW	UFX
G705	2 1/2" NW, LW	UFS
G707	4 5/8" NW, 3 3/8" LW	UFX
G708	2 1/2" NW, LW	UFS
G709	2 1/2" NW, LW	UFS
G710	2 1/2" NW, LW	UFS
G801	2 1/2" NW, LW	UFS
G805	4 5/8" NW, 3 3/8" LW	UFX
D753	2 3/4" NW, LW	UFS, UF1X, UFX
D776	2 3/4" NW, LW	UFS, UF1X, UFX
D780	2 1/2" NW, LW	UFS, UFX
D863	2 3/4" NW, LW	UFS, UF1X, UFX
D903	4" LW	H6, H7.5, J, LS4.5, LS6, LS7.5 fluted;
G033	3 1/2" NW	UFS, UF1X, UFX
G036	3 1/4" NW	UFS
G205	3" NW	UFS, UF1X, UFX
G211	3" NW	UFX (24 ga. min.)
G213	3 1/2" NW	UFS, B
G229	3 1/4" NW	UFS
G256	3 1/2" NW	UFS, UF1X, UFX
G268	2 5/8" NW	UFS
G512	2 1/2" NW	UFS
G523	3" NW	BL
G529	2 3/4" NW	UFS, BL
G547	3" NW	B, UF2X; LF2X, LF3X fluted or cellular
G701	2 3/4" NW, LW	UFS
G703	2 3/8" NW	UF2X, B, LF2X, LF3X (22 ga. min.)
G705	2 3/4" NW, LW	UFS
G707	2 3/8" NW	UF2X, B, LF2X, LF3X (22 ga. min.)
G708	2 3/4" NW, LW	UFS
G709	2 3/4" NW, LW	UFS
G710	2 3/4" NW, LW	UFS
G801	2 3/4" NW, LW	UFS
G805	2 3/8" NW	UF2X, B, LF2X, LF3X (22 ga. min.)
G401	2 1/2" NW	UFS

RESTRAINED ASSEMBLY RATINGS (HOURLY)

3

4

The table shows constructions that are normally used for floors. For roofs see U.L. Pxxx and page 23 of this manual. For composite floors see U.L. Dxxx and page 63 of this manual. In general, heavier and deeper form members may be used without compromising the fire rating; however, concrete cover must remain and any beam and joist spacing restrictions still apply. **In all cases the U.L. Fire Resistance Directory should be consulted for concrete densities, fastening requirements, and all details of construction.** Some ratings have the concrete cover vary with the span - particularly the 700 numbers. This table was prepared using the 2007 U.L. Fire Resistance Directory.

FIRE PROTECTION CODE	
U.L. #	
000-099	Concealed Grid
200-299	Exposed Grid
400-499	Suspended Plaster
500-599	Suspended Gypsum Board
700-799	Spray Applied Fire Resistive Material
800-899	

FIRE RATINGS

ANSI/SDI-NC1.0 Standard for Non-Composite Steel Floor Deck

1. General

1.1 Scope:

A. This Specification for Non-Composite Steel Floor Deck shall govern the materials, design, and erection of cold formed non-composite steel deck used as a form for reinforced concrete slabs.

Commentary: In the past, most of the steel decking used in the manner this specification covers was referred to as “centering,” however, various roof deck units have successfully been used as non-composite forms. This specification is intended to also include these applications.

B. Commentary shall not be considered part of the mandatory document.

1.2 Reference Codes, Standards and Documents:

A. Codes and Standards: For purposes of this standard, comply with applicable provisions of the following Codes and Standards:

1. American Iron and Steel Institute (AISI) Standard - *North American Specification for the Design of Cold-Formed Steel Structural Members*, 2001 Edition with Supplement 2004
2. American Welding Society - ANSI/AWS D1.3 Structural Welding Code/Sheet Steel - 98 Structural Welding Code - Sheet Steel
3. American Society for Testing and Materials (ASTM) A653 (A653M)-06, A924 (A924M)-06, A1008 (A1008M)-06

4. American Society of Civil Engineering (ASCE) -SEI/ASCE7-05

5. American Concrete Institute (ACI) Building Code Requirements for Reinforced Concrete – ACI 318-05

6. Underwriters Laboratories (UL) Fire Resistance Directory - <http://www.ul.com/database2006>

B. Reference Documents: Refer to the following documents:

1. SDI White Paper - Designing with Steel Form Deck-2003
2. SDI Manual of Construction with Steel Deck - MOC2-2006
3. SDI Standard Practice Details - SPD2-2001
4. SDI Diaphragm Design Manual - DDMO3-2004

2. Products

2.1 Material:

A. Sheet steel for galvanized deck shall conform to ASTM A653 (A653M) Structural Quality, with a minimum yield strength of 33 ksi (230 MPa).

B. Sheet steel for uncoated deck shall conform to ASTM A1008 (A1008M) with a minimum yield strength of 33 ksi (230 MPa). Other structural sheet steels or high strength low alloy steels are acceptable, and shall be selected from the *North American Specification for the Design of Cold-Formed Steel Structural Members*.

Commentary: Materials are offered in A653 (A653M) grade 80 steel (galvanized) or ASTM A1008 (A1008M) grade 80 steel (uncoated). This steel has

a minimum yield strength of 80 ksi (550 MPa) and is generally over 90 ksi (620 MPa). The AISI specifications allow a maximum allowable stress of 36 ksi (250 MPa) for this material.

C. Sheet steel for accessories shall conform to ASTM A653 (A653M) Structural Quality for structural accessories, ASTM A653 (A653M) Commercial Quality for non-structural accessories, or ASTM A1008 (A1008M) for either structural or non-structural accessories. Other structural sheet steels or high strength low alloy steels are acceptable, and shall be selected from the *North American Specification for the Design of Cold-Formed Steel Structural Members*.

D. The deck type profile and thickness (gage) shall be as shown on the plans.

2.2 Tolerance:

A. Uncoated thickness shall not be less than 95% of the design thickness as listed in Table 2.2.1:

Table 2.2.1

Gage No.	Design Thickness		Minimum Thickness	
	in.	mm.	in.	mm.
28	0.0149	0.38	0.014	0.35
26	0.0179	0.45	0.017	0.43
24	0.0238	0.60	0.023	0.57
22	0.0295	0.75	0.028	0.71
20	0.0358	0.91	0.034	0.86
18	0.0474	1.20	0.045	1.14
16	0.0598	1.52	0.057	1.44

B. Panel length shall be within plus or minus 1/2 inch (12 mm) of specified length.

C. Panel cover width shall be no greater than minus 3/8 inch (10 mm), plus 3/4 inch (20 mm).

ANSI/SDI-NC1.0 Standard for Non-Composite Steel Floor Deck

- D. Panel camber and/or sweep shall be no greater than 1/4 inch in 10 foot length (6 mm in 3 m).
- E. Panel end out of square shall not be greater than 1/8 inch per foot of panel width (10 mm per m).

2.3 Finish:

- A. Galvanizing shall conform to ASTM A924 (A924M) and/or ASTM A653 (A653M).
- B. Uncoated (black) shall conform to ASTM A1008 (A1008M).
- C. Painted with a shop coat of primer paint (one or both sides) shall be applied to steel sheet conforming to ASTM A1008 (A1008M).
- D. The finish on the steel non-composite floor deck shall be suitable for the environment of the structure.

Commentary: The uncoated finish is, by custom, referred to as "black" by some users and manufacturers; the use of the word "black" does not refer to paint color on the product. When galvanized material is used to support a reinforced concrete slab, the slab dead load is considered to be permanently carried by the deck. For any permanent load carrying function, a minimum galvanized coating conforming to ASTM A653 (A653M), G30 (Z090) is recommended.

2.4 Design:

- A. Deck used as a form for structural (reinforced) concrete slab:
 1. The section properties of the steel floor deck unit shall be computed in accordance with the *North American*

Specification for the Design of Cold-Formed Steel Structural Members.

2. Allowable Stress Design (ASD): Bending stress shall not exceed 0.60 times the yield strength, nor exceed 36 ksi (250 MPa) under the combined loads of wet concrete, deck weight, and the following construction live loads: 20 pounds per square foot (1 kPa) uniform load or 150 pound concentrated load on a 1'-0" (300 mm) wide section of deck (2.2 kN per m). The interaction of shear and bending shall be considered in the calculations. (See Figure 1 - Attachment NC1)
3. Load and Resistance Factor Design (LRFD): The load combination for construction are as shown in Attachment NC1. Load factors shall be in accordance with ASCE 7. (See Section 1.2.A.5) The resistance factors and nominal resistances shall be in accordance with the *North American Specification for the Design of Cold-Formed Steel Structural Members.*

Commentary: The loading shown in Figure 1, Attachment NC1 is representative of the sequential loading of wet concrete on the form. The 150 pound load (per foot of width) is the result of distributing a 300 pound man over a 2 foot (600 mm) width. Experience has shown this to be a conservative distribution. The metric equivalent of the 150 pound load is 2.2 kN per meter of width. For single span deck conditions, the ability to control

the concrete placement may be restricted and a factor of 1.5 is applied to the concrete load to address this condition; however, in order to keep this 50% load increase within a reasonable limit, the increase is not to exceed 30 psf (1.44 kPa). Whenever possible, the deck shall be multi-span and not require shoring during the concrete placement procedure.

4. Deck Deflection: Calculated deflections of the deck shall be based on the load of the wet concrete, as determined by the design slab thickness and the weight of the steel deck, uniformly loaded on all spans, and shall be limited to 1/180 of the clear span or 3/4 inch (20 mm), whichever is smaller. Calculated deflections shall be relative to supporting members.

Commentary: The deflection calculations do not take into account construction loads because these are considered temporary loads. The deck is designed to always be in the elastic range so removal of temporary loads should allow the deck to recover. The structural steel also deflects under the loading of the wet concrete.

The designer is urged to check the deflection of the total system, especially if composite beams and girders are being used. If the designer wants to include additional concrete loading on the deck because of frame deflection, the additional load should be shown on the design drawings or stated in the deck section of the job specifications.

2.4 Design:

5. Minimum Bearing: Minimum bearing lengths shall be determined in accordance with the web crippling provisions of the *North American Specification for the Design of Cold-Formed Steel Structural Members*; the uniform loading case of wet concrete, plus the weight of the steel deck, plus 20 psf (1 kPa) construction load shall be used.

Commentary: Experience has shown that 1-1/2 inches (38 mm) of bearing is sufficient for non-composite floor decks. If less than 1-1/2 inches (38 mm) of end bearing is available, or if high support reactions are expected, the design professional should check the deck web crippling capacity. The deck must be adequately attached to the structure to prevent slip off.

6. Diaphragm Shear Capacity: Diaphragms without concrete shall be designed in accordance with the SDI *Diaphragm Design Manual*, or from tests conducted by an independent professional engineer.

Commentary: Calculations of diaphragm strength and stiffness should be made using the SDI *Diaphragm Design Manual*. If testing is used as the means for determining the diaphragm strength and stiffness, then it should follow the AISI TS 7-02 test protocol.

B. Concrete Slab Design:

1. General: The design of the concrete slabs shall be done in

accordance with the ACI *Building Code Requirements for Reinforced Concrete*. The minimum concrete thickness above the top of the deck shall be 1-1/2 inches (38 mm). Randomly distributed fibers or fibrous admixtures shall not be substituted for welded wire fabric tensile reinforcement.

Commentary: In following the ACI requirements for temperature reinforcement, the designer may eliminate the concrete area that is displaced by the deck ribs. For slabs with total depth of 3 inches (75 mm) or less, the reinforcing mesh may be considered to be at the center of the concrete above the deck. (Refer to the SDI *Designing with Steel Form Deck* for slab design information) If uncoated or painted deck is used as the form, the load from concrete slab weight must be deducted from the calculated capacity of the reinforced concrete slab. If galvanized form is used, the load from the slab weight is considered to be permanently carried by the deck and need not be deducted from the live load. If temporary shoring is used, the load of the slab must be deducted from the calculated capacity of the reinforced slab, regardless of the deck finish. Except for some diaphragm values, the deck should not be assumed to act compositely with the concrete even though strong chemical bonds can, and do, develop.

2. Concrete: Concrete design shall be in accordance with the applicable sections of the ACI *Building Code Requirements for Reinforced*

Concrete. Minimum compressive strength ($f'c$) shall be 3 ksi (20 MPa) or as required for fire ratings or durability. Admixtures containing chloride salts shall not be used.

Commentary: The use of admixtures containing chloride salts is not allowed because the salts will corrode the steel non-composite floor deck.

3. Cantilever Loads: When cantilevered slabs are encountered, top reinforcing steel shall be proportioned by the designer. For construction loads, the deck shall be designed for the more severe of (a) deck plus slab weight plus 20 psf (1 kPa) construction load on both cantilever and adjacent span, or (b) deck plus slab weight on both cantilever and adjacent span plus a 150 pound (665N) concentrated load per foot of width at end of cantilever. The load factors shall be in accordance with ASCE7. Resistance factors for bending, shear, and interior bearing shall be by the *North American Specification for the Design of Cold-Formed Steel Structural Members*.

The maximum cantilever deflection as a form, under deck plus slab weight, shall be $a/90$ where "a" is the clear cantilever length, and shall not exceed 3/4 inch (19 mm).

Side laps shall be attached at the end of the cantilever and a maximum spacing of 12 inches (300 mm) on center from cantilever end. Each corrugation shall be fastened

ANSI/SDI-NC1.0 Standard for Non-Composite Steel Floor Deck

at both the perimeter support and the first interior support. The deck shall be completely attached to the supports and at the side laps before any load is applied to the cantilever. Concrete shall not be placed on the cantilever until after placement on the adjacent span.

2.5 Accessories:

- A. Pour stops, column closures, end closures, cover plates, and girder fillers shall be the type suitable for the application. Pour stop minimum gages shall be in accordance with the Steel Deck Institute. (See *Pour Stop Selection Table*, Attachment NC2)
- B. Mechanical fasteners or welds shall be permitted for deck and accessory attachment.

3. Execution

3.1 Installation/General:

- A. Support framing and field conditions shall be examined for compliance with requirements for installation tolerances and other conditions affecting performance of work of this section. All OSHA rules for erection shall be followed.
- B. Deck panels shall be installed on a concrete support structure only after concrete has attained 75% of its specified design strength.
- C. Deck panels and accessories shall be installed according to the *SDI Manual of Construction with Steel Deck*, placement plans, and requirements of this Section.
- D. Temporary shoring, if required, shall be installed before placing deck panels. Temporary shoring

shall be designed to resist a minimum uniform load of 50 psf (2.4 kPa), and loading indicated on Attachment NC1. Shoring shall be securely in place before the floor deck erection begins. The shoring shall be designed and installed in accordance with the *ACI Building Code Requirements for Reinforced Concrete*, and shall be left in place until the slab attains 75% of its specified design strength and a minimum of seven (7) days.

- E. Deck panels shall be placed on structural supports and adjusted to final position with ends aligned, and attached securely to the supports immediately after placement in order to form a safe working platform. All deck sheets shall have adequate bearing and fastening to all supports to prevent slip off during construction. Deck ends over supports shall be installed with a minimum end bearing of 1-1/2 inches (38 mm). Deck areas subject to heavy or repeated traffic, concentrated loads, impact loads, wheel loads, etc. shall be adequately protected by planking or other approved means to avoid overloading and/or damage.

Commentary: Staggering deck ends is not a recommended practice. The deck capacity as a form and the load capacity of a non-composite deck/slab system are not increased by staggering end joints, yet layout and erection costs are increased.

- F. Lapped or Butted Ends: Deck ends shall be either lapped or butted over supports. Gaps up to 1 inch (25 mm) shall be permitted at butted ends.

- G. Deck units and accessories shall be cut and neatly fit around openings and other work projecting through or adjacent to the decking.

Commentary: It is the responsibility of the designer to designate holes/openings to be decked over in compliance with applicable federal and state OSHA directives. Care should be taken to analyze spans between supports at openings when determining those holes/openings to be decked over.

When a framed opening span exceeds the maximum deck span limits for construction loads, the opening must be detailed around instead of decked over. (Minimum construction load 50 lbs./sq. ft. (2.4 kPa), unless specific requirements dictate otherwise). When a framed hole/opening in floor deck is shown and dimensioned on the structural design drawings, pour stop (screed) angle is required to top of slab. When specified, cell closure angles will be provided at the open ends of deck 1-1/2 inches (38 mm) deep or deeper, in standard 10 feet (3 m) lengths to be field sized, cut and installed. Typically, non-composite floor decks that are less than 1-1/2 inches (38 mm) deep do not require or use cell closure. Alternate means to dam concrete may be used in lieu of cell closure, at the discretion of the installer, if approved by the project engineer.

3.1 Installation/General:

When a hole/opening is not shown and dimensioned on the structural design drawings, no provisions for concrete retainage will be provided by the metal deck manufacturer/ supplier. Metal floor decking holes and openings to be cut after the concrete pour shall not be field cut until concrete has reached 75% of its design strength and a minimum seven (7) days.

- H. Trades that subsequently cut unscheduled openings through the deck shall be responsible for reinforcing these openings based upon an approved engineered design.

3.2 Installation/Anchorage:

- A. Form deck units shall be anchored to steel supporting members including perimeter support steel and/or bearing walls by arc spot puddle welds of the following diameter and spacing, fillet welds of equal strength, or mechanical fasteners.

1. All welding of deck shall be in accordance with ANSI/AWS D1.3, *Structural Welding Code - Sheet Steel*. Each welder shall demonstrate an ability to produce satisfactory welds using a procedure such as shown in the SDI *Manual of Construction with Steel Deck*, or as described in ANSI/AWS D1.3.
2. Welding washers shall be used on all deck units with metal thickness less than 0.028 inches (0.7 mm). Welding washers shall be a minimum thickness of 0.0598 inches (16 gage, 1.50 mm) and have a nominal 3/8 inch (10 mm) diameter hole.

3. Where welding washers are not used, a minimum visible 5/8 inch (15 mm) diameter arc puddle weld shall be used. Weld metal shall penetrate all layers of deck material at end laps and shall have good fusion to the supporting members.
4. Weld spacing: Fastening pattern shall allow slabs to be designed on a continuous basis.
5. When used, fillet welds shall be at least 1-1/2 inch (38 mm) long.
6. Mechanical fasteners, either powder actuated, pneumatically driven, or screws, shall be permitted in lieu of welding to fasten deck to supporting framing if fasteners meet all project service requirements. When the fasteners are powder actuated or pneumatically driven, the load value per fastener used to determine the maximum fastener spacing shall be based on a minimum structural support thickness of not less than 1/8 inch (3 mm) and on the fastener providing a minimum 5/16 inch (8 mm) diameter bearing surface (fastener head size). When the structural support thickness is less than 1/8 inch (3 mm), powder actuated or pneumatically driven fasteners shall not be used, but screws are acceptable.

Commentary: Mechanical fasteners (powder actuated, screws, pneumatically driven fasteners, etc.) are recognized as viable anchoring methods, provided the type and spacing of the fastener satisfies the design criteria. Documentation in the form of test data, design

calculations, or design charts should be submitted by the fastener manufacturer as the basis for obtaining approval.

7. For deck units with spans greater than five feet (1.5 m), side laps and perimeter edges of units between span supports shall be fastened at intervals not exceeding 36 inches (1 m) on center, using one of the following methods:
 - a. #10 self drilling screws.
 - b. Crimp or button punch.
 - c. Arc puddle welds 5/8 inch (15 mm) minimum visible diameter, or minimum 1 inch (25 mm) long fillet weld.

Commentary: The above side lap spacing is a minimum. Service loads or diaphragm design may require closer spacing or larger side lap welds. Good metal to metal contact is necessary for a good side lap weld. Burn holes are to be expected.

- B. Accessory Attachment:

1. Pour Stop and Girder Fillers: Pour stops and girder fillers shall be fastened to supporting structure in accordance with the SDI *Standard Practice Details, and Attachment NC2*.
2. Floor Deck Closures: Column closures, cell closures, and Z closures shall be fastened to provide tight fitting closures at open ends of ribs and sides of decking. Fasten cell closures at changes of direction of floor deck units unless otherwise directed.

Commentary: Cell closures are generally not used on form deck of 1-5/16 inch (33 mm) depth or less.

Introduction

Diaphragm load tables are provided to assist designers. An example illustrates the use of the tables. The tables are based on the SDI Diaphragm Design Manual 3rd Edition and present appropriate safety (Ω) and resistance (ϕ) factors for the various limit states. The factors depend on the load type. Nominal unit shear capacity (S_n) is presented and interpolation is acceptable. The lowest factored S_n controls design – connections normally control. Typical support fastener patterns are included. The tables fall into two categories – without concrete fill and with fill. For concrete structural slabs or insulation fills, the tables present the least cover thickness allowed by the analytical SDI method. The thickness exception is structural concrete where 2 in. cover is allowed but 2½ in. is presented at composite decks to be consistent with the slab tables. 2 in. structural concrete cover is shown over form deck. 2½ in. light weight fill is shown over form deck for classified insulation – consult the insulation concrete manufacturer for proprietary tables. Two types of generic insulation fills are provided: the first is a homogenous concrete matrix and the second embeds a layer of polystyrene insulation boards in the concrete. The boards have holes. For structural concrete, $f'c = 3$ ksi; for generic fills, $f'c = 125$ psi. The tables use the fastener strength associated with the minimum yield/tensile strength at each product (see page 160). The tables do not cover all possibilities. For thicker or stronger concrete or alternate fastener patterns, contact Canam Engineering. The SDI method limits the useful structural concrete cover to 6 in. Additional examples, tables and theory are presented in the SDI diaphragm publication and Canam recommends that this be purchased from SDI.

The tables provide the resistance and stiffness of the diaphragm field and are based on a 3 span condition. The strength of a diaphragm depends on: the mechanical properties and thickness of the steel, the fastener type, spacing, and combination, the deck span and cover width, and in rare cases on the deck profile. When fills are present, additional factors are the concrete type, compressive strength and cover. In general greater strength is possible with thicker deck, more fasteners, and more concrete cover or compressive strength. Stiffness depends on the same variables with greater profile impact in the no fill case. Diaphragm performance greatly depends on perimeter details to transfer shear into and out of the diaphragm and also on diaphragm continuity. These are design issues and the designer should provide perimeter details on the contract drawings. Since the concrete does most of the work, studs may be required to collect and transfer shear from the concrete to shear walls. Designers must indicate shear transfer points such as shear walls and rigid or braced frames. The deck bottom flat should land over parallel supports at these points to allow proper connection. When split panels are required at these terminations or in high shear areas, double the number of support fasteners or analyze the narrower cover sheet for suitability. Performance can be compromised by improper installation. AWS D1.1 addresses proper stud installation, AWS D1.3 addresses proper welding of deck, and the SDI Manual of Construction provides general installation information.

The “no fill” tables present combinations of welds and screws at the support and side-laps. The shear capacities of all welds are based on a minimum E60XX electrode. Other fasteners are possible and several power actuated fasteners are classified in

the SDI publication. Proprietary tables are test based and can be provided by the fastener manufacturer. Welded side-laps are possible at gages greater than and including 22 gage. Because of the difficulty, industry recommends that side-lap welds be avoided at 22 gage and less thickness. Blow holes are probable at most thicknesses and good weld performance depends on fusion at the perimeter. Weld washers are required over supports at thicknesses less than 22 gage. Selection of fasteners and spacing may depend on other service conditions, e.g. fire rating, insurance, walk-ability, and cosmetics. When button punched side-laps are chosen, it is acceptable to read the 0 side-lap fastener row in the tables and to neglect the button punch contribution. The minimum recommended spacing still applies.

When diaphragm shear is caused by a wind event, interaction is probable at the support fasteners. The tables present the full (unreduced) S_n . A design tool is available on the Canam web site to consider the interaction reduction at roof deck. Supports must be sufficiently thick so bearing of the deck against the fastener controls the fastener shear capacity. A minimum thickness of 1/8 in. is recommended for power actuated fasteners. Tilting of screws must be checked when light gage framing is used as supports and the framing is not significantly thicker than the deck. The SDI method applies but the tables must be adjusted for reduced support fastener shear capacity -- contact Canam Engineering.

Shear and Tension interaction equations for support fasteners:

WELDS:

ASD 

$$\left(\frac{Q_{f \text{ useable}}}{Q_{f \text{ no uplift}}} \right)^{1.5} + \left(\frac{\Omega_u T}{T_n} \right)^{1.5} = 1$$

LRFD 

$$\left(\frac{Q_{f \text{ useable}}}{Q_{f \text{ no uplift}}} \right)^{1.5} + \left(\frac{T_u}{\phi_u T_n} \right)^{1.5} = 1$$

It is acceptable to neglect interaction when the tension component is < 0.15 .

Where:

- T = required tensile strength at service load
- T_n = fastener nominal tensile (uplift) strength in the absence of shear.
- T_u = required tensile strength at factored service load (e.g. = 1.6T)
- Ω_u = safety factor for weld in tension = 2.5
- ϕ_u = resistance factor for weld in tension = 0.6
- $Q_{f \text{ useable}}$ = fastener nominal shear strength in the presence of an uplift force.
- $Q_{f \text{ no uplift}}$ = fastener nominal shear strength in the absence of an uplift force.

SCREWS:

ASD 

$$0.85 \left(\frac{Q_{f \text{ useable}}}{Q_{f \text{ no uplift}}} \right) + \left(\frac{\Omega_u T}{T_n} \right) = 1$$

LRFD 

$$0.85 \left(\frac{Q_{f \text{ useable}}}{Q_{f \text{ no uplift}}} \right) + \left(\frac{T_u}{\phi_u T_n} \right) = 1$$

It is acceptable to neglect interaction when the tension component is ≤ 0.15 .

Where:

- Ω_u = safety factor for screw in tension = 3.0
- ϕ_u = resistance factor for screw in tension = 0.5

INTRODUCTION

Example Problem

Diaphragm design example to illustrate the use of the Tables.

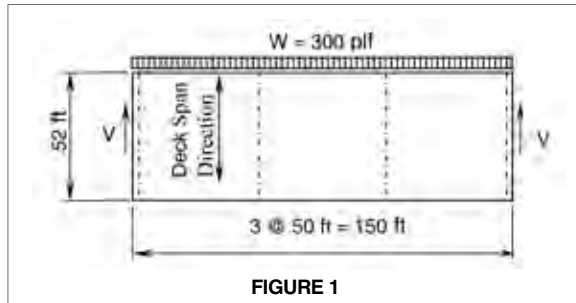

FIGURE 1

Problem: Shear is caused by wind.
Interior frames do not resist shear.
Deck: 20 gage B Deck on 5' 9½" span. A1008 SS 40
 $W_{DL} = 15$ psf. $W_{UL} = 30$ psf.
Wind uplift = 50 psf at corners.
Use ASD method. Safety Factor (Ω) = 2.35
Since uplift exists, weld shear and tension interaction exists.

Check flexural and uplift capacity using the tables on pages 6 & 8 at 6° 0". Results = OK.

Check Diaphragm:

$$V = 300 \times 150 / 2 = 22500 \text{ lb (Total shear reaction at side walls)}$$

$$v = 22500 / 52 = 433 \text{ plf (Unit shear at side walls)}$$

$$S_n \text{ Required} \geq 2.35 \times 433 = 1018 \text{ plf}$$

Try 5/8 diameter welds on 36/7 pattern with two #10 side lap screws per span.

From Table: With no allowance for uplift shear interaction,
Span = 5.5 ft, $S_n = 1137$ plf
Span = 6.0 ft, $S_n = 1038$ plf
Span = 5.78 ft, $S_n = 1137 - (1137 - 1038)(.28/.5) = 1082$ plf
Span = 5.78 ft, $S_{re} = 2444 - (2444 - 2054)(.28/.5) = 2226$ plf,
 $S_{re} / \Omega_2 > S_n / \Omega$. Results: Deck buckling will not control
 $Q_f = 2413$ lb (nominal shear capacity of weld)
 $K_1 = .340$ $K_2 = 1056$ $K_4 = 3.78$ $D_{33} = 97$

Check Interaction of Uplift and Shear (See load combinations and example on page 18.):

$$\text{Uplift } T \text{ required} = 5.78 \times (50 - 0.6 \times 15) \times 1.1 = 261 \text{ plf}$$

$$\text{Weld group nominal } T_{rn} = (1750 \times 5.7 / 3) = 3325 \text{ plf} \quad (\Omega_2 = 2.5)$$

Available shear per weld at supports, solve using interaction equation:

$$\left(\frac{Q_f}{Q_f \text{ available}} \right)^{1.5} + \left(\frac{\Omega_2 T}{T_{rn}} \right)^{1.5} = 1$$

$$Q_f \text{ available} = (1 - (2.5 \times 261 / 3325)^{1.5})^{0.67} \times 2413 = 2271 \text{ lbs}$$

Note: Equations for other fasteners are in the Diaphragm Introduction.

Approximate S_n available = $1082 \times (2271 / 2413) = 1018$ plf;
OK = S_n Required

Using the Canam web based design tool, $S_n = 1018$ plf and is in good agreement with the approximation. Approximation works well when the side-lap contribution is minimal.

Determine Stiffness:

$$G' = \frac{K_2}{K_4 + \frac{0.3D_{33}}{L_{33}} + 3K_1L_{33}} = \frac{1056}{3.78 + \frac{0.3 \times 97}{5.78} + 3 \times .340 \times 5.78} = 72 \text{ k/in}$$

Determine diaphragm deflection: Primarily a shear deflection problem -- Change in deflection between two points is the area under the V/G'B diagram. In this case:

$$\delta = \frac{wl^2}{8G'B} = \frac{Vl}{4G'B} = \frac{vl}{4G'} = \frac{433 \times 150}{4 \times 72 \times 1000} = .23 \text{ in} \quad \text{Compare with drift acceptance criterion.}$$

Perimeter edge details must be designed to transfer the forces. Determine the minimum spacing parallel with deck span along the 52 ft wall -- Welds must be possible at this condition (if not, designer should add a collector):

$$\text{Spacing} = Q_f / S_n = 2413 / 1018 = 2.37 \text{ ft/weld. Use } 1/3 \text{ points between beams.}$$

This conforms to the "rule of thumb" -- match the side lap spacing.

Depending on the detail transferring the 300 plf load into the diaphragm, additional forces are possible in the perimeter welds along the 150 ft wall. At the most, the component parallel with the deck span will be $300/2 = 150$ lbs per weld. The resultant shear of the diaphragm forces and this force will be compared with the allowable value per weld = $2413/2.35 = 1027$ lb. (See Figure 2) To avoid this analysis, additional welds may be specified. The axial capacity of the deck should also be checked at the exterior span. The eccentric load through the welds will add bending in the deck.

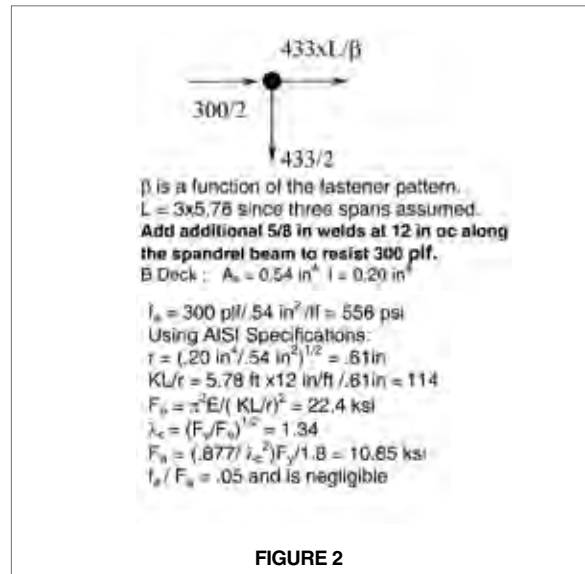

FIGURE 2

DESIGN EXAMPLE



Patterns

1½" B, F, B-LOK

36/7

36/5

36/4

30/6

30/4

30/3

3" N, N-LOK

24/4

1½" LOK FLOOR

24/3

2" LOK FLOOR, LF2X

36/4

3" LOK FLOOR, LF3X

36/4

9/16" UFS

35/4

UF1X

27/3

UFX

36/4

UF2X

30/3

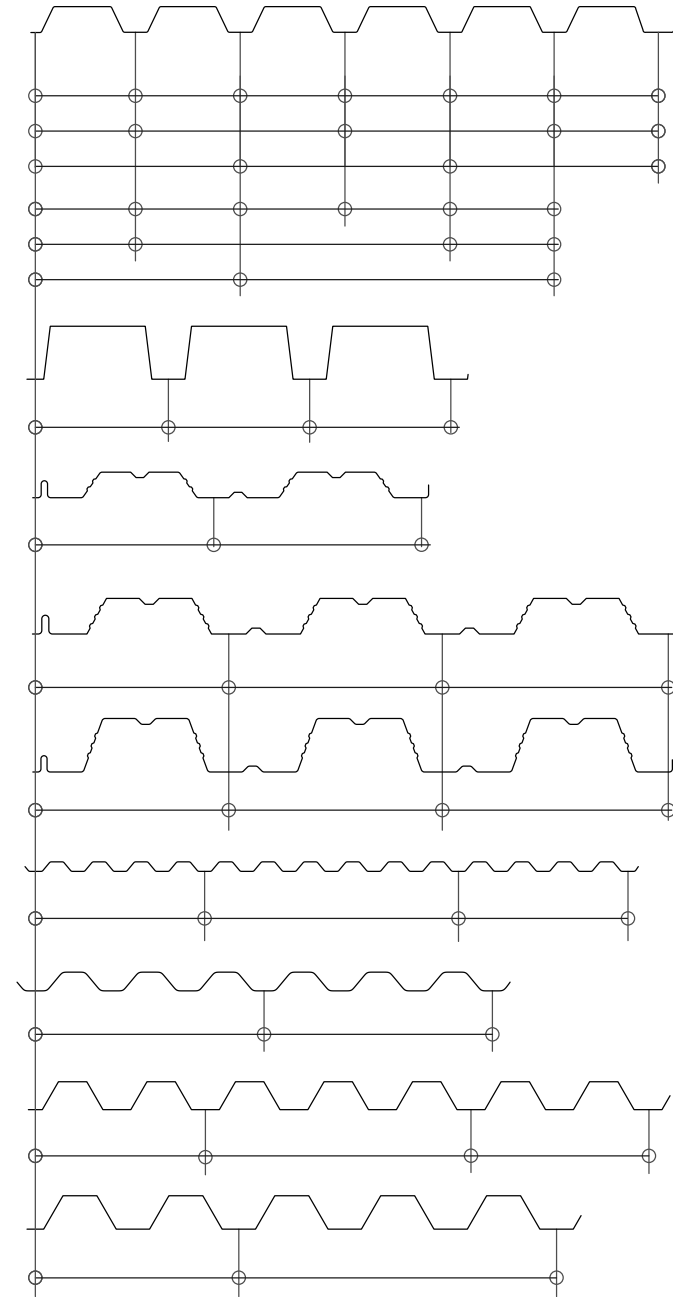

When either a horizontal foot is not present in the profile or the detail is shown on the erection drawings, weld either side of the interlocking side lap. An elongated seam weld of equal perimeter may be substituted for a puddle weld.



TYPICAL FASTENER LAYOUT



ROOF DECK - Weld Weld

B, F Deck 22 gage Diaphragm Tables $F_y = 40$ ksi

Fastener Support 5/8" ϕ puddle welds
Side-Lap 5/8" ϕ puddle welds or 1 1/2" fillet weld

Strength/Fast.
 $Q_t = 2010$ lb.
 $Q_s = 1507$ lb.

Load	Ω	ϕ
Seismic	3.00	0.55
Wind	2.35	0.70
Other	2.65	0.60

Canam does not recommend welded side laps for 22 gage.

Nominal Shear Strength (S_n), PLF

Fastener Pattern	Side-Lap Conn./Span	Span (L_v), Ft.								K1	
		3.0	3.5	4.0	4.5	5.0	5.5	6.0	6.5		7.0
36/7 Dxx* B = 129 F = 226	0	1314	1142	994	878	785	709	646	593	547	0.486
	1	1712	1504	1338	1204	1087	983	897	825	762	0.287
	2	2057	1828	1640	1484	1353	1242	1147	1056	978	0.204
	3	2350	2113	1911	1741	1595	1471	1363	1269	1186	0.158
	4	2596	2359	2153	1974	1819	1684	1566	1462	1370	0.129
	5	2800	2571	2366	2184	2023	1881	1755	1643	1544	0.109
	6	2969	2752	2552	2371	2208	2062	1931	1814	1709	0.094
	7	3109	2906	2714	2537	2375	2228	2094	1973	1863	0.083
	8	3226	3037	2855	2684	2525	2378	2244	2121	2008	0.074
	9	3324	3149	2978	2814	2660	2515	2381	2257	2143	0.067
10	3406	3245	3084	2929	2780	2639	2507	2384	2269	0.061	
36/5 Dxx* B = 758 F = 886	0	1162	1022	910	811	725	655	596	547	504	0.583
	1	1490	1333	1201	1091	998	918	847	778	719	0.319
	2	1743	1585	1448	1328	1225	1134	1055	985	923	0.219
	3	1935	1787	1652	1530	1422	1326	1240	1163	1094	0.167
	4	2080	1945	1818	1700	1592	1494	1405	1324	1251	0.135
	5	2190	2069	1952	1841	1737	1640	1550	1468	1392	0.113
	6	2274	2168	2062	1958	1859	1766	1678	1596	1519	0.098
	7	2340	2246	2150	2055	1963	1874	1789	1709	1633	0.086
	8	2392	2309	2223	2136	2050	1967	1886	1808	1734	0.076
	9	2433	2359	2282	2203	2124	2046	1970	1895	1824	0.069
10	2466	2401	2332	2260	2187	2115	2043	1972	1904	0.063	
36/4 Dxx* B = 1072 F = 1216	0	890	784	696	613	547	493	448	410	377	0.729
	1	1200	1081	979	893	819	756	699	642	592	0.358
	2	1417	1304	1201	1110	1030	958	895	838	788	0.237
	3	1566	1466	1371	1283	1202	1129	1062	1001	946	0.177
	4	1670	1584	1500	1418	1342	1270	1203	1141	1084	0.142
	5	1743	1670	1597	1524	1453	1385	1321	1260	1203	0.118
	6	1796	1735	1671	1606	1542	1479	1419	1361	1306	0.101
	7	1836	1783	1728	1671	1613	1556	1500	1446	1393	0.088
	8	1865	1820	1772	1722	1671	1619	1568	1517	1468	0.078
	9	1888	1849	1808	1763	1718	1671	1624	1577	1531	0.071
10	1906	1873	1836	1797	1756	1714	1671	1628	1585	0.064	

Shaded Area does not conform to SDI maximum fastener spacing of 36" o.c. for spans greater than 5' 0".

* D_{xx} is a warping factor dependent on the end fastener pattern and used in the equation for G' .

Values to the right of bold line may exceed the maximum recommended spans.

Deck Profile	Nominal Shear Strength due to Panel Buckling (S_{nb}), PLF								$\Omega_b = 2, \phi_b = .8$
	3.0	3.5	4.0	4.5	5.0	5.5	6.0	6.5	7.0
F22	5161	3792	2903	2294	1858	1536	1290	1099	948
B22	6011	4416	3381	2671	2164	1788	1503	1280	1104

$$G' = \frac{K_2}{K_4 + 0.3D_{xx}/L_v + 3K_1L_v} \text{ (kips/in)}$$

B & F Deck
 $K_2 = 870$
 $K_4 = 3.78$

Design Notes:

Choose more severe factored resistance:

LRFD lesser of $\phi_b S_{nb}$ and ϕS_n

ASD lesser of S_{nb}/Ω_b and S_n/Ω

If load = wind, see interaction calculator on web.



ROOF DECK - Weld Weld

F Deck 22 gage Diaphragm Tables $F_y = 40$ ksi

Fastener Support 5/8" ϕ puddle welds
Side-Lap 5/8" ϕ puddle welds or 1 1/2" fillet weld

Strength/Fast.
 $Q_t = 2010$ lb.
 $Q_s = 1507$ lb.

Load	Ω	ϕ
Seismic	3.00	0.55
Wind	2.35	0.70
Other	2.65	0.60

Canam does not recommend welded side laps for 22 gage.

Nominal Shear Strength (S_n), PLF

Fastener Pattern	Side-Lap Conn./Span	Span (L_v), Ft.										K1
		3.0	3.5	4.0	4.5	5.0	5.5	6.0	6.5	7.0		
30/6 Dxx* F = 226	0	1194	1023	889	785	702	633	576	528	487	0.647	
	1	1607	1407	1250	1120	1003	907	828	760	702	0.366	
	2	1967	1742	1559	1408	1282	1176	1079	992	918	0.256	
	3	2274	2038	1839	1672	1530	1409	1304	1213	1133	0.196	
	4	2532	2294	2089	1912	1759	1626	1511	1409	1320	0.159	
	5	2747	2515	2310	2128	1968	1828	1704	1594	1497	0.134	
	6	2925	2704	2503	2321	2159	2013	1884	1768	1664	0.116	
	7	3073	2866	2672	2493	2331	2183	2050	1930	1821	0.102	
	8	3196	3003	2818	2645	2485	2338	2204	2081	1969	0.091	
	9	3298	3120	2946	2780	2624	2479	2344	2221	2107	0.082	
10	3385	3220	3056	2898	2748	2606	2473	2350	2235	0.075		
30/4 Dxx* F = 1547	0	1085	956	852	761	680	614	559	512	472	0.728	
	1	1399	1256	1136	1034	947	873	809	744	687	0.391	
	2	1633	1494	1370	1261	1166	1082	1008	943	885	0.267	
	3	1805	1677	1558	1450	1352	1264	1185	1114	1050	0.203	
	4	1931	1817	1708	1605	1509	1421	1340	1266	1199	0.164	
	5	2025	1925	1826	1730	1640	1554	1475	1400	1332	0.137	
	6	2095	2008	1920	1833	1748	1667	1590	1517	1449	0.118	
	7	2149	2073	1995	1916	1838	1762	1689	1619	1552	0.103	
	8	2190	2124	2055	1984	1913	1842	1773	1707	1643	0.092	
	9	2223	2165	2104	2040	1975	1910	1846	1783	1722	0.083	
10	2249	2198	2144	2086	2027	1968	1908	1849	1791	0.076		
30/3 Dxx* F = 1943	0	793	702	629	559	498	448	407	372	342	1.059	
	1	1062	968	885	813	750	695	647	604	557	0.470	
	2	1232	1149	1071	1000	935	876	823	775	731	0.302	
	3	1339	1270	1203	1138	1077	1020	966	917	871	0.222	
	4	1408	1353	1296	1240	1185	1132	1081	1033	988	0.176	
	5	1455	1410	1363	1314	1266	1218	1172	1127	1084	0.146	
	6	1488	1451	1411	1370	1328	1286	1244	1203	1162	0.124	
	7	1511	1480	1447	1412	1376	1338	1301	1264	1227	0.108	
	8	1529	1503	1474	1444	1413	1380	1347	1313	1279	0.096	
	9	1542	1520	1496	1469	1442	1413	1384	1353	1323	0.086	
10	1552	1533	1512	1489	1465	1440	1414	1387	1359	0.078		

Shaded Area does not conform to SDI maximum fastener spacing of 36" o.c. for spans greater than 5' 0".

* D_{xx} is a warping factor dependent on the end fastener pattern and used in the equation for G' .

Values to the right of bold line may exceed the maximum recommended spans.

Deck Profile	Nominal Shear Strength due to Panel Buckling (S_{nb}), PLF									
	3.0	3.5	4.0	4.5	5.0	5.5	6.0	6.5	7.0	
F22	5161	3792	2903	2294	1858	1536	1290	1099	948	$\Omega_b = 2, \phi_b = .8$

$$G' = \frac{K_2}{K_4 + 0.3D_{xx}/L_v + 3K_1L_v} \text{ (kips/in)}$$

F Deck
 $K_2 = 870$
 $K_4 = 3.78$

Design Notes:

Choose more severe factored resistance:

LRFD lesser of $\phi_b S_{nb}$ and ϕS_n

ASD lesser of S_{nb}/Ω_b and S_n/Ω

If load = wind, see interaction calculator on web.



ROOF DECK - Weld Weld

B, F Deck 20 gage Diaphragm Tables $F_y = 40$ ksi

Fastener Support 5/8" ϕ puddle welds
 Side-Lap 5/8" ϕ puddle welds or 1 1/2" fillet weld

Strength/Fast.
 $Q_t = 2413$ lb.
 $Q_s = 1810$ lb.

Load	Ω	ϕ
Seismic	3.00	0.55
Wind	2.35	0.70
Other	2.65	0.60

Fastener Pattern	Side-Lap Conn./Span	Nominal Shear Strength (S_n), PLF									K1
		Span (L_v), Ft.									
		4.0	4.5	5.0	5.5	6.0	6.5	7.0	7.5	8.0	
36/7 Dxx* B = 97 F = 169	0	1198	1059	948	857	781	717	662	614	573	0.535
	1	1607	1445	1310	1186	1083	995	921	856	799	0.317
	2	1969	1782	1625	1492	1378	1274	1179	1097	1025	0.225
	3	2295	2090	1916	1766	1636	1523	1424	1337	1251	0.174
	4	2585	2370	2184	2022	1880	1755	1645	1547	1459	0.142
	5	2841	2622	2429	2258	2107	1973	1854	1747	1651	0.120
	6	3064	2847	2651	2476	2319	2178	2051	1937	1834	0.104
	7	3259	3046	2852	2675	2514	2369	2237	2118	2009	0.092
	8	3428	3223	3032	2856	2694	2546	2411	2288	2174	0.082
	9	3576	3379	3193	3020	2859	2711	2573	2447	2331	0.074
10	3704	3517	3338	3169	3010	2862	2724	2597	2478	0.068	
36/5 Dxx* B = 567 F = 663	0	1092	979	876	792	721	662	611	566	528	0.642
	1	1443	1310	1198	1103	1020	940	869	808	754	0.351
	2	1739	1595	1470	1362	1266	1183	1108	1043	980	0.242
	3	1983	1838	1708	1592	1489	1396	1314	1240	1173	0.184
	4	2183	2041	1912	1794	1687	1590	1502	1422	1349	0.149
	5	2344	2211	2085	1969	1861	1762	1672	1588	1511	0.125
	6	2475	2351	2232	2120	2015	1916	1824	1739	1660	0.108
	7	2582	2468	2357	2250	2148	2052	1961	1876	1796	0.094
	8	2669	2565	2462	2361	2264	2171	2082	1998	1919	0.084
	9	2740	2646	2551	2457	2365	2276	2190	2108	2030	0.076
10	2800	2714	2626	2539	2453	2368	2286	2207	2130	0.069	
36/4 Dxx* B = 802 F = 909	0	839	742	662	597	543	497	458	424	394	0.803
	1	1176	1072	984	908	842	776	717	665	620	0.394
	2	1442	1333	1236	1150	1074	1006	946	892	843	0.261
	3	1646	1541	1444	1355	1275	1202	1135	1075	1020	0.195
	4	1800	1703	1611	1525	1444	1370	1301	1238	1180	0.156
	5	1917	1830	1745	1663	1586	1513	1445	1381	1321	0.130
	6	2006	1928	1852	1776	1704	1634	1568	1505	1445	0.111
	7	2075	2006	1937	1869	1802	1736	1673	1612	1554	0.097
	8	2128	2068	2006	1944	1883	1822	1762	1704	1648	0.086
	9	2170	2117	2062	2007	1950	1894	1838	1784	1731	0.078
10	2204	2157	2108	2058	2007	1955	1903	1852	1802	0.071	

Shaded Area does not conform to SDI maximum fastener spacing of 36" o.c. for spans greater than 5' 0".

* D_{xx} is a warping factor dependent on the end fastener pattern and used in the equation for G' .

Values to the right of bold line may exceed the maximum recommended spans.

Deck Profile	Nominal Shear Strength due to Panel Buckling (S_{nb}), PLF									$\Omega_b = 2, \phi_b = .8$
	4.0	4.5	5.0	5.5	6.0	6.5	7.0	7.5	8.0	
F20	3923	3099	2510	2075	1743	1485	1281	1116	981	
B20	4621	3652	2958	2444	2054	1750	1509	1315	1155	

$$G' = \frac{K_2}{K_4 + 0.3D_{xx}/L_v + 3K_1L_v} \text{ (kips/in)}$$

B & F Deck
 $K_2 = 1056$
 $K_4 = 3.78$

Design Notes:

Choose more severe factored resistance:

LRFD lesser of $\phi_b S_{nb}$ and ϕS_n

ASD lesser of S_{nb}/Ω_b and S_n/Ω

If load = wind, see interaction calculator on web.



ROOF DECK - Weld Weld

F Deck 20 gage Diaphragm Tables $F_y = 40$ ksi

Fastener Support 5/8" ϕ puddle welds
Side-Lap 5/8" ϕ puddle welds or 1 1/2" fillet weld

Strength/Fast.
 $Q_t = 2413$ lb.
 $Q_s = 1810$ lb.

Load	Ω	ϕ
Seismic	3.00	0.55
Wind	2.35	0.70
Other	2.65	0.60

Nominal Shear Strength (S_n), PLF

Fastener Pattern	Side-Lap Conn./Span	Span (L_v), Ft.								K1	
		4.0	4.5	5.0	5.5	6.0	6.5	7.0	7.5		8.0
30/6 Dxx* F = 169	0	1073	948	848	766	698	640	590	547	510	0.713
	1	1500	1347	1210	1095	999	918	849	789	736	0.404
	2	1872	1691	1540	1412	1301	1197	1107	1030	962	0.282
	3	2208	2007	1837	1692	1566	1457	1361	1271	1189	0.216
	4	2508	2296	2112	1953	1814	1692	1585	1489	1404	0.175
	5	2773	2555	2363	2195	2046	1914	1797	1692	1599	0.148
	6	3005	2787	2592	2418	2262	2123	1998	1886	1784	0.127
	7	3208	2993	2798	2622	2462	2317	2187	2069	1961	0.112
	8	3384	3176	2984	2807	2646	2499	2364	2242	2129	0.100
	9	3537	3338	3150	2976	2815	2666	2530	2404	2288	0.090
10	3670	3480	3299	3129	2970	2821	2684	2556	2438	0.082	
30/4 Dxx* F = 1157	0	1023	919	822	742	676	620	572	530	494	0.802
	1	1364	1242	1138	1048	971	898	831	772	720	0.431
	2	1645	1514	1400	1299	1211	1132	1063	1000	945	0.294
	3	1871	1741	1624	1518	1423	1338	1261	1192	1129	0.224
	4	2050	1927	1812	1706	1609	1521	1440	1366	1298	0.180
	5	2192	2078	1969	1866	1771	1681	1599	1523	1452	0.151
	6	2305	2201	2099	2002	1909	1822	1740	1663	1591	0.130
	7	2395	2300	2207	2116	2028	1944	1864	1788	1716	0.114
	8	2467	2382	2297	2212	2129	2049	1972	1898	1828	0.102
	9	2526	2449	2372	2294	2216	2141	2067	1996	1928	0.092
10	2574	2505	2434	2363	2291	2220	2150	2082	2016	0.083	
30/3 Dxx* F = 1453	0	755	676	603	544	494	452	416	384	357	1.167
	1	1063	976	901	835	777	726	674	626	583	0.518
	2	1286	1201	1123	1052	988	930	878	831	788	0.333
	3	1445	1367	1293	1224	1160	1101	1046	995	948	0.245
	4	1556	1489	1423	1359	1298	1240	1186	1135	1087	0.194
	5	1636	1578	1520	1463	1407	1353	1301	1252	1205	0.160
	6	1694	1645	1594	1544	1493	1444	1396	1349	1304	0.137
	7	1738	1695	1652	1607	1562	1517	1473	1429	1387	0.119
	8	1770	1734	1696	1657	1617	1577	1536	1496	1457	0.106
	9	1796	1764	1731	1697	1661	1625	1589	1552	1515	0.095
10	1816	1788	1759	1729	1697	1665	1632	1598	1565	0.086	

Shaded Area does not conform to SDI maximum fastener spacing of 36" o.c. for spans greater than 5' 0".

* D_{xx} is a warping factor dependent on the end fastener pattern and used in the equation for G' .

Values to the right of bold line may exceed the maximum recommended spans.

Deck Profile	Nominal Shear Strength due to Panel Buckling (S_{nb}), PLF								$\Omega_b = 2, \phi_b = .8$
	4.0	4.5	5.0	5.5	6.0	6.5	7.0	7.5	8.0
F20	3923	3099	2510	2075	1743	1485	1281	1116	981

$$G' = \frac{K_2}{K_4 + 0.3D_{xx}/L_v + 3K_1L_v} \text{ (kips/in)}$$

F Deck
 $K_2 = 1056$
 $K_4 = 3.78$

Design Notes:

Choose more severe factored resistance:

LRFD lesser of $\phi_b S_{nb}$ and ϕS_n

ASD lesser of S_{nb}/Ω_b and S_n/Ω

If load = wind, see interaction calculator on web.



ROOF DECK - Weld Weld

B, F Deck 18 gage Diaphragm Tables $F_y = 40$ ksi

Fastener Support 5/8" ϕ puddle welds
Side-Lap 5/8" ϕ puddle welds or 1 1/2" fillet weld

Strength/Fast.
 $Q_t = 3132$ lb.
 $Q_b = 2349$ lb.

Load	Ω	ϕ
Seismic	3.00	0.55
Wind	2.35	0.70
Other	2.65	0.60

Fastener Pattern	Side-Lap Conn./Span	Nominal Shear Strength (S_n), PLF								K1	
		Span (L), Ft.									
		5.0	5.5	6.0	6.5	7.0	7.5	8.0	8.5	9.0	
36/7 Dxx* B = 63 F = 111	0	1240	1122	1023	940	868	806	752	705	662	0.615
	1	1703	1549	1415	1301	1204	1120	1046	981	923	0.364
	2	2109	1936	1788	1661	1540	1433	1340	1257	1184	0.259
	3	2486	2292	2124	1977	1849	1735	1633	1534	1445	0.200
	4	2835	2624	2440	2278	2135	2007	1894	1792	1700	0.164
	5	3153	2931	2735	2561	2406	2267	2143	2030	1929	0.138
	6	3441	3214	3010	2827	2663	2515	2381	2260	2149	0.120
	7	3702	3472	3264	3075	2904	2749	2607	2479	2361	0.106
	8	3935	3707	3497	3305	3130	2969	2822	2688	2564	0.094
	9	4145	3920	3711	3518	3340	3176	3025	2886	2757	0.085
10	4332	4113	3907	3715	3536	3370	3217	3074	2942	0.078	
36/5 Dxx* B = 372 F = 435	0	1146	1036	945	868	802	744	694	650	610	0.738
	1	1555	1431	1324	1229	1137	1057	987	926	871	0.404
	2	1908	1767	1644	1535	1439	1353	1277	1202	1132	0.278
	3	2216	2066	1932	1812	1705	1609	1522	1444	1372	0.212
	4	2481	2328	2189	2063	1949	1845	1751	1664	1586	0.171
	5	2707	2556	2416	2288	2170	2061	1961	1870	1785	0.144
	6	2898	2752	2615	2487	2368	2257	2155	2059	1971	0.124
	7	3059	2920	2788	2663	2545	2434	2331	2234	2143	0.109
	8	3195	3065	2939	2818	2703	2594	2490	2393	2301	0.097
	9	3311	3189	3070	2954	2843	2736	2635	2538	2446	0.087
10	3409	3295	3183	3074	2967	2864	2765	2670	2579	0.080	
36/4 Dxx* B = 526 F = 597	0	869	784	714	654	603	559	521	486	456	0.923
	1	1277	1178	1092	1016	939	872	814	763	717	0.454
	2	1605	1493	1394	1306	1228	1157	1094	1037	978	0.301
	3	1874	1759	1654	1560	1474	1396	1324	1259	1200	0.225
	4	2091	1979	1875	1778	1689	1607	1531	1461	1396	0.180
	5	2264	2159	2059	1964	1875	1792	1714	1642	1574	0.150
	6	2403	2306	2212	2121	2035	1953	1876	1803	1734	0.128
	7	2515	2426	2338	2253	2171	2092	2017	1945	1876	0.112
	8	2604	2524	2444	2365	2287	2212	2140	2070	2002	0.099
	9	2677	2604	2531	2458	2386	2315	2246	2179	2114	0.09
10	2737	2671	2604	2537	2471	2404	2339	2275	2213	0.081	

Shaded Area does not conform to SDI maximum fastener spacing of 36" o.c. for spans greater than 5' 0".

* D_{xx} is a warping factor dependent on the end fastener pattern and used in the equation for G' .

Values to the right of bold line may exceed the maximum recommended spans.

Deck Profile	Nominal Shear Strength due to Panel Buckling (S_{nb}), PLF								$\Omega_b = 2, \phi_b = .8$	
	5.0	5.5	6.0	6.5	7.0	7.5	8.0	8.5	9.0	
F18	4200	3471	2917	2485	2143	1867	1641	1453	1296	
B18	4824	3987	3350	2854	2461	2144	1884	1669	1489	

$$G' = \frac{K_2}{K_4 + 0.3D_{xx}/L_v + 3K_1L_v} \text{ (kips/in)}$$

B & F Deck
 $K_2 = 1398$
 $K_4 = 3.78$

Design Notes:

Choose more severe factored resistance:

LRFD lesser of $\phi_b S_{nb}$ and ϕS_n

ASD lesser of S_{nt}/Ω_b and S_n/Ω

If load = wind, see interaction calculator on web.



ROOF DECK - Weld Weld

F Deck 18 gage Diaphragm Tables $F_y = 40$ ksi

Fastener Support 5/8" ϕ puddle welds
Side-Lap 5/8" ϕ puddle welds or 1 1/2" fillet weld

Strength/Fast.
 $Q_t = 3132$ lb.
 $Q_s = 2349$ lb.

Load	Ω	ϕ
Seismic	3.00	0.55
Wind	2.35	0.70
Other	2.65	0.60

Nominal Shear Strength (S_n), PLF

Fastener Pattern	Side-Lap Conn./Span	Span (L_v), Ft.								K1	
		5.0	5.5	6.0	6.5	7.0	7.5	8.0	8.5		9.0
30/6 Dxx* F = 111	0	1109	1003	914	840	775	720	671	628	590	0.821
	1	1579	1430	1306	1201	1111	1033	965	904	851	0.465
	2	1999	1833	1692	1562	1446	1346	1258	1181	1112	0.324
	3	2385	2196	2033	1891	1767	1658	1552	1457	1373	0.249
	4	2741	2534	2354	2196	2057	1933	1823	1724	1634	0.202
	5	3068	2849	2655	2484	2332	2197	2075	1965	1866	0.170
	6	3364	3138	2936	2755	2593	2447	2316	2197	2089	0.147
	7	3632	3403	3195	3008	2839	2685	2546	2419	2303	0.129
	8	3873	3644	3434	3243	3069	2909	2764	2631	2509	0.115
	9	4089	3863	3654	3461	3283	3120	2970	2832	2705	0.104
10	4282	4061	3854	3662	3483	3318	3165	3023	2892	0.095	
30/4 Dxx* F = 760	0	1076	973	887	814	751	697	650	608	571	0.923
	1	1477	1361	1261	1173	1087	1011	944	885	832	0.496
	2	1817	1686	1571	1469	1379	1298	1226	1161	1093	0.339
	3	2108	1970	1847	1736	1637	1547	1465	1391	1323	0.257
	4	2352	2215	2089	1974	1869	1773	1685	1604	1530	0.207
	5	2555	2422	2298	2182	2075	1976	1885	1800	1721	0.174
	6	2724	2598	2478	2365	2258	2158	2065	1978	1897	0.150
	7	2865	2746	2632	2523	2419	2320	2227	2140	2057	0.131
	8	2981	2871	2764	2660	2560	2464	2373	2286	2203	0.117
	9	3078	2977	2877	2779	2683	2591	2502	2417	2335	0.105
10	3160	3067	2974	2881	2791	2703	2617	2534	2455	0.096	
30/3 Dxx* F = 954	0	792	715	650	595	549	508	473	441	413	1.343
	1	1169	1083	1008	942	883	821	766	718	674	0.596
	2	1457	1366	1283	1208	1140	1078	1022	971	925	0.383
	3	1679	1589	1506	1429	1358	1292	1231	1175	1123	0.282
	4	1846	1764	1685	1610	1539	1473	1411	1352	1298	0.223
	5	1973	1899	1826	1756	1689	1625	1563	1505	1450	0.185
	6	2069	2004	1938	1874	1811	1751	1692	1636	1582	0.157
	7	2144	2086	2027	1929	1912	1855	1800	1746	1695	0.137
	8	2202	2151	2099	2046	1994	1942	1891	1840	1791	0.122
	9	2247	2202	2156	2109	2062	2014	1967	1920	1874	0.109
10	2284	2244	2203	2161	2118	2075	2031	1988	1945	0.099	

Shaded Area does not conform to SDI maximum fastener spacing of 36" o.c. for spans greater than 5' 0".

* D_{xx} is a warping factor dependent on the end fastener pattern and used in the equation for G' .

Values to the right of bold line may exceed the maximum recommended spans.

Deck Profile	Nominal Shear Strength due to Panel Buckling (S_{nb}), PLF								$\Omega_b = 2, \phi_b = .8$	
	5.0	5.5	6.0	6.5	7.0	7.5	8.0	8.5	9.0	
F18	4200	3471	2917	2485	2143	1867	1641	1453	1296	

$$G' = \frac{K_2}{K_4 + 0.3D_{xx}/L_v + 3K_1L_v} \text{ (kips/in)}$$

F Deck
 $K_2 = 1398$
 $K_4 = 3.78$

Design Notes:

Choose more severe factored resistance:

LRFD lesser of $\phi_b S_{nb}$ and ϕS_n

ASD lesser of S_{nt}/Ω_b and S_n/Ω

If load = wind, see interaction calculator on web.



ROOF DECK - Weld Weld

B Deck 16 gage Diaphragm Tables $F_y = 40$ ksi

Fastener Support 5/8" ϕ puddle welds
Side-Lap 5/8" ϕ puddle welds or 1 1/2" fillet weld

Strength/Fast.
 $Q_r = 3867$ lb.
 $Q_s = 2900$ lb.

Load	Ω	ϕ
Seismic	3.00	0.55
Wind	2.35	0.70
Other	2.65	0.60

Fastener Pattern	Side-Lap Conn./Span	Nominal Shear Strength (S_n), PLF									K1
		Span (L_v), Ft.									
		6.0	6.5	7.0	7.5	8.0	8.5	9.0	9.5	10.0	
36/7 Dxx* B = 45	0	1271	1168	1080	1004	937	878	825	779	736	0.691
	1	1754	1614	1494	1390	1299	1219	1148	1084	1026	0.409
	2	2208	2050	1909	1777	1662	1560	1470	1389	1316	0.290
	3	2622	2441	2282	2142	2018	1901	1792	1694	1606	0.225
	4	3012	2812	2635	2478	2338	2212	2098	1995	1896	0.184
	5	3377	3162	2971	2799	2645	2507	2381	2267	2162	0.155
	6	3716	3490	3287	3104	2939	2789	2653	2529	2415	0.135
	7	4029	3796	3585	3393	3219	3060	2915	2782	2659	0.119
	8	4317	4080	3864	3666	3484	3318	3165	3025	2895	0.106
	9	4581	4343	4124	3921	3735	3563	3404	3258	3122	0.096
36/5 Dxx* B = 262	0	1175	1079	998	927	865	810	761	718	679	0.829
	1	1635	1521	1412	1313	1227	1151	1084	1023	969	0.454
	2	2029	1895	1776	1671	1576	1491	1406	1328	1259	0.312
	3	2385	2238	2105	1986	1879	1782	1694	1614	1541	0.238
	4	2703	2547	2406	2278	2161	2055	1957	1868	1786	0.192
	5	2983	2824	2678	2544	2421	2308	2204	2108	2019	0.161
	6	3228	3070	2923	2787	2660	2542	2433	2332	2238	0.139
	7	3442	3287	3142	3005	2877	2758	2646	2541	2443	0.122
	8	3628	3479	3337	3202	3074	2954	2841	2734	2634	0.109
	9	3789	3647	3510	3378	3253	3133	3020	2913	2811	0.098
36/4 Dxx* B = 371	0	890	816	753	699	651	609	571	538	507	1.037
	1	1348	1256	1167	1085	1013	950	893	843	797	0.510
	2	1721	1613	1516	1429	1351	1280	1216	1148	1087	0.338
	3	2042	1926	1819	1723	1635	1555	1481	1414	1352	0.253
	4	2314	2195	2085	1984	1890	1804	1724	1650	1582	0.202
	5	2541	2425	2315	2212	2117	2027	1943	1865	1793	0.168
	6	2730	2619	2512	2411	2316	2225	2141	2060	1985	0.144
	7	2887	2782	2680	2583	2490	2401	2316	2236	2159	0.126
	8	3017	2919	2824	2731	2641	2555	2472	2393	2317	0.112
	9	3125	3035	2946	2858	2773	2690	2610	2532	2458	0.101
10	3215	3132	3050	2968	2887	2809	2731	2657	2584	0.091	

Shaded Area does not conform to SDI maximum fastener spacing of 36" o.c. for spans greater than 5' 0".

* D_{xx} is a warping factor dependent on the end fastener pattern and used in the equation for G' .

Deck Profile	Nominal Shear Strength due to Panel Buckling (S_{nb}), PLF									$\Omega_b = 2, \phi_b = .8$
	6.0	6.5	7.0	7.5	8.0	8.5	9.0	9.5	10.0	
B16	4884	4162	3588	3126	2747	2434	2171	1948	1758	

$$G' = \frac{K_2}{K_4 + 0.3D_{xx}/L_v + 3K_1L_v} \text{ (kips/in)}$$

B Deck
 $K_2 = 1764$
 $K_4 = 3.78$

Design Notes:

Choose more severe factored resistance:

LRFD lesser of $\phi_b S_{nb}$ and ϕS_n

ASD lesser of S_{nb}/Ω_b and S_n/Ω

If load = wind, see interaction calculator on web.



ROOF DECK - Weld Weld

N Deck 22 & 20 gage Diaphragm Tables F_y = 40 ksi

Load	Ω	φ
Seismic	3.00	0.55
Wind	2.35	0.70
Other	2.65	0.60

Fastener Support 5/8" φ puddle welds
Side-Lap 5/8" φ puddle welds or 1 1/2" fillet weld

Canam does not recommend welded side laps for 22 gage.

Nominal Shear Strength (S_n), PLF 22 ga. design thickness (t)=0.0295 in.

Fastener Pattern	Side-Lap Conn./Span	Strength/Fast. Q _t = 2010 lb. Q _s = 1507 lb.									K1
		Span (L _v), Ft.									
		8.0	8.5	9.0	9.5	10.0	10.5	11.0	11.5	12.0	
	0	322	303	286	271	258	246	234	224	215	1.093
	2	699	658	621	589	559	533	508	486	466	0.356
	3	887	835	789	747	710	676	645	617	592	0.266
	4	1055	1000	950	905	861	820	782	748	717	0.213
24/4	5	1205	1145	1089	1039	993	950	911	875	842	0.177
	6	1345	1281	1221	1167	1117	1070	1028	988	951	0.152
Dxx*	7	1475	1408	1345	1288	1234	1185	1139	1096	1056	0.133
N = 653	8	1595	1526	1461	1401	1346	1294	1245	1200	1157	0.118
	9	1705	1635	1570	1508	1450	1396	1346	1298	1254	0.106
	10	1806	1736	1670	1608	1549	1493	1441	1392	1346	0.096
	11	1866	1829	1763	1700	1641	1585	1532	1481	1434	0.088

Nominal Shear Strength (S_n), PLF 20 ga. design thickness (t)=0.0358 in.

Fastener Pattern	Side-Lap Conn./Span	Strength/Fast. Q _t = 2413 lb. Q _s = 1810 lb.									K1
		Span (L _v), Ft.									
		9.0	9.5	10.0	10.5	11.0	11.5	12.0	12.5	13.0	
	0	344	326	310	295	281	269	258	248	238	1.204
	3	947	897	852	812	775	741	710	682	656	0.293
	4	1141	1086	1033	984	939	899	861	827	795	0.234
24/4	5	1308	1248	1192	1141	1094	1051	1010	972	934	0.195
	6	1467	1401	1341	1285	1234	1186	1142	1100	1062	0.167
Dxx*	7	1615	1546	1482	1423	1367	1316	1268	1223	1181	0.146
N=488	8	1755	1683	1616	1553	1495	1440	1389	1342	1297	0.130
	9	1885	1811	1742	1677	1616	1559	1506	1455	1408	0.117
	10	2005	1930	1860	1793	1731	1672	1616	1564	1514	0.106
	11	2117	2041	1970	1903	1839	1779	1722	1668	1616	0.097
	12	2220	2145	2073	2006	1941	1880	1822	1766	1714	0.090

Shaded Area does not conform to SDI maximum fastener spacing of 36" o.c. for spans greater than 5' 0".

* D_{xx} is a warping factor dependent on the end fastener pattern and used in the equation for G'.

Deck Profile	K ₂	Nominal Shear Strength due to Panel Buckling (S _{nb}), PLF Ω _b = 2, φ _b = .8										
		8.0	8.5	9.0	9.5	10.0	10.5	11.0	11.5	12.0	12.5	13.0
N22	870	2205	1953	1742	1564	1411	1280	1166	1067	908		
N20	1056			2445	2195	1981	1797	1637	1498	1376	1268	1172

$$G' = \frac{K_2}{K_4 + 0.3D_{xx}/L_v + 3K_1L_v} \text{ (kips/in)}$$

N Deck K₄ = 4.31

Design Notes:
Choose more severe factored resistance:
LRFD lesser of φ_bS_{nb} and φS_n
ASD lesser of S_{nb}/Ω_b and S_n/Ω
If load = wind, see interaction calculator on web.

TABLES



ROOF DECK - Weld Weld

N Deck 18 & 16 gage Diaphragm Tables $F_y = 40$ ksi

Fastener Support 5/8" ϕ puddle welds
Side-Lap 5/8" ϕ puddle welds or 1 1/2" fillet weld

Load	Ω	ϕ
Seismic	3.00	0.55
Wind	2.35	0.70
Other	2.65	0.60

Nominal Shear Strength (S_n), PLF 18 ga. design thickness (t)=0.0474 in.

Fastener Pattern	Side-Lap Conn./Span	Strength/Fast. $Q_t = 3132$ lb. $Q_s = 2349$ lb.									K1
		Span (L_v), Ft.									
		10.0	10.5	11.0	11.5	12.0	12.5	13.0	13.5	14.0	
	0	402	383	365	349	335	321	309	298	287	1.385
	3	1106	1054	1006	962	922	885	851	820	790	0.337
	4	1341	1277	1219	1166	1118	1073	1032	994	958	0.269
	5	1547	1481	1420	1364	1311	1261	1213	1168	1126	0.224
24/4	6	1740	1668	1601	1539	1482	1428	1378	1331	1287	0.192
	7	1924	1847	1775	1708	1646	1588	1533	1482	1434	0.168
Dxx*	8	2097	2016	1940	1870	1803	1741	1683	1628	1577	0.149
N = 321	9	2260	2176	2098	2024	1954	1889	1827	1769	1715	0.134
	10	2414	2328	2246	2170	2098	2030	1966	1905	1848	0.122
	11	2557	2470	2387	2309	2235	2164	2098	2035	1976	0.112
	12	2691	2603	2519	2440	2364	2293	2225	2160	2098	0.103
	13	2816	2728	2644	2564	2487	2414	2345	2279	2216	0.096

Nominal Shear Strength (S_n), PLF 16 ga. design thickness (t)=0.0598 in.

Fastener Pattern	Side-Lap Conn./Span	Strength/Fast. $Q_t = 3867$ lb. $Q_s = 2900$ lb.								K1	
		Span (L_v), Ft.									
		11.0	11.5	12.0	12.5	13.0	13.5	14.0	14.5	15.0	
	0	451	431	413	397	382	367	354	342	331	1.556
	3	1242	1188	1138	1093	1051	1012	976	942	911	0.379
	4	1505	1440	1380	1325	1274	1227	1183	1142	1104	0.303
	5	1753	1684	1619	1557	1497	1441	1390	1342	1297	0.252
24/4	6	1977	1900	1829	1763	1701	1643	1589	1538	1490	0.216
	7	2191	2109	2032	1960	1893	1830	1771	1715	1663	0.189
Dxx*	8	2395	2308	2226	2150	2078	2010	1947	1887	1830	0.168
N=226	9	2589	2498	2412	2332	2256	2184	2117	2053	1993	0.151
	10	2773	2679	2590	2506	2427	2352	2281	2214	2150	0.137
	11	2947	2850	2759	2672	2590	2512	2439	2369	2303	0.126
	12	3110	3012	2919	2830	2746	2666	2590	2518	2449	0.116
	13	3264	3165	3071	2981	2895	2813	2736	2661	2591	0.108

Shaded Area does not conform to SDI maximum fastener spacing of 36" o.c. for spans greater than 5' 0".

*Dxx is a warping factor dependent on the end fastener pattern and used in the equation for G'.

Tables are based on 3 span conditions. Values to the right of double lines exceed practical production limits. Use 2 span conditions. At 2 span strengths are generally higher and stiffness reduction is less than 19% of the table values.

Deck Profile	K_2	Nominal Shear Strength due to Panel Buckling (S_{nb}), PLF $\Omega_b = 2, \phi_b = .8$										
		10.0	10.5	11.0	11.5	12.0	12.5	13.0	13.5	14.0	14.5	15.0
N18	1398	3206	2908	2649	2424	2226	2052	1897	1759	1636		
N16	1764			3990	3651	3353	3090	2857	2649	2463	2296	2146

$$G' = \frac{K_2}{K_4 + 0.3D_{xx}/L_v + 3K_1L_v} \text{ (kips/in)}$$

N Deck $K_4 = 4.31$

Design Notes:
 Choose more severe factored resistance:
 LRFD lesser of $\phi_b S_{nb}$ and ϕS_n
 ASD lesser of S_{nb}/Ω_b and S_n/Ω
 If load = wind, see interaction calculator on web.

DIAPHRAGM

TABLES



ROOF DECK - Weld Screw

B, F Deck 22 gage Diaphragm Tables $F_y = 40$ ksi

Fastener Support 5/8" ϕ puddle welds
Side-Lap #10 screw

Strength/Fast.
 $Q_r = 2010$ lb.
 $Q_s = 634$ lb.

Load	Ω	ϕ
Seismic	3.00	0.55
Wind	2.35	0.70
Other	2.65	0.60

Fastener Pattern	Side-Lap Conn./Span	Nominal Shear Strength (S_n), PLF										K1
		Span (L_v), Ft.										
		3.0	3.5	4.0	4.5	5.0	5.5	6.0	6.5	7.0		
36/7 Dxx* B = 129 F = 226	0	1314	1142	994	878	785	709	646	593	547	0.486	
	1	1488	1299	1151	1019	912	825	752	690	637	0.377	
	2	1652	1449	1288	1157	1039	940	858	788	728	0.308	
	3	1808	1593	1420	1279	1163	1055	963	885	819	0.261	
	4	1954	1730	1547	1397	1272	1167	1069	983	909	0.226	
	5	2090	1859	1669	1512	1379	1267	1170	1081	1000	0.199	
	6	2217	1982	1786	1622	1483	1364	1262	1173	1091	0.178	
	7	2336	2098	1897	1727	1583	1459	1351	1258	1176	0.161	
	8	2445	2207	2003	1829	1680	1551	1439	1341	1255	0.147	
	9	2547	2310	2104	1926	1773	1640	1523	1421	1331	0.135	
10	2641	2406	2200	2020	1863	1726	1606	1500	1407	0.125		
36/5 Dxx* B = 758 F = 886	0	1162	1022	910	811	725	655	596	547	504	0.583	
	1	1310	1160	1038	938	852	770	702	644	595	0.433	
	2	1443	1287	1158	1050	959	882	808	742	685	0.345	
	3	1563	1404	1270	1157	1060	977	905	839	776	0.286	
	4	1670	1511	1375	1257	1156	1068	992	925	866	0.245	
	5	1765	1609	1471	1351	1246	1155	1075	1004	942	0.214	
	6	1850	1697	1560	1439	1332	1238	1154	1080	1015	0.190	
	7	1926	1777	1642	1520	1412	1316	1230	1154	1085	0.171	
	8	1993	1849	1717	1596	1488	1390	1303	1224	1153	0.155	
	9	2052	1914	1785	1666	1558	1460	1371	1291	1219	0.142	
10	2105	1973	1848	1732	1624	1526	1437	1355	1281	0.131		
36/4 Dxx* B = 1072 F = 1216	0	890	784	696	613	547	493	448	410	377	0.729	
	1	1033	918	824	746	674	608	554	507	468	0.509	
	2	1158	1039	939	854	783	721	659	605	558	0.391	
	3	1265	1146	1043	955	878	812	754	702	649	0.318	
	4	1357	1240	1137	1047	967	897	836	782	734	0.267	
	5	1435	1323	1221	1130	1049	977	913	856	805	0.231	
	6	1502	1395	1296	1206	1125	1051	986	926	873	0.203	
	7	1560	1458	1363	1275	1194	1120	1053	993	938	0.181	
	8	1609	1514	1422	1337	1257	1183	1116	1055	998	0.164	
	9	1651	1562	1475	1392	1314	1242	1175	1113	1056	0.149	
10	1688	1604	1522	1442	1367	1296	1229	1167	1110	0.137		

Shaded Area does not conform to SDI maximum fastener spacing of 36" o.c. for spans greater than 5' 0".

* Dxx is a warping factor dependent on the end fastener pattern and used in the equation for G'.

Values to the right of bold line may exceed the maximum recommended spans.

Deck Profile	Nominal Shear Strength due to Panel Buckling (S_{nb}), PLF										$\Omega_b = 2, \phi_b = .8$	
	3.0	3.5	4.0	4.5	5.0	5.5	6.0	6.5	7.0			
F22	5161	3792	2903	2294	1858	1536	1290	1099	948			
B22	6011	4416	3381	2671	2164	1788	1503	1280	1104			

$$G' = \frac{K_2}{K_4 + 0.3D_{xx}/L_v + 3K_1L_v} \text{ (kips/in)}$$

B & F Deck
 $K_2 = 870$
 $K_4 = 3.78$

Design Notes:

Choose more severe factored resistance:

LRFD lesser of $\phi_b S_{nb}$ and ϕS_n

ASD lesser of S_{nb}/Ω_b and S_n/Ω

If load = wind, see interaction calculator on web.



ROOF DECK - Weld Screw

F Deck 22 gage Diaphragm Tables $F_y = 40$ ksi

Fastener Support 5/8" ϕ puddle welds
Side-Lap #10 screw

Strength/Fast.
 $Q_t = 2010$ lb.
 $Q_s = 634$ lb.

Load	Ω	ϕ
Seismic	3.00	0.55
Wind	2.35	0.70
Other	2.65	0.60

Nominal Shear Strength (S_n), PLF

Fastener Pattern	Side-Lap Conn./Span	Span (L_v), Ft.								K1	
		3.0	3.5	4.0	4.5	5.0	5.5	6.0	6.5		7.0
30/6 Dxx* F = 226	0	1194	1023	889	785	702	633	576	528	487	0.647
	1	1374	1196	1048	926	828	749	682	626	578	0.491
	2	1545	1351	1198	1067	955	864	788	724	668	0.395
	3	1706	1499	1333	1199	1082	979	894	821	759	0.331
	4	1859	1640	1464	1320	1200	1095	999	919	850	0.284
	5	2001	1775	1590	1437	1309	1201	1105	1016	940	0.249
	6	2134	1902	1710	1550	1415	1300	1202	1114	1031	0.222
	7	2259	2022	1825	1658	1517	1397	1293	1202	1121	0.200
	8	2374	2136	1934	1763	1616	1490	1381	1286	1203	0.182
	9	2481	2243	2038	1863	1712	1581	1468	1368	1281	0.167
10	2580	2343	2137	1959	1804	1669	1552	1449	1357	0.154	
30/4 Dxx* F = 1547	0	1085	956	852	761	680	614	559	512	472	0.728
	1	1228	1090	978	885	806	729	664	609	562	0.536
	2	1355	1213	1094	995	910	838	770	707	653	0.424
	3	1467	1324	1202	1098	1008	930	863	804	744	0.350
	4	1567	1425	1301	1194	1100	1019	947	885	829	0.299
	5	1654	1515	1392	1283	1187	1102	1028	962	903	0.260
	6	1730	1596	1474	1365	1268	1181	1104	1035	974	0.231
	7	1797	1668	1549	1441	1343	1255	1176	1105	1042	0.207
	8	1856	1733	1617	1510	1413	1325	1245	1172	1107	0.188
	9	1908	1790	1679	1574	1478	1390	1309	1236	1169	0.172
10	1953	1842	1735	1633	1538	1451	1370	1296	1228	0.159	
30/3 Dxx* F = 1943	0	793	702	629	559	498	448	407	372	342	1.059
	1	920	826	746	678	621	564	512	469	432	0.696
	2	1027	932	849	778	716	663	616	567	523	0.518
	3	1114	1022	940	867	803	747	696	652	612	0.413
	4	1186	1099	1019	947	881	823	771	724	682	0.343
	5	1245	1164	1087	1017	952	893	839	791	747	0.293
	6	1294	1219	1146	1078	1015	956	902	853	808	0.256
	7	1334	1265	1197	1132	1070	1013	959	910	864	0.227
	8	1368	1304	1241	1179	1120	1064	1011	962	916	0.204
	9	1396	1338	1279	1221	1164	1110	1059	1010	965	0.186
10	1420	1366	1312	1257	1204	1152	1102	1054	1009	0.170	

Shaded Area does not conform to SDI maximum fastener spacing of 36" o.c. for spans greater than 5' 0".

* D_{xx} is a warping factor dependent on the end fastener pattern and used in the equation for G' .

Values to the right of bold line may exceed the maximum recommended spans.

Deck Profile	Nominal Shear Strength due to Panel Buckling (S_{nb}), PLF								$\Omega_b = 2, \phi_b = .8$	
	3.0	3.5	4.0	4.5	5.0	5.5	6.0	6.5	7.0	
F22	5161	3792	2903	2294	1858	1536	1290	1099	948	

$$G' = \frac{K_2}{K_4 + 0.3D_{xx}/L_v + 3K_1L_v} \text{ (kips/in)}$$

F Deck
 $K_2 = 870$
 $K_4 = 3.78$

Design Notes:

Choose more severe factored resistance:

LRFD lesser of $\phi_b S_{nb}$ and ϕS_n

ASD lesser of S_{nb}/Ω_b and S_n/Ω

If load = wind, see interaction calculator on web.



ROOF DECK - Weld Screw

B, F Deck 20 gage Diaphragm Tables $F_y = 40$ ksi

Fastener Support 5/8" ϕ puddle welds
Side-Lap #10 screw

Strength/Fast.
 $Q_r = 2413$ lb.
 $Q_s = 770$ lb.

Load	Ω	ϕ
Seismic	3.00	0.55
Wind	2.35	0.70
Other	2.65	0.60

Fastener Pattern	Side-Lap Conn./Span	Nominal Shear Strength (S_n), PLF									K1
		Span (L_v), Ft.									
		4.0	4.5	5.0	5.5	6.0	6.5	7.0	7.5	8.0	
36/7 Dxx* B = 97 F = 169	0	1198	1059	948	857	781	717	662	614	573	0.535
	1	1383	1230	1102	997	910	835	772	717	669	0.415
	2	1550	1393	1256	1137	1038	954	882	820	765	0.340
	3	1710	1541	1400	1277	1166	1072	992	922	861	0.287
	4	1864	1684	1533	1406	1294	1191	1102	1025	958	0.249
	5	2012	1822	1663	1527	1411	1309	1212	1128	1054	0.219
	6	2153	1955	1788	1645	1522	1416	1322	1230	1150	0.196
	7	2288	2083	1909	1760	1631	1518	1419	1332	1246	0.178
	8	2416	2206	2026	1871	1736	1618	1514	1422	1341	0.162
	9	2538	2324	2139	1979	1839	1716	1607	1511	1425	0.149
10	2653	2437	2248	2083	1939	1811	1699	1598	1508	0.138	
36/5 Dxx* B = 567 F = 663	0	1092	979	876	792	721	662	611	566	528	0.642
	1	1248	1127	1027	932	849	780	721	669	624	0.477
	2	1394	1264	1155	1062	978	898	830	772	720	0.380
	3	1530	1393	1277	1177	1091	1015	940	874	816	0.315
	4	1656	1514	1393	1287	1195	1115	1044	977	912	0.270
	5	1772	1628	1502	1392	1296	1211	1135	1068	1008	0.236
	6	1880	1734	1606	1492	1392	1303	1224	1153	1090	0.209
	7	1978	1833	1703	1587	1484	1392	1309	1235	1169	0.188
	8	2068	1924	1794	1676	1571	1477	1391	1315	1245	0.171
	9	2151	2009	1879	1761	1654	1558	1470	1391	1319	0.156
10	2227	2087	1958	1841	1733	1635	1546	1465	1391	0.144	
36/4 Dxx* B = 802 F = 909	0	839	742	662	597	543	497	458	424	394	0.803
	1	991	897	816	737	671	616	568	527	490	0.561
	2	1130	1029	942	868	800	734	678	629	587	0.431
	3	1256	1150	1058	978	909	848	788	732	683	0.350
	4	1370	1261	1166	1082	1008	943	885	833	779	0.294
	5	1471	1362	1265	1178	1101	1033	971	916	866	0.254
	6	1562	1454	1356	1268	1189	1118	1053	995	943	0.224
	7	1642	1536	1439	1351	1270	1198	1131	1071	1016	0.200
	8	1714	1611	1515	1427	1346	1273	1205	1143	1087	0.180
	9	1777	1678	1585	1498	1417	1343	1274	1211	1153	0.164
10	1833	1738	1648	1562	1483	1408	1340	1276	1217	0.151	

Shaded Area does not conform to SDI maximum fastener spacing of 36" o.c. for spans greater than 5' 0".

* Dxx is a warping factor dependent on the end fastener pattern and used in the equation for G'.

Values to the right of bold line may exceed the maximum recommended spans.

Deck Profile	Nominal Shear Strength due to Panel Buckling (S_{nb}), PLF									$\Omega_b = 2, \phi_b = .8$
	4.0	4.5	5.0	5.5	6.0	6.5	7.0	7.5	8.0	
F20	3923	3099	2510	2075	1743	1485	1281	1116	981	
B20	4621	3652	2958	2444	2054	1750	1509	1315	1155	

$$G' = \frac{K_2}{K_4 + 0.3D_{xx}/L_v + 3K_1L_v} \text{ (kips/in)}$$

B & F Deck
 $K_2 = 1056$
 $K_4 = 3.78$

Design Notes:
Choose more severe factored resistance:
LRFD lesser of $\phi_b S_{nb}$ and ϕS_n
ASD lesser of S_{nb}/Ω_b and S_n/Ω
If load = wind, see interaction calculator on web.

DIAPHRAGM



ROOF DECK - Weld Screw

F Deck 20 gage Diaphragm Tables $F_y = 40$ ksi

Fastener Support 5/8" ϕ puddle welds
Side-Lap #10 screw

Strength/Fast.
 $Q_t = 2413$ lb.
 $Q_b = 770$ lb.

Load	Ω	ϕ
Seismic	3.00	0.55
Wind	2.35	0.70
Other	2.65	0.60

Nominal Shear Strength (S_n), PLF

Fastener Pattern	Side-Lap Conn./Span	Span (L_v), Ft.								K1	
		4.0	4.5	5.0	5.5	6.0	6.5	7.0	7.5		8.0
30/6 Dxx* F = 169	0	1073	948	848	766	698	640	590	547	510	0.713
	1	1265	1119	1002	906	826	758	700	650	606	0.541
	2	1442	1290	1156	1046	954	877	810	753	702	0.435
	3	1606	1445	1310	1186	1082	995	920	855	799	0.364
	4	1765	1591	1447	1326	1211	1114	1030	958	895	0.313
	5	1917	1732	1579	1449	1338	1232	1140	1061	991	0.275
	6	2062	1869	1707	1569	1450	1348	1250	1163	1087	0.245
	7	2201	2001	1831	1685	1560	1451	1356	1266	1183	0.220
	8	2333	2127	1950	1799	1668	1553	1453	1364	1280	0.201
	9	2459	2248	2066	1909	1772	1652	1547	1453	1370	0.184
10	2578	2364	2178	2016	1874	1749	1639	1542	1454	0.170	
30/4 Dxx* F = 1157	0	1023	919	822	742	676	620	572	530	494	0.802
	1	1176	1064	970	882	804	738	682	633	590	0.590
	2	1317	1197	1095	1008	933	857	792	736	686	0.467
	3	1447	1322	1214	1121	1040	969	902	838	782	0.386
	4	1567	1438	1326	1228	1142	1066	999	940	879	0.329
	5	1676	1546	1430	1329	1239	1159	1089	1025	969	0.287
	6	1776	1645	1528	1424	1331	1248	1174	1108	1048	0.254
	7	1866	1736	1619	1513	1419	1333	1257	1187	1125	0.228
	8	1948	1820	1704	1597	1501	1414	1335	1264	1199	0.207
	9	2022	1897	1782	1676	1579	1491	1410	1337	1270	0.189
10	2090	1968	1854	1749	1652	1563	1482	1407	1338	0.175	
30/3 Dxx* F = 1453	0	755	676	603	544	494	452	416	384	357	1.167
	1	897	816	747	683	622	570	526	487	453	0.766
	2	1022	937	863	798	742	689	636	590	550	0.571
	3	1132	1045	968	899	839	786	738	692	646	0.454
	4	1227	1140	1062	992	929	873	822	776	735	0.378
	5	1310	1225	1147	1076	1012	954	901	853	809	0.323
	6	1381	1299	1223	1152	1088	1029	974	925	879	0.282
	7	1442	1364	1290	1221	1157	1097	1042	992	945	0.250
	8	1494	1420	1350	1283	1220	1161	1105	1054	1007	0.225
	9	1540	1470	1403	1338	1276	1218	1164	1112	1065	0.205
10	1579	1514	1450	1388	1328	1271	1217	1166	1119	0.187	

Shaded Area does not conform to SDI maximum fastener spacing of 36" o.c. for spans greater than 5' 0".

* D_{xx} is a warping factor dependent on the end fastener pattern and used in the equation for G' .

Values to the right of bold line may exceed the maximum recommended spans.

Deck Profile	Nominal Shear Strength due to Panel Buckling (S_{nb}), PLF								$\Omega_b = 2, \phi_b = .8$	
	4.0	4.5	5.0	5.5	6.0	6.5	7.0	7.5		8.0
F20	3923	3099	2510	2075	1743	1485	1281	1116	981	

$$G' = \frac{K_2}{K_4 + 0.3D_{xx}/L_v + 3K_1L_v} \text{ (kips/in)}$$

F Deck
 $K_2 = 1056$
 $K_4 = 3.78$

Design Notes:

Choose more severe factored resistance:

LRFD lesser of $\phi_b S_{nb}$ and ϕS_n

ASD lesser of S_{nb}/Ω_b and S_n/Ω

If load = wind, see interaction calculator on web.



ROOF DECK - Weld Screw

B, F Deck 18 gage Diaphragm Tables $F_y = 40$ ksi

Fastener Support 5/8" ϕ puddle welds
Side-Lap #10 screw

Strength/Fast.
 $Q_r = 3132$ lb.
 $Q_s = 1019$ lb.

Load	Ω	ϕ
Seismic	3.00	0.55
Wind	2.35	0.70
Other	2.65	0.60

Fastener Pattern	Side-Lap Conn./Span	Nominal Shear Strength (S_n), PLF									K1
		Span (L_v), Ft.									
		5.0	5.5	6.0	6.5	7.0	7.5	8.0	8.5	9.0	
36/7 Dxx* B = 63 F = 111	0	1240	1122	1023	940	868	806	752	705	662	0.615
	1	1443	1307	1193	1097	1014	942	880	824	775	0.478
	2	1647	1492	1363	1253	1160	1078	1007	944	889	0.391
	3	1828	1674	1533	1410	1305	1214	1134	1064	1002	0.330
	4	2004	1838	1697	1567	1451	1350	1262	1184	1115	0.286
	5	2175	1998	1846	1715	1596	1486	1389	1304	1228	0.253
	6	2340	2153	1993	1854	1732	1622	1517	1424	1341	0.226
	7	2500	2305	2136	1989	1860	1746	1644	1544	1455	0.204
	8	2654	2451	2275	2121	1985	1865	1758	1662	1568	0.187
	9	2803	2593	2411	2250	2108	1982	1869	1769	1678	0.172
10	2946	2731	2542	2376	2228	2097	1979	1874	1778	0.159	
36/5 Dxx* B = 372 F = 435	0	1146	1036	945	868	802	744	694	650	610	0.738
	1	1336	1222	1115	1025	947	880	821	769	723	0.549
	2	1505	1384	1280	1181	1093	1016	949	889	837	0.437
	3	1666	1536	1424	1326	1238	1152	1076	1009	950	0.363
	4	1819	1682	1562	1457	1365	1282	1203	1129	1063	0.310
	5	1964	1820	1695	1584	1485	1398	1319	1249	1176	0.271
	6	2100	1952	1821	1705	1602	1510	1427	1352	1284	0.241
	7	2227	2076	1942	1822	1715	1618	1531	1452	1380	0.216
	8	2346	2194	2057	1934	1823	1723	1632	1549	1474	0.196
	9	2458	2305	2166	2040	1927	1823	1730	1644	1566	0.180
10	2562	2409	2269	2142	2026	1920	1824	1736	1655	0.166	
36/4 Dxx* B = 526 F = 597	0	869	784	714	654	603	559	521	486	456	0.923
	1	1065	970	884	811	749	695	648	606	569	0.645
	2	1229	1133	1049	968	895	831	775	726	683	0.496
	3	1382	1278	1188	1108	1038	967	903	846	796	0.403
	4	1524	1415	1318	1233	1158	1090	1029	966	909	0.339
	5	1654	1541	1441	1352	1272	1200	1135	1076	1022	0.293
	6	1774	1659	1556	1463	1380	1304	1236	1173	1117	0.257
	7	1883	1768	1663	1568	1482	1404	1332	1267	1207	0.230
	8	1982	1868	1763	1667	1579	1498	1425	1357	1295	0.207
	9	2072	1960	1855	1759	1670	1588	1512	1443	1378	0.189
10	2154	2044	1941	1845	1755	1672	1596	1525	1459	0.174	

Shaded Area does not conform to SDI maximum fastener spacing of 36" o.c. for spans greater than 5' 0".

* Dxx is a warping factor dependent on the end fastener pattern and used in the equation for G'.

Values to the right of bold line may exceed the maximum recommended spans.

Deck Profile	Nominal Shear Strength due to Panel Buckling (S_{nb}), PLF									$\Omega_b = 2, \phi_b = .8$	
	5.0	5.5	6.0	6.5	7.0	7.5	8.0	8.5	9.0		
F18	4200	3471	2917	2485	2143	1867	1641	1453	1296		
B18	4824	3987	3350	2854	2461	2144	1884	1669	1489		

$$G' = \frac{K_2}{K_4 + 0.3D_{xx}/L_v + 3K_1L_v} \text{ (kips/in)}$$

B & F Deck
 $K_2 = 1398$
 $K_4 = 3.78$

Design Notes:

Choose more severe factored resistance:

LRFD lesser of $\phi_b S_{nb}$ and ϕS_n

ASD lesser of S_{nb}/Ω_b and S_n/Ω

If load = wind, see interaction calculator on web.



ROOF DECK - Weld Screw

F Deck 18 gage Diaphragm Tables $F_y = 40$ ksi

Fastener Support 5/8" ϕ puddle welds
Side-Lap #10 screw

Strength/Fast.
 $Q_t = 3132$ lb.
 $Q_b = 1019$ lb.

Load	Ω	ϕ
Seismic	3.00	0.55
Wind	2.35	0.70
Other	2.65	0.60

Nominal Shear Strength (S_n), PLF

Fastener Pattern	Side-Lap Conn./Span	Span (L_v), Ft.								K1	
		5.0	5.5	6.0	6.5	7.0	7.5	8.0	8.5		9.0
30/6 D_{xx}^* F = 111	0	1109	1003	914	840	775	720	671	628	590	0.821
	1	1313	1188	1084	996	921	855	798	748	703	0.622
	2	1517	1374	1254	1153	1066	991	926	868	816	0.501
	3	1713	1559	1424	1310	1212	1127	1053	988	929	0.419
	4	1892	1734	1594	1467	1358	1263	1180	1107	1043	0.360
	5	2066	1896	1751	1623	1503	1399	1308	1227	1156	0.316
	6	2235	2054	1900	1766	1649	1535	1435	1347	1269	0.281
	7	2398	2208	2045	1903	1778	1668	1563	1467	1382	0.254
	8	2556	2358	2186	2037	1905	1789	1685	1587	1496	0.231
	9	2708	2503	2324	2168	2030	1907	1798	1701	1609	0.212
10	2855	2644	2458	2296	2152	2024	1909	1807	1714	0.196	
30/4 D_{xx}^* F = 760	0	1076	973	887	814	751	697	650	608	571	0.923
	1	1262	1158	1056	971	897	833	777	728	684	0.679
	2	1428	1315	1217	1127	1043	969	905	848	798	0.537
	3	1584	1463	1358	1266	1185	1105	1032	968	911	0.444
	4	1732	1604	1492	1394	1307	1229	1160	1088	1024	0.379
	5	1869	1737	1620	1517	1424	1342	1268	1201	1137	0.330
	6	1998	1863	1742	1634	1537	1451	1372	1302	1237	0.293
	7	2117	1980	1857	1746	1646	1555	1473	1399	1331	0.263
	8	2228	2090	1965	1852	1749	1656	1571	1493	1423	0.238
	9	2330	2193	2067	1952	1848	1752	1664	1584	1511	0.218
10	2425	2289	2163	2048	1941	1844	1754	1672	1596	0.201	
30/3 D_{xx}^* F = 954	0	792	715	650	595	549	508	473	441	413	1.343
	1	973	896	820	752	694	644	600	561	527	0.882
	2	1125	1041	968	904	840	780	727	681	640	0.657
	3	1264	1175	1097	1027	965	909	855	801	753	0.523
	4	1388	1297	1215	1142	1076	1016	962	913	866	0.434
	5	1499	1407	1324	1248	1179	1117	1060	1008	960	0.372
	6	1598	1507	1423	1346	1276	1211	1152	1097	1047	0.325
	7	1686	1597	1513	1436	1365	1299	1238	1182	1130	0.288
	8	1764	1677	1595	1519	1447	1381	1319	1262	1208	0.259
	9	1832	1749	1669	1594	1523	1457	1395	1337	1282	0.235
10	1893	1813	1736	1663	1593	1527	1465	1407	1352	0.216	

Shaded Area does not conform to SDI maximum fastener spacing of 36" o.c. for spans greater than 5' 0".

* D_{xx} is a warping factor dependent on the end fastener pattern and used in the equation for G' .

Values to the right of bold line may exceed maximum recommended spans.

Deck Profile	Nominal Shear Strength due to Panel Buckling (S_{nb}), PLF									$\Omega_b = 2, \phi_b = .8$
	5.0	5.5	6.0	6.5	7.0	7.5	8.0	8.5	9.0	
F18	4200	3471	2917	2485	2143	1867	1641	1453	1296	

$$G' = \frac{K_2}{K_4 + 0.3D_{xx}/L_v + 3K_1L_v} \text{ (kips/in)}$$

F Deck
 $K_2 = 1398$
 $K_4 = 3.78$

Design Notes:

Choose more severe factored resistance:

LRFD lesser of $\phi_b S_{nb}$ and ϕS_n

ASD lesser of S_{nb}/Ω_b and S_n/Ω

If load = wind, see interaction calculator on web.



ROOF DECK - Weld Screw

B Deck 16 gage Diaphragm Tables $F_y = 40$ ksi

Fastener Support 5/8" ϕ puddle welds
Side-Lap #10 screw

Strength/Fast.
 $Q_f = 3867$ lb.
 $Q_s = 1286$ lb.

Load	Ω	ϕ
Seismic	3.00	0.55
Wind	2.35	0.70
Other	2.65	0.60

Fastener Pattern	Side-Lap Conn./Span	Nominal Shear Strength (S_n), PLF									K1
		Span (L_v), Ft.									
		6.0	6.5	7.0	7.5	8.0	8.5	9.0	9.5	10.0	
36/7 Dxx* B = 45	0	1271	1168	1080	1004	937	878	825	779	736	0.691
	1	1485	1366	1264	1175	1098	1029	968	914	865	0.537
	2	1700	1564	1447	1347	1258	1180	1111	1049	993	0.439
	3	1914	1762	1631	1518	1419	1332	1254	1185	1122	0.371
	4	2111	1959	1815	1689	1580	1483	1397	1320	1251	0.322
	5	2299	2137	1995	1861	1740	1634	1540	1455	1379	0.284
	6	2484	2310	2159	2025	1901	1785	1683	1591	1508	0.254
	7	2663	2480	2320	2178	2051	1937	1825	1726	1636	0.229
	8	2838	2646	2478	2328	2194	2075	1967	1861	1765	0.209
	9	3008	2809	2632	2475	2335	2209	2096	1993	1893	0.193
10	3173	2966	2783	2619	2473	2341	2222	2114	2016	0.178	
36/5 Dxx* B = 262	0	1175	1079	998	927	865	810	761	718	679	0.829
	1	1389	1277	1181	1098	1025	961	904	853	807	0.617
	2	1588	1475	1365	1270	1186	1112	1047	988	936	0.491
	3	1769	1647	1541	1441	1347	1264	1190	1124	1064	0.408
	4	1943	1813	1698	1596	1505	1415	1333	1259	1193	0.349
	5	2110	1972	1850	1741	1644	1556	1476	1394	1321	0.304
	6	2269	2125	1996	1882	1778	1685	1601	1524	1450	0.270
	7	2420	2271	2138	2018	1909	1811	1722	1641	1567	0.243
	8	2564	2411	2273	2149	2036	1934	1840	1755	1677	0.221
	9	2700	2544	2403	2275	2158	2052	1955	1866	1784	0.202
10	2829	2671	2528	2396	2277	2167	2066	1974	1889	0.186	
36/4 Dxx* B = 371	0	890	816	753	699	651	609	571	538	507	1.037
	1	1104	1014	937	870	811	760	714	673	636	0.725
	2	1303	1212	1120	1041	972	911	857	808	765	0.557
	3	1477	1378	1291	1213	1133	1062	1000	944	893	0.452
	4	1641	1536	1442	1358	1283	1214	1143	1079	1022	0.381
	5	1795	1684	1585	1495	1415	1342	1276	1214	1150	0.329
	6	1939	1824	1720	1627	1542	1464	1394	1329	1270	0.289
	7	2073	1955	1849	1751	1663	1582	1507	1439	1377	0.258
	8	2197	2078	1969	1870	1778	1694	1617	1546	1480	0.233
	9	2312	2193	2083	1981	1888	1801	1722	1648	1579	0.212
10	2418	2299	2189	2087	1992	1904	1822	1746	1675	0.195	

Shaded Area does not conform to SDI maximum fastener spacing of 36" o.c. for spans greater than 5' 0".

* Dxx is a warping factor dependent on the end fastener pattern and used in the equation for G'.

Deck Profile	Nominal Shear Strength due to Panel Buckling (S_{nb}), PLF									$\Omega_b = 2, \phi_b = .8$	
	6.0	6.5	7.0	7.5	8.0	8.5	9.0	9.5	10.0		
B16	4884	4162	3588	3126	2747	2434	2171	1948	1758		

$$G' = \frac{K_2}{K_4 + 0.3D_{xx}/L_v + 3K_1L_v} \text{ (kips/in)}$$

B Deck
 $K_2 = 1764$
 $K_4 = 3.78$

Design Notes:

Choose more severe factored resistance:

LRFD lesser of $\phi_b S_{nb}$ and ϕS_n

ASD lesser of S_{nb}/Ω_b and S_n/Ω

If load = wind, see interaction calculator on web.

ROOF DECK - Weld Screw

N Deck 22 & 20 gage Diaphragm Tables $F_y = 40$ ksi

Fastener Support 5/8" ϕ puddle welds
Side-Lap #10 screws

Load	Ω	ϕ
Seismic	3.00	0.55
Wind	2.35	0.70
Other	2.65	0.60

Nominal Shear Strength (S_n), PLF 22 ga. design thickness (t)=0.0295 in.
Strength/Fast. $Q_t = 2010$ lb. $Q_s = 634$ lb.

Fastener Pattern	Side-Lap Conn./Span	Span (L_v), Ft.								K1	
		8.0	8.5	9.0	9.5	10.0	10.5	11.0	11.5		12.0
24/4	0	322	303	286	271	258	246	234	224	215	1.093
	2	481	453	427	405	385	366	350	334	321	0.587
	3	560	527	498	472	448	427	407	390	373	0.476
	4	639	602	568	538	511	487	465	445	426	0.401
	5	719	676	639	605	575	548	523	500	479	0.346
	6	798	751	709	672	638	608	580	555	532	0.305
Dxx [*] N = 653	7	877	826	780	739	702	668	638	610	585	0.272
	8	955	900	850	805	765	729	696	665	638	0.246
	9	1022	968	919	872	829	789	753	721	691	0.224
	10	1087	1031	980	933	891	850	811	776	743	0.206
	11	1150	1092	1039	990	945	905	867	831	796	0.190

Nominal Shear Strength (S_n), PLF 20 ga. design thickness (t)=0.0358 in.
Strength/Fast. $Q_t = 2413$ lb. $Q_s = 770$ lb.

Fastener Pattern	Side-Lap Conn./Span	Span (L_v), Ft.								K1	
		9.0	9.5	10.0	10.5	11.0	11.5	12.0	12.5		13.0
24/4	0	344	326	310	295	281	269	258	248	238	1.204
	3	600	569	540	515	491	470	450	432	416	0.525
	4	686	650	617	588	561	537	514	494	475	0.442
	5	772	731	694	661	631	604	579	555	534	0.381
	6	857	812	771	735	701	671	643	617	593	0.336
	7	943	893	848	808	771	738	707	679	653	0.300
Dxx [*] N=488	8	1028	974	925	881	841	805	771	740	712	0.270
	9	1111	1055	1002	955	911	872	835	802	771	0.247
	10	1184	1128	1076	1028	981	938	899	863	830	0.227
	11	1255	1197	1143	1093	1048	1005	963	925	889	0.210
	12	1325	1264	1208	1156	1109	1065	1024	986	949	0.195

Shaded Area does not conform to SDI maximum fastener spacing of 36" o.c. for spans greater than 5' 0".

* D_{xx} is a warping factor dependent on the end fastener pattern and used in the equation for G' .

Deck Profile	Nominal Shear Strength due to Panel Buckling (S_{nb}), PLF	$\Omega_b = 2, \phi_b = .8$										
		K_2	8.0	8.5	9.0	9.5	10.0	10.5	11.0	11.5	12.0	12.5
N22	870	2205	1953	1742	1564	1411	1280	1166	1067	980		
N20	1056			2445	2195	1981	1797	1637	1498	1376	1268	1172

$$G' = \frac{K_2}{K_4 + 0.3D_{xx}/L_v + 3K_1L_v} \text{ (kips/in)}$$

N Deck $K_4 = 4.31$

Design Notes:

Choose more severe factored resistance:

LRFD lesser of $\phi_b S_{nb}$ and ϕS_n

ASD lesser of S_{nb}/Ω_b and S_n/Ω

If load = wind, see interaction calculator on web.



ROOF DECK - Weld Screw

N Deck 18 & 16 gage Diaphragm Tables $F_y = 40$ ksi

Fastener Support 5/8" ϕ puddle welds
Side-Lap #10 screws

Load	Ω	ϕ
Seismic	3.00	0.55
Wind	2.35	0.70
Other	2.65	0.60

Nominal Shear Strength (S_n), PLF 18 ga. design thickness (t)=0.0474 in.

Fastener Pattern	Side-Lap Conn./Span	Span (L_v), Ft.									K1
		10.0	10.5	11.0	11.5	12.0	12.5	13.0	13.5	14.0	
24/4	0	402	383	365	349	335	321	309	298	287	1.385
	3	707	674	643	615	590	566	544	524	505	0.604
	4	809	771	736	704	674	648	623	600	578	0.508
	5	911	868	828	792	759	729	701	675	651	0.439
	6	1013	965	921	881	844	811	779	751	724	0.386
	7	1115	1062	1014	970	929	892	858	826	797	0.345
	Dxx*	8	1217	1159	1106	1058	1014	974	936	901	869
N = 321	9	1319	1256	1199	1147	1099	1055	1015	977	942	0.284
	10	1415	1353	1292	1236	1184	1137	1093	1052	1015	0.261
	11	1502	1437	1378	1323	1269	1218	1171	1128	1088	0.241
	12	1588	1520	1458	1401	1347	1297	1250	1203	1160	0.224
	13	1672	1602	1537	1477	1421	1369	1321	1276	1233	0.210

Nominal Shear Strength (S_n), PLF 16 ga. design thickness (t)=0.0598 in.

Fastener Pattern	Side-Lap Conn./Span	Span (L_v), Ft.								K1	
		11.0	11.5	12.0	12.5	13.0	13.5	14.0	14.5		15.0
24/4	0	451	431	413	397	382	367	354	342	331	1.556
	3	802	767	735	705	678	653	630	608	588	0.678
	4	918	878	842	808	777	748	722	697	673	0.571
	5	1035	990	949	911	876	844	813	785	759	0.493
	6	1152	1102	1056	1014	975	939	905	874	845	0.434
	7	1269	1214	1163	1117	1074	1034	997	963	931	0.387
	Dxx*	8	1386	1326	1270	1220	1173	1129	1089	1051	1016
N=226	9	1503	1437	1378	1322	1272	1225	1181	1140	1102	0.319
	10	1620	1549	1485	1425	1371	1320	1273	1229	1188	0.293
	11	1725	1656	1592	1528	1469	1415	1364	1317	1273	0.271
	12	1826	1754	1687	1625	1567	1510	1456	1406	1359	0.252
	13	1925	1850	1780	1715	1655	1598	1545	1495	1445	0.235

Shaded Area does not conform to SDI maximum fastener spacing of 36" o.c. for spans greater than 5' 0".

* D_{xx} is a warping factor dependent on the end fastener pattern and used in the equation for G'.

Tables are based on 3 span conditions. Values to the right of double lines exceed practical production limits. Use 2 span conditions. At 2 span strengths are generally higher and stiffness reduction is less than 19% of the table values.

Deck Profile	K ₂	Nominal Shear Strength due to Panel Buckling (S_{nb}), PLF										$\Omega_b = 2, \phi_b = .8$	
		10.0	10.5	11.0	11.5	12.0	12.5	13.0	13.5	14.0	14.5	15.0	
N18	1398	3206	2908	2649	2424	2226	2052	1897	1759	1636			
N16	1764			3990	3651	3353	3090	2857	2649	2463	2296	2146	

$$G' = \frac{K_2}{K_4 + 0.3D_{xx}/L_v + 3K_1L_v} \text{ (kips/in)}$$

N Deck
K₄ = 4.31

Design Notes:

Choose more severe factored resistance:

LRFD lesser of $\phi_b S_{nb}$ and ϕS_n

ASD lesser of S_{nb}/Ω_b and S_n/Ω

If load = wind, see interaction calculator on web.



ROOF DECK - Screw Screw

B, F Deck 22 gage Diaphragm Tables F_y = 40 ksi

Fastener Support #12 or #14 screw
Side-Lap #10 screw

Strength/Fast.
Q_r = 1180 lb.
Q_s = 634 lb.

Load	Ω	φ
Seismic	2.50	0.65
Wind	2.35	0.70
Other	2.50	0.65

Fastener Pattern	Side-Lap Conn./Span	Nominal Shear Strength (S _n), PLF									K1
		Span (L _v), Ft.									
		3.0	3.5	4.0	4.5	5.0	5.5	6.0	6.5	7.0	
36/7 Dxx* B = 129 F = 226	0	771	671	583	515	461	416	379	348	321	0.549
	1	942	825	733	656	588	532	485	446	412	0.414
	2	1097	968	865	780	709	647	591	543	502	0.333
	3	1236	1100	988	895	816	750	693	641	593	0.278
	4	1359	1219	1102	1003	918	846	784	729	682	0.239
	5	1467	1327	1207	1104	1015	938	871	812	760	0.209
	6	1562	1425	1303	1197	1105	1024	953	891	836	0.186
	7	1646	1511	1391	1284	1190	1106	1032	967	908	0.168
	8	1719	1589	1471	1364	1269	1183	1107	1039	978	0.152
	9	1782	1658	1543	1437	1342	1256	1178	1108	1045	0.140
10	1838	1720	1608	1505	1410	1323	1245	1173	1109	0.129	
36/5 Dxx* B = 758 F = 886	0	682	600	534	476	426	384	350	321	296	0.659
	1	825	734	660	597	545	500	456	418	387	0.474
	2	944	851	771	704	646	596	552	515	477	0.370
	3	1042	950	870	799	737	684	636	595	558	0.304
	4	1123	1035	955	884	821	764	714	669	630	0.257
	5	1188	1106	1029	959	895	838	786	739	697	0.223
	6	1242	1166	1093	1025	962	904	852	804	760	0.197
	7	1287	1216	1148	1082	1021	964	912	863	819	0.177
	8	1323	1259	1195	1133	1074	1018	966	918	873	0.160
	9	1354	1295	1235	1177	1120	1066	1016	968	923	0.146
10	1380	1325	1270	1215	1162	1110	1060	1014	969	0.134	
36/4 Dxx* B = 1072 F = 1216	0	523	460	409	360	321	289	263	241	221	0.824
	1	659	590	532	483	442	405	369	338	312	0.554
	2	766	696	636	583	537	498	463	432	403	0.417
	3	847	782	722	669	621	579	541	507	477	0.334
	4	910	850	793	741	694	650	611	576	544	0.279
	5	958	904	852	802	756	713	673	637	604	0.240
	6	995	947	899	853	809	767	728	692	659	0.210
	7	1024	982	938	896	854	814	777	741	708	0.187
	8	1047	1009	970	931	893	855	819	784	752	0.168
	9	1066	1032	997	961	925	890	856	823	791	0.153
10	1081	1051	1019	987	953	921	888	856	826	0.140	

Shaded Area does not conform to SDI maximum fastener spacing of 36" o.c. for spans greater than 5' 0".

* Dxx is a warping factor dependent on the end fastener pattern and used in the equation for G'.

Values to the right of bold line may exceed the maximum recommended spans.

Deck Profile	Nominal Shear Strength due to Panel Buckling (S _{nb}), PLF									Ω _b = 2, φ _b = .8	
	3.0	3.5	4.0	4.5	5.0	5.5	6.0	6.5	7.0		
F22	5161	3792	2903	2294	1858	1536	1290	1099	948		
B22	6011	4416	3381	2671	2164	1788	1503	1280	1104		

$$G' = \frac{K_2}{K_4 + 0.3D_{xx}/L_v + 3K_1L_v} \text{ (kips/in)}$$

B & F Deck
K₂ = 870
K₄ = 3.78

Design Notes:

Choose more severe factored resistance:

LRFD lesser of φ_bS_{nb} and φS_n

ASD lesser of S_{nb}/Ω_b and S_n/Ω

If load = wind, see interaction calculator on web.

TABLES



ROOF DECK - Screw Screw

F Deck 22 gage Diaphragm Tables $F_y = 40$ ksi

Fastener Support #12 or #14 screw
Side-Lap #10 screw

Strength/Fast.
 $Q_t = 1180$ lb.
 $Q_s = 634$ lb.

Load	Ω	ϕ
Seismic	2.50	0.65
Wind	2.35	0.70
Other	2.50	0.65

Nominal Shear Strength (S_n), PLF

Fastener Pattern	Side-Lap Conn./Span	Span (L_v), Ft.								K1	
		3.0	3.5	4.0	4.5	5.0	5.5	6.0	6.5		7.0
30/6 Dxx* F = 226	0	701	601	522	461	412	372	338	310	286	0.732
	1	878	767	679	602	539	487	444	408	377	0.538
	2	1039	914	814	733	666	602	550	505	467	0.425
	3	1184	1050	941	851	775	712	656	603	558	0.351
	4	1313	1175	1059	962	880	809	749	697	648	0.299
	5	1427	1287	1168	1066	978	903	837	780	730	0.261
	6	1527	1388	1267	1162	1071	991	922	861	807	0.231
	7	1615	1479	1358	1251	1158	1075	1002	938	880	0.207
	8	1691	1560	1441	1334	1239	1154	1079	1011	951	0.188
	9	1759	1632	1516	1410	1314	1228	1151	1082	1019	0.172
10	1817	1697	1584	1479	1384	1298	1219	1148	1084	0.159	
30/4 Dxx* F = 1547	0	637	561	500	447	399	360	328	301	277	0.823
	1	774	692	623	565	517	475	434	398	368	0.585
	2	886	802	730	668	614	568	527	492	458	0.454
	3	976	895	823	759	702	652	608	569	535	0.371
	4	1048	972	902	838	780	729	683	641	604	0.314
	5	1106	1035	969	907	850	798	751	708	669	0.272
	6	1152	1088	1025	966	911	859	812	768	728	0.240
	7	1190	1131	1073	1017	964	914	867	823	783	0.214
	8	1220	1167	1114	1061	1011	962	916	873	833	0.194
	9	1245	1197	1148	1099	1051	1005	961	919	879	0.177
10	1266	1223	1178	1132	1087	1043	1000	960	921	0.163	
30/3 Dxx* F = 1943	0	465	412	369	328	292	263	239	218	201	1.198
	1	585	530	481	440	405	374	345	316	291	0.753
	2	672	619	572	529	491	457	427	400	376	0.549
	3	734	687	642	601	563	528	497	468	443	0.432
	4	779	738	698	659	623	589	557	528	501	0.356
	5	812	776	741	705	671	639	609	580	553	0.303
	6	836	806	774	742	711	681	652	624	598	0.263
	7	855	828	801	772	744	716	689	662	637	0.233
	8	869	846	822	797	771	745	720	695	671	0.209
	9	880	860	839	816	793	770	746	723	700	0.190
10	889	872	853	833	812	790	769	747	726	0.173	

Shaded Area does not conform to SDI maximum fastener spacing of 36" o.c. for spans greater than 5' 0".

* D_{xx} is a warping factor dependent on the end fastener pattern and used in the equation for G' .

Values to the right of bold line may exceed the maximum recommended spans.

Deck Profile	Nominal Shear Strength due to Panel Buckling (S_{nb}), PLF								$\Omega_b = 2, \phi_b = .8$
	3.0	3.5	4.0	4.5	5.0	5.5	6.0	6.5	7.0
F22	5161	3792	2903	2294	1858	1536	1290	1099	948

$$G' = \frac{K_2}{K_4 + 0.3D_{xx}/L_v + 3K_1L_v} \text{ (kips/in)}$$

F Deck
 $K_2 = 870$
 $K_4 = 3.78$

Design Notes:

Choose more severe factored resistance:

LRFD lesser of $\phi_b S_{nb}$ and ϕS_n

ASD lesser of S_{nb}/Ω_b and S_n/Ω

If load = wind, see interaction calculator on web.

DIAPHRAGM



ROOF DECK - Screw Screw

B, F Deck 20 gage Diaphragm Tables $F_y = 40$ ksi

Fastener Support #12 or #14 screw
Side-Lap #10 screw

Strength/Fast.
 $Q_r = 1432$ lb.
 $Q_s = 770$ lb.

Load	Ω	ϕ
Seismic	2.50	0.65
Wind	2.35	0.70
Other	2.50	0.65

Fastener Pattern	Side-Lap Conn./Span	Nominal Shear Strength (S_n), PLF									K1
		Span (L_v), Ft.									
		4.0	4.5	5.0	5.5	6.0	6.5	7.0	7.5	8.0	
36/7 Dxx* B = 97 F = 169	0	711	629	563	509	464	426	393	365	340	0.605
	1	889	798	717	649	592	544	503	467	436	0.456
	2	1049	946	860	788	720	662	613	570	532	0.366
	3	1199	1086	991	910	841	781	723	672	628	0.306
	4	1337	1217	1115	1027	951	885	827	775	725	0.263
	5	1465	1339	1231	1138	1056	985	922	867	817	0.230
	6	1582	1453	1341	1243	1157	1081	1014	954	901	0.205
	7	1688	1558	1444	1342	1253	1173	1102	1039	982	0.185
	8	1785	1655	1540	1436	1344	1261	1187	1120	1060	0.168
	9	1872	1744	1628	1524	1430	1345	1268	1199	1136	0.154
10	1952	1826	1711	1606	1511	1424	1345	1274	1209	0.142	
36/5 Dxx* B = 567 F = 663	0	648	581	520	470	428	393	362	336	313	0.725
	1	800	725	662	608	556	511	472	439	409	0.522
	2	936	854	784	723	670	625	582	541	506	0.408
	3	1055	970	895	830	772	722	677	637	601	0.334
	4	1159	1073	996	927	867	812	764	721	681	0.283
	5	1249	1164	1086	1017	954	897	846	800	758	0.246
	6	1326	1243	1167	1097	1033	975	922	874	830	0.217
	7	1393	1313	1239	1170	1106	1048	994	944	898	0.195
	8	1450	1375	1303	1236	1172	1114	1059	1009	962	0.176
	9	1499	1428	1360	1294	1233	1174	1120	1070	1022	0.161
10	1541	1475	1410	1347	1287	1230	1176	1126	1078	0.148	
36/4 Dxx* B = 802 F = 909	0	498	440	393	354	322	295	272	252	234	0.907
	1	646	586	536	494	451	414	382	354	330	0.610
	2	771	708	652	604	562	524	491	457	426	0.459
	3	876	812	754	702	657	616	579	546	517	0.368
	4	963	899	842	789	742	699	660	624	592	0.307
	5	1033	973	917	865	817	773	733	696	662	0.264
	6	1091	1035	982	931	884	840	799	761	726	0.231
	7	1139	1087	1037	988	942	899	859	821	785	0.206
	8	1178	1130	1083	1038	994	952	912	874	839	0.185
	9	1210	1167	1123	1080	1039	998	960	923	888	0.168
10	1237	1197	1157	1117	1078	1039	1002	966	932	0.154	

Shaded Area does not conform to SDI maximum fastener spacing of 36" o.c. for spans greater than 5' 0".

* Dxx is a warping factor dependent on the end fastener pattern and used in the equation for G'.

Values to the right of bold line may exceed the maximum recommended spans.

Deck Profile	Nominal Shear Strength due to Panel Buckling (S_{nb}), PLF									$\Omega_b = 2, \phi_b = .8$
	4.0	4.5	5.0	5.5	6.0	6.5	7.0	7.5	8.0	
F20	3923	3099	2510	2075	1743	1485	1281	1116	981	
B20	4621	3652	2958	2444	2054	1750	1509	1315	1155	

$$G' = \frac{K_2}{K_4 + 0.3D_{xx}/L_v + 3K_1L_v} \text{ (kips/in)}$$

B & F Deck
 $K_2 = 1056$
 $K_4 = 3.78$

Design Notes:

Choose more severe factored resistance:

LRFD lesser of $\phi_b S_{nb}$ and ϕS_n

ASD lesser of S_{nb}/Ω_b and S_n/Ω

If load = wind, see interaction calculator on web.



ROOF DECK - Screw Screw

F Deck 20 gage Diaphragm Tables $F_y = 40$ ksi

Fastener Support #12 or #14 screw
Side-Lap #10 screw

Strength/Fast.
 $Q_t = 1432$ lb.
 $Q_s = 770$ lb.

Load	Ω	ϕ
Seismic	2.50	0.65
Wind	2.35	0.70
Other	2.50	0.65

Fastener Pattern	Side-Lap Conn./Span	Nominal Shear Strength (S_n), PLF								K1	
		Span (L_v), Ft.									
		4.0	4.5	5.0	5.5	6.0	6.5	7.0	7.5	8.0	
30/6 Dxx* F = 169	0	637	562	503	454	414	380	350	325	303	0.806
	1	824	734	657	594	542	498	460	428	399	0.592
	2	988	890	808	734	671	617	570	530	495	0.468
	3	1142	1033	941	864	798	735	680	633	591	0.387
	4	1285	1167	1067	982	909	845	790	735	687	0.330
	5	1417	1293	1187	1096	1016	947	886	832	784	0.287
	6	1538	1410	1300	1203	1119	1044	979	921	868	0.255
	7	1648	1519	1405	1305	1216	1138	1068	1006	951	0.229
	8	1748	1619	1503	1401	1309	1227	1154	1089	1030	0.207
	9	1840	1711	1595	1491	1397	1313	1237	1169	1107	0.190
10	1922	1795	1680	1575	1480	1394	1316	1245	1181	0.175	
30/4 Dxx* F = 1157	0	607	546	488	441	401	368	339	315	293	0.907
	1	756	686	627	577	530	486	449	417	389	0.645
	2	886	810	745	689	640	597	559	520	485	0.500
	3	998	921	852	792	738	691	649	611	578	0.409
	4	1094	1017	947	885	829	778	733	693	656	0.346
	5	1175	1100	1031	968	911	859	812	769	729	0.299
	6	1244	1172	1105	1043	985	932	884	839	799	0.264
	7	1302	1234	1170	1109	1052	999	950	905	863	0.236
	8	1352	1288	1226	1168	1112	1060	1011	966	923	0.213
	9	1393	1334	1276	1220	1166	1115	1067	1021	979	0.195
10	1429	1374	1319	1266	1214	1165	1117	1072	1030	0.179	
30/3 Dxx* F = 1453	0	448	401	358	323	293	268	247	228	212	1.319
	1	584	534	491	454	421	386	357	331	308	0.829
	2	694	642	596	555	518	486	457	431	404	0.605
	3	780	729	683	641	603	569	537	509	483	0.476
	4	847	800	756	714	676	641	608	578	551	0.392
	5	899	856	815	776	738	704	671	641	612	0.334
	6	939	901	863	827	791	758	726	696	667	0.290
	7	972	937	903	869	836	804	773	744	716	0.257
	8	997	967	936	904	874	844	814	786	759	0.230
	9	1018	991	963	934	906	878	850	823	797	0.209
10	1035	1010	985	959	933	907	881	855	830	0.191	

Shaded Area does not conform to SDI maximum fastener spacing of 36" o.c. for spans greater than 5' 0".

* D_{xx} is a warping factor dependent on the end fastener pattern and used in the equation for G' .

Values to the right of bold line may exceed the maximum recommended spans.

Deck Profile	Nominal Shear Strength due to Panel Buckling (S_{nb}), PLF								$\Omega_b = 2, \phi_b = .8$
	4.0	4.5	5.0	5.5	6.0	6.5	7.0	7.5	8.0
F20	3923	3099	2510	2075	1743	1485	1281	1116	981

$$G' = \frac{K_2}{K_4 + 0.3D_{xx}/L_v + 3K_1L_v} \text{ (kips/in)}$$

F Deck
 $K_2 = 1056$
 $K_4 = 3.78$

Design Notes:

Choose more severe factored resistance:

LRFD lesser of $\phi_b S_{nb}$ and ϕS_n

ASD lesser of S_{nb}/Ω_b and S_n/Ω

If load = wind, see interaction calculator on web.



ROOF DECK - Screw Screw

B, F Deck 18 gage Diaphragm Tables $F_y = 40$ ksi

Fastener Support #12 or #14 screw
Side-Lap #10 screw

Strength/Fast.
 $Q_r = 1896$ lb.
 $Q_s = 1019$ lb.

Load	Ω	ϕ
Seismic	2.50	0.65
Wind	2.35	0.70
Other	2.50	0.65

Fastener Pattern	Side-Lap Conn./Span	Nominal Shear Strength (S_n), PLF									K1
		Span (L_v), Ft.									
		5.0	5.5	6.0	6.5	7.0	7.5	8.0	8.5	9.0	
36/7 Dxx* B = 63 F = 111	0	750	679	619	569	526	488	455	426	401	0.696
	1	954	864	789	726	671	624	583	546	514	0.525
	2	1139	1044	959	882	817	760	710	666	627	0.422
	3	1312	1205	1114	1035	962	896	838	786	740	0.352
	4	1476	1360	1259	1172	1095	1028	965	906	854	0.303
	5	1630	1507	1399	1304	1221	1147	1082	1023	967	0.265
	6	1776	1646	1532	1431	1342	1263	1192	1129	1071	0.236
	7	1912	1777	1659	1553	1459	1375	1300	1231	1170	0.212
	8	2038	1901	1779	1670	1571	1483	1404	1331	1266	0.193
	9	2156	2018	1893	1780	1679	1587	1504	1428	1359	0.177
10	2265	2126	2000	1885	1781	1687	1601	1522	1450	0.164	
36/5 Dxx* B = 372 F = 435	0	694	627	572	525	485	450	420	393	369	0.835
	1	876	805	742	682	631	586	547	513	483	0.601
	2	1037	957	888	827	774	722	675	633	596	0.469
	3	1185	1098	1022	955	896	843	796	753	709	0.385
	4	1318	1228	1147	1076	1012	954	902	855	813	0.326
	5	1438	1346	1263	1188	1120	1059	1003	953	907	0.283
	6	1545	1453	1368	1291	1221	1157	1099	1046	997	0.250
	7	1641	1549	1465	1387	1315	1250	1189	1134	1083	0.224
	8	1725	1636	1552	1475	1403	1336	1274	1217	1164	0.203
	9	1800	1714	1632	1555	1483	1416	1354	1295	1241	0.185
10	1866	1783	1704	1628	1557	1490	1428	1369	1314	0.170	
36/4 Dxx* B = 526 F = 597	0	526	475	432	396	365	339	315	294	276	1.044
	1	710	654	602	553	511	474	442	414	389	0.702
	2	863	799	743	694	651	610	570	534	503	0.529
	3	998	930	869	815	767	723	684	649	616	0.424
	4	1114	1045	982	925	873	826	784	745	710	0.354
	5	1214	1146	1082	1024	970	921	876	835	797	0.304
	6	1300	1233	1170	1112	1058	1008	962	919	879	0.266
	7	1372	1309	1248	1191	1137	1087	1040	996	955	0.237
	8	1434	1374	1316	1260	1208	1158	1111	1066	1025	0.213
	9	1487	1430	1375	1322	1271	1222	1175	1131	1090	0.194
10	1532	1479	1427	1376	1327	1279	1234	1191	1149	0.178	

Shaded Area does not conform to SDI maximum fastener spacing of 36" o.c. for spans greater than 5' 0".

* Dxx is a warping factor dependent on the end fastener pattern and used in the equation for G'.

Values to the right of bold line may exceed the maximum recommended spans.

Deck Profile	Nominal Shear Strength due to Panel Buckling (S_{nb}), PLF									$\Omega_b = 2, \phi_b = .8$	
	5.0	5.5	6.0	6.5	7.0	7.5	8.0	8.5	9.0		
F18	4200	3471	2917	2485	2143	1867	1641	1453	1296		
B18	4824	3987	3350	2854	2461	2144	1884	1669	1489		

$$G' = \frac{K_2}{K_4 + 0.3D_{xx}/L_v + 3K_1L_v} \text{ (kips/in)}$$

B & F Deck
 $K_2 = 1398$
 $K_4 = 3.78$

Design Notes:

Choose more severe factored resistance:

LRFD lesser of $\phi_b S_{nb}$ and ϕS_n

ASD lesser of S_{nb}/Ω_b and S_n/Ω

If load = wind, see interaction calculator on web.



ROOF DECK - Screw Screw

F Deck 18 gage Diaphragm Tables $F_y = 40$ ksi

Fastener Support #12 or #14 screw
Side-Lap #10 screw

Strength/Fast.
 $Q_t = 1896$ lb.
 $Q_s = 1019$ lb.

Load	Ω	ϕ
Seismic	2.50	0.65
Wind	2.35	0.70
Other	2.50	0.65

Fastener Pattern	Side-Lap Conn./Span	Nominal Shear Strength (S_n), PLF								K1	
		Span (L_v), Ft.									
		5.0	5.5	6.0	6.5	7.0	7.5	8.0	8.5	9.0	
30/6 Dxx* F = 111	0	672	607	554	508	469	436	406	380	357	0.928
	1	875	792	723	665	615	571	534	500	470	0.682
	2	1070	978	893	822	760	707	661	620	583	0.539
	3	1246	1144	1056	979	906	843	788	740	697	0.445
	4	1413	1301	1204	1119	1046	979	916	860	810	0.380
	5	1572	1451	1345	1254	1173	1102	1038	980	923	0.331
	6	1721	1593	1481	1383	1296	1219	1150	1088	1032	0.293
	7	1860	1727	1610	1507	1415	1332	1258	1192	1132	0.263
	8	1990	1854	1733	1625	1529	1442	1364	1293	1229	0.239
	9	2112	1973	1849	1738	1638	1547	1465	1391	1324	0.218
10	2224	2085	1959	1845	1742	1649	1564	1486	1415	0.201	
30/4 Dxx* F = 760	0	651	589	537	493	455	422	393	368	346	1.044
	1	830	763	706	649	600	558	521	488	459	0.742
	2	987	912	847	790	740	694	648	608	572	0.576
	3	1128	1048	978	915	859	809	765	724	685	0.470
	4	1254	1171	1097	1031	971	917	868	824	784	0.398
	5	1365	1282	1206	1137	1075	1018	966	919	875	0.344
	6	1463	1381	1304	1234	1170	1111	1057	1008	962	0.304
	7	1549	1468	1393	1323	1258	1198	1143	1091	1044	0.272
	8	1624	1546	1473	1404	1339	1278	1222	1170	1121	0.246
	9	1689	1615	1544	1476	1412	1352	1296	1243	1193	0.224
10	1747	1676	1608	1542	1479	1420	1364	1311	1261	0.206	
30/3 Dxx* F = 954	0	479	433	393	360	332	308	286	267	250	1.518
	1	650	601	558	517	478	443	413	387	363	0.954
	2	789	734	686	643	605	570	539	507	477	0.696
	3	905	849	799	753	711	673	639	608	579	0.548
	4	1000	946	895	849	806	766	729	696	665	0.451
	5	1079	1027	978	932	889	848	811	776	743	0.384
	6	1143	1094	1048	1003	961	921	883	848	815	0.334
	7	1195	1151	1107	1064	1024	985	948	913	879	0.296
	8	1239	1198	1157	1117	1078	1041	1005	970	937	0.265
	9	1274	1237	1199	1162	1125	1090	1055	1022	990	0.240
10	1304	1270	1235	1201	1166	1133	1100	1067	1036	0.220	

Shaded Area does not conform to SDI maximum fastener spacing of 36" o.c. for spans greater than 5' 0".

* D_{xx} is a warping factor dependent on the end fastener pattern and used in the equation for G' .

Values to the right of bold line may exceed the maximum recommended spans.

Deck Profile	Nominal Shear Strength due to Panel Buckling (S_{nb}), PLF								$\Omega_b = 2, \phi_b = .8$	
	5.0	5.5	6.0	6.5	7.0	7.5	8.0	8.5	9.0	
F18	4200	3471	2917	2485	2143	1867	1641	1453	1296	

$$G' = \frac{K_2}{K_4 + 0.3D_{xx}/L_v + 3K_1L_v} \text{ (kips/in)}$$

F Deck
 $K_2 = 1398$
 $K_4 = 3.78$

Design Notes:

Choose more severe factored resistance:

LRFD lesser of $\phi_b S_{nb}$ and ϕS_n

ASD lesser of S_{nb}/Ω_b and S_n/Ω

If load = wind, see interaction calculator on web.



ROOF DECK - Screw Screw

B Deck 16 gage Diaphragm Tables $F_y = 40$ ksi

Fastener Support #12 or #14 screw
Side-Lap #10 screw

Strength/Fast.
 $Q_f = 2392$ lb.
 $Q_s = 1286$ lb.

Load	Ω	ϕ
Seismic	2.50	0.65
Wind	2.35	0.70
Other	2.50	0.65

Fastener Pattern	Side-Lap Conn./Span	Nominal Shear Strength (S_n), PLF									K1
		Span (L_v), Ft.									
		6.0	6.5	7.0	7.5	8.0	8.5	9.0	9.5	10.0	
36/7 Dxx* B = 45	0	786	723	668	621	580	543	511	482	456	0.782
	1	1001	921	852	792	740	694	653	617	584	0.590
	2	1215	1118	1036	964	901	846	796	752	713	0.474
	3	1405	1305	1218	1135	1062	997	939	888	841	0.396
	4	1589	1479	1382	1297	1221	1148	1082	1023	970	0.340
	5	1765	1646	1541	1448	1365	1290	1224	1158	1098	0.298
	6	1933	1806	1694	1594	1504	1424	1351	1285	1225	0.265
	7	2093	1960	1841	1735	1640	1554	1476	1405	1340	0.239
	8	2244	2106	1982	1871	1771	1680	1597	1522	1453	0.217
	9	2388	2246	2118	2002	1897	1802	1715	1636	1563	0.199
10	2523	2379	2247	2128	2019	1920	1829	1746	1670	0.184	
36/5 Dxx* B = 262	0	727	668	617	573	535	501	471	444	420	0.938
	1	938	866	801	745	696	652	614	579	548	0.675
	2	1120	1043	976	916	856	804	757	715	677	0.527
	3	1290	1205	1130	1064	1004	950	900	850	805	0.432
	4	1448	1357	1276	1204	1138	1079	1026	977	932	0.366
	5	1593	1498	1413	1336	1266	1202	1144	1091	1043	0.318
	6	1726	1629	1541	1460	1387	1319	1258	1201	1149	0.281
	7	1848	1750	1660	1577	1501	1430	1366	1306	1251	0.251
	8	1958	1860	1770	1685	1608	1535	1469	1407	1349	0.228
	9	2059	1962	1871	1787	1708	1634	1566	1502	1443	0.208
10	2150	2054	1965	1880	1801	1727	1658	1592	1532	0.191	
36/4 Dxx* B = 371	0	550	505	466	432	403	376	353	333	314	1.173
	1	763	703	650	604	563	528	496	468	442	0.788
	2	938	876	821	772	724	679	639	603	571	0.594
	3	1097	1028	967	913	863	818	778	739	700	0.476
	4	1239	1167	1102	1043	989	940	895	854	817	0.397
	5	1365	1292	1224	1162	1106	1054	1006	961	921	0.341
	6	1477	1403	1335	1272	1213	1159	1109	1062	1019	0.299
	7	1574	1502	1434	1371	1312	1256	1204	1156	1111	0.266
	8	1660	1590	1523	1461	1401	1345	1293	1244	1197	0.239
	9	1735	1668	1603	1541	1483	1427	1375	1325	1278	0.218
10	1800	1736	1674	1614	1557	1502	1450	1400	1353	0.200	

Shaded Area does not conform to SDI maximum fastener spacing of 36" o.c. for spans greater than 5' 0".

* Dxx is a warping factor dependent on the end fastener pattern and used in the equation for G' .

Deck Profile	Nominal Shear Strength due to Panel Buckling (S_{nb}), PLF									$\Omega_b = 2, \phi_b = .8$
	6.0	6.5	7.0	7.5	8.0	8.5	9.0	9.5	10.0	
B16	4884	4162	3588	3126	2747	2434	2171	1948	1758	

$$G' = \frac{K_2}{K_4 + 0.3D_{xx}/L_v + 3K_1L_v} \text{ (kips/in)}$$

B Deck
 $K_2 = 1794$
 $K_4 = 3.78$

Design Notes:

Choose more severe factored resistance:

LRFD lesser of $\phi_b S_{nb}$ and ϕS_n

ASD lesser of S_{nb}/Ω_b and S_n/Ω

If load = wind, see interaction calculator on web.



ROOF DECK - Screw Screw

N Deck 22 & 20 gage Diaphragm Tables $F_y = 40$ ksi

Load	Ω	ϕ
Seismic	2.50	0.65
Wind	2.35	0.70
Other	2.50	0.65

Fastener Support #12 or #14 screw
Side-Lap #10 screw

Nominal Shear Strength (S_n), PLF 22 ga. design thickness (t)=0.0295 in.
Strength/Fast. $Q_t = 1180$ lb. $Q_s = 634$ lb.

Fastener Pattern	Side-Lap Conn./Span	Span (L_v), Ft.									K1
		8.0	8.5	9.0	9.5	10.0	10.5	11.0	11.5	12.0	
	0	189	178	168	159	151	144	138	132	126	1.235
	2	348	327	309	293	278	265	253	242	232	0.625
	3	427	402	380	360	342	325	311	297	285	0.502
	4	506	477	450	426	405	386	368	352	338	0.419
24/4	5	581	550	521	493	468	446	426	407	390	0.359
	6	646	613	583	555	530	507	484	463	443	0.315
Dxx*	7	709	673	641	611	584	559	536	515	495	0.280
N = 653	8	768	731	697	666	637	610	585	563	541	0.252
	9	825	786	750	718	687	659	633	609	586	0.229
	10	878	838	802	768	736	707	679	654	630	0.210
	11	929	888	850	815	783	752	724	697	673	0.194

Nominal Shear Strength (S_n), PLF 20 ga. design thickness (t)=0.0358 in.
Strength/Fast. $Q_t = 1432$ lb. $Q_s = 770$ lb.

Fastener Pattern	Side-Lap Conn./Span	Span (L_v), Ft.								K1	
		9.0	9.5	10.0	10.5	11.0	11.5	12.0	12.5		13.0
	0	204	193	184	175	167	160	153	147	141	1.361
	3	461	436	415	395	377	361	345	332	319	0.553
	4	546	517	492	468	447	427	410	393	378	0.461
24/4	5	632	598	569	541	517	494	474	455	437	0.396
	6	707	674	643	615	587	561	538	516	497	0.347
Dxx*	7	778	742	709	679	651	625	601	578	556	0.308
N=488	8	846	808	773	740	710	683	657	633	611	0.278
	9	911	871	834	800	768	739	712	686	662	0.253
	10	973	931	893	857	824	794	765	738	713	0.232
	11	1032	989	950	913	879	846	816	788	762	0.214
	12	1088	1045	1004	966	931	897	866	837	809	0.199

Shaded Area does not conform to SDI maximum fastener spacing of 36" o.c. for spans greater than 5' 0".

* D_{xx} is a warping factor dependent on the end fastener pattern and used in the the equation for G' .

Deck Profile	K_2	Nominal Shear Strength due to Panel Buckling (S_{nb}), PLF $\Omega_b = 2, \phi_b = .8$										
		8.0	8.5	9.0	9.5	10.0	10.5	11.0	11.5	12.0	12.5	13.0
N22	870	2205	1953	1742	1564	1411	1280	1166	1067	980		
N20	1056			2445	2195	1981	1797	1637	1498	1376	1268	1172

$$G' = \frac{K_2}{K_4 + 0.3D_{xx}/L_v + 3K_1L_v} \text{ (kips/in)}$$

N Deck $K_4 = 4.31$

Design Notes:
Choose more severe factored resistance:
LRFD lesser of $\phi_b S_{nb}$ and ϕS_n
ASD lesser of S_{nb}/Ω_b and S_n/Ω
If load = wind, see interaction calculator on web.

DIAPHRAGM



ROOF DECK - Screw Screw

N Deck 18 & 16 gage Diaphragm Tables $F_y = 40$ ksi

Fastener Support #12 or #14 screw
Side-Lap #10 screw

Load	Ω	ϕ
Seismic	2.50	0.65
Wind	2.35	0.70
Other	2.50	0.65

Nominal Shear Strength (S_n), PLF 18 ga. design thickness (t)=0.0474 in.
Strength/Fast. $Q_t = 1896$ lb. $Q_s = 1019$ lb.

Fastener Pattern	Side-Lap Conn./Span	Span (L_v), Ft.								K1	
		10.0	10.5	11.0	11.5	12.0	12.5	13.0	13.5		14.0
	0	243	232	221	211	203	195	187	180	174	1.566
	4	651	620	592	566	542	521	501	482	465	0.531
	5	753	717	684	655	627	602	579	558	538	0.455
24/4	6	852	814	777	743	712	684	657	633	610	0.399
	7	939	899	862	827	796	765	736	709	683	0.355
Dxx [*]	8	1023	980	941	904	870	838	809	781	755	0.320
N = 321	9	1104	1059	1017	978	942	908	877	847	820	0.291
	10	1182	1135	1091	1051	1013	977	944	912	883	0.266
	11	1258	1209	1163	1121	1081	1043	1008	976	945	0.246
	12	1330	1279	1232	1188	1147	1108	1072	1037	1005	0.229
	13	1398	1347	1299	1254	1211	1171	1133	1097	1064	0.213

Nominal Shear Strength (S_n), PLF 16 ga. design thickness (t)=0.0598 in.
Strength/Fast. $Q_t = 2392$ lb. $Q_s = 1286$ lb.

Fastener Pattern	Side-Lap Conn./Span	Span (L_v), Ft.								K1	
		11.0	11.5	12.0	12.5	13.0	13.5	14.0	14.5		15.0
	0	279	267	256	245	236	227	219	212	205	1.759
	3	630	602	577	554	533	513	495	478	462	0.714
	4	746	714	684	657	632	608	586	566	547	0.596
	5	863	826	791	760	731	703	678	655	633	0.512
24/4	6	980	938	899	863	829	799	770	744	719	0.448
	7	1087	1044	1004	965	928	894	862	832	805	0.399
Dxx [*]	8	1187	1140	1097	1057	1020	985	953	921	890	0.359
N=226	9	1283	1234	1189	1146	1106	1069	1034	1001	970	0.326
	10	1377	1325	1277	1232	1190	1151	1114	1079	1046	0.299
	11	1467	1414	1364	1316	1272	1231	1192	1155	1120	0.276
	12	1555	1499	1447	1398	1352	1309	1268	1229	1193	0.257
	13	1639	1581	1528	1477	1429	1385	1342	1302	1264	0.240

Shaded Area does not conform to SDI maximum fastener spacing of 36" o.c. for spans greater than 5' 0".

^{*} D_{xx} is a warping factor dependent on the end fastener pattern and used in equation for G' .

Tables are based on 3 span conditions. Values to the right of double lines exceed practical production limits.

At 2 spans strengths are generally higher and stiffness reduction is less than 19% of the table values.

Deck Profile	K ₂	Nominal Shear Strength due to Panel Buckling (S_{nb}), PLF $\Omega_b = 2, \phi_b = .8$										
		10.0	10.5	11.0	11.5	12.0	12.5	13.0	13.5	14.0	14.5	15.0
N18	1398	3206	2908	2649	2424	2226	2052	1897	1759	1636		
N16	1764			3990	3651	3353	3090	2857	2649	2463	2296	2146

$$G' = \frac{K_2}{K_4 + 0.3D_{xx}/L_v + 3K_1L_v} \text{ (kips/in)}$$

N Deck
 $K_4 = 4.31$

Design Notes:

Choose more severe factored resistance:

LRFD lesser of $\phi_b S_{nb}$ and ϕS_n

ASD lesser of S_{nb}/Ω_b and S_n/Ω

If load = wind, see interaction calculator on web.



COMPOSITE DECK, Lok-Floor and B-Lok - Normal Weight, Weld Weld

Deck: $F_y = 40$ ksi Fastener Pattern = 36/4, 24/3*
 Concrete: 145 pcf $f'c = 3$ ksi with 2 1/2" cover over deck
 Fastener Support 5/8" ϕ puddle welds (Q_t)
 Side-Lap 5/8" ϕ puddle welds or 1 1/2" fillet weld (Q_s)

Load Type	ASD	LRFD
	Ω	ϕ
All	3.25	0.50
	S_n/Ω	ϕS_n

B-Lok, 1.5, 2, 3 Lok-Floor Composite Deck Slab Diaphragm Tables

Deck "t"	Side-Lap Conn. / Span	Nominal Shear Strength (S_n), PLF										K_1		
		Span (L_n), Ft.												
		5.0	5.5	6.0	6.5	7.0	7.5	8.0	8.5	9.0	9.5	10.0		
22 gage	0.0295	0	5500	5446	5401	5363	5330	5302	5277	5255	5235	5218	5202	0.729
	Strength / Fastener	1	5802	5720	5652	5595	5545	5503	5465	5432	5403	5377	5353	0.358
		2	6103	5994	5903	5826	5761	5703	5654	5609	5570	5535	5504	0.237
	Q_t	3	6405	6268	6155	6058	5976	5904	5842	5787	5738	5694	5654	0.177
		4	6706	6542	6406	6290	6191	6105	6030	5964	5905	5853	5805	0.142
	2010 lb	5	7007	6816	6657	6522	6407	6306	6219	6141	6073	6011	5956	0.118
		6	7309	7090	6908	6754	6622	6507	6407	6319	6240	6170	6107	0.101
	Q_s	7	7610	7364	7159	6986	6837	6708	6596	6496	6408	6329	6257	0.088
		8	7912	7638	7411	7218	7053	6909	6784	6673	6575	6487	6408	0.078
1507 lb	9	8213	7913	7662	7450	7268	7110	6972	6851	6743	6646	6559	0.071	
20 gage	0.0358	0	5620	5555	5501	5455	5415	5381	5351	5325	5302	5281	5262	0.803
	Strength / Fastener	1	5982	5884	5802	5733	5674	5623	5578	5538	5503	5471	5443	0.394
		2	6344	6213	6104	6012	5932	5864	5804	5751	5704	5662	5624	0.261
	Q_t	3	6706	6542	6405	6290	6191	6105	6030	5964	5905	5852	5805	0.195
		4	7068	6871	6707	6568	6450	6347	6256	6177	6106	6043	5986	0.156
	2413 lb	5	7430	7200	7009	6847	6708	6588	6483	6390	6307	6233	6167	0.130
		6	7792	7529	7310	7125	6967	6829	6709	6603	6508	6424	6348	0.111
	Q_s	7	8154	7858	7612	7404	7225	7070	6935	6816	6709	6614	6529	0.097
		8	8516	8187	7914	7682	7484	7312	7161	7029	6911	6805	6710	0.086
1810 lb	9	8877	8516	8215	7961	7742	7553	7388	7241	7112	6995	6891	0.078	
18 gage	0.0474	0	5833	5749	5678	5619	5568	5523	5485	5451	5420	5393	5369	0.923
	Strength / Fastener	1	6303	6176	6070	5980	5903	5837	5778	5727	5681	5640	5604	0.454
		2	6773	6603	6461	6341	6239	6150	6072	6003	5942	5888	5838	0.301
	Q_t	3	7242	7030	6853	6703	6574	6463	6366	6280	6203	6135	6073	0.225
		4	7712	7457	7244	7064	6910	6776	6659	6556	6464	6382	6308	0.180
	3132 lb	5	8182	7884	7636	7426	7246	7089	6953	6832	6725	6629	6543	0.150
		6	8652	8311	8027	7787	7581	7403	7247	7109	6986	6877	6778	0.128
	Q_s	7	9122	8738	8419	8148	7917	7716	7540	7385	7247	7124	7013	0.112
		8	9592	9165	8810	8510	8252	8029	7834	7661	7508	7371	7248	0.099
2349 lb	9	10061	9593	9202	8871	8588	8342	8127	7938	7769	7618	7483	0.090	
16 gage	0.0598	0	6051	5947	5860	5786	5723	5669	5621	5579	5541	5508	5478	1.037
	Strength / Fastener	1	6631	6474	6343	6232	6138	6055	5983	5920	5863	5813	5768	0.510
		2	7211	7001	6826	6679	6552	6442	6346	6261	6186	6118	6058	0.338
	Q_t	3	7791	7528	7310	7125	6966	6829	6708	6602	6508	6423	6348	0.253
		4	8371	8056	7793	7571	7380	7215	7071	6943	6830	6729	6638	0.202
	3867 lb	5	8951	8583	8276	8017	7795	7602	7433	7285	7152	7034	6928	0.168
		6	9531	9110	8760	8463	8209	7989	7796	7626	7475	7339	7218	0.144
	Q_s	7	10111	9637	9243	8909	8623	8375	8158	7967	7797	7645	7508	0.126
		8	10691	10165	9726	9355	9037	8762	8521	8308	8119	7950	7798	0.112
2900 lb	9	11271	10692	10210	9802	9452	9149	8883	8649	8441	8255	8087	0.101	

- NOTES
1. Shaded Area does not conform to SDI maximum fastener spacing of 36" o.c. for spans greater than 5' 0".
 2. See Slab Tables for the maximum unshored spans and slab load capacities.
 3. Canam does not recommend the use of weld washers on deck thicker than or equal to 22 gage or welded side laps at 22 gage.
- * Table values are based on a 36/4 pattern. Capacities for the 24/3 pattern are within 2.5% of the table values.

$$G' = \frac{K_2}{K_4 + 3K_1L_v} + K_3 \text{ (kips/in)}$$

t	.0295	.0358	.0474	.0598
K_2	870	1056	1398	1764
K_3	2380			

Deck	K_4
B-Lok	3.78
1.5 Lok-Floor	2.89
2 Lok-Floor	3.14
3 Lok-Floor	3.54

TABLES



COMPOSITE DECK, Lok-Floor and B-Lok - Light Weight, Weld Weld

Deck: $F_y = 40$ ksi Fastener Pattern = 36/4, 24/3*
 Concrete: 115 pcf $f'c = 3$ ksi with 2 1/2" cover over deck
 Fastener Support 5/8" ϕ puddle welds (Q_t)
 Side-Lap 5/8" ϕ puddle welds or 1 1/2" fillet weld (Q_s)

Load Type	ASD	LRFD
	Ω	ϕ
All	3.25	0.50
	S_p/Ω	ϕS_n

B-Lok, 1.5, 2, 3 Lok-Floor Composite Deck Slab Diaphragm Tables

Deck "t"	Side-Lap Conn. / Span	Nominal Shear Strength (S_n), PLF										K_1		
		Span (L_v), Ft.												
		5.0	5.5	6.0	6.5	7.0	7.5	8.0	8.5	9.0	9.5	10.0		
22 gage	0.0295	0	4060	4006	3961	3922	3890	3861	3836	3815	3795	3778	3762	0.729
	Strength / Fastener	1	4361	4280	4212	4154	4105	4062	4025	3992	3963	3936	3913	0.358
		2	4663	4554	4463	4386	4320	4263	4213	4169	4130	4095	4063	0.237
	Q_t	3	4964	4828	4714	4618	4536	4464	4402	4346	4297	4254	4214	0.177
		4	5266	5102	4965	4850	4751	4665	4590	4524	4465	4412	4365	0.142
	2010 lb	5	5567	5376	5217	5082	4966	4866	4778	4701	4632	4571	4516	0.118
		6	5869	5650	5468	5314	5182	5067	4967	4878	4800	4730	4666	0.101
	Q_s	7	6170	5924	5719	5546	5397	5268	5155	5056	4967	4888	4817	0.088
		8	6472	6198	5970	5777	5612	5469	5344	5233	5135	5047	4968	0.078
1507 lb	9	6773	6472	6221	6009	5828	5670	5532	5410	5302	5206	5118	0.071	
20 gage	0.0358	0	4180	4114	4060	4014	3975	3941	3911	3885	3861	3841	3822	0.803
	Strength / Fastener	1	4541	4444	4362	4293	4234	4182	4137	4098	4063	4031	4003	0.394
		2	4903	4773	4664	4571	4492	4424	4364	4311	4264	4222	4184	0.261
	Q_t	3	5265	5102	4965	4850	4751	4665	4590	4524	4465	4412	4365	0.195
		4	5627	5431	5267	5128	5009	4906	4816	4737	4666	4603	4546	0.156
	2413 lb	5	5989	5760	5568	5407	5268	5148	5042	4949	4867	4793	4727	0.130
		6	6351	6089	5870	5685	5526	5389	5269	5162	5068	4984	4908	0.111
	Q_s	7	6713	6418	6172	5963	5785	5630	5495	5375	5269	5174	5089	0.097
		8	7075	6747	6473	6242	6043	5871	5721	5588	5470	5365	5270	0.086
1810 lb	9	7437	7076	6775	6520	6302	6113	5947	5801	5671	5555	5451	0.078	
18 gage	0.0474	0	4393	4308	4238	4178	4127	4083	4044	4010	3980	3953	3928	0.923
	Strength / Fastener	1	4863	4735	4629	4540	4463	4396	4338	4287	4241	4200	4163	0.454
		2	5332	5162	5021	4901	4799	4710	4632	4563	4502	4447	4398	0.301
	Q_t	3	5802	5590	5412	5263	5134	5023	4925	4839	4763	4695	4633	0.225
		4	6272	6017	5804	5624	5470	5336	5219	5116	5024	4942	4868	0.180
	3132 lb	5	6742	6444	6195	5985	5805	5649	5513	5392	5285	5189	5103	0.150
		6	7212	6871	6587	6347	6141	5962	5806	5668	5546	5436	5338	0.128
	Q_s	7	7681	7298	6978	6708	6476	6276	6100	5945	5807	5684	5573	0.112
		8	8151	7725	7370	7070	6812	6589	6393	6221	6068	5931	5808	0.099
2349 lb	9	8621	8152	7762	7431	7148	6902	6687	6498	6329	6178	6042	0.090	
16 gage	0.0598	0	4611	4506	4419	4346	4283	4228	4181	4138	4101	4067	4037	1.037
	Strength / Fastener	1	5191	5034	4903	4792	4697	4615	4543	4480	4423	4373	4327	0.510
		2	5771	5561	5386	5238	5111	5002	4906	4821	4745	4678	4617	0.338
	Q_t	3	6351	6088	5869	5684	5526	5388	5268	5162	5068	4983	4907	0.253
		4	6930	6615	6353	6131	5940	5775	5631	5503	5390	5288	5197	0.202
	3867 lb	5	7510	7143	6836	6577	6354	6162	5993	5844	5712	5594	5487	0.168
		6	8090	7670	7319	7023	6769	6548	6356	6185	6034	5899	5777	0.144
	Q_s	7	8670	8197	7803	7469	7183	6935	6718	6527	6356	6204	6067	0.126
		8	9250	8724	8286	7915	7597	7322	7081	6868	6679	6509	6357	0.112
2900 lb	9	9830	9252	8769	8361	8011	7708	7443	7209	7001	6815	6647	0.101	

- NOTES**
1. Shaded Area does not conform to SDI maximum fastener spacing of 36" o.c. for spans greater than 5' 0".
 2. See Slab Tables for the maximum unshored spans and slab load capacities.
 3. Canam does not recommend the use of weld washers on deck thicker than or equal to 22 gage or welded side laps at 22 gage.

* Table values are based on a 36/4 pattern. Capacities for the 24/3 pattern are within 2.5% of the table values.

$$G' = \frac{K_2}{K_4 + 3K_1 L_v} + K_3 \text{ (kips/in)}$$

t	.0295	.0358	.0474	.0598
K_2	870	1056	1398	1764
K_3	2380			

Deck	K_4
B-Lok	3.78
1.5 Lok-Floor	2.89
2 Lok-Floor	3.14
3 Lok-Floor	3.54

DIAPHRAGM

TABLES



COMPOSITE DECK, Lok-Floor and B-Lok - Normal Weight, Weld Screw

Deck: $F_y = 40$ ksi Fastener Pattern = 36/4, 24/3"
 Concrete: 145 pcf $f'c = 3$ ksi with 2 1/2" cover over deck
 Support: 5/8" ϕ puddle welds (Q_t)
 Fastener Side-Lap: # 10 Screws (Q_s)

Load Type	ASD Ω	LRFD ϕ
All	3.25	0.50
	S_u/Ω	ϕS_n

B-Lok, 1.5, 2, 3 Lok-Floor Composite Deck Slab Diaphragm Tables

Deck "t"	Side-Lap Conn. / Span	Nominal Shear Strength (S_n), PLF										K_1		
		Span (L_v), Ft.												
		5.0	5.5	6.0	6.5	7.0	7.5	8.0	8.5	9.0	9.5	10.0		
22 gage	0.0295	0	5500	5446	5401	5363	5330	5302	5277	5255	5235	5218	5202	0.729
		1	5627	5561	5507	5460	5421	5386	5356	5329	5306	5285	5266	0.509
	Strength /	2	5754	5677	5612	5558	5511	5471	5435	5404	5376	5351	5329	0.391
	Fastener	3	5881	5792	5718	5655	5602	5555	5515	5479	5447	5418	5393	0.318
	Q_t	4	6008	5907	5824	5753	5692	5640	5594	5553	5517	5485	5456	0.267
	2010 lb	5	6135	6023	5929	5851	5783	5724	5673	5628	5588	5552	5519	0.231
		6	6261	6138	6035	5948	5874	5809	5752	5703	5658	5619	5583	0.203
	Q_s	7	6388	6253	6141	6046	5964	5894	5832	5777	5729	5685	5646	0.181
	634 lb	8	6515	6369	6247	6143	6055	5978	5911	5852	5799	5752	5710	0.164
	9	6642	6484	6352	6241	6145	6063	5990	5926	5870	5819	5773	0.149	
20 gage	0.0358	0	5620	5555	5501	5455	5415	5381	5352	5325	5302	5281	5262	0.803
		1	5774	5695	5629	5573	5525	5484	5448	5416	5387	5362	5339	0.561
	Strength /	2	5928	5835	5757	5692	5635	5587	5544	5506	5473	5443	5416	0.431
	Fastener	3	6082	5975	5885	5810	5745	5689	5640	5597	5558	5524	5493	0.350
	Q_t	4	6236	6115	6014	5928	5855	5792	5736	5687	5644	5605	5570	0.294
	2413 lb	5	6390	6255	6142	6047	5965	5894	5833	5778	5729	5686	5647	0.254
		6	6544	6394	6270	6165	6075	5997	5929	5869	5815	5767	5724	0.224
	Q_s	7	6697	6534	6399	6284	6185	6100	6025	5959	5900	5848	5801	0.200
	770 lb	8	6851	6674	6527	6402	6295	6202	6121	6050	5986	5929	5878	0.180
	9	7005	6814	6655	6520	6405	6305	6217	6140	6072	6010	5955	0.164	
18 gage	0.0474	0	5833	5749	5678	5619	5568	5523	5485	5451	5420	5393	5369	0.923
		1	6037	5934	5848	5776	5713	5659	5612	5571	5534	5500	5471	0.645
	Strength /	2	6241	6119	6018	5932	5859	5795	5740	5690	5647	5608	5573	0.496
	Fastener	3	6445	6305	6188	6089	6004	5931	5867	5810	5760	5715	5674	0.403
	Q_t	4	6648	6490	6358	6246	6150	6067	5994	5930	5873	5822	5776	0.339
	3132 lb	5	6852	6675	6528	6403	6296	6203	6122	6050	5986	5930	5878	0.293
		6	7056	6860	6697	6559	6441	6339	6249	6170	6100	6037	5980	0.257
	Q_s	7	7260	7046	6867	6716	6587	6475	6377	6290	6213	6144	6082	0.230
	1019 lb	8	7464	7231	7037	6873	6732	6611	6504	6410	6326	6251	6184	0.207
	9	7667	7416	7207	7030	6878	6746	6631	6530	6439	6359	6286	0.189	
16 gage	0.0598	0	6051	5947	5860	5786	5723	5669	5621	5579	5541	5508	5478	1.037
		1	6308	6180	6074	5984	5907	5840	5782	5730	5684	5643	5606	0.725
	Strength /	2	6565	6414	6288	6182	6091	6012	5942	5881	5827	5778	5735	0.557
	Fastener	3	6822	6648	6503	6380	6274	6183	6103	6033	5970	5914	5863	0.452
	Q_t	4	7079	6882	6717	6577	6458	6354	6264	6184	6113	6049	5992	0.381
	3867 lb	5	7337	7115	6931	6775	6642	6526	6424	6335	6256	6184	6120	0.329
		6	7594	7349	7145	6973	6825	6697	6585	6486	6398	6320	6249	0.289
	Q_s	7	7851	7583	7360	7171	7009	6869	6746	6638	6541	6455	6378	0.258
	1286 lb	8	8108	7817	7574	7369	7193	7040	6907	6789	6684	6590	6506	0.233
	9	8365	8051	7788	7566	7376	7212	7067	6940	6827	6726	6635	0.212	

- NOTES
1. Shaded Area does not conform to SDI maximum fastener spacing of 36" o.c. for spans greater than 5' 0".
 2. See Slab Tables for the maximum unshored spans and slab load capacities.
 3. Canam does not recommend the use of weld washers on deck thicker than or equal to 22 gage.
- * Table values are based on a 36/4 pattern. Capacities for the 24/3 pattern are within 2.5% of the table values.

$$G' = \frac{K_2}{K_t + 3K_1 L_v} + K_3 \text{ (kips/in)}$$

t	.0295	.0358	.0474	.0598
K_2	870	1056	1398	1764
K_3	2380			

Deck	K_4
B-Lok	3.78
1.5 Lok-Floor	2.89
2 Lok-Floor	3.14
3 Lok-Floor	3.54

TABLES



COMPOSITE DECK, Lok-Floor and B-Lok - Light Weight, Weld Screw

Deck: $F_y = 40$ ksi Fastener Pattern = 36/4, 24/3*
 Concrete: 115 pcf $f'c = 3$ ksi with 2 1/2" cover over deck
 Fastener Support 5/8" ϕ puddle welds (Q_f)
 Side-Lap # 10 Screws (Q_s)

Load Type	ASD Ω	LRFD ϕ
All	3.25	0.50
	S_{PL}/Ω	ϕS_n

B-Lok, 1.5, 2, 3 Lok-Floor Composite Deck Slab Diaphragm Tables

Deck "t"	Side-Lap Conn. / Span	Nominal Shear Strength (S_n), PLF										K_1		
		Span (L_v), Ft.												
22 gage	0.0295	0	4060	4006	3961	3922	3890	3861	3836	3815	3795	3778	3762	0.729
		1	4187	4121	4066	4020	3980	3946	3916	3889	3866	3844	3825	0.509
	Strength / Fastener	2	4314	4236	4172	4118	4071	4030	3995	3964	3936	3911	3889	0.391
	Q_f	3	4440	4352	4278	4215	4161	4115	4074	4038	4006	3978	3952	0.318
	2010 lb	4	4567	4467	4383	4313	4252	4200	4154	4113	4077	4045	4016	0.267
		5	4694	4582	4489	4410	4343	4284	4233	4188	4147	4111	4079	0.231
	Q_s	6	4821	4698	4595	4508	4433	4369	4312	4262	4218	4178	4142	0.203
		7	4948	4813	4701	4605	4524	4453	4391	4337	4288	4245	4206	0.181
	634 lb	8	5075	4928	4806	4703	4614	4538	4471	4411	4359	4312	4269	0.164
9		5202	5044	4912	4801	4705	4622	4550	4486	4429	4378	4333	0.149	
20 gage	0.0358	0	4180	4114	4060	4014	3975	3941	3911	3885	3861	3841	3822	0.803
		1	4333	4254	4189	4133	4085	4044	4007	3975	3947	3922	3899	0.561
	Strength / Fastener	2	4487	4394	4317	4251	4195	4146	4104	4066	4033	4003	3976	0.431
	Q_f	3	4641	4534	4445	4370	4305	4249	4200	4157	4118	4084	4053	0.350
	2413 lb	4	4795	4674	4573	4488	4415	4352	4296	4247	4204	4165	4130	0.294
		5	4949	4814	4702	4606	4525	4454	4392	4338	4289	4246	4207	0.254
	Q_s	6	5103	4954	4830	4725	4635	4557	4488	4428	4375	4327	4284	0.224
		7	5257	5094	4958	4843	4745	4659	4585	4519	4460	4408	4361	0.200
	770 lb	8	5411	5234	5087	4962	4855	4762	4681	4609	4546	4489	4437	0.180
9		5565	5374	5215	5080	4965	4865	4777	4700	4631	4570	4514	0.164	
18 gage	0.0474	0	4393	4308	4238	4178	4127	4083	4044	4010	3980	3953	3928	0.923
		1	4597	4494	4408	4335	4273	4219	4172	4130	4093	4060	4030	0.645
	Strength / Fastener	2	4800	4679	4578	4492	4419	4355	4299	4250	4206	4167	4132	0.496
	Q_f	3	5004	4864	4747	4649	4564	4491	4427	4370	4320	4275	4234	0.403
	3132 lb	4	5208	5049	4917	4806	4710	4627	4554	4490	4433	4382	4336	0.339
		5	5412	5235	5087	4962	4855	4763	4681	4610	4546	4489	4438	0.293
	Q_s	6	5616	5420	5257	5119	5001	4898	4809	4730	4659	4596	4540	0.257
		7	5819	5605	5427	5276	5146	5034	4936	4850	4773	4704	4642	0.230
	1019 lb	8	6023	5791	5597	5433	5292	5170	5064	4969	4886	4811	4744	0.207
9		6227	5976	5767	5589	5438	5306	5191	5089	4999	4918	4846	0.189	
16 gage	0.0598	0	4611	4506	4419	4346	4283	4228	4181	4138	4101	4067	4037	1.037
		1	4868	4740	4634	4544	4467	4400	4341	4290	4244	4203	4166	0.725
	Strength / Fastener	2	5125	4974	4848	4742	4650	4571	4502	4441	4387	4338	4294	0.557
	Q_f	3	5382	5208	5062	4939	4834	4743	4663	4592	4530	4473	4423	0.452
	3867 lb	4	5639	5441	5277	5137	5018	4914	4823	4743	4672	4609	4552	0.381
		5	5896	5675	5491	5335	5201	5085	4984	4895	4815	4744	4680	0.329
	Q_s	6	6153	5909	5705	5533	5385	5257	5145	5046	4958	4879	4809	0.289
		7	6411	6143	5919	5731	5569	5428	5306	5197	5101	5015	4937	0.258
	1286 lb	8	6668	6376	6134	5928	5752	5600	5466	5348	5244	5150	5066	0.233
9		6925	6610	6348	6126	5936	5771	5627	5500	5387	5285	5194	0.212	

- NOTES**
1. Shaded Area does not conform to SDI maximum fastener spacing of 36" o.c. for spans greater than 5' 0".
 2. See Slab Tables for the maximum unshored spans and slab load capacities.
 3. Canam does not recommend the use of weld washers on deck thicker than or equal to 22 gage.
- * Table values are based on a 36/4 pattern. Capacities for the 24/3 pattern are within 2.5% of the table values.

$$G' = \frac{K_2}{K_4 + 3K_1 L_v} + K_3 \text{ (kips/in)}$$

t	.0295	.0358	.0474	.0598
K_2	870	1056	1398	1764
K_3	2380			

Deck	K_4
B-Lok	3.78
1.5 Lok-Floor	2.89
2 Lok-Floor	3.14
3 Lok-Floor	3.54

DIAPHRAGM

TABLES



COMPOSITE DECK, B-Lok - Normal Weight, Weld Weld

Deck: $F_y = 40$ ksi Fastener Pattern = 36/7
 Concrete: 145 pcf $f'c = 3$ ksi with 2 1/2" cover over deck
 Fastener Support: 5/8" ϕ puddle welds (Q_f)
 Side-Lap: 5/8" ϕ puddle welds or 1 1/2" fillet weld (Q_s)

Load Type	ASD Ω	LRFD ϕ
All	3.25	0.50
	S_u/Ω	ϕS_n

B-Lok-Floor Composite Deck Slab Diaphragm Table

Deck "t"	Side-Lap Conn. / Span	Nominal Shear Strength (S_n), PLF											K_1	
		Span (L_v), Ft.												
		5.0	5.5	6.0	6.5	7.0	7.5	8.0	8.5	9.0	9.5	10.0		
22 gage	0.0295	0	5738	5662	5599	5546	5500	5460	5425	5395	5368	5343	5321	0.486
		1	6040	5936	5850	5778	5715	5661	5614	5572	5535	5502	5472	0.287
	Strength / Fastener	2	6341	6210	6102	6010	5931	5862	5802	5749	5703	5661	5623	0.204
	Q_f	3	6643	6485	6353	6241	6146	6063	5991	5927	5870	5819	5773	0.158
	2010 lb	4	6944	6759	6604	6473	6361	6264	6179	6104	6037	5978	5924	0.129
		5	7245	7033	6855	6705	6577	6465	6368	6281	6205	6137	6075	0.109
		6	7547	7307	7106	6937	6792	6666	6556	6459	6372	6295	6226	0.094
	Q_s	7	7848	7581	7358	7169	7007	6867	6744	6636	6540	6454	6376	0.083
	1507 lb	8	8150	7855	7609	7401	7223	7068	6933	6813	6707	6612	6527	0.074
	9	8451	8129	7860	7633	7438	7269	7121	6991	6875	6771	6678	0.067	
20 gage	0.0358	0	5906	5815	5739	5675	5620	5572	5530	5493	5461	5431	5405	0.535
		1	6268	6144	6040	5953	5878	5813	5756	5706	5662	5622	5586	0.317
	Strength / Fastener	2	6630	6473	6342	6231	6137	6054	5983	5919	5863	5812	5767	0.225
	Q_f	3	6991	6802	6644	6510	6395	6296	6209	6132	6064	6003	5948	0.174
	2413 lb	4	7353	7131	6945	6788	6654	6537	6435	6345	6265	6193	6129	0.142
		5	7715	7460	7247	7067	6912	6778	6661	6558	6466	6384	6310	0.120
		6	8077	7789	7549	7345	7171	7020	6887	6771	6667	6574	6491	0.104
	Q_s	7	8439	8118	7850	7624	7429	7261	7114	6984	6868	6765	6672	0.092
	1810 lb	8	8801	8447	8152	7902	7688	7502	7340	7197	7069	6955	6853	0.082
	9	9163	8776	8453	8180	7946	7744	7566	7410	7270	7146	7034	0.074	
18 gage	0.0474	0	6204	6086	5987	5904	5833	5771	5717	5669	5626	5588	5554	0.615
		1	6674	6513	6379	6265	6168	6084	6010	5945	5887	5836	5789	0.364
	Strength / Fastener	2	7144	6940	6770	6627	6504	6397	6304	6222	6148	6083	6024	0.259
	Q_f	3	7613	7367	7162	6988	6839	6710	6597	6498	6409	6330	6259	0.200
	3132 lb	4	8083	7794	7553	7350	7175	7024	6891	6774	6670	6577	6494	0.164
		5	8553	8221	7945	7711	7510	7337	7185	7051	6931	6825	6729	0.138
		6	9023	8648	8336	8072	7846	7650	7478	7327	7192	7072	6964	0.120
	Q_s	7	9493	9075	8728	8434	8182	7963	7772	7603	7453	7319	7198	0.106
	2349 lb	8	9962	9503	9119	8795	8517	8276	8066	7880	7714	7566	7433	0.094
	9	10432	9930	9511	9157	8853	8590	8359	8156	7975	7814	7668	0.085	
16 gage	0.0598	0	6509	6363	6241	6138	6050	5974	5907	5848	5796	5749	5707	0.691
		1	7089	6890	6725	6585	6465	6361	6270	6189	6118	6054	5996	0.409
	Strength / Fastener	2	7669	7417	7208	7031	6879	6747	6632	6530	6440	6359	6286	0.290
	Q_f	3	8249	7945	7691	7477	7293	7134	6995	6872	6762	6664	6576	0.225
	3867 lb	4	8829	8472	8175	7923	7707	7521	7357	7213	7085	6970	6866	0.184
		5	9409	8999	8658	8369	8122	7907	7720	7554	7407	7275	7156	0.155
		6	9989	9526	9141	8815	8536	8294	8082	7895	7729	7580	7446	0.135
	Q_s	7	10569	10054	9625	9261	8950	8681	8445	8236	8051	7886	7736	0.119
	2900 lb	8	11149	10581	10108	9708	9365	9067	8807	8577	8373	8191	8026	0.106
	9	11729	11108	10591	10154	9779	9454	9169	8919	8696	8496	8316	0.096	

- NOTES
1. Shaded Area does not conform to SDI maximum fastener spacing of 36" o.c. for spans greater than 5' 0".
 2. See Slab Tables for the maximum unshored spans and slab load capacities.
 3. Canam does not recommend the use of weld washers on deck thicker than or equal to 22 gage or welded side laps at 22 gage.

$$G' = \frac{K_2}{K_4 + 3K_1L_v} + K_3 \text{ (kips/in)}$$

t	.0295	.0358	.0474	.0598
K_2	870	1056	1398	1764
K_3	2380			

Deck	K_4
B-Lok	3.78



COMPOSITE DECK, B-Lok - Light Weight, Weld Weld

Deck: $F_y = 40$ ksi Fastener Pattern = 36/7
 Concrete: 115 pcf $f'c = 3$ ksi with 2 1/2" cover over deck
 Fastener Support 5/8" ϕ puddle welds (Q_1)
 Side-Lap 5/8" ϕ puddle welds or 1 1/2" fillet weld (Q_2)

Load Type	ASD Ω	LRFD ϕ
All	3.25	0.50
	S_x/Ω	ϕS_n

B-Lok-Floor Composite Deck Slab Diaphragm Tables

Deck "t"	Side-Lap Conn. / Span	Nominal Shear Strength (S_n), PLF										K_1		
		Span (L_v), Ft.												
		5.0	5.5	6.0	6.5	7.0	7.5	8.0	8.5	9.0	9.5	10.0		
22 gage	0.0295	0	4298	4222	4159	4105	4060	4020	3985	3954	3927	3903	3881	0.486
		1	4599	4496	4410	4337	4275	4221	4174	4132	4095	4062	4032	0.287
		2	4901	4770	4661	4569	4490	4422	4362	4309	4262	4220	4182	0.204
	Strength / Fastener	3	5202	5044	4913	4801	4706	4623	4550	4486	4430	4379	4333	0.158
		4	5504	5318	5164	5033	4921	4824	4739	4664	4597	4537	4484	0.129
		5	5805	5592	5415	5265	5136	5025	4927	4841	4765	4696	4635	0.109
	2010 lb	6	6107	5866	5666	5497	5352	5226	5116	5018	4932	4855	4785	0.094
		7	6408	6140	5917	5729	5567	5427	5304	5196	5100	5013	4936	0.083
		8	6709	6414	6169	5961	5782	5628	5492	5373	5267	5172	5087	0.074
Q_2	9	7011	6688	6420	6192	5998	5829	5681	5550	5435	5331	5237	0.067	
	0.0358	0	4465	4374	4298	4234	4179	4131	4090	4053	4020	3991	3965	0.535
		1	4827	4703	4600	4513	4438	4373	4316	4266	4221	4181	4146	0.317
2		5189	5032	4902	4791	4696	4614	4542	4479	4422	4372	4327	0.225	
Strength / Fastener	3	5551	5361	5203	5069	4955	4855	4768	4692	4623	4562	4508	0.174	
	4	5913	5690	5505	5348	5213	5097	4995	4905	4825	4753	4689	0.142	
	5	6275	6019	5807	5626	5472	5338	5221	5118	5026	4943	4869	0.120	
2413 lb	6	6637	6349	6108	5905	5730	5579	5447	5330	5227	5134	5050	0.104	
	7	6999	6678	6410	6183	5989	5821	5673	5543	5428	5324	5231	0.092	
	8	7361	7007	6711	6462	6248	6062	5900	5756	5629	5515	5412	0.082	
Q_2	9	7723	7336	7013	6740	6506	6303	6126	5969	5830	5705	5593	0.074	
	0.0474	0	4764	4645	4547	4464	4392	4330	4276	4228	4186	4148	4114	0.615
		1	5233	5073	4938	4825	4728	4644	4570	4505	4447	4395	4349	0.364
2		5703	5500	5330	5186	5063	4957	4863	4781	4708	4642	4584	0.259	
Strength / Fastener	3	6173	5927	5721	5548	5399	5270	5157	5058	4969	4890	4818	0.200	
	4	6643	6354	6113	5909	5735	5583	5451	5334	5230	5137	5053	0.164	
	5	7113	6781	6505	6271	6070	5896	5744	5610	5491	5384	5288	0.138	
3132 lb	6	7582	7208	6896	6632	6406	6210	6038	5887	5752	5632	5523	0.120	
	7	8052	7635	7288	6993	6741	6523	6332	6163	6013	5879	5758	0.106	
	8	8522	8062	7679	7355	7077	6836	6625	6439	6274	6126	5993	0.094	
Q_2	9	8992	8489	8071	7716	7412	7149	6919	6716	6535	6373	6228	0.085	
	0.0598	0	5068	4922	4801	4698	4610	4534	4467	4408	4355	4308	4266	0.691
		1	5648	5450	5284	5144	5024	4920	4829	4749	4677	4614	4556	0.409
2		6228	5977	5768	5590	5439	5307	5192	5090	5000	4919	4846	0.290	
Strength / Fastener	3	6808	6504	6251	6037	5853	5694	5554	5431	5322	5224	5136	0.225	
	4	7388	7032	6734	6483	6267	6080	5917	5772	5644	5529	5426	0.184	
	5	7968	7559	7218	6929	6681	6467	6279	6114	5966	5835	5716	0.155	
3867 lb	6	8548	8086	7701	7375	7096	6854	6642	6455	6289	6140	6006	0.135	
	7	9128	8613	8184	7821	7510	7240	7004	6796	6611	6445	6296	0.119	
	8	9708	9141	8668	8267	7924	7627	7367	7137	6933	6750	6586	0.106	
Q_2	9	10288	9668	9151	8713	8338	8013	7729	7478	7255	7056	6876	0.096	

- NOTES**
1. Shaded Area does not conform to SDI maximum fastener spacing of 36" o.c. for spans greater than 5' 0".
 2. See Slab Tables for the maximum unshored spans and slab load capacities.
 3. Canam does not recommend the use of weld washers on deck thicker than or equal to 22 gage or welded side laps at 22 gage.

$$G^* = \frac{K_2}{K_4 + 3K_1L_v} + K_3 \text{ (kips/in)}$$

t	.0295	.0358	.0474	.0598
K_2	870	1056	1398	1764
K_3	2380			

Deck	K_4
B-Lok	3.78

DIAPHRAGM

TABLES



COMPOSITE DECK, B-Lok - Normal Weight, Weld Screw

Deck: $F_y = 40$ ksi Fastener Pattern = 36/7
 Concrete: 145 pcf $f'_c = 3$ ksi with 2 1/2" cover over deck
 Fastener Support 5/8" ϕ puddle welds (Q_f)
 Side-Lap # 10 screws (Q_s)

Load Type	ASD Ω	LRFD ϕ
All	3.25 S_u/Ω	0.50 ϕS_n

B-Lok-Floor Composite Deck Slab Diaphragm Tables

Deck "t"	Side-Lap Conn. / Span	Nominal Shear Strength (S_n), PLF										K_1		
		Span (L_v), Ft.												
		5.0	5.5	6.0	6.5	7.0	7.5	8.0	8.5	9.0	9.5	10.0		
22 gage	0	5738	5662	5599	5546	5500	5460	5425	5395	5368	5343	5321	0.486	
	0.0295	1	5865	5778	5705	5643	5591	5545	5505	5469	5438	5410	5385	0.377
	Strength / Fastener	2	5992	5893	5811	5741	5681	5629	5584	5544	5509	5477	5448	0.308
	Q_f	3	6119	6008	5916	5838	5772	5714	5663	5619	5579	5543	5512	0.261
	2010 lb	4	6246	6124	6022	5936	5862	5799	5743	5693	5649	5610	5575	0.226
		5	6372	6239	6128	6034	5953	5883	5822	5768	5720	5677	5638	0.199
	Q_s	6	6499	6354	6233	6131	6044	5968	5901	5843	5790	5744	5702	0.178
	634 lb	7	6626	6470	6339	6229	6134	6052	5980	5917	5861	5811	5765	0.161
		8	6753	6585	6445	6326	6225	6137	6060	5992	5931	5877	5829	0.147
	9	6880	6700	6551	6424	6315	6221	6139	6066	6002	5944	5892	0.135	
20 gage	0	5906	5815	5739	5675	5620	5572	5530	5493	5461	5431	5405	0.535	
	0.0358	1	6060	5954	5867	5793	5729	5674	5626	5584	5546	5512	5482	0.415
	Strength / Fastener	2	6213	6094	5995	5911	5839	5777	5723	5674	5632	5593	5559	0.340
	Q_f	3	6367	6234	6124	6030	5949	5880	5819	5765	5717	5674	5636	0.287
	2413 lb	4	6521	6374	6252	6148	6059	5982	5915	5856	5803	5755	5713	0.249
		5	6675	6514	6380	6267	6169	6085	6011	5946	5888	5836	5790	0.219
	Q_s	6	6829	6654	6508	6385	6279	6188	6107	6037	5974	5917	5867	0.196
	770 lb	7	6983	6794	6637	6503	6389	6290	6204	6127	6059	5998	5944	0.178
		8	7137	6934	6765	6622	6499	6393	6300	6218	6145	6079	6021	0.162
	9	7291	7074	6893	6740	6609	6495	6396	6308	6230	6160	6098	0.149	
18 gage	0	6204	6086	5987	5904	5833	5771	5717	5669	5626	5588	5554	0.615	
	0.0474	1	6408	6271	6157	6061	5978	5907	5844	5789	5740	5696	5656	0.478
	Strength / Fastener	2	6612	6456	6327	6218	6124	6042	5971	5909	5853	5803	5758	0.391
	Q_f	3	6815	6642	6497	6374	6269	6178	6099	6028	5966	5910	5860	0.330
	3132 lb	4	7019	6827	6667	6531	6415	6314	6226	6148	6079	6017	5962	0.286
		5	7223	7012	6837	6688	6561	6450	6353	6268	6192	6125	6064	0.253
	Q_s	6	7427	7198	7006	6845	6706	6586	6481	6388	6306	6232	6166	0.226
	1019 lb	7	7631	7383	7176	7001	6852	6722	6608	6508	6419	6339	6267	0.204
		8	7834	7568	7346	7158	6997	6858	6736	6628	6532	6447	6369	0.187
	9	8038	7753	7516	7315	7143	6994	6863	6748	6645	6554	6471	0.172	
16 gage	0	6509	6363	6241	6138	6050	5974	5907	5848	5796	5749	5707	0.691	
	0.0598	1	6766	6597	6456	6336	6234	6145	6068	5999	5938	5884	5835	0.537
	Strength / Fastener	2	7023	6830	6670	6534	6418	6317	6228	6151	6081	6019	5964	0.439
	Q_f	3	7280	7064	6884	6732	6601	6488	6389	6302	6224	6155	6092	0.371
	3867 lb	4	7537	7298	7098	6930	6785	6660	6550	6453	6367	6290	6221	0.322
		5	7794	7532	7313	7127	6969	6831	6711	6604	6510	6425	6349	0.284
	Q_s	6	8052	7765	7527	7325	7152	7002	6871	6756	6653	6561	6478	0.254
	1286 lb	7	8309	7999	7741	7523	7336	7174	7032	6907	6796	6696	6606	0.229
		8	8566	8233	7956	7721	7520	7345	7193	7058	6938	6831	6735	0.209
	9	8823	8467	8170	7919	7703	7517	7353	7209	7081	6967	6864	0.193	

- NOTES**
1. Shaded Area does not conform to SDI maximum fastener spacing of 36" o.c. for spans greater than 5' 0".
 2. See Slab Tables for the maximum unshored spans and slab load capacities.
 3. Canam does not recommend the use of weld washers on deck thicker than or equal to 22 gage.

$$G' = \frac{K_2}{K_4 + 3K_1 L_v} + K_3 \text{ (kips/in)}$$

t	.0295	.0358	.0474	.0598
K_2	870	1056	1398	1764
K_3	2380			

Deck	K_4
B-Lok	3.78

DIAPHRAGM

TABLES



COMPOSITE DECK, B-Lok - Light Weight, Weld Screw

Deck: $F_y = 40$ ksi Fastener Pattern = 36/7
 Concrete: 115 pcf $f'_c = 3$ ksi with 2 1/2" cover over deck
 Fastener Support 5/8" ϕ puddle welds (Q_f)
 Side-Lap # 10 screws (Q_s)

Load Type	ASD Ω	LRFD ϕ
All	3.25 S_u/Ω	0.50 ϕS_n

B-Lok-Floor Composite Deck Slab Diaphragm Table

Deck "t"	Side-Lap Conn. / Span	Nominal Shear Strength (S_n), PLF											K_1	
		Span (L_v), Ft.												
		5.0	5.5	6.0	6.5	7.0	7.5	8.0	8.5	9.0	9.5	10.0		
22 gage	0	4298	4222	4159	4105	4060	4020	3985	3954	3927	3903	3881	0.486	
	0.0295	1	4425	4337	4265	4203	4150	4104	4064	4029	3998	3970	0.377	
	Strength / Fastener	2	4552	4453	4370	4301	4241	4189	4144	4104	4068	4036	4008	0.308
	Q_f	3	4678	4568	4476	4398	4331	4274	4223	4178	4139	4103	4071	0.261
	2010 lb	4	4805	4683	4582	4496	4422	4358	4302	4253	4209	4170	4135	0.226
		5	4932	4799	4687	4593	4513	4443	4382	4328	4280	4237	4198	0.199
		6	5059	4914	4793	4691	4603	4527	4461	4402	4350	4303	4261	0.178
	Q_s	7	5186	5029	4899	4788	4694	4612	4540	4477	4421	4370	4325	0.161
	634 lb	8	5313	5145	5005	4886	4784	4696	4619	4551	4491	4437	4388	0.147
	9	5439	5260	5110	4984	4875	4781	4699	4626	4561	4504	4452	0.135	
20 gage	0	4465	4374	4298	4234	4179	4131	4090	4053	4020	3991	3965	0.535	
	0.0358	1	4619	4514	4427	4353	4289	4234	4186	4143	4106	4072	4042	0.415
	Strength / Fastener	2	4773	4654	4555	4471	4399	4337	4282	4234	4191	4153	4119	0.340
	Q_f	3	4927	4794	4683	4589	4509	4439	4378	4325	4277	4234	4196	0.287
	2413 lb	4	5081	4934	4811	4708	4619	4542	4475	4415	4362	4315	4272	0.249
		5	5235	5074	4940	4826	4729	4645	4571	4506	4448	4396	4349	0.219
		6	5389	5214	5068	4945	4839	4747	4667	4596	4533	4477	4426	0.196
	Q_s	7	5543	5354	5196	5063	4949	4850	4763	4687	4619	4558	4503	0.178
	770 lb	8	5697	5494	5325	5181	5059	4952	4859	4777	4704	4639	4580	0.162
	9	5851	5634	5453	5300	5169	5055	4956	4868	4790	4720	4657	0.149	
18 gage	0	4764	4645	4547	4464	4392	4330	4276	4228	4186	4148	4114	0.615	
	0.0474	1	4967	4831	4717	4620	4538	4466	4404	4348	4299	4255	4216	0.478
	Strength / Fastener	2	5171	5016	4887	4777	4683	4602	4531	4468	4412	4363	4318	0.391
	Q_f	3	5375	5201	5057	4934	4829	4738	4658	4588	4526	4470	4419	0.330
	3132 lb	4	5579	5387	5226	5091	4975	4874	4786	4708	4639	4577	4521	0.286
		5	5783	5572	5396	5248	5120	5010	4913	4828	4752	4684	4623	0.253
		6	5986	5757	5566	5404	5266	5146	5041	4948	4865	4792	4725	0.226
	Q_s	7	6190	5942	5736	5561	5411	5282	5168	5068	4979	4899	4827	0.204
	1019 lb	8	6394	6128	5906	5718	5557	5417	5295	5188	5092	5006	4929	0.187
	9	6598	6313	6076	5875	5703	5553	5423	5307	5205	5113	5031	0.172	
16 gage	0	5068	4922	4801	4698	4610	4534	4467	4408	4355	4308	4266	0.691	
	0.0598	1	5325	5156	5015	4896	4794	4705	4627	4559	4498	4444	4395	0.537
	Strength / Fastener	2	5583	5390	5230	5094	4977	4876	4788	4710	4641	4579	4523	0.439
	Q_f	3	5840	5624	5444	5291	5161	5048	4949	4861	4784	4714	4652	0.371
	3867 lb	4	6097	5858	5658	5489	5345	5219	5110	5013	4927	4850	4780	0.322
		5	6354	6091	5872	5687	5528	5391	5270	5164	5070	4985	4909	0.284
		6	6611	6325	6087	5885	5712	5562	5431	5315	5212	5120	5038	0.254
	Q_s	7	6868	6559	6301	6083	5896	5734	5592	5467	5355	5256	5166	0.229
	1286 lb	8	7125	6793	6515	6280	6079	5905	5752	5618	5498	5391	5295	0.209
	9	7383	7026	6729	6478	6263	6076	5913	5769	5641	5526	5423	0.193	

- NOTES**
1. Shaded Area does not conform to SDI maximum fastener spacing of 36" o.c. for spans greater than 5' 0".
 2. See Slab Tables for the maximum unshored spans and slab load capacities.
 3. Canam does not recommend the use of weld washers on deck thicker than or equal to 22 gage.

$$G' = \frac{K_2}{K_4 + 3K_1 L_v} + K_3 \text{ (kips/in)}$$

t	.0295	.0358	.0474	.0598
K_2	870	1056	1398	1764
K_3	2380			

Deck	K_4
B-Lok	3.78

DIAPHRAGM



FORM DECK, UFS - Normal Weight, Weld Screw

Deck: $F_y = 80$ ksi
Structural Concrete

Fastener Pattern = 35/4

Load Type	ASD Ω	LRFD ϕ
All	3.25	0.50
	S_p/Ω	ϕS_n

145 pcf $f'c = 3$ ksi with 2" cover over deck

Fastener Support 16 gage weld washers w/ 3/8" opening (< 22 ga deck) (Q_s)
 5/8" ϕ puddle welds (\geq 22 ga deck) (Q_s)
 Side-Lap # 10 screws (Q_s)

UFS Form Deck Slab Diaphragm Tables

Deck "t"	Side-Lap Conn. / Span	Nominal Shear Strength (S_n), PLF											K_1	
		Span (L_s), Ft.												
		1.5	2.0	2.5	3.0	3.5	4.0	4.5	5.0	5.5	6.0	6.5		
28 gage	0.0149	0	5114	4816	4638	4519	4434	4370	4320	4281	4248	4221	4198	0.497
		1	5328	4977	4766	4626	4525	4450	4392	4345	4306	4275	4248	0.354
	Q_s (lb)	2	5541	5137	4894	4732	4617	4530	4463	4409	4365	4328	4297	0.275
	1131	3	5755	5297	5022	4839	4708	4610	4534	4473	4423	4381	4346	0.225
	Q_s (lb)	4	5968	5457	5150	4946	4800	4690	4605	4537	4481	4435	4395	0.190
	320	5	6182	5617	5279	5053	4891	4770	4676	4601	4539	4488	4445	0.165
26 gage	0.0179	0	5455	5072	4842	4689	4580	4498	4434	4383	4341	4306	4277	0.545
		1	5711	5264	4996	4817	4690	4594	4519	4460	4411	4370	4336	0.388
	Q_s (lb)	2	5968	5457	5150	4946	4800	4690	4605	4537	4481	4435	4395	0.302
	1455	3	6224	5649	5304	5074	4910	4786	4690	4614	4551	4499	4454	0.247
	Q_s (lb)	4	6481	5841	5458	5202	5019	4882	4776	4691	4621	4563	4514	0.209
	385	5	6737	6034	5612	5330	5129	4979	4861	4768	4691	4627	4573	0.181
24 gage	0.0239	0	6237	5658	5311	5080	4915	4791	4695	4617	4554	4502	4457	0.629
		1	6579	5915	5517	5251	5062	4919	4809	4720	4648	4587	4536	0.449
	Q_s (lb)	2	6922	6172	5722	5423	5208	5048	4923	4823	4741	4673	4615	0.349
	2198	3	7264	6429	5928	5594	5355	5176	5037	4926	4835	4759	4694	0.285
	Q_s (lb)	4	7607	6686	6134	5765	5502	5305	5151	5029	4928	4844	4773	0.241
	514	5	7950	6943	6339	5936	5649	5433	5265	5131	5021	4930	4853	0.209
22 gage	0.0295	0	6445	5815	5437	5184	5004	4869	4764	4680	4611	4554	4505	0.699
		1	6868	6132	5690	5396	5185	5028	4905	4807	4727	4660	4603	0.499
	Q_s (lb)	2	7291	6449	5944	5607	5367	5186	5046	4934	4842	4765	4701	0.387
	2396	3	7714	6766	6198	5819	5548	5345	5187	5061	4957	4871	4798	0.317
	Q_s (lb)	4	8137	7083	6451	6030	5729	5503	5328	5187	5072	4977	4896	0.268
	634	5	8559	7400	6705	6241	5910	5662	5469	5314	5188	5082	4993	0.232
20 gage	0.0358	0	6951	6194	5740	5437	5221	5059	4933	4832	4749	4680	4622	0.770
		1	7465	6579	6048	5694	5441	5251	5104	4986	4889	4809	4741	0.549
	Q_s (lb)	2	7978	6964	6356	5951	5661	5444	5275	5140	5029	4937	4859	0.427
	2877	3	8491	7349	6664	6207	5881	5636	5446	5294	5169	5065	4977	0.349
	Q_s (lb)	4	9004	7734	6972	6464	6101	5829	5617	5448	5309	5194	5096	0.295
	770	5	9517	8119	7280	6720	6321	6021	5788	5602	5449	5322	5214	0.256

NOTES

1. Shaded Area does not conform to SDI maximum fastener spacing of 36" o.c. for spans greater than 5' 0".
2. Values to the right of the bold line exceed the maximum recommended span for multispans conditions. Reference the maximum span table for form deck for spans approaching the bold line.
3. See Slab Tables for the load capacities.
4. Canam does not recommend the use of weld washers on deck thicker than or equal to 22 gage.
5. SDI equations apply to covers ranging from 2" to 6" for structural concrete decks. This table uses the 2" cover to establish a lower limit for diaphragm checks.
6. Q_s = Nominal Shear Capacity of Support Fastener
 Q_s = Nominal Shear Capacity of Side Lap Fastener

$$G' = \frac{K_2}{K_4 + 3K_1L_v} + K_3 \text{ (kips/in)}$$

t	.0149	.0179	.0239	.0295	.0358
K_2	440	528	705	870	1056
K_3	1900				

Deck	K_4
UFS	2.83

TABLES



FORM DECK, UF1X - Normal Weight, Weld Screw

Deck: $F_y = 80$ ksi
Structural Concrete

Fastener Pattern = 27/3

Load Type	ASD Ω	LRFD ϕ
All	3.25	0.50
	S_n/Ω	ϕS_n

145 pcf $f'c = 3$ ksi with 2" cover over deck

Fastener Support 16 gage weld washers w/ 3/8" opening (< 22 ga deck) (Q_t)
5/8" ϕ puddle welds (≥ 22 ga deck) (Q_t)
Side-Lap # 10 screws (Q_s)

UF1X Form Deck Slab Diaphragm Tables

Deck "t"	Side-Lap Conn. / Span	Nominal Shear Strength (S_n), PLF											K_1
		Span (L_v), Ft.											
		1.5	2.0	2.5	3.0	3.5	4.0	4.5	5.0	5.5	6.0	6.5	
26 gage	0	5217	4893	4699	4570	4478	4408	4355	4311	4276	4247	4222	1.009
	1	5473	5086	4853	4698	4588	4505	4440	4388	4346	4311	4281	0.640
	Q_t (lb)	5730	5278	5007	4827	4698	4601	4526	4465	4416	4375	4340	0.469
	1455	5986	5471	5161	4955	4808	4697	4611	4542	4486	4439	4399	0.370
	Q_s (lb)	6243	5663	5315	5083	4917	4793	4697	4619	4556	4503	4459	0.306
385	5	6499	5855	5469	5211	5027	4889	4782	4696	4626	4567	4518	0.260
24 gage	0	5877	5389	5096	4900	4761	4656	4575	4510	4456	4412	4374	1.165
	1	6220	5646	5301	5072	4908	4785	4689	4612	4550	4498	4453	0.740
	Q_t (lb)	6562	5903	5507	5243	5054	4913	4803	4715	4643	4583	4532	0.542
	2198	6905	6160	5712	5414	5201	5041	4917	4818	4737	4669	4611	0.428
	Q_s (lb)	7247	6416	5918	5585	5348	5170	5031	4921	4830	4754	4691	0.353
514	5	7590	6673	6123	5757	5495	5298	5146	5023	4923	4840	4770	0.301
22 gage	0	6053	5521	5201	4988	4836	4722	4633	4562	4504	4456	4415	1.295
	1	6476	5838	5455	5200	5017	4881	4774	4689	4620	4562	4513	0.822
	Q_t (lb)	6899	6155	5709	5411	5199	5039	4915	4816	4735	4667	4610	0.602
	2396	7322	6472	5963	5623	5380	5198	5056	4943	4850	4773	4708	0.475
	Q_s (lb)	7745	6789	6216	5834	5561	5356	5197	5070	4966	4879	4805	0.392
634	5	8168	7107	6470	6045	5742	5515	5338	5197	5081	4984	4903	0.334
20 gage	0	6481	5842	5458	5202	5020	4882	4776	4691	4621	4563	4514	1.426
	1	6994	6226	5766	5459	5239	5075	4947	4845	4761	4691	4632	0.906
	Q_t (lb)	7507	6611	6074	5715	5459	5267	5118	4999	4901	4819	4750	0.663
	2877	8020	6996	6382	5972	5679	5460	5289	5153	5041	4948	4869	0.523
	Q_s (lb)	8533	7381	6689	6228	5899	5652	5460	5306	5181	5076	4987	0.432
770	5	9047	7766	6997	6485	6119	5845	5631	5460	5321	5204	5106	0.368

- NOTES**
1. Shaded Area does not conform to SDI maximum fastener spacing of 36" o.c. for spans greater than 5' 0".
 2. Values to the right of the bold line exceed the maximum recommended span for multispan conditions. Reference the maximum span table for form deck for spans approaching the bold line.
 3. See Slab Tables for the load capacities.
 4. Canam does not recommend the use of weld washers on deck thicker than or equal to 22 gage.
 5. SDI equations apply to covers ranging from 2" to 6" for structural concrete decks. This table uses the 2" cover to establish a lower limit for diaphragm checks.
 6. Q_t = Nominal Shear Capacity of Support Fastener
 Q_s = Nominal Shear Capacity of Side Lap Fastener

$$G' = \frac{K_2}{K_4 + 3K_1 L_v} + K_3 \text{ (kips/in)}$$

t	.0179	.0239	.0295	.0358
K_2	528	705	870	1056
K_3	1900			

Deck	K_4
UF1X	3.15

DIAPHRAGM

TABLES



FORM DECK, UFX - Normal Weight, Weld Screw

Deck: $F_y = 80$ ksi
Structural Concrete

Fastener Pattern = 36/4

Load Type	ASD Ω	LRFD ϕ
All	3.25	0.50
	S_n/Ω	ϕS_n

145 pcf $f'c = 3$ ksi with 2" cover over deck

Fastener Support 16 gage weld washers w/ 3/8" opening (< 22 ga deck) (Q_t)
5/8" ϕ puddle welds (≥ 22 ga deck) (Q_t)
Side-Lap # 10 screws (Q_s)

UFX Form Deck Slab Diaphragm Tables

Deck "t"	Side-Lap Conn. / Span	Nominal Shear Strength (S_n), PLF											K_1	
		Span (L_v), Ft.												
		3.5	4.0	4.5	5.0	5.5	6.0	6.5	7.0	7.5	8.0	8.5		
26 gage	0	4580	4498	4434	4383	4341	4306	4277	4252	4230	4211	4194	0.530	
	1	4690	4594	4519	4460	4411	4370	4336	4307	4281	4259	4239	0.378	
	Q_t (lb)	2	4800	4690	4605	4537	4481	4435	4395	4361	4332	4307	4284	0.293
	1455	3	4910	4786	4690	4614	4551	4499	4454	4416	4384	4355	4329	0.240
	Q_s (lb)	4	5019	4882	4776	4691	4621	4563	4514	4471	4435	4403	4375	0.203
385	5	5129	4979	4861	4768	4691	4627	4573	4526	4486	4451	4420	0.176	
24 gage	0	4915	4791	4695	4617	4554	4502	4457	4419	4386	4357	4332	0.612	
	1	5062	4919	4809	4720	4648	4587	4536	4493	4455	4421	4392	0.436	
	Q_t (lb)	2	5208	5048	4923	4823	4741	4673	4615	4566	4523	4486	4453	0.339
	2198	3	5355	5176	5037	4926	4835	4759	4694	4639	4592	4550	4513	0.277
	Q_s (lb)	4	5502	5305	5151	5029	4928	4844	4773	4713	4660	4614	4573	0.234
514	5	5649	5433	5265	5131	5021	4930	4853	4786	4729	4678	4634	0.203	
22 gage	0	5004	4869	4764	4680	4611	4554	4505	4464	4428	4396	4368	0.680	
	1	5185	5028	4905	4807	4727	4660	4603	4554	4512	4476	4443	0.485	
	Q_t (lb)	2	5367	5186	5046	4934	4842	4765	4701	4645	4597	4555	4518	0.377
	2396	3	5548	5345	5187	5061	4957	4871	4798	4736	4682	4634	4592	0.308
	Q_s (lb)	4	5729	5503	5328	5187	5072	4977	4896	4826	4766	4713	4667	0.260
634	5	5910	5662	5469	5314	5188	5082	4993	4917	4851	4793	4742	0.226	
20 gage	0	5221	5059	4933	4832	4749	4680	4622	4572	4529	4491	4458	0.749	
	1	5441	5251	5104	4986	4889	4809	4741	4682	4632	4587	4548	0.534	
	Q_t (lb)	2	5661	5444	5275	5140	5029	4937	4859	4792	4734	4684	4639	0.415
	2877	3	5881	5636	5446	5294	5169	5065	4977	4902	4837	4780	4729	0.339
	Q_s (lb)	4	6101	5829	5617	5448	5309	5194	5096	5012	4940	4876	4820	0.287
770	5	6321	6021	5788	5602	5449	5322	5214	5122	5042	4972	4911	0.249	

- NOTES**
1. Shaded Area does not conform to SDI maximum fastener spacing of 36" o.c. for spans greater than 5' 0".
 2. Values to the right of the bold line exceed the maximum recommended span for multispan conditions. Reference the maximum span table for form deck for spans approaching the bold line.
 3. See Slab Tables for the load capacities.
 4. Canam does not recommend the use of weld washers on deck thicker than or equal to 22 gage.
 5. SDI equations apply to covers ranging from 2" to 6" for structural concrete decks. This table uses the 2" cover to establish a lower limit for diaphragm checks.
 6. Q_t = Nominal Shear Capacity of Support Fastener
 Q_s = Nominal Shear Capacity of Side Lap Fastener

$$G' = \frac{K_2}{K_4 + 3K_1 L_v} + K_3 \text{ (kips/in)}$$

t	.0179	.0239	.0295	.0358
K_2	528	705	870	1056
K_3	1900			

Deck	K_4
UFX	3.64

TABLES

DIAPHRAGM



FORM DECK, UF2X - Normal Weight, Weld Screw

Deck: $F_y = 80$ ksi
Structural Concrete

Fastener Pattern = 30/3

Load Type	ASD Ω	LRFD ϕ
All	3.25	0.50
	S_n/Ω	ϕS_n

145 pcf $f'c = 3$ ksi with 2" cover over deck

Fastener Support 16 gage weld washers w/ 3/8" opening (< 22 ga deck) (Q_t)
 5/8" ϕ puddle welds (≥ 22 ga deck) (Q_s)
 Side-Lap # 10 screws (Q_s)

UF2X Form Deck Slab Diaphragm Tables

Deck "t"	Side-Lap Conn. / Span	Nominal Shear Strength (S_n), PLF										K_1		
		Span (L_v), Ft.												
		4.5	5.0	5.5	6.0	6.5	7.0	7.5	8.0	8.5	9.0	9.5		
24 gage	0	4588	4521	4467	4422	4383	4350	4322	4297	4275	4256	4238	0.954	
	1	4702	4624	4560	4507	4462	4424	4391	4361	4336	4313	4292	0.626	
	Q_t (lb)	2	4816	4727	4654	4593	4541	4497	4459	4426	4396	4370	4346	0.466
	2198	3	4930	4830	4747	4679	4620	4571	4528	4490	4456	4427	4400	0.371
	Q_s (lb)	4	5044	4932	4841	4764	4700	4644	4596	4554	4517	4484	4454	0.309
514	5	5159	5035	4934	4850	4779	4718	4665	4618	4577	4541	4509	0.264	
22 gage	0	4648	4575	4516	4467	4425	4389	4358	4331	4307	4286	4266	1.059	
	1	4789	4702	4631	4572	4522	4480	4443	4410	4381	4356	4333	0.696	
	Q_t (lb)	2	4930	4829	4747	4678	4620	4570	4527	4489	4456	4426	4400	0.518
	2396	3	5070	4956	4862	4784	4718	4661	4612	4569	4531	4497	4467	0.413
	Q_s (lb)	4	5211	5083	4977	4889	4815	4751	4696	4648	4605	4567	4534	0.343
634	5	5352	5209	5093	4995	4913	4842	4781	4727	4680	4638	4600	0.293	
20 gage	0	4793	4706	4635	4576	4525	4482	4445	4413	4384	4358	4335	1.167	
	1	4964	4860	4775	4704	4644	4592	4548	4509	4474	4444	4416	0.766	
	Q_t (lb)	2	5135	5014	4915	4832	4762	4702	4650	4605	4565	4529	4497	0.571
	2877	3	5306	5168	5055	4960	4881	4812	4753	4701	4655	4615	4578	0.454
	Q_s (lb)	4	5477	5322	5195	5089	4999	4922	4856	4797	4746	4700	4659	0.378
770	5	5648	5476	5335	5217	5118	5032	4958	4894	4837	4786	4740	0.323	
18 gage	0	5052	4939	4847	4770	4705	4649	4601	4558	4521	4488	4458	1.343	
	1	5279	5143	5032	4940	4862	4795	4736	4686	4641	4601	4565	0.882	
	Q_t (lb)	2	5505	5347	5217	5110	5018	4940	4872	4813	4761	4714	4673	0.657
	3734	3	5731	5551	5403	5279	5175	5086	5008	4940	4881	4827	4780	0.523
	Q_s (lb)	4	5958	5754	5588	5449	5332	5231	5144	5068	5001	4941	4887	0.434
1019	5	6184	5958	5773	5619	5489	5377	5280	5195	5120	5054	4994	0.372	

- NOTES
1. Shaded Area does not conform to SDI maximum fastener spacing of 36" o.c. for spans greater than 5' 0".
 2. Values to the right of the bold line exceed the maximum recommended span for multispan conditions. Reference the maximum span table for form deck for spans approaching the bold line.
 3. See Slab Tables for the load capacities.
 4. Canam does not recommend the use of weld washers on deck thicker than or equal to 22 gage.
 5. SDI equations apply to covers ranging from 2" to 6" for structural concrete decks. This table uses the 2" cover to establish a lower limit for diaphragm checks.
 6. Q_t = Nominal Shear Capacity of Support Fastener
 Q_s = Nominal Shear Capacity of Side Lap Fastener

$$G' = \frac{K_2}{K_4 + 3K_1 L_v} + K_3 \text{ (kips/in)}$$

t	.0239	.0295	.0358	.0474
K_2	705	870	1056	1398
K_3	1900			

Deck	K_4
UF2X	3.57



FORM DECK, UFS - Light Weight, Weld Screw

Deck: $F_y = 80$ ksi
Structural Concrete

Fastener Pattern = 35/4

Load Type	ASD	LRFD
	Ω	ϕ
All	3.25	0.50
	S_r/Ω	ϕS_n

115 pcf $f'c = 3$ ksi with 2" cover over deck

Fastener Support 16 gage weld washers w/ 3/8" opening (< 22 ga deck) (Q_s)
5/8" ϕ puddle welds (≥ 22 ga deck) (Q_s)
Side-Lap # 10 screws (Q_s)

UFS Form Deck Slab Diaphragm Tables

Deck "t"	Side-Lap Conn. / Span	Nominal Shear Strength (S_n), PLF											K_1	
		Span (L_v), Ft.												
		1.5	2.0	2.5	3.0	3.5	4.0	4.5	5.0	5.5	6.0	6.5		
28 gage	0.0149	0	3962	3664	3486	3366	3281	3218	3168	3128	3096	3069	3046	0.497
		1	4175	3824	3614	3473	3373	3298	3239	3192	3154	3122	3095	0.354
	Q_s (lb)	2	4389	3985	3742	3580	3465	3378	3310	3257	3212	3176	3145	0.275
	1131	3	4603	4145	3870	3687	3556	3458	3382	3321	3271	3229	3194	0.225
	Q_s (lb)	4	4816	4305	3998	3794	3648	3538	3453	3385	3329	3282	3243	0.190
	320	5	5030	4465	4126	3900	3739	3618	3524	3449	3387	3336	3292	0.165
26 gage	0.0179	0	4302	3919	3690	3537	3427	3345	3282	3230	3189	3154	3124	0.545
		1	4559	4112	3844	3665	3537	3442	3367	3307	3259	3218	3184	0.388
	Q_s (lb)	2	4815	4304	3998	3793	3647	3538	3453	3384	3329	3282	3243	0.302
	1455	3	5072	4497	4152	3922	3757	3634	3538	3461	3399	3346	3302	0.247
	Q_s (lb)	4	5329	4689	4306	4050	3867	3730	3624	3538	3469	3411	3361	0.209
	385	5	5585	4882	4460	4178	3977	3826	3709	3615	3539	3475	3421	0.181
24 gage	0.0239	0	5084	4506	4159	3928	3763	3639	3542	3465	3402	3349	3305	0.629
		1	5427	4763	4365	4099	3909	3767	3656	3568	3495	3435	3384	0.449
	Q_s (lb)	2	5770	5020	4570	4270	4056	3896	3771	3671	3589	3521	3463	0.349
	2198	3	6112	5277	4776	4442	4203	4024	3885	3773	3682	3606	3542	0.285
	Q_s (lb)	4	6455	5534	4981	4613	4350	4152	3999	3876	3776	3692	3621	0.241
	514	5	6797	5791	5187	4784	4497	4281	4113	3979	3869	3778	3700	0.209
22 gage	0.0295	0	5293	4663	4284	4032	3852	3717	3612	3528	3459	3402	3353	0.699
		1	5716	4980	4538	4244	4033	3875	3753	3655	3574	3507	3451	0.499
	Q_s (lb)	2	6139	5297	4792	4455	4214	4034	3894	3781	3690	3613	3548	0.387
	2396	3	6562	5614	5045	4666	4396	4193	4035	3908	3805	3719	3646	0.317
	Q_s (lb)	4	6984	5931	5299	4878	4577	4351	4176	4035	3920	3824	3743	0.268
	634	5	7407	6248	5553	5089	4758	4510	4317	4162	4036	3930	3841	0.232
20 gage	0.0358	0	5799	5042	4588	4285	4069	3907	3781	3680	3597	3528	3470	0.770
		1	6312	5427	4896	4542	4289	4099	3952	3834	3737	3656	3588	0.549
	Q_s (lb)	2	6825	5812	5204	4798	4509	4292	4123	3987	3877	3785	3707	0.427
	2877	3	7339	6197	5512	5055	4729	4484	4294	4141	4017	3913	3825	0.349
	Q_s (lb)	4	7852	6582	5820	5311	4949	4676	4465	4295	4157	4041	3944	0.295
	770	5	8365	6966	6127	5568	5168	4869	4636	4449	4297	4170	4062	0.256

NOTES

1. Shaded Area does not conform to SDI maximum fastener spacing of 36" o.c. for spans greater than 5' 0".
2. Values to the right of the bold line exceed the maximum recommended span for multispans conditions. Reference the maximum span table for form deck for spans approaching the bold line.
3. See Slab Tables for the load capacities.
4. Canam does not recommend the use of weld washers on deck thicker than or equal to 22 gage.
5. SDI equations apply to covers ranging from 2" to 6" for structural concrete decks. This table uses the 2" cover to establish a lower limit for diaphragm checks.
6. Q_s = Nominal Shear Capacity of Support Fastener
 Q_s = Nominal Shear Capacity of Side Lap Fastener

$$G' = \frac{K_2}{K_4 + 3K_1L_v} + K_3 \text{ (kips/in)}$$

t	.0149	.0179	.0239	.0295	.0358
K_2	440	528	705	870	1056
K_3	1900				

Deck	K_4
UFS	2.83

TABLES

FORM DECK, UF1X - Light Weight, Weld Screw

Deck: $F_y = 80$ ksi
Structural Concrete

Fastener Pattern = 27/3

Load Type	ASD Ω	LRFD ϕ
All	3.25	0.50
	S_n/Ω	ϕS_n

115 pcf $f'c = 3$ ksi with 2" cover over deck

Fastener Support 16 gage weld washers w/ 3/8" opening (< 22 ga deck) (Q_t)
5/8" ϕ puddle welds (≥ 22 ga deck) (Q_t)
Side-Lap # 10 screws (Q_s)

UF1X Form Deck Slab Diaphragm Tables

Deck "t"	Side-Lap Conn. / Span	Nominal Shear Strength (S_n), PLF										K_1		
		Span (L_v), Ft.												
		1.5	2.0	2.5	3.0	3.5	4.0	4.5	5.0	5.5	6.0	6.5		
26 gage	0	4064	3741	3547	3418	3325	3256	3202	3159	3124	3094	3070	1.009	
	1	4321	3933	3701	3546	3435	3352	3288	3236	3194	3159	3129	0.640	
	Q_t (lb)	2	4577	4126	3855	3674	3545	3449	3373	3313	3264	3223	3188	0.469
	1455	3	4834	4318	4009	3803	3655	3545	3459	3390	3334	3287	3247	0.370
	Q_s (lb)	4	5091	4511	4163	3931	3765	3641	3544	3467	3404	3351	3306	0.306
385	5	5347	4703	4317	4059	3875	3737	3630	3544	3474	3415	3366	0.260	
24 gage	0	4725	4236	3943	3748	3608	3504	3422	3357	3304	3260	3222	1.165	
	1	5068	4493	4149	3919	3755	3632	3537	3460	3397	3345	3301	0.740	
	Q_t (lb)	2	5410	4750	4355	4091	3902	3761	3651	3563	3491	3431	3380	0.542
	2198	3	5753	5007	4560	4262	4049	3889	3765	3666	3584	3517	3459	0.428
	Q_s (lb)	4	6095	5264	4766	4433	4196	4018	3879	3768	3678	3602	3538	0.353
514	5	6438	5521	4971	4604	4343	4146	3993	3871	3771	3688	3617	0.301	
22 gage	0	4901	4369	4049	3836	3684	3570	3481	3410	3352	3304	3263	1.295	
	1	5324	4686	4303	4048	3865	3728	3622	3537	3467	3409	3360	0.822	
	Q_t (lb)	2	5747	5003	4557	4259	4046	3887	3763	3664	3583	3515	3458	0.602
	2396	3	6170	5320	4810	4470	4228	4046	3904	3791	3698	3621	3555	0.475
	Q_s (lb)	4	6592	5637	5064	4682	4409	4204	4045	3918	3813	3726	3653	0.392
634	5	7015	5954	5318	4893	4590	4363	4186	4044	3929	3832	3751	0.334	
20 gage	0	5329	4689	4306	4050	3867	3730	3624	3538	3469	3411	3361	1.426	
	1	5842	5074	4614	4306	4087	3923	3795	3692	3609	3539	3480	0.906	
	Q_t (lb)	2	6355	5459	4921	4563	4307	4115	3966	3846	3749	3667	3598	0.663
	2877	3	6868	5844	5229	4820	4527	4307	4137	4000	3888	3795	3717	0.523
	Q_s (lb)	4	7381	6229	5537	5076	4747	4500	4308	4154	4028	3924	3835	0.432
770	5	7894	6614	5845	5333	4967	4692	4479	4308	4168	4052	3953	0.368	

- NOTES
1. Shaded Area does not conform to SDI maximum fastener spacing of 36" o.c. for spans greater than 5' 0".
 2. Values to the right of the bold line exceed the maximum recommended span for multispan conditions. Reference the maximum span table for form deck for spans approaching the bold line.
 3. See Slab Tables for the load capacities.
 4. Canam does not recommend the use of weld washers on deck thicker than or equal to 22 gage.
 5. SDI equations apply to covers ranging from 2" to 6" for structural concrete decks. This table uses the 2" cover to establish a lower limit for diaphragm checks.
 6. Q_t = Nominal Shear Capacity of Support Fastener
 Q_s = Nominal Shear Capacity of Side Lap Fastener

$$G' = \frac{K_2}{K_4 + 3K_1 L_v} + K_3 \text{ (kips/in)}$$

t	.0179	.0239	.0295	.0358
K_2	528	705	870	1056
K_3	1900			

Deck	K_4
UF1X	3.15



FORM DECK, UFX - Light Weight, Weld Screw

Deck: $F_y = 80$ ksi
Structural Concrete

Fastener Pattern = 36/4

Load Type	ASD Ω	LRFD ϕ
All	3.25	0.50
	S_n/Ω	ϕS_n

115 pcf $f'c = 3$ ksi with 2" cover over deck

Fastener Support 16 gage weld washers w/ 3/8" opening (< 22 ga deck) (Q_t)
 5/8" ϕ puddle welds (≥ 22 ga deck) (Q_t)
 Side-Lap # 10 screws (Q_s)

UFX Form Deck Slab Diaphragm Tables

Deck "t"	Side-Lap Conn. / Span	Nominal Shear Strength (S_n), PLF											K_1
		Span (L_v), Ft.											
		3.5	4.0	4.5	5.0	5.5	6.0	6.5	7.0	7.5	8.0	8.5	
26 gage	0	3427	3345	3282	3230	3189	3154	3124	3099	3077	3058	3041	0.530
	1	3537	3442	3367	3307	3259	3218	3184	3154	3129	3106	3087	0.378
	Q_t (lb)	3647	3538	3453	3384	3329	3282	3243	3209	3180	3154	3132	0.293
	1455	3757	3634	3538	3461	3399	3346	3302	3264	3231	3203	3177	0.240
	Q_s (lb)	3867	3730	3624	3538	3469	3411	3361	3319	3283	3251	3222	0.203
385	3977	3826	3709	3615	3539	3475	3421	3374	3334	3299	3268	0.176	
24 gage	0	3763	3639	3542	3465	3402	3349	3305	3267	3234	3205	3179	0.612
	1	3909	3767	3656	3568	3495	3435	3384	3340	3302	3269	3240	0.436
	Q_t (lb)	4056	3896	3771	3671	3589	3521	3463	3414	3371	3333	3300	0.339
	2198	4203	4024	3885	3773	3682	3606	3542	3487	3439	3398	3361	0.277
	Q_s (lb)	4350	4152	3999	3876	3776	3692	3621	3560	3508	3462	3421	0.234
514	4497	4281	4113	3979	3869	3778	3700	3634	3576	3526	3482	0.203	
22 gage	0	3852	3717	3612	3528	3459	3402	3353	3312	3276	3244	3216	0.680
	1	4033	3875	3753	3655	3574	3507	3451	3402	3360	3323	3291	0.485
	Q_t (lb)	4214	4034	3894	3781	3690	3613	3548	3493	3445	3403	3365	0.377
	2396	4396	4193	4035	3908	3805	3719	3646	3583	3529	3482	3440	0.308
	Q_s (lb)	4577	4351	4176	4035	3920	3824	3743	3674	3614	3561	3515	0.260
634	4758	4510	4317	4162	4036	3930	3841	3765	3698	3640	3589	0.226	
20 gage	0	4069	3907	3781	3680	3597	3528	3470	3420	3377	3339	3306	0.749
	1	4289	4099	3952	3834	3737	3656	3588	3530	3479	3435	3396	0.534
	Q_t (lb)	4509	4292	4123	3987	3877	3785	3707	3640	3582	3531	3487	0.415
	2877	4729	4484	4294	4141	4017	3913	3825	3750	3685	3628	3577	0.339
	Q_s (lb)	4949	4676	4465	4295	4157	4041	3944	3860	3787	3724	3668	0.287
770	5168	4869	4636	4449	4297	4170	4062	3970	3890	3820	3758	0.249	

- NOTES**
1. Shaded Area does not conform to SDI maximum fastener spacing of 36" o.c. for spans greater than 5' 0".
 2. Values to the right of the bold line exceed the maximum recommended span for multispan conditions. Reference the maximum span table for form deck for spans approaching the bold line.
 3. See Slab Tables for the load capacities.
 4. Canam does not recommend the use of weld washers on deck thicker than or equal to 22 gage.
 5. SDI equations apply to covers ranging from 2" to 6" for structural concrete decks. This table uses the 2" cover to establish a lower limit for diaphragm checks.
 6. Q_t = Nominal Shear Capacity of Support Fastener
 Q_s = Nominal Shear Capacity of Side Lap Fastener

$$G' = \frac{K_2}{K_4 + 3K_1 L_v} + K_3 \text{ (kips/in)}$$

t	.0179	.0239	.0295	.0358
K_2	528	705	870	1056
K_3	1900			

Deck	K_4
UFX	3.64

TABLES



FORM DECK, UF2X - Light Weight, Weld Screw

Deck: $F_y = 80$ ksi

Fastener Pattern = 30/3

Structural Concrete

Load Type	ASD Ω	LRFD ϕ
All	3.25	0.50
	S_n/Ω	ϕS_n

115 pcf $f'c = 3$ ksi with 2" cover over deck

Fastener Support 16 gage weld washers w/ 3/8" opening (< 22 ga deck) (Q_t)
 5/8" ϕ puddle welds (≥ 22 ga deck) (Q_s)
 Side-Lap # 10 screws (Q_s)

UF2X Form Deck Slab Diaphragm Tables

Deck "t"	Side-Lap Conn. / Span	Nominal Shear Strength (S_n), PLF											K_1
		Span (L_v), Ft.											
		4.5	5.0	5.5	6.0	6.5	7.0	7.5	8.0	8.5	9.0	9.5	
24 gage	0	3435	3369	3315	3269	3231	3198	3170	3145	3123	3103	3086	0.954
	1	3550	3472	3408	3355	3310	3272	3238	3209	3183	3160	3140	0.626
	Q_t (lb)	3664	3575	3502	3441	3389	3345	3307	3273	3244	3217	3194	0.466
	2198	3778	3677	3595	3526	3468	3418	3375	3338	3304	3275	3248	0.371
	Q_s (lb)	3892	3780	3688	3612	3547	3492	3444	3402	3365	3332	3302	0.309
514	4006	3883	3782	3698	3626	3565	3512	3466	3425	3389	3356	0.264	
22 gage	0	3495	3423	3364	3314	3273	3237	3206	3179	3155	3133	3114	1.059
	1	3636	3550	3479	3420	3370	3327	3290	3258	3229	3204	3181	0.696
	Q_t (lb)	3777	3677	3594	3526	3468	3418	3375	3337	3304	3274	3248	0.518
	2396	3918	3803	3710	3631	3565	3509	3459	3416	3378	3345	3314	0.413
	Q_s (lb)	4059	3930	3825	3737	3663	3599	3544	3496	3453	3415	3381	0.343
634	4200	4057	3940	3843	3760	3690	3629	3575	3528	3486	3448	0.293	
20 gage	0	3641	3554	3483	3423	3373	3330	3293	3260	3232	3206	3183	1.167
	1	3812	3708	3623	3552	3492	3440	3396	3356	3322	3291	3264	0.766
	Q_t (lb)	3983	3862	3762	3680	3610	3550	3498	3453	3413	3377	3345	0.571
	2877	4154	4016	3902	3808	3728	3660	3601	3549	3503	3463	3426	0.454
	Q_s (lb)	4325	4170	4042	3936	3847	3770	3703	3645	3594	3548	3507	0.378
770	4496	4323	4182	4065	3965	3880	3806	3741	3684	3634	3588	0.323	
18 gage	0	3900	3787	3695	3618	3553	3497	3448	3406	3369	3335	3306	1.343
	1	4126	3991	3880	3787	3709	3642	3584	3533	3489	3449	3413	0.882
	Q_t (lb)	4353	4195	4065	3957	3866	3788	3720	3661	3608	3562	3520	0.657
	3734	4579	4398	4250	4127	4023	3933	3856	3788	3728	3675	3628	0.523
	Q_s (lb)	4806	4602	4436	4297	4180	4079	3992	3916	3848	3788	3735	0.434
1019	5032	4806	4621	4467	4336	4225	4128	4043	3968	3902	3842	0.372	

- NOTES
1. Shaded Area does not conform to SDI maximum fastener spacing of 36" o.c. for spans greater than 5' 0".
 2. Values to the right of the bold line exceed the maximum recommended span for multispan conditions. Reference the maximum span table for form deck for spans approaching the bold line.
 3. See Slab Tables for the load capacities.
 4. Canam does not recommend the use of weld washers on deck thicker than or equal to 22 gage.
 5. SDI equations apply to covers ranging from 2" to 6" for structural concrete decks. This table uses the 2" cover to establish a lower limit for diaphragm checks.
 6. Q_t = Nominal Shear Capacity of Support Fastener
 Q_s = Nominal Shear Capacity of Side Lap Fastener

$$G' = \frac{K_2}{K_4 + 3K_1 L_v} + K_3 \text{ (kips/in)}$$

t	.0239	.0295	.0358	.0474
K_2	705	870	1056	1398
K_3	1900			

Deck	K_4
UF2X	3.57

TABLES



FORM DECK, UFSV - Insulating Fill Type I, Weld Screw

Deck: $F_y = 80$ ksi
Type I Insulating Concrete

Fastener Pattern = 35/4

Load Type	ASD Ω	LRFD ϕ
All	3.25	0.50
	S_n/Ω	ϕS_n

30 pcf $f'c = 125$ psi with 2 1/2" cover over deck

Fastener Support 16 gage weld washers w/ 3/8" opening (< 22 ga deck) (Q_s)
 5/8" ϕ puddle welds (≥ 22 ga deck) (Q_s)
 Side-Lap # 10 screws (Q_s)

UFSV Form Deck Slab Diaphragm Tables

Deck "t"	Side-Lap Conn. / Span	Nominal Shear Strength (S_n), PLF										K_1		
		Span (L_v), Ft.												
		1.5	2.0	2.5	3.0	3.5	4.0	4.5	5.0	5.5	6.0	6.5		
28 gage	0.0149	0	1638	1340	1162	1043	957	894	844	804	772	745	722	0.497
		1	1851	1500	1290	1149	1049	974	915	868	830	798	771	0.354
	Q_s (lb)	2	2065	1661	1418	1256	1141	1054	986	933	888	852	821	0.275
	1131	3	2279	1821	1546	1363	1232	1134	1058	997	947	905	870	0.225
	Q_s (lb)	4	2492	1981	1674	1470	1324	1214	1129	1061	1005	958	919	0.190
320	5	2706	2141	1802	1576	1415	1294	1200	1125	1063	1012	968	0.165	
26 gage	0.0179	0	1978	1596	1366	1213	1103	1021	958	907	865	830	801	0.545
		1	2235	1788	1520	1341	1213	1118	1043	984	935	894	860	0.388
	Q_s (lb)	2	2491	1980	1674	1469	1323	1214	1129	1060	1005	958	919	0.302
	1455	3	2748	2173	1828	1598	1433	1310	1214	1137	1075	1022	978	0.247
	Q_s (lb)	4	3005	2365	1982	1726	1543	1406	1300	1214	1145	1087	1037	0.209
385	5	3261	2558	2136	1854	1653	1502	1385	1291	1215	1151	1097	0.181	
24 gage	0.0239	0	2760	2182	1835	1604	1439	1315	1218	1141	1078	1026	981	0.629
		1	3103	2439	2041	1775	1585	1443	1332	1244	1172	1111	1060	0.449
	Q_s (lb)	2	3446	2696	2246	1946	1732	1572	1447	1347	1265	1197	1139	0.349
	2198	3	3788	2953	2452	2118	1879	1700	1561	1450	1358	1282	1218	0.285
	Q_s (lb)	4	4131	3210	2657	2289	2026	1829	1675	1552	1452	1368	1297	0.241
514	5	4473	3467	2863	2460	2173	1957	1789	1655	1545	1454	1376	0.209	
22 gage	0.0295	0	2969	2339	1960	1708	1528	1393	1288	1204	1135	1078	1029	0.699
		1	3392	2656	2214	1920	1709	1551	1429	1331	1250	1183	1127	0.499
	Q_s (lb)	2	3815	2973	2468	2131	1890	1710	1570	1457	1366	1289	1224	0.387
	2396	3	4238	3290	2721	2342	2072	1869	1711	1584	1481	1395	1322	0.317
	Q_s (lb)	4	4660	3607	2975	2554	2253	2027	1852	1711	1596	1501	1419	0.268
634	5	5083	3924	3229	2765	2434	2186	1993	1838	1712	1606	1517	0.232	
20 gage	0.0358	0	3475	2718	2264	1961	1745	1583	1457	1356	1273	1204	1146	0.770
		1	3988	3103	2572	2218	1965	1775	1628	1510	1413	1333	1264	0.549
	Q_s (lb)	2	4502	3488	2880	2474	2185	1968	1799	1664	1553	1461	1383	0.427
	2877	3	5015	3873	3188	2731	2405	2160	1970	1817	1693	1589	1501	0.349
	Q_s (lb)	4	5528	4258	3496	2987	2625	2352	2141	1971	1833	1717	1620	0.295
770	5	6041	4642	3803	3244	2845	2545	2312	2125	1973	1846	1738	0.256	

NOTES

1. Shaded Area does not conform to SDI maximum fastener spacing of 36" o.c. for spans greater than 5' 0".
2. Values to the right of the bold line exceed the maximum recommended span for multispan conditions. Values neglect slab stiffness of fill and are based on a 150 lb/ft of width concentrated load producing L/240 deflection.
3. See Slab Tables for the load capacities.
4. Canam does not recommend the use of weld washers on deck thicker than or equal to 22 gage.
5. SDI recommends 2 1/2" as the minimum cover for insulating concrete decks. This table uses the 2 1/2" cover to establish a lower limit for diaphragm checks.
6. Density is presented as an order of magnitude and does not affect the shear strength for insulating fill; f'_c is critical.
7. Q_s = Nominal Shear Capacity of Support Fastener
 Q_s = Nominal Shear Capacity of Side Lap Fastener

$$G' = \frac{K_2}{K_4 + 3K_1 L_v} + K_3 \text{ (kips/in)}$$

t	.0149	.0179	.0239	.0295	.0358
K_2	440	528	705	870	1056
K_3	260				

Deck	K_4
UFSV	2.83

TABLES



FORM DECK, UF1XV - Insulating Fill Type I, Weld Screw

Deck: $F_y = 80$ ksi
Type I Insulating Concrete

Fastener Pattern = 27/3

Load Type	ASD Ω	LRFD ϕ
All	3.25	0.50
	S_n/Ω	ϕS_n

30 pcf $f'_c = 125$ psi with 2 1/2" cover over deck

Fastener Support 16 gage weld washers w/ 3/8" opening (< 22 ga deck) (Q_t)
 5/8" ϕ puddle welds (≥ 22 ga deck) (Q_d)
 Side-Lap # 10 screws (Q_s)

UF1XV Form Deck Slab Diaphragm Tables

Deck "t"	Side-Lap Conn. / Span	Nominal Shear Strength (S_n), PLF											K_1																																																																																																																																																																																																																																												
		Span (L_v), Ft.																																																																																																																																																																																																																																																							
		1.5	2.0	2.5	3.0	3.5	4.0	4.5	5.0	5.5	6.0	6.5																																																																																																																																																																																																																																													
26 gage	0	1740	1417	1223	1094	1001	932	878	835	800	771	746	1.009																																																																																																																																																																																																																																												
	1	1997	1610	1377	1222	1111	1028	964	912	870	835	805	0.640																																																																																																																																																																																																																																												
	Q_t (lb)	2254	1802	1531	1350	1221	1125	1049	989	940	899	864	0.469																																																																																																																																																																																																																																												
	1455	2510	1994	1685	1479	1331	1221	1135	1066	1010	963	923	0.370																																																																																																																																																																																																																																												
	Q_s (lb)	2767	2187	1839	1607	1441	1317	1220	1143	1080	1027	982	0.306																																																																																																																																																																																																																																												
385	3023	2379	1993	1735	1551	1413	1306	1220	1150	1091	1042	0.260	24 gage	0	2401	1913	1619	1424	1285	1180	1098	1033	980	936	898	1.165	1	2744	2169	1825	1595	1431	1308	1213	1136	1073	1021	977	0.740	Q_t (lb)	3086	2426	2031	1767	1578	1437	1327	1239	1167	1107	1056	0.542	2198	3429	2683	2236	1938	1725	1565	1441	1342	1260	1193	1135	0.428	Q_s (lb)	3771	2940	2442	2109	1872	1694	1555	1444	1354	1278	1214	0.353	514	4114	3197	2647	2281	2019	1822	1669	1547	1447	1364	1293	0.301	22 gage	0	2577	2045	1725	1512	1360	1246	1157	1086	1028	980	939	1.295	1	3000	2362	1979	1724	1541	1405	1298	1213	1143	1085	1036	0.822	Q_t (lb)	3423	2679	2233	1935	1722	1563	1439	1340	1259	1191	1134	0.602	2396	3846	2996	2486	2146	1904	1722	1580	1467	1374	1297	1231	0.475	Q_s (lb)	4268	3313	2740	2358	2085	1880	1721	1594	1489	1403	1329	0.392	634	4691	3630	2994	2569	2266	2039	1862	1720	1605	1508	1427	0.334	20 gage	0	3005	2365	1982	1726	1543	1406	1300	1214	1145	1087	1037	1.426	1	3518	2750	2290	1983	1763	1599	1471	1368	1285	1215	1156	0.906	Q_t (lb)	4031	3135	2597	2239	1983	1791	1642	1522	1425	1343	1274	0.663	2877	4544	3520	2905	2496	2203	1984	1813	1676	1565	1471	1393	0.523	Q_s (lb)	5057	3905	3213	2752	2423	2176	1984	1830	1704	1600	1511	0.432	770	5570	4290	3521	3009	2643	2368	2155	1984	1844	1728	1629	0.368
24 gage	0	2401	1913	1619	1424	1285	1180	1098	1033	980	936	898		1.165																																																																																																																																																																																																																																											
	1	2744	2169	1825	1595	1431	1308	1213	1136	1073	1021	977		0.740																																																																																																																																																																																																																																											
	Q_t (lb)	3086	2426	2031	1767	1578	1437	1327	1239	1167	1107	1056		0.542																																																																																																																																																																																																																																											
	2198	3429	2683	2236	1938	1725	1565	1441	1342	1260	1193	1135		0.428																																																																																																																																																																																																																																											
	Q_s (lb)	3771	2940	2442	2109	1872	1694	1555	1444	1354	1278	1214	0.353																																																																																																																																																																																																																																												
514	4114	3197	2647	2281	2019	1822	1669	1547	1447	1364	1293	0.301	22 gage	0	2577	2045	1725	1512	1360	1246	1157	1086	1028	980	939	1.295	1	3000	2362	1979	1724	1541	1405	1298	1213	1143	1085	1036	0.822	Q_t (lb)	3423	2679	2233	1935	1722	1563	1439	1340	1259	1191	1134	0.602	2396	3846	2996	2486	2146	1904	1722	1580	1467	1374	1297	1231	0.475	Q_s (lb)	4268	3313	2740	2358	2085	1880	1721	1594	1489	1403	1329	0.392	634	4691	3630	2994	2569	2266	2039	1862	1720	1605	1508	1427	0.334	20 gage	0	3005	2365	1982	1726	1543	1406	1300	1214	1145	1087	1037	1.426	1	3518	2750	2290	1983	1763	1599	1471	1368	1285	1215	1156	0.906	Q_t (lb)	4031	3135	2597	2239	1983	1791	1642	1522	1425	1343	1274	0.663	2877	4544	3520	2905	2496	2203	1984	1813	1676	1565	1471	1393	0.523	Q_s (lb)	5057	3905	3213	2752	2423	2176	1984	1830	1704	1600	1511	0.432	770	5570	4290	3521	3009	2643	2368	2155	1984	1844	1728	1629	0.368																																																																															
22 gage	0	2577	2045	1725	1512	1360	1246	1157	1086	1028	980	939		1.295																																																																																																																																																																																																																																											
	1	3000	2362	1979	1724	1541	1405	1298	1213	1143	1085	1036		0.822																																																																																																																																																																																																																																											
	Q_t (lb)	3423	2679	2233	1935	1722	1563	1439	1340	1259	1191	1134		0.602																																																																																																																																																																																																																																											
	2396	3846	2996	2486	2146	1904	1722	1580	1467	1374	1297	1231		0.475																																																																																																																																																																																																																																											
	Q_s (lb)	4268	3313	2740	2358	2085	1880	1721	1594	1489	1403	1329	0.392																																																																																																																																																																																																																																												
634	4691	3630	2994	2569	2266	2039	1862	1720	1605	1508	1427	0.334	20 gage	0	3005	2365	1982	1726	1543	1406	1300	1214	1145	1087	1037	1.426	1	3518	2750	2290	1983	1763	1599	1471	1368	1285	1215	1156	0.906	Q_t (lb)	4031	3135	2597	2239	1983	1791	1642	1522	1425	1343	1274	0.663	2877	4544	3520	2905	2496	2203	1984	1813	1676	1565	1471	1393	0.523	Q_s (lb)	5057	3905	3213	2752	2423	2176	1984	1830	1704	1600	1511	0.432	770	5570	4290	3521	3009	2643	2368	2155	1984	1844	1728	1629	0.368																																																																																																																																																														
20 gage	0	3005	2365	1982	1726	1543	1406	1300	1214	1145	1087	1037		1.426																																																																																																																																																																																																																																											
	1	3518	2750	2290	1983	1763	1599	1471	1368	1285	1215	1156		0.906																																																																																																																																																																																																																																											
	Q_t (lb)	4031	3135	2597	2239	1983	1791	1642	1522	1425	1343	1274		0.663																																																																																																																																																																																																																																											
	2877	4544	3520	2905	2496	2203	1984	1813	1676	1565	1471	1393		0.523																																																																																																																																																																																																																																											
	Q_s (lb)	5057	3905	3213	2752	2423	2176	1984	1830	1704	1600	1511	0.432																																																																																																																																																																																																																																												
770	5570	4290	3521	3009	2643	2368	2155	1984	1844	1728	1629	0.368																																																																																																																																																																																																																																													

NOTES

1. Shaded Area does not conform to SDI maximum fastener spacing of 36" o.c. for spans greater than 5' 0".
2. Values to the right of the bold line exceed the maximum recommended span for multispan conditions. Values neglect slab stiffness of fill and are based on a 150 lb/ft of width concentrated load producing L/240 deflection.
3. See Slab Tables for the load capacities.
4. Canam does not recommend the use of weld washers on deck thicker than or equal to 22 gage.
5. SDI recommends 2 1/2" as the minimum cover for insulating concrete decks. This table uses the 2 1/2" cover to establish a lower limit for diaphragm checks.
6. Density is presented as an order of magnitude and does not affect the shear strength for insulating fill; f'_c is critical.
7. Q_t = Nominal Shear Capacity of Support Fastener
 Q_s = Nominal Shear Capacity of Side Lap Fastener

$$G' = \frac{K_2}{K_4 + 3K_1 L_v} + K_3 \text{ (kips/in)}$$

t	.0179	.0239	.0295	.0358
K_2	528	705	870	1056
K_3	260			

Deck	K_4
UF1XV	3.15

TABLES



FORM DECK, UFXV - Insulating Fill Type I, Weld Screw

Deck: $F_y = 80$ ksi
Type I Insulating Concrete

Fastener Pattern = 36/4

Load Type	ASD Ω	LRFD ϕ
All	3.25	0.50
	S_u/Ω	ϕS_n

30 pcf $f'c = 125$ psi with 2 1/2" cover over deck

Fastener Support 16 gage weld washers w/ 3/8" opening (< 22 ga deck) (Q_t)
 5/8" ϕ puddle welds (≥ 22 ga deck) (Q_t)
 Side-Lap # 10 screws (Q_s)

UFXV Form Deck Slab Diaphragm Tables

Deck "t"	Side-Lap Conn. / Span	Nominal Shear Strength (S_n), PLF											K_1
		Span (L_v), Ft.											
		3.5	4.0	4.5	5.0	5.5	6.0	6.5	7.0	7.5	8.0	8.5	
26 gage	0	1103	1021	958	907	865	830	801	775	753	734	717	0.530
	1	1213	1118	1043	984	935	894	860	830	805	782	763	0.378
	Q_t (lb)	1323	1214	1129	1060	1005	958	919	885	856	831	808	0.293
	1455	1433	1310	1214	1137	1075	1022	978	940	907	879	853	0.240
	Q_s (lb)	1543	1406	1300	1214	1145	1087	1037	995	959	927	899	0.203
385	1653	1502	1385	1291	1215	1151	1097	1050	1010	975	944	0.176	
24 gage	0	1439	1315	1218	1141	1078	1026	981	943	910	881	855	0.612
	1	1585	1443	1332	1244	1172	1111	1060	1016	978	945	916	0.436
	Q_t (lb)	1732	1572	1447	1347	1265	1197	1139	1090	1047	1009	976	0.339
	2198	1879	1700	1561	1450	1358	1282	1218	1163	1115	1074	1037	0.277
	Q_s (lb)	2026	1829	1675	1552	1452	1368	1297	1237	1184	1138	1097	0.234
514	2173	1957	1789	1655	1545	1454	1376	1310	1252	1202	1158	0.203	
22 gage	0	1528	1393	1288	1204	1135	1078	1029	988	952	920	892	0.680
	1	1709	1551	1429	1331	1250	1183	1127	1078	1036	999	967	0.485
	Q_t (lb)	1890	1710	1570	1457	1366	1289	1224	1169	1121	1079	1041	0.377
	2396	2072	1869	1711	1584	1481	1395	1322	1259	1205	1158	1116	0.308
	Q_s (lb)	2253	2027	1852	1711	1596	1501	1419	1350	1290	1237	1191	0.260
634	2434	2186	1993	1838	1712	1606	1517	1441	1374	1316	1265	0.226	
20 gage	0	1745	1583	1457	1356	1273	1204	1146	1096	1053	1015	982	0.749
	1	1965	1775	1628	1510	1413	1333	1264	1206	1155	1111	1072	0.534
	Q_t (lb)	2185	1968	1799	1664	1553	1461	1383	1316	1258	1207	1163	0.415
	2877	2405	2160	1970	1817	1693	1589	1501	1426	1361	1304	1253	0.339
	Q_s (lb)	2625	2352	2141	1971	1833	1717	1620	1536	1463	1400	1344	0.287
770	2845	2545	2312	2125	1973	1846	1738	1646	1566	1496	1434	0.249	

NOTES

1. Shaded Area does not conform to SDI maximum fastener spacing of 36" o.c. for spans greater than 5' 0".
2. Values to the right of the bold line exceed the maximum recommended span for multispan conditions. Values neglect slab stiffness of fill and are based on a 150 lb/ft of width concentrated load producing L/240 deflection.
3. See Slab Tables for the load capacities.
4. Canam does not recommend the use of weld washers on deck thicker than or equal to 22 gage.
5. SDI recommends 2 1/2" as the minimum cover for insulating concrete decks. This table uses the 2 1/2" cover to establish a lower limit for diaphragm checks.
6. Density is presented as an order of magnitude and does not affect the shear strength for insulating fill; f'_c is critical.
7. Q_t = Nominal Shear Capacity of Support Fastener
 Q_s = Nominal Shear Capacity of Side Lap Fastener

$$G' = \frac{K_2}{K_4 + 3K_1 L_v} + K_3 \text{ (kips/in)}$$

t	.0179	.0239	.0295	.0358
K_2	528	705	870	1056
K_3	260			

Deck	K_4
UFXV	3.64

TABLES



FORM DECK, UF2XV - Insulating Fill Type I, Weld Screw

Deck: $F_y = 80$ ksi
Type I Insulating Concrete

Fastener Pattern = 30/3

Load Type	ASD Ω	LRFD ϕ
All	3.25	0.50
	S_n/Ω	ϕS_n

30 pcf $f'c = 125$ psi with 2 1/2" cover over deck

Fastener Support 16 gage weld washers w/ 3/8" opening (< 22 ga deck) (Q_t)
 5/8" ϕ puddle welds (\geq 22 ga deck) (Q_t)
 Side-Lap # 10 screws (Q_s)

UF2XV Form Deck Slab Diaphragm Tables

Deck "t"	Side-Lap Conn. / Span	Nominal Shear Strength (S_n), PLF											K_1
		Span (L_v), Ft.											
		4.5	5.0	5.5	6.0	6.5	7.0	7.5	8.0	8.5	9.0	9.5	
24 gage	0	1111	1045	991	945	907	874	846	821	799	779	762	0.954
	1	1226	1148	1084	1031	986	948	914	885	859	836	816	0.626
	Q_t (lb)	1340	1251	1178	1117	1065	1021	983	949	920	894	870	0.466
	2198	1454	1353	1271	1202	1144	1094	1051	1014	980	951	924	0.371
	Q_s (lb)	1568	1456	1364	1288	1223	1168	1120	1078	1041	1008	978	0.309
514	1682	1559	1458	1374	1302	1241	1188	1142	1101	1065	1032	0.264	
22 gage	0	1171	1099	1040	990	949	913	882	855	831	809	790	1.059
	1	1312	1226	1155	1096	1046	1003	966	934	905	880	857	0.696
	Q_t (lb)	1453	1353	1270	1202	1144	1094	1051	1013	980	950	924	0.518
	2396	1594	1480	1386	1307	1241	1185	1135	1092	1054	1021	991	0.413
	Q_s (lb)	1735	1606	1501	1413	1339	1275	1220	1172	1129	1091	1057	0.343
634	1876	1733	1616	1519	1436	1366	1305	1251	1204	1162	1124	0.293	
20 gage	0	1317	1230	1159	1099	1049	1006	969	936	908	882	859	1.167
	1	1488	1384	1299	1228	1168	1116	1072	1033	998	968	940	0.766
	Q_t (lb)	1659	1538	1439	1356	1286	1226	1174	1129	1089	1053	1021	0.571
	2877	1830	1692	1578	1484	1404	1336	1277	1225	1179	1139	1102	0.454
	Q_s (lb)	2001	1846	1718	1612	1523	1446	1379	1321	1270	1224	1183	0.378
770	2172	1999	1858	1741	1641	1556	1482	1417	1360	1310	1264	0.323	
18 gage	0	1576	1463	1371	1294	1229	1173	1124	1082	1045	1012	982	1.343
	1	1802	1667	1556	1464	1385	1318	1260	1209	1165	1125	1089	0.882
	Q_t (lb)	2029	1871	1741	1633	1542	1464	1396	1337	1285	1238	1196	0.657
	3734	2255	2074	1926	1803	1699	1610	1532	1464	1404	1351	1304	0.523
	Q_s (lb)	2482	2278	2112	1973	1856	1755	1668	1592	1524	1464	1411	0.434
1019	2708	2482	2297	2143	2012	1901	1804	1719	1644	1578	1518	0.372	

NOTES

1. Shaded Area does not conform to SDI maximum fastener spacing of 36" o.c. for spans greater than 5' 0".
2. Values to the right of the bold line exceed the maximum recommended span for multispan conditions. Values neglect slab stiffness of fill and are based on a 150 lb/ft of width concentrated load producing L/240 deflection.
3. See Slab Tables for the load capacities.
4. Canam does not recommend the use of weld washers on deck thicker than or equal to 22 gage.
5. SDI recommends 2 1/2" as the minimum cover for insulating concrete decks. This table uses the 2 1/2" cover to establish a lower limit for diaphragm checks.
6. Density is presented as an order of magnitude and does not affect the shear strength for insulating fill; f'_c is critical.
7. Q_t = Nominal Shear Capacity of Support Fastener
 Q_s = Nominal Shear Capacity of Side Lap Fastener

$$G' = \frac{K_2}{K_4 + 3K_1 L_v} + K_3 \text{ (kips/in)}$$

t	.0239	.0295	.0358	.0474
K_2	705	870	1056	1398
K_3	260			

Deck	K_4
UF2XV	3.57

TABLES



FORM DECK, UFSV - Insulating Fill Type II, Weld Screw

Deck: $F_y = 80$ ksi Fastener Pattern = 35/4
Type II Insulating Concrete with Embedded Insulation Board

30 pcf $f'c = 125$ psi with 2 1/2" cover over deck

Fastener Support 16 gage weld washers w/ 3/8" opening (< 22 ga deck) (Q_s)
5/8" ϕ puddle welds (≥ 22 ga deck) (Q_f)
Side-Lap # 10 screws (Q_s)

Load Type	ASD Ω	LRFD ϕ
All	3.25	0.50
	S_r/Ω	ϕS_n

UFSV Form Deck Slab Diaphragm Tables

Deck "t"	Side-Lap Conn. / Span	Nominal Shear Strength (S_n), PLF										K_1		
		Span (L_v), Ft.												
		1.5	2.0	2.5	3.0	3.5	4.0	4.5	5.0	5.5	6.0	6.5		
28 gage	0.0149	0	1906	1609	1430	1311	1226	1162	1112	1073	1040	1013	990	0.497
		1	2120	1769	1558	1418	1317	1242	1184	1137	1099	1067	1040	0.354
	Q_f (lb)	2	2333	1929	1686	1524	1409	1322	1255	1201	1157	1120	1089	0.275
	1131	3	2547	2089	1814	1631	1500	1402	1326	1265	1215	1173	1138	0.225
	Q_s (lb)	4	2760	2249	1942	1738	1592	1482	1397	1329	1273	1227	1187	0.190
	320	5	2974	2409	2071	1845	1683	1562	1468	1393	1331	1280	1237	0.165
26 gage	0.0179	0	2247	1864	1634	1481	1372	1290	1226	1175	1133	1098	1069	0.545
		1	2503	2056	1788	1609	1482	1386	1311	1252	1203	1162	1128	0.388
	Q_f (lb)	2	2760	2249	1942	1738	1592	1482	1397	1329	1273	1227	1187	0.302
	1455	3	3016	2441	2096	1866	1702	1578	1482	1406	1343	1291	1246	0.247
	Q_s (lb)	4	3273	2634	2250	1994	1812	1675	1568	1483	1413	1355	1306	0.209
	385	5	3529	2826	2404	2123	1922	1771	1654	1560	1483	1419	1365	0.181
24 gage	0.0239	0	3029	2450	2103	1872	1707	1583	1487	1410	1346	1294	1249	0.629
		1	3371	2707	2309	2043	1854	1711	1601	1512	1440	1379	1328	0.449
	Q_f (lb)	2	3714	2964	2515	2215	2001	1840	1715	1615	1533	1465	1407	0.349
	2198	3	4057	3221	2720	2386	2147	1968	1829	1718	1627	1551	1487	0.285
	Q_s (lb)	4	4399	3478	2926	2557	2294	2097	1943	1821	1720	1636	1566	0.241
	514	5	4742	3735	3131	2729	2441	2225	2058	1923	1814	1722	1645	0.209
22 gage	0.0295	0	3237	2607	2229	1976	1796	1661	1556	1472	1403	1346	1298	0.699
		1	3660	2924	2482	2188	1978	1820	1697	1599	1519	1452	1395	0.499
	Q_f (lb)	2	4083	3241	2736	2399	2159	1978	1838	1726	1634	1557	1493	0.387
	2396	3	4506	3558	2990	2611	2340	2137	1979	1853	1749	1663	1590	0.317
	Q_s (lb)	4	4929	3875	3243	2822	2521	2295	2120	1979	1865	1769	1688	0.268
	634	5	5352	4193	3497	3034	2702	2454	2261	2106	1980	1875	1785	0.232
20 gage	0.0358	0	3744	2987	2532	2230	2013	1851	1725	1624	1541	1473	1414	0.770
		1	4257	3371	2840	2486	2233	2043	1896	1778	1681	1601	1533	0.549
	Q_f (lb)	2	4770	3756	3148	2743	2453	2236	2067	1932	1821	1729	1651	0.427
	2877	3	5283	4141	3456	2999	2673	2428	2238	2086	1961	1857	1770	0.349
	Q_s (lb)	4	5796	4526	3764	3256	2893	2621	2409	2240	2101	1986	1888	0.295
	770	5	6309	4911	4072	3512	3113	2813	2580	2394	2241	2114	2006	0.256

NOTES

1. Shaded Area does not conform to SDI maximum fastener spacing of 36" o.c. for spans greater than 5' 0".
2. Values to the right of the **bold** line exceed the maximum recommended span for multispan conditions. Values neglect slab stiffness of fill and are based on a 150 lb/ft of width concentrated load producing L/240 deflection.
3. See Slab Tables for the load capacities.
4. Canam does not recommend the use of weld washers on deck thicker than or equal to 22 gage.
5. SDI recommends 2 1/2" as the minimum cover for insulating concrete decks. This table uses the 2 1/2" cover to establish a lower limit for diaphragm checks.
6. Density is presented as an order of magnitude and does not affect the shear strength for insulating fill; $f'c$ is critical.
7. Q_f = Nominal Shear Capacity of Support Fastener
 Q_s = Nominal Shear Capacity of Side Lap Fastener

$$G' = \frac{K_2}{K_4 + 3K_1 L_v} + K_3 \text{ (kips/in)}$$

t	.0149	.0179	.0239	.0295	.0358
K_2	440	528	705	870	1056
K_3	260				

Deck	K_4
UFSV	2.83

TABLES



FORM DECK, UF1XV - Insulating Fill Type II, Weld Screw

Deck: $F_y = 80$ ksi Fastener Pattern = 27/3
Type II Insulating Concrete with Embedded Insulation Board

30 pcf $f'_c = 125$ psi with 2 1/2" cover over deck

Fastener Support 16 gage weld washers w/ 3/8" opening (< 22 ga deck) (Q_t)
5/8" ϕ puddle welds (≥ 22 ga deck) (Q_s)
Side-Lap # 10 screws (Q_s)

Load Type	ASD Ω	LRFD ϕ
All	3.25	0.50
	S_u/Ω	ϕS_n

UF1XV Form Deck Slab Diaphragm Tables

Deck "t"	Side-Lap Conn. / Span	Nominal Shear Strength (S_n), PLF											K_1																																																																																																																																																																																																																																												
		Span (L_v), Ft.																																																																																																																																																																																																																																																							
		1.5	2.0	2.5	3.0	3.5	4.0	4.5	5.0	5.5	6.0	6.5																																																																																																																																																																																																																																													
26 gage	0	2009	1685	1491	1362	1270	1200	1147	1103	1068	1039	1014	1.009																																																																																																																																																																																																																																												
	1	2265	1878	1645	1490	1380	1297	1232	1180	1138	1103	1073	0.640																																																																																																																																																																																																																																												
	Q_t (lb)	2522	2070	1799	1619	1490	1393	1318	1257	1208	1167	1132	0.469																																																																																																																																																																																																																																												
	1455	2778	2263	1953	1747	1600	1489	1403	1334	1278	1231	1192	0.370																																																																																																																																																																																																																																												
	Q_s (lb)	3035	2455	2107	1875	1710	1585	1489	1411	1348	1295	1251	0.306																																																																																																																																																																																																																																												
385	3292	2648	2261	2004	1820	1682	1574	1488	1418	1360	1310	0.260	24 gage	0	2669	2181	1888	1692	1553	1448	1367	1302	1248	1204	1166	1.165	1	3012	2438	2093	1864	1700	1577	1481	1404	1342	1290	1245	0.740	Q_t (lb)	3354	2695	2299	2035	1846	1705	1595	1507	1435	1375	1325	0.542	2198	3697	2952	2504	2206	1993	1834	1709	1610	1529	1461	1404	0.428	Q_s (lb)	4040	3209	2710	2378	2140	1962	1824	1713	1622	1547	1483	0.353	514	4382	3465	2916	2549	2287	2091	1938	1816	1716	1632	1562	0.301	22 gage	0	2845	2313	1994	1781	1628	1514	1426	1355	1296	1248	1207	1.295	1	3268	2630	2247	1992	1810	1673	1566	1481	1412	1354	1305	0.822	Q_t (lb)	3691	2947	2501	2203	1991	1831	1707	1608	1527	1459	1402	0.602	2396	4114	3264	2755	2415	2172	1990	1848	1735	1642	1565	1500	0.475	Q_s (lb)	4537	3581	3008	2626	2353	2149	1989	1862	1758	1671	1597	0.392	634	4960	3899	3262	2838	2534	2307	2130	1989	1873	1777	1695	0.334	20 gage	0	3273	2634	2250	1994	1812	1675	1568	1483	1413	1355	1306	1.426	1	3786	3018	2558	2251	2032	1867	1739	1637	1553	1483	1424	0.906	Q_t (lb)	4299	3403	2866	2507	2251	2059	1910	1791	1693	1611	1543	0.663	2877	4812	3788	3174	2764	2471	2252	2081	1945	1833	1740	1661	0.523	Q_s (lb)	5326	4173	3482	3021	2691	2444	2252	2099	1973	1868	1779	0.432	770	5839	4558	3789	3277	2911	2637	2423	2252	2113	1996	1898	0.368
24 gage	0	2669	2181	1888	1692	1553	1448	1367	1302	1248	1204	1166		1.165																																																																																																																																																																																																																																											
	1	3012	2438	2093	1864	1700	1577	1481	1404	1342	1290	1245		0.740																																																																																																																																																																																																																																											
	Q_t (lb)	3354	2695	2299	2035	1846	1705	1595	1507	1435	1375	1325		0.542																																																																																																																																																																																																																																											
	2198	3697	2952	2504	2206	1993	1834	1709	1610	1529	1461	1404		0.428																																																																																																																																																																																																																																											
	Q_s (lb)	4040	3209	2710	2378	2140	1962	1824	1713	1622	1547	1483	0.353																																																																																																																																																																																																																																												
514	4382	3465	2916	2549	2287	2091	1938	1816	1716	1632	1562	0.301	22 gage	0	2845	2313	1994	1781	1628	1514	1426	1355	1296	1248	1207	1.295	1	3268	2630	2247	1992	1810	1673	1566	1481	1412	1354	1305	0.822	Q_t (lb)	3691	2947	2501	2203	1991	1831	1707	1608	1527	1459	1402	0.602	2396	4114	3264	2755	2415	2172	1990	1848	1735	1642	1565	1500	0.475	Q_s (lb)	4537	3581	3008	2626	2353	2149	1989	1862	1758	1671	1597	0.392	634	4960	3899	3262	2838	2534	2307	2130	1989	1873	1777	1695	0.334	20 gage	0	3273	2634	2250	1994	1812	1675	1568	1483	1413	1355	1306	1.426	1	3786	3018	2558	2251	2032	1867	1739	1637	1553	1483	1424	0.906	Q_t (lb)	4299	3403	2866	2507	2251	2059	1910	1791	1693	1611	1543	0.663	2877	4812	3788	3174	2764	2471	2252	2081	1945	1833	1740	1661	0.523	Q_s (lb)	5326	4173	3482	3021	2691	2444	2252	2099	1973	1868	1779	0.432	770	5839	4558	3789	3277	2911	2637	2423	2252	2113	1996	1898	0.368																																																																															
22 gage	0	2845	2313	1994	1781	1628	1514	1426	1355	1296	1248	1207		1.295																																																																																																																																																																																																																																											
	1	3268	2630	2247	1992	1810	1673	1566	1481	1412	1354	1305		0.822																																																																																																																																																																																																																																											
	Q_t (lb)	3691	2947	2501	2203	1991	1831	1707	1608	1527	1459	1402		0.602																																																																																																																																																																																																																																											
	2396	4114	3264	2755	2415	2172	1990	1848	1735	1642	1565	1500		0.475																																																																																																																																																																																																																																											
	Q_s (lb)	4537	3581	3008	2626	2353	2149	1989	1862	1758	1671	1597	0.392																																																																																																																																																																																																																																												
634	4960	3899	3262	2838	2534	2307	2130	1989	1873	1777	1695	0.334	20 gage	0	3273	2634	2250	1994	1812	1675	1568	1483	1413	1355	1306	1.426	1	3786	3018	2558	2251	2032	1867	1739	1637	1553	1483	1424	0.906	Q_t (lb)	4299	3403	2866	2507	2251	2059	1910	1791	1693	1611	1543	0.663	2877	4812	3788	3174	2764	2471	2252	2081	1945	1833	1740	1661	0.523	Q_s (lb)	5326	4173	3482	3021	2691	2444	2252	2099	1973	1868	1779	0.432	770	5839	4558	3789	3277	2911	2637	2423	2252	2113	1996	1898	0.368																																																																																																																																																														
20 gage	0	3273	2634	2250	1994	1812	1675	1568	1483	1413	1355	1306		1.426																																																																																																																																																																																																																																											
	1	3786	3018	2558	2251	2032	1867	1739	1637	1553	1483	1424		0.906																																																																																																																																																																																																																																											
	Q_t (lb)	4299	3403	2866	2507	2251	2059	1910	1791	1693	1611	1543		0.663																																																																																																																																																																																																																																											
	2877	4812	3788	3174	2764	2471	2252	2081	1945	1833	1740	1661		0.523																																																																																																																																																																																																																																											
	Q_s (lb)	5326	4173	3482	3021	2691	2444	2252	2099	1973	1868	1779	0.432																																																																																																																																																																																																																																												
770	5839	4558	3789	3277	2911	2637	2423	2252	2113	1996	1898	0.368																																																																																																																																																																																																																																													

NOTES

1. Shaded Area does not conform to SDI maximum fastener spacing of 36" o.c. for spans greater than 5' 0".
2. Values to the right of the bold line exceed the maximum recommended span for multispan conditions. Values neglect slab stiffness of fill and are based on a 150 lb/ft of width concentrated load producing L/240 deflection.
3. See Slab Tables for the load capacities.
4. Canam does not recommend the use of weld washers on deck thicker than or equal to 22 gage.
5. SDI recommends 2 1/2" as the minimum cover for insulating concrete decks. This table uses the 2 1/2" cover to establish a lower limit for diaphragm checks.
6. Density is presented as an order of magnitude and does not affect the shear strength for insulating fill; f'_c is critical.
7. Q_t = Nominal Shear Capacity of Support Fastener
 Q_s = Nominal Shear Capacity of Side Lap Fastener

$$G' = \frac{K_2}{K_4 + 3K_1 L_v} + K_3 \text{ (kips/in)}$$

t	.0179	.0239	.0295	.0358
K_2	528	705	870	1056
K_3	260			

Deck	K_4
UF1XV	3.15

TABLES



FORM DECK, UFXV - Insulating Fill Type II, Weld Screw

Deck: $F_y = 80$ ksi Fastener Pattern = 36/4
Type II Insulating Concrete with Embedded Insulation Board

Load Type	ASD Ω	LRFD ϕ
All	3.25	0.50
	S_u/Ω	ϕS_n

30 pcf $f'_c = 125$ psi with 2 1/2" cover over deck

Fastener Support 16 gage weld washers w/ 3/8" opening (< 22 ga deck) (Q_t)
5/8" ϕ puddle welds (≥ 22 ga deck) (Q_t)
Side-Lap # 10 screws (Q_s)

UFXV Form Deck Slab Diaphragm Tables

Deck "t"	Side-Lap Conn. / Span	Nominal Shear Strength (S_n), PLF											K_1	
		Span (L_v), Ft.												
		3.5	4.0	4.5	5.0	5.5	6.0	6.5	7.0	7.5	8.0	8.5		
26 gage	0	1372	1290	1226	1175	1133	1098	1069	1044	1022	1003	986	0.530	
	1	1482	1386	1311	1252	1203	1162	1128	1099	1073	1051	1031	0.378	
	Q_t (lb)	2	1592	1482	1397	1329	1273	1227	1187	1154	1124	1099	1076	0.293
	1455	3	1702	1578	1482	1406	1343	1291	1246	1209	1176	1147	1122	0.240
	Q_s (lb)	4	1812	1675	1568	1483	1413	1355	1306	1264	1227	1195	1167	0.203
385	5	1922	1771	1654	1560	1483	1419	1365	1319	1278	1243	1212	0.176	
24 gage	0	1707	1583	1487	1410	1346	1294	1249	1211	1178	1149	1124	0.612	
	1	1854	1711	1601	1512	1440	1379	1328	1285	1247	1214	1184	0.436	
	Q_t (lb)	2	2001	1840	1715	1615	1533	1465	1407	1358	1315	1278	1245	0.339
	2198	3	2147	1968	1829	1718	1627	1551	1487	1431	1384	1342	1305	0.277
	Q_s (lb)	4	2294	2097	1943	1821	1720	1636	1566	1505	1452	1406	1366	0.234
514	5	2441	2225	2058	1923	1814	1722	1645	1578	1521	1470	1426	0.203	
22 gage	0	1796	1661	1556	1472	1403	1346	1298	1256	1220	1188	1161	0.680	
	1	1978	1820	1697	1599	1519	1452	1395	1347	1304	1268	1235	0.485	
	Q_t (lb)	2	2159	1978	1838	1726	1634	1557	1493	1437	1389	1347	1310	0.377
	2396	3	2340	2137	1979	1853	1749	1663	1590	1528	1474	1426	1384	0.308
	Q_s (lb)	4	2521	2295	2120	1979	1865	1769	1688	1618	1558	1506	1459	0.260
634	5	2702	2454	2261	2106	1980	1875	1785	1709	1643	1585	1534	0.226	
20 gage	0	2013	1851	1725	1624	1541	1473	1414	1364	1321	1283	1250	0.749	
	1	2233	2043	1896	1778	1681	1601	1533	1474	1424	1380	1340	0.534	
	Q_t (lb)	2	2453	2236	2067	1932	1821	1729	1651	1584	1526	1476	1431	0.415
	2877	3	2673	2428	2238	2086	1961	1857	1770	1694	1629	1572	1522	0.339
	Q_s (lb)	4	2893	2621	2409	2240	2101	1986	1888	1804	1732	1668	1612	0.287
770	5	3113	2813	2580	2394	2241	2114	2006	1914	1834	1764	1703	0.249	

NOTES

1. Shaded Area does not conform to SDI maximum fastener spacing of 36" o.c. for spans greater than 5' 0".
2. Values to the right of the bold line exceed the maximum recommended span for multispan conditions. Values neglect slab stiffness of fill and are based on a 150 lb/ft of width concentrated load producing L/240 deflection.
3. See Slab Tables for the load capacities.
4. Canam does not recommend the use of weld washers on deck thicker than or equal to 22 gage.
5. SDI recommends 2 1/2" as the minimum cover for insulating concrete decks. This table uses the 2 1/2" cover to establish a lower limit for diaphragm checks.
6. Density is presented as an order of magnitude and does not affect the shear strength for insulating fill; f'_c is critical.
7. Q_t = Nominal Shear Capacity of Support Fastener
 Q_s = Nominal Shear Capacity of Side Lap Fastener

$$G' = \frac{K_2}{K_2 + 3K_1 L_v} + K_3 \text{ (kips/in)}$$

t	.0179	.0239	.0295	.0358
K_2	528	705	870	1056
K_3	260			

Deck	K_4
UFXV	3.64

TABLES



FORM DECK, UF2XV - Insulating Fill Type II, Weld Screw

Deck: $F_y = 80$ ksi Fastener Pattern = 30/3
Type II Insulating Concrete with Embedded Insulation Board

30 pcf $f'_c = 125$ psi with 2 1/2" cover over deck

Load Type	ASD Ω	LRFD ϕ
All	3.25	0.50
	S_n/Ω	ϕS_n

Fastener Support 16 gage weld washers w/ 3/8" opening (< 22 ga deck) (Q_t)
5/8" ϕ puddle welds (\geq 22 ga deck) (Q_t)
Side-Lap # 10 screws (Q_s)

UF2XV Form Deck Slab Diaphragm Tables

Deck "t"	Side-Lap Conn. / Span	Nominal Shear Strength (S_n), PLF											K_1
		Span (L_v), Ft.											
		4.5	5.0	5.5	6.0	6.5	7.0	7.5	8.0	8.5	9.0	9.5	
24 gage	0	1380	1313	1259	1214	1175	1143	1114	1089	1067	1048	1030	0.954
	1	1494	1416	1352	1299	1254	1216	1183	1153	1128	1105	1084	0.626
	Q_t (lb)	1608	1519	1446	1385	1334	1289	1251	1218	1188	1162	1138	0.466
	2198	1722	1622	1539	1471	1413	1363	1320	1282	1249	1219	1192	0.371
	Q_s (lb)	1837	1724	1633	1556	1492	1436	1388	1346	1309	1276	1247	0.309
514	1951	1827	1726	1642	1571	1510	1457	1410	1369	1333	1301	0.264	
22 gage	0	1440	1367	1308	1259	1217	1181	1150	1123	1099	1078	1059	1.059
	1	1581	1494	1423	1364	1314	1272	1235	1202	1174	1148	1125	0.696
	Q_t (lb)	1722	1621	1539	1470	1412	1362	1319	1281	1248	1219	1192	0.518
	2396	1863	1748	1654	1576	1510	1453	1404	1361	1323	1289	1259	0.413
	Q_s (lb)	2003	1875	1769	1682	1607	1544	1488	1440	1397	1360	1326	0.343
634	2144	2002	1885	1787	1705	1634	1573	1519	1472	1430	1392	0.293	
20 gage	0	1585	1498	1427	1368	1318	1275	1237	1205	1176	1150	1127	1.167
	1	1756	1652	1567	1496	1436	1384	1340	1301	1266	1236	1208	0.766
	Q_t (lb)	1927	1806	1707	1624	1554	1494	1443	1397	1357	1321	1289	0.571
	2877	2098	1960	1847	1753	1673	1604	1545	1493	1448	1407	1370	0.454
	Q_s (lb)	2269	2114	1987	1881	1791	1714	1648	1590	1538	1492	1452	0.378
770	2440	2268	2127	2009	1910	1824	1750	1686	1629	1578	1533	0.323	
18 gage	0	1844	1731	1639	1562	1497	1441	1393	1350	1313	1280	1250	1.343
	1	2071	1935	1824	1732	1654	1587	1529	1478	1433	1393	1357	0.882
	Q_t (lb)	2297	2139	2010	1902	1810	1732	1664	1605	1553	1506	1465	0.657
	3734	2524	2343	2195	2072	1967	1878	1800	1733	1673	1620	1572	0.523
	Q_s (lb)	2750	2547	2380	2241	2124	2023	1936	1860	1793	1733	1679	0.434
1019	2976	2750	2565	2411	2281	2169	2072	1987	1913	1846	1787	0.372	

NOTES

1. Shaded Area does not conform to SDI maximum fastener spacing of 36" o.c. for spans greater than 5' 0".
2. Values to the right of the bold line exceed the maximum recommended span for multispan conditions. Values neglect slab stiffness of fill and are based on a 150 lb/ft of width concentrated load producing L/240 deflection.
3. See Slab Tables for the load capacities.
4. Canam does not recommend the use of weld washers on deck thicker than or equal to 22 gage.
5. SDI recommends 2 1/2" as the minimum cover for insulating concrete decks. This table uses the 2 1/2" cover to establish a lower limit for diaphragm checks.
6. Density is presented as an order of magnitude and does not affect the shear strength for insulating fill; f'_c is critical.
7. Q_t = Nominal Shear Capacity of Support Fastener
 Q_s = Nominal Shear Capacity of Side Lap Fastener

$$G' = \frac{K_2}{K_4 + 3K_1 L_v} + K_3 \text{ (kips/in)}$$

t	.0239	.0295	.0358	.0474
K_2	705	870	1056	1398
K_3	260			

Deck	K_4
UF2XV	3.57

TABLES



FORM DECK, UFSV - Insulating Fill Type I, Screw Screw

Deck: $F_y = 80$ ksi
Type I Insulating Concrete

Fastener Pattern = 35/4

30 pcf $f'c = 125$ psi with 2 1/2" cover over deck

Fastener Support # 12 screws (Q_t)
Side-Lap # 10 screws (Q_s)

Load Type	ASD Ω	LRFD ϕ
All	3.25	0.50
	S_e/Ω	ϕS_n

UFSV Form Deck Slab Diaphragm Tables

Deck "t"	Side-Lap Conn. / Span	Nominal Shear Strength (S_n), PLF											K_1	
		Span (L_v), Ft.												
		1.5	2.0	2.5	3.0	3.5	4.0	4.5	5.0	5.5	6.0	6.5		
28 gage	0	1270	1065	941	859	800	756	722	694	672	653	637	0.562	
	1	1484	1225	1069	966	892	836	793	758	730	706	686	0.386	
	Q_t (lb)	2	1698	1385	1197	1072	983	916	864	822	788	760	736	0.294
	782	3	1911	1545	1326	1179	1075	996	935	886	846	813	785	0.238
	Q_s (lb)	4	2125	1705	1454	1286	1166	1076	1006	950	905	867	834	0.199
320	5	2338	1866	1582	1393	1258	1156	1078	1015	963	920	884	0.172	
26 gage	0	1436	1189	1041	942	871	818	777	744	717	694	675	0.616	
	1	1693	1381	1195	1070	981	914	862	821	787	759	735	0.423	
	Q_t (lb)	2	1949	1574	1349	1198	1091	1011	948	898	857	823	794	0.322
	940	3	2206	1766	1502	1327	1201	1107	1033	975	927	887	853	0.260
	Q_s (lb)	4	2463	1959	1656	1455	1311	1203	1119	1052	997	951	912	0.218
385	5	2719	2151	1810	1583	1421	1299	1205	1129	1067	1015	971	0.188	
24 gage	0	1768	1438	1240	1107	1013	942	887	843	807	777	752	0.711	
	1	2110	1695	1445	1279	1160	1071	1002	946	901	863	831	0.489	
	Q_t (lb)	2	2453	1951	1651	1450	1307	1199	1116	1049	994	949	910	0.372
	1255	3	2795	2208	1856	1621	1454	1328	1230	1152	1088	1034	989	0.301
	Q_s (lb)	4	3138	2465	2062	1793	1600	1456	1344	1254	1181	1120	1068	0.252
514	5	3481	2722	2267	1964	1747	1585	1458	1357	1275	1206	1147	0.217	
22 gage	0	2077	1670	1425	1262	1146	1058	991	936	892	855	823	0.790	
	1	2500	1987	1679	1474	1327	1217	1131	1063	1007	960	921	0.543	
	Q_t (lb)	2	2923	2304	1933	1685	1508	1376	1272	1190	1122	1066	1019	0.414
	1549	3	3346	2621	2186	1896	1689	1534	1413	1317	1238	1172	1116	0.334
	Q_s (lb)	4	3769	2938	2440	2108	1871	1693	1554	1444	1353	1278	1214	0.280
634	5	4191	3255	2694	2319	2052	1851	1695	1570	1468	1383	1311	0.241	
20 gage	0	2425	1931	1634	1436	1295	1189	1107	1041	987	942	904	0.871	
	1	2938	2316	1942	1693	1515	1381	1278	1195	1127	1070	1022	0.598	
	Q_t (lb)	2	3452	2700	2250	1949	1735	1574	1449	1349	1267	1198	1141	0.456
	1880	3	3965	3085	2558	2206	1955	1766	1620	1502	1407	1327	1259	0.368
	Q_s (lb)	4	4478	3470	2866	2463	2175	1959	1791	1656	1546	1455	1377	0.309
770	5	4991	3855	3173	2719	2395	2151	1962	1810	1686	1583	1496	0.266	

- NOTES**
1. Shaded Area does not conform to SDI maximum fastener spacing of 36" o.c. for spans greater than 5' 0".
 2. Values to the right of the **bold** line exceed the maximum recommended span for multispan conditions. Values neglect slab stiffness of fill and are based on a 150 lb/ft of width concentrated load producing L/240 deflection.
 3. See Slab Tables for the load capacities.
 4. SDI recommends 2 1/2" as the minimum cover for insulating concrete decks. This table uses the 2 1/2" cover to establish a lower limit for diaphragm checks.
 5. Density is presented as an order of magnitude and does not affect the shear strength for insulating fill; f'_c is critical.
 6. Q_t = Nominal Shear Capacity of Support Fastener
 Q_s = Nominal Shear Capacity of Side Lap Fastener

$$G' = \frac{K_2}{K_4 + 3K_1 L_v} + K_3 \text{ (kips/in)}$$

t	.0149	.0179	.0239	.0295	.0358
K_2	440	528	705	870	1056
K_3	260				

Deck	K_4
UFSV	2.83

TABLES



FORM DECK, UF1XV - Insulating Fill Type I, Screw Screw

Deck: $F_y = 80$ ksi
Type I Insulating Concrete

Fastener Pattern = 27/3

30 pcf $f'c = 125$ psi with 2 1/2" cover over deck

Fastener Support #12 Screw (Q_s)
Side-Lap # 10 screws (Q_s)

Load Type	ASD Ω	LRFD ϕ
All	3.25	0.50
	S_p/Ω	ϕS_n

UF1XV Form Deck Slab Diaphragm Tables

Deck "t"	Side-Lap Conn. / Span	Nominal Shear Strength (S_n), PLF											K_1	
		Span (L_v), Ft.												
		1.5	2.0	2.5	3.0	3.5	4.0	4.5	5.0	5.5	6.0	6.5		
26 gage	0.0179	0	1283	1074	948	865	805	760	726	698	675	656	640	1.140
		1	1539	1266	1102	993	915	857	811	775	745	720	699	0.691
	Q_s (lb)	2	1796	1459	1256	1121	1025	953	897	852	815	784	758	0.496
	940	3	2052	1651	1410	1250	1135	1049	982	929	885	848	818	0.387
	Q_s (lb)	4	2309	1843	1564	1378	1245	1145	1068	1006	955	913	877	0.317
	385	5	2565	2036	1718	1506	1355	1242	1153	1083	1025	977	936	0.268
24 gage	0.0239	0	1563	1284	1116	1005	925	865	819	782	751	726	705	1.318
		1	1905	1541	1322	1176	1072	994	933	885	845	812	784	0.798
	Q_s (lb)	2	2248	1798	1527	1347	1219	1122	1047	987	938	897	863	0.573
	1255	3	2590	2054	1733	1519	1366	1251	1162	1090	1032	983	942	0.447
	Q_s (lb)	4	2933	2311	1939	1690	1512	1379	1276	1193	1125	1069	1021	0.366
	514	5	3275	2568	2144	1861	1659	1508	1390	1296	1219	1154	1100	0.310
22 gage	0.0295	0	1824	1480	1273	1136	1037	963	906	860	823	791	765	1.464
		1	2247	1797	1527	1347	1218	1122	1047	987	938	897	862	0.887
	Q_s (lb)	2	2670	2114	1781	1558	1400	1281	1188	1114	1053	1003	960	0.636
	1549	3	3092	2431	2034	1770	1581	1439	1329	1241	1169	1109	1058	0.496
	Q_s (lb)	4	3515	2748	2288	1981	1762	1598	1470	1368	1284	1214	1155	0.407
	634	5	3938	3065	2542	2193	1943	1756	1611	1494	1399	1320	1253	0.344
20 gage	0.0358	0	2118	1700	1450	1283	1163	1074	1004	948	903	865	833	1.612
		1	2631	2085	1757	1539	1383	1266	1175	1102	1043	993	951	0.977
	Q_s (lb)	2	3144	2470	2065	1796	1603	1459	1346	1256	1183	1121	1070	0.701
	1880	3	3657	2855	2373	2052	1823	1651	1517	1410	1323	1250	1188	0.547
	Q_s (lb)	4	4170	3240	2681	2309	2043	1843	1688	1564	1463	1378	1306	0.448
	770	5	4684	3624	2989	2565	2263	2036	1859	1718	1603	1506	1425	0.379

- NOTES**
1. Shaded Area does not conform to SDI maximum fastener spacing of 36" o.c. for spans greater than 5' 0".
 2. Values to the right of the bold line exceed the maximum recommended span for multispans conditions. Values neglect slab stiffness of fill and are based on a 150 lb/ft of width concentrated load producing L/240 deflection.
 3. See Slab Tables for the load capacities.
 4. SDI recommends 2 1/2" as the minimum cover for insulating concrete decks. This table uses the 2 1/2" cover to establish a lower limit for diaphragm checks.
 5. Density is presented as an order of magnitude and does not affect the shear strength for insulating fill; f'_c is critical.
 6. Q_s = Nominal Shear Capacity of Support Fastener
 Q_s = Nominal Shear Capacity of Side Lap Fastener

$$G' = \frac{K_2}{K_4 + 3K_1 L_v} + K_3 \text{ (kips/in)}$$

t	.0179	.0239	.0295	.0358
K_2	528	705	870	1056
K_3	260			

Deck	K_4
UF1XV	3.15

TABLES



FORM DECK, UFXV - Insulating Fill Type I, Screw Screw

Deck: $F_y = 80$ ksi Fastener Pattern = 36/4
Type I Insulating Concrete

30 pcf $f_c = 125$ psi with 2 1/2" cover over deck

Fastener Support #12 screws (Q_r)
Side-Lap # 10 screws (Q_s)

Load Type	ASD Ω	LRFD ϕ
All	3.25	0.50
	S_n/Ω	ϕS_n

UFXV Form Deck Slab Diaphragm Tables

Deck "t"	Side-Lap Conn. / Span	Nominal Shear Strength (S_n), PLF											K_1	
		Span (L_v), Ft.												
		3.5	4.0	4.5	5.0	5.5	6.0	6.5	7.0	7.5	8.0	8.5		
26 gage	0	871	818	777	744	717	694	675	659	645	633	622	0.599	
	1	981	914	862	821	787	759	735	714	696	681	667	0.411	
	Q_r (lb)	2	1091	1011	948	898	857	823	794	769	748	729	712	0.313
	940	3	1201	1107	1033	975	927	887	853	824	799	777	758	0.253
	Q_s (lb)	4	1311	1203	1119	1052	997	951	912	879	850	825	803	0.212
385	5	1421	1299	1205	1129	1067	1015	971	934	902	873	848	0.183	
24 gage	0	1013	942	887	843	807	777	752	730	711	695	680	0.692	
	1	1160	1071	1002	946	901	863	831	804	780	759	741	0.475	
	Q_r (lb)	2	1307	1199	1116	1049	994	949	910	877	848	823	801	0.362
	1255	3	1454	1328	1230	1152	1088	1034	989	950	917	888	862	0.292
	Q_s (lb)	4	1600	1456	1344	1254	1181	1120	1068	1024	985	952	922	0.245
514	5	1747	1585	1458	1357	1275	1206	1147	1097	1054	1016	983	0.211	
22 gage	0	1146	1058	991	936	892	855	823	796	773	753	735	0.769	
	1	1327	1217	1131	1063	1007	960	921	887	858	832	809	0.528	
	Q_r (lb)	2	1508	1376	1272	1190	1122	1066	1019	978	942	911	884	0.402
	1549	3	1689	1534	1413	1317	1238	1172	1116	1068	1027	991	959	0.325
	Q_s (lb)	4	1871	1693	1554	1444	1353	1278	1214	1159	1111	1070	1033	0.273
634	5	2052	1851	1695	1570	1468	1383	1311	1250	1196	1149	1108	0.235	
20 gage	0	1295	1189	1107	1041	987	942	904	871	843	818	796	0.847	
	1	1515	1381	1278	1195	1127	1070	1022	981	945	914	887	0.582	
	Q_r (lb)	2	1735	1574	1449	1349	1267	1198	1141	1091	1048	1011	977	0.443
	1880	3	1955	1766	1620	1502	1407	1327	1259	1201	1151	1107	1068	0.358
	Q_s (lb)	4	2175	1959	1791	1656	1546	1455	1377	1311	1253	1203	1158	0.300
770	5	2395	2151	1962	1810	1686	1583	1496	1421	1356	1299	1249	0.259	

- NOTES**
1. Shaded Area does not conform to SDI maximum fastener spacing of 36" o.c. for spans greater than 5' 0".
 2. Values to the right of the bold line exceed the maximum recommended span for multispans conditions. Values neglect slab stiffness of fill and are based on a 150 lb/ft of width concentrated load producing L/240 deflection.
 3. See Slab Tables for the load capacities.
 4. SDI recommends 2 1/2" as the minimum cover for insulating concrete decks. This table uses the 2 1/2" cover to establish a lower limit for diaphragm checks.
 5. Density is presented as an order of magnitude and does not affect the shear strength for insulating fill; f_c is critical.
 6. Q_r = Nominal Shear Capacity of Support Fastener
 Q_s = Nominal Shear Capacity of Side Lap Fastener

$$G' = \frac{K_2}{K_4 + 3K_1 L_v} + K_3 \text{ (kips/in)}$$

t	.0179	.0239	.0295	.0358
K_2	528	705	870	1056
K_3	260			

Deck	K_4
UFXV	3.64

TABLES



FORM DECK, UF2XV - Insulating Fill Type I, Screw Screw

Deck: $F_y = 80$ ksi
Type I Insulating Concrete

Fastener Pattern = 30/3

30 pcf $f'_c = 125$ psi with 2 1/2" cover over deck

Fastener Support #12 screws (Q_t)
Side-Lap # 10 screws (Q_s)

Load Type	ASD Ω	LRFD ϕ
All	3.25	0.50
	S_n/Ω	ϕS_n

UF2XV Form Deck Slab Diaphragm Tables

Deck "t"	Side-Lap Conn. / Span	Nominal Shear Strength (S_n), PLF											K_1	
		Span (L_v), Ft.												
		4.5	5.0	5.5	6.0	6.5	7.0	7.5	8.0	8.5	9.0	9.5		
24 gage	0	826	789	757	732	710	691	675	661	648	637	627	1.078	
	1	941	891	851	817	789	764	743	725	708	694	681	0.678	
	Q_t (lb)	2	1055	994	944	903	868	838	812	789	769	751	735	0.494
	1255	3	1169	1097	1038	989	947	911	880	853	829	808	789	0.389
	Q_s (lb)	4	1283	1200	1131	1074	1026	985	949	917	890	865	843	0.320
514	5	1397	1302	1225	1160	1105	1058	1017	982	950	922	897	0.273	
22 gage	0	915	868	830	798	771	748	728	711	695	681	669	1.198	
	1	1056	995	945	904	869	839	813	790	770	752	736	0.753	
	Q_t (lb)	2	1197	1122	1061	1010	966	929	897	869	844	822	802	0.549
	1549	3	1338	1249	1176	1115	1064	1020	982	948	919	893	869	0.432
	Q_s (lb)	4	1479	1376	1291	1221	1162	1111	1066	1028	993	963	936	0.356
634	5	1620	1503	1407	1327	1259	1201	1151	1107	1068	1034	1003	0.303	
20 gage	0	1015	958	912	873	840	812	788	767	748	731	716	1.319	
	1	1186	1112	1052	1002	959	922	891	863	838	817	797	0.829	
	Q_t (lb)	2	1357	1266	1192	1130	1077	1032	993	959	929	902	878	0.605
	1880	3	1528	1420	1332	1258	1196	1142	1096	1055	1020	988	959	0.476
	Q_s (lb)	4	1699	1574	1472	1386	1314	1252	1199	1152	1110	1073	1040	0.392
770	5	1870	1728	1612	1515	1433	1362	1301	1248	1201	1159	1121	0.334	
18 gage	0	1199	1124	1063	1011	968	931	898	870	845	823	803	1.518	
	1	1426	1328	1248	1181	1125	1076	1034	998	965	936	911	0.954	
	Q_t (lb)	2	1652	1532	1433	1351	1281	1222	1170	1125	1085	1050	1018	0.696
	2489	3	1879	1736	1618	1521	1438	1367	1306	1252	1205	1163	1125	0.548
	Q_s (lb)	4	2105	1939	1804	1691	1595	1513	1442	1380	1325	1276	1233	0.451
1019	5	2332	2143	1989	1861	1752	1659	1578	1507	1445	1389	1340	0.384	

NOTES

1. Shaded Area does not conform to SDI maximum fastener spacing of 36" o.c. for spans greater than 5' 0".
2. Values to the right of the bold line exceed the maximum recommended span for multispans conditions. Values neglect slab stiffness of fill and are based on a 150 lb/ft of width concentrated load producing L/240 deflection.
3. See Slab Tables for the load capacities.
4. SDI recommends 2 1/2" as the minimum cover for insulating concrete decks. This table uses the 2 1/2" cover to establish a lower limit for diaphragm checks.
5. Density is presented as an order of magnitude and does not affect the shear strength for insulating fill; f'_c is critical.
6. Q_t = Nominal Shear Capacity of Support Fastener
 Q_s = Nominal Shear Capacity of Side Lap Fastener

$$G' = \frac{K_2}{K_4 + 3K_1L_v} + K_3 \text{ (kips/in)}$$

t	.0239	.0295	.0358	.0474
K_2	705	870	1056	1398
K_3	260			

Deck	K_4
UF2XV	3.57

DIAPHRAGM

TABLES



FORM DECK, UFSV - Insulating Fill Type II, Screw Screw

Deck: $F_y = 80$ ksi Fastener Pattern = 35/4
Type II Insulating Concrete with Embedded Insulation Board

30 pcf $f'c = 125$ psi with 2 1/2" cover over deck

Fastener Support # 12 screws (Q_t)
Side-Lap # 10 screws (Q_s)

Load Type	ASD Ω	LRFD ϕ
All	3.25	0.50
	S_e/Ω	ϕS_n

UFSV Form Deck Slab Diaphragm Tables

Deck "t"	Side-Lap Conn. / Span	Nominal Shear Strength (S_n), PLF											K_1	
		Span (L_v), Ft.												
		1.5	2.0	2.5	3.0	3.5	4.0	4.5	5.0	5.5	6.0	6.5		
28 gage	0	1539	1333	1210	1127	1068	1024	990	963	940	921	906	0.562	
	1	1752	1493	1338	1234	1160	1104	1061	1027	998	975	955	0.386	
	Q_t (lb)	2	1966	1653	1466	1341	1251	1184	1132	1091	1057	1028	1004	0.294
	782	3	2180	1814	1594	1448	1343	1265	1204	1155	1115	1082	1053	0.238
	Q_s (lb)	4	2393	1974	1722	1554	1434	1345	1275	1219	1173	1135	1103	0.199
320	5	2607	2134	1850	1661	1526	1425	1346	1283	1231	1188	1152	0.172	
26 gage	0	1705	1457	1309	1210	1139	1086	1045	1012	985	963	944	0.616	
	1	1961	1650	1463	1338	1249	1183	1131	1089	1055	1027	1003	0.423	
	Q_t (lb)	2	2218	1842	1617	1467	1359	1279	1216	1166	1125	1091	1062	0.322
	940	3	2474	2035	1771	1595	1469	1375	1302	1243	1195	1155	1121	0.260
	Q_s (lb)	4	2731	2227	1925	1723	1579	1471	1387	1320	1265	1219	1181	0.218
385	5	2987	2419	2079	1851	1689	1567	1473	1397	1335	1284	1240	0.188	
24 gage	0	2036	1706	1508	1376	1281	1211	1156	1112	1076	1046	1020	0.711	
	1	2379	1963	1713	1547	1428	1339	1270	1214	1169	1131	1099	0.489	
	Q_t (lb)	2	2721	2220	1919	1718	1575	1468	1384	1317	1263	1217	1178	0.372
	1255	3	3064	2477	2124	1890	1722	1596	1498	1420	1356	1303	1257	0.301
	Q_s (lb)	4	3406	2734	2330	2061	1869	1725	1612	1523	1449	1388	1337	0.252
514	5	3749	2991	2536	2232	2016	1853	1727	1626	1543	1474	1416	0.217	
22 gage	0	2346	1938	1694	1531	1414	1327	1259	1205	1160	1123	1092	0.790	
	1	2768	2255	1947	1742	1595	1485	1400	1331	1275	1229	1189	0.543	
	Q_t (lb)	2	3191	2572	2201	1953	1777	1644	1541	1458	1391	1334	1287	0.414
	1549	3	3614	2889	2455	2165	1958	1802	1682	1585	1506	1440	1384	0.334
	Q_s (lb)	4	4037	3207	2708	2376	2139	1961	1823	1712	1621	1546	1482	0.280
634	5	4460	3524	2962	2588	2320	2120	1964	1839	1737	1652	1580	0.241	
20 gage	0	2694	2199	1902	1705	1563	1457	1375	1309	1255	1210	1172	0.871	
	1	3207	2584	2210	1961	1783	1650	1546	1463	1395	1338	1290	0.598	
	Q_t (lb)	2	3720	2969	2518	2218	2003	1842	1717	1617	1535	1467	1409	0.456
	1880	3	4233	3354	2826	2474	2223	2035	1888	1771	1675	1595	1527	0.368
	Q_s (lb)	4	4746	3738	3134	2731	2443	2227	2059	1925	1815	1723	1646	0.309
770	5	5259	4123	3442	2987	2663	2419	2230	2079	1955	1851	1764	0.266	

- NOTES
1. Shaded Area does not conform to SDI maximum fastener spacing of 36" o.c. for spans greater than 5' 0".
 2. Values to the right of the bold line exceed the maximum recommended span for multispan conditions. Values neglect slab stiffness of fill and are based on a 150 lb/ft of width concentrated load producing L/240 deflection.
 3. See Slab Tables for the load capacities.
 4. SDI recommends 2 1/2" as the minimum cover for insulating concrete decks. This table uses the 2 1/2" cover to establish a lower limit for diaphragm checks.
 5. Density is presented as an order of magnitude and does not affect the shear strength for insulating fill; f'_c is critical.
 6. Q_t = Nominal Shear Capacity of Support Fastener
 Q_s = Nominal Shear Capacity of Side Lap Fastener

$$G' = \frac{K_2}{K_4 + 3K_1 L_v} + K_3 \text{ (kips/in)}$$

t	.0149	.0179	.0239	.0295	.0358
K_2	440	528	705	870	1056
K_3	260				

Deck	K_4
UFSV	2.83

TABLES



FORM DECK, UF1XV - Insulating Fill Type II, Screw Screw

Deck: $F_y = 80$ ksi Fastener Pattern = 27/3
Type II Insulating Concrete with Embedded Insulation Board

30 pcf $f_c = 125$ psi with 2 1/2" cover over deck

Fastener Support #12 Screw (Q_s)
Side-Lap # 10 screws (Q_s)

Load Type	ASD Ω	LRFD ϕ
All	3.25	0.50
	S_p/Ω	ϕS_n

UF1XV Form Deck Slab Diaphragm Tables

Deck "t"	Side-Lap Conn. / Span	Nominal Shear Strength (S_n), PLF											K_1	
		Span (L_v), Ft.												
		1.5	2.0	2.5	3.0	3.5	4.0	4.5	5.0	5.5	6.0	6.5		
26 gage	0	1551	1342	1217	1133	1074	1029	994	966	943	924	908	1.140	
	1	1807	1534	1371	1261	1183	1125	1080	1043	1013	989	968	0.691	
	Q_s (lb)	2	2064	1727	1525	1390	1293	1221	1165	1120	1083	1053	1027	0.496
	940	3	2321	1919	1679	1518	1403	1317	1251	1197	1153	1117	1086	0.387
	Q_s (lb)	4	2577	2112	1833	1646	1513	1414	1336	1274	1223	1181	1145	0.317
385	5	2834	2304	1986	1775	1623	1510	1422	1351	1293	1245	1204	0.268	
24 gage	0	1831	1552	1385	1273	1194	1134	1087	1050	1020	994	973	1.318	
	1	2173	1809	1590	1444	1340	1262	1202	1153	1113	1080	1052	0.798	
	Q_s (lb)	2	2516	2066	1796	1616	1487	1391	1316	1256	1207	1166	1131	0.573
	1255	3	2859	2323	2001	1787	1634	1519	1430	1358	1300	1251	1210	0.447
	Q_s (lb)	4	3201	2580	2207	1958	1781	1648	1544	1461	1393	1337	1289	0.366
514	5	3544	2837	2412	2130	1928	1776	1658	1564	1487	1423	1368	0.310	
22 gage	0	2092	1748	1542	1404	1306	1232	1174	1129	1091	1060	1033	1.464	
	1	2515	2065	1795	1615	1487	1390	1315	1255	1206	1165	1131	0.887	
	Q_s (lb)	2	2938	2382	2049	1827	1668	1549	1456	1382	1322	1271	1228	0.636
	1549	3	3361	2699	2303	2038	1849	1707	1597	1509	1437	1377	1326	0.496
	Q_s (lb)	4	3784	3017	2556	2250	2030	1866	1738	1636	1552	1483	1424	0.407
634	5	4206	3334	2810	2461	2212	2025	1879	1763	1668	1588	1521	0.344	
20 gage	0	2386	1969	1718	1551	1432	1342	1272	1217	1171	1133	1101	1.612	
	1	2899	2353	2026	1807	1651	1534	1443	1371	1311	1261	1219	0.977	
	Q_s (lb)	2	3412	2738	2334	2064	1871	1727	1615	1525	1451	1390	1338	0.701
	1880	3	3926	3123	2642	2321	2091	1919	1786	1679	1591	1518	1456	0.547
	Q_s (lb)	4	4439	3508	2949	2577	2311	2112	1957	1833	1731	1646	1575	0.448
770	5	4952	3893	3257	2834	2531	2304	2128	1986	1871	1775	1693	0.379	

NOTES

1. Shaded Area does not conform to SDI maximum fastener spacing of 36" o.c. for spans greater than 5' 0".
2. Values to the right of the bold line exceed the maximum recommended span for multispans conditions. Values neglect slab stiffness of fill and are based on a 150 lb/ft of width concentrated load producing L/240 deflection.
3. See Slab Tables for the load capacities.
4. SDI recommends 2 1/2" as the minimum cover for insulating concrete decks. This table uses the 2 1/2" cover to establish a lower limit for diaphragm checks.
5. Density is presented as an order of magnitude and does not affect the shear strength for insulating fill; f_c is critical.
6. Q_s = Nominal Shear Capacity of Support Fastener
 Q_s = Nominal Shear Capacity of Side Lap Fastener

$$G' = \frac{K_2}{K_4 + 3K_1 L_v} + K_3 \text{ (kips/in)}$$

t	.0179	.0239	.0295	.0358
K_2	528	705	870	1056
K_3	260			

Deck	K_4
UF1XV	3.15

TABLES



FORM DECK, UFXV - Insulating Fill Type II, Screw Screw

Deck: $F_y = 80$ ksi Fastener Pattern = 36/4
Type II Insulating Concrete with Embedded Insulation Board

30 pcf $f'_c = 125$ psi with 2 1/2" cover over deck

Fastener Support #12 screws (Q_f)
Side-Lap # 10 screws (Q_s)

Load Type	ASD Ω	LRFD ϕ
All	3.25	0.50
	S_n/Ω	ϕS_n

UFXV Form Deck Slab Diaphragm Tables

Deck "t"	Side-Lap Conn. / Span	Nominal Shear Strength (S_n), PLF											K_1	
		Span (L_v), Ft.												
		3.5	4.0	4.5	5.0	5.5	6.0	6.5	7.0	7.5	8.0	8.5		
26 gage	0	1139	1086	1045	1012	985	963	944	927	913	901	890	0.599	
	1	1249	1183	1131	1089	1055	1027	1003	982	965	949	935	0.411	
	Q_f (lb)	2	1359	1279	1216	1166	1125	1091	1062	1037	1016	997	981	0.313
	940	3	1469	1375	1302	1243	1195	1155	1121	1092	1067	1045	1026	0.253
	Q_s (lb)	4	1579	1471	1387	1320	1265	1219	1181	1147	1119	1093	1071	0.212
385	5	1689	1567	1473	1397	1335	1284	1240	1202	1170	1142	1116	0.183	
24 gage	0	1281	1211	1156	1112	1076	1046	1020	999	980	963	949	0.692	
	1	1428	1339	1270	1214	1169	1131	1099	1072	1048	1027	1009	0.475	
	Q_f (lb)	2	1575	1468	1384	1317	1263	1217	1178	1145	1117	1092	1069	0.362
	1255	3	1722	1596	1498	1420	1356	1303	1257	1219	1185	1156	1130	0.292
	Q_s (lb)	4	1869	1725	1612	1523	1449	1388	1337	1292	1254	1220	1190	0.245
514	5	2016	1853	1727	1626	1543	1474	1416	1366	1322	1284	1251	0.211	
22 gage	0	1414	1327	1259	1205	1160	1123	1092	1065	1042	1021	1003	0.769	
	1	1595	1485	1400	1331	1275	1229	1189	1155	1126	1100	1078	0.528	
	Q_f (lb)	2	1777	1644	1541	1458	1391	1334	1287	1246	1211	1180	1152	0.402
	1549	3	1958	1802	1682	1585	1506	1440	1384	1337	1295	1259	1227	0.325
	Q_s (lb)	4	2139	1961	1823	1712	1621	1546	1482	1427	1380	1338	1302	0.273
634	5	2320	2120	1964	1839	1737	1652	1580	1518	1464	1418	1376	0.235	
20 gage	0	1563	1457	1375	1309	1255	1210	1172	1139	1111	1086	1065	0.847	
	1	1783	1650	1546	1463	1395	1338	1290	1249	1214	1183	1155	0.582	
	Q_f (lb)	2	2003	1842	1717	1617	1535	1467	1409	1359	1316	1279	1246	0.443
	1880	3	2223	2035	1888	1771	1675	1595	1527	1469	1419	1375	1336	0.358
	Q_s (lb)	4	2443	2227	2059	1925	1815	1723	1646	1579	1522	1471	1427	0.300
770	5	2663	2419	2230	2079	1955	1851	1764	1689	1624	1567	1517	0.259	

- NOTES**
- Shaded Area does not conform to SDI maximum fastener spacing of 36" o.c. for spans greater than 5' 0".
 - Values to the right of the bold line exceed the maximum recommended span for multispan conditions. Values neglect slab stiffness of fill and are based on a 150 lb/ft of width concentrated load producing L/240 deflection.
 - See Slab Tables for the load capacities.
 - SDI recommends 2 1/2" as the minimum cover for insulating concrete decks. This table uses the 2 1/2" cover to establish a lower limit for diaphragm checks.
 - Density is presented as an order of magnitude and does not affect the shear strength for insulating fill; f'_c is critical.
 - Q_f = Nominal Shear Capacity of Support Fastener
 Q_s = Nominal Shear Capacity of Side Lap Fastener

$$G' = \frac{K_2}{K_4 + 3K_1 L_v} + K_3 \text{ (kips/in)}$$

t	.0179	.0239	.0295	.0358
K_2	528	705	870	1056
K_3	260			

Deck	K_4
UFXV	3.64

TABLES

FORM DECK, UF2XV - Insulating Fill Type II, Screw Screw

Deck: $F_y = 80$ ksi Fastener Pattern = 30/3
 Type II Insulating Concrete with Embedded Insulation Board

30 pcf $f'_c = 125$ psi with 2 1/2" cover over deck

Fastener Support #12 screws (Q_t)
 Side-Lap # 10 screws (Q_s)

Load Type	ASD Ω	LRFD ϕ
All	3.25	0.50
	S_n/Ω	ϕS_n

UF2XV Form Deck Slab Diaphragm Tables

Deck "t"	Side-Lap Conn. / Span	Nominal Shear Strength (S_n), PLF											K_1	
		Span (L_v), Ft.												
		4.5	5.0	5.5	6.0	6.5	7.0	7.5	8.0	8.5	9.0	9.5		
24 gage	0.0239	0	1095	1057	1026	1000	978	959	943	929	916	905	895	1.078
		1	1209	1160	1119	1086	1057	1033	1012	993	977	962	949	0.678
	Q_t (lb)	2	1323	1262	1213	1171	1136	1106	1080	1057	1037	1019	1003	0.494
	1255	3	1437	1365	1306	1257	1215	1180	1149	1122	1098	1076	1057	0.389
	Q_s (lb)	4	1552	1468	1400	1343	1294	1253	1217	1186	1158	1134	1112	0.320
514	5	1666	1571	1493	1428	1373	1326	1286	1250	1219	1191	1166	0.273	
22 gage	0.0295	0	1184	1137	1099	1067	1040	1016	996	979	963	950	937	1.198
		1	1325	1264	1214	1172	1137	1107	1081	1058	1038	1020	1004	0.753
	Q_t (lb)	2	1465	1391	1329	1278	1235	1198	1166	1137	1113	1091	1071	0.549
	1549	3	1606	1517	1444	1384	1332	1288	1250	1217	1187	1161	1138	0.432
	Q_s (lb)	4	1747	1644	1560	1489	1430	1379	1335	1296	1262	1231	1204	0.356
634	5	1888	1771	1675	1595	1527	1469	1419	1375	1336	1302	1271	0.303	
20 gage	0.0358	0	1284	1227	1180	1142	1109	1081	1056	1035	1016	1000	985	1.319
		1	1455	1381	1320	1270	1227	1191	1159	1131	1107	1085	1066	0.829
	Q_t (lb)	2	1626	1535	1460	1398	1346	1301	1262	1227	1197	1171	1147	0.605
	1880	3	1797	1689	1600	1526	1464	1411	1364	1324	1288	1256	1228	0.476
	Q_s (lb)	4	1968	1843	1740	1655	1582	1521	1467	1420	1378	1342	1309	0.392
770	5	2139	1996	1880	1783	1701	1630	1569	1516	1469	1427	1390	0.334	
18 gage	0.0474	0	1468	1392	1331	1280	1236	1199	1167	1139	1114	1092	1072	1.518
		1	1694	1596	1516	1449	1393	1345	1303	1266	1234	1205	1179	0.954
	Q_t (lb)	2	1921	1800	1701	1619	1550	1490	1439	1393	1353	1318	1286	0.696
	2489	3	2147	2004	1887	1789	1707	1636	1574	1521	1473	1431	1394	0.548
	Q_s (lb)	4	2373	2208	2072	1959	1863	1781	1710	1648	1593	1545	1501	0.451
1019	5	2600	2412	2257	2129	2020	1927	1846	1776	1713	1658	1608	0.384	

NOTES

1. Shaded Area does not conform to SDI maximum fastener spacing of 36" o.c. for spans greater than 5' 0".
2. Values to the right of the bold line exceed the maximum recommended span for multispans conditions. Values neglect slab stiffness of fill and are based on a 150 lb/ft of width concentrated load producing L/240 deflection.
3. See Slab Tables for the load capacities.
4. SDI recommends 2 1/2" as the minimum cover for insulating concrete decks. This table uses the 2 1/2" cover to establish a lower limit for diaphragm checks.
5. Density is presented as an order of magnitude and does not affect the shear strength for insulating fill; f'_c is critical.
6. Q_t = Nominal Shear Capacity of Support Fastener
 Q_s = Nominal Shear Capacity of Side Lap Fastener

$$G' = \frac{K_2}{K_4 + 3K_1L_v} + K_3 \text{ (kips/in)}$$

t	.0239	.0295	.0358	.0474
K_2	705	870	1056	1398
K_3	260			

Deck	K_4
UF2XV	3.57

FOR COMPOSITE DECK, FORM DECK, AND ROOF DECK CONSTRUCTION

1. General

1.1 Scope: This Code is intended to promote safety and quality construction in accordance with good engineering practice. It is designed to assist in the preparation of the sales contract by providing contract details which can be adopted by reference.

1.2 Application: This Code shall govern where building codes, architects' and engineers' plans and specifications or contracts are not complete or clear. There shall be no conflict between this code and any legal building regulation; it shall only supplement and amplify such laws.

1.3 Design: In the absence of ordinances or specifications to the contrary, design shall be in accordance with the current Specifications of the Steel Deck Institute. Steel roof deck and floor deck, both composite and non-composite, may be used in a variety of ways, some of which do not lend themselves to a standard "steel deck" analysis for span and loading. In these cases, other criteria must be considered in addition to those given by the Steel Deck Institute. Make sure that this investigation starts with a review of the applicable codes and that any special conditions are included in the design.

1.4 Plans and Specifications for Bidding: Plans and specifications shall clearly show details and shall be complete as to the

extent of deck and accessories to be furnished by the seller. All dimensions necessary to perform an accurate estimate of the required quantity of materials shall be provided on the structural drawings. Accurately scaled plans may be provided as an alternate to fully dimensioned ones. Acceptance of an estimate based on scaled plans is the responsibility of the buyer.

1.5 Responsibility for Design:

When details of design are specified, the seller shall assume no responsibility other than to furnish materials as specified. When details of design are not specified, the seller shall furnish all materials required in accordance with Section 1.3 of this code.

2. Bidding

2.1 Base Bids:

2.1.1 Roof Deck: Base bids shall include roof deck as shown in plan on structural drawings. Base bid shall also include ridge and valley plates and sump pans per architectural drawings and specifications. No other deck or accessories shall be included unless specified.

2.1.2 Composite Floor Deck and Non-Composite Floor Deck: Base bids shall include deck as shown in plan and only those accessories specifically designated on the structural drawings and called for in the appropriate division of the specifications. No other deck or accessories shall be included unless specified.

2.2 Incomplete Plans and Specifications:

Incomplete plans and specifications shall be bid on the basis that the seller shall

provide material in agreement with the provisions of this code.

2.3 Special Details: Any material required to support the steel deck shall not be included. The design of deck supports shall be the responsibility of the architect and/or engineer of record. Deck shall be furnished in sheet lengths of 6 feet (2.0 m) or greater. Any deck sheets requiring lengths less than 6 feet (2.0 m) shall be field cut by others unless special arrangements are made with individual manufacturers.

3. Drawings and Specifications

3.1 Furnished by the Buyer:

The buyer shall furnish complete architectural plans and specifications, structural steel drawings, and purlin placing plans, all correctly dimensioned.

3.2 Furnished by Seller: The seller shall furnish erection layouts, clearly showing the location of all deck sheets. It is standard for the seller to provide the buyer with one reproducible and three prints of drawings for "approval" and again for "field use". If additional copies are required or desired, they will be provided at an additional cost at the discretion of the seller.

3.3 Discrepancies: The architect's plans shall be assumed to be correct in the absence of written notice from the buyer to the contrary. When structural steel or purlin placing plans do not agree with the architect's plans, the structural plans shall be considered as a written notice of change of plans.

3.4 Approval: The erection layouts shall be submitted to the buyer for approval unless the buyer

Code of Standard Practice

instructs the seller to submit same directly to the architect or waives his right of approval. The buyer (or architect) shall return one copy marked with his approval or with such corrections as he may deem necessary. **Resubmission of approval drawings, if required, shall be made only after all requested dimensions and information are provided by the approving body.** The seller shall not start shop work prior to final approval of his drawings unless such approval is waived.

The deck manufacturer is not responsible for putting a professional seal or signature on erection drawings. Erection drawings are made to show the deck products as an overlay on the structural or architectural plans and as such the drawings interpret the job requirements set forth by the designer. If the deck manufacturer were to check and seal erection drawings, it would subvert that important function.

3.5 Changes by Buyer After Approval: When changes in the project scope as contracted are made via revised contract drawings, steel erection drawings, modified approval drawings, response to RFI's, etc., an extra for material and/or redetailing costs shall be paid by the buyer at a price agreed upon by the buyer and seller.

Although certain collateral materials are not supplied by the steel deck manufacturer, it is the desire of the Steel Deck Institute to have certain principles followed in specifying and furnishing these collateral materials in order to provide a satisfactory deck assembly. This code is not intended

to encroach upon the standard practices of the related industries, but is intended to supplement and amplify specifications pertaining to their products.

3.6 As Built Drawings: When included in the purchase agreement, erection layouts will be provided by the deck manufacturer based upon complete specifications, architectural and structural plans, and steel erection plans supplied by the buyer. The erection layouts shall be submitted to the buyer for approval unless the buyer instructs the seller to submit same directly to the architect or waives his right of approval. The buyer (or architect) shall return one copy marked with his approval or with such corrections as he may deem necessary. The seller shall not start shop work prior to final approval of his drawings unless such approval is waived. Once final approval drawings or a waiver has been received, distribution (field use) drawings will be prepared, and deck fabrication may commence. Changes to the scope of work or to the deck and/or related accessories subsequent to the issuance of distribution drawings, shall be incorporated into the erection layouts, by those making the changes. The deck manufacturer is not responsible for "as built" drawings.

4. General Provisions

4.1 Insulation: All steel roof decks shall be covered with a material of sufficient insulating value to prevent condensation under normal occupancy conditions. Insulation shall be adequately attached to the steel roof deck by adhesives or mechanical fasteners.

Insulation materials shall be protected from the elements at all times during their storage and installation.

Phenolic foam insulation in contact with steel deck can be very corrosive when water is present. Phenolic foam insulation is not recommended for use with steel deck.

Polystyrene foam insulation applied directly to steel deck without a thermal barrier may require sprinklers to meet fire rating requirements. Consult the local codes for this construction.

4.2 Acoustical Batts: When open rib acoustical deck is provided, any sound absorbing acoustical batts shall be installed in the field by the roofing contractor. Batts shall be shipped and stored at the jobsite in such a manner as to ensure protection until installation. If acoustical batts become wet, they shall be allowed to thoroughly dry without being compressed before installation or replaced if contaminated.

A. Mold & Fungi Resistance of Insulating Materials (Fiberglass)

Fiberglass does not breed or promote fungal growth. All fiberglass typically utilized by member companies is resistant to fungal growth and complies with ASTM C1338, "Standard Test Method for Determining Fungi Resistance of Insulating Materials and Facings."

Since mold spores exist in almost every environment, according to the Environmental Protection Agency, the key to mold control is moisture control.

Code of Standard Practice

Proper care should be taken prior to installation. Insulation should be kept dry, off the ground, and protected from water in accordance with ASTM C1320 recommendations.

Please review the North American Insulation Manufacturer's Association's (NAIMA) Insulation Facts # 70, "**Fiber Glass Building Insulation Products: The Facts About Mold Growth**". For additional information on this subject, visit their website at www.naima.org.

4.3 Roof Coverings: A suitable roof covering shall be applied over the insulation.

4.4 Sheet Metal Work: All closures, flashing, etc., used in deck construction, unless otherwise specified, shall be detailed and furnished by the sheet metal contractor.

4.5 Field Painting: In some instances, field painting applied either as a full finish coat or as a touch-up may be a requirement. If field painting is intended, it is recommended that the steel surface, whether galvanized or primer painted, be checked for compatibility by the painting contractor, following the recommendations of the field coating manufacturer, particularly with regard to ambient application temperatures and humidity, cleanliness, surface moisture and surface preparation if required.

In most cases, deck welds are removed from a corrosive environment when the roof is installed and no weld touch up paint or cold galvanizing is necessary. In these instances where the welds are left exposed to a corrosive atmosphere, the weld

should be wire brushed and coated with an approved substance.

A typical procedure for field painting should include:

- Surfaces must be clean, dry, and free of oil, grease and dirt.
- Test-patch an area to assure compatibility.
- Apply paint following the manufacturer's recommendations.

Note: Field Painting is the sole responsibility of the painting contractor to assure that the surface is properly prepared and that the coating is properly applied. The deck manufacturer will not accept responsibility for adhesion or compatibility of the field coating or for other causes leading to unsatisfactory painting results.

4.6 Shear Connectors: None of the member companies of the Steel Deck Institute (SDI) manufacture or furnish shear studs. As manufacturers of steel deck, the SDI members are not in a position to properly design the shear connectors to meet the building designer's intent. Consequently, the layout, design, numbering or sizing of shear connectors is not the responsibility of the deck manufacturer.

It is the Engineer of Record's responsibility to determine the quantity of shear connectors required for each compositely designed beam and show that quantity on the project drawings. The determination of shear connector quantities for purlin beams must take into account the profile of the steel deck. Shear connector quantities for girder beams must also consider the steel deck profile. The steel deck rib height, average opening width, and the stud length and placement are the key factors to determine whether a reduction factor must be applied to the shear connector strength. The

AISC Specification for Structural Steel Buildings provides the design method to determine any reduction factors to be considered when using shear connectors in conjunction with steel deck. Table A is a summary of the "minimum" average rib width and width/height ratios of all SDI members. This average width value can be safely used in the AISC shear connector strength reduction formulas.

The deck detailers for member companies of the SDI will assume the shear connector strength reduction factors have already been incorporated into the design when detailing composite deck projects. Since the steel deck manufacturer doesn't furnish the shear connectors, they normally are not shown on the deck erection drawings. If a deck detailer does prepare a separate stud installation drawing, the detailer shall indicate the number of studs shown on the contract documents. The deck detailer shall not make adjustments without revised contract drawings.

Compliance with this criteria will ensure the correct number of shear connectors will be specified to meet the requirements of the building design.

COMPOSITE DECK PROFILE	W_r	W_r/h_r
1.5" x 6"	2.125"	1.417
1.5" x 12"	6"	4.000
2" x 12"	6"	3.000
3" x 12"	6"	2.000
Inverted 1.5" x 6"	3.875"	2.583
2" Keystone	4.60"	2.300

TABLE A

Code of Standard Practice

4.7 Oil Canning: Steel sheets of thicknesses typically used in the manufacture of steel deck products may exhibit a degree of waviness in their flat surfaces. This is a condition commonly referred to as “oil canning.”

Oil canning is an inherent condition with light gage cold-formed metal products, and can result from residual stresses induced or redistributed during coil production, slitting, perforating, forming, or fabrication of steel deck. Improper deck handling, installation, or attachment to misaligned steel supports can also cause oil canning.

In general, oil canning is an aesthetic condition with no effect on the structural integrity of the deck. Since many uncontrollable factors can lead to oil canning, the manufacturer assumes no responsibility for the cost of actions taken in response to an oil canning condition. Oil canning shall not be a cause for rejection of steel deck products.

4.8 Treated Lumber: Fire retardant treated wood contains chemicals that can develop a corrosive environment when adequate moisture and heat are present. Precautionary measures should be taken by the designer to prevent such an environment when using fire retardant treated wood with steel deck.

Corrosion of steel deck products in direct contact with pressure treated lumber has become an issue due to the change in products used in treating pressure treated lumber.

The pressure treated lumber industry now treats lumber with

products referred to as ACQ (Alkaline Copper Quat) and CA-A or CA-B (Copper-azole). Pressure treated lumber treated with these products have shown to be highly corrosive when in direct contact with sheet steel.

The Steel Deck Institute recommends a barrier of Water and Ice Shield or equivalent be used between pressure treated lumber and steel deck products or accessories.

4.9 Weld Washers: The capacity values for welds used in the *Diaphragm Design Manual* tables provided by SDI are **based on welds without washers** for material thickness equal or greater than .028 in. (0.71 mm). The appropriate safety and resistance factors allow for normal inconsistency in workmanship.

Welding and other types of **attachments should always be monitored on site** to verify that the proper size attachment is provided and the proper procedures are followed to produce attachments that will behave in accordance with their theoretical capacity.

Furthermore the use of washers for welded attachment to steel supports can be detrimental for the following reasons:

- The size of the washers provided by the deck installer may not allow proper contact at the bottom of the standard flutes;
- There are no washers that will allow welding to the support on either side of an interlocking side lap which is a very important attachment since it is often a controlling failure mode for diaphragm action;

- Welding with washers requires special welding procedures that require more welding time in order to produce the proper fusion between weld material, steel washer, steel deck, and steel support.

For those reasons, the **SDI does not recommend the use of welding washers to weld steel deck to support for sheet material thickness equal or greater than .028 in. (0.71 mm).**

4.10 Conduits In Deck Slabs: Conduits are permitted in deck slabs subject to local code requirements and fire rating considerations. When conduit sizes are 1" (25 mm) or less in diameter, or less than 1/3 the concrete cover, and no crossovers occur, and conduit is spaced at least 18" (457 mm) apart with 3/4" (19 mm) minimum cover, conduit may be permitted in the slab unless further restricted by the design documents.

4.11 Fire Ratings: Many fire rated assemblies that use composite floor decks are available. Consult a SDI member or manufacturer for a list or ratings.

In the Underwriters Laboratories *Fire Resistance Directory*, the composite deck constructions show hourly ratings for restrained and unrestrained assemblies. ASTM E119 provides information in appendix X3 called *Guide for Determining Conditions of Restraint for Floor and Roof Assemblies and for Individual Beams*. After a careful review of this guide, the Steel Deck Institute determined that all interior and exterior spans of multispan deck properly attached to bearing walls are restrained.

Code of Standard Practice

In fact, there is almost no realistic condition that a composite deck-slab could not be considered to be restrained - except perhaps a single span deck system which is unattached to framing or a wall in order to provide a removable slab.

4.12 Fireproofing: The steel deck manufacturer shall not be responsible for ensuring the bonding of fireproofing. The adherence of fireproofing materials is dependent on many variables; the deck manufacturer (supplier) is not responsible for the adhesion or adhesive ability of the fireproofing.

4.13 Acceptable Steels:

Historically SDI has stated that steel shall conform to ASTM designation A1008 for cold-rolled products (painted or non-galvanized) or A653 for galvanized products. The discontinued predecessors of these ASTM specifications, e.g. A245, A611, and A446, were noted in earlier SDI publications. The AISI Standard, "North American Specification for the Design of Cold-Formed Steel Structural Members," governs the design of steel roof deck, composite steel floor deck, and non-composite steel form deck. Other structural steels (SS) or high-strength low-alloy steels (HSLAS or HSLAS-F) listed in Section A2.1 of the AISI Standard's 2001 Edition are permitted in the manufacture of decking products. The 2004 Supplement to the AISI Standard applies. The following also apply:

1. The acceptable steel grades are limited in the AISI Section A2.1 table.

2. Ductility limits (AISI Section A2.3) apply when specifying structural steel not listed in Section A2.1.
3. The use of Grade 80 steel conforming to ASTM A653, A1008, A792, and A875 and other steel is permitted in roof and floor decking (AISI Section A2.3.2). Certain design restrictions apply to all decking and particularly to composite floor deck.
4. Consider the suitability of metallic finishes for the particular decking application, e.g. SDI does not recommend aluminized steels or aluminum-zinc alloy coated steels in composite floor deck, and some fire rating applications require galvanized steel. *(These examples would preclude A792 and A875 in floor deck; however, these same steels may be suitable in roof deck applications.)*
5. Limit design to the specified and ordered minimum yield strength and not that indicated by mill reports.
6. The design thickness limit is specified in the SDI Design Manual and the AISI Standard (AISI Section A2.4).

4.14 Parking Garages: Composite floor deck has been used successfully in many parking structures around the country; however, the following precautions should be observed:

1. Slabs should be designed as continuous spans with negative bending reinforcing over the supports;

2. Additional reinforcing should be included to deter cracking caused by large temperature differences and to provide load distribution; and,
3. In areas where salt water; either brought into the structure by cars in winter or carried by the wind in coastal areas, may deteriorate the deck, protective measures must be taken. The top surface of the slab must be effectively sealed so that the salt water cannot migrate through the slab to the steel deck. A minimum G90 (Z275) galvanizing is recommended, and, the exposed bottom surface of the deck should be protected with a durable paint. The protective measures must be maintained for the life of the building. If the protective measures cannot be assured, the steel deck can be used as a stay in place form and the concrete can be reinforced with mesh or bars as required.

5. Construction Practice

5.1 Site Storage: It is the position of the Steel Deck Institute (SDI) that the deck manufacturer cannot assume responsibility for damage to steel deck resulting from improper storage protection in the field when the deck is no longer under the manufacturer's control. Neither will the deck manufacturer accept responsibility for steel deck that is delivered to the site and stored for an excessive length of time. This applies whether the steel deck was stored properly or not.

The SDI Manual of Construction with Steel Deck (MOC2) provides the basic guideline for proper storage of steel deck:

Steel deck shall be stored off the ground with one end elevated to provide drainage, and shall be protected from the elements with a waterproof covering, ventilated to avoid condensation.

For more information on this issue, please see the SDI White Paper entitled "JOBSITE STORAGE REQUIREMENTS FOR STEEL DECK".

If aesthetics of the erected product is an important consideration, special care must be taken to protect the steel deck during the pre-erection storage as well as throughout the installation process.

5.2 Coil Ordering Practices: The steel deck industry adopted the Voluntary Lubricant Compliance Program (VLCP) developed by the Steel Coalition which consists of manufacturers of sheet steel products used for construction. The VLCP requires the removal of lubricants from the surfaces of all steel decks, regardless of finish, to minimize the slip hazard during the construction process.

Prior to the VLCP, it was common practice to order sheet steel coils with a light film of lubricant to protect the steel from moisture during coil storage and to provide lubrication during the roll-forming process. An additional benefit of the light lubricant film was additional protection of the deck finish while stored in bundles at the jobsite.

With the removal of lubricants from the steel deck surfaces, proper jobsite storage of steel deck has become even more critical.

5.3 Protection After Erection:

Steel deck shall be protected to avoid any deterioration of the structural integrity of the deck. This protection shall include avoiding extended exposure to aggressive atmospheric conditions, protection from erection traffic and/or handling that might be abrasive to the deck finish, and protection against interior conditions that would cause excess moisture to form on the underside of the deck. Deck protection after erection and any cost associated shall be "by others" and is not the responsibility of the deck manufacturer.

Some steel decks are utilized as "finished ceiling" products and shall be protected from moisture and must never be subjected to corrosive substances such as salts, fertilizers or other chemicals or to prolonged contact with dissimilar materials. All steel decks must be protected from erection operations or during site storage that could distort the panel's configuration.

Acoustical steel decks utilize fiberglass insulation batts for sound absorption; hence, protection from moisture, rain, snow, dirt, mud, etc. is necessary. Do not install (field applied) loose insulation batts in the flutes of decking until just before roof system installation. Likewise, cellular acoustical deck with shop-installed insulation batts requires proper site storage and special protection after deck erection before installation of the roofing system.

5.4 Anchorage: The deck contractor should not leave unattached deck at the end of

the day as the wind may displace sheets and cause injury to persons or property. If studs are being welded to the top flange of the beams, deck sheets should be butted over the supports.

Custom Shapes and Decks

Our 32' tandem brake provides the capacity to fill special deck needs. We will be glad to optimize designs and assist your engineering staff; quote prices and check material availability; and brake material in the lengths shown in the table. 34' lengths are available with gage material.

A36 STEEL

Metal Thickness	1"	3/4"	1/2"	1/4"
Maximum Length	7'	10'6"	15'6"	32'

CAPABILITIES INCLUDE:

1. Forming metals - Carbon or Stainless Steel, Aluminum.
2. Providing a variety of finishes - galvanized, zinc/aluminum alloy, prepainted coils.
3. Custom hole punching.
4. Spot welding to allow hybrid fabrications with roll formed products.

EXAMPLES:

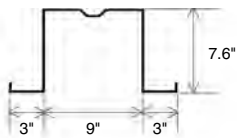

12 gage 28' long deck was used to roof an existing tank. 15" slab; 6" wide ribs used as reinforced concrete joists at 15" centers.

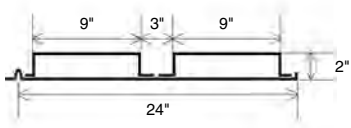

12 gage top and 16 gage bottom cellular deck used to span between bottom beam flanges in a powerplant. Very thick slab - flat underside left exposed.

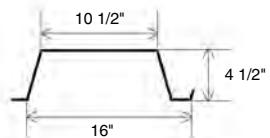

16 gage long span canopy deck made from prepainted steel.

International Units Conversion Tables

GALVANIZING DESIGNATIONS

Customary Units (total of both sides)	SI Units (total of both sides)	Approximate Total Thickness (both sides)	
		inches	mm
G30 0.30 oz./ft. ² min.	Z090 90 g/m ² min.	0.0005	0.013
G60 0.60 oz./ft. ² min.	Z180 180 g/m ² min.	0.0010	0.026
G90 0.90 oz./ft. ² min.	Z275 275 g/m ² min.	0.0015	0.039

The weights shown are the total for both sides of the sheet and are minimum values.

STEEL PROPERTIES

ASTM Number	Customary Units, ksi			SI Units, MPa		
	F _y	F _u	F*	F _y	F _u	F*
A1008 grade 33	33	48	20	230	330	140
A1008 grade 40	40	52	24	275	360	165
A1008 grade 50	50	65	30	340	410	205
A1008 grade 80	80	82	36	550	565	250
A653 grade 33	33	45	20	230	310	140
A653 grade 40	40	55	24	275	380	165
A653 grade 50	50	65	30	345	450	205
A653 grade 80	80	82	36	550	570	250

* ASD Design stress in bending.

CONVERSION FACTORS FOR DECK PRODUCTS

m = Meters; **mm** = Millimeters; **kg** = Kilograms; **N** = Newtons; **Pa** = Pascals;
kPa = Kilopascals; **MPa** = Megapascals

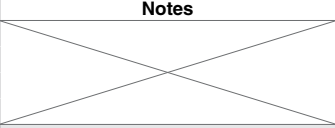
To Convert	To	Multiply by	Notes	
m	ft.	3.28		
m	in.	39.4		
mm	in.	0.0394		
m ²	sq. ft.	10.8		
m ²	sq.	0.108		1 sq. = 100 ft. ²
mm ²	sq. in.	0.00155		
mm ² /m	sq.in. / ft.	0.000473	reinforcing steel area; concrete area available for shear	
mm ⁴	in. ⁴	2.40 x 10 ⁻⁶	moment of inertia	
mm ⁴ /m	in. ⁴ / ft.	0.732 x 10 ⁻⁶	deck moment of inertia per unit width	
mm ⁴ /mm	in. ⁴ / ft.	0.732 x 10 ⁻³		
mm ³	in. ³	61.0 x 10 ⁻⁶	section modulus	
mm ³ /mm	in. ³ / ft.	18.6 x 10 ⁻⁶	deck section modulus per unit of width	
mm ³ /m	in. ³ / ft.	18.6 x 10 ⁻³		
mm	mils	39.4	1 mil = 0.001 inches, paint thickness	
m ³	ft. ³	35.29	concrete volume	
m ³	yds. ³	1.307	concrete volume	
m ³ /m ²	ft. ³ / ft. ²	3.28	concrete vol. per unit area - slab vol.	
kg	lbs.	2.20	mass unit - NOT to be used for stress or deflection calculations	
kg/m ²	lbs. / ft. ²	0.205	mass units	
g/m ²	oz. / ft. ²	3.28 x 10 ⁻³	galvanizing	
kg/m ³	lbs. / ft. ³	0.0624	concrete density	
kg/m ²	Pa	9.81	use pascals (N/m²) for stress and deflection calculations	
N	lbs. (force)	0.225	concentrated loads, stress and deflection calcs	
Nm	lbs. ft.	0.738	bending moment	
Nm	in.	8.85	bending moment	
N/m	lbs. / ft.	0.0685	line loads; diaph. strength or stiffness	
kPa	lbs. / ft. ²	20.9	1 pascal = 1 N/m ² ; live loads; pressure	
MPa*	lbs. / in. ²	145	stress; Modulus of Elasticity (E)	

* For steel deck, the modulus of elasticity (E) is 210 000 MPa.

CUSTOM SHAPES, METRIC CONVERSION

Standard Finishes Commonly Available on USD Products

Type	I	II	III	IV	V	VI
Steel ASTM Spec.	A653	A1008	A1008	A653	A653	A1008
Product	Galv. G60, G90	Phos/Ptd	Prime Ptd.	Galv.+ Paint	Finish Paint	Uncoated
1 1/2" & 3" Roof Deck	X		X	X	X	
4 1/2", 6", 7 1.2" J, H, LS Roof Deck	X					
1 1/2", 2", 3" Composite Deck	X	X		X		
UFS, UFX, UF2X (Form Deck)	X			X	X	X
LF2X, LF3X (Form Deck)	X	X				
HPD (Heavy Plank Deck Form)	X					

The table represents normal inventories. Each finish may be available on any product on special order with sufficient lead time.

Notes – Roman numerals in the table correspond to those in the notes. These guidelines and comments are not intended to overrule the designer's own experience.

- I. A.** Check UL Fire Resistance Directory for finish requirements. **Galvanized** deck should be used on roof constructions with sprayed fire resistive material (SFRM). However classified paints are acceptable in some designs with SFRM but restrictions can apply in those designs.
- B.** Galvanized Deck (G90) is recommended for high humidity areas or unenclosed areas. High humidity areas can include plenums created between the deck and dropped ceilings.
- C.** Galvanized Deck is recommended with top side insulation boards fastened to roof deck with piercing fasteners. Fasteners are typically by the roofing contractor.
- D.** Canam recommends galvanized deck for all acoustic deck, cellular deck, and for most exposures.
- E.** Canam conforms to the Voluntary Lubricant Compliance Program (VLCP) and white rusting is possible in bundles without proper job site storage procedures. VLCP means the product will be free of any significant residue when it leaves the plant. VLCP helps prevent slips.
- II. A. Phos/Ptd** means the floor deck is only painted on the exposed side – the top side should develop tight rust before the concrete is placed and the deck should not be exposed for long periods.
- B.** Use only for interior applications – i.e. offices, hotels.
- C.** Check UL Directory – See Note I.A.
- D.** Standard primer is gray but white is available on request. Only gray can receive SFRM – Note I.A.
- III. A. Prime Ptd.** Standard primer is applied over clean bare (cold rolled) steel. The deck primer is intended for use as a temporary and provisional coating, and is not to be considered a “finished coat”. Standard gray primer is compatible with many field applied finish paints. However, Canam is not responsible for adhesion of field applied coatings. The field applicator is responsible for the compatibility of any field applied coatings with Canam’s primers. Deck primer is frequently left exposed in warehouses and manufacturing plants and used with suspended ceilings.
- B.** Use for ballasted roofs or adhered systems – See Note I.C.
- C.** Salt Spray (and other) test results are available on request.
- D.** Standard primer is gray. White primer is available on request. White primer is not recommended as a final coat. For enhanced performance, application of white primer over a galvanized coating is recommended. Special care is required in jobsite handling and storage with white paint – Background is provided in the SDI position paper, [JOBSITE STORAGE REQUIREMENTS GALVANIZED OR PAINTED STEEL DECK](#). Only standard gray primer is compatible with SFRM – Note I.A.
- E.** Painted decks may be used in UL designs that include suspended ceilings—G0XX, G2XX, G4XX, G5XX, P0XX, P2XX, P4XX, P5XX. – See Note 1.A.
- IV. A. Galv. + Paint** means the primer is factory applied over galvanized steel. A G60 minimum coating is recommended. Primer is as described in III.
- B.** This is most economical when a final field applied coat is applied. –See Note 111.A.
- C.** Use in High Humidity areas.
- D.** With sufficient lead time and quantity special primers can be applied to work with field coatings in natatorium applications – G90 minimum is recommended.
- E.** Paint on bottom only for form and composite deck to allow chemical bond.
- F.** Cellular deck is available with a standard gray (dark tint) primer on the bottom plate (flat side). Weld marks (from shop welding) will be evident on the bottom plate. Canam is not responsible for touch up of weld marks on the bottom plate of cellular deck.
- V. A. Finish Paint.** Finish coats of paint can be applied (pre-roll forming and / or welding and post roll forming and / or welding) to all of Canam profiles (cellular and non-cellular). Consult your local Canam Sales Representative or our Engineering Department for available options. Almost any color is possible however to be economical, the order should be at least 20,000 square feet.
- B.** Special coil-coated and post-manufacturing paint finishes are available for our acoustic deck products (cellular and non-cellular). Consult Canam Engineering Department or your local Sales Office for additional information.
- C.** Screwed side-laps are recommended and power actuated fastener should be used at supports.
- D.** When roof deck will be used as exposed cladding, finish coats are recommended and the minimum galvanized coating should be G90. Other sealing considerations may apply.
- VI. A. Uncoated** means there is no coating at all. It is commonly referred to as “black” steel.
- B.** This should not be specified when prolong exposure is expected prior to building enclosure.

ACI, Farmington Hills, MI

Building Code Requirements for Structural Concrete (ACI 318-08)

AISC, Chicago, IL

Steel Construction Manual, Thirteenth Edition

Hanagan, Linda, "Floor Vibration Serviceability: Tips and Tools for Negotiating a Successful Design", *Modern Steel Construction* April 2003

Ruddy, John, "Ponding of Concrete Deck Floors", *Engineering Journal*, 3rd Quarter 1986

AISI, Washington, DC

North American Specification for the Design of Cold-Formed Steel Structural Members, 2007 Edition (ANSI/ AISI S100-2007)

Cold-Formed Steel Design, 2002 Edition (SG03-1-CFSManual-0903-5K-AP)

ASCE, Reston, VA

Minimum Design Loads for Buildings and Other Structures, ASCE 7- 05

AWS, Miami FL

Structural Welding Code-Steel (ANSI/AWS D1.1-2008)

Structural Welding Code-Sheet Steel (ANSI/AWS D1.3-2008)

FM Global, Norwood, MA

Approval Guide, (P7825)

Property Loss Prevention Data Sheets 1-28, *Wind Design*

Property Loss Prevention Data Sheets 1-29, *Roof Deck Securement and Above-Deck Roof Components*

MCA, Glenview, IL

A Primer on Diaphragm Design

SDI, Lake in the Hills, IL

Composite Deck Design Handbook, March 1997, (CDD2)

Design Manual for Composite Deck, Form Decks and Roof Decks, Publication No. 31

Designing with Steel Form Deck, 2003, (Form)

Diaphragm Design Manual, Third Edition, (DDM03)

Job Site Storage Requirements for Steel Deck, (JS)

Manual of Construction with Steel Deck, Second Edition, (MOC2)

Metal Deck & Concrete Quantities, (MDCQ)

Roof Deck Construction Handbook, November 2000 (RDCH1)

Standard Practice Details, May 2001, (SPD2)

SJI, Myrtle Beach, SC

Standard Specifications Load Tables & Weight Tables for Steel Joists and Joist Girders, 42 Edition

Vibration of steel joist-concrete slab floors, Technical Digest No. 5, March 1988

UL, Northbrook, IL

Fire Resistance Directory – Volume 1, 2007



DM5-Rev 5  **CANAM** Solutions + Service PAGE: DL()

DELIVERY: **Manufacturers of United Steel Deck Products**

ORDER NO.: **JOB LOCATION**

JOB NAME: **JOB STATUS**

CUSTOMER NAME:

DETAILING OFFICE: **Customer List** **TEK/1 SCREWS** **QUAN.**

DETAILER: **CHECKER:** **TEK/3-12 SCREWS** **QUAN.**

TEK/4 SCREWS **QUAN.**

TEK/5 SCREWS **QUAN.**

TOTAL SQUARES THIS SHEET:

FINISH REMARKS

GAGE	PRODUCT	COVERAGE	FINISH	PAINT	STEEL
					Fy =
WELDING WASHERS:		UL LABELS REQ'D	PLEASE CIRCLE YES OR NO FOR ITEMS INDICATED	MILL CERTIFICATION	HANGER TABS
Yes	No	Yes	No	Yes	No
QUAN.: <input type="text"/>					STANDARD FINISH FOR PTD DECK IS GRAY TOP & BOTT.
SPECIAL INSTRUCTIONS					NON PIERCING

PLEASE PROVIDE A SEQUENCE AND BUNDLE NUMBER.
EXAMPLE: SEQUENCE 1 BUNDLE A SHOULD BE SHOWN AS 1A

SHEET PER BUNDLE: MAXIMUM WEIGHT PER BUNDLE:

SEGMENT DESCRIPTION: SEGMENT NUMBER:

	PC MK	LENGTH		SeqBundle	SeqBundle	SeqBundle	SeqBundle	SeqBundle	SeqBundle
		FT.	INCH						
1									
2									
3									
4									
5									
6									
7									
8									
9									
10									
11									
12									
13									
14									
15									
16									

Plant [1]
Canam Steel Corporation
14 Harmich Road
South Plainfield, NJ 07080-4804
Phone: 908-561-3484
Fax: 908-561-6772

Plant [2]
Canam Steel Corporation
140 South Ellis Road
Jacksonville, Florida 32254
Phone: 904-781-0898
Fax: 904-781-4090

Plant [3]
Canam Steel Corporation
9 Unyrite Drive
Peru, IL 61354
Phone: 815-224-9588
Fax: 815-224-9590

Please go to our website (www.canam.ws) for additional deck and accessory bills of material and sample bills.

INSTRUCTIONS: A bill of material must accompany each deck order when sheet lengths are specified by the customer. Prepare a separate material list for each deck type, gage, cover width and finish. Standard minimum length is 6'-0". Recommended maximum sheet lengths for decks 20 gage and thinner is 33'-0". Recommended maximum length for decks heavier than 20 gage is 25'-0". Roof and Form deck lengths should be listed in 1" increments (Standard tolerance is +/- 1/2" - round up). Composite deck lengths should be listed in 1/2" increments (Standard length tolerance is +0"/-1/4" - round down).

Deck List

BILL OF MATERIALS



Factory Mutual
System
www.fmglobal.com



Steel Deck
Institute
www.sdi.org



International
Code Council
www.iccsafe.org



Canadian
Welding
Bureau
www.cwbgroup.com



Canadian
Institute of Steel
Construction
www.cisc.ca



Underwriters
Laboratories
Inc.®
www.ul.com



American
Institute of Steel
Construction Inc.
www.aisc.org



Steel Joist
Institute
www.steeljoist.org



Steel Plus
Network®
www.steelplus.com



www.canam.ws

Publications

- Joist Catalog
- Steel Deck
- Purlins and Girts

Canam Lists

A selection of joist design documents is available as downloadable PDFs at www.canam.ws. Go to the Documentation Center:

- Joist List
- Joist Girder List
- Bridging and Accessories List
- Take-off Sheet



Canam United States
www.canam.ws

Maryland
Head Office, Plant and Sales Office – AISC, SJI

4010 Clay Street, PO Box 285
Point of Rocks, Maryland
21777-0285
Telephone: 301-874-5141
Toll-free: 1-800-638-4293
Fax: 301-874-5685

Florida
Plant and Sales Office – AISC, SJI, SDI

140 South Ellis Road
Jacksonville, Florida 32254
Telephone: 904-781-0898
Toll-free: 1-888-781-0898
Fax: 904-781-4090

Missouri
Plant and Sales Office – AISC, SJI

2000 West Main Street
Washington, Missouri 63090-1008
Telephone: 636-239-6716
Fax: 636-239-1714

Washington
Plant and Sales Office – AISC, SJI, ICC

2002 Morgan Road
Sunnyside, Washington 98944
Telephone: 509-837-7008
Toll-free: 1-800-359-7308
Fax: 509-839-0383

SALES OFFICES

Massachusetts
50 Eastman Street
Easton, Massachusetts 02334-1245
Telephone: 508-238-4500
Fax: 508-238-8253

Missouri/Kansas
401 South West Ward Road,
Suite 210
Lee's Summit, Missouri 64081
Telephone: 816-554-6900
Fax: 816-554-6901

Pennsylvania
1401 North Cedar Crest Boulevard,
Suite 50
Allentown, Pennsylvania 18104
Telephone: 610-432-1600
Fax: 610-432-6900

Washington
240 North West Gilman Boulevard,
Suite G
Issaquah, Washington 98027
Telephone: 425-392-2935
Fax: 425-392-3149



New Jersey
Plant and Sales Office – SDI
14 Harmich Road
South Plainfield, New Jersey 07080
Telephone: 908-561-3484
Toll-free: 1-800-631-1215
Fax: 908-561-6772

Illinois
Plant and Sales Office – SDI
9 Unytite Drive
Peru, Illinois 61354
Telephone: 815-224-9588
Fax: 815-224-9590

Florida
Plant and Sales Office – AISC, SJI, SDI
140 South Ellis Road
Jacksonville, Florida 32254
Telephone: 904-781-0898
Toll-free: 1-888-781-0898
Fax: 904-781-4090



Canam Canada
www.canam.ws

Alberta
Plant and Sales Office – BCS, SJI
323 - 53rd Avenue South East
Calgary, Alberta T2H 0N2
Telephone: 403-252-7591
Toll-free: 1-866-203-2001
Fax: 403-253-7708

British Columbia
Sales Office
95 Schooner Street
Coquitlam, British Columbia
V3K 7A8
Telephone: 403-252-7591
Toll-free: 1-866-203-2001
Fax: 604-523-2181

New Brunswick
Sales Office
95, rue Foundry
Heritage Court, Suite 417
Moncton, Nouveau-Brunswick
E1C 5H7
Telephone: 506-857-3164
Toll-free: 1-800-210-7833
Fax: 506-857-3253

Ontario
Plant and Sales Office – BCS, SJI
1739 Drew Road
Mississauga, Ontario L5S 1J5
Telephone: 905-671-3460
Toll-free: 1-800-446-8897
Fax: 905-671-3924

Quebec
Management
11505, 1^{re} Avenue, bureau 500
Saint-Georges (Québec) G5Y 7X3
Telephone: 418-228-8031
Toll-free: 1-877-499-6049
Fax: 418-227-5424

Plant – ISO 9001:2000, BCS, SJI, AISC, ICCA
115, boulevard Canam Nord
Saint-Gédéon-de-Beauce (Québec)
G0M 1T0
Telephone: 418-582-3331
Toll-free: 1-888-849-5910
Fax: 418-582-3381

Plant and Sales Office – ISO 9001:2000, BCS, ICCA
200, boulevard Industriel
Boucherville (Québec) J4B 2X4
Telephone: 450-641-8770
Toll-free: 1-800-463-1582
Fax: 450-641-8769

Sales Office
270, chemin Du Tremblay
Boucherville (Québec) J4B 5X9
Telephone: 450-641-4000
Toll-free: 1-866-466-8769
Fax: 450-641-9585



Canam Group
www.canamgroup.ws

Quebec
Head Office
11535, 1^{re} Avenue, bureau 500
Saint-Georges (Québec) G5Y 7H5
Telephone: 418-228-8031
Toll-free: 1-877-499-6049
Fax: 418-228-1750

Administrative Center
270, chemin Du Tremblay
Boucherville (Québec) J4B 5X9
Telephone: 450-641-4000
Toll-free: 1-866-506-4000
Fax: 450-641-4001

CERTIFICATION:	
AISC	= American Institute of Steel Construction
CISC	= Canadian Institute of Steel Construction
CWB	= Canadian Welding Bureau
IAS	= International Accreditation Service
ICC	= International Code Council
ISO	= International Organization for Standardization
SDI	= Steel Deck Institute
SJI	= Steel Joist Institute

PLANTS AND SALES OFFICES

NOTES

NOTES



Better Building **Solutions**



U.S. Headquarters
Point of Rocks
4010 Clay Street, PO Box 285
Point of Rocks, Maryland
21777-0285
Telephone: 301-874-5141
Toll free: 1-800-638-4293
Fax: 301-874-5685

www.canam.ws