

*Allen-Bradley*

## **Stepper Controller Module**

(Catalog No. 1746-HSTP1)

**User Manual**

**Rockwell  
Automation**

## Important User Information

Because of the variety of uses for the products described in this publication, those responsible for the application and use of this control equipment must satisfy themselves that all necessary steps have been taken to assure that each application and use meets all performance and safety requirements, including any applicable laws, regulations, codes and standards.

The illustrations, charts, sample programs and layout examples shown in this guide are intended solely for purposes of example. Since there are many variables and requirements associated with any particular installation, Allen-Bradley does not assume responsibility or liability (to include intellectual property liability) for actual use based upon the examples shown in this publication.

Allen-Bradley publication SGI-1.1, *Safety Guidelines for the Application, Installation and Maintenance of Solid-State Control* (available from your local Allen-Bradley office), describes some important differences between solid-state equipment and electromechanical devices that should be taken into consideration when applying products such as those described in this publication.

Reproduction of the contents of this copyrighted publication, in whole or part, without written permission of Rockwell Automation, is prohibited.

Throughout this manual we use notes to make you aware of safety considerations:

---

### ATTENTION



Identifies information about practices or circumstances that can lead to personal injury or death, property damage or economic loss

---

Attention statements help you to:

- identify a hazard
- avoid a hazard
- recognize the consequences

---

### IMPORTANT

Identifies information that is critical for successful application and understanding of the product.

---

## **European Communities (EC) Directive Compliance**

If this product has the CE mark it is approved for installation within the European Union and EEA regions. It has been designed and tested to meet the following directives.

### **EMC Directive**

This product is tested to meet the Council Directive 89/336/EC Electromagnetic Compatibility (EMC) by applying the following standards, in whole or in part, documented in a technical construction file:

- EN 50081-2 EMC — Generic Emission Standard, Part 2 — Industrial Environment
- EN 50082-2 EMC — Generic Immunity Standard, Part 2 — Industrial Environment

This product is intended for use in an industrial environment.

### **Low Voltage Directive**

This product is tested to meet Council Directive 73/23/EEC Low Voltage, by applying the safety requirements of EN 61131-2 Programmable Controllers, Part 2 - Equipment Requirements and Tests. For specific information required by EN 61131-2, see the appropriate sections in this publication, as well as the Allen-Bradley publication Industrial Automation Wiring and Grounding Guidelines For Noise Immunity, publication 1770-4.1.

This equipment is classified as open equipment and must be mounted in an enclosure during operation to provide safety protection.

## **Table of Contents**

### **Preface**

#### **Using This Manual**

Overview . . . . .	P-1
Contents of this Manual. . . . .	P-1
Intended Audience . . . . .	P-2
Conventions . . . . .	P-2
Rockwell Automation Support . . . . .	P-2
Local Product Support . . . . .	P-3
Technical Product Assistance . . . . .	P-3
On the Web . . . . .	P-3

### **Chapter 1**

#### **Module Overview**

Chapter Objectives . . . . .	1-1
Stepper Controller. . . . .	1-1
Operating Modes . . . . .	1-2
Configuration Mode . . . . .	1-2
Command Mode Operation . . . . .	1-3
Diagnostic Mode. . . . .	1-3
LED Indicator Diagnostics . . . . .	1-4
Input/Output Terminals. . . . .	1-5
Terminal Block Release Screws . . . . .	1-5

### **Chapter 2**

#### **Installation and Wiring**

Chapter Objectives . . . . .	2-1
General Precautions . . . . .	2-1
Installation . . . . .	2-1
Wiring . . . . .	2-2
Starting and Stopping the Module . . . . .	2-2
Wiring for a Differential Interface. . . . .	2-2
Wiring to Optocoupler Interface . . . . .	2-3
Wiring to Optocoupler Interface (Continued) . . . . .	2-5
Wiring Information for TTL Interface . . . . .	2-5
Typical Input Circuitry. . . . .	2-6
Typical Encoder Timing Diagram. . . . .	2-7
Encoder Feedback Connections . . . . .	2-8

---

<b>Chapter 3</b>	<b>Start Up and Troubleshooting</b>	
	Chapter Objectives . . . . .	3-1
	System Start Up. . . . .	3-1
	Normal Operation. . . . .	3-1
	Troubleshooting . . . . .	3-1
	Safety Precautions. . . . .	3-3
	Removing the Module . . . . .	3-3
<b>Chapter 4</b>	<b>Module Operation</b>	
	Chapter Objectives . . . . .	4-1
	Module Overview . . . . .	4-1
	Operating Modes . . . . .	4-1
	Configuration. . . . .	4-1
	Command . . . . .	4-2
	Operation Using the Pulse and Direction Outputs . . . . .	4-2
	Fixed Speed Operation . . . . .	4-2
	Origin (Home) Search Sequence of Operation. . . . .	4-3
	Resetting the Current Absolute Position. . . . .	4-3
<b>Chapter 5</b>	<b>Configuration and Programming</b>	
	Chapter Objectives . . . . .	5-1
	Programming Conventions . . . . .	5-1
	Configuration and Status Bits. . . . .	5-1
	Program Scan . . . . .	5-1
	SLC Processor Configuration . . . . .	5-1
	Processor configuration using APS . . . . .	5-2
	Processor configuration using HHT (Catalog 1747-PT1). . . . .	5-2
	Module Configuration . . . . .	5-3
	General Information. . . . .	5-3
	Configuration Error . . . . .	5-3
	Configuration mode output image table . . . . .	5-3
	Configuration mode input image table . . . . .	5-6
	Invalid Configurations . . . . .	5-6
	Programming Command Mode . . . . .	5-8
	Output Words – SLC Processor to Stepper Controller. . . . .	5-8
	<b>Output Command Word 0 Bit Definition . . . . .</b>	<b>5-8</b>
	<b>Command Mode Output Words. . . . .</b>	<b>5-8</b>
	Output Command Bits for Word 0 . . . . .	5-10
	Absolute/relative move commands . . . . .	5-11
	Homing Routines . . . . .	5-14
	Home to Limit Switch. . . . .	5-14
	Home to Proximity Limit Switch and Home Limit Switch . . . . .	5-14

Home to Proximity Limit Switch and Marker . . . . .	5-14
Programming Simple Moves . . . . .	5-16
General Information. . . . .	5-16
Data File Structures . . . . .	5-16
Using the N Files for Motion Commands. . . . .	5-17
Quadrature Encoder Input . . . . .	5-17
Use of Direct Inputs. . . . .	5-17
Programming Blended Moves . . . . .	5-18
General Information. . . . .	5-18
Blend move programming routine . . . . .	5-19
Module Status Inputs. . . . .	5-22
Input Word 0. . . . .	5-22
Input Word 1. . . . .	5-24
Input Words 2 and 3 . . . . .	5-25
Input Words 4 and 5 . . . . .	5-25
Diagnostics Feedback Test. . . . .	5-25
Configuration Data for Loop Back Diagnostic Test. . . . .	5-26
Ladder Instructions for Loop Back Diagnostics Test. . . . .	5-26
Command Mode Input Words . . . . .	5-28

## Chapter 6

### Application Examples

Chapter Objectives . . . . .	6-1
Data table used for the program listing for Sample Module Check Procedure . . . . .	6-1
Program Listing for Sample Module Check Procedure . . . . .	6-1
Entering Negative Position Data . . . . .	6-4
Converter Example . . . . .	6-5

## Appendix A

### Specifications

Industry Standards . . . . .	A-1
General Specifications . . . . .	A-1
LED Indicators . . . . .	A-1
Power Requirements . . . . .	A-2
System Limitations . . . . .	A-2
Discrete Inputs . . . . .	A-2
Discrete Outputs . . . . .	A-2
Input/Output Terminals . . . . .	A-3
Environmental Operating Conditions . . . . .	A-3
Storage Temperature . . . . .	A-3
Feedback Circuitry . . . . .	A-3
Program Storage Requirements . . . . .	A-3
Processor Compatibility . . . . .	A-3

## **Appendix B**

## **Input/Output Quick Reference**

## **Index**

## Using This Manual

### Overview

Read this chapter to familiarize yourself with the rest of the manual. It provides information concerning the:

- contents of this manual
- intended audience
- conventions used
- hazards of injury or equipment damage

### Contents of this Manual

This manual provides specific information relevant to the Stepper Controller Module, Catalog Number 1746–HSTP1. The following table identifies the chapters, titles and contents.

Chapter	Title	Contents
Preface	Using This Manual	An overview of this manual
1	Module Overview	Module Overview, its operation and hardware features
2	Installation and Wiring	Interconnection diagrams for various hardware interfaces for communication with the Stepper Controller.
3	Start Up and Troubleshooting	Start up, normal states of LED indicators, troubleshooting and error handling information.
4	Module Operation	Describes interface selection, the Module's use of inputs and outputs, and operating modes
5	Configuration and Programming/Status	Provides the steps necessary to configure the SLC™ Processor and Stepper Controller
6	Application Examples	Illustrated sequencer, configuration and command data files.
Appendix A	Specifications	Temperature, humidity, input output, voltage, timing and cabling information.
Appendix B	Input/Output Quick Reference	A quick reference for the Input/Output config and command bits and words.



## Intended Audience

This manual is designed for the qualified first time user who has a working knowledge of SLC 500™ products. If necessary, obtain the proper training before using the Stepper Controller.

## Conventions

The following terms are used throughout this manual:

**Input file** – refers to the Module's Input Data file. This file is updated during the SLC Processor input scan

**Output file** – refers to the Module's Output Data file. This file is updated during the SLC Processor output scan.

**Module** – refers to the Stepper Controller, catalog number 1746-HSTP1

**Physical outputs** – refers to actual outputs on the Stepper Controller

**SLC Processor** – refers to an SLC 500 family processor

**Stepper Translator** – refers to the interface between the Stepper Controller and the stepper motor that converts pulse train outputs into power signals used to run the motor.

**Position Loop** – refers to the ability of a controller to accurately position a mechanism to a precise point based on a dynamic comparison of command data and feedback from a sensor.

**Engineering Units** – refer to decimal fractions of units of measurement; e.g., inches, millimeters and degrees.

**CW** – refers to rotation or movement in a clockwise direction.

**CCW** – refers to rotation or movement in a counter-clockwise direction.

## Rockwell Automation Support

Rockwell Automation offers support services worldwide, with over 75 sales/support offices, 512 authorized distributors, and 260 authorized systems integrators located throughout the United States. In addition, Rockwell Automation representatives are located in every major country in the world.

## **Local Product Support**

Contact your local Rockwell Automation representative for:

- sales and order support
- product technical training
- warranty support
- support service agreements

## **Technical Product Assistance**

If you need to contact Rockwell Automation for technical assistance, please review the information in this manual. If the problem persists, call your local Rockwell Automation representative.

The Rockwell Automation Technical Support number is:

**1-603-443-5419**

## **On the Web**

For information about Allen-Bradley, visit the following World Wide Web site:

**<http://www.ab.com/>**



## Module Overview

### Chapter Objectives

The Module overview will permit you to understand the basic functions of the Module and hardware requirements.

### Stepper Controller

The Module, catalog number 1746-HSTP1, is an SLC 500 family compatible device. It can be used with any SLC 500 Processor.

The Module is configured through the SLC 500 backplane and requires no switch settings. Motion can be programmed in either direction for over  $\pm 8,000,000$  counts of absolute position.

An optional incremental encoder may be used to verify the position reached by the axis. The Module does not automatically close a position loop in engineering units. The feedback hardware can accept frequencies of up to 250 kHz for use as either loop back diagnostics or differential incremental encoder feedback devices.

The Module can be programmed for either incremental or absolute moves, depending on the application.

The Module supports two differential outputs, to suit the type of Stepper Translator used, which provide the following control commands:

- CW or non-directional pulse output
- CCW or direction signal output

Discrete inputs are provided for:

- External Interrupt
- Home Limit Switch
- Home Proximity Input
- CW Travel Limit Switch Input
- CCW Travel Limit Switch Input
- Pulse Train Enable/Disable Input

Differential inputs are provided for:

- Encoder Channel A and A NOT
- Encoder Channel B and B NOT
- Encoder Marker Channel

**Figure 1.1 Stepper Module Overview**

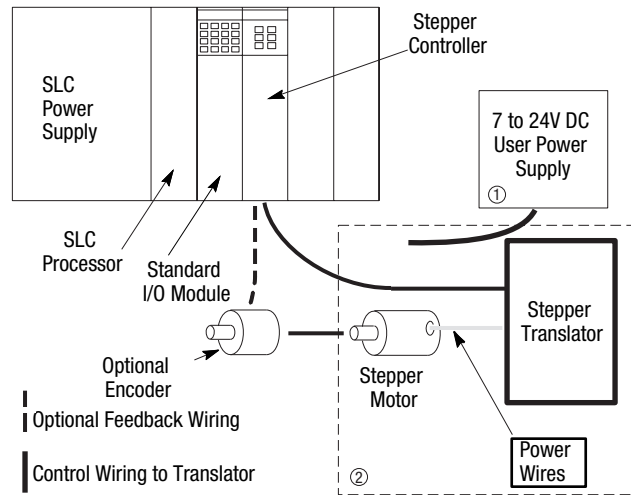

① The 24V may be obtained from the SLC Power Supply depending on application power requirements.  
 ② Motor and translator furnished by the customer.

## Operating Modes

The Module operates in three different modes: configuration, command, and diagnostic. The three operating modes are summarized below.

## Configuration Mode

The configuration mode is commanded by setting the mode flag (bit 15 in output word 0) to 1. In this mode, the Module is configured through the SLC Processor to perform specific operations that the user desires. The configuration mode defines the basic operation of the Module.

### **IMPORTANT**

The Module does not operate until it has been configured at least once.

The Module can be configured to:

- Determine which inputs are used.
- Determine the active level of inputs used.
- Set whether just the encoder marker or a prox limit switch and encoder marker combination is used for homing.
- Determine if a quadrature encoder will be used.
- Select whether the Module output is a pulse train with direction command or a CW pulse train and CCW pulse train.
- Select between configuration mode and command mode.

**NOTE:** Some output combinations are not valid. For example, using feedback diagnostics and quadrature encoder or using a marker pulse and a home limit switch. If any invalid combinations are sent, the configuration error input bit will be set.

## Command Mode Operation

All stepper motor operations are performed in command mode. This mode is entered by setting the mode flag (bit 15 in output word 0) to 0.

In command mode, the SLC Processor can issue commands and activate different operations or moves. The actions you can command are:

- Absolute Moves
- Relative Moves
- Hold Moves
- Resume Moves
- Immediate Stop Operations
- Homing Operations
- Jogging Operations
- Blend Moves
- Preset Operations
- Reset Errors

## Diagnostic Mode

Use the configuration mode to select the diagnostic mode of operation. Once selected, the diagnostic mode allows you to test your program and wiring by connecting the loop back wires at the translator. The purpose of loop back diagnostics is to test the system wiring for electrical noise. The number of pulses received at the feedback should equal the commanded number of pulses at the end of the move. If they are not equal, the system may be experiencing problems due to electrical noise.

## LED Indicator Diagnostics

There are five diagnostic LED indicators provided as shown below. Their purpose is to aid in identifying operational problems.

Figure 1.2 LED Indicators

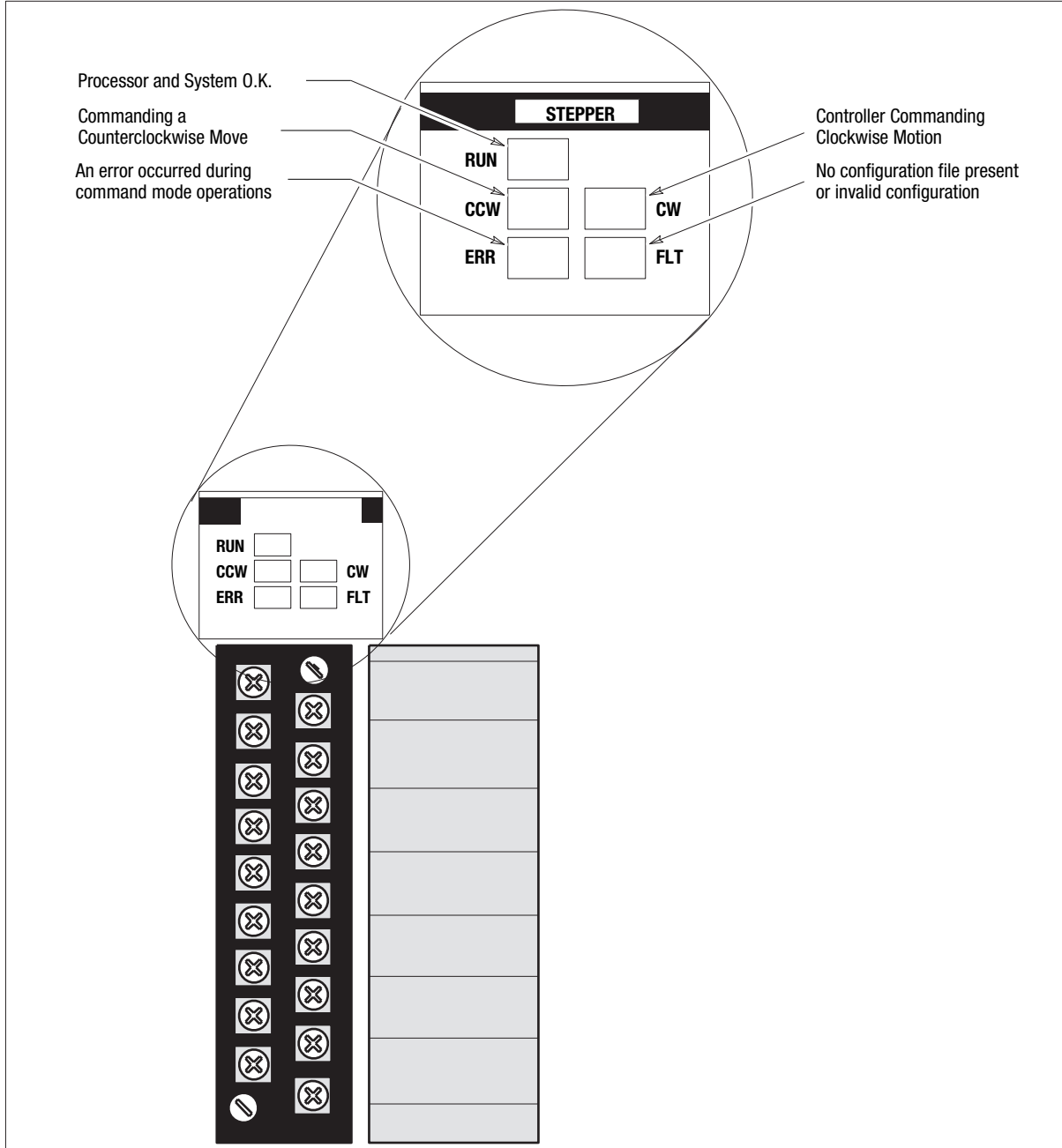

## Input/Output Terminals

These terminals supply power and inputs to the Module and outputs to attached devices. Each can accommodate two #14 gauge wires.

**Figure 1.3 Input/Output Terminals**

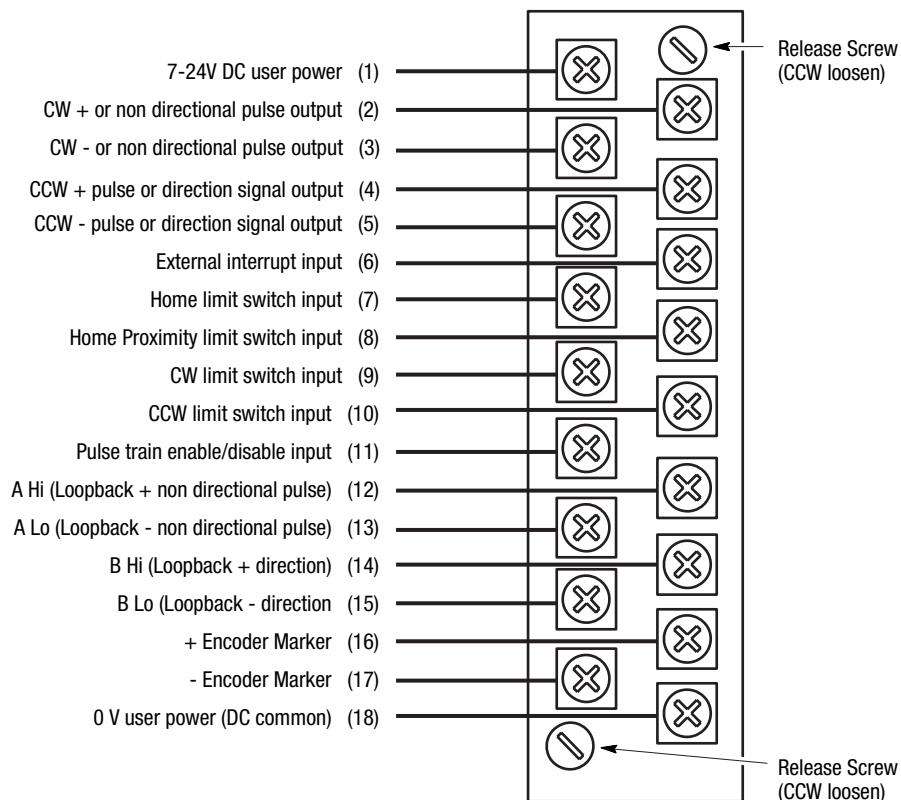

## Terminal Block Release Screws

These captive screws are attached to the terminal block. As the screws are loosened, the terminal block moves away from the Module. This feature facilitates replacement of the Module without rewiring.





## Installation and Wiring

### Chapter Objectives

This chapter provides information which permits you to properly unpack, install and wire the interfaces between the Module and the various Stepper Translators that can be used with the Module. Also covered are typical input circuitry (direct input and encoder input), and encoder timing information and encoder feedback connections.

### General Precautions

In addition to the precautions listed throughout this manual, the following statements which are general to the system must be read and understood.

---

**ATTENTION**

This drive contains ESD (Electrostatic Discharge) sensitive parts and assemblies. Static control precautions are required when installing, testing, servicing or repairing this assembly. Component damage may result if ESD static control procedures are not followed. If you are not familiar with static control procedures, reference A–B publication 8000–4.5.2, “*Guarding Against Electrostatic Damage*” or any other applicable ESD protection handbook.

An incorrectly applied or installed Module can result in component damage or a reduction in product life. Wiring or application errors, such as, undersizing the motor, incorrect or inadequate AC supply, or excessive ambient temperatures may result in malfunction of the system.

Only personnel familiar with the Module and associated machinery should plan or implement the installation, start-up and subsequent maintenance of the system. Failure to comply may result in personal injury and/or equipment damage.

---

### Installation

1. Install the Module in the designated slot in your SLC controller rack. Refer to your SLC controller user manual.
2. Wire the input and output devices as instructed in the following information.

## Wiring

Refer to the following information on typical interface requirements before beginning this procedure.

---

**ATTENTION**

The following information is merely a guide for proper installation. The Allen-Bradley Company cannot assume responsibility for the compliance or the noncompliance to any code, national, local or otherwise for the proper installation of this drive or associated equipment. A hazard of personal injury and/or equipment damage exists if codes are ignored during installation.

---

To meet the installation requirements of Underwriters Laboratories Inc. standard UL 508 for industrial control equipment, follow the guidelines below.

- Use 60/75° C copper wire when wiring the 1746-HSTP1 system.
- Tighten the terminals on the 1746-HSTP1 to 5 lb/in.
- Use Class 1 or Class 2 wiring for the terminals on the 1746-HSTP1 system.

For more information, refer to standard UL 508 or the National Electric Code.

## Starting and Stopping the Module

---

**ATTENTION**

The Module Enable/Disable control circuitry includes solid-state components. If hazards due to accidental contact with moving machinery or unintentional flow of liquid, gas or solids exist, an additional hardwired stop circuit is required.

---

## Wiring for a Differential Interface

Several manufacturers of Stepper Translators provide differential inputs. If your Stepper Translator can accept differential line driver outputs, follow the interconnection diagram below to connect the Stepper Controller to the translator.

**Figure 2.1 Differential Input**

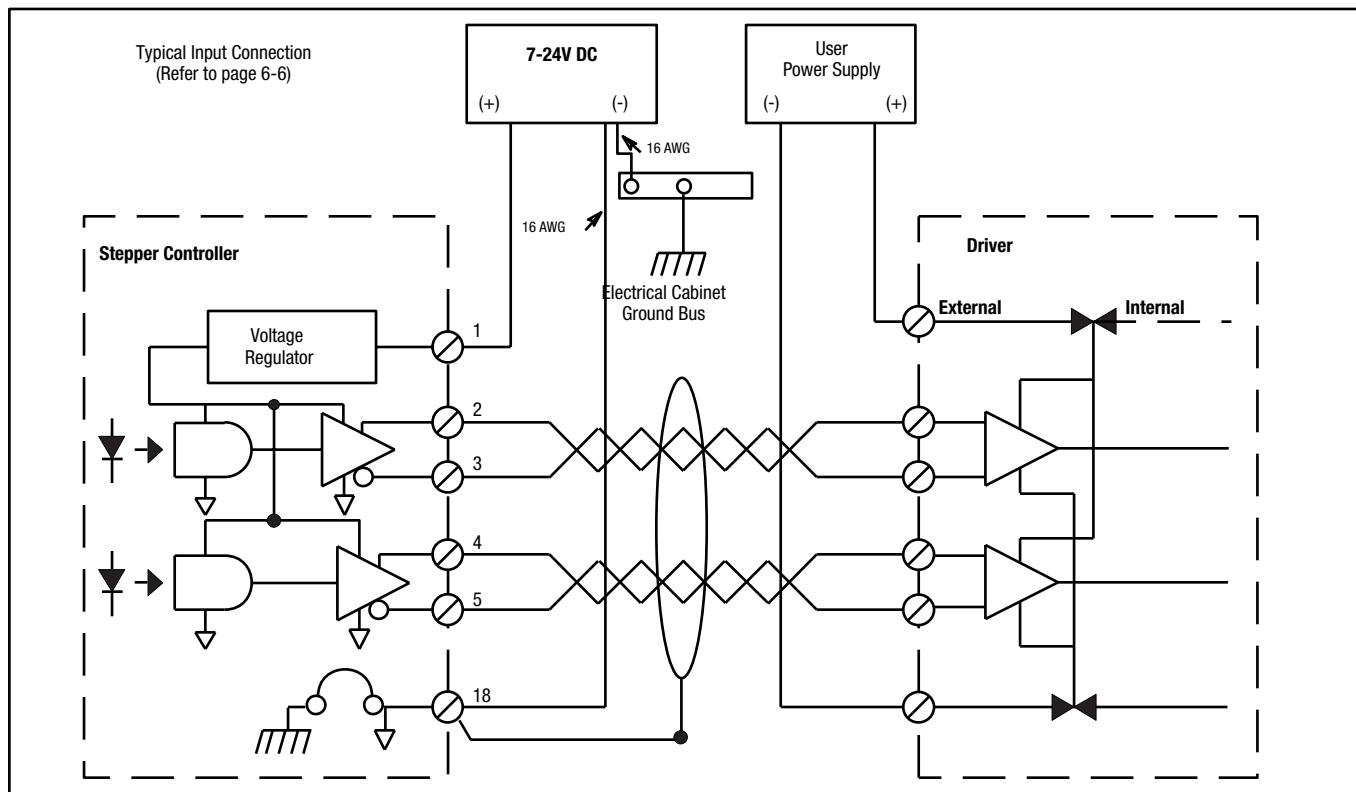

## Wiring to Optocoupler Interface

The following diagrams show the circuitry used to interface the Module to a Stepper Translator through two different optocoupler devices. The first diagram shows an optocoupler designed for a common power supply connection. The second diagram shows an individually isolated optocoupler. It is your responsibility to determine which type is used in your specific application, and to ensure that connections are properly made.

Figure 2.2 Optocoupler Input Common Supply

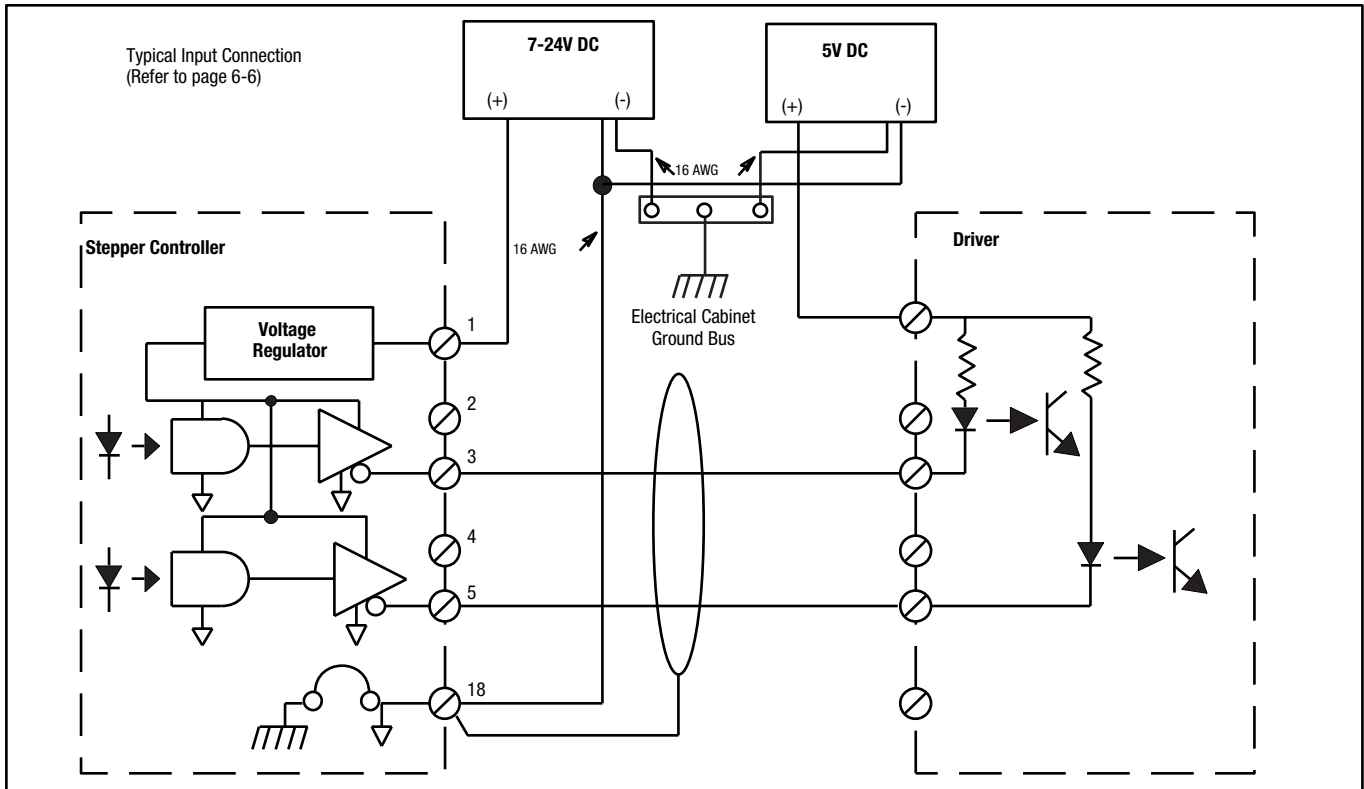

## Wiring to Optocoupler Interface *(Continued)*

Figure 2.3 Individually Isolated Optocoupler

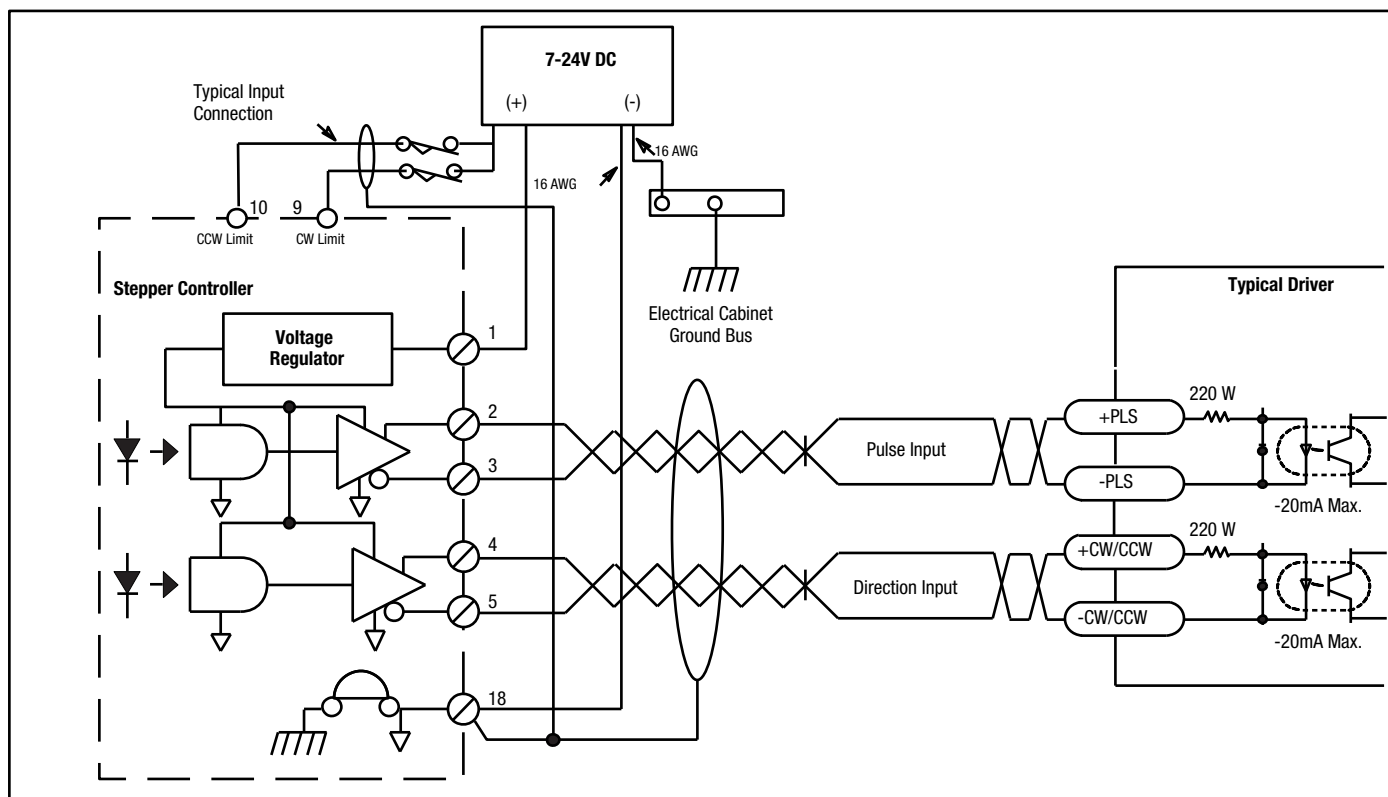

## Wiring Information for TTL Interface

The following wiring diagram shows the connections between the Module and a Stepper Translator that requires a TTL Interface. The 5-volt supply to the TTL interface can be either internal to the translator itself or a separate power supply selected by the user. This design is probably the most sensitive to noise due to the single ended, high-speed nature of the TTL device. For this reason, it should be used only where the Stepper Translator is close to the Module, that is, no more than five cable feet, in an enclosure that is well shielded from EMI noise when the enclosure doors are closed.

Figure 2.4 TTL Interface

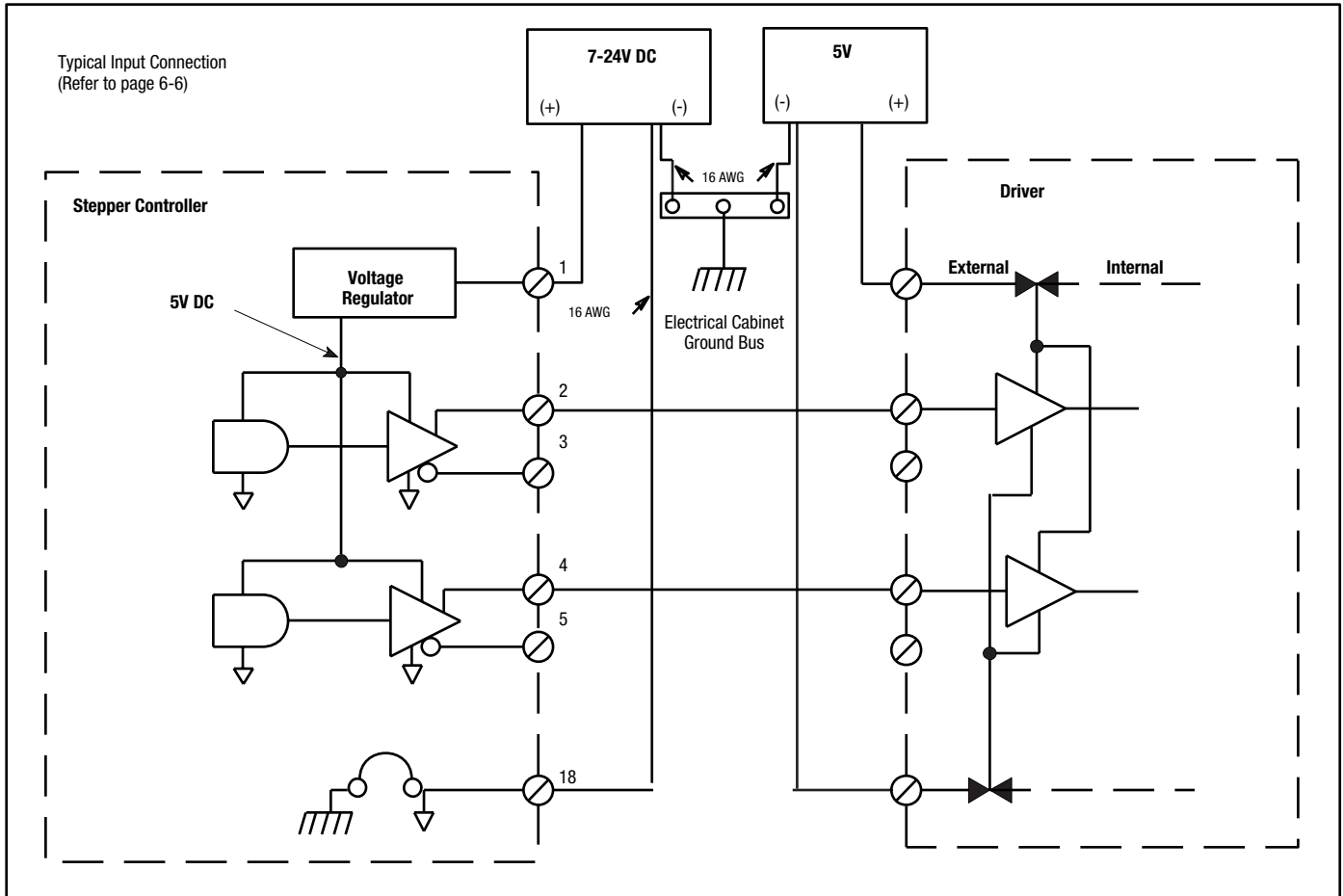

## Typical Input Circuitry

Two basic circuits are used for inputs to the Module. One type is the direct input circuit for home limit switches, overtravel limits, and interrupt devices. The second type is for encoder inputs. Both circuits are shown below.

Figure 2.5 Direct input equivalent circuit

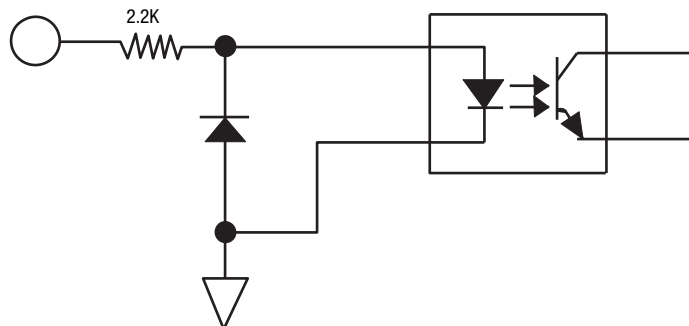
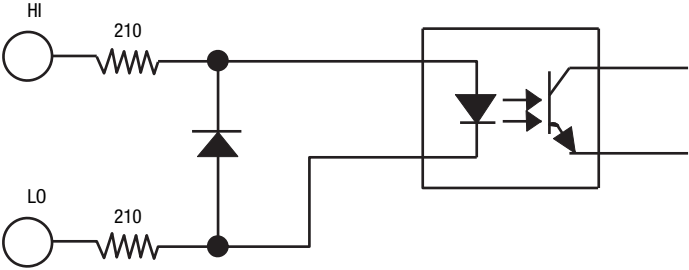
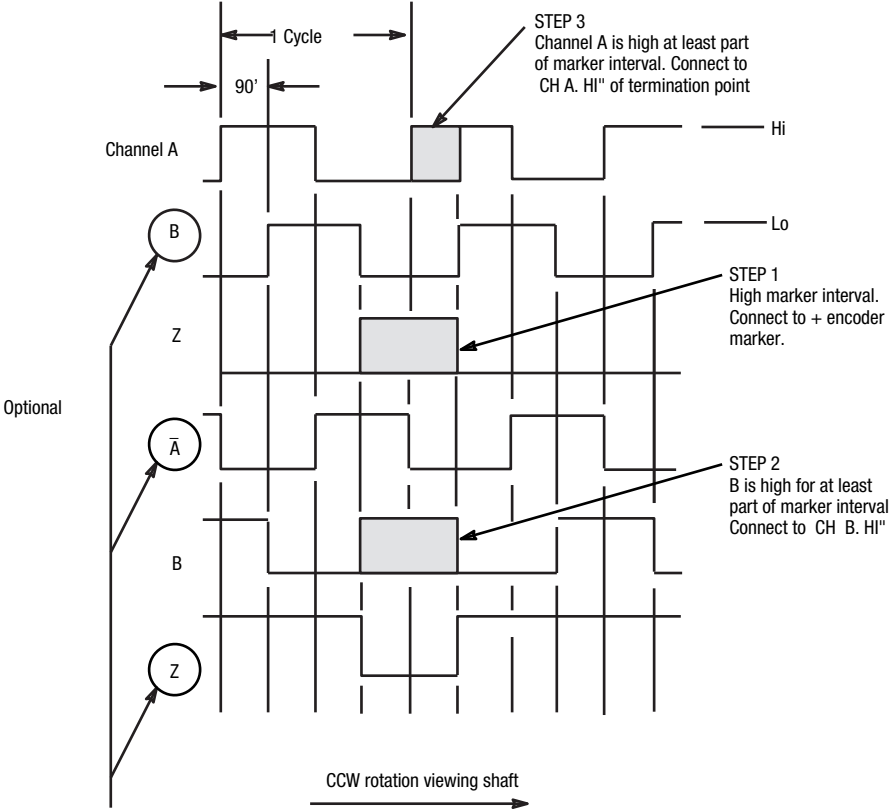

Figure 2.6 Encoder input equivalent circuit



### Typical Encoder Timing Diagram

A typical encoder timing diagram is shown below. For actual connections, consult your encoder manufacturer's timing diagram. For all encoder types, if the direction (phasing) of the feedback is backwards, correct this condition by reversing the channel A and channel B connections.



Wire CH B, CH A, and CH Z to CH B LO, CH A LO, and CH Z LO, respectively on the terminal block.



## Encoder Feedback Connections

The following two diagrams illustrate encoder connections to the Module inputs for both 5-volt and 15-volt encoder power supplies. The "notes" included with each diagram provide specifics on wiring.

**Figure 2.7 5-volt encoder feedback connections**

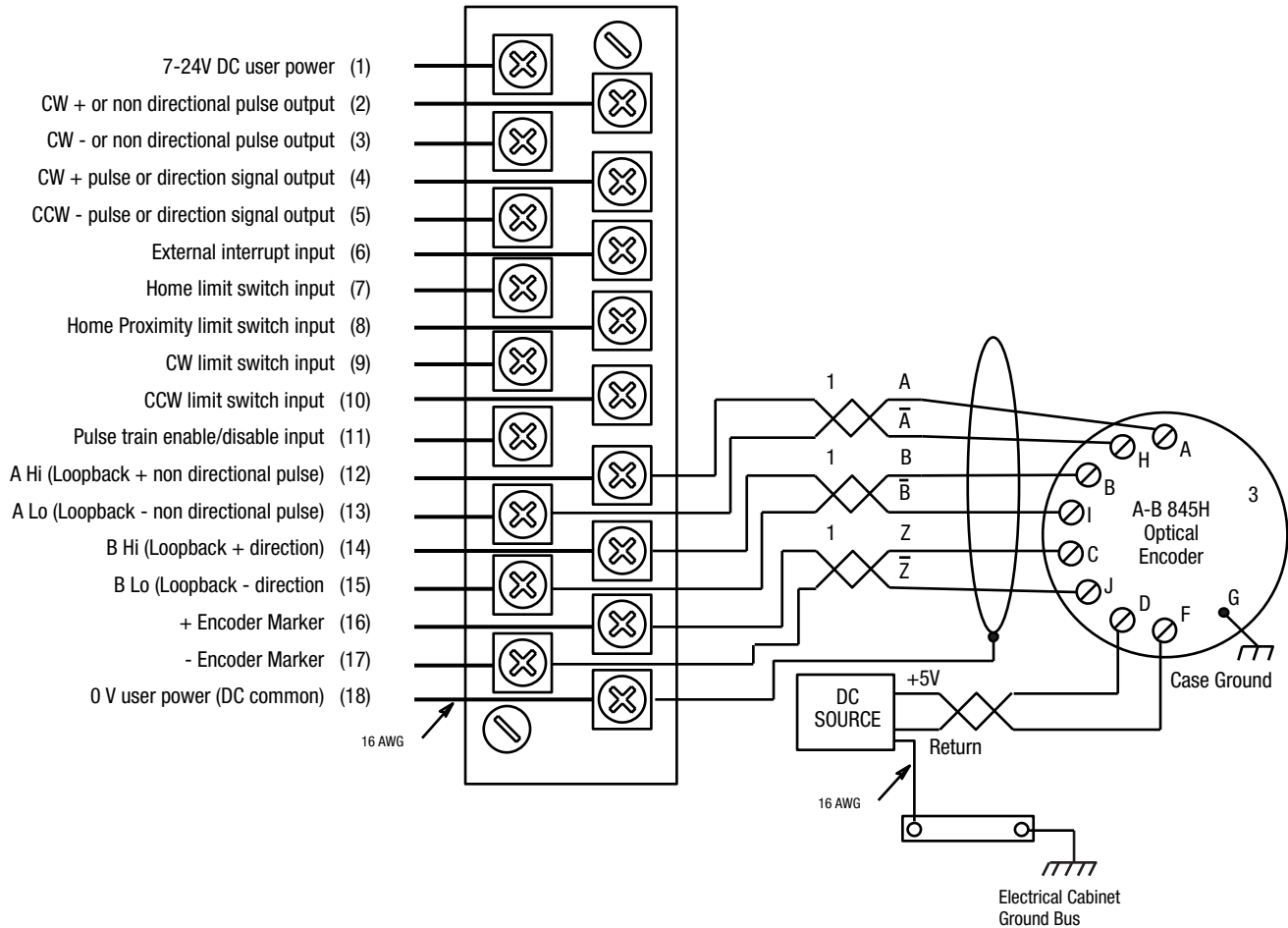

### Notes:

1. Use 3-pair, #22 gauge individually twisted and shielded pair, Belden 9504 or equivalent.
2. Use 1-pair, #18 gauge twisted and shielded cable.
3. Encoders must have +5V compatible differential line drive outputs on channels A, B, and Z. (DS8830, or equivalent.) (A-B 845H)
4. +5V from encoder power source – connect encoder return to 0V user power (DC common) at the power supply sources.

Figure 2.8 15-volt encoder feedback connections

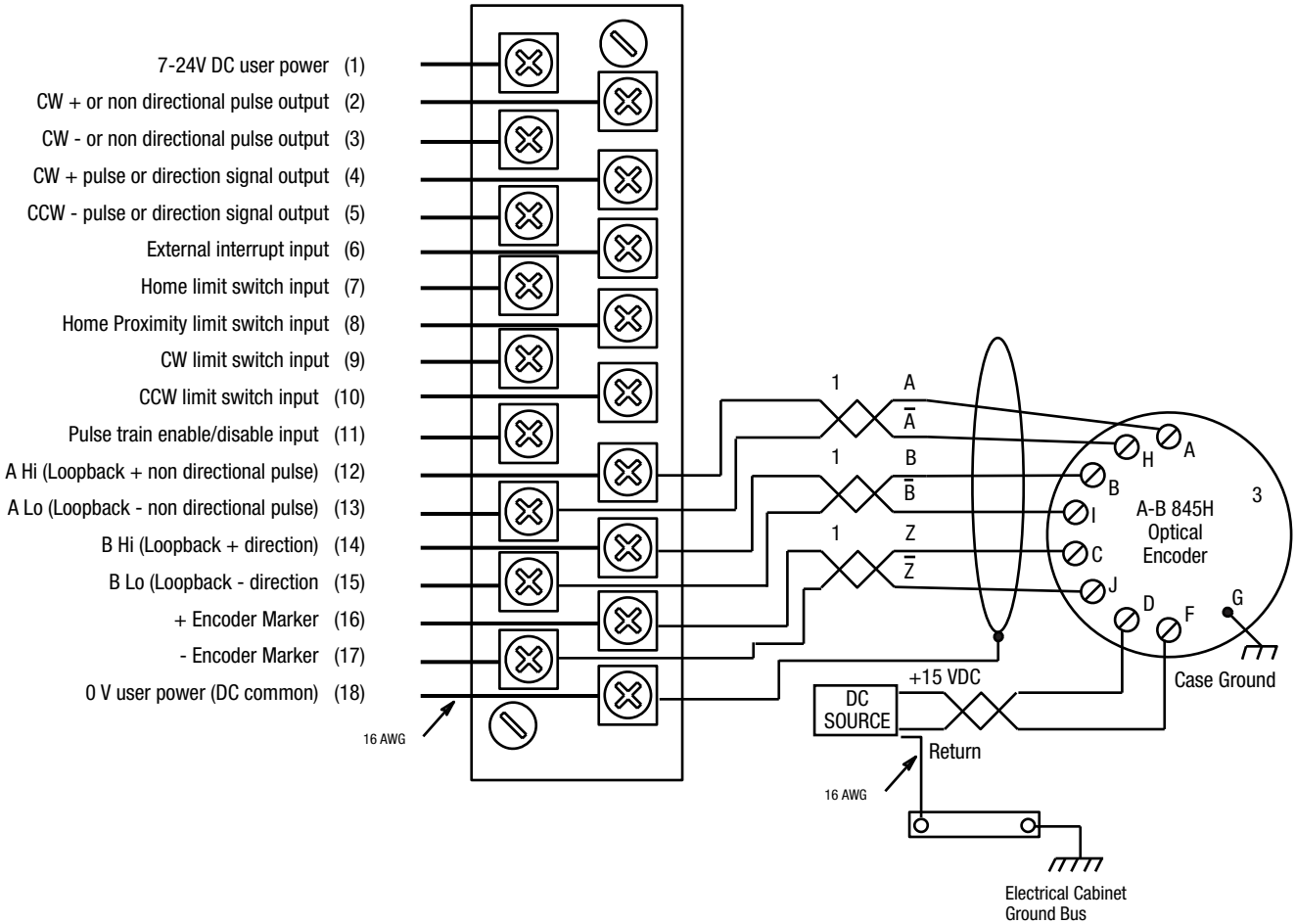

**Notes:**

1. Use 3-pair, #22 gauge individually twisted and shielded pair, Belden 9504 or equivalent.
2. Use 1-pair, #18 gauge twisted and shielded cable.
3. Encoders must have +5V compatible differential line drive outputs on channels A, B, and Z. (DS8830, or equivalent.) (A-B 845H)
4. +15V from encoder power source – connect encoder return to 0V user power (DC common) at the power supply sources.



## **Start Up and Troubleshooting**

### **Chapter Objectives**

This chapter contains information that will help you perform the following start up, troubleshooting, and error handling procedures.

### **System Start Up**

The following instructions apply to initial start up of a Module.

- 1.** Apply power to the SLC system and to the attached input and output devices.
- 2.** Configure the SLC Processor and the Module as instructed in Chapter 4 of this manual.
- 3.** Upon successful completion of the configuration steps, the SLC Processor will switch the Module to the command mode of operation.

### **Normal Operation**

There are no provisions for local control of the Module. Module status is monitored by the five LED indicators located on the front face of the Module. Refer to Chapter 2 of this manual for further information on these LED indicators.

### **Troubleshooting**

The ERR (error) and FLT (fault) LED indicators on the Module face serve as diagnostic tools for use in general troubleshooting.

If an operation error occurs during command mode operation, the ERR LED will light.

If there is no configuration file resident in the Module, or if the resident configuration file is invalid in any way, the FLT LED will light.

More detailed troubleshooting information is provided in the following list:

Problem	Resolution
No green RUN LED	Either a major Module malfunction or lack of power from the backplane is indicated. Check for power from the backplane first; if power is present, the Module must be replaced.
Red FLT LED is lit	Module is improperly configured. Refer to the topic, "Configuration Mode" in Chapter 4 of this manual for additional information.
Red ERR LED is lit	This means that invalid data has been copied into one of the command mode output words (position, velocity, acceleration and/or deceleration). The invalid data must first be corrected in the appropriate "N" file of the SLC Processor, and the error then reset. The error is reset by resetting bit 15 of the configuration mode output word 0 to a logic "10".
Module completes one move, and stops	The Module is not "seeing" the 0 to 1 transition required for each new move (either absolute or relative). To avoid this condition, it is recommended, when programming, that you unlatch bits 0 and/or 1 each time a move is in progress. Note that this will not cause a problem when toggling between absolute and relative moves.
Module Ready bit goes false during operation	This could be the result of a poorly seated Module. Check that the Module is properly inserted in its slot. If the Module appears to be properly seated, request help from Allen-Bradley Technical Support. Be sure to provide a copy of the program involved, and as many other details as you can about the circumstances that trigger the fault to assist in the solution of the problem.
Limit switch inputs	<p>Limit switch inputs are detected by and their states are reported by the Module software. If they are not reading properly:</p> <ol style="list-style-type: none"> <li>1) check input signal levels</li> <li>2) check state setting in configuration</li> <li>3) check wiring.</li> </ol> <p>Limit switch data can be read by accessing configuration mode input word 1. Incorrect limit switch states can be altered by setting the respective bits in configuration mode output word 1 (refer to the "Configuration Mode" topic in Chapter 4 of this manual).</p>
Encoder is not reading	This condition can be due to any of the following errors: improper voltage level is being provided to the encoder by the encoder power supply; improper signal level from the encoder, encoder miswired; or, the Module has not been configured to accept encoder input ( <b>IMPORTANT: The Module operates differently when loop back diagnostics are active; this mode uses a pulse train and direction bit versus quadrature encoder pulses</b> ). Correct the encoder power supply voltage level or reconfigure the Module as applicable.

## Safety Precautions

---

**ATTENTION**

Severe injury or death can result from electrical shock, burn, or unintended actuation of controlled equipment. Hazardous voltages may exist in the control cabinet even with the circuit breaker in the off position. Recommended practice is to disconnect and lock out control equipment from power sources, and discharge stored energy in capacitors, if present. If it is necessary to work in the vicinity of energized equipment, the safety related work practices of NFPA 70E, Electrical Safety Requirements for Employee Workplaces, must be followed.

DO NOT work alone on energized equipment.

---

## Removing the Module

Removal of the Module is facilitated by captive screws on the Terminal Block (refer to Chapter 2).



## Module Operation

### Chapter Objectives

The information in this chapter will give you a basic understanding of frequency outputs and pulse train configuration which must be considered in the application of the Module.

### Module Overview

The Module is an SLC family compatible Module. It is designed for use with an SLC 500™, SLC 5/01™, SLC 5/02™, SLC 5/03™, SLC 5/04™, or SLC 5/05™ Processor. The motion profile execution is independent of the scan time of the SLC Processor once it is initiated. Blended motion allows for complicated move profiles consisting of two to 16 segments. The blended move profiles are stored in the Module's internal memory as a series of absolute moves. Since the sequence of moves is stored in the internal memory of the Module, it can be executed more than once. Other move or homing operations may be performed between blended move profiles.

The Module is capable of controlling absolute position over a range of  $\pm 8,388,607$  pulses with a programmable velocity of 1 to 250,000 pulses per second and acceleration/deceleration rates between 1 and 2,000 pulses per millisecond per second. The Module is able to perform an origin search (also called homing) and to automatically reset the absolute position to zero upon detection of an encoder marker when an origin search function is requested by the SLC Processor.

### Operating Modes

The three operating modes of the Stepper Controller are: configuration mode, command mode, and diagnostic mode.

#### Configuration

The Configuration mode permits the selection of the proper setup configuration to match the Stepper Translator without setting any switches and without special software. Until the configuration mode has been properly set, the Stepper Controller will not operate. Enabling loopback diagnostics is done using the configuration mode. In the diagnostic mode, a check is made for noise in the interconnecting wiring, as well as a check of the program itself.



## Command

The Command mode directs all stepper motor operations, through the Stepper Translator. There are translators which require a pulse train and direction to operate. Other translators require a CW (positive direction) pulse train and a CCW (negative direction) pulse train. The CW and CCW designations refer to directions of stepper motor rotation. The Stepper Controller can be configured for either type of translator.

When operating in either the Configuration or the Command mode, Module status is reported to the SLC Controller.

## Operation Using the Pulse and Direction Outputs

If the Stepper Translator requires pulse and direction outputs, configuration output word 0, bit 10 has to be set to a logic "1", since the default state of the Stepper Controller is set up for CW and CCW pulses (logic "0", on bit 10). Assuming the Module is inserted in slot 0, the bit address is 0:0.0/10.

The pulse train and direction signal are illustrated just below the unconditional rung for clarity. The programmed speed value controls the frequency of the pulse train and the sign of the destination value controls the direction output of the Stepper Controller. An alternate configuration method is to ensure bit 10 of word 0 is true when moving or copying a data file to word 0 of the output address.

**Figure 4.1 Pulse and Direction Outputs**

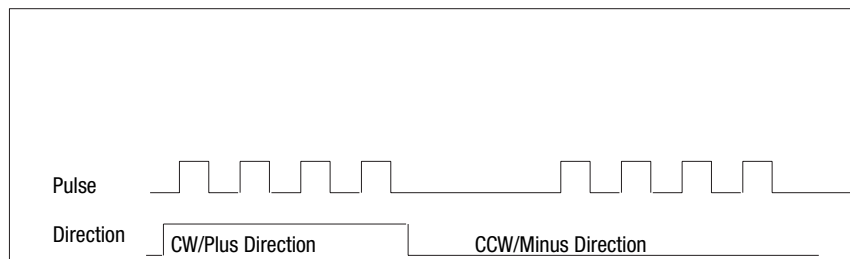

## Fixed Speed Operation

Operation at fixed speed will cause the pulse and direction to accelerate at the programmed acceleration rate and reach the final

programmed velocity data. Use the Jog+ or Jog- to initiate and stop the motion.

---

**IMPORTANT**

Turning the appropriate bit on will cause the axis to move. Turning it off causes the axis to decelerate and stop.

---

### **Origin (Home) Search Sequence of Operation**

Information on this subject is contained in Chapter 4 of this manual, within the topic, “Find Home +/(CW), Find Home –/(CCW)”. Note that the way in which a search is carried out if a home proximity limit switch is present is different from the sequence when a home proximity limit switch is not present. The differences are detailed in Chapter 4.

### **Resetting the Current Absolute Position**

In the event that an “Invalid Position” (input word 0 bit 10 is false), occurs while in command mode, and no position error actually exists, a command to “preset position” assigns a predetermined position value as the absolute position. This establishes the current absolute position of the axis, and allows subsequent absolute moves to take place. A typical ladder diagram showing the command to “preset position” is provided in rung 2:3 of the “Program Listing for Sample Move” in Chapter 5 of this manual.



---

# Configuration and Programming

## Chapter Objectives

This chapter provides information to help you configure both the SLC Processor and the Module. This chapter also contains instructions for correctly programming the Module for the command mode of operation.

## Programming Conventions

Since the SLC Processor does not support numbers as large as 8,000,000, the number must be entered as two distinct integer values that can be programmed within the capabilities of the SLC Processor. The value is equated to two 16 bit integer values that provide a coarse and fine resolution. The least significant word allows for a range of 0 to 999 counts. The most significant word (MSW) provides thousands of counts. For example, to output 8,000,000 counts, set the most significant word to 8,000 and the least significant word (LSW) to 0.

## Configuration and Status Bits

Configuration, status and command information is transferred between the SLC Processor and the Stepper Controller with each scan of the SLC ladder. The configuration and status bits are boolean values that can be assigned or read easily by the SLC ladder program. Word 0 and word 1 of the address assigned to the Stepper Controller are allocated to status and command words. Status bits are defined in Module Status, later in this chapter. Detailed use of the configuration bits is described in Configuration Mode, later in this chapter.

## Program Scan

The Module provides new information to the SLC backplane every 250 microseconds.

## SLC Processor Configuration

The SLC Processor must be configured to accept the Stepper Controller as an I/O device. This can be done with either the Hand Held Terminal (HHT) or APS software running on a personal computer. Although the configuration steps are similar using either method, they are not identical. The two methods are described separately, below.

## Processor configuration using APS

1. Locate an open slot in your chassis. The Module can be used with any SLC Processor.
2. Assign your SLC Processor, if not done previously:
  - a. Using APS, press F3 (Offline PRG/DOC), F1 (PROCSSR FUNCTNS) and F1 (CHANGE PROCSSR) again to assign your processor and Module.
  - b. Press F2 to select a processor or F5 to assign a Module.
3. Assign the Module to an open slot:
  - a. Using APS, highlight an open slot.
  - b. Press F5 (MODIFY SLOT). Highlight last entry entitled OTHER. Press ENTER.
4. Enter Module ID Code 3512 (the ID of the Stepper Controller).
5. Eight input and eight output words are automatically created by the ID code.

Use the data monitor function to enter parameters into the bit (#B) or Integer (#N) file. Use F1 to change between binary and decimal.

## Processor configuration using HHT (Catalog 1747-PT1)

1. Locate an open slot in your chassis. The Module can be used with any SLC Processor.
2. Assign your SLC Processor, if not done previously.
3. Assign the Module to an open slot:
  - a. Using an HHT, press F3 (EDT\_I/O).
  - b. Select an open slot with the cursor and press: F2 (MOD\_SLT), F3 (OTHER).
4. Enter Module ID code 3512 (the ID of the Stepper Controller).
5. Eight input and eight output words are automatically created by the ID code.

---

Use the EDT-DAT function to enter parameters into your bit or integer files.

---

**IMPORTANT**

The HHT has a default radix of binary for the bit file (#B) and integer for the integer file (#N). Radices cannot be changed.

---

## Module Configuration

### General Information

The Module must be properly configured before any operations may begin. The Module enters the configuration mode on power up, or upon setting the configuration output word 0 mode bit (15) to 1. When configuration mode is set, the Module stops command mode operations (if applicable), sets the configuration mode flag in the configuration mode input table (bit 15), and waits for the configuration file to be transferred over the backplane from the SLC Processor.

### Configuration Error

If there is no configuration file present, or if it is invalid for any reason, the configuration error input bit (13) in configuration mode input word 0 is set. If the new configuration file is acceptable, it is mirrored in the input image table and the error input bit (13) is set to false (0).

---

**IMPORTANT**

The Module is ready to operate when the "Module OK" bit (14) in configuration input word 0 is 1.

---

### Configuration mode output image table

In the Configuration Mode, the proper setup configuration is selected to match the Module to the Stepper Translator. Module parameters are defined by the configuration file which is resident in the SLC Processor's memory.

Configuration mode is entered by setting bit 15 of output word 0. At the same time that bit 15 is set, the required configuration data must be transferred to the Module. No operating commands can be acted

upon by the Module until a valid configuration is received. The configuration file has the following format.

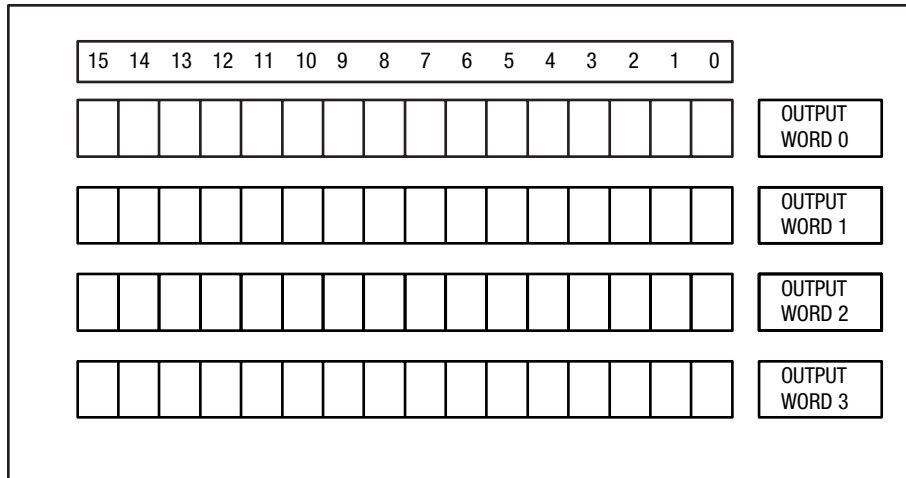

**Output word 0:** defines the user's configuration; that is, what types of inputs are present.

**IMPORTANT**

To guard against a configuration error, certain bits in output word 0 must be set. Either bit 0 or bit 1 (or both) must be set; and either bit 4 or bit 4 and bit 5 must be set. This is true whether or not the indicated limit switch is present in the system. Also, there are certain output combinations that obviously are not valid (e.g., setting both bit 8 and bit 9). Using an invalid output combination results in a configuration error being generated.

- bit 0            when a CW limit switch is used
- bit 1            set when a CCW limit switch is used
- bit 2            set when the pulse train enable/disable input is used
- bit 3            set when an external interrupt is used
- bit 4            set when a home limit switch input is used
- bit 5            set when a home limit proximity limit switch is used
- bits 6 and 7   not used
- bit 8            set when a quadrature encoder is used
- bit 9            set when diagnostics feedback is used

bit 10	1 when output pulse type is pulse train and direction 0 when output pulse type is CW pulse train and CCW pulse train
bit 11	not used
bit 12	0 for limit switch home operations 1 for marker pulse home operations
bit 13 and 14	not used
bit 15	1 for configuration mode 0 for command mode

**Output word 1:** Defines the active levels of the inputs. The bits are set for high true (logic 1 for input of 7 VDC or higher), or normally open (NO); or reset for low true (0 V = logic 1), or normally closed (NC). Note that the active levels of the inputs are taken into account only when the corresponding input is present in output word 0.

bit 0	determines the active level of the CW limit switch
bit 1	determines the active level of the CCW limit switch
bit 2	determines the active level of the pulse train disable input
bit 3	determines the active level of the external interrupt input
bit 4	determines the active level of the home limit switch input
bit 5	determines the active level of the home proximity limit switch input
bits 6 – 15	not used

**Output words 2 and 3:** Defines the starting (or base) speed of the Module. The starting speed is the minimum speed at which every move begins and ends. The starting speed must be higher than the speed at which low frequency resonance occurs in the stepper motor, and is dependent on motor characteristics. The format for starting speed data is:

Word 2	Starting speed most significant word (MSW)
Word 3	Starting speed least significant word (LSW)



## Configuration mode input image table

The data format of the input image table when the Module is in the configuration mode is:

Input word 0:

bits 0-5, 8-10 identical to like numbered bits in output table

bits 6, 7 and 11 not used

bit 13 configuration error: 1 = error; 0 = no error

bit 14 Module OK: 1 = Module operational,  
0 = fatal error encountered

bit 15 1 when in configuration mode  
0 when in command mode

Input word 1:

bits 0-5 same as corresponding bits in output word 1

bits 6-15 not used

Input words 2 and 3 are identical to output words 2 and 3.

## Invalid Configurations

The following configurations can be programmed, but are not acceptable to the Module, and causes the configuration error, input

word 0 bit 13, to be true and turn on the red FLT LED indicator if attempted.

- A configuration file that does not provide the ability to home the Module, either by means of a home limit switch and home limit switch operations, or quadrature encoder and marker pulse operations.
- A configuration file that does not contain a limit endpoint, either CW or CCW.
- A configuration file that specifies both quadrature encoder and diagnostic feedback.
- A configuration file that specifies a marker pulse home without specifying both a quadrature encoder and a home proximity limit switch.
- A configuration file that specifies a home proximity limit without specifying the home limit switch.
- A configuration file that specifies diagnostic feedback with CW and CCW pulse outputs.
- A configuration file that calls for a starting speed outside the design range (1-250,000 pulses per second).

# Programming Command Mode

## Output Words – SLC Processor to Stepper Controller

*Output Command Word 0 Bit Definition*

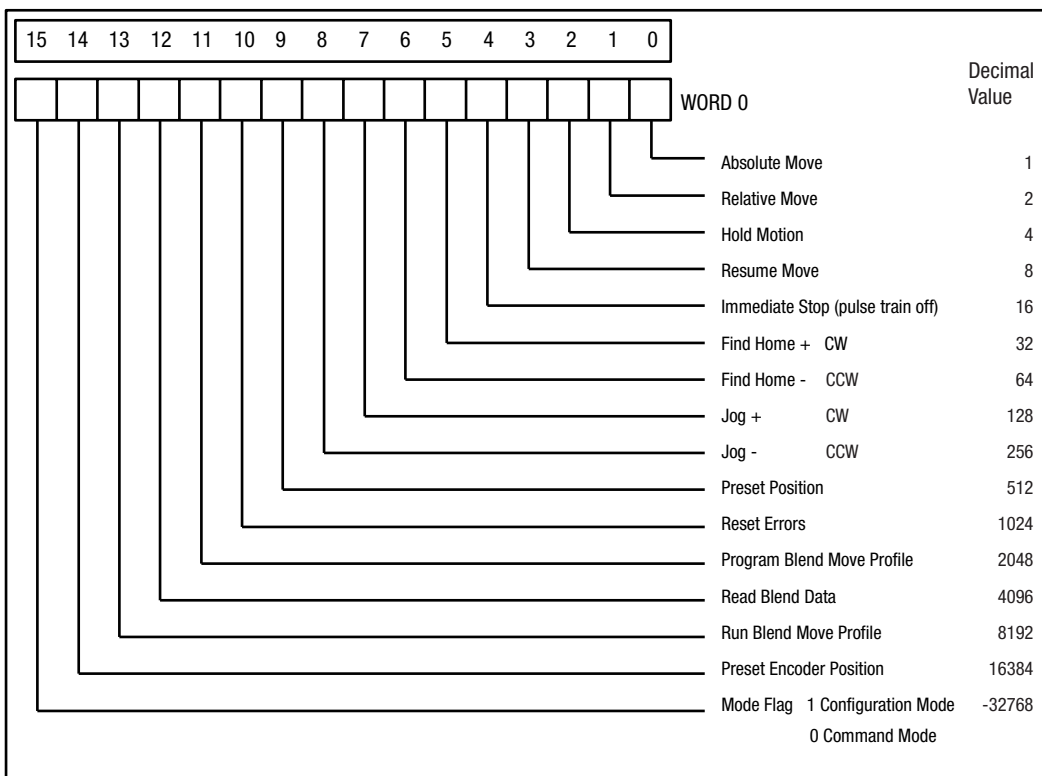

*Command Mode Output Words*

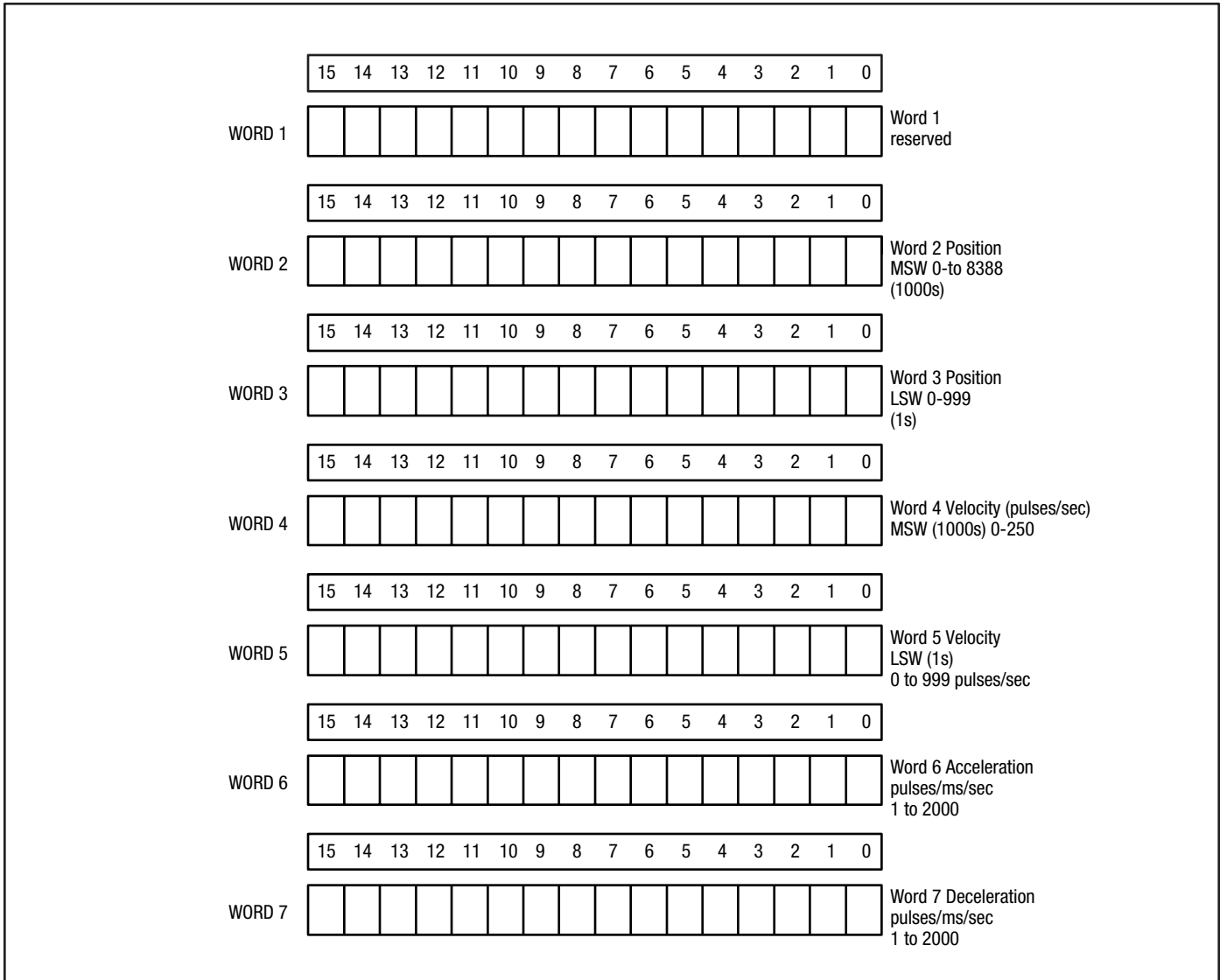

### Output Command Bits for Word 0

Bit	Description
0	Absolute Move
1	Relative Move
2	Hold Motion
3	Resume Move
4	Immediate Stop (pulse train off)
5	Find Home +/(Up)
6	Find Home –/(Down)
7	Jog +/(Up)
8	Jog –/(Down)
9	Preset Position
10	Reset Errors
11	Program Blend Move Profile
12	Read Blend Data
13	Run Blend Move Profile
14	Preset Encoder Position
15	Mode Flag:1 Configuration Mode 0 Command Mode

**Notes:**

1. A 0 to 1 transition of the above control bits must occur to cause the associated operation to take place.
2. Reaching either the CW or CCW limit switch during a normal move or jog operation is treated in the same manner as a pulse train enable/disable input. That is, the motor stops and the current position becomes invalid. The “one shot jog” feature defined in the Jog Commands, later in the chapter, must then be used to move the motor away from the limit switch.
3. The data format of output words 1-7 is decimal.
4. Most significant words (MSW) contain the 1000s places (the upper four digits) of the velocity and position data. The least significant word (LSW) contains the 1s, 10s and 100s places (the lower three digits).
5. A negative position value is indicated by setting the most significant bit in output word 2.
6. The position parameter has a range of  $\pm 8,388,607$ .
7. The velocity parameter has a range of starting speed  $\leq$  velocity  $\leq$  250,000.
8. The acceleration and deceleration parameters have a range of  $1 \leq$  acceleration/deceleration  $\leq$  2000 and is measured in pulses per millisecond per second.

**Absolute/relative move commands**

Set bit 0 to command an absolute move. Set bit 1 to command a relative move. Bit 15, the most significant bit of command mode output word 2 (msw position), can be used to denote a ccw move. A 1 produces a ccw move, while a 0 produces a cw move. Note that CCW and CW refer to direction of stepper motor rotation.

The current position of the axis must be valid in order to perform an absolute move, but not to perform a relative move. The current position is not valid following a “power-up” or a configuration operation.

**IMPORTANT**

A home operation or a preset must be performed to validate the current position.

In an absolute move, the number of pulses generated by the Module equals the difference between the target position (destination) and the current position.

In a relative move, the target position defines the distance (in pulses) that must be traveled relative to the current position.

Normally, both types of move accelerate to the programmed velocity (slew speed) at the commanded acceleration rate; continue at the velocity to a predetermined point; and then decelerate to the target position at the commanded deceleration rate to the starting speed and stop. This type of move generates a trapezoidal velocity profile, as illustrated below.

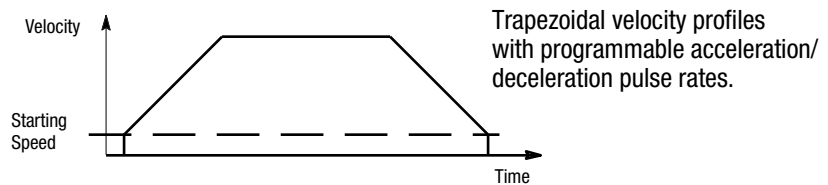

However, if a commanded move is not long enough to attain the programmed velocity before the deceleration point is reached, a triangular velocity profile is generated. This profile is shown below.

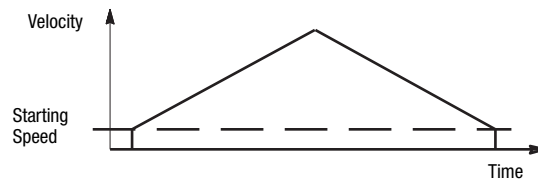

Blended Moves permit more sophisticated velocity profiles. The figure below is an example of a move containing 2 segments blended together.

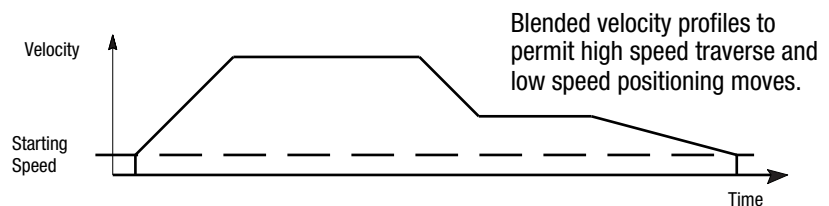

Upon successful completion of each move, the “move complete” bit (7) of command mode input word 0 is set, permitting the next move to proceed. Failure to complete a move generates an error signal, which sets the appropriate error flag in the command mode input word image table (bit 11, 12 or 13).

**Hold move command:** causes a controlled deceleration to the starting speed and stop. Upon completion of the hold stop, the hold state input (bit 2, word 0) of the command mode input word image table is set. While the hold move is in effect, velocity and acceleration or deceleration parameters can be changed. Specifying a new position, however, has no effect. If no error occurs during a hold move operation, the interrupted move can be resumed, with new velocity and acceleration or deceleration parameters, upon receipt of a resume move command.

---

**IMPORTANT**

If a hold move command is issued during a blend move operation, the Module runs the blend move profile to completion, and then set the “command error” bit (word 0, bit 12) in the command mode input image table. Hold does not stop a Jog move.

---

**Resume move command:** permits a previously held absolute or relative move to continue from the point of the hold. An interrupted blend move cannot be continued by a resume move command, however. The hold state input flag turns off when the resume move command has been acted upon.

A move can be held and then resumed a number of times, until one of the following occurs:

- The axis reaches its target position.
- An error condition occurs.
- Some other command is issued.

**Immediate stop (pulse train off) command:** brings a current move operation to a stop, without deceleration ramp. Bit 4 of command mode input word 0 is set. The position invalid bit (bit 10) also sets, if the axis was moving at the time the immediate stop command is issued.

---

**IMPORTANT**

It is possible to perform a Relative Move after an Immediate Interrupt has occurred. However, you can not resume an absolute move.

---

### **Find home + / (CW) and Find home – / (CCW) commands.**

The way in which these commands are executed is dependent on whether or not a home proximity limit switch is present (as selected in the configuration output image table). When a find home command is issued with a home proximity limit switch present, the axis accelerates to the programmed velocity and runs at that speed until the home proximity switch is detected. The axis then decelerates to the starting



speed and runs at that speed until the home limit switch is contacted or marker is detected (depending on which is configured), and then stops. Without a home proximity limit switch present, the axis speed moves at the configured starting speed until the home limit switch is detected. In this instance, the normal acceleration/deceleration and velocity parameters are disregarded.

The find home command requires the presence of at least one end limit switch, whether or not a home proximity switch is present. If only one end limit switch is used, it is the programmer's responsibility to ensure that the find home command has the correct direction (+ or -). The Module does not accept a find home command unless the corresponding end limit switch is present [CW limit switch for +/(CW) command; CCW limit switch for -/(CCW) command]. An incorrect find home command generates an invalid command input error.

## Homing Routines

### Home to Limit Switch

When Find Home is initiated, it performs the Home at base speed until the Limit Switch is found. It then stops and sets the position to zero.

### Home to Proximity Limit Switch and Home Limit Switch

When the Find Home command is issued, it homes at the commanded speed until the proximity switch is reached. It then moves at the base speed until it reaches the limit switch where it stops and sets the position to zero.

### Home to Proximity Limit Switch and Marker

When the Find Home command is issued, it moves at the commanded speed until it contacts the proximity switch. It then moves at the base speed until the marker is found. Upon finding the marker it stops and sets the position to zero.

If either of the end limit switches is reached during a home operation, the motor reverses direction and searches for the home limit or home proximity switch. For this reason, it is important to set the velocity at a low enough rate to guard against motor lock up during direction changes.

**Note:** If you are using a home limit switch and a home proximity limit switch and a right to left home command is required to home the axis, mount the home proximity limit switch to the right of the home limit switch. If a left to right home command is required, mount the limit switches opposite to the above. See the diagrams below to properly locate the home limit switches.

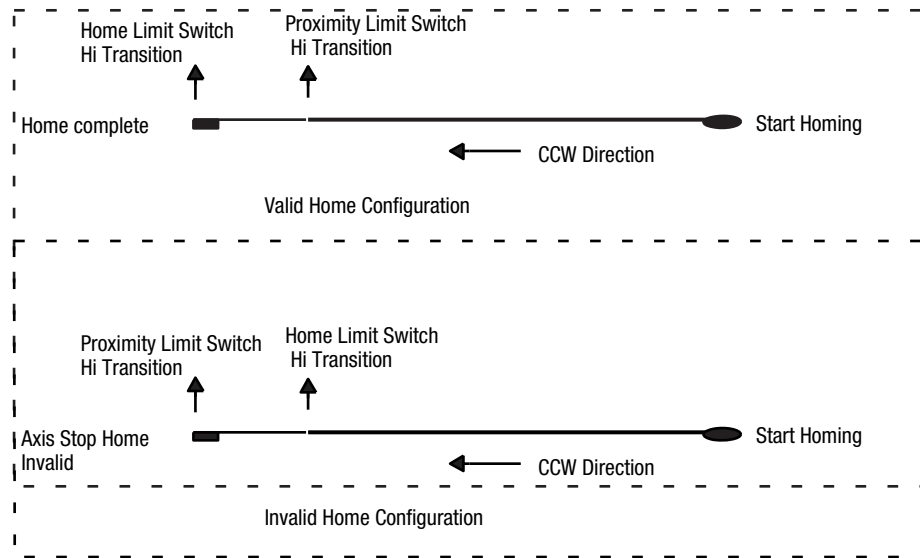

### Jog + / (CW) and Jog - / (CCW) commands.

This command causes the axis to operate in the jog mode, at the programmed velocity and in the designated direction. If the velocity specified for the jogging operation is below the programmed starting speed, the starting speed is ignored. However, if the specified velocity is above the starting speed, the axis jog move begins at the starting speed, accelerates to the specified velocity and runs at that velocity until one of the following occurs:

- The jog command bit is turned off.
- An external interrupt input is activated.
- The immediate stop output bit is set.
- The emergency stop input is activated.

When either the jog command is turned off or the external interrupt input is activated, the axis decelerates to the starting speed and then stops. The valid axis position is retained. If, however, either an immediate stop output bit is set or the pulse train enable/disable input is activated, the axis stops and the position is invalid.

**One Shot Jog:** When it is necessary to move the stepper motor while one of the inputs is active, the jog bit can be made to cause the

Module to output one pulse in the specified direction. This is referred to as a “one shot jog,” and can be made to occur during any 0 to 1 transition of the jog bit, while the velocity is set to zero speed.

**Preset position:** sets the current axis position to the programmed value. The desired position value is copied into the current position input words. If the position is currently invalid, issuing the preset position command causes the position to become valid.

**Reset errors:** clears all non-fatal errors detected by the Module. A non-fatal error is one from which the Module can recover. An example of a non-fatal error is a request for an absolute move when the current position is not valid. A non-fatal error inhibits all Module operations until the reset errors command is issued.

**Preset encoder position:** sets the current encoder position to the programmed value implied in command words 2 and 3.

## Programming Simple Moves

### General Information

Certain applications merely involve a series of moves to discrete positions, with a wait between moves. In this case, simply place the value for each position in words 2 and 3 of the slot address of the Module; then turn on bit 0 of word 0 of the slot address. Once the axis is moving, bit 0 can be turned off. The values for the velocity, acceleration, and deceleration are controlled by words 4 and 5, 6, and 7 respectively. This allows acceleration and deceleration to be programmed at different rates, if necessary.

### Data File Structures

SLC Processor data files can be used to determine the parameters for either simple or complex move profiles. The only difference between simple and complex moves is the method used to handshake with the Module. If speed blending of two or more moves is required, the programmer is responsible for handshaking the information from the SLC processor data file to the proper words assigned to the slot address. If either the starting speed or velocity changes with each move segment, the logic may be simplified by setting up additional files to transfer data from the files to the Module using a sequencer, move or copy instruction.

## Using the N Files for Motion Commands

The following example is used to denote an axis move equal to 1001 pulse counts, in the CW (+) direction. Word N9:23 contains the information in the (LSW) words which is the fine position in counts. These values can range from 0 to 999. Coarse position information is stored in word N9:22. The combination of coarse and fine position information determines how many counts the axis moves. If there is no coarse position information, a negative sign in the fine position word can be used to denote the axis direction. The move segment is made up of N9:22 and N9:23. N9:22 = 1 counts and N9:23 = 1 count. Motion commands are executed using the copy instruction as indicated in the program example represented by rung 3 of the “Application Examples” in Chapter 6 of this manual.

Function	Command	(Reserved)	Pos (MSW)	Pos (LSW)	Vel (MSW)	Vel (LSW)	Accel	Decel
Address	0	1	2	3	4	5	6	7
N9:20	1	0	1	1	10	0	6	6

## Quadrature Encoder Input

The Module supports a quadrature encoder with differential line driver outputs. The marker channel of the encoder is optional and provides an additional level of accuracy to the original home position (reference position), if required. The same circuitry is used for the loop back diagnostics and the quadrature encoder. The quadrature encoder output is read directly as counts and passed through to the backplane as the feedback value in words 4 and 5.

### **IMPORTANT**

If the encoder is used, it must be disconnected from the controller whenever loop back diagnostics are being performed.

## Use of Direct Inputs

There are a total of six direct inputs to the Module. They are: External Interrupt Input, Home Limit Switch Input, Home Proximity Switch Input, CW Limit Switch Input, CCW Limit Switch Input, and Pulse Train Enable/Disable Input. They connect to Module Input/Output

terminals 6 through 11, respectively. The Module responds to these direct inputs as follows:

- External Interrupt Input – When this input is turned on, the axis decelerates to the programmed starting speed, and then stops. This input works only when a jog operation is being performed. The axis does not stop if this input is activated during any other type of move operation.
- Home Limit Switch Input – Activating this input indicates to the Module that the current find home operation is complete, and stops axis motion.
- Home Proximity Switch Input – Activating this input during a find home operation affects the homing sequence. Refer to Find Home +/(CW), Find Home –/(CCW), earlier in this chapter for further information.
- CW or CCW Limit Switch Input – If either of these inputs is activated during a find home operation, the motor reverses direction and begins looking for the home limit switch or home proximity switch, as applicable. If either the CW or CCW limit switch input is activated during a normal move or jog move operation, the pulse train output is disabled immediately; the present position then becomes invalid.
- Pulse Train Enable/Disable Input – If this input is activated, the Module pulse train output to the motor ceases and the present position becomes invalid.

## Programming Blended Moves

### General Information

The blend move command permits the Module to blend motion segments together to create more complex move profiles. A move profile can consist of 2 to 16 segments. Each segment is defined by four parameters: absolute target position, velocity, acceleration rate, and deceleration rate.

The minimum amount of information required to define a new move segment is a change in both the absolute target position and the velocity. Changes in acceleration and deceleration rates are not required. If both a new target position and a new velocity are not specified, the command error input bit is set.

Blend move profiles can be programmed in a single block, and the segments stored in the internal memory of the Module. Each blend move profile is programmed as a series of absolute moves, which

means the axis position must be valid for a blend move operation to take place. The first segment of each blend move profile always starts at the programmed starting speed and accelerates up to the programmed velocity. The starting speed for the next segment in the profile is equal to the velocity specified for the previous segment.

---

**IMPORTANT**

The final segment stops at the specified starting speed and *must have* a programmed velocity equal to the starting speed, or a command error is generated. A command error is also generated if a direction reversal is encountered during a blend move operation.

---

Because the data for a blend move profile is stored in the Module memory, a profile can be run more than once. Since blend moves are made up of a series of absolute moves, the starting position for each blend move profile must be the same each time the profile is initiated. Note that other move or homing operations can be performed between reruns of the same blend move profile.

---

**IMPORTANT**

A command error is generated if a blend move is started from a different position.

---

## Blend move programming routine

Following is a description of how a typical blend move profile is programmed. For this discussion, it is assumed that the Module is in slot 2 of the SLC rack. The related ladder diagram follows the final step in the programming routine.

1. The SLC Processor sets the program blend move profile bit (O:2/11).
2. The Module responds by setting the blend move mode bit (I:2/8) and send next blend move data bit (I:2/9).
3. In response to the send next blend move data bit, the SLC Processor writes the data for the first blend move segment into the command mode output image table, and sets the read blend data bit (O:2/12).
4. The Module checks the first segment's data. If this data is not correct, the Module sets the command error bit (I:2/12). If the data is correct, the Module resets the send next blend move data bit (I:2/9).

5. Resetting the send next blend move data bit causes the SLC Processor to reset the read blend data bit (O:2/12).
6. The Module again sets the send next blend move data bit in response to resetting the read blend data bit.
7. The sequence described in steps 3 – 6 is repeated until all the segments making up the blend move profile have been read. The minimum number of segments is 2; the maximum number is 16.
8. When the last segment has been sent to the Module, the SLC Processor program resets the program blend move profile bit (O:2/11), and exits the blend move mode.
9. The Module then resets the blend move mode bit (I:2/8) and the send next blend move data bit (I:2/9).
10. When a blend move profile is to be run, the SLC Processor sets the run blend move profile bit (O:2/13). Note that no blend move profile can be run until this bit has been set.
11. When the run blend move profile bit has been set, the Module sets the blend move mode bit (I:2/8), and then executes the profile program.
12. After all segments in the profile have been run, the Module sets the move complete bit (I:2/7), and resets the blend move mode bit (I:2/8).
13. Steps 10, 11 and 12 can be repeated as long as the profile is started from the same position each time.

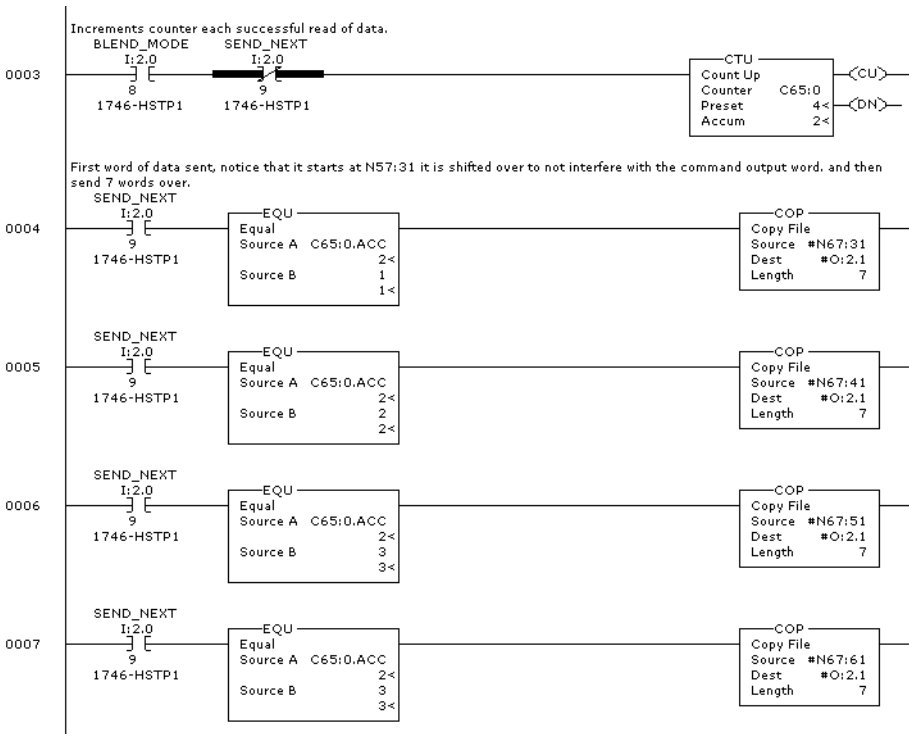
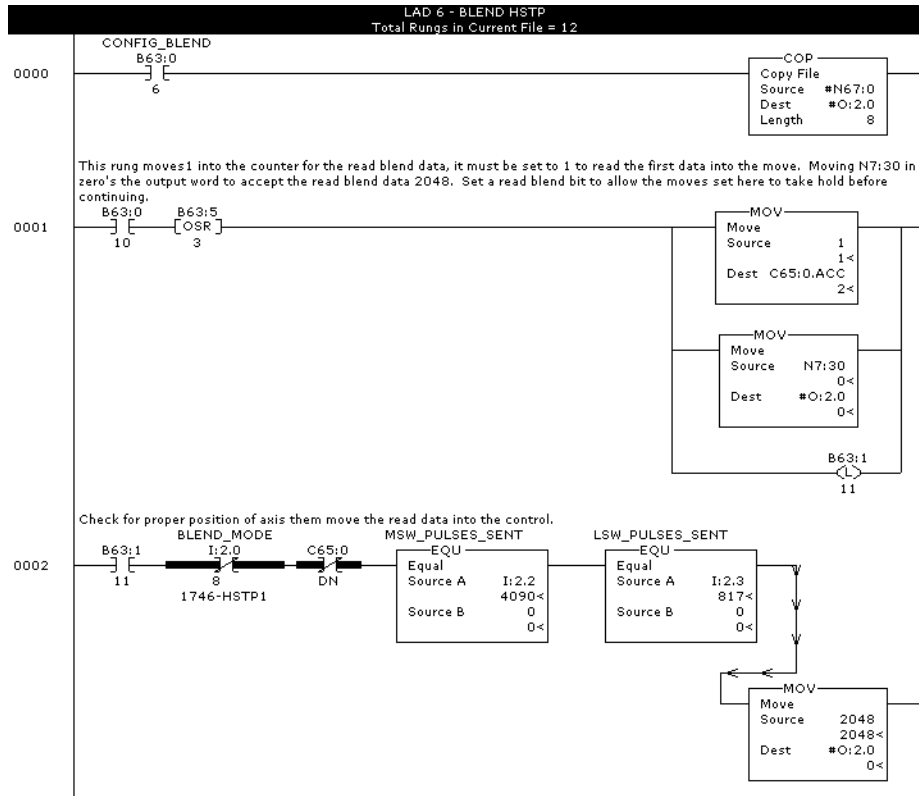



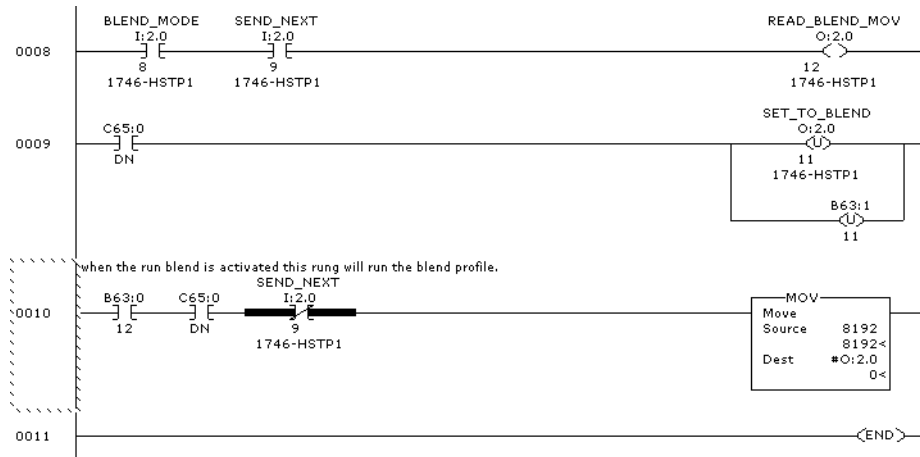

## Module Status Inputs

While the Module is operating in the command mode, its status is reported to the SLC Processor via the command mode input image table. This input file has the following format.

### Input Word 0

- bit 0 is set when the axis is moving CW
- bit 1 is set when the axis is moving CCW
- bit 2 is set when Module is in hold state
- bit 3 is set when axis is stopped (typically used with an immediate stop or a pulse train disable)
- bit 4 is set when axis is in home position
- bit 5 is set when axis is accelerating
- bit 6 is set when axis is decelerating
- bit 7 is set when current move is complete (not used with jog-type moves)
- bit 8 is set when Module is in blend move mode

bit 9	send next blend move data bit
bit 10	is reset if position is valid
bit 11	is set when input error exists
bit 12	is set when command error exists
bit 13	is set when configuration error exists
bit 14	is set when Module is OK
bit 15	mode flag:1 for configuration mode 0 for command mode

**Notes:**

1. Direction of travel (CW or CCW) is established looking at the shaft end of the stepper motor.
2. Bit 11 (Input Error) is set by activating either the CW or CCW limit switch, or by an immediate stop input. It can only be cleared by a home or a preset operation. The input error flag is not set if the correct end limit is reached during a normal home move operation, since reaching the end limit is an integral part of the home move operation.
3. Bit 14 (Module OK) is set as long as the Module is operating normally. Only a fatal error can reset this bit.

**Input Word 1**

bit 0	is set when CW limit switch input is active
bit 1	is set when CCW limit switch input is active
bit 2	is set when immediate stop input is active
bit 3	is set when external interrupt input is active
bit 4	is set when home limit switch input is active
bit 5	is set when home proximity limit switch input is active
bits 6-7	not used
bit 8	Home Invalid Bit
bits 9-15	not used

**Notes:**

1. When set, bit 3 (external interrupt) indicates that the Module has initiated a controlled stop, only during a jog operation. The stepper motor decelerates to the programmed starting speed, and then stops. The current position information is retained.
2. When set, bit 2 indicates an external pulse train enable/disable function has occurred. This identifies an uncontrolled stop, in which normal deceleration did not occur and axis position data is lost. This bit is set when a command is applied to input terminal 11 on the front panel of the module.
3. When set, bit 8 indicates that either the system has detected the wrong proximity to home switch sequence (i.e., proximity switch detected after already reading a transition on the home switch), or two different overtravel limit switches have been detected during a home operation.

**Input Words 2 and 3**

Input words 2 and 3 report current position data, based on the number of pulses that have been sent to the stepper motor. Note that this value may be different from the encoder value in words 4 and 5.

**Input Words 4 and 5**

Input words 4 and 5 report the axis position based on either feedback from an optional encoder attached to the stepper motor or diagnostic feedback when configured. Note that this value may be different from the current position in words 2 and 3. The value has a range of  $\pm 8,388,607$  counts, equalling the limits of the Module. The optical encoder values must be mechanically coupled to the motor. The optical encoder values are not updated to the SLC backplane unless a command is issued to the translator. Encoder direction values may be independent of the motor direction, e.g. motor direction may be the plus direction while encoder values decrease. The optical encoder values do not change unless the stepper motor is turning. It is possible for the encoder values to be increasing or decreasing independently of the direction of motor rotation.

**Diagnostics Feedback Test**

To perform a diagnostic feedback test, the Module must be configured for diagnostic feedback, using the loop back feature, and pulse and direction output. The external DC power supply must also be active,

in order to generate the output pulses. Wiring for the diagnostic feedback test is shown in the following diagram.

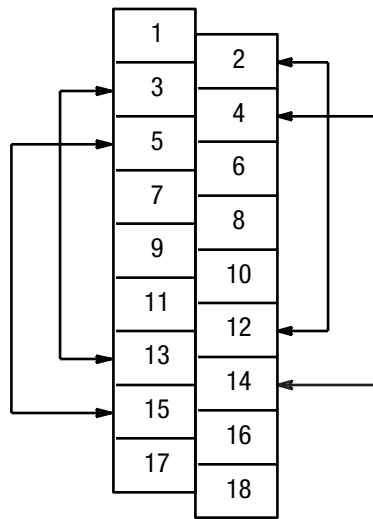

### Configuration Data for Loop Back Diagnostic Test

N9 Configuration for Loop Back Diagnostics Test:

N9:0-3120923100 00000

### Ladder Instructions for Loop Back Diagnostics Test

This rung is used to test the loopback information. Command should equal feedback when the move is complete. The Module is shown in slot 1 for this example.

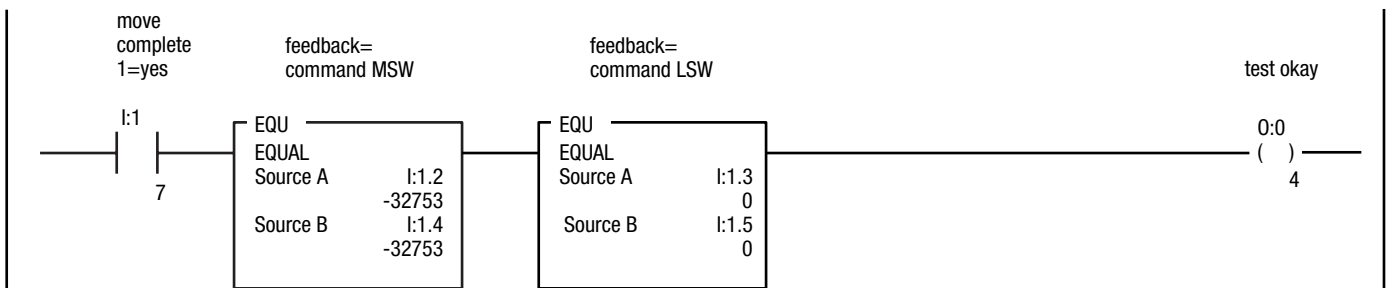

**NOTE:** In the above rung, use of the EQU (equal) test means that source A equals the command in both the MSW and LSW words; source B in both cases, is the value reported by the loop back diagnostic.

This rung is used to test the loopback to specific tolerances as defined by the less than and greater than tests. If the test fails the error output, SLC output 1 is turned on and the unit must be power cycled to reset it (based on this ladder logic).

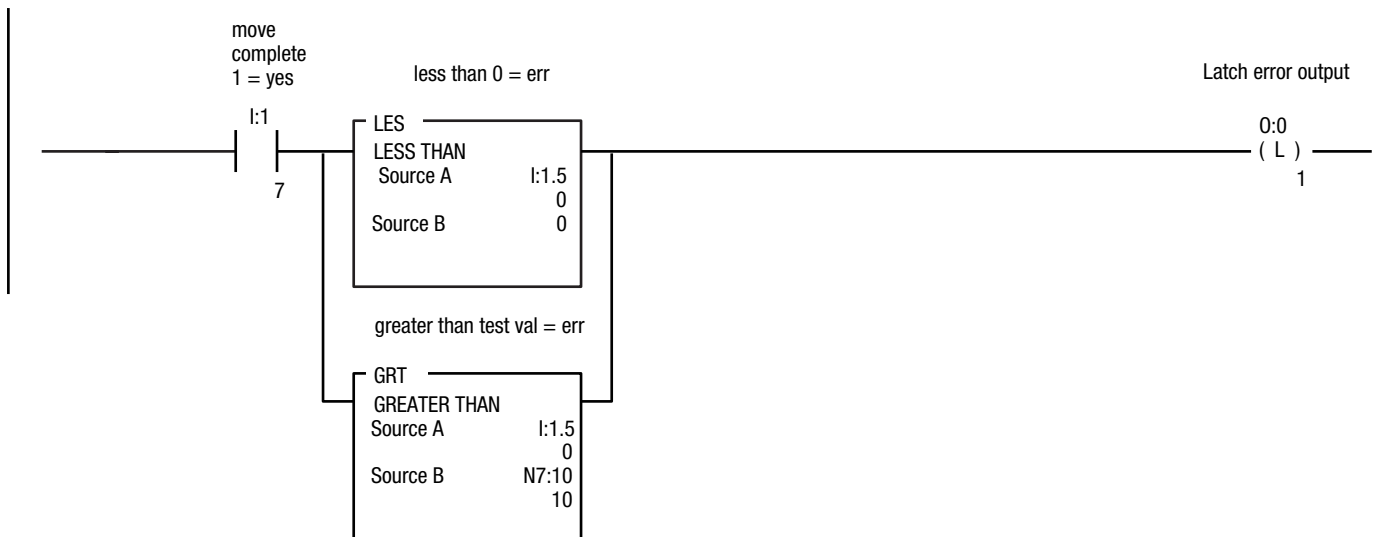

*Command Mode Input Words*

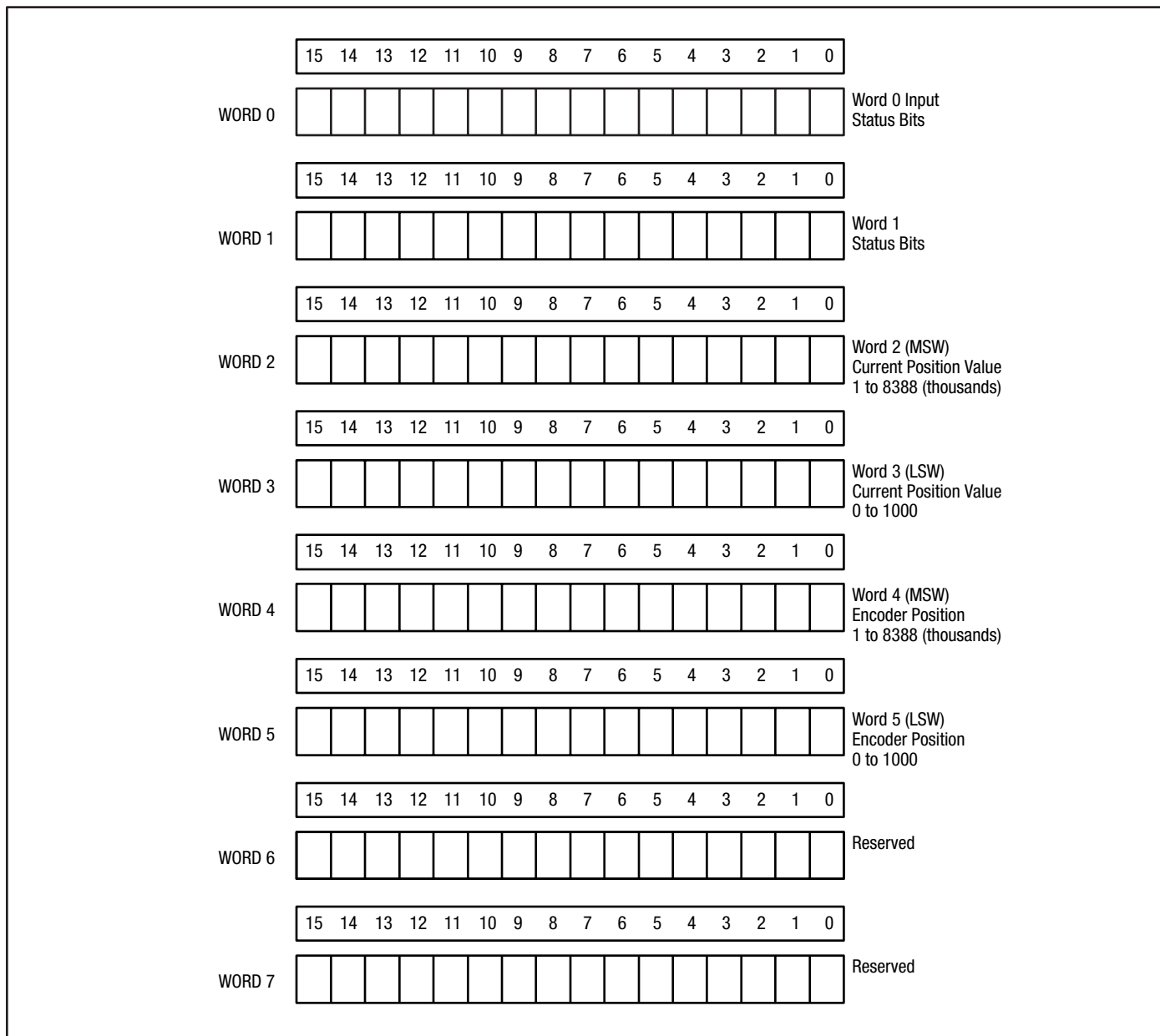

## Application Examples

### Chapter Objectives

This chapter contains an application example, in the form of a ladder diagram, to help you construct an actual program for the Module, using the SLC Processor.

### Data table used for the program listing for Sample Module Check Procedure

N29:0	-32751	17	1	0	0	0	0	0	0	0
N29:10	0	0	0	0	0	0	0	0	0	0
N29:20	1	0	10	0	100	0	2000	2000	0	0
N29:30	2	0	125	0	125	0	5	5	0	0
N29:40	4	0	0	0	0	0	0	0	0	0
N29:50	8	0	0	0	1	99	1000	1000	0	0
N29:60	16	0	0	0	0	0	0	0	0	0
N29:70	32	0	0	0	125	0	2000	2000	0	0
N29:80	64	0	0	0	125	0	2000	2000	0	0
N29:90	128	0	0	0	100	0	2000	1000	0	0
N29:100	256	0	0	0	1	0	1000	1000	0	0
N29:110	512	0	0	0	0	0	2000	2000	0	0
N29:120	1024	0	0	0	0	0	0	0		

### Program Listing for Sample Module Check Procedure

The following ladder diagram represents a sample program that can be used for a check of the Module. It is not intended as an actual operation program.



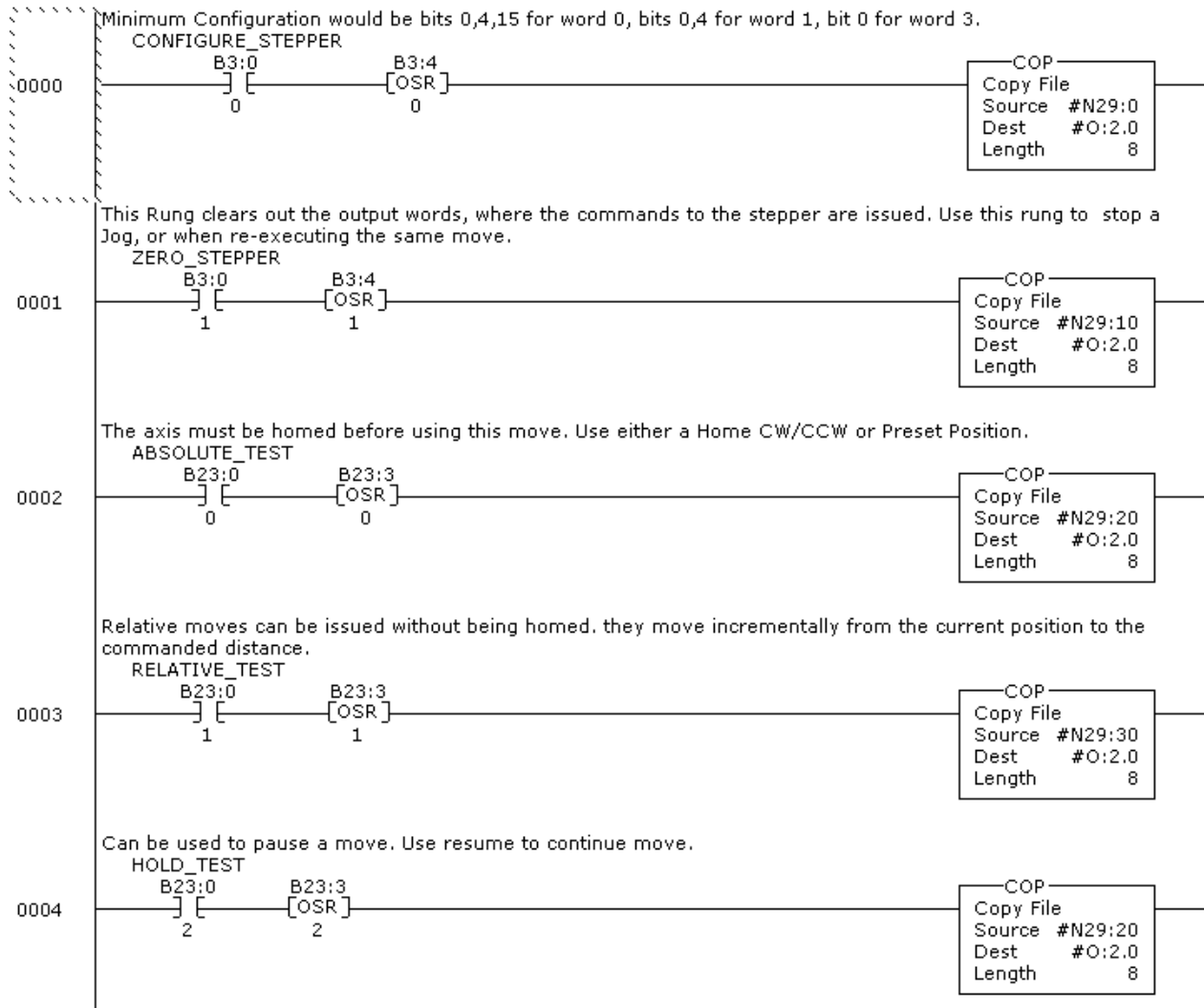

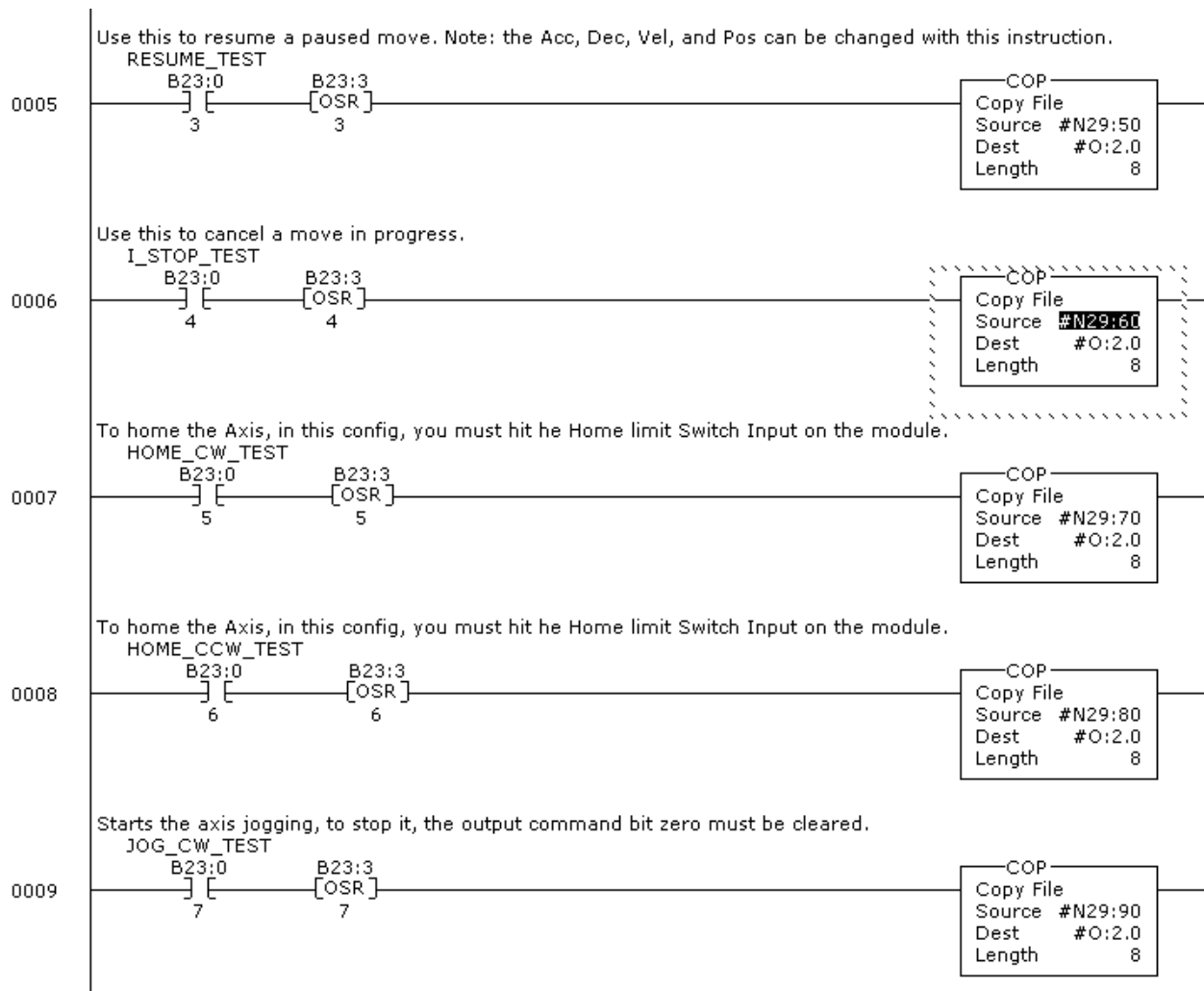

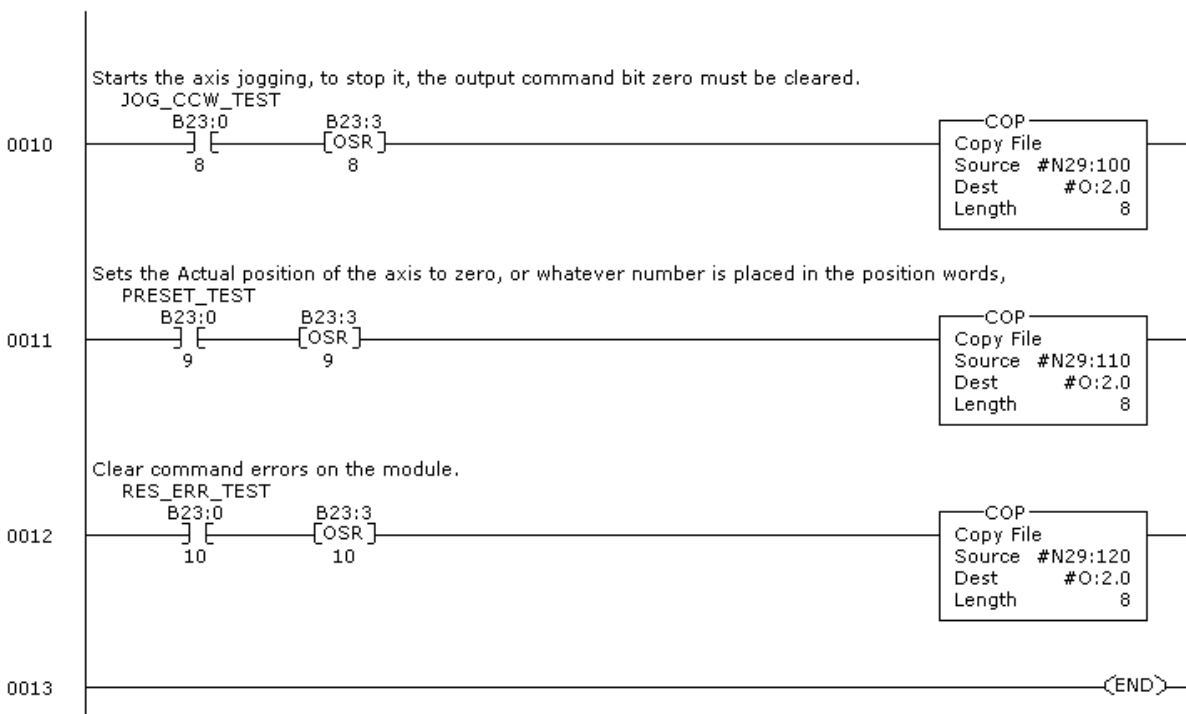

## Entering Negative Position Data

The position data is sign magnitude. There are three ways to easily assign a negative number:

- Using the ladder
- Manipulating the bits manually
- Calculating manually

To enter negative position data using the ladder:

1. Divide the absolute value into most (MSW) and least significant (LSW) words.
2. Use bitwise “inclusive or” with MSW and 32768.
3. Place the result in the position MSW, LSW.

To enter negative position data by manipulating the bits manually:

1. Divide the absolute value into MSW, LSW.
2. Enter both MSW and LSW into the position MSW,LSW via decimal.
3. Change radix to binary.
4. Set MSB (15) of the MSW.

To enter negative position data by calculating manually:

1. Divide the absolute value into MSW, LSW.
2. Enter the LSW value directly into position LSW.
3. Add the value of MSW to -32768.
4. Place the value into position MSW.

For example:

1.  $-5999 / \text{MSW,LSW} = 5, 999$
2. Assign position LSW = 999
3.  $5 + (-32768) = -32763$
4. Assign position MSW =  $-32763$

## **Converter Example**

The following diagram shows the ladder programming for a converter.

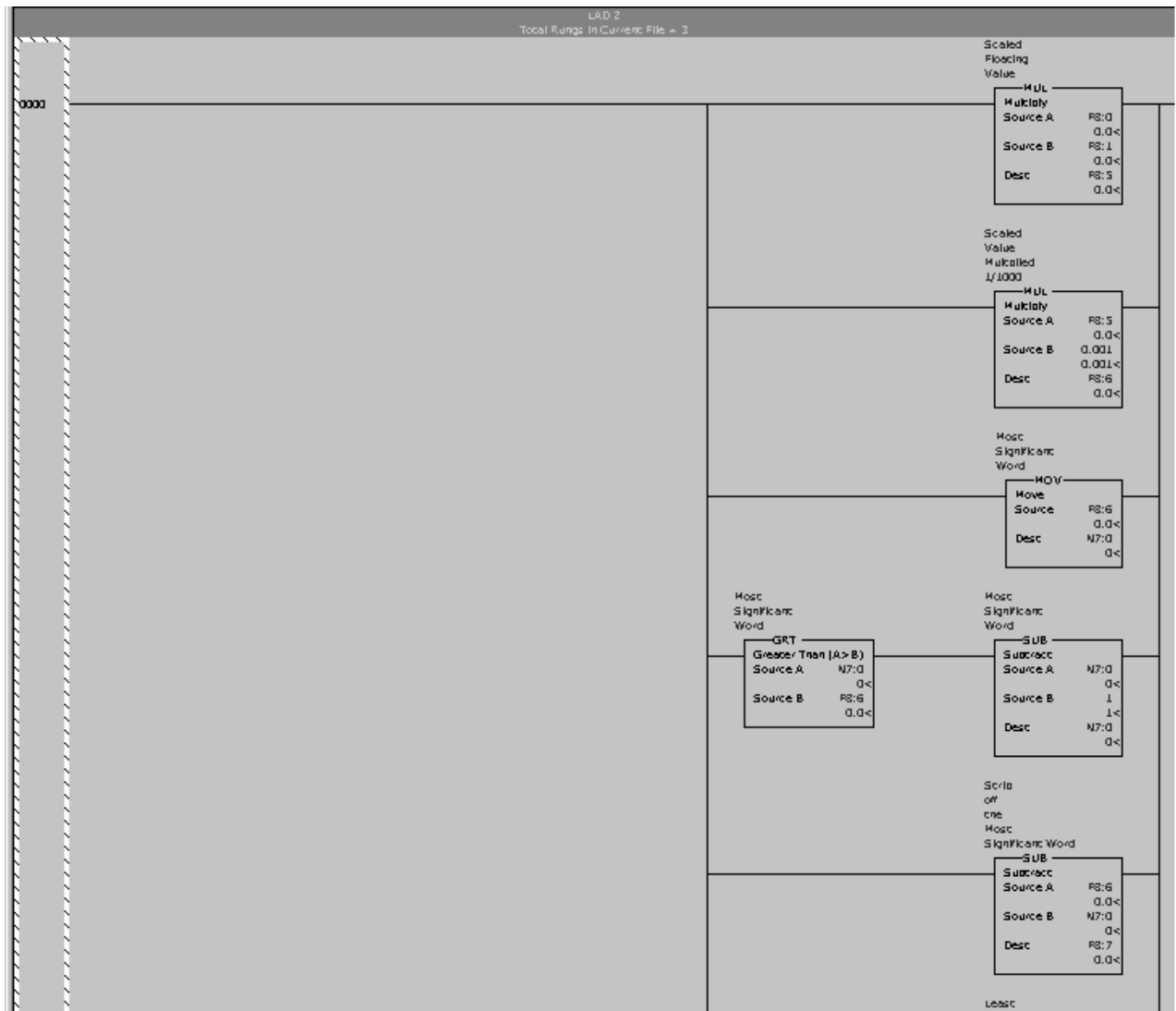

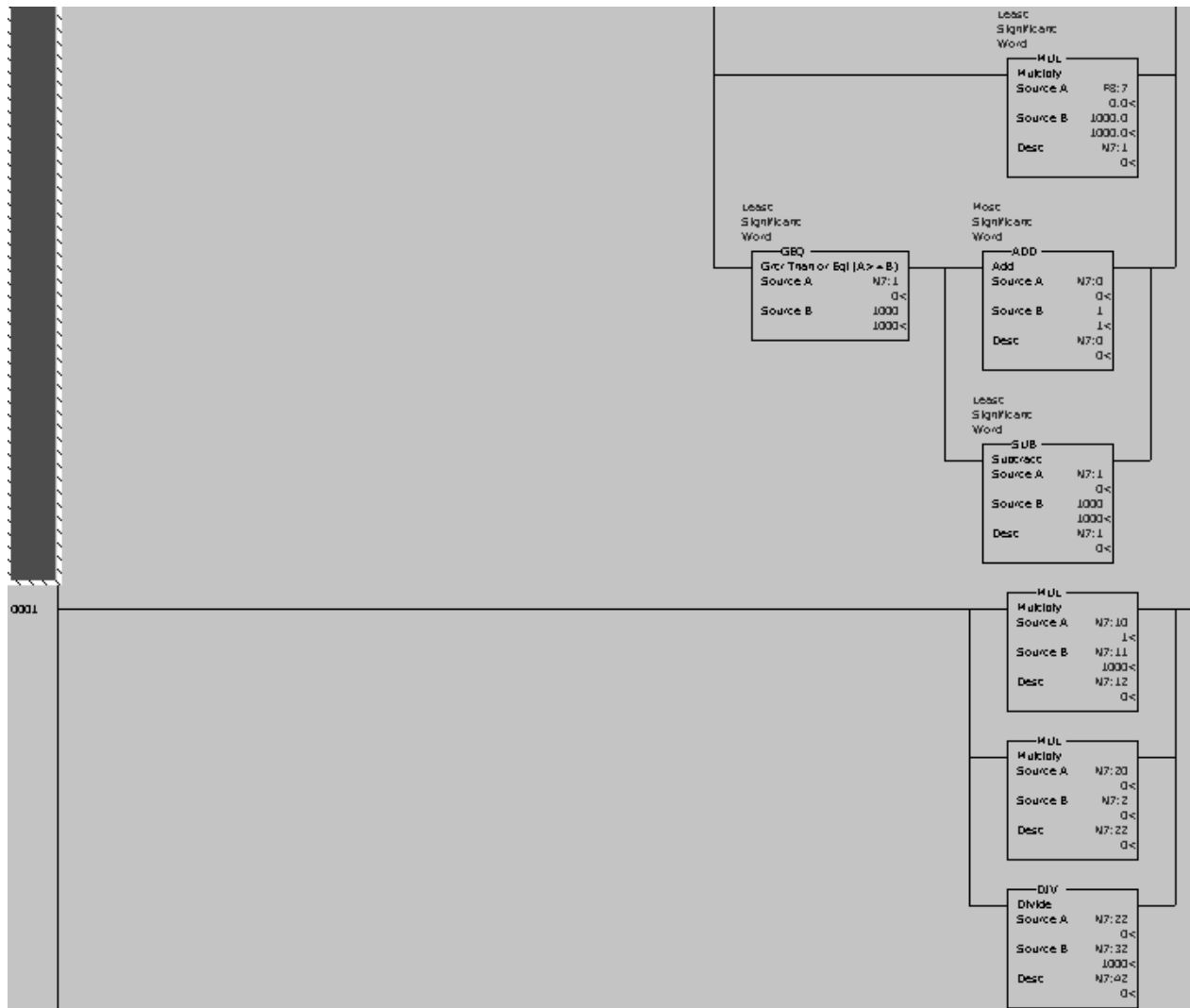



## Specifications

This chapter defines module design characteristics, both electrical and mechanical, and operating parameters relating to its application and compatibility with other system components.

### Industry Standards

- Backplane isolation to protect other Modules and the processor from external transient voltages.
- Motion is inhibited whenever the power up sequence is in progress or the SLC processor is placed in program mode.

### General Specifications

Number of Axes	1
Applicable Interfaces	Stepper motor driver
Pulse Train Switching	7 to 30 ma @ 5 VDC
Speed Range	1 to 250,000 pulses per second
Acceleration	1 to 2000 pulses per second Trapezoidal velocity profile
Acceleration Step Rate	4 milliseconds or less

### LED Indicators

Color	Description
Green	RUN – indicates the processor is running. Extinguished in case of watchdog timeout.
Green	CW – indicates motion in the clockwise direction.
Green	CCW – indicates motion in the counter-clockwise direction.
Red	Error – indicates data transfer error.
Red	Fault – lights when the Module is not configured.



## Power Requirements

- Backplane 5 Volts DC 2 A
- User Power 24 Volts DC 09A Max.

## System Limitations

Number of modules per chassis is limited by the SLC power supply and applications scan time requirements.

## Discrete Inputs

External Interrupt	(7-24 VDC) Single Ended
Home limit switch	(7-24 VDC) Single Ended
Home Proximity Input	(7-24 VDC) Single Ended
CW travel Limit input	(7-24 VDC) Single Ended
CCW travel Limit input	(7-24 VDC) Single Ended
Emergency Stop	(7-24 VDC) Single Ended
Encoder Channel A	(5 VDC) Differential
Encoder Channel B	(5 VDC) Differential
Encoder Marker Channel	(5 VDC) Differential

## Discrete Outputs

CW or non-directional pulse output	Differential Output
CCW pulse or direction signal output	Differential Output

## Input/Output Terminals

These terminals supply power and inputs to the Module and outputs to attached devices. They can accommodate two #14 gauge Wires.

## Environmental Operating Conditions

Operating / Inlet Air Temperature	0° to 60° C (32° to 140° F)
Altitude	up to 2000 M (6562 Ft)
Humidity	5 to 95% non-condensing

## Storage Temperature

−40° to 85° C (−40° to 185° F)

## Feedback Circuitry

- None required
- Optional Differential A quad B Encoder with marker Channel

## Program Storage Requirements

Applications Program Storage:	no local storage (uses SLC processor)
Applications Parameters Storage:	no local storage (uses SLC processor)
Module Address:	Determined by chassis location
Homing Method:	Determined by backplane configuration

## Processor Compatibility

Compatible SLC Processors: SLC 500™, SLC 5/01™, SLC 5/02™, SLC 5/03™, SLC 5/04™, and SLC 5/05™.



## Input/Output Quick Reference

**CONFIG OUTPUT WORD 0**

Bit 0	set when a CW limit switch is used
Bit 1	set when a CCW limit switch is used
Bit 2	set when the pulse train enable/disable input is used
Bit 3	set when an external interrupt is used
Bit 4	set when a home limit switch is used
Bit 5	set when a home proximity limit switch is used
Bit 6	not used
Bit 7	not used
Bit 8	set when a quadrature encoder is used
Bit 9	set when a diagnostic feedback is used
Bit 10	0 = output pulse type is CW/CCW pulse train 1 = output pulse type is pulse train and direction
Bit 11	not used
Bit 12	0 = limit switch home operation 1 = marker pulse home operation
Bit 13	not used
Bit 14	not used
Bit 15	0 = command mode 1 = configuration mode

**CONFIG OUTPUT WORD 1**

Bit 0	determines the active level of the CW limit switch
Bit 1	determines the active level of the CCW limit switch
Bit 2	determines the active level of the pulse train disable input
Bit 3	determines the active level of external interrupt input
Bit 4	determines the active level of the home limit switch input

**CONFIG INPUT WORD 0**

Bit 0	set when CW limit switch is configured
Bit 1	set when CCW limit switch is configured
Bit 2	set when pulse train enable/disable switch is configured
Bit 3	set when an ext interrupt is configured
Bit 4	set when a home limit switch is configured
Bit 5	set when a home proximity limit switch is configured
Bit 6	not used
Bit 7	not used
Bit 8	set when a quadrature encoder is configured
Bit 9	set when diagnostic feedback is configured
Bit 10	set when output pulse type is pulse train and direction
Bit 11	not used
Bit 12	reset when limit switch home operation is configured; set when marker pulse home is configured
Bit 13	configuration error: 0 = no error 1 = error
Bit 14	Module OK: 0 = fatal error encountered 1 = module operational
Bit 15	0 = command mode 1 = configuration mode

**CONFIG INPUT WORD 1**

Bit 0	reflects active level of the CW limit switch configured
Bit 1	reflects active level of the CCW limit switch configured
Bit 2	reflects active level of the pulse train disable input configured
Bit 3	reflects active level of the ext interrupt input configured
Bit 4	reflects active level of the home limit switch input configured

**CONFIG OUTPUT WORD 1**

Bit 5	determines the active level of the home proximity limit switch input
Bits 6 through 15	not used

**CONFIG OUTPUT WORDS 2 and 3**

Word 2	starting speed most significant word (MSW)
Word 3	starting speed least significant word (LSW)

**COMMAND OUTPUT WORD 0**

Bit 0	absolute move
Bit 1	relative move
Bit 2	hold motion
Bit 3	resume motion
Bit 4	immediate stop
Bit 5	find home +
Bit 6	find home –
Bit 7	jog +
Bit 8	jog –
Bit 9	preset position
Bit 10	reset errors
Bit 11	program blend move profile
Bit 12	read blend move profile
Bit 13	run blend move profile
Bit 14	preset encoder portion
Bit 15	mode flag:0 = command 1 = config

**COMMAND OUTPUT WORD 1**

reserved

**COMMAND OUTPUT WORD 2**

Position MSW 0 – 8338

**COMMAND OUTPUT WORD 3**

Position LSW 0 – 999

**CONFIG INPUT WORD 1**

Bit 5	reflects active level of the home prox limit switch input configured
Bits 6 through 15	not used

**CONFIG INPUT WORDS 2 and 3**

Word 2	reflects the starting speed most significant word as configured in output word 2
Word 3	reflects the starting speed least significant word as configured in output word 3

**COMMAND INPUT WORD 0**

Bit 0	set when the axis is moving CW
Bit 1	set when the axis is moving CCW
Bit 2	set when the module is in a hold
Bit 3	set when the axis is stopped
Bit 4	set when the axis is in home position
Bit 5	set when the axis is accelerating
Bit 6	set when the axis is decelerating
Bit 7	set when the current move is complete
Bit 8	set when the module is in a blend move mode
Bit 9	send next blend move data bit
Bit 10	reset if position is valid
Bit 11	set when input errors exist
Bit 12	set when a command error exists
Bit 13	set when a config error exists
Bit 14	set when the module is OK
Bit 15	mode flag:0 = command 1 = config

**COMMAND INPUT WORD 1**

Bit 0	set when CW limit switch is active
Bit 1	set when CCW limit switch is active
Bit 2	set when immediate stop input is active
Bit 3	set when external interrupt is active
Bit 4	set when home limit switch is active
Bit 5	set when home proximity limit switch is active
Bits 6 through 15	not used

**COMMAND OUTPUT WORD 4**

---

Velocity (pulses/sec) MSW 0 – 250

---

**COMMAND OUTPUT WORD 5**

---

Velocity (pulses/sec) LSW 0 – 999

---

**COMMAND OUTPUT WORD 6**

---

Acceleration (pulses/ms/sec) 1 – 2000

---

**COMMAND OUTPUT WORD 7**

---

Deceleration (pulses/ms/sec) 1 – 2000

---

**COMMAND INPUT WORDS 2 and 3**

---

report the current position data based on the number of pulses that have been sent to the stepper motor

---

**COMMAND INPUT WORDS 4 and 5**

---

report the axis position based on the feedback from an optional encoder

---



**A**

**application examples** 6-1

**C**

**chapter 1 objectives** P-1

**chapter 2 objectives** 1-1

**chapter 3 objectives** 4-1

**chapter 4 objectives** 5-1

**chapter 5 objectives** 6-1

**chapter 6 objectives** 2-1

**chapter 7 objectives** 3-1

**chapter 8 objectives** A-1

**configuration and programming** 5-1

**Configuration and Status Bits** 5-1

**Contents of Manual** P-1

**D**

**definitions** P-2

**diagnostics feedback test** 5-25

**E**

**encoder and feedback connections** 2-7

**examples** 6-1

**G**

**general precautions** 2-1

**general specifications**

discrete inputs A-2

discrete outputs A-2

environmental operating conditions A-3

feedback circuitry A-3

input/output terminals A-3

LED indicators A-1

power requirements A-2

processor compatibility A-3

program storage requirements A-3

storage temperature A-3

system limitations A-2

**H**

**Homing Routines** 5-14

Home to Limit Switch 5-14

Home to Proximity Limit Switch and Home Limit Switch  
5-14

Home to Proximity Limit Switch and Marker 5-14

**I**

**industry standards** A-1

**Input/Output Quick Reference** B-1

**installation and wiring** 2-1

**Intended Audience** P-2

**M**

**manual overview** P-1

**Module**

command mode operation 1-3

configuration mode 1-2

diagnostic mode 1-3

input/output terminals 1-5

LED Indicator diagnostics 1-4

operating modes 1-2

terminal block release screws 1-5

**Module Configuration** 5-3

**Module configuration**

configuration error 5-3

configuration mode input image table 5-6

configuration mode output image table 5-3

general information 5-3

invalid configurations 5-6

**Module operation** 4-1

**Module Overview** 4-1

**Module status**

configuration data for loop back diagnostic test 5-26

input word 0 5-22

input word 1 5-24

input words 2 and 3 5-25

input words 4 and 5 5-25

ladder instructions for loop back diagnostic test 5-26

**Module Status Inputs** 5-22

**Module status inputs** 5-21

**N**

**normal operation** 3-1

**O**

**Operating Modes** 4-1

**operating modes**

Command 4-2

configuration 4-1

fixed speed operation 4-2

operation using the pulse and direction outputs 4-2

origin (home) search sequence of operation 4-3

resetting the current absolute position 4-3



**operation** 3-1

## **P**

### **Processor configuration files**

program listing for sample module check procedure 6-1

### **product support, local**

telephone number P-3

### **Program Scan** 5-1

### **programming blended moves**

blend move programming routine 5-19

general information 5-18

### **Programming Command Mode** 5-8

### **programming command mode**

absolute/relative move commands 5-11

find home +/(CW) and find home -/(CCW) commands  
5-13

hold move command 5-13

immediate stop (pulse train off) command 5-13

jog +/(CW) and jog -/(CCW) commands 5-15

One Shot Jog 5-15

preset position 5-16

reset errors 5-16

resume move command 5-13

output command bits for word 0 5-10

output words - SLC Processor to Stepper Controller 5-8

### **Programming Conventions** 5-1

### **programming simple moves**

data file structures 5-16

general information 5-16

quadrature encoder input 5-17

use of direct inputs 5-17

using the N Files for motion commands 5-17

## **R**

### **removing the Module** 3-3

### **Rockwell Automation Support** P-2

### **Rockwell Automation support**

Local Product Support P-3

On the Web P-3

Technical product assistance P-3

## **S**

### **safety precautions** 3-1

### **SLC Processor**

configuration using APS 5-2

configuration using HHT (Catalog 1747-PT1) 5-2

### **SLC Processor Configuration** 5-1

### **SLC Processor configuration** 5-1

### **specifications** A-1

### **start up, operation and troubleshooting** 3-1

### **Starting and Stopping the Module** 2-2

### **Stepper Controller Module Overview** 1-1

### **Stepper Controller module overview** 1-1

### **System Start Up** 3-1

## **T**

### **terminology** P-2

CCW P-2

CW P-2

Engineering Units P-2

Input file P-2

Module P-2

Output file P-2

Physical outputs P-2

Position Loop P-2

SLC Processor P-2

Stepper Translator P-2

### **Troubleshooting** 3-1

### **typical encoder timing diagram** 2-6

### **typical input circuitry** 2-5

## **U**

### **using this manual** P-1

## **W**

### **Wiring** 2-2

### **Wiring for a Differential Interface** 2-2

### **Wiring Information for TTL Interface** 2-5

### **Wiring to Optocoupler Interface** 2-3

### **World Wide Web site** P-3

**[www.rockwellautomation.com](http://www.rockwellautomation.com)**

---

**Power, Control and Information Solutions Headquarters**

Americas: Rockwell Automation, 1201 South Second Street, Milwaukee, WI 53204-2496 USA, Tel: (1) 414.382.2000, Fax: (1) 414.382.4444

Europe/Middle East/Africa: Rockwell Automation, Vorstlaan/Boulevard du Souverain 36, 1170 Brussels, Belgium, Tel: (32) 2 663 0600, Fax: (32) 2 663 0640

Asia Pacific: Rockwell Automation, Level 14, Core F, Cyberport 3, 100 Cyberport Road, Hong Kong, Tel: (852) 2887 4788, Fax: (852) 2508 1846

Publication 999-121 - December 1999

Supersedes Publication 999-121 - January 1997

PN 1746-HSTP1

© 1999 Rockwell International Corporation. Printed in the U.S.A.