

STIHL BG 56, 66, 86, SH 56, 86

2011-06

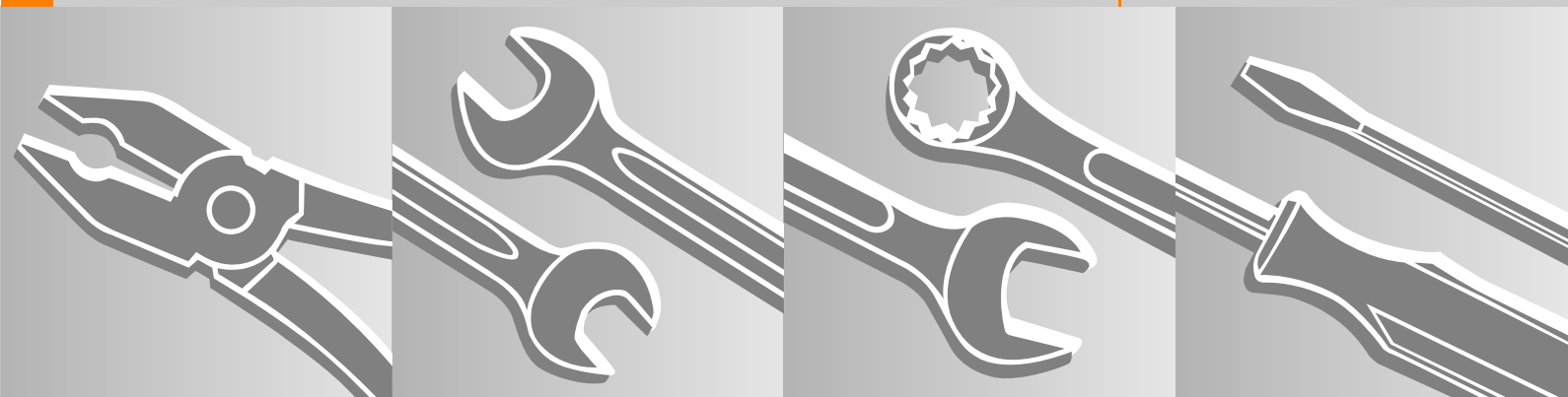

Contents

1.	Introduction	2	7.	Rewind Starter	43	10.5.3	Adjusting Engine Idle Speed	70
2.	Safety Precautions	3	7.1	General	43	10.6	Throttle Rod	71
3.	Specifications	4	7.2	Removing and Installing	43	10.7	Spacer Flange Removing and Installing	72
3.1	Engine	4	7.3	Pawl	43	10.8	Tank Vent	73
3.2	Fuel System	4	7.4	ErgoStart	44	10.8.1	Testing	73
3.3	Ignition System	4	7.5	Rope Rotor	45	10.8.2	Removing and Installing	74
3.4	Tightening Torques	5	7.6	Starter Rope / Grip	46	10.9	Fuel intake	74
4.	Troubleshooting	7	7.7	Tensioning the Rewind Spring	48	10.9.1	Pickup Body	74
4.1	Rewind Starter	7	7.8	Replacing the Rewind Spring	49	10.9.2	Fuel Hoses	75
4.2	Blower	8	7.9	Rope Guide Bushing	51	10.9.3	Fuel Tank Cap	76
4.3	Ignition System	9	8.	Antivibration System	53	11.	Blower and Vacuum Attachment	77
4.4	Carburetor	11	8.1	Removing and Installing	53	11.1	Intake Screen	77
4.5	Engine	14	8.2	Handle on SH 86, SH 86 C, BG 66 C, BG 86, BG 86 C	54	11.2	Blower Wheel	78
5.	Engine	15	9.	Control Levers	56	11.3	Removing and Installing Blower Housing on Models SH 56, SH 56 C, BG 56, BG 56 C, BG 66	79
5.1	Muffler / Spark Arresting Screen	15	9.1	Switch Positions	56	11.3.1	Removing and Installing Blower Housing on Models SH 86, SH 86 C, BG 66 C, BG 86, BG 86 C	79
5.2	Leakage Test	16	9.2	Setting Lever on SH 86, SH 86 C, BG 66 C, BG 86, BG 86 C	56	11.3.2	Removing and Installing Handle Housing on Models SH 86, SH 86 C, BG 66 C, BG 86, BG 86 C 80	
5.2.1	Preparations	16	9.3	Throttle Trigger on Models SH 56, SH 56 C, BG 56, BG 56 C, BG 66	57	11.4	Blower Tube – BG Models	80
5.2.2	Vacuum Test	17	9.4	Throttle Trigger on Models SH 86, SH 86 C, BG 66 C, BG 86, BG 86 C	58	11.5	Elbow – SH Models	81
5.2.3	Pressure Test	17	10.	Fuel System	60	11.6	Suction Tube – SH Models	81
5.3	Oil Seals	18	10.1	Air Filter	60	12.	Special Servicing Tools	82
5.4	Engine Removing and Installing	18	10.2	Baffle / Filter Housing	61	13.	Servicing Aids	84
5.5	Cylinder Removing and Installing	20	10.3	Removing and Installing the Carburetor	62			
5.6	Crankshaft	23	10.3.1	Leakage test	63			
5.6.1	Removing and Installing	23	10.4	Servicing the Carburetor	63			
5.7	Bearings / Crankshaft	25	10.4.1	Metering Diaphragm / Manual Fuel Pump	63			
5.8	Piston	26	10.4.2	Inlet Needle	65			
5.8.1	Piston Rings	29	10.4.3	Pump Diaphragm	65			
5.8.2	Piston Rings	29	10.4.4	Throttle Lever / Rotary Knob	67			
6.	Ignition System	30	10.4.5	Adjusting Screws	67			
6.1	Ignition Module	30	10.5	Adjusting the Carburetor	69			
6.1.1	Removing and Installing	30	10.5.1	Basic Setting	69			
6.2	Ignition Timing	32	10.5.2	Standard Setting	70			
6.3	Testing the Ignition Module	32						
6.4	Spark Plug Boot	33						
6.5	Flywheel	34						
6.6	Short Circuit Wire	35						
6.6.1	Testing	35						
6.6.2	Removing and Installing	35						
6.6.3	Ground Wire	39						
6.6.4	Stop Switch	39						
6.7	Ignition System Troubleshooting	40						

1. Introduction

This service manual contains detailed descriptions of all the repair and servicing procedures specific to this power tool.

You should make use of the illustrated parts lists while carrying out repair work. They show the installed positions of the individual components and assemblies.

Refer to the latest edition of the relevant parts list to check the part numbers of any replacement parts.

A fault on the machine may have several causes. To help locate the fault, consult the chapter on "Troubleshooting" and the "STIHL Service Training System" for all assemblies.

Refer to the "Technical Information" bulletins for engineering changes which have been introduced since publication of this service manual. Technical information bulletins also supplement the parts list until a revised edition is issued.

The special tools mentioned in the descriptions are listed in the chapter on "Special Servicing Tools" in this manual. Use the part numbers to identify the tools in the "STIHL Special Tools" manual. The manual lists all special servicing tools currently available from STIHL.

Symbols are included in the text and pictures for greater clarity. The meanings are as follows:

In the descriptions:

- = Action to be taken that is shown in the illustration (above the text)
- = Action to be taken that is not shown in the illustration (above the text)

In the illustrations:

- ➔ Pointer
- ➡ Direction of movement
- 📖 4.2 = Reference to another chapter, i.e. chapter 4.2 in this example.

Service manuals and all technical information bulletins are intended exclusively for the use of properly equipped repair shops. They must not be passed to third parties.

Always use original STIHL replacement parts. They can be identified by the STIHL part number, the **STIHL** logo and the STIHL parts symbol . This symbol may appear alone on small parts.

Storing and disposing of oils and fuels

Collect fuel or lubricating oil in a clean container and dispose of it properly in accordance with local environmental regulations.

2. Safety Precautions

If the power tool is started up in the course of repairs or maintenance work, observe all local and country-specific safety regulations as well as the safety precautions and warnings in the instruction manual.

Gasoline is an extremely flammable fuel and can be explosive in certain conditions.

Always wear suitable protective gloves for operations in which components are heated for assembly or disassembly.

Improper handling may result in burns or other serious injuries.

Do not smoke or bring any fire, flame or other source of heat near the fuel. All work with fuel must be performed outdoors only. Spilled fuel must be wiped away immediately.

Always perform leakage test after working on the fuel system and the engine.

3. Specifications

3.1 Engine

	BG 56, SH 56	BG 66, BG 66 C	BG 86, SH 86
Displacement:	27.2 cm ³	27.2 cm ³	27.2 cm ³
Bore:	34 mm	34 mm	34 mm
Stroke:	30 mm	30 mm	30 mm
Engine power to ISO 7293:	0.70 kW (1.0 bhp)	0.60 kW (0.8 bhp)	0.8 kW (1.1 bhp)
Maximum permissible engine speed (with nozzle):	6,800 rpm	5,800 rpm	7,200 rpm
Idle speed:	2,500 rpm	2,500 rpm	2,500 rpm
Engine leakage test under vacuum:	0.5 bar		
at gauge pressure:	0.5 bar		

3.2 Fuel System

Carburetor leakage test at gauge pressure:	0.8 bar
Operation of tank vent at gauge pressure:	0.5 bar
Fuel:	as specified in instruction manual

3.3 Ignition System

Air gap between ignition module and fanwheel:	0.15 ... 0.30 mm
---	------------------

Spark plug (resistor type):	BOSCH USR4AC NGK CMR 6 H
Electrode gap:	0.5 mm

3.4 Tightening Torques

DG and P (Plastoform) screws are used in polymer and light metal components. These screws form a permanent thread when they are installed for the first time. They can be removed and installed as often as necessary without impairing the strength of the screwed assembly, providing the specified tightening torque is observed.

For this reason it is **essential to use a torque wrench**.

Fastener	Thread size	For component	Torque	Remarks
			Nm	
Nut	M 5	Filter housing/carburetor/spacer flange	3.5	
Screw	P 5x18	Blower housing, outer/inner	3.0	
Screw	D 5x24	Blower housing, inner/crankcase	9.0	
Screw	D 5x24	Blower housing, inner/engine pan	8.0	
Screw	D 5x24	Blower housing, inner/cylinder	8.0	
Nut	M 8x1 L	Blower wheel/crankshaft	21.0	
Screw	P 5x18	Handle/cover/plug	3.0	
Screw	P 5x18	Handle/handle frame/plug	3.0	
Screw	P 5x18	Handle molding/blower housing, inner	3.0	
Screw	P 5x18	Handle molding/handle/handle frame/ plug	3.0	
Screw	D 5x60	Engine pan/crankcase/cylinder	9.0	
Screw	D 5x20	Fan housing/spiral housing	6.0	
Screw	D 5x20	Muffler/cylinder	9.0	
Nut	M 8x1	Flywheel/crankshaft	17.0	1)
Screw	D 5x20	Spiral housing/crankcase	6.0	
Screw	D 5x20	Spiral housing/engine pan	6.0	
	M 10x1	Spark plug	12.0	
Screw	D 4x18	Ignition module/cylinder	3.5	
Screw	D 5x20	Spacer flange/cylinder, stage 1	2.0	
		Spacer flange/cylinder, stage 2	6.0	

Remarks:

1) Degrease crankshaft/flywheel and mount oil-free

Use the following procedure when refitting a DG or P screw in an existing thread:

Place the screw in the hole and rotate it counterclockwise until it drops down slightly.
Tighten the screw clockwise to the specified torque.

This procedure ensures that the screw engages properly in the existing thread and does not form a new thread and weaken the assembly.

Power screwdriver setting for polymer: DG and P screws max. 500 rpm
Do not use an impact wrench for releasing or tightening screws.

Do not mix up screws with and without binding heads.

4. Troubleshooting

4.1 Rewind Starter

Condition	Cause	Remedy
Starter rope broken	Rope pulled out too vigorously as far as stop or over edge, i.e. not vertically	Fit new starter rope
	Normal wear	Fit new starter rope
Starter rope does not rewind	Very dirty or corroded	Clean or replace rewind spring
	Insufficient spring tension	Check rewind spring and increase tension
	Rewind spring worn	Fit new rewind spring
Starter rope cannot be pulled out far enough	Spring overtensioned	Check rewind spring and reduce tension
Starter rope can be pulled out almost without resistance (crankshaft does not turn)	Guide peg on pawl or pawl itself is worn	Fit new pawl
	Pawl spring fatigued	Fit new pawl spring
Models with ErgoStart	Spring broken or fatigued	Fit new ErgoStart spring
Starter rope is difficult to pull or rewinds very slowly	Starter mechanism is very dirty	Thoroughly clean complete starter mechanism
	Lubricating oil on rewind spring becomes viscous at very low outside temperatures (spring windings stick together)	Coat rewind spring with a small amount of standard solvent-based degreasant (containing no chlorinated or halogenated hydrocarbons), then pull rope carefully several times until normal action is restored

4.2 Blower

Always switch off the engine before working on the blower.

Condition	Cause	Remedy
No suction	Blower wheel loose	Tighten down nut on blower wheel firmly
	Blower wheel blocked	Clean blower housing
Poor suction	Catcher bag full	Empty the catcher bag
	Fan outlet blocked	Clean fan housing and outlet
	Blower wheel worn or too many blades broken	Fit a new blower wheel
Poor blowing performance	Intake screen very dirty	Clean intake screen and fan housing
	Blower wheel loose	Tighten down nut on blower wheel firmly
	Blower wheel worn or too many blades broken	Fit a new blower wheel
Leaves are not properly shredded	Shredder blade loose or worn	Tighten down or replace the shredder blade

4.3 Ignition System

Exercise extreme caution while carrying out maintenance and repair work on the ignition system. The high voltages which occur can cause serious or fatal accidents.

Condition	Cause	Remedy
Engine runs roughly, misfires, temporary loss of power	Spark plug boot is loose	Press boot firmly onto spark plug and fit new spring if necessary
	Spark plug sooted, smeared with oil	Clean the spark plug or replace if necessary.
	Fuel/oil mixture – too much oil	Use correct mixture of fuel and oil
	Incorrect air gap between ignition module and flywheel	Set air gap correctly
	Flywheel shows signs of damage (e.g. scores) or pole shoes have turned blue	Install new flywheel
	Ignition timing out of adjustment, flywheel warped, key in flywheel sheared	Install new flywheel
	Flywheel magnetization weak – pole shoes have turned blue	Install new flywheel
	Irregular spark	Check operation of stop switch and ignition module Check ignition lead/module, replace ignition module if necessary Check ignition lead and short circuit wire for damaged insulation or break and replace if necessary. Check operation of spark plug. Clean the spark plug or replace if necessary.

The carburetor or engine may also be the cause of poor engine running behavior

Condition	Cause	Remedy
No spark	Spark plug faulty	Install new spark plug
	Faulty insulation or short in short circuit wire	Check short circuit wire for short circuit to ground
	Break in ignition lead or insulation damaged	Check ignition lead, replace ignition module if necessary.
	Ignition module faulty	Install new ignition module

4.4 Carburetor

Condition	Cause	Remedy
Carburetor floods; engine stalls	Inlet needle not sealing – Foreign matter between valve seat and sealing cone or sealing cone worn	Remove and clean the inlet needle, clean the carburetor
	Inlet control lever sticking on spindle	Clean the inlet control lever or replace if necessary.
	Helical spring not located on nipple of inlet control lever	Remove the inlet control lever and refit it correctly
	Perforated disc on diaphragm is deformed and presses constantly against the inlet control lever	Fit a new metering diaphragm
Poor acceleration	Setting of low speed screw too lean	Check basic carburetor setting, correct if necessary
	Setting of high speed screw too lean	Check basic carburetor setting, correct if necessary
	Inlet needle sticking to valve seat	Remove inlet needle, clean and refit
	Diaphragm gasket leaking	Fit new diaphragm gasket
	Metering diaphragm damaged or shrunk	Fit a new metering diaphragm
	Spacer flange damaged	Install new spacer flange

Condition	Cause	Remedy
Engine will not idle, idle speed too high	Throttle shutter opened too wide by idle speed screw (LA)	Reset idle speed screw (LA) correctly
	Oil seals/engine leaking	Seal or replace oil seals/engine
	Throttle shutter stiff or torsion spring on throttle shaft fatigued or broken	Free off throttle shaft or install new carburetor
Engine stops while idling	Idle jet bores or ports blocked	Clean the carburetor
	Low speed screw too rich or too lean	Reset low speed screw (L) correctly
	Setting of idle speed screw incorrect – throttle shutter completely closed	Reset idle speed screw (LA) correctly

Condition	Cause	Remedy
Engine speed drops quickly under load – low power	Air filter dirty	Clean air filter or replace if necessary
	Throttle shutter not opened fully	Check rod
	Tank vent faulty	Replace tank vent
	Fuel pickup body dirty	Install new pickup body
	Fuel strainer dirty	Clean fuel strainer in carburetor, replace if necessary
	Leak in the fuel suction hose	Fit new fuel suction hose
	Setting of high speed screw (H) too rich	Check basic carburetor setting, correct if necessary
	Main jet bores or ports blocked	Clean or replace the carburetor
	Pump diaphragm damaged or fatigued	Fit new pump diaphragm

4.5 Engine

Always check and, if necessary, repair the following parts before looking for faults on the engine:



- Air filter
- Fuel system
- Carburetor
- Ignition system

Condition	Cause	Remedy
Engine does not start easily, stalls at idle speed, but operates normally at full throttle	Oil seals in crankcase damaged	Replace the oil seals
	Engine leaking or damaged (cracks)	Seal or replace the engine
Engine does not deliver full power or runs erratically	Piston rings worn	Fit new piston rings
	Muffler / spark arresting screen carbonized	Clean the muffler (inlet and exhaust), replace spark arresting screen, replace muffler if necessary
	Air filter dirty	Replace air filter
	Fuel suction hose kinked or torn	Fit new hoses or position them free from kinks
	Tank vent faulty	Check the tank vent and replace if necessary.
Engine overheating	Insufficient cylinder cooling. Air inlets in fan housing blocked or cooling fins on cylinder very dirty	Thoroughly clean all cooling air openings and the cylinder fins.

5. Engine

5.1 Muffler / Spark Arresting Screen

Always check and, if necessary, repair the fuel system, carburetor, air filter and ignition system before looking for faults on the engine.

- Troubleshooting,  4.5
- Remove the fan housing,  7.2

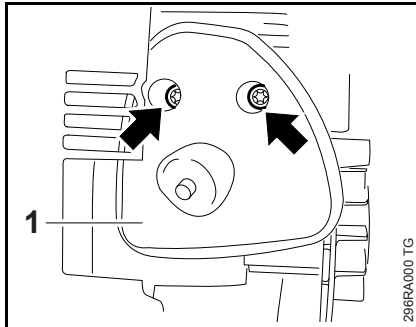

- Take out the screws (arrows).
- Remove the muffler (1), check and replace if necessary.

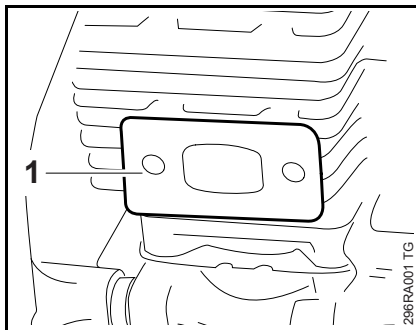

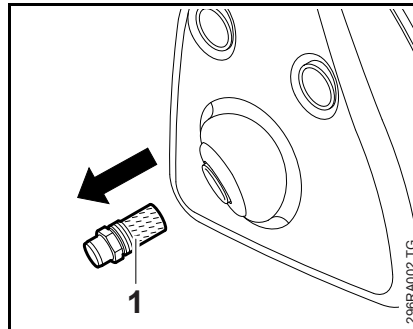

- Remove the gasket (1).

Spark arresting screen (not all markets)

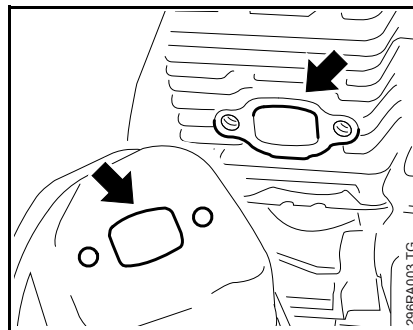

- Unscrew the stub with spark arresting screen (1).
- Clean the stub with screen (1) or replace if necessary.
- Reassemble in the reverse sequence.



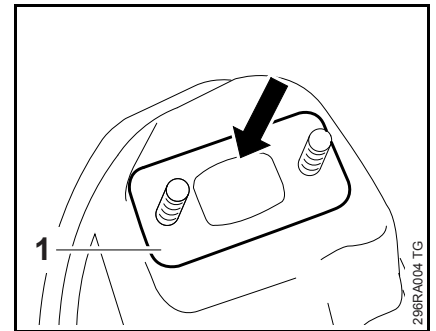

- Inspect and clean the sealing faces (arrows),  13

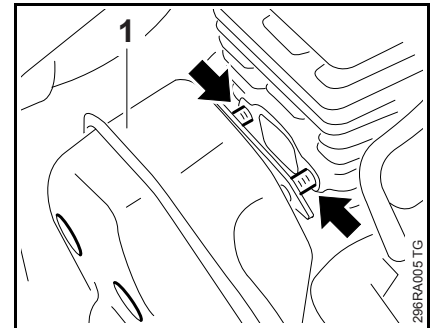

- Insert the screws through the holes in the muffler.
- Push the gasket (1) over the screws – the gasket is held in position.



- Carefully place the muffler (1) in position.
- Line up the screws (arrows) and check the position of the gasket.
- Insert the screws (arrows) and tighten them down firmly.
- Install the fan housing,  7.2
- Tightening torques,  3.4

5.2 Leakage Test

Defective oil seals and gaskets or cracks in castings are the usual causes of leaks. Such faults allow supplementary air to enter the engine and upset the fuel-air mixture.

This makes adjustment of the prescribed idle speed difficult, if not impossible.

Moreover, the transition from idle speed to part or full throttle is not smooth.

Always perform the vacuum test first and then the pressure test.

The engine can be checked thoroughly for leaks with the pump 0000 850 1300.

5.2.1 Preparations

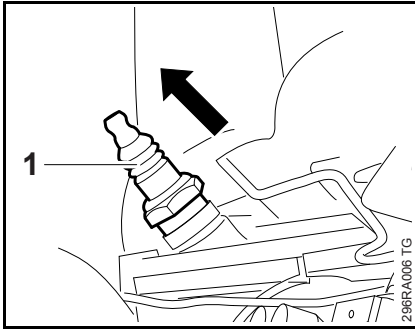

- Remove the fan housing, 7.2
- Pull the boot off the spark plug.
- Unscrew the spark plug (1).
- Set the piston to top dead center. This can be checked through the spark plug hole.

- Fit the spark plug (1) and tighten it down firmly.
- Tightening torques, 3.4

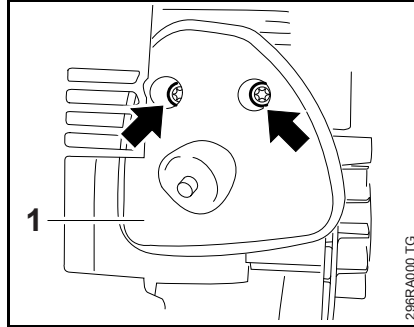

- Loosen the screws (arrows).
- Lift the muffler (1).

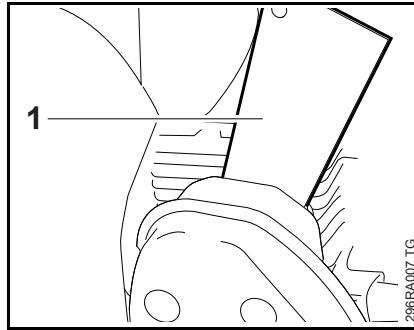

- Fit the sealing plate (1) 0000 855 8106 between the cylinder exhaust port and muffler and tighten down the screws moderately.

The sealing plate must completely fill the space between the two screws.

- Remove the carburetor, 10.3

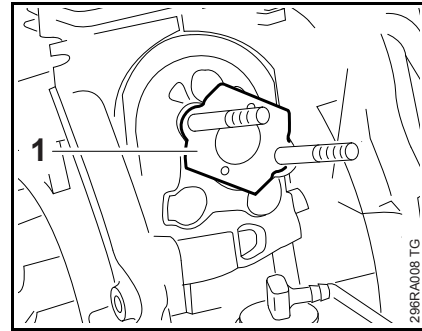

Check that the gasket (1) is in position.

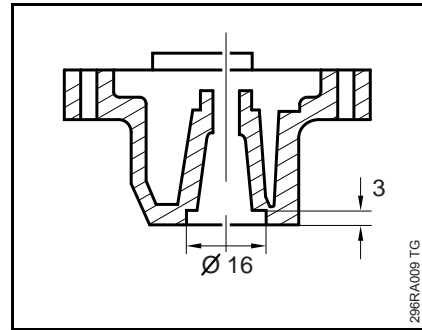

Test flange (1) 1128 850 4200 can be modified as shown above.

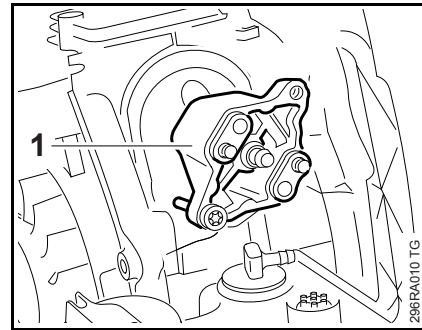

- Fit the test flange (1) 5910 850 4200.

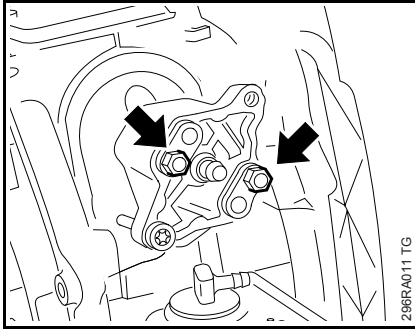

- Fit the nuts (arrows) and tighten them down firmly.

5.2.2 Vacuum Test

Oil seals tend to fail when subjected to a vacuum, i.e. the sealing lip lifts away from the crankshaft during the piston's induction stroke because there is no internal counterpressure.

A test can be carried out with pump 0000 850 1300 to detect this kind of fault.

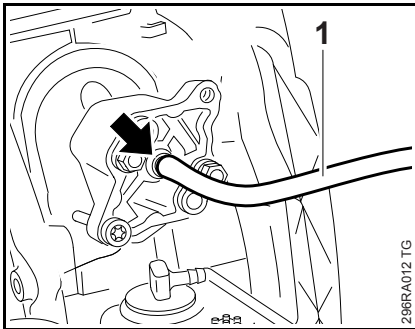

- Connect suction hose (1) of pump 0000 850 1300 to the nipple (arrow).

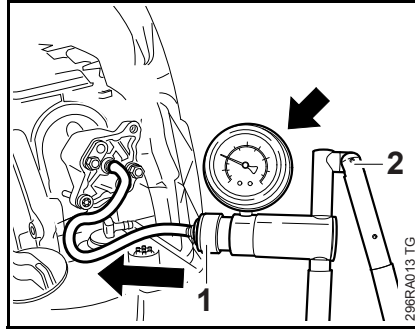

- Push ring (1) to the left
- Operate the lever (2) until the pressure gauge (arrow) indicates a vacuum of 0.5 bar.

If the vacuum reading remains constant, or rises to no more than 0.3 bar within 20 seconds, it can be assumed that the oil seals are in good condition.

However, if the pressure continues to rise (reduced vacuum in the engine), the oil seals must be replaced, [5.3](#).

- After finishing the test, push the ring to the right to vent the pump.
- Continue with pressure test, [5.2.3](#)

5.2.3 Pressure Test

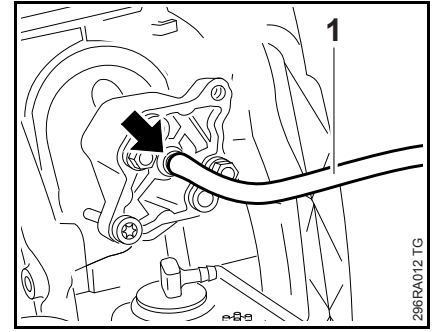

Carry out the same preparations as for the vacuum test, [5.2.2](#)

- Always carry out the pressure test after the vacuum test, [5.2.2](#)
- Connect pressure hose (1) of pump 0000 850 1300 to the nipple (arrow).

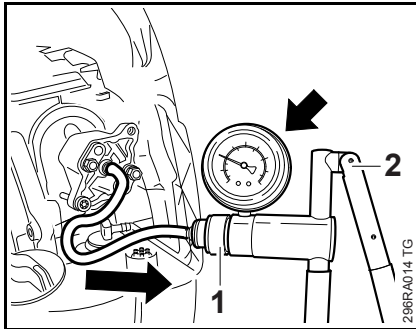

- Push ring (1) to the right
- Operate the lever (2) until the pressure gauge (arrow) indicates a pressure of 0.5 bar. If this pressure remains constant for at least 20 seconds, the engine is airtight.

- If the pressure drops, the leak must be located and the faulty part replaced.

To find the leak, coat the suspect area with oil and pressurize the engine. Bubbles will appear if a leak exists.

- After finishing the test, push the ring to the left to vent the pump – disconnect the hose.
- Remove the test flange.
- Install the carburetor, [10.3](#)
- Loosen the muffler and pull out the sealing plate.
- Tighten down the muffler firmly.
- Reassemble all other parts in the reverse sequence.
- Tightening torques, [3.4](#)

5.3 Oil Seals

The engine must be disassembled to replace the oil seals.

- Remove the engine, [5.4](#)
- Remove the engine pan, [5.6](#)

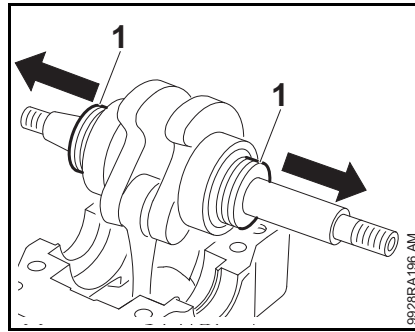

- Pull the crankshaft upwards a little but not out of the cylinder.

- Pull off the oil seals (1).
- Clean the sealing faces and install new oil seals, [5.6](#)
- Install the engine pan, [5.6](#)
- Degrease the crankshaft taper, [13](#)
- Install the engine, [5.4](#)

5.4 Engine Removing and Installing

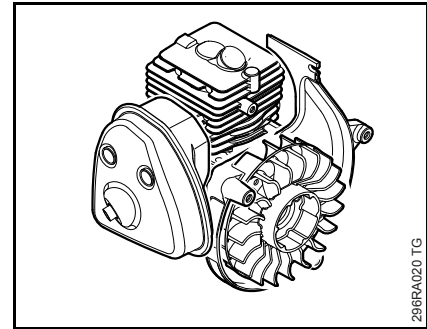

The complete engine has to be removed for access to the piston, cylinder and crankshaft.

- Remove the fan housing, [7.2](#)
- Pull the boot off the spark plug.
- Remove the air filter, [10.1](#)
- Remove the filter housing, [10.2](#)
- Remove the throttle rod, [10.6](#)
- Unscrew the spark plug.

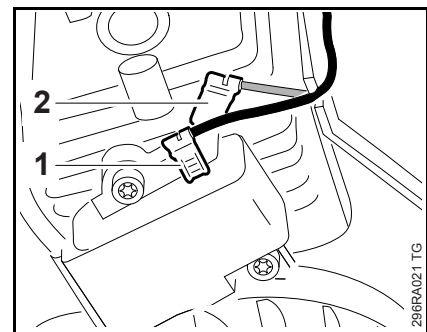

- Disconnect the short circuit wire (1) and ground wire (2).
- Put the wires to one side.

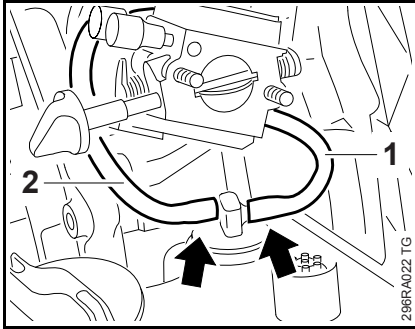

- Disconnect the fuel suction hose (1) and fuel return hose (2) from the stubs (arrows) on the connector.

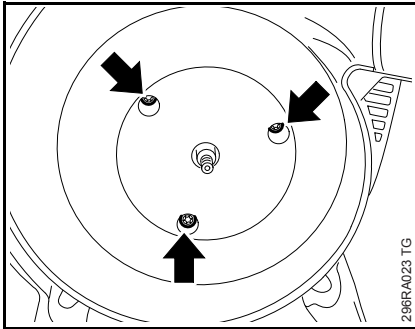

- Remove the blower wheel, [11.2](#)
- Take out the screws (arrows).

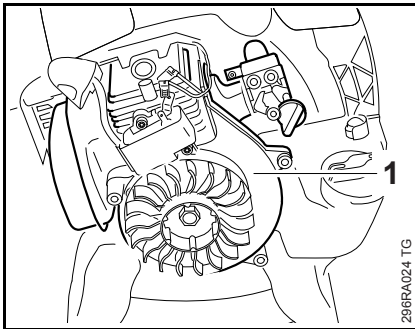

- Pull the complete engine (1) out of the blower housing.

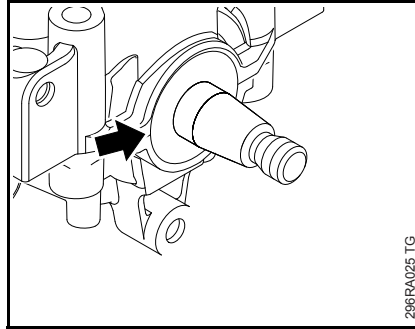

- Check the engine and install a new cylinder, piston, crankshaft or crankcase if necessary – after removing the muffler, ignition module and spacer flange.

It is not necessary to disassemble the engine any further to replace the oil seals.

- Inspect the oil seals and replace if necessary, [5.6](#)
- Check that the oil seals are correctly seated – they must be flush with the edge (arrow) of the crankcase.

Installing

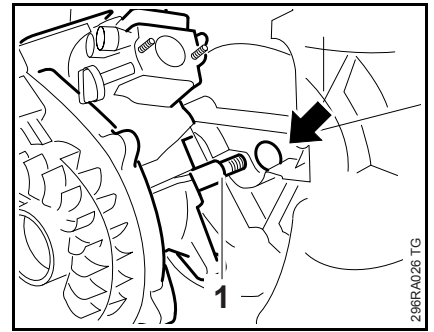

Take care to avoid pinching the short circuit and ground wires between the engine and blower housing.

- Push the straight crankshaft stub (1) into the blower housing bore (arrow).
- Push the engine against the blower housing.

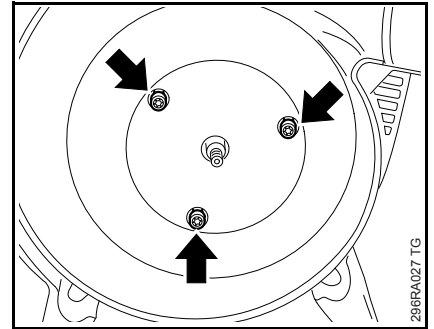

- Position the engine on the inner fan housing – the holes in the engine and fan housing must be in alignment.
- Insert the screws (arrows) and tighten them down firmly.
- Install the blower wheel, [11.2](#)

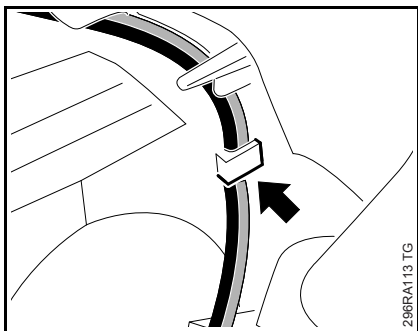

Fit the short circuit and ground wires in the retainers (arrow).

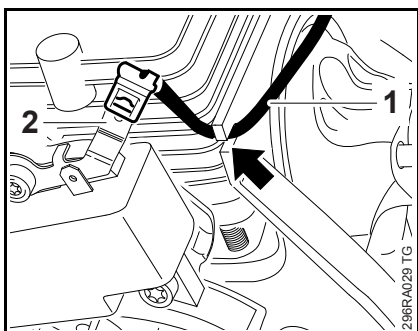

- Attach the ground wire (1) to the guide (arrow) and push it firmly onto the connector tag (2).

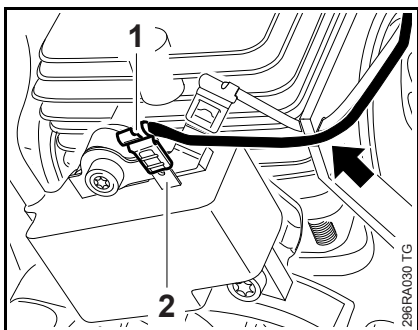

- Attach the short circuit wire (1) to the guide (arrow) and push it firmly onto the ignition module's connector tag (2).
- Install the throttle rod, 10.6

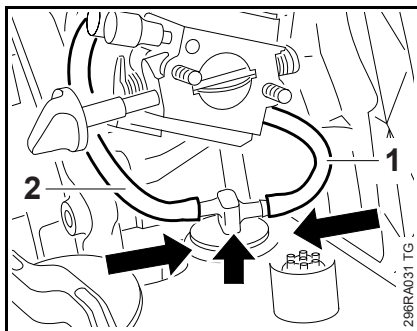

- Push the fuel suction hose (1) and fuel return hose (2) onto the stubs (arrows) on the connector.
- Install the air filter, 10.1
- Reassemble all other parts in the reverse sequence.
- Tightening torques, 3.4

5.5 Cylinder Removing and Installing

Before removing the cylinder, decide whether or not the crankshaft has to be removed as well.

Cylinder installed

To remove the flywheel, the crankshaft has to be blocked by inserting the locking strip in the spark plug hole.

Cylinder removed

To remove the flywheel, the crankshaft has to be blocked by resting the piston on the wooden assembly block.

Remove the engine, 5.4

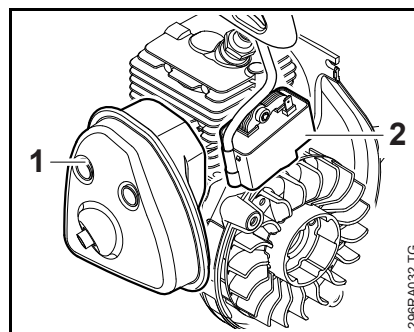

- Remove the muffler (1), 5.1
- Remove the ignition module (2), 6.1.1
- Remove the flywheel (3), 6.5

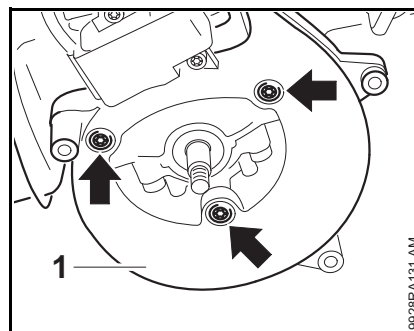

- Take out the screws (arrows).
- Remove the spiral housing (1).

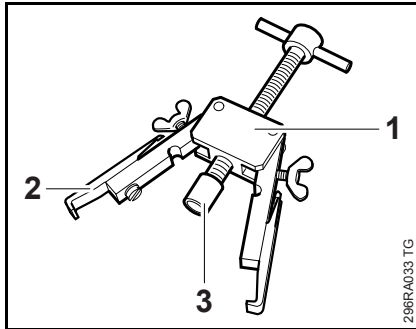

298RA033 TG

- Prepare the puller (1) 5910 890 4400.
- Fit the No. 2 jaws (2) 0000 893 3700.
- Screw the bushing (3) 1108 893 4500 onto the puller's spindle.

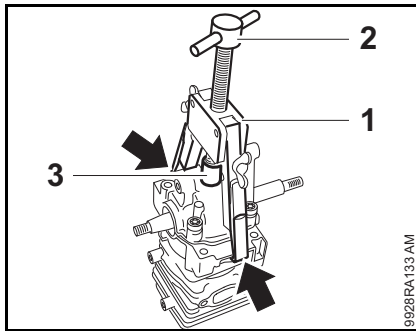

9928RA133 AM

- Apply the puller (1) 5910 890 4400 with the jaws under the crankcase ribs (arrows) and line up the spindle (2) so that the bushing (3) is centered on the engine pan.
- Turn the spindle clockwise until the puller sits tightly.

Do not overtighten the spindle because the jaws may slip off or damage the crankcase ribs.

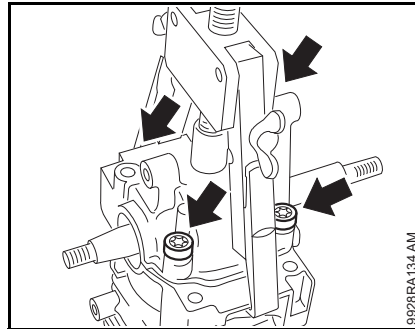

9928RA134 AM

- Take out the cylinder screws (arrows).

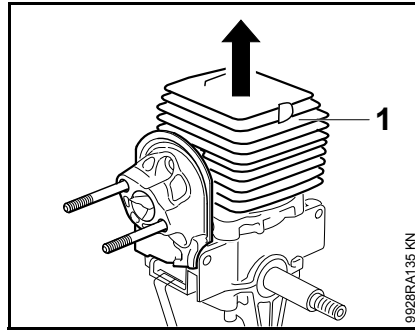

9928RA135 KN

- Carefully lift the cylinder (1) away.

Do not use pointed or sharp-edged tools for this job.

- Check the cylinder and replace if necessary

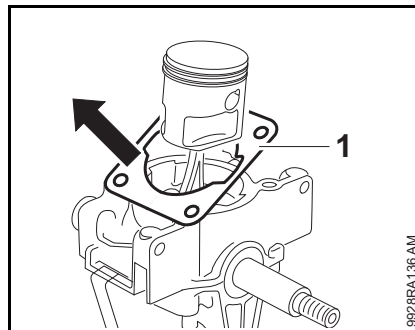

9928RA136 AM

- Remove the cylinder gasket (1).

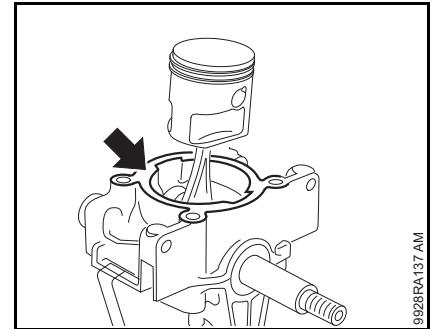

9928RA137 AM

- Inspect and clean the sealing face (arrow), 13

The sealing face must be in perfect condition. Always replace components with damaged sealing faces, 4.5.

Installing

Always use a new cylinder gasket when re-installing the cylinder.

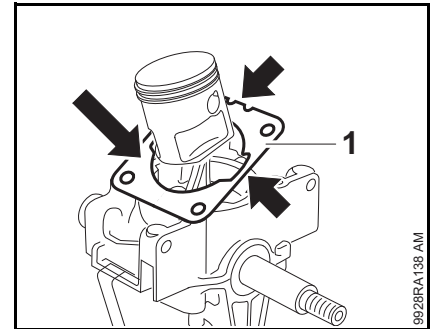

9928RA138 AM

- Line up the cylinder gasket (1) so that the tab and cutouts (arrows) match the contours of the crankcase.

- Place the cylinder gasket (1) in position.

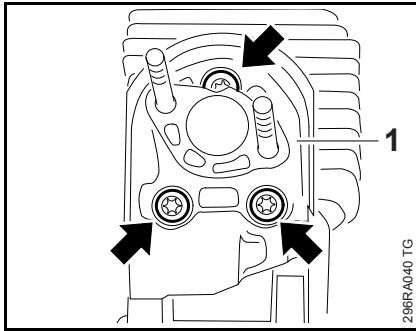

- Inspect the spacer flange (1) and replace it if necessary – even very minor damage can result in engine running problems, 4.5

In a new cylinder is installed, the spacer flange must be transferred from the old cylinder.

- Take out the screws (arrows).
- Remove the spacer flange (1).

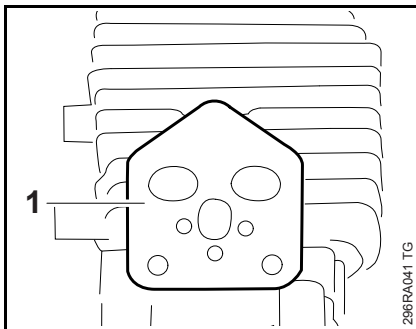

- Remove the gasket (1).

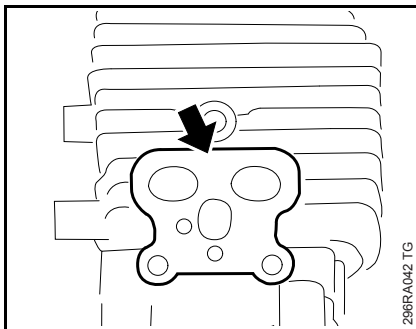

- Inspect and clean the sealing face (arrow) and remove any gasket residue, 13

- Check the sealing faces on the cylinder intake and exhaust ports.

The sealing faces must be in perfect condition. If the sealing faces are damaged, install a new cylinder.

- Inspect the piston and piston rings and replace if necessary, 5.8

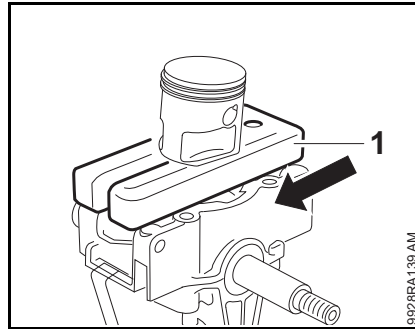

- Slide the wooden assembly block (1) 1108 893 4800 between the piston and crankcase.

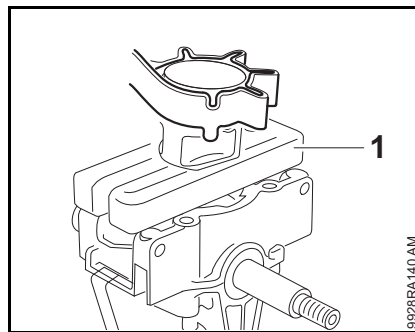

- Lubricate the piston, piston rings and cylinder wall with oil, 13

- Use the clamping strap (1) 0000 893 2600 to compress the rings around the piston.

- Check correct installed position of rings, 5.8.2

Apply the clamping strap (1) so that the piston rings do not project beyond the cylinder wall.

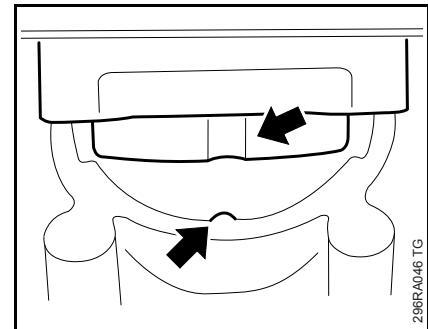

- Align the cylinder so that the recess in the cylinder engages the lug on the crankcase (arrows).

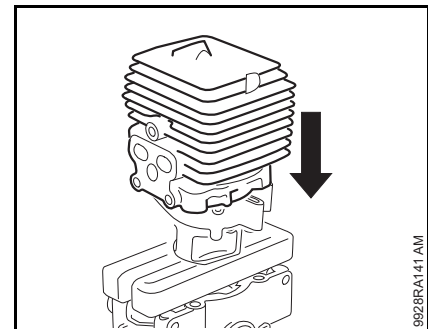

While sliding the cylinder over the piston, hold the clamping strap tightly around the piston so that the rings do not project – they might otherwise break.

- Slide the cylinder over the piston, the clamping strap moves downwards at the same time.

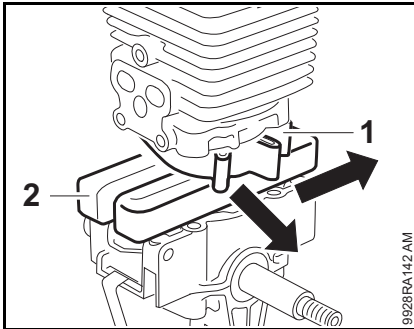

- Remove the clamping strap (1) and wooden assembly block (2).

Make sure the cylinder gasket is properly seated.

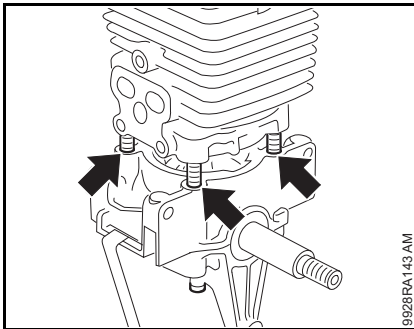

- Push the cylinder fully home.
- Insert the screws (arrows) to hold the cylinder and gasket in position..
- Tighten down the screws firmly in a crosswise pattern.
- Tightening torques, 3.4
- Remove the puller.
- Install the spacer flange, 10.7
- Install the muffler, 5.1
- Install the ignition module, 6.1.1
- Reassemble all other parts in the reverse sequence.

5.6 Crankshaft

5.6.1 Removing and Installing

- Remove the engine, 5.4

The puller is not necessary for removal of the crankshaft.

- Remove the flywheel, 6.5
- Remove the cylinder, 5.5
- Remove the piston, 5.8

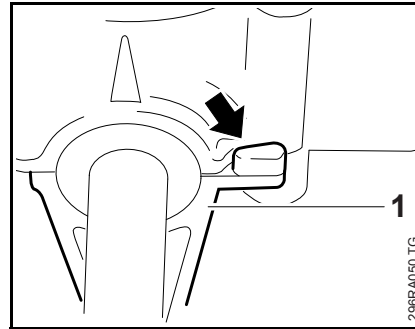

- Loosen the engine pan (1) at the lug (arrow).
- Remove the engine pan.

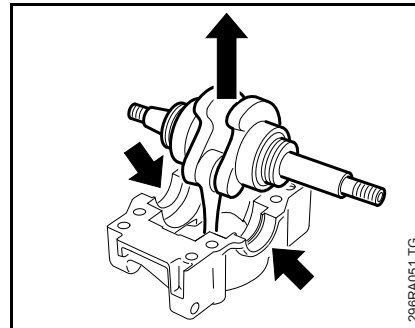

- Release the crankshaft from the bearing seats (arrows) and take it out of the crankcase.

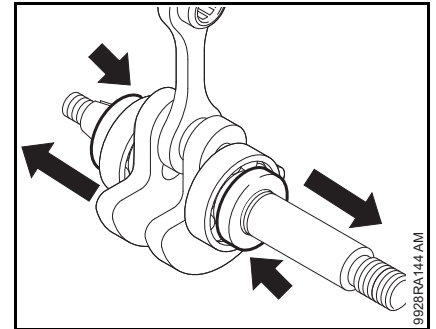

- Pull the oil seals (arrows) off the crankshaft stubs.
- Check the crankshaft and ball bearings and replace if necessary, 5.6.1

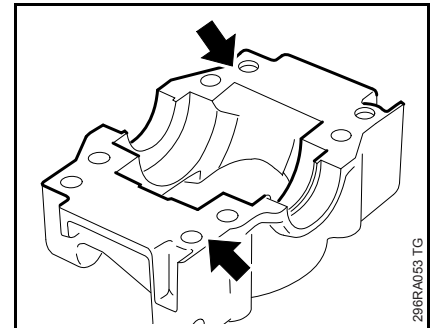

- Inspect the crankcase and sealing faces (arrows) for the engine pan and cylinder, clean and remove gasket residue if necessary, 13

The sealing faces must be clean and in perfect condition. Always replace components with damaged sealing faces.

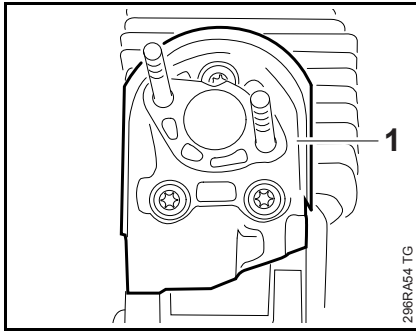

296RA54 TG

- Check the spacer flange (1) and replace if necessary, 10.7

In a new cylinder is installed, the spacer flange must be transferred from the old cylinder – always install a new gasket, 10.7.

Installing

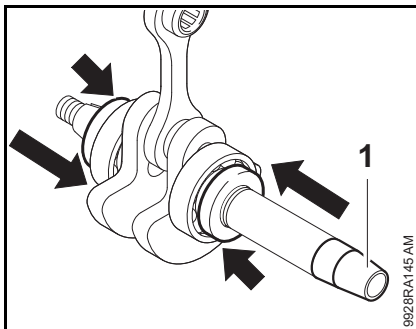

892BRA145 AM

- Fit the installing sleeve (1) 4119 893 4600.
- Push the new oil seals, open side facing the ball bearings (arrows), on to the crankshaft stubs.

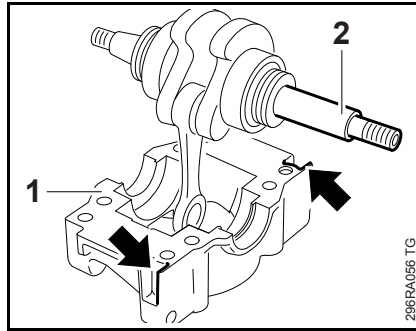

296RA066 TG

- Position the crankcase (1) so that the bearing seats face up.
- Before fitting the crankshaft in the crankcase, line it up so that the straight stub (2) is at the same side as the recesses (arrows).

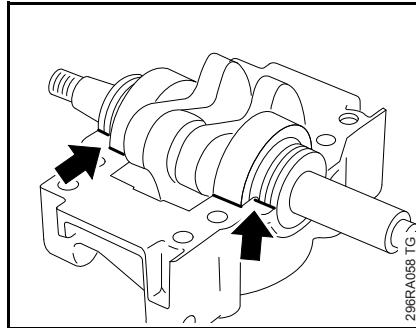

296RA058 TG

- Position the crankshaft, connecting rod first, in the crankcase.
- Place the crankshaft with bearings and oil seals in the crankcase, making sure the oil seals are properly seated against the stops (arrows).

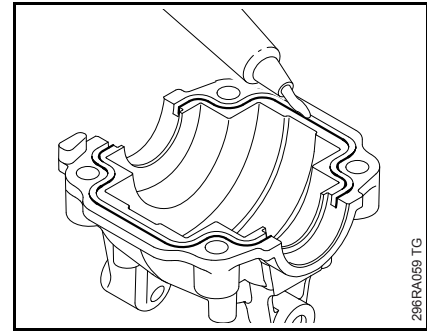

296RA069 TG

- Inspect and clean the sealing faces on the engine pan and remove any gasket residue, 13

The sealing faces must be clean and in perfect condition. Always replace components with damaged sealing faces.

- Apply sealant to the groove in the sealing face, 13

Make sure the sealant does not project into the engine pan.

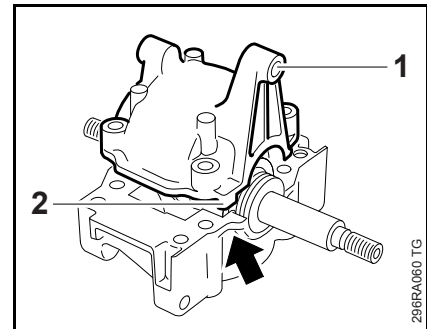

296RA060 TG

- Line up the engine pan (1) so that the lug (2) is on the same side as the crankcase contour (arrow).
- Place the engine pan (1) on the crankcase sealing face.

Press the engine pan carefully into position so that the sealant is evenly distributed.

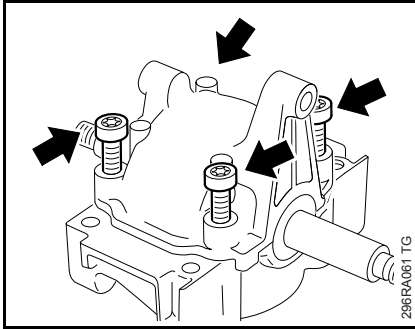

- Insert the cylinder base screws in the holes (arrows) to hold the engine pan in position.

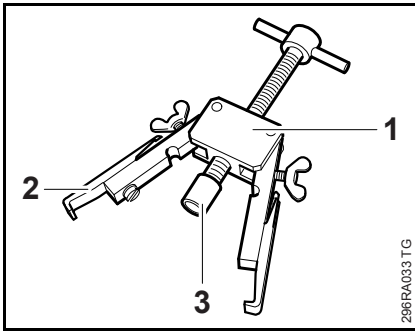

- Prepare the puller (1) 5910 890 4400.
- Fit the No. 2 jaws (2) 0000 893 3700.
- Screw the bushing (3) 1108 893 4500 onto the puller's spindle.

Take care not to damage the crankshaft stubs.

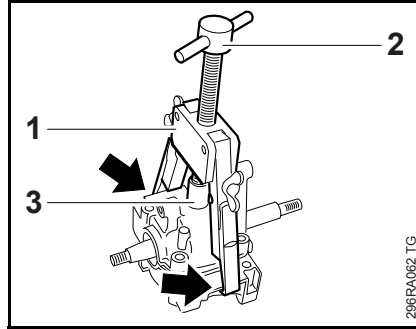

- Apply the puller (1) 5910 890 4400 with the jaws under the crankcase ribs (arrows) and line up the spindle (2) so that the bushing (3) is centered on the engine pan.
- Turn the spindle clockwise until the puller sits tightly.

Do not overtighten the spindle because the jaws may slip off or damage the crankcase ribs.

- Clean the crankshaft stubs, 13
- Install the piston, 5.8
- Install the cylinder, 5.5
- Remove the puller.
- Install the engine, 5.4
- Reassemble all other parts in the reverse sequence.

5.7 Bearings / Crankshaft

- Remove the crankshaft, 5.6
- Pull off the oil seals, 5.6.1

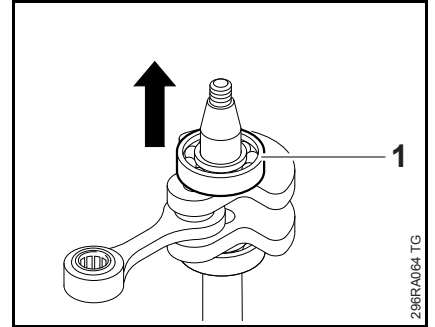

- Pull the ball bearing (1) off the tapered crankshaft stub.

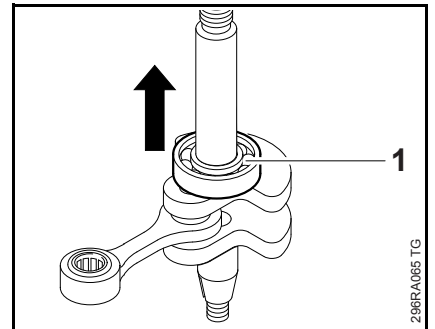

- Pull the ball bearing (1) off the straight crankshaft stub.

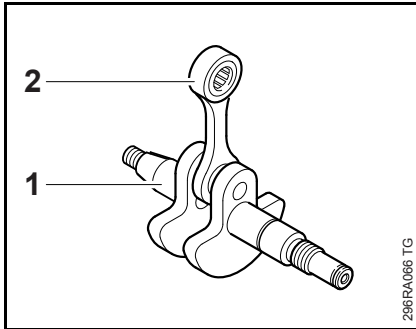

298RA066 TG

- The crankshaft (1), connecting rod (2) and needle bearing form an inseparable unit. It must always be replaced as a complete unit.

When fitting a replacement crankshaft, always install new ball bearings and oil seals.

- Before installing, clean the crankshaft, [13](#)

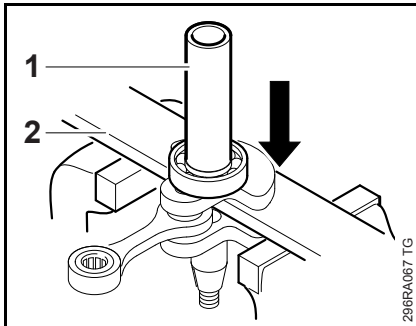

298RA067 TG

Use a firm base (2) to protect the crankshaft.

- Apply a suitable sleeve (1) to the inner race of the ball bearing at the blower side and press it home as far as stop.

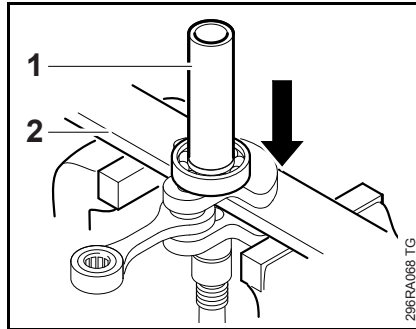

298RA068 TG

Use a firm base (2) to protect the crankshaft.

- Apply a suitable sleeve (1) to the inner race of the ball bearing at the ignition side and press it home as far as stop.

- Lubricate the needle bearing with oil.
- Install the piston, [5.8](#)
- Fit new oil seals and install the crankshaft, [5.6.1](#)
- Install the engine, [5.4](#)
- Tightening torques, [3.4](#)
- Reassemble all other parts in the reverse sequence.

5.8 Piston

- Remove the engine, [5.4](#)
- Remove the cylinder, [5.5](#)

The piston has only one snap ring. It is fitted at the blower side (straight crankshaft stub).

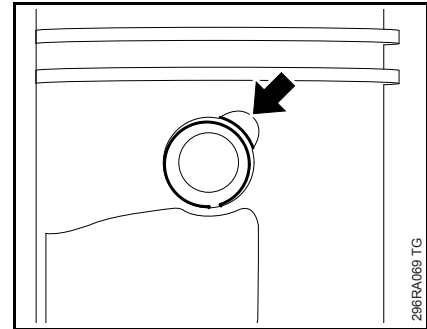

298RA069 TG

- Use a suitable tool to grip the hookless snap ring at the recess (arrow) and ease it out.

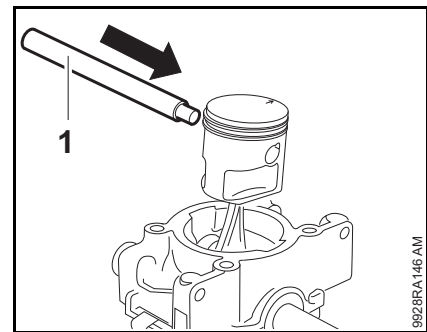

9928RA146 AM

- Apply assembly drift (1) 1130 893 4700, small diameter first, to the ignition side of the piston.

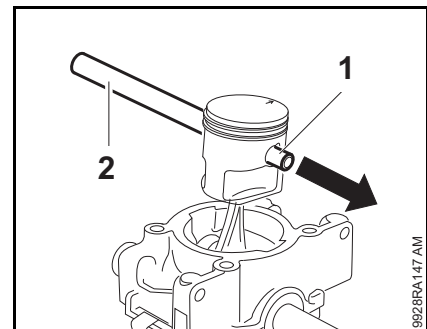

9928RA147 AM

- Use the assembly drift (2) 1130 893 4700 to push the piston pin (1) out of the piston.

If the piston pin is stuck, release it by tapping the end of the drift lightly with a hammer.

Hold the piston steady during this process to ensure that no jolts are transmitted to the connecting rod.

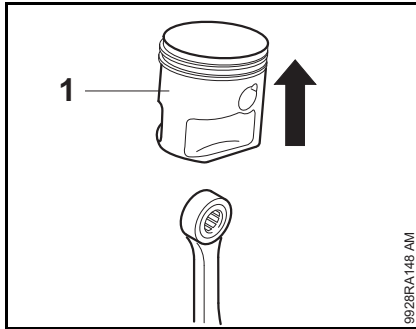

- Remove the piston (1) from the connecting rod.
- Inspect the piston and replace it if necessary.
- Inspect the piston rings and replace if necessary, 5.8.2

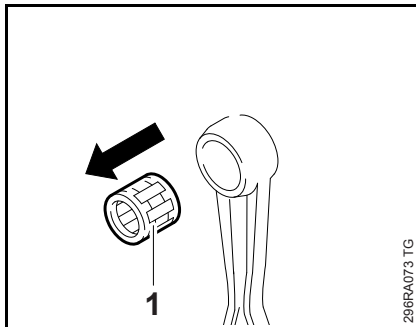

- Pull out the needle cage (1), check it and replace if necessary, 13
- Lubricate the needle cage with oil and push it into the connecting rod.

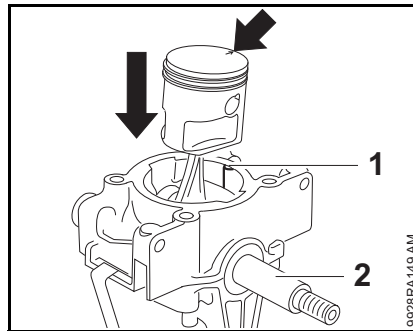

- Line up the piston as shown so that the arrow (arrow) on the piston crown faces the crankcase lug (1) and the straight crankshaft stub (2) is on the right.
- Place the piston on the connecting rod.

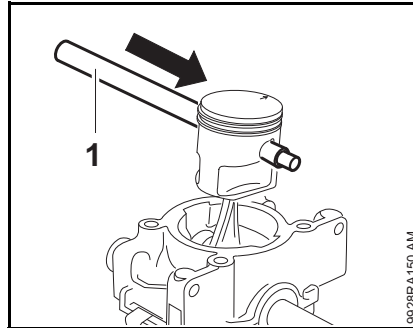

- Push the assembly drift (1) 1130 893 4700, small diameter first, through the piston and small end (needle cage).

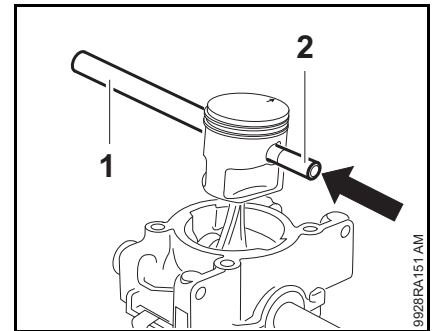

- Fit the piston pin (2) on the assembly drift (1) and slide it into the piston.

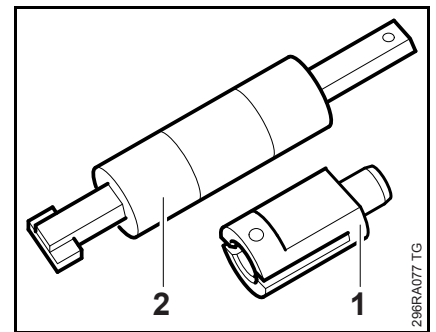

- Remove the sleeve (1) 5910 893 1708 from the installing tool (2) 5910 890 2208.

The previous sleeve (1) 5910 893 1703 may also be used. The new sleeve (1) 5910 893 1708 has a 20° chamfer for better security in the piston bore.

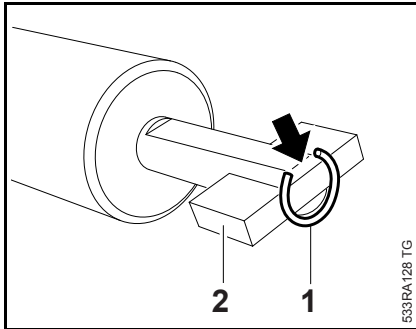

- Attach the snap ring (1) to the magnet (2) so that the ring gap is on the flat side of the tool's shank (arrow).

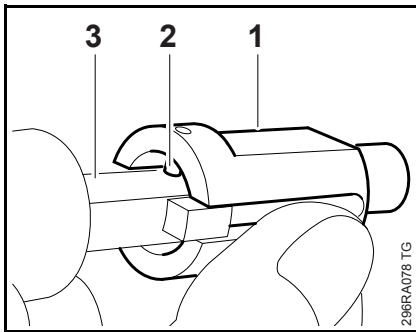

- Push the slotted diameter of the sleeve (1) 5910 893 1708 over the magnet and snap ring.

The inner pin (2) must point towards the flat face (3) of the tool's shank.

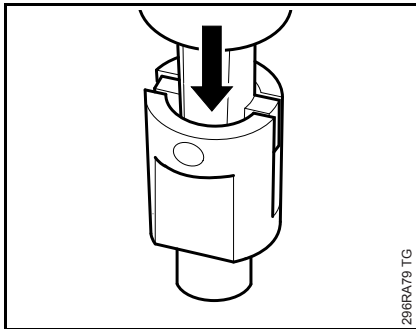

- Press the installing tool downwards into the sleeve until the magnet butts against the end of the guide slot.

Use a suitable base (wooden board).

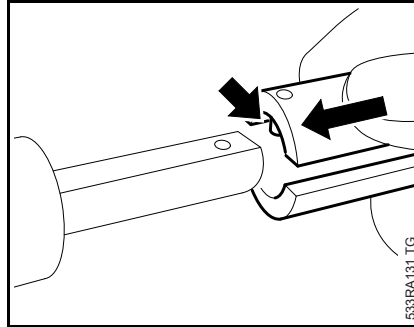

- Remove the sleeve and push it on to the other end of the shank as far as stop.

The inner pin (arrow) must again point toward the flat face.

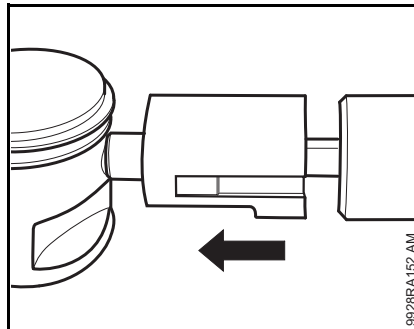

- Install the snap ring at the blower side of the piston.

- Apply the installing tool 5910 890 2208 with the sleeve's taper against the piston boss, hold the piston steady, center the tool shank exactly and press home until the snap ring slips into the groove.

Make sure the tool is held square on the piston pin axis.

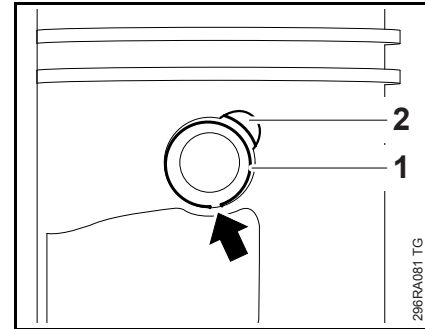

Fit the snap ring (1) so that its gap (arrow) points down – it must not be near the recess (2).

- Check installed position of snap ring.

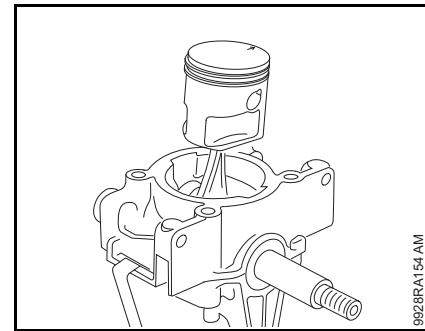

- Inspect the piston rings and replace if necessary, [5.8.2](#)
- Install the cylinder, [5.5](#)
- Install the engine, [5.4](#)
- Tightening torques, [3.4](#)
- Reassemble all other parts in the reverse sequence.

5.8.1 Piston Rings

- Remove the piston,  5.8
- Remove the piston rings from the piston.

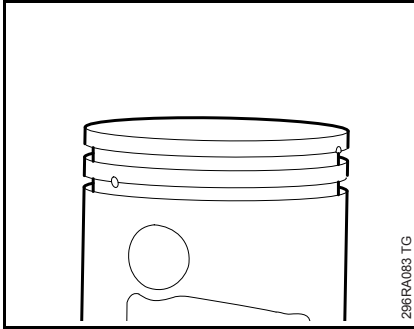

- Use a piece of old piston ring to scrape the grooves clean.

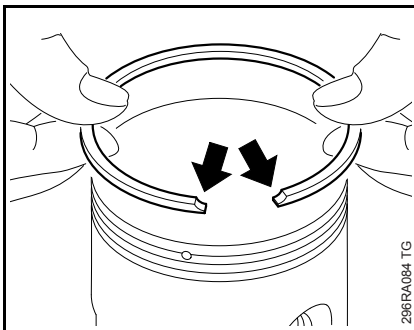

- Position the new piston rings in the groove so that the radii (arrows) at the ring gaps face upwards.

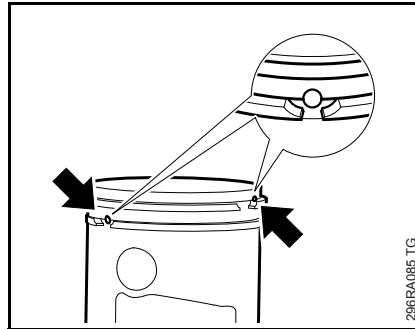

- Position the piston rings so that the radii at the ring gap meet at the fixing pin in the piston groove (arrows).

- Install the piston,  5.8

5.8.2 Piston Rings

- Remove the piston,  5.8
- Remove the piston rings from the piston.

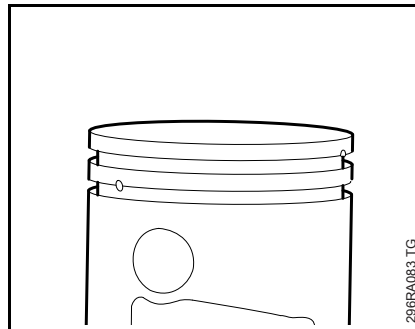

- Use a piece of old piston ring to scrape the grooves clean.

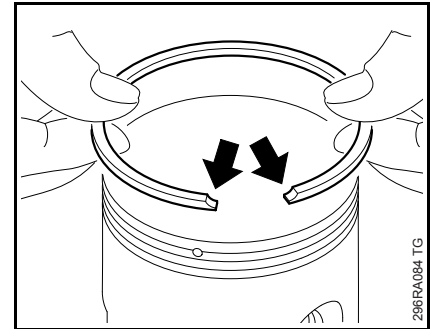

- Position the new piston rings in the groove so that the radii (arrows) at the ring gaps face upwards.

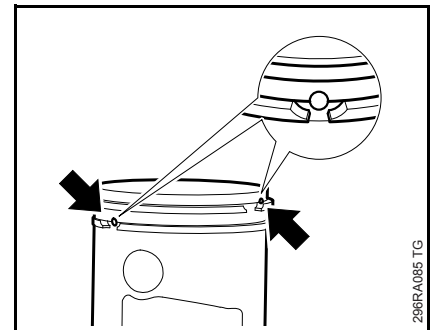



- Position the piston rings so that the radii at the ring gap meet at the fixing pin in the piston groove (arrows).

- Check correct installed position of the piston rings (arrows).
- Install the piston,  5.8

6. Ignition System

Exercise extreme caution when troubleshooting and carrying out maintenance or repair work on the ignition system. The high voltages which occur can cause serious or fatal accidents.

Troubleshooting on the ignition system should always begin at the spark plug,  4.3

- Remove the fan housing,  7.2

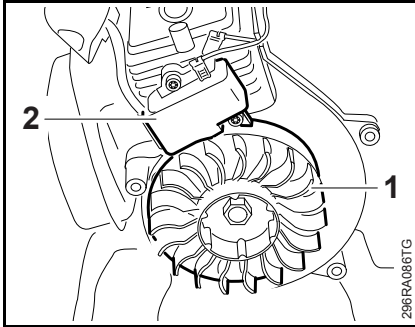

The electronic (breakerless) ignition system basically consists of an ignition module (2) and flywheel (1).

6.1 Ignition Module

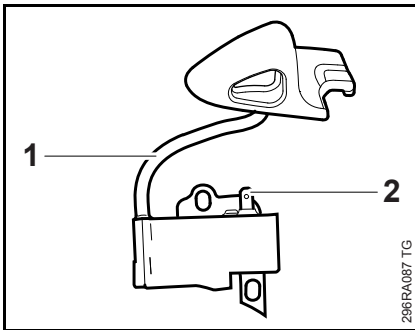

The ignition module accommodates all the components required to control ignition timing. There are two electrical connections on the coil body:

- High voltage output (1) with ignition lead
- Connector tag (2) for the short circuit wire

Testing in the workshop is limited to a spark test. A new ignition module must be installed if no ignition spark is obtained (after checking that wiring and stop switch are in good condition),  6.1.1.

Ignition timing is fixed and cannot be adjusted during repair work.

Since there is no mechanical wear in these systems, ignition timing cannot get out of adjustment during operation.

6.1.1 Removing and Installing

- Remove the fan housing,  7.2

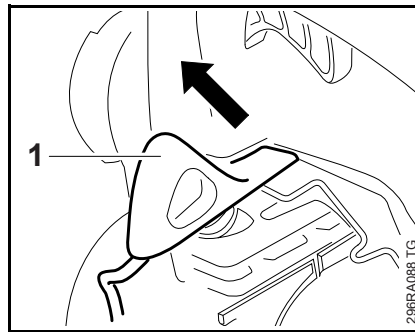

- Pull boot (1) off the spark plug.

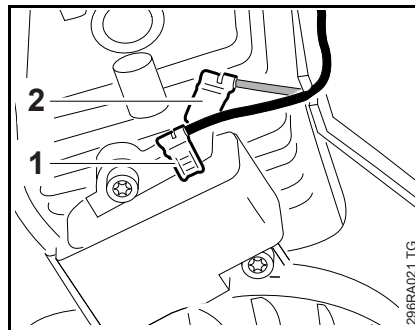

- Disconnect the short circuit wire (1) and ground wire (2).

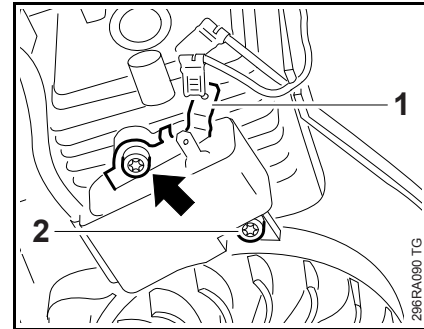

- Take out the screw (arrow).
- Remove the connector tag (1).
- Take out the screw (2) and washer.

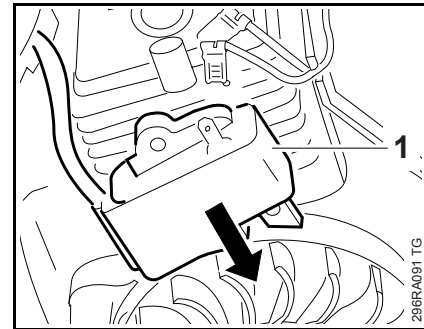

- Remove the ignition module (1).

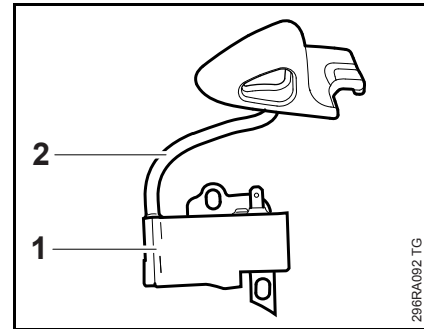

The ignition module (1) and ignition lead (2) form a unit.

- Check the ignition module (1) and replace if necessary

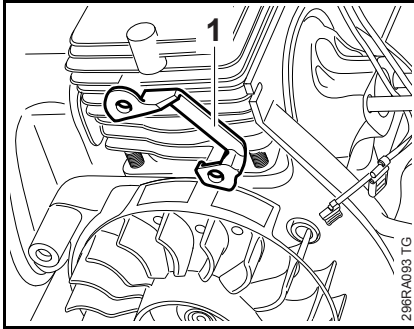

- Remove the insulator (1).
- Check the insulator and replace if necessary.
- Check the spark plug boot and replace if necessary, [§ 6.4](#)
- Troubleshooting, [§ 4.3](#)

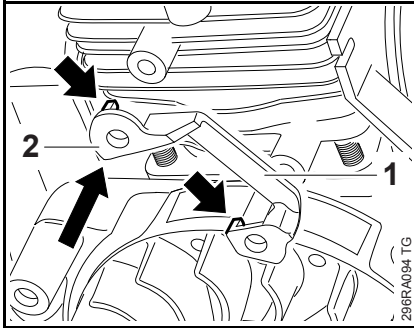

- Position the insulator (1) so that the connecting bar (2) points towards the carburetor.
- Attach the lugs (arrows) of the insulator (1) to the bosses.

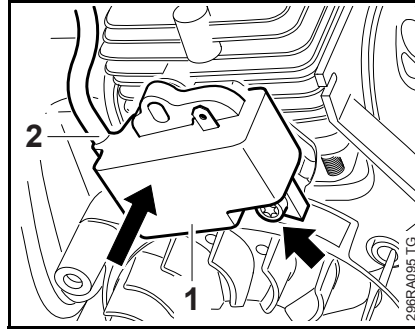

- Place the ignition module (1) in position so that the ignition lead (2) faces the muffler and insert the screw (arrow) with washer – do not tighten down yet.

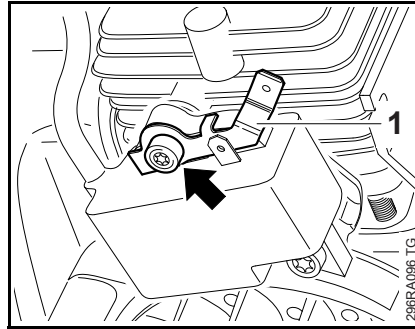

- Fit the connector tag (1) and insert the screw (arrow) – do not tighten down yet.

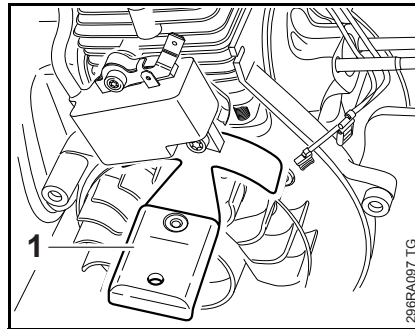

- Push the ignition module (1) back
- Slide the setting gauge (1) 1127 890 6400 between the arms of the ignition module and the flywheel magnet.

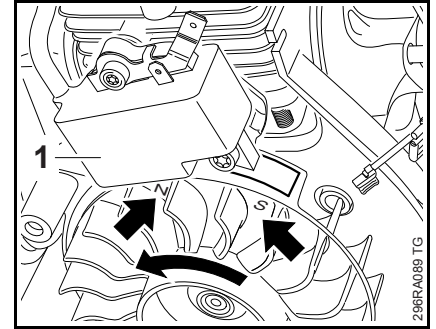

- Push the ignition module (1) back
- the flywheel must turn freely.

The setting gauge is not shown in the illustration.

- Hold the setting gauge and rotate the flywheel until the magnet poles (arrows) are next to the ignition module.

- Press the ignition module against the setting gauge.
- Tighten down the screws firmly.
- Tightening torques, [§ 3.4](#)
- Remove the setting gauge.
- Check operation – rotate the flywheel and make sure it does not touch the ignition module.

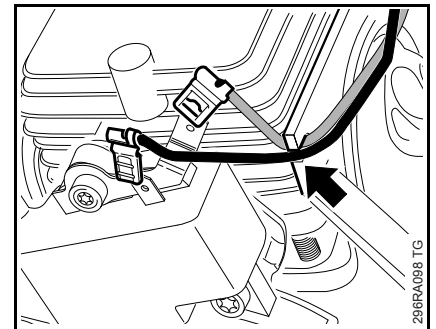

- Fit the ground wire (wide flag terminal) and then the short circuit wire (narrow flag terminal) in the guide (arrow).

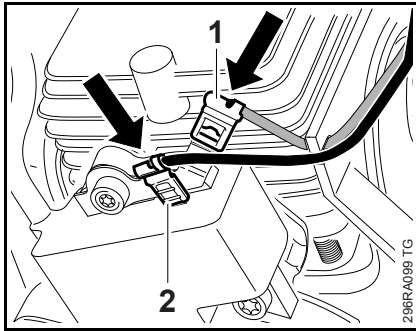

- Connect the ground wire (1) and short circuit wire (2).

- Push the boot onto the spark plug.
- Reassemble all other parts in the reverse sequence.

6.2 Ignition Timing

Ignition timing is fixed and cannot be adjusted during repair work.

Since there is no mechanical wear in these systems, ignition timing cannot get out of adjustment during operation.

6.3 Testing the Ignition Module

To test the ignition module, use either the ZAT 4 ignition system tester 5910 850 4503 or the ZAT 3 ignition system tester 5910 850 4520.

The ignition test refers only to a spark test, not to ignition timing.

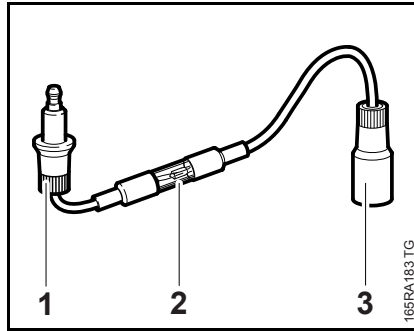

Using the ZAT 4 ignition tester 5910 850 4503

- Before starting the test, install a new spark plug in the cylinder and tighten it down firmly.
- Tightening torques, 3.4
- Connect spark plug boot to the input terminal (1). Push the tester's output terminal (3) on to the spark plug.

High voltage – risk of electric shock.

- Crank the engine quickly with the rewind starter and check spark in the tester's window (2).

The engine may start and accelerate during the test.

If a spark is visible, the ignition system is in order.

If no spark is visible in the window (2), check the ignition system with the aid of the troubleshooting chart, 6.7

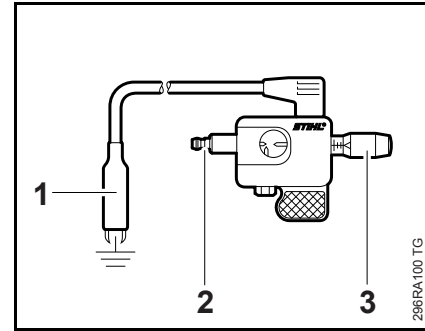

Using the ZAT 3 ignition tester 5910 850 4520

- Before starting the test, install a new spark plug in the cylinder and tighten it down firmly.
- Tightening torques, 3.4
- Connect spark plug boot to the terminal (2).
- Attach the ground terminal (1) to the spark plug.
- Use adjusting knob (3) to set the spark gap to about 2 mm.

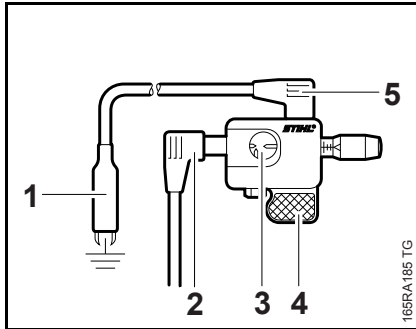

While using the ZAT 3, hold it only by the handle (4) or position it in a safe place. Keep fingers or other parts of your body at least 1 cm away from the spark window (3), high voltage connection (2), ground connection (5) and the ground terminal (1).

High voltage – risk of electric shock.

- Crank the engine quickly with the rewind starter and check spark in the tester's window (3).

The engine may start and accelerate during the test.

If a spark is visible, the ignition system is in order.

If no spark is visible in the window (3), check the ignition system with the aid of the troubleshooting chart, 6.7

6.4 Spark Plug Boot

The ignition module (1) and ignition lead (2) form a unit. A new ignition module must be installed if the ignition lead is damaged.

- Remove the fan housing, 7.2
- Pull the boot off the spark plug.

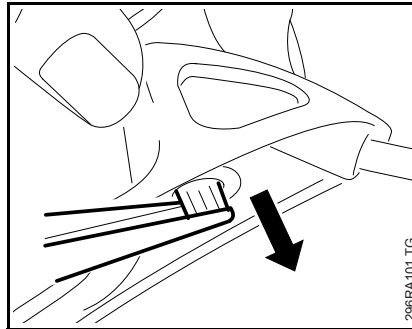

- Use suitable pliers to pull the leg spring out of the spark plug boot.
- Unhook the leg spring from the ignition lead.
- Pull the boot off the ignition lead.

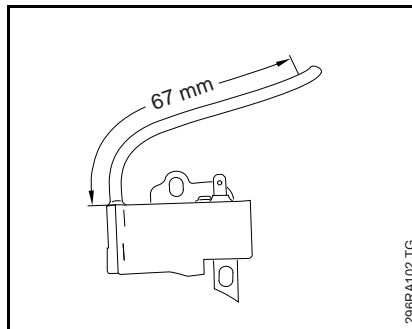

- Use a pointed tool to pierce the center of the new ignition lead's insulation, about 67 mm from the end of the lead.

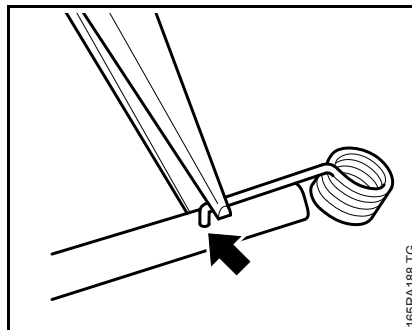

- Pinch the hook of the leg spring into the center of the lead (arrow).

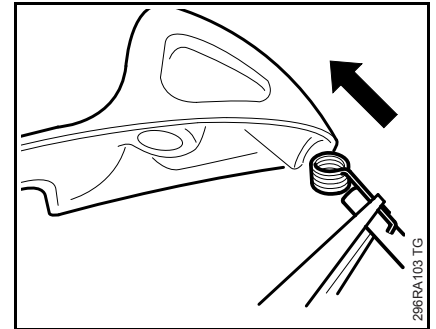

- Coat inside of spark plug boot with STIHL Press Fluid, 13
- Hold the ignition lead and leg spring together and push them into the spark plug boot.

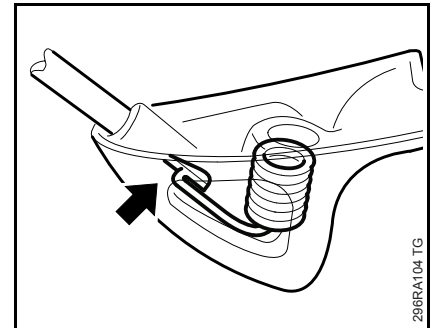

- Make sure the leg spring (arrow) locates properly inside the spark plug boot.

Do not use either graphite grease or silicone insulating paste.

- Reassemble all other parts in the reverse sequence.

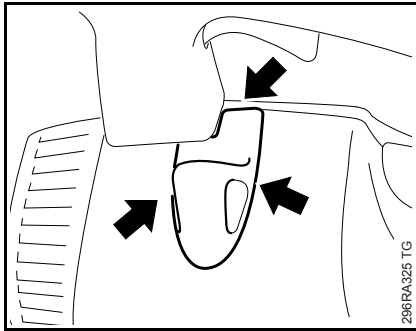

The rubber lip of the spark plug boot must completely seal the opening (arrows) in the fan housing.

6.5 Flywheel

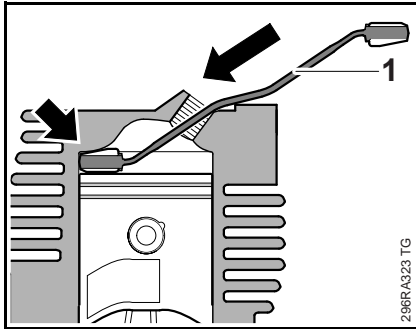

- Remove the fan housing, 7.2
- Unscrew the spark plug.
- Use locking strip (1) to block the piston, 6.5

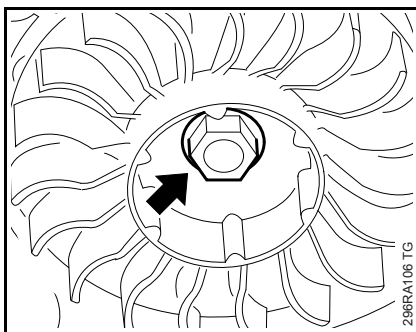

- Unscrew the flywheel nut (arrow).

If the flywheel is stuck, use a puller.

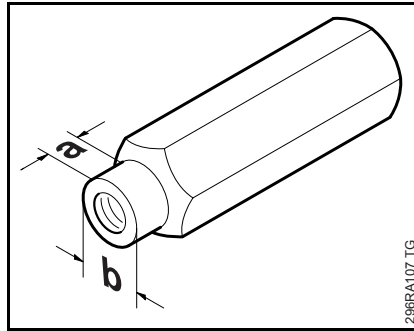

The puller 1116 893 0800 can be modified as shown above – this does not affect its use in other machines.

- Turn the screw end of the puller to a diameter of 'b' = 16 mm and depth of 'a' = 10 mm .

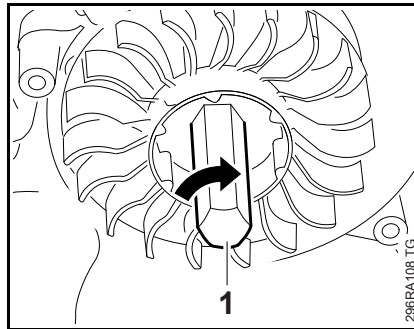

- Screw the puller (1) 5910 893 0801 clockwise on to the crankshaft as far as stop, then back it off a 1/4 turn.
- Tap the end of the puller a few times to release the flywheel – take care not to damage the crankshaft stub or ball bearing.
- Unscrew the puller and remove the flywheel.

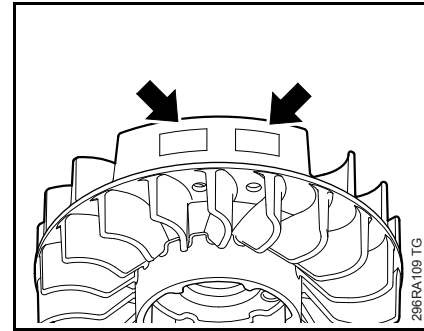

The flywheel and magnet poles (arrows) must not be damaged or have turned blue. Replace flywheel if necessary.

Before assembly, degrease the bore in the flywheel hub and the crankshaft stub, 13.

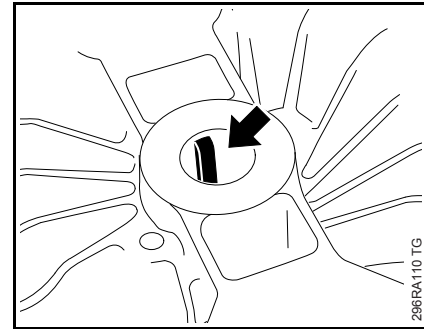

- Make sure the key (arrow) engages the slot in the crankshaft stub.
- Check the air gap between the ignition module and flywheel and adjust if necessary, 6.1.1
- Reassemble all other parts in the reverse sequence.
- Tightening torques, 3.4

6.6 Short Circuit Wire

6.6.1 Testing

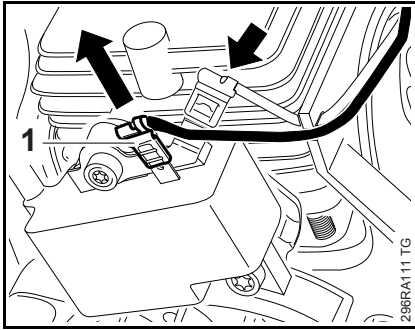

If the spark plug, ignition lead and spark plug boot are in order, check the short circuit wire and stop switch.

- Remove the fan housing, [📖 7.2](#)
- Disconnect the short circuit wire (1).
- Connect the ohmmeter to ground (arrow) and the short circuit wire (1).
- Set the stop switch to "0" and hold it in that position.

The resistance measured must be about 0 Ω. If it is much higher, the reason may be the stop switch or the wire. Damaged parts must be replaced, [📖 6.6.4](#), [📖 6.6.2](#).

- Set the stop switch to "I".

The resistance measured must be infinitely high. If not, fit a new short circuit wire or stop switch, [📖 6.6.2](#), [📖 6.6.4](#).

- To locate the fault, test the wires for continuity and check insulation for damage. If the wires are in order, check operation of stop switch, [📖 6.7](#)
- If no fault can be found, check the ignition system with the aid of the troubleshooting chart, [📖 6.7](#)
- Check ground wire for continuity.
- Reassemble in the reverse sequence.

6.6.2 Removing and Installing

Models SH 56, SH 56 C, BG 56, BG 56 C, BG 66

Separate short circuit and ground wires are installed in these machines and may be replaced individually in case of damage.

Models SH 86, SH 86 C, BG 66 C, BG 86, BG 86 C

Short circuit and ground wires are combined in a wiring harness. The complete wiring must be replaced if either wire is damaged.

When cleaning the machine, make sure wires are not accidentally disconnected.

The short circuit and ground wires are non-interchangeable, i.e. the short circuit wire is equipped with narrow flag terminals (one is insulated) and the ground wire has wide flag terminals (with additional wire at one end).

Removal (all models)

- Remove the fan housing, [📖 7.2](#)
- Remove the throttle rod, [📖 10.6](#)
- Remove the throttle trigger, [📖 9.3](#), [📖 9.4](#)

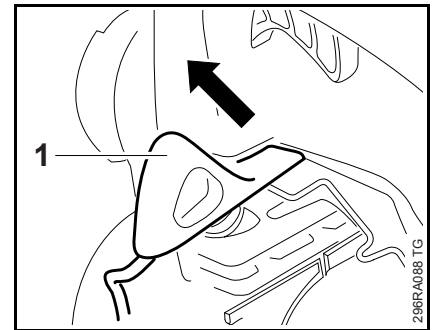

- Pull boot (1) off the spark plug.

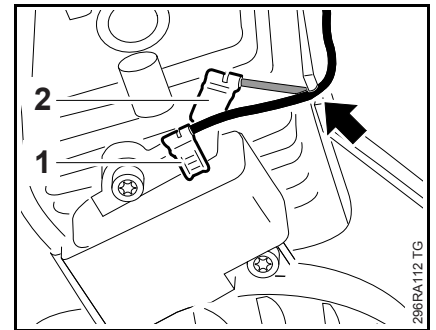

- Disconnect the short circuit wire (1) and ground wire (2).
- Pull the short circuit and ground wires out of the guide (arrow).

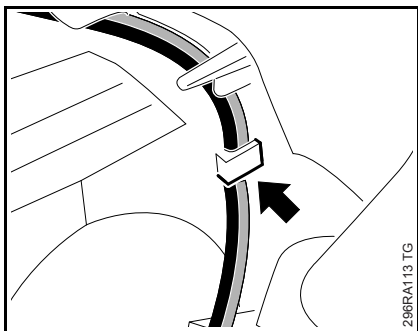

- Pull the wires out of the guides (arrows).

Models SH 56, SH 56 C, BG 56, BG 56 C, BG 66

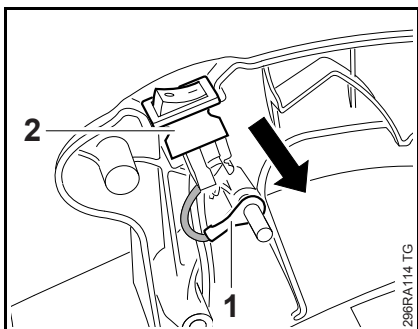

- Pull the ground wire (1) off the pin.
- Pull out the stop switch (2).

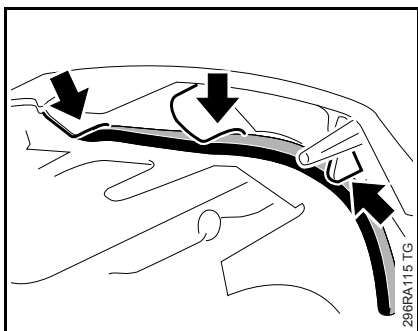

- Pull the ground and short circuit wires out of the guides (arrows).
- Remove the wires with the stop switch.

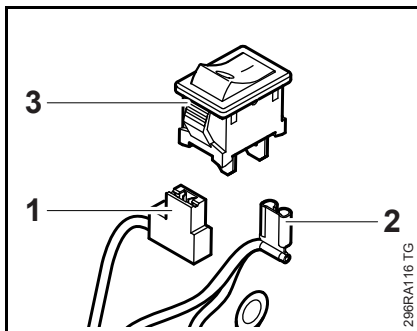

- Disconnect the short circuit wire (1) and ground wire (2) from the stop switch (3).

- Check the individual parts and replace if necessary.

A faulty ground wire may impair or prevent operation of the short circuit wire. The ground wire must therefore be tested for good contact and continuity.

Installing

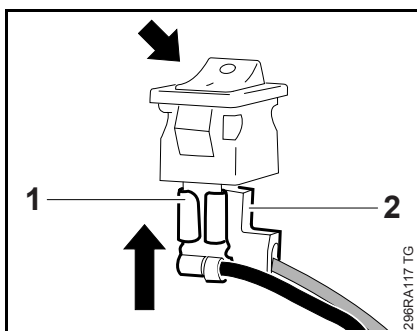

- Push the flag terminals firmly on to the connector tags of the stop switch.

- Fit the short circuit wire (1) with the insulated flag terminal on the narrow connector tag.
- Fit the ground wire (2) with additional wire on the wide connector tag.

The flag terminals must point to the right with the switch in the position shown (small arrow).

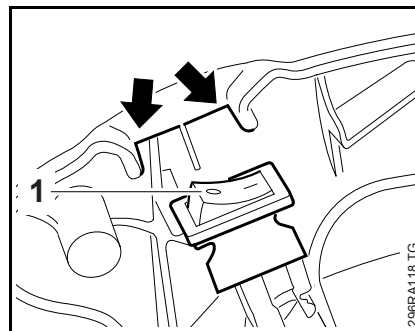

- Position the stop switch (1) so that the "0" on the switch points in the direction of the blower tube.

- Slide the stop switch (1) into the guides (arrows) – the flag terminals must point inside the housing.

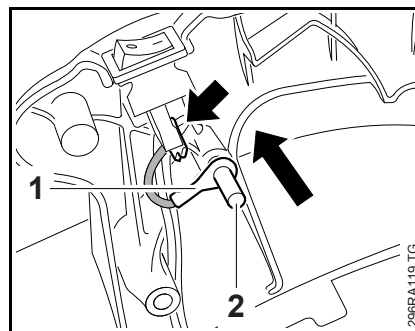

- Push the ground wire terminal (1) on to the pin (2).
- Route the ground wire (1) past the rib (arrow).

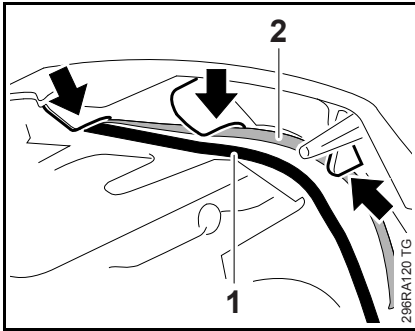

- Push the ground wire (2) into the guides (arrows) first, then the short circuit wire (1).

Position the wires next to one another without crossing over.

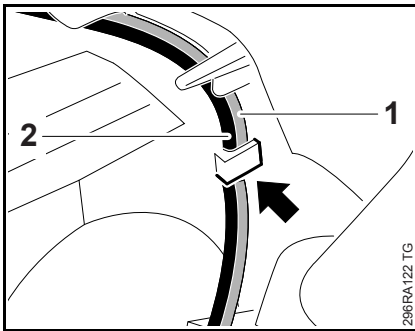

- Fit the short circuit wire (1) and ground wire (2) in the guide (arrow).

Models SH 86, SH 86 C, BG 66 C, BG 86, BG 86 C

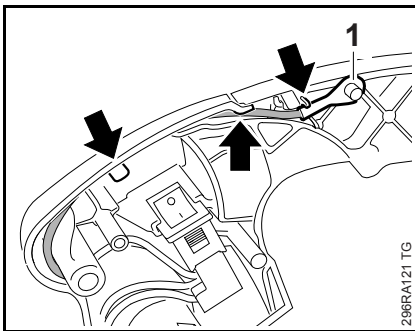

- Pull the ground wire (1) off the pin.
- Pull the ground wire (1) out of the guides (arrows).

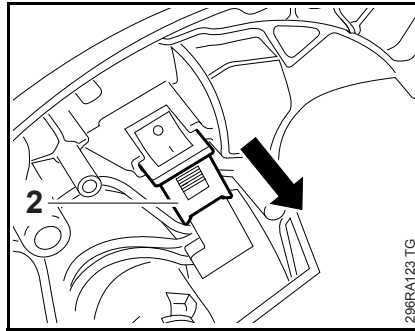

- Pull out the stop switch (1).

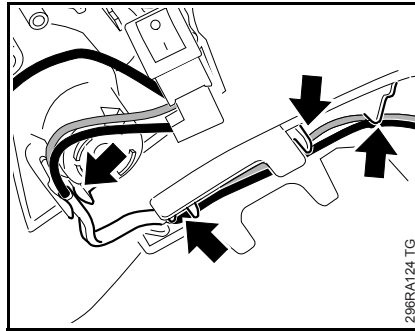

- Pull the wiring harness out of the guides (arrows).
- Remove the wiring harness with the stop switch.

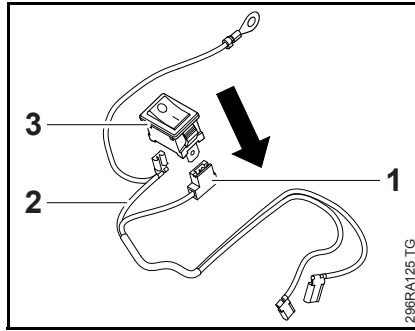

- Disconnect the short circuit wire (1) and ground wire (2) from the stop switch (3).
- Check the wiring harness and stop switch and replace if necessary.

A faulty ground wire may impair or prevent operation of the short circuit wire. The ground wire must therefore be tested for good contact and continuity.

Installing

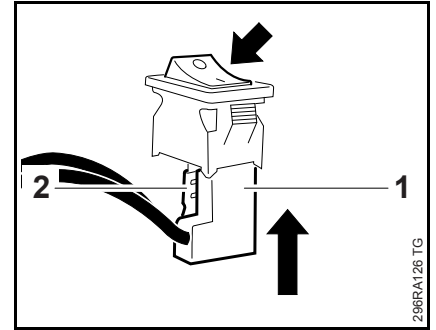

- Push the flag terminals firmly on to the connector tags of the stop switch.
- Fit the short circuit wire (1) with the insulated flag terminal on the narrow connector tag.
- Fit the ground wire (2) with additional wire on the wide connector tag.

The flag terminals must point to the left with the switch in the position shown (small arrow).

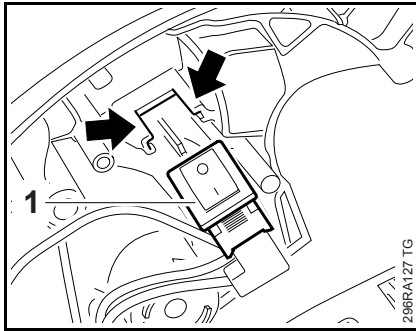

- Position the stop switch (1) so that the "0" on the switch points towards the inside of the housing.
- Slide the stop switch (1) into the guides (arrows) – the flag terminals must point in the direction of the blower tube.

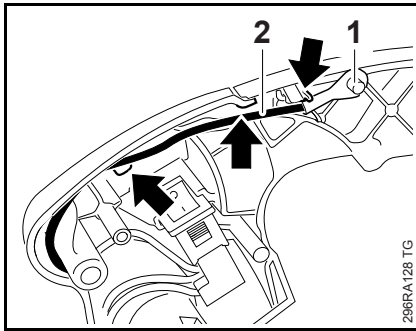

- Push the ground wire terminal (1) on to the pin (2).
- Push the ground wire (1) into the guides (arrows).

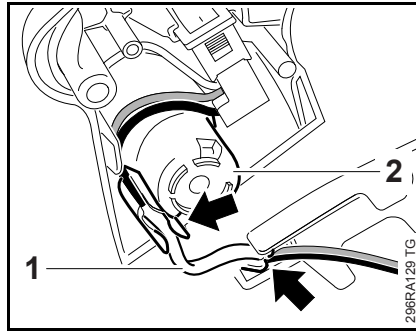

- Lay the wiring harness over the dome (2) of the spring mount.
- Push the protective tube (1) of wiring harness into the retainers (arrows).

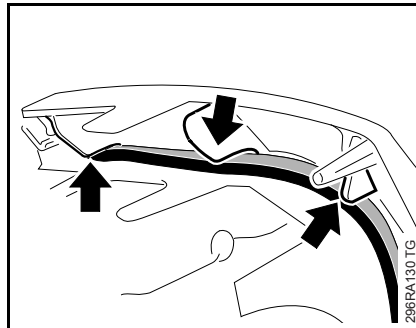

- Push the wiring harness, ground wire first, into the guides (arrows).

Position the wires next to one another without crossing over.

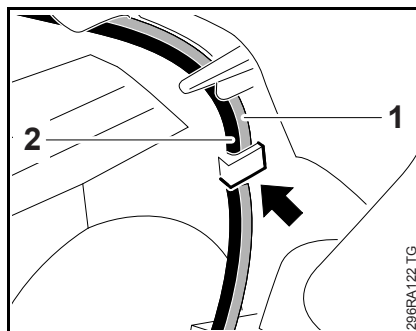

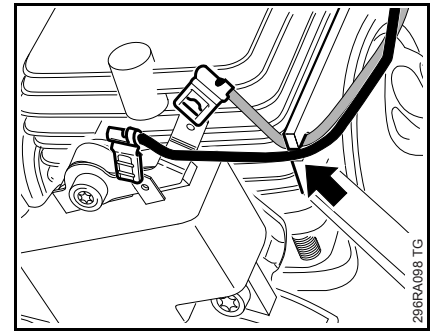

- Fit the short circuit wire (1) and ground wire (2) in the guide (arrow).

All Models

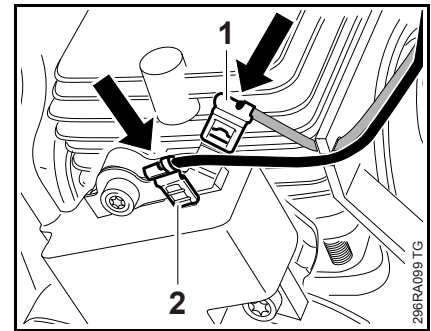

- Fit the ground wire (wide flag terminal) and then the short circuit wire (narrow flag terminal) in the guide (arrow).



- Connect the ground wire (1) and short circuit wire (2).
- Reassemble all other parts in the reverse sequence.
- Tightening torques,  3.4

6.6.3 Ground Wire



A faulty ground wire may impair or prevent operation of the short circuit wire.

Models SH 56, SH 56 C, BG 56, BG 56 C, BG 66

Separate short circuit and ground wires are installed. The ground wire must be replaced if it is damaged.

Models SH 86, SH 86 C, BG 66 C, BG 86, BG 86 C

Short circuit and ground wires are combined in a wiring harness. The complete wiring must be replaced if either wire is damaged.

- Check for contact and continuity and replace the wiring harness if necessary,  6.6.1
- Remove and install the wires or wiring harness,  6.6.2

6.6.4 Stop Switch

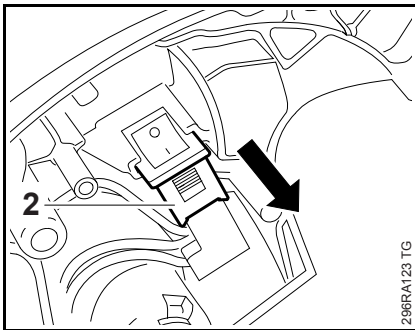

- Remove the stop switch (2),  6.6.2
- Test the stop switch and replace if necessary
- Set the stop switch to "0" = connection
- Set the stop switch to "I" = no connection
- Reassemble in the reverse sequence.

6.7 Ignition System Troubleshooting

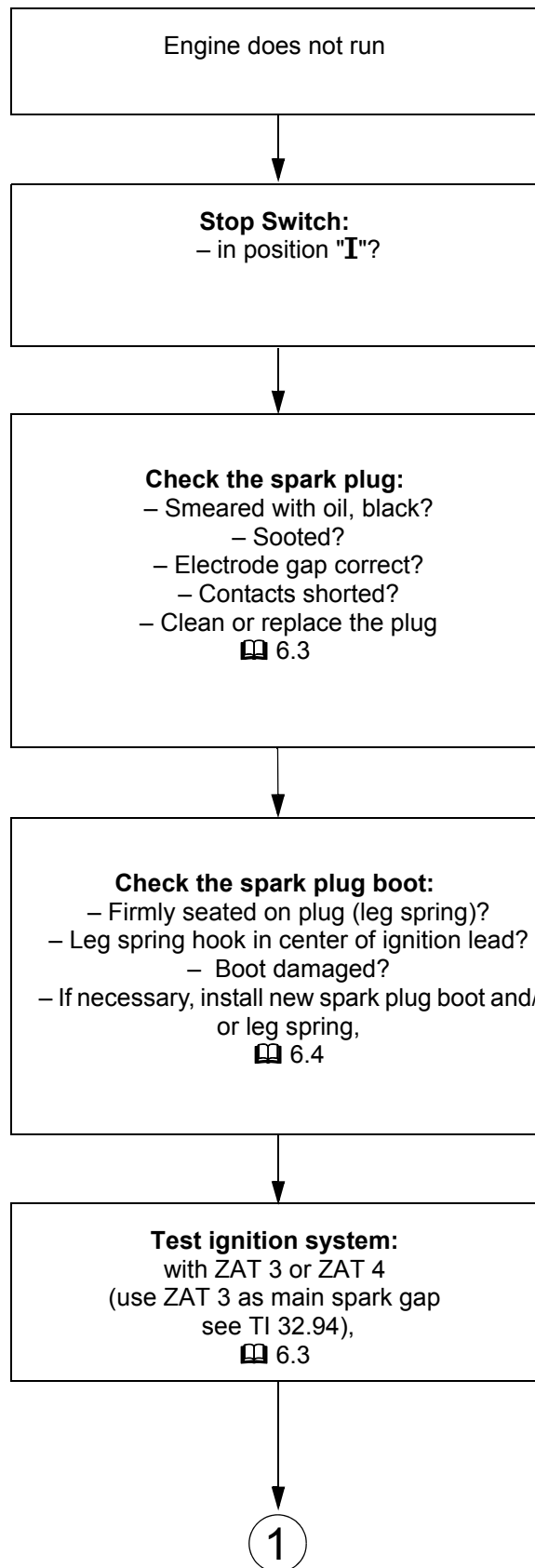

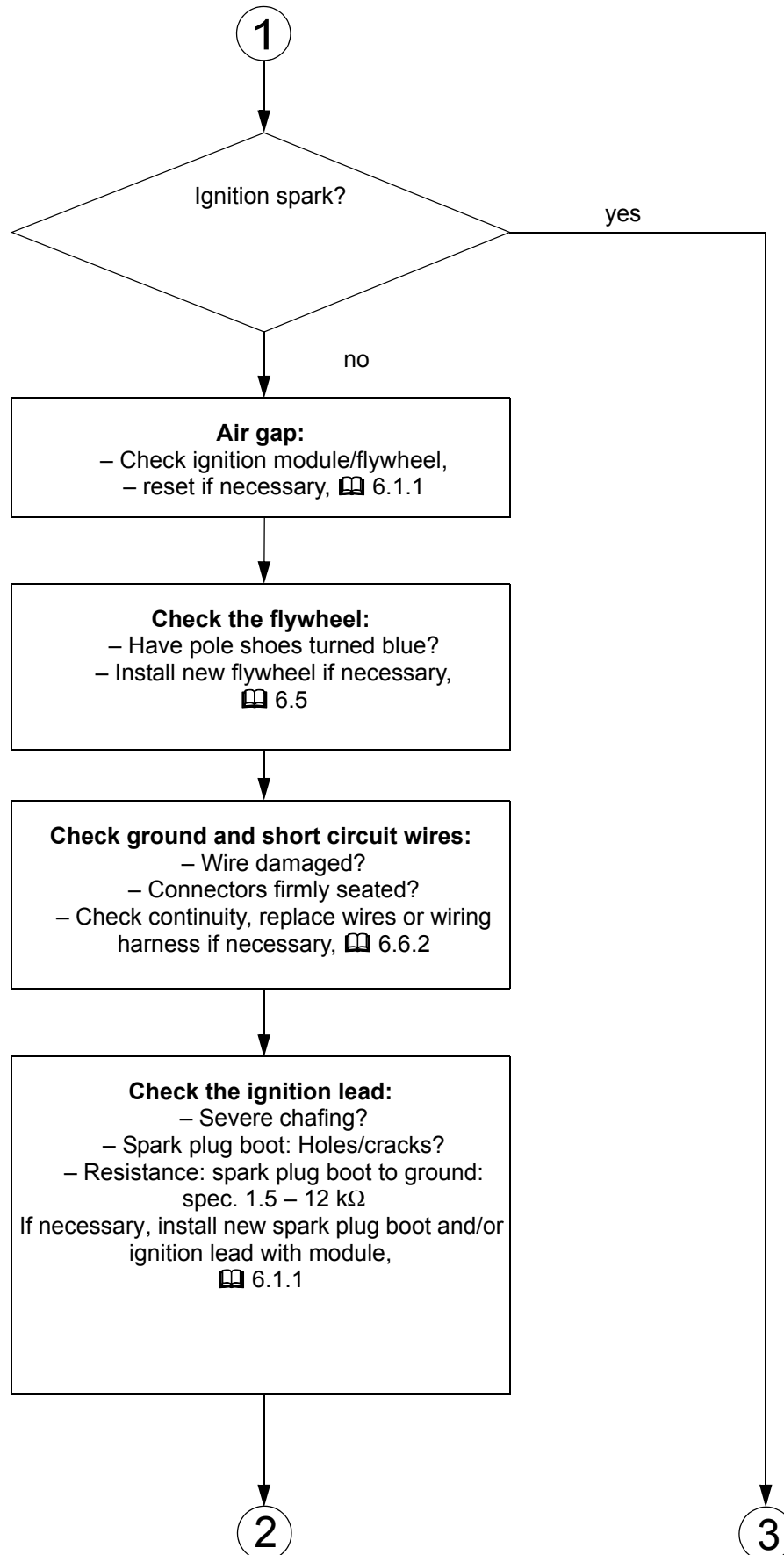

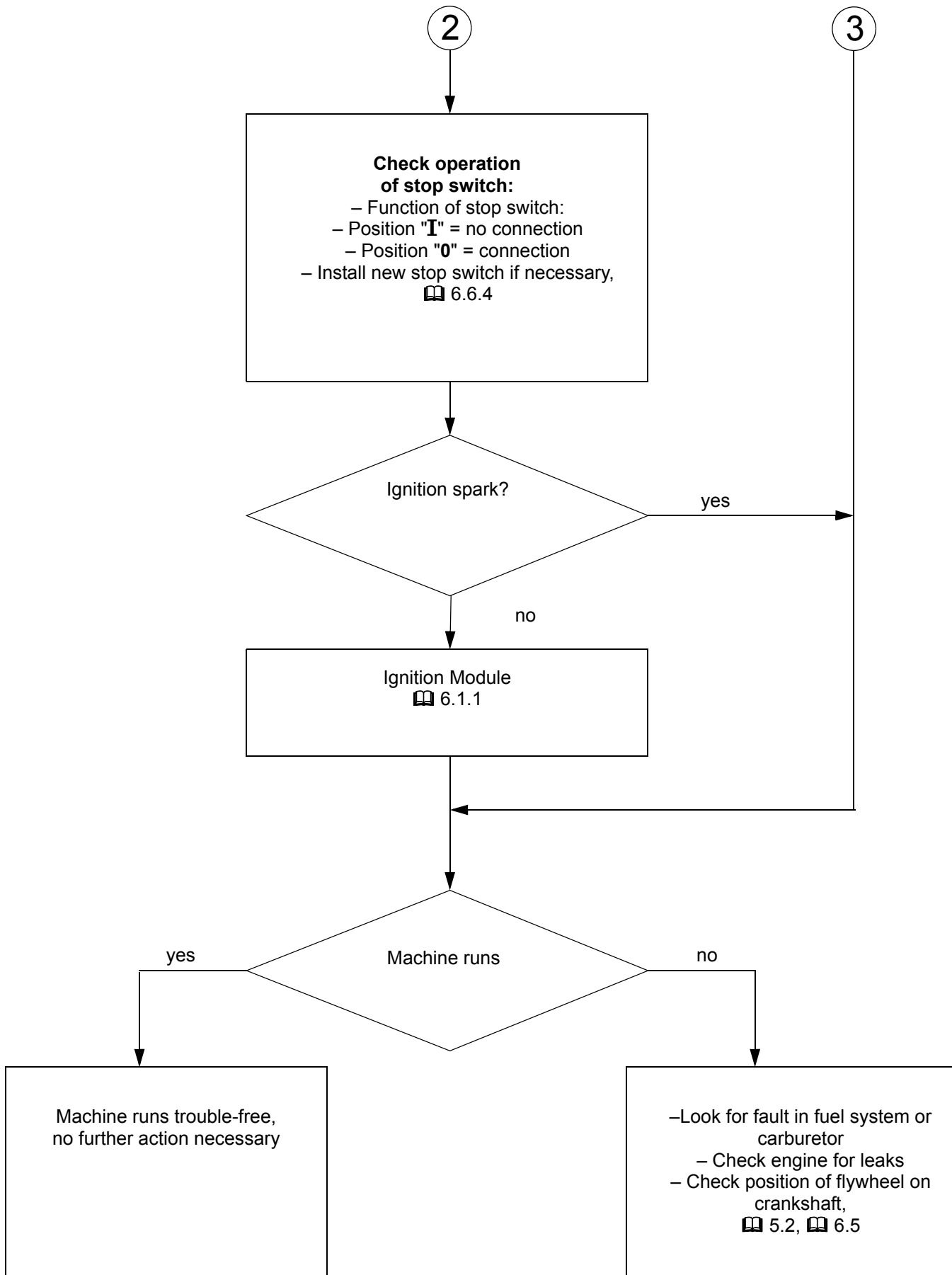

7. Rewind Starter

7.1 General

If the action of the starter rope becomes very stiff and the rope rewinds very slowly or not completely, it can be assumed that the starter mechanism is in order but plugged with dirt. At very low outside temperatures the lubricating oil on the rewind spring may thicken and cause the spring windings to stick together. This has a detrimental effect on the function of the starter mechanism.

In such a case it is sufficient to apply a few drops of a standard solvent-based degreasant (containing no chlorinated or halogenated hydrocarbons) to the rewind spring.

Carefully pull out the starter rope several times and allow it to rewind until its normal smooth action is restored.

Before installing, lubricate the rewind spring and starter post with STIHL special lubricant.

If clogged with dirt or pitch, the entire starter mechanism, including the rewind spring, must be removed and disassembled. Take particular care when removing the spring.

- Clean all components,  13

Models with ErgoStart

- Relieve tension of rewind spring,  7.4

7.2 Removing and Installing

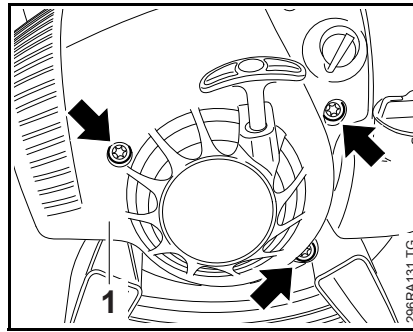

- Take out the screws (arrows).
- Remove the fan housing (1).

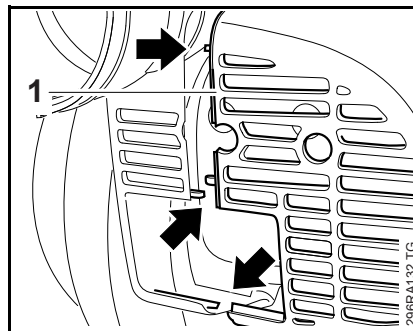

- Position the fan housing (1) so that the guide lugs (arrows) engage the blower housing.

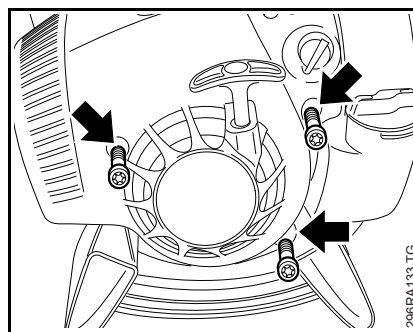

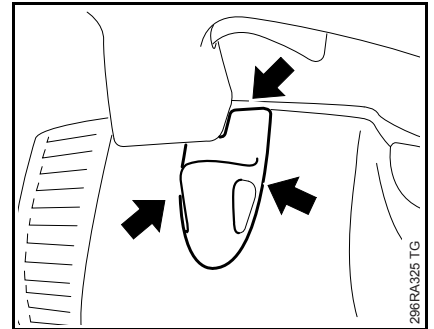

- Insert the screws (arrows) and check the position of the fan housing.
- Tightening torques,  3.4

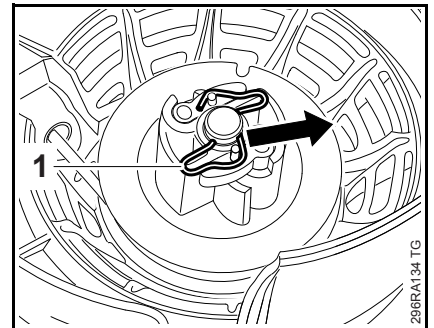

The rubber lip of the spark plug boot must completely seal the opening (arrows) in the fan housing.

7.3 Pawl



- Remove the fan housing,  7.2
- Carefully ease the spring clip (1) off the starter post – the rewind spring may pop out and uncoil.

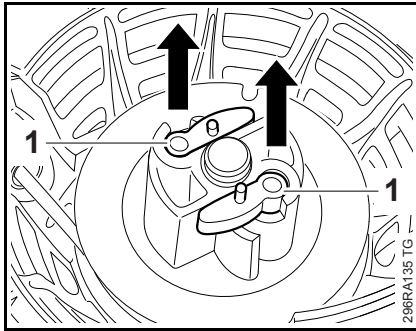

- Pull out the pawls (1), check them and clean or replace if necessary.
- Lubricate the seats of the new pawls, 13

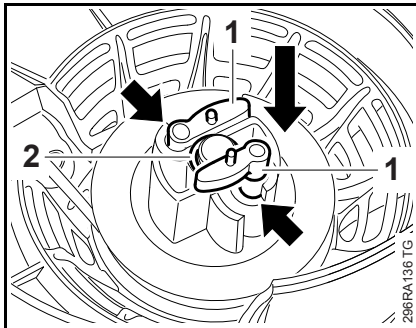

- Fit the new pawls (1) in the bores (arrows) and lubricate the pegs on the pawls with grease, 13

Make sure the washer (2) is in place.

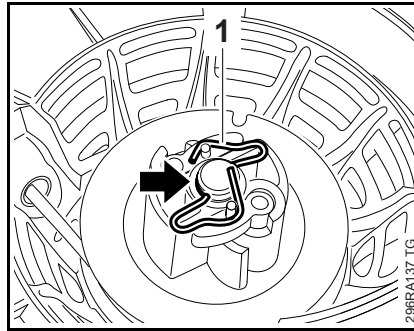

- Position the spring clip (1) so that its loops engage the pegs on the pawls. The rounded part of the spring clip (arrow) must engage the starter post's groove.
- Push the straight part of the spring clip over the starter post until it snaps into the groove.

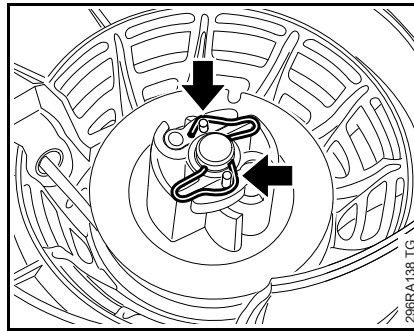

The spring clip's guide loop must be in line with the pawl (arrow).

- Reassemble all other parts in the reverse sequence.

Models with ErgoStart

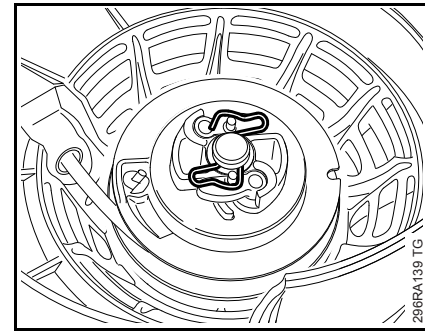

The pawls are seated in the ErgoStart carrier. Removal and installation procedures are the same as for models without ErgoStart.

7.4 ErgoStart

The spring may still be under tension and must always be relieved before assembling.

- Pull out the starter rope until the engine turns – this relieves spring tension.
- Remove the fan housing, 7.2

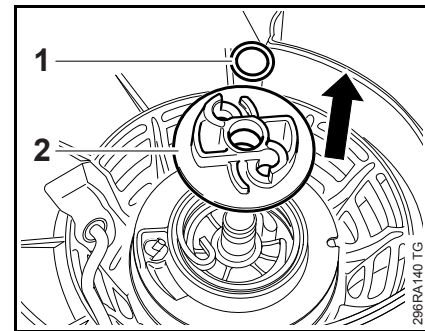

- Remove the spring clip and pawls, 7.3

- Remove the washer (1).
- Pull off the carrier (2).

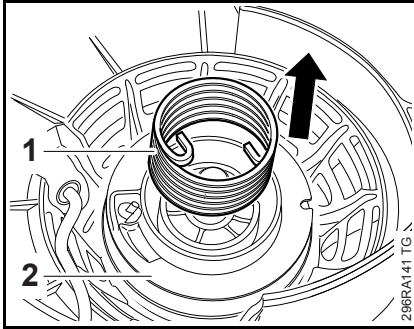

- Pull the spring (1) out of the rope rotor (2) and lift it away.

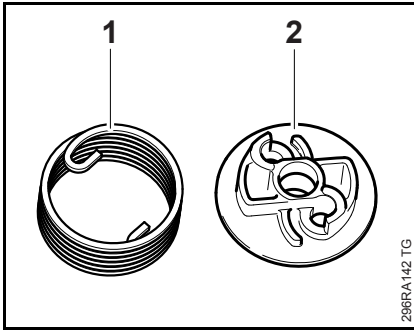

- Inspect the spring (1), carrier (2) and lug on the rope rotor and replace as necessary.

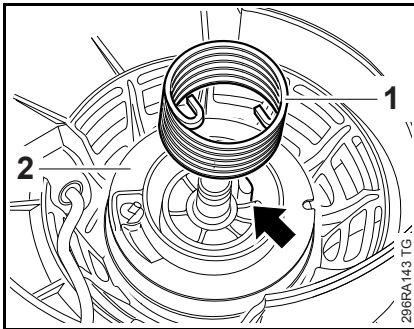

- Push the spring (1) into the rope rotor.
- Position the spring (1) in the rope rotor (2) so that the spring loop engages the lug (arrow).

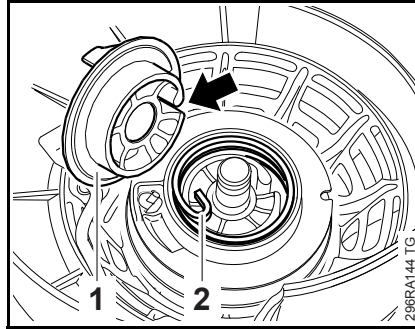

- Position the carrier (1) in the spring so that its lug (arrow) engages the spring loop (2).

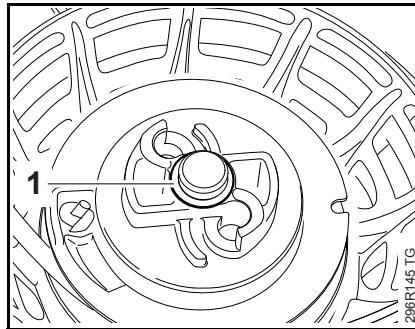

- Fit the washer (1).
- Install the pawls and spring clip, 7.3
- Reassemble all other parts in the reverse sequence.

7.5 Rope Rotor

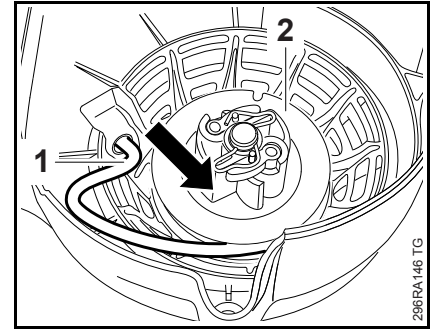

Relieving tension of rewind spring

- Remove the fan housing, 7.2

All models

- Pull out the starter rope (1) about 5 cm and hold the rope rotor (2) steady.
- Take three full turns of the rope off the rope rotor.
- Pull out the rope with the starter grip and slowly release the rope rotor.

The system will not be under tension if the starter rope is broken or the rewind spring is worn.

- Remove the spring clip and pawls, 7.3

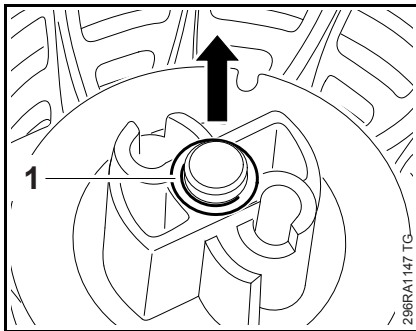

- Remove the washer (1).

Models with ErgoStart

- Remove the ErgoStart, 7.4

Rewind spring must be relaxed.

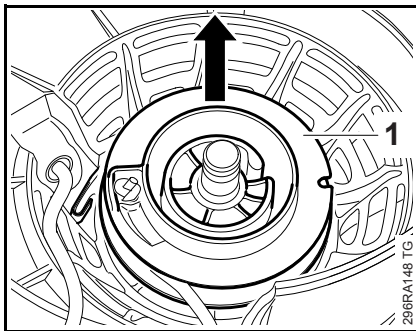

- Carefully remove the rope rotor (1) – the rewind spring may pop out and uncoil.
- Remove the starter rope, 7.6
- Check the rope rotor and replace if necessary.
- Coat starter posts and bore in rope rotor with STIHL special lubricant, 13
- Install the starter rope, 7.6

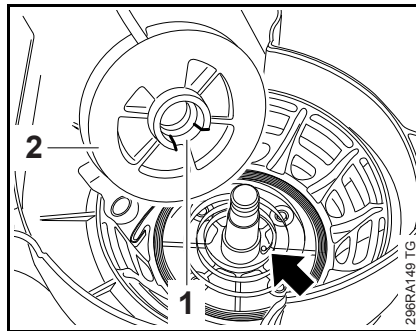

- Fit the rope rotor (2) on the starter post so that the inner spring loop (arrow) engages the recess (1).

The recess in the hub of the rope rotor is the anchor point for the spring.

Models with ErgoStart

- Install the ErgoStart, 7.4

All models

- Fit the cover washer.
- Install the pawls and spring clip, 7.3
- Tension the rewind spring, 7.7
- Lubricate pegs on pawls with grease, 13
- Reassemble all other parts in the reverse sequence.

7.6 Starter Rope / Grip

- Remove the fan housing, 7.2
- Relieve tension of rewind spring, 7.5

Models with ErgoStart

- Remove the ErgoStart, 7.4

All models

The system will not be under tension if the starter rope is broken.

- Remove remaining rope from the rope rotor and starter grip.

Do not shorten the starter rope.

- Remove the rope rotor, 7.5

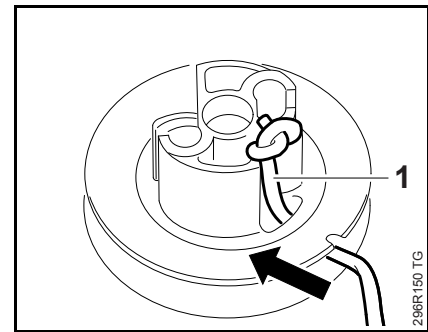

- Push the end of the starter rope (1) out a little and undo the knot.
- Pull the starter rope out of the rotor.

Machines with standard starter grip

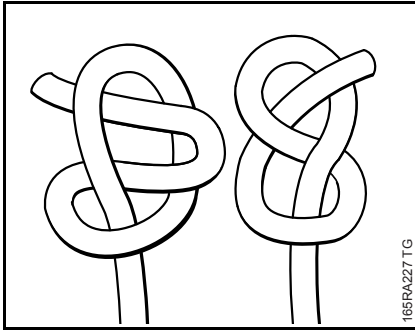

- Pull the old rope out of the starter grip.
- Tie one of the special knots shown in the end of the rope.

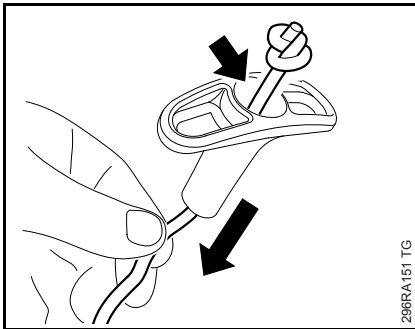

- Thread the rope through the top of the starter grip.
- Pull the rope into the starter grip until the knot is properly seated in the grip (small arrow).

Machines with ElastoStart grip

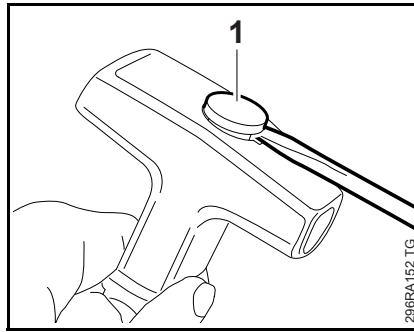

- Use a suitable tool to pry the cap (1) out of the starter grip.

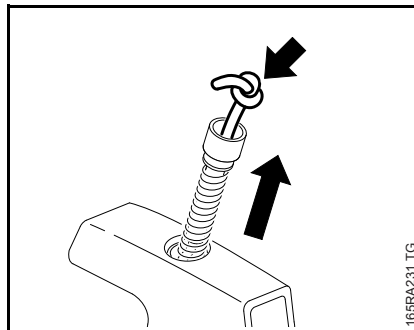

- Pull the sleeve, washers, spring and remaining rope (arrow) out of the grip.
- Pull any remaining rope out of the sleeve. Inspect the individual parts and replace if necessary.

Do not shorten the starter rope.

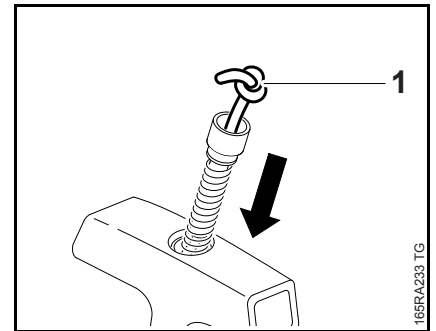

- Thread the new starter rope through the sleeve.
- Tie a simple overhand knot in the end of the new rope.
- Fit the washers and spring.
- Thread the starter rope with sleeve, spring and washers through the starter grip (1).

Make sure the washers and spring remain on the sleeve while the rope its being pulled into the grip.

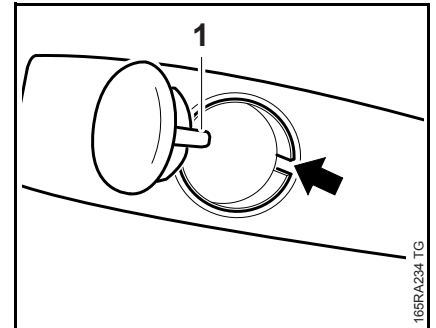

- Position cap so that its lug (1) engages the slot in the starter grip.
- Press the cap into the starter grip.

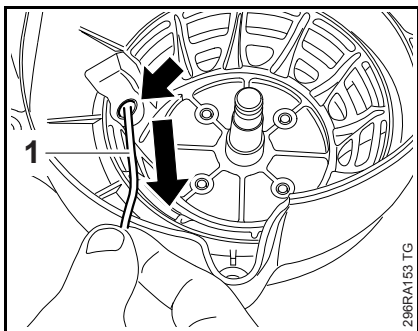

- Thread the starter rope (1) through the guide bushing (arrow).

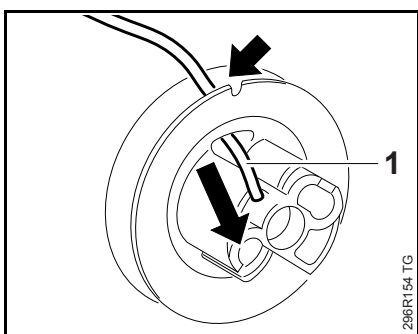

- Thread the rope (1) through the hole in the rotor (arrow).

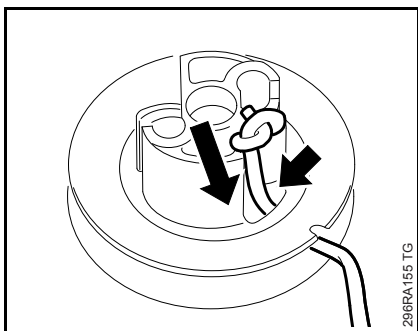

- Tie a simple overhand knot in the end of the new rope.
- Pull rope back until knot locates in recess (arrow) in rope rotor.

Models with ErgoStart

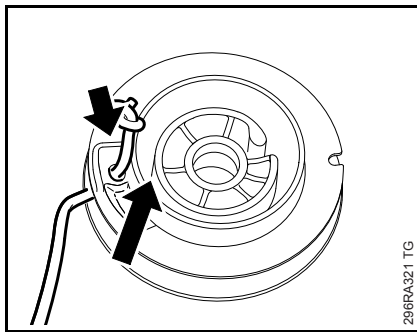

- Thread the rope (1) through the hole in the rotor (arrow).
- Tie a simple overhand knot in the end of the new rope.

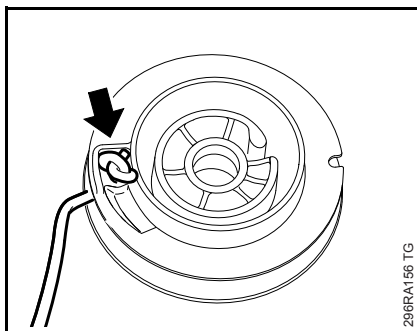

- Pull the rope back until the knot locates in the recess (arrow) in the rope rotor.
- Install the rope rotor and tension the rewind spring, [📖 7.5](#), [📖 7.7](#)
- Install the ErgoStart, [📖 7.4](#)
- Install the fan housing, [📖 7.2](#)

7.7 Tensioning the Rewind Spring

The following procedure is the same for machines with ErgoStart.

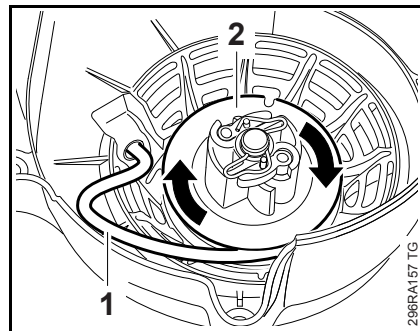

- Remove the fan housing, [📖 7.2](#)
- Pull out a short length of starter rope (1).
- Use the starter rope (1) to rotate the rope rotor (2) six turns clockwise.

The pawls and spring clip must be installed.

Rotating the rope and rope rotor causes the rope to become twisted – the rewind spring is now tensioned.

Hold the rope rotor steady since it will otherwise spin back and may damage the rewind spring.

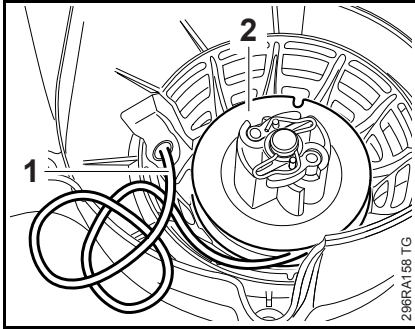

- Hold the rope rotor (2) steady.
- Pull out the twisted rope (1) with the starter grip and straighten it out.

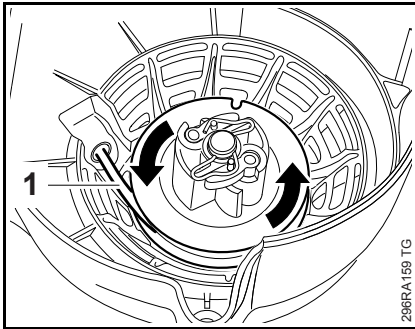

- Hold the starter grip (1) firmly to keep the rope tensioned.
- Let go of the rope rotor and slowly release the starter rope so that it can rewind properly.

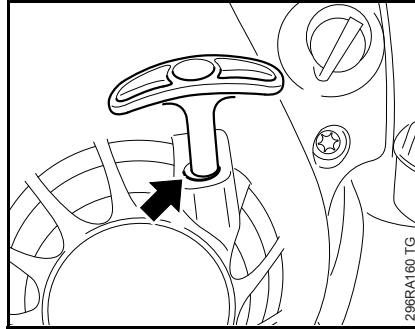

The rewind spring is correctly tensioned when the starter grip sits firmly in the rope guide bushing (arrow) without drooping to one side. If this is not the case, tension the spring by one additional turn.

When the starter rope is fully extended, it must still be possible to rotate the rope rotor at least another half turn before maximum spring tension is reached. If this is not the case, reduce spring tension since there is otherwise a risk of breakage.

To reduce spring tension:
Pull the rope out, hold the rope rotor steady and take off one turn of the rope.

- Install the fan housing, 7.2

7.8 Replacing the Rewind Spring

- Troubleshooting, 4.1

The replacement spring comes ready for installation and is secured in a frame.

Wear a face shield and work gloves.

- Remove the fan housing, 7.2
- Relieve tension of rewind spring if necessary and remove the rope rotor, 7.5
- Remove any remaining pieces of old spring.
- Lubricate the spring with a few drops of STIHL special lubricant before installing, 13

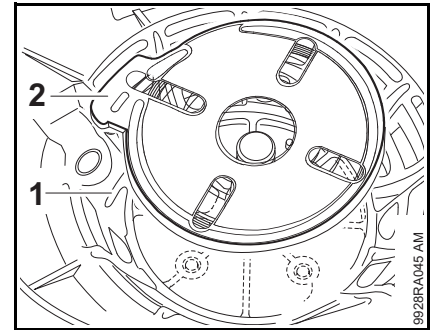

- Line up the replacement spring with frame – the anchor loop (2) must be above the lug (1).

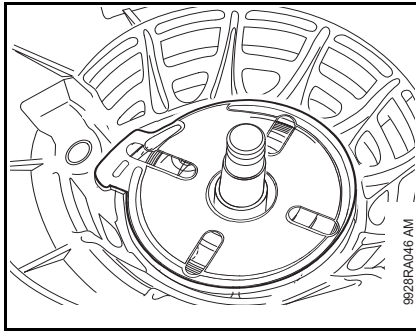

- Fit the rewind spring with frame in position.

Make sure the starter post does not touch the inner spring loop in this process – the spring may pop out and uncoil.

- Push the rewind spring through the frame and into its seat in the fan housing.

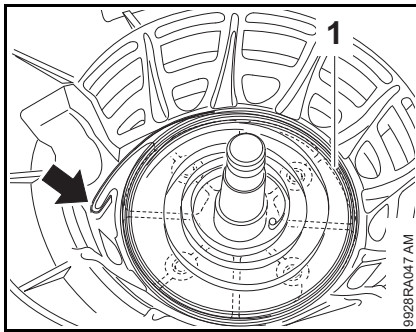

Check that the rewind spring (1) is properly seated and the anchor loop engages the lug (arrow).

If the rewind spring has popped out, refit it in the fan housing as follows:

- Arrange the spring in its original position.

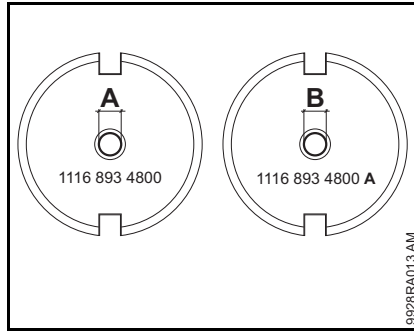

Use installing tool 1116 893 4800 A to fit the rewind spring.

Bore diameter:
A = 10.5 mm
B = 11 mm

An existing installing tool 1116 893 4800 can be modified by enlarging the bore to at least 11 mm.

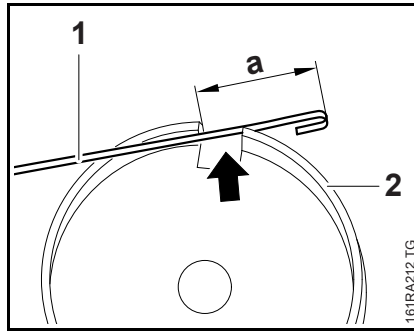

- Place anchor loop (1) in the opening (arrow) in the installing tool (2) 1116 893 4800 – the anchor loop must point inwards.

Make sure the anchor loop does not project too far. It cannot be pushed back after it is fitted in the installing tool – but it can be pulled out.

Check distance of anchor loop from edge of installing tool, $a = 20$ mm.

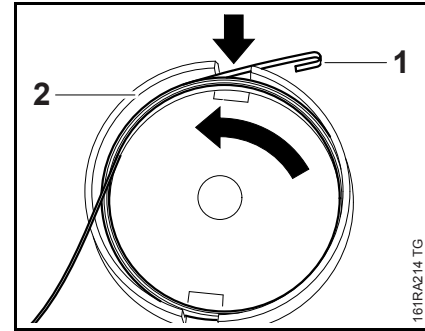

- Fit the rewind spring (1) in the installing tool (2) in the counterclockwise direction, from the outside inwards.

- Hold the spring windings so that they cannot pop out.

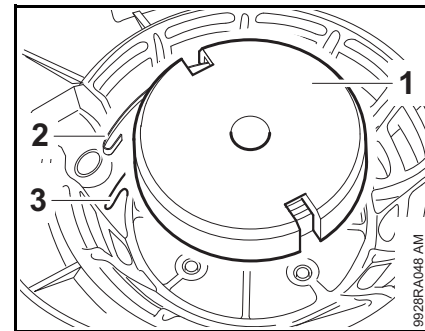

- Push the installing tool (1) with spring on to the starter post.

Position the installing tool (1) so that the spring's anchor loop (2) lines up with the lug (3).

- Use a suitable tool to engage the anchor loop (2) on the lug (3) – pull out the loop a little if necessary.

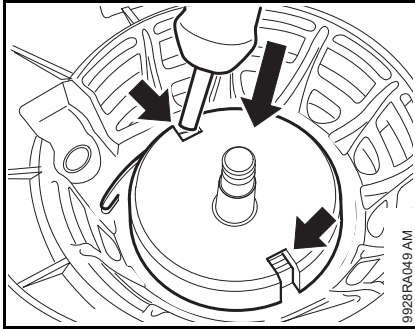

- Apply tool to openings (arrows) to push the spring into its seat in the fan housing.

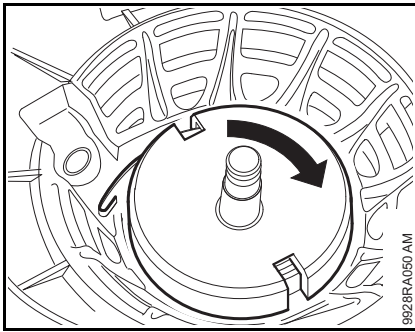

- Press the installing tool against the spring and rotate it slightly clockwise until the spring is properly seated.
- Remove the installing tool.

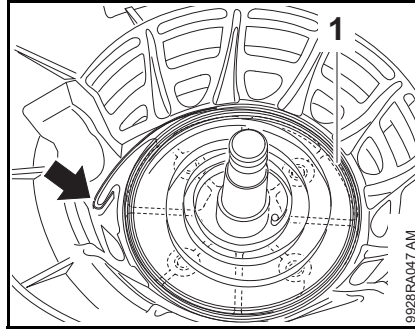

Check that the rewind spring (1) is properly seated and the anchor loop engages the lug (arrow).

- Secure the spring so that it cannot pop out.
- Install the rope rotor, 7.5

Models with ErgoStart

- Install the ErgoStart, 7.4
- Install the pawls, 7.3
- Lubricate pegs on pawls with grease, 13
- Tension the rewind spring, 7.7
- Reassemble all other parts in the reverse sequence.
- Tightening torques, 3.4

7.9 Rope Guide Bushing

Wear on the guide bushing is accelerated by the starter rope being pulled sideways. The wall of the guide bushing wears through and the bushing becomes loose.

- If necessary, remove remaining rope from the rewind starter.
- Remove the rope rotor, 7.5

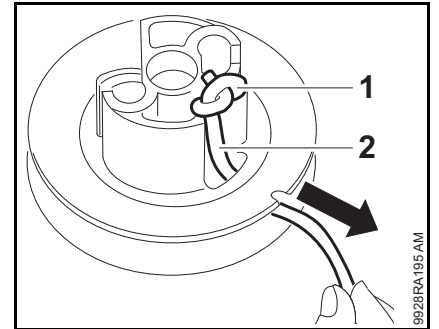

- Pull knot (1) out of recess (2) in rope rotor.
- Undo the knot.
- Pull the starter rope out of the rotor and guide bushing.
- Use a suitable tool to pry the damaged bushing out of the fan housing/starter cover.

Installing the new rope bushing

- Place the bushing in the fan housing/starter cover.

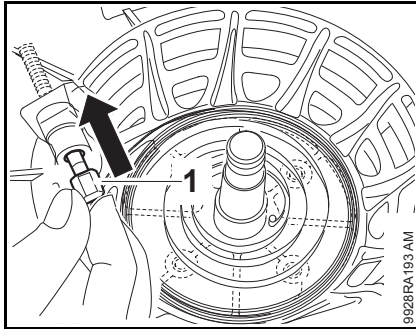

- Insert the screw spindle (1) of installing tool 5910 890 2204 through the guide bushing from inside the housing.

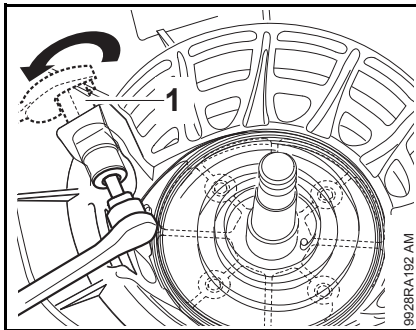



- Fit the thrust sleeve (1) and screw on the hex nut with washer.

- Tighten down the hex nut until the bushing is firmly seated.

The installing tool flares the lower end of the rope bushing.

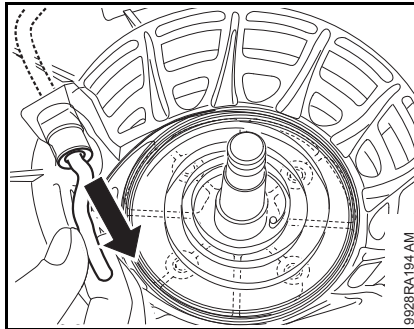
- Remove the installing tool.



- Thread the starter rope through the rope guide bushing from outside and fit in on the rope rotor,  7.6
- Install the rope rotor,  7.5

8. Antivibration System



Repairing SH 86, SH 86 C, BG 66 C, BG 86, BG 86 C

The handle frame and blower housing are connected by vibration-damping springs.

Damaged springs must always be replaced.

8.1 Removing and Installing

The anti-vibration springs are installed between the handle frame and blower housing and must be replaced if faulty.

- Remove the engine,  5.4
- Remove the blower wheel,  11.2

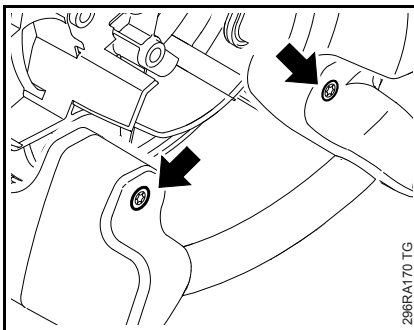

- Take out the screws (arrows).

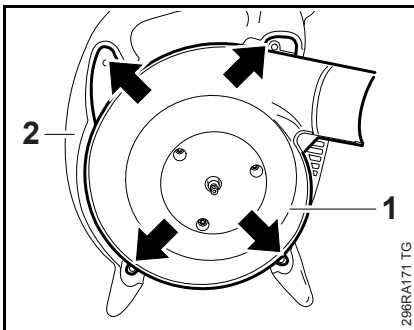

- Pull the blower housing (1) off the handle frame (2) – this releases the anti-vibration springs (arrows) from their seats.
- Lift away the blower housing (1).

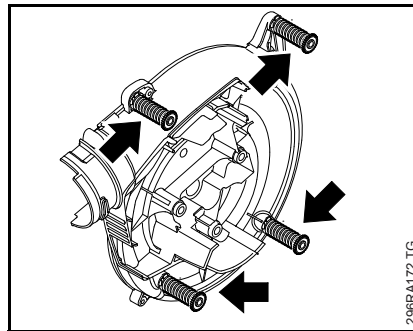

- Unscrew the anti-vibration springs from the bearing plugs (arrows).

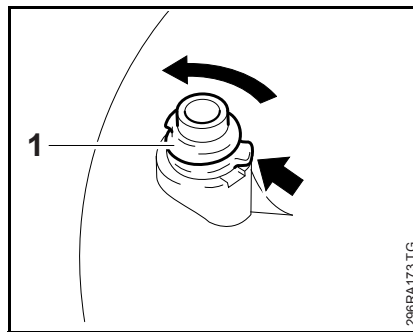

- Apply a suitable tool to the lug (arrow) on the bearing plug (1).

- Carefully tap the bearing plug (1) counterclockwise to loosen it and then unscrew.

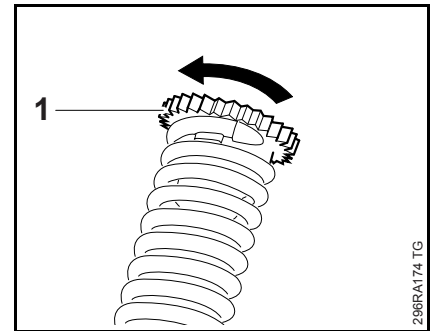

- Unscrew the bearing plugs (1) from the AV springs.

- Check the individual parts and replace if necessary.
- Screw the bearing plugs (1) into the AV springs as far as stop.

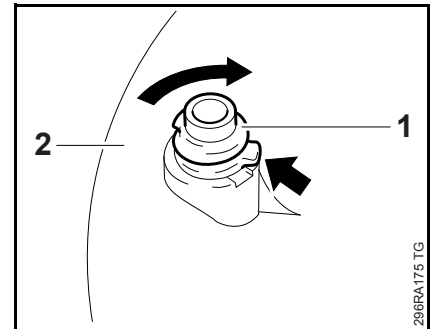

- Screw the bearing plugs (1) clockwise into the bores in the blower housing (2) as far as stop.

- Apply a suitable tool to the lug (arrow) on the bearing plug (1) and rotate it clockwise until it is firmly seated.

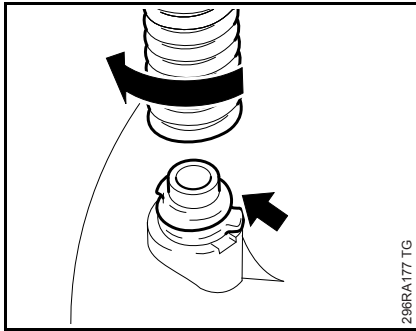

- Screw the preassembled AV springs on to the bearing plugs (arrow) as far as stop.

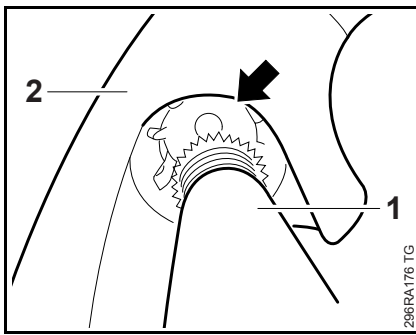

- Position the blower housing (1) so that the anti-vibration springs are in line with their seats (arrow) in the handle frame (2).

Push the blower housing (1) with the anti-vibration springs into the spring seats (arrow) until they snap into position.

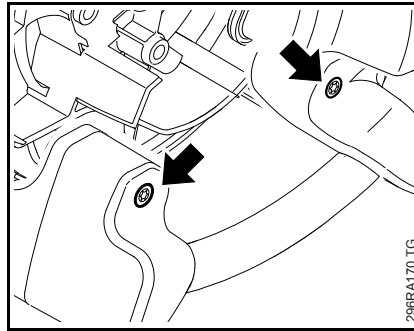

- Fit the screws (arrows).
- Reassemble all other parts in the reverse sequence.
- Tightening torques, 3.4

8.2 Handle on SH 86, SH 86 C, BG 66 C, BG 86, BG 86 C

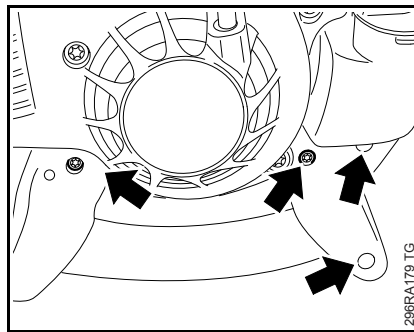

- Take out the screws (arrows).

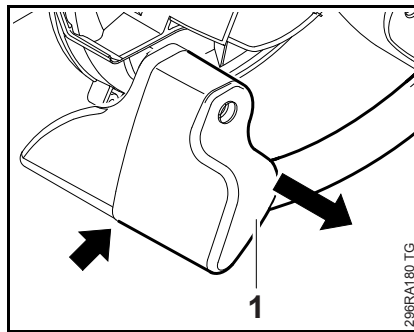

- Lift the handle (1) at the fuel tank side and disconnect it from the cover (arrow).
- Remove the handle (1).

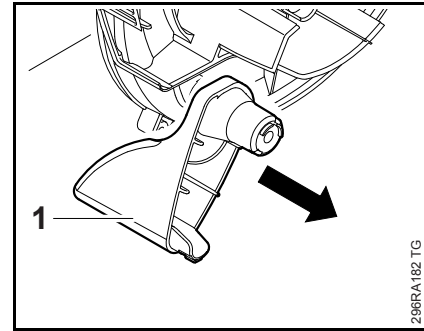

- Pull the cover (1) off the anti-vibration spring.

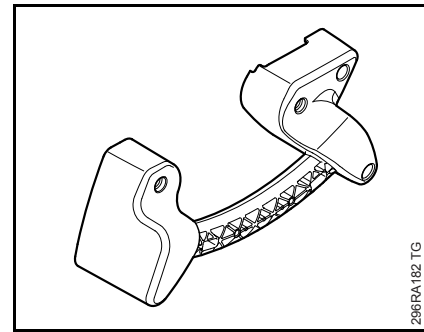

- Check the handle and replace if necessary

If a new handle is fitted, the handle moldings must also be replaced.

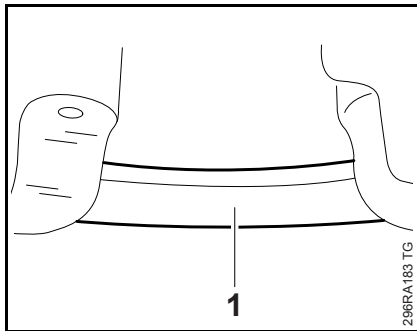

- Inspect the handle moldings.

Only remove the handle moldings if they have to be replaced.

- Use a suitable tool to pry the handle molding (1) off the handle.

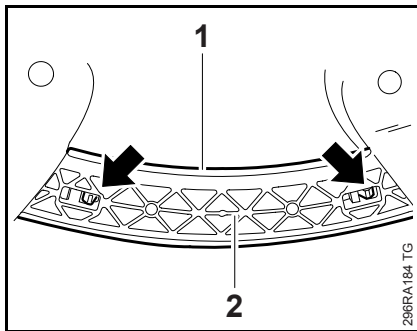

- Push the pegs (arrows) to one side and remove the handle molding (1) from the handle (2).

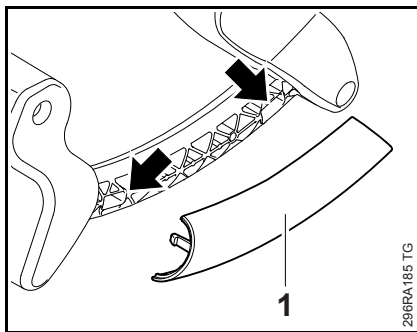

- Push the pegs of the new handle molding (1) into the openings (arrows) until they snap into position.

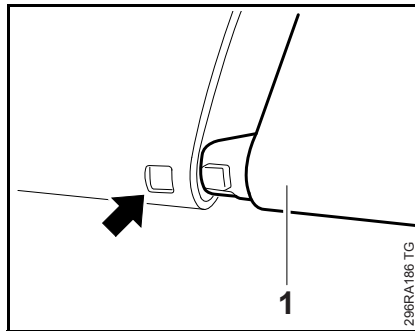

- Preassemble the handle.

- Engage retaining lug of cover (1) in the opening (arrow).

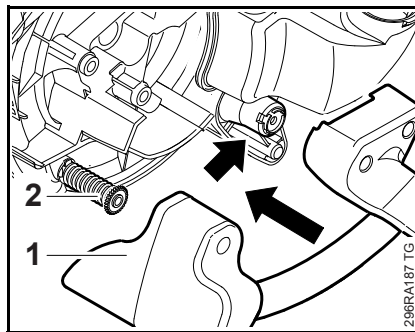

- Push the preassembled handle (1) onto the boss (arrow) and anti-vibration spring (2).

- Press the left side of the handle firmly onto the anti-vibration spring until it snaps into position.

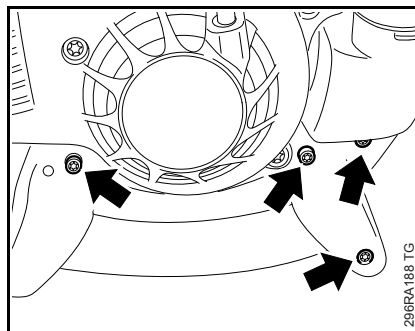

- Insert the screws (arrows) and tighten them down firmly.

- Tightening torques, 3.4

9. Control Levers

9.1 Switch Positions

On these machines the operating modes are set on the handle and the carburetor.

On Handle of Models SH 86, SH 86 C, BG 66 C, BG 86, BG 86 C

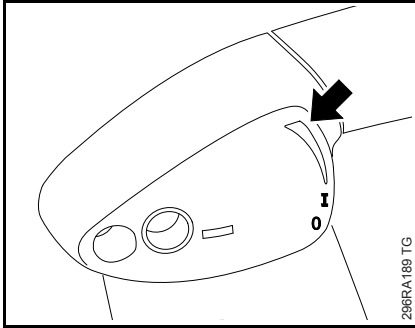

- Position **I** = normal run position – engine runs or can fire in this position
- Position **0** = engine off – ignition is switched off (not locked)
- Setting lever to position shown (arrow) = full throttle position – engine runs at full throttle

On Handle of Models SH 56, SH 56 C, BG 56, BG 56 C, BG 66

The operating modes are selected with the stop switch.

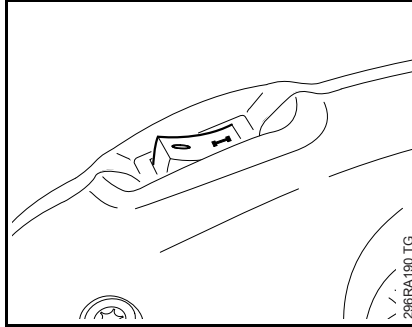

- Position **I** = normal run position – engine runs or can fire in this position
- Position **0** = engine off – ignition is switched off (not locked)

On carburetor of all models

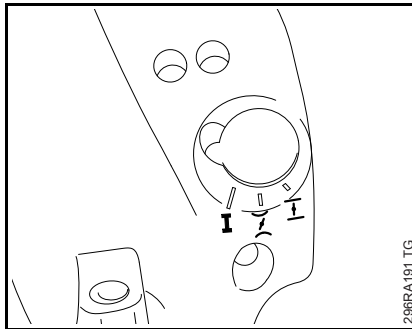



The choke knob returns to the run position when the throttle trigger is operated.

- Position **I** = normal run position
- Position **|→|** = warm start – warm engine is started in this position
- Position **←|** = cold start – cold engine is started in this position

9.2 Setting Lever on SH 86, SH 86 C, BG 66 C, BG 86, BG 86 C

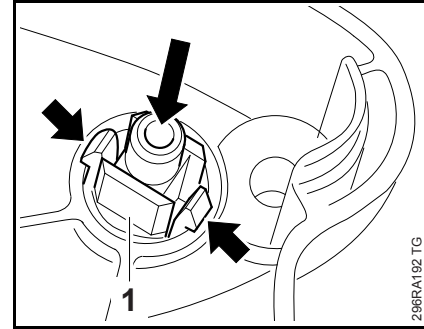
There is no setting lever on models SH 56, SH 56 C, BG 56, BG 56 C, BG 66 since they are controlled by means of the stop switch.



- Remove the handle molding,  9.4
- Squeeze the lugs (arrows) together and push out the setting lever (1).
- Inspect the setting lever and handle molding and replace if necessary

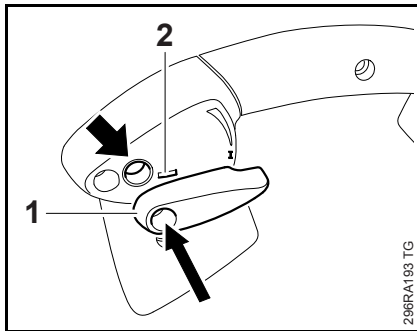

- Line up the setting lever (1) so that it engages the stop (2).
- Push the setting lever (1) into the hole (arrow) until it snaps into position.
- Fit the handle molding, [9.4](#)
- Check operation

9.3 Throttle Trigger on Models SH 56, SH 56 C, BG 56, BG 56 C, BG 66

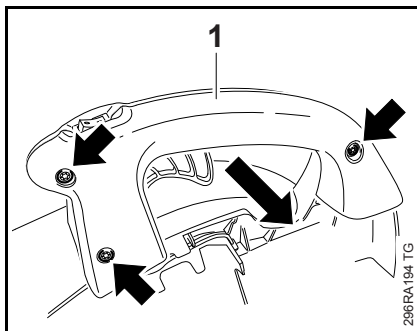

- Remove the fan housing, [7.2](#)
- Pull the boot off the spark plug.
- Take out the screws (arrows).
- Remove the handle molding (1).

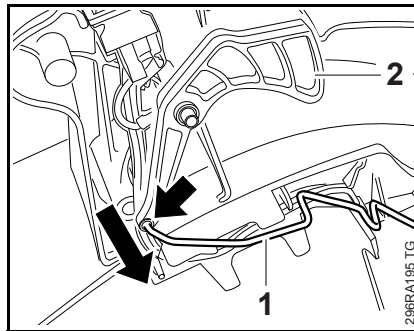

- Disconnect the throttle rod (1) from the trigger (arrow).
- Pull off the throttle trigger (2), check it and replace if necessary.

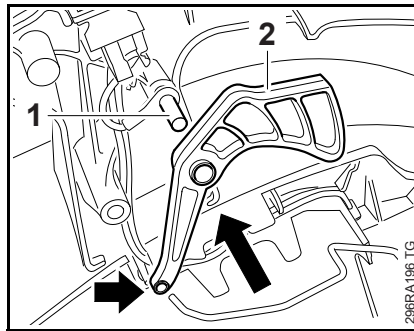

- Check seat of pivot pin (1). If it is damaged, install a new blower housing, [11.3](#)
- Line up the throttle trigger (2) – the arm (arrow) must point in the direction of the throttle rod.

- Push the throttle trigger (2) on to the pivot pin (1).

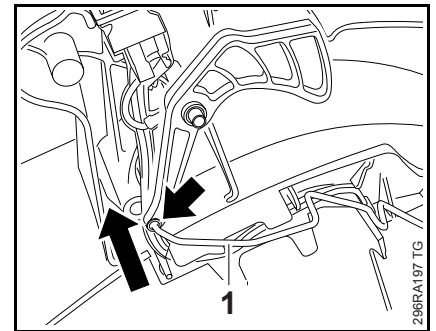

- Attach the throttle rod (1) to the trigger (arrow).

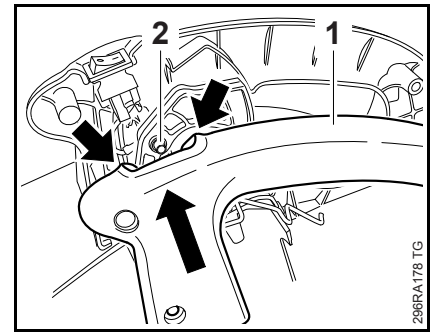

- Position the handle molding (1) and push it on to the pivot pin (2), making sure the recess (arrows) engages the stop switch.

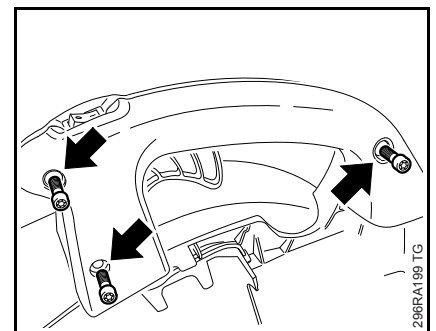

- Fit the screws (arrows).
- Check that handle molding is properly seated.
- Insert the screws and tighten them down firmly.
- Tightening torques, [3.4](#)
- Check operation
- Reassemble all other parts in the reverse sequence.

9.4 Throttle Trigger on Models SH 86, SH 86 C, BG 66 C, BG 86, BG 86 C

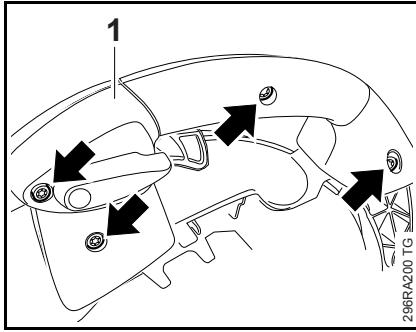

- Remove the fan housing, 7.2
- Pull the boot off the spark plug.
- Take out the screws (arrows).
- Carefully remove the handle molding (1) – the cam may fall out.

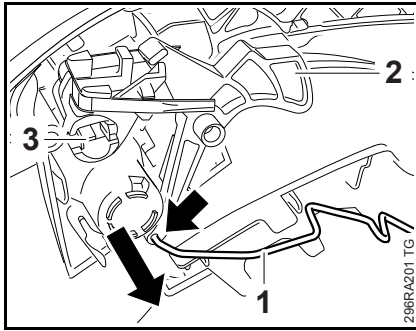

- Disconnect the throttle rod (1) from the trigger (arrow).
- Pull off the throttle trigger (2) and cam (3).
- Check the individual parts and replace if necessary.

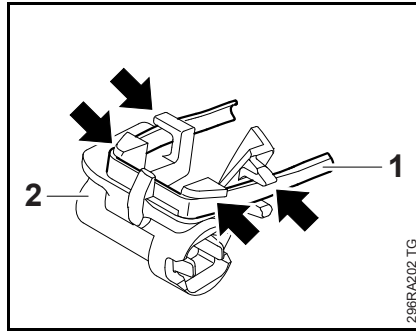

- Ease the detent spring (1) apart and lift it out over the guides (arrows) – do not overstretch the detent spring.
- Check the cam (2) and detent spring (1) and replace if necessary

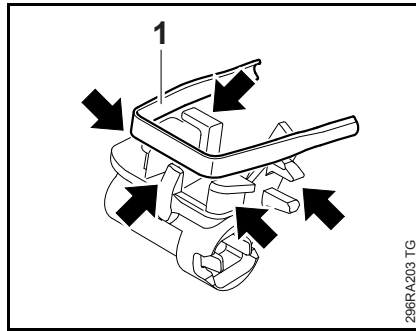

- Push the detent spring (1) into the guides (arrow) until it snaps into position – do not overstretch the detent spring.

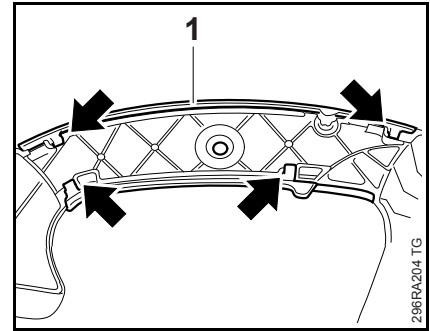

- Ease the lugs (arrows) apart and push the inner handle molding (1) off the handle frame.

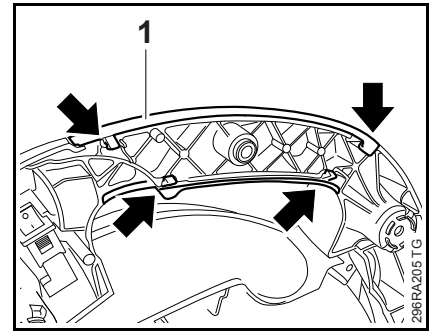

- Ease the lugs (arrows) apart and push the outer handle molding (1) off the handle frame.

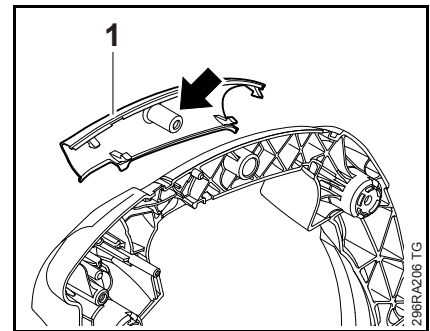

- Position the handle molding (1) with the peg (arrow) against the handle frame.

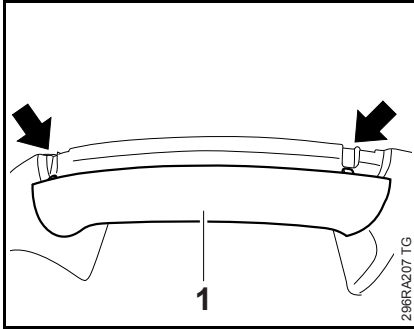

- Push lugs of handle moldings into the recesses (arrows) until they snap into position.

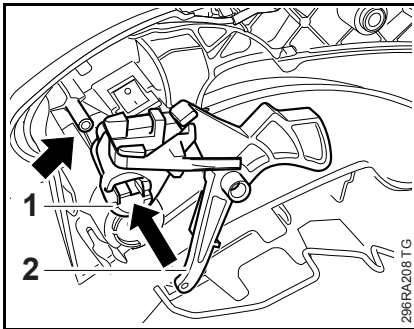

- Position the cam so that the square seat (1) faces away from the handle frame.
- Position the throttle trigger so that the arm (2) faces in the direction of the throttle rod.
- Push the cam and throttle trigger onto the pivot pins (arrows).

If a pivot pin is broken, install a new handle housing.

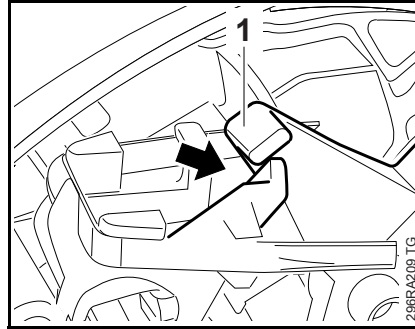

The lug (1) must engage the cam's guide (arrow).

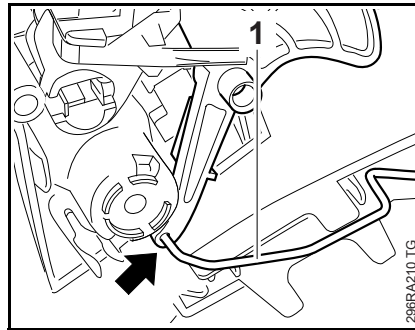

- Carefully attach the throttle rod (1) to the trigger (arrow).

The cam may fall out.

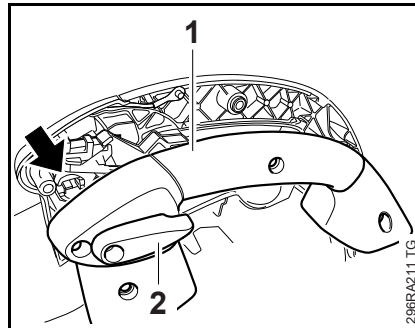

- Position the handle molding (1) so that the setting lever (2) pivot engages the cam seat (arrow).

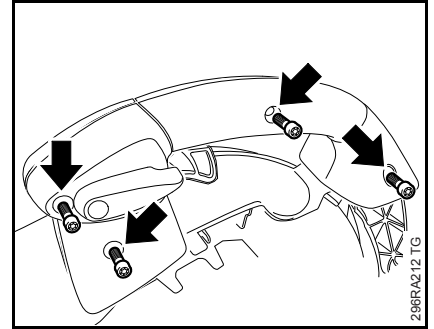

- Fit the screws (arrows).
- Check that handle molding is properly seated.
- Insert the screws and tighten them down firmly.
- Check operation
- Reassemble all other parts in the reverse sequence.
- Tightening torques, [3.4](#)

10. Fuel System

When working on fuel system hoses:

To avoid damaging hoses, do not use pliers or other sharp-edged tools.

Disconnect and connect hoses by hand, i.e. without tools.

Use STIHL press fluid when fitting hoses,  13

10.1 Air Filter

Dirty air filters reduce engine power, increase fuel consumption and emissions, and make starting more difficult.

The air filter should be checked when there is a noticeable loss of engine power.

– See also Troubleshooting,  4.4

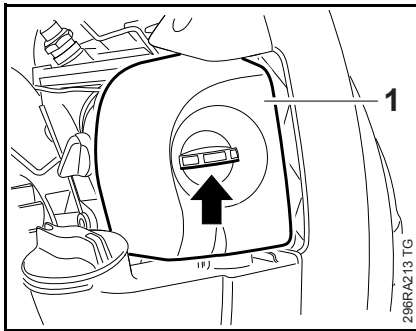

● Open the twist lock (arrow).

– Remove the filter cover (1).

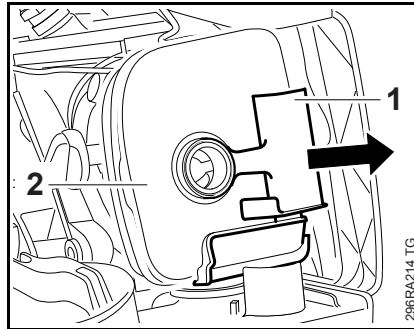

● Pull off the insert (1).

– Take the filter (2) out of the housing and check it – see instruction manual.

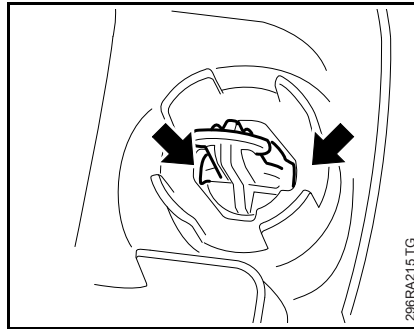

● Squeeze the tabs (arrows) together and push the twist lock out of the filter cover.

– Check the individual parts and replace if necessary.

– Reassemble in the reverse sequence.

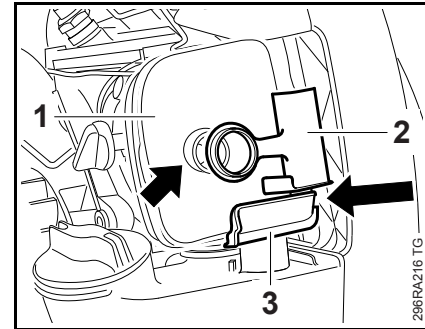

– Fit the filter (1) in the filter housing.

– Line up the insert (2) – the arm (3) must face downwards.

● Push the insert (2) into its seat (arrow).

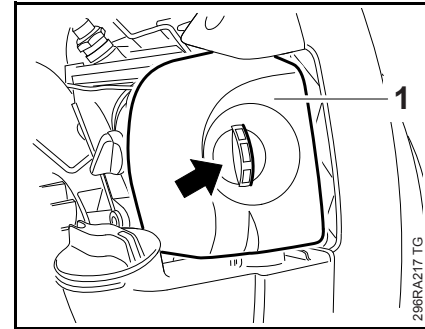

– Fit the filter cover (1).

● Close the twist lock (arrow).

10.2 Baffle / Filter Housing

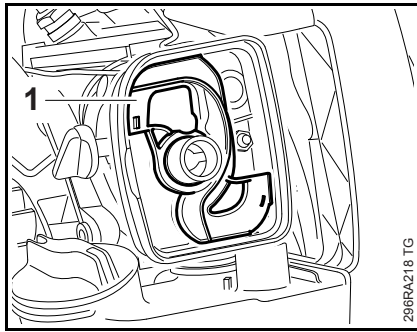

- Remove the fan housing, 7.2
- Remove the air filter, 10.1
- Pull out the baffle (1), check it and replace if necessary.

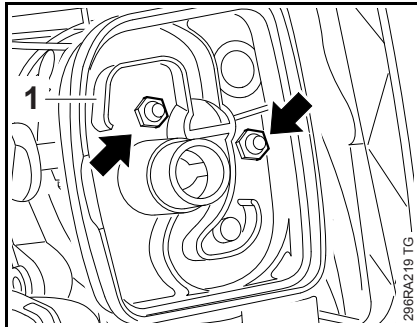

- Use screwdriver 5910 890 2420 to unscrew the nuts (arrows).
- Remove the filter housing (1).
- Inspect the filter housing and baffle and replace if necessary.

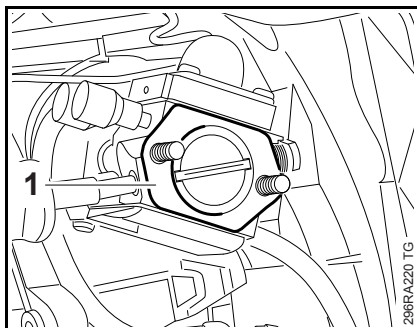

- Remove the gasket (1).

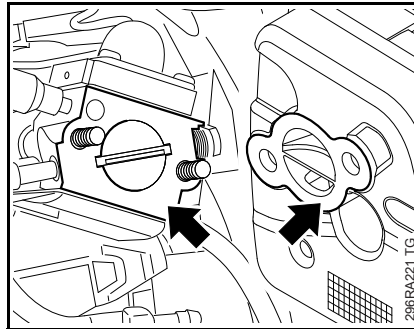

- Check and clean the sealing faces (arrows) on the carburetor and filter housing, 13

Always replace components with damaged sealing faces.

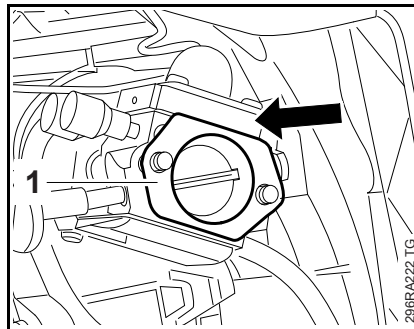

- Fit the gasket (1).

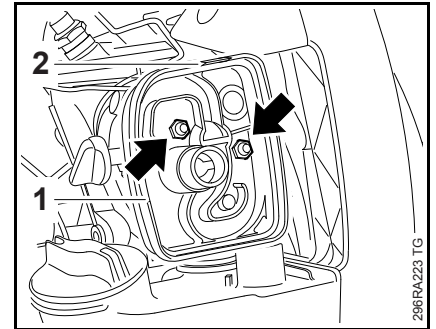

- Position the filter housing (1) so that the tab (2) is at the top.
- Slide the filter housing (1) over the studs.
- Fit the nuts (arrows) and tighten them down firmly.

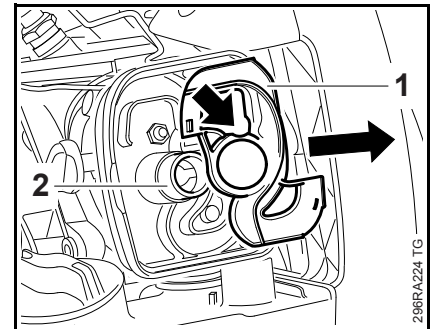

- Position the baffle (1) so that the recess (arrow) is at the top.
- Push the baffle (1) onto its seat (2).
- Reassemble all other parts in the reverse sequence.
- Tightening torques, 3.4

10.3 Removing and Installing the Carburetor

- Remove the fan housing, 7.2
- Remove the filter housing, 10.2
- Open the fuel tank cap and drain the fuel tank, 1

Disconnect the fuel hoses only when the tank cap is open.

Always install new fuel hoses.

- Disconnect the throttle rod, 10.6

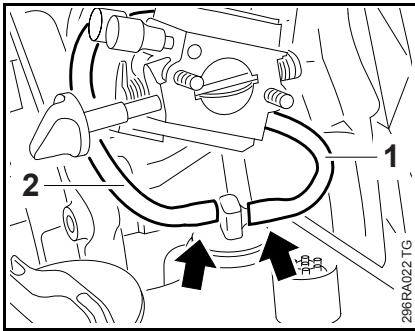

- Disconnect the fuel suction hose (1) and fuel return hose (2) from the stubs (arrows).

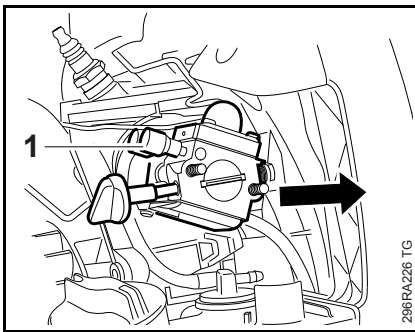

- Remove the carburetor (1).
- Check the carburetor and service or replace if necessary.

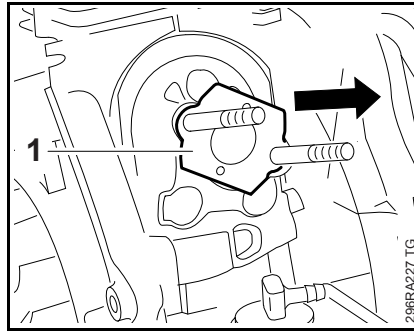

- Remove the gasket (1).

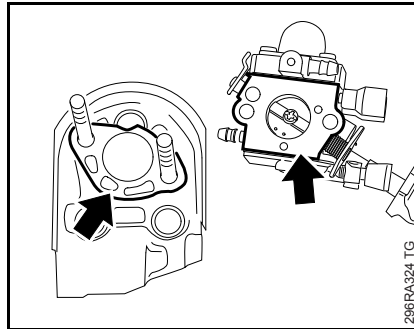

- Check and clean the sealing faces (arrows) on the spacer flange and carburetor, 13

Always replace components with damaged sealing faces.

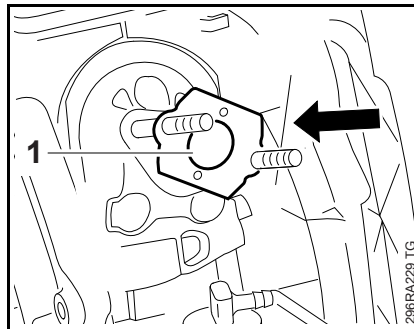

- Fit the gasket (1).

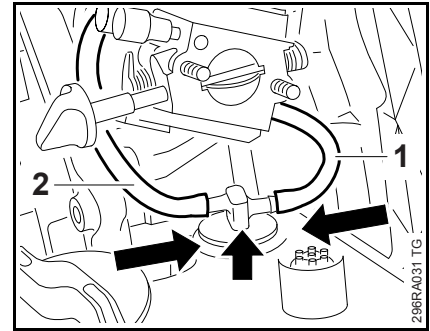

- Push the carburetor into position.

- Push the new fuel suction hose (1) and fuel return hose (2) onto the stubs on the connector (small arrow).

Take care not to damage the new fuel hoses.

- Install the throttle rod, 10.6
- Reassemble all other parts in the reverse sequence.
- Tightening torques, 3.4

10.3.1 Leakage test

In the case of problems with the carburetor or fuel supply system, also check and clean or replace the tank vent,  10.8

The carburetor can be tested for leaks with the pump 0000 850 1300.

Install new fuel hoses after completing the test.

Take care not to damage the new fuel hoses.

- Remove the carburetor,  10.3

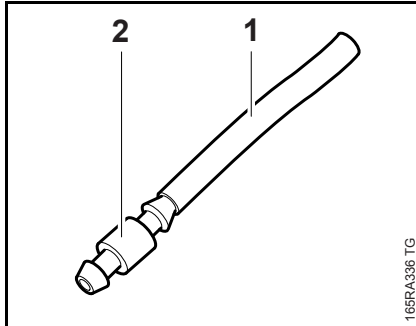

- Push the pressure hose (1) 1110 141 8600 onto the nipple (2) 0000 855 9200.

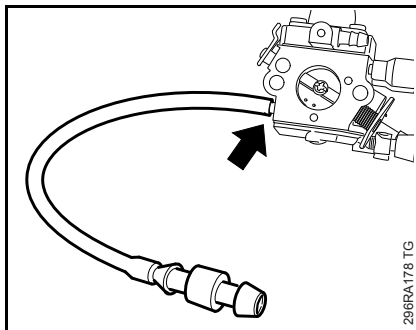



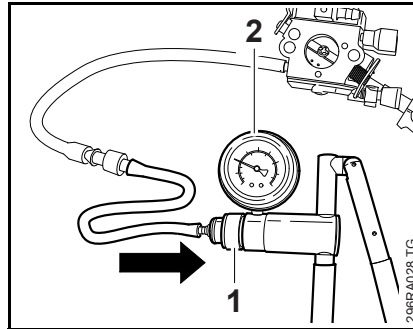

- Push the pressure hose with nipple onto the carburetor's fuel stub (arrow).



- Push the pressure hose of pump 0000 850 1300 onto the nipple.
- Push the ring (1) to the right and pump air into the carburetor until the pressure gauge (2) indicates a pressure of about 0.8 bar (80 kPa).

If this pressure remains constant, the carburetor is airtight. However, if it drops, there are three possible causes:

1. The inlet needle is not sealing (foreign matter in valve seat, sealing cone of inlet needle is damaged or inlet control lever is sticking). Remove to clean,  10.4.2
2. Metering diaphragm or gasket damaged, replace if necessary,  10.4.1
3. Pump diaphragm or gasket damaged, replace if necessary,  10.4.3

- After completing the test, push the ring (1) to the left to vent the system and then pull the fuel hose off the carburetor.
- Install the carburetor,  10.3
- Reassemble all other parts in the reverse sequence.
- Tightening torques,  3.4

10.4 Servicing the Carburetor

10.4.1 Metering Diaphragm / Manual Fuel Pump

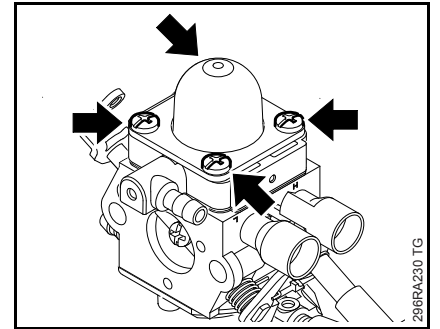

- Remove the carburetor,  10.3
- Take out the screws (arrows).

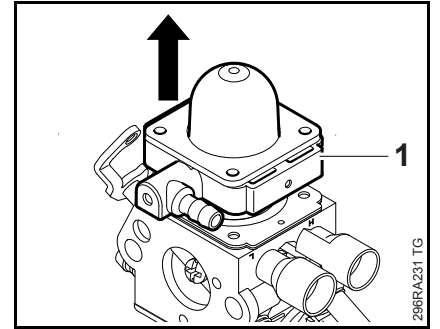

- Remove the complete flange (1).

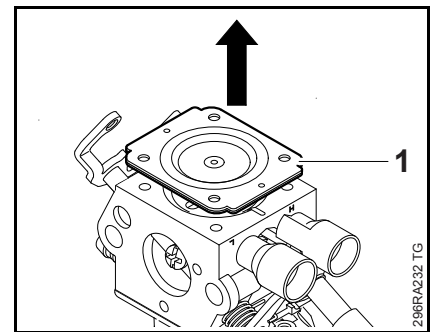

- Remove the metering diaphragm and gasket (1).

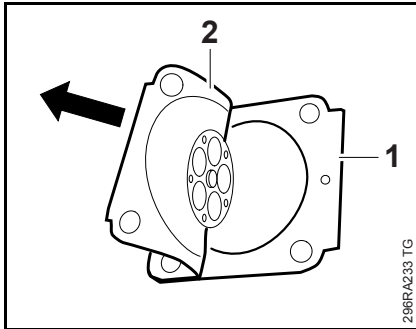

- Carefully separate the metering diaphragm (2) and gasket (1).

The diaphragm material is subjected to continuous alternating stresses and eventually shows signs of fatigue, i.e. the diaphragm distorts and swells and has to be replaced.

- Check the metering diaphragm for signs of damage and wear and replace if necessary.
- Install a new gasket.

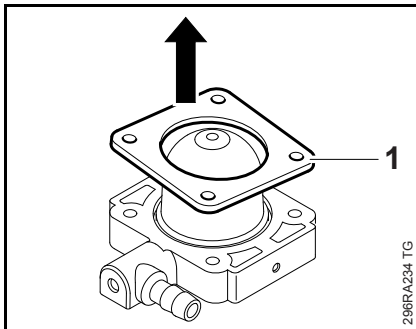

- Remove the flange (1).

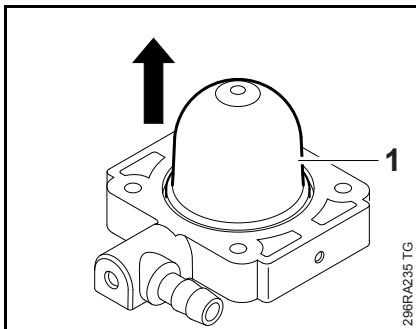

- Remove the cap (1).

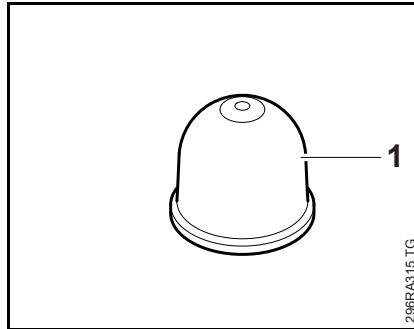

- Check the cap and replace it if necessary.

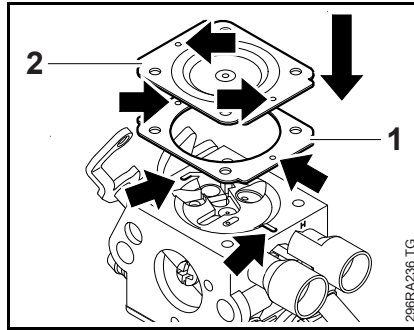

- Line up the gasket (1) and metering diaphragm (2) with the holes (arrows).

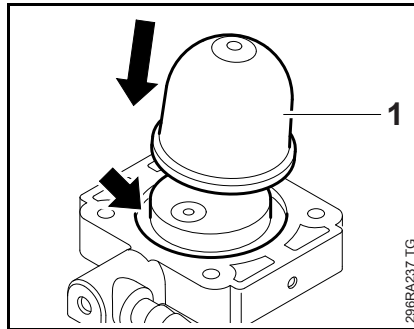

- Position the cap (1) in the annular groove (arrow).
- Fit the end cover.

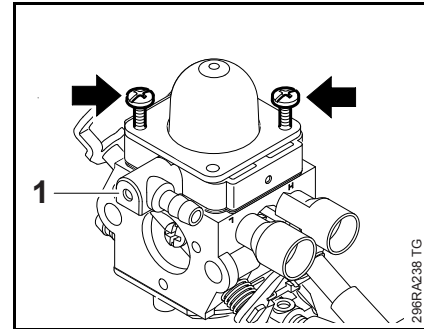

- Place the flange in position – stub (1) must be on same side as the throttle shutter.

- Insert two screws (arrows) to hold the flange, gasket and diaphragm in position.

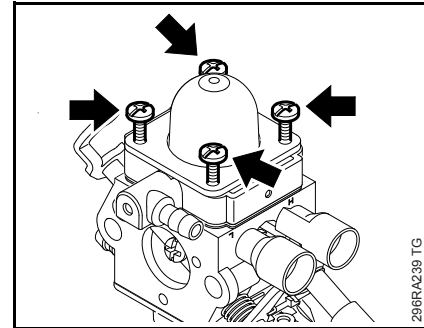

- Insert the other screws.

- Tighten down the screws (arrows) firmly in a crosswise pattern.

- Reassemble all other parts in the reverse sequence.
- Check operation

10.4.2 Inlet Needle

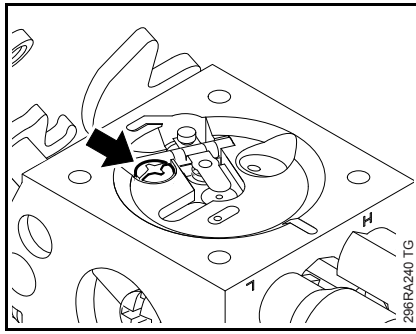

– Remove the metering diaphragm, [10.4.1](#)

- Take out the screw (arrow).

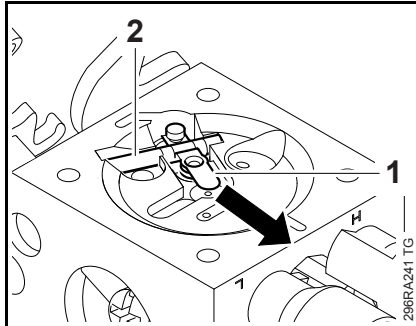

- Pull the inlet control lever (1) with spindle (2) out of the inlet needle's groove.

The small spring under the inlet control lever may pop out.

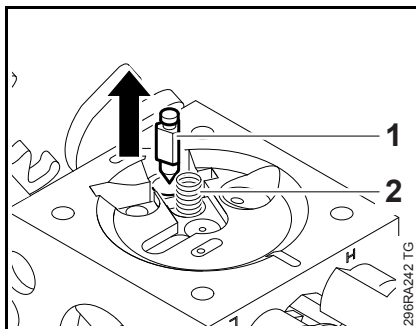

- Remove the inlet needle (1).
- Remove the spring (2). Inspect and replace if necessary.

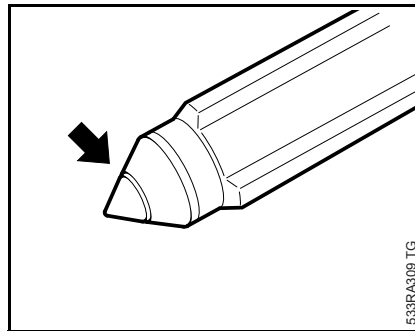

- If there is an annular indentation (arrow) on the sealing cone of the inlet needle, fit a new inlet needle.

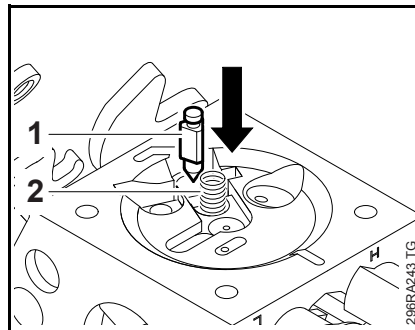

- Fit the inlet needle (1).
- Fit the spring (2) in the bore.

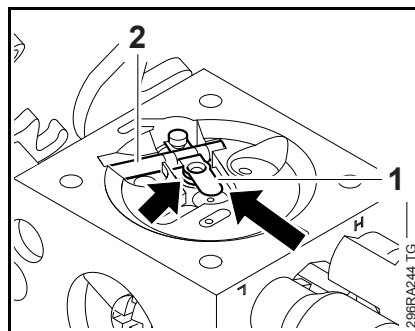

- Position the inlet control lever (1) with spindle (2) on the spring's seat (arrow) first, then slide the inlet control lever's clevis into the groove in the inlet needle.

Make sure the spring locates on the control lever's nipple.

- Press the inlet control lever down and secure it with the screw.
- Check that the inlet control lever moves freely.
- Install the metering diaphragm, [10.4.1](#)
- Reassemble all other parts in the reverse sequence.

10.4.3 Pump Diaphragm

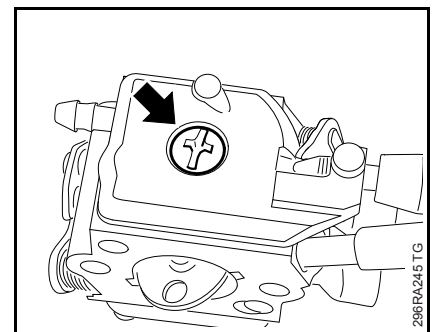

- Remove the carburetor, [10.3](#)
- Take out the screw (arrow).

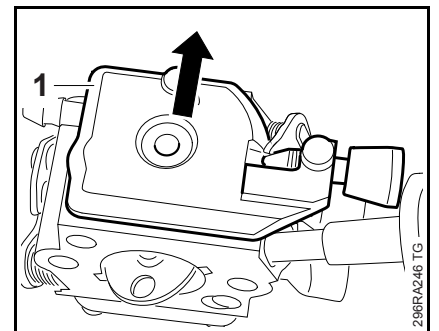

- Carefully remove the end cover (1).

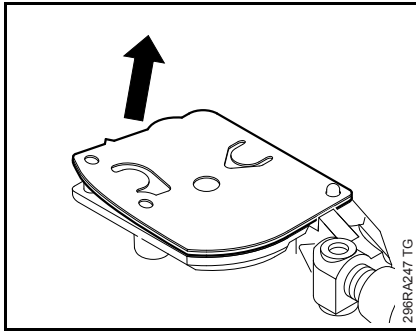

- Carefully remove the gasket with pump diaphragm from the end cover.

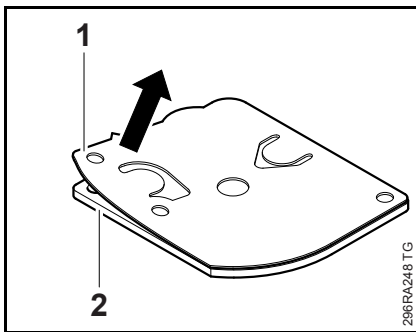

- Carefully separate the pump diaphragm (1) and gasket (2).

The diaphragm material is subjected to continuous alternating stresses and eventually shows signs of fatigue, i.e. the diaphragm distorts and swells and has to be replaced.

- Check the pump diaphragm for signs of damage and wear. Install a new gasket.
- Check fuel strainer for contamination and damage. Clean or replace if necessary.

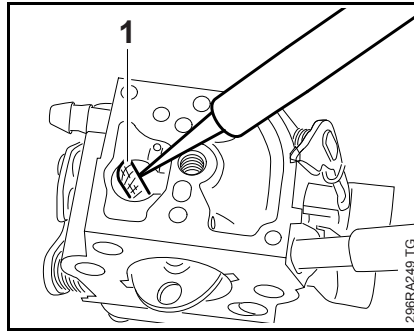

- Use a needle to remove the fuel strainer (1) from the carburetor body. Clean or replace the fuel strainer.
- Reassemble in the reverse sequence.

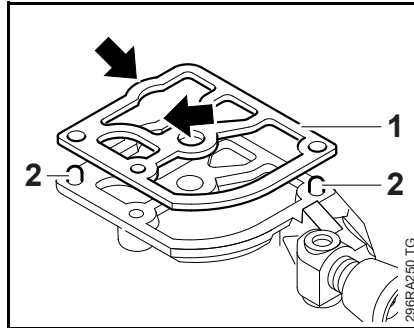

- Fit the gasket (1) so that the contours (arrows) match and it is held in position by the pegs (2).

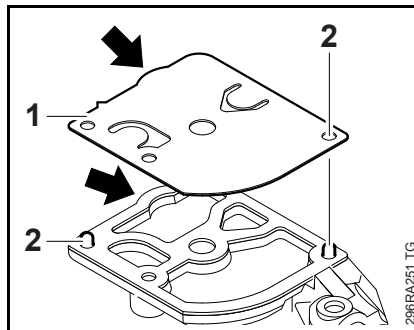

- Fit the diaphragm (1) on the gasket so that the contours (arrows) match and it is held in position by the pegs (2).

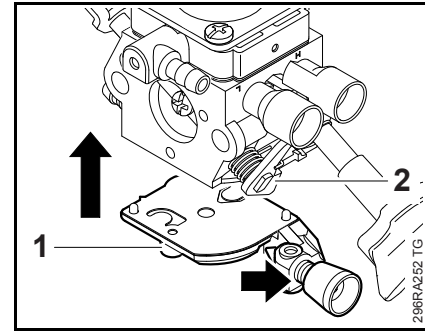

- Position the end cover (1) so that the idle speed screw (arrow) is at the same side as the adjusting screws.
- Turn lever (2) on throttle shaft a little and place the end cover (1) against the carburetor body from below so that the gasket and pump diaphragm remain in position on the end cover.
- Move the end cover (1) a little until its pegs engage the holes in the carburetor body.

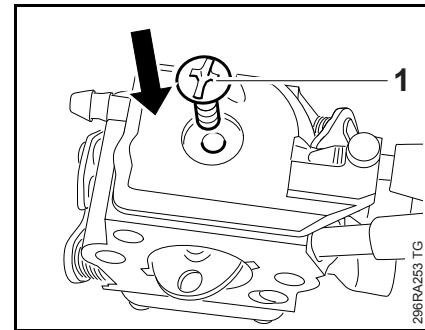

- Check that diaphragm and gasket are properly seated.
- Insert and tighten down the screw (1) firmly.
- Reassemble all other parts in the reverse sequence.

10.4.4 Throttle Lever / Rotary Knob

- Remove the carburetor,  10.3

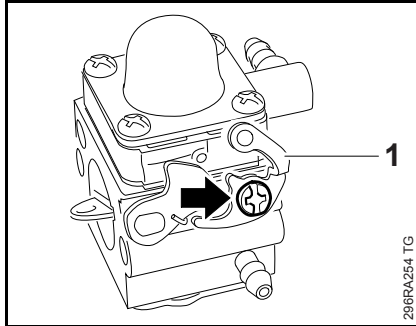

- Take out the screw (arrow).
- Pull off the throttle lever (1).

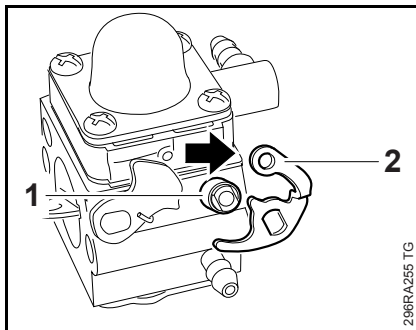

Make sure the spacer sleeve (1) is in place.

- Position the throttle lever (2) so that pin (arrow) faces up.

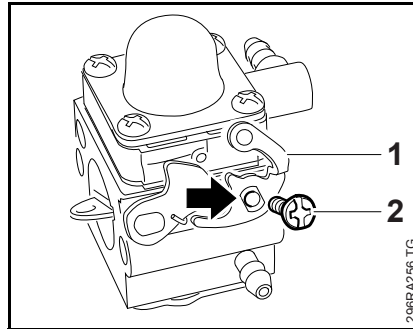

- Push the throttle lever (1) on to the end of the throttle shaft (arrow).
- Insert and tighten down the screw (2) firmly.

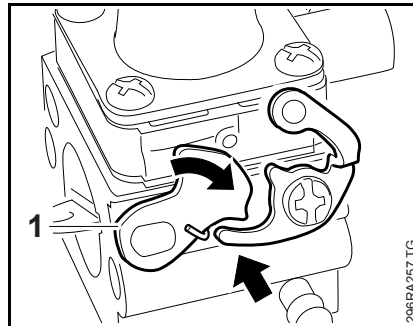

- Check operation
- Rotate the choke shaft. The lever (1) must engage the throttle lever (arrow).

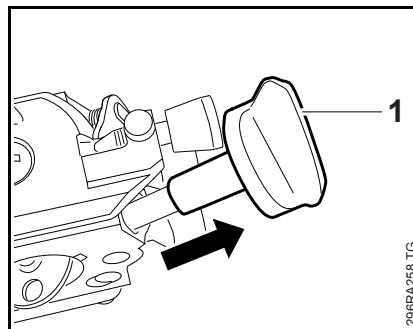

- Pull off the choke knob (1).

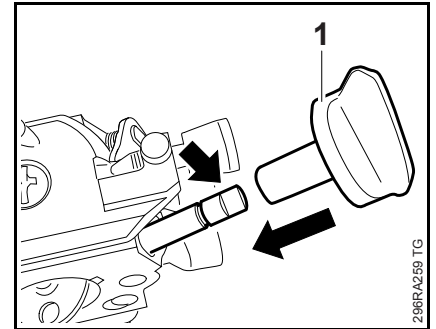

- Position the choke knob (1) so that the flat in the knob's bore lines up with the flat side (arrow) of the choke shaft.
- Push the choke knob (1) on to the choke shaft until it snaps into position.
- Reassemble all other parts in the reverse sequence.

10.4.5 Adjusting Screws

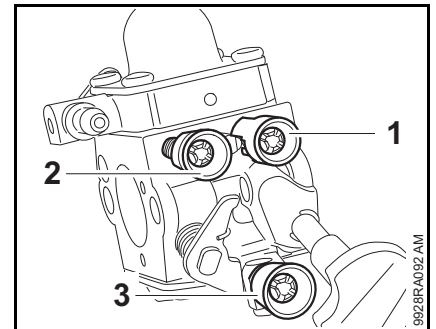

There are three adjusting screws on the carburetor:

- H** = high speed screw (1)
- L** = low speed screw (2)
- LA** = idle speed screw (3)

If the carburetor cannot be adjusted properly, the problem may be the adjusting screws.

The high speed screw **H** has a limiter cap, which has to be removed before the screw is removed.

Do not re-install used caps – always fit new caps.

- Remove the fan housing,  7.2

It is not necessary to remove the carburetor to remove and install the adjusting screws. For the sake of clarity, however, the illustrations show the carburetor removed from the machine.

- See also carburetor troubleshooting,  4.4

Low speed screw

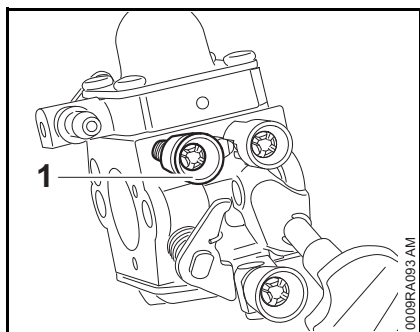

- Take out the low speed screw L (1).

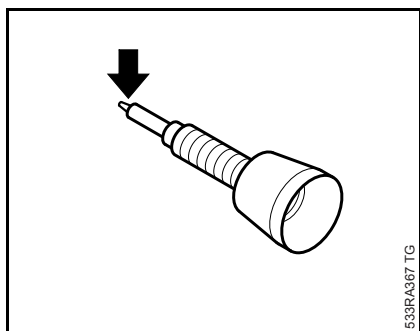

- Inspect the tip (arrow) for damage or wear and replace the low speed screw (L) if necessary.

Installing

- Carefully turn the low speed screw (L) clockwise as far as stop.
- Carry out the basic setting,  10.5.1

High speed screw

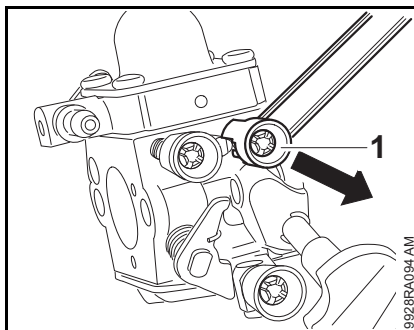

- Use special tool 5910 890 4501 to pry the limiter cap (1) off the high speed screw (H).

Do not re-install a used cap – always fit a new cap.

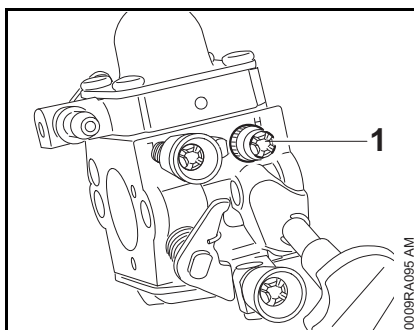

- Take out the high speed screw H (1).

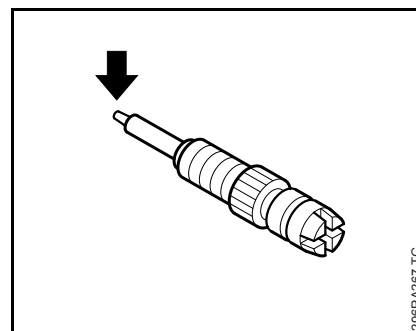

- Inspect the tip (arrow) for damage or wear and replace the high speed screw (H) if necessary.

Installing

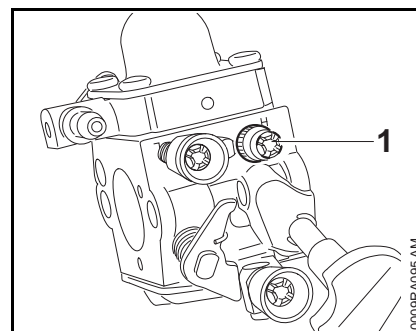

- Carefully turn the high speed screw H (1) clockwise as far as stop.

Pre-installing limiter cap

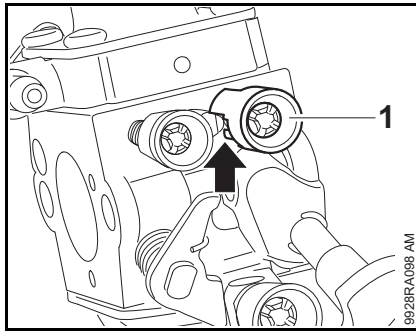

High speed screw H

Always use a new limiter cap and position it so that the long part of the cap butts against the underside of the stop (arrow). Only then may it be pushed on to the high speed screw.

- Push the limiter cap (1) onto the low speed screw as far as the first detent
– the limiter cap is thus preassembled.
- Carry out the basic setting,  10.5.1

10.5 Adjusting the Carburetor

10.5.1 Basic Setting

The basic setting is necessary only if the high speed screw (H) or low speed screw (L) has to be replaced, the limiter cap has been removed or after cleaning the carburetor.

Do not re-install used caps – always fit new caps.

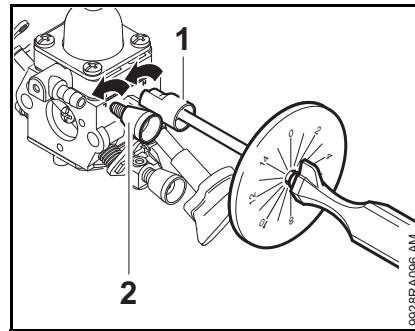

Initial adjustment of the high speed screw (H) can now be carried out.

- Use screwdriver 5910 890 2305
– the setting disk 5910 893 6600 can be fitted on the screwdriver to simplify adjustments.

Starting with the screws against their seats, rotate the low speed screw (L) and the high speed screw (H) counterclockwise.

- Turn the high speed screw H (1) 1 1/2 (24/16) turns. Turn the low speed screw L (2) 1 (16/16) turn.

This completes initial adjustment of the high speed screw (H) and the low speed screw (L).

The air filter must be installed.

- Start the engine and warm it up for 1 minute at full throttle.

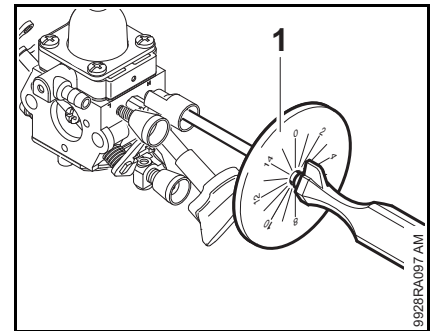

- Push screwdriver (1) 5910 890 2305 into the adjusting screws (arrow).

Adjust idle speed with a tachometer.

- 1 Adjust engine speed with idle speed screw (LA) to 2,500 rpm.
- 2 Turn the low speed screw (L) clockwise or counterclockwise to obtain the maximum engine speed.

If this speed is higher than 2,700 rpm, abort the procedure and start again with step 1.

- 3 If the maximum speed of 2,700 rpm is reached, turn the low speed screw (L) counterclockwise until a speed of 2,500 rpm is obtained

Installing limiter cap

After completing the basic setting, push the limiter cap onto the adjusting screw as follows:

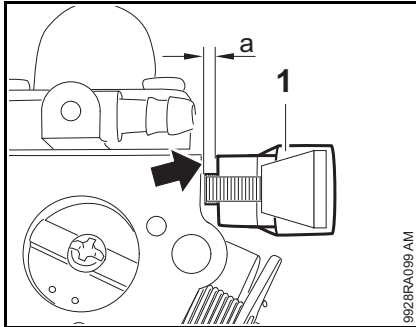

- Do not push the limiter cap (1) up against the carburetor body since it will otherwise be damaged. Clearance 'a' (arrow) must be at least 1 mm.

The movement of the high speed screw (H) is now limited.

The standard setting is obtained by turning the high speed screw (H) counterclockwise until it snaps lightly into position.

The basic setting of the high speed screw (H) is now fixed.

10.5.2 Standard Setting

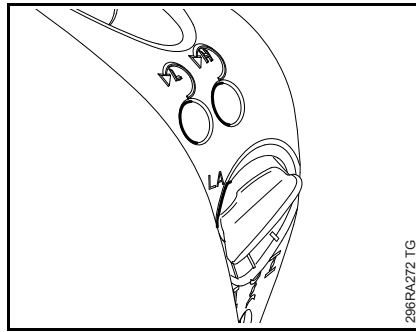

The limiter cap must not be removed for the standard setting.

Always perform the following steps before carrying out any adjustments:

- Troubleshooting, 4.4
- Shut off the engine
- Remove the blower tube.
- Inspect the spark arresting screen (if fitted) and clean or replace if necessary, 5.1
- Check the air filter and clean or replace if necessary, 10.1
- Turn the high speed screw (H) slowly counterclockwise as far as stop, but not more than a **3/4 turn**.
- Turn the low speed screw (L) slowly clockwise as far as stop – then open it 1 full turn counterclockwise.
- Start the machine and warm up the engine.
- Check engine running behavior – the engine must accelerate and idle smoothly.

10.5.3 Adjusting Engine Idle Speed

Engine stops while idling:

- Carry out standard setting, 10.5.2
- Turn the idle speed screw (LA) slowly clockwise until the engine runs smoothly.

Erratic idling behavior, engine stops even though setting of idle speed screw (LA) has been corrected, poor acceleration

Idle setting too lean.

- Warm up the engine.
- Turn the low speed screw (L) counterclockwise until the engine runs and accelerates smoothly.

It is usually necessary to change the setting of the idle speed screw (LA) after corrections to the low speed screw (L).

Fine-tuning for operation at high altitude or sea level

A minor correction **may** be necessary if engine performance is not satisfactory at high altitude or sea level.

- Check standard setting.
- Warm up the engine.

At high altitude



- Turn the high speed screw (H) clockwise (leaner) – no further than stop.

If the setting is made too lean there is a risk of engine damage as a result of lack of lubrication and overheating.

At sea level



- Turn the high speed screw (H) counterclockwise (richer) – no further than stop.

Turn the adjusting screws only very slightly. Even minor adjustments can noticeably affect engine running behavior.

If the adjustments produce no improvement, see the troubleshooting charts for the ignition system,  4.3, carburetor and engine,  4.4,  4.5.

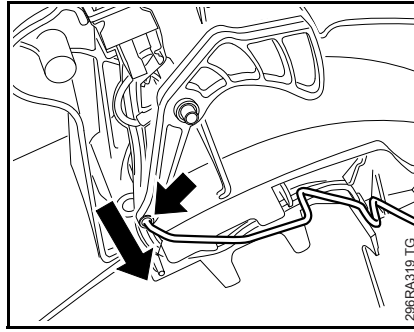
10.6 Throttle Rod



- Remove the fan housing,  7.2
- Remove the handle molding,  9.3,  9.4
- Disconnect the throttle rod from the trigger (arrow).

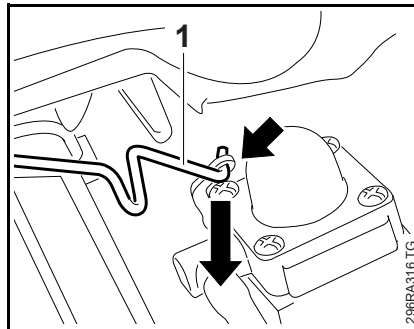

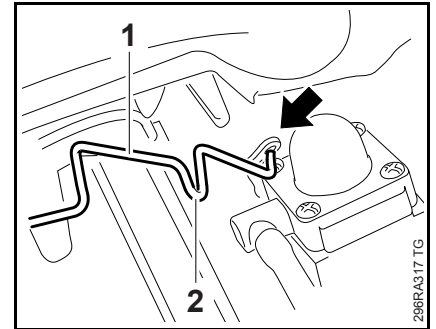

- Disconnect the throttle rod (1) from the lever (arrow) on the carburetor.
- Check the throttle rod and replace if necessary



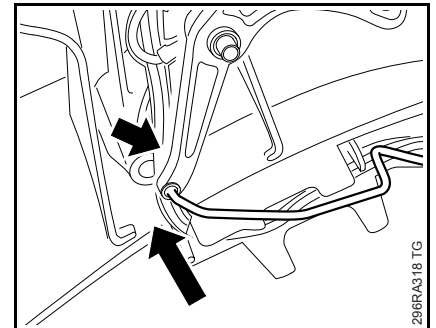

- Position the throttle rod (1) so that the bend (2) points towards the carburetor.
- Attach the throttle rod (1) to the lever (arrow) on the carburetor.



- Attach the throttle rod to the trigger (arrow).
- Fit the handle molding,  9.3,  9.4
- Check operation
- Reassemble all other parts in the reverse sequence.

10.7 Spacer Flange Removing and Installing

A damaged spacer flange can result in engine running problems.

- Troubleshooting,  4.5
- Remove the carburetor,  10.3

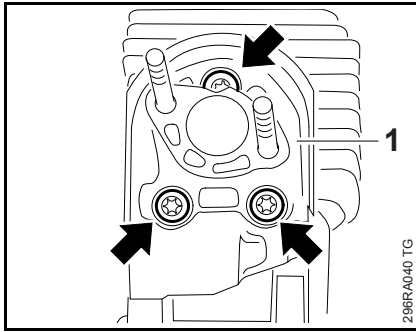

- Take out the screws (arrows).
- Remove the spacer flange (1).

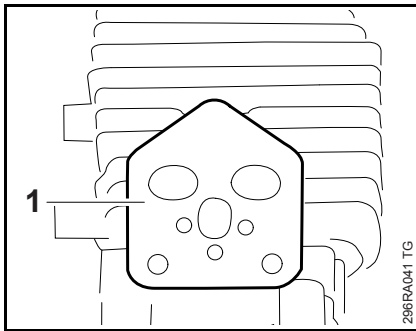

- Remove the gasket (1).

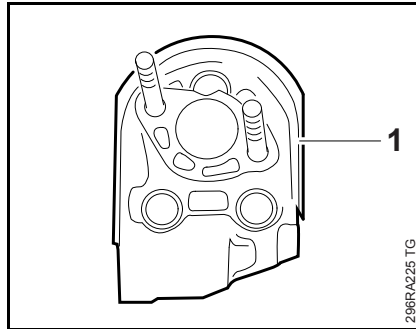

- Inspect the spacer flange (1) and replace it if necessary – even very minor damage can result in engine running problems,  4.5

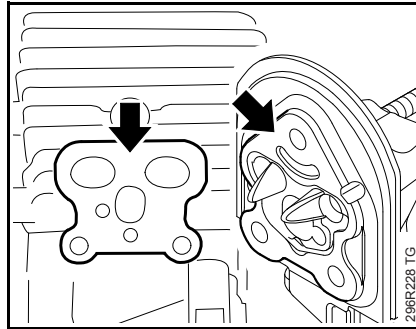

- Check and clean the sealing faces (arrows) on the cylinder and spacer flange,  13

The sealing faces must be clean and in perfect condition. Always replace components with damaged sealing faces.

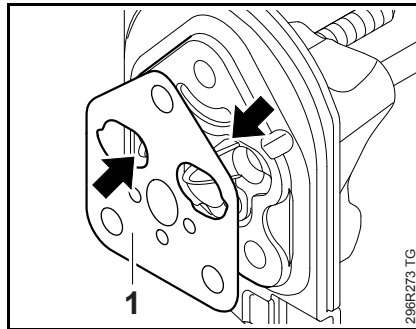

- Fit the new gasket (1) over the guides (arrows) on the spacer flange.

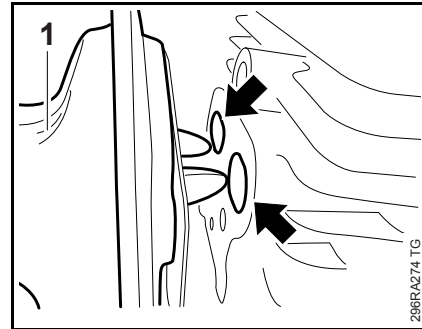

- Position the spacer flange (1) with gasket against the cylinder intake port so the guides engage the openings (arrows).

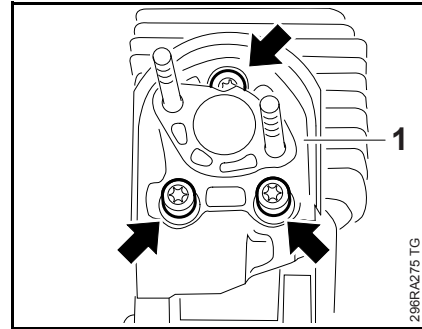



- Fit the screws (arrows).
- Check that gasket is properly seated.
- Insert the screws and tighten them down firmly.
- Reassemble all other parts in the reverse sequence.
- Tightening torques,  3.4

10.8 Tank Vent

10.8.1 Testing

If problems occur on the carburetor or the fuel supply system, also check and clean the tank vent and replace it if necessary. Check function by performing pressure and vacuum tests on the tank via the fuel hose.

- Open the fuel tank cap and drain the fuel tank,  1
- Close the tank cap.
- Remove the carburetor,  10.3

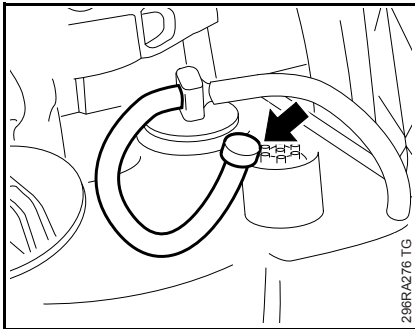

- Disconnect the fuel hoses from the carburetor and push them on to the stubs on the connector.

- Seal one fuel hose (arrow) with a plug.

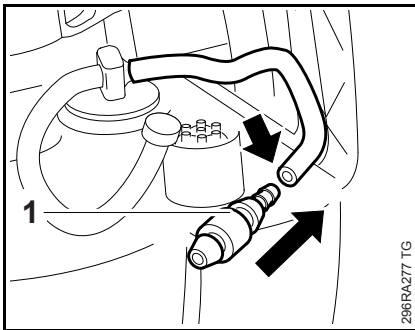

- Push the nipple (1) 0000 855 9200 into the fuel hose (arrow).

Vacuum test

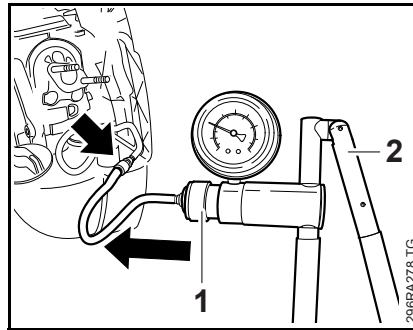

- Push the ring (1) to the left and connect the pump (2) 0000 850 1300 to the nipple (arrow)
 - subject the fuel tank to a vacuum.

Equalization of pressure takes place via the tank vent. There must be no buildup of vacuum in the tank.

- Clean the area around the tank vent.
- If necessary, install a new tank vent or tank,  10.8

Pressure test

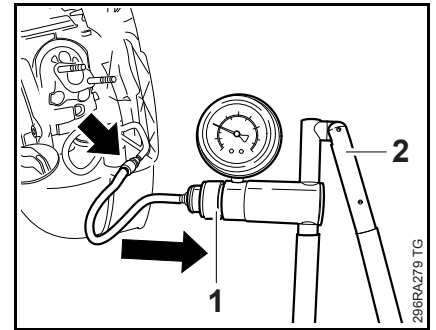

- Push the ring (1) to the right and connect the pump (2) 0000 850 1300 to the nipple (arrow) – pressurize the fuel tank.
 - Operate the pump until the pressure gauge indicates a pressure of 0.5 bar. If this pressure remains constant for at least 20 seconds, the tank, including the tank vent, is airtight. If the pressure drops, the leak must be located and the faulty part replaced.

Install new fuel hoses after completing the test.

Take care not to damage the new fuel hoses.

- Reassemble in the reverse sequence.

10.8.2 Removing and Installing

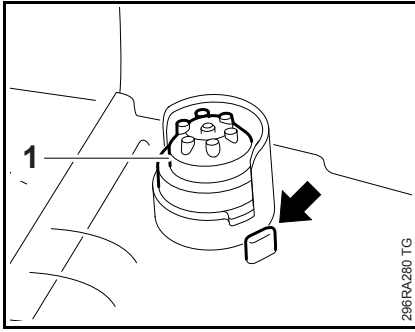

- Remove the fan housing, [7.2](#)
- Remove the air filter, [10.1](#)
- Pry the tank vent (1) out of its seat using the rib (arrow) for leverage.

Always install a new tank vent.

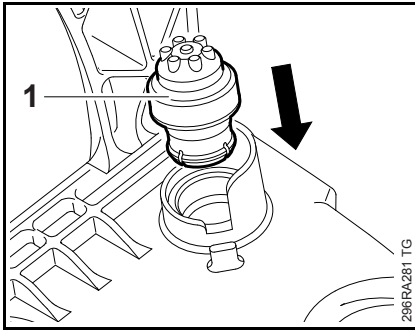

- Push the new tank vent (1) into the fuel tank bore until it snaps into position.
- Reassemble all other parts in the reverse sequence.

10.9 Fuel intake

10.9.1 Pickup Body

Any impurities mixed with the fuel are retained by the pickup body (filter). The fine pores of the filter eventually become clogged with minute particles of dirt. This restricts the passage of fuel and results in fuel starvation.

In the event of problems with the fuel supply system, always check the fuel tank and the pickup body first.

- Troubleshooting, [4.4](#)

Do not use pliers or other pointed or sharp-edged tools.

Clean the fuel tank if necessary.

- Open the tank cap and drain the tank.
- Pour a small amount of clean gasoline into the tank. Close the tank and shake the saw vigorously.
- Open the tank again and drain it.

Dispose of fuel properly in accordance with environmental requirements.

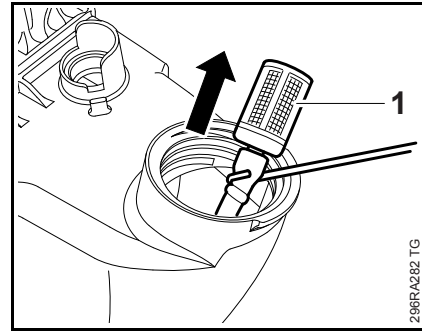

- Open the tank cap.
- Use hook 5910 893 8800 to remove the pickup body (1) from the fuel tank.

Do not overstretch the fuel hose.

- Pull the pickup body (1) off the fuel hose. Inspect it and clean or replace if necessary.
- Reassemble in the reverse sequence.

10.9.2 Fuel Hoses

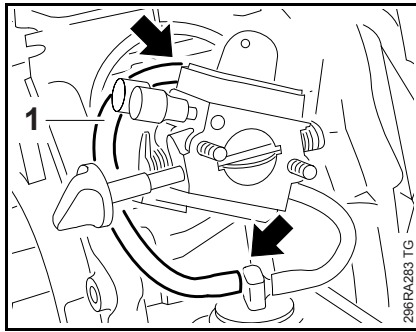

- Remove the fan housing, 7.2
- Remove the filter housing, 10.2

Before removing the fuel hoses, check them to see if they need to be replaced.

Disconnect the fuel hoses only when the tank cap is open.

- Disconnect the fuel return hose (1) from the carburetor and connector (arrows).

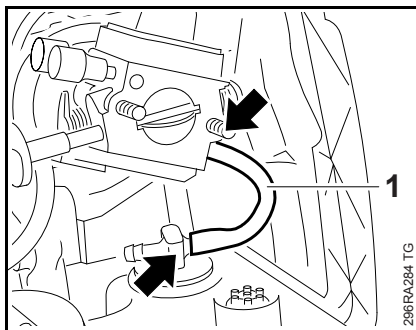

- Disconnect the fuel suction hose (1) from the carburetor and connector (arrows).

Install the new fuel hoses.

Take care not to damage the new fuel hoses.

- Reassemble in the reverse sequence.

Fuel intake

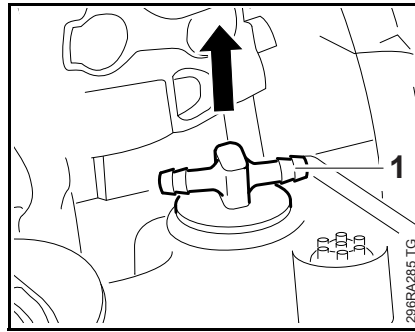

- Remove the carburetor, 10.3
- Pry out the connector (1).

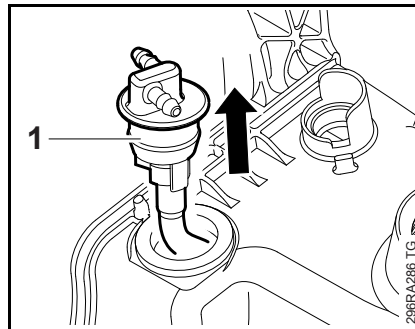

- Pull the connector (1) with fuel hose and pickup body out of the fuel tank.

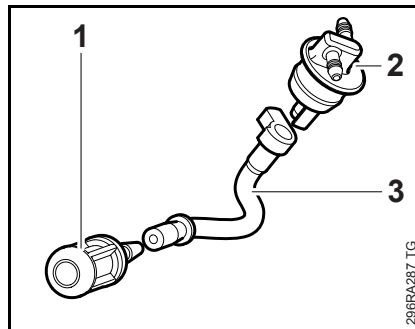

- Pull the pickup body (1) and connector (2) off the fuel hose (3).
- Check the individual parts and replace if necessary.

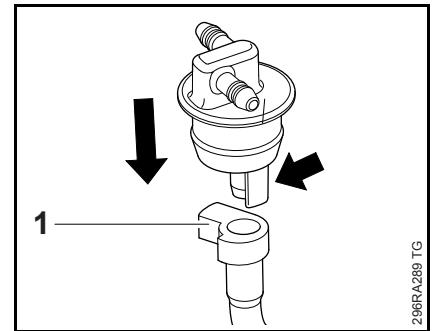

- Coat the stub with STIHL press fluid, 13
- Push the fuel hose (1) on to the connector's nipple as far as stop, making sure the shoulder (arrow) engages properly.

The fuel hose must be pushed fully home.

- Fit the pickup body on the fuel hose.

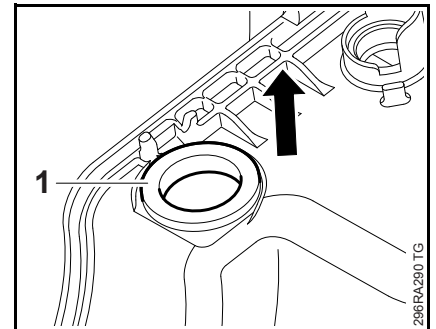

- Pry out the grommet (1).
- Inspect the grommet and replace if necessary
- Reassemble in the reverse sequence.

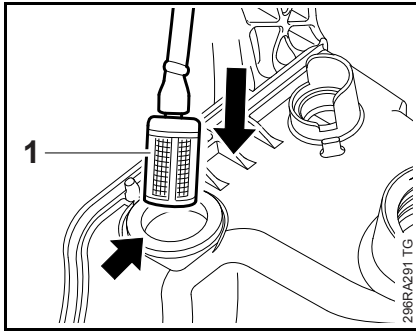

- Fit the fuel hose (1) with pickup body through the bore (arrow) in the fuel tank.

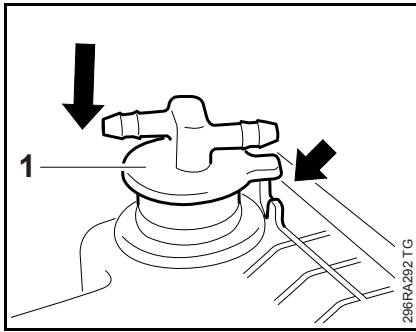

- Coat the connector with STIHL press fluid, 13
- Line up the connector (1) and push it into the bore until the tab engages the recess (arrow) and locates against the housing.

Install the new fuel hoses.

Take care not to damage the new fuel hoses.

- Push the fuel hoses on to the stubs of the connector (1) and install the carburetor, 10.3
- Reassemble all other parts in the reverse sequence.
- Tightening torques, 3.4

10.9.3 Fuel Tank Cap

See instruction manual.

- Open the tank cap.

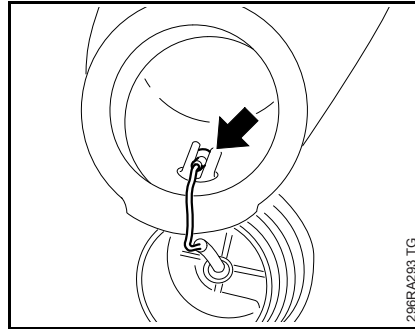

- Disconnect nipple on tank cap cord from the slot (arrow) inside the tank.
- Inspect the tank cap. Install new sealing ring or tank cap if necessary.
- Reassemble in the reverse sequence.
- Check for leaks.

11. Blower and Vacuum Attachment

11.1 Intake Screen

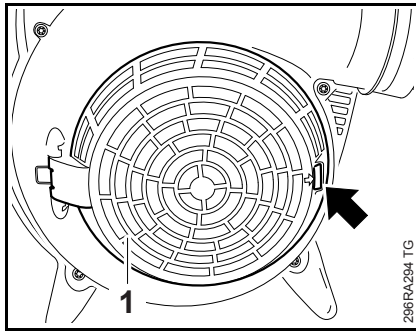

- Ease the retaining tab (arrow) to one side and unlock the intake screen (1).

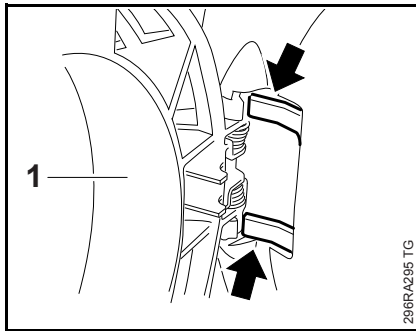

- Open the intake screen (1).
- Press down the tabs (arrows).

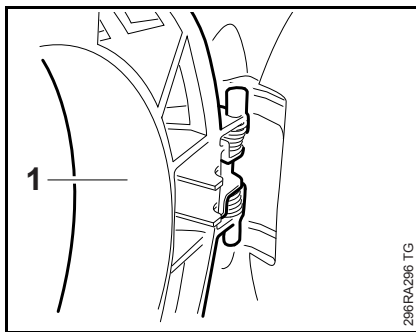

- Carefully pull pivot pins of intake screen (1) out of their mounts – the torsion spring may pop out.
- Remove the intake screen (1) – the torsion spring may fall out.

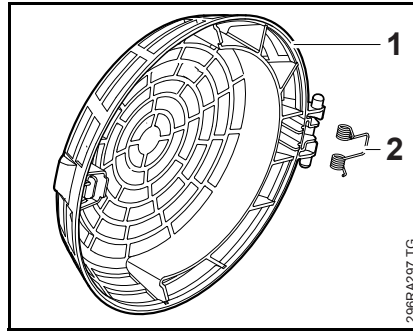

- Inspect the outer blower housing and replace if necessary, 11.2
- Check the intake screen (1) and torsion spring (2) and replace if necessary

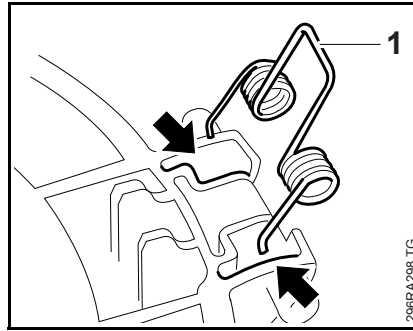

- Position legs of torsion spring (1) in the recesses (arrows).

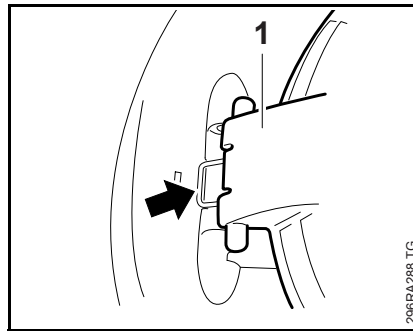

- Position intake screen (1) and torsion spring (arrow) against the outer blower housing.

The torsion spring may pop out.

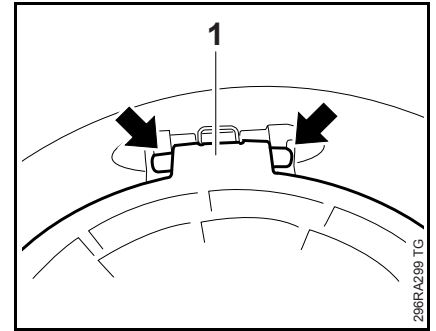

- Apply intake screen's pivot pins (arrows) to the tabs on the outer blower housing and press down.
- With the intake screen (1) still depressed, push it into the mounts to engage the pivot pins in position.

The torsion spring may pop out.

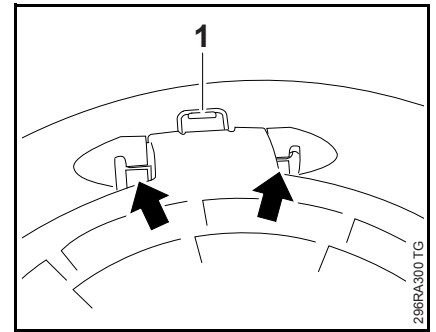

- Check installed position of intake screen.

The torsion spring must be over the lug (1) and the intake screen's pivot pins must be behind the tabs (arrows) on the outer blower housing.

Spring force now holds the intake screen against the outer blower housing.

- Press the intake screen against the outer blower housing until it snaps into position.

11.2 Blower Wheel

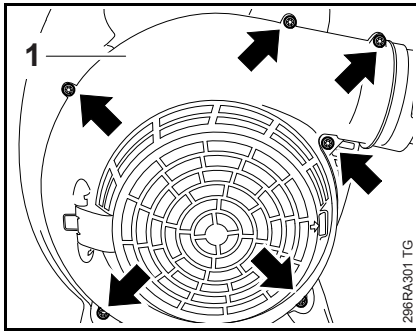

- Take out the screws (arrows).
- Lift away the blower housing (1).

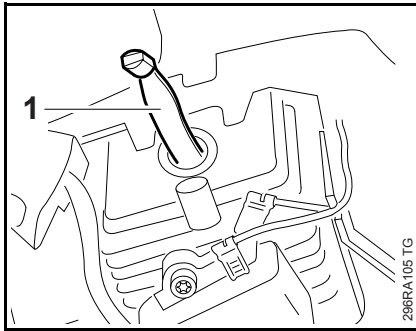

- Use locking strip (1) to block the piston, 6.5

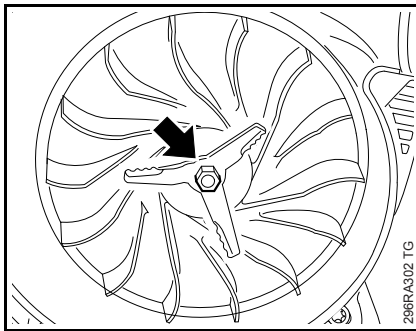

- Unscrew the nut (arrow) – it has a left-hand thread.

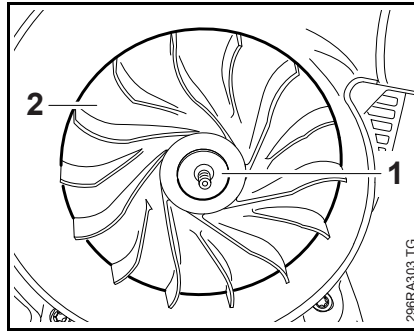

- Remove the washer (1).
- Pull off the blower wheel (2).

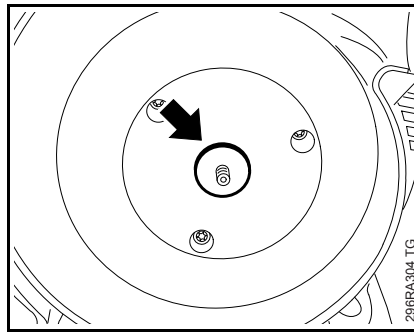

- Remove the washer (arrow).
- Check the individual parts and replace if necessary.

The blower wheel must not be cracked or damaged in any other way.

Damage on the blower wheel can result in consequential damage – bearing damage due to out of balance, or the high centrifugal forces may cause the blower wheel to shatter.

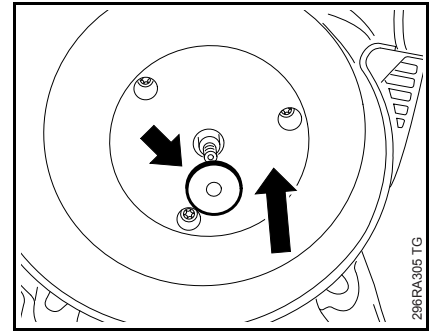

- Fit the washer (arrow).
- Push the blower wheel into position.

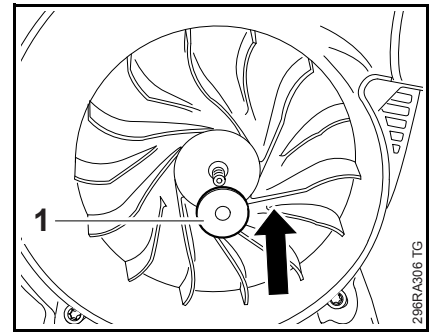

- Fit the washer (1).
- Fit the nut and tighten it down firmly.

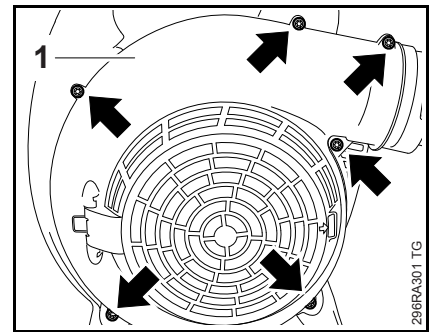

- Place the outer blower housing (1) in position.
- Insert the screws (arrows) and tighten them down firmly.
- Tightening torques, 3.4

11.3 Removing and Installing Blower Housing on Models SH 56, SH 56 C, BG 56, BG 56 C, BG 66

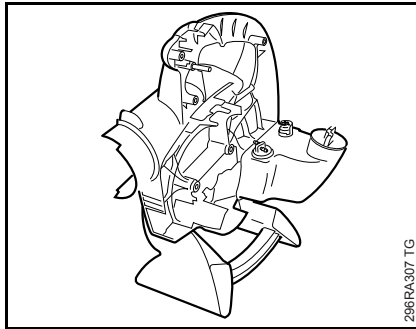

- Remove the blower wheel, [11.2](#)
- Remove the engine, [5.4](#)
- Remove the throttle trigger, [9.3](#)
- Remove the short circuit wire, [6.6.2](#)
- Inspect the blower housing and replace if necessary

A replacement blower housing comes with the pickup body and fuel hoses, tank vent and tank cap preassembled, i.e. these parts do not need to be transferred from the old housing.

- Reassemble in the reverse sequence.
- Tightening torques, [3.4](#)

11.3.1 Removing and Installing Blower Housing on Models SH 86, SH 86 C, BG 66 C, BG 86, BG 86 C

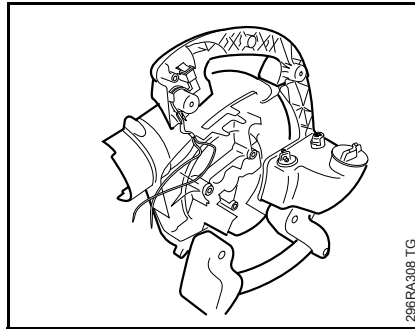

- Remove the blower wheel, [11.2](#)
- Remove the engine, [5.4](#)
- Remove the throttle trigger, [9.3](#)

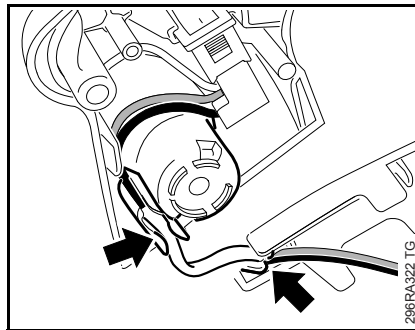

- Disconnect the wiring harness (arrows), [6.6.2](#)

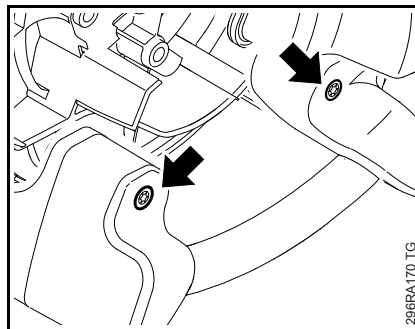

- Take out the screws (arrows).

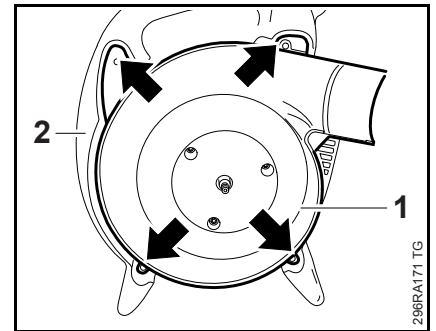

- Pull the blower housing (1) off the handle frame (2) – this releases the anti-vibration springs (arrows) from their seats.
- Lift away the blower housing (1).

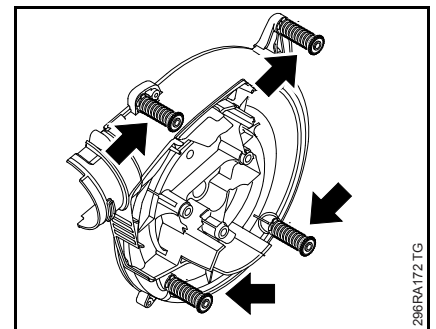

- Inspect the blower housing and replace if necessary

A replacement blower housing comes with preassembled anti-vibration springs (arrows).

- Push the anti-vibration springs (arrows) of blower housing into their seats in the handle housing until they snap into position, [8.1](#)
- Reassemble all other parts in the reverse sequence.
- Tightening torques, [3.4](#)

11.3.2 Removing and Installing Handle Housing on Models SH 86, SH 86 C, BG 66 C, BG 86, BG 86 C

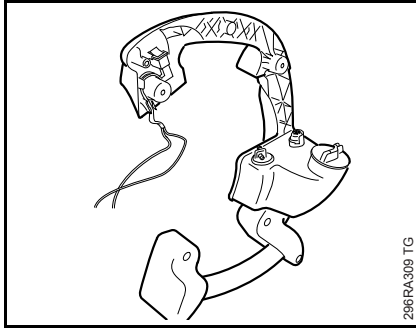

296RA309 TG

- Remove the blower housing, 11.3.1
- Remove the handle, 8.2
- Check the handle housing and replace if necessary

A replacement handle housing comes with the pickup body and fuel hoses, tank vent and tank cap preassembled, i.e. these parts do not need to be transferred from the old housing.

- Check the short circuit wire with stop switch and replace if necessary, 6.6.2
- Inspect outer handle molding and replace if necessary, 9.4
- Reassemble in the reverse sequence.
- Tightening torques, 3.4

11.4 Blower Tube – BG Models

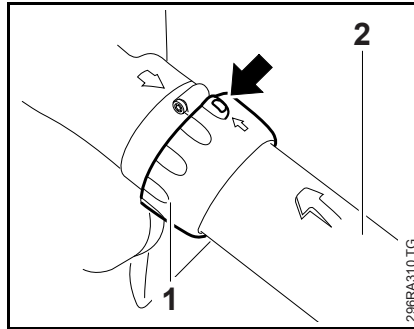

296RA310 TG

- Unlock the union nut (1) through the opening (arrow) and turn it counterclockwise.
- Pull off the blower tube (2).

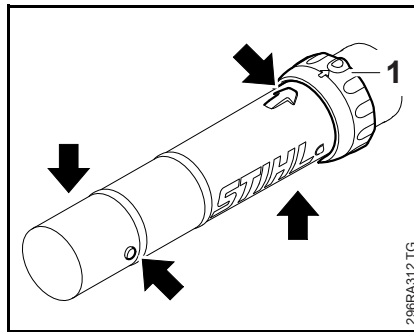

296RA312 TG

- Pull off the union nut (1) over the raised moldings (arrows).
- Check the individual parts and replace if necessary.

A replacement blower tube comes with the union nut preassembled.

- Reassemble in the reverse sequence.

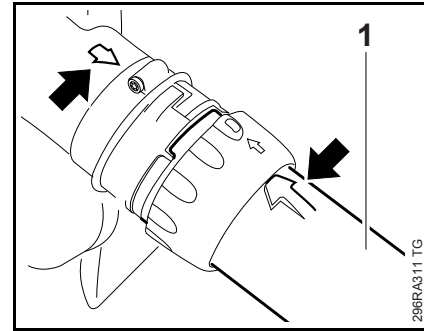

296RA311 TG

- Position the blower tube (1) so that the marks (arrows) are in alignment.
- Push the blower tube onto the blower housing stub.

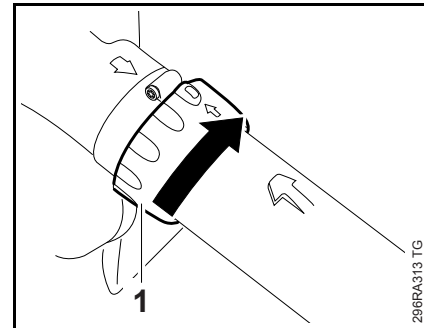

296RA313 TG

- Turn the union nut (1) clockwise until it snaps into position.

11.5 Elbow – SH Models

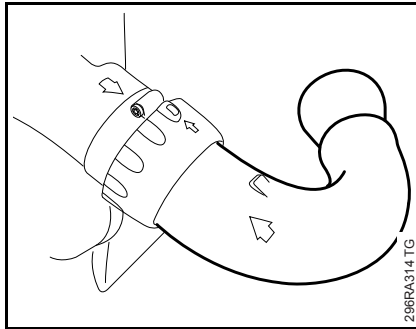

The procedure for removing and installing the elbow is the same as for the blower tube,  11.4.

The elbow and union nut form a single unit and cannot be taken apart.

11.6 Suction Tube – SH Models

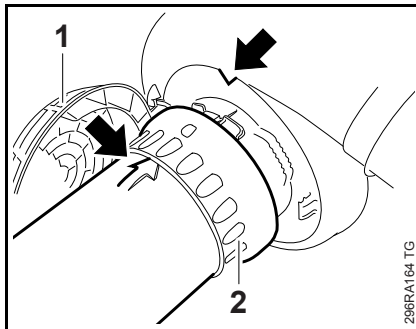

– Open the intake screen (1),  11.1

● Position the suction tube (2) so that the marks (arrows) are in alignment.

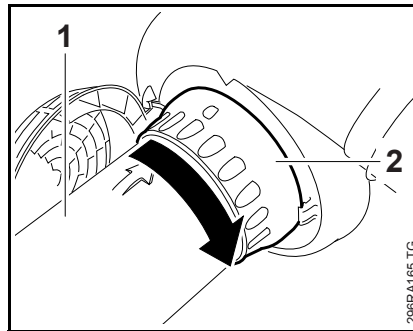

– Push the suction tube (1) onto the intake stub.

● Slide the union nut (2) into place and turn it clockwise until the latch engages, then continue turning it until there is noticeable resistance and it is firmly seated.

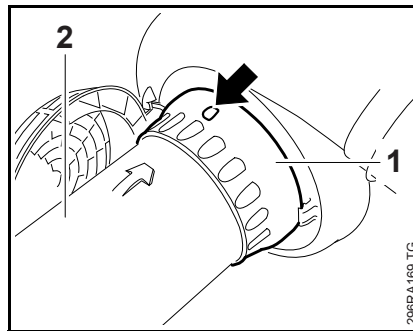

– Unscrew the union nut (1) counterclockwise until it is against the latch.

● Unlock the union nut (1) through the opening (arrow) and turn it counterclockwise.

– Hold the intake screen steady and pull off the suction tube (2).

12. Special Servicing Tools

New Special Tools

No.	Part Name	Part No.	Application	Rem.
1	Test flange	5910 850 4200	Leakage test	
2	Puller	5910 893 0801	Releasing flywheel	1
3	Sleeve	5910 893 1708	Sleeve (with 20° chamfer) for installing tool 8	

Existing Special Tools

No.	Part Name	Part No.	Application	Rem.
1	Carburetor and engine tester	0000 850 1300	Testing engine and carburetor for leaks	
2	Sealing plate	0000 855 8106	Sealing the exhaust port	
	- Hose for leakage test	1110 141 8600	Testing carburetor for leaks	
	- Nipple	0000 855 9200	Testing carburetor for leaks	
3	Puller	5910 890 4501	Removing limiter caps	
4	Use screwdriver	5910 890 2305	Adjusting the carburetor	
	- Setting disk	5910 893 6600	Add-on for screwdriver (adjusting carburetor)	
5	Socket DIN 3124, 13 mm	5910 893 5608	Removing flywheel nut	
6	Setting gauge	1127 890 6400	Adjusting air gap between the ignition module and flywheel	
7	Ignition system tester, ZAT 4	5910 850 4503	Testing ignition system	
8	Ignition system tester, ZAT 3	5910 850 4520	Testing ignition system	
9	Puller	5910 890 4400	Removing oil seals	
	- Jaws (No. 3.1)	0000 893 3706	Removing oil seal(s)	
	- Jaws (No. 2)	0000 893 3700	Holding the engine pan	
10	Threaded bushing	1108 893 4500	Holding engine pan with puller 5910 890 4400	
11	Press sleeve	1121 893 2400	Installing oil seal	
12	Locking strip	0000 893 5904	Blocking the crankshaft	
13	Installing sleeve	4119 893 4600	Protects oil seal at fan side	
14	Assembly drift	1130 893 4700	Removing and installing piston pin	
15	Installing tool 8	5910 890 2208	Installing hookless snap ring in piston	
16	Installing tool	1116 893 4800	Rewind spring	
17	Installing tool	5910 890 2204	Installing and flaring rope guide bushing	
18	Hook	5910 893 8800	Removing pickup body	
19	Torque wrench	5910 890 0302	0.5 to 18 Nm	
20	Torque wrench	5910 890 0312	6 to 80 Nm	

No.	Part Name	Part No.	Application	Rem.
21	Screwdriver bit, T 27 x 125	0812 542 2104	Removing and installing spline socket screws with electric or pneumatic screwdrivers; tighten down screws with torque wrench (4 mm)	1
22	Screwdriver bit, T 27 x 150	5910 890 2400	IS-P screws (4 mm)	1
23	Crimping tool	5910 890 8210	Attaching connectors to electrical wires	

Remarks:

1) Use for releasing only.

13. Servicing Aids

No.	Part Name	Part No.	Application
1	Lubricating grease (225 g tube)	0781 120 1111	Oil seals, sliding and bearing points
2	STIHL special lubricant	0781 417 1315	Bearing bore in rope rotor, rewind spring in fan housing
3	Press Fluid OH 723	0781 957 9000	Rubber elements, fuel hoses, etc.
4	STIHL multipurpose grease	0781 120 1109	High voltage output on ignition module
5	Dirko HT red sealant	0783 830 2000	Engine pan, oil seals (outside)
6	Medium-strength threadlocking adhesive (Loctite 242)	0786 111 2101	
7	High-strength threadlocking adhesive (Loctite 270)	0786 111 2109	
8	High-strength threadlocking adhesive (Loctite 648)	0786 111 2117	
9	Standard commercial solvent-based degreasant containing no chlorinated or halogenated hydrocarbons		Cleaning sealing faces and carburetor, crankshaft stubs and flywheel taper

englisch / english

0455 296 0123. M0. F11. xxx.