

STIHL[®]

STIHL FS 120, 120 R, 250

Instruction Manual



Contents

Guide to Using this Manual	2	Inspections and Maintenance by Dealer	38
Safety Precautions and Working Techniques	2	Maintenance and Care	39
Approved Combinations of Cutting Attachment, Deflector, Handle and Harness	12	Minimize Wear and Avoid Damage	41
Approved Power Tool Attachments	13	Main Parts	42
Mounting the Bike Handle	14	Specifications	44
Mounting the Loop Handle	15	Maintenance and Repairs	45
Adjusting the Throttle Cable	17	Disposal	45
Fitting the Carrying Ring	17	EC Declaration of Conformity	46
Mounting the deflector	18		
Mounting the Cutting Attachment	19		
Fuel	21		
Fueling	22		
Fitting the Harness	23		
Balancing the Machine	25		
Starting / Stopping the Engine	25		
Transporting the Unit	28		
Operating Instructions	30		
Air filter	30		
Adjusting the Carburetor	31		
Spark Plug	32		
Engine Running Behavior	33		
Lubricating the Gearbox	33		
Replacing the Starter Rope and Rewind Spring	34		
Storing the Machine	36		
Sharpening Metal Cutting Blades	36		
Maintaining the Mowing Head	37		
Inspection and Maintenance by User	38		

Dear Customer,

Thank you for choosing a quality engineered STIHL product.

It has been built using modern production techniques and comprehensive quality assurance. Every effort has been made to ensure your satisfaction and trouble-free use of the product.

Please contact your dealer or our sales company if you have any queries concerning this product.

Your



Dr. Nikolas Stihl

STIHL®

FS 120, FS 120 R, FS 250

This instruction manual is protected by copyright. All rights reserved, especially the rights to reproduce, translate and process with electronic systems.

Guide to Using this Manual

Pictograms

The meanings of the pictograms attached to the machine are explained in this manual.

Depending on the model concerned, the following pictograms may be attached to your machine.



Fuel tank; fuel mixture of gasoline and engine oil

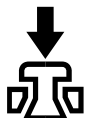

Operate decompression valve



Manual fuel pump

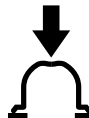

Operate manual fuel pump

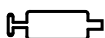

Tube of grease



Intake air: Summer operation



Intake air: Winter operation



Handle heating

Symbols in text



WARNING

Warning where there is a risk of an accident or personal injury or serious damage to property.



NOTICE

Caution where there is a risk of damaging the machine or its individual components.

Engineering improvements

STIHL's philosophy is to continually improve all of its products. For this reason we may modify the design, engineering and appearance of our products periodically.

Therefore, some changes, modifications and improvements may not be covered in this manual.

Safety Precautions and Working Techniques



Some special safety precautions must be observed to reduce the risk of personal injury when operating this power tool because of the very high speed of its cutting attachment.



It is important that you read the instruction manual before first use and keep it in a safe place for future reference. Non-observance of the instruction manual may result in serious or even fatal injury.

Observe all applicable local safety regulations, standards and ordinances.

If you have not used this type of power tool before: Have your dealer or other experienced user show you how to operate your machine or attend a special course in its operation.

Minors should never be allowed to use a power tool.

Keep bystanders, especially children, and animals away from the work area.

When the power tool is not in use, shut it off so that it does not endanger others. Secure it against unauthorized use.

The user is responsible for avoiding injury to third parties or damage to their property.

Do not lend or rent your power tool without the instruction manual. Be sure that anyone using it understands the information contained in this manual.

The use of noise emitting power tools may be restricted to certain times by national or local regulations.

To operate the power tool you must be rested, in good physical condition and mental health.

If you have any condition that might be aggravated by strenuous work, check with your doctor before operating a power tool.

Persons with pacemakers only: The ignition system of your power tool produces an electromagnetic field of a very low intensity. This field may interfere with some pacemakers. STIHL recommends that persons with pacemakers consult their physician and the pacemaker manufacturer to reduce any health risk.

Do not operate the power tool if you are under the influence of any substance (drugs, alcohol) which might impair vision, dexterity or judgment.

Depending on the cutting attachment fitted, use your power tool only for cutting grass, wild growth, shrubs, scrub, bushes, small diameter trees and similar materials.

Do not use your power tool for any other purpose because of the **increased risk of accidents**.

Only use cutting attachments and accessories that are explicitly approved for this power tool model by STIHL or are technically identical. If you have any questions in this respect, consult a

servicing dealer. Use only high quality tools and accessories in order to avoid the risk of accidents and damage to the machine.

STIHL recommends the use of genuine STIHL tools and accessories. They are specifically designed to match the product and meet your performance requirements.

Never attempt to modify your power tool in any way since this may increase the risk of personal injury. STIHL excludes all liability for personal injury and damage to property caused while using unauthorized attachments.

Do not use a pressure washer to clean the unit. The solid jet of water may damage parts of the unit.

The deflector on this power tool cannot protect the operator from all objects thrown by the cutting attachment (stones, glass, wire, etc.). Such objects may ricochet and then hit the operator.

Clothing and Equipment

Wear proper protective clothing and equipment.



Clothing must be sturdy but allow complete freedom of movement. Wear snug-fitting clothing, an overall and jacket combination, do not wear a work coat.



Avoid clothing that could get caught on branches or brush or moving parts of the machine. Do not wear a scarf, necktie or jewelry. Tie up and confine long hair (e.g. with a hair net, cap, hard hat, etc.).



Wear steel-toed safety boots with non-slip soles.

Sturdy shoes with non-slip soles may be worn as an alternative only when using mowing heads.

WARNING



To reduce the risk of eye injuries, wear snug-fitting safety glasses in accordance with European Standard EN 166. Make sure the safety glasses are a good fit.

Wear a face shield and make sure it is a good fit. A face shield alone does not provide adequate eye protection.

Wear hearing protection, e.g. earplugs or ear muffs.

Wear a safety hard hat for thinning operations, when working in high scrub and where there is a danger of head injuries from falling objects.



Wear heavy-duty work gloves made of durable material (e.g. leather).

STIHL offers a comprehensive range of personal protective clothing and equipment.

Transporting the Power Tool

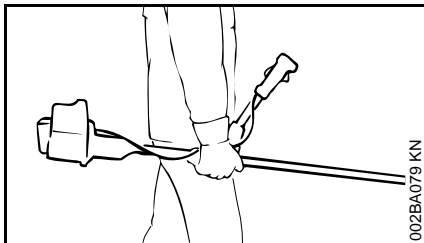
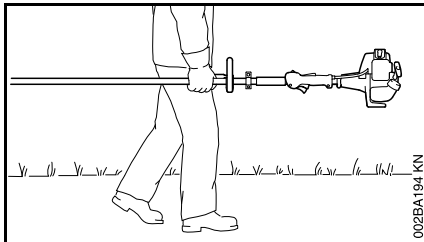

Always turn off the engine.

Carry the unit hanging from the shoulder strap or properly balanced by the drive tube.

To reduce the risk of cut injuries, fit transport guard on the cutting attachment, even when carrying the tool for short distances – see also "Transporting the Unit".



To reduce the risk of serious burn injuries, avoid touching hot parts of the machine, including the gearbox housing.

Transporting by vehicle: Properly secure your power tool to prevent turnover, fuel spillage and damage.

Fueling



Gasoline is an extremely flammable fuel. Keep clear of naked flames. Do not spill any fuel – do not smoke.

Always shut off the engine before refueling.

Do not fuel a hot engine – **fuel may spill and cause a fire.**

Open the fuel cap carefully to allow any pressure build-up in the tank to release slowly and avoid fuel spillage.

Fuel your power tool only in well-ventilated areas. If you spill fuel, wipe the machine immediately – if fuel gets on your clothing, change immediately.



After fueling, tighten down the fuel tank cap as securely as possible.

This reduces the risk of unit vibrations causing the fuel cap to loosen or come off and spill quantities of fuel.

To reduce the risk of serious or fatal burn injuries, check for fuel leakage. If fuel leakage is found, do not start or run the engine until leak is fixed.

Before Starting

Check that your power tool is properly assembled and in good condition – refer to appropriate chapters in the instruction manual.

- Check the fuel system for leaks, paying special attention to visible parts such as the tank cap, hose connections and the manual fuel pump (on machines so equipped). If there are any leaks or damage, do not start the engine – **risk of fire**. Have your machine repaired by a servicing dealer before using it again.
- Use only an approved combination of cutting attachment, deflector, handle and harness. All parts must be assembled properly and securely.
- Slide control / stop switch must move easily to **STOP** or **0**.
- Smooth action of throttle trigger lockout (if fitted) and throttle trigger – the throttle trigger must return automatically to the idle position.
- Check that the spark plug boot is secure – a loose boot may cause arcing that could ignite combustible fumes **and cause a fire**.
- Check cutting tool or attachment for correct and secure assembly and good condition.

- Check protective devices (e.g. deflector for cutting attachment, rider plate) for damage or wear. Always replace damaged parts. Do not operate your machine with a damaged deflector or worn rider plate (lettering and arrows no longer legible).
- Never attempt to modify the controls or safety devices in any way.
- Keep the handles dry and clean – free from oil and dirt – for safe control of the power tool.
- Adjust the harness and handle(s) to suit your height and reach. See chapters on "Fitting the Harness" and "Balancing the Trimmer/Brushcutter".

To reduce the risk of accidents, do not operate your power tool if it is damaged or not properly assembled.

If you use a shoulder strap or full harness: Practice removing and putting down the power tool as you would in an emergency. To avoid damage, do not throw the power tool to the ground when practicing.

Start the engine.

Start the engine at least 3 meters from the fueling spot, outdoors only.

Place the unit on firm ground in an open area. Make sure you have good balance and secure footing. Hold the unit securely. The cutting attachment must be clear of the ground and all other obstructions because it may begin to run when the engine starts.

Your power tool is a one-person unit. **To reduce the risk of injury** from thrown objects, do not allow other persons within a radius of 15 meters of your own position – even when starting.



To reduce the risk of injury, avoid contact with the cutting attachment.



Do not drop start the power tool – start the engine as described in the instruction manual. Note that the cutting attachment continues to run for a short period after you let go of the throttle trigger – **flywheel effect**.

Check idle speed setting: The cutting attachment must not rotate when the engine is idling with the throttle trigger released.

To reduce the risk of fire, keep hot exhaust gases and hot muffler away from easily combustible materials (e.g. wood chips, bark, dry grass, fuel).

Holding and Controlling the Power Tool

Always hold the power tool firmly with both hands on the handles.

Make sure you always have good balance and secure footing.

Models with bike handle

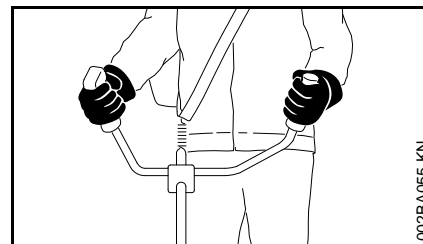

Right handle on control handle, left hand on left handle.

Models with loop handle

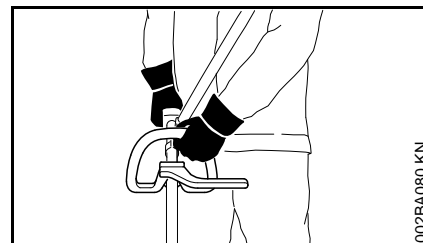

On models with a loop handle and barrier bar, left hand on loop handle, right hand on control handle, even if you are left-handed.

During Operation

Make sure you always have good balance and secure footing.

In the event of impending danger or in an emergency, switch off the engine immediately by moving the slide control / stop switch to **STOP** or **0**.

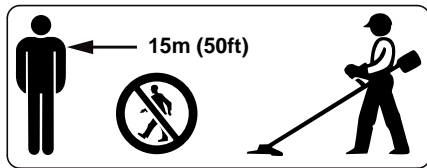

The cutting attachment may catch and fling objects a great distance and cause injury - therefore, do not allow any other persons within a radius of 15 meters of your own position. **To reduce the risk of damage to property**, also maintain this distance from other objects (vehicles, windows). Even maintaining a distance of 15 meters or more cannot exclude the potential danger.

The correct engine idle speed is important to ensure that the cutting attachment stops rotating when you let go of the throttle trigger.

Check and correct the idle speed setting regularly. If the cutting attachment continues to rotate when the engine is idling, have the machine checked by your servicing dealer. STIHL recommends an authorized STIHL servicing dealer.

Take special care in slippery conditions (ice, wet ground, snow), on slopes or uneven ground.

Watch out for obstacles: Roots and tree stumps which **could cause you to trip or stumble**.

Always stand on the ground while working, never on a ladder, work platform or any other insecure support.

Be particularly alert and cautious when wearing hearing protection because your ability to hear warnings (shouts, alarms, etc.) is restricted.

To reduce the risk of accidents, take a break in good time to avoid tiredness or exhaustion.

Work calmly and carefully – in daylight conditions and only when visibility is good. Stay alert so as not to endanger others.



Your power tool produces toxic exhaust fumes as soon as the engine is running. These fumes may be colorless and odorless and contain unburned hydrocarbons and benzol. Never run the engine indoors or in poorly ventilated locations, even if your model is equipped with a catalytic converter.

To reduce the risk of serious or fatal injury from breathing toxic fumes, ensure proper ventilation when working in trenches, hollows or other confined locations.

To reduce the risk of accidents, stop work immediately in the event of nausea, headache, visual disturbances (e.g. reduced field of vision), problems with hearing, dizziness, deterioration in ability to concentrate. Apart from other possibilities, these symptoms may be caused by an excessively high concentration of exhaust gases in the work area.

Operate your power tool so that it produces a minimum of noise and emissions – do not run the engine unnecessarily, accelerate the engine only when working.

To reduce the risk of fire, do not smoke while operating or standing near your power tool. Note that combustible fuel vapor may escape from the fuel system.

The dusts, vapor and smoke produced during operation may be dangerous to health. If the work area is very dusty or smoky, wear a respirator.

If your power tool is subjected to unusually high loads for which it was not designed (e.g. heavy impact or a fall), always check that it is in good condition before continuing work – see also "Before Starting".

Check the fuel system in particular for leaks and make sure the safety devices are working properly. Do not continue operating your power tool if it is damaged. In case of doubt, consult your servicing dealer.

Do not operate your power tool in the starting throttle position – engine speed cannot be controlled in this position.



To reduce the risk of injury from thrown objects, never operate the unit without the proper deflector for the type of cutting attachment being used.



Inspect the work area: Stones, pieces of metal or other solid objects may be thrown more than 15 meters and **cause personal injury** or damage the cutting attachment and property (e.g. parked vehicles, windows).



Special care must be taken when working in difficult, over-grown terrain.

When cutting high scrub, under bushes and hedges: Keep cutting attachment at a minimum height of 15 cm to avoid harming small animals.

Always shut off the engine before leaving the unit unattended.

Check the cutting attachment at regular short intervals during operation or immediately if there is a noticeable change in cutting behavior:

- Turn off the engine. Hold the unit firmly and wait for the cutting attachment to come to a standstill.
- Check condition and tightness, look for cracks.
- Check sharpness.
- Replace damaged or dull cutting attachments immediately, even if they have only superficial cracks.

Clean grass and plant residue off the cutting attachment mounting at regular intervals – remove any build up of material from the cutting attachment and deflector.

To **reduce the risk of injury**, shut off the engine before replacing the cutting attachment.



The gearbox becomes hot during operation. To **reduce the risk of burn injury**, do not touch the gearbox housing.

When using mowing heads

Equip the deflector with the additional components specified in the instruction manual.

Use only the deflector with properly mounted line limiting blade to ensure the mowing lines are automatically trimmed to the approved length.

To **reduce the risk of injury**, always turn off the engine before adjusting the nylon line of manually adjustable mowing heads

Using the unit with over-long nylon cutting lines reduces the engine's operating speed. The clutch then slips continuously and this causes overheating and damage to important components (e.g. clutch, polymer housing components) – **and this can increase the risk of injury** from the cutting attachment rotating while the engine is idling.

Using metal cutting attachments

STIHL recommends the use of original STIHL metal cutting attachments. They are specifically designed to match your model and meet your performance requirements.

Metal cutting attachments rotate at very high speed. The forces that occur act on the machine, the attachment and the material being cut.

Sharpen metal cutting attachments regularly as specified.

Unevenly sharpened metal cutting attachments cause out-of-balance which can impose extremely high loads on the machine and increase the **risk of breakage**.

Dull or improperly sharpened cutting edges can put a higher load on the cutting attachment and increase the **risk of injury** from cracked or broken parts.

Inspect metal cutting attachments for cracks or warping after every contact with hard objects (e.g. stones, rocks, pieces of metal). To **reduce the risk of injury**, remove burrs and other visible build-ups of material (use a file) because they may become detached and be thrown at high speed during operation.

If a rotating metal cutting attachment makes contact with a rock or other solid object there is a risk of sparking which may cause easily combustible material to catch fire under certain circumstances. Dry plants and scrub are also easily combustible, especially in hot and dry weather conditions. If there is a risk of fire, do not use metal cutting attachments near combustible materials, dry plants or scrub. Always contact your local forest authority for information on a possible fire risk.

Do not continue using or attempt to repair damaged or cracked cutting attachments by welding, straightening or modifying the shape (out of balance).

This may cause parts of the cutting attachment to come off and hit the operator or bystanders at high speed and **result in serious or fatal injuries**.

To reduce the above-mentioned risks when using a metal cutting attachment, never use a metal cutting attachment with a diameter larger than specified. It must not be too heavy. It must be manufactured from materials of adequate quality and its geometry must be correct (shape, thickness).

To reduce the risk of injury, a metal cutting attachment not manufactured by STIHL must not be heavier, thicker, have a different shape or a diameter larger than the largest metal cutting attachment approved by STIHL for this power tool model.

Vibrations

Prolonged use of the power tool may result in vibration-induced circulation problems in the hands (whitefinger disease).

No general recommendation can be given for the length of usage because it depends on several factors.

The period of usage is prolonged by:

- Hand protection (wearing warm gloves)
- Work breaks

The period of usage is shortened by:

- Any personal tendency to suffer from poor circulation (symptoms: frequently cold fingers, tingling sensations).
- Low outside temperatures.
- The force with which the handles are held (a tight grip restricts circulation).

Continual and regular users should monitor closely the condition of their hands and fingers. If any of the above symptoms appear (e.g. tingling sensation in fingers), seek medical advice.

Maintenance and Repairs

Service the machine regularly. Do not attempt any maintenance or repair work not described in the instruction manual. Have all other work performed by a servicing dealer.

STIHL recommends that you have servicing and repair work carried out exclusively by an authorized STIHL servicing dealer. STIHL dealers are regularly given the opportunity to attend training courses and are supplied with the necessary technical information.

Only use high-quality replacement parts in order to avoid the risk of accidents and damage to the machine. If you have any questions in this respect, consult a servicing dealer.

STIHL recommends the use of genuine STIHL replacement parts. They are specifically designed to match your model and meet your performance requirements.

To reduce the risk of injury, **always shut off the engine** before carrying out any maintenance or repairs or cleaning the machine. – Exception: Carburetor and idle speed adjustments.

Do not turn the engine over on the starter with the spark plug boot or spark plug removed unless the slide control /

stop switch is on **STOP** or **0** since there is otherwise a **risk of fire** from uncontained sparking.

To reduce the **risk of fire**, do not service or store your machine near open flames.

Check the fuel filler cap for leaks at regular intervals.

Use only a spark plug of the type approved by STIHL and make sure it is in good condition – see "Specifications".

Inspect the ignition lead (insulation in good condition, secure connection).

Check the condition of the muffler.

To reduce the **risk of fire and damage to hearing**, do not operate your machine if the muffler is damaged or missing.

Do not touch a hot muffler since **burn injury** will result.

Vibration behavior is influenced by the condition of the AV elements – check the AV elements at regular intervals.

Symbols on Deflectors

An **arrow** on the deflector shows the correct direction of rotation of the cutting attachments.

Some of the following symbols are applied to the outside of the deflector to indicate the approved combination of cutting attachment and deflector.



Deflector may be used with mowing heads.



Deflector must not be used with mowing heads.



Deflector may be used with grass cutting blades.



Deflector must not be used with grass cutting blades.



Deflector may be used with brush knives.



Deflector must not be used with brush knives.



Deflector must not be used with shredder blades.



Deflector must not be used with circular saw blades.

Harness / Strap

The harness is included in the scope of supply or available as a special accessory.

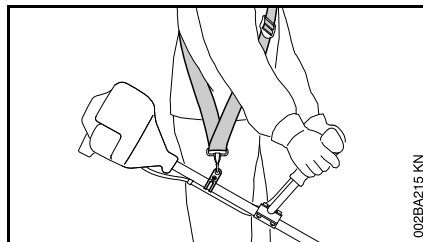

- Use a shoulder strap.
- With the engine running, attach the machine to the shoulder strap.

Grass cutting blades and brush knives must always be used in combination with a shoulder strap.

Circular saw blades must always be used in combination with a full harness with a quick-release system.

Mowing Head with Nylon Line

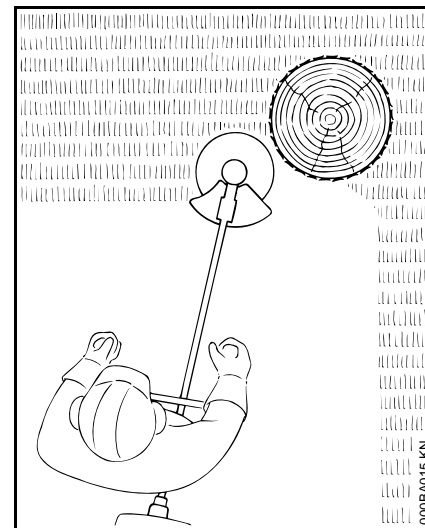

Nylon line achieves a soft cut for edging and trimming around trees, fence posts, etc. – less risk of damaging tree bark.

The mowing head comes with an instruction leaflet. Refill the mowing head with nylon line as described in the instruction leaflet.

WARNING

To reduce the risk of serious injury, never use wire or metal-reinforced line in place of the nylon line.

STIHL Polycut Mowing Head with Polymer Blades

For mowing unobstructed edges of meadows (without posts, fences, trees or similar obstacles).

Check the wear limit marks!

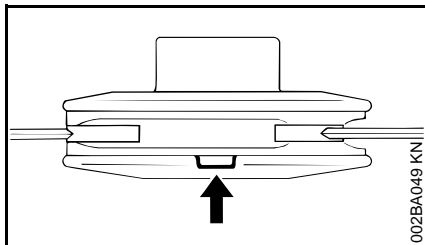

If one of the wear limit marks on the PolyCut mowing head is worn through (arrow): Do not continue using the mowing head. Install a new one. There is otherwise a **risk of injury** from thrown parts of the head.

It is important to follow the maintenance instructions for the PolyCut mowing head.

The PolyCut can also be equipped with mowing line in place of the polymer blades.

The mowing head comes with instruction leaflets. Equip the mowing head with polymers blades or nylon line as described in the instruction leaflets.

WARNING

Never use wire in place of the nylon mowing line – **risk of injury**.

Risk of Kickout (Blade Thrust) with Metal Cutting Attachments

WARNING



When using metal cutting attachments there is a risk of kickout when the rotating blade comes into contact with a solid object such as a tree trunk, branch, tree stump, rock or similar. The machine is thrown to the right or to the rear – opposite to the attachment's direction of rotation.

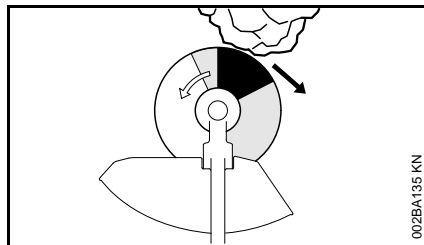

The **risk of kickout is greatest** when the **black area** of the rotating cutting attachment comes into contact with a solid object.

Grass Cutting Blade

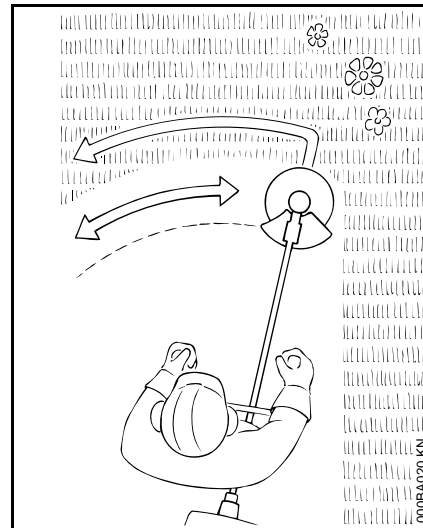

Use for grass and weeds only – sweep the brushcutter in an arc like a scythe.

WARNING

Improper use may damage the grass cutting blade – **risk of injury** from thrown parts.

Resharpener the grass cutting blade according to instructions when it has dulled noticeably.

Brush Knife

For cutting matted grass, wild growth and scrub and thinning young stands with a stem diameter of no more than 2 cm – do not cut thicker stems – **risk of accidents**.

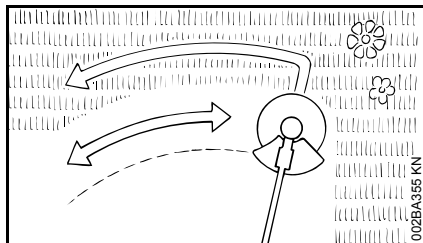

Use the brushcutter like a scythe (sweep it to the right and left) at ground level when cutting grass and thinning young stands.

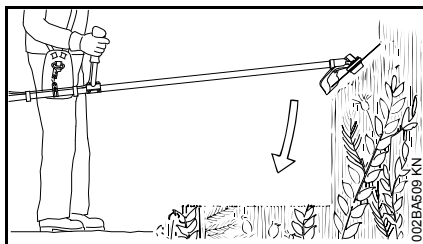

To cut wild growth and scrub, lower the brush knife down onto the growth to achieve a shredding effect – always keep the cutting attachment below hip level during this process.

Exercise extreme caution when using this method of cutting. The higher the cutting attachment is off the ground, the greater the risk of injury from cuttings being thrown sideways.

Warning! Improper use of a brush knife may cause it to crack, chip or shatter – **risk of injury** from thrown parts.

To reduce the risk of injury it is essential to take the following precautions:

- Avoid contact with stones, rocks, pieces of metal and other solid foreign objects.
- Never cut wood or shrubs with a stem diameter of more than 2 cm – use a circular saw blade for such work.
- Inspect the brush knife at regular short intervals for signs of damage. Do not continue working with a damaged brush knife.
- Resharpener the brush knife regularly and whenever it has dulled noticeably, and have it balanced if necessary (STIHL recommends a STIHL servicing dealer).

Circular Saw Blade

Suitable for cutting shrubs and trees with a maximum stem diameter of 4 cm.

Before starting the cut, accelerate the engine up to full throttle. Perform cut with uniform pressure.

Use circular saw blades only with a matching limit stop of the correct diameter.

! WARNING

To reduce the risk of blade damage, avoid contact with stones and the ground. Resharpener the blade properly in good time – dull teeth may result in the blade cracking and shattering and causing serious injury.

When felling, maintain a distance of at least two tree lengths from the next felling site.

Risk of kickout

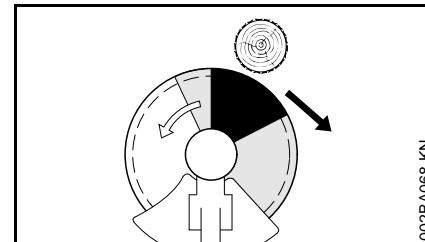











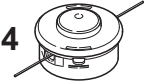

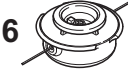
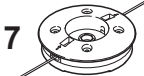

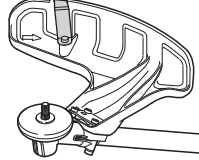
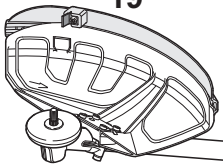
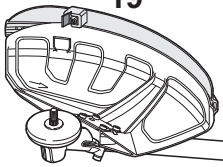



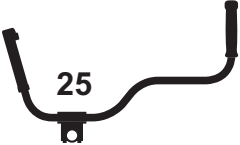

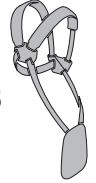





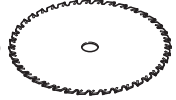

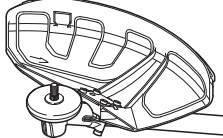
The risk of kickout is highest in the black area of the blade: Do not use this area of the circular saw blade for cutting.

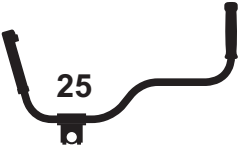
There is also a risk of kickout when using the lighter shaded areas of the blade: These areas of the blade should only be used by experienced operators with specialized training.

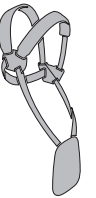
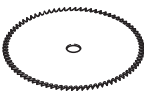
STIHL recommends that you use the non-shaded area of the circular saw blade. Always start the cut with this area of the blade.

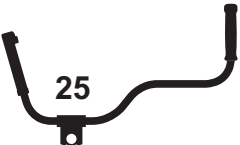
Approved Combinations of Cutting Attachment, Deflector, Handle and Harness

Cutting Attachment		Deflector, Limit Stop	Handle	Harness
<p>1 </p> <p>2 </p> <p>3 </p> <p>4 </p> <p>5 </p> <p>6 </p> <p>7 </p> <p>8 </p>	<p>17 </p> <p>18 </p> <p>19 </p>	<p>22 </p> <p>23 </p> <p>24 </p>	<p>25 </p>	<p>26 </p> <p>27 </p> <p>28 </p> <p>28 </p>
<p>9 </p> <p>10 </p> <p>11 </p> <p>12 </p> <p>13 </p> <p>14 </p>	<p>20 </p>	<p>23 </p> <p>24 </p>	<p>25 </p>	<p>27 </p> <p>28 </p>
<p>15 </p> <p>16 </p>	<p>21 </p>	<p>25 </p>	<p>29 </p>	

0000-GXX-1118-A1

Approved Combinations

Select correct combination from the table according to the cutting attachment you intend to use.

WARNING

For safety reasons only the cutting attachments, deflectors, handles and harnesses shown in each row of the table may be used together. No other combinations are permitted because of the **risk of accidents**.

Cutting Attachments

Mowing heads

- 1 STIHL SuperCut 20-2
- 2 STIHL AutoCut 25-2
- 3 STIHL AutoCut C 26-2
- 4 STIHL AutoCut 30-2
- 5 STIHL AutoCut 36-2
- 6 STIHL TrimCut 31-2
- 7 STIHL DuroCut 20-2
- 8 STIHL PolyCut 20-3

Metal cutting attachments

- 9 Grass cutting blade 230-2 (230 mm dia.)
- 10 Grass cutting blade 260-2 (260 mm dia.)
- 11 Grass cutting blade 230-4 (230 mm dia.)
- 12 Grass cutting blade 230-8 (230 mm dia.)
- 13 Grass cutting blade 250-40 Spezial (250 mm dia.)

- 14 Brush knife 250-3 (250 mm dia.)
- 15 Scratcher tooth circular saw blade 200 (200 mm dia.)
- 16 Chisel tooth circular saw blade 200-22 (4112), chisel tooth circular saw blade 200-22 HP (4001)

WARNING

Non-metal grass cutting blades, brush knives and circular saw blades are not approved.

Deflectors, Limit Stop

- 17 Deflector for mowing heads
- 18 Deflector **with** skirt and blade, for mowing heads
- 20 Deflector **without** skirt and blade, for metal cutting attachments 9 to 14
- 21 Limit stop for circular saw blades

Handle

- 22 Loop handle
- 23 Loop handle **with** barrier bar
- 24 barrier bar
- 25 Bike handle

Harnesses

- 26 Shoulder strap may be used
- 27 Shoulder strap must be used
- 28 Full harness may be used
- 29 Full harness must be used

Approved Power Tool Attachments

The following STIHL attachment may be mounted to the basic power tool:

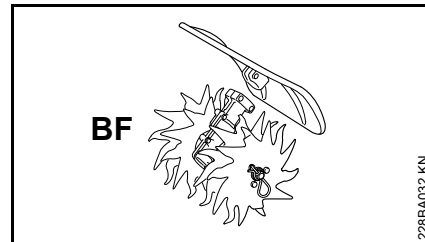

Interchangeable Attachment	Application
BF	Pick tines

Mounting the Bike Handle

Mounting the Handlebar

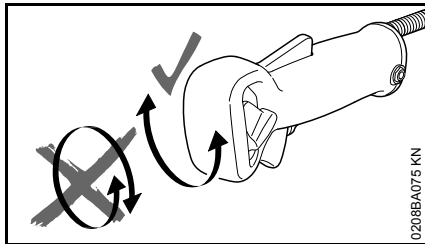

Do not rotate the control handle between unpacking and mounting it on the handlebar; see also chapter on "Adjusting the Throttle Cable".

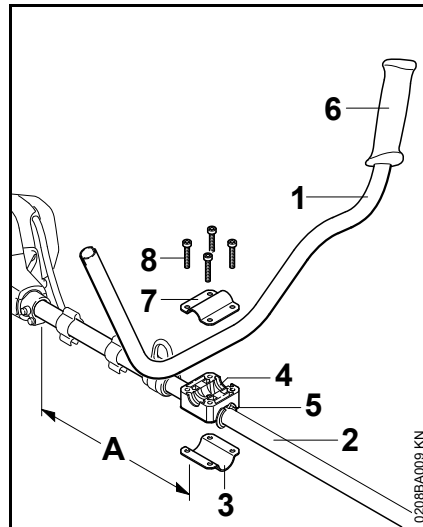

- Mount the handlebar (1) on the drive tube (2) about 40 cm (15 in) (A) forward of the engine housing.
- Position the clamp (3) and handle support (4) on the sleeve (5) on the drive tube (2).

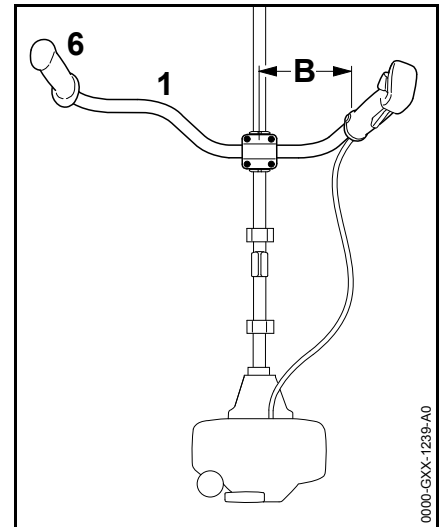

- Place the handlebar (1) in the handle support so that distance B is no more than 15 cm (6 in) – the rubber handle (6) must be on the left (viewed from engine).
- Place the clamp (7) on the handle support.
- Insert the screws (8) through the holes in the parts and screw them into the clamp (3) as far as stop.
- Line up the handlebar.
- Tighten down the screws firmly.

Mounting the Control Handle

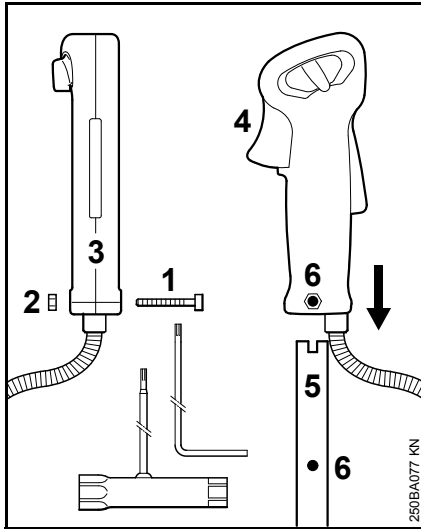

- Take out the screw (1) – the nut (2) remains in the control handle (3).
- Push the control handle onto the handlebar (5) until the holes (6) line up – the throttle trigger (4) must point towards the gearbox.
- Insert the screw (1) and tighten it down firmly.

Fitting the Throttle Cable



NOTICE

Do not kink the throttle cable or lay it in tight radii – make sure the throttle trigger moves freely.

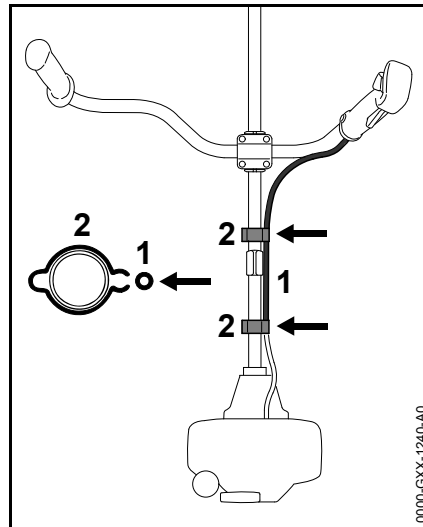

- Push the throttle cable (1) into the retainers (2).

Adjusting the Throttle Cable

- Check adjustment of throttle cable – see chapter on "Adjusting the Throttle Cable".

Mounting the Loop Handle

Mounting Loop Handle with Barrier Bar

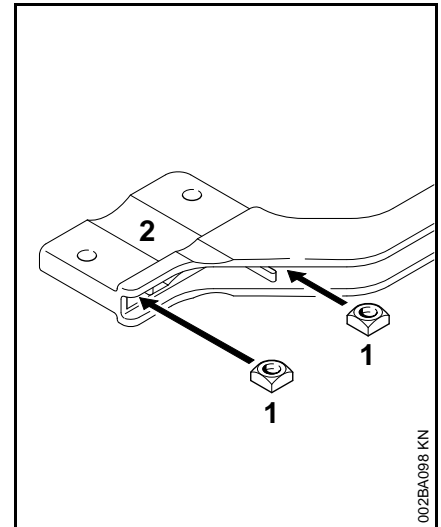

- Fit the square nuts (1) in the barrier bar (2); the holes must line up.

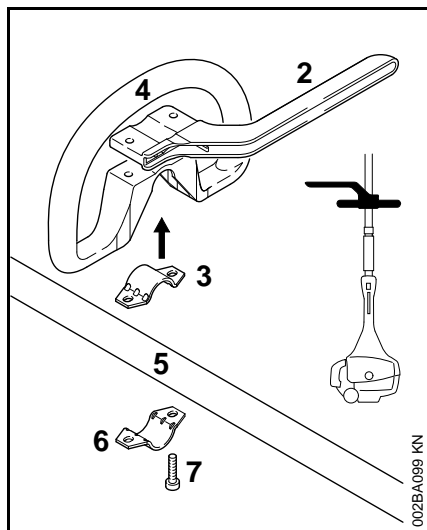

- Place the clamp (3) in the loop handle (4) and position them both against the drive tube (5).
- Position the clamp (6) against the drive tube.
- Place the barrier bar (2) in position as shown.
- Line up the holes.
- Insert the screws (7) in the holes and screw them into the barrier bar (2) as far as stop.
- Go to "Securing the Loop Handle".

Mounting the Loop Handle without Barrier Bar

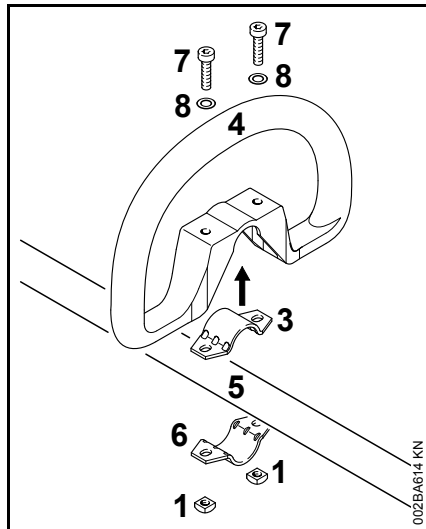

- Place the clamp (3) in the loop handle (4) and position them both against the drive tube (5).
- Position the clamp (6) against the drive tube.
- Line up the holes.
- Fit washers (8) on the screws (7) and insert the screws in the holes. Fit the square nuts (1) and screw them down as far as stop.
- Go to "Securing the Loop Handle".

Securing the Loop Handle

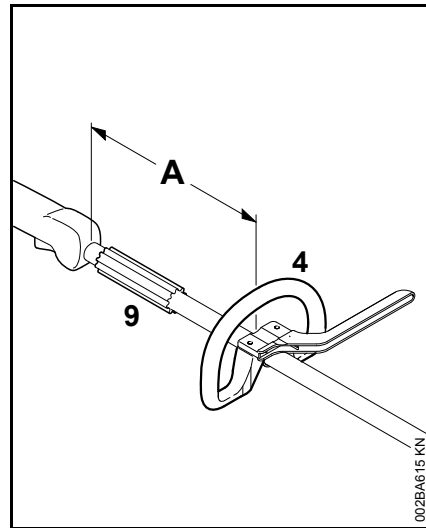

The loop handle can be adjusted to suit the height and reach of the operator and the application by changing distance (A).

Recommendation: distance (A): about 20 cm (8 in)

- Slide the handle to the required position.
- Line up the loop handle (4).
- Tighten down the screws until the loop handle can no longer be rotated on the drive tube. If no barrier bar is fitted – lock the nuts if necessary.

The sleeve (9) (not fitted on all models) must be between the loop handle and the control handle.

Adjusting the Throttle Cable

Loop Handle

A properly adjusted throttle cable is the precondition for correct operation in the starting throttle, idle and full throttle positions.

Adjust the throttle cable only when the machine is completely and properly assembled.

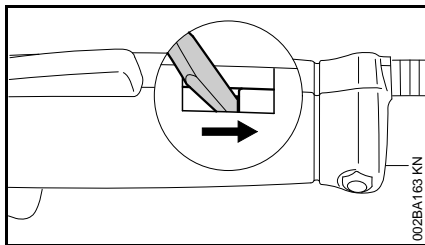

- Use a suitable tool to push the slide to the end of the slot (see illustration).

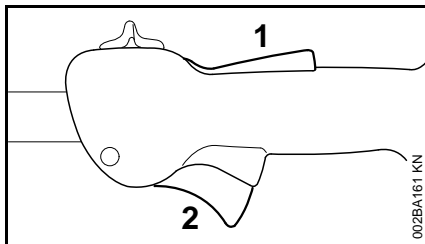

- Press down the trigger lockout (1) and squeeze the throttle trigger (2) (full throttle position) – this sets the throttle cable correctly.

Bike Handle

It may be necessary to correct the adjustment of the throttle cable after assembling the machine or after a prolonged period of operation.

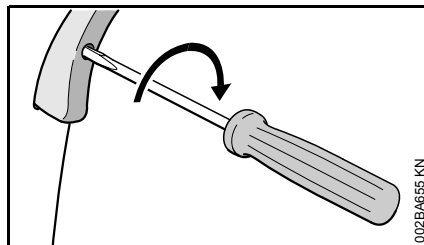

Adjust the throttle cable only when the machine is completely and properly assembled.

- Set the throttle trigger to the full throttle position.
- Carefully rotate the screw in the throttle trigger in the direction of the arrow until you feel initial resistance. Then rotate it another half turn in the same direction.

Fitting the Carrying Ring

Polymer Version

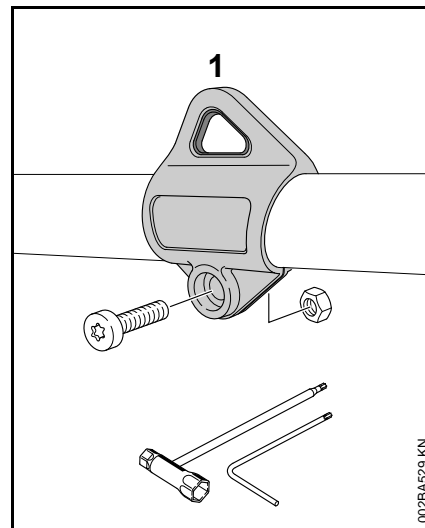

For position of carrying ring see "Main Parts".

- Push the carrying ring (1) over the drive tube.
- Insert the M5 nut in the hex recess in the carrying ring.
- Fit the M5x14 screw.
- Line up the carrying ring.
- Tighten down the screw firmly.

Mounting the deflector

Mounting the Deflector

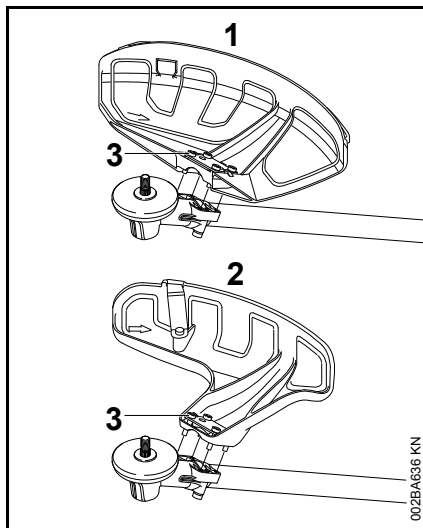

- 1 Deflector for mowing attachments
- 2 Deflector for mowing heads

Deflectors (1 and 2) are both mounted to the gearbox in the same way.

- Place the deflector on the gearbox flange.
- Insert the screws (3) and tighten them down firmly.

Fitting the Skirt and Blade

! WARNING

Risk of injury from thrown objects and contact with the cutting attachment. These parts must be fitted to the deflector (1) when you use a mowing head.

Fitting the Skirt

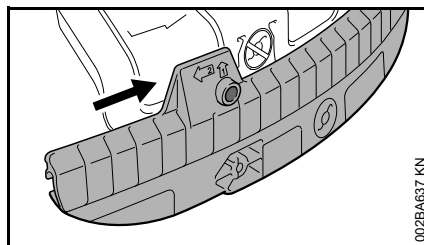

- Slide the lower guide slot of the skirt onto the deflector – it must snap into position.

Removing the Skirt

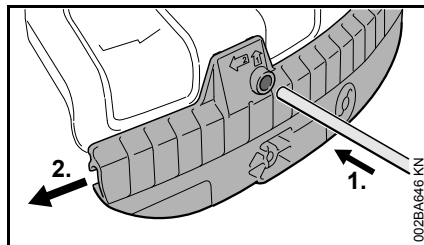

- Insert the stop pin into the hole in the skirt and use it to push the skirt to the left.
- Pull the skirt off the deflector.

Mounting the Blade

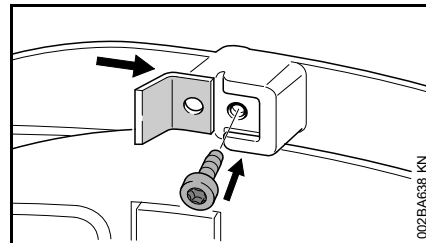

- Slide the line limiting blade into the guide on the skirt.
- Insert the screw and tighten it down firmly.

Mounting the Limit Stop

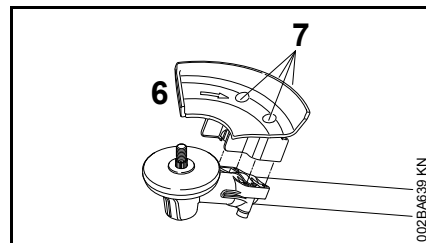

! WARNING

Risk of injury from thrown objects and contact with the cutting attachment. Always fit the limit stop (6) when you use a circular saw blade.

- Position the limit stop (6) on the gearbox flange.
- Insert the screws (7) and tighten them down firmly.

Mounting the Cutting Attachment

Placing power tool on the ground

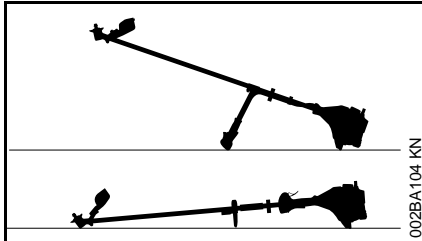

- Shut off the engine.
- Lay your power tool on its back so that the cutting attachment mounting face is pointing up.

Mounting Hardware for Cutting Attachments

The mounting hardware supplied depends on the cutting attachment that comes as original equipment with the new machine.

Machine supplied with mounting hardware

Mowing heads and metal cutting attachments may be mounted.

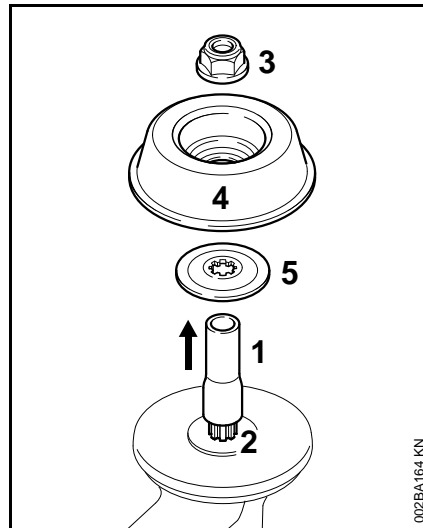

Depending on the cutting attachment, it may be necessary to use the nut (3), rider plate (4) and thrust washer (5).

These parts are included in a kit supplied with the machine and are also available as special accessories.

Removing the transport lock

- Pull the hose (1) off the shaft (2).

Machine supplied without mounting hardware

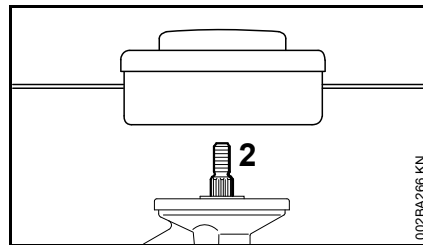

Only mowing heads may be used which mount directly to the shaft (2).

Blocking the Shaft

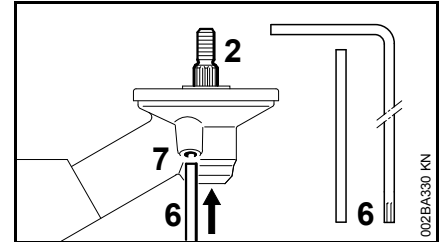

The output shaft (2) must be blocked with the stop pin (6) or screwdriver (6) to mount or remove cutting tools. These parts come standard with the machine or are available as special accessories.

- Insert the stop pin (6) or screwdriver (6) in the hole (7) in the gearbox as far as stop – and apply slight pressure.
- Rotate shaft, nut or cutting attachment until the stop pin slips into position and blocks the shaft.

Removing the Mounting Hardware

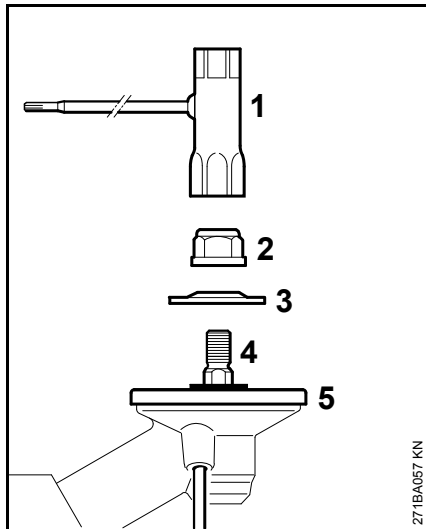

- Block the shaft.
- Use the combination wrench (1) to loosen and remove the nut (2) **clockwise** (left-hand thread).
- Take the thrust washer (3) off the shaft (4). **Do not** remove the thrust plate (5).

Mounting the Cutting Attachment



WARNING

Use a deflector that matches the cutting attachment – see "Mounting the Deflector".

Fitting Mowing Head with Screw Mounting

Keep the instruction leaflet for the mowing head in a safe place.

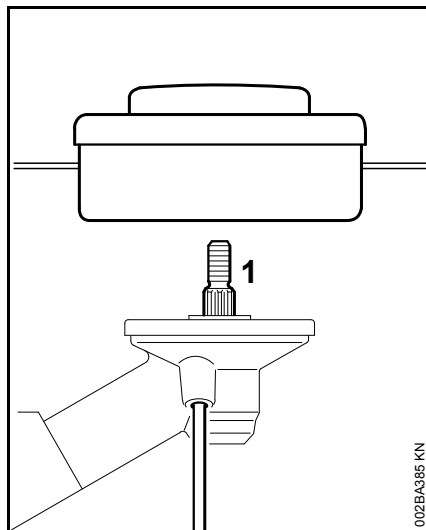

- Screw the mowing head counterclockwise on to the shaft (1) as far as stop.
- Block the shaft.
- Tighten down the mowing head firmly.



NOTICE

Remove the tool used to block the shaft.

Removing the Mowing Head

- Block the shaft.
- Unscrew the mowing head clockwise.

Mounting Metal Cutting Attachments

Keep the leaflet and packaging of the metal cutting attachment in a safe place.



WARNING

Wear protective gloves to reduce the risk of direct contact with the sharp cutting edges.

Mount only one metal cutting attachment.

Check direction of rotation of cutting attachment

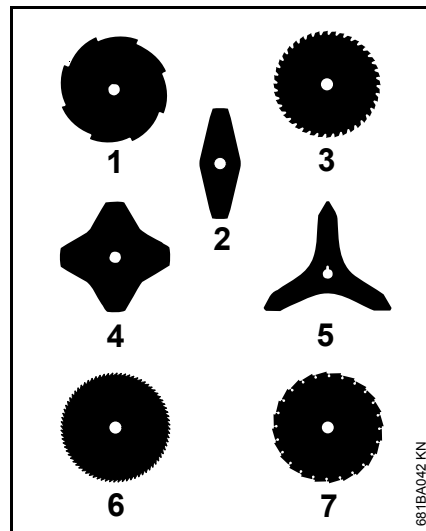

Cutting attachments 2, 4 and 5 may be mounted either way round – they must be turned over regularly to help avoid one-sided wear.

The cutting edges of cutting attachments 1, 3, 6 and 7 must point clockwise.

! WARNING

Direction of rotation is indicated by an arrow on the inside of the deflector.

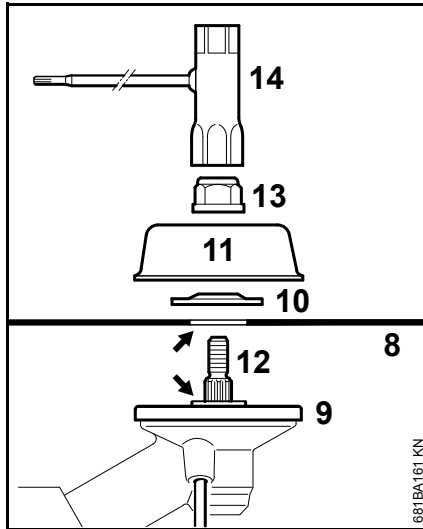

- Place the cutting attachment (8) on the thrust plate (9).

! WARNING

Collar (see arrow) must engage the cutting attachment's mounting hole.

Securing the cutting attachment

- Fit the thrust washer (10) – convex side must face up.
- Fit the rider plate (11).
- Block the shaft (12).
- Use the combination wrench (14) to screw the mounting nut (13) on to the output shaft counterclockwise and tighten it down firmly.

! WARNING

If the mounting nut has become too loose, fit a new one.

⚙ NOTICE

Remove the tool used to block the shaft.

Removing the Metal Cutting Attachment

! WARNING

Wear protective gloves to reduce the risk of direct contact with the sharp cutting edges.

- Block the shaft.
- Unscrew the mounting nut clockwise.
- Remove cutting attachment and its mounting hardware from the gearbox – but **do not** remove the thrust plate (9).

Fuel

Your engine requires a mixture of gasoline and engine oil.

! WARNING

For health reasons, avoid direct skin contact with gasoline and avoid inhaling gasoline vapor.

STIHL MotoMix

STIHL recommends the use of STIHL MotoMix. This ready-to-use fuel mix contains no benzol or lead, has a high octane rating and ensures that you always use the right mix ratio.

STIHL MotoMix uses STIHL HP Ultra two-stroke engine oil for an extra long engine life.

MotoMix is not available in all markets.

Mixing Fuel

⚙ NOTICE

Unsuitable fuels or lubricants or mix ratios other than those specified may result in serious damage to the engine. Poor quality gasoline or engine oil may damage the engine, sealing rings, hoses and the fuel tank.

Gasoline

Use only high-quality **brand-name** gasoline with a minimum octane rating of 90 – leaded or unleaded.

Gasoline with an ethanol content of more than 10% can cause running problems in engines with a manually adjustable carburetor and should not be used in such engines.

Engines equipped with M-Tronic deliver full power when run on gasoline with an ethanol content of up to 25% (E25).

Engine Oil

If you mix the fuel yourself, use only STIHL two-stroke engine oil or another high-performance engine oil in accordance with JASO FB, JASO FC, JASO FD, ISO-L-EGB, ISO-L-EGC or ISO-L-EGD.

STIHL specifies STIHL HP Ultra two-stroke engine oil or an equivalent high-performance engine oil in order to maintain emission limits over the machine's service life.

Mix Ratio

STIHL 50:1 two-stroke engine oil: 50 parts gasoline to 1 part oil

Examples

Gasoline Liters	STIHL engine oil 50:1 Liters (ml)
1	0.02 (20)
5	0.10 (100)
10	0.20 (200)
15	0.30 (300)
20	0.40 (400)
25	0.50 (500)

- Use a canister approved for storing fuel. Pour oil into canister first, then add gasoline and mix thoroughly.

Storing Fuel

Store fuel only in approved safety-type fuel canisters in a dry, cool and safe location protected from light and the sun.

Fuel mix ages – only mix sufficient fuel for a few weeks work. Do not store fuel mix for longer than 30 days. Exposure to light, the sun, low or high temperatures can quickly make the fuel mix unusable.

STIHL MotoMix may be stored for up to 2 years without any problems.

- Thoroughly shake the mixture in the canister before fueling your machine.

WARNING

Pressure may build up in the canister – open it carefully.

- Clean the fuel tank and canister from time to time.

Dispose of remaining fuel and cleaning fluid properly in accordance with local regulations and environmental requirements.

Fueling



Preparations

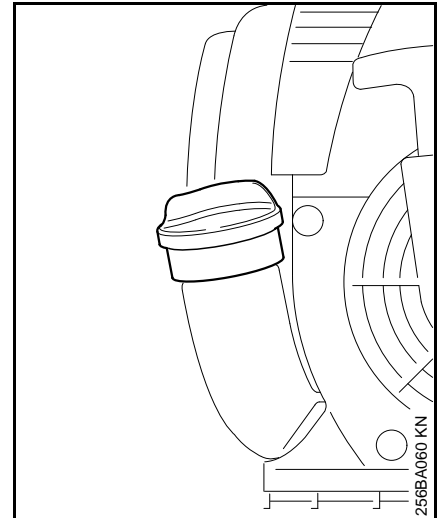

- Before fueling, clean the filler cap and the area around it to ensure that no dirt falls into the tank.
- Position the machine so that the tank cap faces up.

Filling Up with Fuel

Take care not to spill fuel while fueling and do not overfill the tank. STIHL recommends you use the STIHL filler nozzle for fuel (special accessory).

- Open the tank cap.
- Fill up with fuel.
- Closing the Tank Cap

WARNING

After fueling, tighten down the filler cap as securely as possible by hand.

Fitting the Harness

The type and style of the harness/shoulder strap depend on the market.

The use of the shoulder strap is described in the chapter on "Approved Combinations of Cutting Attachment, Deflector, Handle and Harness".

Shoulder Strap

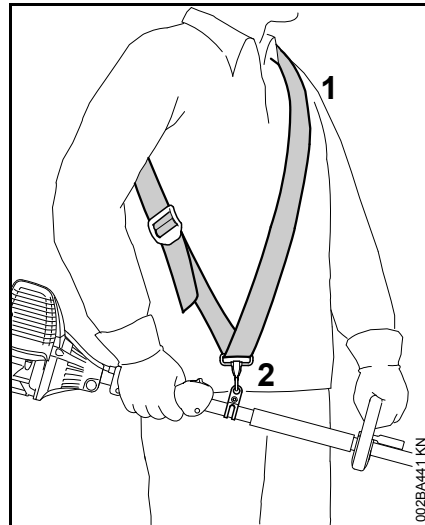

- Put on the shoulder strap (1).
- Adjust the length of the strap so that the carabiner (2) is about a hand's width below your right hip.
- Balance the machine – see "Balancing the Machine".

Full Harness

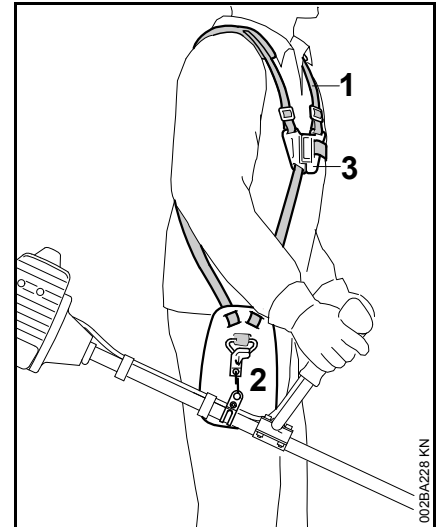

- Put on the harness (1) and close the locking plate (3).
- Adjust the length of the strap – with the machine attached, the carabiner (2) must be about a hand's width below your right hip.
- Balance the machine – see "Balancing the Machine".

Attaching Machine to Harness

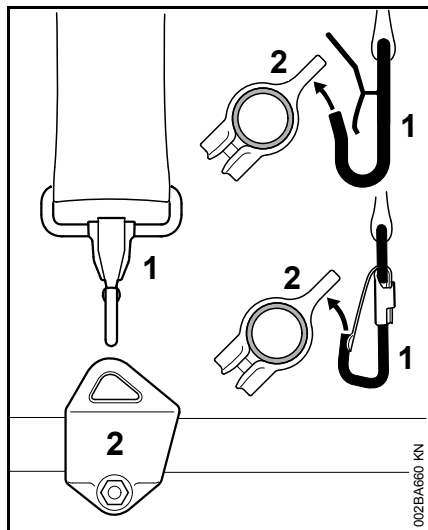

The type and style of the harness and carabiner (spring hook) depend on the market.

- Attach the carabiner (1) to the carrying ring (2) on the drive tube.

Disconnecting Machine from Harness

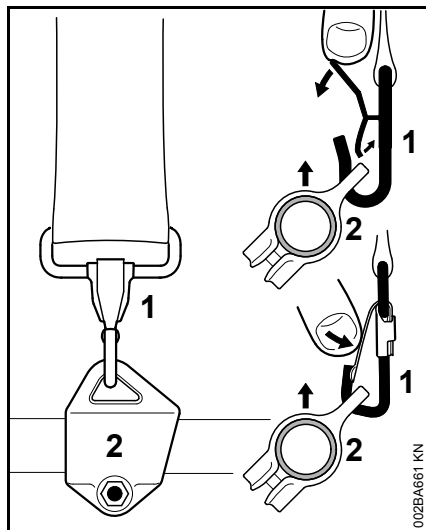

- Press down the bar on the carabiner (1) and pull the carrying ring (2) out of the carabiner.

Throwing Off the Machine

! WARNING

The machine must be quickly thrown off in the event of imminent danger. Practice removing and putting down the machine as you would in an emergency. To avoid damage, do not throw the unit to the ground when practicing.

Practice quickly detaching the power tool from the carabiner as described under "Disconnecting Machine from Harness".

If you are using a shoulder strap: Practice slipping the strap off your shoulder.

If you are using a full harness: Practice quickly opening the locking plate and slipping the harness straps off your shoulders.

Balancing the Machine

Balancing the Machine

The unit is balanced differently depending on the cutting attachment used.

Proceed as follows until the conditions specified under "Floating positions" have been met:

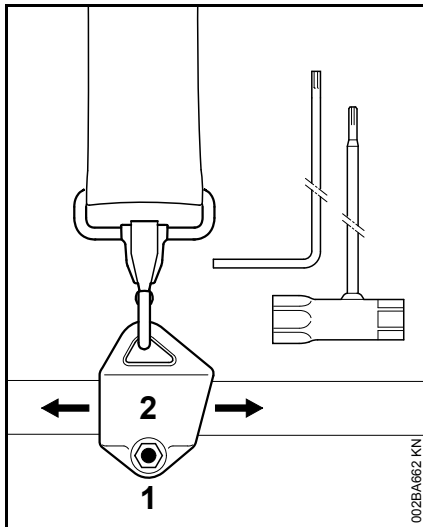

- Loosen the screw (1).
- Slide the carrying ring (2) along the drive tube.
- Tighten the screw moderately.
- Allow the unit to hang freely.
- Check the position obtained.

Balanced positions

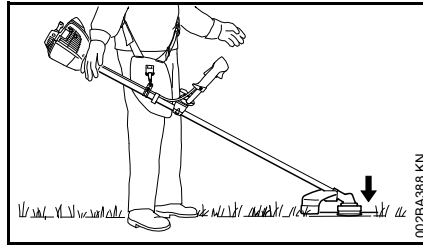

Mowing tools such as mowing heads, grass cutting blades and brush knives

- should just touch the ground.

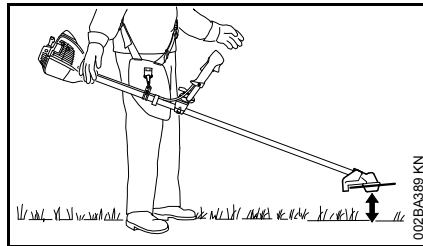

Circular saw blades

- should "hover" about 20 cm (8 in) above the ground.

When the correct floating position has been reached:

- Tighten down the screw on the carrying ring firmly.

Starting / Stopping the Engine

Controls

Control handle on handlebar

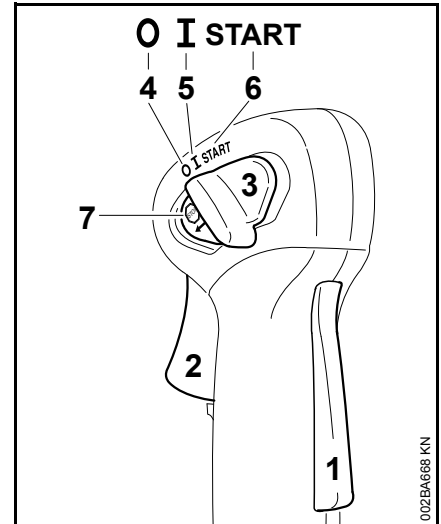

- 1 Throttle trigger lockout
- 2 Throttle trigger
- 3 Slide control

Control handle on drive tube

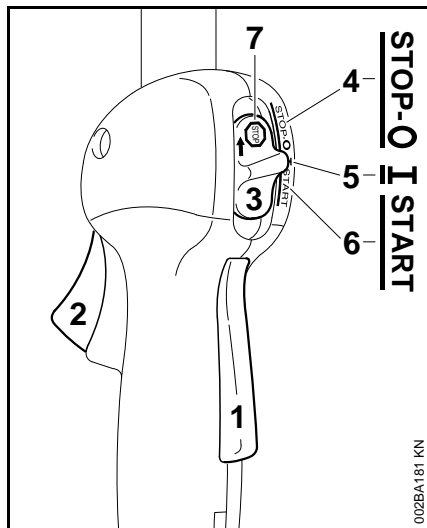



- 1 Throttle trigger lockout
- 2 Throttle trigger
- 3 Slide control

Positions of slide control

- 4 **STOP-0** – engine off – ignition is switched off
- 5 **I** – normal run position – the engine is running or can start
- 6 **START** – ignition is switched on – the engine can start



Symbol on slide control

- 7  – stop symbol and arrow. To stop the engine, push the slide control in the direction of the arrow on the stop symbol () to **STOP-0**.

Starting

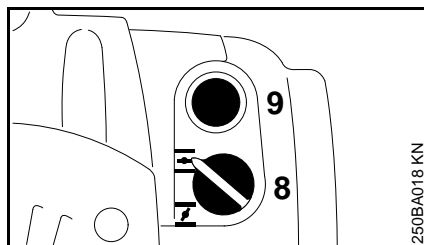
- Press down the trigger lockout lever and squeeze the throttle trigger
- and hold them in that position.
- Move the slide control to **START** and hold it there.
- Now release the throttle trigger, slide control and trigger lockout lever in that order. This is the **starting throttle position**.



- Set the choke knob (8) to:
 -  if the engine is cold
 -  for warm start – also use this position if the engine has been running but is still cold.
- Press the manual fuel pump bulb (9) at least five times – even if the bulb is filled with fuel.

Cranking

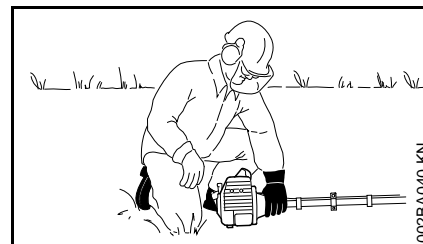
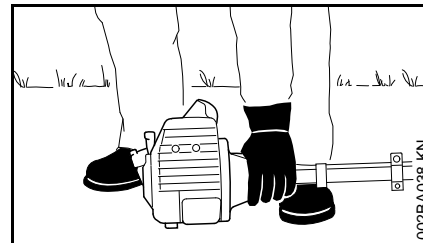

- Place the unit on the ground: It must rest securely on the engine support and the deflector.
- If fitted: Remove the transport guard from the cutting attachment.

To reduce the risk of accidents, check that the cutting attachment is not touching the ground of any other obstacles.

- Make sure you have a firm footing, either standing, stooping or kneeling.
- Hold the unit **firmly** on the ground with your left hand and press down – do not touch the throttle trigger, lockout lever or slide control.



Do not stand or kneel on the drive tube.

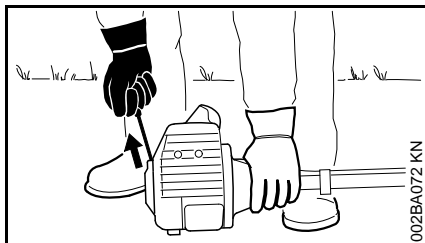

- Hold the starter grip with your right hand.
- Pull the starter grip slowly until you feel it engage and then give it a brisk strong pull.

NOTICE

Do not pull out the starter rope all the way – **it might otherwise break.**

- Do not let the starter grip snap back. Guide it slowly back into the housing so that the starter rope can rewind properly.
- Continue cranking.

When engine begins to fire

- Turn the choke knob to .
- Continue cranking until the engine runs.

As soon as the engine runs

- Blip the throttle trigger **immediately**. The slide control moves to the normal run position **I** – and the engine settles down to idle speed.

WARNING

Make sure the carburetor is correctly adjusted. The cutting attachment must not rotate when the engine is idling.

Your machine is now ready for operation.

Stopping the Engine

- Push the slide control in the direction of the arrow on the stop symbol () to **STOP-0**.

At very low outside temperatures

As soon as the engine runs:

- Blip the throttle trigger to disengage the **starting throttle position**. The slide control moves to the normal run position **I** – and the engine settles down to idle speed.
- Open the throttle slightly.
- Warm up the engine for a short period.



If the engine does not start

Choke knob

If you did not turn the choke knob to  quickly enough after the engine began to fire, the combustion chamber is flooded.

- Turn the choke knob to .
- Select the **starting throttle position**.
- Start the engine by pulling the starter rope briskly – 10 to 20 pulls may be necessary.

If the engine still does not start

- Push the slide control in the direction of the arrow on the stop symbol () to **STOP-0**.
- Remove the spark plug – see "Spark Plug".
- Dry the spark plug.
- Open the throttle wide.
- Crank the engine several times with the starter to clear the combustion chamber.
- Refit the spark plug – see "Spark Plug".
- Move the slide control to **START**.
- Set the choke knob to  – even if the engine is cold.
- Start the engine.

Throttle Cable Adjustment

- Check adjustment of throttle cable – see chapter on "Adjusting the Throttle Cable".

Fuel tank run until completely dry

Recommendation: Carry out the following steps irrespective of the engine's operating condition before the tank was run dry.

- After refueling, press the manual fuel pump bulb at least five times – even if the bulb is filled with fuel.
- Turn the choke knob to .
- Go to section on "Starting" and re-start the engine as described for a cold engine.

Transporting the Unit

Using Transport Guard

The type of transport guard depends on the metal cutting attachment supplied with the machine. Transport guards are available as special accessories.

230 mm Grass Cutting Blades

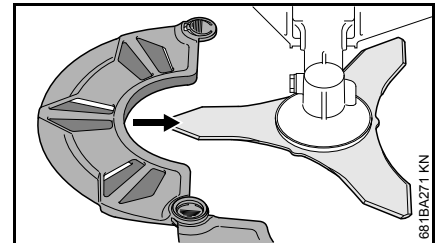
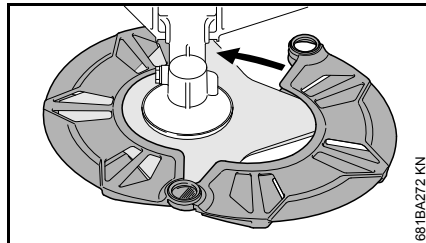
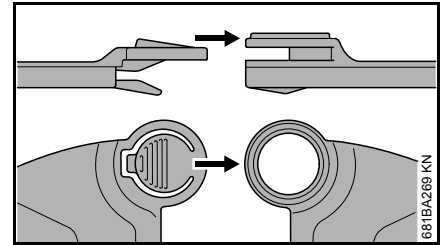
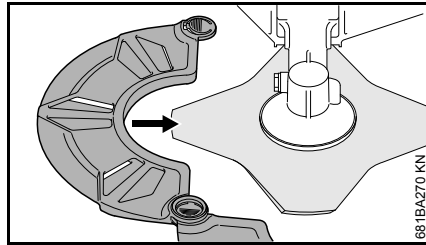
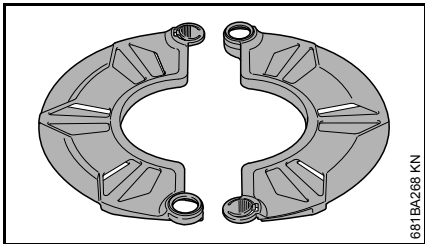

250 mm Brush Knives

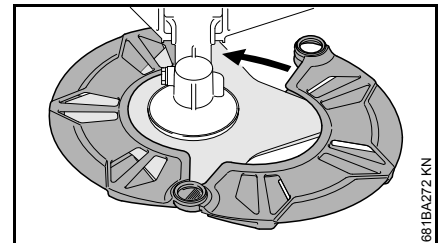
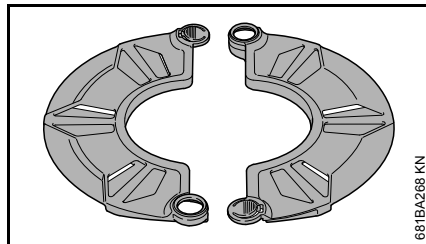
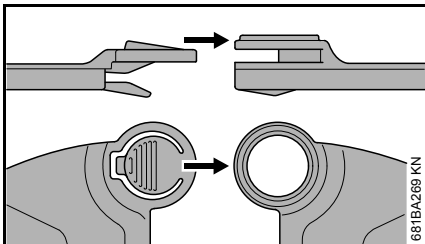

Grass Cutting Blades up to 260 mm

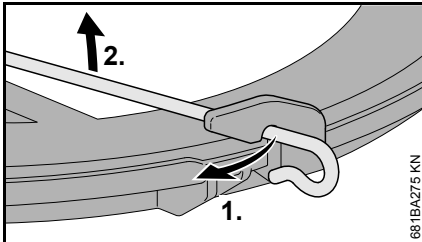
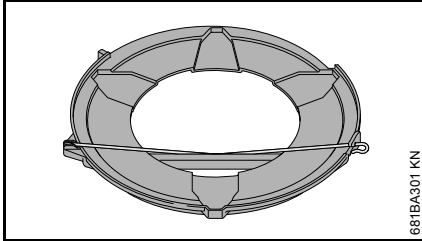

- Disconnect wire rod from the transport guard.
- Swing wire rod outwards.

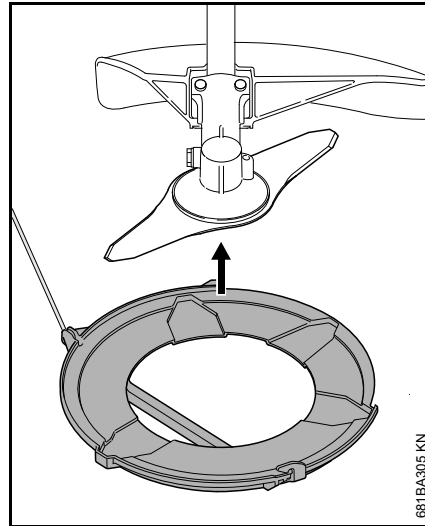

- Fit the transport guard on the cutting attachment from below.

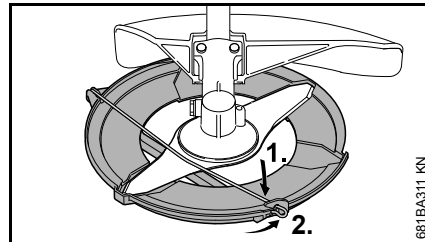

- Swing wire rod into position.
- Hook wire rod to the transport guard.

Circular Saw Blades

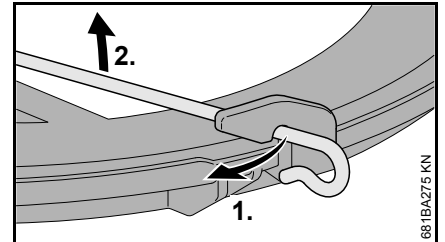
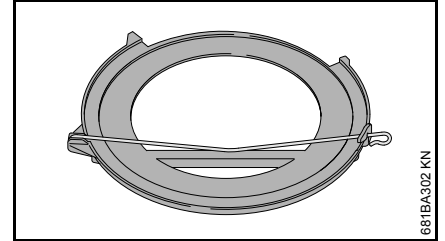

- Disconnect wire rod from the transport guard.

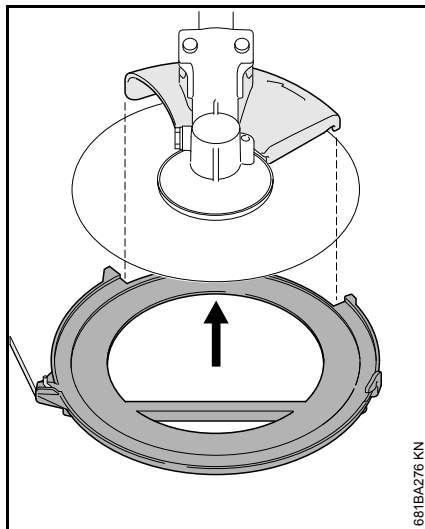

661BA276 KN

- Swing wire rod outwards.
- Fit transport guard on saw blade from below, making sure the limit stop is properly seated in the recess.

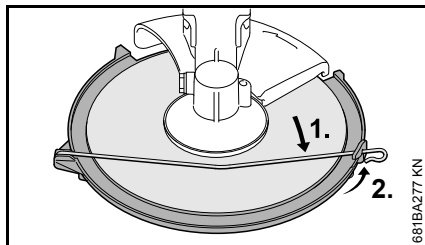

661BA277 KN

- Swing wire rod into position.
- Hook wire rod to the transport guard.

Operating Instructions

During break-in period

A factory-new machine should not be run at high revs (full throttle off load) for the first three tank fillings. This avoids unnecessary high loads during the break-in period. As all moving parts have to bed in during the break-in period, the frictional resistances in the engine are greater during this period. The engine develops its maximum power after about 5 to 15 tank fillings.

During Operation

After a long period of full throttle operation, allow the engine to run for a short while at idle speed so that engine heat can be dissipated by the flow of cooling air. This protects engine-mounted components (ignition, carburetor) from thermal overload.

After Finishing Work

Storing for a short period: Wait for the engine to cool down. Empty the fuel tank and keep the machine in a dry place, well away from sources of ignition, until you need it again. For longer out-of-service periods – see "Storing the Machine".

Air filter

If there is a noticeable loss of engine power

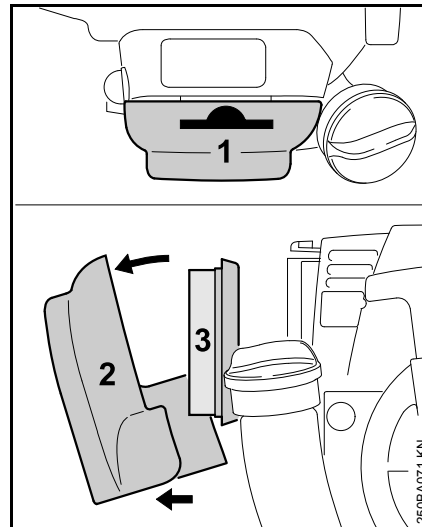

250BA071 KN

- Turn the choke knob to \bar{I} .
- Press in the tab (1) and remove the filter cover (2).
- Clean away loose dirt from around the filter (3) and inside the filter cover.
- Remove and check the filter element – replace it if is dirty or damaged.
- Install the filter element in the filter cover.
- Refit the filter cover.

Adjusting the Carburetor

General Information

The carburetor comes from the factory with a standard setting.

This setting provides an optimum fuel-air mixture under most operating conditions.

Preparations

- Shut off the engine.
- Mount the cutting attachment.
- Check the air filter and clean or replace if necessary.
- Check that the throttle cable is properly adjusted – readjust if necessary – see chapter on "Adjusting the Throttle Cable".

Standard Setting

- High speed screw (H) = 1 1/2
- Low speed screw (L) = 1

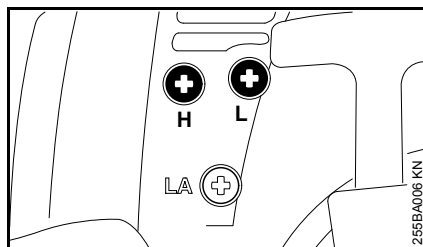

- Turn the high speed screw (H) carefully clockwise until it is against its seat, then turn it back 2 full turns.
- Turn the low speed screw (L) carefully clockwise as far as stop, then turn it back 1 turn

Adjusting Idle Speed

- Carry out standard setting.
- Start and warm up the engine.

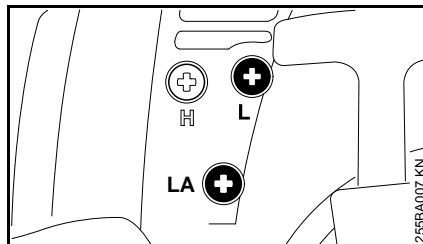

Engine stops while idling

- Turn the idle speed screw (LA) clockwise until the engine runs smoothly – the cutting attachment must not rotate.

Cutting attachment rotates when engine is idling

- Turn the idle speed screw (LA) counterclockwise until the cutting attachment stops moving and then turn the screw another 1/2 to 1 full turn in the same direction.

! WARNING

If the cutting attachment continues to rotate when the engine is idling, have your machine checked and repaired by your servicing dealer.

Erratic idling behavior, poor acceleration (even though setting of LA screw is correct).

Idle setting is too lean

- Turn the low speed screw (L) counterclockwise, no more than 1/2 turn, until the engine runs and accelerates smoothly.

Erratic idling behavior

Idle setting is too rich

- Turn the low speed screw (L) clockwise, no more than 1/2 turn, until the engine runs and accelerates smoothly.

It is usually necessary to change the setting of the idle speed screw (LA) after every correction to the low speed screw (L).

Fine Tuning for Operation at High Altitude

A slight correction of the setting may be necessary if the engine does not run satisfactorily:

- Carry out standard setting.
- Warm up the engine.
- Turn high speed screw (H) slightly clockwise (leaner) – no more than a 3/4 turn.

 **NOTICE**

After returning from high altitude, reset the carburetor to the standard setting.

If the setting is too lean there is a risk of engine damage due to insufficient lubrication and overheating.

Spark Plug

- If the engine is down on power, difficult to start or runs poorly at idle speed, first check the spark plug.
- Fit a new spark plug after about 100 operating hours – or sooner if the electrodes are badly eroded. Install only suppressed spark plugs of the type approved by STIHL – see "Specifications".

Removing the Spark Plug

- Turn off the engine.

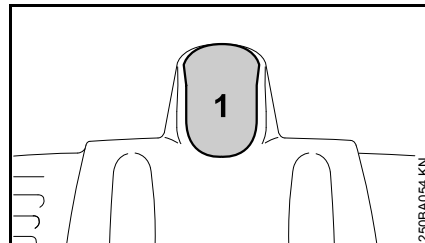

- Pull off the spark plug boot (1).
- Unscrew the spark plug.

Checking the Spark Plug

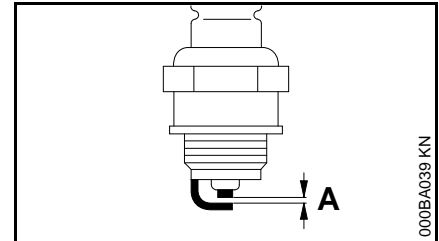

- Clean dirty spark plug.
- Check electrode gap (A) and readjust if necessary – see "Specifications".
- Rectify the problems which have caused fouling of the spark plug.

Possible causes are:

- Too much oil in fuel mix.
- Dirty air filter.
- Unfavorable running conditions.

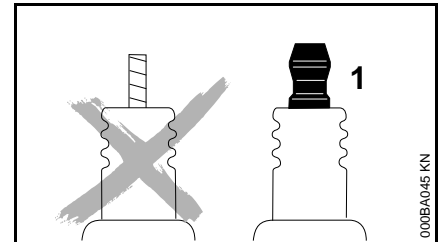

 **WARNING**

Arcing may occur if the adapter nut (1) is loose or missing. Working in an easily combustible or explosive atmosphere may cause a fire or an explosion. This can result in serious injuries or damage to property.

- Use resistor type spark plugs with a properly tightened adapter nut.

Installing the Spark Plug

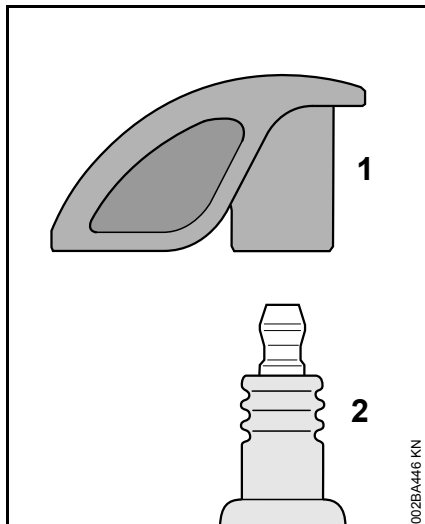

- Screw the spark plug (2) into the cylinder and fit the boot (1) (press it down firmly).

Engine Running Behavior

If engine running behavior is unsatisfactory even though the air filter is clean and the carburetor and throttle cable are properly adjusted, the cause may be the muffler.

Have the muffler checked by a servicing dealer for contamination (carbonization).

STIHL recommends that you have servicing and repair work carried out exclusively by an authorized STIHL servicing dealer.

Lubricating the Gearbox

Gearbox without Screw Plug

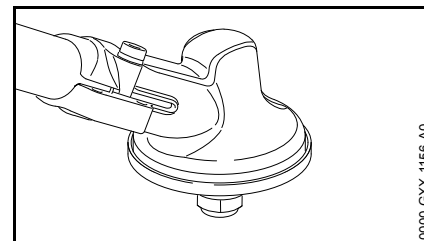

- If the gearbox has no screw plug: gearbox is maintenance-free and requires no re-lubrication.

Gearbox with Screw Plug

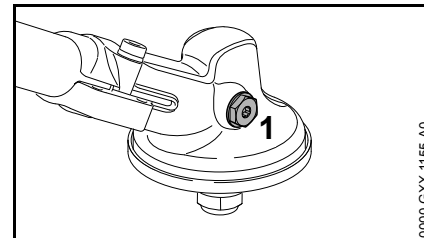

- If the gearbox has a screw plug (1): Check grease level after every 25 hours of operation and re-lubricate if necessary.

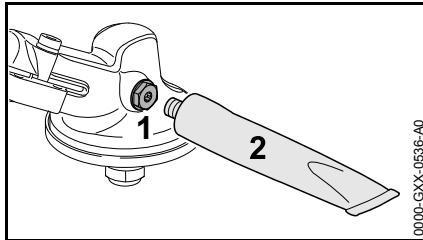

- Remove the screw plug (1).
- If no grease can be seen on the inside of the screw plug (1): Screw the tube (2) of STIHL gear lubricant (special accessory) into the filler hole.
- Squeeze no more than 5 g (1/5 oz) grease into the gearbox.



NOTICE

Do not completely fill the gearbox with grease.

- Unscrew the tube (2).
- Insert the screw plug (1) and tighten it down firmly.

Replacing the Starter Rope and Rewind Spring

Removing the Fan Housing

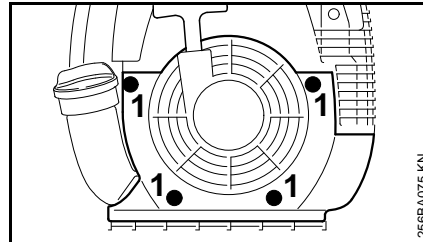

- Take out the screws (1).
- Remove the fan housing.

Replacing the Starter Rope

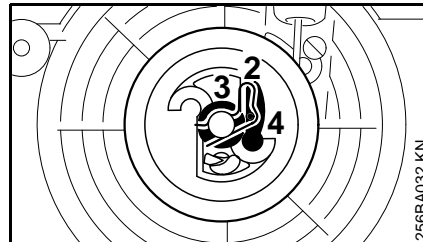

- Remove the spring clip (2).
- Carefully remove the rope rotor with washer (3) and pawl (4).

WARNING

The rewind spring may pop out and uncoil during this operation – **take care to avoid the risk of injury.**

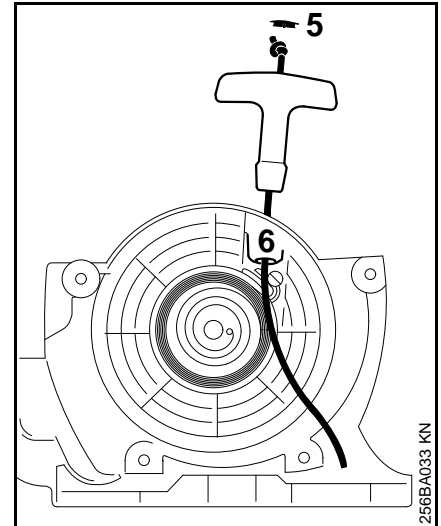

- Pry the cap (5) out of the grip.
- Remove the remaining rope from the rotor and starter grip.
- Tie a simple overhand knot in the new rope and then thread it through the top of the grip and the rope bushing (6).
- Refit the cap in the grip.

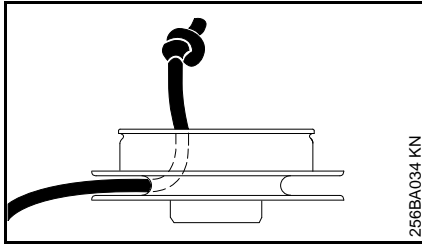

- Thread the rope through the rotor and secure it with a simple overhand knot.
- Coat the rope rotor bearing bore with non-resinous oil.
- Slip the rotor over the starter post – turn it back and forth to engage the anchor loop of the rewind spring.

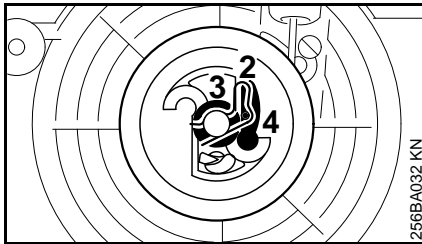

- Fit the pawl (4).
- Fit the washer (3).
- Push the spring clip (2) into position – it must point counterclockwise as shown and engage the pawl's peg.

Tension the rewind spring.

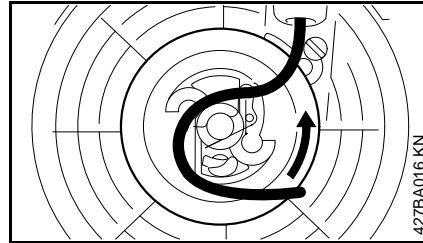

- Make a loop in the unwound starter rope and use it to turn the rope rotor six full revolutions counterclockwise.
- Hold the rope rotor steady.
- Pull out and straighten the twisted rope.
- Release the rope rotor.
- Slowly release the starter rope so that it winds onto the rotor.

The starter grip must sit firmly in the rope bushing. If the grip droops to one side: Add one more turn on the rope rotor to increase spring tension.

NOTICE

When the starter rope is fully extended it must still be possible to rotate the rotor another one and a half turns. If this is not the case, the spring is overtensioned **and could break.**

- Take one turn of the rope off the rotor.
- Install the fan housing.

Replacing a Broken Rewind Spring

- Remove the rope rotor as described in "Replacing the Starter Rope".

WARNING

The bits of the spring may still be under tension and could fly apart when you remove the rope rotor and spring housing. **To reduce the risk of injury, Wear a face shield and work gloves.**

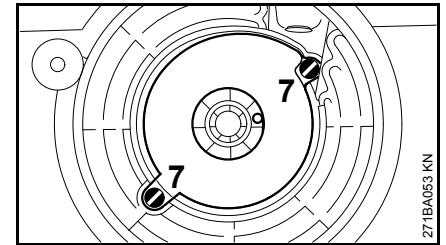

- Take out the screws (7).
- Remove the spring housing and pieces of spring.
- Lubricate the new, ready-to-fit replacement spring in the new spring housing with a few drops of resin-free oil.
- Place the replacement spring with spring housing in position – bottom plate facing up.

If the spring pops out and uncoils, refit it in the clockwise direction, starting outside and working inwards.

- Fit the screws.
- Refit the rope rotor as described in "Replacing the Starter Rope".
- Tension the rewind spring.
- Install the fan housing.

Storing the Machine

For periods of 3 months or longer

- Drain and clean the fuel tank in a well ventilated area.
- Dispose of fuel properly in accordance with local environmental requirements.
- Run the engine until the carburetor is dry – this helps prevent the carburetor diaphragms sticking together.
- Remove, clean and inspect the cutting attachment. Coat metal cutting attachments with corrosion inhibitor.
- Thoroughly clean the machine.
- Clean the air filter.
- Store the machine in a dry and secure location – out of the reach of children and other unauthorized persons.

Sharpening Metal Cutting Blades

- Use a sharpening file (see "Special Accessories") to sharpen dull cutting attachments. In case of more serious wear or nicks: Resharpener with a grinder or have the work done by a dealer – STIHL recommends a STIHL servicing dealer.
- Sharpen frequently, take away as little metal as possible – two or three strokes of the file are usually enough.

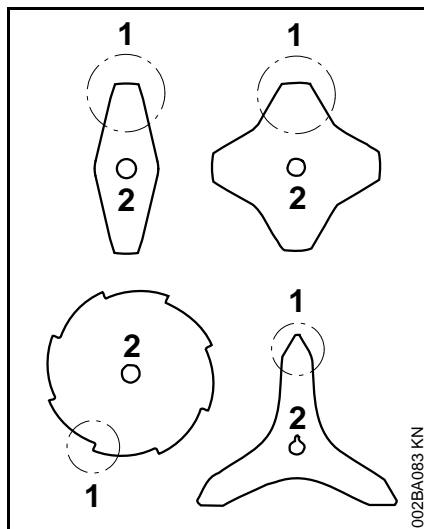

- Resharpener the teeth (1) uniformly – do not alter the contour of the parent blade (2) in any way.

See cutting attachment packaging for additional sharpening instructions. Keep the packaging for future reference.

Balancing

- After resharpening about 5 times, check the cutting attachment for out-of-balance on a STIHL balancer – see "Special Accessories" – or have it checked by a dealer and re-balanced as necessary – STIHL recommends a STIHL servicing dealer.

Maintaining the Mowing Head

Placing power tool on the ground

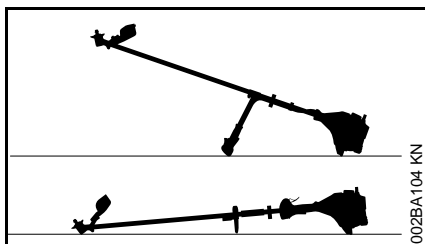

- Shut off the engine.
- Lay your power tool on its back so that the cutting attachment mounting face is pointing up.

Replacing Nylon Line

Always check the mowing head for signs of wear before replacing the nylon line.

! WARNING

If there are signs of serious wear, replace the complete mowing head.

The nylon mowing line is referred to as "nylon line" or "line" in the following.

The mowing head is supplied with illustrated instructions for replacing the nylon line. Keep the instructions for the mowing head in a safe place.

- If necessary, remove the mowing head.

Adjusting Nylon Line

STIHL SuperCut

Fresh line is advanced automatically if the remaining line is **at least 6 cm (2 1/2 in)** long. The blade on the deflector trims overlong lines to the correct length.

STIHL AutoCut

- With the engine running, hold the rotating mowing head above the grass surface.
- Tap it on the ground once – fresh line is advanced and the blade on the deflector trims it to the right length.

Fresh line is advanced every time the mowing head is tapped on the ground. For this reason observe the mowing head's cutting performance during operation. If the mowing head is tapped on the ground too often, the line limiting blade will unnecessarily cut off unused lengths of nylon line.

Line feed operates only if both lines are still at least **2.5 cm (1 in)** long.

STIHL TrimCut

! WARNING

To reduce the risk of injury, always shut off the engine before adjusting the nylon line by hand.

- Pull the spool up – rotate it about 1/6 turn counterclockwise until it engages – and allow it to spring back.
- Pull ends of the lines outward.

Repeat the above procedure as necessary until both lines reach the limiter blade on the deflector.

Rotating the spool from one stop to the next advances about **4 cm (1 1/2 in)** of fresh line.

Replacing Nylon Line

STIHL PolyCut

Precut lengths of nylon line can be fitted to the PolyCut in place of the cutting blades.

STIHL DuroCut, STIHL PolyCut

! WARNING

To reduce the risk of injury, always shut off the engine before refilling the mowing head.

- Fit precut lengths of nylon line in the mowing head as described in the instructions supplied.

Replacing Cutting Blades

STIHL PolyCut

Always check the mowing head for signs of wear before installing new cutting blades.

! WARNING

If there are signs of serious wear, replace the complete mowing head.

The thermoplastic cutting blades are referred to as "blades" in the following.

The mowing head is supplied with illustrated instructions for replacing the blades. Keep the instructions for the mowing head in a safe place.

WARNING

To reduce the risk of injury, always shut off the engine before installing the blades.

- Remove the mowing head.
- Replace blades as shown in the illustrated instructions.
- Mount the mowing head on the machine.

Inspection and Maintenance by User

Changing the Fuel Pickup Body

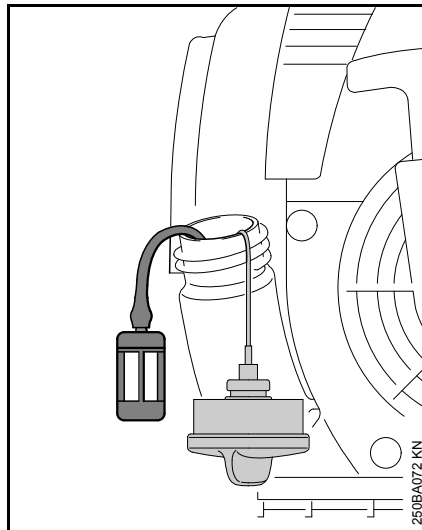

Change the fuel pickup body every year:

- Drain the fuel tank.
- Use a hook to pull the fuel pickup body out of the tank and take it off the hose.
- Push the new pickup body into the hose.
- Place the pickup body in the tank.

Inspections and Maintenance by Dealer

Maintenance Work

STIHL recommends that you have servicing and repair work carried out exclusively by an authorized STIHL servicing dealer.

Antivibration Element

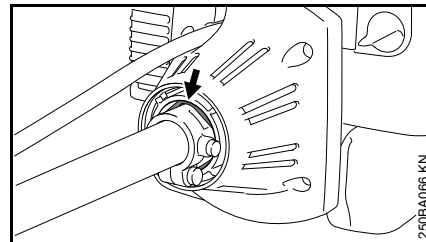

A vibration-absorbing rubber element is installed between the powerhead and the drive tube. Have it checked if there are signs of wear or a noticeable increase in vibration levels.

Maintenance and Care

The following intervals apply to normal operating conditions only. If your daily working time is longer or operating conditions are difficult (very dusty work area, etc.), shorten the specified intervals accordingly.		before starting work	after finishing work or daily	after each refueling stop	weekly	monthly	every 12 months	if problem	if damaged	as required
Complete machine	Visual inspection (condition, leaks)	X		X						
	Clean		X							
	Replace any damaged parts	X							X	
Control handle	Check operation	X		X						
Air filter	Visual inspection					X		X		
	Clean							X		X
	Replace								X	
Manual fuel pump (if fitted)	Check	X								
	Have repaired by servicing dealer ¹⁾								X	
Pickup body in fuel tank	Check							X		
	Replace						X		X	X
Fuel tank	Clean					X		X		X
Carburetor	Check idle adjustment – the cutting attachment must not rotate	X		X						
	Adjust idle speed									X
Spark Plug	Adjust electrode gap							X		
	Replace after every 100 operating hours									
Cooling inlet	Visual inspection		X							
	Clean									X
Exhaust port (FS 250 only)	Have decoked by servicing dealer ¹⁾ after first 139 hours of operation, then every 150 hours of operation									X
All accessible screws and nuts (not adjusting screws)	Retighten									X
Anti-vibration elements	Check ²⁾	X						X		X
	Have replaced by servicing dealer ¹⁾								X	

The following intervals apply to normal operating conditions only. If your daily working time is longer or operating conditions are difficult (very dusty work area, etc.), shorten the specified intervals accordingly.		before starting work	after finishing work or daily	after each refueling stop	weekly	monthly	every 12 months	if problem	if damaged	as required
Cutting attachment	Visual inspection	X		X						
	Replace								X	
	Check tightness	X		X						
Metal cutting attachment	Sharpen	X								X
Gearbox lubrication (with screw plug)	Check					X		X		X
	Replenish									X
Safety labels	Replace								X	
¹ STIHL recommends an authorized STIHL servicing dealer. ² see chapter "Inspections and Maintenance by Dealer", section "Antivibration Elements"										

Minimize Wear and Avoid Damage

Observing the instructions in this manual helps reduce the risk of unnecessary wear and damage to the power tool.

The power tool must be operated, maintained and stored with the due care and attention described in this owner's manual.

The user is responsible for all damage caused by non-observance of the safety precautions, operating and maintenance instructions in this manual. This includes in particular:

- Alterations or modifications to the product not approved by STIHL.
- Using tools or accessories which are neither approved or suitable for the product or are of a poor quality.
- Using the product for purposes for which it was not designed.
- Using the product for sports or competitive events.
- Consequential damage caused by continuing to use the product with defective components.

Maintenance Work

All the operations described in the "Maintenance Chart" must be performed on a regular basis. If these maintenance operations cannot be performed by the owner, they should be performed by a servicing dealer.

STIHL recommends that you have servicing and repair work carried out exclusively by an authorized STIHL

servicing dealer. STIHL dealers are regularly given the opportunity to attend training courses and are supplied with the necessary technical information.

If these maintenance operations are not carried out as specified, the user assumes responsibility for any damage that may occur. Among other parts, this includes:

- Damage to the engine due to neglect or deficient maintenance (e.g. air and fuel filters), incorrect carburetor adjustment or inadequate cleaning of cooling air inlets (intake ports, cylinder fins).
- Corrosion and other consequential damage resulting from improper storage.
- Damage to the machine resulting from the use of poor quality replacement parts.

Parts Subject to Wear and Tear

Some parts of the power tool are subject to normal wear and tear even during regular operation in accordance with instructions and, depending on the type and duration of use, have to be replaced in good time. Among other parts, this includes:

- Cutting attachments (all types)
- Mounting hardware for cutting attachments (rider plate, nut, etc.)
- Deflectors for cutting attachments
- Clutch
- Filters (air, fuel)
- Rewind starter

- Spark plug
- Antivibration elements

Main Parts

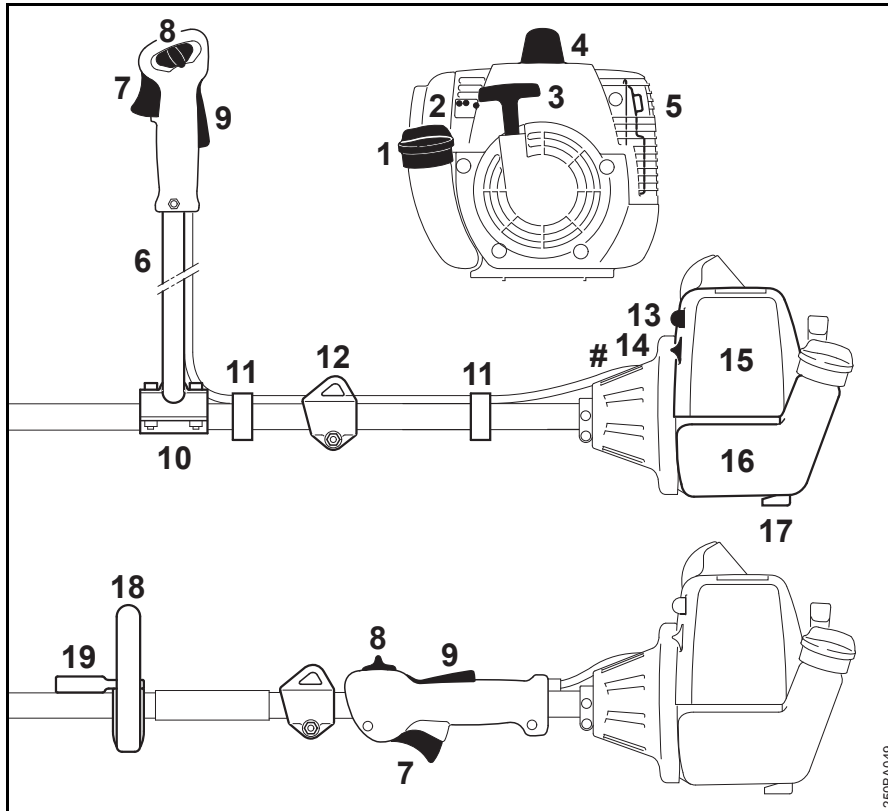

- 1 Tank cap
- 2 Carburetor adjusting screws
- 3 Starter grip
- 4 Spark plug boot
- 5 Muffler
- 6 Bike handle (handlebar)
- 7 Throttle trigger
- 8 Slide control
- 9 Throttle trigger lockout
- 10 Handle support
- 11 Throttle cable retainer
- 12 Carrying ring
- 13 Manual fuel pump
- 14 Choke knob
- 15 Air filter cover
- 16 Fuel tank
- 17 Machine support
- 18 Loop handle
- 19 Barrier bar (country specific)
- # Serial number

250BA049

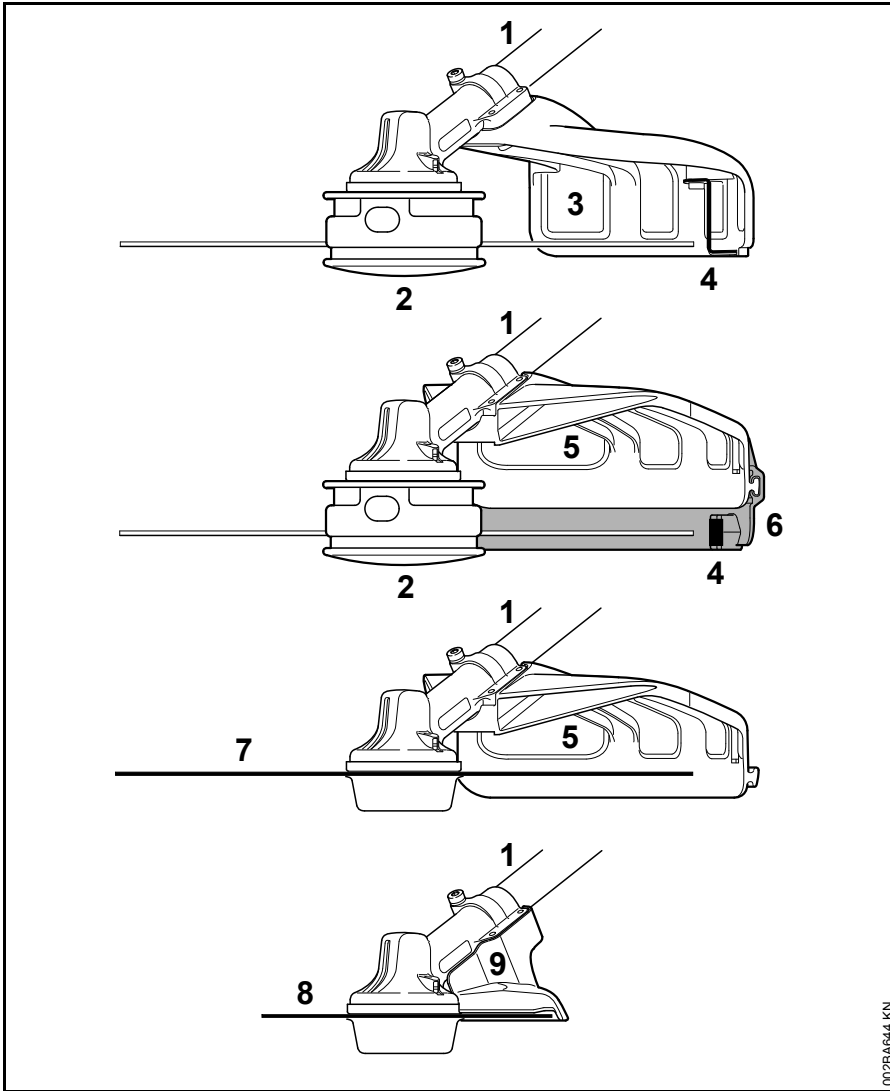

- 1 Drive tube
- 2 Mowing head
- 3 Deflector for mowing heads only
- 4 Line limiting blade
- 5 Deflector for all mowing attachments
- 6 Skirt for mowing heads
- 7 Metal mowing attachment
- 8 Circular saw blade
- 9 Limit stop for circular saw blades only

002BA644 KN

Specifications

Engine

STIHL single cylinder two-stroke engine

FS 120

Displacement:	30.8 cc
Bore:	35 mm
Stroke:	32 mm
Engine power to ISO 8893:	1.3 kW (1.8 bhp) at 9,000 rpm
Idle speed:	2,800 rpm
Cut-off speed (rated):	12,300 rpm

Max. output shaft speed (cutting attachment): 9,150 rpm

FS 250

Displacement:	40.2 cc
Bore:	40 mm
Stroke:	32 mm
Engine power to ISO 8893:	1.6 kW (2.2 bhp) at 9,000 rpm
Idle speed:	2,800 rpm
Cut-off speed (rated):	12,300 rpm

Max. output shaft speed (cutting attachment): 9,150 rpm

Ignition System

Electronic magneto ignition

Spark plug (resistor type):	NGK BPMR 7 A, Bosch WSR 6 F
Electrode gap:	0.5 mm

Fuel System

All position diaphragm carburetor with integral fuel pump

Fuel tank capacity: 640 cc (0.64 l)

Weight

Dry, without cutting attachment and deflector

FS 120:	6.3 kg
FS 120 R:	6.0 kg
FS 250:	6.3 kg

Overall length

without cutting attachment 1765 mm

Features

R Loop handle

Noise and Vibration Data

For further details on compliance with Vibration Directive 2002/44/EC see www.stihl.com/vib.

Sound pressure level L_p to ISO 22868

with mowing head	
FS 120:	101 dB(A)
FS 250:	102 dB(A)
with metal mowing attachment	
FS 120:	99 dB(A)
FS 250:	100 dB(A)

Sound power level L_w to ISO 22868

with mowing head

FS 120:	112 dB(A)
FS 250:	112 dB(A)

with metal mowing attachment

FS 120:	110 dB(A)
FS 250:	112 dB(A)

Vibration measurement $a_{hv,eq}$ to ISO 22867

with mowing head	Handle, left	Handle, right
FS 120:	5.9 m/s ²	4.2 m/s ²
FS 120 R:	8.0 m/s ²	10.5 m/s ²
FS 250:	6.4 m/s ²	3.9 m/s ²
with metal mowing attachment	Handle, left	Handle, right
FS 120:	5.9 m/s ²	3.9 m/s ²
FS 120 R:	6.5 m/s ²	8.9 m/s ²
FS 250:	5.9 m/s ²	3.9 m/s ²

The K-factor in accordance with Directive 2006/42/EC is 2.0 dB(A) for the sound pressure level and sound power level; the K-factor in accordance with Directive 2006/42/EC is 2.0 m/s² for the vibration level.

REACH

REACH is an EC regulation and stands for the Registration, Evaluation, Authorisation and Restriction of Chemical substances.

For information on compliance with the REACH regulation (EC) No. 1907/2006 see www.stihl.com/reach.

Exhaust Emissions

The CO₂ value measured in the EU type approval procedure is specified at www.stihl.com/co2.

The measured CO₂ value was determined on a representative engine in accordance with a standardized test procedure under laboratory conditions and does not represent either an explicit or implied guarantee of the performance of a specific engine.

The applicable exhaust emission requirements are fulfilled by the intended usage and maintenance described in this instruction manual. The type approval expires if the engine is modified in any way.

Maintenance and Repairs

Users of this machine may only carry out the maintenance and service work described in this user manual. All other repairs must be carried out by a servicing dealer.

STIHL recommends that you have servicing and repair work carried out exclusively by an authorized STIHL servicing dealer. STIHL dealers are regularly given the opportunity to attend training courses and are supplied with the necessary technical information.

When repairing the machine, only use replacement parts which have been approved by STIHL for this power tool or are technically identical. Only use high-quality replacement parts in order to avoid the risk of accidents and damage to the machine.

STIHL recommends the use of original STIHL replacement parts.

Original STIHL parts can be identified by the STIHL part number, the **STIHL** logo and the STIHL parts symbol  (the symbol may appear alone on small parts).

Disposal

Observe all country-specific waste disposal rules and regulations.

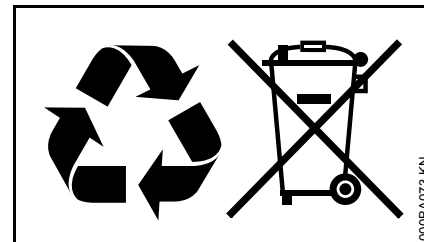

STIHL products must not be thrown in the garbage can. Take the product, accessories and packaging to an approved disposal site for environment-friendly recycling.

Contact your STIHL servicing dealer for the latest information on waste disposal.

EC Declaration of Conformity

ANDREAS STIHL AG & Co. KG
Badstr. 115
D-71336 Waiblingen
Germany

declare in exclusive responsibility that
the product

Category:	Brushcutter
Make:	STIHL
Model:	FS 120 FS 250
Serial identification:	4134
Displacement	
FS 120:	30.8 cc
FS 250:	40.2 cc

conforms to the relevant provisions of
Directives 2006/42/EC, 2014/30/EU and
2000/14/EC and has been developed
and manufactured in compliance with
the following standards in the versions
valid on the date of production:

EN ISO 11806-1, EN 55012,
EN 61000-6-1

The measured and guaranteed sound
power levels were determined according
to Directive 2000/14/EC, Annex V, using
the ISO 10884 standard.

Measured sound power level

FS 120:	112 dB(A)
FS 250:	112 dB(A)

Guaranteed sound power level

FS 120:	114 dB(A)
FS 250:	114 dB(A)

Technical documents deposited at:

ANDREAS STIHL AG & Co. KG
Produktzulassung (Product Licensing)

The year of manufacture and serial
number are applied to the product.

Done at Waiblingen, 28.10.2016
ANDREAS STIHL AG & Co. KG



Thomas Elsner

Director Product Management and
Services



0458-250-0121-E

englisch



www.stihl.com



0458-250-0121-E