

**A319/A320/A321**  
***Flightdeck and systems***  
***briefing for pilots***

*THIS BROCHURE IS PROVIDED  
FOR INFORMATION PURPOSES ONLY  
AND ITS CONTENTS  
WILL NOT BE UPDATED.*

*IT MUST NOT BE USED AS AN OFFICIAL REFERENCE.*

*FOR TECHNICAL DATA OR OPERATIONAL PROCEDURES,  
PLEASE REFER TO THE  
RELEVANT AIRBUS DOCUMENTATION*





# Contents

---

- 1. General**
- 2. Flight deck layout**
- 3. Electrical system**
- 4. Hydraulic system**
- 5. Flight controls**
- 6. Landing gear**
- 7. Fuel system**
- 8. Engine controls**
- 9. Auxiliary power unit**
- 10. Automatic flight system**
- 11. Environmental flight system**
- 12. Electronic instrument system**
- 13. Radio management and communication**
- 14. Maintenance centralized fault display system**





---

# 1. General

# A319/A320/A321 General

---

A319



A320

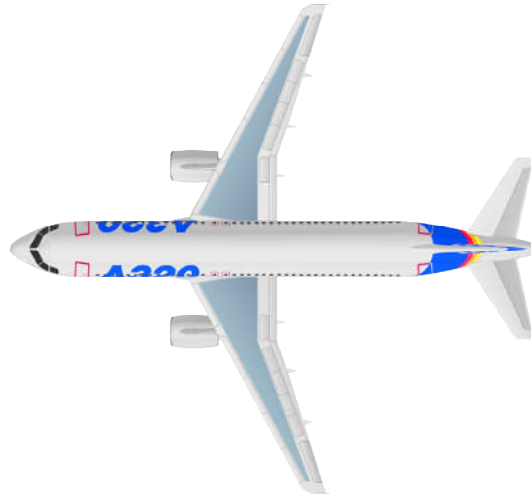

A321



# A319/A320/A321 general

---

	<b>A319-100</b>	<b>A320-100</b>	<b>A320-200</b>	<b>A321-100</b>
Span	34.10m 111ft 10in	33.91m 111ft 3in	34.10m 111ft 10in	
Length	33.84m 111ft	37.57m 123ft 3in		44.51m 146ft
Height	11.76m 38ft 7in			
Fuselage Diameter	3.95m 12ft 11in			
Track	7.59m 24ft 11in			
Max. pax	145	180		220
Max. FL	390			



# A319/A320/A3210general

Model	Engine		Maximum weights (kg)			Operation limits	
	Manuf.	Type	MTOW	MLW	MZFW	Mmo	Vmo
A319-111	CFM	CFM56-5B5	64 000 (options : 68 000 or 70 000)	61 000	57 000	0.82	350kt
A319-112	CFM	CFM56-5B6					
A319-113	CFM	CFM565A4					
A319-114	CFM	CFM56-5A5					
A319-115	CFM	CFM56-5B7					
A319-131	IAE	V2522-A5					
A319-132	IAE	V2524-A5					
A319-133	IAE	V2527-M-A5					
A319 Corporate Jet	CFM	CFM56-5-B6/5B7	75 500	62 500	58 000		
	IAE	V2524-A5/V2527-M-A5					
A320-111	CFM	CFM56-5-A1	73 500 (options : from 68 000 up to 77 000)	64 500	60 500 (option : 61 000)		
A320-211	CFM	CFM56-5A1/5A3					
A320-212	CFM	CFM56-5A3					
A320-214	CFM	CFM56-5B4					
A320-231	IAE	V2500-A1					
A320-232	IAE	V2527-A5					
A320-233	IAE	V2527E-A5					
A321-111	CFM	CFM56-5B1	83 000 (options : 78 000 or 85 000)	73 500 (option : 74 500)	69 500 (option : 70 500)		
A321-112	CFM	CFM56-5B2					
A321-131	IAE	V2530-A5					
A321-211	CFM	CFM56-5B3	89 000	75 000	71 500		
A321-231	IAE	V2533-A5					



# A319/A320/A321 introduction

---

The A319/A320/A321 are narrow body, twin-engined, short / medium-range aircraft, the A319 being the shortened version of the A320, and the A321 being the stretched version of the A320.

They both offer an increased fuselage cross-section leading to an increased revenue potential through :

- greater passenger comfort with wider seats and aisle
- greater overhead baggage volume
- greater cargo capacity
- wide-body compatible container capability
- quicker turnrounds.

Advanced technology applied to aerodynamics, structure, systems and powerplant offer reduced costs through :

- unmatched fuel efficiency
- more accurate flight path control
- reduced maintenance costs
- increased reliability
- reduced trouble-shooting time.

Introduced for airline service in March 1988, the A320 represents the largest single advance in civil aircraft technology since the introduction of the jet engine and results in a major stride forward in airline profitability.

A computer-managed system gives complete protection against excursions outside the normal flight envelope and greatly improves the man / machine interface.





---

## **2. A319/A320/A321flight deck layout**



# A319/A320/A321 flight deck – plan view

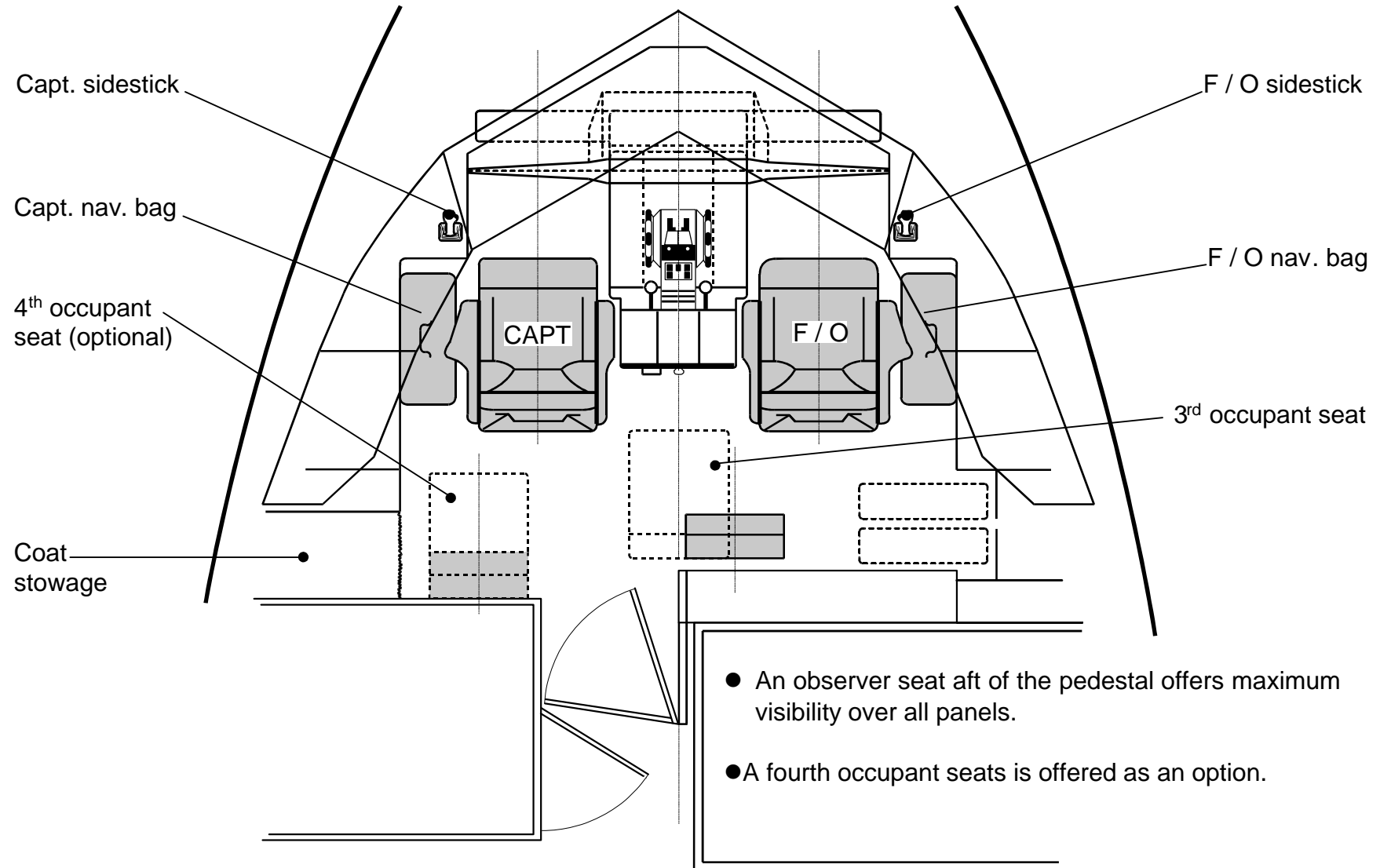

# **A319/A320/A321 flight deck - general arrangement**

---

## **Foward view**

Ceiling light		Reading light
Sun visor		F / O boomset stowage
Assist handle		
Rope stowage		F / O boomset jack panel
Air conditioning outlet		Cup holder
Roller sunblind		Window control handle
		Miscellaneous stowage
Sidestick	Flash light	Waste stowage
Hand microphone	Briefcase lighting	Air conditioning outlet
Ashtray	Nosewheel steering ctl	
Operational manual stowage	Briefcase	
Check list stowage	Portable fire extinguisher	
Flight documents stowage	F / O quick donning oxygen mask	
	3 <sup>rd</sup> occupant quick donning oxygen mask	

# A319/A320/A321 flight deck - general arrangement

## Rear view

### Right corner

Secondary  
circuit breakers

Primary  
circuit breakers

Hand microphone

Hat holder

Jack panel

Headset stowage

Portable  
oxygen bottle

Full face mask

3<sup>rd</sup> occupant seat

Axe

Safety locker

Life vest

### Left corner

Hat storage

Bulbs, fuses stowage

Rain repellent bottle

Coat stowage

Seat unlock

4<sup>th</sup> occupant seat  
(optional)

Life vest

# A319/A320/A321 flight deck – pilot's field of view

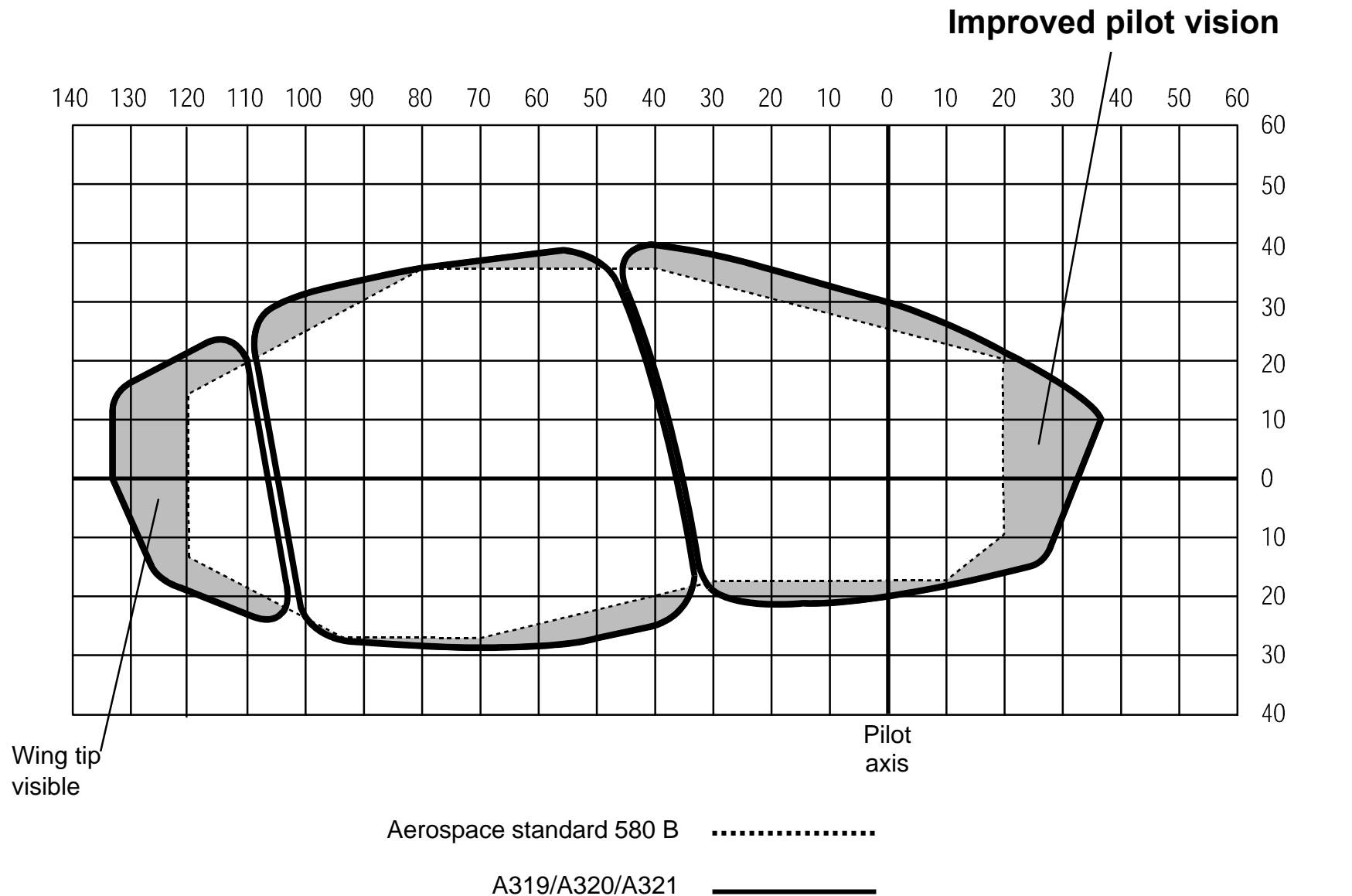



# **A319/A320/A321 flight deck – pilot's field of view**

---

## **Visibility**

- Windows are designed to meet or exceed the Aerospace standard 580 B.

Geometry :

- windshield panels : flat glass
- lateral windows : curved acrylic.

- Clear surface of each window :

Windshield panel	0.52m <sup>2</sup> each
Lateral sliding window	0.36m <sup>2</sup> each
Lateral rear window	0.30m <sup>2</sup> each
Flight deck total	2.36m <sup>2</sup>

- This geometry improves external aircraft monitoring, thereby increasing safety standards :
  - downward visibility in the pilot axis is 20°
  - wing tips visible from respective pilot stations.

# A319/A320/A321 flight deck – main features

---

Control and indication panels in bold outline

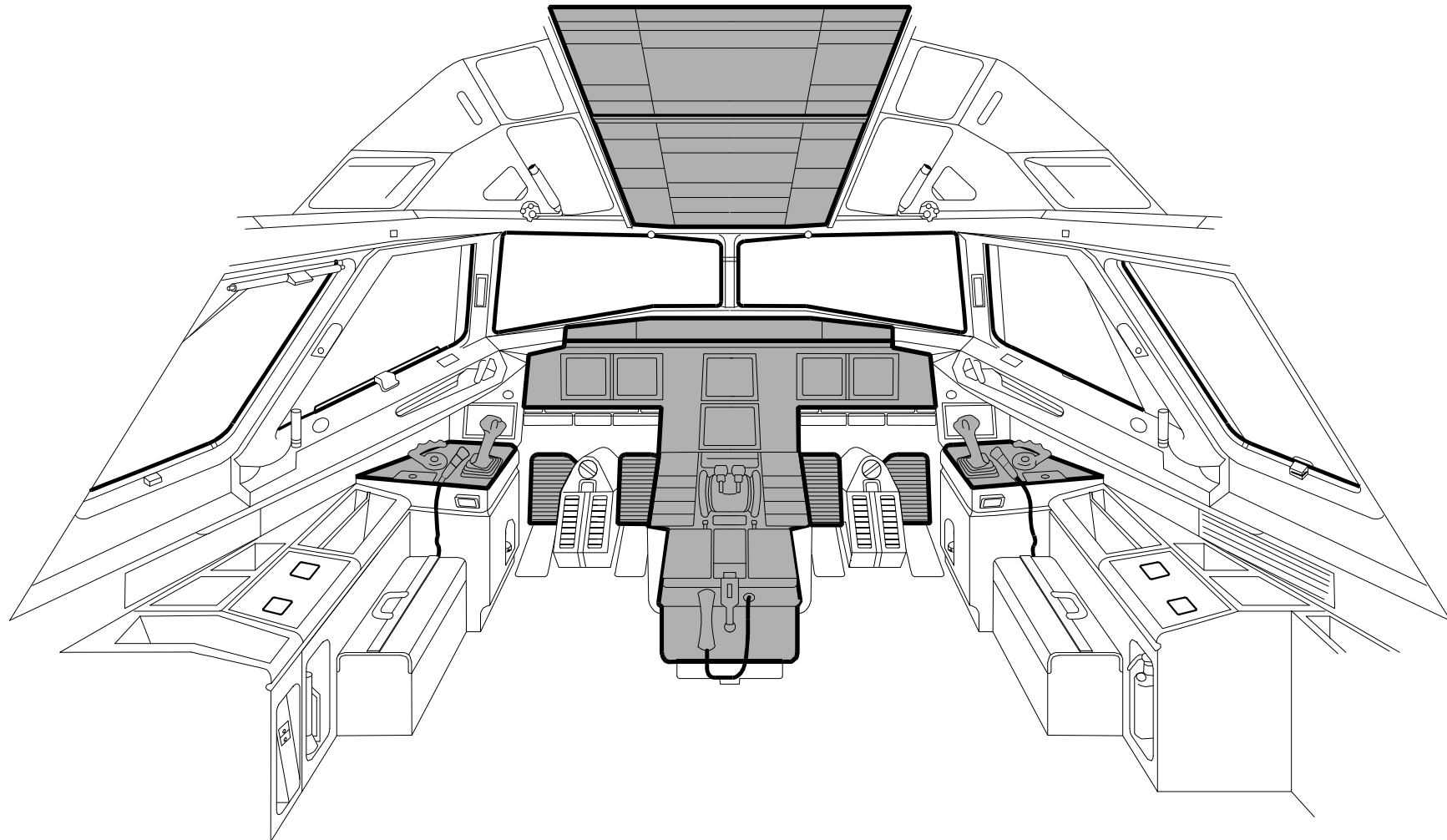

# A319/A320/A321 flight deck – main features

---

- The main features :
  - sidestick controllers which leave the main instrument panel unobstructed
  - six display units (**DU**) interchangeable, switchable and integrated into the same system architecture (EFIS / ECAM)
- The other features evolve directly from the concepts introduced with the A300 / A310 family :
  - ergonomic layout of panels, synoptically arranged according to frequency of use (normal, abnormal, emergency) within easy reach and visibility for both crewmembers
  - philosophy of panels (e.g., “lights out” philosophy for overhead panel)
  - principles of presentation on information (“need to know” concept)
  - monitoring of systems through an Electronic Centralized Aircraft Monitor (ECAM)
  - coherent system of colour coding for EFIS, ECAM and panel lights.

# A319/A320/A321 flight deck – sidestick arrangement

- Sidesticks are installed on the CAPT and F / O forward lateral consoles.
- An **adjustable armrest** to facilitate free wrist movement is fitted on each seat.
- The sidestick works against a spring force proportional to the angular displacement.
- Sidestick includes :
  - radio communication trigger
  - a take-over button for autopilot disconnection and priority take-over.

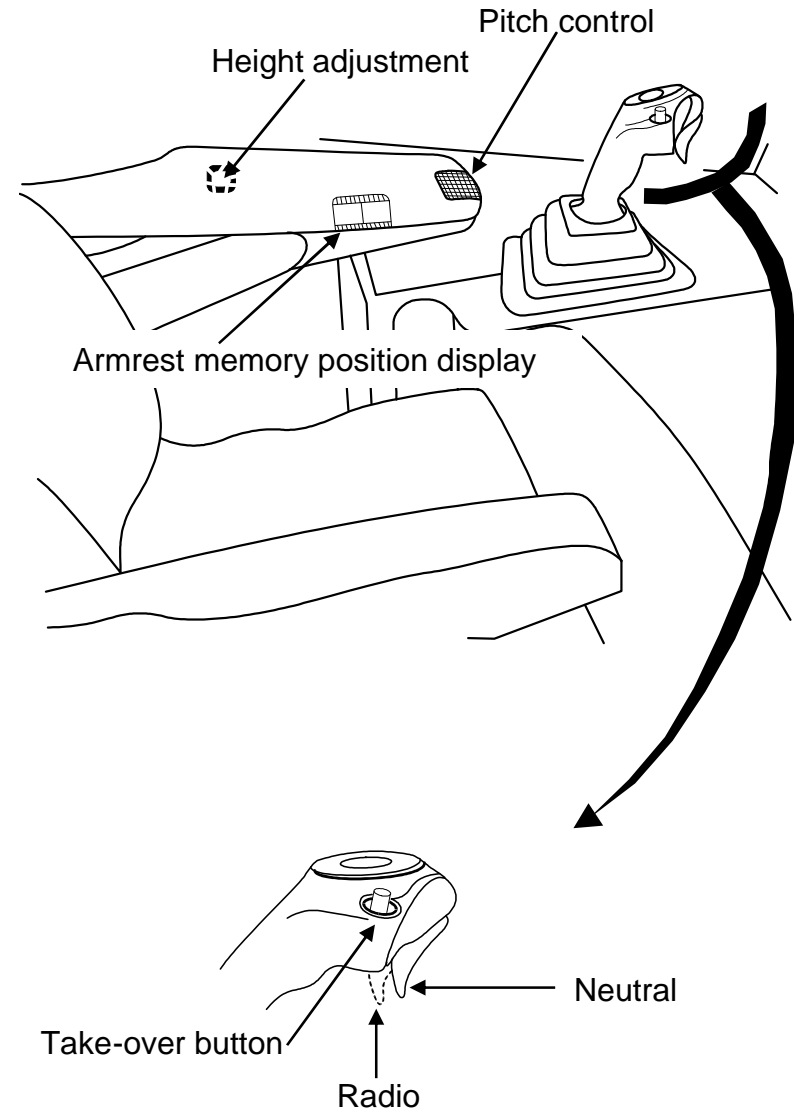

# A319/A320/A321 flight deck – sidestick operation

- Moving the sidestick results in “setting the aircraft trajectory” with a certain level of “g” for the requested manoeuvre depending on the amount of sidestick movement.
- Movement is very precise since back lash and friction are negligible.
- Control of the flight path is performed by the Electronic Flight Control System (**EFCS**) which links the trajectory order with aerodynamic data to stabilize the aircraft and protect it from prohibited attitudes.

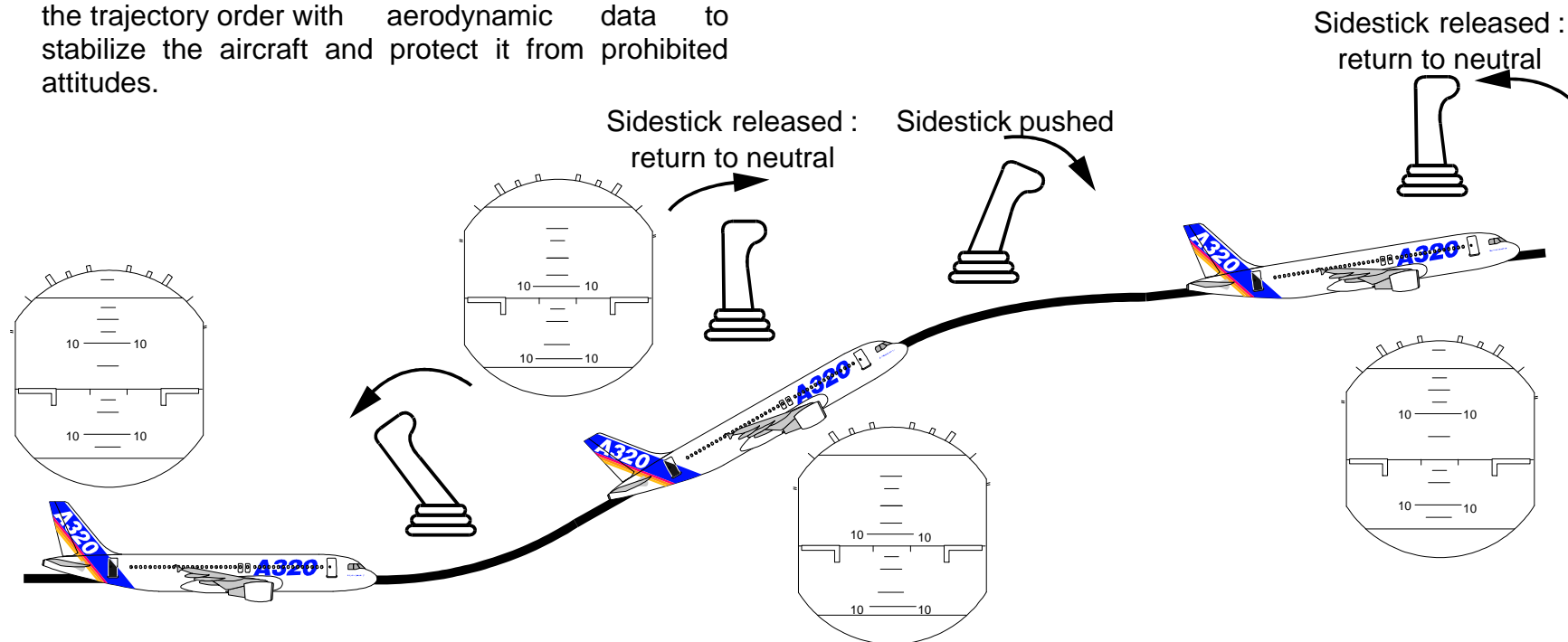

# A319/A320/A321 flight deck – main instruments panels

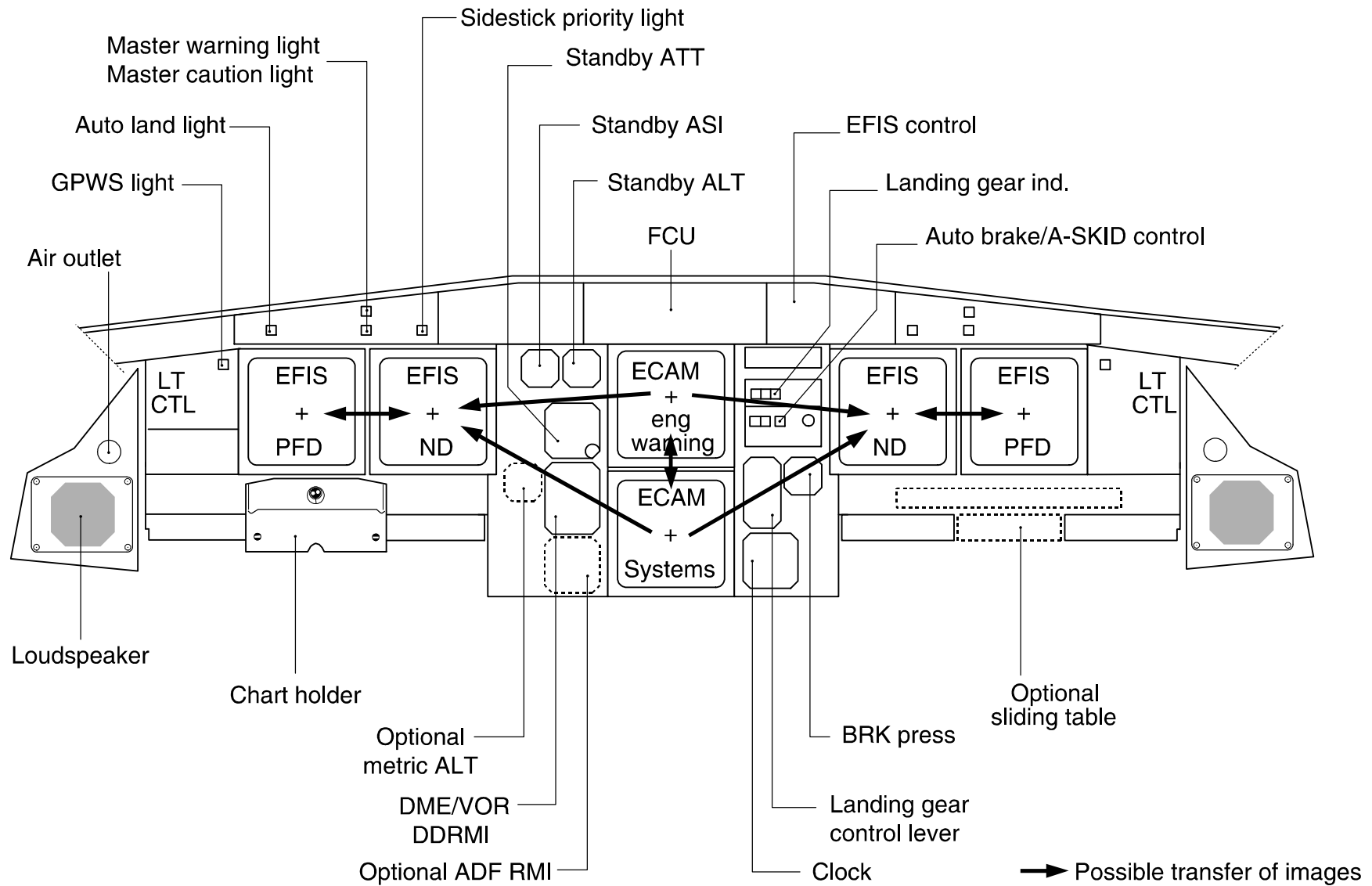

# A319/A320/A321 flight deck – CAPT and F/O panels

---

- The CAPT and F / O panels are mirror image of each other ; both incorporate two side-by-side Display Units (**DU's**) (7.25in x 7.25in) :
  - a Primary Flight Display (**PFD**)
  - a Navigation Display (**ND**).
- This arrangement facilitates :
  - a better visibility on all Dus in normal configuration and in case of reconfiguration (PFD ND or ECAM ND)
  - The possibility to install a sliding table (option) and a footrest in front of each pilot.
- **Primary flight display** includes the complete Basic T with :
  - attitude
  - airspeed / Mach (with all upper ad lower limits)
  - altitude / vertical speed
  - heading
  - AFS status
  - ILS deviation / maker
  - radio altitude

- **Navigation display** offers three modes :
  - **ROSE** mode (ILS, VOR or NAV): heading up, aircraft symbol in screen centre, with radar available,
  - **ARC** mode : heading up, horizon limited to a 90° forward sector, with radar available,
  - **PLAN** mode : north up, display centered on selected waypoint.

Note : In ROSE-NAV, ARC, and PLAN modes, MAP data from FMS is presented.

# A319/A320/A321 flight deck – centre panel

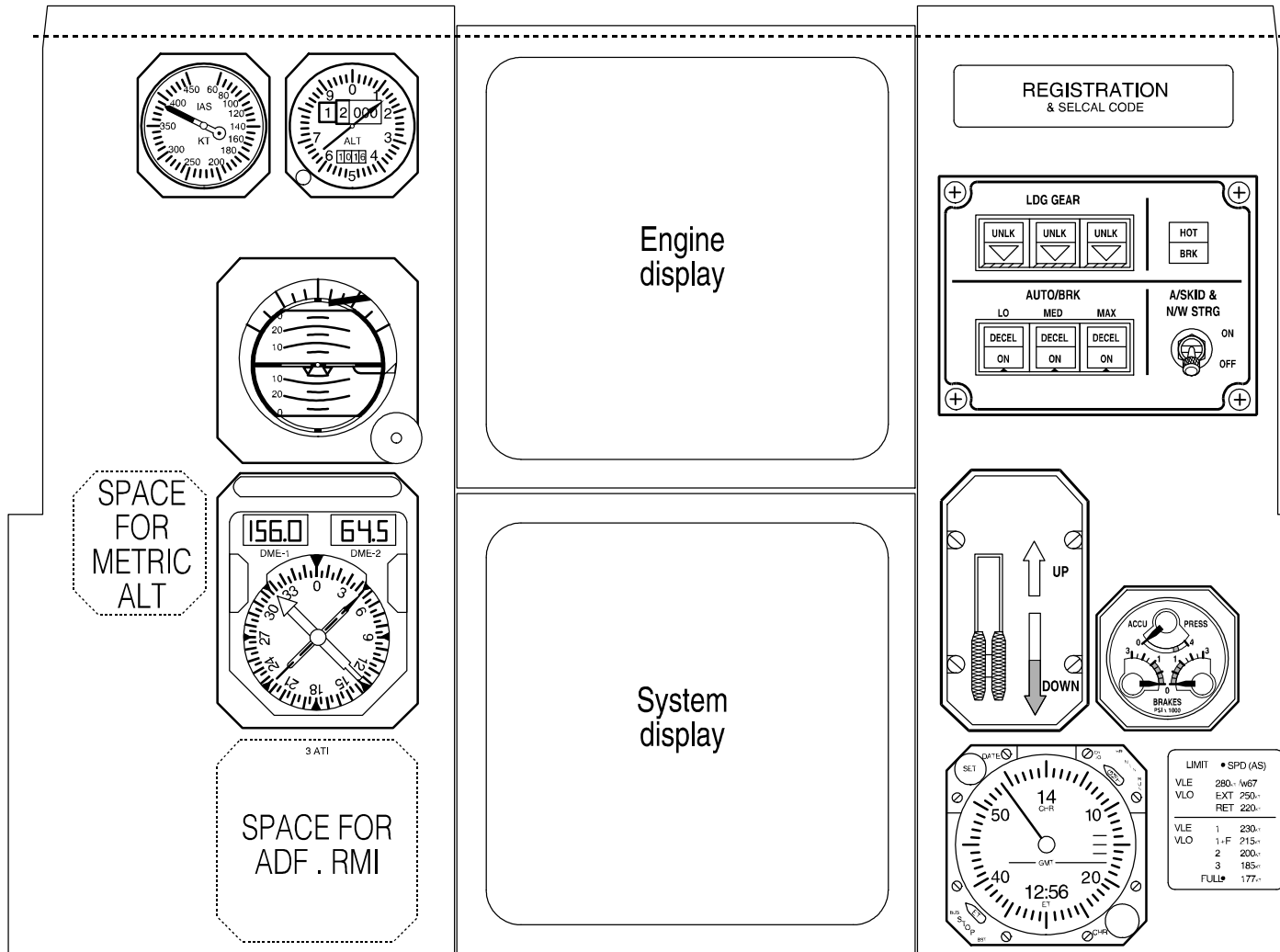



# A319/A320/A321 flight deck – centre panel

---

The centre panel groups :

- two Dus, one above the other, same size and interchangeable with the CAPT and F / O Dus :

- **Engine Display** (DU 1), showing :

- the main engine parameters : N1, EGT; N2 (CFM) or EPR, EGT, N1, N2 (IAE)
- thrust limit and command
- total fuel
- the flaps and slats position
- memo and warning.

- **System Display** (DU 2) showing :

- presentation of system synoptic diagrams
- status of the aircraft (list of all operationally significant items)
- standby instruments
- landing gear control and indications (including brakes)
- clock

# A319/A320/A321 flight deck – glareshield

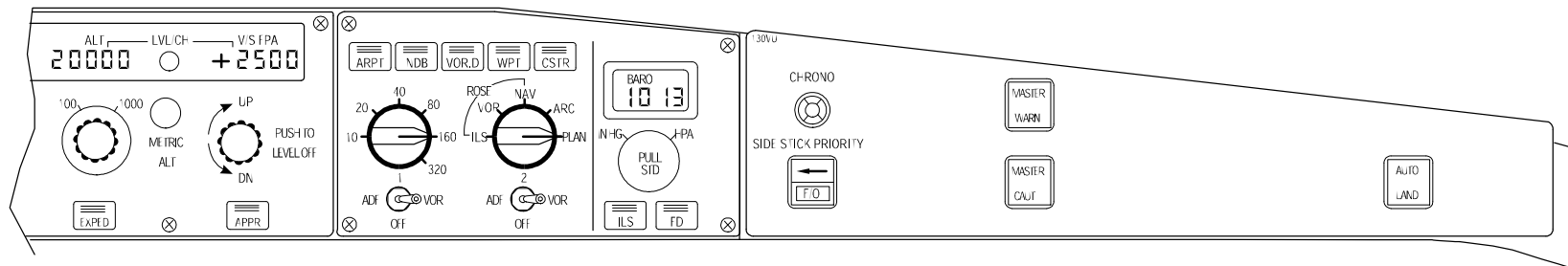
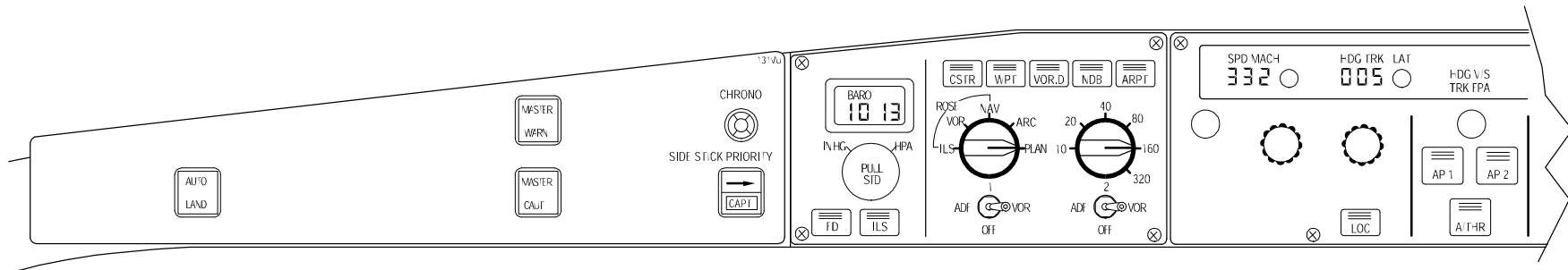

# A319/A320/A321 flight deck – glareshield

---

- The Flight Control Unit (**FCU**) provides short-term interface between the FMGC and crew for :
  - engagement of A / P, FD, ATHR
  - selection of required guidance modes
  - manual selection of flight parameters SPD, MACH, ALT, VSPD, HDG or track.
  
- The EFIS control panels for :
  - selection of desired ND modes (ROSE-ILS, -VOR, ARC, PLAN) and ranges,
  - selection of baro setting.
  
- The master warning, master caution, autoland and sidestick priority lights.

# A319/A320/A321 flight deck – pedestal

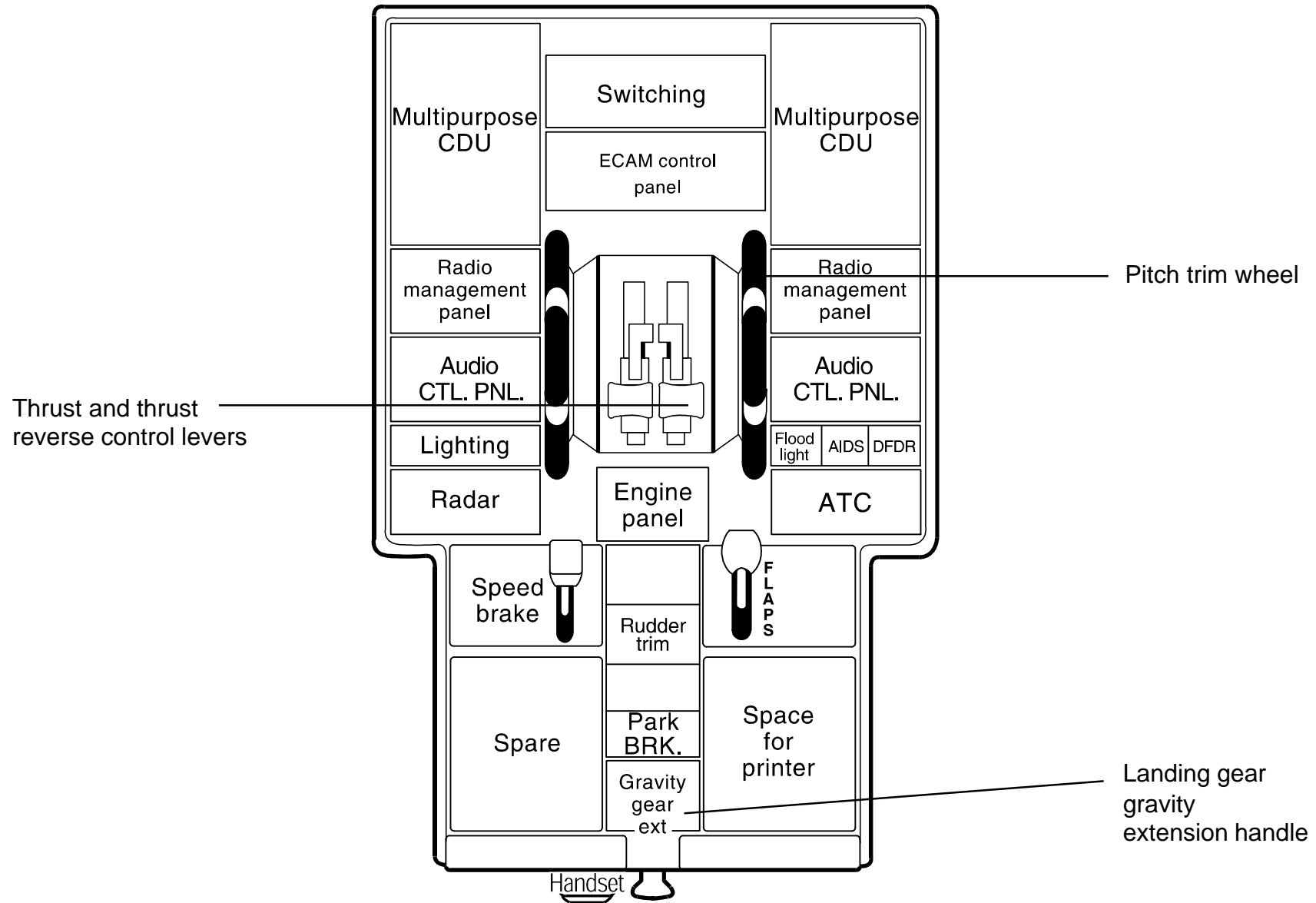

# A319/A320/A321 flight deck – pedestal

---

In addition to the thrust levers and the engine control functions, the main features on the pedestal are :

- The Multipurpose Control and Display Units (**MCDU**) for flight management functions and various other functions such as data link, maintenance etc...
- The Radio Management Panel (**RMP**) for tuning of : all radio communications and the radio navigation as a back-up to the normal operation through the Flight Management and Guidance Computers (**FMGC**).
- The electrical rudder trim.
- A handle at the rear of the pedestal enables the gravity landing gear function, to be operated easily and rapidly.

# A319/A320/A321 flight deck – overhead panel

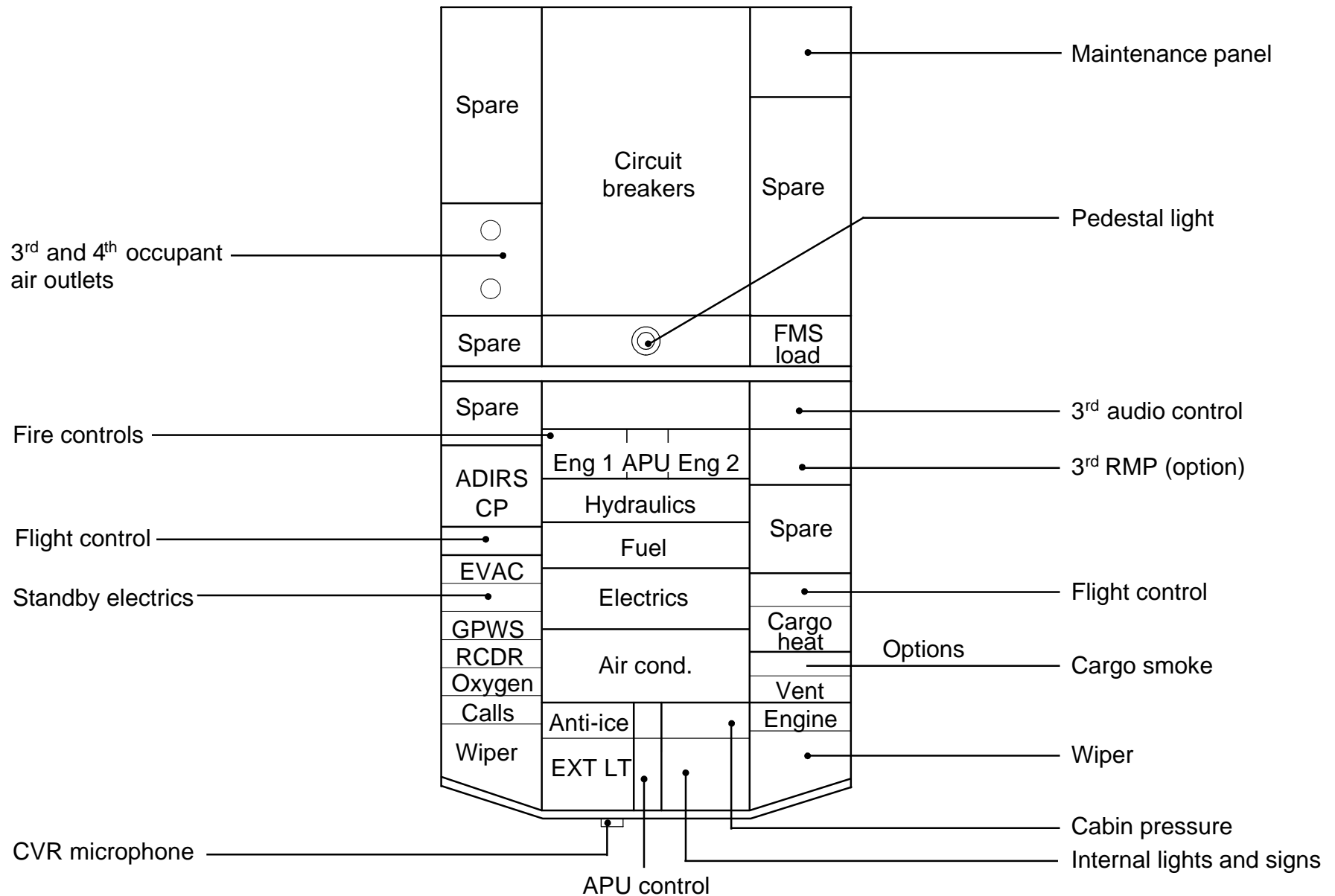

# A319/A320/A321 flight deck – overhead panel

---

- The overhead panel is “single slope” and one inch higher than on previous Airbus aircraft.
- All controls on the overhead panel can be reached by either pilot.
- Two main zones are separated by protective padding :
  - **Forward zone :**
    - for most frequently used functions at the front of the panel
    - for system controls : arranged in three main rows :
      - center row for engine related systems arranged in a logical way
      - lateral rows for other systems
  - **Aft zone**, not used in flight, mainly :
    - for circuit breakers corresponding to essential systems necessitating segregation
    - for a small maintenance panel corresponding to some systems not linked to the Centralized Fault and Display System (**CFDS**).
- **The push-button philosophy** is identical to that already applied on existing Airbus aircraft.







---

# 3. Electricalsystem

# A319/A320/A321 electrical system architecture

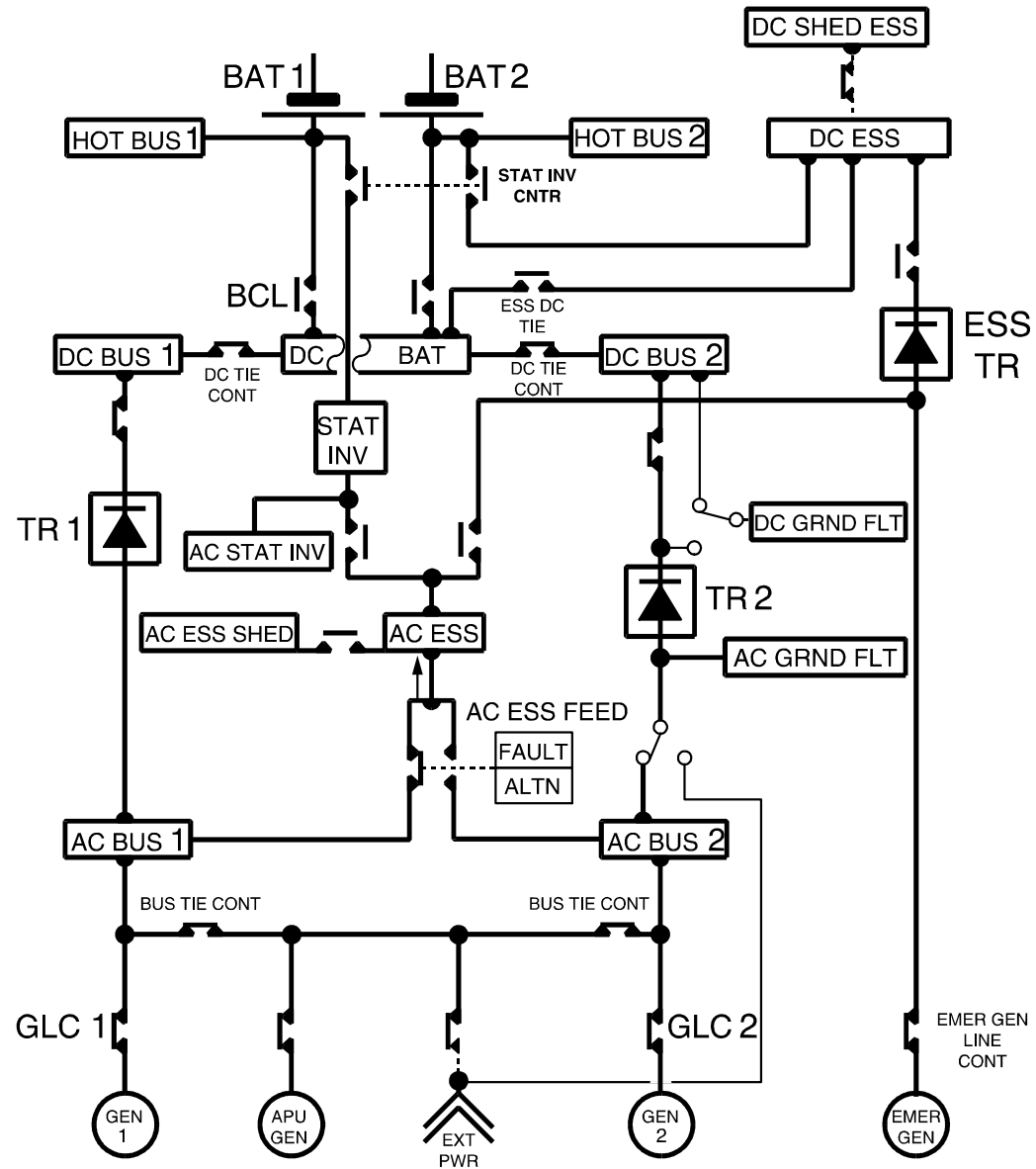

# **A319/A320/A321 electrical system architecture**

---

The electrical power generation comprises :

- Two **engine-driven AC generators**, nominal power 90kVA
- One auxiliary power unit (**APU**) **AC generator** nominal power 90kVA
- One **emergency generator** nominal power 5kVA, hydraulically driven by the Ram Air Turbine (**RAT**), automatically deployed in case of main generators loss
- One **ground connector**, power 90kVA.
- DC network supplied via three identical Transformer / Rectifier Units (**TRU**) :
  - two of them are normally used
  - the third is used :
    - in emergency configuration (loss of main AC generators)
    - in case of TR 1 or TR 2 failure
- Two **batteries**, nominal capacity 23Ah each
  - on ground : to provide an autonomous source mainly for APU starting
  - in emergency configuration to feed some equipment :
    - during RAT deployment
    - after landing gear extension (only for A320).

# A319/A320/A321 normal electrical flight configuration

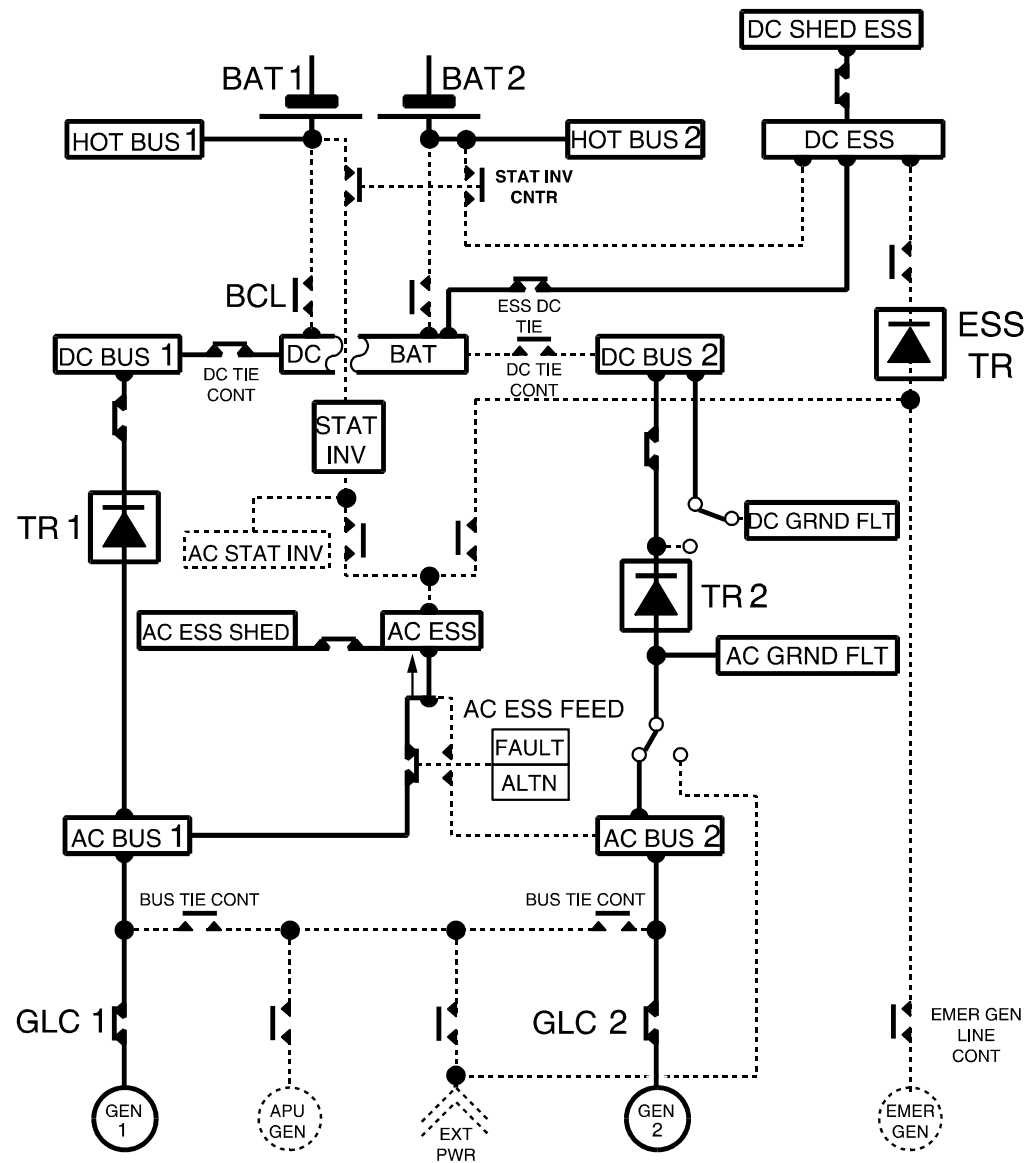

# **A319/A320/A321 normal electrical flight configuration**

---

- In normal configuration, both normal AC systems are split
- Each engine-driven generator supplies its associated AC BUS via its Generator Line Contactor (GLC).
- AC ESS BUS is normally supplied from AC BUS via a contactor.
- DC BAT BUS and the DC ESS BUS are normally powered by the TR 1.
- Two batteries are connected to the DC BAT BUS via the Battery Charge Limiter (BCL).
- Each battery has its own HOT BUS bar (engine / APU firesquib, ADIRS, CIDS, ELAC 1, SEC 1, slide warnings, parking brake etc).

# A319/A320/A321 normal electrical flight configuration

## Loss of main electrical generators – EMER GEN running

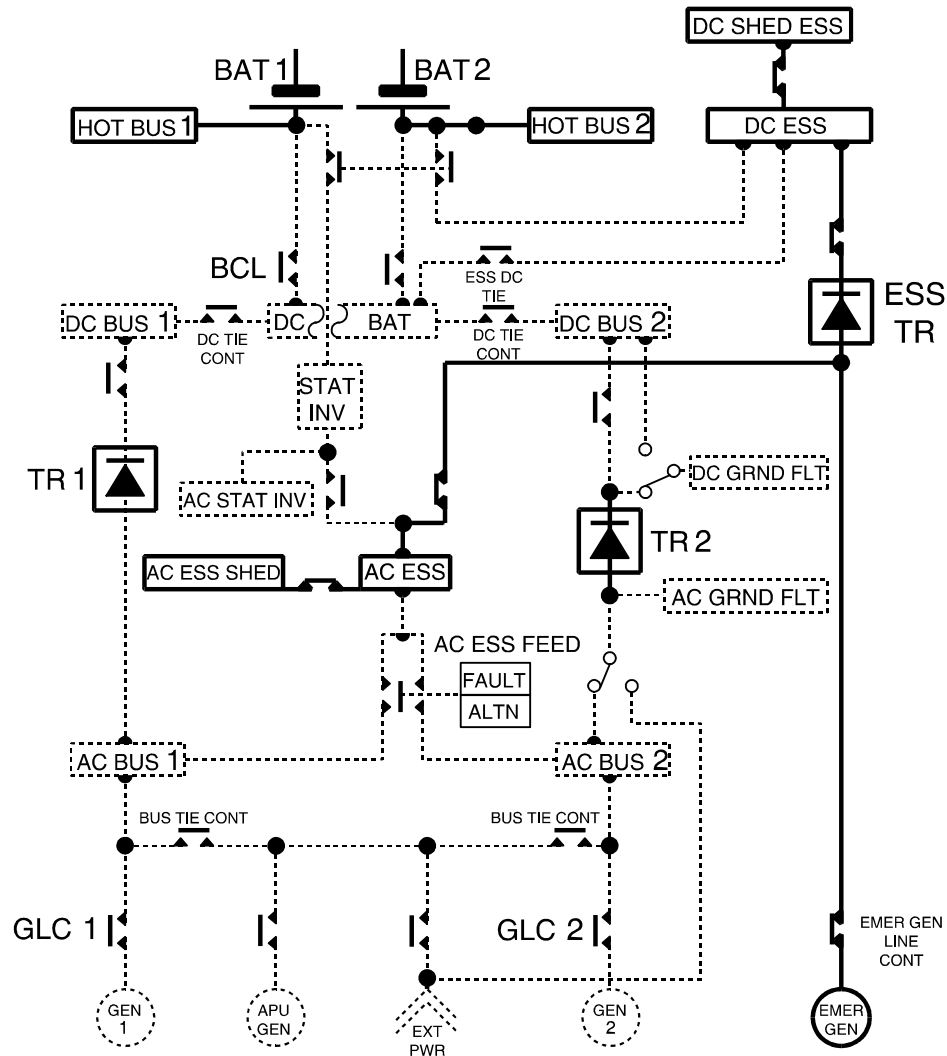

# **A319/A320/A321 normal electrical flight configuration**

---

- In case of failure, the failed generator is automatically replaced by :
  - the APU generator if available
  - the other main generator with automatic partial galley load shedding.
- In case of total loss of all main generators, the RAT is automatically extended and drives the emergency generator via a hydraulic motor.

The EMER GEN supplies the AC ESS BUS and the DC ESS BUS via the ESS TR.

The ECAM WD remains powered, with associated procedures presented.

Alternate law is operative through ELAC 1 and SEC 1.

# A319/A320/A321 electrical – control and display

## Control panel

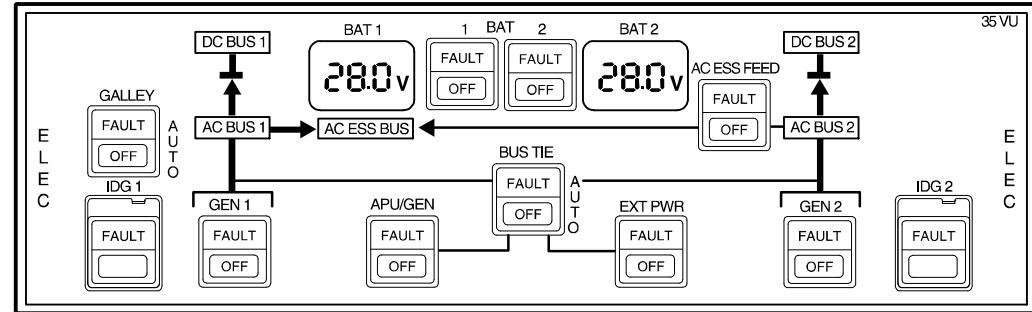
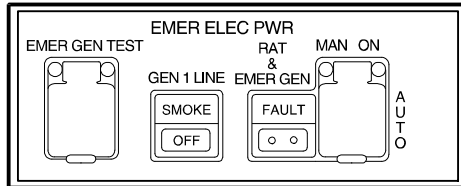

## System display :

ELEC system page

Normal configuration

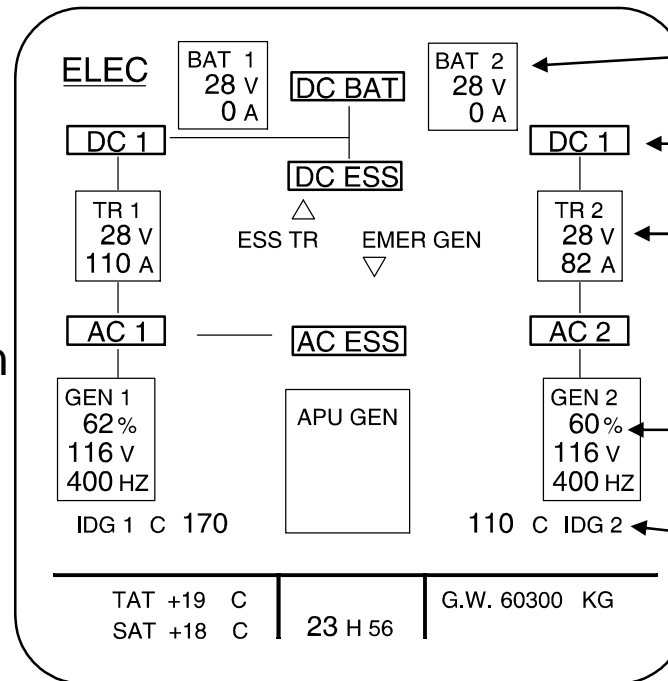

Batteries indication

Buses indication

Transformer / Rectifier

Generator indication

Integrate Drive  
Generator indications



# A319/A320/A321 cockpit circuit - breakers

- Circuit breakers (C / Bs) are constantly monitored and the tripping of a C / B will be clearly indicated :

- either through
- activation of a system warning
  - a failure test
  - an abnormal instrument configuration

or, for C / Bs monitored by the ECAM system :

- six zones have been defined
- each time a C / B trips, the corresponding zone is identified

## Overhead panel

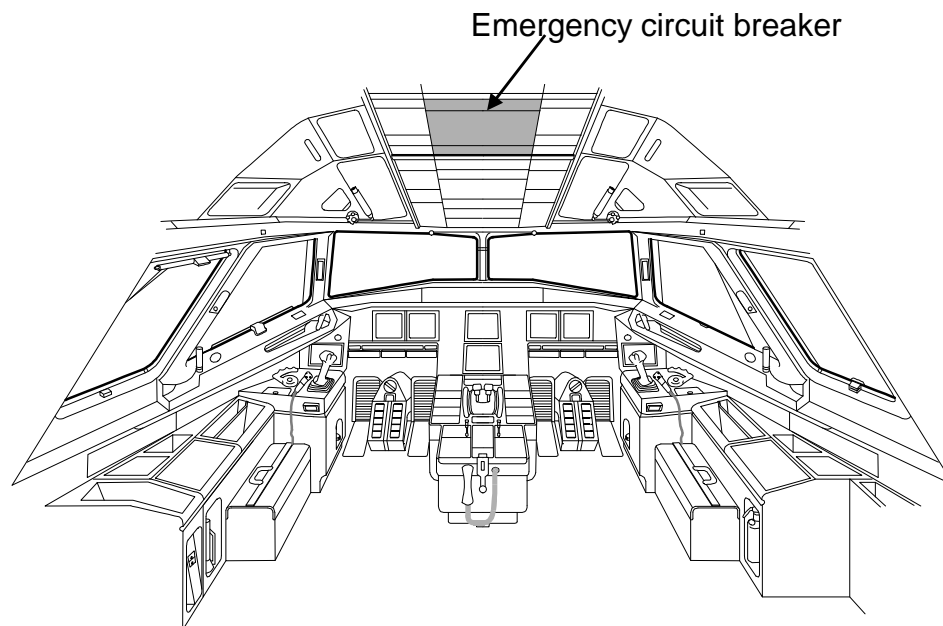

## Rear right panel

Secondary circuit breakers  
(aircraft systems)

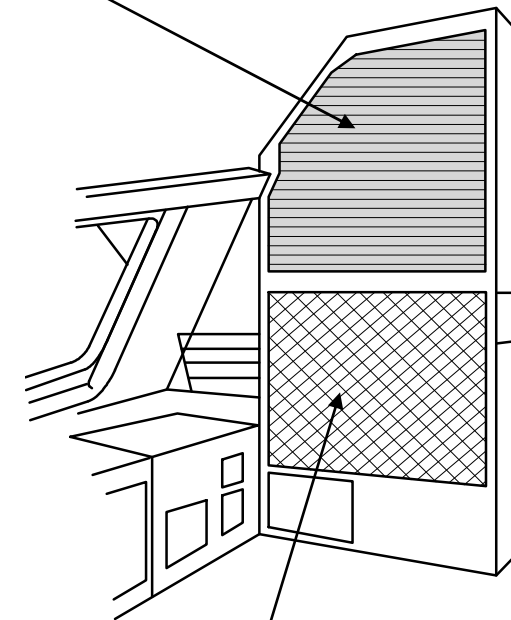

Primary circuit breakers  
(electrical generation)





---

# 4. Hydraulic system

# A319/A320/A321 hydraulic system architecture

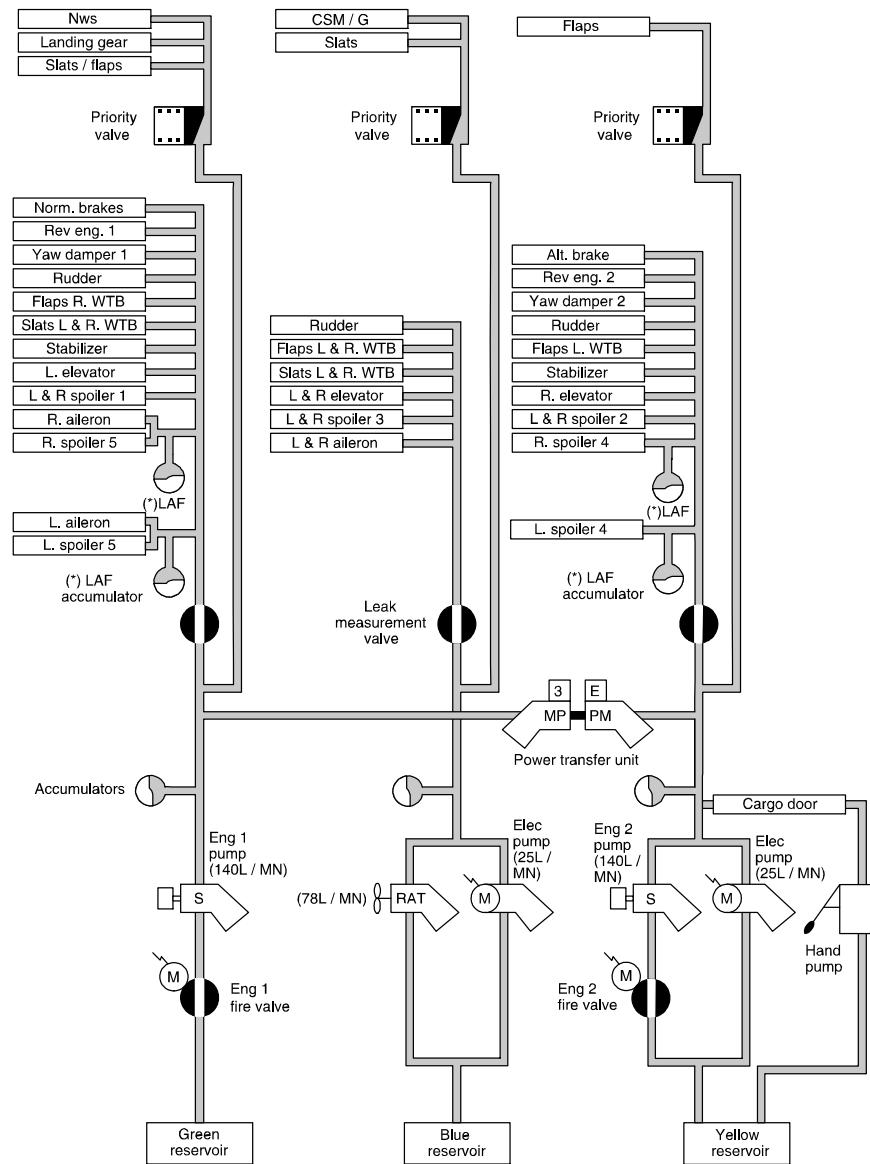

# A319/A320/A321 hydraulic system - general

---

- Three fully independent systems : **Green, Yellow, Blue.**
- Normal operation :
  - two engine-driven pumps (one each - Green and Yellow systems)
  - one electric pump (Blue system)
- Abnormal operation :
  - **if** engine No. 1 inoperative or Green pump failed : then Green system pressurized by the reversible Power Transfer Unit (**PTU**)
  - **if** engine No. 2 inoperative or Yellow pump failed : then Yellow system pressurized by the reversible PTU
  - **if** Yellow system pump inoperative and PTU failed : then an electric pump will pressurize the Yellow system.
  - if case of dual engine failure or total electrical power loss : the Ram Air Turbine (**RAT**) will pressurize the Blue system.
- On ground :
  - Blue and Yellow systems may be pressurized by electric pumps.  
A handpump (operated from the ground on the yellow system) facilitates manoeuvring of the cargo doors.
  - Green/Yellow system may be pressurized by the PTU.



# A319/A320/A321 hydraulic - control and display

Control panel

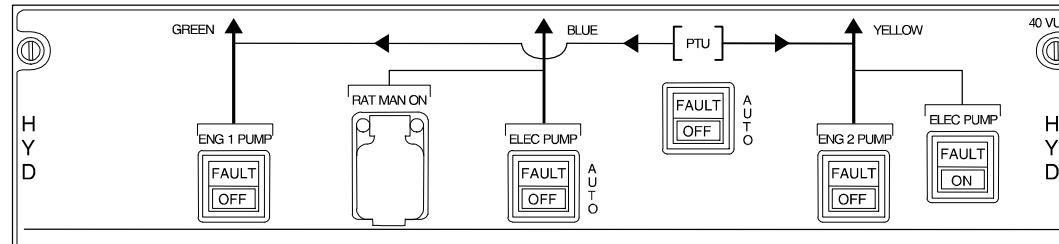

System display :

HYD system page

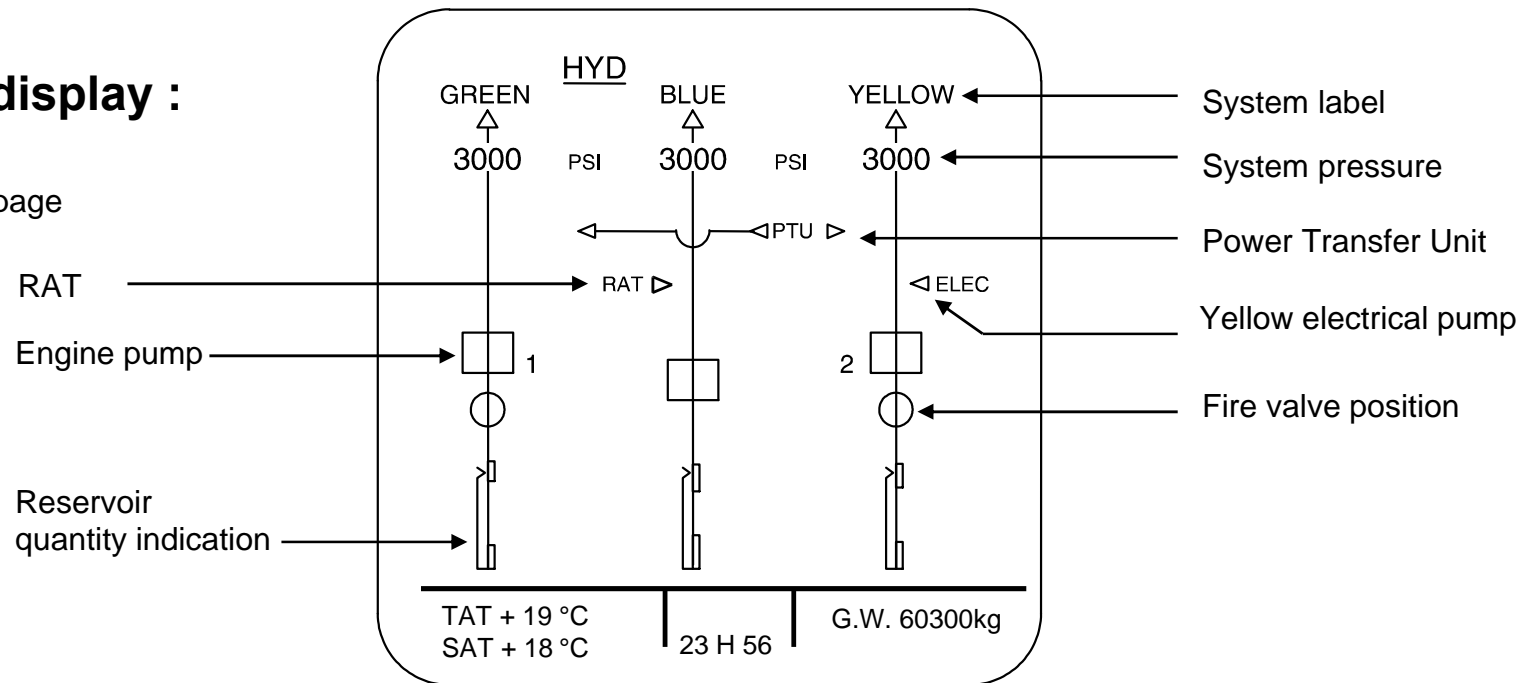







---

# 5. Flightcontrols



# A319/A320/A321 EFCS advantages

---

## The Electrical Flight Control System (EFCS) provides :

- Safety improvements (stall / windshear / overstress / overspeed protection)
- Economical aspects
  - weight saving =  $\Delta W > 200\text{kg}$  considering the impact on AFS  
A319/A320/A321 plus same weight gain on wing structure due to integration of load alleviation function (A320 only).
  - maintenance costs decreased
  - training costs decreased
  - production costs decreased
- Improvements in handling and comfort
  - flight handling improvement
  - new cockpit concept

# A319/A320/A321 flight controls surfaces

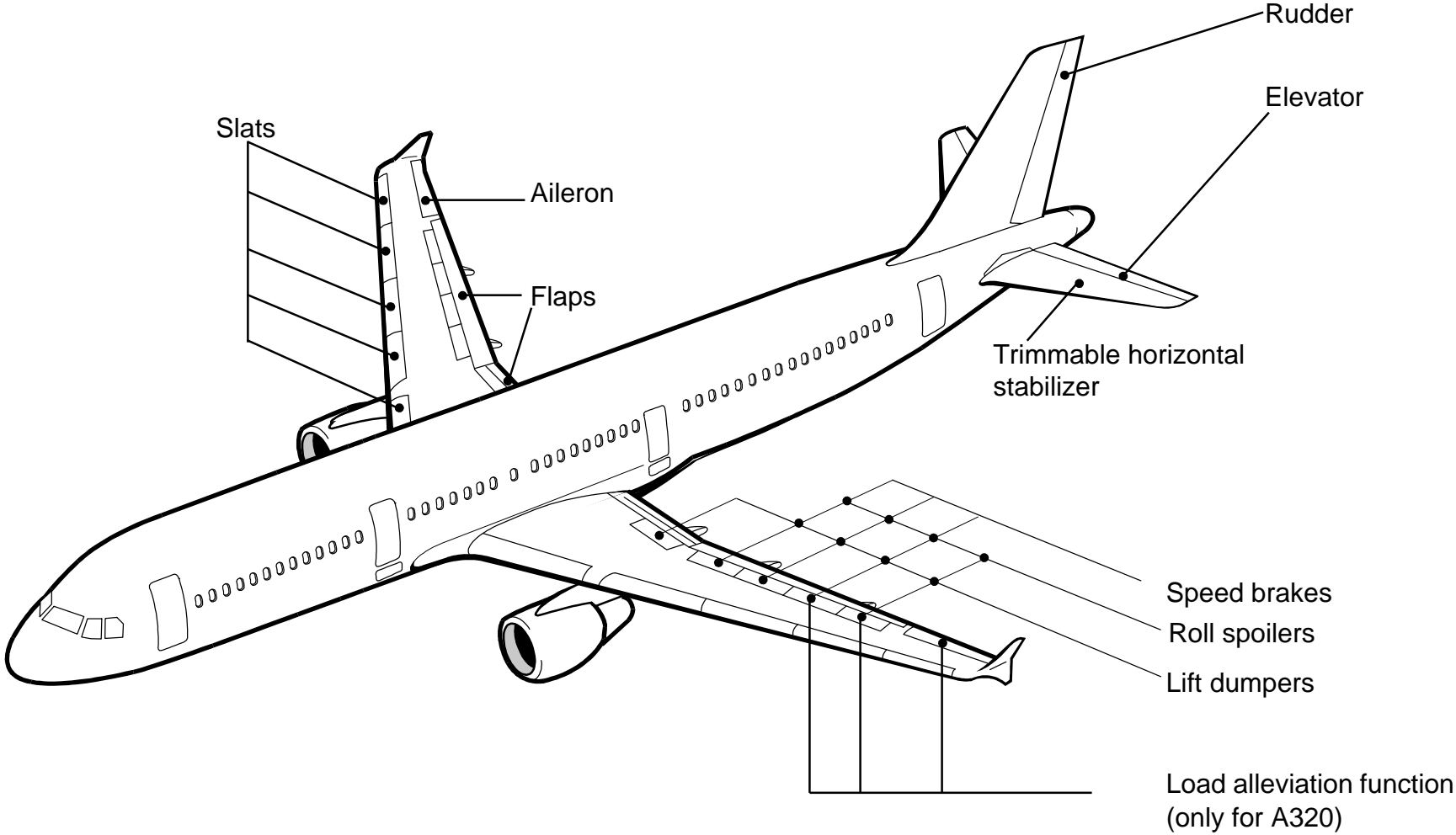

# A319/A320/A321 flight controls surfaces

---

- Control is achieved through conventional surfaces
- All the surfaces are hydraulically actuated
- Roll and pitch control is electrical :
  - elevator
  - ailerons
  - roll spoilers
  - trimmable horizontal stabilizers
  - slats and flaps (single flap surfaces for A320 and A319, double slotted surfaces for A321)
  - speedbrakes / ground spoilers.
- Yaw control is mechanical :
  - rudder (yaw damping, turn coordination and trim are electrically ensured)
- Mechanical back up :
  - trimmable horizontal stabilizers

# A319/A320/A321 EFCS command principle

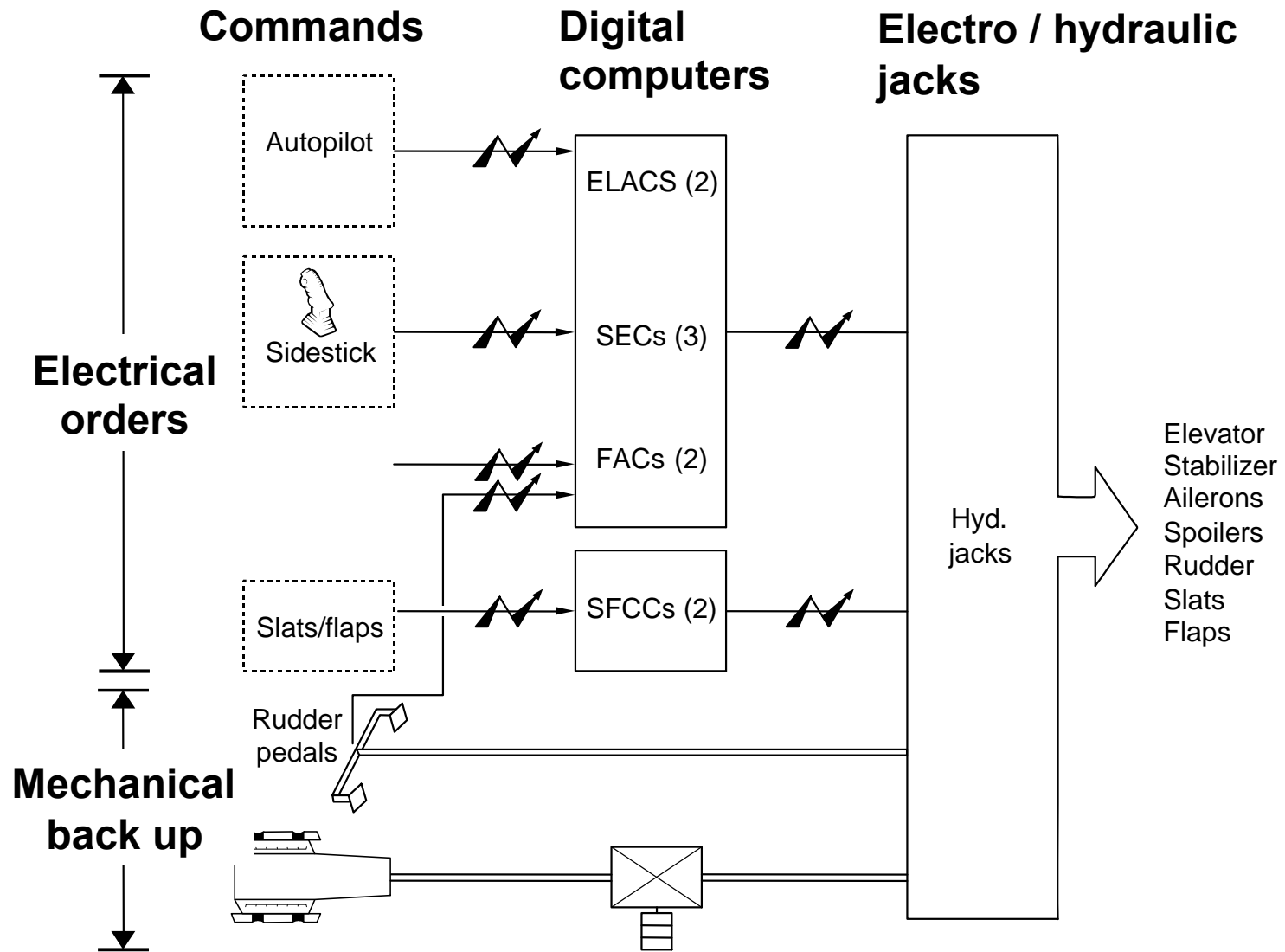

# A319/A320/A321 EFCS computer

---

Flight control is achieved by three types of computer :

- Two **ELACs** (Elevator Aileron Computer) to ensure commands of :
  - normal elevator and stabilizer
  - aileron
- Three **SECs** (Spoiler Elevator Computer)
  - three computers achieve spoiler control
  - two of them are devoted to standby elevator and stabilizer control
- Two **FACs** (Flight Augmentation Computer)

Two computers which achieve electrical rudder control and characteristics speeds calculation for displays on PFD

In addition

- two **SFCCs** (Slats Flaps Control Computer)
- two **FCDCs** (Flight Control Data Concentrator) acquire data from ELACs and SECs and send them to ECAM and CFDS.





# Classic and Fly-by-Wire (FBW) controls compared

---

## Classic flight controls

- Directly proportional relationship between pilot stick input and control surface position.
- Aircraft response depending on aircraft dynamics and flight envelope area coverage.
- Airworthiness and aircraft performance requirements leading to increasingly complex system :
  - variable artificial feel to modulate pilot forces with flight conditions (efforts / g),
  - hydraulically powered servocontrols, servoed autopilots, control wheel steering,
  - stall protection devices (stick shaker, stick pusher),
  - stability augmentation systems (Mach trim, speed trim, angle-of-attack trim, roll and yaw damping).

## Fly-by-wire controls

- No directly proportional relationship between pilot stick input and control surface position.
- Computers' response to stick input modulating servocontrolled jacks to satisfy :
  - normal, alternate or direct laws (pitch, roll and yaw axes),
  - optimised flight control characteristics (easy handling, good stability),
  - improved safety :overspeed, stall, windshear, manoeuvre and attitude protections.

# A319/A320/A321 C\* law description

---

Autotrim function

Control surface autotrim  
function

Ground or  $Z < 100$  ft\*

Ground

Electric trim

GAIN

GAIN  $NZ$   
( $\theta$  and  $\emptyset$  compensated)

GAIN

$\theta$

$Z < 100$  ft\*

THS

Elevator

$Z < 100$  ft\*

\* Before landing

# A319/A320/A321 normal law – pitch axis

---

- Manoeuvre demand law as basic flight mode
  - neutral speed stability with full flight envelope protection
- Vertical load factor control proportional to stick deflection : C\* law
  - independent of speed, weight, center of gravity ;  
stick displacement :  $\Delta N_z = n \quad N_z = n + 1g$   
stick neutral :  $\Delta N_z = 0 \quad N_z = 1g$
- Flight path stability instead of speed stability
  - control inputs are made to alter the flight path, not to hold it.
- Medium-term flight path stability :
  - maintenance of parallel trajectory 1g in pitch even after atmosphere disturbance.
- Automatic pitch trim eliminating need to correct for speed or configuration changes :
  - electric autotrim function holding elevator position for constant flight path,  
- control surface autotrim function returning elevators to the THS trail.
- Automatic elevator for bank angle compensation up to 33°.

# A319/A320/A321 normal law – pitch axis

---

- Adaptation of basic control law objectives to :

- Ground phase : **ground mode**

Direct relationship between stick and elevator available before lift-off and after touch-down

- Take-off phase : **take-off mode**

For smooth transition, blend of ground phase law and  $N_z$  command law over 5 seconds after lift off.

- Landing phase : **landing mode**

At 50ft the attitude is memorized as reference pitch attitude.

At 30ft this value is progressively reduced to 2° nose down to induce gentle positive pilot action for a conventional flare.

# A319/A320/A321 normal law – roll and yaw axes

---

- Roll rate demand (15° / Sec max.) as basic flight mode :
- Coordinated roll and yaw surfaces deflections :
  - to achieve and maintain bank angle up to 33°, stick released
- Bank angle protection above 33° :
  - positive spiral stability restored up to 67° inside normal flight envelope
  - limit of 67° bank angle
- Lateral control laws providing handling quality features such as :
  - bank angle resistance to disturbance, stick free,
  - precise piloting
  - good turn coordination,
  - dutch roll damping,
  - sideslip minimization.
- Sidestick free with pedal deflection results in stabilized sideslip and bank angle facilitating “de-crabbing” in crosswind landings.
- Engine failure or aircraft asymmetry compensation consisting of :
  - If no pilot action :
    - stabilized sideslip and bank angle followed by,
    - automatic rudder trimming to compensate asymmetric thrust
    - slowly diverging heading.
  - Recommended action :
    - zero sideslip target with pedals (take-off, go-around),
    - heading stabilization with stick input,
    - steady flight stick free / no pedal forces (rudder trim).
- Adaptation of basic control law objectives to :
  - Ground phase : **ground mode**
    - Direct relationship between stick and roll control surfaces
    - Rudder : mechanical control from pedals + yaw damper function
- Transition from **ground to in-flight law** (and vice versa)  
Switching over in 0.5 second after lift-off or touch-down.



# A319/A320/A321 alternate law

---

- Flight mode as basic control laws :
  - pitch axis : as normal law, stick deflection to change  $N_z$ ,
  - roll/yaw axes : direct stick-to-roll-surface relationship, speed, configuration and surface availability dependent,
  - automatic pitch trim.
  
- Loss of flight envelope protections except :
  - manoeuvre protection against excessive load factor
  - low speed stability
  - conventional aural stall and overspeed warning
  
- Reversion of basic control law :
  - alternate law not being adapted to landing phase - automatic reversion to direct law after landing gear extension.
  
- Automatic reconfigurations after loss of basic control law in either axis.

# **A319/A320/A321 direct law and mechanical back-up**

---

## **Direct law**

- On all axes :
  - direct stick to elevator or roll control surface relationship,
  - center of gravity, configuration and surface availability dependent.
- Manual trimming through trim wheel :
  - amber message on PFD (“USE MAN PITCH TRIM”)
- Loss of all flight envelope protections :
  - conventional aural stall and overspeed warning.
- Automatic reconfiguration after loss of basic control law in either axis.

## **Mechanical back-up**

- Highly improbable operational necessity.
- To sustain the aircraft during a temporary complete loss of electrical power.
- Longitudinal control of the aircraft through trim wheel. Elevators kept at zero deflection..
- Lateral control from pedals.
- Manual trimming through trim wheel :
  - red message on PFD (“MAN PITCH TRIM ONLY”)



# Performance comparison of sidestick/FBW and conventional controls

---

- A300 flying testbed equipped with dual sidestick/FBW system (left side) and control column conventional flight control system (right side).
- Two pilots twice flew each of the following three flight conditions in well-specified and demanding experimental circuits :
  - Flight Director (FD) : FD and autothrottle system on,
  - ILS (raw data) : FD and autothrottle system off,
  - NDB (non-precision) : FD, autothrottle and ILS off.
- The following measurements of recorded flight parameters were calculated when appropriate and compared for flying with the sidestick and conventional controls :
  - Mean : average of 1 second values,
  - Standard deviation : amount of variation around the mean,
  - Rate zero : number of sign changes per minute,
  - Reversal rate : number of direction reversals per minute.



# Performance comparison of sidestick/FBW and conventional controls

### Roll and pitch angles Standard deviation

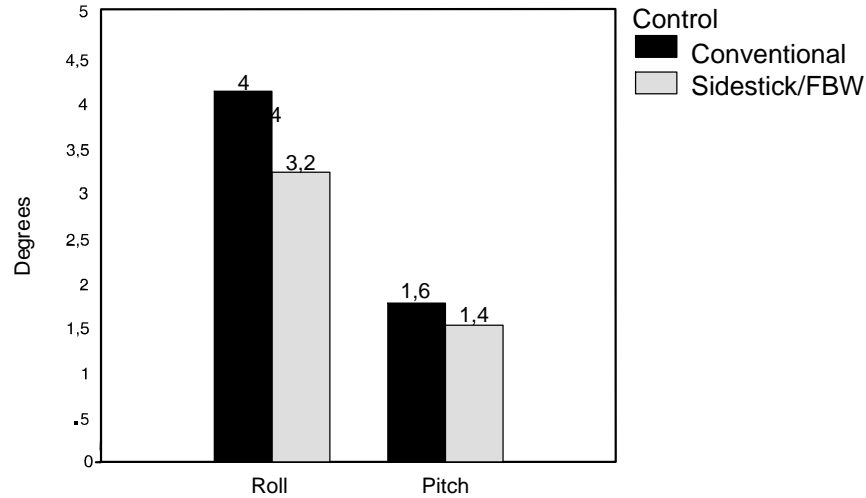

### Roll, pitch and yaw rates Standard deviation

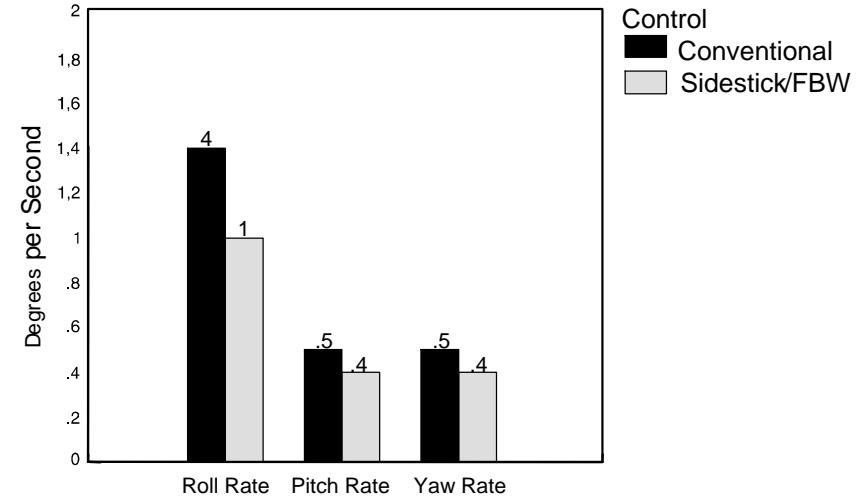

### Acceleration Transitions through zero

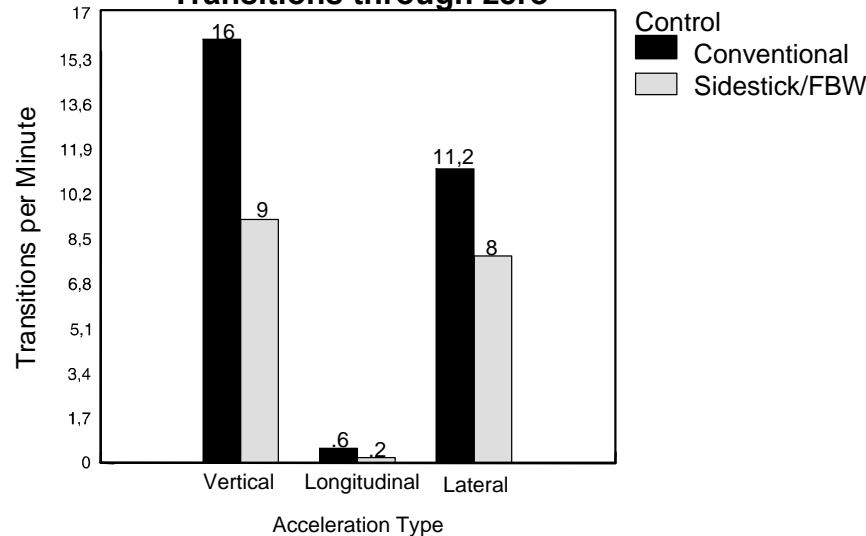

### Roll, pitch and yaw rates Transitions through zero

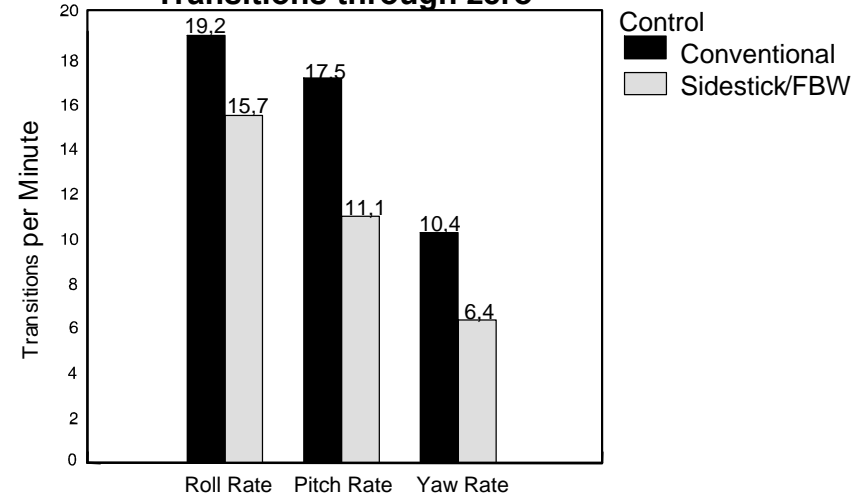

# Performance comparison : major results and conclusions

---

- All measurements of smoothness and stability favoured the sidestick by a large margin :
  - for roll and pitch angles and rates, standard deviations and rate through zero were reduced by 20% or more when flying with the sidestick,
  - accelerations in all three axes showed a large reduction in standard deviation and rate through zero when flying with the sidestick

# Performance comparison of sidestick/FWB and conventional controls

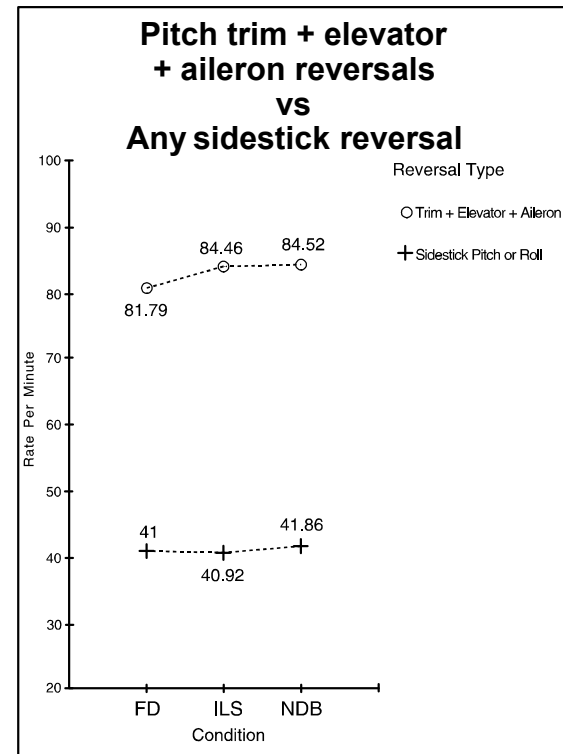
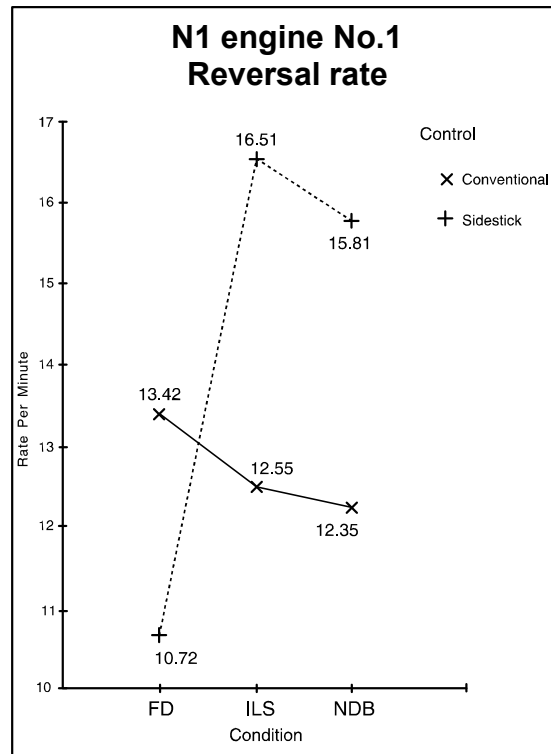
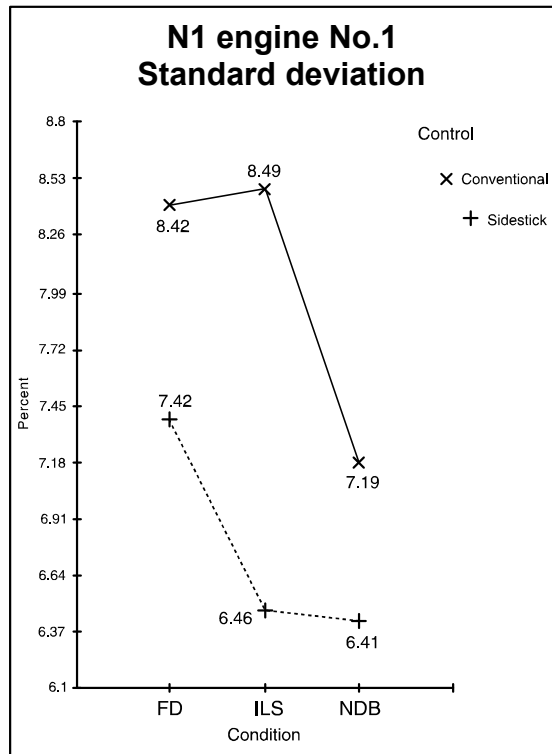

# Performance comparison : major results and conclusions

---

- All parameters related to fuel burn showed significantly better values with sidestick :
  - the sidestick/EFCS combination should improve fuel economy through unnecessary control surface movements and increased rear C.G. limits.
- Pilot control inputs were reduced by 50% or more and the system still achieved much better overall performance :
  - lower pilot workload should allow more time for dealing with emergencies and managing flight efficiency.

# A319/A320/A321 EFCS architecture

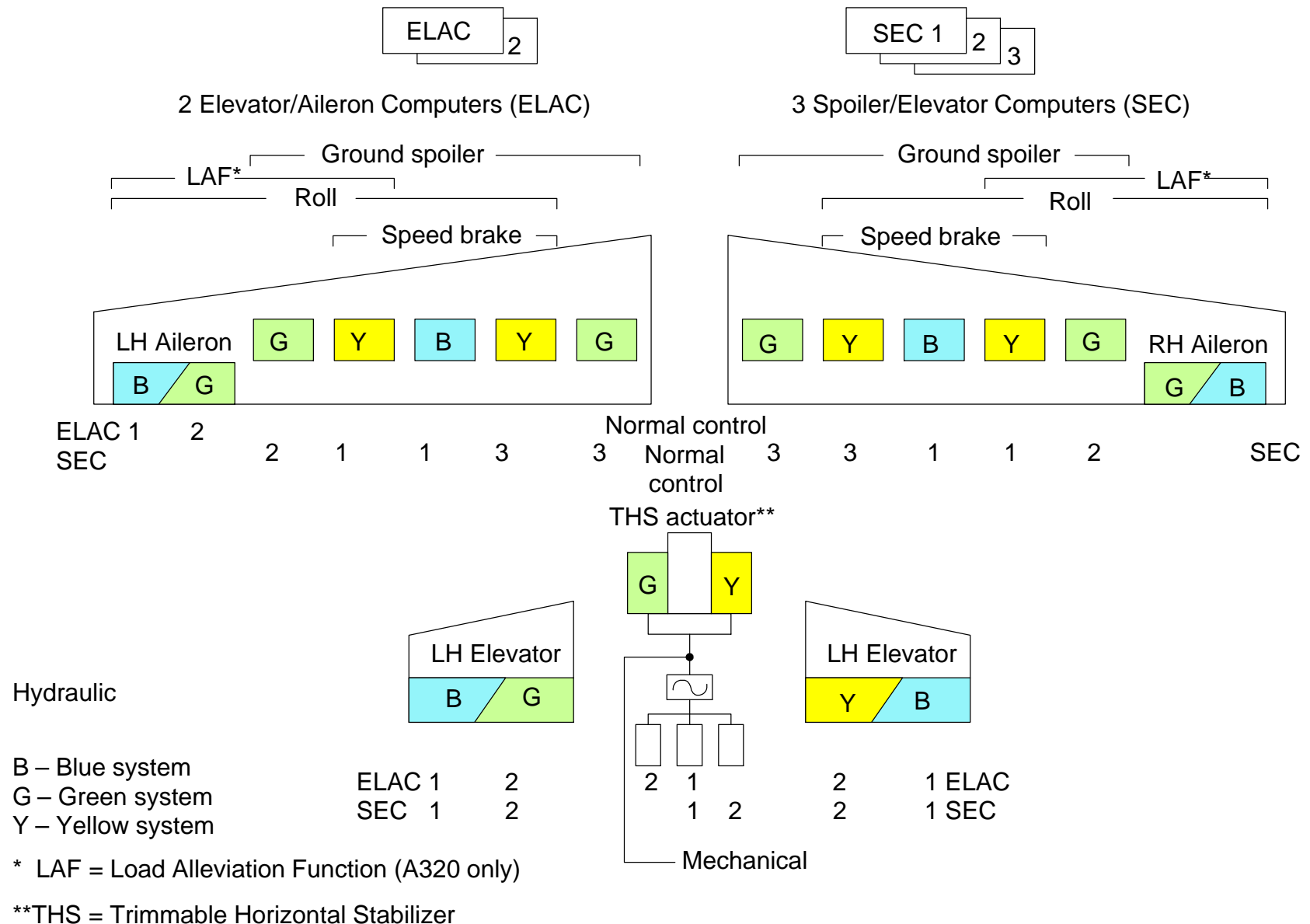

# A319/A320/A321 EFCS redundancy aspects

---

## Use of dissimilar redundancy

- Two types of computer
  - two ELACs to achieve aileron control and normal pitch control
  - three SECs to achieve spoiler control and standby pitch control
- No single type of  $\mu P$  :
  - ELAC - Motorola 68000
  - SEC - INTEL 80186
- Each ELAC and SEC is divided into two units :
  - one Control Unit (COM)
  - one Monitoring unit (MON)
- Four different softwares :
  - ELAC COM + MON
  - SEC COM + MON.
- Physical separation of hardware for COM and MON units.

In addition, **mechanical back-up** (through rudder and stabilizer control) will ensure adequate control in case of temporary loss of all electrical power sources including batteries.

# A319/A320/A321 EFCS electronic protections

---

## Self tests

- Each computer is able to detect its own failures :
  - processor test (check sum, watchdog...)
  - electrical supply monitoring
  - input and output test
  - wrap around of output to input.
  -
- Inputs are monitored :
  - by comparison of signals of the same type but sent by different sources
  - by checking the signal coherence.

## Other protections

- Specific routes are dedicated to :
  - control signals
  - monitoring signals
- Signals are linked :
  - ELAC 1 and SEC 1 computers on one side
  - ELAC 2, SEC 2 and SEC 3 computers on the other side.
- ELAC and SEC computers are qualified in convenience with DO 160 for electrical susceptibility test, the most severe category (Z) being applied.
  - Wires are installed in metal shields in the exposed areas.
  - For each signal, wires are twisted.
  - No signal grounding in the exposed areas.
  - Computer inputs and outputs connected to exposed wires are protected against the most severe spikes.
- This protection, combined with the precautions taken in the software, ensure good protection against lightning strikes and electromagnetic disturbances.



# A319/A320/A321 EFCS flight envelope protection

---

## Overspeed protection

- Positive load factor demand automatically applied when  $V_{mo} + 6kt$  or  $M_{mo} + 0.01$  is reached,
  -
- Speed limited to  $V_{mo} + 16kt$  and  $M_{mo} + 0.04$  when full nose-down stick is maintained,
- $V_{mo}/M_{mo}$  warning :
  - continuous repetitive chime
  - master warning light
  - overspeed red message on ECAM
  - red and black strip along the PFD scale.

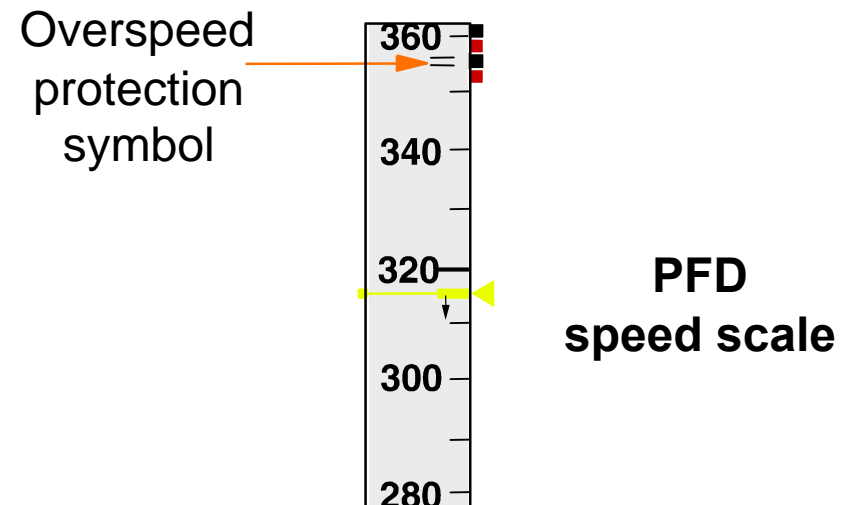

- Bank angle limitation to 45°

# A319/A320/A321 EFCS flight envelope protection

## ● AOA protection – principle

- When  $\alpha$  becomes greater than  $\alpha$  prot, the flight control normal law is replaced by an angle of attack law (angle of attack corresponds to stick displacement). Autotrim stops, resulting in a nose-down tendency.
- If  $\alpha$  reaches  $\alpha$  floor the auto-thrust system will apply go-around thrust.
- The  $\alpha$  max cannot be exceeded even if the stick is pulled fully back.
- At  $\alpha$  max + 4° an audio stall warning (cricket + synthetic voice) is provided.

## ● Consequences

- $\alpha$  prot is maintained if sidestick is left neutral
  - $\alpha$  max is maintained if sidestick is deflected fully aft
  - Return to normal law is obtained when sidestick is pushed forward.
- Amber strip on PFD indicates 1.13 Vs at take-off, or 1.23 Vs in other phases of flight.

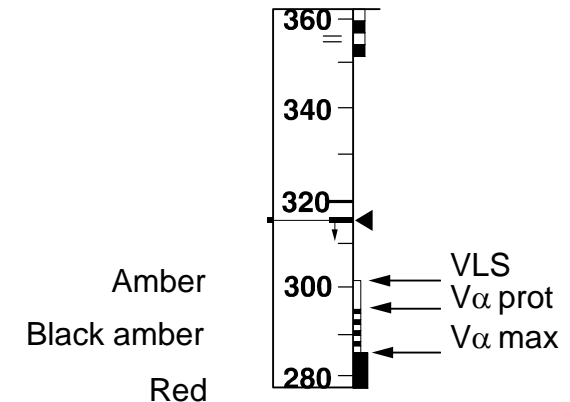
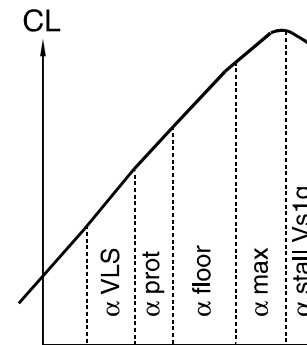

# A319/A320/A321 EFCS flight envelope protection

- **Manoeuvre protection**

The objective is to limit the load factor so as to allow the pilot to apply full sidestick deflection when high manoeuvrability is required.

Load factor limits : + 2.5g to 1g in clean configuration  
+ 2g to 0g flaps extended.

- **Attitude protection**

The objective is to complement AOA and high speed protection in extreme conditions and in windshear.

Bank is limited to : 33° stick released  
67° stick fully deflected.

Pitch is limited to : 30° nose up  
15° nose down.

If these limits are approached, the aircraft pitch and roll rate decrease and stop at the limit.

## Primary Flight Display

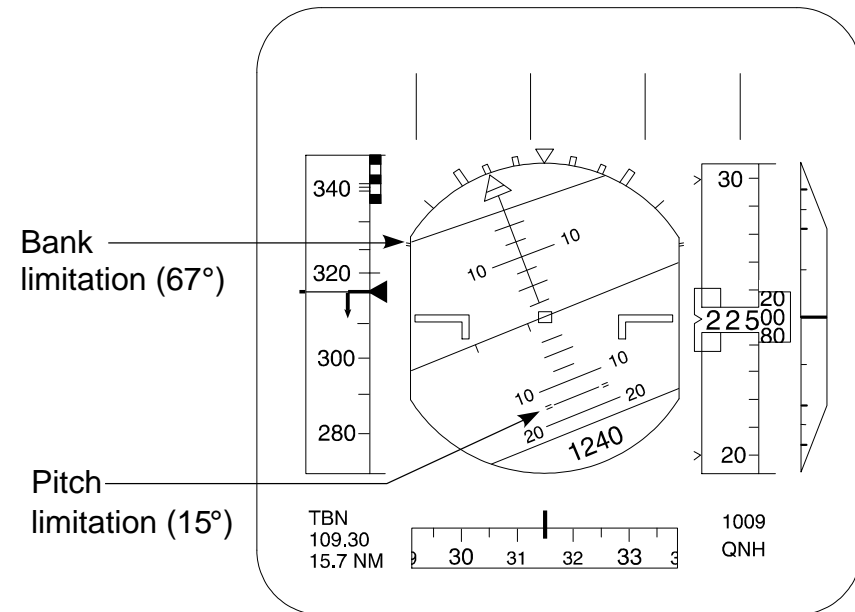



# **A319/A320/A321 EFCS flight envelope protection**

---

- **Windshear protection**

Windshear protection is ensured by :

- SRS more
- speed trend indication
- wind (speed and direction indication)
- flight path vector
- high angle of attack protection
- windshear warning (optional).

- **Low energy protection (basic on A321 and A319)**

- An audio warning “SPEED, SPEED, SPEED” is triggered to indicate to the crew that a thrust increase is necessary to recover a positive flight path angle through pitch control.

- **Load Alleviation Function (LAF) (only for A320)**

- The load alleviation function is used in conditions of turbulence in order to relieve wing structure loads
- The LAF becomes active at more than 0.3g in which case the ailerons and the spoilers 4 and 5 are deflected symmetrically upwards
- The LAF is no longer necessary for A321 and A319 which benefit from a reinforced structure.

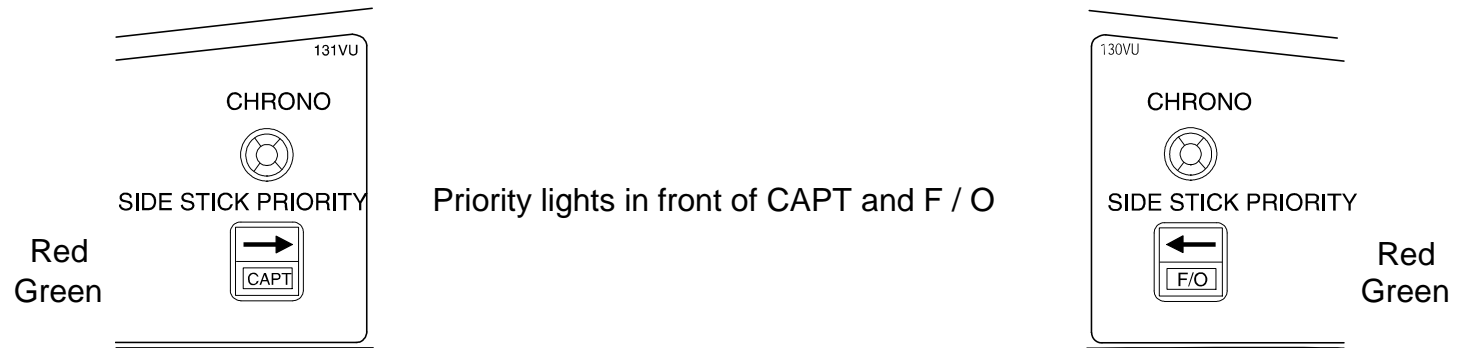

# A319/A320/A321 EFCS flight sidestick coupling/function

---

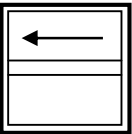
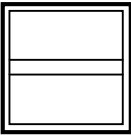
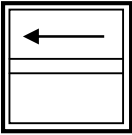
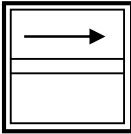

- Both sidesticks are coupled electronically to deal with :
  - simultaneous inputs
  - conflicts.
- Full control is obtained by pressing and keeping pressed the take-over button, thereby deactivating the other pilot's stick.
- After pressing the take-over button for more than 40 seconds, it can be released without losing priority.
- When both pilots press their take-over buttons, the last pilot to press will get the priority.
- onside priority can be maintained throughout by keeping the button pressed continuously for 40s.

# A319/A320/A321 EFCS sidestick priority display logic

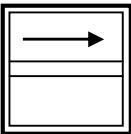
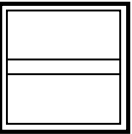
Captain's side		First Officer's side	
Sidestick	Annunciation	Annunciation	Sidestick
Take-over button depressed	 Green	Red 	Sidestick deflected
Take-over button depressed		Red 	Sidestick in neutral
Sidestick deflected	 Red	Green 	Take-over button depressed
Sidestick in neutral	 Red		Take-over button depressed

**Red arrow** in front of the pilot = loss of authority

**Green arrow** in front of the pilot = authority when opposite sidestick deflected

“PRIORITY RIGHT/LEFT” audio voice message when priority is taken.

# A319/A320/A321 EFCS speed brakes and ground spoilers

## ● Speed brakes

- Achieves by three surfaces
- When the sum of a roll order and a simultaneous speed brake order on either surface is greater than the maximum deflection achievable, the symmetrical surface is retracted until the difference between both corresponding surfaces is equal to the roll order.

- If engine power is above idle, an amber message is displayed on ECAM.

## ● Speedbrakes are automatically retracted when :

- selection of flaps configuration FULL for A320 and A319 (or 3 or FULL for A321)
- AOA protection is active

## ● Ground spoilers

- Preselection achieved :
  - with control handle in the armed position and idle thrust selected, or
  - by selecting reverse thrust
- Maximal extension (50°) of all surfaces then automatically achieved when wheels speed >72kt.

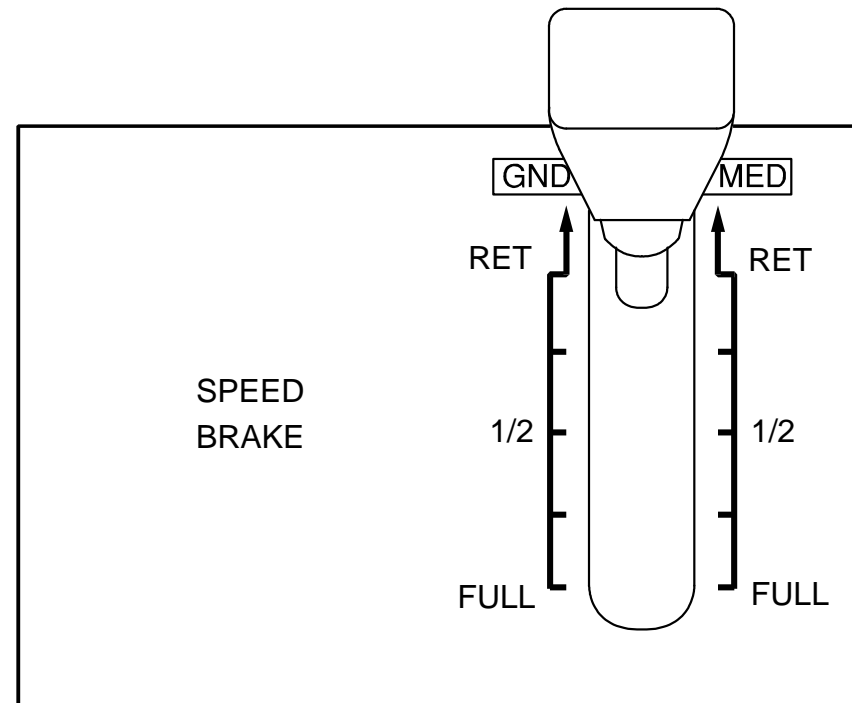



# A319/A320/A321 EFCS - flaps and slats control

- The flaps lever selects simultaneous operation of the slats and flaps.
- The five positions of the lever correspond to the following surfaces positions and flight phases :

Position	Slats	Flats	Flight phases	
0	0°	0°		Cruise / Hold
1	18°	0°		Hold / Approach
2	22°	10°	Take off	Approach
		15°(14°)		Approach / landing
3	22°	20° (21°)		
FULL	27°	35°(*) (25°)		Landing

(\*) : 40° for A320 with IAE engine or A319

() : setting for A321

- Computed by FACs, retraction speeds are presented on PFDs for :

- minimum flaps retraction or F -speed,
- minimum slats retraction or S -speed.

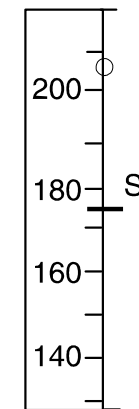
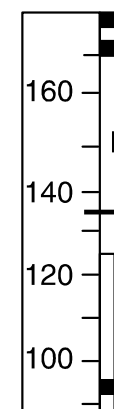
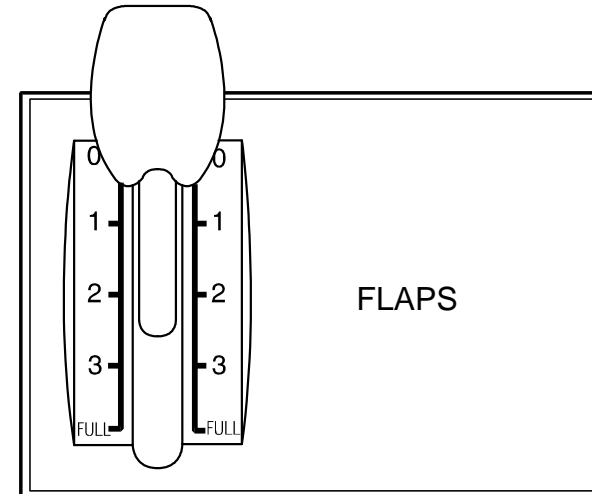

# A319/A320/A321 EFCS controls

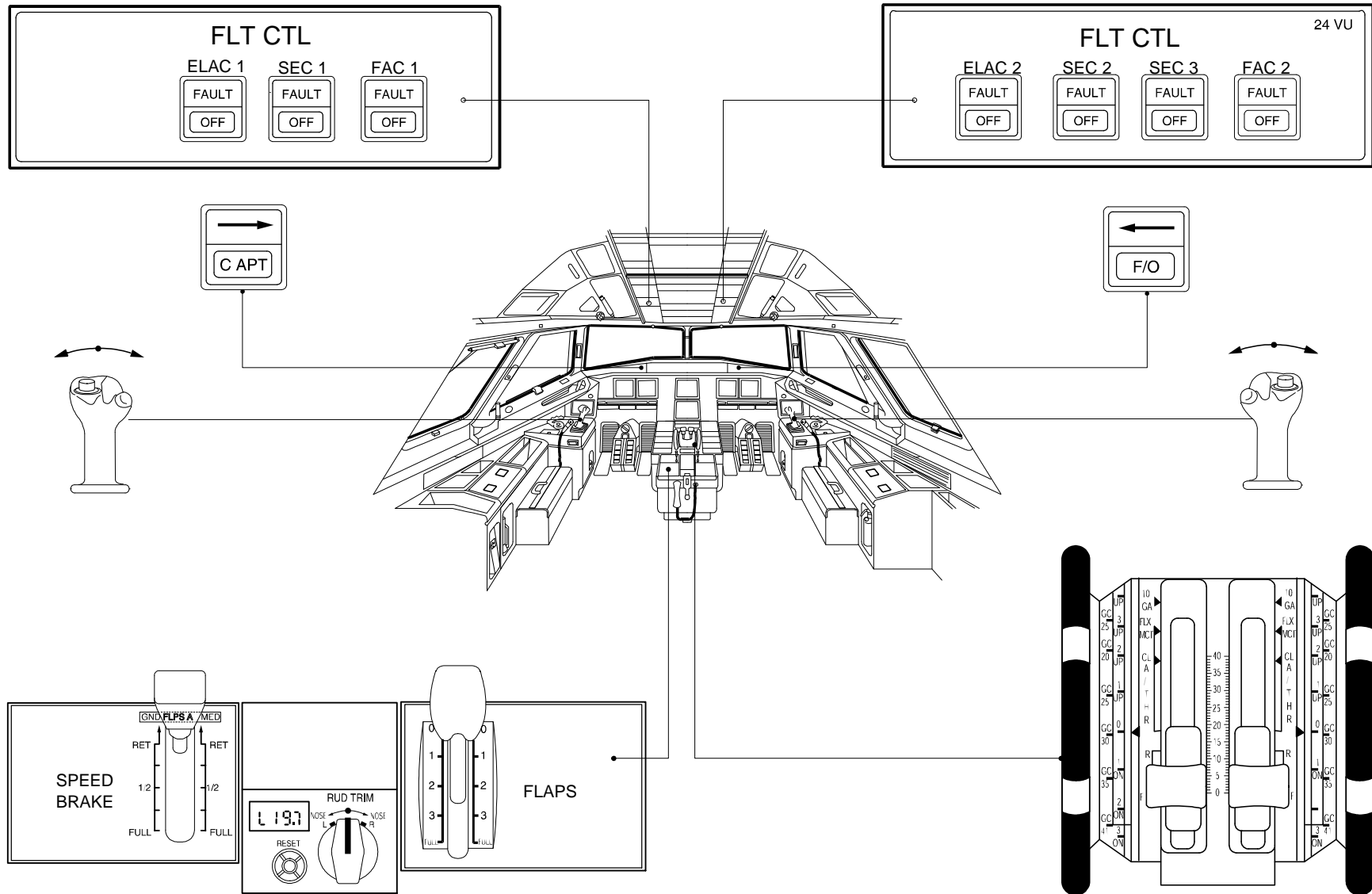

# A319/A320/A321 EFCS indications

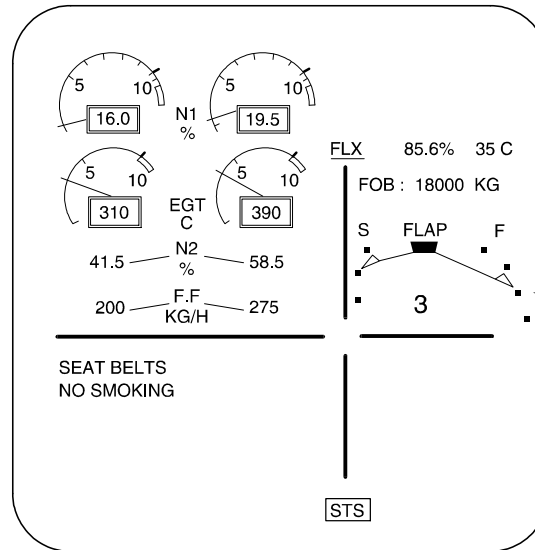

**ECAM upper display**

Slats/flaps indication

**ECAM lower display**

F / CTL page

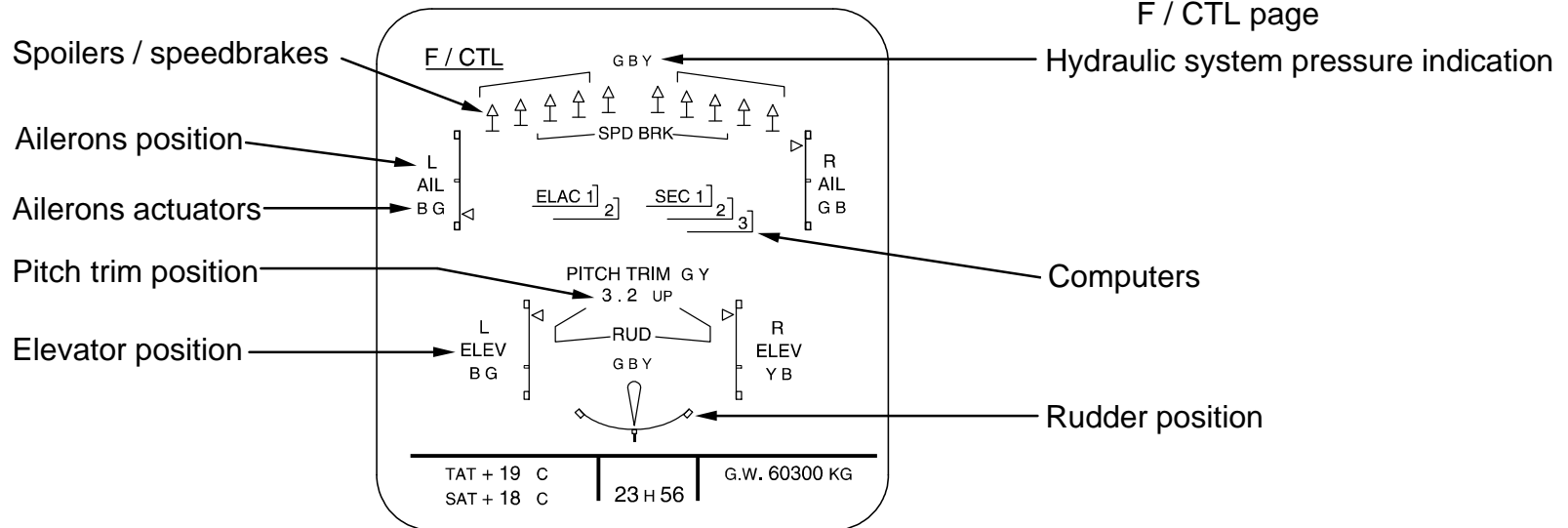

Spoilers / speedbrakes

Ailerons position

Ailerons actuators

Pitch trim position

Elevator position

Hydraulic system pressure indication

Computers

Rudder position





---

# 6. Landinggear



# A319/A320/A321 landing gear

---

## Main feature

- Conventional tricycle or bogie (option) landing gear and direct-action shock absorbers.
- Main gear retracts laterally and nose gear forward into the fuselage.
- Electrically controlled by two Landing Gear Control/Interface Units (**LGCIU**).
- Hydraulically actuated with alternative free-fall/spring downlock mode
- Alternating use of both LGCIUs for each retraction/extension cycle.
- In the event of one LGCIU failure, resetting the landing gear control lever results in transition to the other LGCIU.
- Elimination of gear lever neutral position through automatic depressurization of landing gear hydraulic supply above 260kt.
- Elimination of microswitches by use of trouble-free proximity detectors for position sensing.

## Braking system

The Braking and Steering Control Unit (**BSCU**) is a fully digital dual-channel computer controlling the following functions :

- normal braking system control
- anti-skid control (normal and alternate)
- auto brake function with LO, MED, MAX
- nosewheel steering command processing
- monitoring of all these functions

# A319/A320/A321 landing gear - braking system

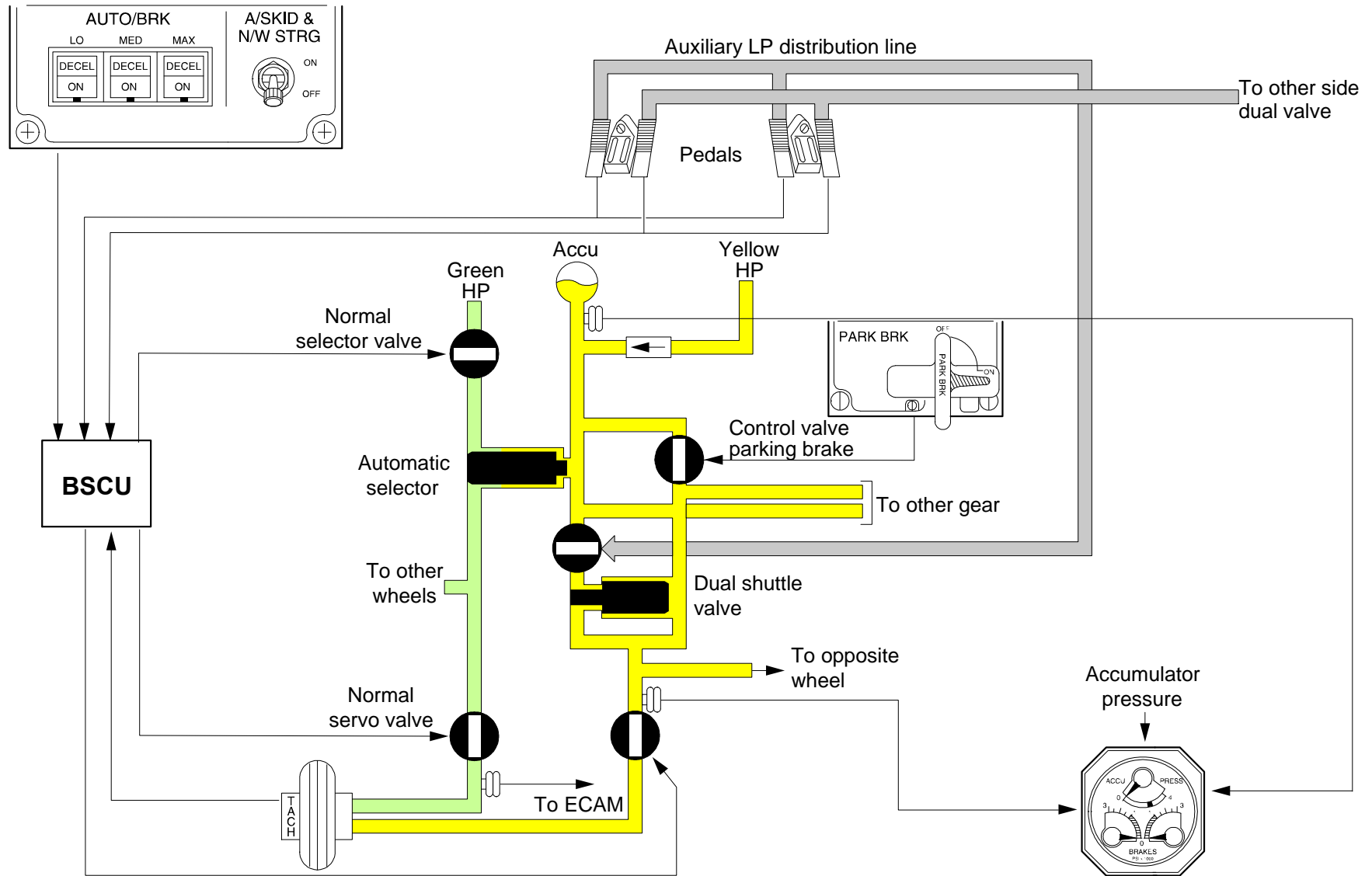



# A319/A320/A321 landing gear - braking system

---

- Carbon disk brakes are standard.
- Normal system (Green hydraulic system supply) :
  - electrically signalled through anti-skid valves
  - individual wheel anti-skid control
  - autobrake function
  - automatic switchover to alternate system in event of Green hydraulic supply failure.
- Alternate braking system (Yellow hydraulic system supply) :
  - hydraulically controlled through dual valve
  - individual wheel anti-skid control
  - no autobrake function.
- Emergency braking system (Yellow hydraulic system supply or Yellow brake power accumulator) :
  - hydraulically controlled by pedals with brake pressure indication on gauges
  - no anti-skid control
- Parking brake (Yellow hydraulic system supply or Yellow brake power accumulator) :
  - electrically signaled
  - hydraulically controlled with brake pressure indication on gauges.

# A319/A320/A321 landing gear – antiskid principle

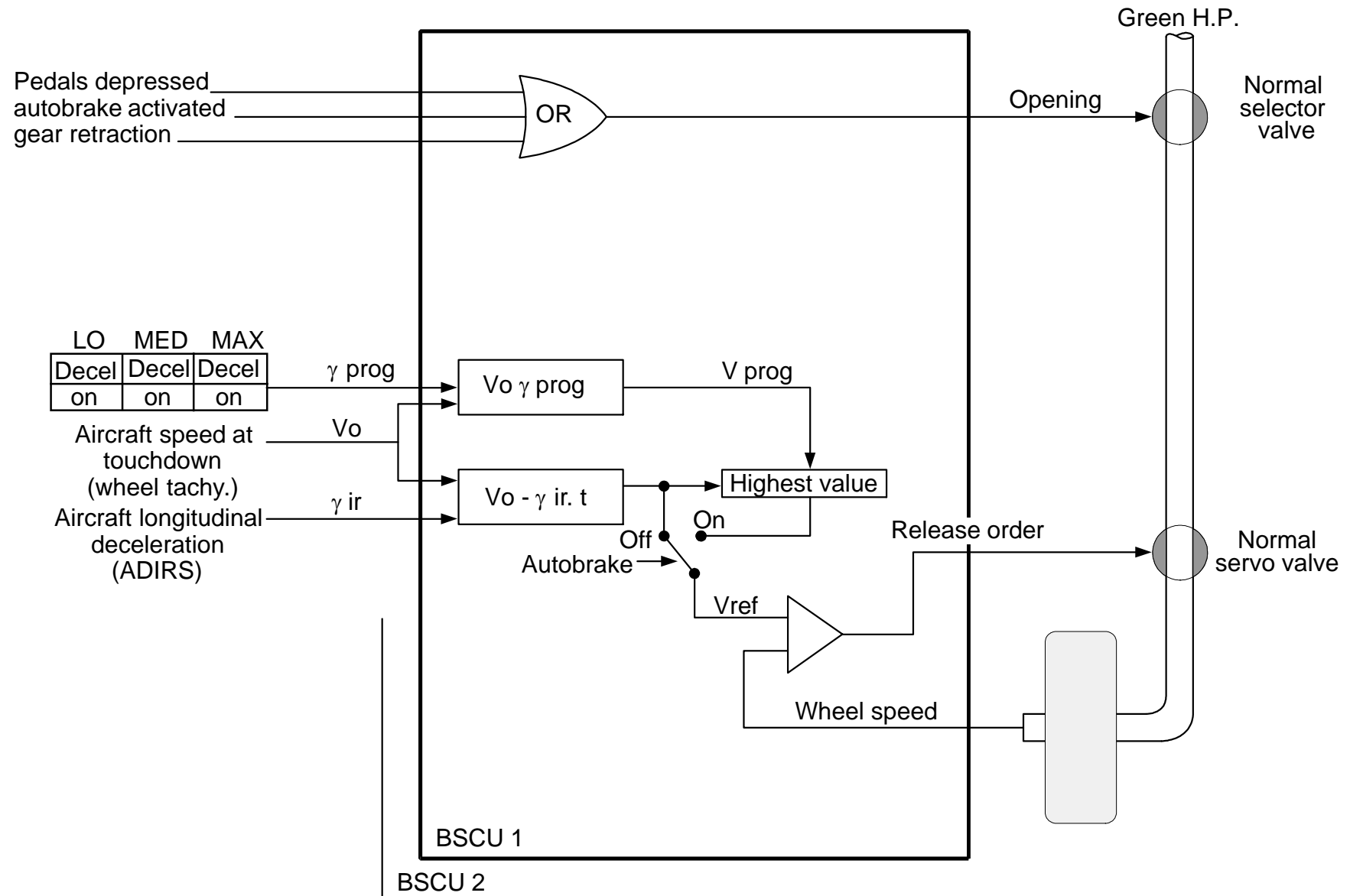

# **A319/A320/A321 landing gear braking principle**

---

## **Anti-skid system**

- From touchdown, aircraft speed is computed based on touchdown speed (wheels) and integrated deceleration (ADIRS). This reference speed is compared with each wheel speed to generate a release order for closing the normal servo valve in case of skid exceeding 13%.
- Brake pedals order results in opening this servovalve also modulated by anti-ski closing signals.

## **Autobrake system**

- From touchdown a specific speed is computed based on touchdown speed (wheels) and programmed deceleration (low, medium, max). This programmed speed is compared with each wheel speed to generate a release order for closing the normal servovalve to meet selected deceleration.
- If reference speed exceeds programmed speed (contaminated or iced runways) the former will take over for the anti-skid to modulate the normal servo valve.

# A319/A320/A321 landing gear - nose gear steering principle

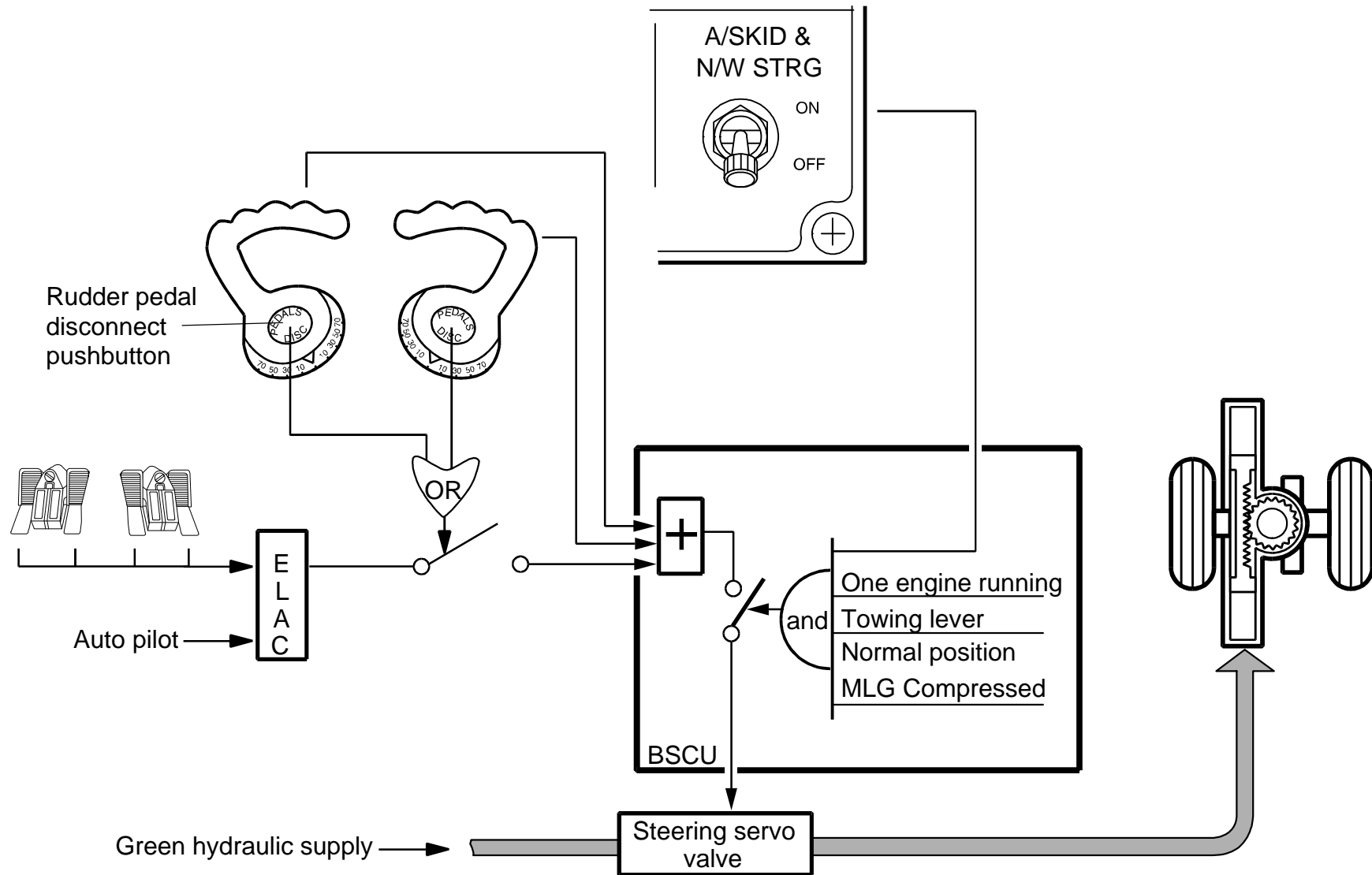

# A319/A320/A321 landing gear

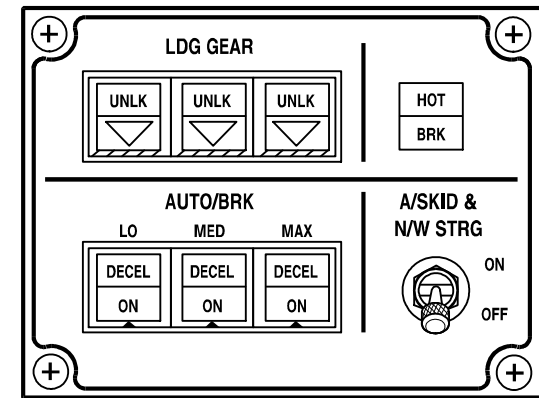
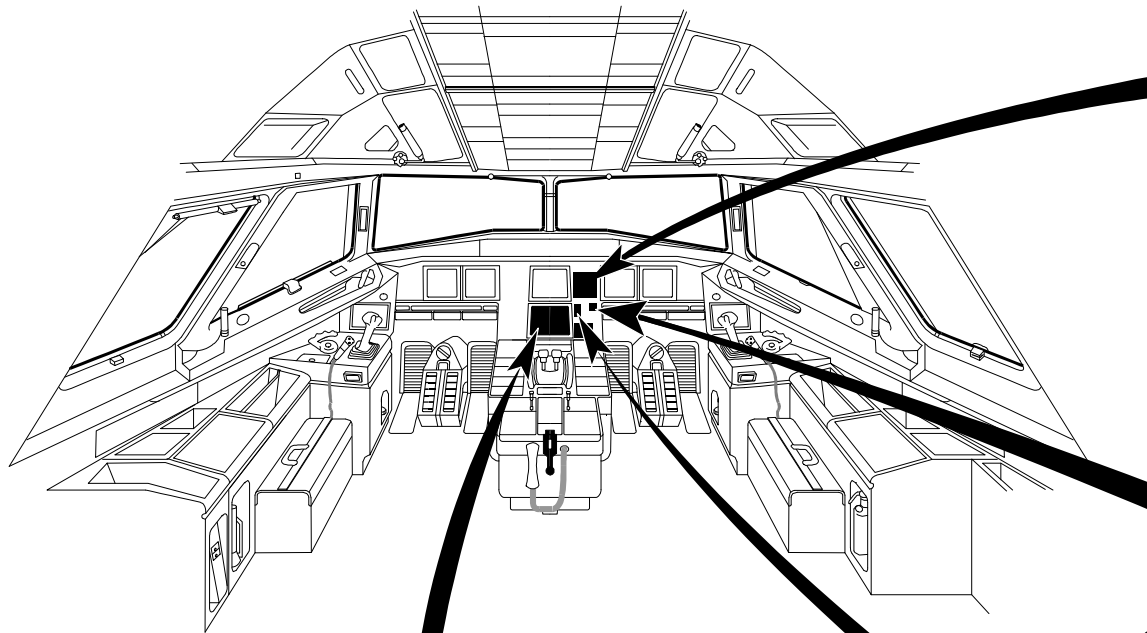

Autobrake panel and gear position indicator (System 1)

Tyre pressure psi (optional)

LDG door

Hottest brake

Anti-skid release indicator

Ground spoiler extension

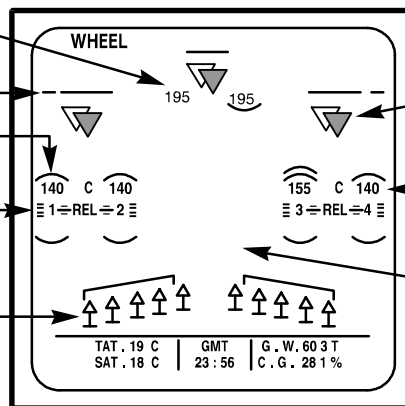

Gear downlock indication

Brake temp. °C

Autobrake indication

Wheel system page landing roll

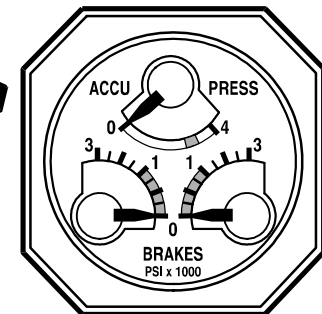
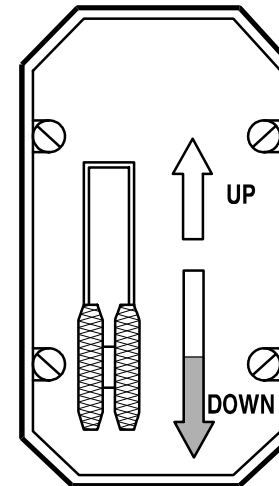

Brake pressure indication (alternate system)





---

# 7. Fuel system

# A319/A320/A321 fuel system - ventilation

### A319 / A320

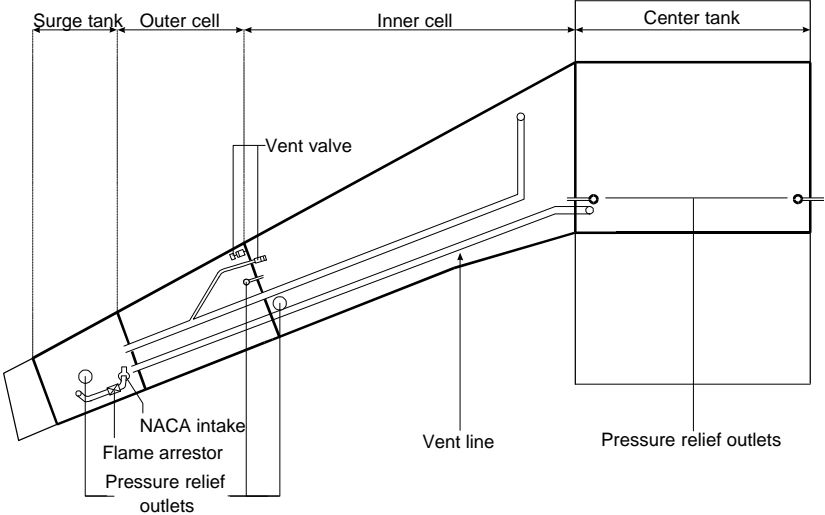

### A321

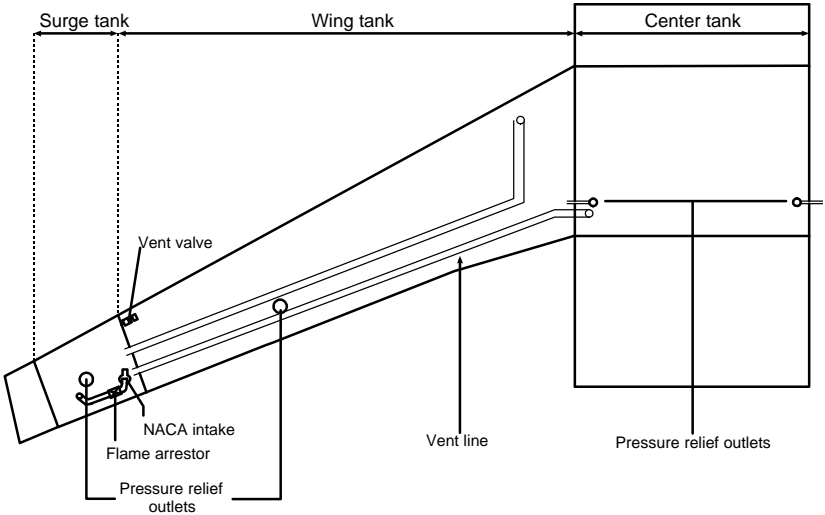



# A319/A320/A321 fuel system – basic layout

---

## ● Total fuel capacity

<b>A319 / A320</b>	
Two outer cells	1 760 litres (1 408kg)
Two inner cells	13 849 litres (11 079kg)
One center tank	8 250 litres (6 600kg)

<b>A321</b>	
Two wing tank	15 500 litres (12 400kg)
One center tank	8 200 litres ( 6 560kg)

(Weight calculated with a density of 0.8

An additional center tank (optional) increases the total fuel capacity by 2 900 litres (2 320kg).

On the A319 Corporate Jet, up to 6 additional center tanks can be added to increase the total fuel capacity by up to 17 000 litres.

An additional volume of 2% is available for expansion without spillage into the vent surge tank.

## ● Ventilation

- Each tank is separately ventilated via surge tanks at each wing tip.
- The center tank is ventilated via the LH surge tank.
- The surge tanks are opened to atmosphere via flame arrestors and NACA inlets.
- Vent valves ensure correct operation of the vent system.
- Pressure relief outlets protect the tanks from over- or under- pressure.

# A319/A320 fuel system – engine feed

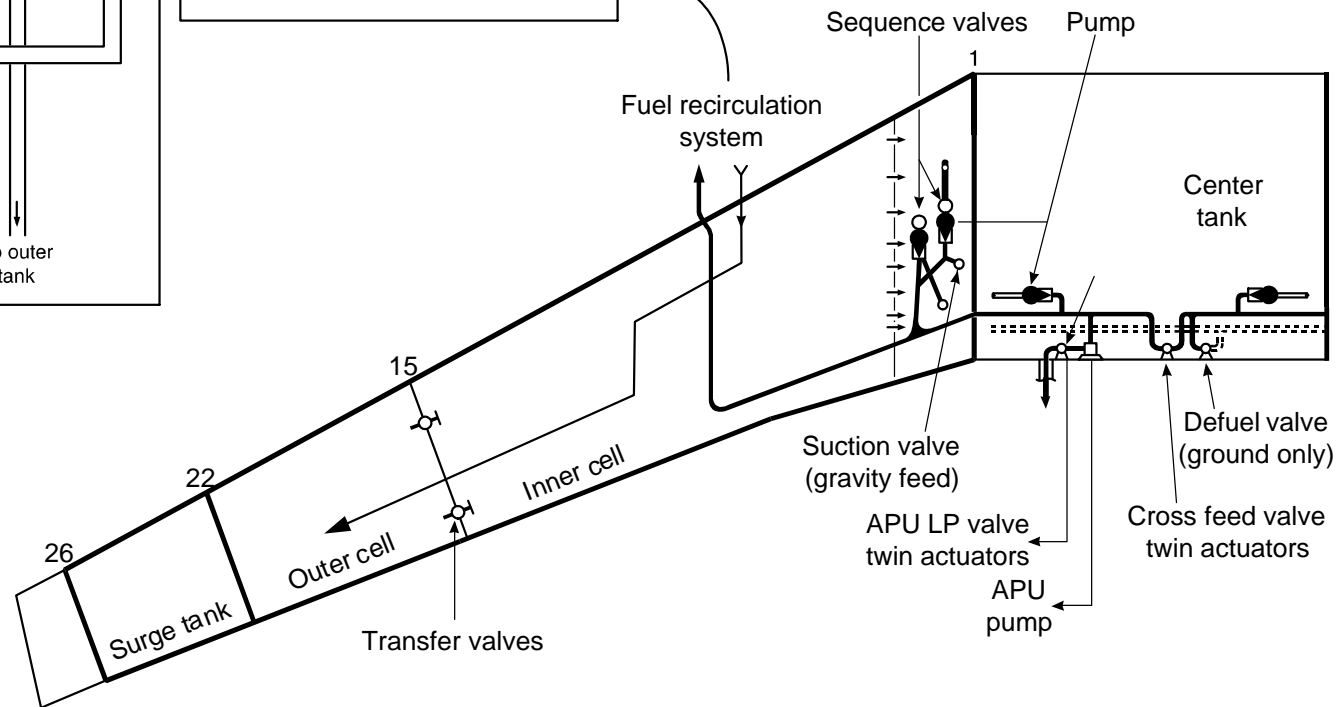
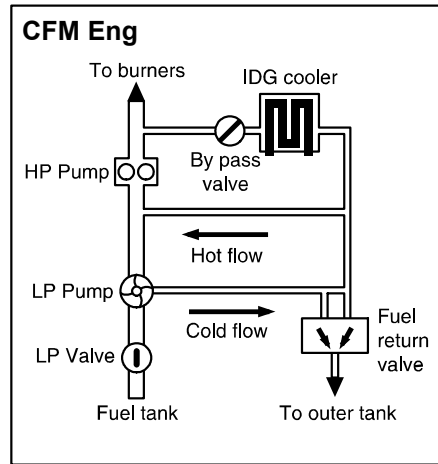
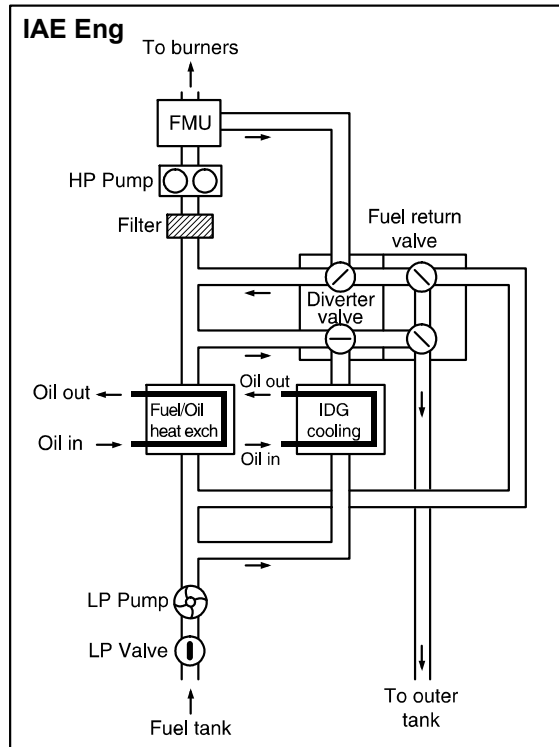

# A319/A320 fuel system – engine feed

---

## A319/A320 definition

- Fuel is delivered to the engines by means of booster pumps.
  - Each tank is equipped with two identical booster pumps.
  - Center tank feeds first, except during take-off and fuel recirculation when center tank pumps are switched off automatically.
  - Wing tank pumps operate permanently at a lower pressure than center tank pumps.
  - Thus, when center tank pumps stop, engine feed comes automatically from wing tank pumps.
  
- Two electrical transfer valves are installed on each wing.

They automatically open when the inner cell fuel reaches a low level (about 750kg) for fuel to drain from the outer to the inner cells.
  
- Fuel is recirculated automatically and transparently to the crew :

It ensures the IDG cooling (CFM and IAE eng.) and the engine oil cooling (IAE only) through a set of valves controlled by the FADEC.

# A321 fuel system – engine feed

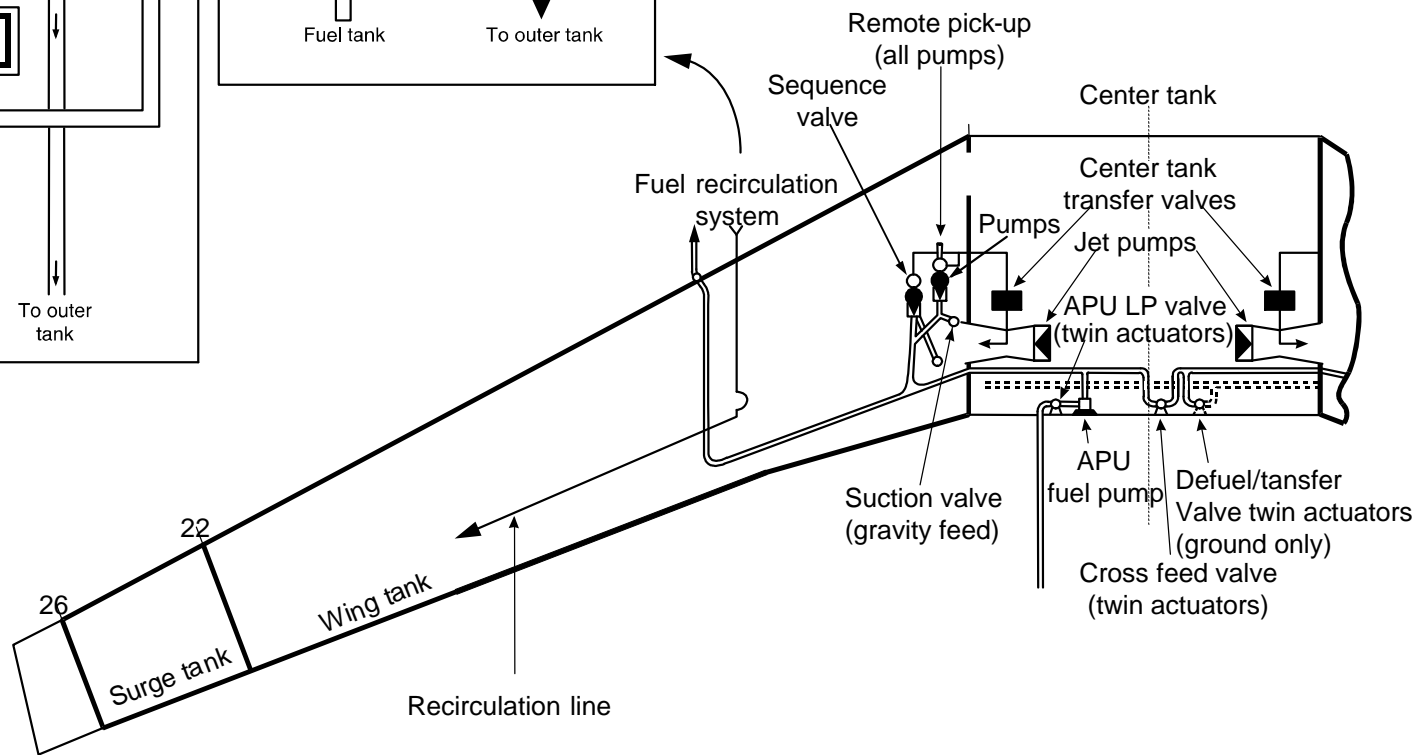
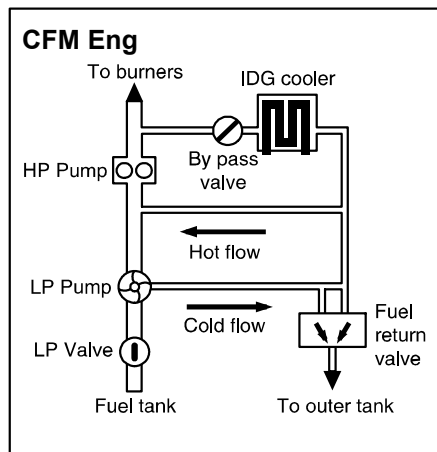
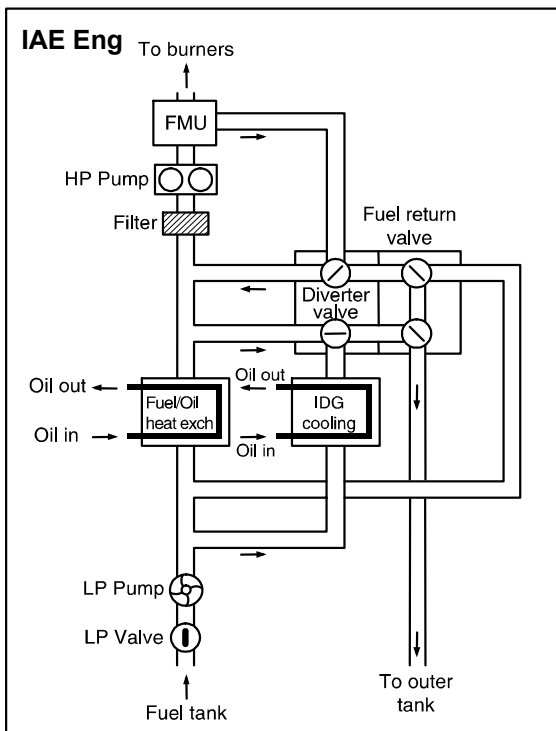

# A321 fuel system – engine feed

---

## **A321 definition**

The A321 fuel system has been simplified compared to the A319/A320 :

- Single wing tank in place of two cells wing tank, suppression of the outer/inner cell transfer valves.
- Center tank transfer to wing tank in place of center tank feed to engines :

When the transfer valves are open, fuel tapped from the wing pumps flows into the center tank jet pumps. It creates a depressurization which sucks the center tank fuel into the wing tanks

- a transfer valve automatically closes when the related wing tank is overfilled or when the center tank is empty.

The fuel recirculation principle is identical to A319/A320, the recirculated fuel being returned into the wing tank.

# A319/A320/A321 fuel system – control and indications

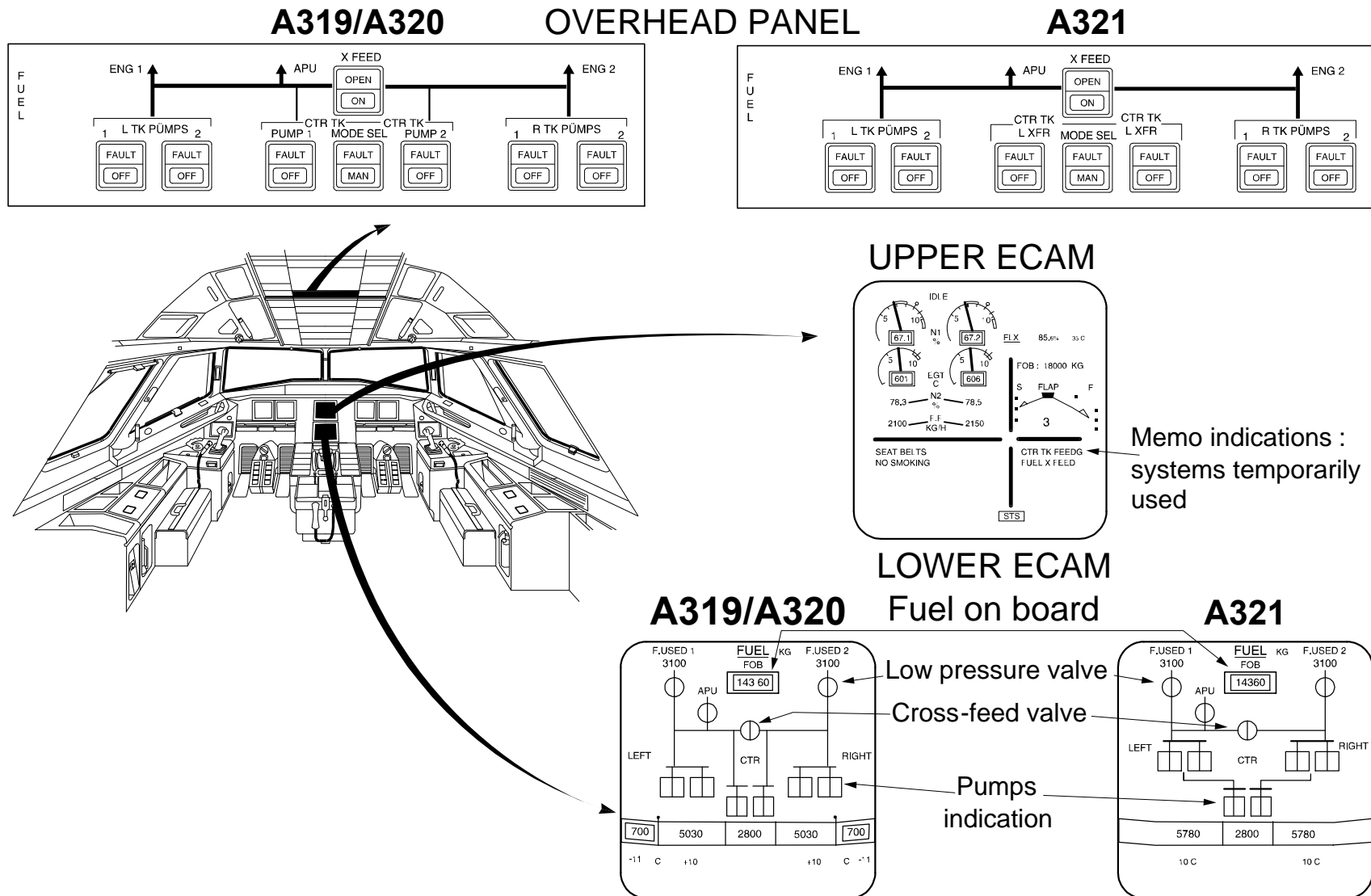

# **A319/A320A321 fuel system – control and indications**

---

- No crew action is required for normal operation.
- Indications :
  - fuel data (quantity, temperature) are available from a Fuel Quantity Indication (**FQI**) system
  - fuel quantity is permanently displayed on upper ECAM DU
  - fuel system synoptic on lower ECAM DU is displayed according to ECAM logic
  - low level warning is totally independent from FQI.
- Abnormal operations :
  - fuel feed sequence may be operated manually
  - one or both engines may be fed from any tank via cross-feed valve
  - gravity feed is possible from wing tanks.

# A319/A320A321 fuel system – refuel/defuel

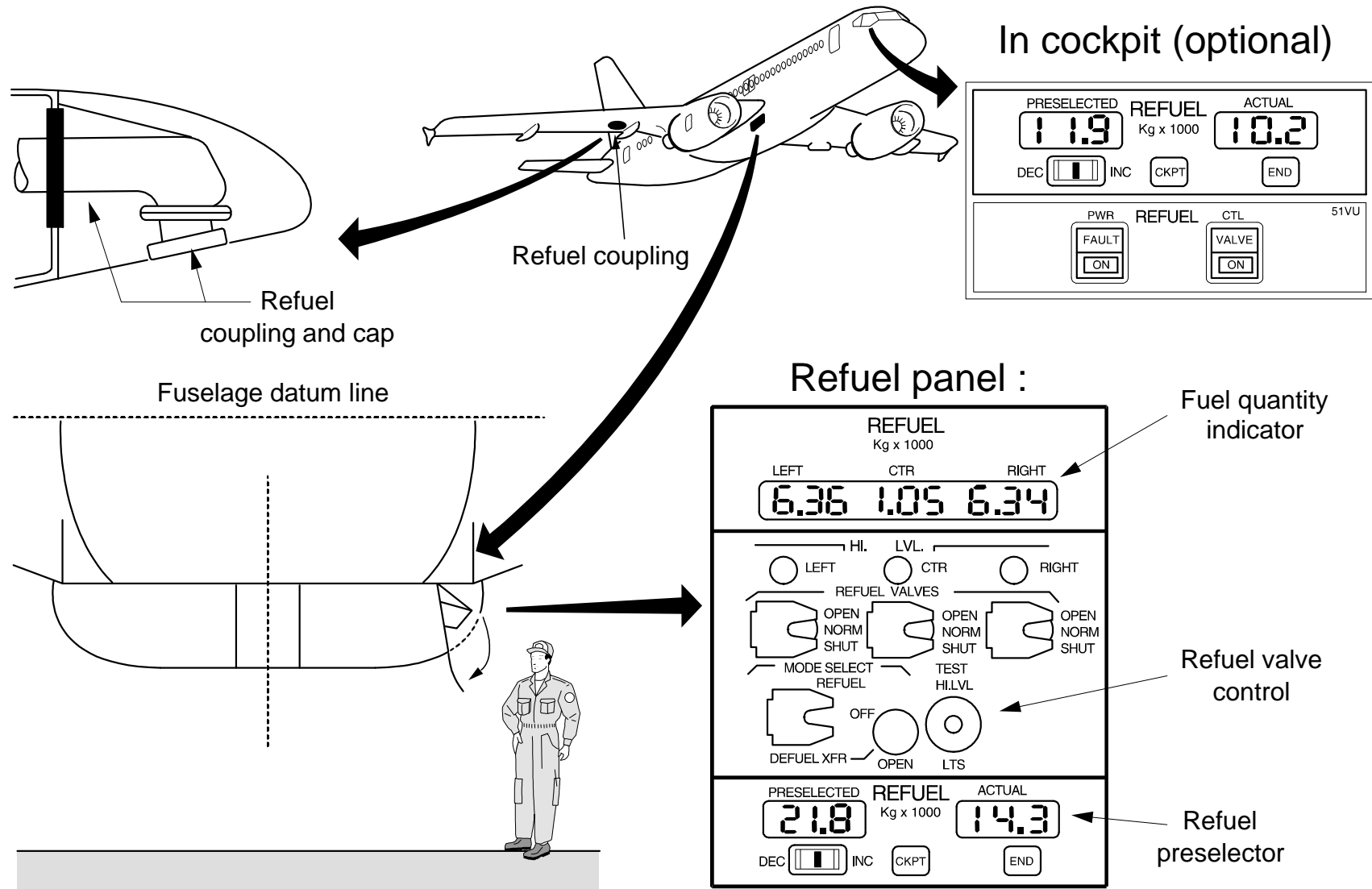



# A319/A320A321 fuel system – refuelling

---

- Refuel/defuel control is from an external panel located in the fuselage fairing under the RH wing within easy reach from the ground.
- One refuel/defuel coupling is located under the RH wing.
- Identical coupling on LH wing is available as an option.
- Refuelling is auto sequenced :

It starts with the outer cells (A319/A320) or the wing tanks (A321).

If the selected fuel quantity exceeds the wing tank capacity, the center tank is refuelled simultaneously.

- Refuelling time at nominal pressure is approximately 20 minutes for all tanks.
- Gravity refuelling can be achieved by overwing refuelling points.





---

# 8. Engine controls



# A319/A320/A321 engine controls - FADEC

---

- Thrust control is operated through Full Authority Digital Engine Control (**FADEC**) computers which :

- command the engines to provide the best suited power to each flight phase
- automatically provide all the associated protection required :
  - either in manual (thrust lever)
  - or in automatic (autothrust) with a fixed thrust lever.

- Engine performance and safety better than with current hydromechanical control system.

Simplification of engine/aircraft communication architecture.

Reduction of crew workload by means of automatic functions (starting, power management).

Ease of on-wing maintenance.

- The system design is fault-tolerant being fully duplicated, with “graceful degradation” for minor failures (i.e. sensor failures may lose functions but not the total system).

The engine shut-down rate resulting from FADEC failures will be at least as good as today’s latest hydromechanical systems with supervisory override.

- FADEC is an electronic system which incorporates a fully redundant Engine Control Unit (**ECU**) and an Engine Interface Unit (**EIU**).

Each engine is equipped with a FADEC which provide the following operational functions :

- gas generator control
- engine limit protection
- engine automatic starting
- power management
- engine data for cockpit indication
- engine condition parameters
- reverser control and feed back.

# A319/A320/A321 engine controls – FADEC architecture

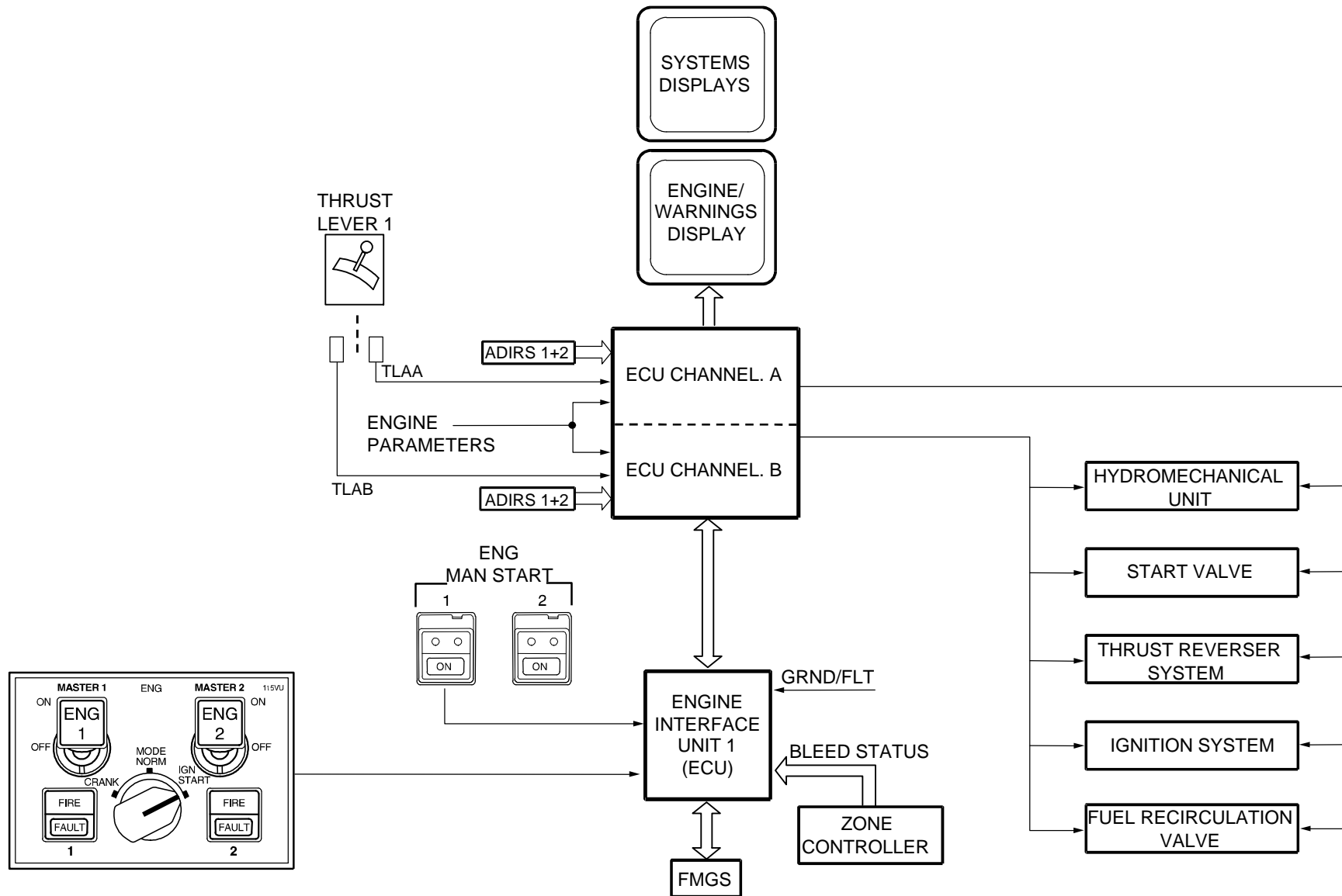

# A319/A320/A321 engine controls – ECU and EIU

---

One ECU located on the engine with dual redundant channels (active and standby) each having separate 28V DC aircraft power sources to ensure engine starting on ground and in flight.

In addition dedicated ECU alternator assures self power above 12% N2 for CFM56 (10% N2 for IAE V2500).

Dual redundancy for electrical input devices (ADIRS 1+2, TLAs, engine parameters).

Dual redundancy for electrical part of control actuator.

Simplex system for hydromechanical parts of the control.

Fault tolerance and fail operational capability.

High level of protection against electromagnetic disturbance.

The interface between the FADEC system and the other aircraft systems is mainly performed by the EIU through digital data buses.

One EIU per engine is located in the avionics bay.

Care is taken to preserve systems segregation for safety and integrity.

# A319/A320/A321 engine controls – CFM56

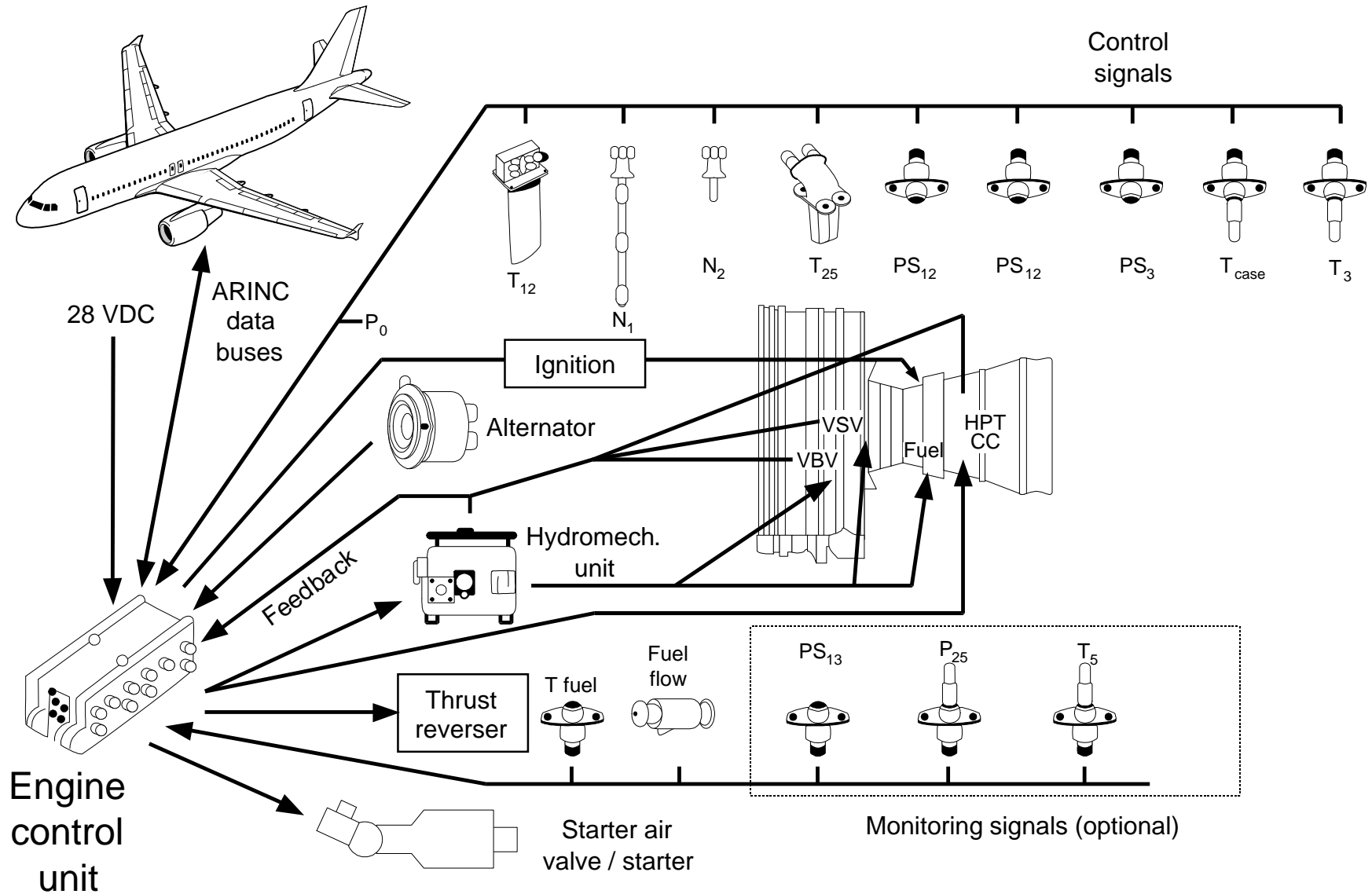



# A319/A320/A321 engine controls – V2500

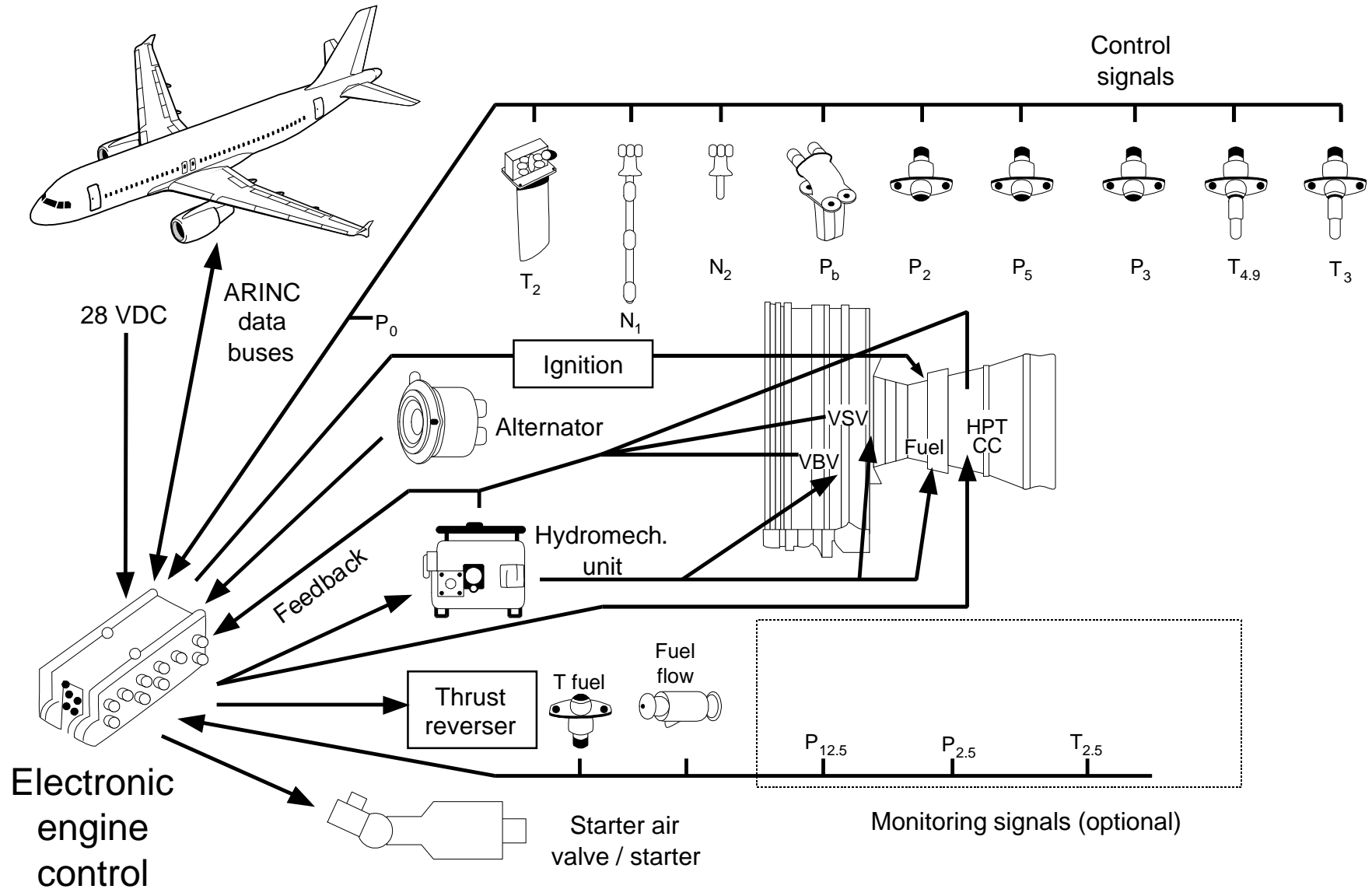

# A319/A320/A321 engine controls – thrust control schematic

## CFM56

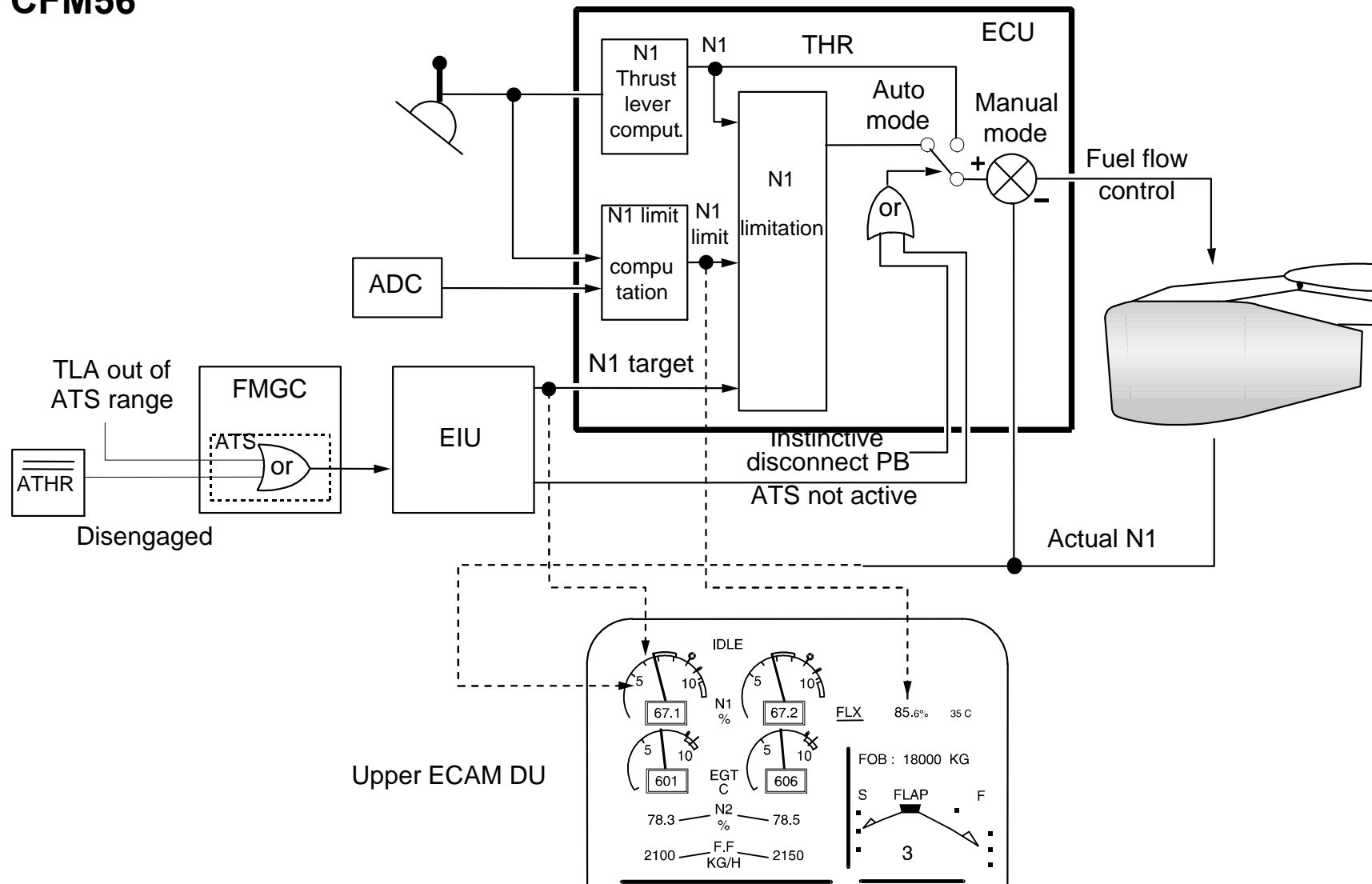

# A319/A320/A321 engine controls – thrust control schematic

IAE V2500

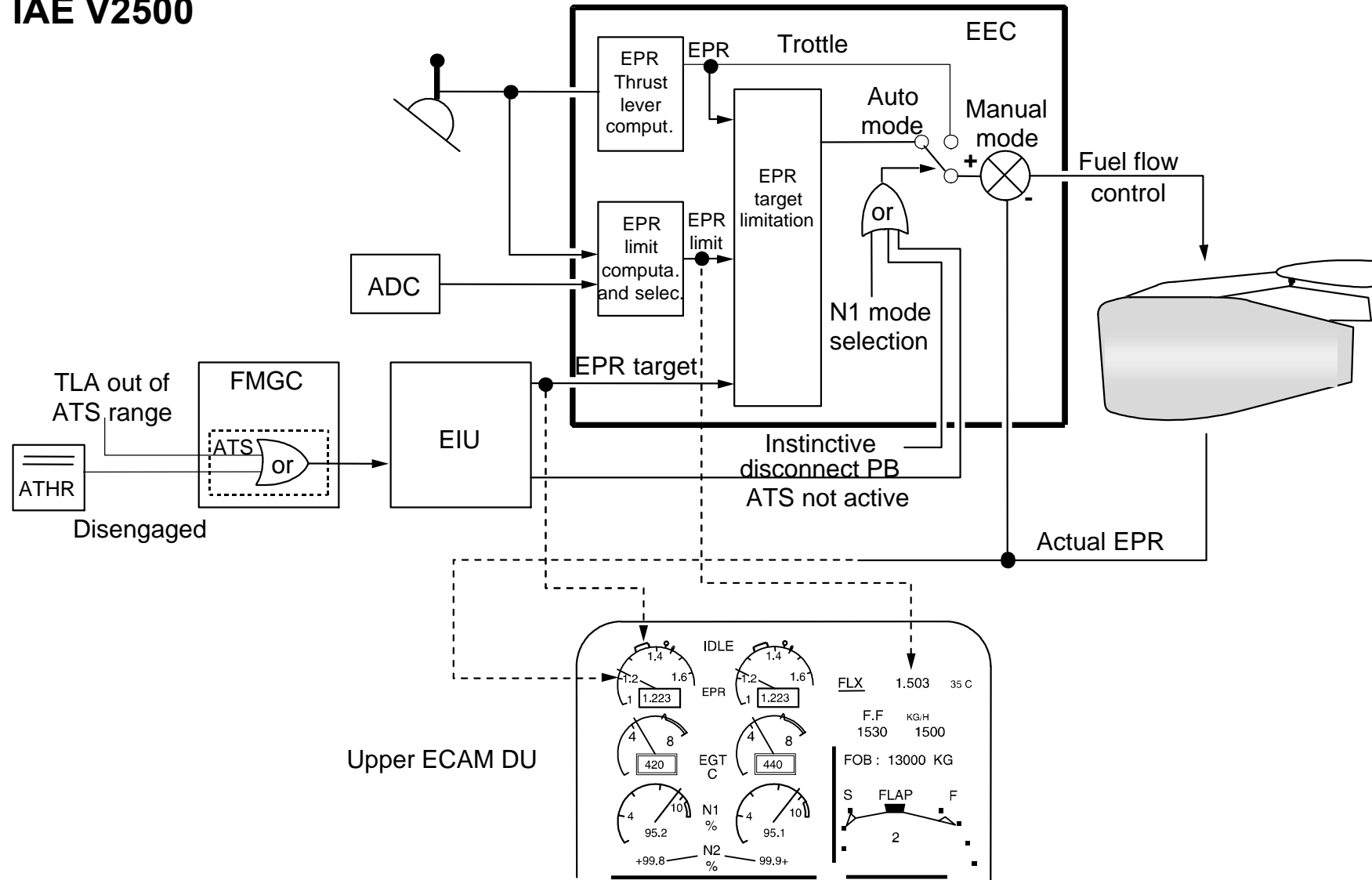



# A319/A320/A321 engine controls – thrust control operations

Limited thrust parameters (N1 for CFM56, EPR for V2500) computed by FADEC.

Selection of thrust limit mode obtained directly by throttle position :  
Six positions defined by detents or stops.

Thrust lever only to be moved manually (no servomotor) : lever position not necessarily representing engine thrust delivered

According to the thrust lever position the FADEC computes :

- Thrust rating limit (no TRP)
- N1 (EPR) when in manual mode
- N1 (EPR) which can be achieved in

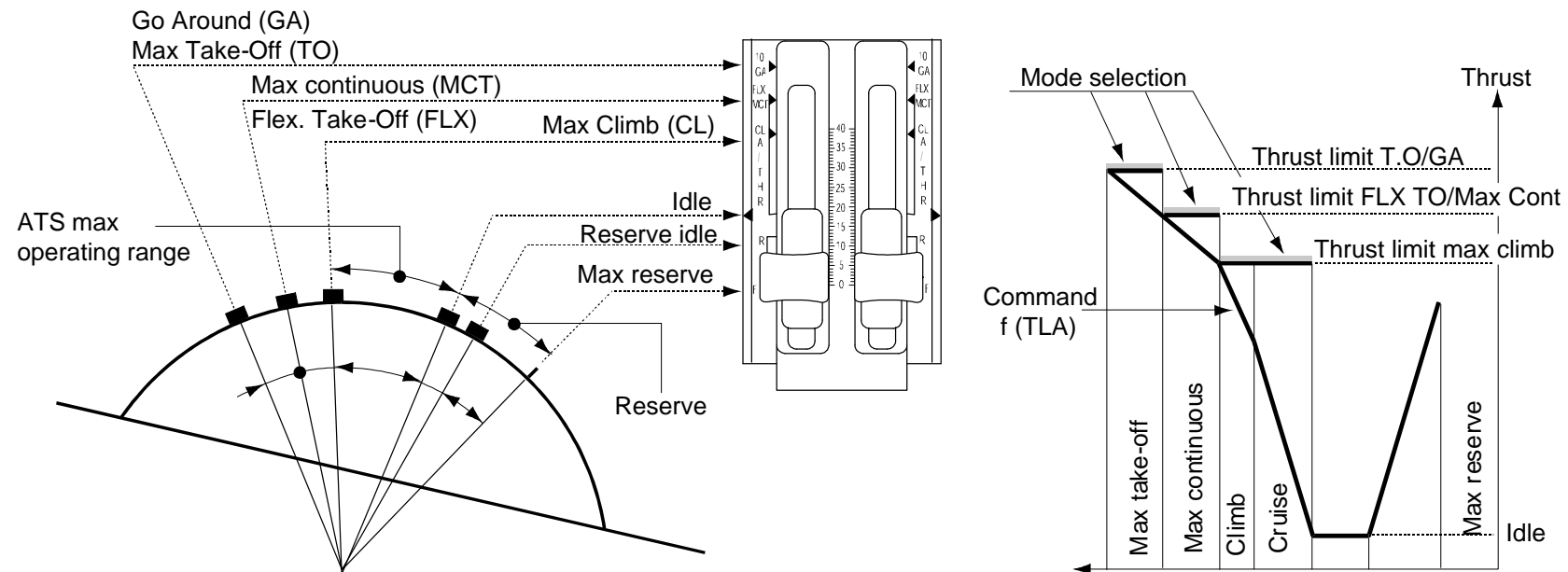



# A319/A320/A321 engine controls indications (CFM56) on ECAM upper DU

---

Appears when both engines at IDLE (\*)

Transient N1 during ATS operation corresponding to FMGC demand to go to N1 target

Symbol corresponding to the thrust lever position

Max N 1

N1 actual

Max permissible N1

IDLE

Flex temperature (entered through MCDU)

Exhaust gas temperature

N 1 rating limit

S

F

FLX

**3**

SEAT BELTS  
NO SMOKING

FOB : 18000 KG

Thrust limit mode

\* Basic on A319/A321



# A319/A320/A321 engine controls indications (IAE 2500) on ECAM upper DU

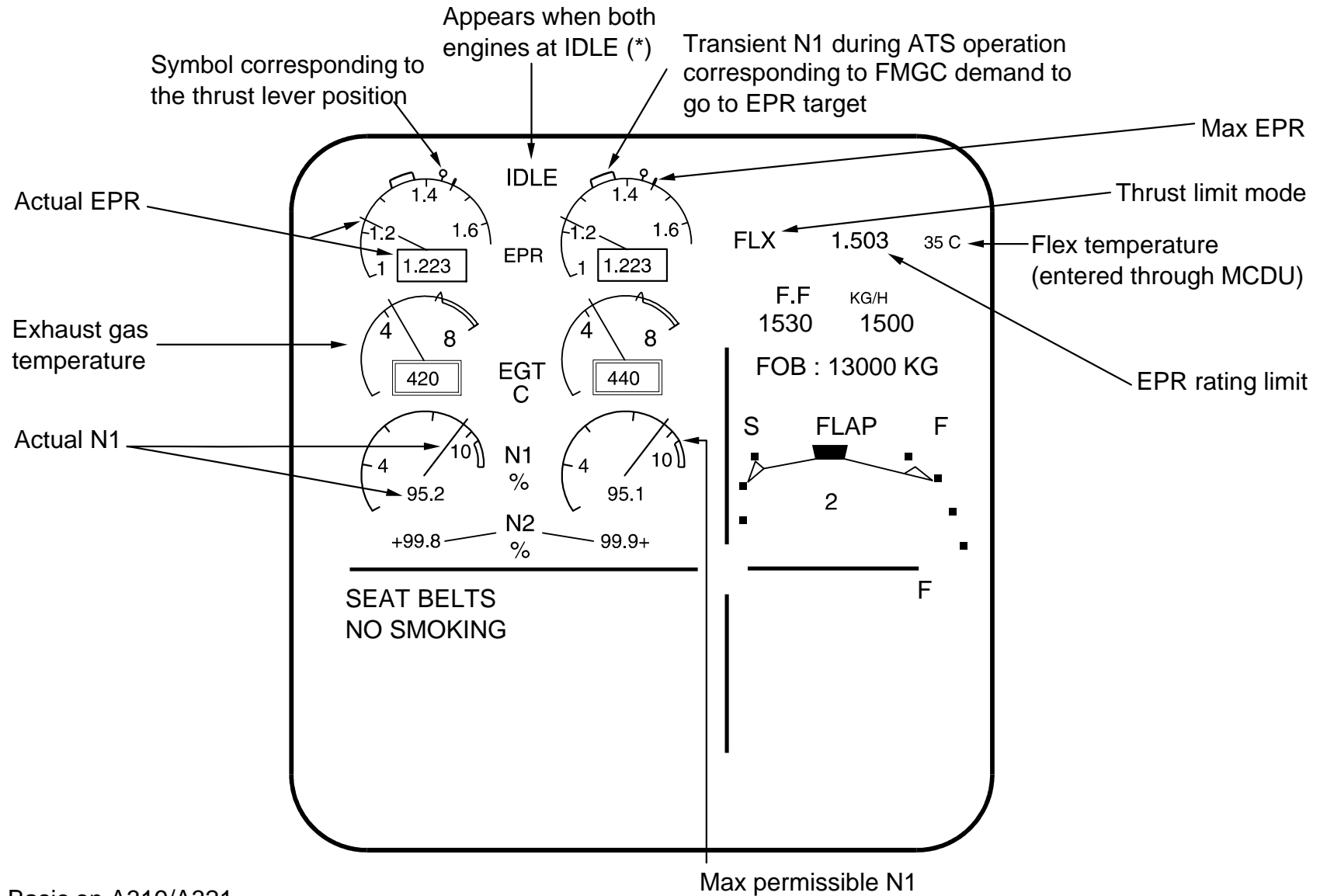

\* Basic on A319/A321

# A319/A320/A321 EIS independent : after “clear” action

## Start configuration

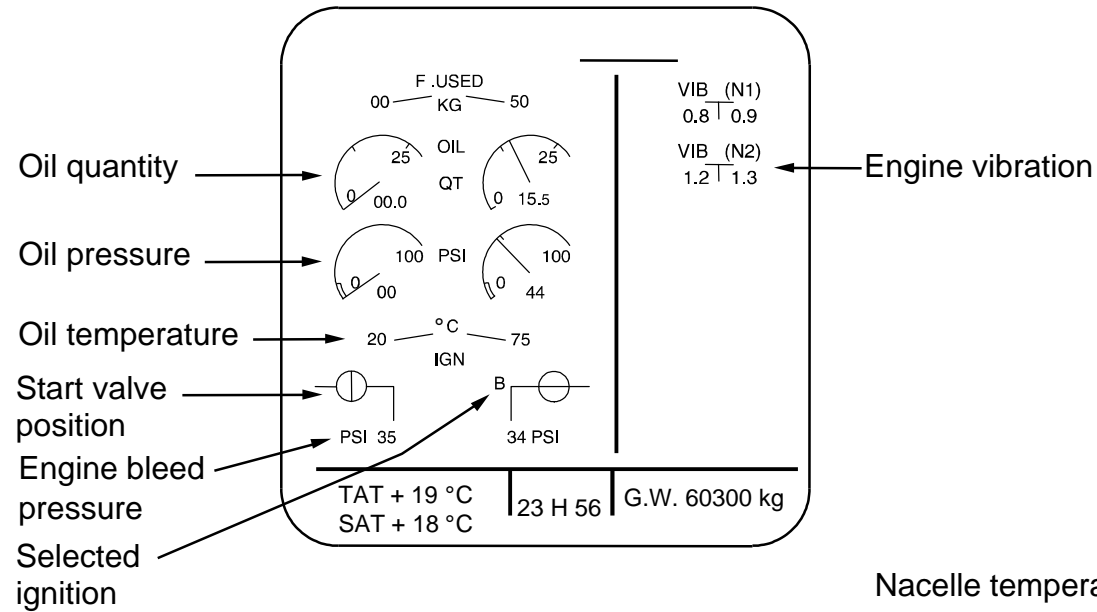

## After start configuration

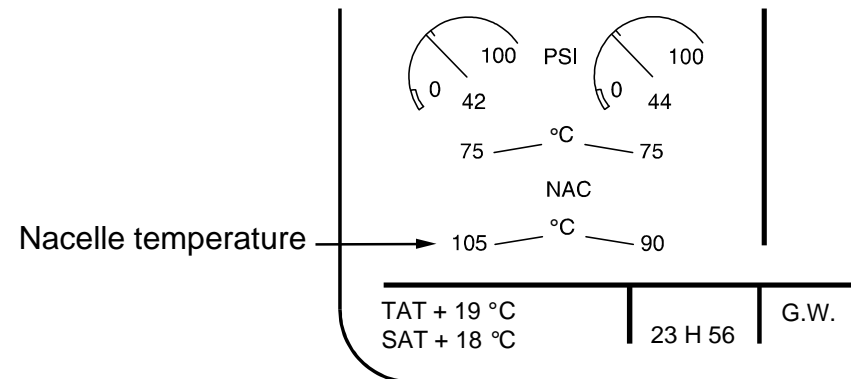



# A319/A320/A321 engine controls indications on PFD : FMA

The following indications may appear on the PFD Flight Mode Annunciator (FMA), in upper left corner :

- ASYM : Only one thrust lever is set to CLB or MCT position,
- CLB : Flashing when aircraft above thrust reduction altitude and thrust levers not in CLB notch,
- MCT : Flashing in case of engine failure if the non-affected thrust lever is not set at MCT,
- A-FLOOR :  $\alpha$  -floor condition encountered,
- TOGA LK : When leaving  $\alpha$  -floor condition and thrust still at MTO

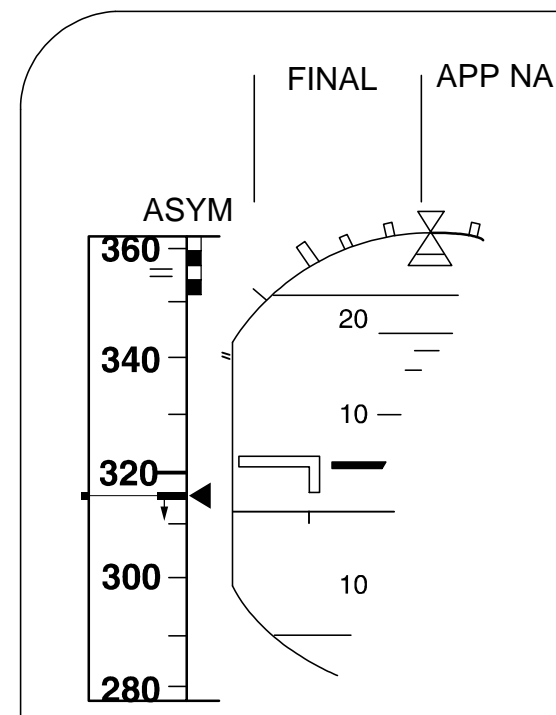



# **A319/A320/A321 engine controls - thrust reverse**

---

Reverser deployment selection by positioning thrust lever into reverse area and by acting on independent locking levers.

Thrust lever position below rev. idle modulates reverse power.

Automatic engine idle setting in case of reverser malfunction.

Automatic max. reverse power limitation versus ambient conditions with full rearward thrust lever position.

Display of reverser status on ECAM upper DU.

# A319/A320/A321 engine controls - start procedure

CFM

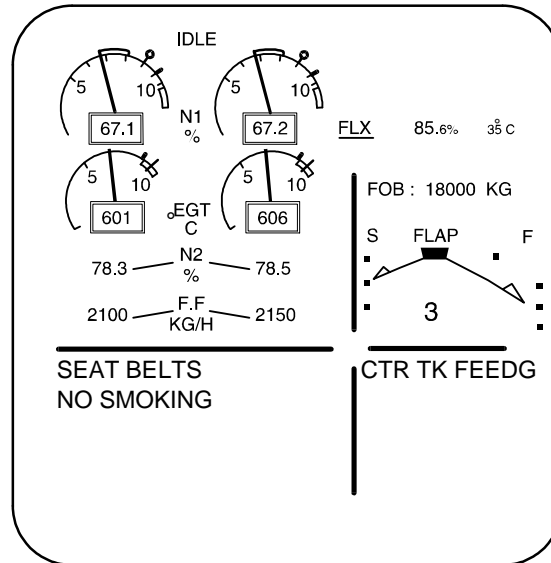

Upper ECAM DU

IAE

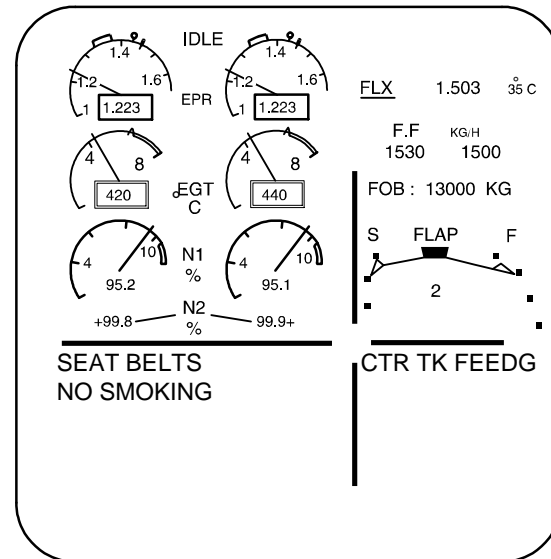

Lower ECAM DU

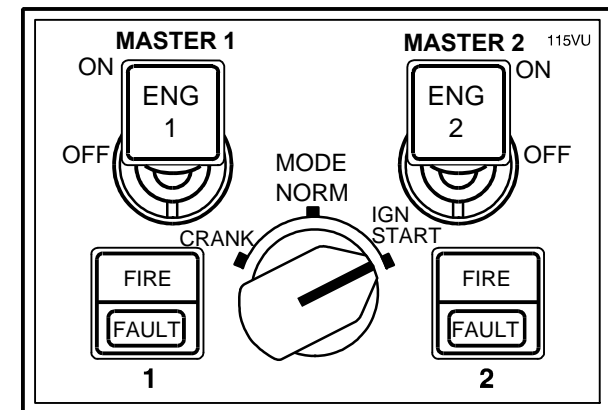
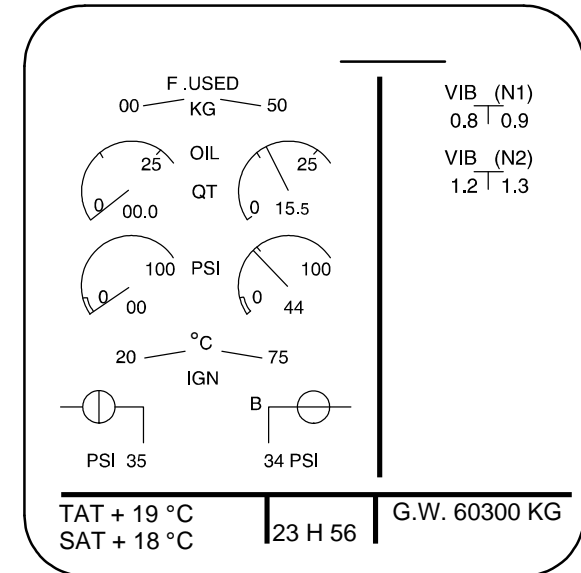

# **A319/A320/A321 engine controls - start procedure**

---

- Engine mode selection ..... IGN/START

ECAM ENG page is automatically displayed on lower ECAM.

- Pack valves close (CFM engines)

- MASTER switch ..... ON

- Start valve opens
- APU RPM increases
- N2 increases
- Oil pressure increases
- Pack valves close (IAE engines)

Depending on N2 values reached :

- Ignition starts
- HP fuel valve opens

When sufficient N2 value is reached :

- Start valve closes, ignition stops, APU RPM returns to normal, pack valve reopens.

- Main and secondary parameters ..... CHECK NORMAL

## **For abnormal conditions on ground :**

FADEC automatically controls :

- Start abort in case of hot start, hung start or no light up.
- Automatic engine crank after :
  - first start abort for IAE
  - any additional start attempts for CFM.





---

## 9. Auxiliary power unit

# A319/A320/A321 APU – controls and display

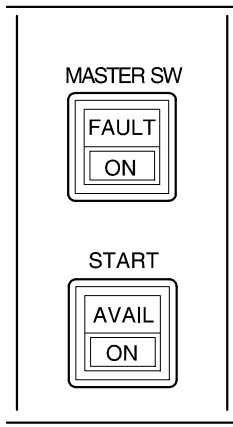

**Overhead panel**

**External panel (on nosewheel)**

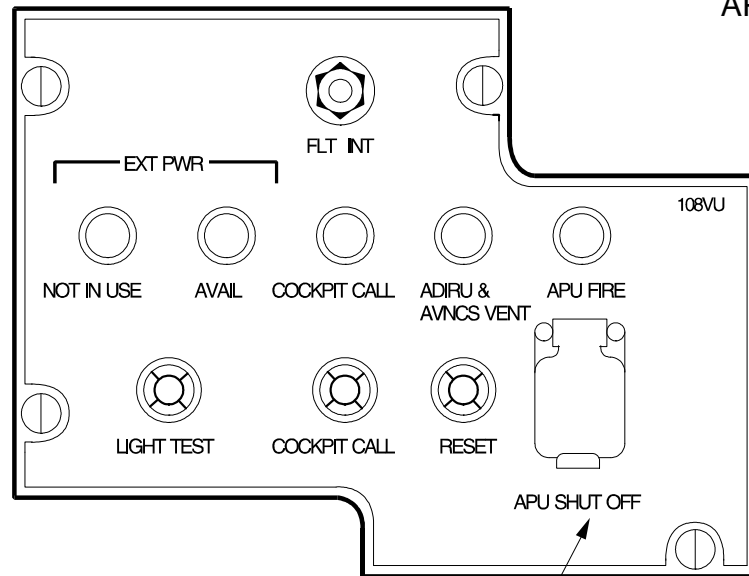

**APU shut-off push-button**

**ECAM lower display :  
APU system page**

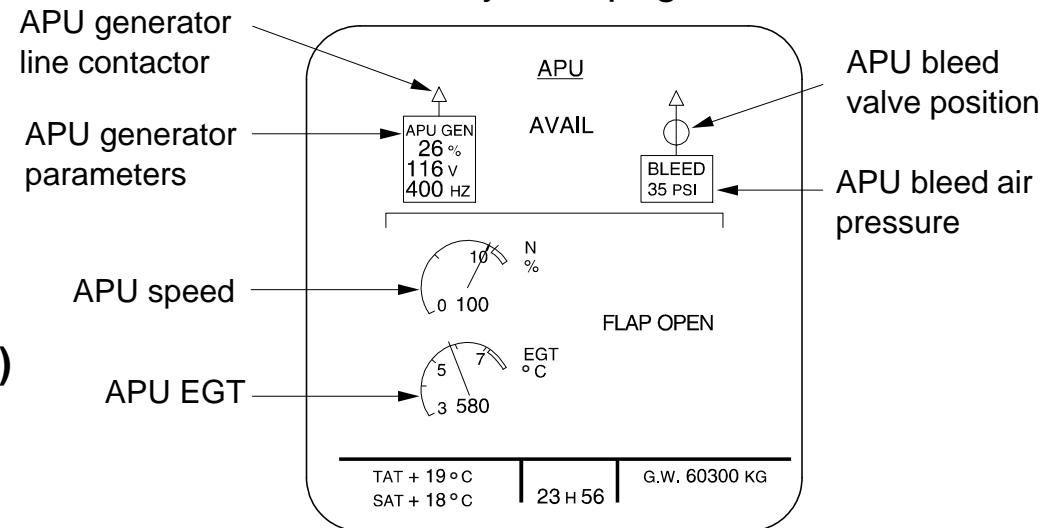



# A319/A320/A321 APU

---

- On ground, the APU makes the aircraft independent of pneumatics and electrical sources by :
  - providing bleed air for engine start and air conditioning systems;
  - providing electrical power to supply the electrical system,
- In flight, provision of back-up power for electrical and air conditioning systems,
- The APU may be started using either the aircraft batteries, external power or normal aircraft supply. The normal flight envelope does not impose any limitations for starting.
- The APU is automatically controlled by the Electronic Control Box (**ECB**) which is mainly acting as FADEC for monitoring start and shut-down sequences, bleed air and speed/temperature regulation.
- Control and displays :
  - on the overhead panel for APU normal operation and fire protection
  - on the ECAM for APU parameters display
  - on the external panel, under the nose fuselage, for APU shut down.





---

# 10. Automaticflight system

# A319/A320/A321 FMGS system architecture

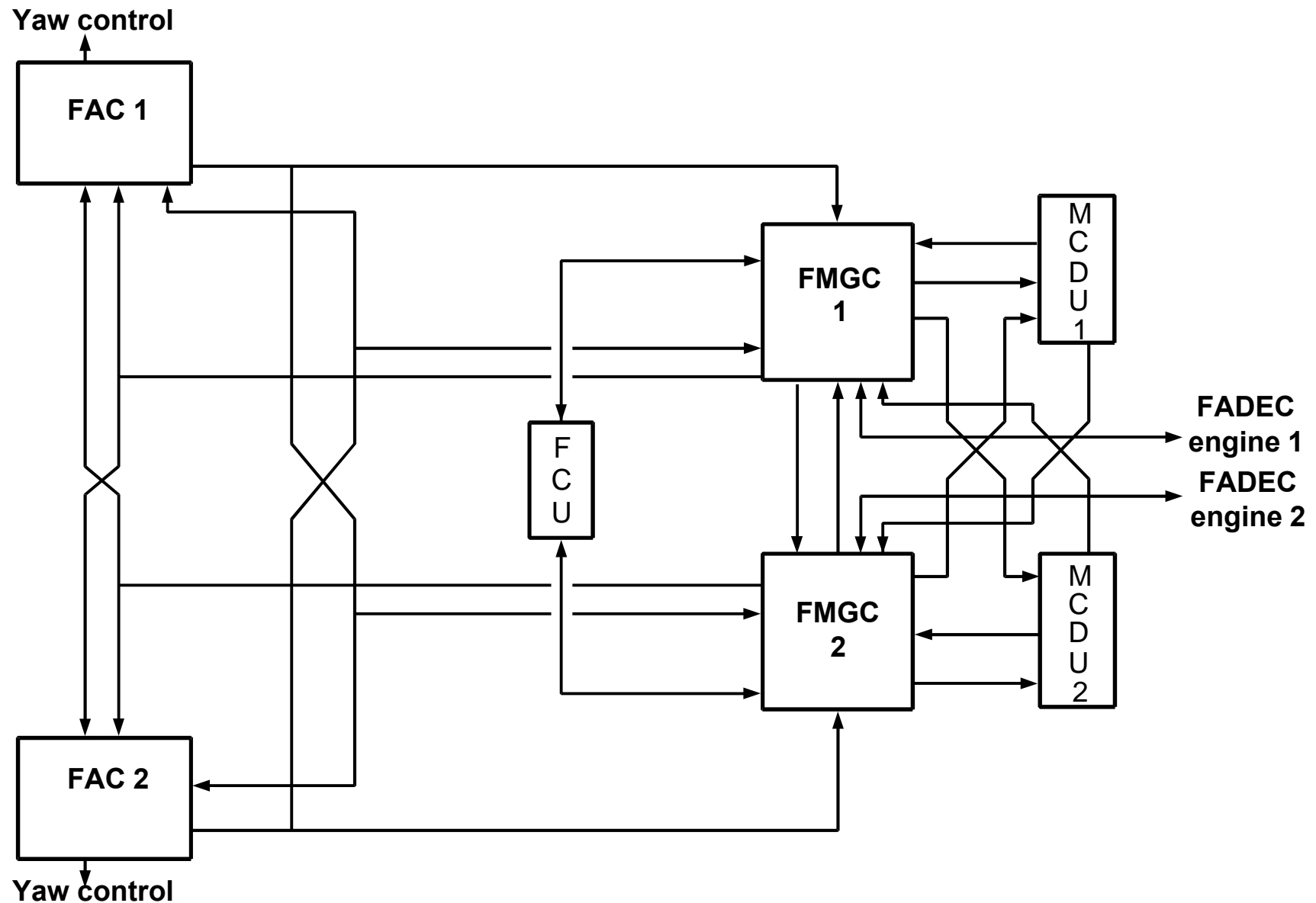

# A319/A320/A321 FMGS – AFS/FMS integration

---

- Composed of two Flight Management and Guidance Computers (FMGC), this pilot interactive system provides :
  - flight management for navigation, performance optimization, radio navaid tuning and information display management,
  - flight guidance for autopilot commands (to EFCS), flight director command bar inputs and thrust commands (to FADECs).
- Two **FACs** (Flight Augmentation Computer) provide :
  - rudder commands (yaw damping, rudder trim and limiting, turn coordination, automatic engine failure compensation),
  - flight envelope and speed computation.
- For operational convenience the FMGS offers two types of guidance concept :
  - managed according to FMGS flight plan data entered into the Multipurpose Control and Display (**MCDU**),
  - selected by the pilot through the Flight Control Unit (**FCU**).
- The AP/FD achieves either :
  - automatic control of the aircraft with regard to speed, lateral path and vertical plan as computed by the FMGCs,
  - manual control of the aircraft with regard to speed and vertical plan (selected through FCU), lateral path (through FMGC or FCU).

# A319/A320/A321 FMGS – system interface

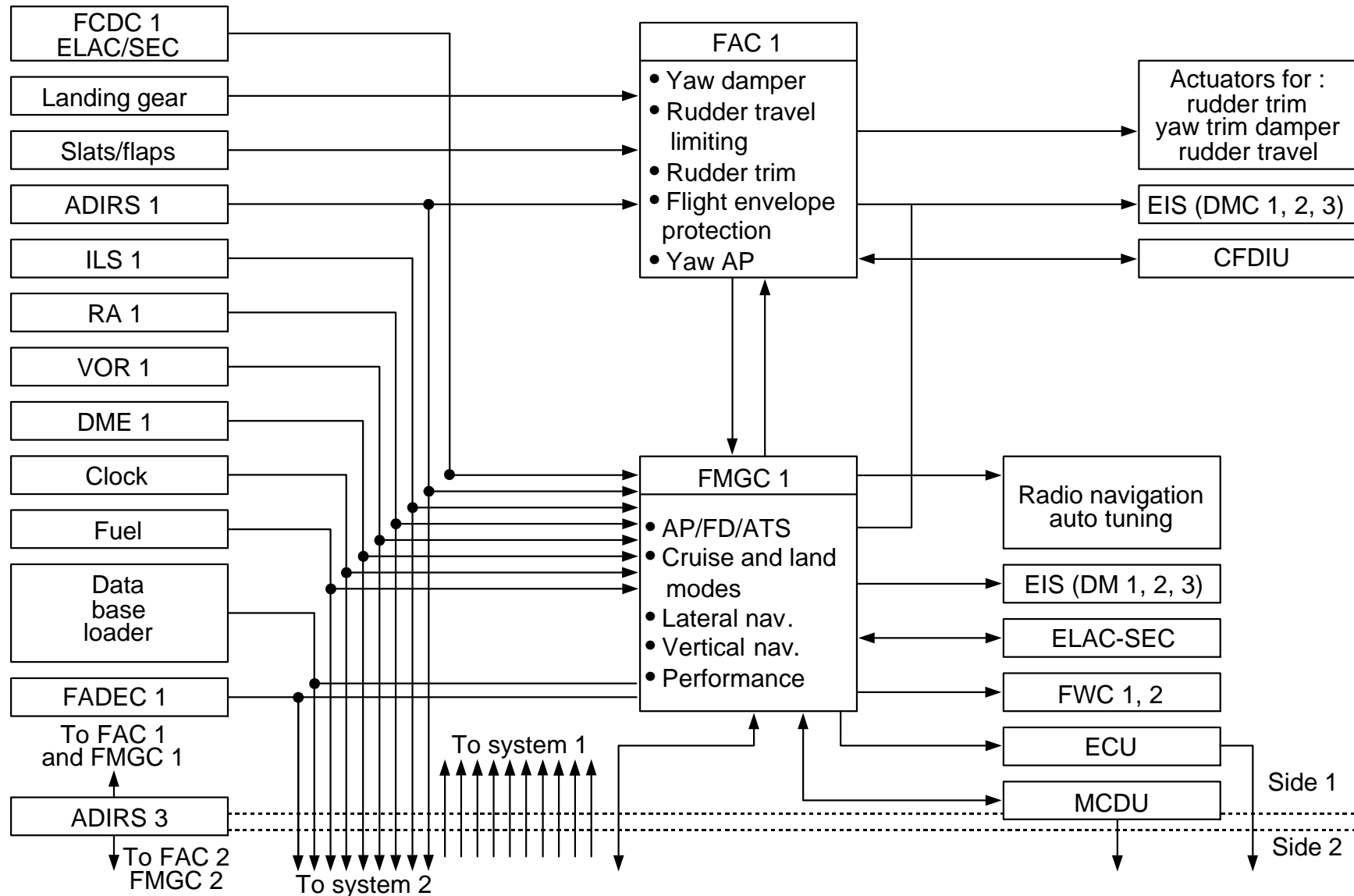

# A319/A320/A321 FMGS – system redundancy

Two FMGCs associated to two MCDUs provide a redundant configuration.

- Normal mode operation : **dual mode**

- Each FMGC makes its own computation
- One FMGC is **MASTER** – the other one is **SLAVE**
- Both MCDUs act independently (entries are automatically recopied on the other MCDU and applied to both FMGCs)

- **Independent mode**

- Automatically operative if mismatch between FMGCs
- Independent operation of FMGCs with associated MCDUs. (Data insertion and display related to the side concerned).
- One FMGC remains master.

- **Single mode**

- One FMGC fails
- Either MCDU can be used to enter or display data related to the remaining FMGC.

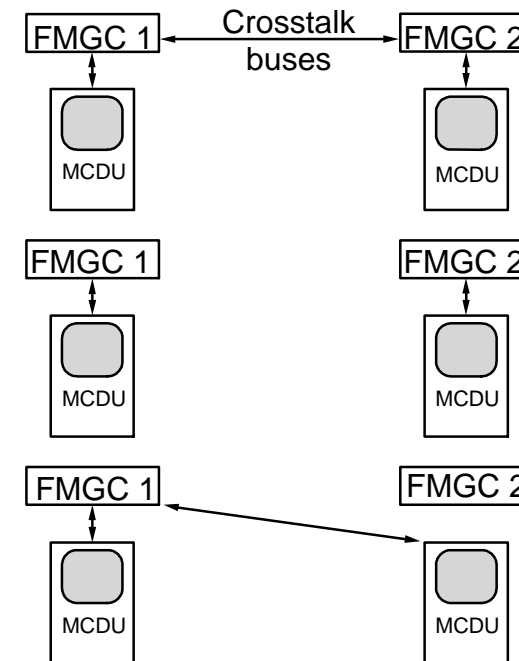

# A319/A320/A321 FMGS crew interface

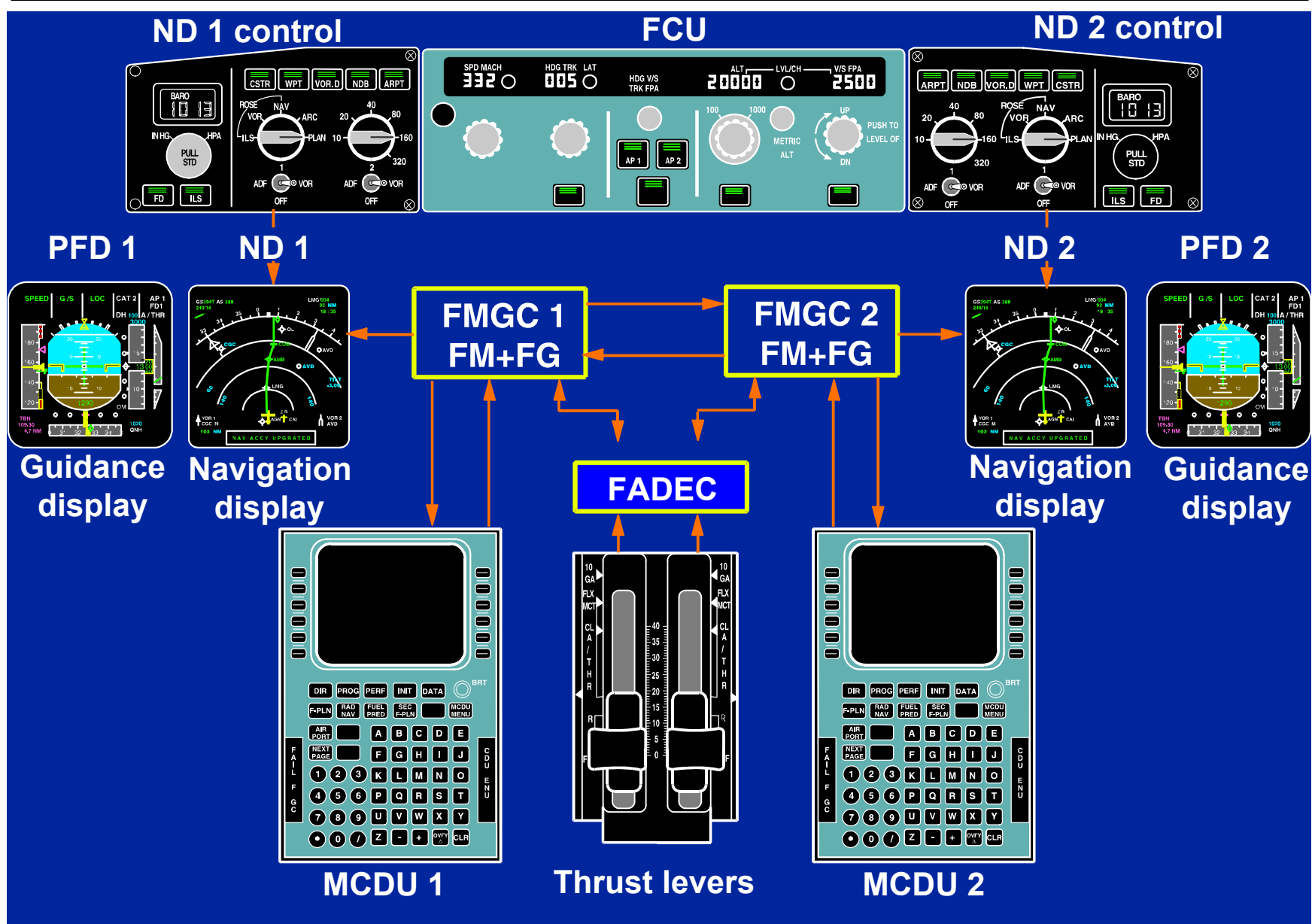



# A319/A320/A321 FMGS crew interface

---

- Two MCDUs on the central pedestal provide long-term interface between the crew and FMGCs in terms of :
  - flight plan definition and display
  - data insertion (speeds, weights, cruise level, etc)
  - selection of specific functions (direct to, offset, secondary flight plan).
- One FCU on the central glareshield to provide short-term interface between crew and FMGCs.
- Two thrust levers linked to the FMGCs and FADECs provide autothrust or manual thrust control selection to the crew.
- Two PFDs and two NDs provide visual interface with flight management and guidance related data such as :

## **on PFD :**

- FMGS guidance targets,
- armed and active modes
- system engagement status

## **on ND :**

- flight plan presentation,
- aircraft position and flight path,
- navigation items (radio navaid, wind).

# A319/A320/A321 FMGS flight guidance

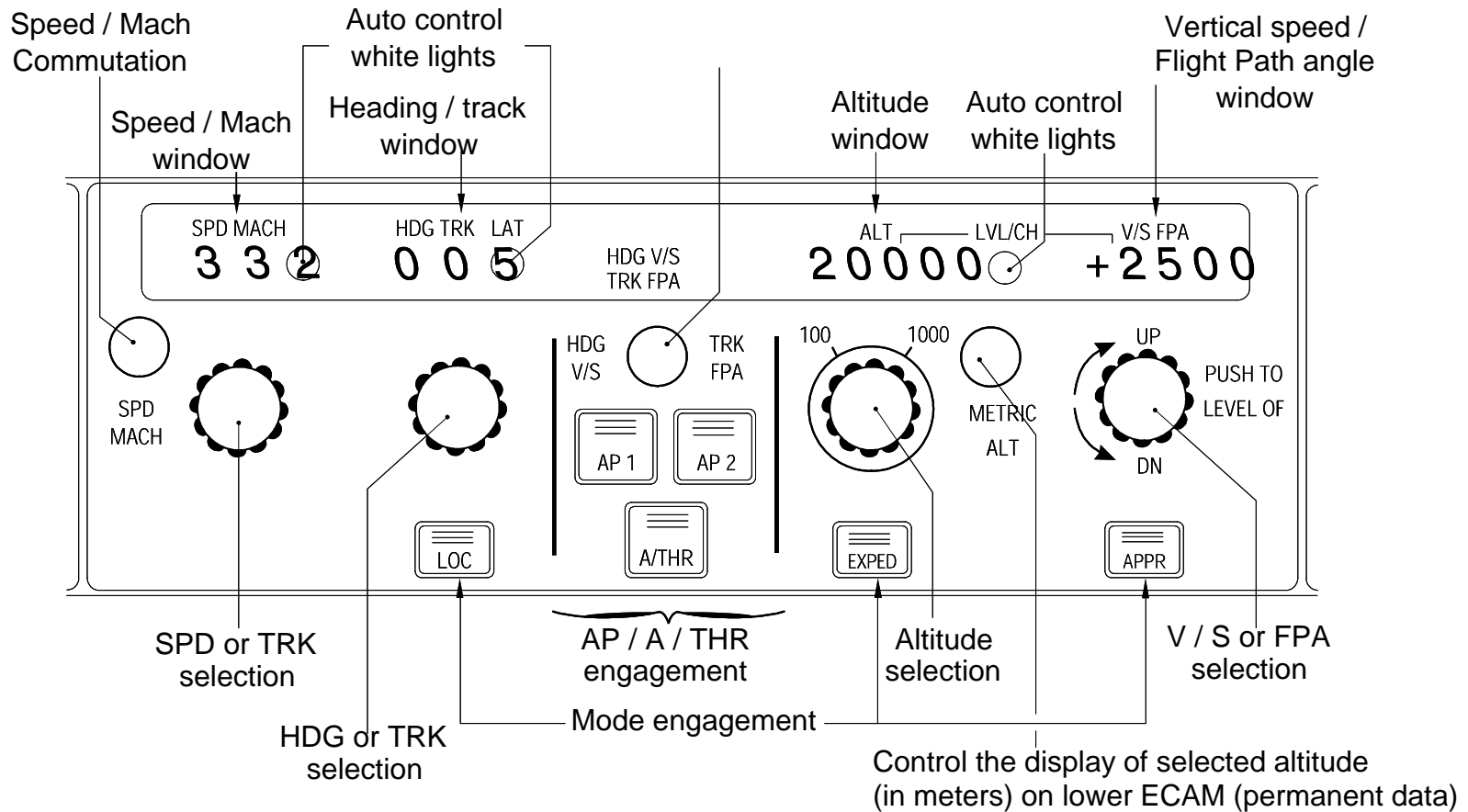

- Managed guidance parameter window is dashed and auto control illuminated.

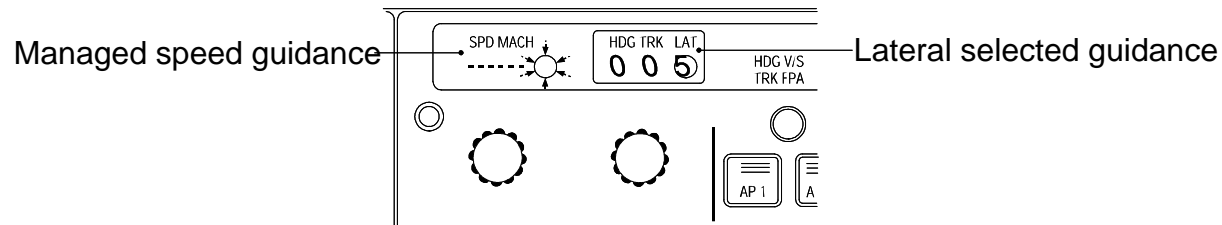

# A319/A320/A321 FMGS flight guidance

---

- The **FCU** is the main crew interface for short-term guidance with a single rule for the various control knobs :
  - pull + rotate = pilot input
  - push = return to FMGS control.
- As an example, a change of altitude can be achieved by a double action on the FCU :
  - either by selection of a new altitude through the FCU selector and validation of this new altitude pushing (management guidance) this knob.
  - or by selection of a V / S through the FCU selector and validation of this new V / S by pulling this knob.
- Actions on the FCU are displayed on the FCU as well as on the PFD in the dedicated **FMA** (Flight Management Annunciator) part.

# **A319/A320/A321 FMGS flight management**

---

## **Flight plan stringing**

Flight plan definition by company route or city pair.

Departure and arrival procedures including associated, speed/altitude/time constraints.

Flight plan revision (offset, DIR, TO, holding pattern, alternative flight plan activation,...)

Secondary flight plan creation similar to primary flight plan.

## **Navigation**

Automatic guidance along flight plan from take-off to approach.

Aircraft position determination.

Aircraft position referenced to the flight plan.

Automatic VOR/DME/ILS/ADF selection.

IRS alignment.

Ground speed and wind computation.

Optimum radio and inertial sensor mixing.

Provision for GPS and MLS.

# A319/A320/A321 FMGS performance management

---

- Flight plan optimization, through the performance data base, in terms of :
  - optimum speeds
  - optimum altitudes.
  
- The computations are based on :
  - flight conditions (cruise level, weights, center of gravity, meteorological data)
  - cost index
  - speed entered on the FCU or given in the flight plan.
  
- Performance predictions :
  - time, altitude, speed at all waypoints
  - estimated time of arrival, distance to destination, estimated fuel on board at destination.
  
- Advisory functions :
  - fuel planning
  - optimum altitudes and step climb.
  
- Full vertical guidance related to flight plan predictions from initial climb to approach.

# A319/A320/A321 FMGS - lateral navigation

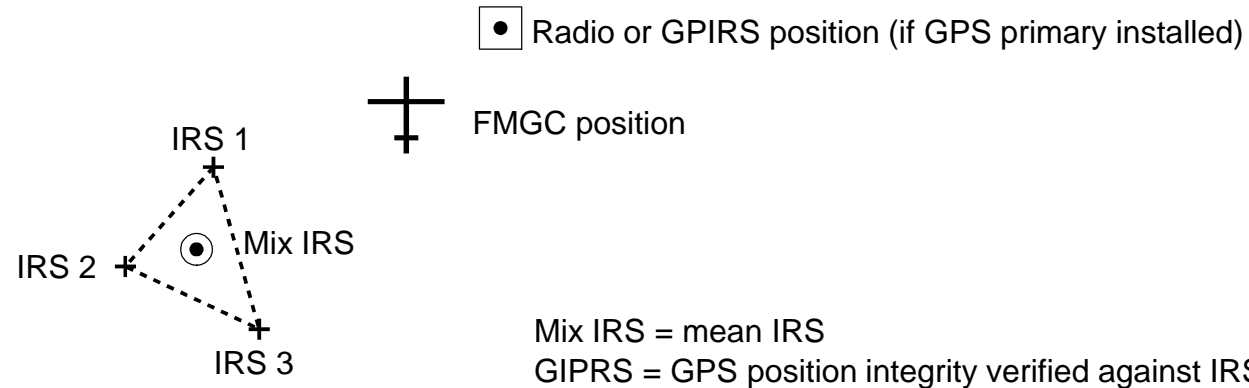

**POSITION MONITOR**

1		5		10		15		20		24
<b>POSITION MONITOR</b>										
1L	FMGC1	4610 .2N/00618 .3E								1R
		3 IRS/DME/DME								
2L	FMGC2	4610 .2N/00618 .8E								2R
		3 IRS/DME/DME								
3L	RADIO	4610 .1N/00618 .2E								3R
4L	MIX IRS	4609 .7N/00618 .0E								4R
	IRS 1	IRS 2	IRS 3							
5L	NAV 0.4	NAV 0.2	NAV 0.4							5R
6L	←FREEZE									6R

**SELECTED NAVAIDS**

1		5		10		15		20		24
<b>SELECTED NAVAIDS</b>										
	VOR/DME	AUTO	DESELECT							
1L	<GEN	115 . 20	(							1R
	VOR/DME									
2L	<NIZ	115 . 10								2R
	VOR/DME									
3L	<TOP	115 . 40								3R
4L										4R
5L										5R
6L	<RETURN									6R

→ To see the nav aids used for radio position

# A319/A320/A321 FMGS - lateral navigation

---

- Position computation :

- before flight, the three IRSs are aligned on airfield or gate position. (manually or via database)
- at take-off, the position is automatically updated to the runway threshold
- in flight, position updating is computed using GPS if installed, and radio nav aids (DME, VOR, ILS)

The FMGC position depends upon the IRS's mean, the GPS and the radio position.

- Navigation mode selection :

- if the aircraft is equipped with GPS primary, the FMGC uses GPIRS position in priority
- if the GPIRS position is not available or if the aircraft is not equipped with GPS primary, depending upon availability of nav aids and sensors, FMGC automatically tunes the best nav aids to compute the most accurate position.

The navigation modes may be :

**En route :**

IRS – GPS (if GPS installed)  
IRS – DME  
IRS – VOR/DME  
IRS only

**In approach :**

IRS – GPS (if GPS installed)  
IRS – DME  
IRS – VOR/DME  
IRS – ILS/DME

# A319/A320/A321 FMGS - lateral navigation

## MCDU

	CRZ	ECON DES	OPT	REC MAX	
1L	FL290	FL350	FL390		1R
2L	REQD DIST	TO LAND = 70NM			2R
	DIR DIST	TO DEST = 89NM			
3L		BRG / DIST			3R
4L		---* / ---	TO ( )		4R
			UPDATE AT		
5L			( )*		5R
6L	VOR 1 / FREQ	ACY	FREQ / VOR 2		6R
	ATH / 114.4	HIGH	117.2 / DDM		

## ND

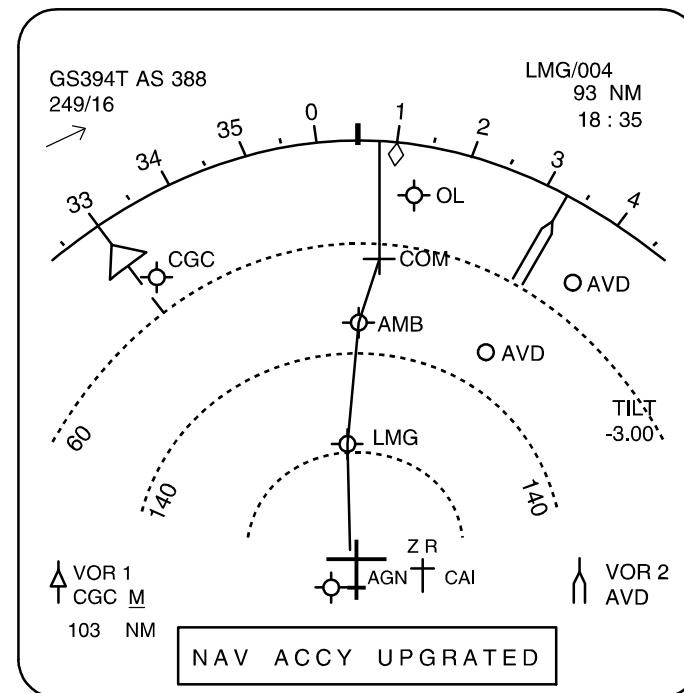



# A319/A320/A321 FMGS - lateral navigation

---

- FMGC provides the crew with lateral position and its associated accuracy criteria which depend upon :
  - FMGC Error Position Estimate (**EPE**)
  - zone currently flown (en route, terminal, approach)
  - Airworthiness Authorities Accuracy Requirements (**AAAR**)
- If  $EPE \leq AAAR$  then HIGH is displayed on MCDU and the computed positions may be used without restriction.
- If  $EPE > AAAR$  then LOW is displayed on MCDU and the position must be cross-checked with raw data (ADF/VOR needles, DME reading).
- Each time HIGH (or LOW) reverts to LOW (or HIGH) the message NAV ACCY DOWNGRADED (or UPGRADED) is displayed on NDs and MCDUs.

# A319/A320/A321 flight deck – main features

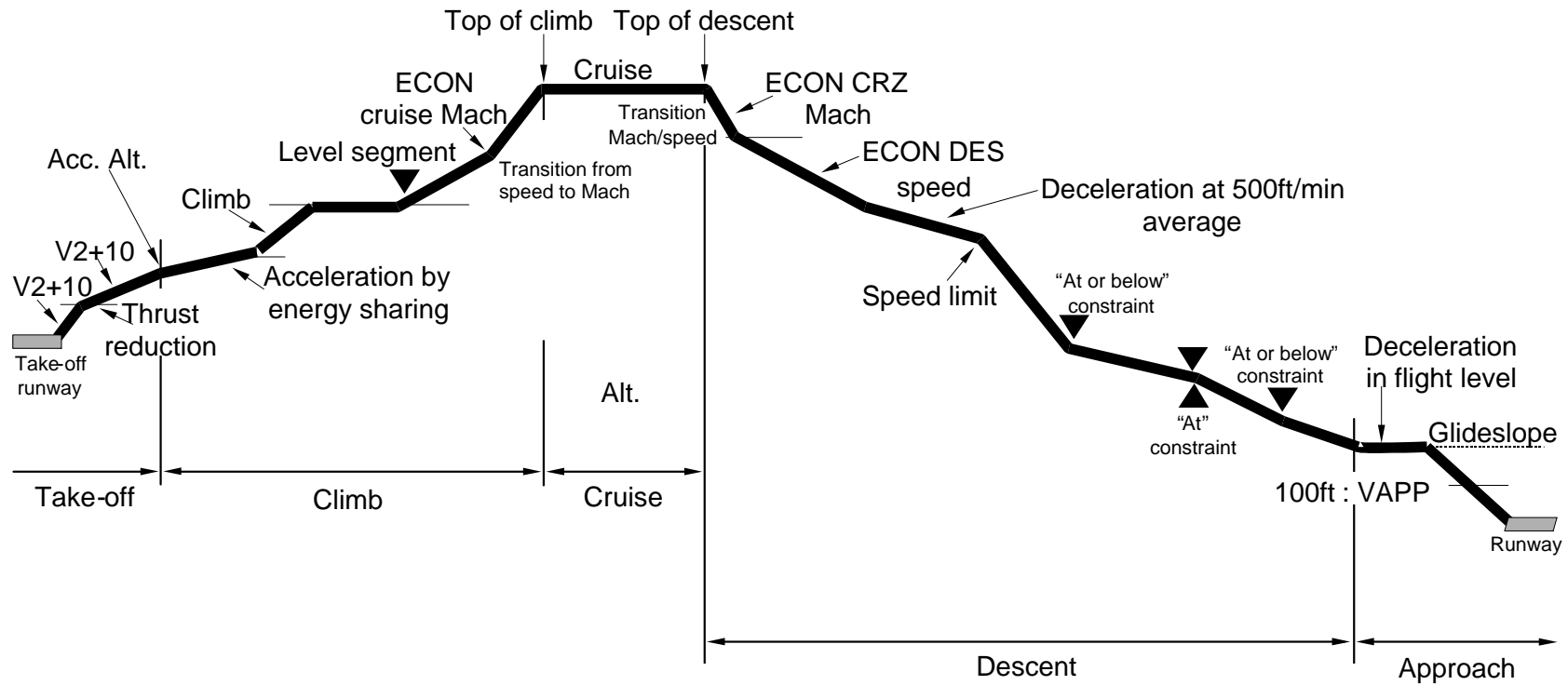

# A319/A320/A321 FMGS – vertical profile

---

- **Take-off :**

SRS control law maintains  $V_2 + 10$  up to thrust reduction altitude where max climb thrust is applied.  $V_2 + 10$  is held up to acceleration altitude (ACC LT).

- **Climb :**

Energy sharing is applied for acceleration (70% thrust) and for altitude (30% thrust) from ACC ALT up to first climb speed. Max climb thrust is kept – Altitude constraints are taken into account.

- **CRZ :**

Steps may exist and/or may be inserted.

- **Descent :**

Top of Descent (T/D) is provided on ND.  
From T/D down to the highest altitude constraint, ECON descent speed is supposed to be held on elevator and IDLE +  $\Delta$  on thrust.  
Then, if this status can no longer be kept, geometric segments will be followed between the constraints.

- **Approach :**

From DECEL point a deceleration allows configuration changes in level flight.

Approach phase is planned to reach approach speed at 1000ft above ground level.

# A319/A320/A321 FMGS – AP / FD modes

Guidance	Managed	Selected
Lateral	<ul style="list-style-type: none"> <li>● NAV and APP NAV</li> <li>● APPR</li> <li>● LOC</li> <li>● RWY</li> <li>● RWY TRK</li> <li>● G.A. TRK</li> </ul>	<ul style="list-style-type: none"> <li>● HDG - TRK</li> </ul>
Vertical	<ul style="list-style-type: none"> <li>● CLB</li> <li>● DES</li> <li>● SRS (TO / GA)</li> <li>● G / S</li> <li>● FLARE</li> <li>● FINAL</li> </ul>	<ul style="list-style-type: none"> <li>● OP CLB</li> <li>● OP DES</li> <li>● Expedite (towards altitude selected on FCU but managed speed)</li> <li>● ALT</li> <li>● V / S – FPA</li> </ul>
Speed	<ul style="list-style-type: none"> <li>● F. PLN reference (ex. : optimum)</li> <li>● Expedite</li> </ul>	<ul style="list-style-type: none"> <li>● FCU selected</li> </ul>

# A319/A320/A321 FMGS – AP / FD modes

---

## ● Managed guidance

### Take-off :

- **RWY** : automatic runway axis follow up through ILS use
- **RWY. TRK** : follow up of the memorized runway axis
- **SRS** : pitch guidance to maintain  $V_2 + 10$

### Climb/Cruise/Descent :

- **NAV** : lateral guidance along the defined F.PLN
- **CLB/DES** : vertical guidance with respect of all the F.PLN defined constraints
- **APP NAV** : lateral guidance along a defined non precision approach

### Approach and landing :

- **APPR** : ILS approach (ILS beams capture and track) and non precision approach
- **LOC** : LOC use only (capture and track)
- **FLARE** : automatically performed around 30ft
- **FINAL** : vertical guidance along a defined non precision approach

## ● Selected guidance

### Lateral :

- **HDG/TRK** : selected on FCU

### Vertical :

- **OP CLB/OP DES** : open modes for level changes with a fixed thrust and speed held on elevator
- **EXPED** : level change with maximum climb/descent
- **ALT** : altitude capture and hold
- **V/S-FPA** : vertical speed or flight path angle track

# A319/A320/A321 ATS – controls and display

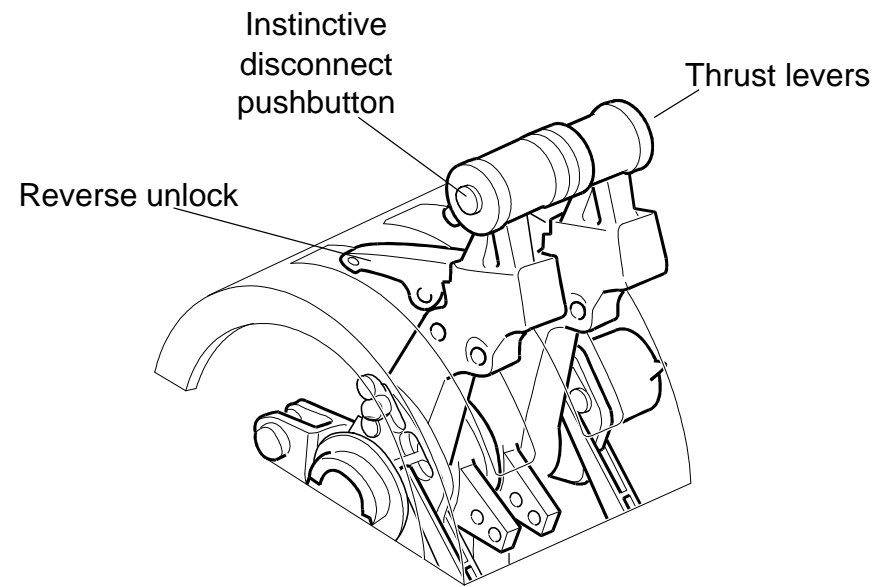
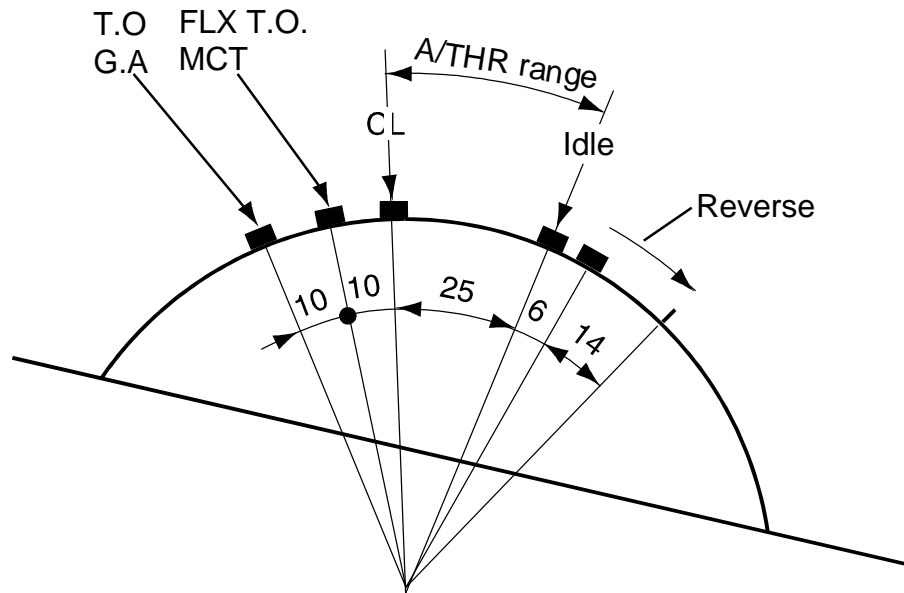

## FCU

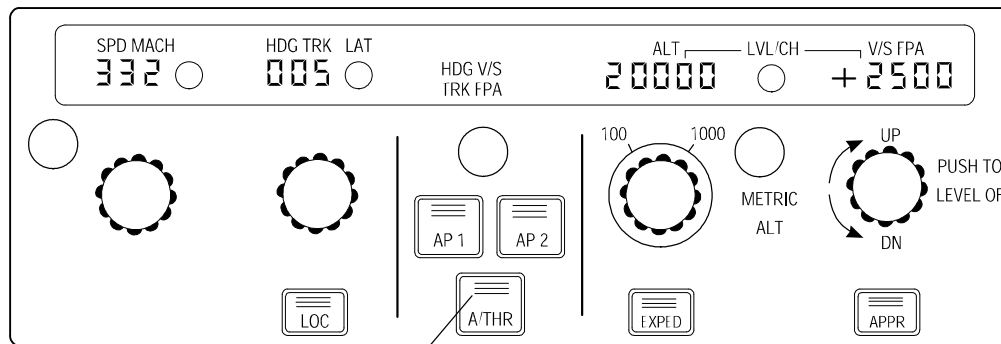

Illuminated green when A/THR engaged

## PFD

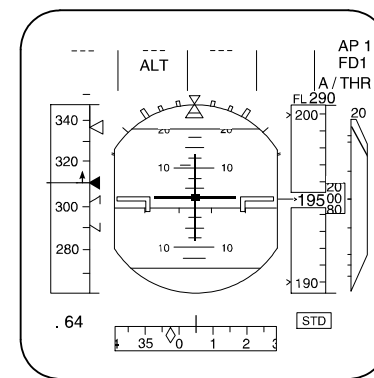

Displayed  
- Cyan when engaged  
- White when active

# A319/A320/A321 FMGS – autothrust function

---

- Autothrust (**A/THR**) is part of FMGC
- No mechanical linkage between levers and engines. Thrust levers position is measured and transmitted to the FADEC in digital form.
- Autothrust :
  - either ensures thrust control depending upon AP/FD modes (if these are engaged)
  - or manages thrust to hold the current target speed (if no AP/FD engaged)
  - thrust control is achieved without moving the levers.
- A/THR engagement status and thrust limit mode depend upon thrust lever angle (TLA). Thrust limit selection and computation are made by the FADEC.
- 5 positions are fitted within the levers position range.

# A319/A320/A321 FMGS – autothrust function

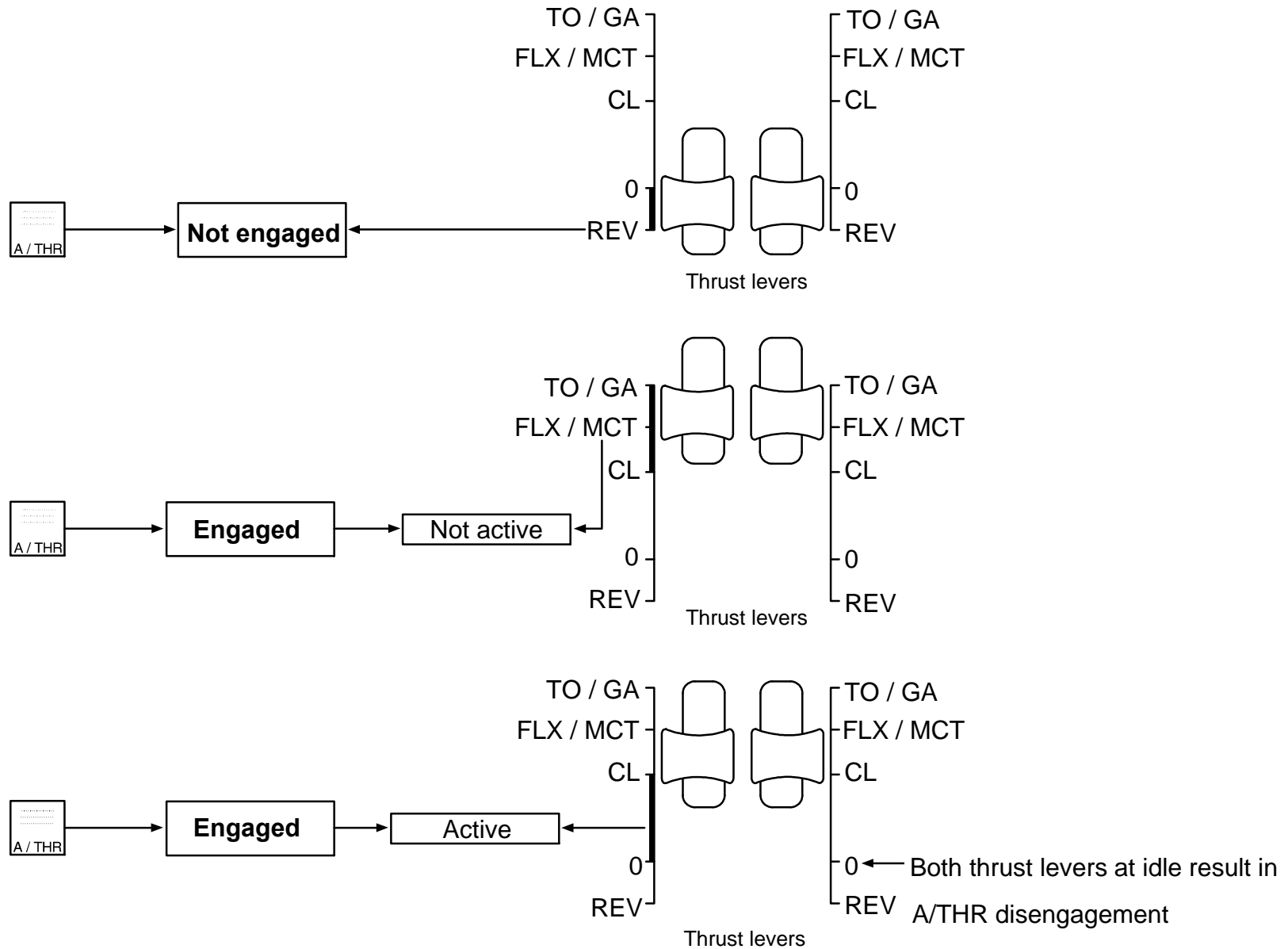



# A319/A320/A321 FMGS – autothrust function

---

## Operational rules

- A/THR can be engaged :
  - manually by pressing the A/THR pushbutton
  - automatically, by setting the thrust levers at TO/GA or FLEX position.
- A/THR is then activated if thrust levers are set between CL (included) and IDLE (excluded) gates.  
In this case, commanded thrust is limited by TLA (except ALPHA-FLOOR activation).
- A/THR not active (A/THR p/b on FCU extinguished) and thrust levers within A/THR range } Pressing A/THR p/b on FCU activates A/THR
- A/THR can be disengaged by :

Depressing the instinctive disconnect P/B on the levers or depressing the illuminated A/THR P/B on FCU or setting both thrust levers in IDLE gate.

# A319/A320/A321 FMGS – autothrust function

- If the levers are in CLB gate and A/THR is disengaged then :
  - thrust is frozen at its current value until thrust levers are moved out of the gate.  
THR LK amber message appear on PFD.
- If the levers are not in CLB gate when A/THR is disengaged then :
  - thrust is not frozen but is set according to the lever position.
- Engagement of A/THR mode is automatic according to AP/FD engaged mode :

<b>AP/FD mode</b>	<b>ATS mode</b>
V/S-FPA ALT (ACQ/HOLD)	SPD/Mach
Expedite	Thrust
Descent/Climb	Thrust/SPD/Mach
SPD/Mach	Thrust
Approach final descent glide flare	SPD SPD Retard
TO/ GA	ATS Armed

# A319/A320/A321 FMGS – autothrust function

---

## Autothrust operation

- Take-off performed :
    - in TO limit mode with levers in TO.GA notch
    - in FLEX TO limit mode with levers in FLX TO/MCT detent provided a FLX temperature has been entered on MCDU (take-off page). Lowest FLX TO thrust is automatically limited to CL thrust.

Note : In both cases, this manoeuvre also engages the flight director TO mode.

  - Once out of take-off (or go around), the nominal phases in autothrust are always :
    - CL gate in twin engine situation
    - MCT gate in single engine situation

} This is indicated to the crew by a CLB or MCT message on PFD

  - One lever in CL gate and the other out of this gate (in twin-engine operation) causes the engines to be regulated differently. ASYM amber message appears on PFD
- In approach, A/THR control depends on type of approach (ILS, non precision) and vertical mode selected on FCU.
- If Alpha floor function is activated, TO/GA thrust is automatically applied whatever the lever position and A/THR status are.





---

# 11. Environmentalcontrol system



# A319/A320/A321 ECS – system schematic

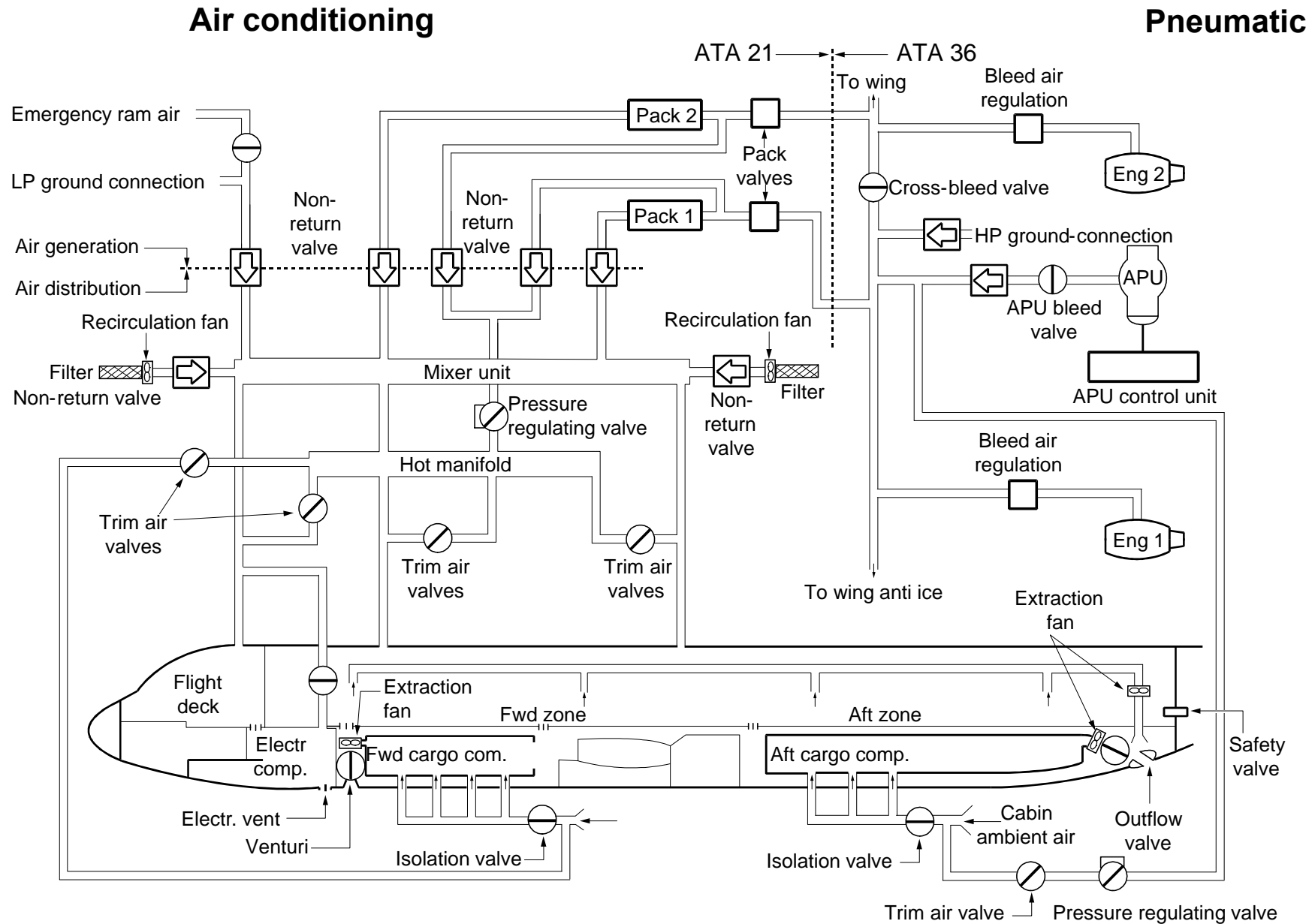

# A319/A320/A321 ECS – temperature and flow control

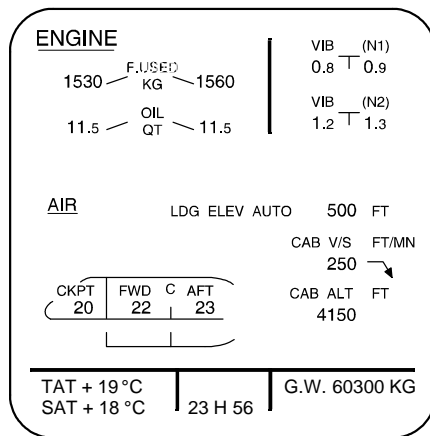

**System display :**  
Cruise page

Variable flow selector  
Space optional  
FWD + AFT cargo heat

Automatic temperature control selectors  
Flight deck

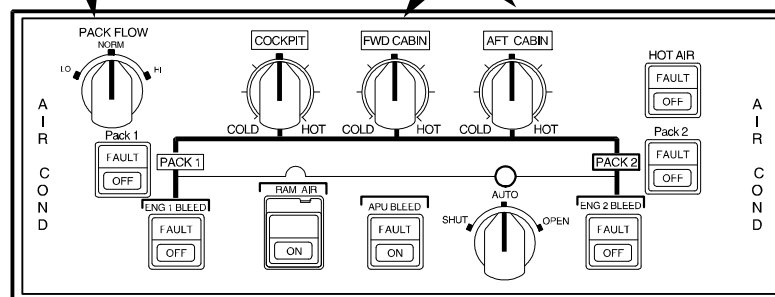

**A319/A320**

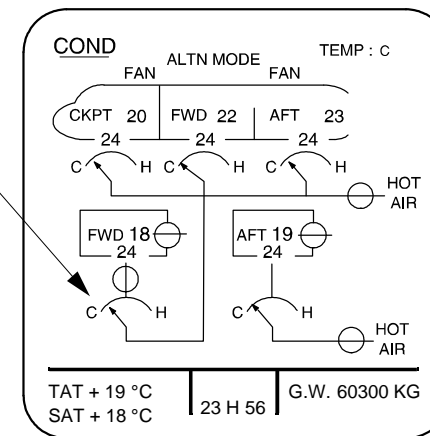

**System display :**  
CON system page

**Cargo heat - optional**

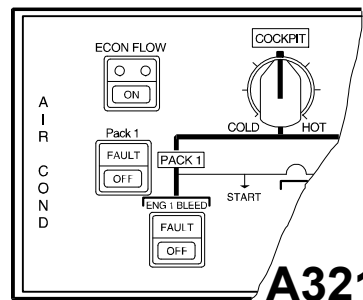
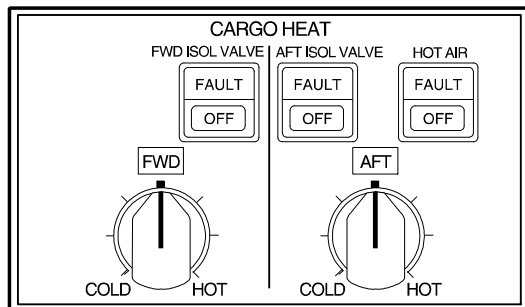

**System display :**  
BLEED system page

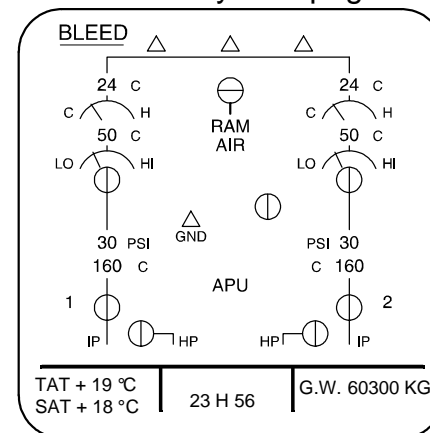



# A319/A320/A321 ECS – air conditioning – pneumatic - general

---

## Air conditioning

Continuous air renewal and temperature regulation in three independently controlled zones (cockpit, forward cabin, aft cabin).

Downstream both packs, a dedicated unit mixes cold air with recirculated cabin air for distribution to the three zones.

Optimized air temperature is obtained by adding engine hot air to mixing unit air via three trim air valves.

Cabin and pack temperature regulation are achieved by a **zone controller** and two **pack controllers**.

## Pneumatic

High pressure air is supplied for air conditioning, air starting, wing anti-ice, water pressurization, hydraulic reservoir pressurization.

System operation is electrically monitored by two Bleed Monitoring Computers (**BMC**), and is pneumatically controlled.

A leak detection system is provided to detect any overheat in the vicinity of the hot air ducts.

# A319/A320/A321 ECS flight deck – main features

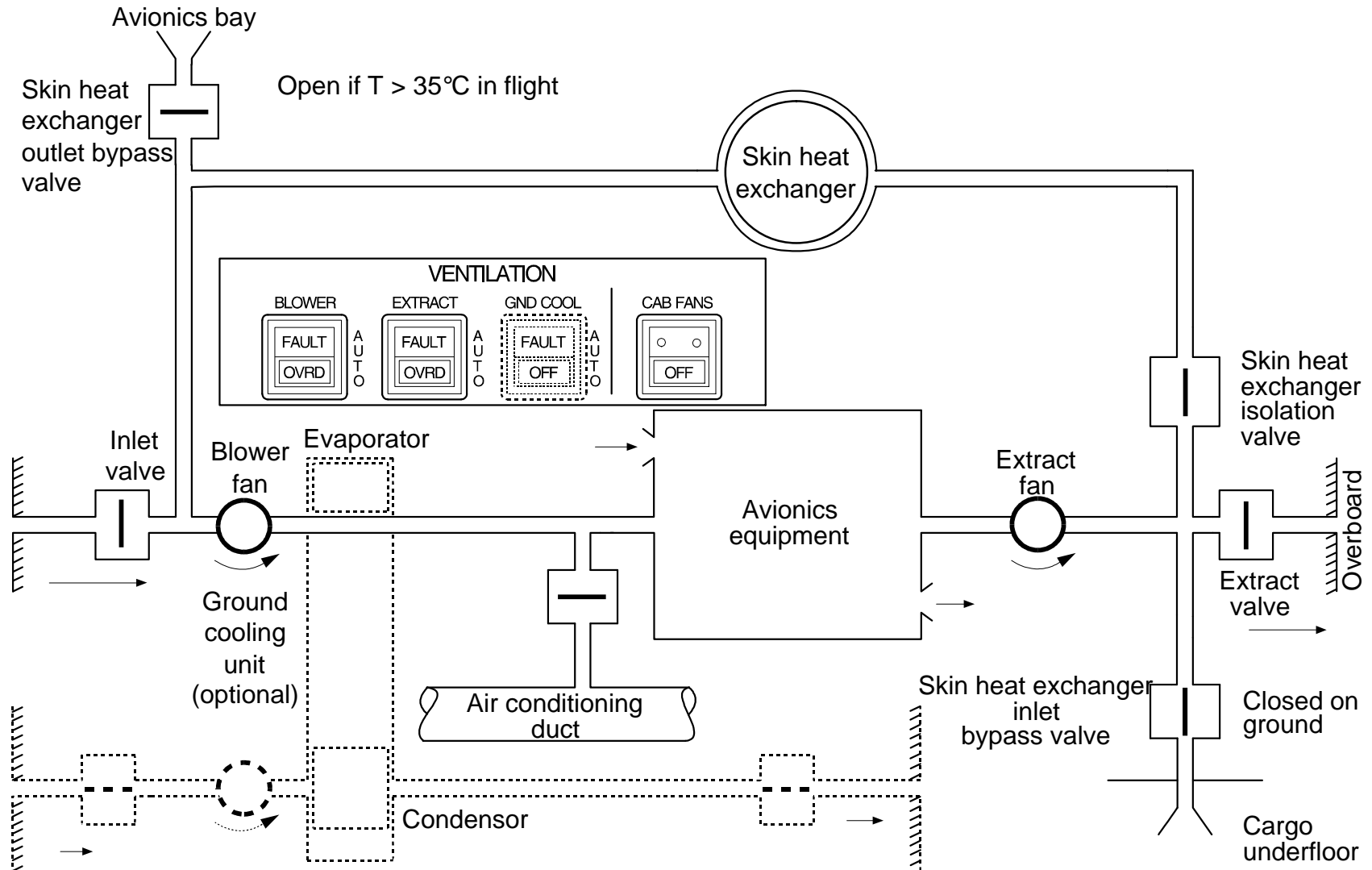

# **A319/A320/A321 ECS - ventilation**

---

## **Avionics ventilation**

Provide ventilation and cooling of avionics and electronic equipment under digital control (**AEVC**) and without any crew intervention.

Three main operational configurations are automatically selected :

- closed-circuit configuration (flight) by means of an aircraft skin heat exchanger and a pair blower and extract fans,
- open-circuit configuration using outside fresh air through opening of inlet and extract valves,
- an intermediate flight configuration is selected in case of high temperature, whereby the skin exchanger outlet bypass valve is opened and the extract valve is maintained half open.

## **Battery ventilation**

Achieved by ambient air being drawn around the batteries and then vented directly outboard via a venturi.

## **Lavatory & galley ventilation**

Achieved by ambient cabin air extracted by a fan exhausted near the outflow valve.

# A319/A320/A321 ECS – cabin pressure control

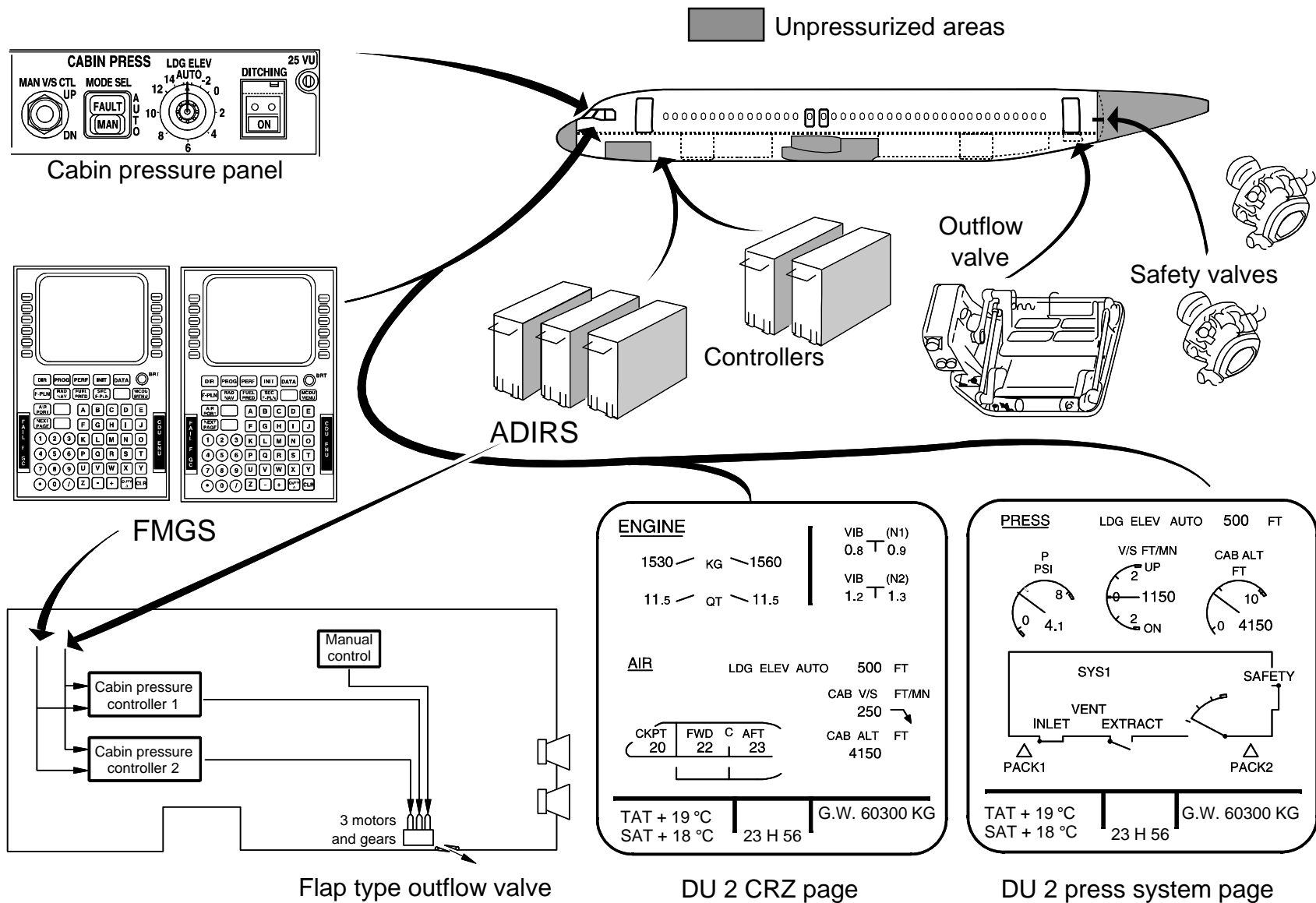

# A319/A320/A321 ECS – pressurization

---

- The pressurization control system operates fully automatically without any crew action.
- Dual system with automatic switchover after failure. Alternative use for each flight. A single outflow valve is operated by one of three independent electric motors. Two of these are associated with automatic controllers.
- In normal operation, cabin altitude and rate of change are automatically controlled from FMGC flight plan data :
  - cruise FL, landing field elevation, QNH,
  - time to top of climb, time to landing.
- In case of dual FMGC failure, the crew has to manually select the landing elevation. The cabin altitude varies according to a preprogrammed law.
- In case of failure of both pressurization system auto-controllers, the manual back-up mode is provided through the third outflow valve motor.





---

# 12. Electronicinstrument system

# A319/A320/A321 EIS – EFIS/ECAM architecture

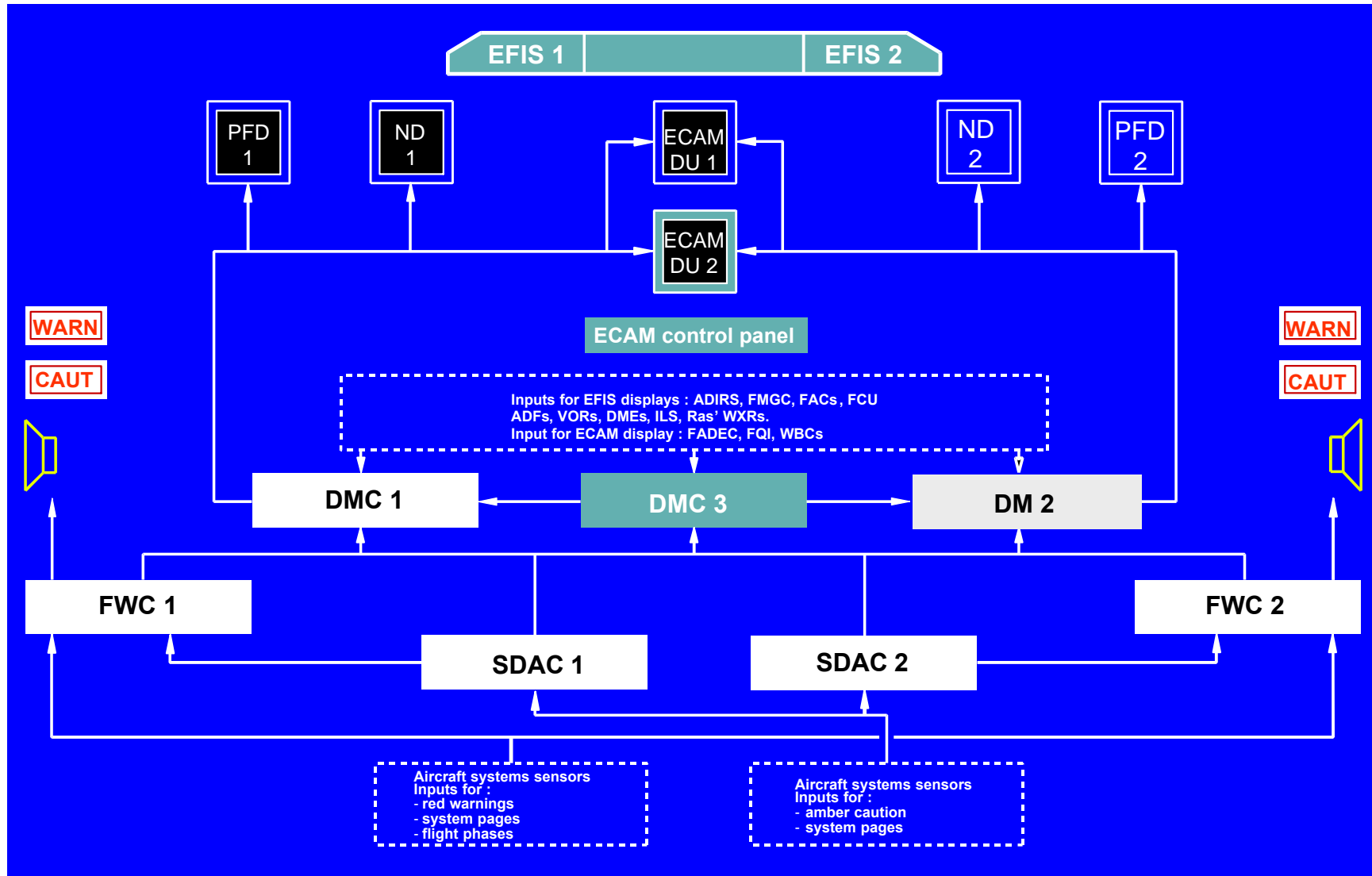



# **A319/A320/A321 EIS - components**

---

- Six identical (7.25 in x 7.25 in) cathode ray tubes Display Units (**DU**), including integrated graphics generator :
  - Two primary flight displays + two navigation display (**EFIS**)
  - One engine warning display + one system display (**ECAM**)
  
- Three Display Management Computers (**DMC**)
  - Generating images to be displayed on PFD, ND and ECAM Dus
  - Digital data link to display units
  - No.3 DMC may replace either No.1 or No.2
  
- Two System Data Acquisition Concentrators (**SDAC**)
  - Acquiring systems data for transmission of caution/warnings to FWCs and systems condition to DMCs
  - Operations not affected with either SDAC failure.
  
- Two Flight Warning Computers (**FWC**)
  - Generating alert messages, aural alerts and procedural messages for display on ECAM
  - operations not affected with either FWC failure.

# A319/A320/A321 EIS - EFIS arrangement

---

- Primary flight display
  - Attitude
  - Airspeed
  - Altitude/vertical speed
  - Heading
  - ILS deviation/marker
  - Radio altitude
  - AFS status (FMA)
  
- Navigation display, three modes :
  - **ROSE** mode (**ILS, VOR or NAV**) : aircraft symbol in screen centre, heading up with radar available
  - **ARC** mode : aircraft symbol in lower part of the screen, heading up with radar available
  - **PLAN** mode : display centred on selected waypoint, north up

Note : In ROSE-NAV, ARC and PLAN modes, map data from FMS are presented

# A319/A320/A321 EIS - PFD : climb – FMS guidance

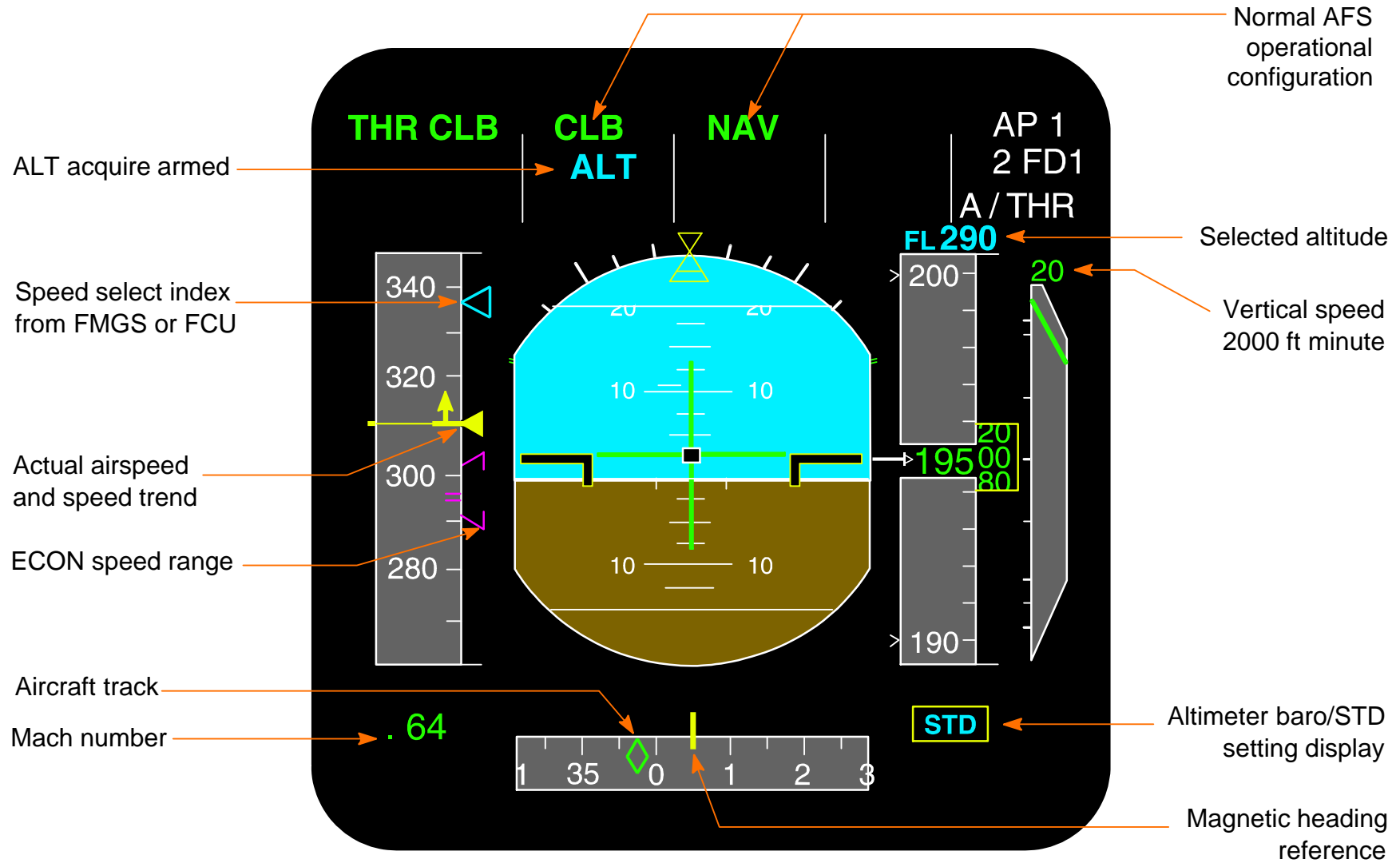

# A319/A320/A321 EIS - PFD : approach configuration

Approach capability and decision height

$V_{FE}$  or actual configuration  
 $V_{FE}$  of the next configuration

Minimum selectable speed  
 Alpha protection speed  
 Alpha max speed

Radio altitude  
 ILS ident + freq

ILS - DME distance

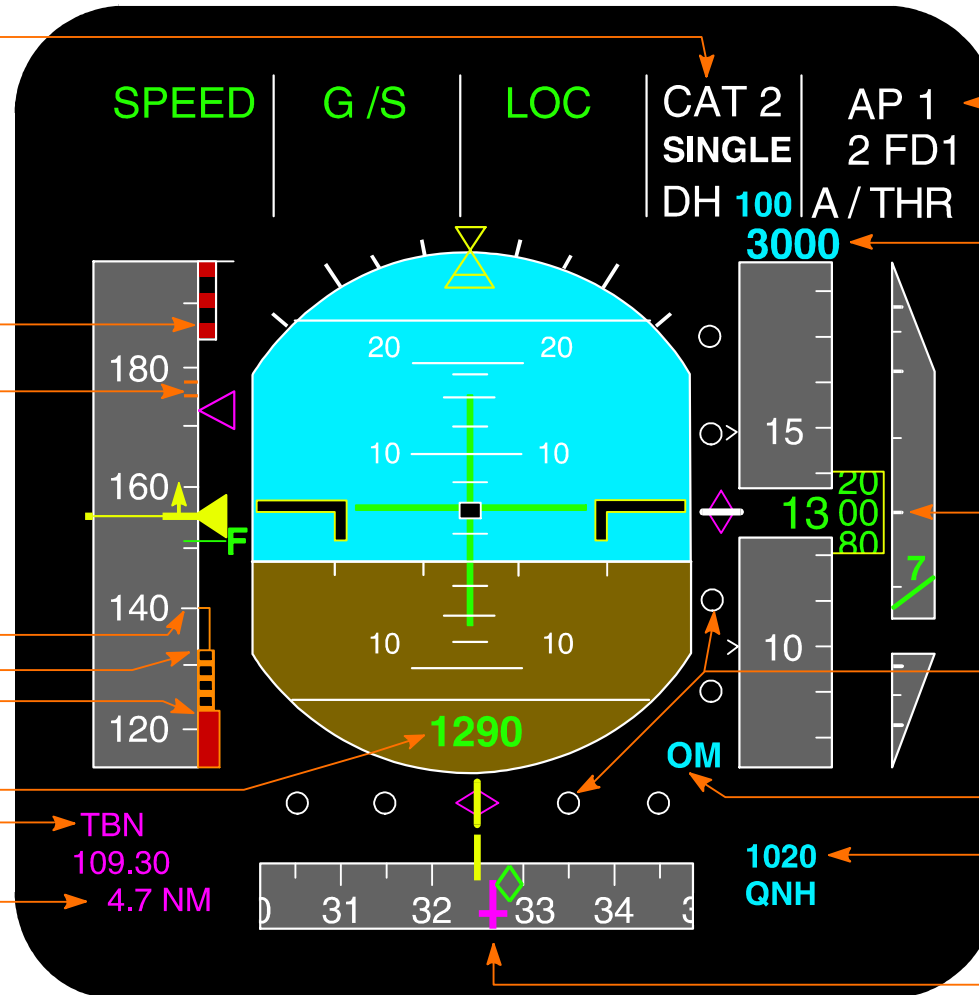

AP / FD and A / THR engagement status

Selected altitude

Altitude indication

G / S and LOC scales and DEV indexes

Outer marker "light"

Altimeter baro setting display

ILS course

# A319/A320/A321 EIS - ND : ROSE / VOR mode

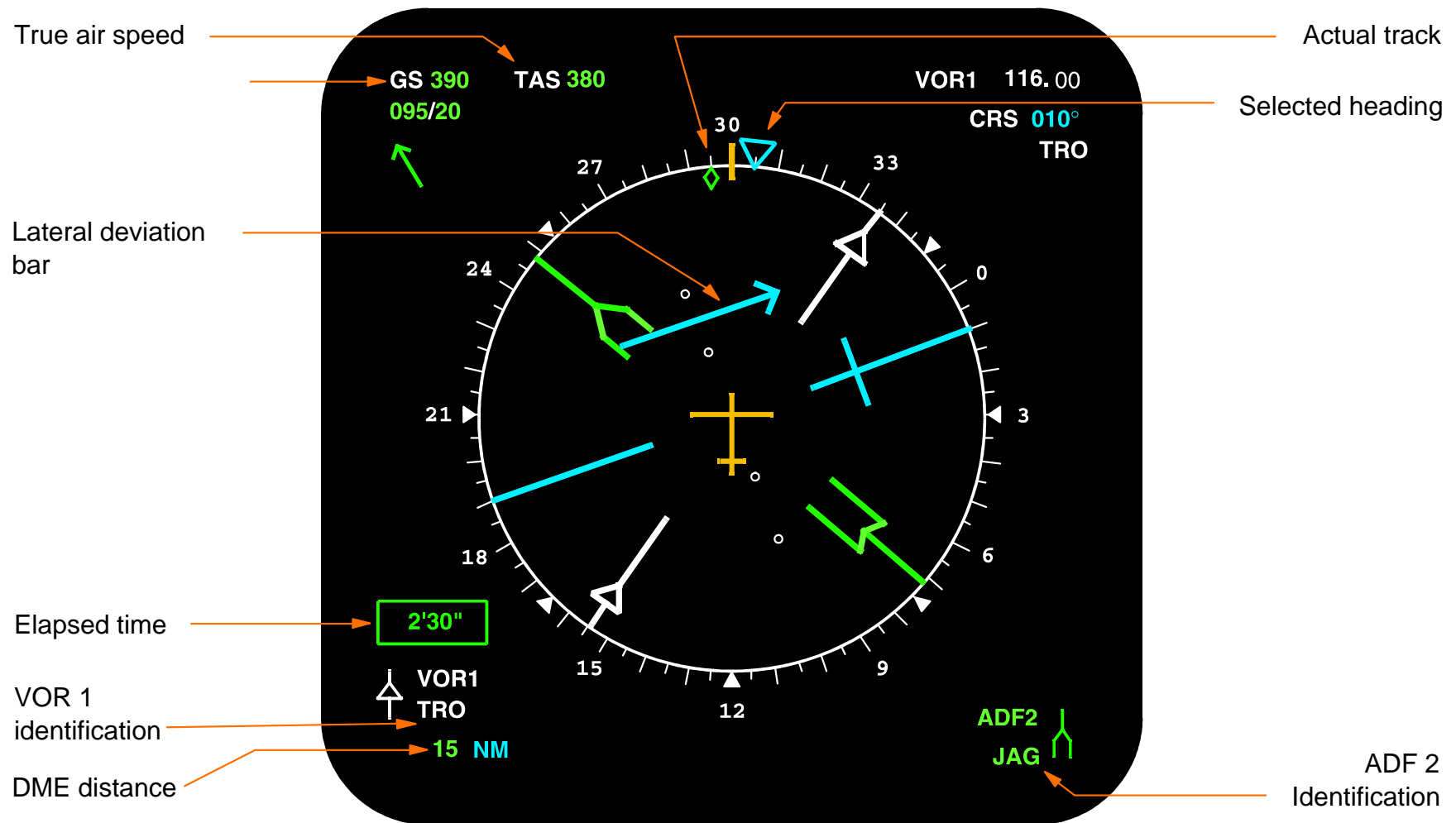

# A319/A320/A321 EIS - ND : ROSE / ILS mode

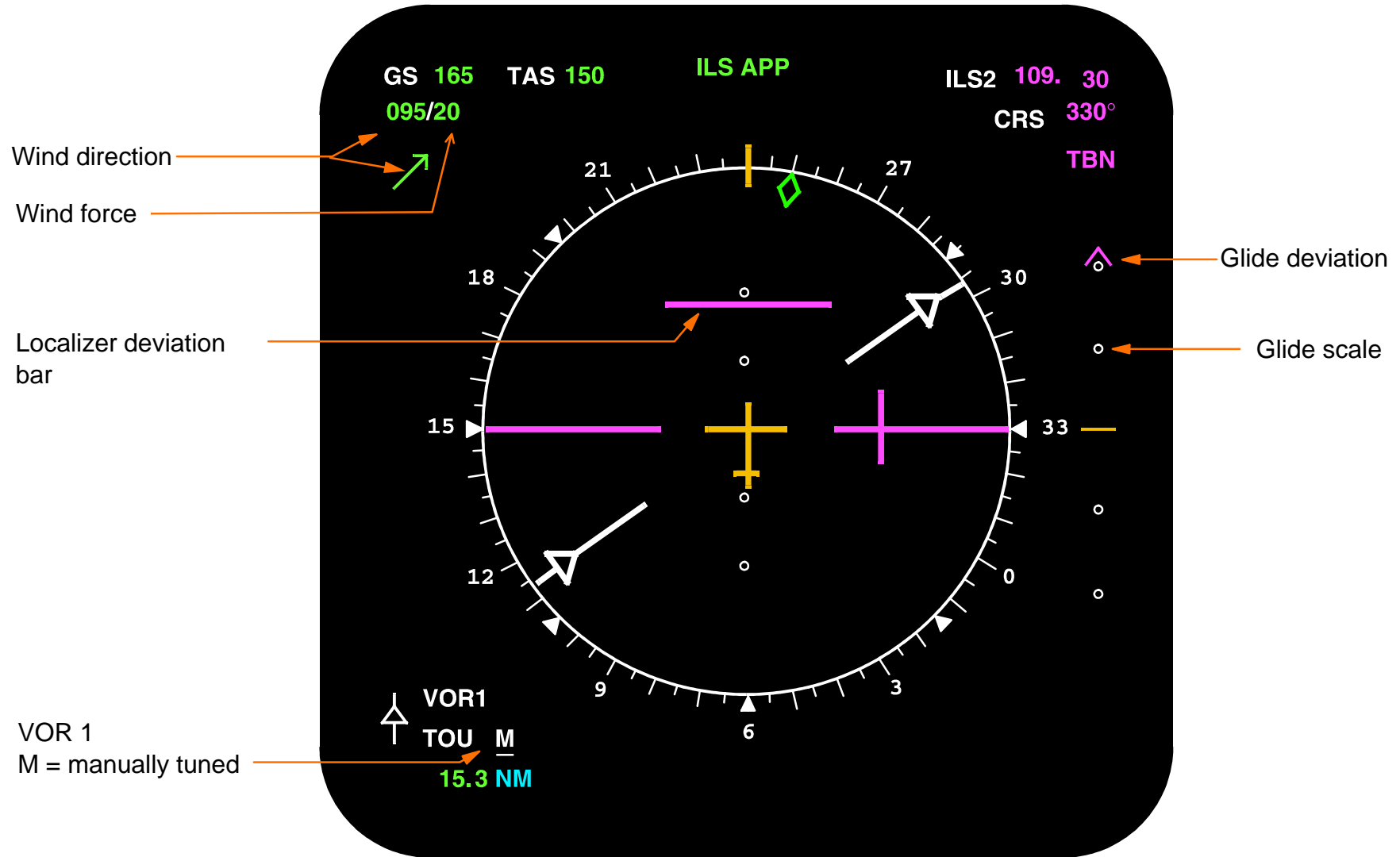

# ⊙ A319/A320/A321 EIS - ND : ROSE / NAV mode

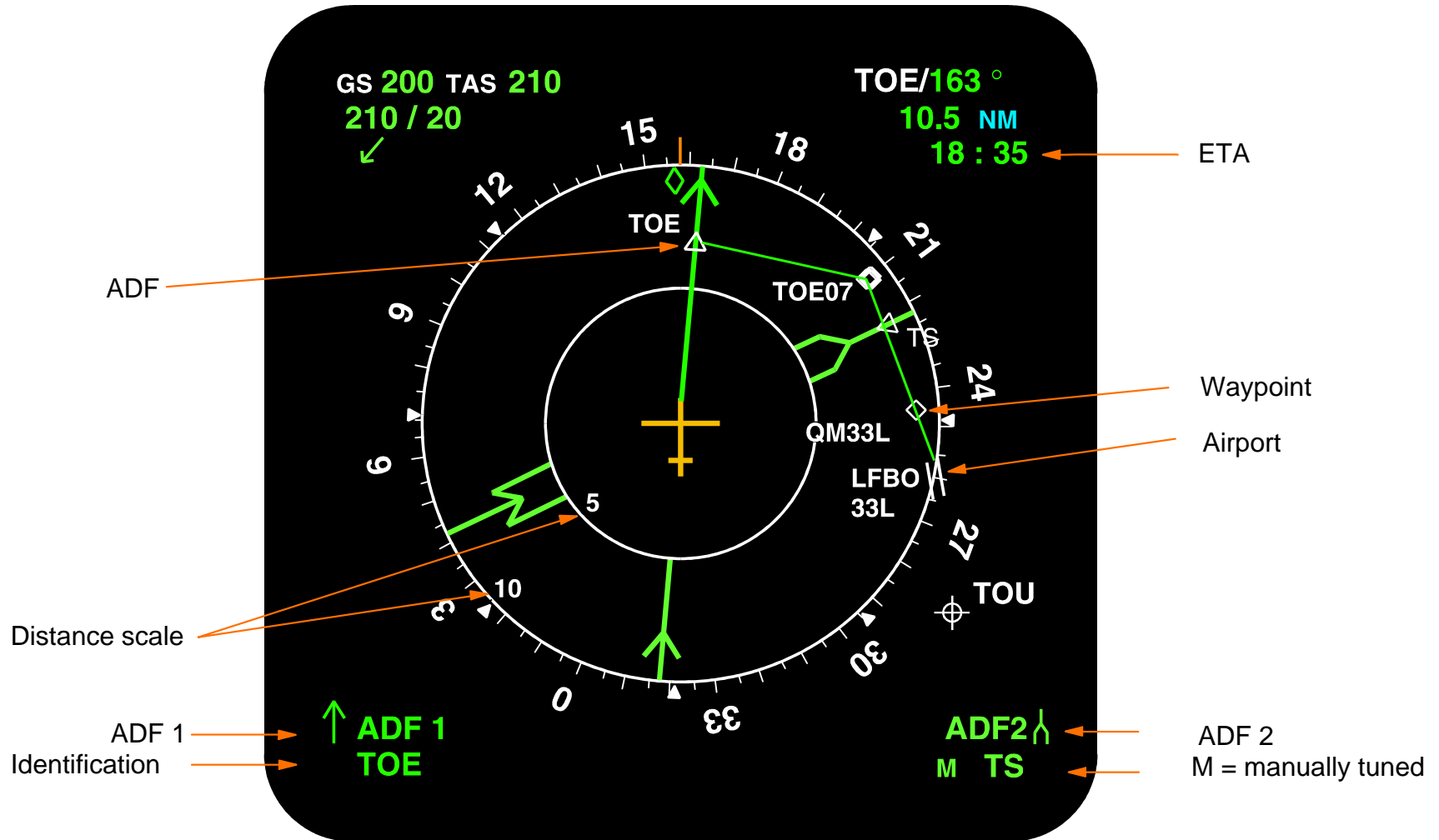

# A319/A320/A321 EIS - ND : PLAN mode

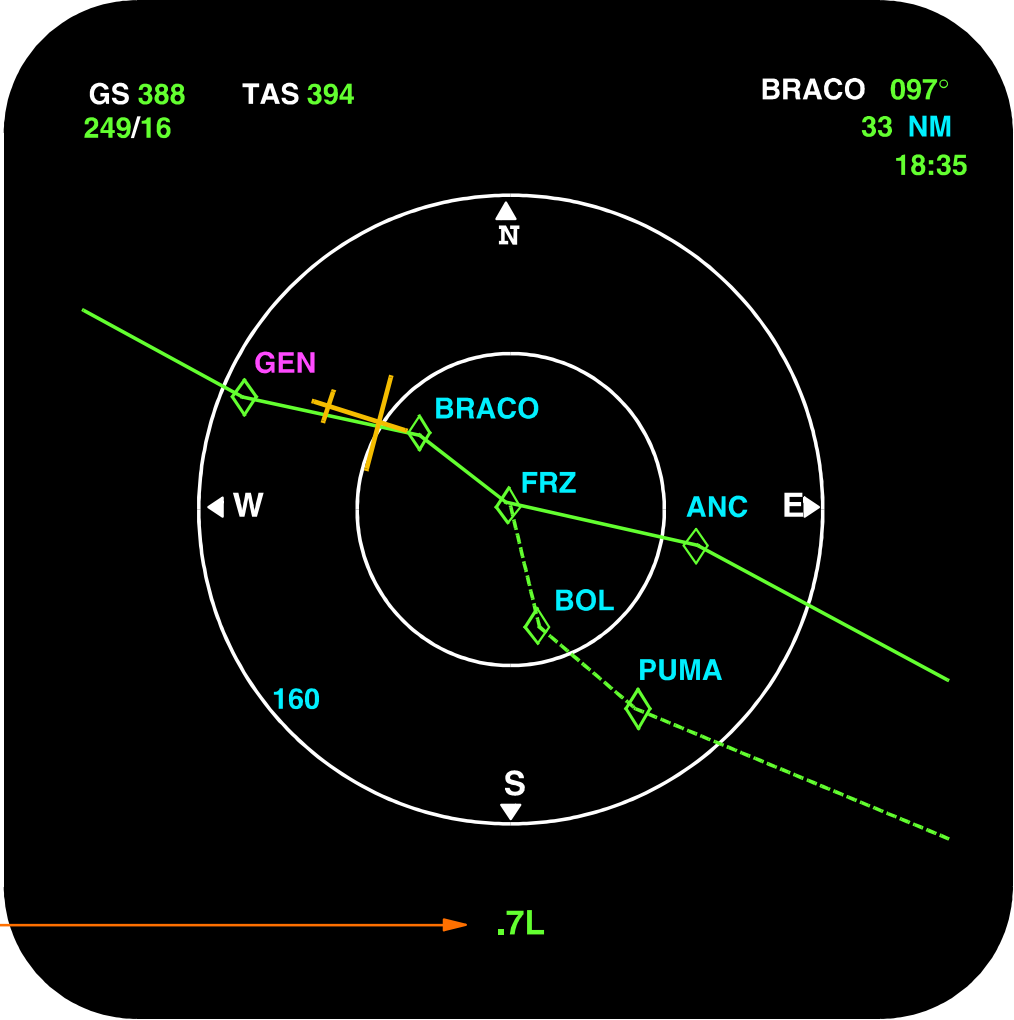

Cross track error

.7L



# **A319/A320/A321 EIS - ND : TCAS (optional)**

**Selected**  
**Range : 20 nm**

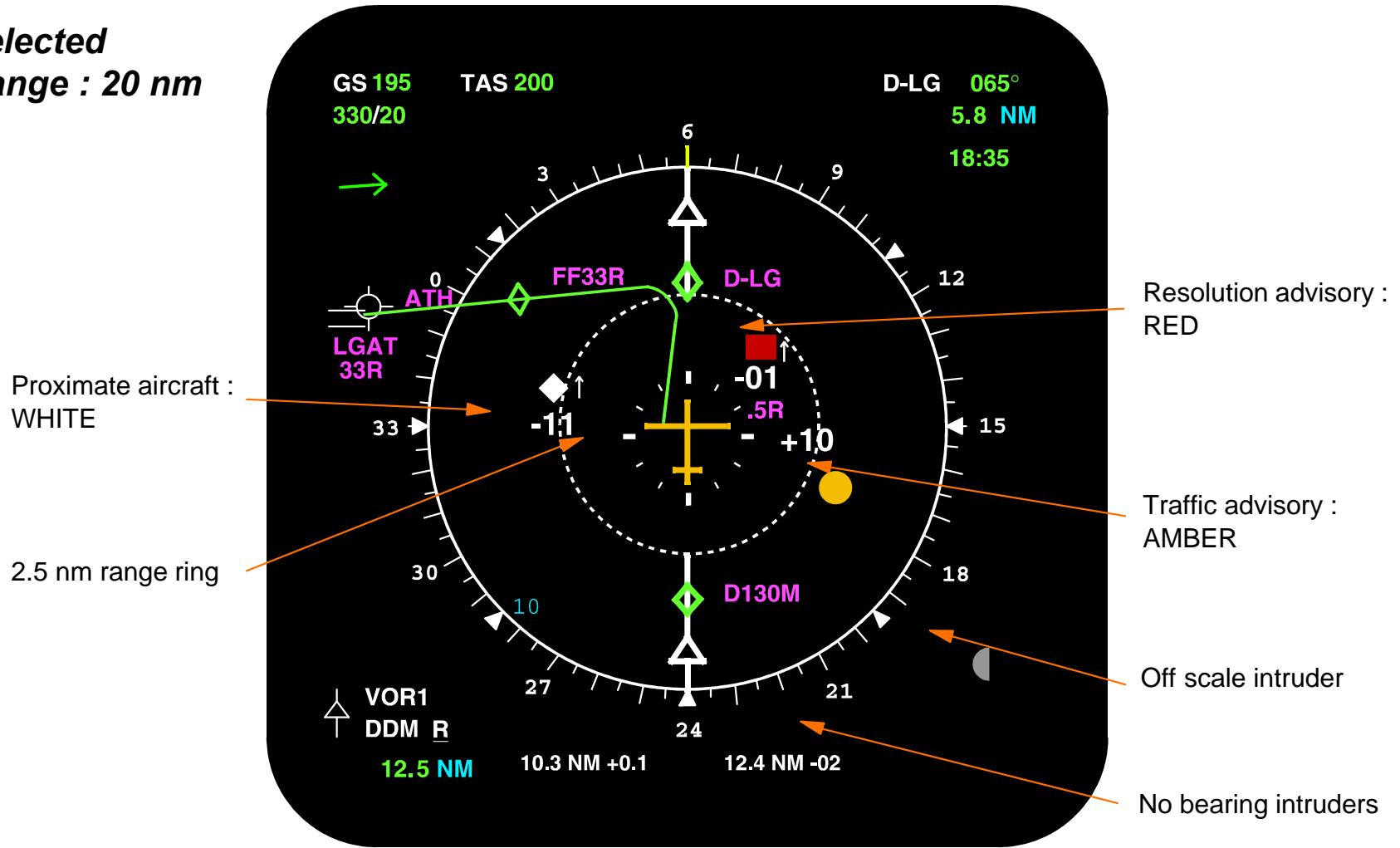

# **A319/A320/A321 EIS - ECAM arrangement**

---

- ECAM (EFIS) colour symbology

- Warnings : RED for configuration or failure needing immediate action
- Cautions : AMBER for configuration or failure needing awareness
- Indications : GREEN for normal long term operations  
WHITE for titling and guiding remarks  
BLUE for actions to be carried out  
MAGENTA for particular messages, e.g. inhibitions

- ECAM arrangement

## **Upper DU**

- Engine primary indication
- Fuel quantity information
- Slats/flaps position
- Memo/configuration data or warning/caution messages

## **Lower DU**

- Aircraft system synoptic diagram or status messages

# A319/A320/A321 EIS - ECAM arrangement

## ECAM sound Symbology

Warning signal	Condition	Duration
Continuous repetitive chime	Red warnings	Permanent
Single chime	Amber caution	1 / 2 second
Cavalry change	A/P disconnection by take-over pb	1.5 second
	A/P disconnection due to failure	Permanent
Click	Landing capability change	½ second (three pulses)
Cricket	Stall	Permanent
Intermittent buzzer	SELCAL call	Permanent
Continuous buzzer	Cabin call	Permanent
'C' chord	Altitude alert	1.5 second or Permanent
Auto call-out (synthetic voice)	Height announcement below 400ft	Permanent
Ground proximity warning (synthetic voice)	GWPS warning	Permanent

# A319/A320/A321 EIS - ECAM upper display

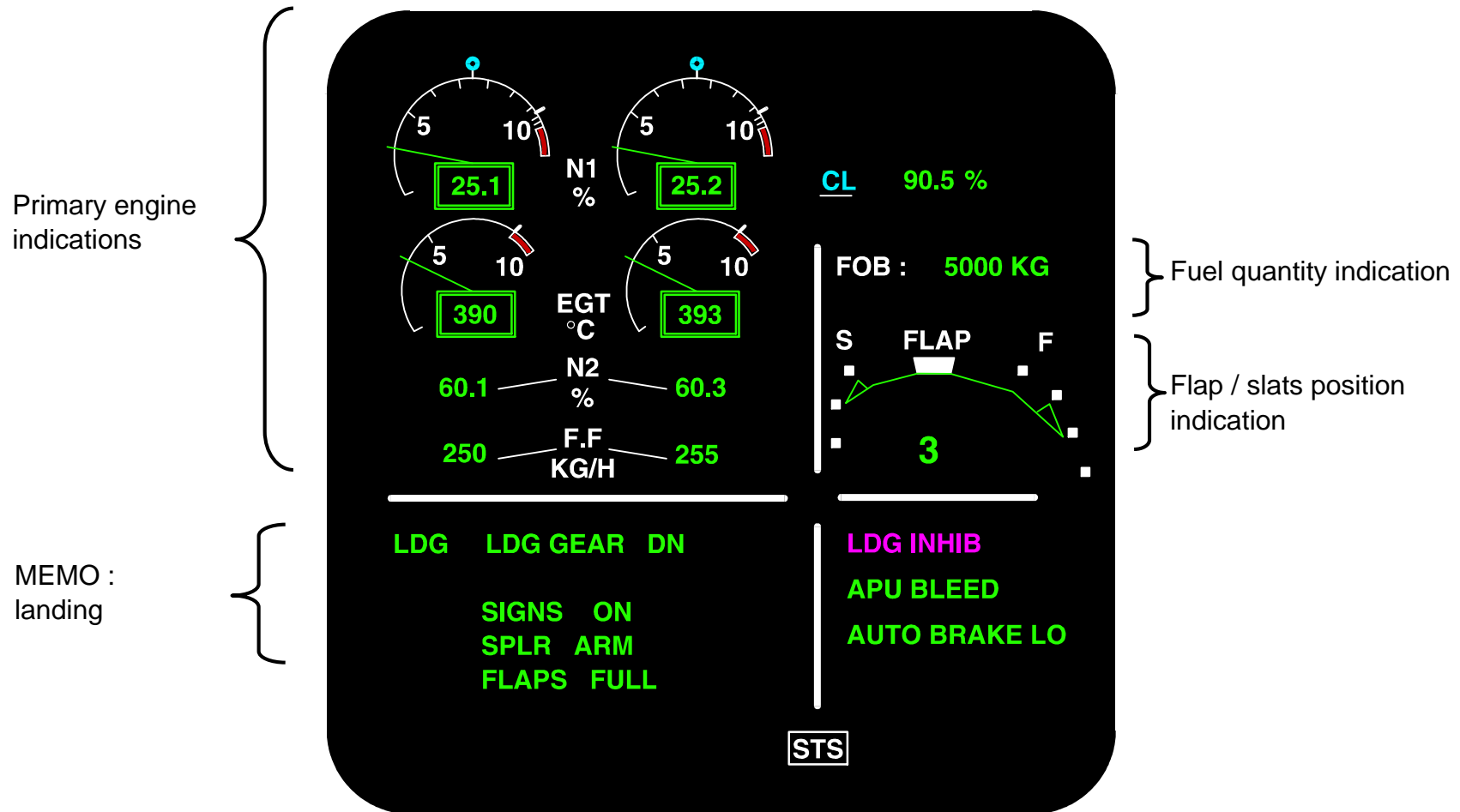

# A319/A320/A321 EIS - ECAM upper display

- The ECAM upper DU can provide the following memo items for systems which can be use temporarily and for which no dedicated annunciator lights are provided.
- Specific memos for take-off and landing are also available when appropriate.

			TO MEMO	LDG MEMO
IRS IN ALIGN X MIN	SPEED BRK	SWITCHING PNL	AUTO BRK.....MAX	LDG GEAR.....DN
IRS ALIGNED	PARK BRK	GPWS FLAP 3	SIGNS .....ON	SIGNS .....ON
SEA BELTS	HYD PTU	ACARS STBY	SPLRS .....ARM	SPLRS .....ARM
NO SMOKING	RAT OUT	MAN LDG ELEV	FLAPS .....TO	FLAPS .....FULL
REFUEL G	EMER GEN	CRT TK FEEDG	TO CONFIG ..... TEST	or
OUTR CELL FUELXFRD	RAM AIR ON	FUEL X FEED	CABIN ..... READY	CONFIG 3
STROBE LT OFF	ACARS CALL	T.O. INHIB		
N. WHEEL STEERG DISC	ACARS MSG.	LDG INHIB		
IGNITION	ENG A.ICE	LAND ASAP		
GND SPLRS ARMED	WING A.ICE			
GPWS FLAP MODE OFF	APU AVAIL	AUTO BRK {		
	APU BLEED		OFF	
	LDG LT		LO	
	BRK FAN		MED	
	AUDIO 3 X FRD		MAX	

# A319/A320/A321 EIS - ECAM lower DU

Cruise page



Electrical system page with advisory

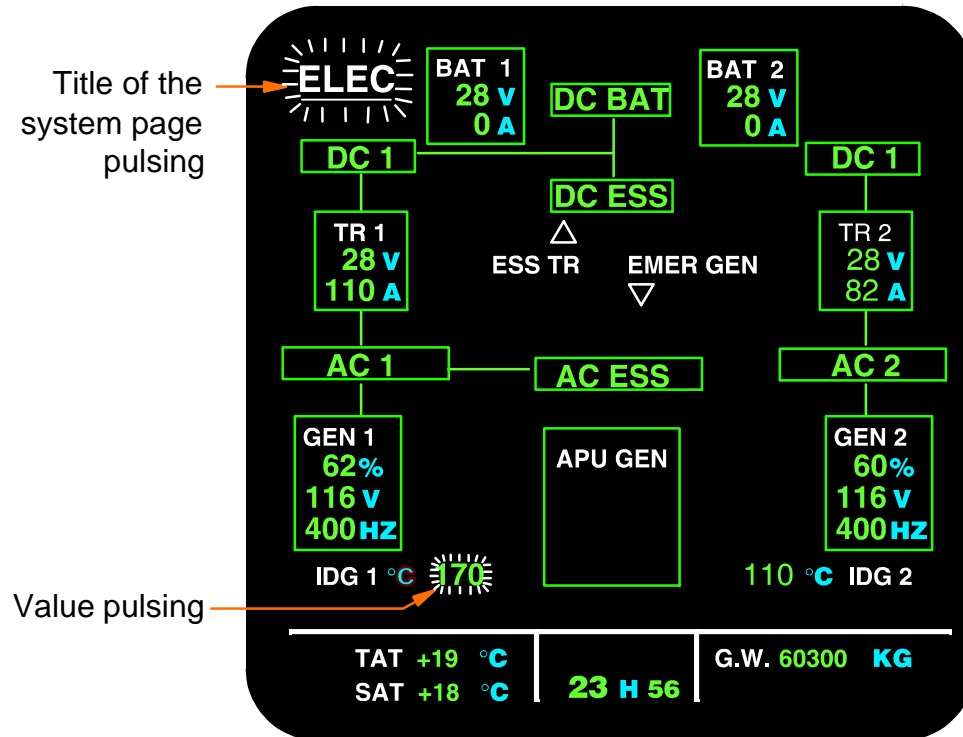

# A319/A320/A321 EIS - ECAM lower DU

---

- The ECAM lower DU presents either (one of twelve) system pages or status pages.
- Selection of **System page** is :
  - either manual from the ECAM control panel,
  - or automatic
    - in association with a warning/caution message,
    - with an advisory pulse message when a
    - parameter drifts out of range
    - according to flight phase.
- 12 available pages :

Air bleed,  
Air conditioning,  
Cabin pressurization,  
Electrical power supply – AC / DC,  
Flight controls,  
Fuel,  
Hydraulics,  
APU,  
Engine monitoring,  
Doors / oxygen,  
Braking (wheel, ground spoiler),  
Cruise.

# A319/A320/A321 EIS - ECAM system pages

### Cruise page



### Engine page

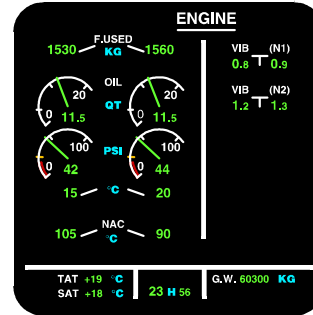

### Air bleed page

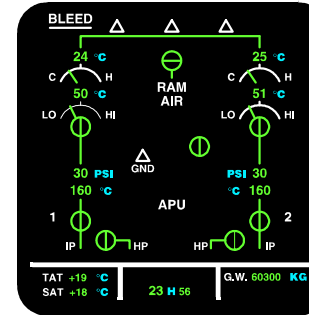

### Cabin pressurization page

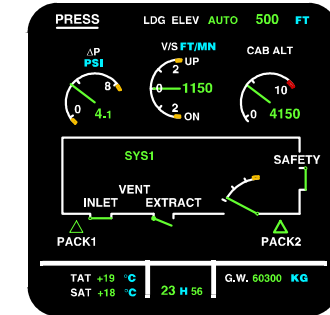

### Electric page

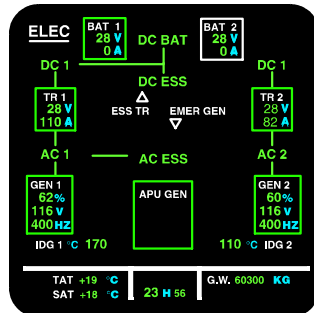

### Hydraulic page

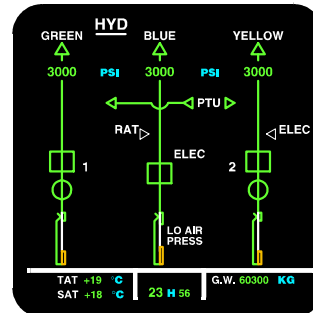

### Fuel page

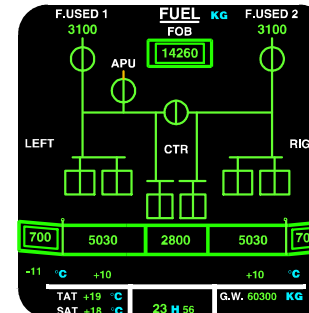

### APU page

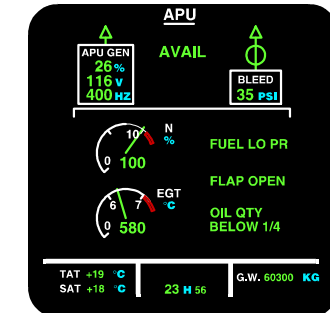

### Air conditioning page

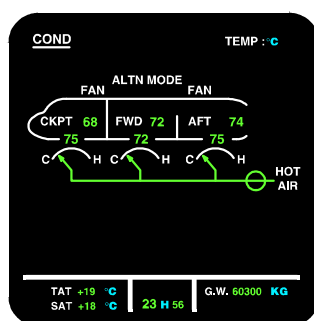

### Doors/oxygen page

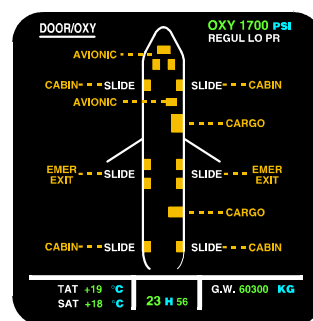

### Wheel page

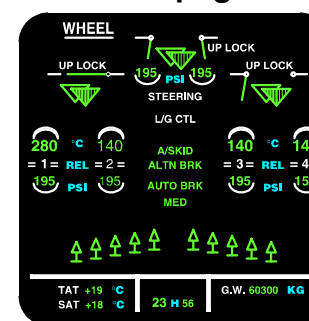

### Flight controls page

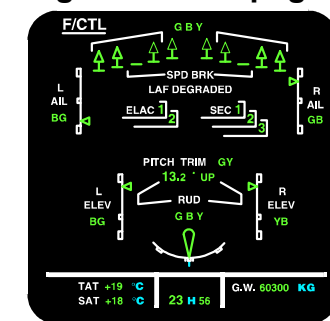



# A319/A320/A321 EIS - ECAM lower display – auto flight phase

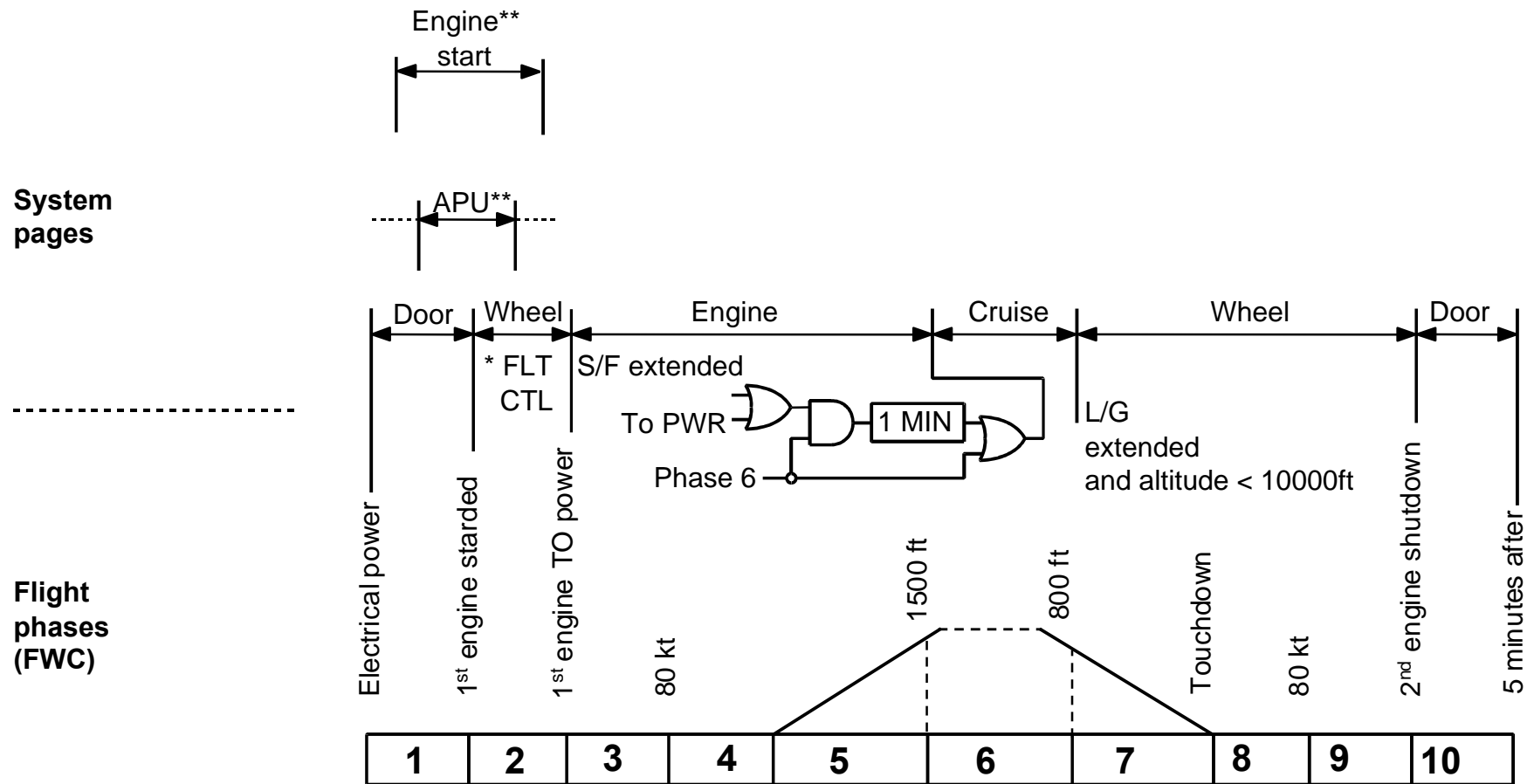

\* FLT CTL page replaces wheel page for 20 seconds when either sidestick is moved or when rudder deflection is above 22°.

\*\* APU page or EBG START page automatically displayed during start sequence.



# A319/A320/A321 EIS – ECAM lower display

## Status page

The operational summary of the aircraft status after a failure is displayed on the lower ECAM DU and includes :

- (a) Postponable procedures not displayed on first page (blue)
- (b) Limitations (speed, flight level...) (blue)
- (c) Informations (green)
- (d) Cancelled cautions or warnings (white)
- (e) Inoperative systems (amber)
- (f) Maintenance status (white)

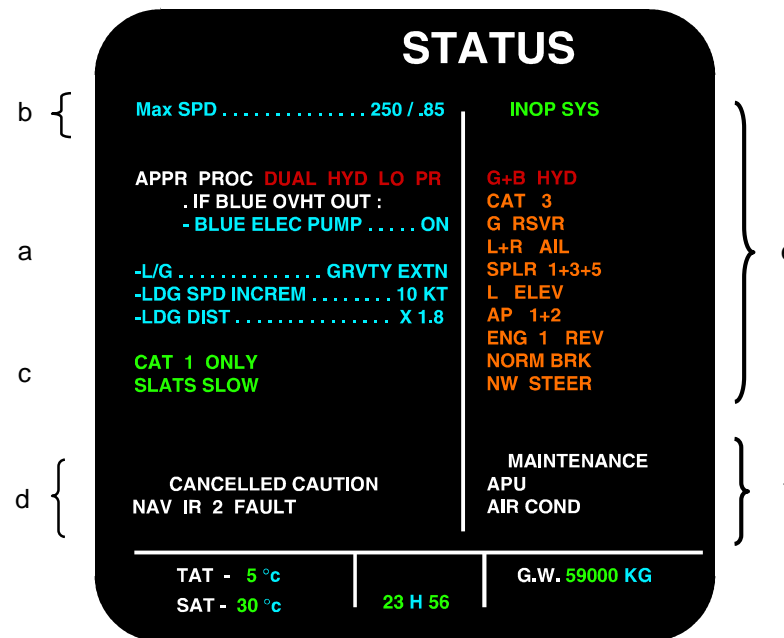

# A319/A320/A321 EIS – ECAM control / switching panels



} System page control

# A319/A320/A321 EIS – Dus reconfiguration

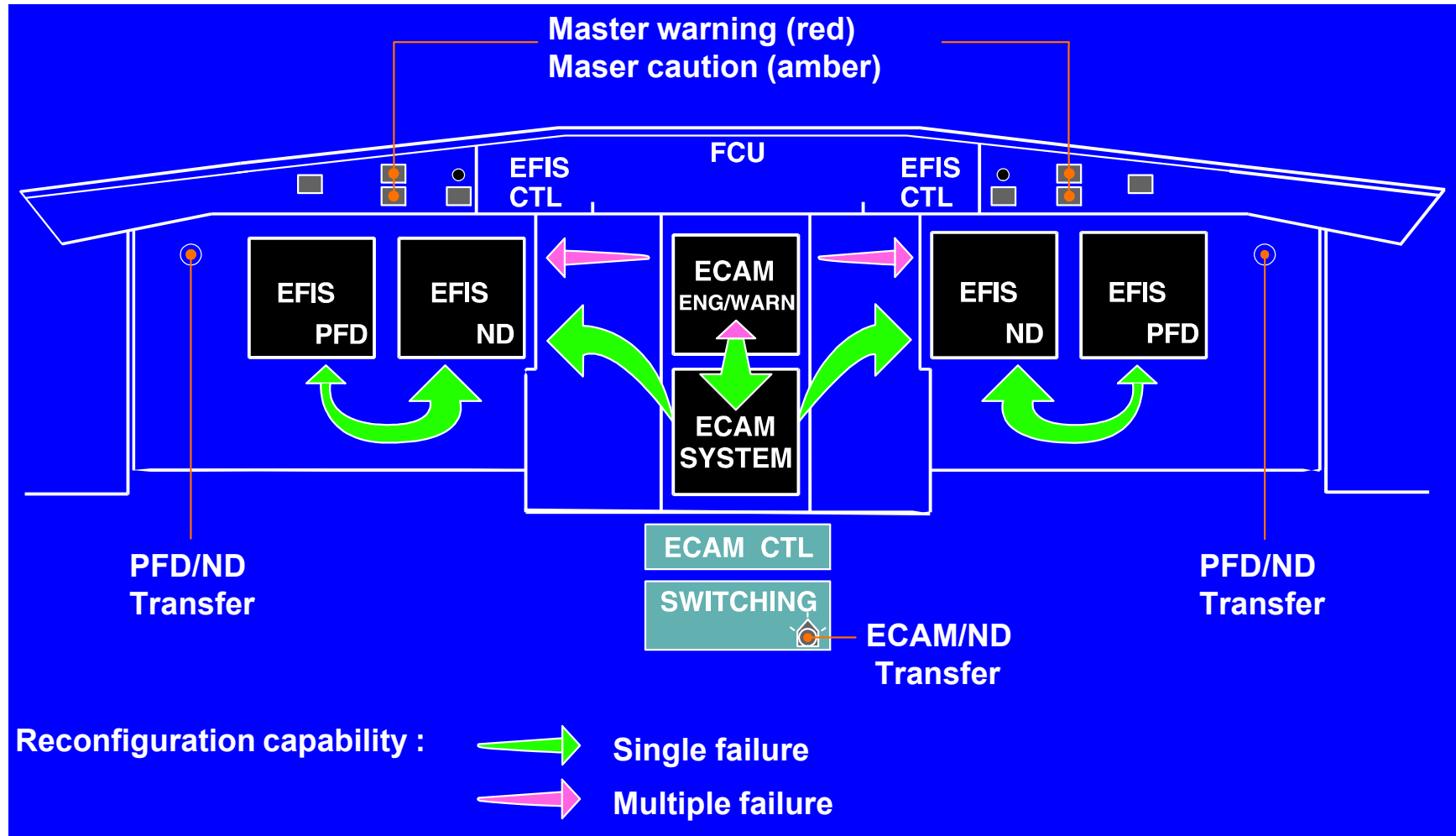



Independent failure  
presentation sequence

Example : electrical generator fault





# A320 EIS – independent failure : initiation

The following displays appear, provided no flight phase inhibition is active.

ECAM upper display

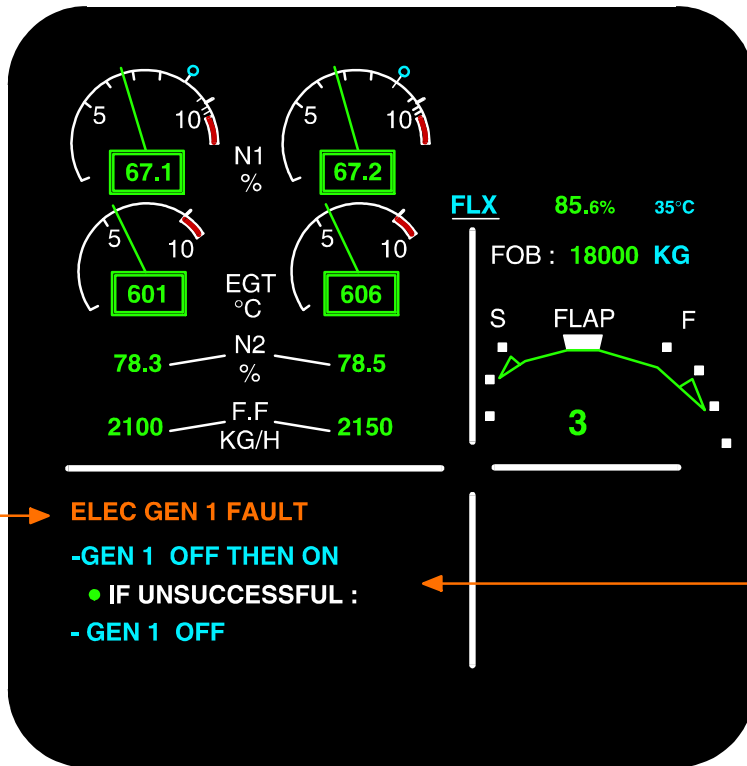

Failure identification

Corrective actions

ECAM lower display : ELEC page

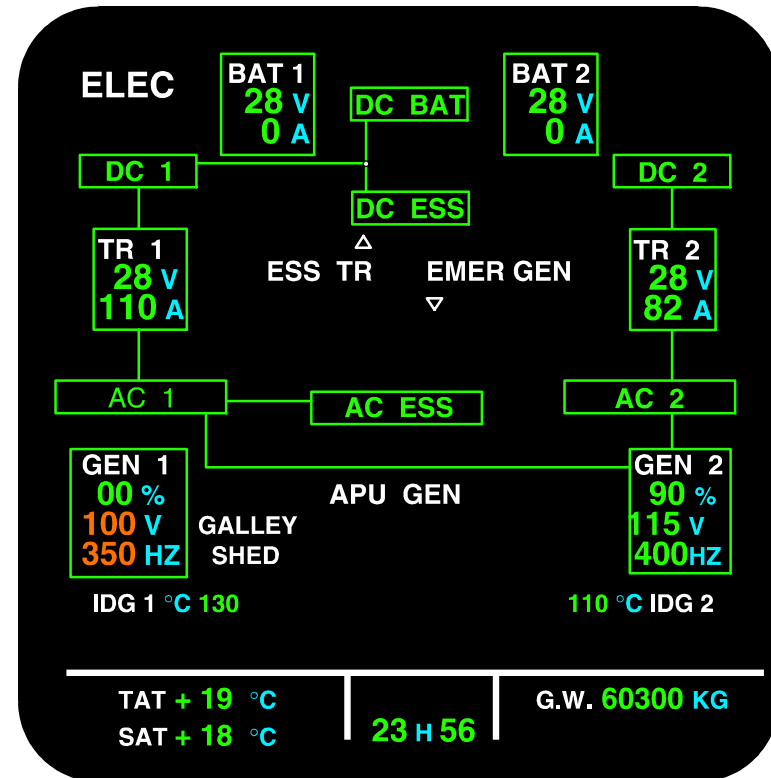

The corresponding system page appears automatically

# A319/A320/A321 EIS – independent failure : after corrective action

ECAM upper display

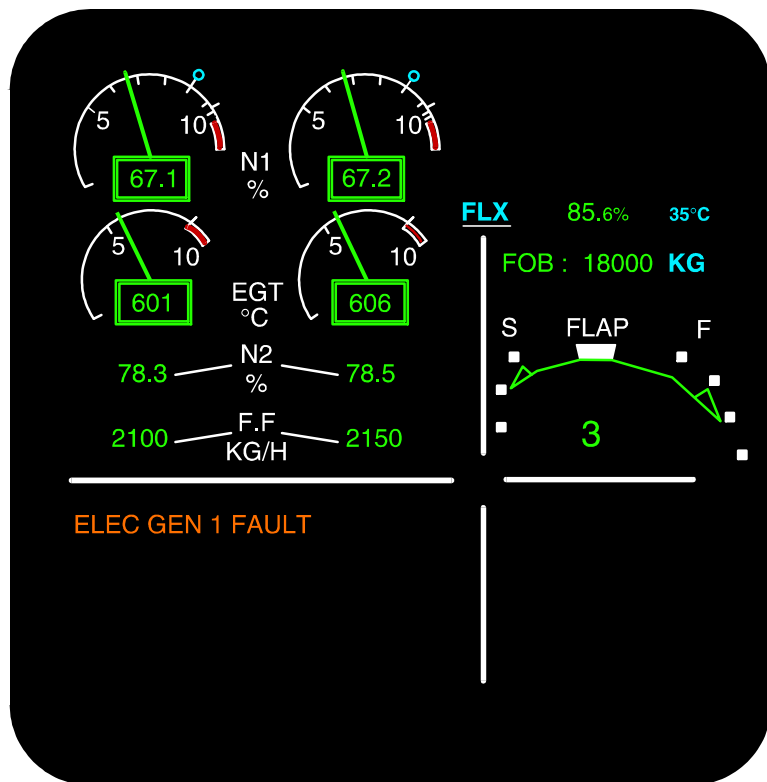

Actions lines automatically cleared when corresponding actions performed

ECAM lower display : ELEC page

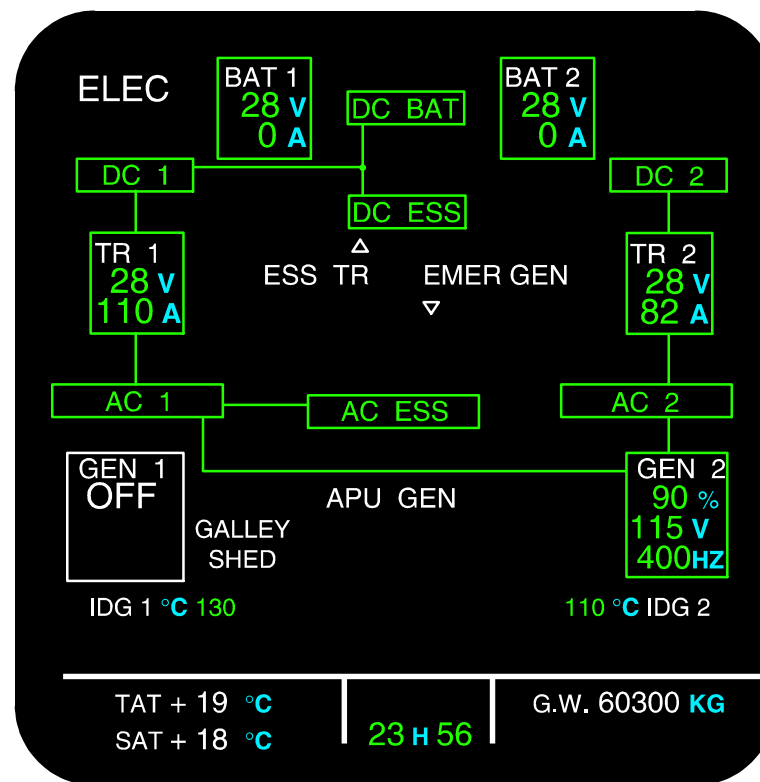

ELEC page changes according to the corrective action

# A319/A320/A321 EIS – independent failure : after “clear” action

### ECAM upper display

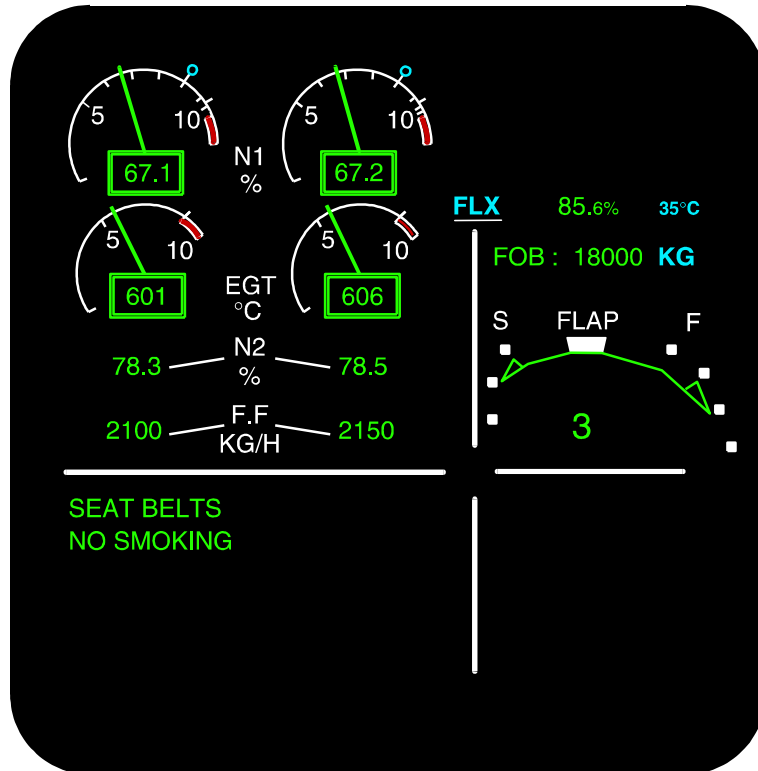

- Warning message is cleared
- Memo comes back

### ECAM lower display

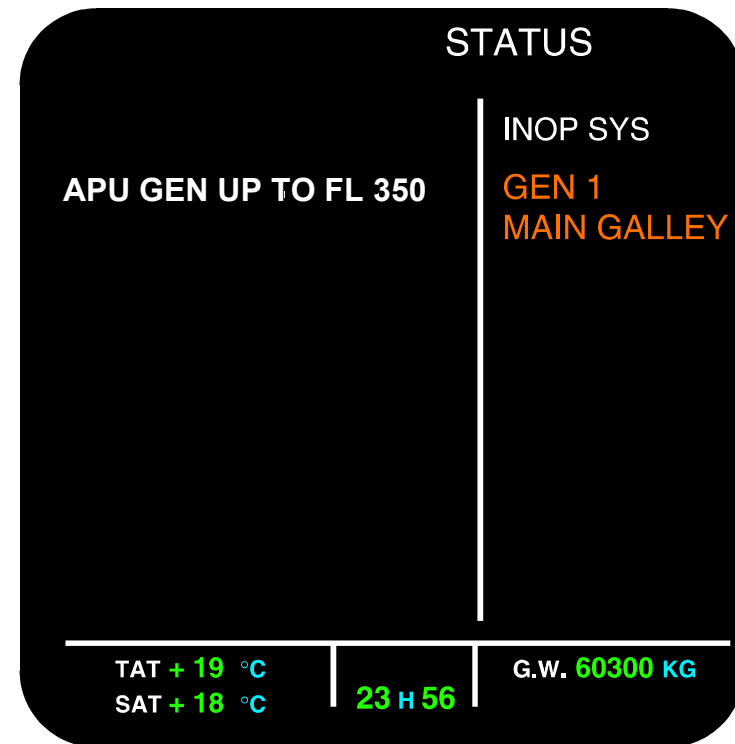

- Status page appears automatically
- When “clear” button is pressed again flight phase system page comes back



## Primary / secondary failure presentation sequence

Example : Blue hydraulic reservoir low air pressure  
corrective action leading to primary  
failure : Blue hydraulic system low  
pressure



# A319/A320/A321 – EIS – primary / secondary failure : initiation

1<sup>st</sup> step : independent failure detection

Upper display

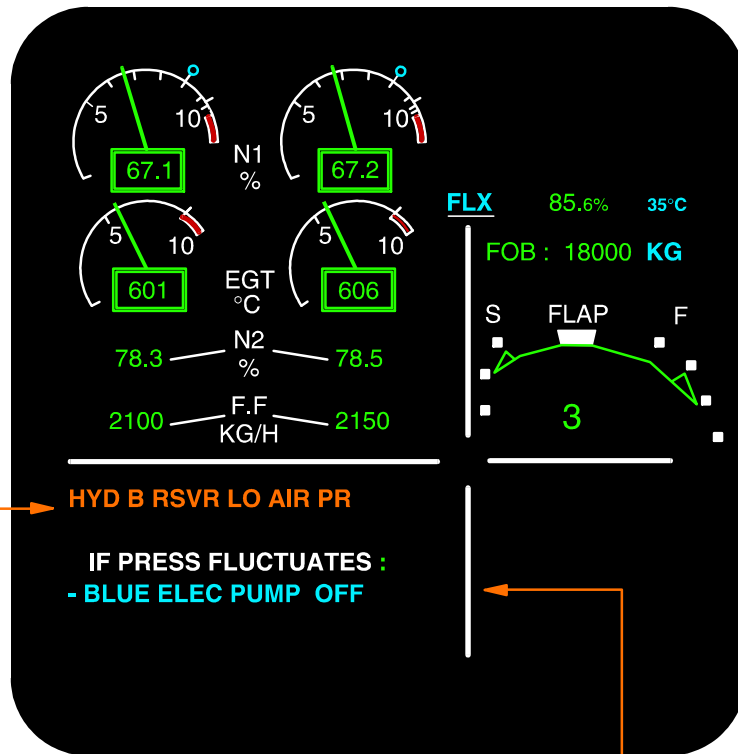

Failure identification

Corrective action

Lower display : HYD page

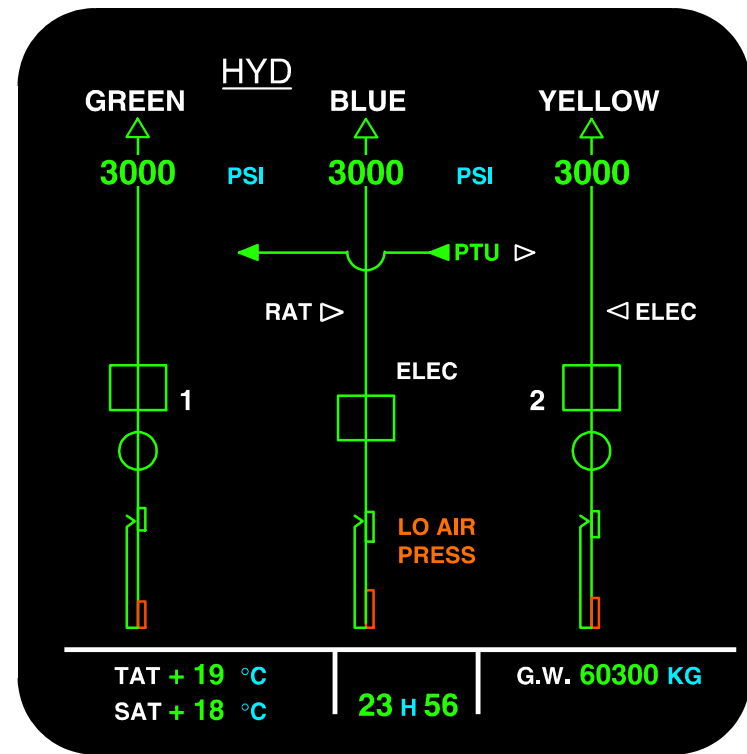

The corresponding system page appears automatically

# A320 – primary / secondary failure : after corrective action

2<sup>st</sup> step : after performing the corrective action

Upper display

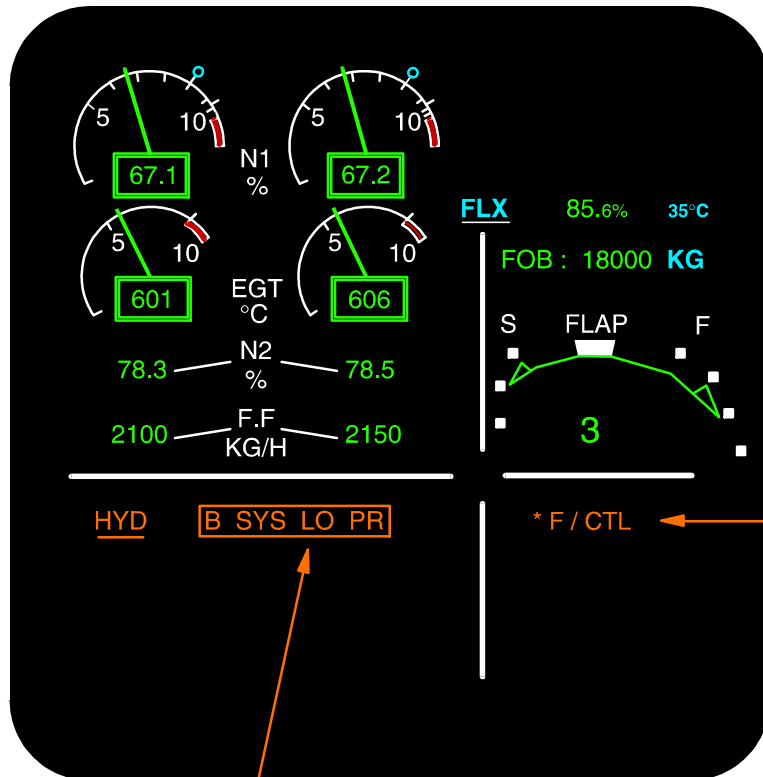

Display of resulting primary failure

Resulting secondary failure is displayed

Lower display : HYD page

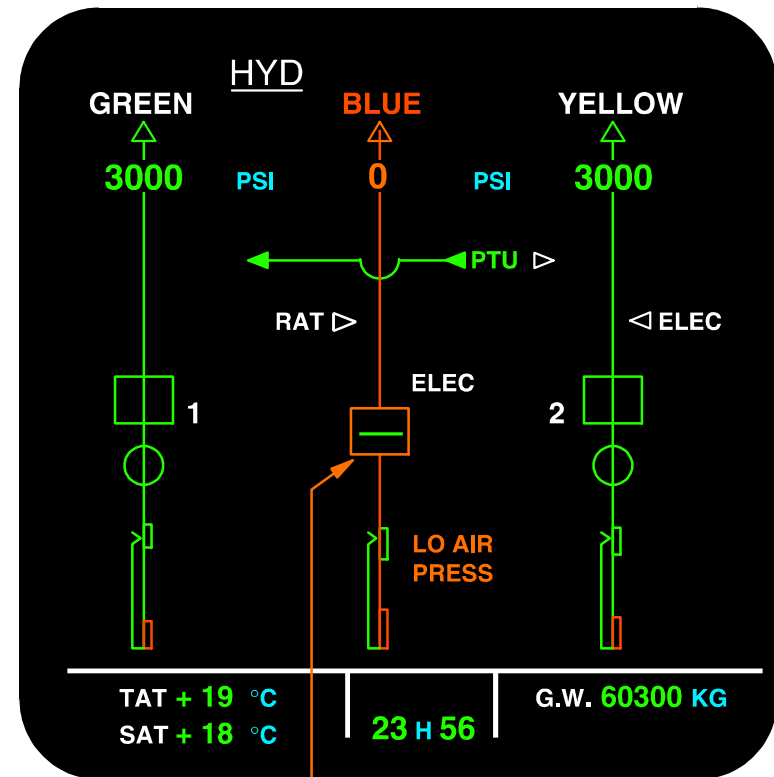

The corresponding system page is automatically updated





# A319/A320/A321 EIS – primary / secondary failure : after “clear” actions 2

## 4<sup>th</sup> step : second “CLEAR”

Upper display

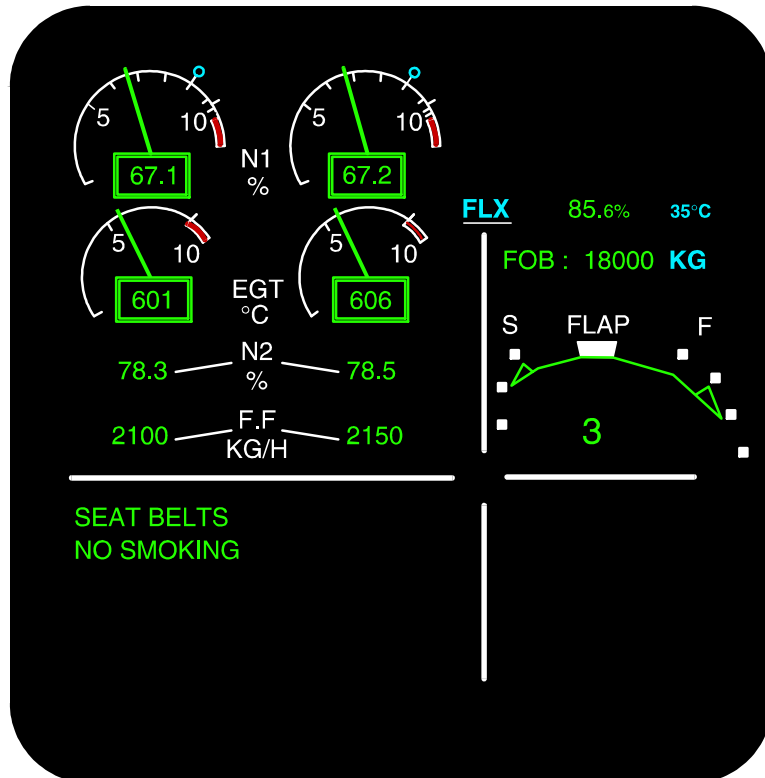

Lower display : status page

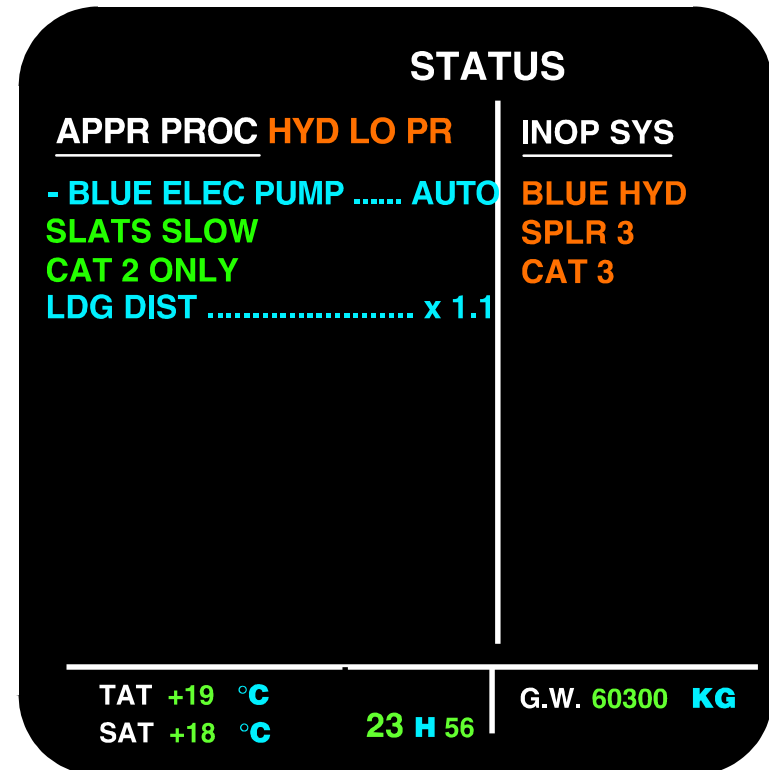

- Status page appears automatically after second “clear”

# A319/A320/A321 EIS – primary / secondary failure : after “clear” actions 3

## 5<sup>th</sup> step : third “CLEAR”

Upper display

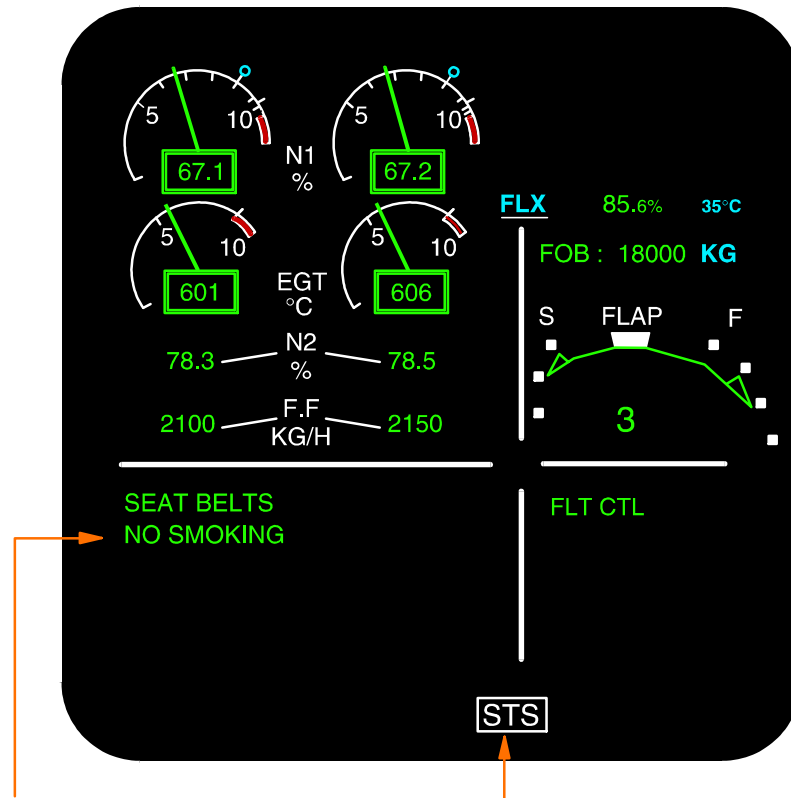

Display of entire memo

Status reminder

Lower display : cruise page

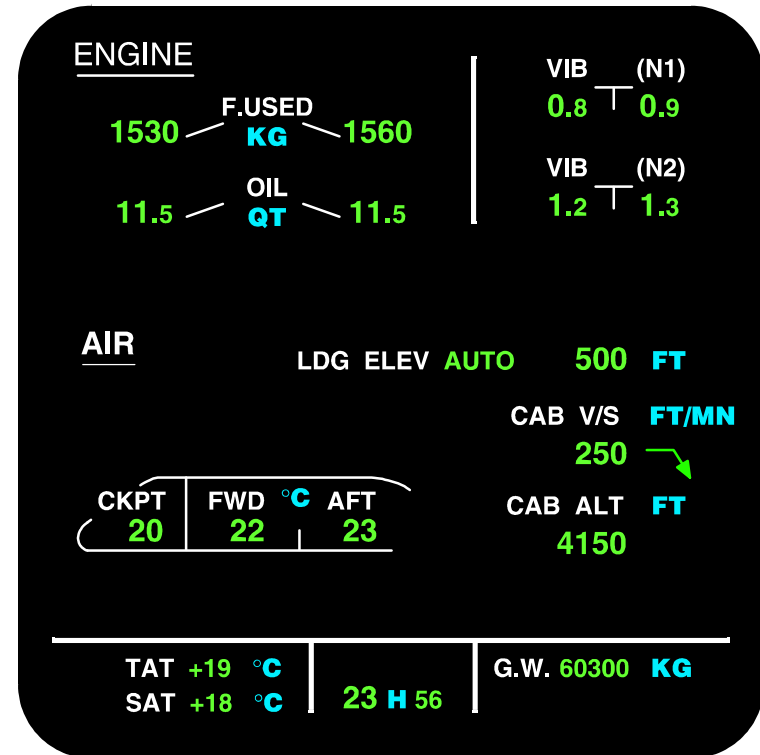

- When “clear” button is pressed for the third consecutive time, flight phase system page comes back





---

# **13. Radio management and communication**

# A319/A320/A321 radio management concept

## Radio Management Panel (RMP)

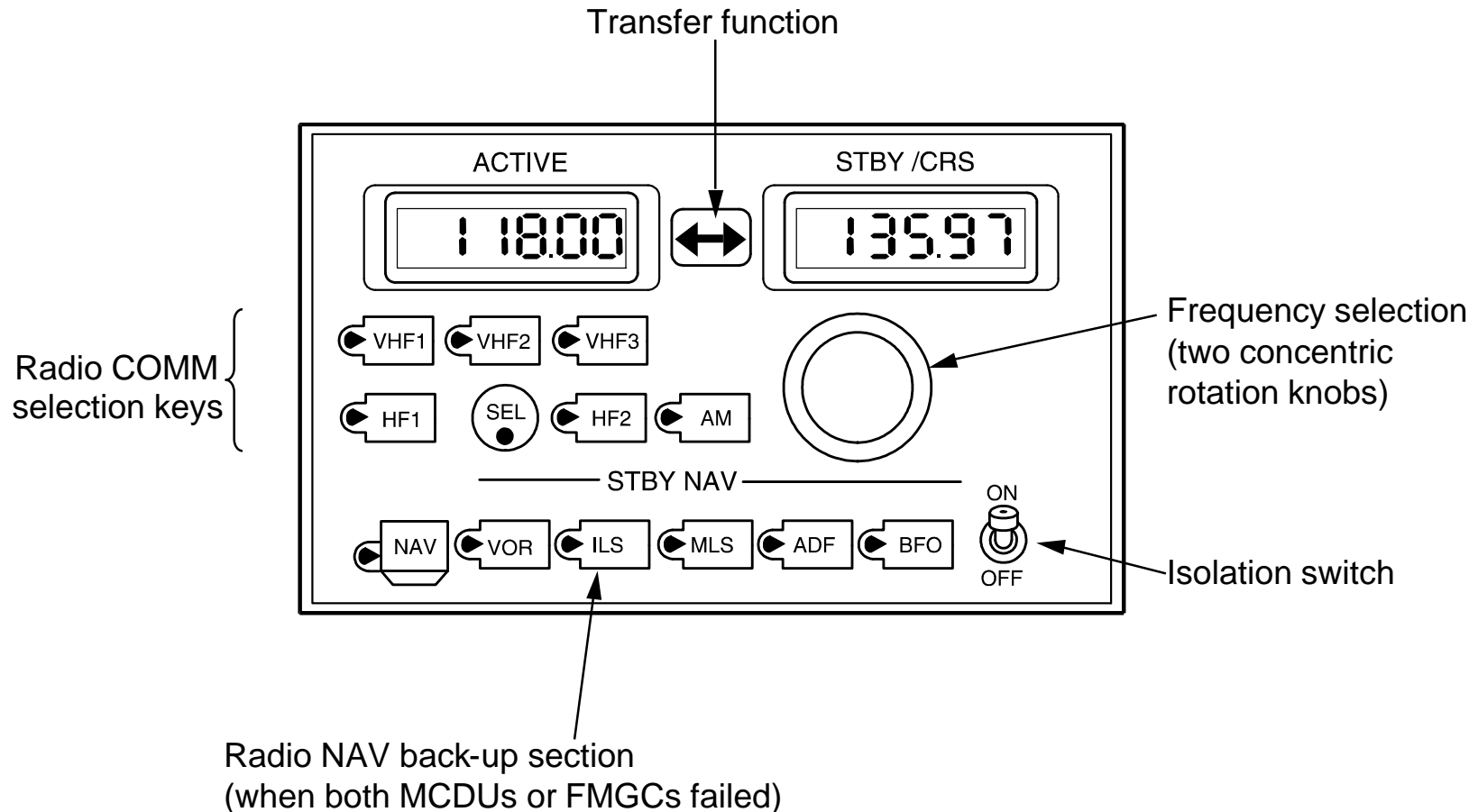

# **A319/A320/A321 radio management concept**

---

- Radio Management Panel (**RMP**) system provides :
  - crew control of all radio communication systems
  - back-up of the two FMGCs for controlling all radio navigation systems
  
- Basic installation includes :
  - two RMPs on pedestal
  - full provision for installation of a third RMP on overhead panel
  
- The ATC transponder is tuned by a separate conventional control panel.

# A319/A320/A321 RMP architecture

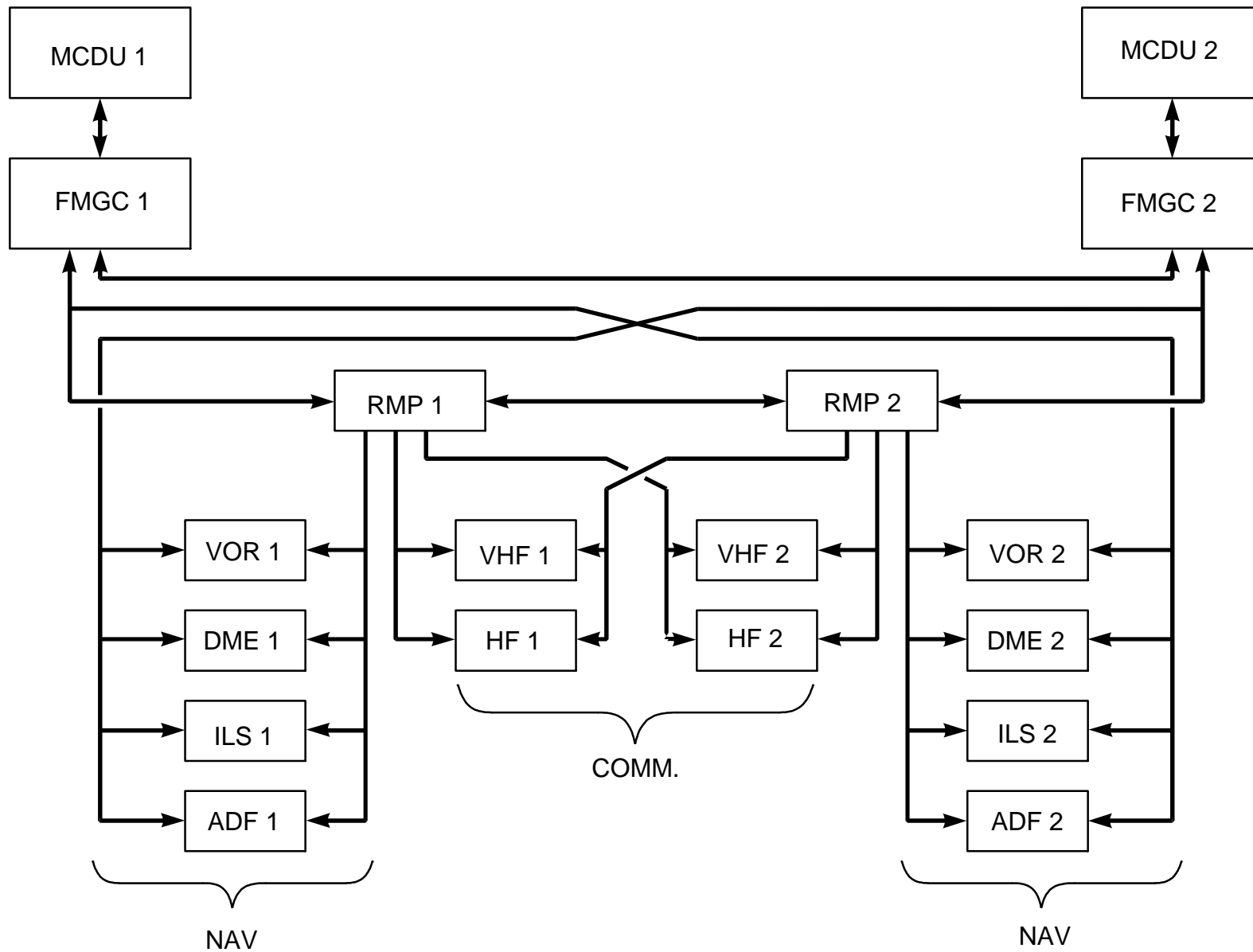



# **A319/A320/A321 radio management concept architecture**

---

## **Communication tuning**

Any radio communication system can be tuned from any of two RMPs. In case of failure any RMP can take over from the other one.

## **Navigation tuning**

Three different operating modes exist.

- **Automatic** : VOR/DME, ILS and ADF are automatically tuning controlled by the FMGS.
- **Manual tuning** : for selection if a specific frequency through the FMGS CDU without affecting the automatic function of the FMGS.
- **Back-up tuning** : when both FMGCs are inoperative or when an emergency electrical source is in operation, any NAV receiver may be tuned by the crew from any RMP ; each RMP controls on side receivers.

When one of both FMGCs is inoperative, the remaining one controls all receivers.

# A319/A320/A321 COMM – audio control panel

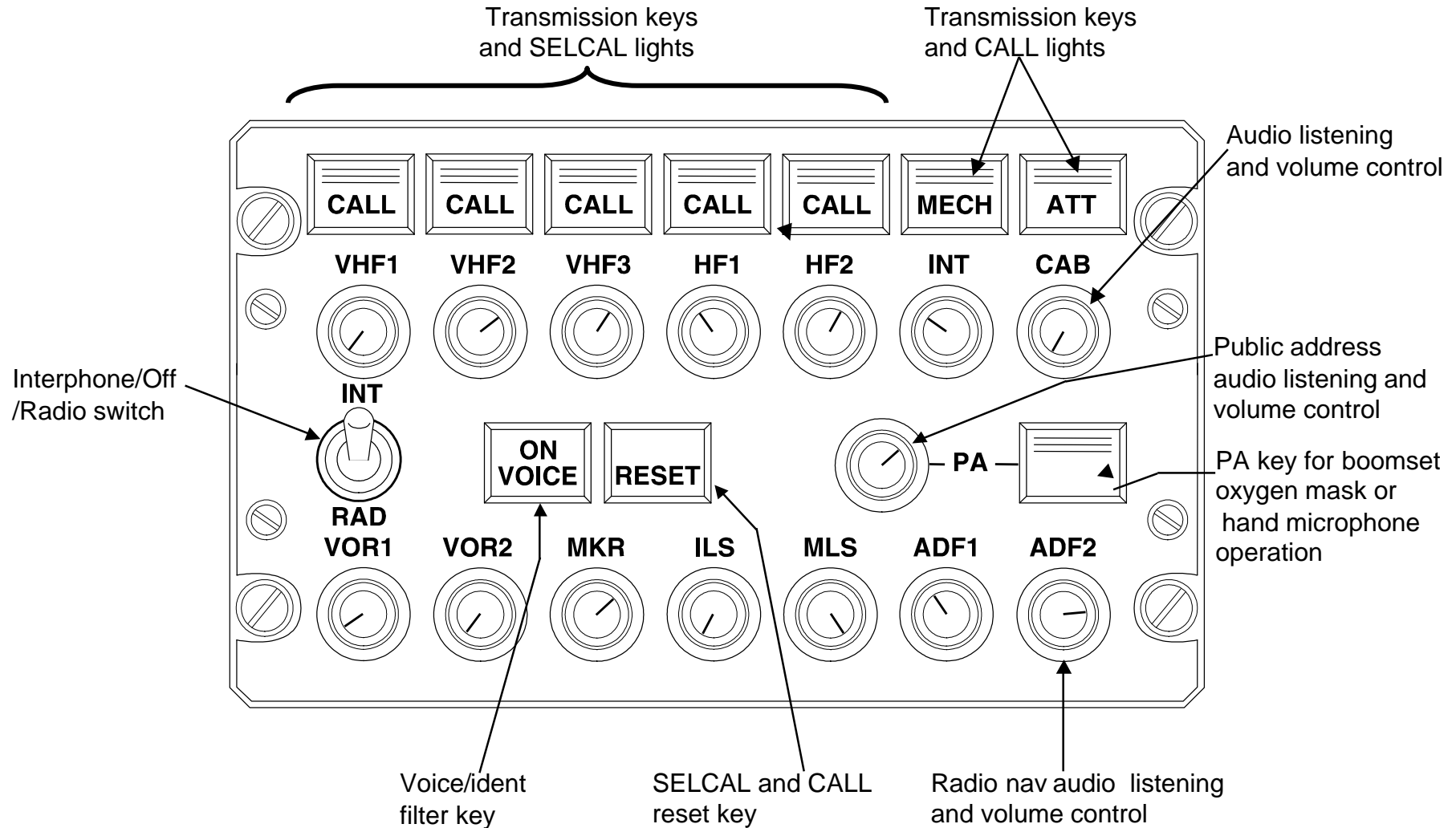

# **A319/A320/A321 COMM – audio control panel**

---

The audio integrating system provides the management of all audio signals produced by and feeding the radio-communications, radio navigation and interphone systems :

- Basic installation includes :
  - three Audio Control Panel (**ACP**) – two on pedestal, one on overhead panel
  - one Audio Management Unit (**AMU**) in avionics bay
  - one **SELCAL** code selector in avionics bay.
- Provision exists for supplementary ACP's
- All selections and volume adjustments carried out by crew through ACPs
- All ACPs are fitted for maximum capacity (three VHF, two HF, public address, calls, two VOR, two ADF, ILS and provision for MLS).
- Each ACP and associated AMU electronic card are fully independent and microprocessor controlled.





---

# **14. Maintenancecentralized fault displaysystem**



# **A319/A320/A321 Centralized Fault Display System (CFDS)**

---

## **General**

Line maintenance of the electronic systems is based on the used of a Centralized Fault Display System (**CFDS**).

The purpose of the CFDS is to give maintenance technicians a central maintenance aid to intervene at system or subsystem level from multipurpose CDUs located in the cockpit :

- to read the maintenance information
- to initiate various tests.

Two levels of maintenance should be possible using the CFDS :

- maintenance at an out-station (LRU change)
- maintenance in the hangar or at the main base (troubleshooting).

# A319/A320/A321 CFDS - architecture

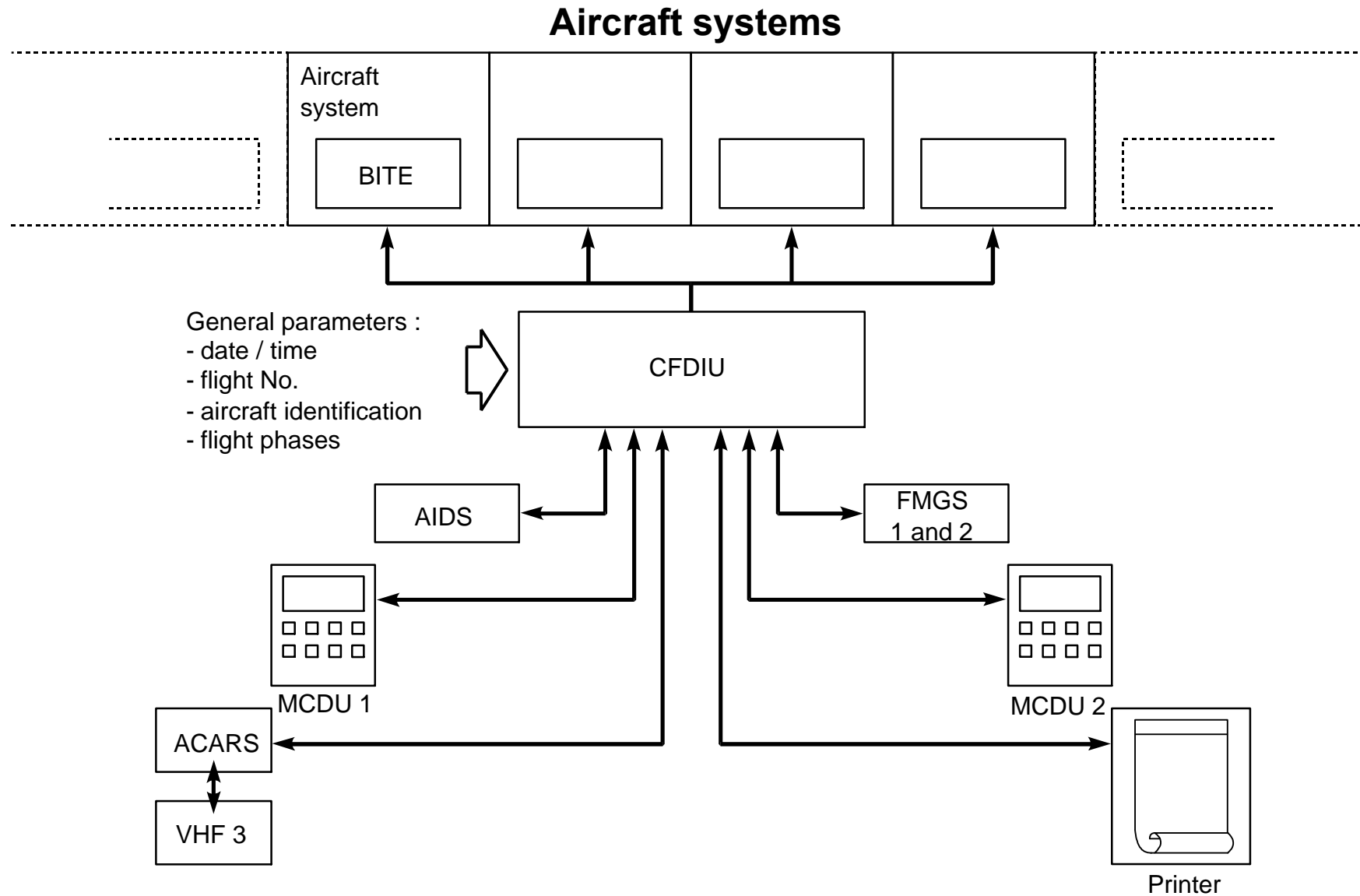



# **A319/A320/A321 CFDS - architecture**

---

## **Advantages of the CFDS**

A revised maintenance concept provides a :

- reduction of the duration of operations
- reduction of the maintenance crew training time
- simplification of technical documentation
- standardization of the equipment
- simplification of the computers which no longer display any BITE ;

## **Integration of the CFDS**

Integrated in the Maintenance and Recording Data System (**MRDS**) comprising :

- Basic equipment
  - A Centralized Fault Display Interface Unit (**CFDIU**)
  - A digital Flight Data Recorder (**DFDR**) and its interface unit
  - Two multipurpose CDUs (**MCDUS**) located on the pedestal.

Note : The MCDUS can be used for : FMS, MRDS options (ACARS, AIDS).

- Optional equipment

- A multi-use printer
- A quick access recorder (**QAR**)
- An **AIDS**

# A319/A320/A321 CFDS – example of use - 1

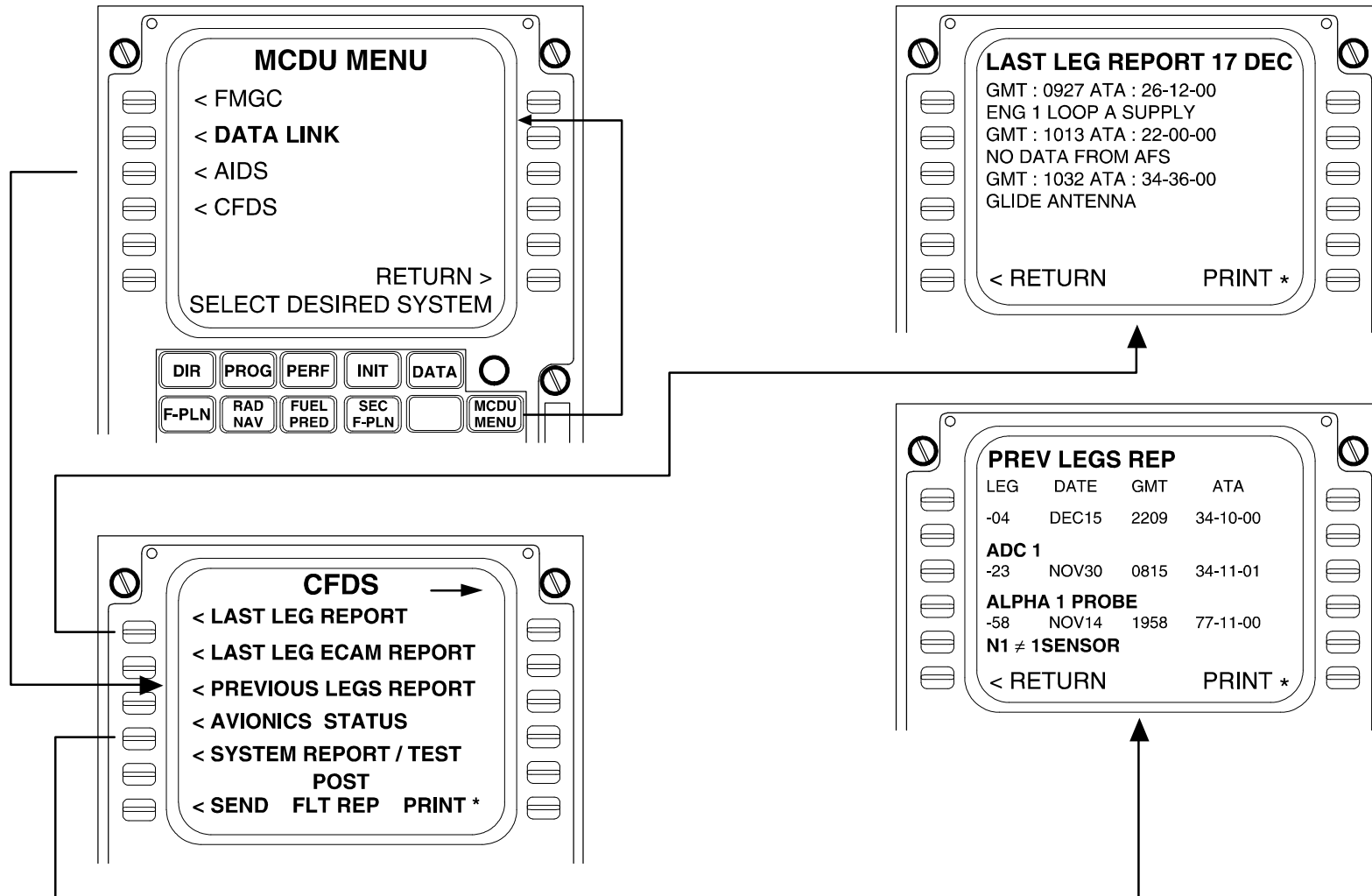

# A319/A320/A321 CFDS – example of use - 2

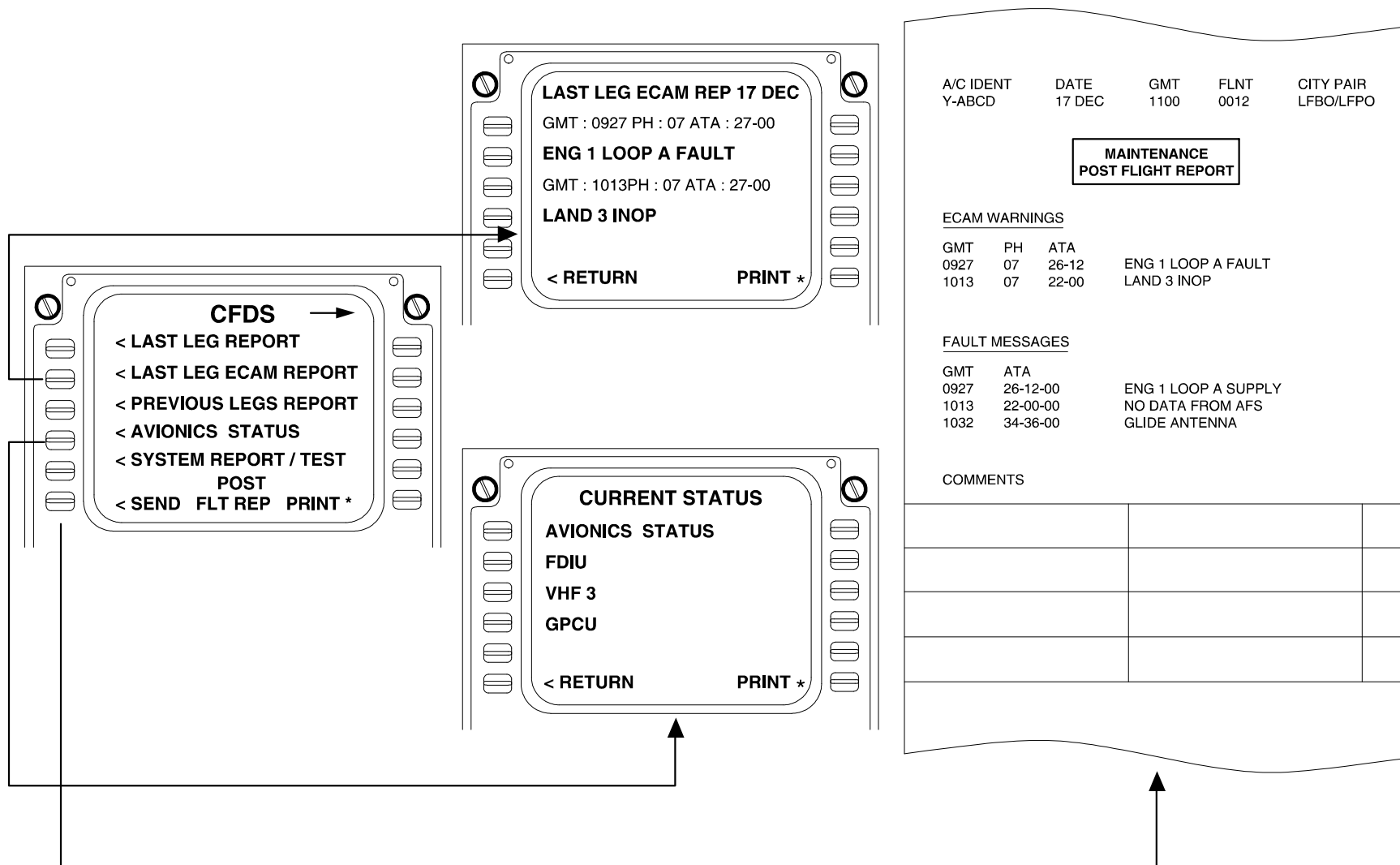



# A319/A320/A321 CFDS – example of use - 3

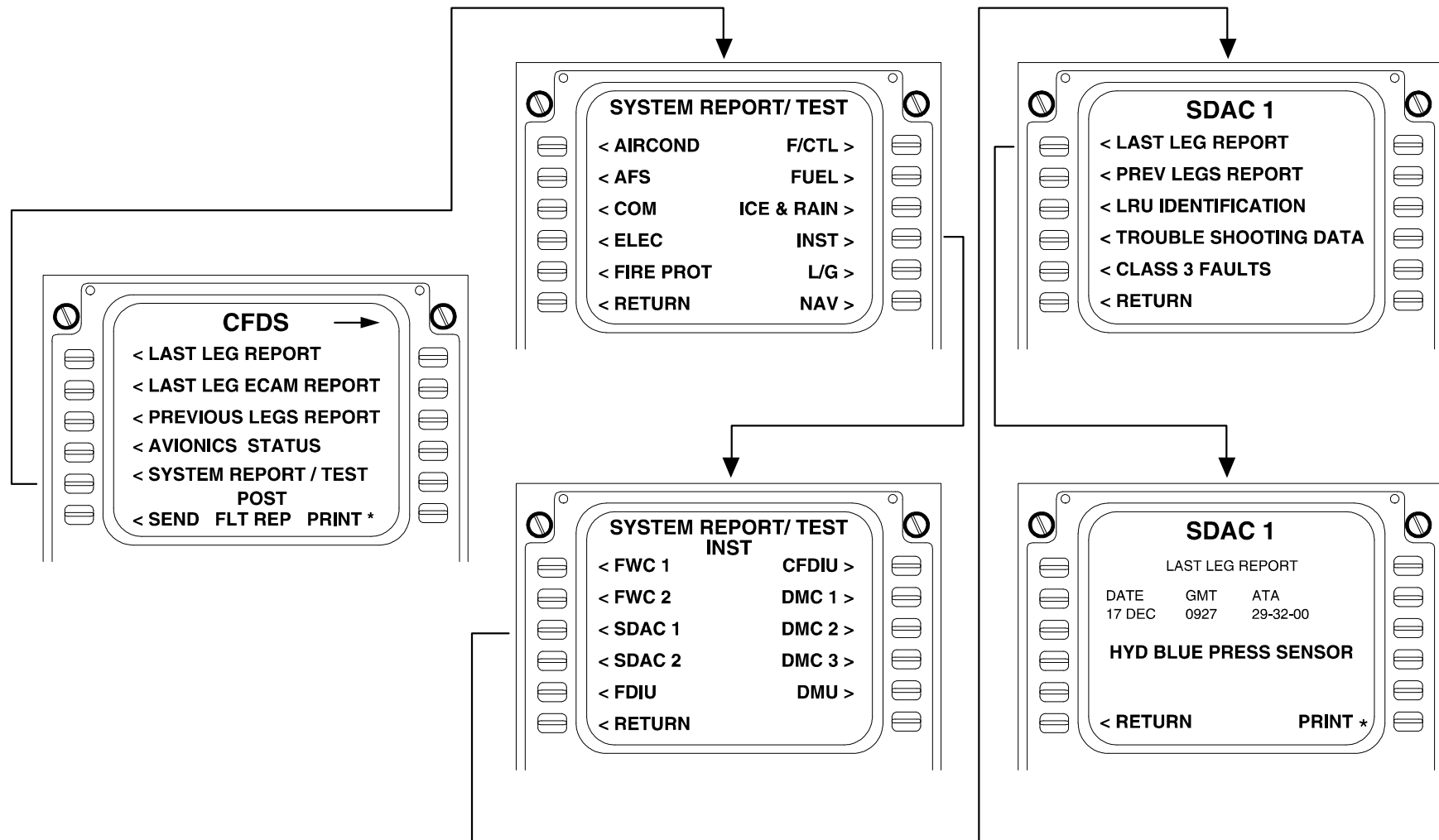



**AIRBUS**

*31707 Blagnac Cedex  
France  
Telephone 05 61 93 33 33*

**©Airbus Industrie 1999  
All right reserved.**

The statements made herein do not constitute an offer. They are based on the assumptions shown and are expressed in good faith. Where the supporting grounds for these statements are not shown, the Company will be pleased to explain the basis thereof.

This document is the property of Airbus Industrie and is supplied on the express condition that it is to be treated as confidential. No use or reproduction may be made thereof other than that expressly authorised.