

Data sheet

# Temperature controller AVT with safety temperature monitor STM / VGS for steam (PN 25)

Description



The controllers are:

- Type-tested acc. to EN 14597 and protect against exceeding temperatures:
- Applications:
  - District heating systems acc. to DIN 4747
  - Heating systems acc. to EN 12828 (DIN 4751) and EN 12953-6 (DIN 4752)
  - Water heating systems for drinking and industrial waters acc. to DIN 4753

**Main data:**

- DN 15-25
- $k_{vs}$  1.0-6.3 m<sup>3</sup>/h
- PN 25
- Setting ranges:
  - STM monitor: 20 ... 75 °C / 40 ... 95 °C / 30 ... 110 °C
  - AVT thermostatic actuator: -10 ... 40 °C / 20 ... 70 °C / 40 ... 90 °C / 60 ... 110 °C and 10 ... 45 °C / 35 ... 70 °C / 60 ... 100 °C / 85 ... 125 °C
- Temperature:
  - Steam / circulation water / glycolic water up to 30 %: 2 ... 200 °C
- Connections:
  - Ext. thread (weld-on, thread and flange tailpieces)
- Flow and return mounting

STM/VGS and STM/AVT/VGS are self-acting proportional temperature controllers used for temperature control and temperature monitoring primarily in steam or hot water applications for temperatures up to 200 °C.

VGS - valve with external thread  
Controller closes on rising temperature.

Ordering

Example 1 - **STM/VGS** controller: Safety temperature monitor for steam; DN 15;  $k_{vs}$  1.6; PN 25; limit range 30 ... 110 °C;  $T_{max}$  200 °C; ext. thread

- 1x VGS DN 15 valve  
Code No: **065B0787**
- 1x STM monitor, 30 ... 110 °C  
Code No: **065-0608**

Option:

- 1x Weld-on tailpieces  
Code No: **003H6908**

All products will be delivered separately. The valve VGS will be delivered (assembled) together with an adapter M34 x M45.

VGS valve <sup>1)</sup>

Picture	DN (mm)	$k_{vs}$ (m <sup>3</sup> /h)	Connection	Code No.
	15	1.0	Cylindrical external thread acc. to ISO 228/1	<b>065B0786</b>
		1.6		G ¾ A <b>065B0787</b>
		3.2		<b>065B0788</b>
	20	4.5		G 1 A <b>065B0789</b>
	25	6.3		G 1¼ A <b>065B0790</b>

<sup>1)</sup> Adapter M34 x M45 for connection to STM thermostat is factory assembled on the valve.  
(info: Adapter M34 x M30 for connection to AMV(E) electrical actuators is part of the valve delivery too.)

STM Safety temperature monitor (actuator)

Picture	For valves	Limit range (°C)	Temperature sensor with brass immersion pocket, length, connection	Code No.
	DN 15-50	30 ... 110	210 mm, R ¾ <sup>1)</sup>	<b>065-0608</b>
		20 ... 75		<b>065-0609</b>
		40 ... 95		<b>065-0610</b>

<sup>1)</sup> conic male thread EN 10226-1

**Ordering (continuous)**

Example 2 - STM/AVT/VGS controller:

Temperature controller with safety temperature monitor for steam; DN 15;  $k_{vs}$  1.6; PN 25; limit range 30 ... 110 °C; setting range 40 ... 90 °C;  $T_{max}$  200 °C; ext. thread

- 1x VGS DN 15 valve  
Code No: **065B0787**
- 1x STM monitor, 30 ... 110 °C  
Code No: **065-0608**
- 1x AVT thermostatic actuator, 40 ... 90 °C  
Code No: **065-0598**
- 1x K2 combination piece  
Code No: **003H6855**

Option:

- 1x Weld-on tailpieces  
Code No: **003H6908**

All products will be delivered separately. The valve VGS will be delivered (assembled) together with an adapter M34 x M45.

**AVT thermostatic actuator**

Picture	For valves	Setting range (°C)	Temperature sensor with brass immersion pocket, length, connection	Code No.
	DN 15-25	-10 ... +40	210 mm, R 3/4 <sup>1)</sup>	<b>065-0600</b>
		20 ... 70		<b>065-0601</b>
		40 ... 90		<b>065-0602</b>
		60 ... 110		<b>065-0603</b>
		10 ... 45	255 mm, R 3/4 <sup>1)2)</sup>	<b>065-0604</b>
		35 ... 70		<b>065-0605</b>
		60 ... 100		<b>065-0606</b>
		85 ... 125		<b>065-0607</b>

<sup>1)</sup> conic male thread EN 10226-1  
<sup>2)</sup> without immersion pocket

**Accessories for valves**

Picture	Type designation	DN	Connection	Code No.
	Weld-on tailpieces	15	-	<b>003H6908</b>
		20		<b>003H6909</b>
		25		<b>003H6910</b>
	External thread tailpieces	15	Conical ext. thread acc. to EN 10226-1	R 1/2 <b>003H6902</b>
		20		R 3/4 <b>003H6903</b>
		25		R 1 <b>003H6904</b>
	Flange tailpieces	15	Flanges PN 25, acc. to EN 1092-2	<b>003H6915</b>
		20		<b>003H6916</b>
		25		<b>003H6917</b>

**Accessories for thermostats**

Picture	Type designation	For controllers	Material	Code No.
	Immersion pocket PN 25	AVT/VGS	Brass	<b>065-4416</b> <sup>1)</sup>
		STM/VGS	Stainless steel, mat. No. 1.4435	<b>065-4417</b> <sup>1)</sup>
	Adapter <sup>2)</sup>		M34 x 1.5 mm/M45 x 1.5 mm	<b>003H6927</b>
	Combination piece K2			<b>003H6855</b>
	Combination piece K3			<b>003H6856</b>

<sup>1)</sup> Not for AVT thermostatic actuator code numbers: **065-0604, 065-0605, 065-0606, 065-0607**  
<sup>2)</sup> Adapter for VGS combinations with thermostatic actuator AVT, temperature monitors STM and temperature limiters STL

**Service kits**

Picture	Type designation	for valves DN	$k_{vs}$	Code No.
	Valve body extension with stuffing box	15	3.2	<b>003H6877</b>
		20	4.5	
		25	6.3	
	Housing of sensor stuffing box	<b>for sensors</b>		<b>Code No.</b>
		AVT R 3/4		<b>065-4421</b>

Technical data

VGS valve

Nominal diameter		DN	15			20	25
$k_{vs}$ value		m <sup>3</sup> /h	1.0	1.6	3.2	4.5	6.3
Stroke		mm	3			5	
Control ratio							> 1:50
Control characteristic							linear
Cavitation factor z							≥ 0.6
Leakage acc. to standard IEC 534	% of $k_{vs}$						≤ 0.05
Nominal pressure	PN						25
Max. differential pressure	bar						10
Media							Steam/Circulation water/glycolic water up to 30 %
Media pH							Min. 7, max. 10
Media temperature	°C						2 ... 200
Connections	valve						External thread
	tailpieces						Weld-on, external thread and flange
<b>Materials</b>							
Valve body							Red bronze CuSn5ZnPb (Rg5)
Valve seat							Stainless steel, mat. No. 1.4571
Valve cone							Stainless steel, mat. No. 1.4122
Pressure relieve system							Bellows

STM Safety temperature monitor (actuator)

Limit range $X_s$	°C	30 ... 110 / 20 ... 75 / 40 ... 95
Time constant T acc. to EN 14597	s	max. 100
Gain $K_s$	mm/°K	0.3
Max. adm. temperature at sensor	80 °C above maximum setpoint	
Max. amb. temperature at thermostat	°C	0 ... 70
Nominal pressure sensor	PN	25
Nominal pressure immersion pocket		
Capillary tube length	m	5
<b>Materials</b>		
Temperature sensor	Cooper	
Immersion pocket	Ms design	Brass, nickel-plated
	Stainless steel design	mat. No. 1.4435
Handle for temp. setting	Polyamide, glass fiber-reinforced	
Scale carrier	Polyamide	

AVT Thermostatic actuator

Setting range $X_s$	°C	-10 ... 40 / 20 ... 70 / 40 ... 90 / 60 ... 110 10 ... 45 / 35 ... 70 / 60 ... 100 / 85 ... 125
Time constant T acc. to EN 14597	s	max. 50 (210 mm), max. 30 (255 mm)
Gain $K_s$	mm/°K	0.3 (210 mm); 0.7 (255 mm)
Max. adm. temperature at sensor	50 °C above maximum setpoint	
Max. amb. temperature at thermostat	°C	0 ... 70
Nominal pressure sensor	PN	25
Nominal pressure immersion pocket		
Capillary tube length	5 m (210 mm), 4 m (255 mm)	
<b>Materials</b>		
Temperature sensor	Cooper	
Immersion pocket <sup>1)</sup>	Ms design	Brass, nickel-plated
	Stainless steel design	Mat. No. 1.4435 (210 mm)
Handle for temp. setting	Polyamide, glass fiber-reinforced	
Scale carrier	Polyamide	

<sup>1)</sup> for sensor 210 mm

Application principles

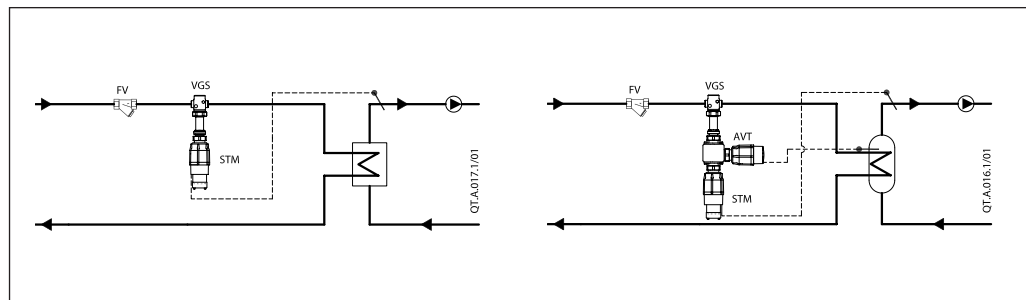

Combinations

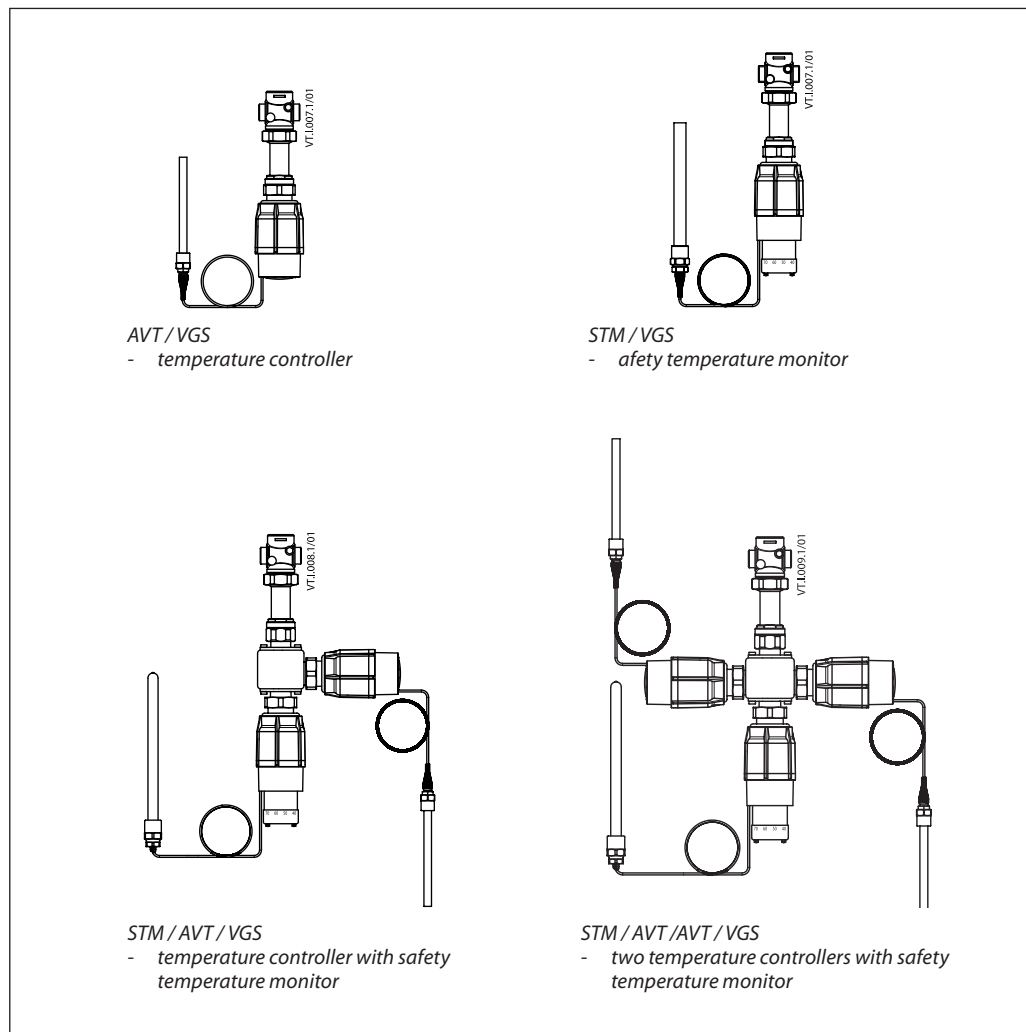

**Installation positions**

*Temperature controller and safety temperature monitor*

Up to media temperature of 160 °C temperature controller AVT/VGS and safety temperature monitor STM/VGS can be installed in any position.

For higher temperatures temperature controller AVT/VGS and safety temperature monitor STM/VGS have to be installed horizontal and in horizontal pipes with the actuator oriented downwards.

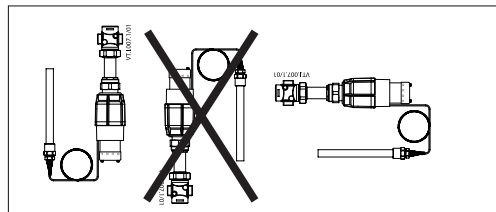
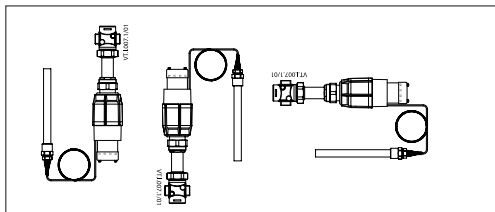

*Temperature sensor*

The place of installation must be chosen in a way that the temperature of the media is directly taken without any delay. Avoid overheating of temperature sensor. The temperature sensor must be immersed into the media in its full length.

*Temperature sensors 170 mm R1/2 and 210 mm R3/4*

- The temperature sensor may be installed in any position.

*Temperature sensor 255 mm R3/4*

- The temperature sensor must be installed as shown on the picture.

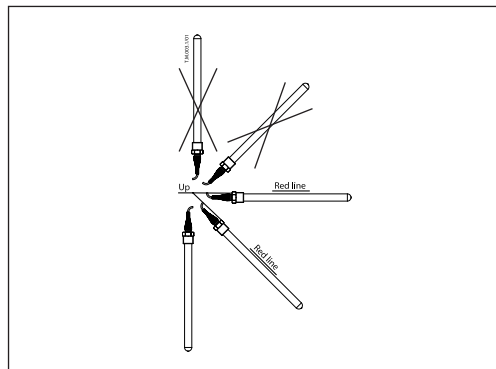
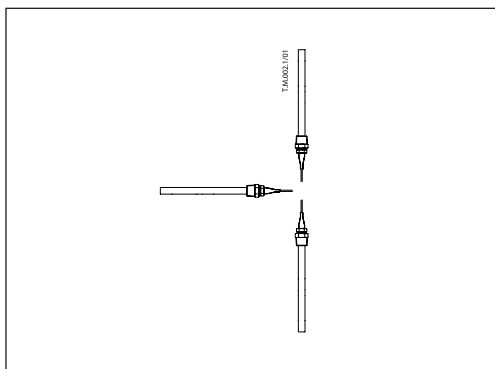

**Pressure temperature diagram**

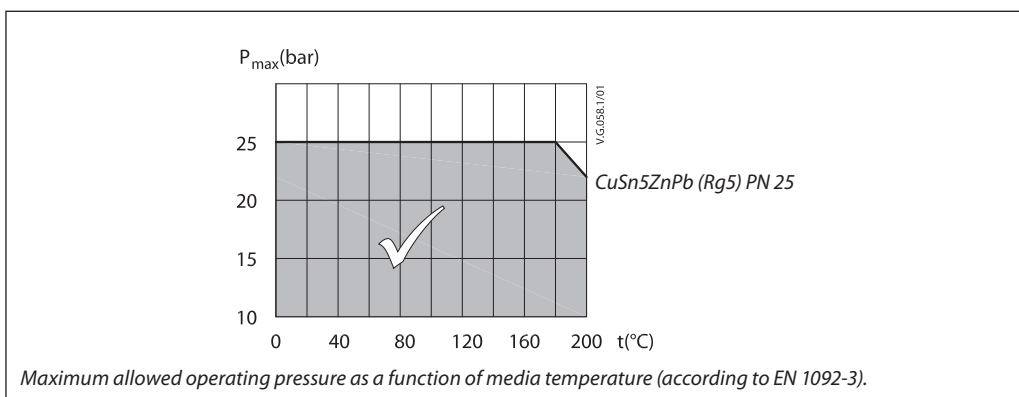

Valve sizing

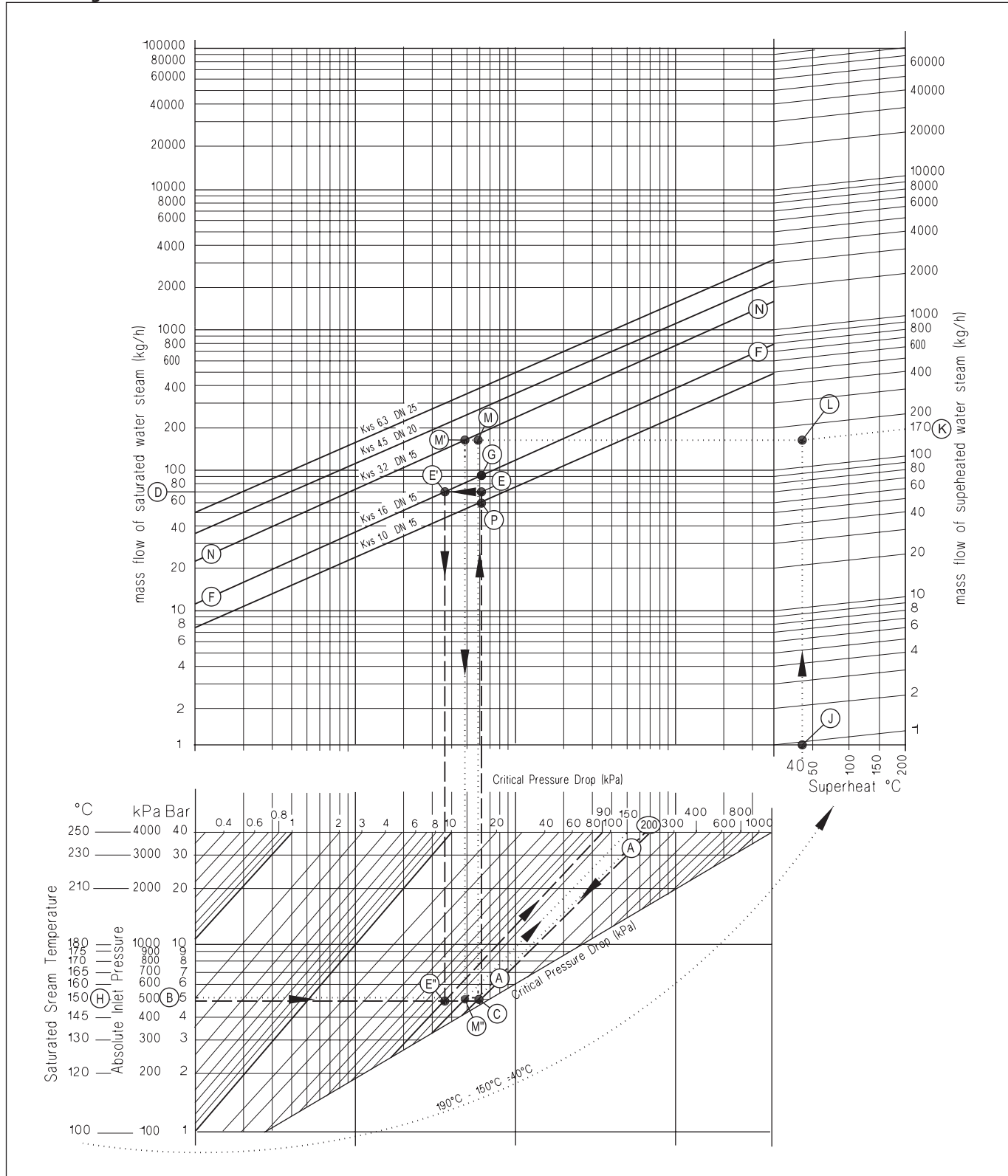

Steam valve sizing is based on 40 % drop of the steam pressure across the valve when fully open. At this condition the steam is travelling at or close to its critical velocity (approx. 300 m/s) and throttling would occur over the full valve stroke.

If the steam is travelling slower than this, then the first part of the valve stroke would merely increase the velocity of the steam without reducing the volumetric flow.

**Valve sizing** (continuous)

**1. For saturated steam**

*Given data:*  
 Flow rate: 70 kg/h  
 Absolute inlet pressure: 5 bar (500 kPa)

**Remark:**  
 For this example follow dashed line

The absolute inlet pressure is 500 kPa. Critical pressure drop (40 % of 500 kPa) is 200 kPa. Locate the diagonal line corresponding to the pressure drop of 200 kPa (line A-A).

Read the absolute inlet pressure on the lower left hand scale (point B), and draw a horizontal line across until it meets the pressure drop diagonal A-A at point C.

From this point C extend a vertical line upwards until it meets the horizontal line representing the steam flow of 70 kg/h from point D. The intersection of this is point E.

The nearest diagonal  $k_{vs}$  line above this is line F-F with a  $k_{vs}$  of 1.6. If the ideal valve size is not available the next largest size should be selected to ensure design flow.

The pressure drop through valve at the flow rate is found by the intersection of the 70 kg/h line with F-F (point E') and dropping a vertical line downwards; this actually hits the horizontal line for 500 kPa absolute inlet pressure (point E'') at a pressure drop diagonal of 90 kPa. This is only 18 % of the pressure drop across the valve and the control quality will not be good until the valve has partially closed. As with all steam valves this compromise is necessary since the next smaller valve would not pass the required flow (maximum flow would be about 60 kg/h; point P).

The maximum flow for the same inlet pressure is found by extending the vertical line (C-E) through point E until it crosses the  $k_{vs}$  1.6 line F-F (point G) and reading off the flow (90 kg/h).

**2. For superheated steam**

*Given data:*  
 Flow rate: 170 kg/h  
 Absolute inlet pressure: 5 bar (500 kPa)  
 Steam temperature: 190 °C

**Remark:**  
 For this example follow dotted line  
 The procedure for superheated steam is much the same as for saturated steam, but uses a different flow scale which slightly elevates the readings according to the degree of superheat.

As before, the diagonal critical pressure drop line A-A is located at 40 % of 500 kPa (200 kPa). The horizontal inlet pressure line through point B is now extended to the left to read off the corresponding saturated steam temperature at point H (150 °C). The difference between the saturated steam temperature and the superheated steam temperature is 190 °C – 150 °C = 40 °C (see point J).

The superheated steam flow 170 kg/h is found on the upper right hand scale (point K). From here the diagonal line is followed down until it meets a vertical line from the steam temperature elevation (40 °C, point J) at point L.

As before, the horizontal line through point B is drawn to cut line A-A at point C. The point where the vertical line from point C meets the horizontal line from point L is the operating point (point M). This horizontal line, L-M, is the corrected flow line. The nearest diagonal line above this is line N-N with a  $k_{vs}$  3.2. A vertical line dropped from the intersection of L-M line with line N-N (point M') intersects the 500 kPa absolute inlet pressure line (point M'') at a pressure drop diagonal of about 150 kPa. This is about 30 % of the pressure drop across the valve which will give reasonable control quality (compared to recommended ratio of 40 %).

**Design**

**STM/VGS**

1. Valve VGS
2. Valve insert
3. Pressure relieved valve cone
4. Valve stem
5. Valve body extension
6. Union nut
7. Safety temperature monitor STM
8. Thermostat stem
9. Setting spring for temperature control
10. Handle for limit setting, prepared for sealing
11. Scale carrier
12. Capillary tube
13. Temperature sensor
14. Immersion pocket
15. Safety spring

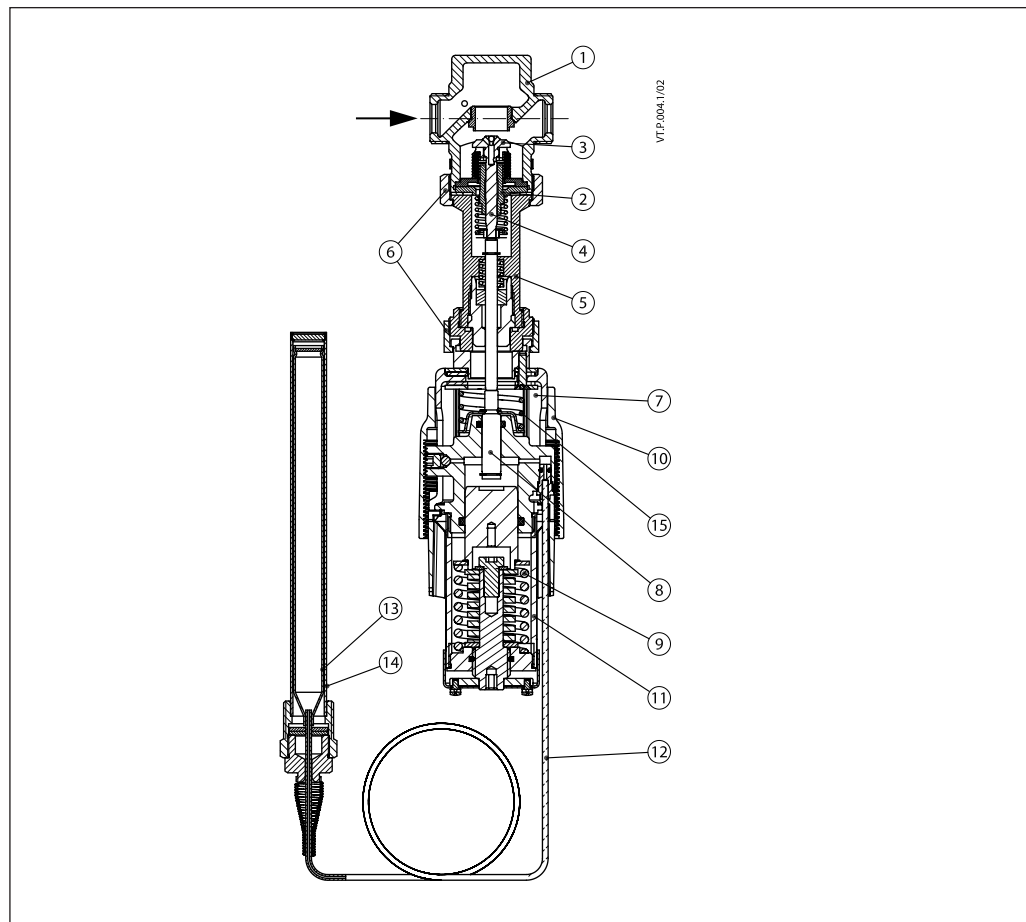

**AVT/VGS**

1. Valve VGS
2. Valve insert
3. Pressure relieved valve cone
4. Valve stem
5. Valve body extension
6. Union nut
7. Thermostatic actuator AVT
8. Thermostat stem
9. Bellows
10. Setting spring for temperature control
11. Handle for temperature setting, prepared for sealing
12. Scale carrier
13. Capillary tube
14. Flexible protected pipe (only at AVT 255 mm)
15. Temperature sensor
16. Immersion pocket
17. Sensor stuffing box
18. Housing of sensor stuffing box

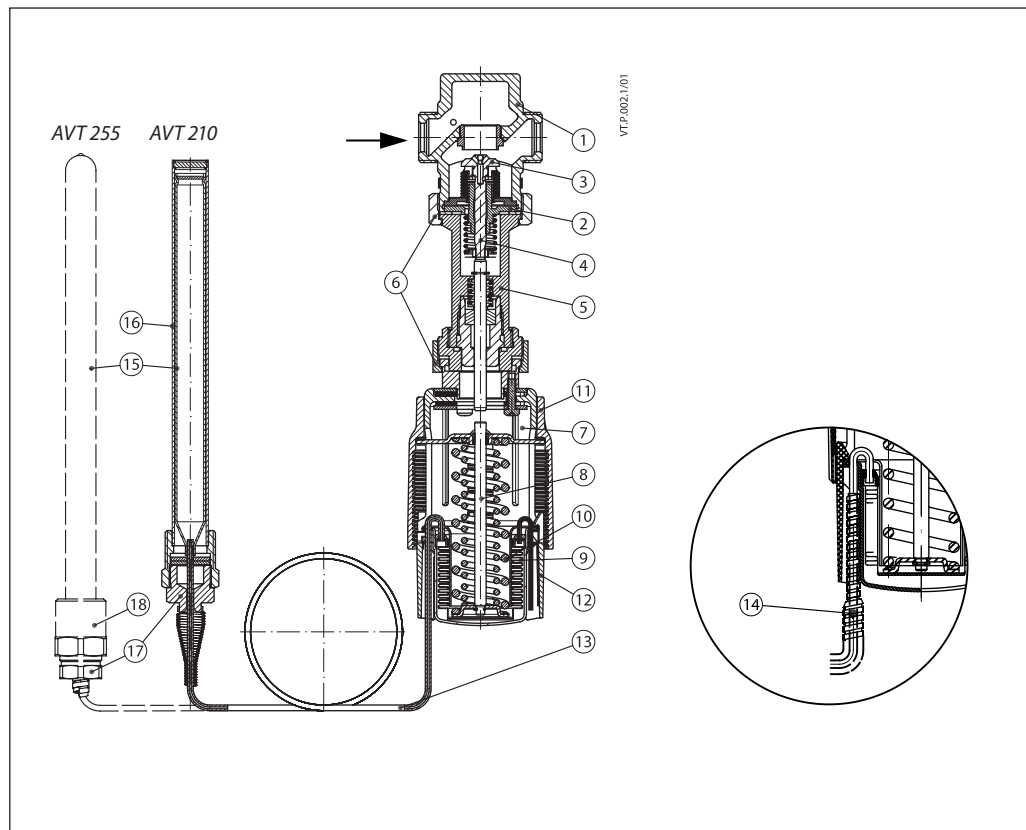



**Function**

*Mode of Operation*

The safety temperature monitor is proportional temperature controller which controls the temperature and protects the system against exceeding temperatures. The valve cone is soft sealed and pressure relieved.

The safety temperature monitor operates in accordance with the liquid expansion principle. The temperature sensor, the capillary tube and the bellows are filled with liquid. As the temperature at the temperature sensor rises, the liquid expands, the thermostat stem moves out and closes the valve.

*Safety Temperature Monitor (STM/VGS)*

- Function  
In case the temperature at the temperature sensor exceeds the adjusted set point, safety temperature monitor interrupts energy supply by closing the valve. As soon as the temperature at the temperature sensor drops, the valve opens automatically.

*Temperature Controller (AVT/VGS)*

- Function  
By increasing of media temperature valve cone moves towards the seat (valve closes), by decreasing of media temperature valve cone moves away from the seat (valve opens).

Handle for limit setting can be sealed

Handle for temperature setting can be sealed.

- Extended safety function  
If there is a leakage in the area of the temperature sensor, the capillary tube, or the thermostat, the valve closes by a spring in the safety thermostat. In this case safety temperature monitor (actuator) must be replaced.
- Physical Function Principle

- Physical Function Principle  
Media temperature changes cause pressure changes in temperature sensor. Resulting pressure is being transferred through the capillary tube to the bellows. Bellows moves thermostat stem and opens or closes the valve.

**Settings**

*Temperature setting (AVT/VGS)*

Temperature setting is being done by the adjustment of the setting spring for temperature control. The adjustment can be done by means of handle for temperature setting and/or temperature indicators.

*Limit setting (STM/VGS)*

Limit setting is being done by the adjustment of the setting spring for temperature control. The adjustment can be done by means of handle for limit setting and/or temperature indicators.

**Adjustment diagram**

*Temperature setting*

Relation between scale numbers 1-5 and closing temperature.

**Note:** The values given are approximate

AVT Thermostat ... 210 mm					
I	II	III	III	IIII	
-10	3	15	28	40	°C
20	33	45	58	70	
40	53	65	78	90	
60	73	85	98	110	

  

AVT Thermostat ... 255 mm					
I	II	III	III	IIII	
10	19	28	36	45	°C
35	44	53	61	70	
60	70	80	90	100	
85	95	105	115	125	

**Note:**

STM Safety temperature monitor (actuator):  
temperature scale is already written on the product

Dimensions

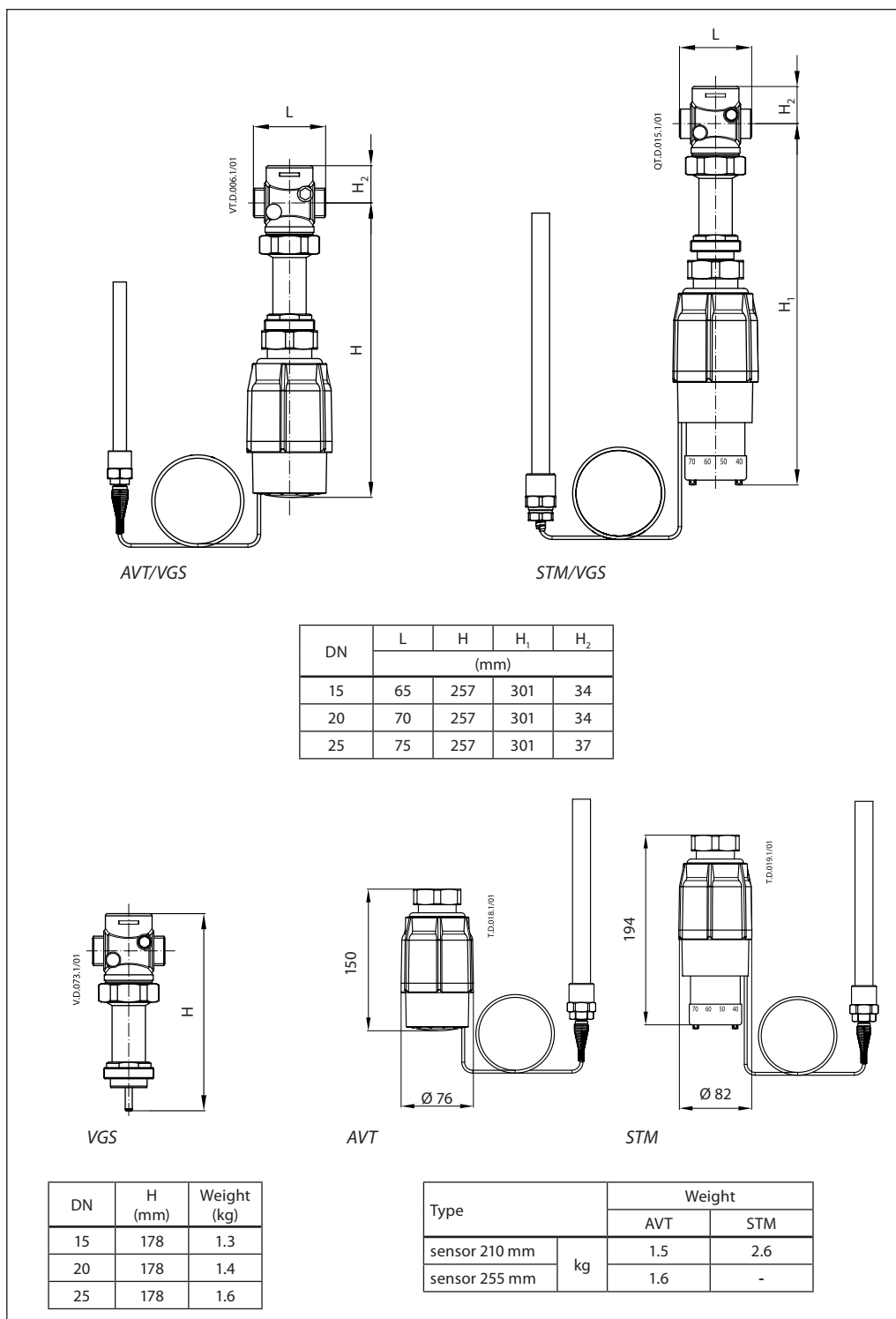

Dimensions (continuous)

