



156 Epping Road Exeter, NH 03833 800-261-7219

---

Stock Number: 434138

2022 Black Kenworth T270

---

**Details:**

- 2021 NRC 20TB-22' Fully Galvanized Deck & Subframe
- 10K Winch
- Lodar Remote
- 300 HP
- Allison 2500 6-speed
- Paccar PX-7
- 26,000 GVW
- Full Chassis / Body spec attached

**Price: \$122,712**

We are the industry leader in design, sales and service for custom wreckers.



**NEW ENGLAND TRUCK CENTER  
 156 EPPING RD  
 EXETER, New Hampshire 03833  
 United States of America**

**Mike**

## Vehicle Summary

	<b>Unit</b>		<b>Chassis</b>
Model:	T270 Series Conventional	Fr Axle Load (lbs):	10000
Type:	FULL TRUCK	Rr Axle Load (lbs):	20000
Description 1:	T2704X2MY 22	G.C.W. (lbs):	26000
Description 2:			
	<b>Application</b>	Road Conditions:	
Intended Serv.:	Local pickup & delivery: Vehicles which	Class A (Highway)	90
Commodity:	Auto transporter.	Class B (Hwy/Mtn)	10
		Class C (Off-Hwy)	0
	<b>Body</b>	Class D (Off-Road)	0
Type:	Roll back flatbed.	Maximum Grade:	6
Length (ft):	22	Wheelbase (in):	230
Height (ft):	13	Overhang (in):	75
Max Laden Weight (lbs):	4000	Fr Axle to BOC (in):	68
		Cab to Axle (in):	162
	<b>Trailer</b>	Cab to EOF (in):	237
No. of Trailer Axles:	0	Overall Comb. Length (in):	345.9
Type:			
Length (ft):	0	<b>Special Req.</b>	
Height (ft):	0	U.S. Domestic registry, 50-state.	
Kingpin Inset (in):	0		
Corner Radius (in):	0		
	<b>Restrictions</b>		
Length (ft):	75		
Width (in):	102		
Height (ft):	13.5		

**Approved by:** \_\_\_\_\_

**Date:** \_\_\_\_\_

**Note: All sales are F.O.B. designated plant of manufacture.**

<i>Std/ Opt</i>	<i>Description</i>	<i>Weight</i>
<b>Model</b>		
O	<b>T270 Series Conventional</b> Electric Door locks LH/RH; Ignition & doors keyed alike; Single electric horn; Single-piece windshield; Electric windshield wipers, 2-speed plus intermittent; Electric windshield washers; Steering wheel 18in. 4-spoke; Glovebox door with locking latch; Dash-mounted cruise control with switches; Turn signal switch with column-mounted dimmer; Standard gray dash panels; Slate Gray interior primary color; Dark Slate Gray seat color; Floormat; Inside sunvisor, LH/RH; Door courtesy lights; Under-dash center console with 1 cup holder, 1 ashtray & 1 lighter.	<b>9,264</b>
S	<b>T270 Class 6: medium-duty Conventional.</b>	<b>0</b>
O	<b>Chassis operation will not include</b> a stationary application. Stationary operation is defined as running the engine under load while stationary at a substantial fraction of engine gross horsepower (60% or greater) for an extended period of time (longer than 5 - 10 minutes).	<b>0</b>
O	<b>CARB Idle Emissions Reduction Feature for PX-7 and PX-9</b>	<b>0</b>
O	<b>Class 6 4x2 automatic.</b>	<b>0</b>
<b>Engine &amp; Equipment</b>		
O	<b>PACCAR PX-7 300 2017 300@2600 660@1600</b> Includes turbo exhaust brake, no code is used. Diagnostic Plug for data link, Oil Cooler, Aluminum Flywheel Housing. N09260 P14 75....Max Vehicle Speed in Top Gea N09440 P11 YES...Engine Protection Shtdwn N09460 P06 NO....Gear Down Protection N09300 P19 75....Max Cruise Control Speed N09720 P230 YES...Enable Hot Ambient Automatic N09500 P02 YES...Cruise Control Auto Resume N09520 P04 YES...Auto Engine Brake in Cruise N09480 P26 1400..Max PTO Speed N09580 P32 1.....Idle Shtdwn Time N09680 P33 NO....Idle Shtdwn Override N09560 P520 NO....Enable Idle Shutdown Park Br N09600 P233 YES...Enable Impending Shutdown Wa N09780 P47 80....High Ambient Temperature Thr N09740 P46 0.....Low Ambient Temperature Thre N09200 N205 120...Standard Maximum Speed Limit N09620 P234 30....Timer For Impending Shutdown N09360 N203 252...Reserve Speed Function Reset N09640 P516 0.....Engine Load Threshold N09400 N206 10....Maximum Active Distance (N20 N09420 N201 0.....Reserve Speed Limit Offset ( N09760 P56 60....Intermediate Ambient Tempera N09380 N202 0.....Maximum Cycle Distance (N202 N09220 N207 0.....Expiration Distance (N207) N09540 N209 0.....Expiration Distance (N209)	<b>0</b>

<b>Std/ Opt</b>	<b>Description</b>	<b>Weight</b>
S	<b>PremierSpec</b>	0
S	<b>Gearing Analysis: Performance</b> power before economy results.	0
S	<b>Customer's Typical Operating Spd: 65 mph.</b>	0
O	<b>Effective VSL Setting NA</b>	0
O	<b>Engine Idle Shutdown Timer Disabled</b>	0
O	<b>Enable EIST Ambient Temp Overrule</b>	0
O	<b>Eff EIST NA Expiration Miles</b> Use only with MX and Cummins engines	0
S	<b>Air compressor: Cummins 18.7 CFM For Cummins And</b> PACCAR PX engines.	0
O	<b>Air Cleaner: Dry-type firewall mounted w/filter</b> restriction indicator.	0
O	<b>Filter minder air restriction indicator mounted</b> on air cleaner replacing standard pop-up indicator.	0
O	<b>Fan Hub: Horton 2-Speed for PX-7</b>	0
S	<b>Cooling module: 1000 square inches</b> T170/T270/T370/T470. Includes metal surge tank on T170/T270/T370.	0
O	<b>Bug screen: Front of grille on C500 ,T800, T880,</b> and W900. Behind grille on T680 and T300 (Medium Duty).	2
S	<b>Exhaust: 2017 EPA Horizontal Under Rail</b> DPF/SCR for PX-7 w/ Horizontal Tailpipe Below RH Rail, BOC.	0
S	<b>Fuel Filter:PACCAR Standard Service Interval</b> Fuel/Water Separator. 2017 and Later Emissions	0
O	<b>Run Aid:None</b> *For Fuel Filter	0
O	<b>Start Aid:12V Heat</b> *For Fuel Filter	1
O	<b>Engine block heater plug mounted LH fender</b> bracket.	0
O	<b>Block heater, PACCAR 750 watt 120V for PX-6</b> and PX-7, 1000 watt for PX-8 and PX-9 or ISL9 engines .	2
O	<b>Alternator: PACCAR 160 amp, brush type</b>	0
S	<b>Batteries: 2 PACCAR GP31 threaded post (700-730)</b> 1400-1460 CCA dual purpose.	0
S	<b>Starter: PACCAR 90P47 12V with PACCAR PX-7</b>	0
O	<b>Multi-function engine connector for body builder</b> interface for Cummins.	0
O	<b>Jump start terminals under hood.</b>	0

## Transmission & Clutch

<i>Std/ Opt</i>	<i>Description</i>	<i>Weight</i>
O	<b>Transmission: Allison 2500RDS 6-speed</b> w/PTO drive gear. 5th Gen controls. Includes heat exchanger. Rugged Duty Series for vocational applications. Transynd transmission fluid is standard on all Allison 1000, 2000, 3000 & 4000 series transmissions.	0
O	<b>Driveline: 3 Dana SPL100a 2 centerbearings</b> light duty	58
O	<b>Torque converter included w/Allison</b> Transmission.	0
O	<b>Delete Allison Fuel Sense</b>	0
O	<b>J1939 Park Brake Auto Neutral</b>	0
O	<b>Decline Allison Neutral at Stop Stand-Alone</b>	0
<b>Front Axle &amp; Equipment</b>		
S	<b>Dana Spicer E-1002IL Front Axle rated 10K</b> 3-1/2in. drop. Use w/ air brakes only.	0
S	<b>Front brakes included w/ front hub package.</b>	0
O	<b>Air Brake: 14,600 lb. package includes</b> Bendix 16-1/2 x5 brakes, cast drums, aluminum 10-bolt hub pilot Preset hubs, hubcaps, oil seals & automatic slack adjusters. For use w/ 22-1/2in. wheels.	48
S	<b>Front Springs: Taperleaf 10K w/ shock absorbers</b> for use on 2010+ chassis w/ 22.5in. wheels only.	0
S	<b>Single power steering gear: 13.2K for air brakes.</b>	0
<b>Rear Axle &amp; Equipment</b>		
O	<b>Single Dana Spicer P22060S single reduction rear</b> axle. T300/K300: use with/air brakes. Single rear axle 22K capacity rated at 20K.	117
O	<b>Rear Axle Ratio - 5.29.</b>	0
S	<b>Single rear brakes included w/rear hub package.</b>	0
O	<b>23K air brake package includes 16-1/2x7 in.</b> brakes, cast drums, aluminum 10-bolt hub pilot Preset hubs, automatic slack adjusters and oil seals for use w/ 22.5 in. wheels.	0
O	<b>Spring Brake: 3030 long stroke single 3 in.</b> travel. Helps keep brakes in adjustment longer.	4
O	<b>Dustshields for drum brakes: all rear axles.</b>	11
S	<b>Bendix 4S/4M anti-lock brake system.</b>	0
O	<b>Wheel Differential Lock for Dana Spicer Axle</b> P22060S; changes S to D to the axle part number.	15
O	<b>Rear suspension: single Kenworth Airglide 210L</b>	-145

<i>Std/ Opt</i>	<i>Description</i>	<i>Weight</i>
	21K. 6.5 in. ride height w/single leveling valve. Includes air suspension dump valve.	
O	<b>Bolted rear suspension crossmembers for AG210L.</b> Replaces T3 standard.	0
<b>Tires &amp; Wheels</b>		
O	<b>Front tires: Goodyear Endurance RSA 255/70R22.5</b> 16PR. 36.7in. Diameter, all positions, 17.3 SLR.	-42
O	<b>Rear tires:Goodyear Fuel Max RTD 255/70R22.5 16PR</b>	-80
O	<b>Rear Tire Quantity: 4</b>	0
O	<b>Front Wheel: Alcoa 88267 22.5x8.25 aluminum with</b> Lv One [TM] finish, hub-pilot mount. 7,400 lb. maximum rating. Air disc brake compatible.	-46
O	<b>Rear Wheel: Alcoa 88267 22.5x8.25 aluminum with</b> Level One [TM] finish, hub-pilot mount. 7400 lb. maximum rating. Air disc brake compatible. Code is priced per pair of wheels.	-88
O	<b>Wheelguards: all axles.</b>	2
O	<b>Single Front Axle: 2 wheels Dura-Bright Buffed.</b> Dura-Bright outboard surface of aluminum wheels.	0
O	<b>Single Rear Axle Wheels: 2 wheels Dura-Bright</b> Buffed. Dura-Bright outboard surface of outer dual or single aluminum wheels.	0
O	<b>Rear Wheel/Rim Quantity: 4</b>	0
<b>Frame &amp; Equipment</b>		
O	<b>Frame Rails: 10-5/8 x 3-1/2 x 5/16 in. Steel to</b> 309 in. to 380 in. Truck frame weight is 2.91 lb.-in. per pair of rails. Section modulus is 14.80 cu.in., RBM is 1,776,000 in-lbs per rail. 120,000 PSI yield. Heat treated. Frame rail availability may be restricted based upon application, axle/suspension capacity, fifth wheel setting, or component/dimensional specifications. The results of the engineering review may result in a change to the requested frame rail. If a change is required Kenworth Application Engineering will advise the dealer of the appropriate material specification for a substitute rail.	306
O	<b>Bumper: Aerodynamic Chrome Requires a bumper</b> setting code.	0
S	<b>40.9 in. Bumper setting. Requires a bumper code.</b>	0
O	<b>Removable Front Tow Hooks: 2.</b>	15
S	<b>Front mudflaps.</b>	0
O	<b>Battery box: Narrow steel parallel under cab</b> with aluminum diamond plate cover with step. LH under cab. Battery box is 150 mm narrower than the standard battery box. Use with two or three batteries and small round DEF tank LH under cab. Air tanks will	-25

<i>Std/ Opt</i>	<i>Description</i>	<i>Weight</i>
	be frame mounted. Air dryer must be frame mounted or under the hood. Use with RH under exhaust.	
S	<b>Battery box location: LH Side.</b>	0
S	<b>One-piece welded crossmember assembly with 12mm</b> frame fasteners, center and rear frame. Standard crossmember.	0
O	<b>Bolted Rear Cab Support Crossmember.</b> Replaces T3 standard.	17
O	<b>Class 6 26K GVWR, for air brakes only. Requires</b> GAWR front 10K, GAWR rear 20K; front axle 10K, front spring 10K, rear axle 20K. Maximum rear suspension is 23K.	0
O	<b>Final end-of-frame cut-off dimension will be</b> modified to less than or equal to 65 inches.	0
S	<b>Square end-of-frame w/o crossmember; non-towing.</b>	0

### Fuel Tanks & Equip

O	<b>Fuel Tank: 75 US gallon 22in. aluminum under</b> replace. Class 8 fuel tank includes an anti-siphon device on the filler neck.	-11
O	<b>Small round DEF tank. 11 gallons of</b> usable volume. The DEF tank will be located on the side you specified. If you have specific configuration or body builder concerns, please utilize the Custom Frame Layout option. Standard capacity is calculated by fuel capacity of the vehicle and will accommodate two diesel fill-ups for every DEF fill-up. For 1:1 DEF fuel fill ratio, add 7889204.	0
O	<b>Polish only one aluminum tank.</b>	0
O	<b>Polished cover for 1 DEF tank any size.</b>	3
O	<b>Polished stainless steel tank straps for 1 tank.</b>	0
S	<b>DEF to fuel fill ratio 2:1 or greater.</b>	0
S	<b>DEF tank location is LH.</b>	0
O	<b>Location: 75 gal fuel tank RH under cab</b>	0

### Cab & Equipment

S	<b>Cab: Curved Glass Conventional.</b> Cab Includes aluminum & fiberglass fully hucked cab w/ all aluminum bulkhead doors & continuous stainless steel piano-style door hinges. Single electric horn standard. Incandescent exterior lights include diagnosable bulb detection and warning. Trailer cable on tractors includes integrity detection. Standard features include multiplex wiring for interior lights, automated pre-trip inspection (excluding T3 series), short and open check diagnostics. Warning alarm will sound when lights are left on.	0
O	<b>Cab door bearing blocks, top &amp; bottom.</b>	0

<i>Std/ Opt</i>	<i>Description</i>	<i>Weight</i>
S	<b>Hood: Sloped aerodynamic hood includes</b> grill & separate bumper.	0
S	<b>Cab heater: W/integral defrosters &amp; A/C 45,000</b> btu cab heater. No sleeper heater/AC. Includes 5 mode rotary control. T660 include filter media.	0
S	<b>Adjustable telescoping tilt steering column.</b>	10
O	<b>5 sets of keys. Replaces standard 2 sets of keys.</b>	0
O	<b>Switch &amp; Wiring for Customer-Installed PTO.</b> Electric over hydraulic PTO. Includes switch guard. Wiring is routed to LH frame for connection to the customer installed PTO. No air controls are provided with this code.	0
O	<b>Information for customer-installed PTO</b> Chelsea 230 Series, 6-bolt	0
O	<b>Three spare switches: Wired to power.</b>	0
O	<b>Gauge: Air suspension pressure gauge.</b>	0
O	<b>Gauge: Fuel filter restriction gauge.</b>	0
O	<b>KW Driver Information Center: Includes fuel</b> economy, RPM display, trip information, truck information, diagnostics, gear display, alarm clock.	0
S	<b>Instrument package: Includes speedometer,</b> tachometer, fuel gauge, engine coolant temperature gauge, engine oil pressure, voltmeter. Class 8 also includes primary & secondary air reservoir gauges & an air application gauge. DEF level gauge and warning lamp are included with 2010+ engines. Engine hour meter and outside air temperature readouts are standard. Primary read out will be MPH. Add 8240620 to switch primary scale to KPH in Canada.	0
O	<b>Full burl wood dash panels</b>	0
S	<b>Cab interior: Pinnacle. Includes vinyl headliner</b> & cab back panel, slate gray interior, dark slate gray seats, floormats, LH/RH inside sunvisor & door courtesy lights.	0
O	<b>Driver seat: Kenworth Air cushion Plus HB vinyl.</b> Standard features includes 7 in. fore and aft slide adjustment w/isolator, 6-23 degree recline, air suspension with cover, dual armrests, and single chamber air lumbar support. Seat cushion is 20 inches wide w/ 2- position tilt and 2-position front cushion extension. Seat material has a horizontal stitch pattern and is 2-tone in color. Seat back is carpeted and includes a map pocket. Seat is manufactured by National. Includes inside visor and retractable 3-point matching seat belts. Grey seat belts.	2
O	<b>Rider seat: 2 man bench vinyl.</b> Standard features include 34.5 in. wide 2-tone seat cushion w/ fixed base. Armrests are not available. Seat back is carpeted. Includes inside visor and retractable 3-point matching seat belts. Grey seat belts.	61
O	<b>Seat color: All Jet Black.</b>	0



<b>Std/ Opt</b>	<b>Description</b>	<b>Weight</b>
O	<b>Kenworth Radio DEA710 AM/FM/WB/USB, Bluetooth</b>	0
S	<b>Under-dash center console: W/2 cup holders, 1 ashtray, 1 lighter, 1 12V outlet &amp; a storage compartment.</b>	0
O	<b>Dome lamp over driver door.</b>	0
S	<b>Self cancelling turn signal: W/head light dimmer switch .</b>	0
O	<b>Remote Keyless Entry</b>	0
O	<b>Grabhandle: LH inside door frame above dash.</b>	0
O	<b>Grabhandle: RH inside door frame above dash.</b>	2
S	<b>Daylite Door: LH/RH includes RH peeper window</b>	0
O	<b>Dual rectangular air horn 23 in. LH &amp; RH top of roof. Includes air horn covers.</b>	11
S	<b>Look-Down, Pass. Door, Stainless 8.5x4.4</b>	0
O	<b>Mirror: Dual Kenworth aerodynamic heated motorized 7 in. x 13 in. mirror w/ chrome shell. LH/RH convex mirrors 5 in. x 7 in. heated. Mirror brackets set for 8 1/2 ft load width. Switch located on door pad.</b>	26
S	<b>Rear Cab Stationary Window 17 in. x 36 in.</b>	0
O	<b>Electric-powered LH &amp; RH door window lifts. Switch located on door.</b>	0
O	<b>Exterior stainless steel sunvisor.</b>	11
<b>Lights &amp; Instruments</b>		
S	<b>Headlamps: Halogen Projector Low Beam, Halogen Complex Reflector High Beam</b>	0
O	<b>Marker Lights: Five, rectangular, LED</b>	0
S	<b>Turn Signal Lights: Mounted on fender</b>	0
O	<b>Turn Signal Flasher: Kysor solid state.</b>	0
O	<b>Switch &amp; Wiring for Customer-Installed Floodlight W/O Electrical Pass-Through - 1st Set. Wire Coiled BOC/BOS.</b>	0
S	<b>Combination Stop, Tail, Turn &amp; Backup Lights RH &amp; LH.</b>	0
O	<b>Electric Backup Alarm: Meets SAE J994 &amp; OSHA requirements.</b>	4
O	<b>Body Builder Lighting Harness Coiled End Of Frame For Additional Customer Installed Exterior Lighting. Harness Includes Circuits for Additional Customer Installed Tail Lamps, Turn Lamps, Stop Lamps, and Marker Lamps.</b>	0

<i>Std/ Opt</i>	<i>Description</i>	<i>Weight</i>
O	<b>Circuit Breakers: Replacing fuses. Does not</b> apply to any 5-amp fuse box position. Brakers include stop/brake/turn, tail lamp, high & low beams, marker/clearance lamps, horn, fuel heat, gauges, air dryer, HVAC controls, panel lamps. Some circuits will remain fuses.	0
<b>Air Equipment</b>		
O	<b>Air dryer: Bendix AD-SP heated.</b> With 2010 engine installations the dryer is mounted under the hood.	0
O	<b>Trailer ABS electric supply through SAE J560</b> 7-pin connector per TMC RP137).	0
<b>Extended Warranty</b>		
O	<b>Base Warranty - PACCAR PX-7 Engine</b> 36 months / Unlimited miles & km / Unlimited hours.	0
S	<b>Base Warranty - Standard Service Medium Duty</b> 12 months / Unlimited miles & km	0
<b>Miscellaneous</b>		
S	<b>GHG Secondary Manufacturer: Does Not Apply</b>	0
O	<b>Warning triangle reflector kit: Shipped loose.</b> Kit consists of 3 triangles in plastic carrying case. Not floor mounted.	4
O	<b>One 5 lb. dry chemical type fire extinguisher</b> mounted outboard of driver seat. Class ABC.	11
O	<b>Zinc Phosphate frame rail paint processing.</b> Requires frame rail code. Code is for 1 pair of rails.	0
<b>Promotions</b>		
U	<b>2020 2H TC551 PROGRAM TRACKING CODE</b>	0
<b>Paint</b>		
O	<b>Paint color number(s).</b>  N9702 A - L0006 WHITE N9720 FRAME N0001 BLACK	0
O	<b>Bumper Unpainted</b>	0
O	<b>Day Cab Standard Paint</b>	0
S	<b>1 - Color Paint - Day Cab</b> Color will be White if no other color is specified.	0
S	<b>Base coat/clear coat.</b> The Kenworth Color Selector contains additional instructions, as well as information on Kenworth paint guidelines and surface finish applications. Kenworth is standard with Dupont Imron Elite paint.	0

<i>Std/ Opt</i>	<i>Description</i>	<i>Weight</i>
---------------------	--------------------	---------------

**Order Comments**

Total Weight

9,570

## Prices and Specifications Subject to Change Without Notice.

---

Unpublished options may require review/approval.

Dimensional and performance data for unpublished options may vary from that displayed in CRM.

---

### **PRICING DISCLAIMER**

*While we make every effort to maintain the web site to preserve pricing accuracy, prices are subject to change without notice. Although the information in this price list is presented in good faith and believed to be correct at the time of printing, we make no representations or warranties as to the completeness or accuracy of this information. We reserve the right to change, delete or otherwise modify the pricing information which is represented herein without any prior notice. We carefully check pricing specifications, but occasionally errors can occur, therefore we reserve the right to change such prices without notice. We disclaim all liability for any errors or omissions in the materials. In no event will we be responsible for any damages of any nature whatsoever from the reliance upon information from these materials. Please check your order prebills to confirm your pricing information*

**Shipping Destinations**

**Intermediate Destination:**

<b>Final Destinations</b>	<b>Quantity</b>
---------------------------	-----------------

# HORIZONTAL DIMENSIONS

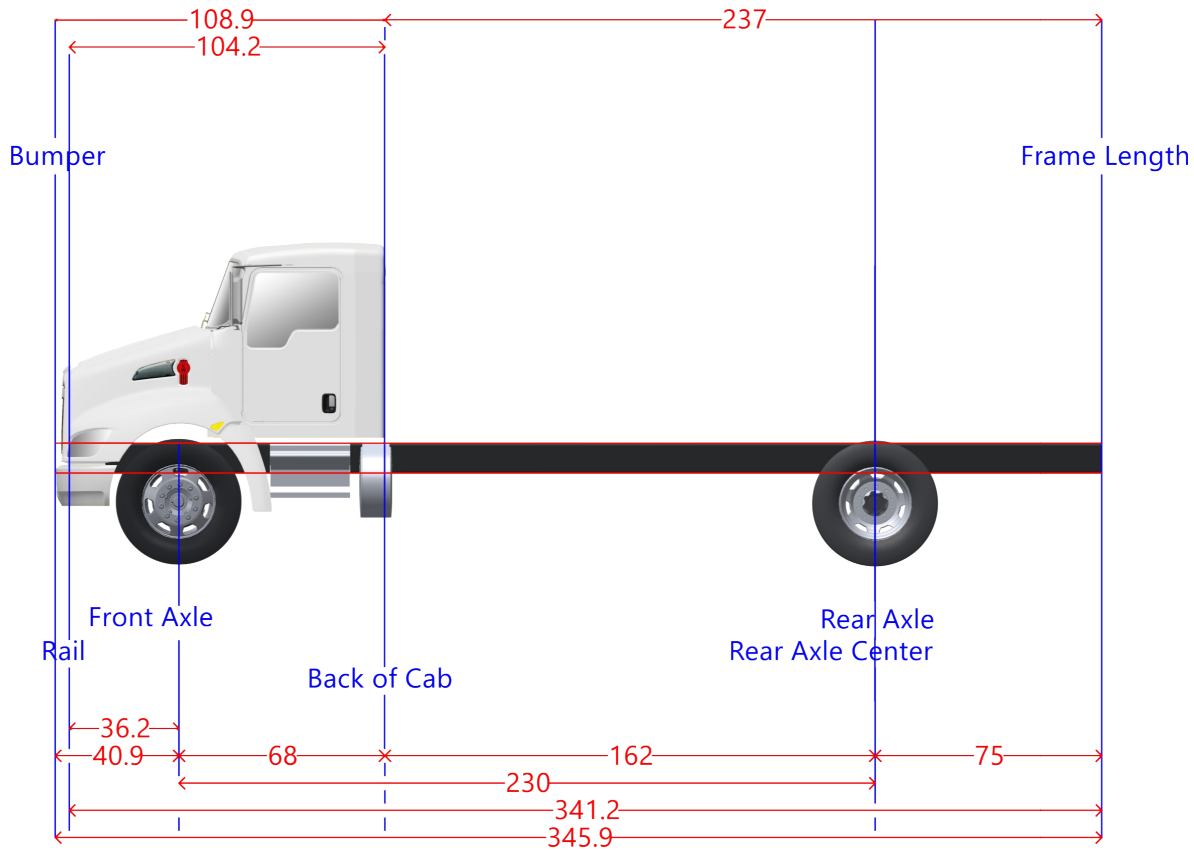

Dimension	Measurement	Start	End
Axle Spacing	0	230	230
Bumper to Back of Cab	108.9	-40.9	68
Bumper to Front Axle	40.9	-40.9	0
Bumper to Front Frame	4.7	-40.9	-36.2
Cab to End of Frame	237.0	68	305
Cab to Rear Axle	162.0	68	230
Effective Bumper to Back Of Cab	108.9	-40.9	68
Frame Length	341.2	-36.2	305
Front Axle to Back of Cab	68.0	0	68
Front of Frame to Axle	36.2	-36.2	0
Load Space	237.0	68	305
Overall Length	345.9	-40.9	305
Overhang	75.0	230	305
Pusher Offset #1	0.0	230	230
Pusher Offset #2	0.0	230	230
Pusher Offset #3	0.0	230	230
Tag Offset	0.0	230	230
Wheelbase	230	0	230

# FRAME LAYOUT

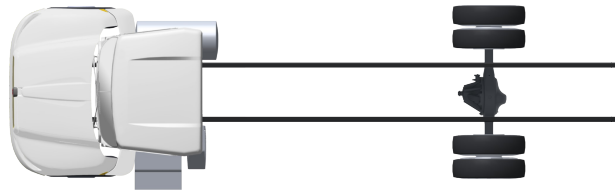

**Note:** Optional content may be displayed. The order has not yet received an engineering review. The actual arrangement of components may not be exactly as pictured. Additional changes may be made to the layout by Kenworth. Add a Custom Frame Layout code if an exact layout is required.

## Selected Options (Wheelbase: 230)

Sales Code	Description	Length	Side
7010075	Fuel Tank: 75 US gallon 22in. aluminum under	47.3	Right
7722011	Small round DEF tank, 11 gallons of	9.2	Left
6404411	Battery box: Narrow steel parallel under cab	26.5	Left



156 Epping Rd.  
 Exeter, NH 03833  
 (603)778-8158  
 www.netruckcenter.com

# Quote

Date	Estimate #
11/2/2020	434138

Name / Address
New England Truck Center 156 Epping Road Exeter, NH 03833

OP#	PO #
434138	

Item	Description	Qty	Total
MATERIAL	2022 BLACK KENWORTH T270 VIN# TBD	1	74,000.00
MATERIAL	2021 NRC 20TB-22' SERIAL# TBD	1	34,680.00
C-NC112	FULLY CONFIGURABLE EQUIPMENT	1	0.00
C-NC19	20 000TB	1	0.00
C-2022	22'-20 000-TB	1	0.00
C-NC46	COMPLETE EQUIPMENT	1	0.00
C-D414	4 CHAIN SLOTS PER SIDE (16 TOTAL FOR 21', 22', 23', 24')	1	0.00
C-D	"3/16" CHECKER PLATE DECK (STANDARD)	1	0.00
C-DISCLAIMER	CUSTOMER, FINAL PURCHASER OR END USER HAS BEEN INFORMED OF THE RISKS AND BENEFITS OF HOT DIP GALVANIZING (HDG) OF HIS NRC CAR CARRIER DECK	1	0.00
C-C3	FLAT TOP DECK WITH STAKE POCKET, WITHOUT REMOVABLE RAILS	1	0.00
C-B3	3" HIGH X 9" SPACING (OPTION FOR 20 000-TB)	1	0.00
C-L16	5 MARKER LIGHTS PER SIDE	1	0.00
C-T02	RAMSEY HDP 10,000 LBS WITH 7/16" X 75' WIRE ROPE (OPTION FOR 10 000-TB AND 20 000-TB)	1	0.00
C-T15	AIR CLUTCH RELEASE ON WINCH	1	0.00
C-NC30	75' WIRE ROPE	1	0.00
C-CR01	SWIVEL HOOK	1	0.00
C-NC44	MEDIUM DUTY STINGER AND WHEEL LIFT (STANDARD FOR 20 000-TB) (3X3 T-BAR)	1	0.00
C-NC24	SINGLE AXLE	1	0.00
C-G20	GALVANIZED SUB-FRAME AND BUMPER	1	0.00
C-L118	8 X 4 1/2" LIGHT (6 RED (STOP-FLASH) / 2 BACKUPS) - ON BUMPER	1	0.00
C-NC11	LEVER CONTROL STANDARDS	1	0.00
C-INCL	WHEEL LIFT SYSTEM (OPTION INCLUDES 3X3 T-BAR)	1	0.00
C-S052	STAINLESS ON REAR BUMPER	1	0.00
C-G011	STABILIZER GRIP (20,000) (3X3)	1	0.00
C-L112-1	2 LED WORK LIGHTS ON TOP OF THE REAR BUMPER	1	0.00
		<b>Total</b>	





156 Epping Rd.  
 Exeter, NH 03833  
 (603)778-8158  
 www.netruckcenter.com

# Quote

Date	Estimate #
11/2/2020	434138

Name / Address
New England Truck Center 156 Epping Road Exeter, NH 03833

OP#	PO #
434138	

Item	Description	Qty	Total
C-B06	HITCH RECEIVER ASSEMBLY 10-20 000LBS (2"X2")	1	0.00
C-12V	12V WIRING	1	0.00
C-A1	STANDARD CHAIN RACK	1	0.00
C-L118	8 X 4 1/2" LIGHT (6 RED (STOP-FLASH) / 2 BACKUPS) - ON CHAIN RACK	1	0.00
C-NC40	CHAIN RACK NRC BLACK PAINT	1	0.00
C-S093	STAINLESS ON SIDES AND HEAD OF CHAIN RACK	1	0.00
C-LO2P	WIRELESS REMOTE CONTROL LODAR 2 BUTTONS (WINCH)	1	0.00
C-A421	RECOVERY ROLLER GUIDE (ROLLBACK)	1	0.00
C-S056	STAINLESS ON OIL TANK	1	0.00
C-NC17	CLEAR MARKER LIGHT	1	0.00
C-NC110	WIRED TOWLIGHT ONLY	1	0.00
C-P-O	NO NEW CUSTOM REQUEST	1	0.00
C-NC26	"BLACK POLYMER CONTROL BOXES (STANDARD)	1	0.00
C-RACK5	68" [1727MM] - HEIGHT ABOVE FRAME RAILS [C#5]	1	0.00
C-PGAL-1	DECK GALVANIZED (OPTION FOR 18'-23' DECKS)	1	0.00
	UNCONFIGURABLE ITEMS		
DESTTRANSPORT	DESTINATION TRANSPORT CHARGE	1	1,300.00
DEALERINSTALL	DEALER INSTALL W/ PTO	1	6,650.00
ALGT70-INST	70" FEDERAL SIGNAL LIGHTBAR INSTALLED	1	2,050.00
TU823503-INST	48" STAINLESS TOOLBOX INSTALLED	3	2,983.02
TU824003-INST	60" STAINLESS TOOLBOX INSTALLED	1	1,049.34
SUBLET NETC	STANDARD STOCK PAINT / DETAIL	1	0.00
<b>Total</b>			\$122,712.36

ONCE THE BUYER ACCEPTS THIS ORDER, THE BUYER'S DEPOSIT IS NOT REFUNDABLE UNLESS THE BUYER CANNOT TAKE DELIVERY OF SAID VEHICLE(S) FOR A REASON BEYOND THE BUYER'S CONTROL. IN THAT EVENT, THE DEALER MAY, BUT WILL NOT BE REQUIRED TO, RETURN THE DEPOSIT TO THE BUYER, LESS ANY EXPENSES WHICH THE DEALER HAS INCURRED IN ACCEPTING AND PROCESSING THIS ORDER. THE BUYER'S FAILURE TO OBTAIN FINANCING BEFORE SCHEDULED DELIVERY IS NOT A REASON BEYOND THE BUYER'S CONTROL. BY SIGNING THIS THE BUYER ACKNOWLEDGES HAVING READ AND AGREEING TO THESE TERMS AND CONDITIONS.