



TalkTalk

Strategy Day

Charles Dunstone, *Chairman*

TalkTalk
Group

TalkTalk
Technology

AOL
Broadband.

TalkTalk
Brighter Phone & Broadband

o2

Building the business

Growth in 2009-10

- Customer base from 2.8 million to 4.2 million
- EBITDA up 27.1% to £230m
- Operating free cash-flow up £88m to £128m

Year ahead :

- 140-180,000 net adds
- Revenue growth 6-8%
- EBIT growth c. 20%
- Operating free cash-flow growth > 20%
- Dividend growth c. 20%

Building the business

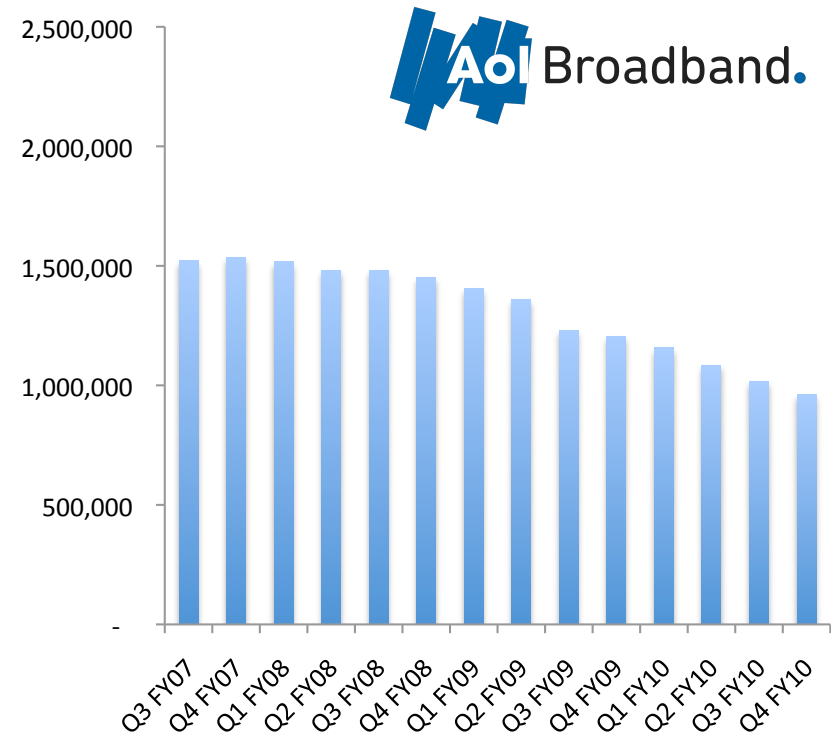
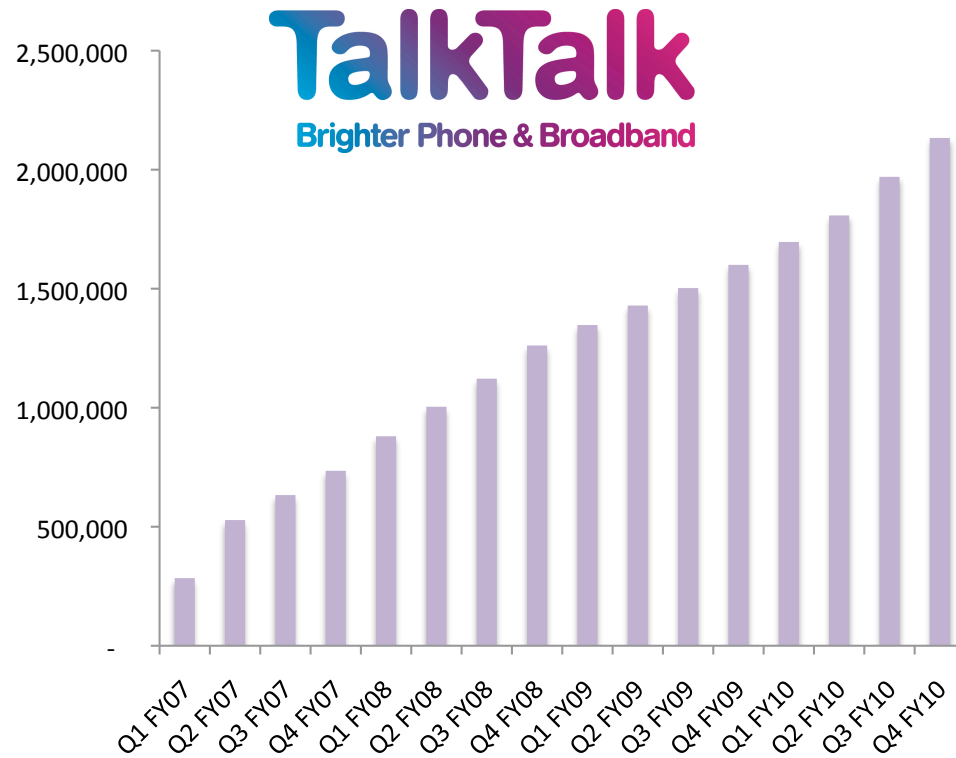

Building the business

tiscali.

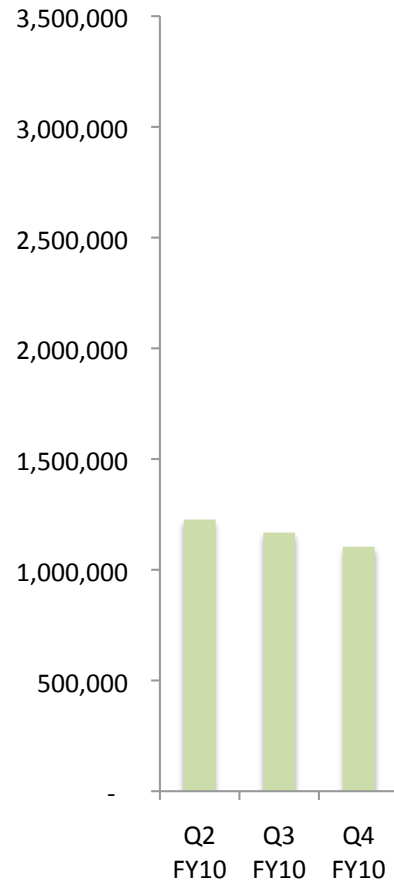

TalkTalk
Brighter Phone & Broadband

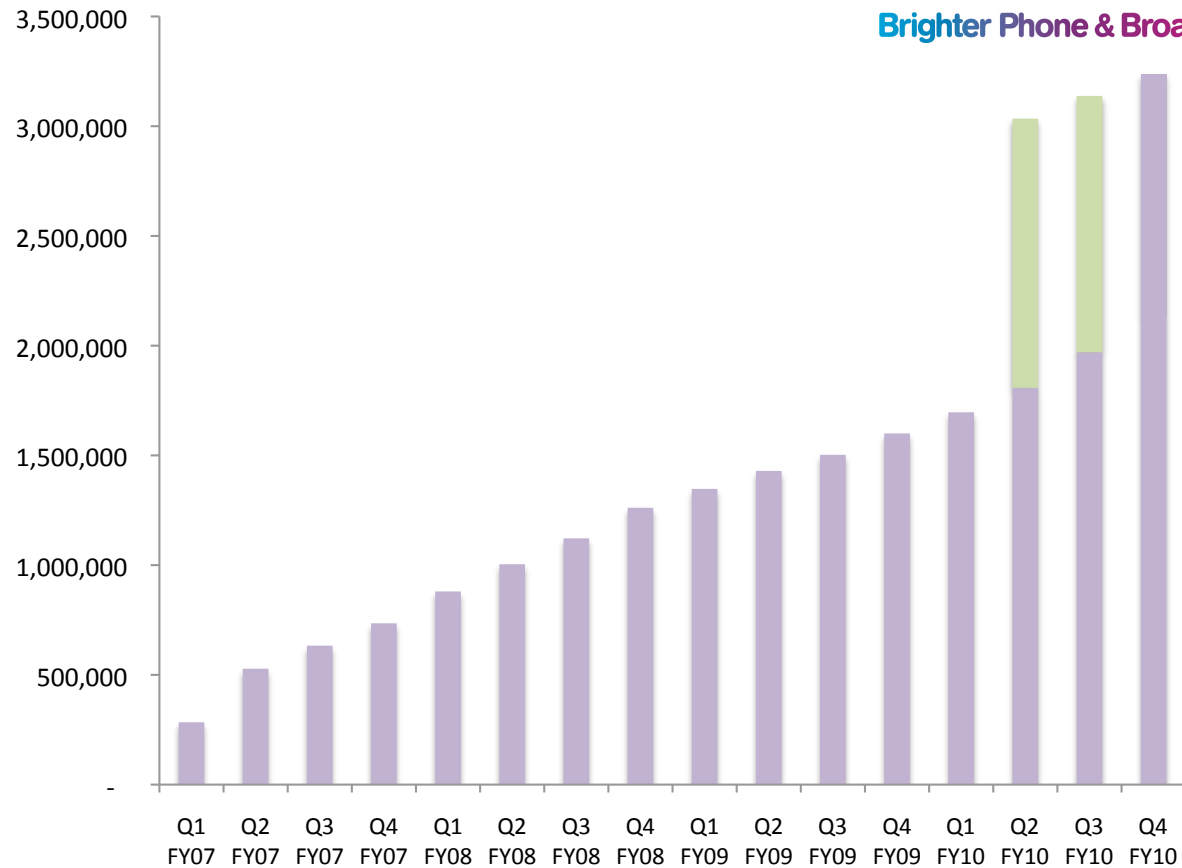

Value for money propositions

Essentials

All the phone and broadband you need, plus lots more you'll really want, all at a tiny price.

- ▶ The fastest possible speed - that's up to 24Meg
- ▶ Generous 40GB download allowance
- ▶ Evening and weekend calls to all UK landlines (including 0870/0845 numbers)
- ▶ FREE technical & customer support
- ▶ FREE wireless 'G' router

FREE for 3 months then £6.99 a month thereafter
 +£11.49 line rental (cheaper than BT)
 Save up to £164 vs BT

[Find out more](#)

[Buy now](#)

| Compare | TalkTalk Essentials | Virgin XL* | BT Option 2 |
|----------------------------------|---------------------|-------------|-------------|
| Speed | Up to 24Meg | Up to 20Meg | Up to 20Meg |
| Download Allowance (FUP) | 40GB | Unlimited | 20GB |
| Monthly cost (incl. line rental) | £20.48 | £35.44 | £32.53 |
| 12 month totals | £275.75 | £420.28 | £390.36 |
| Savings incl connection fee | | £144.53 | £160.00 |

Pro

A bright idea for families and busy households that demand more from their phone and broadband.

- ▶ The fastest possible speed - that's up to 24Meg
- ▶ Unlimited downloads
- ▶ Unlimited, anytime calls to all UK landlines (including 0870/0845 numbers)
- ▶ FREE technical & customer support
- ▶ FREE wireless 'N' router
- ▶ Call UK mobiles for 7p/min flat rate

£14.99 a month
 +£11.49 line rental (cheaper than BT)
 Save up to £171 vs BT

[Find out more](#)

[Buy now](#)

| Compare | TalkTalk Pro | Virgin XL* | BT* |
|---|--------------|-------------|-------------|
| Speed | Up to 24Meg | Up to 20Meg | Up to 20Meg |
| Download Allowance (FUP) | Unlimited | Unlimited | Unlimited |
| Monthly cost (incl. line rental) & security | £28.48 | £42.94 | £41.02 |
| 18 month totals | £542.63 | £740.92 | £714.36 |
| Savings incl connection fee | | £198.29 | £171.73 |

Strategy day agenda

Session 1

- Building the business
- CEO - introduction & objectives
- Regulatory & market developments
- TalkTalk's Next Generation Network
Q&A

Charles Dunstone
Dido Harding
David Goldie
Neil McArthur

Session 2

- Residential business
- B2B business
- Integration programme
- CFO – financial review & guidance
Q&A

Tristia Clarke
Paul Lawton
Mel Smith
Amy Stirling

Building the

TalkTalk

Business

Introduction & objectives

Dido Harding

Chief Executive Officer

Introduction & objectives

- My background
- First impressions
- Key priorities
 - Get to know the business & team
 - Deliver 2010/11 plan
 - Shape the future

Market & Regulatory

David Goldie

Director, Group Commercial

Political & Regulatory – The Customer Champion

- Competition Commission appeal - 2009 LLU/MPF price rises
- Digital Economy Bill
 - Illegal file-sharing – obligations on ISP's
 - 50p phone tax
- BT's Pension Deficit
- Mobile Termination Rates
- Next Generation Access - Fibre

Fibre – 4 Key Questions

- What will be the level of demand for FTTC and FTTP?
- Who will the fibre infrastructure providers be?
- Is the BT Openreach product sufficiently flexible to meet our customers' needs?
- Is there a favourable commercial structure from BT Openreach?

Who will the Fibre infrastructure providers be?

- Range of emerging third-party infrastructure
- Significant committed public sector investment and European funding with open access models eg:
 - S. Yorks
 - Manchester
- Property Developers
- Specialist and Community-based organisations

Openreach Flexibility? - Improving

| Flexibility for ISP | LLU | GEA Fibre |
|--|-----|-----------|
| Commercially viable third-party/self-install | ✓ | ✓ |
| Self-supply modem | ✓ | x |
| Self-supply router / CPE | ✓ | ✓ |
| Control of up and down stream speed | ✓ | ✓ |
| Dynamic line management control | ✓ | ✓ |
| QOS to support IP-Telephony and Video | ✓ | ✓ |
| Comprehensive fault diagnosis tools | ✓ | ✓ |
| Price independent of speed delivered | ✓ | ✓ / x |

Commercial Structure – Entry Level Product

| £/customer/month | Essentials ADSL2+ | Notional FTTC | BT Infinity 40/2Mb |
|--------------------------|----------------------|---------------|-----------------------|
| Price (incl. VAT) | | | |
| • Broadband | 6.99 | 6.99 | 19.99 |
| • Fibre charge (example) | - | 8.11 | |
| • Line rental | 11.49 | 11.49 | 11.54 |
| Total Price | 18.48 | 26.59 | 31.53 |
| Costs (incl. VAT) | | | |
| MPF rental | 8.86 | 8.86 | |
| GEA fee | - | 8.11 | |
| Total Costs | 8.86 | 16.97 | |
| Gross margin | 9.62 | 9.62 | |

Note: Margin excludes shared network costs, and also excludes additional ARPU for calls and boosts etc.
Pricing is only illustrative as retail prices have not been set.

Summary – Next Generation Access

- The scale of demand for fibre based services is not clear
- There will be diverse infrastructure providers
- Progress has been made with Openreach on product flexibility and discussions continue.
- TalkTalk Group's scale and Next Generation Network provides sustainable competitive advantage in Next Generation Access

TalkTalk's Next Generation Network

Neil McArthur

Chairman, TalkTalk Technology

What is a “Next Generation Network”

“Service-related functions are independent from underlying transport-related technologies”

Applications

Service control
(Network Intelligence)

Conveyance

- End-to-end IP-based
- Q-o-S enabled
- Manages multiple services
- Accelerates innovation
 - Can build new services without changing the infrastructure

TalkTalk's NGN

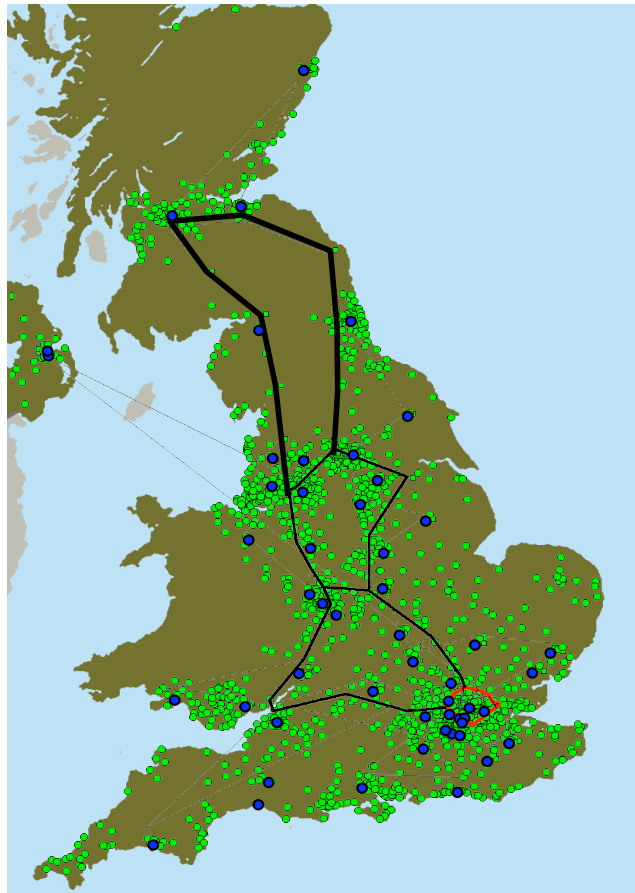

- 2 x 400 Gigabit UK core network
- Gigabit access to 1000+ exchanges
- 1748 enabled MPF & SMPF exchanges
- On track for 2000 by end-2010
- 89% of the population covered
- UK's deepest built multi-service NGN
- Conveys 200 GBits/second data
- More VoIP traffic than any other UK network
 - 11 Gbits/second
 - 1.6 Billion total minutes

TalkTalk NGN benefits

- Efficiently manages multiple services (Q-o-S enabled)
- Provides flexibility to offer wide range of products/services
 - Residential, B2B, carrier, wholesale, mobile
- Enables fast, efficient development of new services:
 - Parental controls, IPTV, Ethernet, 3G offload and backhaul
- Scalable – rapid & low-cost capacity expansion
- Low operating costs

Where “Next Generation Access” fits

TalkTalk’s “Next Generation Network”

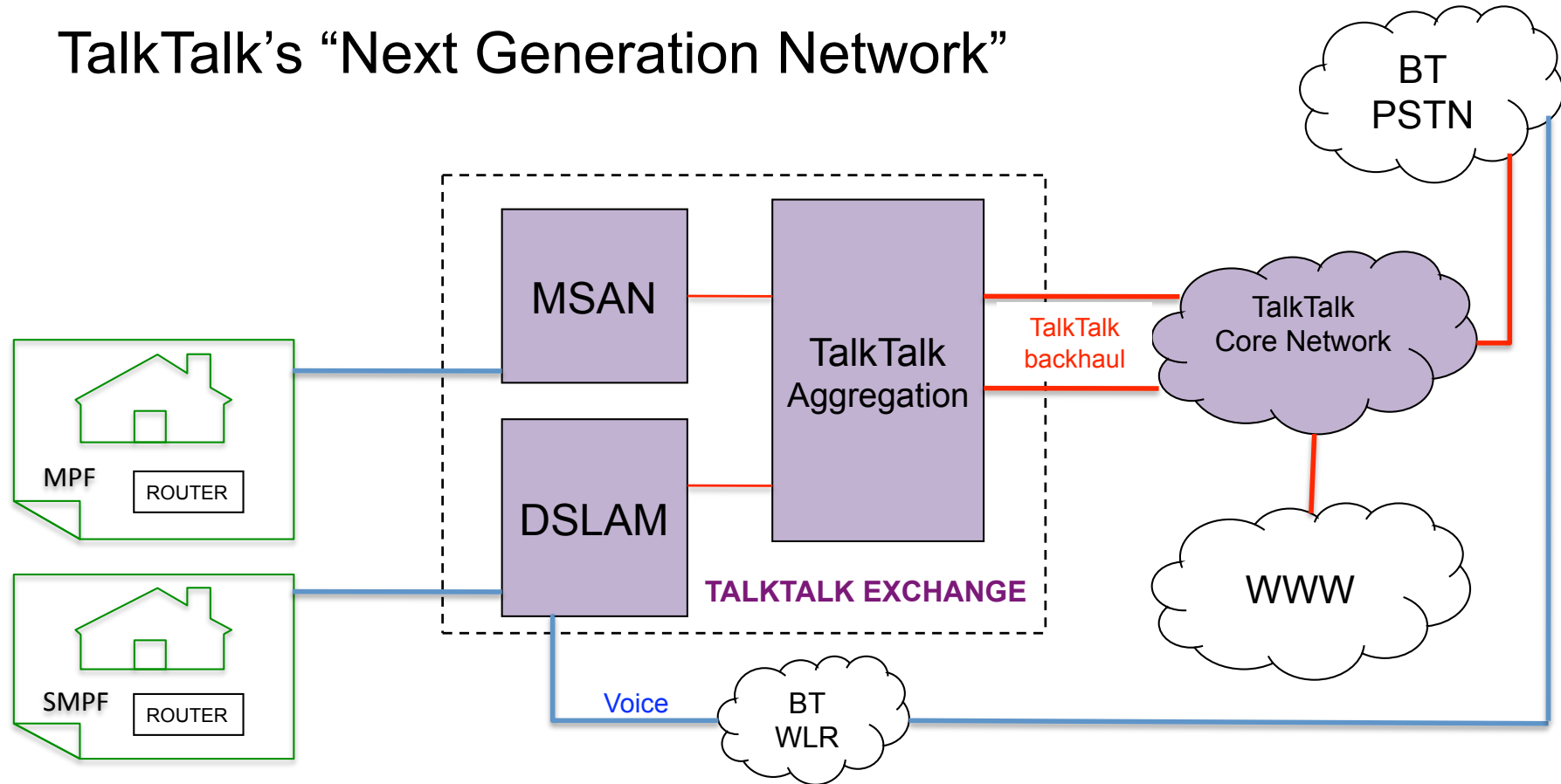

Where “Next Generation Access” fits

Adding FTTC

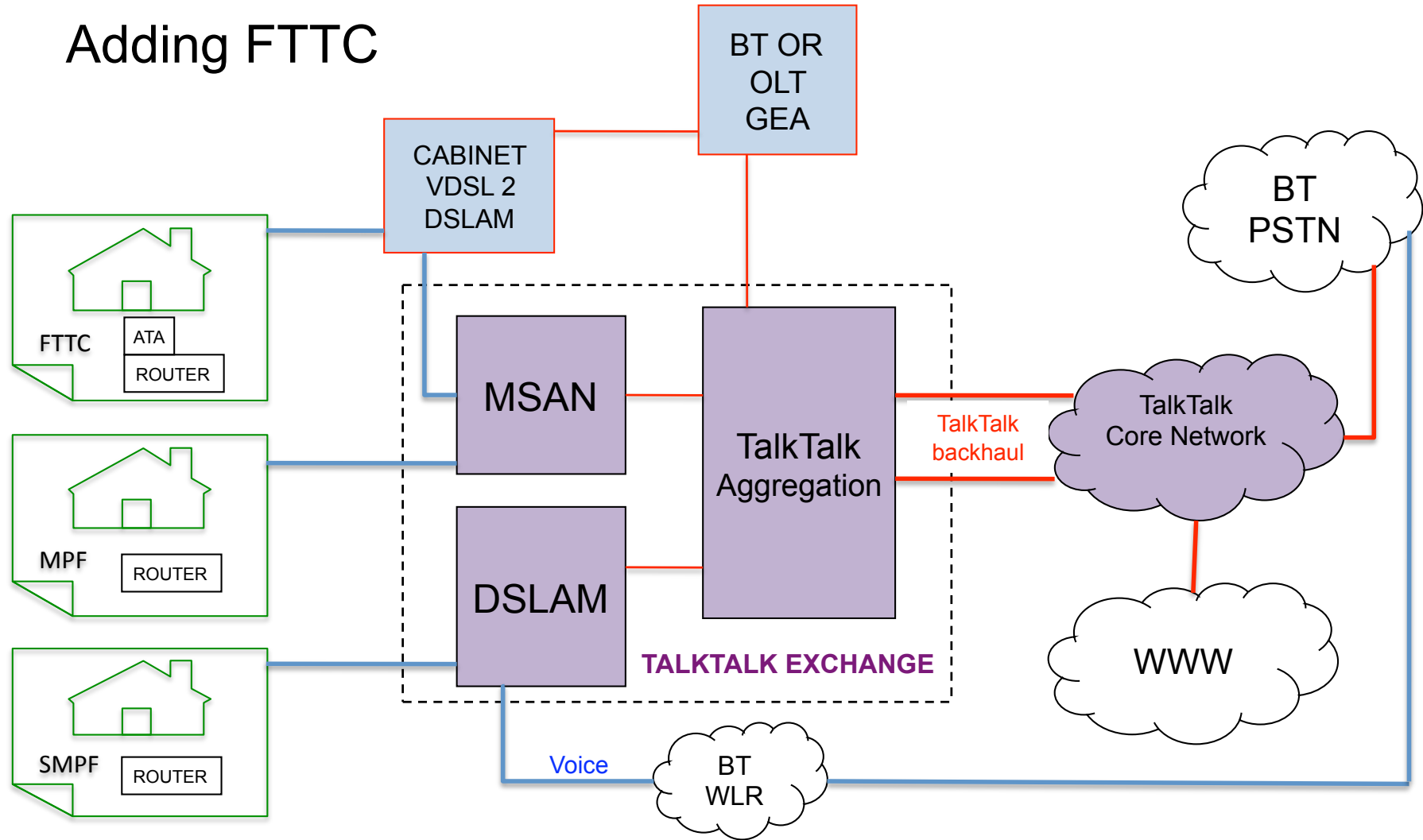

Where “Next Generation Access” fits

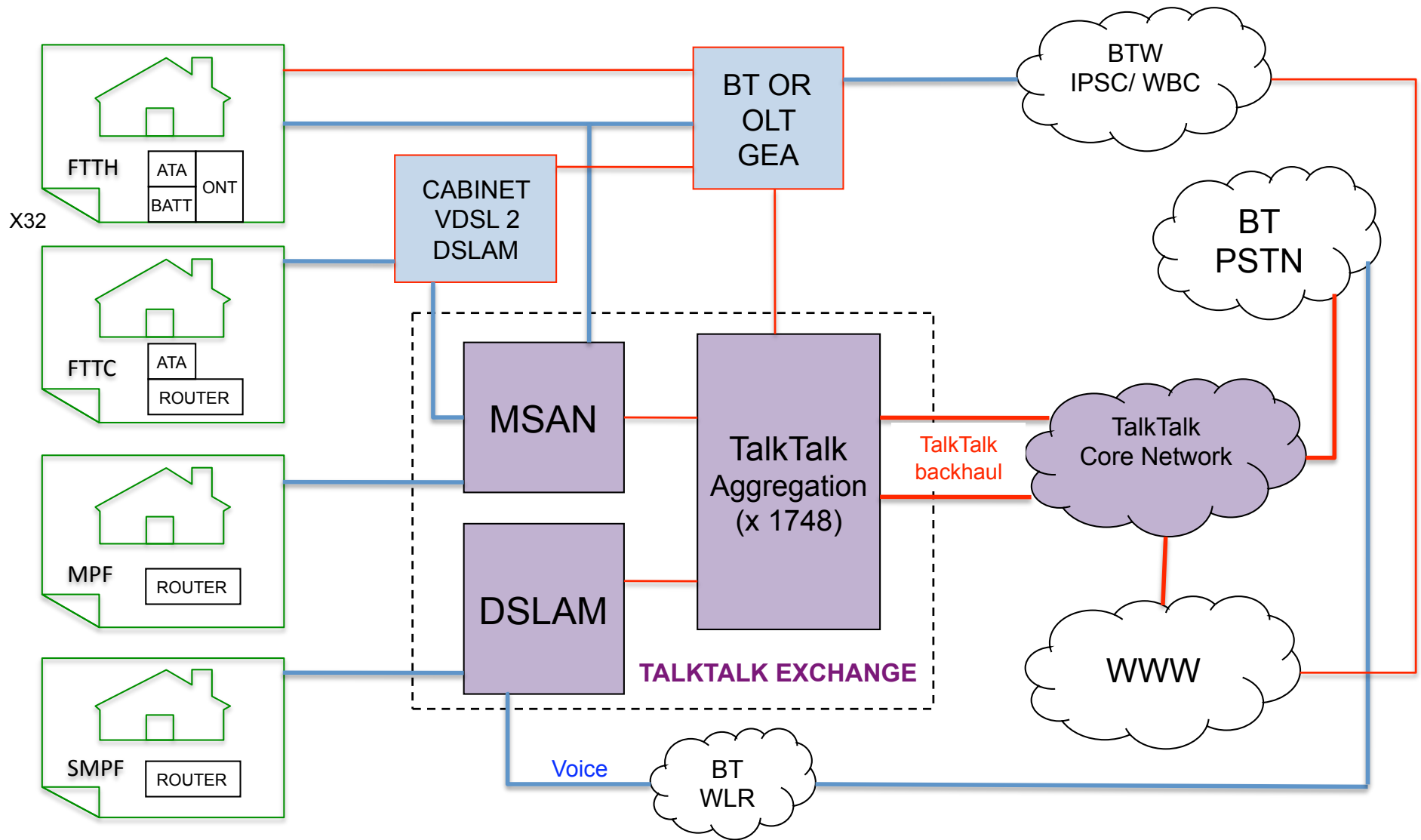

Bandwidth costs falling

