

**STRENGTH AND PERFORMANCE OF FIBER-REINFORCED
CONCRETE COMPOSITE SLABS**

By:

Marcela Guirola

**Thesis submitted to the faculty of the
Virginia Polytechnic Institute and State University
In partial fulfillment of the requirements for the degree of**

**MASTER OF SCIENCE
IN
CIVIL ENGINEERING**

APPROVED:

Dr. Carin Roberts-Wollmann, Chairperson

Dr. W. Samuel Easterling

Dr. Richard Weyers

**October 2001
Blacksburg, Virginia**

Keywords: Composite slabs, composite beams and joists, shear connectors, fiber-reinforced concrete, push-out tests.

STRENGTH AND PERFORMANCE OF FIBER-REINFORCED CONCRETE COMPOSITE SLABS

By:

Marcela Guirola

(ABSTRACT)

The purpose of this research is to evaluate and compare the influence of four types of secondary reinforcement on various component strengths related to composite slabs. These components include the composite slab strength under uniform load, the strength of two types of shear connectors used with composite beams and joists, composite slab strength due to a concentrated load, and the flexural toughness and first-crack strength of fiber-reinforced concrete using ASTM C1018 (1998) standard test. The performance of the specimens reinforced with fibers are compared with that of the specimens reinforced with welded-wire fabric (WWF), with the purpose of determining if fiber-reinforced concrete can be used as an alternative to WWF.

ACKNOWLEDGEMENTS

I want to express my gratitude to all the people who in one way or another contributed to the development of this research. I would like to specially thank the members of my committee: Dr. Carin Roberts-Wollmann, Dr. W. Samuel Easterling and Dr. Richard Weyers; thank you for your patience and valuable help in instructing, guiding and supporting me throughout the duration of this project and during my years of study at this institution.

I would also like to thank Synthetic Industries for sponsoring this research at Virginia Tech and Mr. Greg Moody for his valuable help.

The experimental testing of this research was not possible without the help of many. Special thanks go to Brett Farmer, Dennis Huffman and Ricky Woods for their technical assistance and labor, and for making my lab days more enjoyable. To my classmates and good friends to whom I owe so much: Grace Shen, Ben Mason, Thad Chapman, Tom Traver, Jason Piotter, James Warmoth and Onur Avci: thank you for your generous and valuable help and for giving me so many happy memories worth to remember. The efforts of Denson Graham in fabricating coupon specimens and the valuable help of Bob Simonds in the ESM lab are very much appreciated. I extend my thanks to my fellow classmates and faculty members from whom I've learned so much.

Finally and most importantly, I am very grateful to my Mom and Daddy for always giving me their love and support. To other family and friends; particularly Carlos and Silvana, for giving me hope and cheering me up in the bad times. Thanks for always being there for me.

TABLE OF CONTENTS

ACKNOWLEDGEMENTS	iii
LIST OF FIGURES AND TABLES	vii
LIST OF SYMBOLS.....	xi
Chapter 1	1
INTRODUCTION.....	1
1.0 GENERAL	1
1.1 OBJECTIVE:.....	2
1.2 SCOPE:	2
1.3 THESIS ORGANIZATION	3
Chapter 2	5
LITERATURE REVIEW.....	5
2.1 COMPOSITE SLABS	5
2.2 PUSH-OUT TESTS	8
2.2.1 STANDOFF SCREWS IN PUSH-OUT TESTS.....	8
2.2.2 WELDED SHEAR STUDS IN PUSH-OUT TESTS.....	11
Chapter 3	14
COMPOSITE SLABS UNDER DISTRIBUTED LOAD.....	14
EXPERIMENTAL PROGRAM.....	14
3.1 TEST PARAMETERS	14
3.2 INSTRUMENTATION.....	15
3.3 TEST SETUP	15
3.4 TEST PROCEDURE.....	17
3.5 COMPONENT TESTS	17
3.6 RESULTS.....	17
3.6.1 WWF-1	19
3.6.2 WWF-2.....	20
3.6.3 XOREX25-1	21
3.6.4 XOREX25-2.....	22
3.6.5 XOREX50-1	23
3.6.6 XOREX50-2.....	24
3.6.7 MICROFIBER MD-1	25
3.6.8 MICROFIBER MD-2.....	26
3.7 EVALUATION OF RESULTS.....	28
3.7.1 First Yield Method and ASCE Standard for the Structural Design of Composite Slabs –Appendix D Method	28
3.7.2 Comparison of Experimental and Theoretical Results.....	32
3.8 CONCLUSIONS	34
Chapter 4	35
ASTM C1018- Standard Test Method for Flexural Toughness and First-Crack Strength of Fiber-Reinforced Concrete.....	35
4.0 GENERAL	35
4.1 TEST PARAMETERS	37
4.2 INSTRUMENTATION.....	37
4.3 TEST SETUP	37

4.4 TEST PROCEDURE.....	39
4.5 COMPONENT TESTS	39
4.6 RESULTS.....	40
4.6.1 Calculations Method.....	40
4.6.2 Summary of Results	41
Chapter 5	44
COMPOSITE SLABS UNDER CONCENTRATED LOADS.....	44
5.1 TEST PARAMETERS	44
5.2 INSTRUMENTATION.....	45
5.3 TEST SETUP	45
5.4 TEST PROCEDURE.....	47
5.5 COMPONENT TESTS	49
5.6 RESULTS.....	49
5.6.1 WWF	50
5.6.2 XOREX-25	52
5.6.3 XOREX-50	54
5.6.4 Microfiber-MD	56
5.7 EVALUATION OF RESULTS.....	58
5.8 CONCLUSIONS	68
Chapter 6	69
PUSH-OUT TESTS	69
6.1 TEST PARAMETERS	69
6.2 INSTRUMENTATION.....	70
6.3 TEST SETUP	70
6.4 TEST PROCEDURE.....	72
6.5 COMPONENT TESTS	72
6.6 RESULTS.....	72
6.7 EVALUATION OF RESULTS.....	73
6.7.1 ELCO Grade-8 Standoff Screws Shear Capacity Method (Mujagic et al. 2000)	73
6.7.2 Theoretical Shear Strength Capacity for Headed Studs; AISC Method and Rambo-Roddenberry et al. (2001).....	75
6.8 CONCLUSIONS	77
Chapter 7	78
SUMMARY, CONCLUSIONS AND RECOMMENDATIONS	78
7.1 SUMMARY	78
7.2 CONCLUSIONS.....	79
7.3 RECOMMENDATIONS FOR FUTURE RESEARCH	81
REFERENCES.....	82
APPENDIX A: WWF-COMPOSITE SLABS UNDER DISTRIBUTED LOAD TEST PLOTS	86
APPENDIX B: XOREX-25-COMPOSITE SLABS UNDER DISTRIBUTED LOAD TEST PLOTS	96
APPENDIX C: XOREX-50-COMPOSITE SLABS UNDER DISTRIBUTED LOAD TEST PLOTS	104

APPENDIX D: Microfiber-MD-COMPOSITE SLABS UNDER DISTRIBUTED LOAD	
TEST PLOTS	114
APPENDIX E:.....	123
ASTM C1018 STANDARD TEST SUMMARY OF RESULTS.....	123
SUMMARY OF RESULTS FOR XOREX-25	124
SUMMARY OF RESULTS FOR XOREX-50	125
SUMMARY OF RESULTS FOR MICROFIBER-MD.....	127
APPENDIX F	129
COMPOSITE SLABS UNDER NON-DISTRIBUTED LOADS TEST DATA.....	129
Slab: WWF	131
Slab: XOREX-25.....	148
Slab: XOREX-50.....	165
Slab: Microfiber-MD.....	183
APPENDIX G	194
PUSH-OUT TESTS SUMMARY OF RESULTS	194
TEST WWF-Screw-1 DATA.....	196
APPENDIX H	243
FIBER PROPERTIES	243
XOREX™-STEEL FIBER	244
FIBERMESH®	245
APPENDIX I.....	246
SAMPLE CALCULATIONS.....	246
VITA	249

LIST OF FIGURES AND TABLES

Figure 2.1 Transverse Centerline Strain Distribution In Composite Slabs During Concentrated Loading (Luttrell, 1995).....	7
Figure 2.2 Weak and Strong Stud Positions.....	12
Figure 3.1 Test Setup for Composite Slabs under Distributed Load.....	16
Table 3.1 Experimental Results.....	18
Figure 3.2 WWF-1 Applied Load vs. Mid-span Deflection and End Slip.....	19
Figure 3.3 WWF-2 Applied Load vs. Mid-span Deflection and End Slip.....	20
Figure 3.4 XOREX25-1 Applied Load vs. Mid-Span Deflection and End Slip.....	21
Figure 3.5 XOREX25-2 Applied Load vs. Mid-Span Deflection and End Slip.....	22
Figure 3.6 XOREX50-1 Applied Load vs. Mid-Span Deflection and End Slip.....	23
Figure 3.7 XOREX50-2 Applied Load vs. Mid-Span Deflection and End Slip.....	24
Figure 3.8 MICROFIBER MD-1 Applied Load vs. Mid-Span Deflection and End Slip ..	25
Figure 3.9 MICROFIBER MD-2 Applied Load vs. Mid-Span Deflection and End Slip ..	26
Figure 3.10 Applied Load vs. Mid-Span Deflection for Distributed Load Test on First Span of Slabs.....	27
Figure 3.11 Applied Load vs. Mid-Span Deflection for Distributed Load Test on Second Span of Slabs.....	27
Figure 3.12. Deck Cross Section and Force Locations.....	30
Table 3.2 Comparison of Experimental and Theoretical Results.....	32
Figure 3.13 Applied Load vs. Crack Width Over Interior Support.....	34
Figure 4.1- Characteristics of a Load-Deflection Curve.....	35
Figure 4.2 Test Setup for ASTM C1018 Test.....	38
Table 4.1 Summary of Results- ASTM C1018.....	41
Figure 4.3 – XOREX25- Load-Deflection Curves for ASTM C1018.....	42
Figure 5.1 Strain Gage and Displacement Transducers Locations.....	45
Figure 5.2 A- Test Setup for Concentrated Load Tests.....	46
Figure 5.2 B- Setup Detail for Concentrated Load Test (side view).....	46
Figure 5.2 C- Setup Detail for Line Load Tests (side view).....	46
Figure 5.3 (A)-(K) Concentrated and Line Load Locations.....	48
Figure 5.4- Cracks formed on both sides of the slab with WWF.....	50
Figure 5.5- WWF Slab Deflection with 10-kip Concentrated Load at Mid-Span.....	51
Figure 5.6- WWF Strain Along Span with 10-kip Concentrated Load at Mid-Span.....	51
Figure 5.7- XOREX25-Slab Deflection with 10-kip Concentrated Load at Mid-Span.....	52
Figure 5.8 XOREX25- Strain Along Span with 10k Concentrated Load at Mid-Span.....	53
Figure 5.9- XOREX50 Slab Deflection with 10-kip Concentrated Load at Mid-Span.....	54
Figure 5.10 XOREX50 Strain Along Span with 10k Concentrated Load at Mid-Span.....	55
Figure 5.11-Cracks formed on both sides of the slab with Microfiber-MD.....	56
Fig. 5.12 Microfiber-MD Slab Deflection with 10k Concentrated Load at Mid-Span.....	57
Figure 5.13- Microfiber-MD Strain Along Span with 10k Concentrated Load at Mid-Span.....	57
Table 5.2 Theoretical Moments Versus Observed Moments for Slabs under Concentrated Loads.....	58
Figure 5.14- Strain along Span’s Center Strip with 10 kip Concentrated Load at Mid-Span (Fig. 5.3-B).....	60

Figure 5.15- Strain across Mid-Span with 10 kip Concentrated Load at Mid-Span (Fig. 5.3-B).....	60
Figure 5.16- Deflection along Span’s Center Strip with 10 kip Concentrated Load at Mid-Span (Fig. 5.3-B).....	61
Figure 5.17- Deflection across Mid-Span with 10 kip Concentrated Load at Mid-Span (Fig. 5.3-B).....	61
Figure 5.18- Strain along Span’s Middle Strip with 15 kip Concentrated Load at Quarter Point (Fig. 5.3-A).....	62
Figure 5.19- Strain across Quarter Point with 15 kip Concentrated Load at Quarter Point (Fig. 5.3-A).....	62
Figure 5.20- Deflection along Span’s Middle Strip with 15 kip Concentrated Load at Quarter Point (Fig. 5.3-A).....	63
Figure 5.21- Deflection across Quarter Point with 15 kip Concentrated Load at Quarter Point (Fig. 5.3-A).....	63
Figure 5.22- Strain along Span’s Middle Strip with 10 kip Linear Load along Middle Strip (Fig. 5.3-F).....	64
Figure 5.23- Strain across Mid-Span with 10 kip Linear Load along Middle Strip (Fig. 5.3-F).....	64
Figure 5.24- Deflection along Span’s Middle Strip with 10 kip Linear Load along Middle Strip (Fig. 5.3-F).....	65
Figure 5.25- Deflection across Mid-Span with 10 kip Linear Load along Middle Strip (Fig. 5.3-F).....	65
Figure 5.26- Strain along Span’s Middle Strip with 10 kip Linear Load along Mid-Span (Fig. 5.3-I).....	66
Figure 5.27- Strain across Mid-Span with 10 kip Linear Load along Mid-Span (Fig. 5.3-I).....	66
Figure 5.28- Deflection along Span’s Middle Strip with Linear Load along Mid-Span (Fig. 5.3-I).....	67
Figure 5.29- Deflection across Mid-Span with 10 kip Linear Load along Mid-Span (Fig. 5.3-I).....	67
Table 6.1 Push-Out Test Specimens – Test Matrix.....	69
Figure 6.1-A Typical Top Chord Section (Alander et al. 1998).....	70
Figure 6.1-B Typical Test Setup (Alander et al. 1998).....	71
Figure 6.1-C Test Setup Detail (Alander et al. 1998).....	71
Table 6.2-A Push-out Tests Results for ELCO Grade 8 Standoff Screws.....	72
Table 6.2-B Push-out Test Results for 4- 3/8” Headed Studs.....	73
Figure 6.2 Deck Dimensions.....	74
Table 6.2- Theoretical and Test Results for Shear Strength Capacity per Screw.....	74
Table 6.3- Theoretical and Test Results for Shear Strength Capacity per Stud.....	77
Figure A.1 WWF-1 Applied Load vs. Mid-Span Deflection and End Slip.....	89
Figure A.2 WWF-1 Applied Load vs. Quarter Point Deflection.....	89
Figure A.3 WWF-1 Applied Load vs. Strain in Deck Top Flange along Span.....	90
Figure A.4 WWF-1 Applied Load vs. Strain in Deck Bottom Flange along Span.....	90
Figure A.5 WWF-1 Applied Load vs. Crack Width at Interior Support.....	91
Figure A.6 WWF-2 Applied Load vs. Mid-Span Deflection and End Slip.....	93
Figure A.7 WWF-2 Applied Load vs. Quarter Point Deflection.....	93

Figure A.8 WWF-2 Applied Load vs. Strain in Deck Top Flange along Span.....	94
Figure A.9 WWF-2 Applied Load vs. Strain in Deck Bottom Flange along Span	94
Figure A.11 WWF-2 Crack Over Interior Support	95
Figure B.1 XOREX25-1 Applied Load vs. Mid-Span Deflection and End Slip.....	98
Figure B.2 XOREX25-1 Applied Load vs. Quarter Point Deflection.....	98
Figure B.3 XOREX25-1 Applied Load vs. Strain in Deck Top Flange along Span.....	99
Figure B.4 XOREX25-1 Applied Load vs. Strain in Deck Bottom Flange along Span	99
Figure B.5 XOREX25-1 Applied Load vs. Crack Width at Interior Support	100
Figure B.6 XOREX25-2 Applied Load vs. Mid-Span Deflection and End Slip.....	102
Figure B.7 XOREX25-2 Applied Load vs. Quarter Point Deflection.....	102
Figure B.8 XOREX25-2 Applied Load vs. Strain in Deck Top Flange along Span.....	103
Figure B.9 XOREX25-2 Applied Load vs. Strain in Deck Bottom Flange along Span ..	103
Figure C.1 XOREX50-1 Applied Load vs. Mid-Span Deflection and End Slip.....	107
Figure C.2 XOREX50-1 Applied Load vs. Quarter Point Deflection.....	107
Figure C.3 XOREX50-1 Applied Load vs. Strain in Deck Top Flange along Span.....	108
Figure C.4 XOREX50-1 Applied Load vs. Strain in Deck Bottom Flange along Span ..	108
Figure C.5 XOREX50-1 Applied Load vs. Crack Width at Interior Support	109
Figure C.6 XOREX50-1 Crack Over Interior Support Test Designation: XOREX50-2	109
Figure C.6 XOREX50-2 Applied Load vs. Mid-Span Deflection and End Slip.....	110
Figure C.7 XOREX50-2 Applied Load vs. Quarter Point Deflection.....	111
Figure C.8 XOREX50-2 Applied Load vs. Strain in Deck Top Flange along Span.....	111
Figure C.9 XOREX50-2 Applied Load vs. Strain in Deck Bottom Flange along Span ..	112
Figure C.10 XOREX50-2 Applied Load vs. Crack Width at Interior Support	113
Figure C.12 XOREX 50-2 Crack Over Interior Support.....	113
Figure D.1 MicrofiberMD-1 Applied Load vs. Mid-Span Deflection and End Slip	117
Figure D.2 MicrofiberMD-1 Applied Load vs. Quarter Point Deflection	117
Figure D.3 MicrofiberMD-1 Applied Load vs. Strain in Deck Top Flange along Span..	118
Figure D.4 MicrofiberMD-1 Applied Load vs. Strain in Deck Bottom Flange along Span	118
Figure D.5 MicrofiberMD-1 Applied Load vs. Crack Width at Interior Support.....	119
Figure D.6 MicrofiberMD-2 Crack Over Interior Support	119
Figure D.6 MicrofiberMD-2 Applied Load vs. Mid-Span Deflection and End Slip	121
Figure D.7 MicrofiberMD -2 Applied Load vs. Quarter Point Deflection	121
Figure D.8 MicrofiberMD -2 Applied Load vs. Strain in Deck Top Flange along Span.	122
Figure D.9 MicrofiberMD -2 Applied Load vs. Strain in Deck Bottom Flange along Span	122
Table E.1 Summary of Results- XOREX 25.....	124
Figure E.1- XOREX25-Load vs. Deflection at 14 days.....	124
Table E.2 Summary of Results- XOREX-50 at 14 days	125
Figure E.2- XOREX50- Load vs. Deflection at 14 days.....	125
Table E.3 Summary of Results XOREX-50 at 45 days	126
Figure E.3-XOREX-50-Load vs. Deflection at 45 days	126
Table E.4 Summary of Results Microfiber-MD at 14 days	127
Figure E.4- Microfiber-MD-Load vs. Deflection at 14 days	127
Table E.5 Summary of Results Microfiber-MD at 45 days	128

Figure E.5-Microfiber-MD- Load vs. Deflection at 45 days	128
Figure F1-Strain Gage and Wire-Pot Locations across Mid-Span and Quarter-Points ...	129
Table F-1: Non-Distributed Load Tests Data for WWF Slab	131
Table F-2 Non-Distributed Load Tests Data for XOREX-25 Slab	148
Table F-3 Non-Distributed Load Tests Data on XOREX-50 Slab.....	165
Table F-4 Non-Distributed Load Tests Data on Microfiber-MD Slab.....	183
Table G-1 WWF-Screw-1 Test Data.....	196
Figure G-1 WWF-Screw-1 Applied Shear Load vs. Slip.....	197
Table G-2 WWF-Screw-2 Test Data.....	198
Table G-2 WWF-Screw-2 Test Data.....	199
Figure G-2 WWF-Screw-2 Applied Shear Load vs. Slip.....	200
Table G-3 XOREX25-Screw-1 Test Data.....	201
Figure G-3 XOREX25-Screw-1 Applied Shear Load vs. Slip.....	203
Table G-4 XOREX25-Screw-2 Test Data.....	204
Table G-4 XOREX25-Screw-2 Test Data.....	205
Figure G-4 XOREX25-Screw-2 Applied Shear Load vs. Slip.....	206
Table G-5 XOREX25-Weak Stud-1 Test Data	208
Figure G-5: XOREX25-Weak Stud-1 Applied Shear Load vs. Slip	209
Table G-6: XOREX25-Weak Stud-2 Test Data	211
Figure G-6: XOREX25-Weak Stud-2 Applied Shear Load vs. Slip	212
Table G-7: XOREX50-Screw-1 Test Data.....	214
Figure G-7: XOREX50-Screw-1 Applied Shear Load vs. Slip.....	215
Table G-8: XOREX50-Screw-2 Test Data.....	217
Figure G-8: XOREX50-Screw-2 Applied Shear Load vs. Slip.....	218
Table G-9: XOREX50-Weak Stud-1 Test Data	219
Table G-9: XOREX50-Weak Stud-1 Test Data	220
Figure G-9: XOREX50-Weak Stud-1 Applied Shear Load vs. Slip	221
Table G-10: XOREX50-Weak Stud-2 Test Data	223
Figure G-10: XOREX50-Weak Stud-2 Applied Shear Load vs. Slip	224
Table G-11: XOREX50-Strong Stud-1 Test Data.....	226
Figure G-11: XOREX50- Strong Stud-1 Applied Shear Load vs. Slip.....	227
Table G-12: XOREX50-Strong Stud-2 Test Data.....	229
Figure G-12: XOREX50-Strong Stud-2 Applied Shear Load vs. Slip.....	230
Table G-13:Microfiber-MD-Screw-1 Test Data	232
Figure G-13: Microfiber-MD Screw-1 Applied Shear Load vs. Slip.....	233
Table G-14: Microfiber-MD Screw-2 Test Data.....	235
Figure G-14 Microfiber-MD Screw-2 Applied Shear Load vs. Slip.....	236
Table G-15: Microfiber-MD Weak Stud-1 Test Data	238
Figure G-15: Microfiber-MD Weak Stud-1 Applied Shear Load vs. Slip.....	239
Table G-16: Microfiber-MD Weak Stud-2 Test Data	241
Figure G-16: Microfiber-MD Weak Stud-2 Applied Shear Load vs. Slip	242

LIST OF SYMBOLS

Δ	= mid-span deflection
ρ	= reinforcement ratio, $A_s / (bd)$
ϕ	= strength reduction factor =0.85
a	= depth of compressive strength block, $A_s F_y / 0.85f'_c b$
a_0	= unit steel strain in the deck steel for the center unit strip
A_{bf}	= area of deck bottom flange per foot of width
a_i	= relative magnitude of the strain in the center of each unit width
A_s	= area of deck per unit width
A_s	= cross-sectional area of steel shape
A_{sc}	= cross-sectional area of the stud or screw
B	= affected transverse width of the slab
b	= average width of the specimen, in., at the fracture (for ASTM C1018)
b	= unit width of slab
B_b	= width of deck bottom flange
b_b	= test slab width
B_e	= effective width
B_t	= width of deck top flange
C	= compressive force in the concrete
C_n	= bending coefficient for positive moment, n number of spans
C_s	= cell spacing
d	= distance from top of slab to centroid of steel deck
d	= average depth of the specimen, in., at the fracture (for ASTM C1018)
d_d	= depth of deck
D_w	= width of deck web
E_c	= modulus of elasticity of concrete
E_s	= modulus of elasticity of the steel
f'_c	= concrete compressive strength; psi.
f_c	= casting stress in the deck due to fresh concrete
F_u	= minimum specified tensile stress of the stud
F_u	= steel tensile strength
F_{ut}	= screw tensile strength
F_y	= steel yield stress
f_{yc}	= corrected steel yield stress
h	= depth of composite slab from top of concrete to bottom of deck
h_c	= depth of concrete cover (depth of concrete above deck)
h_r	= nominal rib height
H_s	= length of shear stud after welding
H_s	= screw height, in.
I_{10}	= toughness Index up to 5.5times the first-crack deflection
I_{20}	= toughness Index up to 10 times the first-crack deflection
I_5	= toughness Index up to 3.0 times the first-crack deflection
I_{avg}	= average of the cracked and un-cracked moments of inertia
K	= $K_3/(K_1 + K_2)$ = bond force transfer property
K_1	= $[d_d/7.8]^{0.5}$

K_2	= mechanical bond factor
K_3	= slab width factor
L	= clear span between supports
ℓ'	= length of shear span
ℓ_e	= length of embossment
ℓ_{nf}	= clear span length
ℓ_s	= vertical distance between screws in a rib; in.
L_{sp}	= length of shear plane
M_{conc}	= moment due to concrete weight per unit width of slab
M_{et}	= first yield moment per unit width
M_n	= predicted nominal moment capacity
M_t	= theoretical bending moment
M_{test}	= observed test moment
n	= modular ratio
N	= number of cells in test slab width = $12b_d/C_s$
N	= number of screws in one rib not to exceed 12
N_b	= length of embossment along its base
N_h	= number of horizontal elements in embossment pattern lengths
N_r	= number of stud connectors on a beam in one rib
N_t	= length of embossment along its top
N_v	= number of vertical elements in embossment pattern lengths
P	= maximum applied load indicated by the testing machine, lbf. (for ASTM C1018)
p_h	= embossment depth
p_h	= height of embossment, in.
p_s	= embossment intensity factor = $12(N_v\ell_e + N_h w)/s$ (for Type III)
R	= modulus of rupture, psi.
R_d	= strength coefficient or deck thickness influence on weakposition studs
R_n	= shear strength per screw, kips
R_p	= strength coefficient based on stud position
s	= length of repeating embossment pattern, in.
S_c	= positive composite section modulus
S_p	= positive deck section modulus transformed section
SRF	= stud reduction factor
t	= steel deck thickness
T	= tensile force in the deck
t_{tc}	= top chord thickness; in.
w	= embossment width, in.
W_D	= weight of concrete and deck
w_r	= average width of concrete rib
w_{r1}	= bottom rib width; in.
w_{r2}	= top chord width; in.
X	= transverse distance from the center of the load point
y_{cc}	= distance from neutral axis of composite section to top of slab

Chapter 1

INTRODUCTION

1.0 GENERAL

Today, the use of composite floor slab systems in steel framed buildings is common practice. Among the numerous advantages over reinforced concrete slabs, are the lightweight and the ease with which the steel deck is handled and erected. The deck also takes the place of temporary formwork for the fresh concrete, which saves time and reduces construction costs. Once the concrete has cured and the components become a composite system, the cold-formed steel deck serves as positive slab reinforcement.

Even though the concept of composite slabs began in the 1920's, the first application to take advantage of this concept did not take place until the middle 1950's. To develop bond between the concrete and the steel deck, the first system utilized shear wires welded directly onto the ribs of the steel section (Luttrell, 1995). The main problems associated with this method were the expensive and time consuming welding process, and that the decks couldn't be "nested" for shipping purposes.

Embossments were added to the steel deck profiles in the 1960's. In 1967, the American Iron and Steel Institute (AISI) initiated a research project at Iowa State University with the purpose of obtaining design criteria for composite slab systems. Design criteria and specifications for composite slab systems were incorporated for the first time in the ASCE "Specifications for the Design and Construction of Composite Slabs" (ASCE 1992). The Steel Deck Institute (SDI) funded several research projects thereafter. As a result of the new research, a new method was developed for determining the strength of composite slabs, and was presented in the SDI "Composite Deck Design Handbook" (CDDH) (Heagler et al. 1993).

In common practice, welded wire fabric (WWF) is used as secondary reinforcement for temperature and shrinkage in concrete slabs. One of the problems associated with WWF, is the time involved in positioning the wire mesh correctly. An alternative to WWF is the use of fiber reinforced concrete where a specific amount of fibers is mixed with the fresh concrete. This method reduces shipping costs and eliminates the time consuming and costly labor of placing the wire mesh. The objective of this research is to compare the structural performance of slabs with fiber reinforced concrete to slabs with WWF as secondary reinforcement.

1.1 OBJECTIVE:

The objective of this project is to evaluate and compare the influence of four types of secondary reinforcement on various component strengths related to composite slabs. These components include the composite slab strength under uniform load, the strength of two types of shear connectors used with composite beams and joists, composite slab strength due to a concentrated load, and the “Flexural Toughness and First Crack Strength of fiber reinforced concrete” (ASTM C1018, Standards 1998). The relative serviceability performance with respect to the control of shrinkage and temperature cracks is not addressed in this work. The effect of the fibers in adhesion properties of the finished slab or mechanical bonding between the concrete and the steel deck were not considered.

1.2 SCOPE:

In the first set of tests four three-span composite floor slabs were constructed and tested under uniform load. All specimens were constructed with 20 ga, 2 in. rib height steel deck, 4.5 in. slab thickness and consisted of two deck panels for a width of approximately 6 ft. Concrete was all normal weight, with a nominal compressive strength of 3000 psi. The only variable in each specimen was the type of temperature and shrinkage reinforcement. The types of temperature and shrinkage reinforcement used were 6x6 W2.9xW2.9 WWF, 1.5 in. XOREX steel fibers in the amounts of 25 lb/yd³ and 50 lb/yd³ and synthetic fibers (Microfiber-MD) in the amount of 1.5 lb/yd³. Fiber properties are presented in Appendix H.

In the second set of tests, four 10 ft single-span composite floor slabs were constructed and tested under concentrated loads. All specimens were constructed with 20 ga, 2 in. rib height, 5.5 in. slab thickness and consisted of three deck panels for a width of approximately 9 ft. Concrete was all normal weight, with a nominal compressive strength of 3000 psi. Again, the only variable was the type of temperature and shrinkage reinforcement.

In the push-out tests, two sets of 3 ft x 3 ft specimens were constructed. The first set was built with 22 ga steel deck with a 1.5 in. rib height and 3.5 in. total slab depth. Shear connectors were ELCO Shear Flex standoff screws. The only variable in the specimens was the type of temperature and shrinkage reinforcement. All four types of temperature and shrinkage reinforcement were used. The second set of specimens was built with 20 ga steel deck with 2 in. rib height and 6 in. total slab depth. Welded studs were placed in the weak position of the rib in three of the four groups of specimens (Figure 2.2, Table 6.1). The type of fiber was the only variable in these specimens. No WWF was used. An additional group of specimens was constructed with the 50-lb/yd³ XOREX steel fiber mixture in which the studs were placed in the strong position of the rib (Figure 2.2).

Concrete beams were cast with each of the three fiber mixtures for the ASTM C1018 “Standard Test for Flexural Toughness and First-Crack Strength of Fiber-Reinforced Concrete” (ASTM Standards, 1998). The beams were 4”x4”x14”.

1.3 THESIS ORGANIZATION

Previous related research is presented in the Literature Review in Chapter 2. The experimental research related to the composite slabs tested under uniform load conditions is described in Chapter 3. This chapter also includes the analysis of the experimental results for this set of tests and a description of the First Yield Method and the ASCE Appendix D Alternate Method. The results and comparisons for the ASTM-C1018 “Standard Tests Method for Flexural Toughness and First-Crack Strength of Fiber-Reinforced Concrete” are presented in Chapter 4. The experimental research and results analysis of the composite slab specimens tested under concentrated and linear load

conditions are presented in Chapter 5. Push-out tests experimental research, results and analysis are presented in Chapter 6. Chapter 7 summarizes the results from all four sets of tests. Conclusions and recommendations are also given in this chapter. The details of each test specimen are provided in the appendices.

Chapter 2

LITERATURE REVIEW

2.1 COMPOSITE SLABS

The behavior of composite slabs has been thoroughly studied in past years. Based on results of this research both the SDI and ASCE have published design methods (“The Steel Deck Institute Method for Composite Slab Design” and the ASCE “Standard for the Design of Composite Slabs”). The majority of previous research has dealt with line loaded or uniformly loaded specimens using welded wire fabric (WWF) as the secondary reinforcement. In composite slab construction, the deck provides the primary tension reinforcement. In the negative moment region, it is assumed to have a zero nominal moment unless negative reinforcement is added, allowing the assumption of simple span behavior. The WWF is used for temperature and shrinkage reinforcement only and not for strength.

An early series of tests investigating the behavior of composite slabs was initiated at Iowa State University in 1967. The specimens tested were simply supported and single span, which was not fully representative of as built conditions (Luttrell, 1995).

In the early 1980’s the Steel Deck Institute (SDI) sponsored research at West Virginia University, which represented more realistic conditions. This set of tests included effects of end restraints and welded wire mesh reinforcement. Multi-panel slabs were also studied (Heagler et al, 1993). Tests concerned with non-uniform loads were conducted at Iowa State University and University of Washington, Seattle. These tests revealed the inadequacy of existing theories at the time related to non-uniform loads on composite slabs (Roeder, 1981; Porter, 1985).

A series of projects were conducted for the SDI at Virginia Tech (Young and Easterling, 1990, 1992; Terry and Easterling, 1994). Three span specimens were used and

each end span was uniformly loaded. This research focused on end restraint conditions (Terry and Easterling, 1994).

In 1994, a series of tests were conducted at McGill University in Canada investigating the effectiveness of steel fiber reinforcement in composite slabs; focusing primarily on the serviceability parameter of crack width (Ibrahim and Jannoulakis, 1994). The tests consisted of different specimens reinforced with varying quantities of steel fibers and a set of equivalent specimens reinforced with conventional wire mesh. The variable parameter in each set was the secondary reinforcement; either wire mesh or percentage of steel fibers. For each type of reinforcement, a total of six specimens were created with changes in slab depth, deck gauge and flute depth. Specimens reinforced with steel fibers were compared to equivalent specimens reinforced with WWF. From this set of experiments, it was concluded that as the proportion of steel fibers increased, the crack widths decreased. It was also found that crack widths were smaller in specimens reinforced with fibers than in those reinforced with WWF (Ibrahim et al, 1994). The specimens in this series of tests were uniformly loaded.

In 1995, a set of full-scale tests was performed at West Virginia University studying the transverse distribution of non-uniform loads in composite slabs (Luttrell, 1995). In this study, six different slabs were built. Four were loaded with concentrated loads at quarter points or at the center; the other two were loaded with a line load along the longitudinal centerline. Different slab depths were also considered. From these tests, Luttrell studied the load distribution effect in composite slabs. In the first step of his approach, a relationship was developed that described the observed strain for any unit width of slab relative to the unit steel strain for the center strip, as illustrated in Fig. 2.1. Equation 2-1 describes the developed relationship.

$$a_i = a_0[\cos\pi(x/B)]*[1 - 2(x/B)] \quad (2-1)$$

Where,

a_0 = unit steel strain in the deck steel for the center unit strip

a_i = relative magnitude of the strain in the center of each unit width

B = affected transverse width of the slab

x = transverse distance from the center of the load point

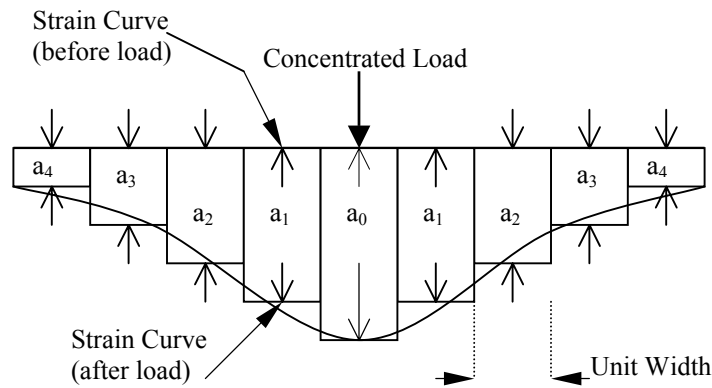

Figure 2.1 Transverse Centerline Strain Distribution In Composite Slabs During Concentrated Loading (Luttrell, 1995)

Values for the theoretical width of the slab, B that was affected by the load were found by iteration for each individual slab tested. A second equation was then developed that would approximate the B values (in feet) that had previously been determined:

$$B_{th} = 22 \frac{h_c}{h} \quad (2-2)$$

where,

h_c = depth of concrete cover (depth of concrete above deck)

h = total slab depth

Using the theoretical and specific bending moments, M_t (ASCE, 1992), the maximum steel strain, a_0 , was established. Relative strain values, a_i , were established for the unit width strips parallel to the one containing a_0 . The maximum theoretical moments due to concentrated loads for the full slab width, M_{th} , were developed through the summation of a_i 's; such that:

$$B_e = \sum a_i$$

$$M_{th} = B_e M_t \quad (2-3)$$

Where:

M_t = theoretical bending moment per unit width

B_e = effective width

The results obtained in Luttrell's tests were such that the ratio of the actual applied maximum moment and the theoretical maximum moment obtained from his equations, was approximately equal to one. The equations were also applied to the specimens loaded with line loads; the experimental results were also very similar to the theoretical ones. His work once again showed the inadequacy of the current ASCE design standard, which underestimates the ability of composite slabs to distribute concentrated and longitudinal linear loads (Luttrell, 1995).

Prior to Luttrell's investigation; there was another study in 1993 at West Virginia University, which dealt with concentrated loads. The results from this investigation were very similar to those obtained at Iowa State University in the 1980's (Mullenex, 1993).

Luttrell's work has been perhaps the most important research related to non-uniform loading conditions and his equations will be used in the work presented in this report. In relation to fiber-reinforcement in composite slabs, an important predecessor to the work presented in this report is the study performed at McGill University in 1994 by Ibrahim and Jannoulakis.

2.2 PUSH-OUT TESTS

2.2.1 STANDOFF SCREWS IN PUSH-OUT TESTS

The performance of standoff screws (ELCO Shear-Flex®) has been studied for the past eleven years, with most of the research conducted at Virginia Tech. The use of standoff screws as shear connectors for composite slabs and joists is a relatively new application of component members that is just beginning (2001) to be used in practice.

Different methods have been used to calculate the strength of the screw shear connector. Lauer et al. (1994) back calculated the strength of the screws using equilibrium equations for composite flexural members. Hankins et al. (1994) used existing models for

shear studs as well as the method previously developed by Oehler in 1989, which proved to be acceptable as long as the indirect tensile strength of concrete is taken as $6\sqrt{f'_c}$. The model developed by Lloyd and Wright in 1990 was also used but it failed to predict the shear connector strength accurately. The basis for this model is another model previously developed by Hawkins and Mitchell in 1984. Hawkins et al. consequently developed a modified version of the model proposed by Lloyd and Wright. This model showed to predict the strength of the standoff screw with acceptable accuracy. Alander et al. used the model developed by Hankins et al. and studied its applicability to other configurations. A new equation was obtained that accurately predicted the strength of the shear connection using ELCO Grade 8 standoff screws. However, his model had too many limitations and therefore needed to be modified. In 2000 Webler et al. developed new equations, which included additional variables such as number of screws per rib. He developed an equation that predicts the screw strength at a slab to joist slip value of 0.200 in. regardless of the failure mode at ultimate load. Equations for different failure modes were also developed in this model. Mujagic (2000) developed a new model, which considered three different types of failure: screw pullout failure, concrete rib failure and screw shear failure. Mujagic (2000) reported a series of push-out tests and developed a model that predicts the shear strength per screw. In his study, he also included the results of other tests performed in previous years, which allowed him to use a larger series of test results for developing his model. Some of the tests included in his analysis were those conducted by Hankins et al. (1994) who performed a total of 74 push-out tests; Lauer et al. (1994) who performed full-scale tests containing standoff screws, Alander et al. (1998) with a total of 106 tests and Webler (2000) who performed 59 tests. The final model that was developed for deck ribs perpendicular to the girder is as follows:

For $0.109 \leq t_{tc} \leq 0.138$, R_n is equal to the minimum of equations 2-4 and 2-5:

$$R_n = 36.71 t_{tc}^{1.61} \left(\frac{H_s}{h_r} \right)^{0.75} (1 - 0.15 w_{r1}^2 + 0.98 w_{r1}) \quad (2-4)$$

$$R_n = \frac{0.18 (Inf'_c) L_{sp} w_{r1}^{0.13}}{N^{0.74}} \leq \frac{0.15 A_{sc} F_{ut}}{t_{tc}^{0.61}} \quad (2-5)$$

Equation 2-4 represents a screw pullout failure, which applies to very thin top chord sections only. The left part of equation 2-5 applies to the condition of concrete rib failure; and finally the right side of equation 2-5 addresses the condition of screw shear failure.

For $0.138 < t_{tc} \leq 0.250$, R_n is equal to:

$$\frac{0.18(Inf'_c)L_{sp}w_{r1}^{0.13}}{N^{0.74}} \leq \frac{0.15A_{sc}F_{ut}}{t_{tc}^{0.61}} \quad (2-5a)$$

where:

L_{sp} = length of shear plane =

$$L_{sp} = 2\sqrt{\left(\frac{w_{r2} - \ell_s}{2}\right)^2 + (H_s - h_r)^2} + \ell_s \quad (2-6)$$

R_n = shear strength per screw, kips

t_{tc} = top chord thickness; in.

H_s = screw height, in.

h_r = rib height; in.

w_{r1} = bottom rib width; in.

f'_c = concrete compressive strength; psi.

w_{r2} = top chord width; in.

N = number of screws in one rib not to exceed 12

A_{sc} = nominal cross-sectional area of screw, in².

F_{ut} = screw tensile strength, ksi.

ℓ_s = vertical distance between screws in a rib; in.

The results from 163 tests were used by Mujagic (2000) to develop his model. The average of the experimental to theoretical strength ratio was 1.009 with a coefficient of variation of 0.107. The range of experimental to theoretical screw strength ratio was from 0.774 to 1.383. This model will be used in this report.

All of the previous research related to push-out tests using standoff screws has used conventional WWF as secondary reinforcement. The research presented in this

report, used specimens reinforced with fibers in addition to specimens reinforced with WWF.

2.2.2 WELDED SHEAR STUDS IN PUSH-OUT TESTS

For the past 30 years, welded shear studs have been the most commonly used type of shear connector in the design of composite members (Rambo-Roddenberry et al. 2001). Since the 1960's, the design of shear studs has been a part of the American Institute of Steel Construction (AISC) specifications. The current AISC specification provisions have been questioned, for which the behavior and strength of welded shear studs are still being studied to provide a thorough understanding of their performance.

In the 1970's, the strength of shear studs in solid slabs was reasonably understood, but the use of cold-formed steel deck in composite construction required additional studies. In 1967, Robinson tested composite beams with steel decking. Further studies were conducted by Fisher (1970) and Grant et al (1977). From these studies, an expression was developed for stud strength that accounted for the presence of steel deck. The nominal stud strength expression incorporated in the current AISC specification is given by:

$$Q_n = 0.5 A_{sc} \sqrt{f'_c E_c} \leq A_{sc} F_u \quad (2-7)$$

Where:

A_{sc} = cross-sectional area of the stud

f'_c = compressive strength of concrete

E_c = modulus of elasticity of concrete

F_u = minimum specified tensile stress of the stud

When the deck rib is perpendicular to the steel member, the nominal strength of the stud shear connector is multiplied by the following reduction factor:

$$\text{SRF} = \frac{0.85}{\sqrt{N_r}} (w_r / h_r) [(H_s / h_r) - 1.0] \leq 1.0 \quad (2-8)$$

Where,

N_r = number of stud connectors on a beam in one rib

w_r = average width of concrete rib
 h_r = nominal rib height
 H_s = length of shear stud after welding

This equation was developed from full-scale beam tests by a back-calculating procedure previously developed by Slutter and Driscoll (1965). Previous research has shown Equation 2-8 to be unconservative for certain configurations (Easterling et al. 1993; Hawkins et al. 1995; Robinson, 1967; Lloyd and Wright, 1990; and Mottram and Johnson, 1990). The stud location within the deck rib has also shown to have an effect in the behavior of the stud. Today most of the steel deck used has a stiffener in the middle of each deck flange, therefore studs cannot be centered. The stud position is described as being “weak” or “strong” and is illustrated in Figure 2.2. The AISC specification, does not account for this, although it does recommend that the studs should be placed in the strong position.

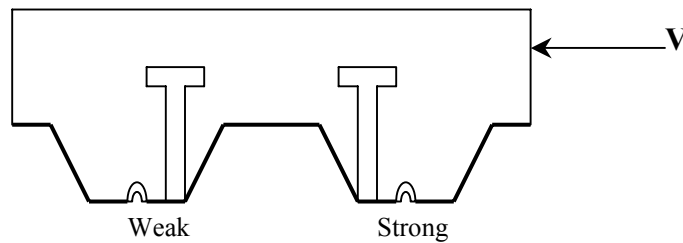

Figure 2.2 Weak and Strong Stud Positions

The position of the stud as well as other parameters that affect the performance of studs were later studied by Rambo-Roddenberry et al. (2001) A new strength prediction model was developed and the results from 202 push-out tests conducted at Virginia Tech and 84 conducted elsewhere were compared to this model. The new strength prediction model developed by Rambo-Roddenberry et al is as follows:

For studs in 1 in. (25 mm), 1 ½ in. (38 mm), 2 in. (51 mm) or 3 in. (76 mm) deck

$$Q_n = R_p R_d A_s F_u \quad (2-9)$$

Where,

$R_p = 0.68$ for $e_{\text{mid-ht.}} \geq 2.2'$ (strong position studs)

$= 0.48$ for $e_{\text{mid-ht.}} < 2.2'$ (weak position studs)

$= 0.52$ for staggered position studs

$R_d = 1.0$ for all strong position studs

$= 0.88$ for 22 ga (0.75 mm) deck (weak studs)

$= 1.0$ for 20 ga (1.0 mm) deck (weak studs)

$= 1.05$ for 18 ga (1.25 mm) deck (weak studs)

$= 1.11$ for 16 ga (1.5 mm) deck (weak studs)

$e_{\text{mid-ht}}$ = distance from the center of a stud to mid-height of the web of the sheeting on the loaded side.

Both the AISC-LRFD and Rambo-Roddenberry's equations will be used in this report.

Chapter 3

COMPOSITE SLABS UNDER DISTRIBUTED LOAD

EXPERIMENTAL PROGRAM

3.1 TEST PARAMETERS

Four three-span composite floor slabs were constructed each consisting of two 10 ft end spans and one 4 ft intermediate span. Tests were performed on both end spans individually for a total of eight tests. All specimens were constructed with 20 ga, a 2 in. deep steel deck with 4.5 in. slab thickness. The slabs consisted of two deck panels for a width of approximately 6 ft. The variable in each casting was the temperature and shrinkage reinforcement, which consisted of 6x6-W2.9xW2.9 WWF for the first slab, 1.5 in. ribbed XOREX steel fibers in quantities of 25 lb/yd³ and 50 lb/yd³ for the second and third slabs respectively and 1.5 lb/yd³ of Microfiber-MD in the fourth slab.

All specimens were constructed similarly. The deck was cut to a total length of 24 ft. Strain gages were attached in accordance with Strain Gage Manual (Measurement Group, 1992). For gage locations see Appendix A-D. The deck sheets were then placed on the beam supports, seams were aligned and the panels were fastened together by button punching. The deck was welded to the supports with 3/4 in. nominal spot welds. Pour stops were screwed to the deck.

For the first casting, the WWF was placed inside the form resting on the top flange of the deck. Concrete was then placed. For the remaining three castings, the specific amounts of fiber were weighed and then added to the concrete truck and mixed for a minimum of five minutes.

The concrete in all castings was normal weight, with a nominal compressive strength of 3,000-psi. Concrete was consolidated with a vibrator. Strains in the steel deck and deflections due to casting were recorded. Concrete cylinders and beams were cast for each mix. Slabs and cylinders were covered with plastic and kept moist for seven days. The pour stop and the plastic cylinder molds were removed on the seventh day. Each composite slab was air cured for a minimum of 28 days.

3.2 INSTRUMENTATION

For the composite slabs tested under distributed load, strain gages were attached to the bottom of the steel deck. Each 10 ft end span had strain gages at six equally spaced locations along the span. Two gages were placed at each of the six locations: one on the top flange and one on the bottom flange for a total of 12 gages per span (see Appendix A-D).

Displacement transducers were placed at both interior and exterior quarter points, at mid-span and under the supporting beams top flange. For casting, two transducers were placed at mid-span and one at each quarter point. For testing, three transducers were placed at each location along the width (see Appendix A-D)

Displacement transducers were used for slip measurements between the steel deck and the concrete. A total of three displacement transducers were placed at each end of the slab.

Uniform load was applied using a restrained airbag. The pressure in the bag was measured with a pressure transducer connected to a pc-based data acquisition system.

Four 9 in. gage lengths were marked on surface of the concrete above the internal supports for measuring crack openings during testing. A Whittemore Gage was used to measure the width of the surface crack at different loads.

3.3 TEST SETUP

The test setup consisted of two W21x68 column frames bolted to the reaction floor. Two W12x26 beams were bolted from one column to the other horizontally. Seven W8x24 beams were attached to the bottom of the W12x26 beams, perpendicular to the composite slab. A rubber press bag was placed on the slab 9 in. away from the interior support of the span being tested, allowing the slab to be loaded along a total of 8.5 ft centered along the total span length. However, all results were converted as if the bag loaded the whole 10 ft span. A 6 ft x 8.5 ft plywood sheet was placed between the airbag and the W8x24 beams (Fig. 3.1). The 9 in. gage lengths for the Whittemore gage were marked on the concrete at four different locations along the interior support (see Appendix A-D). A regulated air source and a pressure transducer were attached to the valves in the

air bag. A hydraulic pressure transducer was also used for verification. All instrumentation was connected to a data acquisition system except for the Whittemore Gage, which was used manually.

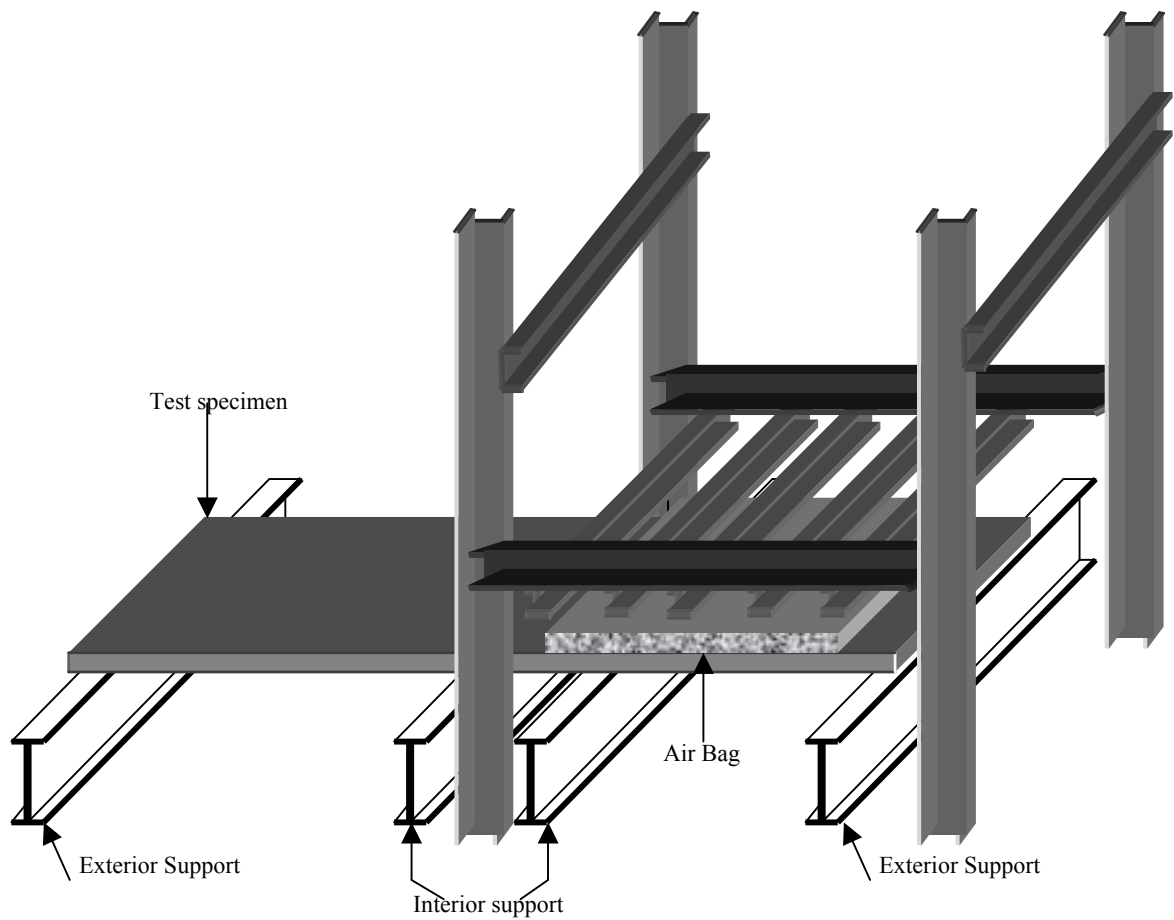

Figure 3.1 Test Setup for Composite Slabs under Distributed Load

3.4 TEST PROCEDURE

The procedure was the same for all tests. The span being tested was first pre-loaded to approximately 30 psf. This allowed the structure to settle, and all of the instrumentation was checked to ensure it was working properly. The slab was then unloaded and all gages were zeroed.

The span was loaded in increments of approximately 30 psf until the first visual crack appeared. The airflow was stopped between increments, data was recorded and crack widths were measured.

After first crack appeared, the load increment was reduced to 10 psf. New cracks were noted and marked.

The slabs were loaded to failure. The bag was then emptied and removed. Cracks on the surface were noted.

3.5 COMPONENT TESTS

Tensile coupons were tested to obtain the actual yield strength of the deck. Cylinder tests were performed in accordance to ASTM C39-96 (Standards, 1998) to obtain the compressive strength of the concrete at different ages. The actual material strengths obtained from these tests were used in calculations. Results are presented in Appendix A-D.

3.6 RESULTS

All slabs exhibited similar behavior during each test under distributed load. The first visible effect of the applied load in most cases was a crack in the concrete surface along the interior support. Subsequently, smaller flexural cracks appeared in the positive moment region. Once the bottom flange of the steel deck yielded, mid-span deflection increased significantly and the steel deck began to debond from the concrete as the load and the steel deck strain increased. The test was terminated after yielding of the steel deck as indicated by a significant decrease in load.

Test results are summarized in Table 3.1. It can be noted that the strengths are higher for the slabs reinforced with 50-lb/yd³ XOREX steel fibers. The strengths of the other two fiber mixes are approximately equal to that of the slab reinforced with WWF.

Table 3.1 Experimental Results

Specimen Number	Test Number	Test Designation	f'_c (psi)	F_y (ksi)	Maximum Load (psf)	Deflection at Max. Load (in.)	End Slip at Max. Load (in.)
1	1	WWF-1	4000	50	367	0.80	0.06
	2	WWF-2	4000	50	337	1.05	0.06
2	3	XOREX25-1	4300	50	305	1.05	0.10
	4	XOREX25-2	4300	50	387	0.76	0.013
3	5	XOREX50-1	5800	50	417	0.48	0
	6	XOREX50-2	5800	50	489	1.50	0.16
4	7	MICROFIBER-MD-1	4250	50	372	4.85	0.95
	8	MICROFIBER-MD-2	4250	50	361	0.64	0.08

The applied load versus mid-span deflection and end slip plots for each specimen are presented in the graphs in the following pages. The theoretical ultimate and first-yield loads are also presented in these graphs. I_{av} represents the stiffness based on the average of the cracked and un-cracked moment of inertia, which is used for determining the theoretical mid-span deflection. The theoretical applied distributed loads that result in the ultimate moment capacity M_n , and first-yield moment M_{et} described in section 3.7.1 are also presented in the graphs.

Applied load versus mid-span deflection for the first and second span tested in each of the four slabs are presented in Figures 3.10 and 3.11. As shown by these graphs, at a typical design load (approximately 70 psf for an office building) the performance of all four slabs was almost the same. The “close-ups” also presented in Figures 3.10 and 3.11, show that mid-span deflections for all four slabs at a typical design load of 70 psf are in the range of 0.015 in. to 0.03 in. These deflections are very small compared to the maximum allowed for serviceability, which is approximate 0.30 in.

3.6.1 WWF-1

WWF-1 was the first end span test for the slab reinforced with WWF. The maximum distributed load applied over a 10 ft span was 367 psf. The failure was sudden at maximum load. Slip was initiated at a load of 336 psf. The slip at maximum load was 0.06 in. and there was a 0.7 in. slip at the termination of the test. The mid-span deflection at maximum load was 0.8 in. and 2.08 in. at the termination of the test. The interior support cracked at a load of 316 psf, followed by flexural cracks in the concrete in the positive moment region at 344 psf. Applied load versus mid-span deflection and end slip are presented in Figure 3.2.

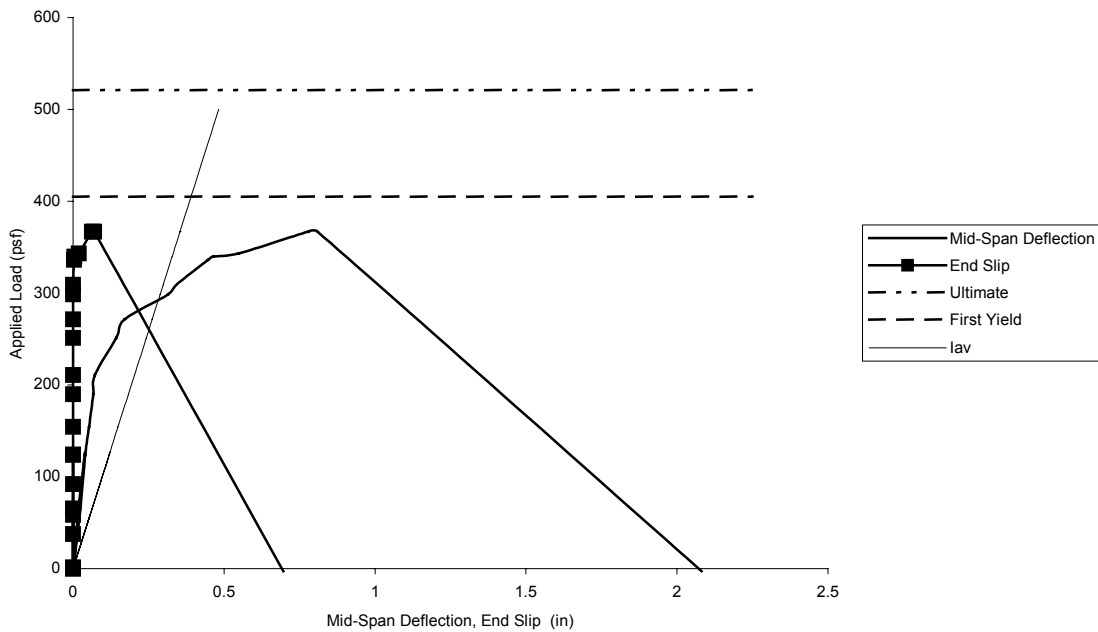

Figure 3.2 WWF-1 Applied Load vs. Mid-span Deflection and End Slip

3.6.2 WWF-2

WWF-2 was the second end span test for the slab reinforced with WWF. The maximum distributed load applied over a 10 ft span was 337 psf. The failure was sudden but less than WWF-1. Slip was initiated at a load of 246 psf. The slip at maximum load was 0.06 in. and there was a 0.8 in. slip at the termination of the test. The mid-span deflection at maximum load was 1.05 in. and 4.28 in. at the termination of the test. The surface of the concrete over the interior support cracked at a load of 323 psf. The first flexural crack in the concrete in the positive moment region appeared at 305 psf. Applied load versus mid-span deflection and end slip are presented in Figure 3.3.

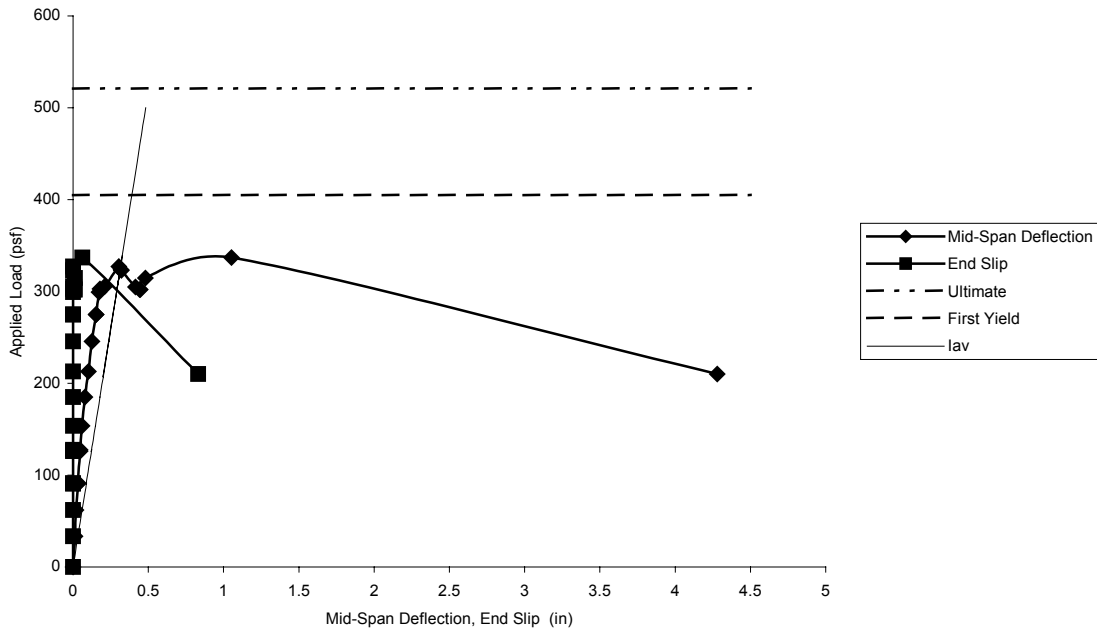

Figure 3.3 WWF-2 Applied Load vs. Mid-span Deflection and End Slip

3.6.3 XOREX25-1

XOREX25-1 was the first end span test for the slab reinforced with 25-lb/yd³ -1½ in. XOREX-Steel fibers. The maximum distributed load applied over a 10 ft span was 305 psf. The failure was sudden at maximum load. Slip was initiated at a load of 297 psf. The slip at maximum load was 0.10 in. and there was a 0.8 in. slip at the termination of the test. The mid-span deflection at maximum load was 1.05 in. and 3.93 in. at the termination of the test. The surface of the concrete over the interior support cracked at a load of 213 psf. The first flexural crack in the concrete in the positive moment region appeared at 244 psf. Applied load versus mid-span deflection and end slip are presented in Figure 3.4.

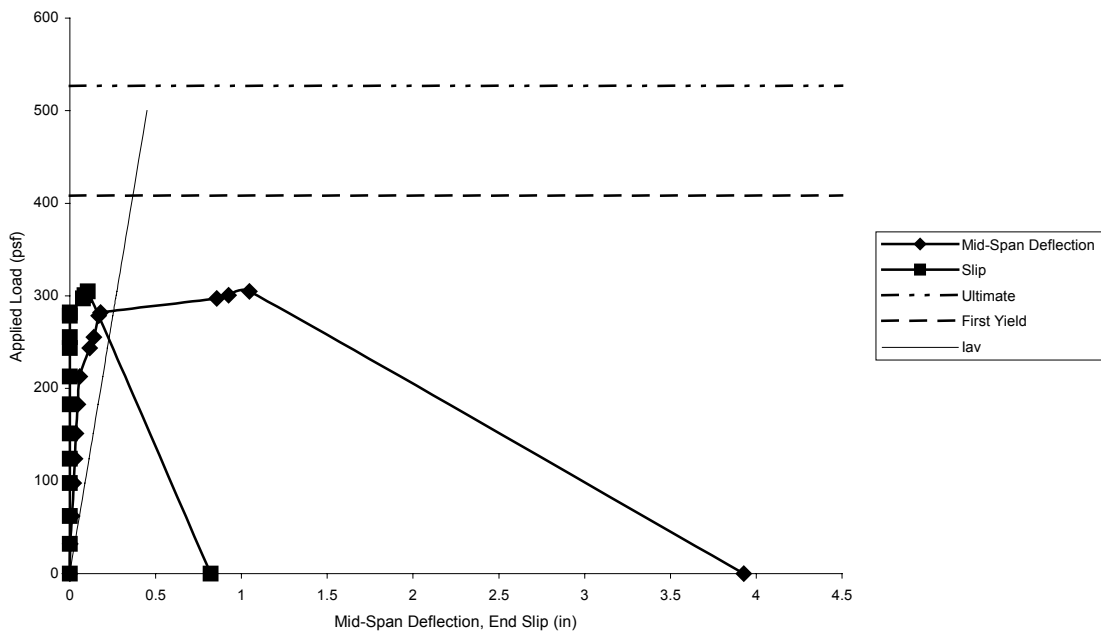

Figure 3.4 XOREX25-1 Applied Load vs. Mid-Span Deflection and End Slip

3.6.4 XOREX25-2

XOREX25-2 was the second end span test for the slab reinforced with 25-lb/yd³ - 1½ in. XOREX-Steel fibers. The maximum distributed load applied over a 10 ft span was 387 psf. Slip was initiated at a load of 384 psf. The slip at maximum load was 0.013 in. and 0.25 in. at the termination of the test. The mid-span deflection at maximum load was 0.76 in. and 1.89 in. at the termination of the test. The first flexural crack in the concrete in the positive moment region appeared at 247 psf. There was no crack on the surface of the concrete over the interior support for this test; instead, the 4 ft. intermediate spans' concrete deflected upward. Applied load versus mid-span deflection and end slip are presented in Figure 3.5.

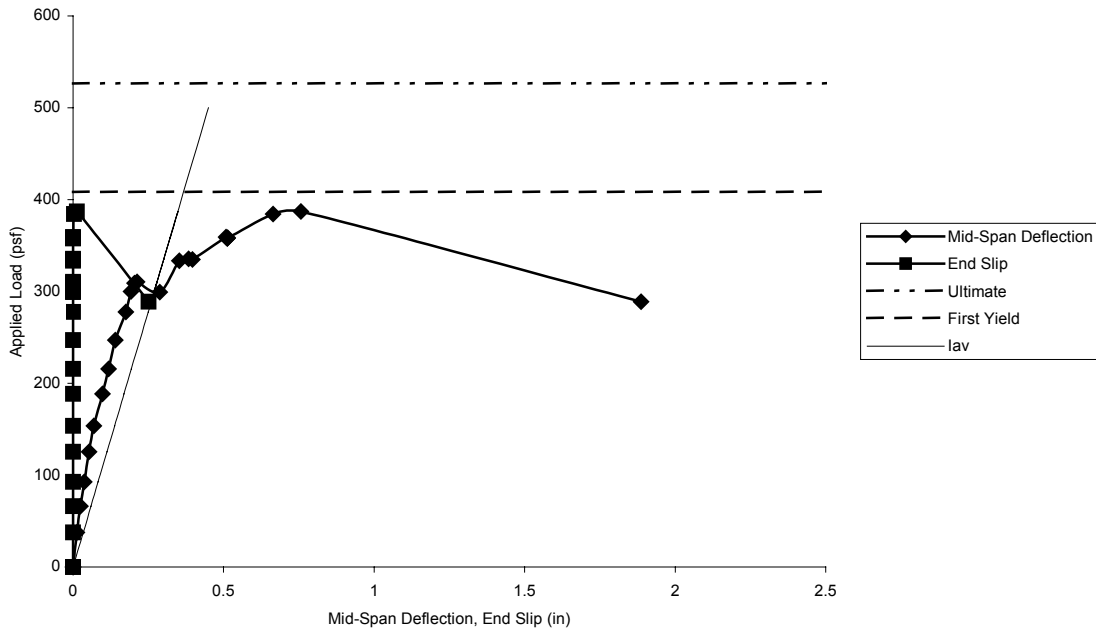

Figure 3.5 XOREX25-2 Applied Load vs. Mid-Span Deflection and End Slip

3.6.5 XOREX50-1

XOREX50-1 was the first end span test for the slab reinforced with 50-lb/yd³ -1½ in. XOREX-Steel fibers. The maximum distributed load applied over a 10 ft span was 417 psf. There was a load drop after maximum load was reached and then the load dropped slowly. Slip initiated after maximum load once the load dropped significantly. There was a 0.5 in. slip at the termination of the test. The mid-span deflection at maximum load was 0.48 in. and 2.31 in. at the termination of the test. The surface of the concrete over the interior support cracked at a load of 314 psf. The first flexural crack in the concrete in the positive moment region appeared at 397 psf. Applied load versus mid-span deflection and end slip are presented in Figure 3.6.

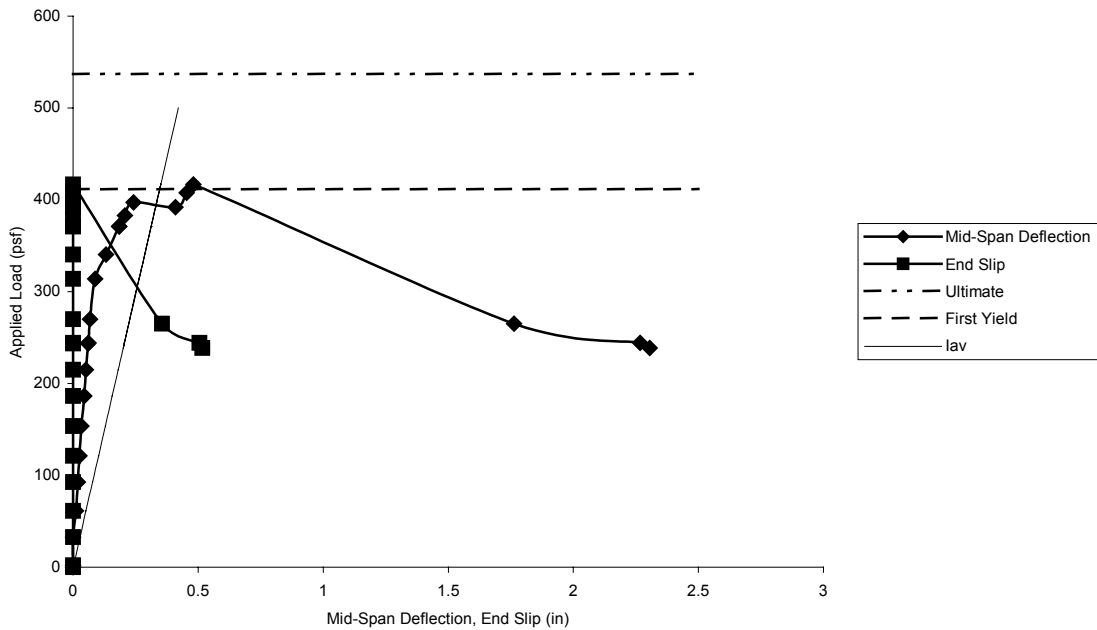

Figure 3.6 XOREX50-1 Applied Load vs. Mid-Span Deflection and End Slip

3.6.6 XOREX50-2

XOREX50-2 was the second end span test for the slab reinforced with 50-lb/yd³ - 1½ in. XOREX-Steel fibers. The maximum distributed load applied over a 10 ft span was 489 psf. Load dropped slowly after maximum load was reached. Slip initiated at a load of 403 psf and was 0.16 in. at maximum load. There was a 0.55 in. slip at the termination of the test. The mid-span deflection at maximum load was 1.5 in. and 3.15 in at the termination of the test. The first flexural crack in the concrete in the positive moment region appeared at 359 psf, followed by the crack on the surface of the concrete over the interior support at 403 psf. Applied load versus mid-span deflection and end slip are presented in Figure 3.7.

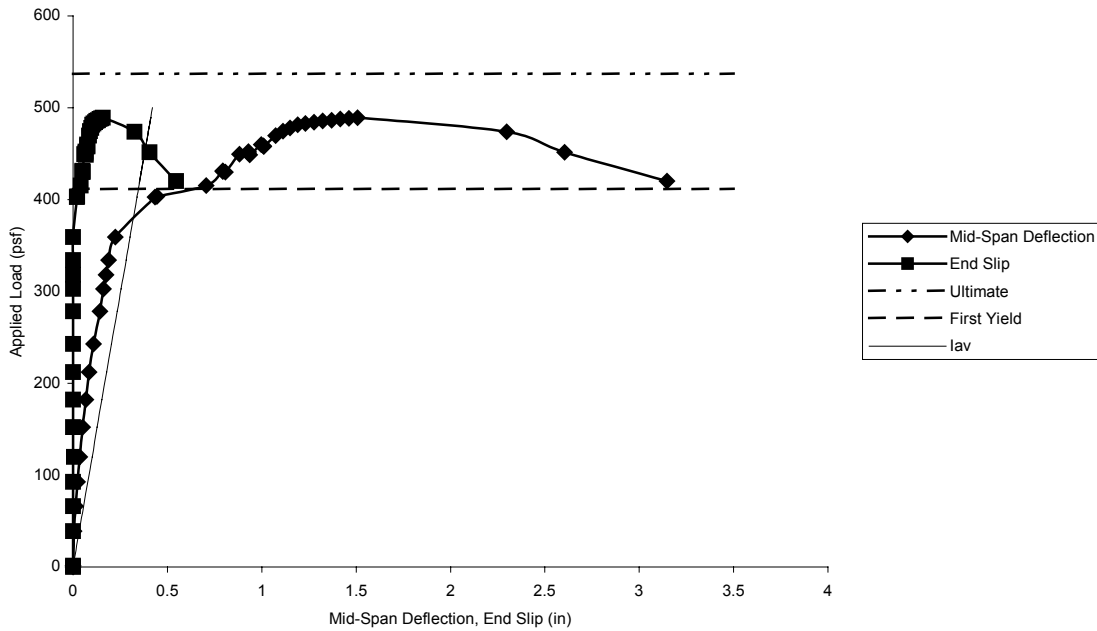

Figure 3.7 XOREX50-2 Applied Load vs. Mid-Span Deflection and End Slip

3.6.7 MICROFIBER MD-1

MICROFIBER MD-1 was the first end span test for the slab reinforced with 1.5-lb/yd³ synthetic micro fiber. The maximum distributed load applied over a 10 ft span was 372 psf. There was sudden load drop from 360 to 326 psf. Later there was a small gradual load drop from 369 to 344 psf, the load was then increased until maximum load was reached and finally the load dropped slowly. Slip initiated after the first load drop to 326 psf. At the maximum load, the slip was measured to be 0.95 in. There was a 1.07 in. slip at the termination of the test. The mid-span deflection at maximum load was 4.85 in. 5.38 in. at the termination of the test. The surface of the concrete over the interior support cracked at a load of 181 psf. The first flexural crack in the concrete in the positive moment region appeared later at 364 psf. Applied load versus mid-span deflection and end slip are presented in Figure 3.8.

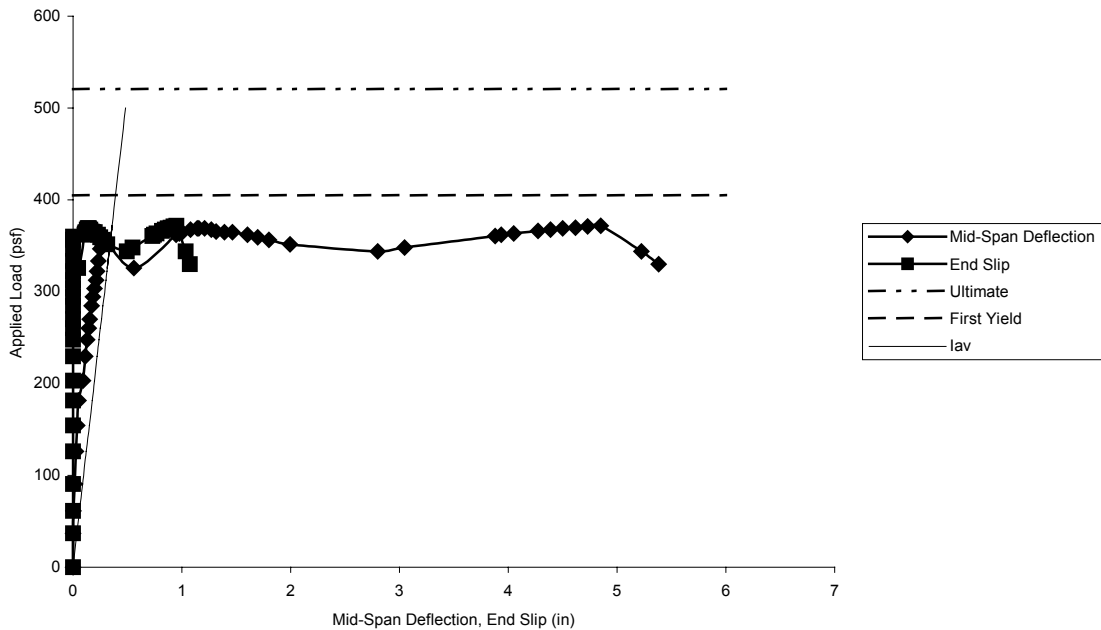

Figure 3.8 MICROFIBER MD-1 Applied Load vs. Mid-Span Deflection and End Slip

3.6.8 MICROFIBER MD-2

MICROFIBER MD-2 was the second end span test for the slab reinforced with 1.5-lb/yd³ synthetic micro fiber. The maximum distributed load applied over a 10 ft span was 361 psf. After reaching peak the load decreased slowly from maximum load to 352 psf and then dropped lower. Slip initiated at 330 psf. At the maximum load, the slip was measured to be 0.08 in. There was a 0.91 in. slip at the termination of the test. The mid-span deflection at maximum load was 0.63 in. 3.36 in. at the termination of the test. The surface of the concrete over the interior support cracked at maximum load once flexural cracks in the concrete in the positive moment region had appeared at 331 psf. Applied load versus mid-span deflection and end slip are presented in Figure 3.9.

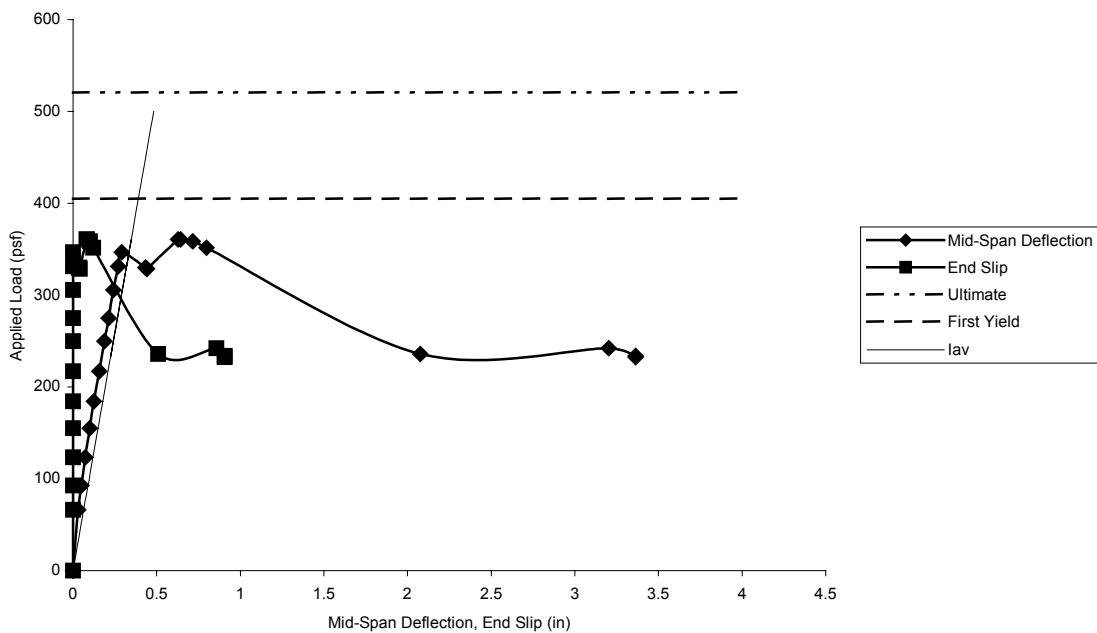

Figure 3.9 MICROFIBER MD-2 Applied Load vs. Mid-Span Deflection and End Slip

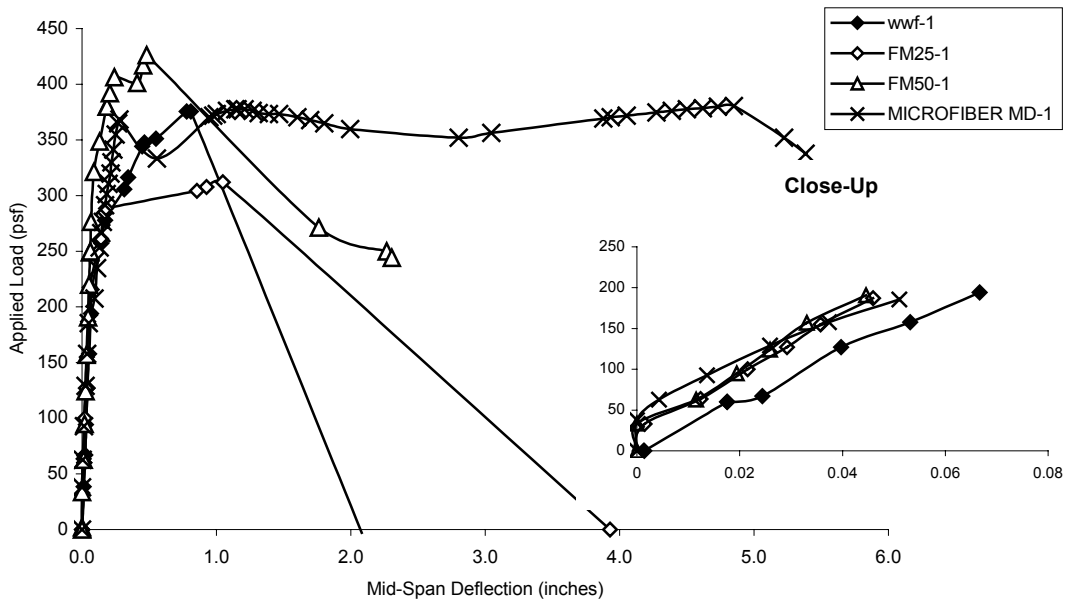

Figure 3.10 Applied Load vs. Mid-Span Deflection for Distributed Load Test on First Span of Slabs

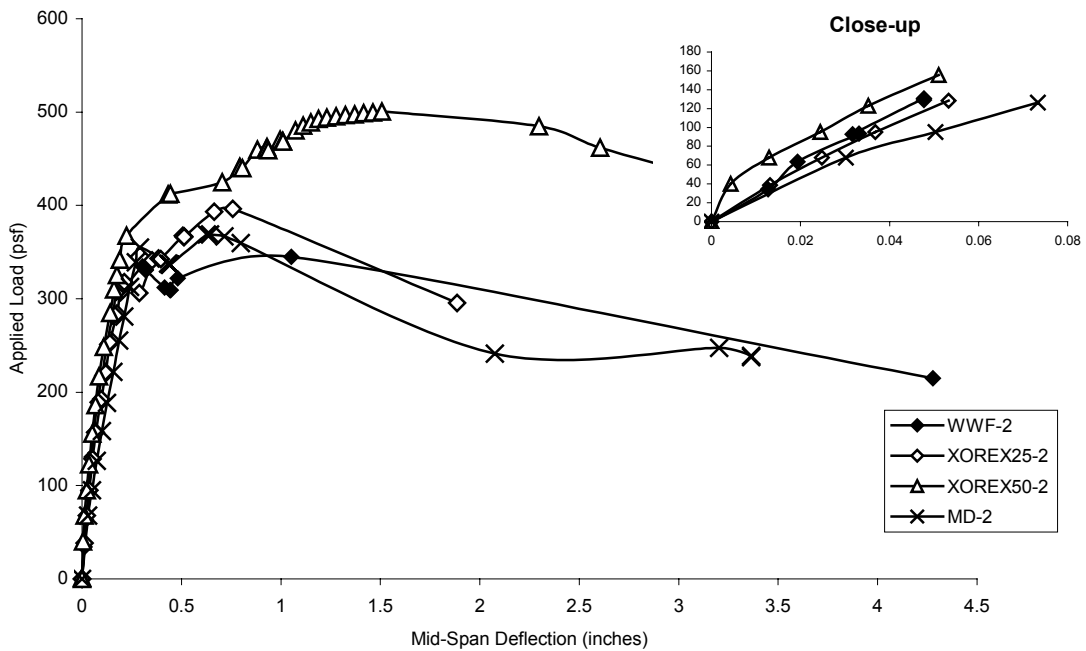

Figure 3.11 Applied Load vs. Mid-Span Deflection for Distributed Load Test on Second Span of Slabs

3.7 EVALUATION OF RESULTS

3.7.1 First Yield Method and ASCE Standard for the Structural Design of Composite Slabs –Appendix D Method

The First Yield Method (FYM) for predicting strength of composite slabs and the Alternate Method presented in Appendix D of the “ASCE Standard for the Structural Design of Composite Slabs” were used in this analysis. The equations are for a flexural-yielding of composite slabs without shear studs.

The FYM considers the slab to be fully composite up to first yield of the bottom flange of the deck. The slab is assumed to crack due to the differential strains, so only the concrete above the neutral axis takes the compressive force. The tensile forces are distributed into three components acting on the top flange, bottom flange and web of the steel deck. The method does not consider the effectiveness of embossments.

The maximum live load deflection for a simple span configuration is given by the equation:

$$\Delta = \frac{5w_L L^4}{384E_c I_{avg}} \leq \frac{L}{360} \quad (3-1)$$

where,

Δ = mid-span deflection

E_c = modulus of elasticity of the concrete

I_{avg} = average of the cracked and un-cracked moments of inertia of the transformed section

n = modular ratio

For composite slabs without shear studs, the limit state is the initiation of yielding at the extreme fiber of the deck bottom flange. The dead load stress due to the fresh concrete was computed using the equation:

$$f_c = \frac{C_n w_D L^2}{S_p} \quad (3-2)$$

Where,

f_c = casting stress in the deck due to fresh concrete

w_D = weight of concrete and deck

L = clear span between supports

S_p = positive deck section modulus

C_n = bending coefficient for positive moment, n number of spans

= 0.087 at casting

= 0.125 at test (unshored simple span)

The calculation for the first-yield moment is based on a cracked section analysis and is given by the equation:

$$M_{et} = T_1 e_1 + T_2 e_2 + T_3 e_3 \quad (3-3)$$

$$e_1 = e_3 - d_d$$

$$e_2 = e_3 - d_d/2$$

$$e_3 = h - y_{cc}/3$$

$$T_1 = f_{yc} (B_t t) [(h - y_{cc} - d_d) / (h - y_{cc})]$$

$$T_2 = f_{yc} (2D_w t) [(h - y_{cc} - d_d) / (h - 0.5y_{cc})]$$

$$T_3 = f_{yc} (B_b t)$$

$$f_{yc} = F_y - f_c$$

$$y_{cc} = d \{ [2\rho n + (\rho n)^2]^{0.5} - \rho n \}$$

where,

M_{et} = first yield moment per unit width

f_{yc} = corrected steel yield stress

f_c = casting stress in deck due to fresh concrete

ρ = Reinforcement ratio, $A_s / (bd)$

n = modular ratio, E_s / E_c

All other variables are illustrated in the following figure:

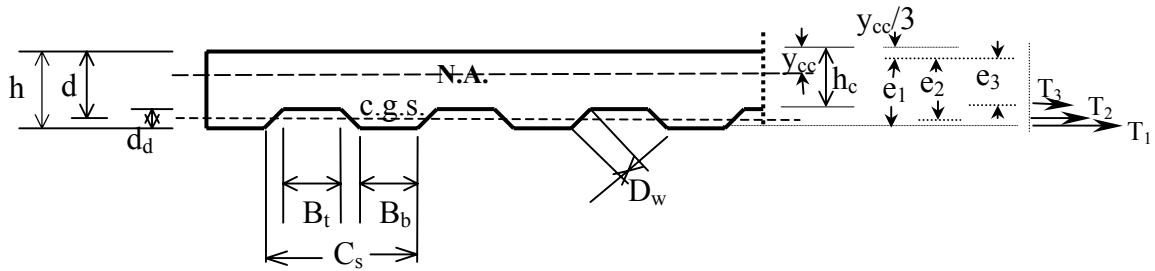

Figure 3.12. Deck Cross Section and Force Locations

The ASCE Appendix D Alternate Method adds an additional factor to the first yield moment, which takes into account other factors such as the number of cell widths in the test slab, the depth of the steel section and the type of embossment. The equation given by the ASCE for the calculated bending moment, M_t , is:

$$M_t = KM_{et}(12/C_s) \quad (3-4)$$

where,

M_{et} = First Yield Moment per unit width

$K = K_3/(K_1 + K_2)$ = bond force transfer property

K_3 is the factor that considers slab width and number of cells in the test slab width (N):

$$K_3 = 0.87 + 0.0688N - 0.00222N^2 \leq 1.4 \quad (3-5)$$

Where,

N = number of cells in test slab width = $12b_d/C_s$, b_b = test slab width, C_s = cell spacing

The factor K_1 is a measure of the influence of the steel section depth on the bond development along the shear span:

$$K_1 = [d_d/7.8]^{0.5} \quad (3-6)$$

Where,

d_d = depth of deck

The K_2 factor indicates the mechanical bond performance along the shear span ℓ'_i and is dependant on the type of embossment. For Types I and III decks, as described in the ASCE manual, the equation is given as:

$$K_2 = [D_w^{0.8}(K_3/SS1)]/[1.0+60(p_h^2 p_s^{1/3})] \quad (3-7)$$

Where,

$$SS1 = (3\ell_{nf}/70)(\ell_{nf} - 14) + 3.6$$

ℓ_{nf} = clear span length, ft.

$$p_s = 12(N_v \ell_e + N_h w)/s \text{ (for Type III)}$$

ℓ_e = length of embossment

N_v = number of vertical elements in embossment pattern lengths

N_h = number of horizontal elements in embossment pattern lengths

w = embossment width, in.

s = length of repeating embossment pattern, in.

p_h = height of embossment, in.

The application of the above equations is limited to the following:

-galvanized steel decks of Types I, II and III embossment patterns

-0.035 in. $\leq p_h \leq$ 0.105 in.

-web angle, θ , between 55° and 90°

-webs with no re-entrant bends in their flat width

- $d_d \leq$ 3 in.

- $C_s \leq$ 12 in.

-2500 psi $\leq f'_c \leq$ 6000 psi

The ultimate moment capacity per unit width of an under-reinforced slab is calculated by the expression:

$$M_n = A_s F_y \left(d - \frac{a}{2} \right) - M_{conc} \quad (3-9)$$

where,

M_n = nominal moment capacity per unit width of slab

- A_s = area of deck per unit width
 F_y = steel yield stress
 d = distance from top of slab to centroid of steel deck
 a = depth of compressive strength block, $A_s F_y / 0.85F'_c b$
 M_{conc} = moment due to concrete weight per unit width of slab

3.7.2 Comparison of Experimental and Theoretical Results

Table 3.2 presents the observed strengths and the predicted strengths calculated with the FYM and the ASCE-Appendix D Alternate Method. The observed maximum applied load is given by W_{test} and refers to the maximum moment produced at mid-span by the applied load assuming simple supports. It is assumed simply supported since there is no reinforcement in the negative moment region even though the deck is still continuous. W_{et} , W_t and W_n refer to the predicted first-yield, predicted flexural strength using the ASCE Appendix D and the maximum capacity respectively. W_n is calculated under the assumption that the slab is under-reinforced and that the entire cross section of the steel deck at maximum moment has yielded. The difference in the theoretical moments for each slab is due to the difference in the concrete compressive strengths.

All calculations are based on the measured material properties (e.g. F_y from coupon tests), for comparisons with the test results.

Table 3.2 Comparison of Experimental and Theoretical Results

Test Number	Test Designation	Wtest (psf)	First Yield W_{et} (psf)	ASCE App.D W_t (psf)	Ult. W_n (psf)	W_{test}/W_{et}	W_{test}/W_t	W_{test}/W_n
1	WWF-1	367	405	405	521	0.91	0.91	0.70
2	WWF-2	337	405	405	521	0.83	0.83	0.65
3	XOREX25-1	305	408	408	527	0.75	0.75	0.58
4	XOREX25-2	387	408	408	527	0.95	0.95	0.73
5	XOREX50-1	417	411	411	537	1.01	1.01	0.78
6	XOREX50-2	489	411	411	537	1.19	1.19	0.91
7	Microfiber MD-1	372	405	405	521	0.92	0.92	0.71
8	Microfiber MD-2	361	405	405	521	0.89	0.89	0.69
mean						0.9313	0.9313	0.7188
σ						0.1303	0.1303	0.0969

Test specimens reinforced with 50 lb/yd³ of XOREX steel fibers had the highest observed test loads W_{test} and were the only ones, which had a W_{test}/W_{et} ratio greater than one. The higher concrete strength in the 50 lb/yd³ mixture may have contributed some to its higher observed test load. XOREX25-2 had the next highest strength. However, this specimen did not crack over the interior support so it will be excluded from comparisons.

The 50-lb/yd³ steel fiber volume showed an average 18.6% increase in strength from the slabs reinforced with WWF (Welded Wire Fabric); the increase in the fiber dosage also increased the strength by approximately 37% if compared to the 25- lb/yd³ steel fiber volume. Specimens reinforced with 1 ½ lb/yd³ of synthetic fibers (MICROFIFER-MD), showed to be approximately equal to specimens with WWF. The strength of the slab reinforced with 25- lb/yd³ XOREX steel fibers was lower than that of the ones with WWF. However, the minimum applied load observed from all specimens was 305 psf, which is considerably higher than a typical design load (about 70 psf for office building).

Strain gages were placed along the span of the steel deck. Plots of applied load versus strain are provided in Appendix A. Load versus deflection at both interior and exterior quarter points are also presented in Appendix A.

The crack widths over the interior support were measured for different load pressures and are presented in Figure 3.13. Again, the XOREX50 specimens showed the smallest crack widths for equivalent applied loads compared to the other three types of specimens. The interior support crack also appeared at higher load pressures for these specimens. Specimens reinforced with WWF and Microfiber-MD showed to be equivalent; while XOREX25 specimens showed slightly larger crack widths.

It is important to note that at a typical design load of 70 psf none of the specimens showed considerable crack widths.

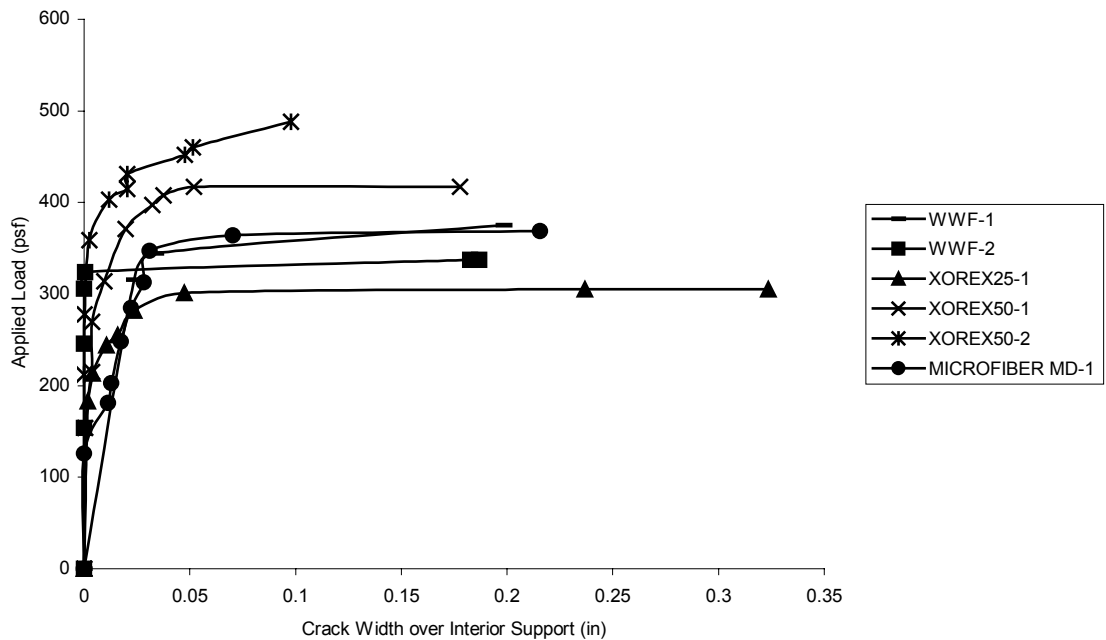

Figure 3.13 Applied Load vs. Crack Width Over Interior Support

3.8 CONCLUSIONS

All slabs failed in a similar manner. Cracks began to form in the concrete once the bottom flange of the steel deck yielded and a crack formed in the concrete in the negative moment region along the interior support.

The slabs reinforced with 50 lb/yd³ of XOREX steel fibers failed at loads approximately 18% higher than slabs reinforced with WWF and showed smaller widening of the support crack. The slabs reinforced with 25 lb/yd³ of XOREX steel fibers and Microfiber-MD failed at similar load magnitudes as the slabs with WWF. Given that all slabs failed in a similar manner and at similar loads, the use of Fiber Reinforced Concrete is an attractive alternative to WWF for temperature and shrinkage reinforcement in composite slabs under distributed load.

Chapter 4

ASTM C1018- Standard Test Method for Flexural Toughness and First-Crack Strength of Fiber-Reinforced Concrete

4.0 GENERAL

This standard ASTM test evaluates the flexural performance of fiber-reinforced concrete by testing a simply supported beam under third-point loading. From this test, toughness parameters can be derived in terms of the area under a load-deflection curve.

The behavior of the fiber-reinforced concrete up to the load at which first crack occurs can be characterized by the first-crack strength. The behavior thereafter, is characterized by the toughness indices, which also reflect the post-crack behavior. The type and quantity of fibers in the concrete matrix influence these parameters (ASTM C1018-97 Standard, 1998).

Figure 4.1 illustrates important characteristics of a load deflection curve, which are discussed below.

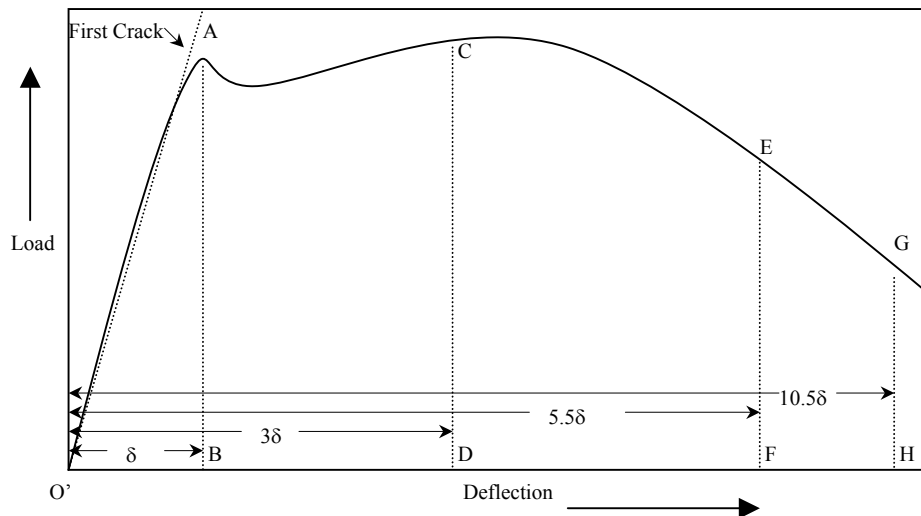

Figure 4.1- Characteristics of a Load-Deflection Curve

The modulus of rupture or first-crack strength is calculated using the equation presented in the ASTM C78 “Standard Test for Flexural Strength of Concrete” as follows:

$$R = PL/bd^2 \quad (4-1)$$

Where:

R = modulus of rupture, psi.

P = maximum applied load indicated by the testing machine, lbf.

b = average width of the specimen, in., at the fracture

d = average depth of the specimen, in., at the fracture

L = span length, in.

The first-crack deflection, δ , is determined by measuring the distance O'B in Figure 4.1.

The toughness indices I_5 , I_{10} and I_{20} are calculated as follows:

$$I_5 = \text{Area } O'ACD / \text{Area } O'AB$$

$$I_{10} = \text{Area } O'AEF / \text{Area } O'AB$$

$$I_{20} = \text{Area } O'AGH / \text{Area } O'AB$$

Where:

I_5 = Toughness Index up to 3.0 times the first-crack deflection

I_{10} = Toughness Index up to 5.5 times the first-crack deflection

I_{20} = Toughness Index up to 10.5 times the first-crack deflection

Areas O'XXX correspond to the areas under the curve in Figure 4.1. Area O'AB is the triangular area under the curve up to first-crack deflection. Area O'ACD is the area under the curve from zero to three times the first-crack deflection. Area O'AEF is the area under the curve from zero to 5.5 times the first-crack deflection. Area O'AGH is the area under the curve from zero to 10.5 times the first-crack deflection.

EXPERIMENTAL PROGRAM

4.1 TEST PARAMETERS

Beam specimens were cast for each of the fiber-reinforced concrete mixtures (25 lb/yd³ and 50 lb/yd³ XOREX steel fibers, 1.5 lb/yd³ Microfiber-MD synthetic fibers). A total of five- 4x4x14 in. beams were tested for each different mixture at 14 days and at 45 days.

All concrete was normal weight and 3000-psi mix. Concrete cylinders were cast to determine compressive strength. Beams were cast in accordance to ASTM-C192 “Standard Method for Making and Curing Concrete Test Specimens in the Laboratory”. The molds were removed after one day and the specimens were placed in a 100% humidity curing room. At least twenty hours prior to the test, the specimens were submerged in water.

4.2 INSTRUMENTATION

LVDT’s were used to measure the deflection at mid-span and on top of the beam directly over the supports (see Figure 4.2). The load was applied by an INSTRON Universal Testing Machine. Measurements were recorded by a data-acquisition system.

4.3 TEST SETUP

As illustrated in Figure 4.2, the test setup consisted of a steel plate at the bottom, two rollers supporting the beam being tested, two rollers at the third points of the beam and a steel plate on top of these rollers. The load was applied at the top steel plate. A thin sheet of metal longer than the width of the beam was attached to the top face of the beam at mid-span. LVDT’s were placed on both sides to measure deflection at mid-span. Two additional LVDT’s were placed at the top face of the beam at the location of the supports.

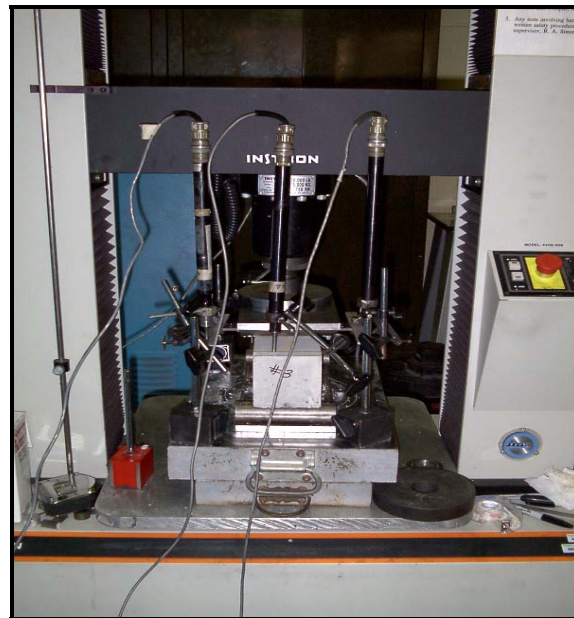
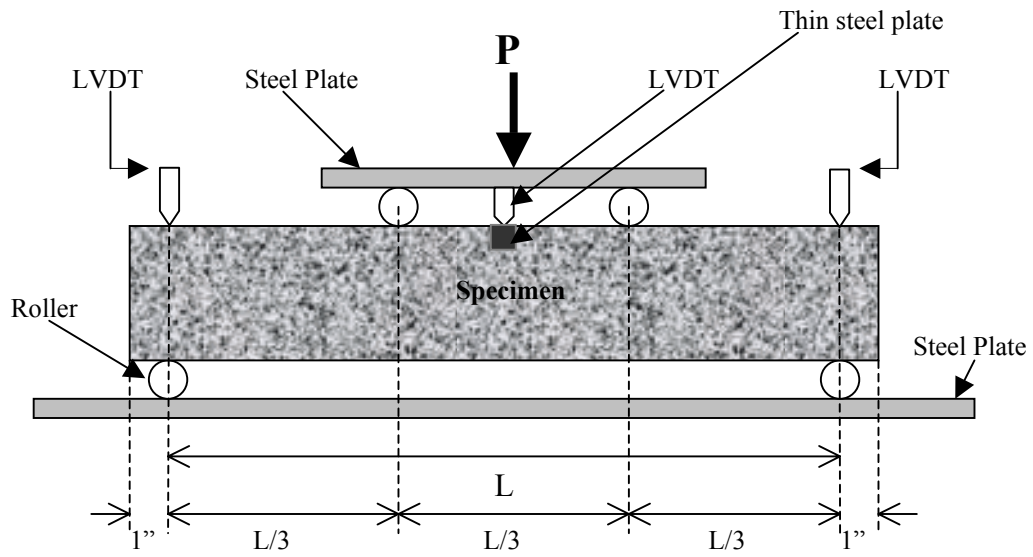

Figure 4.2 Test Setup for ASTM C1018 Test

4.4 TEST PROCEDURE

The test procedure was that specified by the ASTM C1018 Standards. The specimens were measured to determine their actual dimensions. Third points and the location of the supports were marked in order to assure proper placement of the instrumentation. The beam was first placed on top of the support rollers. The thin steel plate was screwed onto the sides of the beam at mid-span. The top rollers were placed at third points and the top steel plate was placed. LVDT's were set at the four measurement locations; the head of the INSTRON machine was lowered so that it was touching but not loading the top steel plate.

The load application was deflection controlled at a rate of 0.004 in./min until first crack, and was increased to 0.008 in./min for the remainder of the test. Measurements were recorded at least five times per second. After the termination of the test, the beam was removed and height and width were again measured. The distance from the edge of the beam to the location of the crack was also measured.

4.5 COMPONENT TESTS

Cylinders were tested in compression in accordance to ASTM C39-96 (1998) standards. The compressive strengths of the concrete mixtures at the test age are presented in Appendix E with their corresponding summary table.

4.6 RESULTS

All beams exhibited similar behavior. The load increased linearly with the deflection until first-crack where there was a large load decrease. In some cases the load increased slightly after the first-crack load and then decreased slowly. In other cases, a large load decrease occurred after first-crack and the load continued to decrease slowly for the remainder of the test.

Most specimens cracked within the mid-third of the span; those that didn't were disregarded in order to comply with ASTM specifications.

4.6.1 Calculations Method

The data recorded by the data acquisition system consisted of deflection values at the support and at mid-span as measured by the corresponding LVDT, and the applied load. Graphs were created for applied load versus deflection for each individual LVDT location. Due to the large number of data points collected and the sensitivity of the LVDT's, some of the original graphs were somewhat erratic and not consistent with each other. For these cases, in order to create one single graph that would represent the behavior, the following procedure was followed:

- I) For the linear portion of the graph, a best-fit line was established by adding a trend line in EXCEL. This was also checked by the least square method which gives the same results.
- II) Using the best-fit line equations, each graph was adjusted so that they would all start at zero load and zero deflection.
- III) The final graph was created by averaging the two mid-span deflection graphs and subtracting the deflection due to local crushing of the concrete at the supports or other support movements.
- IV) Areas under the curve for each load increment were calculated.
- V) Total areas from zero to Δ (first-crack deflection), 3Δ , 5.5Δ and 10Δ were obtained by adding the individual areas corresponding to the specific range of data points.
- VI) The corresponding I_5 , I_{10} and I_{20} values were calculated.

Results for these tests are summarized in Appendix E.

For the beams tested at 14 days, where there were no inconsistencies in the recorded data, the average of the recorded support deflection was subtracted from the average of the recorded mid-span deflection. Load-Deflection graphs were created and the corresponding first-crack deflections and toughness indexes were determined.

4.6.2 Summary of Results

The following table summarizes the results for all fiber-mixes tested at 14 days. Those marked with an asterisk (*) on the age column, correspond to results obtained by Synthetic Industries. These results are used for comparison purposes only. Load-Deflection graphs are presented for each mixture in Figures 4.3-4.5.

Table 4.1 Summary of Results- ASTM C1018

Fiber Mix	Age (days)	Size (in) (wxhxl)	Avg. P_{ult} (k)	R (psi)	Δ_{theor} (in.)	Avg. Δ (in.)	Avg. I_5	Avg. I_{10}	Avg. I_{20}
XOREX 25 lb/yd ³	14*	4x4x14	4.63	N/A	N/A	N/A	N/A	N/A	N/A
XOREX 25 lb/yd ³	14	4x4x14	3.40	657	0.0020	0.0059	4.110	6.077	8.427
XOREX 50 lb/yd ³	14*	4x4x14	5.08	985	0.0022	0.00095	4.9	7.9	12.8
XOREX 50 lb/yd ³	14	4x4x14	3.23	625	0.0019	0.0049	3.878	6.485	10.870
MICROFIBER MD 1.5 lb/yd ³	14*	4x4x14	3.95	769	0.0020	0.001	3.88	5.44	7.32
MICROFIBER MD 1.5 lb/yd ³	14	4x4x14	3.40	671	0.002	0.004	4.303	6.348	7.568

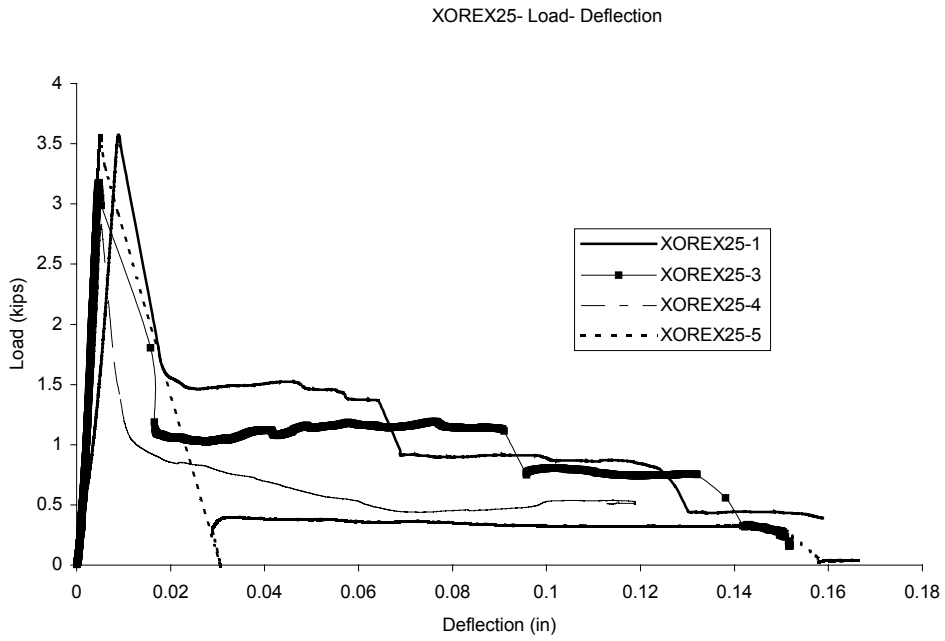

Figure 4.3 – XOREX25- Load-Deflection Curves for ASTM C1018

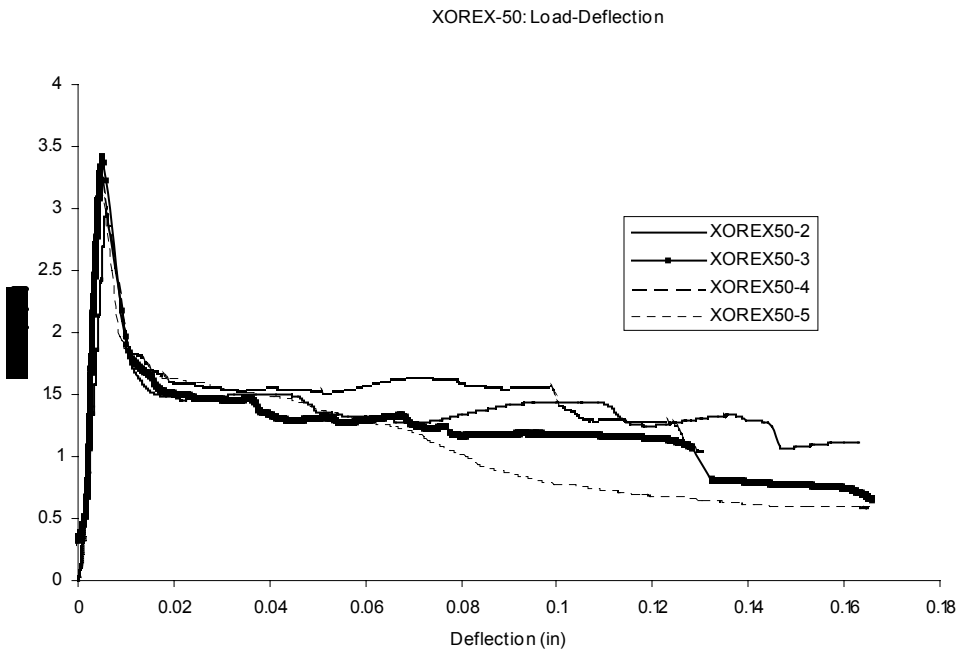

Figure 4.4 – XOREX50- Load-Deflection Curves for ASTM C1018

Microfiber-MD: Load-Deflection

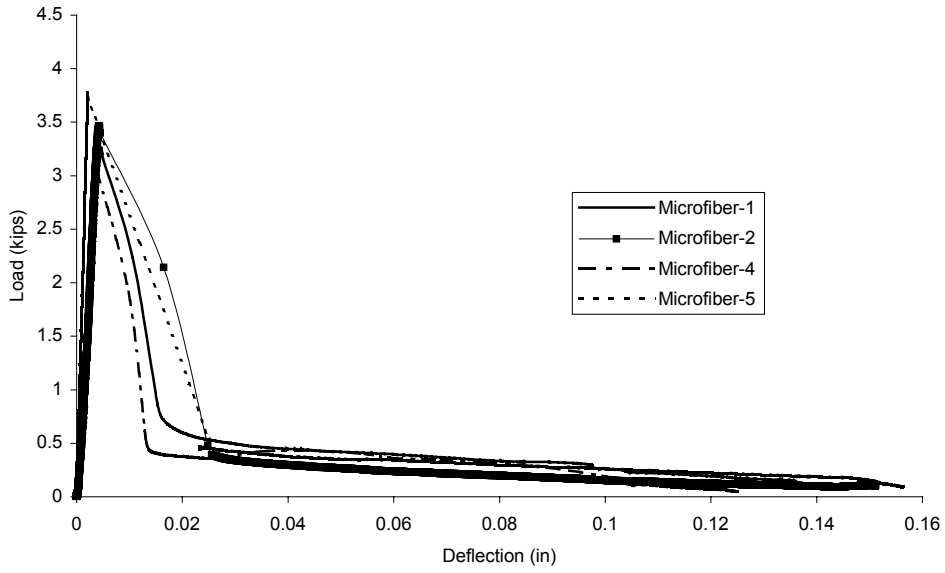

Figure 4.5 – Microfiber MD- Load-Deflection Curves for ASTM C1018

Chapter 5

COMPOSITE SLABS UNDER CONCENTRATED LOADS

EXPERIMENTAL PROGRAM

5.1 TEST PARAMETERS

Four 10 ft simple-span composite floor slabs were constructed. All specimens were constructed with 20 ga steel deck with 2 in. rib height and 5.5 in. total slab thickness. Three deck panels were used for a total of 9 ft width. The first slab was reinforced with 6x6-W2.9xW2.9 WWF. The second and third slabs were reinforced with 1.5 in. ribbed XOREX steel fibers in the quantities of 25 lb/yd³ and 50 lb/yd³ respectively. The fourth slab was reinforced with 1.5 lb/yd³ of Microfiber-MD.

All specimens were constructed similarly. The deck was cut to a total length of 10 ft. Strain gages were attached. For strain locations see Figure 5.1. The deck was welded to the supports with 3/4 in. spot weld, and pour stops were fastened with screws.

For the first casting, the WWF was placed inside the form, resting on the top flange of the deck. Concrete was then placed. For the remaining three castings, the specific amounts of fiber were weighed and blended with the concrete for a minimum of five minutes.

The concrete in all castings was normal weight, with a nominal compressive strength of 3,000-psi and screed vibrated. Strains in the steel deck and deflections due to casting were recorded. Concrete cylinders were cast for each mix. Slabs and cylinders were covered with plastic and moist cured for seven days. The pour stop and plastic cylinder molds were removed after seven days. Each composite slab was cured for a minimum of 28 days.

5.2 INSTRUMENTATION

A total of eighteen strain gages were attached to the bottom part of the steel deck of each slab. Six were located at the bottom flanges along each quarter point and along mid-span.

Transducers (Wire pots) were used to measure deflection. A total of six transducers were placed equally spaced along each quarter point and at mid-span.

Displacement transducers were used for end slip measurements between the steel deck and the concrete. Two were placed at each end of the slab.

Concentrated loads were applied using a hydraulic jack.

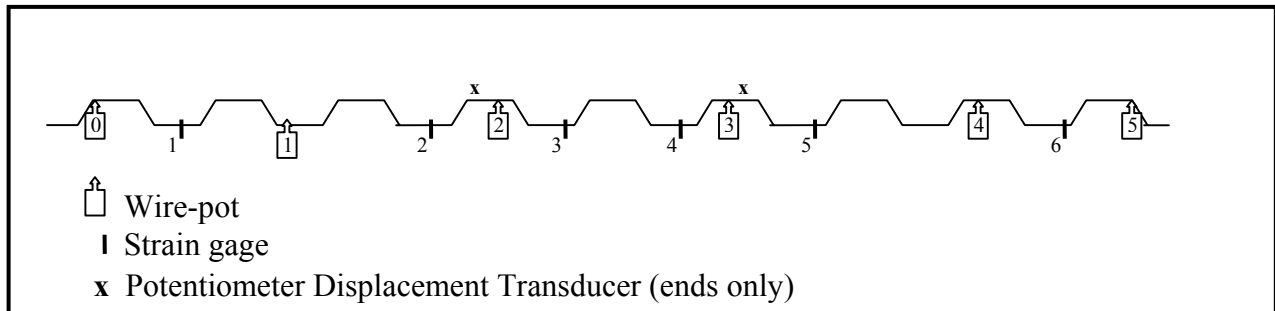

**Figure 5.1 Strain Gage and Displacement Transducers Locations
(Typical at quarter points and at mid-span)**

5.3 TEST SETUP

The test setup consisted of two W21x68 column frames bolted to the reaction floor. Two W12x26 beams were bolted from one column to the other horizontally. One beam was attached to the bottom of the W12x26 beams, perpendicular to the composite slab. This beam was moved to different locations along the span (Fig. 5.2-A). A 1''x12''x12'' steel plate was placed at the different concentrated load locations. A 1''x12''x12'' piece of wood was placed between the slab and the steel plate. A hydraulic jack and load cell were placed between the beam and the steel plate (Fig. 5.2-B). An 8 in. deep, 4 ft long beam was used for the line loads. A rubber pad was placed between the slab and the beam (Fig. 5.2-C).

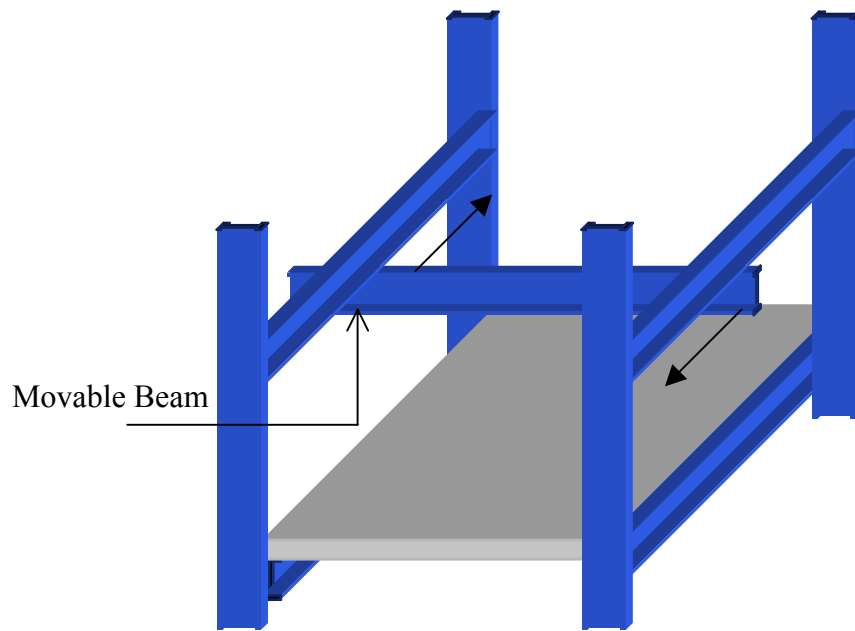

Figure 5.2 A- Test Setup for Concentrated Load Tests

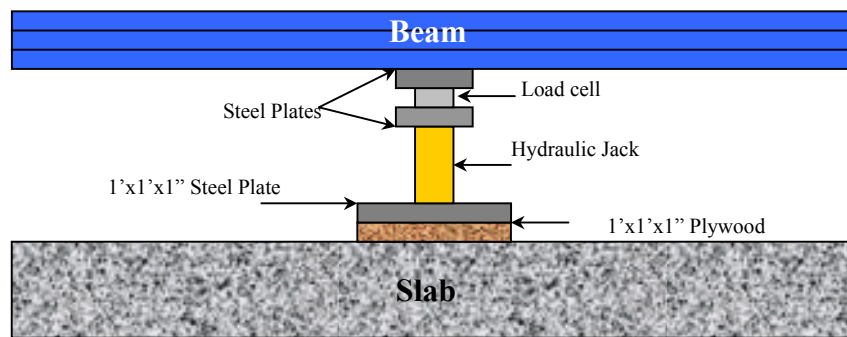

Figure 5.2 B- Setup Detail for Concentrated Load Test (side view)

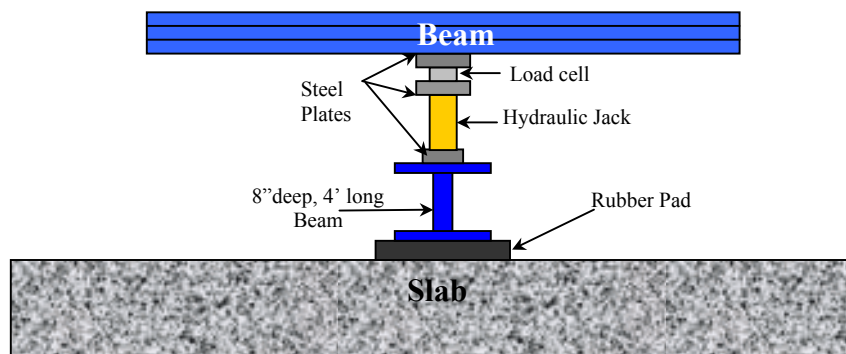
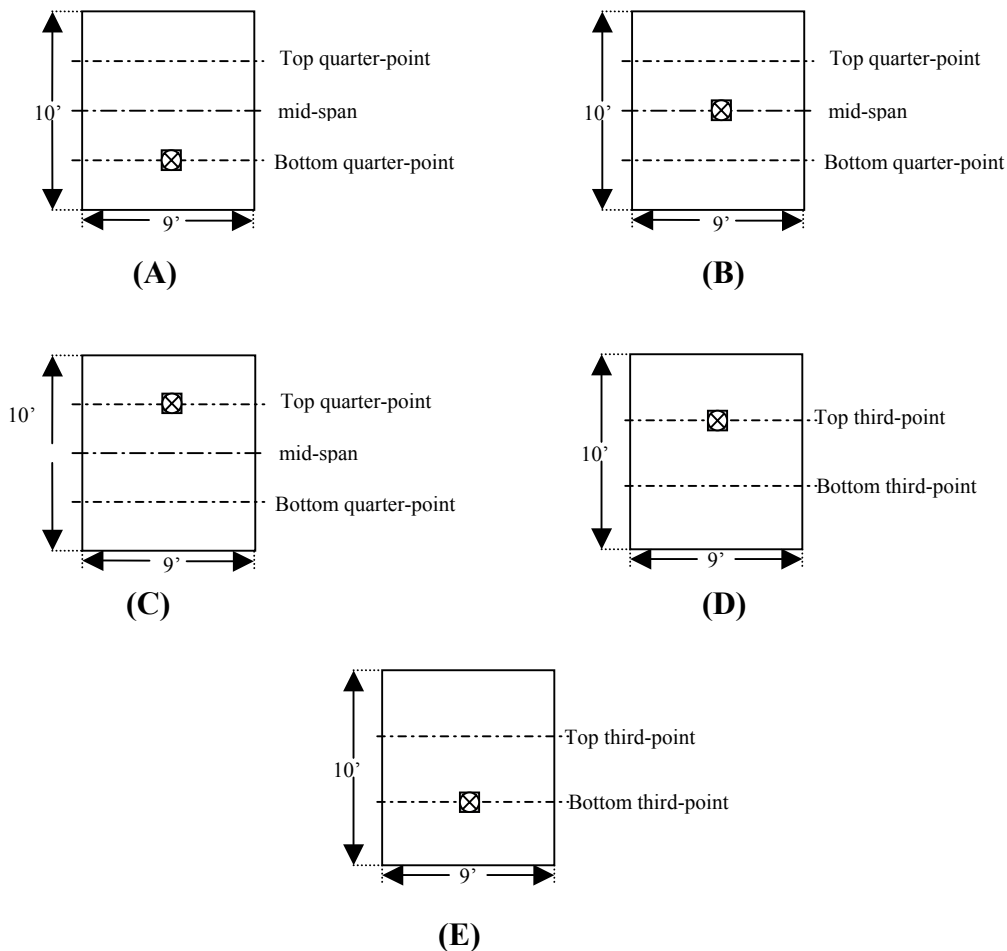

Figure 5.2 C- Setup Detail for Line Load Tests (side view)

5.4 TEST PROCEDURE

A total of eleven tests were performed on the first three slabs, eight were performed on the slab reinforced with Microfiber-MD. The test procedure and order was the same for all slabs. First, the slab was loaded to 5 kips and then unloaded. This was repeated for a second time, allowing the slab to settle and to make sure that all of the instrumentation was working properly. For the concentrated loads, the slab was loaded in increments of 500 lbs. For the line loads, the slabs were loaded in increments of 1000 lbs. Recordings were taken at each load increment and cracks were marked. The slab was then unloaded and the setup was moved to the next load point. The different load locations are presented in Figures 5.3 A-K.



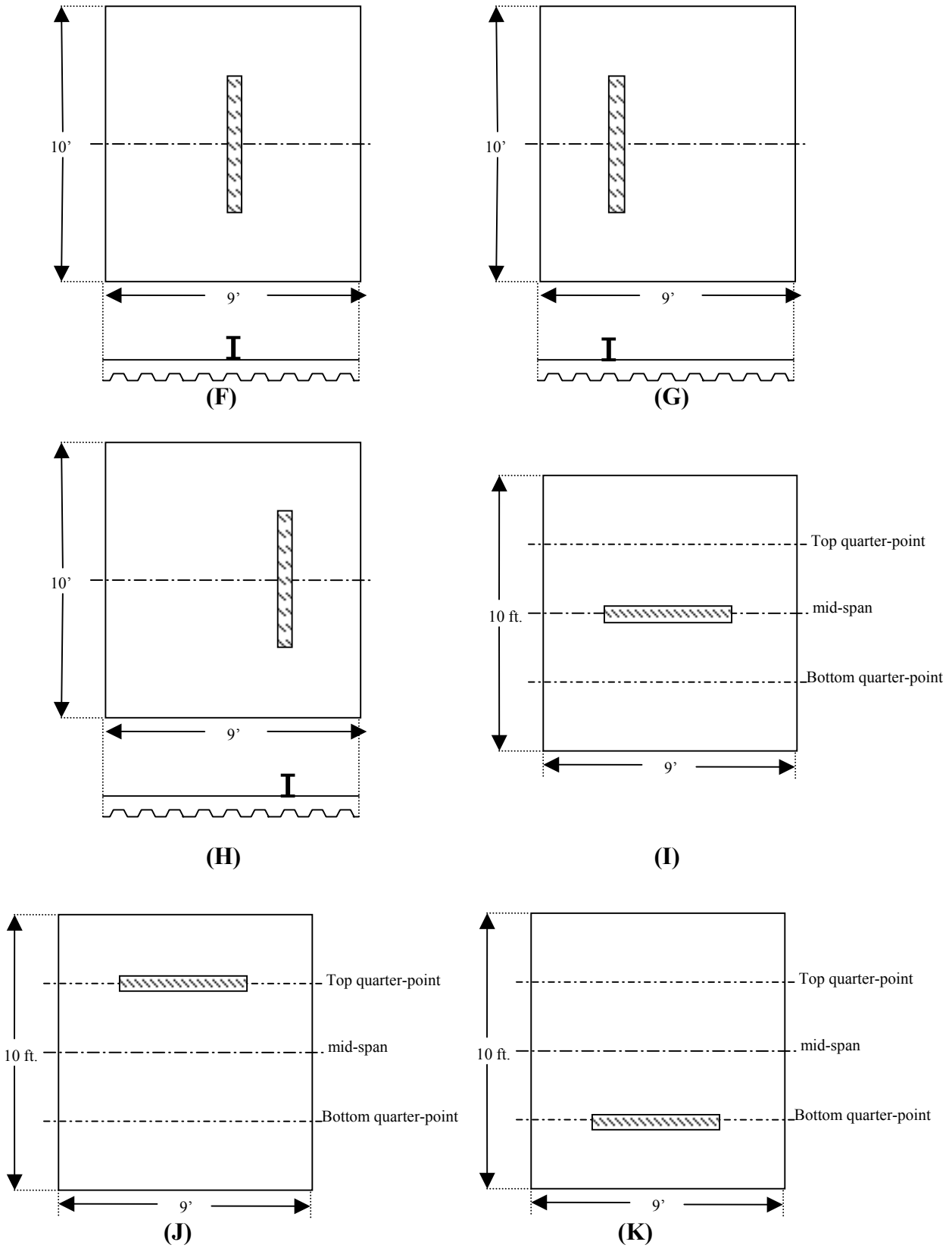

Figure 5.3 (A)-(K) Concentrated and Line Load Locations

5.5 COMPONENT TESTS

Tensile coupons were tested to obtain the actual yield strength and tensile strength of the deck. Cylinder tests were performed in accordance to ASTM C39 standard to obtain the compressive strength of the concrete at different ages. Results are presented in Appendix F.

5.6 RESULTS

The complete set of results on all eleven tests performed on the slabs are presented in Appendix F. The results presented in this chapter will focus on the test where a concentrated load was applied at mid-span.

All slabs exhibited similar behavior. There were no visible cracks while the slab was loaded up to 10-kips. Both slabs reinforced with XOREX steel fibers were loaded up to 10 kips only, so that no major damage had occurred prior to the remaining tests. The slabs reinforced with WWF and Microfiber-MD cracked at load magnitudes of 15 and 14-kips respectively. The tests were stopped when these cracks occurred. Test results at a load magnitude of 10-kips are summarized in Table 5.1; none of the slabs had slipped at this load.

Table 5.1 Experimental Results at 10-kip Concentrated Load at Mid-Span

Test Designation	f'_c (psi)	F_y (ksi)	Deflection Along Center Strip (in)			Bottom Flange Strain Along Center Strip ($\mu\epsilon$)		
			Mid-Span	Quarter Point-1	Quarter Point-2	Mid-Span	Quarter Point-1	Quarter Point-2
WWF	3400	50	0.068	0.045	0.046	266	70	108
XOREX-25	4000	50	0.058	0.037	0.041	129	71	115
XOREX-50	4200	50	0.053	0.032	0.043	127	79	62
Microfiber-MD	3800	50	0.063	0.051	0.046	251	77	110

Results show similar deflections in all slabs. Slabs reinforced with XOREX steel fibers exhibited slightly smaller deflections than the slabs reinforced with WWF and Microfiber-MD, which consequently results in smaller strains. The difference in quarter-

point strains can be a consequence of having performed one quarter-point test (Fig. 5.3-A) prior to the mid-span test (Fig. 5.3-B).

5.6.1 WWF

The slab reinforced with WWF was the first slab to be tested. All eleven load locations presented in Figures 5.3 A-K were performed in that order. This slab was loaded to a maximum of 15 kips at every load location. The first crack occurred at mid-span during the second test (Fig. 5.3-B) at a load magnitude of 15 kips. New cracks were formed with the remaining tests and are illustrated in Figure 5.4. The numbers correspond to the test number or load location, for example Figure 5.3 A corresponds to test 1 and Figure 5.3 K corresponds to test 11.

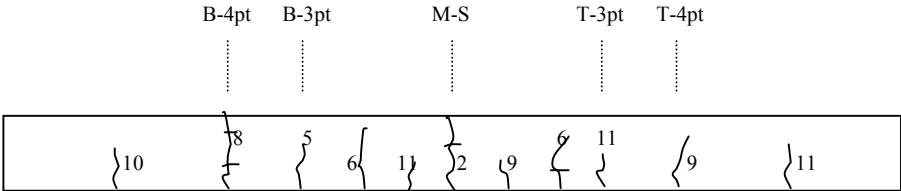

Figure 5.4- Cracks formed on both sides of the slab with WWF

The results from the second test (Concentrated Load at Mid-Span) are presented in the following Figures. Figure 5.5 illustrates how the slab deflected when a 10-kip load was applied. The maximum deflection occurred on the middle strip at mid-span (location of the concentrated load), and had a magnitude of 0.068 in. The strains on the bottom flange of the steel deck along the span are presented in Figure 5.6. The numbers 1 through 6 correspond to the strain gage locations illustrated in Figure 5.1.

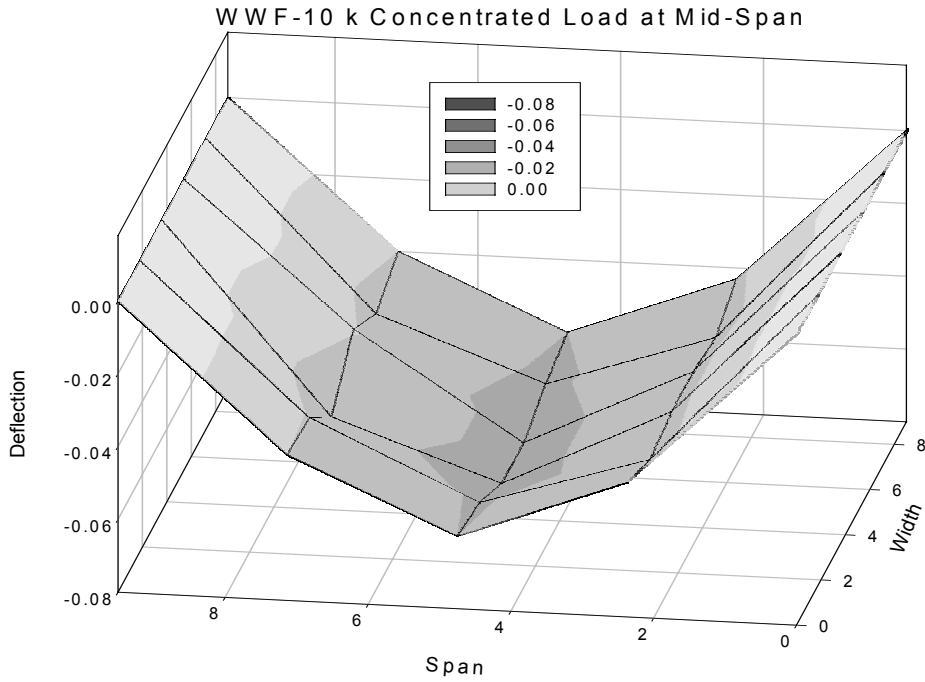

Figure 5.5- WWF Slab Deflection with 10-kip Concentrated Load at Mid-Span

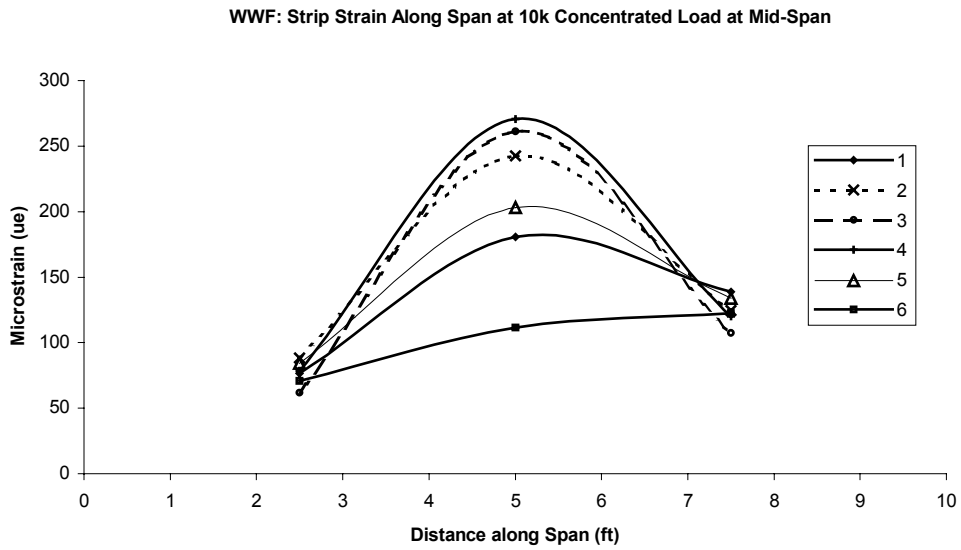

Figure 5.6- WWF Strain Along Span with 10-kip Concentrated Load at Mid-Span

5.6.2 XOREX-25

All eleven tests presented in figures 5.3A-K were performed on this slab. At mid-span locations (Fig. 5.3B,F) the slab was loaded to a maximum of 10 kips and was loaded till failure with the transverse line load at mid-span (Fig. 5.3 I). The first visible crack occurred during this test at mid-span at a load magnitude of 13.75 kips; this was also the failure load. At all other locations, the maximum applied load was 13-kips.

Test results for concentrated load at mid-span (Fig. 5.3B) at a load magnitude of 10-kips are illustrated in the following figures. Figure 5.7 illustrates how the slab deflected with the 10-kip load. The maximum deflection occurred on the middle strip at mid-span (location of the concentrated load), and had a magnitude of 0.058 in. The strains on the bottom flange of the steel deck along the span are presented in Figure 5.8. The numbers 1 through 6 correspond to the strain gage locations illustrated in Figure 5.1.

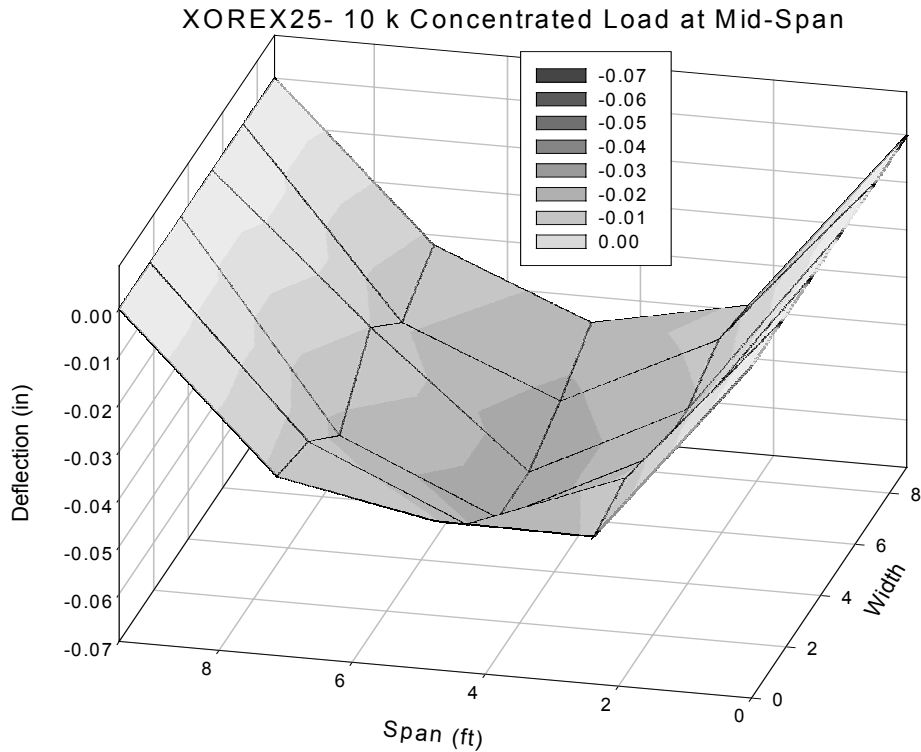

Figure 5.7- XOREX25-Slab Deflection with 10-kip Concentrated Load at Mid-Span

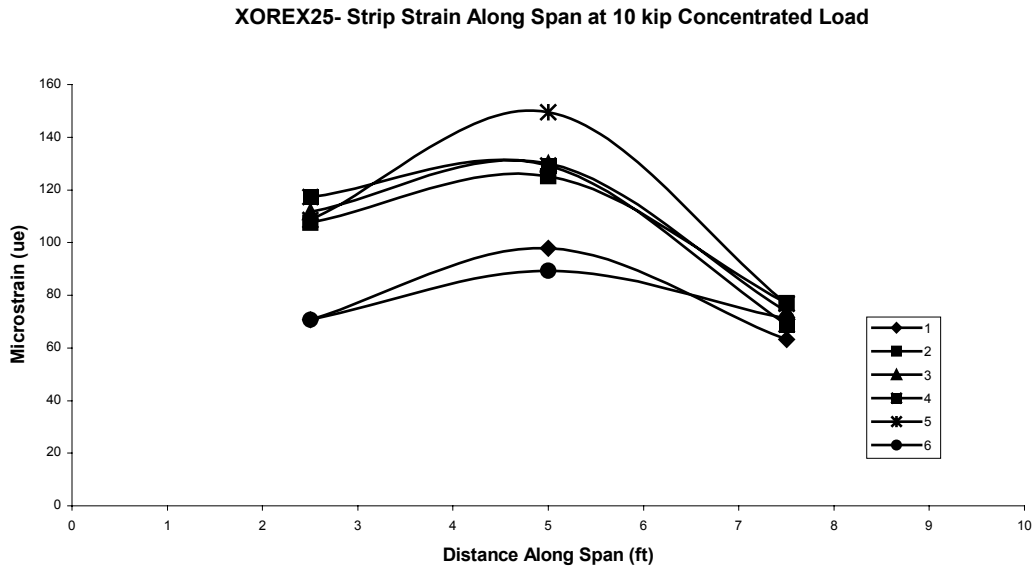

Figure 5.8 XOREX25- Strain Along Span with 10k Concentrated Load at Mid-Span

5.6.3 XOREX-50

All eleven tests presented in figures 5.3A-K were performed on this slab. At mid-span locations (Fig. 5.3B,F) the slab was loaded to a maximum of 10 kips and was loaded till failure with the transverse line load at mid-span (Fig. 5.3-I). The first visible crack occurred during this test at mid-span at a load magnitude of 13.4 kips; the failure load was 13.7 kips. At all other locations, the maximum applied load was 13-kips.

Test results for concentrated load at mid-span (Fig. 5.3B) at a load magnitude of 10-kips are illustrated in the following figures. Figure 5.9 illustrates how the slab deflected with the 10-kip load. The maximum deflection occurred on the middle strip at mid-span (location of the concentrated load), and had a magnitude of 0.053 in. The strains on the bottom flange of the steel deck along the span are presented in Figure 5.10. The numbers 1 through 6 correspond to the strain gage locations illustrated in Figure 5.1.

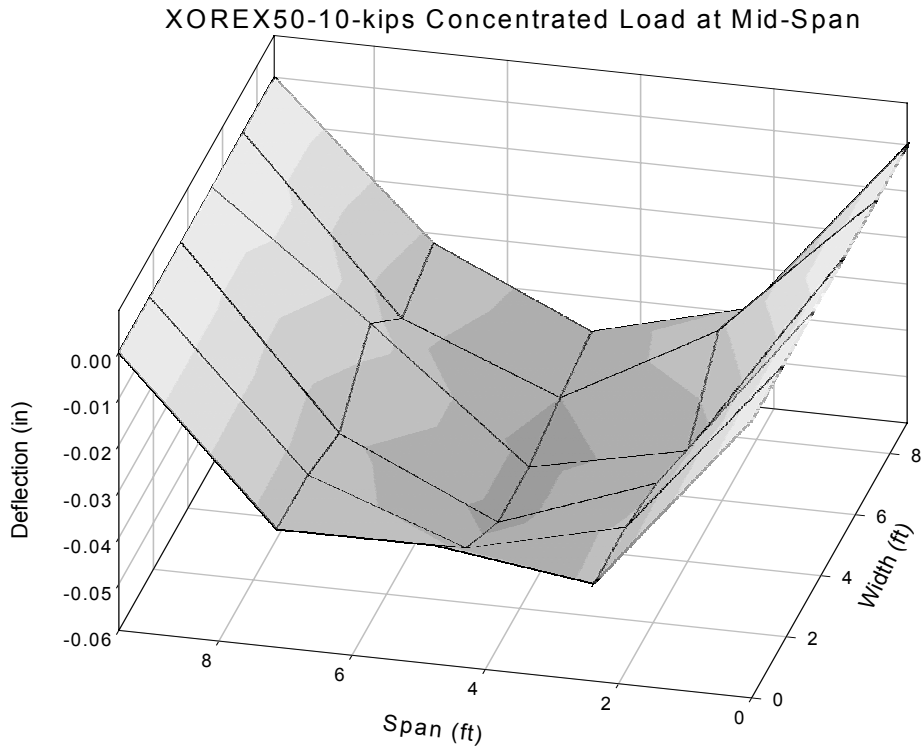

Figure 5.9- XOREX50 Slab Deflection with 10-kip Concentrated Load at Mid-Span

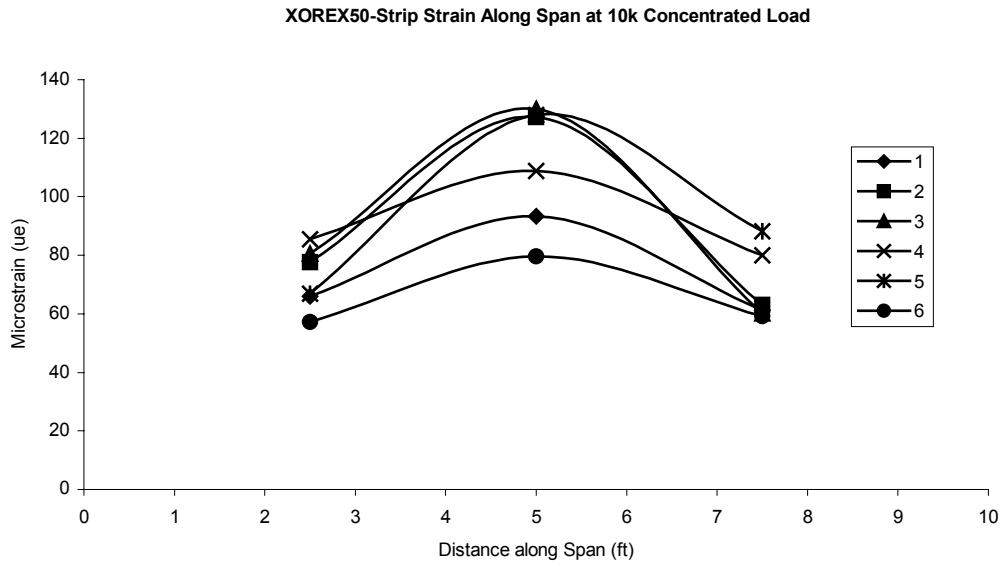

Figure 5.10 XOREX50 Strain Along Span with 10k Concentrated Load at Mid-Span

5.6.4 Microfiber-MD

The first nine of the eleven tests presented in figures 5.3A-K were performed on this slab. At location B (Fig. 5.3B) the slab was loaded to a maximum of 14 kips where it cracked. New cracks were formed during the other tests and are illustrated in Figure 5.11. The numbers 2,4 and 5 correspond to the test number, for example number 2 corresponds to the test illustrated in Figure 5.3B. The crack formed at the quarter point extended to the surface of the slab.

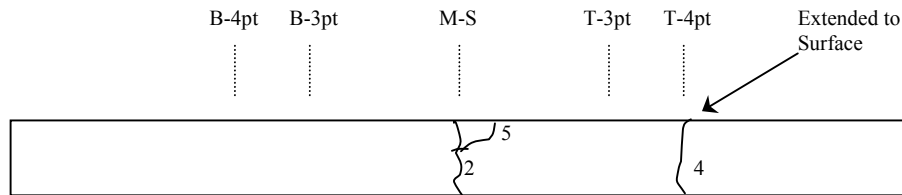

Figure 5.11-Cracks formed on both sides of the slab with Microfiber-MD

Test results for the concentrated load at mid-span (Fig. 5.3B) at a load magnitude of 10-kips are illustrated in the following figures. Figure 5.12 illustrates how the slab deflected with the 10-kip load. The maximum deflection occurred on the middle strip at mid-span (location of the concentrated load), and had a magnitude of 0.063 in. The strains on the bottom flange of the steel deck along the span are presented in Figure 5.13. The numbers 1 through 6 correspond to the strain gage locations illustrated in Figure 5.1.

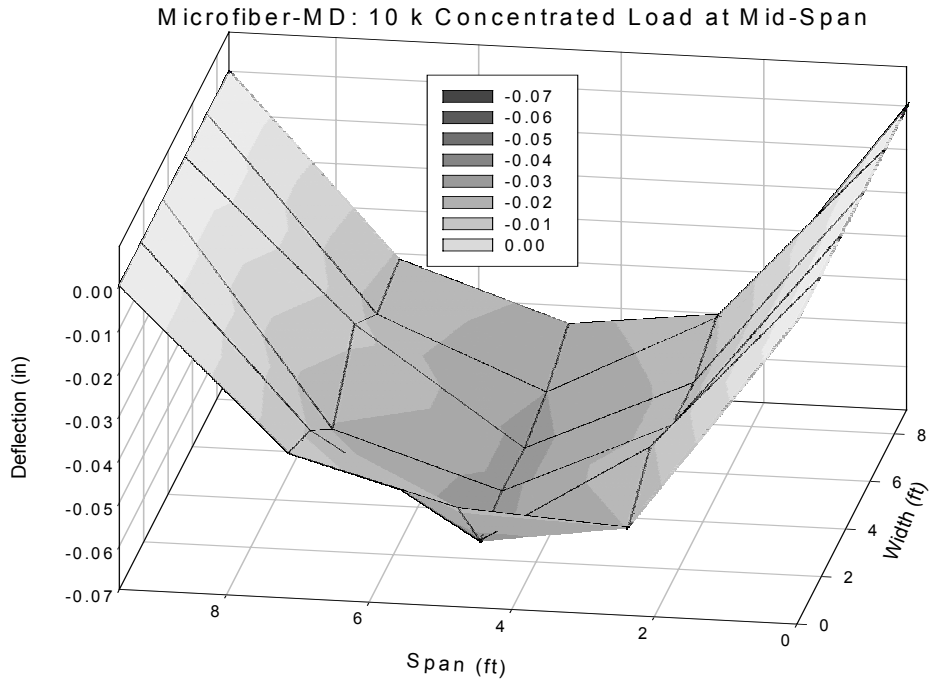

Fig. 5.12 Microfiber-MD Slab Deflection with 10k Concentrated Load at Mid-Span

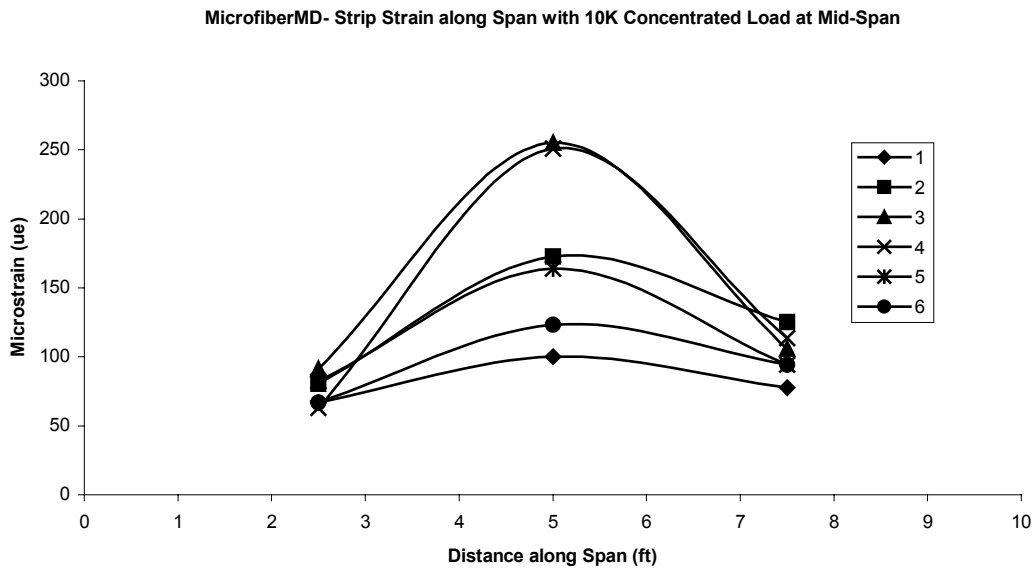

Figure 5.13- Microfiber-MD Strain Along Span with 10k Concentrated Load at Mid-Span

5.7 EVALUATION OF RESULTS

Table 5.2 shows the observed maximum applied moments and the predicted strengths calculated using the ASCE Method (Standard, 1992) and Luttrell’s method (1995) described in chapter 2.

Table 5.2 Theoretical Moments Versus Observed Moments for Slabs under Concentrated Loads

Slab	ASCE M_{th} (ft.lbs)	Luttrell (1995) M_{th} (ft.lbs)	M_{test} (ft.lbs)	$M_{test}/M_{th-ASCE}$	$M_{test}/M_{th-Luttrell}$
WWF	8,470	34,716	37,500	4.43	1.08
XOREX-25	8,530	34,962	34,375	4.03	0.98
XOREX-50	8,551	35,049	34,250	4.00	0.98
Microfiber-MD	8,511	34,886	35,000	4.11	1.00

The results presented in Table 5.2 show that the method proposed by Luttrell (1995) for “Transverse Distribution of Non-Uniform Loads on Composite Slabs” is an accurate prediction of the moment capacity not only for slabs reinforced with WWF but with slabs reinforced with the fibers used in this study as well. This is shown by the ratio M_{test}/M_{th} , which for all cases is very close to 1.0. These results also show the inadequacy of the ASCE Method in cases of non-distributed loads in composite slabs. Sample Calculations for these methods are presented in Appendix I. The effective width of slab according to the ASCE method is calculated using the equation:

$$B_e = b_2 + t_c \quad (5-1)$$

Where,

b_2 = width of the load area in the transverse direction

t_c = cover depth of concrete

Using Equation 5-1, the width of slab affected by the concentrated load is 1.3 ft, while Luttrell’s method (1995) estimates an affected width of 5.3 ft (see Appendix I). The results demonstrate that Equation 5-1 is inaccurate for predicting the width of slab that will be affected when a concentrated load is applied.

Figures 5.14-29 illustrate strains and deflections along and across the slabs for different load patterns at a specific load magnitude. For the linear load applied across mid-span (Figure 5.3-I), the results for the slab reinforced with Microfiber-MD are not shown because this test was not performed on this slab.

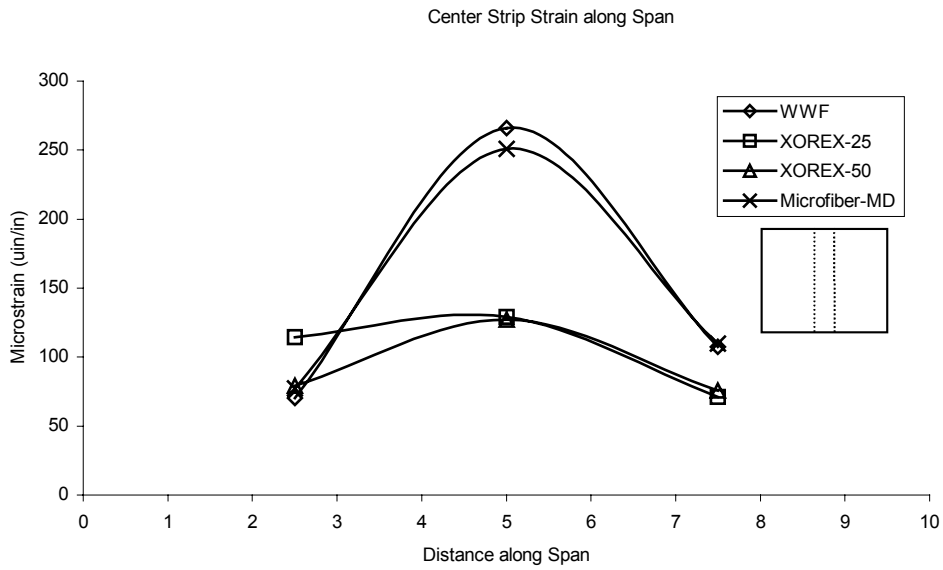

Figure 5.14- Strain along Span's Center Strip with 10 kip Concentrated Load at Mid-Span (Fig. 5.3-B)

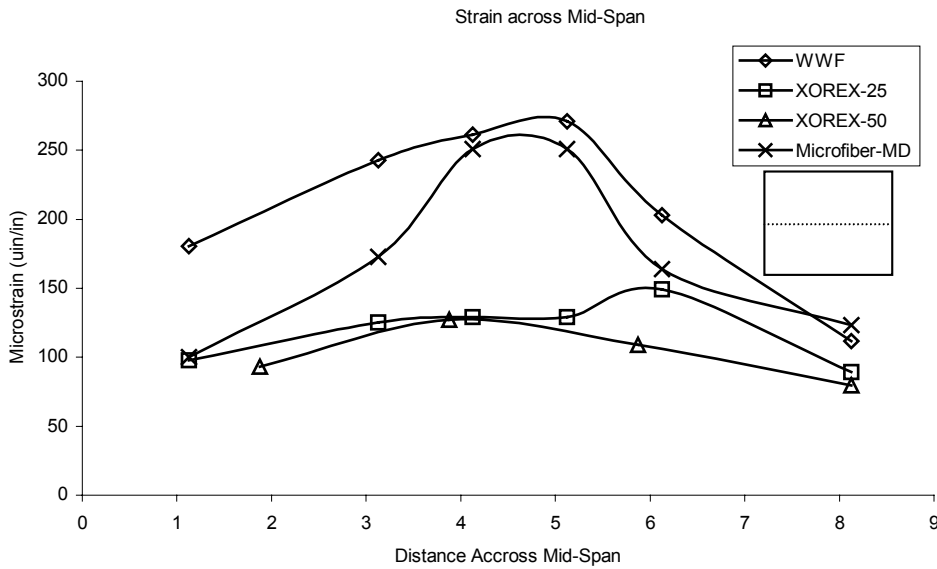

Figure 5.15- Strain across Mid-Span with 10 kip Concentrated Load at Mid-Span (Fig. 5.3-B)

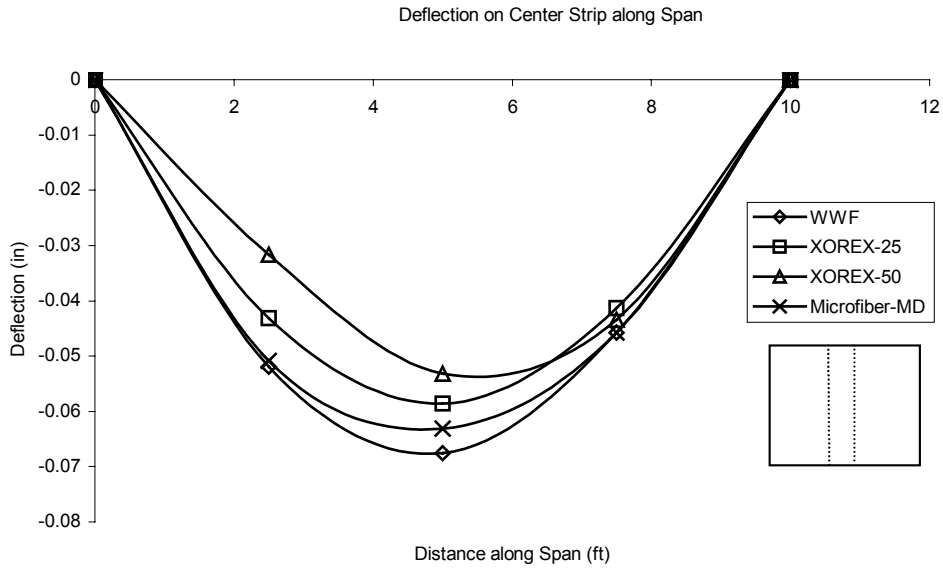

Figure 5.16- Deflection along Span's Center Strip with 10 kip Concentrated Load at Mid-Span (Fig. 5.3-B)

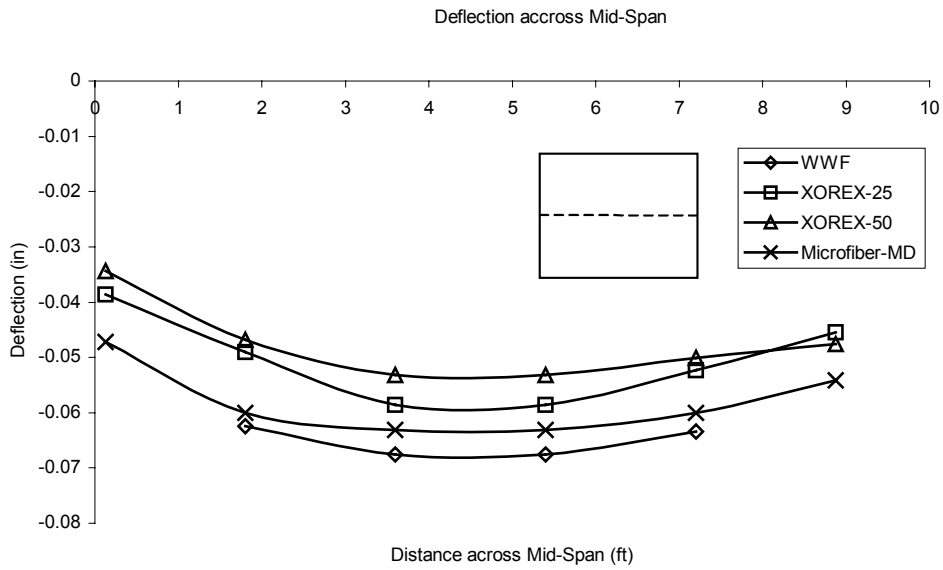

Figure 5.17- Deflection across Mid-Span with 10 kip Concentrated Load at Mid-Span (Fig. 5.3-B)

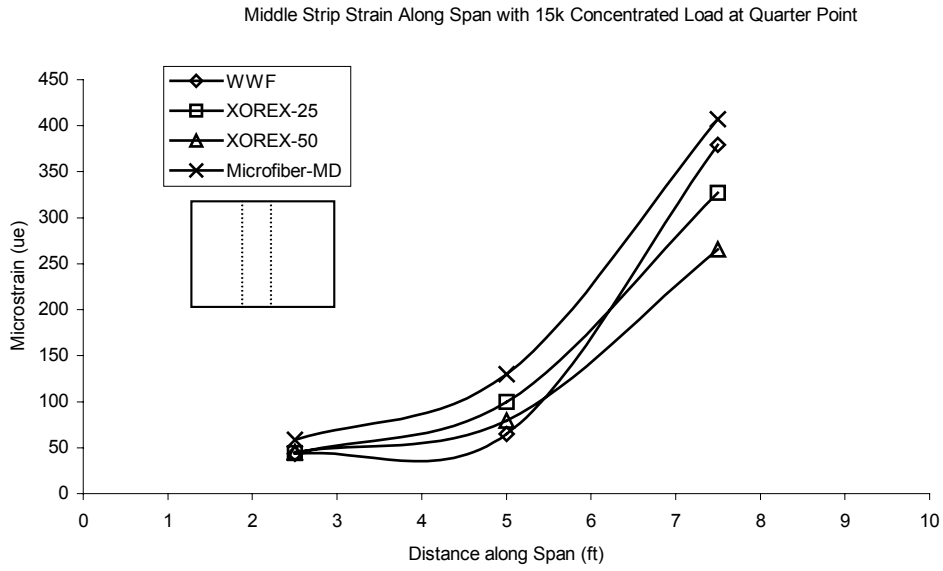

Figure 5.18- Strain along Span's Middle Strip with 15 kip Concentrated Load at Quarter Point (Fig. 5.3-A)

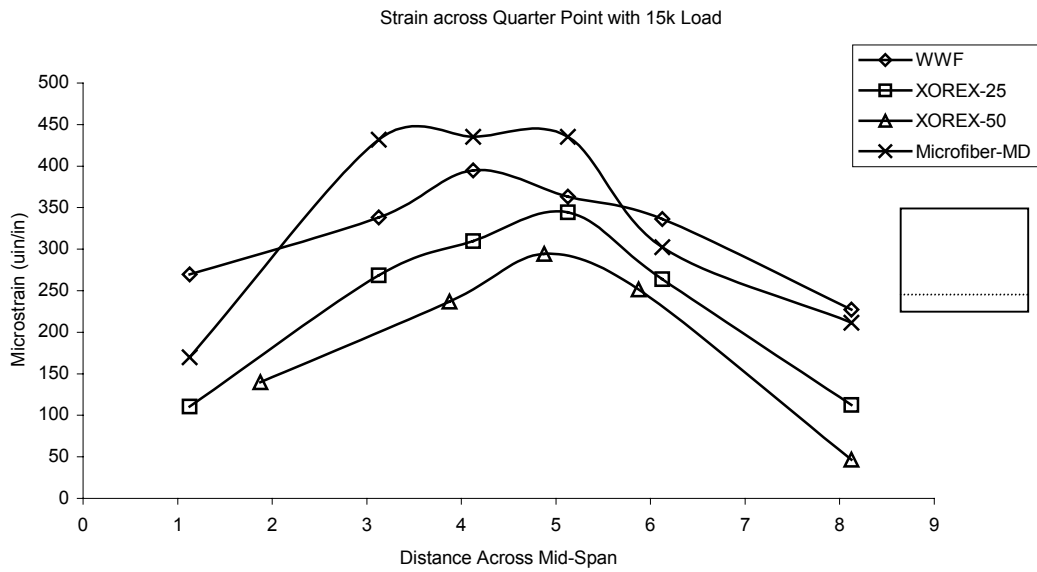

Figure 5.19- Strain across Quarter Point with 15 kip Concentrated Load at Quarter Point (Fig. 5.3-A)

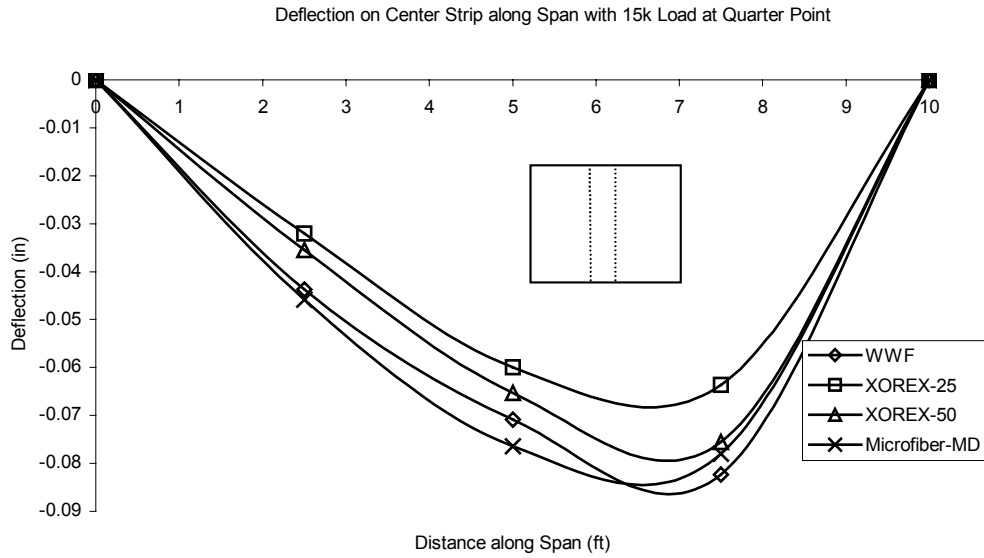

Figure 5.20- Deflection along Span's Middle Strip with 15 kip Concentrated Load at Quarter Point (Fig. 5.3-A)

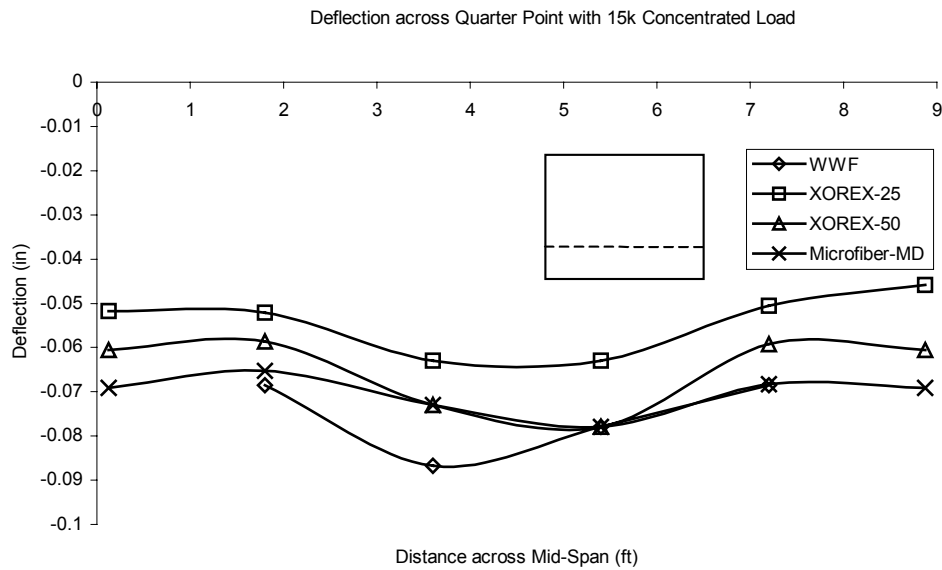

Figure 5.21- Deflection across Quarter Point with 15 kip Concentrated Load at Quarter Point (Fig. 5.3-A)

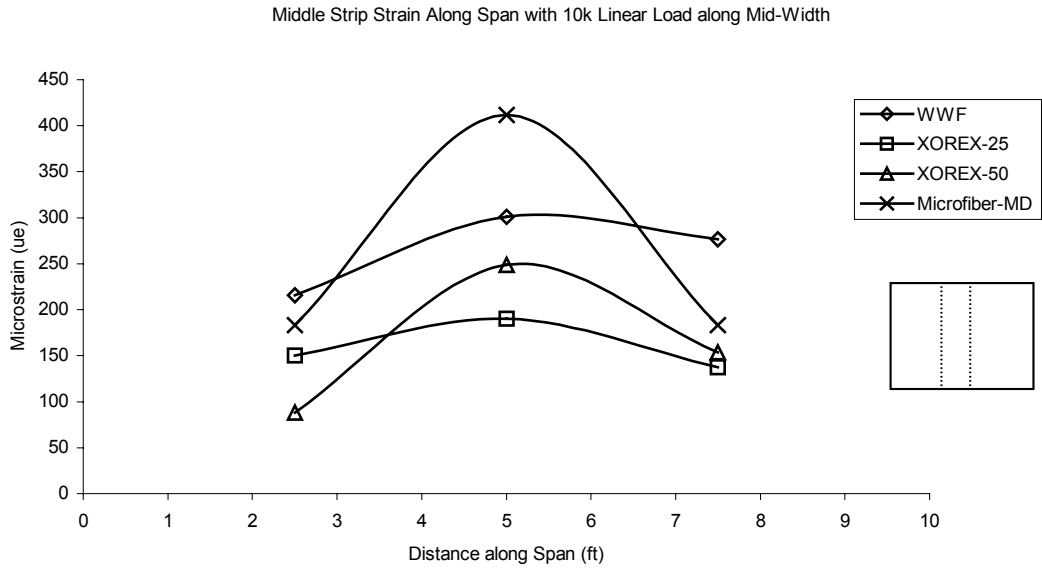

Figure 5.22- Strain along Span's Middle Strip with 10 kip Linear Load along Middle Strip (Fig. 5.3-F)

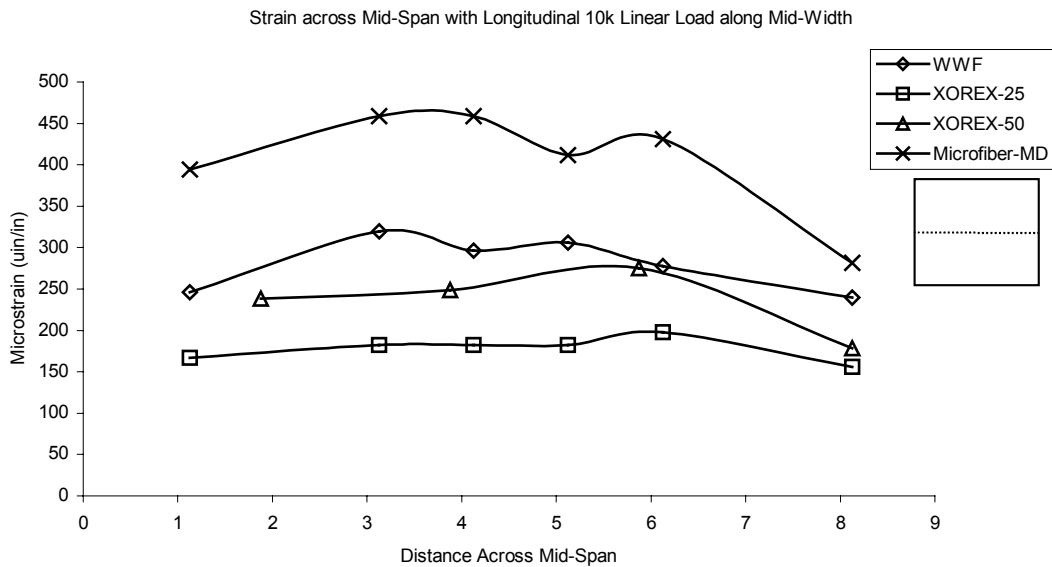

Figure 5.23- Strain across Mid-Span with 10 kip Linear Load along Middle Strip (Fig. 5.3-F)

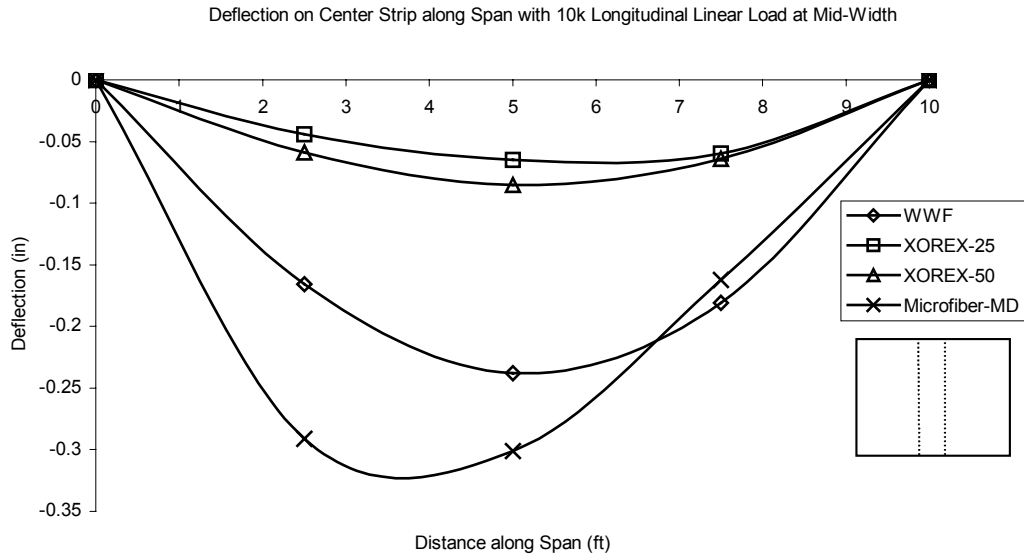

Figure 5.24- Deflection along Span's Middle Strip with 10 kip Linear Load along Middle Strip (Fig. 5.3-F)

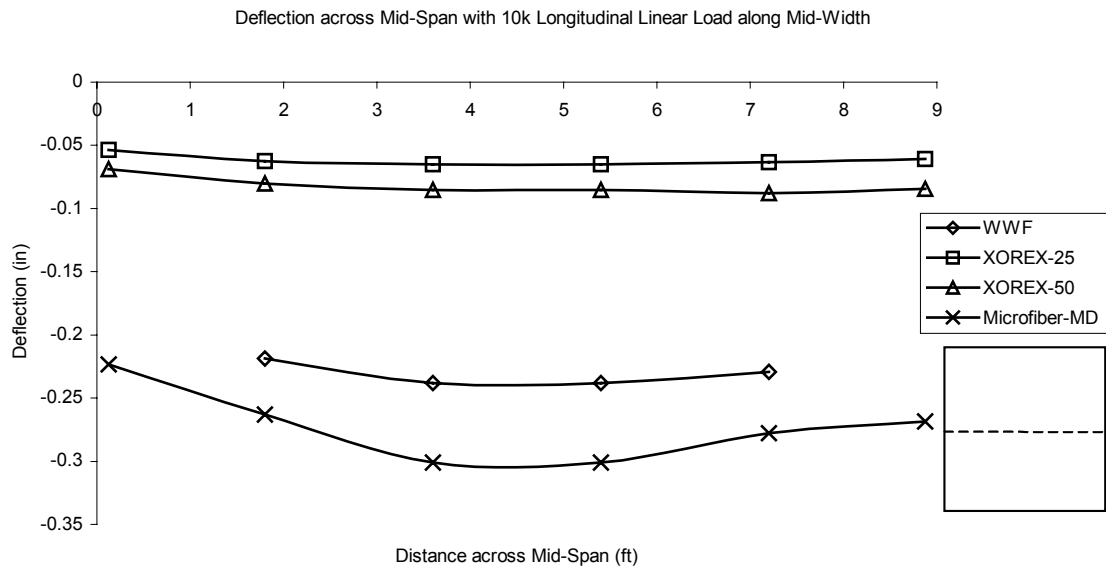

Figure 5.25- Deflection across Mid-Span with 10 kip Linear Load along Middle Strip (Fig. 5.3-F)

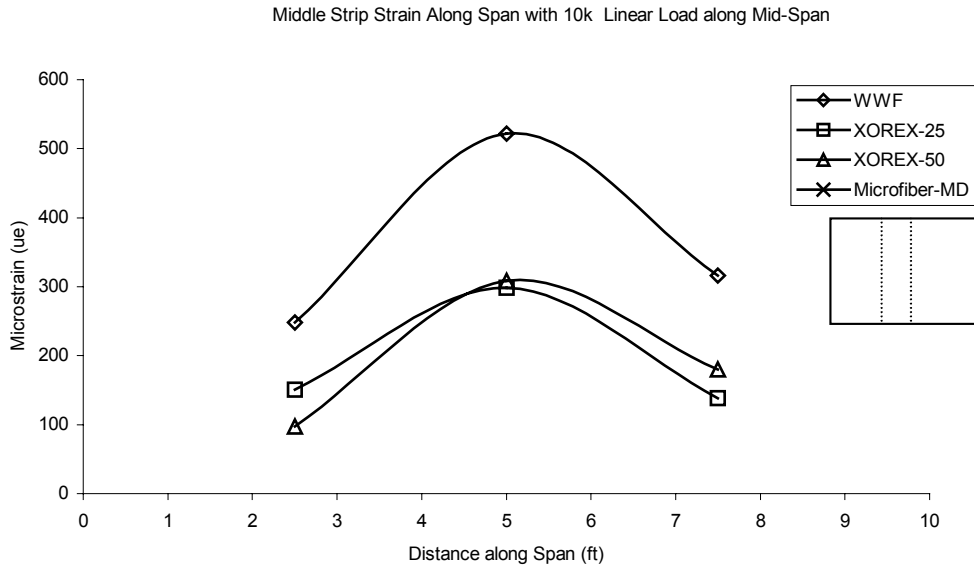

Figure 5.26- Strain along Span's Middle Strip with 10 kip Linear Load along Mid-Span (Fig. 5.3-I)

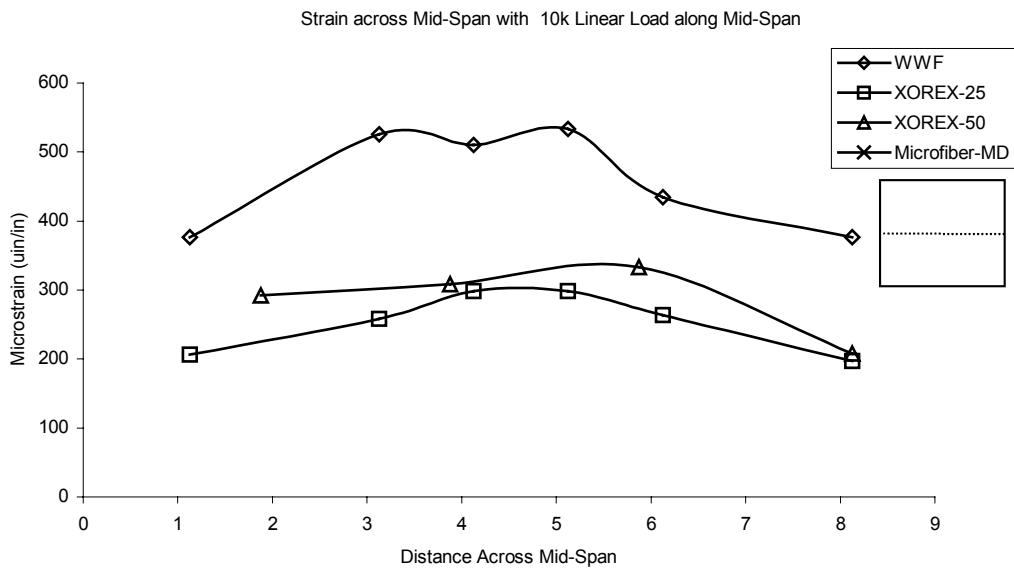

Figure 5.27- Strain across Mid-Span with 10 kip Linear Load along Mid-Span (Fig. 5.3-I)

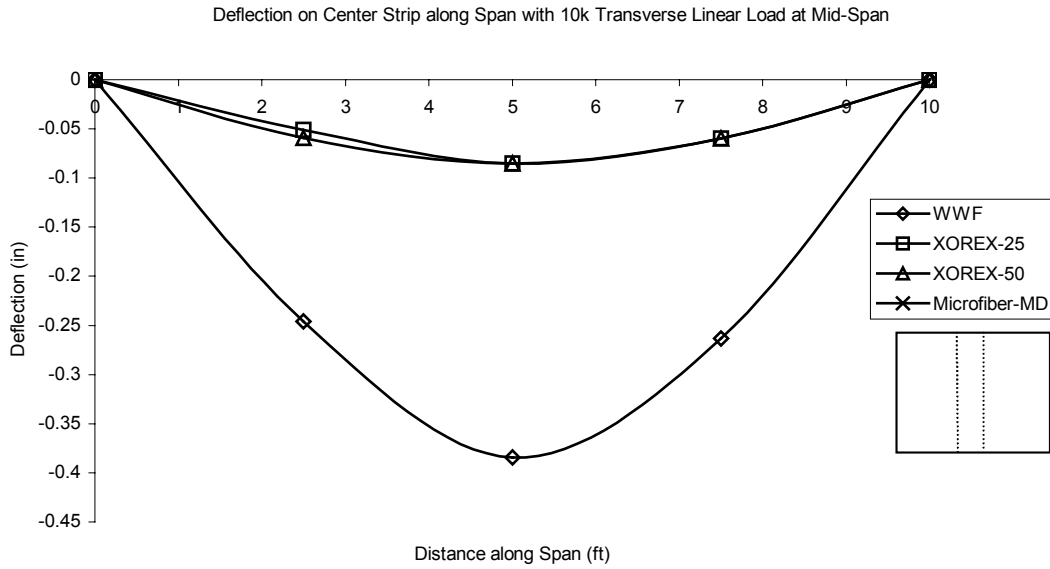

Figure 5.28- Deflection along Span's Middle Strip with Linear Load along Mid-Span (Fig. 5.3-I)

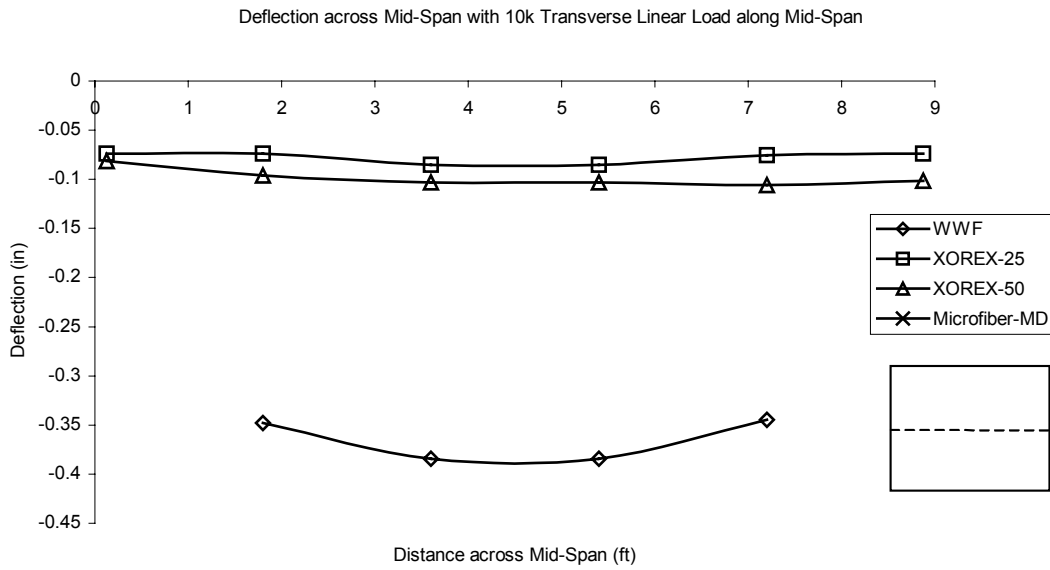

Figure 5.29- Deflection across Mid-Span with 10 kip Linear Load along Mid-Span (Fig. 5.3-I)

The results illustrated in the figures above show that at the same load magnitude and location, the slabs reinforced with XOREX steel fibers (both quantities) had smaller

strains and deflections than the slab reinforced with WWF for all cases. The slab reinforced with Microfiber-MD had smaller strains and deflections than the slab reinforced with WWF when the concentrated load was at mid-span only; and had larger strains and deflections in the other tests. This behavior can be a result of cracks that occurred during previous tests, which affect the stiffness of the slab.

5.8 CONCLUSIONS

A total of eleven tests were performed on the slabs reinforced with WWF and XOREX steel fibers. Eight tests were performed on the slab reinforced with Microfiber-MD given that it failed prior to the completion of the last three tests. Each test consisted of applying a concentrated or linear load at a different location (Figures 5.3A-K).

Results showed that at the same load magnitude and location, the slabs reinforced with XOREX steel fibers had smaller deflections and strains than the slabs reinforced with WWF and Microfiber-MD. The failure strength of the slabs were very close to the estimated strengths using the model proposed by Luttrell (1995), as opposed to the ASCE method, which underestimates the load distribution capacity of composite slabs.

Chapter 6

PUSH-OUT TESTS

EXPERIMENTAL PROGRAM

6.1 TEST PARAMETERS

A total of 24 push-out specimens were constructed allowing three specimens for each of the eight configurations described in Table 6.1.

Table 6.1 Push-Out Test Specimens – Test Matrix

No.	Deck Type	Shear Connector	Slab Depth (in)	Shear Connection Position in Rib	Shear Connector per rib	Shear Connectors per half Specimen	Secondary Reinforcement	Top Chord Angle
1	1.5 VL 22Ga	5/16" dia x 3" long ELCO Grade 8 standoff screw	3.5	Centered	1	5	WWF	2L-2x0.187
2	1.5 VL 22Ga	5/16" dia x 3" long ELCO Grade 8 standoff screw	3.5	Centered	1	5	25 lb/cy XOREX	2L-2x0.187
3	1.5 VL 22Ga	5/16" dia x 3" long ELCO Grade 8 standoff screw	3.5	Centered	1	5	50 lb/cy XOREX	2L-2x0.187
4	1.5 VL 22Ga	5/16" dia x 3" long ELCO Grade 8 standoff screw	3.5	Centered	1	5	1.5 lb/cy MD	2L-2x0.187
5	2 VL 20 Ga	3/4" dia x 4 3/8" Long Stud	6	Weak	1	2	25 lb/cy XOREX	2L-4x0.500
6	2 VL 20 Ga	3/4" dia x 4 3/8" Long Stud	6	Weak	1	2	50 lb/cy XOREX	2L-4x0.500
7	2 VL 20 Ga	3/4" dia x 4 3/8" Long Stud	6	Weak	1	2	1.5 lb/cy MD	2L-4x0.500
8	2 VL 20 Ga	3/4" dia x 4 3/8" Long Stud	6	Strong	1	2	50 lb/cy XOREX	2L-4x0.500

Deck sheets were cut to 3 ft x 3 ft for each specimen half. Pour stop was screwed to the deck. The top chord sections and the deck sheets were connected to each other with either the screws or the studs. 1 in. plates were used in the top chord sections. Double angles were welded to the plate (Figure 6.1-A).

A total of four holes per half specimen were cut on the steel deck prior to casting, allowing for displacement transducers to be nailed to the concrete after curing. Four No. 4 reinforcing bars were used in the specimens using 1.5VL-22 Ga. steel deck placed 3/4 in. above the deck. Three No. 4 bars were used in the specimens using 2VL-20 Ga. steel deck placed 1 in. above the deck. Secondary reinforcement was that specified in Table 6.1.

Each specimen consisted of two halves, which were cast separately and bolted together prior to testing. Specimens and concrete cylinders were moist cured for 7 days and air cured for at least 21 days more.

6.2 INSTRUMENTATION

A total of eight potentiometer displacement transducers were used to measure the slip between the slab and the top chord section. Four were attached at each half specimen. Load cells and hydraulic rams were used to apply shear and normal loads. All of the instrumentation was connected to a data acquisition system.

6.3 TEST SETUP

The test setup was that used by Alander et al. (1998) and is presented in Figure 6.1-A -C. Lateral bracing was also added to this setup to prevent the slab from moving sideways.

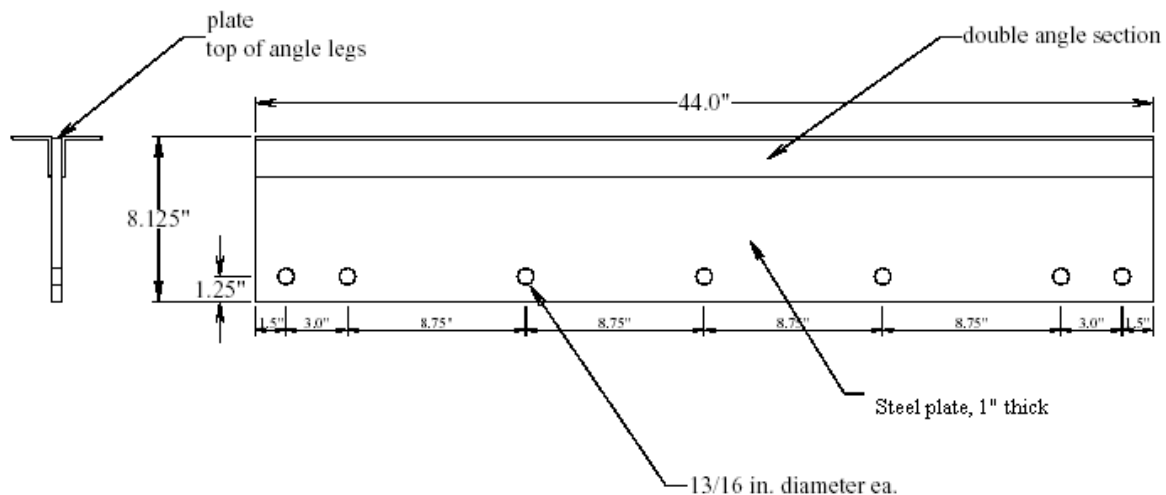

Figure 6.1-A Typical Top Chord Section (Alander et al. 1998)

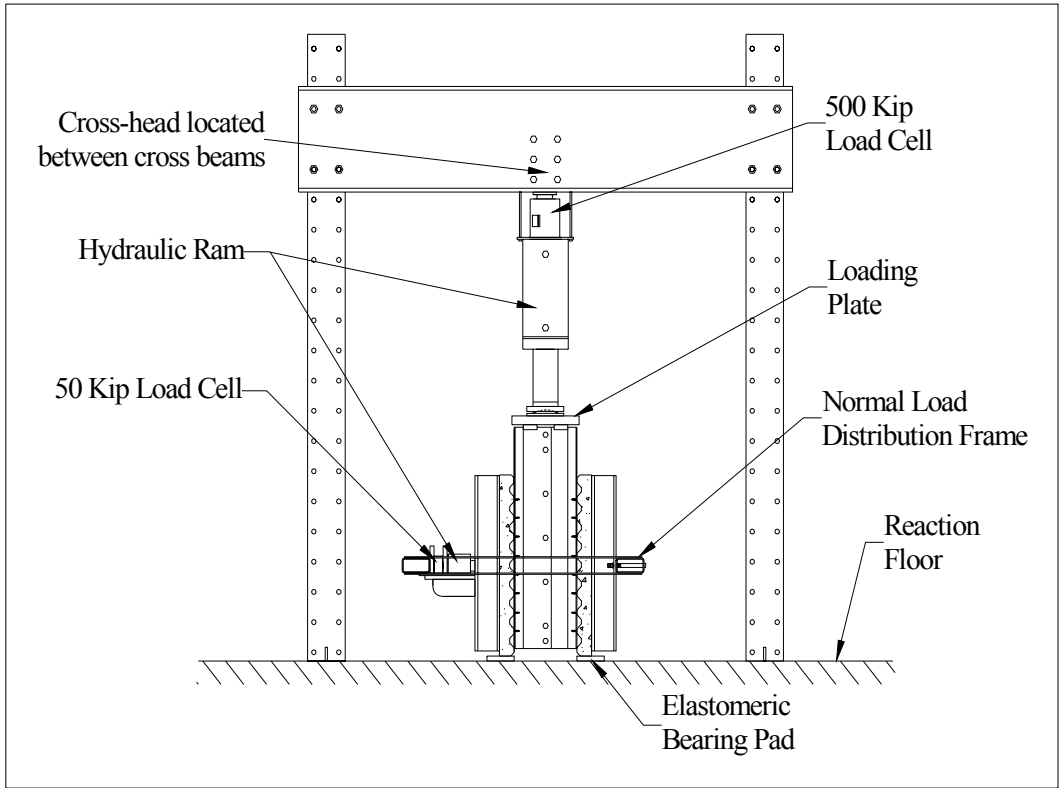

Figure 6.1-B Typical Test Setup (Alander et al. 1998)

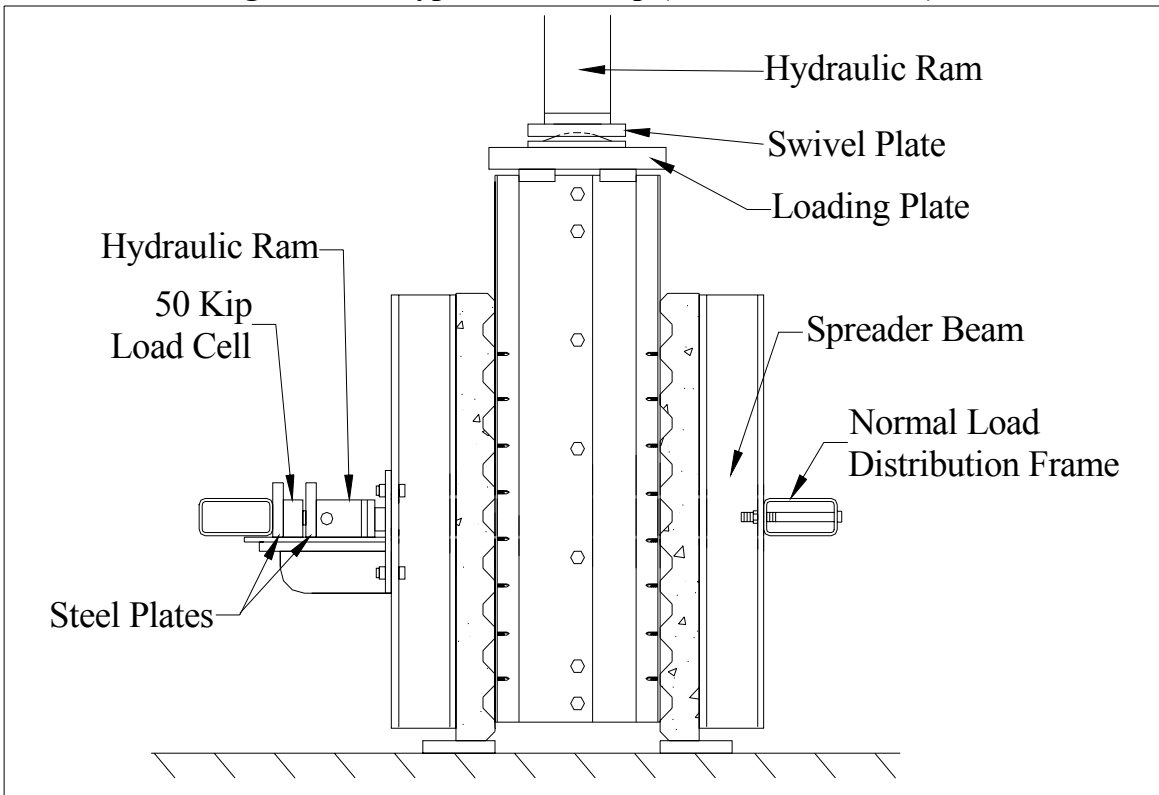

Figure 6.1-C Test Setup Detail (Alander et al. 1998)

6.4 TEST PROCEDURE

The procedure was the same for all tests. The specimen was pre-loaded to about 5-kips and then unloaded. The instrumentation was then zeroed. The shear load was applied at 5-kip increments from zero to 25-kips, and at 3-kip increments thereafter. The specimen was allowed to settle for 3 minutes between each load increment. The normal load was kept at approximately 10% of the shear load. The test was stopped when the specimen would not take any higher load. Specimens were taken apart in order to see the mode of failure.

6.5 COMPONENT TESTS

Tensile coupons were tested to obtain the actual yield strength of the deck and the steel used in the top chord section. Cylinder tests were performed in accordance to ASTM C39 standard to obtain the compressive strength of the concrete at different ages. Results for the compressive strength at test age for each individual specimen are presented in Appendix G.

6.6 RESULTS

Results for all push-out specimens are reported in Appendix G. Tables 6.2-A and B summarize those results.

Table 6.2-A Push-out Tests Results for ELCO Grade 8 Standoff Screws

Test Number	Specimen	f'_c (psi)	Peak Shear Load per screw, R_n (kips)	Observed Failure
1 (WWF)	1	3400	5.05	Screw shear
	2	3400	5.14	Screw shear
2 (XOREX-25)	1	4000	5.73	Screw shear
	2	4000	5.55	Screw shear
3 (XOREX-50)	1	4200	4.94	Screw shear
	2	4200	5.24	Screw shear
4 (Microfiber-MD)	1	3800	4.49	Screw shear
	2	3800	5.30	Screw shear

Table 6.2-B Push-out Test Results for 4- 3/8” Headed Studs

Test Number	Specimen	f _c (psi)	Peak Shear Load per Stud, R _n (kips)	Observed Failure
5- Weak Position (XOREX-25)	1	3400	12.24	Stud shear, web punching
	2	3400	13.37	Stud shear, web punching
6- Weak Position (XOREX-50)	1	4000	12.77	Stud shear, web punching
	2	4000	12.99	Stud shear, web punching
7- Weak Position (Microfiber-MD)	1	4200	12.95	Stud shear, web punching
	2	4200	11.80	Stud shear, web punching
8- Strong Position (XOREX-50)	1	3800	18.82	Stud shear
	2	3800	18.14	Stud shear

6.7 EVALUATION OF RESULTS

6.7.1 ELCO Grade-8 Standoff Screws Shear Capacity Method (Mujagic et al. 2000)

To calculate the theoretical shear capacity of the screws, the equations developed by Mujagic (2000) were used. For ribs perpendicular to the girder and a top chord thickness of 0.187 in. the equation for shear strength capacity per screw, φR_n, is given as follows:

$$R_n = \frac{0.18(Inf'_c)\ell_{sp}w_{r1}^{0.13}}{N^{0.74}} \leq \frac{0.15A_{sc}F_{ut}}{t_{tc}^{0.61}} \quad (6-1)$$

Where:

t_{tc}=top chord thickness = 0.187 in.

H_s= Screw height = 3.0 in.

h_r= rib height = 1.5 in. (for 1.5VL 22 Ga. Steel deck)

w_{r1}= bottom rib width = 1.75 in. (for 1.5VL 22 Ga. Steel deck)

f_c= concrete compressive strength; psi.

w_{r2}= top chord width = 3.5 in. (for 1.5VL 22 Ga. Steel deck)

N= number of screws in one rib not to exceed 12 =1 (for these tests)

A_{sc}= nominal cross-sectional area of screw = 0.0767 in².

F_{ut}= screw tensile strength ≈ 177 ksi.

ℓ_s = vertical distance between screws in a rib = 0 in. (for single screw per rib)

L_{sp} = length of shear plane =

$$L_{sp} = 2\sqrt{\left(\frac{w_{r2} - \ell_s}{2}\right)^2 + (H_s - h_r)^2} + \ell_s \quad (6-2)$$

The following figure illustrates some deck dimensions:

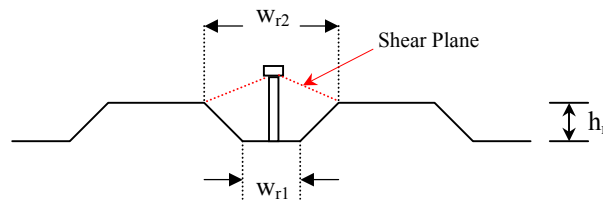

Figure 6.2 Deck Dimensions

The calculated shear strength capacities per screw obtained using equation 6-1 are presented in Table 6.2 as well as the observed shear load capacity per screw.

Table 6.2- Theoretical and Test Results for Shear Strength Capacity per Screw

Secondary Reinforcement	Specimen Number	Theoretical Shear Strength Capacity per Screw, R_n , (kips)	Observed Shear Strength Capacity per Screw, R_{no} , (kips)	R_{no}/R_n
WWF	1	5.66	5.05	0.89
	2		5.14	0.91
XOREX-25	1	5.66	5.73	1.01
	2		5.55	0.98
XOREX-50	1	5.66	4.94	0.87
	2		5.24	0.93
Microfiber-MD	1	5.66	4.49	0.79
	2		5.30	0.94
		Mean	5.18	0.915
		σ	0.355	0.067

The results from the push-out tests on specimens with ELCO Grade-8 Standoff screws were very similar between all specimens and very close to the theoretical screw strengths predicted with the method developed by Mujagic (2000). There were no major differences between specimens reinforced with fibers and specimens reinforced with

WWF. However, given that there was a single screw per rib, the failure load limit was controlled by the screw shear failure, which makes it hard to state whether or not the fiber-reinforced concrete influenced its behavior. Nevertheless, results show that specimens with fiber reinforced concrete had behavior and strength similar to specimens reinforced with WWF making the use of fiber reinforced concrete an equivalent and cost-effective alternative to WWF.

6.7.2 Theoretical Shear Strength Capacity for Headed Studs; AISC Method and Rambo-Roddenberry et al. (2001)

Two methods were used for determining the theoretical shear strength capacity per stud. The first method incorporated in the current AISC specifications gives the nominal stud strength capacity as:

$$Q_n = 0.5A_{sc}\sqrt{f'_c E_c} \leq A_{sc}F_u \quad (6-3)$$

Where:

A_{sc} = cross-sectional area of the stud

f'_c = compressive strength of concrete

E_c = modulus of elasticity of concrete = $57\sqrt{f'_c}$

F_u = minimum specified tensile stress of the stud ≈ 65 ksi

For deck ribs perpendicular to the girder, the nominal strength of the stud shear connector is multiplied by the following reduction factor:

$$SRF = \frac{0.85}{\sqrt{N_r}}(w_r / h_r)[(H_s / h_r) - 1.0] \leq 1.0 \quad (6-4)$$

Where,

N_r = number of stud connectors on a beam in one rib = 1 (for these tests)

w_r = average rib width = 6 in. (for 2VL 20 Ga. steel deck)

h_r = nominal rib height = 2 in. (for 2VL 20 Ga. steel deck)

H_s = length of shear stud after welding = 4.25 in. (for these tests)

The second method; developed by Rambo-Roddenberry et al. (2001); considers the position of the stud within the deck rib as well as other factors such as the deck thickness. The equation for nominal stud strength capacity for 2 in. deep decks is given by:

$$Q_n = R_p R_d A_{sc} F_u \quad (6-5)$$

Where,

R_p = strength coefficient based on stud position
 = 0.68 for $e_{\text{mid-ht.}} \geq 2.2'$ (strong position studs)
 = 0.48 for $e_{\text{mid-ht.}} < 2.2'$ (weak position studs)
 = 0.52 for staggered position studs

R_d = strength coefficient or deck thickness influence on weak position studs
 = 1.0 for all strong position studs
 = 0.88 for 22 ga (0.75 mm) deck (weak studs)
 = 1.0 for 20 ga (1.0 mm) deck (weak studs)
 = 1.05 for 18 ga (1.25 mm) deck (weak studs)
 = 1.11 for 16 ga (1.5 mm) deck (weak studs)

A_{sc} = cross-sectional area of the stud, in²

F_u = tensile stress of the stud, \approx 65 ksi.

The calculated nominal stud strength capacities obtained using equations 6-3, 6-4 and 6-5 are presented in Table 6.3 as well as the observed shear load capacity per stud. The results from the different fiber mixtures in the weak position studs are very similar to each other. Results for both weak and strong position studs fall in the same range of results from previous tests of specimens reinforced with WWF (Rambo-Roddenberry et al. 2001, Easterling et al. 1993, Mottram and Johnson, 1990). Once again, the use of fiber reinforced concrete replacing WWF does not result in any significant changes in the specimens' behavior.

These results also show the lack of accuracy of the current AISC Specifications design equation for welded shear studs, which is far too un-conservative. Results show that the equations proposed by Rambo-Roddenberry et al. (2001) accurately estimate the shear stud strength in both weak and strong positions.

Table 6.3- Theoretical and Test Results for Shear Strength Capacity per Stud

Secondary Reinforcement	Stud Position in Rib	Specimen Number	AISC Q_n (kips)	Rambo-Roddenberry Q_n (kips)	Observed Shear Strength, Q_o (kips)	AISC Q_o/Q_n	Rambo-Roddenberry Q_o/Q_n
XOREX-25	Weak	1	26.53	13.78	12.24	0.46	0.89
		2			13.37	0.50	0.97
XOREX-50	Weak	1	27.51	13.78	12.77	0.46	0.93
		2			12.99	0.47	0.94
Microfiber-MD	Weak	1	25.52	13.78	12.95	0.51	0.94
		2			11.80	0.46	0.86
XOREX-50	Strong	1	27.51	19.53	18.82	0.68	0.96
		2			18.14	0.66	0.93

6.8 CONCLUSIONS

There were no major differences in the performance of specimens reinforced with WWF and those with fiber-reinforced concrete. Given that single screws per rib were used, the failure mode was controlled by screw shear rather than concrete crushing making it hard to predict whether or not the concrete mixture would have made a difference. Nevertheless, the performance of fiber-reinforced concrete once again proved to be equivalent to that of WWF.

Chapter 7

SUMMARY, CONCLUSIONS AND RECOMMENDATIONS

7.1 SUMMARY

Most steel-framed buildings constructed today use composite slabs, where the steel deck serves as the tensile reinforcement. In most cases, no additional reinforcement is required for strength, but for serviceability reasons, temperature and shrinkage reinforcement is added most commonly in the form of welded wire fabric (WWF).

The use of fiber-reinforced concrete is an attractive alternative to WWF because it reduces shipping costs and is easier to handle. This study focused on the behavior and strength of fiber-reinforced composite slabs compared to WWF, with the purpose of providing the necessary data to support the use of fibers as an equivalent alternative to WWF. The relative serviceability performance of the WWF and the fibers with respect to the control of temperature and shrinkage cracks was not addressed in this work. The fiber mixtures considered in this study were 1 ½” XOREX steel fibers in the amounts of 25 and 50 lb/yd³ and a synthetic fiber (Microfiber-MD) in the amount of 1.5 lb/yd³.

Push-out tests with ELCO Grade 8 screws and headed studs were performed to at least two specimens of each type of fiber mixture. The shear strength of the screws and the studs was examined but there was no major difference in their behavior that would suggest an influence of the fibers in the concrete mixtures. Specimens failed in screw and stud shear rather than in concrete related failure. The theoretical screw shear strength was calculated using a method developed by Mujagic (2000). This method considers three failure modes: screw pullout, concrete rib failure and screw shear failure, which was the dominant failure mode in these tests. The nominal stud shear strength capacity was estimated using the current AISC Specifications, which applies a stud reduction factor, SRF, to the regular equation for studs in reinforced concrete slabs. This method is considered by many to be unconservative. A second set of equations developed by Rambo-Roddenberry et al. (2001) were used, which considers the position of the stud within the deck rib as well as other factors that influence the stud strength. This method produced more accurate estimates of the actual test strengths.

Full-scale slab tests were performed with distributed and non-distributed (concentrated and linear) loads. Measurements, such as applied load, deflections, strains, end slip and cracking, were taken and compared with slabs reinforced with WWF. Current standard design methods were used for determining the theoretical moment capacity of the slabs. These methods have been developed analytically with the purpose of predicting composite slab strengths without going through the expensive and time-consuming process of full-scale testing. The methods used in this study for the slabs with distributed load were the First Yield Method and the ASCE Appendix D Alternate Method of Design (Standard, 1994). The ASCE Method was also used for the slabs with concentrated and linear loads as well as a method developed by Charles Luttrell (1995) for “Transverse Distribution of Non-Uniform Loads on Composite Slabs”, which predicted the slabs’ strengths accurately. The ASCE Standard lacks a method of predicting transverse distribution of load in composite slabs.

Standard ASTM C1018 tests for “Flexural Toughness and First-Crack Strength of Fiber-Reinforced Concrete” were performed for specimens with fibers. Results from these tests were compared to results of equivalent tests performed by Synthetic Industries.

7.2 CONCLUSIONS

As a result of this study, the following conclusions were made:

Slabs under Distributed Load Test Conclusions

- All slabs failed in a similar manner and followed the same pattern.
- Slabs reinforced with 50 lb/yd³ of XOREX steel fibers had higher ultimate strengths than slabs reinforced with WWF (approximately 18%). Some of this increase in strength may also be attributed to the higher concrete compressive strength.
- An increase in XOREX steel fiber dosage (from 25 to 50-lb/yd³) increased the ultimate strength (approximately 37%).
- Slabs reinforced with 1.5 lb/yd³ of Microfiber-MD failed at loads equivalent to slabs reinforced with WWF.

- At equivalent load, fiber-reinforced concrete slabs had a smaller opening of the crack over the concrete surface along the interior support.
- There are no major differences in the behavior and strength of slabs reinforced with WWF or with fiber-reinforced concrete. At a typical design load of 70 psf, all slabs had a similar and linear load-deflection relationship. Mid-span deflections at this load magnitude were small and met serviceability deflection requirements.
- The ease of mixing the fibers with the concrete is an advantage over the tedious process of placing the WWF correctly.
- Shipping costs can be reduced when using fibers instead of WWF.
- A disadvantage of fiber-reinforced concrete over WWF is the quality of the surface finishing. Particularly with the synthetic fibers, the surface has a “hairy” appearance.

Slabs with Concentrated and Linear Loads Test Conclusions

- All slabs showed similar behavior.
- At equivalent load magnitudes, the slabs reinforced with XOREX steel fibers had smaller deflections and strains than the slab reinforced with WWF.
- The ASCE method underestimates the load distribution capacity of composite slabs with non-distributed loads.
- The method developed by Luttrell (1995) provides an accurate estimate of the slabs’ moment capacity for non-distributed loads and is applicable to slabs reinforced with WWF or fiber-reinforced concrete.
- Fiber reinforced concrete is an equivalent alternative to WWF.

Push-Out Test Conclusions

- Failure of the tested specimens occurred due to screw and stud shear rather than concrete crushing, making it hard to predict any influence of the concrete mixture.

- The use of fiber-reinforced concrete in place of WWF produced no visible changes in the behavior of Grade 8 ELCO standoff screws placed single in a rib.
- The method developed by Mujagic (2000) for predicting screw shear strength is also applicable to fiber-reinforced concrete specimens.
- Fiber-reinforced concrete specimens with headed studs had similar results as tests done in previous researches where WWF was used.
- The method developed by Rambo-Roddenberry et al. (2001) is also applicable to fiber-reinforced concrete specimens and results in more accurate predictions of nominal stud strength than the AISC method, which is un-conservative.

7.3 RECOMMENDATIONS FOR FUTURE RESEARCH

The use of the fiber-reinforced concrete mixtures evaluated showed similar behavior to specimens with WWF. However, this study only used three different fiber mixtures. Studies considering other sizes, types and quantities of fibers could be useful for determining the most cost effective product that does not sacrifice strength.

A study that analyzes if there is some effect of the fibers on the mechanical bonding between the concrete and the steel deck could be useful and advantageous for the product.

The relative serviceability performance of the fibers with respect to temperature and shrinkage cracks is important in order to study which material performs better for crack control.

The adhesion properties of the finished concrete should be addressed in order to determine any advantages or problems that could arise when placing tile or carpet over the slab.

Push-out tests with more than one screw or stud per rib where the controlling failure mode is concrete related should be performed. In this way, any influence of the fibers on the performance of the shear connectors would become apparent.

Existing strength prediction methods need to make changes for estimating stud strength and load distribution in composite slabs.

REFERENCES

Alander, C.C., Easterling, W.S., Murray, T.M., (1998). "Standoff Screws used in Composite Joists." Report No. CE/VPI-St. 98/03, Virginia Polytechnic Institute and State University, Blacksburg, Virginia.

ASCE Standard for the Structural Design of Composite Slabs (1992). Steel Deck with Concrete Standards Committee of Management Group F, Codes and Standards, ASCE, 345 East 47th Street, New York, NY 10017-2398

ASTM C1018-97 (1998) "*Standard Test Method for Flexural Toughness and First Crack Strength of Fiber-Reinforced Concrete*", West Conshohocken, PA.

ASTM C78-94 (1998) "*Standard Test Method for Flexural Strength of Concrete*", West Conshohocken, PA.

ASTM C39-96 (1998) "*Standard Test Method for Compressive Strength of Cylindrical Concrete Specimens*", West Conshohocken, PA.

ASTM C192 (1998) "*Standard Practice for Making and Curing Test Specimens in the Laboratory*", West Conshohocken, PA.

ASTM E8-00b (1998) "*Standard Test Method for Tension Testing of Metallic Materials*", West Conshohocken, PA.

Easterling, W.S., Gibbins, D.R. and Murray, T.M. (1993). "Strength of Shear Studs in Steel Deck on Composite Beams and Joists." *Engineering Journal*, AISC, 30(2), pp. 44-55

Easterling, W.S. and Young, C. Y. (1992). "Strength of Composite Slabs", *Journal of Structural Engineering*, ASCE, 118(9), pp. 2370-2389

Fisher, J.W. (1970). "Design of Composite Beams with Formed Metal Deck." *Engineering Journal*, AISC, 3(7), pp. 88-96.

Grant, J.A., Fisher, J.W. and Slutter, R.G. (1977). "Composite Beams with Formed Steel Deck." *Engineering Journal*, AISC, 14(1), pp. 24-43.

Hankins, S.C., Gibbings, D.R., Easterling, W.S., Murray, T.M., (1995). "Standoff Screws Functioning as Shear Connectors in Composite Joists." Report No. CE/VPI-ST 94/16, Virginia Polytechnic Institute and State University, Blacksburg, Virginia.

Hawkins, N.M., and Mitchell, D.M., (1984). "Seismic Response of Composite Shear Connections." *Journal of Structural Engineering*, ASCE, 110(9), pp. 2120-2136.

Heagler, R.B., Easterling, W.S., Luttrell, L.D. (1993). "The Steel Deck Institute Method for Composite Slab Design." [Conference Paper] Composite Construction in Steel and Concrete II Proc. Eng. Found. Conf. Published by ASCE New York, NY, pp.287-303

Ibrahim, E., Jannoulakis, E., (1994). "Steel Fibre Reinforcement in Composite Decks." M.S. Thesis, McGill University, Montreal, Quebec, Canada

Lauer, D.F., Gibbings, D.R., Easterling, W.S., Murray, T.M., (1995). "Short Span Composite Joists." Report No. CE/VPI-ST 96/06, Virginia Polytechnic Institute and State University, Blacksburg, Virginia.

Lloyd, R.M. and Wright, H.D. (1990). "Shear Connection between Composite Slabs and Steel Beams." *Journal of Construction Steel Research*, 15(4), pp. 255-285

LRFD Manual of Steel Construction, Vol. I, (1994). American Institute of Steel Construction, Inc, Chicago, IL

Luttrell, C.B. (1995). "Transverse Distribution of Non-Uniform Loads on Composite Slabs." M.S. Thesis West Virginia University, Morgantown, West Virginia.

Mottram, J.T. and Johnson, R.P. (1990). "Push tests on studs welded through profiled steel sheeting." *The Structural Engineer*, 68(10), pp. 187-193

Mujagic, U. (2000). "Strength Calculation Model for Standoff Screws in Composite Joists." M.S. Thesis, Virginia Polytechnic Institute and State University, Blacksburg, Virginia.

Mullenex, D.L., (1993). "The Effects of Rust and Concentrated Loads on Composite Slabs." M.S. Thesis, West Virginia University, Morgantown, West Virginia.

Oehler, D.J. (1989). "Splitting Induced by Shear Connectors in Composite Beams." *Journal of Structural Engineering*, ASCE, 115(2), 341-362.

Porter, M.L., (1985). "Analysis of Two-Way Acting Composite Slabs." *Journal of Structural Engineering*, January, 111(1), pp.1-17.

Rambo-Roddenberry, M.R., Lyons, J.C., Easterling, W.S. and Murray, T.M. (2001). "Performance and Strength of Welded Shear Studs." *Composite Construction in Steel and Concrete IV*, Proceedings of an Engineering Foundation Conference, ASCE, New York, to appear

Robinson, H. (1967). "Tests of Composite Beams with Cellular Deck." *Journal of the Structural Division*, ASCE, 93(ST4), pp. 139-163.

Roeder, C.W., (1981). "Point Loads on Composite Deck-Reinforced Slabs." *Journal of the Structural Division*, 107(ST12), ASCE, pp.2421-2429.

Slutter, R.G. and Driscoll, G.C. (1965). "Flexural Strength of Steel-Concrete Composite Beams." *Journal of the Structural Division*, ASCE, 91(2), pp. 71-99.

Strocchia, L.D., Easterling, W.S., and Murray, T.M., (1991). "Evaluation of Deck Fasteners Functioning as Shear Connectors for Composite Steel Joists." Report No. CE/VPI-ST 91/01, Virginia Polytechnic Institute and State University, Blacksburg, Virginia.

Student Manual for Strain Gage Technology (1992). Measurement Group, Inc. Raleigh, NC.

Terry, A. and Easterling, W.S. (1994). "The Effects of Typical Construction Details on the Strength of Composite Slabs." Report No. CE/VPI-ST 94/05, Virginia Polytechnic Institute and State University, Blacksburg, Virginia..

Webler, J.E., Easterling, W.S., and Murray, T.M., (2000). "Further Investigation on Standoff Screws used in Composite Joists." Report No. CE/VPI-ST 00/18, Virginia Polytechnic Institute and State University, Blacksburg, Virginia.

APPENDIX A: WWF-COMPOSITE SLABS UNDER DISTRIBUTED LOAD TEST PLOTS

Results from the slabs reinforced with WWF tested under distributed load are illustrated in the graphs presented in this Appendix. Each set of results includes a summary of test parameters, casting strains, concrete and steel properties, and graphs of the applied load vs. Mid-Span Deflection, End Slip, bottom and top flange strains along the span, crack width along interior support and interior and exterior quarter-point deflection.

Some additional dimensions of the deck and embossments are illustrated below:

Embossment Dimensions:

N_{b-v} : 0.67 in. N_{b-h} : 1.85 in. W_b : 0.68 in. s : 3.36 in.

N_{t-v} : 1.59 in. N_{t-h} : 1.57 in. W_t : 0.25 in. p_h : 0.10 in.

Deck Cross-Section:

D_w : 2.24 in.

B_b : 5.0 in.

B_t : 5.0 in.

C_s : 12 in.

Test Designation: WWF-1
Cast Date: 10/12/2000
Test Date: 11/15/2000

Materials and Dimensions

General:

Width: 6 ft (2 panels)
Span length: 10 ft.
Intermediate Span Length: 4 ft.
Type of Reinforcement: Welded Wire Fabric

Deck:

Deck type: 2VLI-20
Design Thickness: 0.0358 in
Height: 2 in
Area: 0.519 in²/ft
Yield Stress: 50 ksi
Ultimate Strength: 60 ksi

Concrete:

Test Strength: 3800 psi
Total Depth: 4.5 in

Results

Maximum Applied Load: 367 psf
Mid-Span Deflection at Maximum Load: 0.81 in
Interior Quarter Point Deflection at Maximum Load: 0.46 in
Exterior Quarter Point Deflection at Maximum Load: 0.66 in
End Slip at Maximum Load: 0.07 in

Strains Due to Fresh Concrete (µε)

1SG1A	1SG1B	1SG2A	1SG2B	1SG3A	1SG3B	1SG4A	1SG4B	1SG5A	1SG5B	1SG6A	1SG6B
206.62	-187.05	370.23	-338.2	428.5	-387.62	365.54	-318.8	171.54	-186.93	-85.389	58.196

Steel Deck Strain Gage Locations

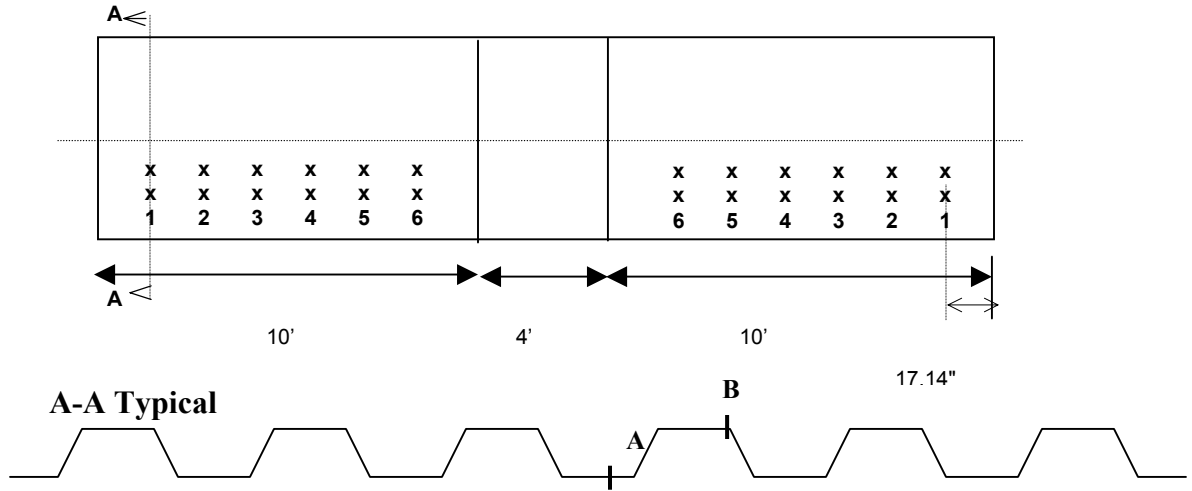

Potentiometer and Wire Pot Locations (Top View)

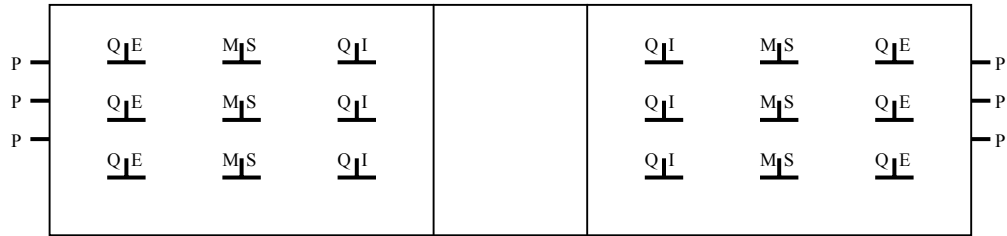

- P — Potentiometer
- Q1E Exterior Quarter Point Wire Pot
- M1S Mid-Span Wire Pot
- Q1I Interior Quarter Point Wire Pot

Potentiometer Locations at Each Side of Slab (Side View)

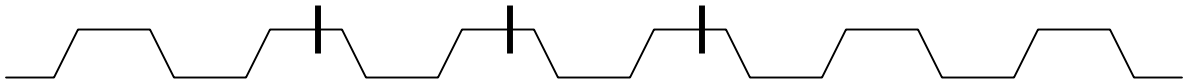

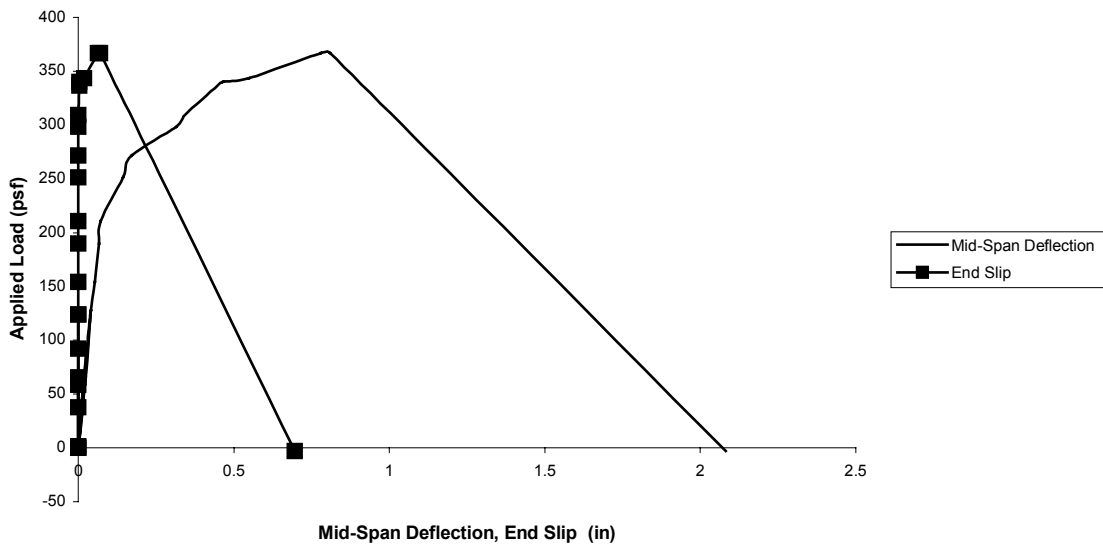

Figure A.1 WWF-1 Applied Load vs. Mid-Span Deflection and End Slip

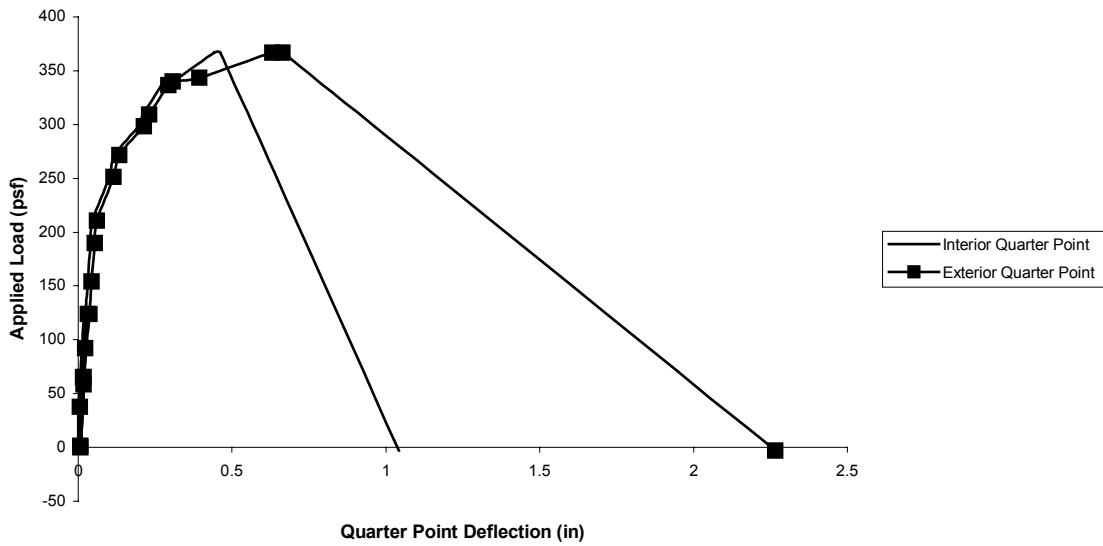

Figure A.2 WWF-1 Applied Load vs. Quarter Point Deflection

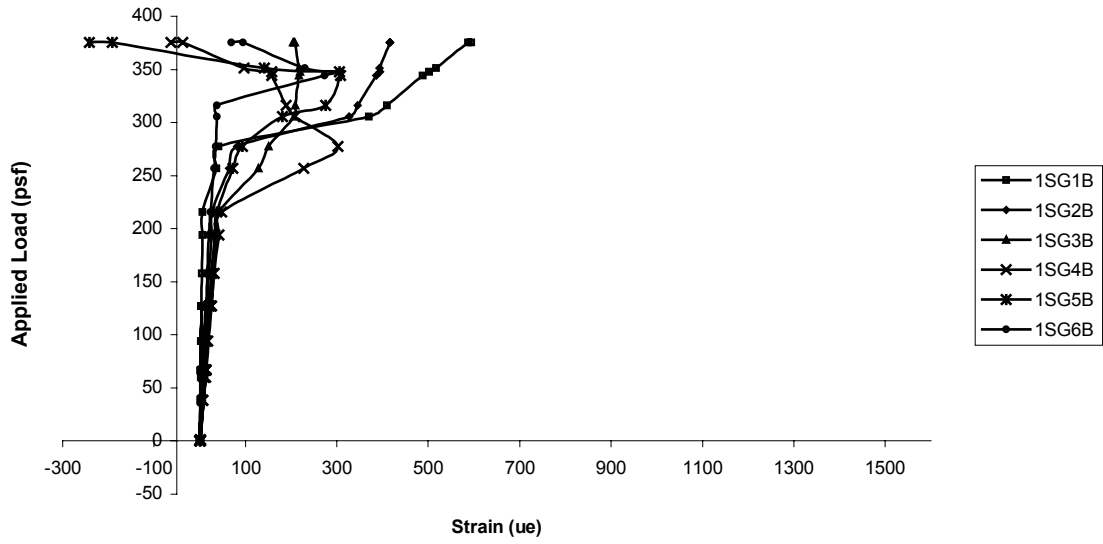

Figure A.3 WWF-1 Applied Load vs. Strain in Deck Top Flange along Span

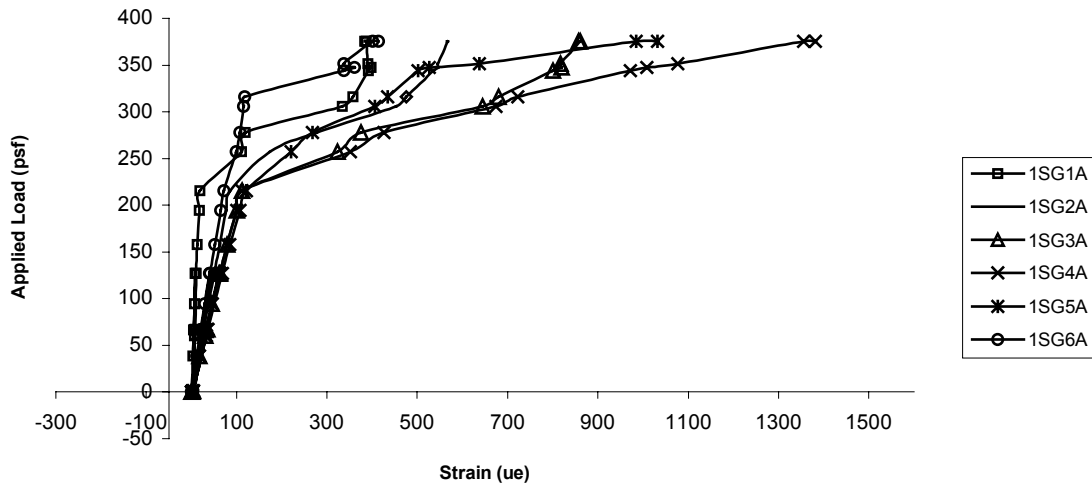

Figure A.4 WWF-1 Applied Load vs. Strain in Deck Bottom Flange along Span

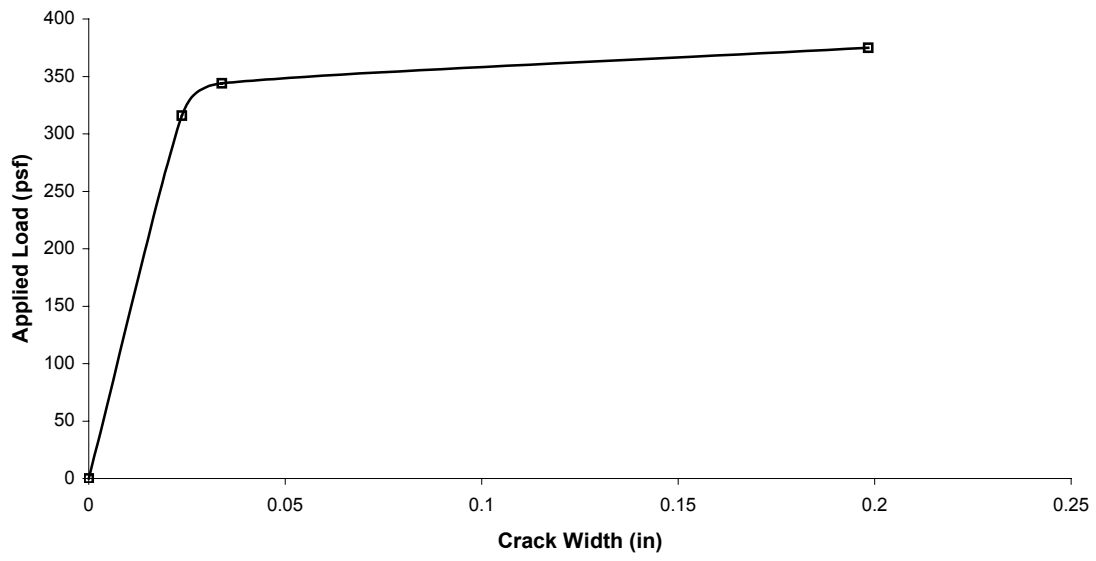

Figure A.5 WWF-1 Applied Load vs. Crack Width at Interior Support

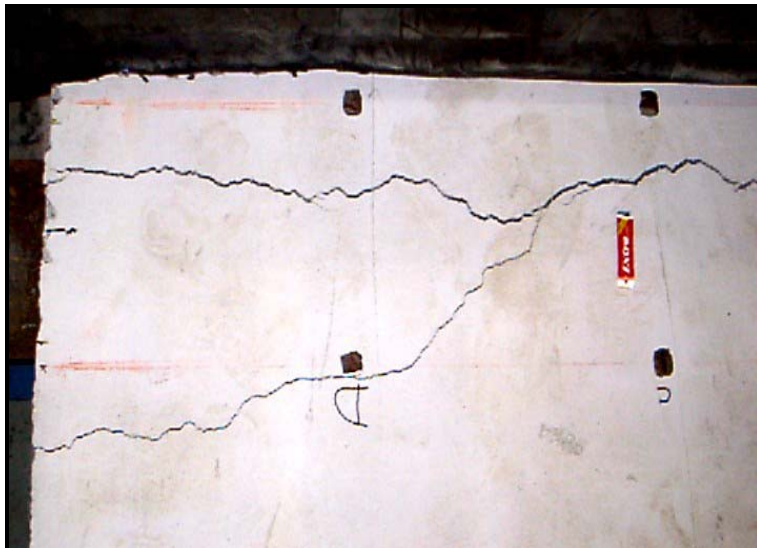

Figure A.6 WWF-1 Crack Over Interior Support

Test Designation: WWF-2
Cast Date: 10/12/2000
Test Date: 11/15/2000

Materials and Dimensions

General:

Width: 6 ft (2 panels)
Span length: 10 ft.
Intermediate Span Length: 4 ft.
Type of Reinforcement: Welded Wire Fabric

Deck:

Deck type: 2VLI-20
Design Thickness: 0.0358 in
Height: 2 in
Area: 0.519 in²/ft
Yield Stress: 50 ksi
Ultimate Strength: 60 ksi

Concrete:

Test Strength: 3800 psi
Total Depth: 4.5 in

Results

Maximum Applied Load: 337 psf
Mid-Span Deflection at Maximum Load: 1.05 in
Interior Quarter Point Deflection at Maximum Load: 0.55 in
Exterior Quarter Point Deflection at Maximum Load: 0.80 in
End Slip at Maximum Load: 0.06 in

Strains Due to Fresh Concrete (µε)

2SG1A	2SG1B	2SG2A	2SG2B	2SG3A	2SG3B	2SG4A	2SG4B	2SG5A	2SG5B	2SG6A	2SG6B
230	-183	402	-375	466	-420	400.51	-357.5	211.36	-193.79	-77.52	74.633

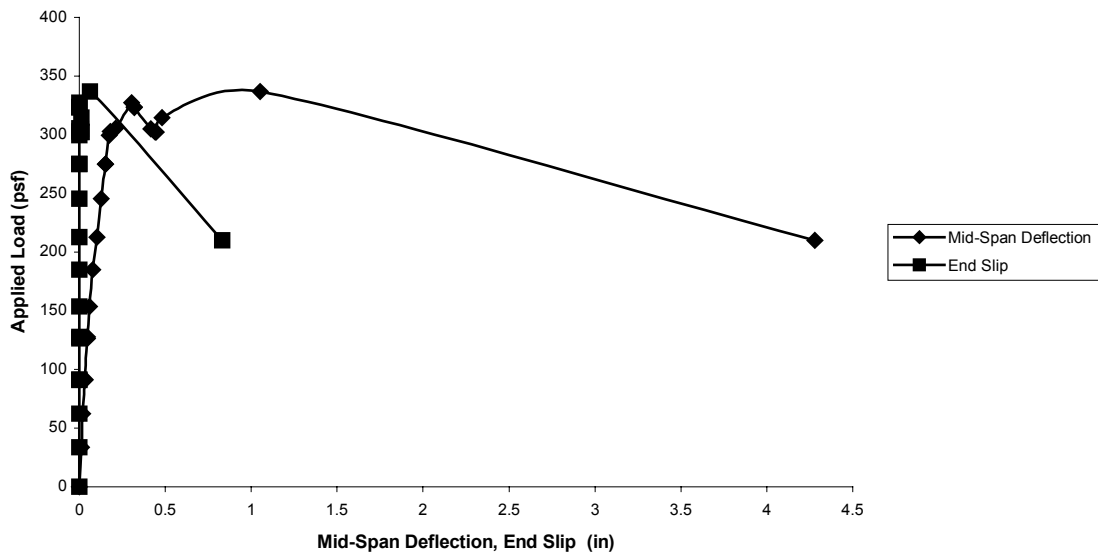

Figure A.6 WWF-2 Applied Load vs. Mid-Span Deflection and End Slip

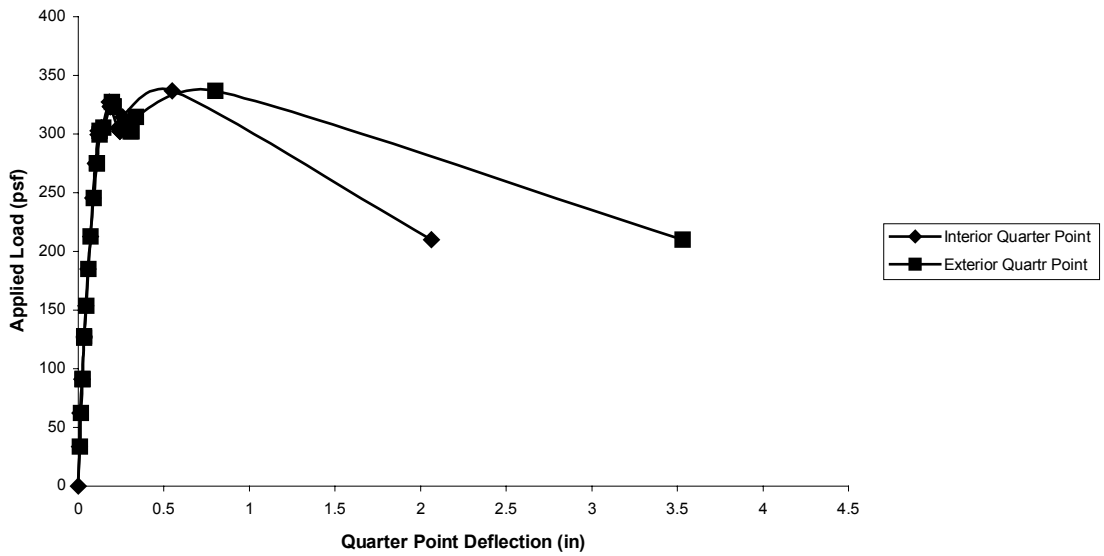

Figure A.7 WWF-2 Applied Load vs. Quarter Point Deflection

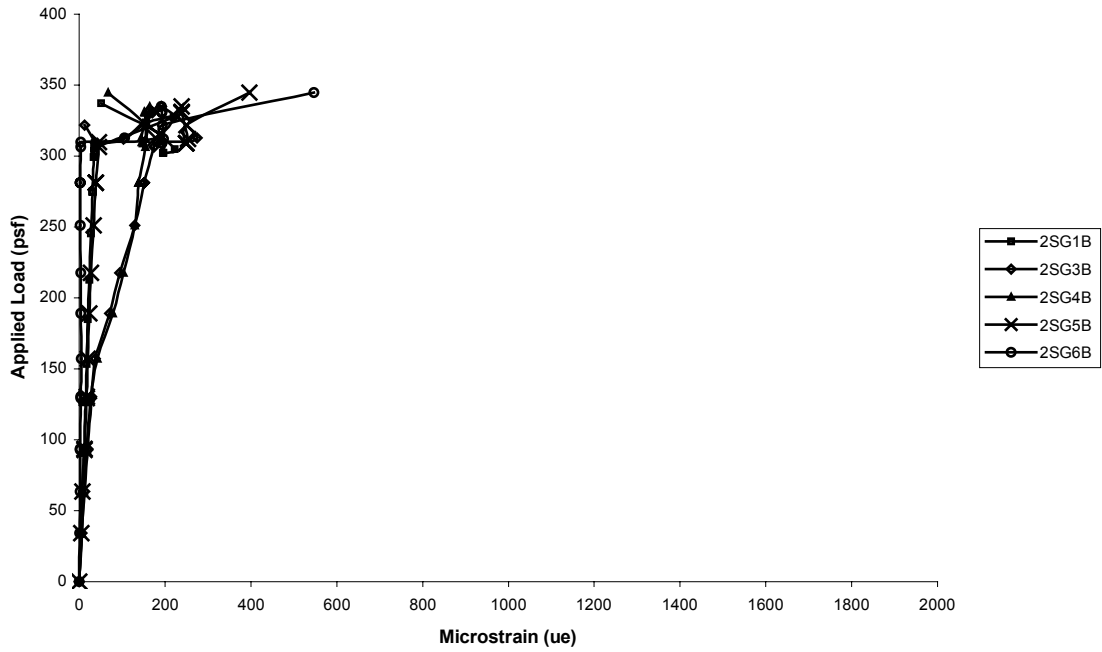

Figure A.8 WWF-2 Applied Load vs. Strain in Deck Top Flange along Span

(WWF-Test 2) Bottom FL Strain along span

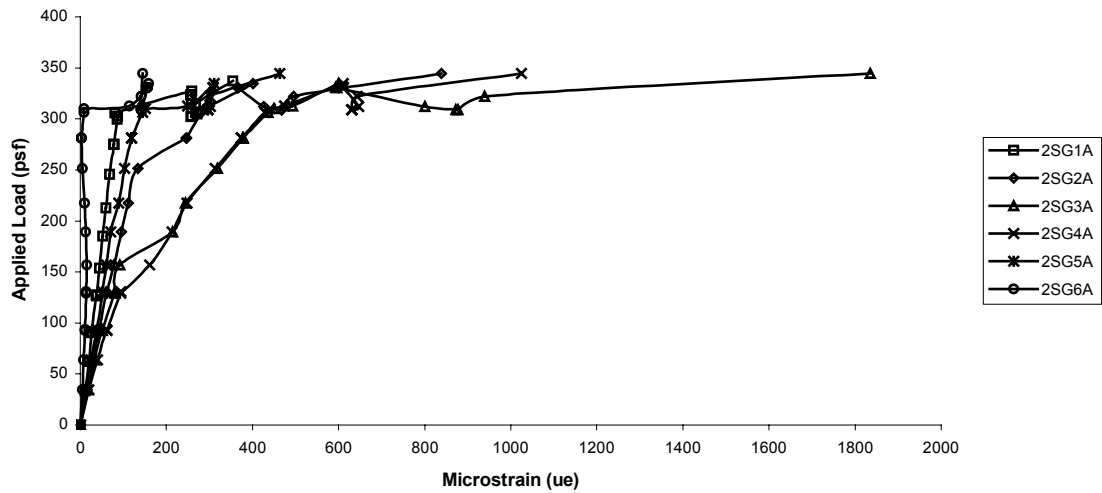

Figure A.9 WWF-2 Applied Load vs. Strain in Deck Bottom Flange along Span

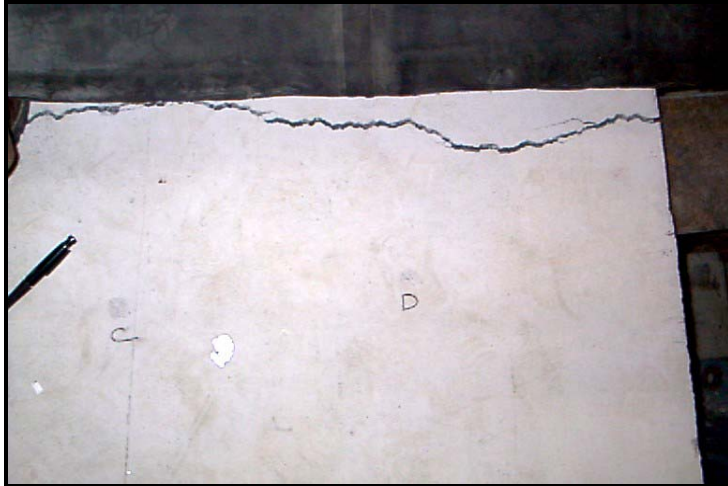

Figure A.11 WWF-2 Crack Over Interior Support

APPENDIX B: XOREX-25-COMPOSITE SLABS UNDER DISTRIBUTED LOAD TEST PLOTS

Results from the slabs reinforced with 25 lb/yd³ XOREX steel fibers tested under distributed load are illustrated in the graphs presented in this Appendix. Each set of results includes a summary of test parameters, casting strains, concrete and steel properties, and graphs of the applied load vs. Mid-Span Deflection, End Slip, bottom and top flange strains along the span, crack width along interior support and interior and exterior quarter-point deflection.

Some additional dimensions of the deck and embossments are illustrated below:

Embossment Dimensions:

N_{b-v} : 0.67 in. N_{b-h} : 1.85 in. W_b : 0.68 in. s : 3.36 in.

N_{t-v} : 1.59 in. N_{t-h} : 1.57 in. W_t : 0.25 in. p_h : 0.10 in.

Deck Cross-Section:

D_w : 2.24 in.

B_b : 5.0 in.

B_t : 5.0 in.

C_s : 12 in.

Test Designation: XOREX25-1
Cast Date: 10/16/2000
Test Date: 11/28/2000

Materials and Dimensions

General:

Width: 6 ft (2 panels)
Span length: 10 ft.
Type of Reinforcement: 25 lb/yd³ -1 ½” Xorex Fiber

Deck:

Deck type: 2VLI-20
Design Thickness: 0.0358 in
Height: 2 in
Area: 0.519 in²/ft
Yield Stress: 50 ksi
Ultimate Strength: 60 ksi

Concrete:

Test Strength: 4300 psi
Total Depth: 4.5 in

Results

Maximum Applied Load: 305 psf
Mid-Span Deflection at Maximum Load: 1.05 in
Interior Quarter Point Deflection at Maximum Load: 0.55 in
Exterior Quarter Point Deflection at Maximum Load: 0.64 in
End Slip at Maximum Load: 0.10 in

Strains Due to Fresh Concrete (µε)

1SG1A	1SG1B	1SG2A	1SG2B	1SG3A	1SG3B	1SG4A	1SG4B	1SG5A	1SG5B	1SG6A	1SG6B
209.6	-171.5	404.7	-402.5	508.3	-423.7	461.8	-380.5	262.1	-214.3	-76.7	77.6

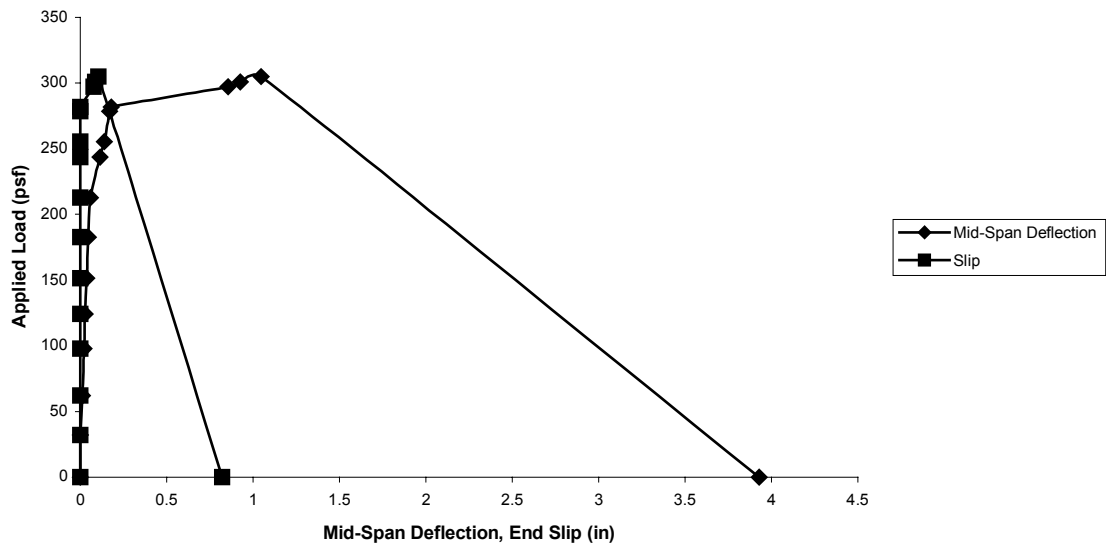

Figure B.1 XOREX25-1 Applied Load vs. Mid-Span Deflection and End Slip

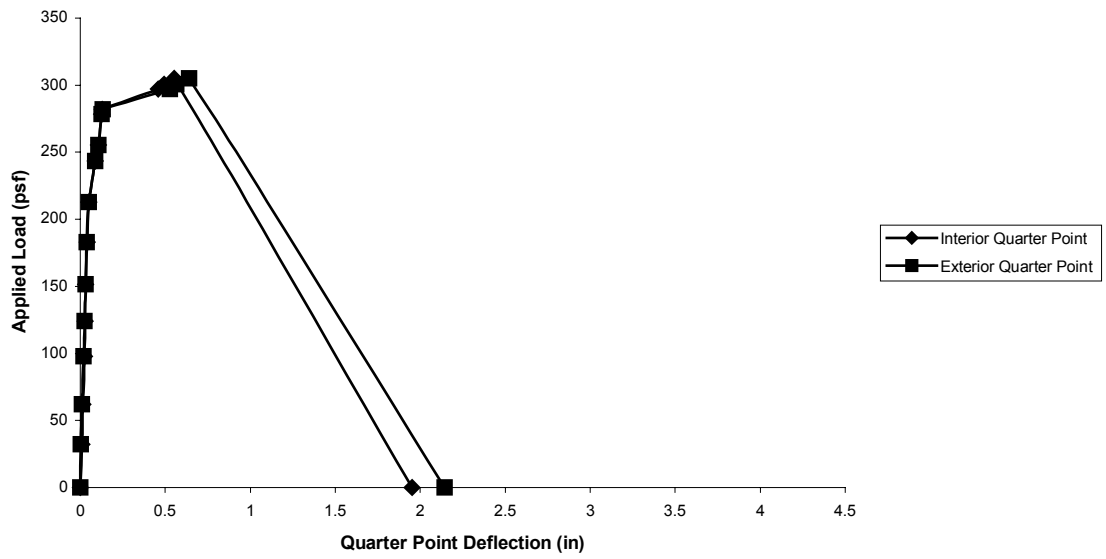

Figure B.2 XOREX25-1 Applied Load vs. Quarter Point Deflection

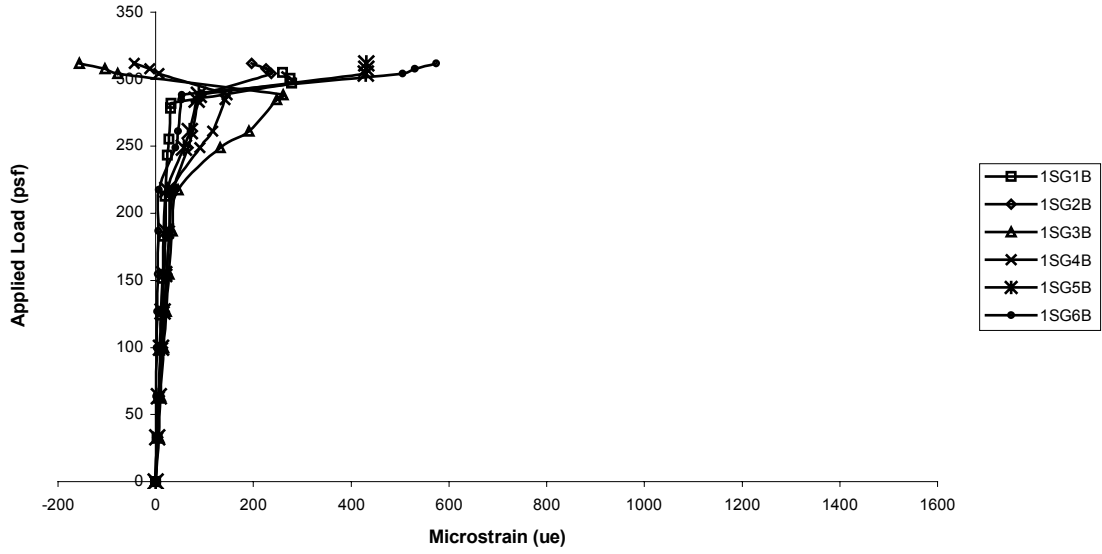

Figure B.3 XOREX25-1 Applied Load vs. Strain in Deck Top Flange along Span

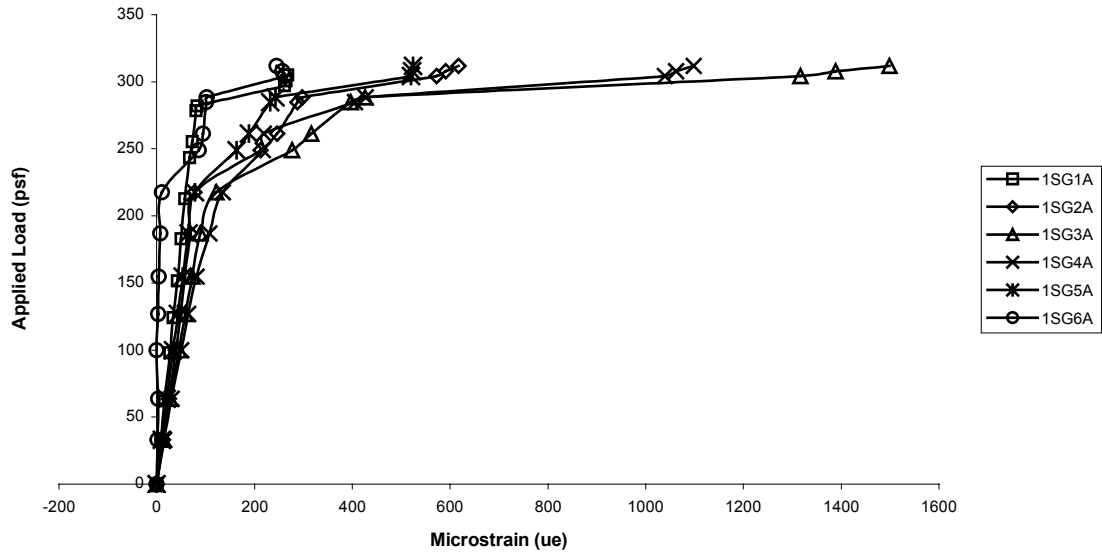

Figure B.4 XOREX25-1 Applied Load vs. Strain in Deck Bottom Flange along Span

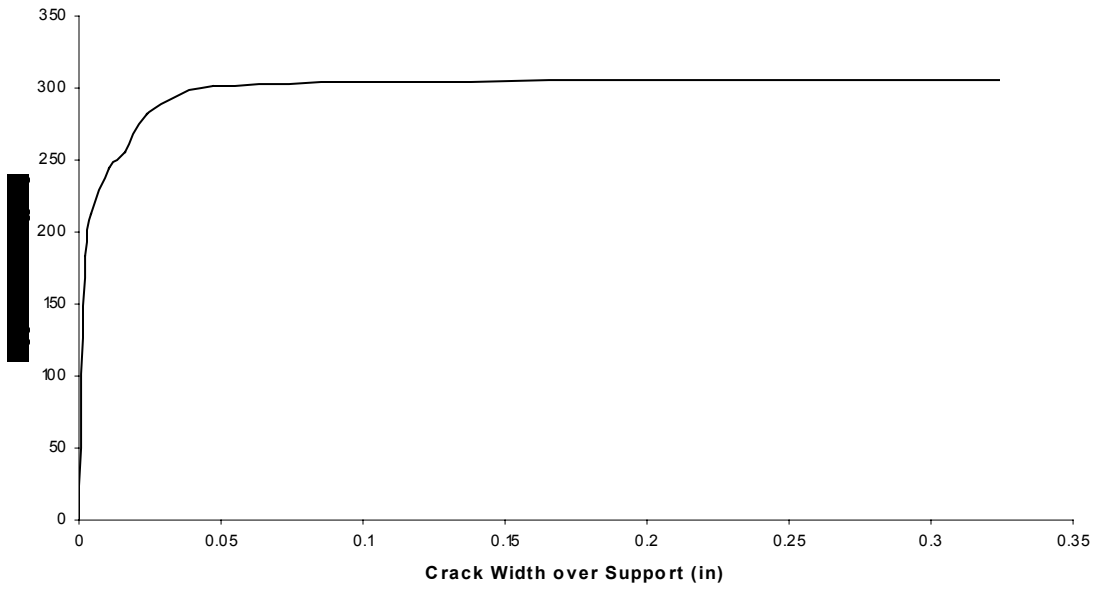

Figure B.5 XOREX25-1 Applied Load vs. Crack Width at Interior Support

Test Designation: XOREX25-2
Cast Date: 10/16/2000
Test Date: 11/28/2000

Materials and Dimensions

General:

Width: 6 ft (2 panels)
Span length: 10 ft.
Intermediate Span Length: 4 ft.
Type of Reinforcement: 25 lb/yd³ -1 ½” Xorex Fiber

Deck:

Deck type: 2VLI-20
Design Thickness: 0.0358 in
Height: 2 in
Area: 0.519 in²/ft
Yield Stress: 50 ksi
Ultimate Strength: 60ksi

Concrete:

Test Strength: 4300 psi
Total Depth: 4.5 in

Results

Maximum Applied Load: 387 psf
Mid-Span Deflection at Maximum Load: 0.76 in
Interior Quarter Point Deflection at Maximum Load: 0.47 in
Exterior Quarter Point Deflection at Maximum Load: 0.47 in
End Slip at Maximum Load: 0.01 in

Strains Due to Fresh Concrete (µε)

2SG1A	2SG1B	2SG2A	2SG2B	2SG3A	2SG3B	2SG4A	2SG4B	2SG5A	2SG5B	2SG6A	2SG6B
202.8	-206.7	532.8	-407.1	502.1	-444.6	451.6	-397.0	N/A	-195.0	-43.7	74.7

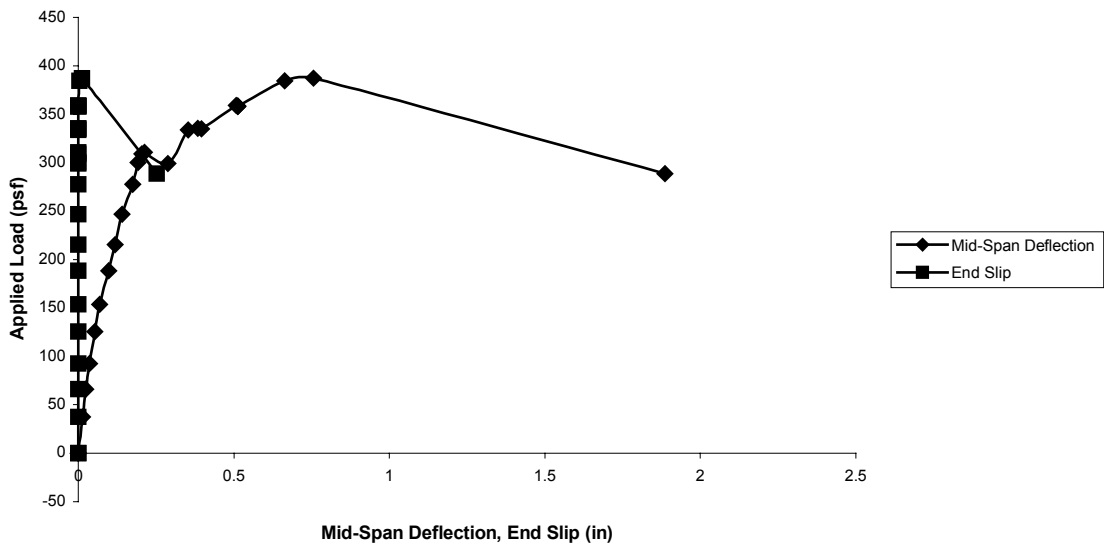

Figure B.6 XOREX25-2 Applied Load vs. Mid-Span Deflection and End Slip

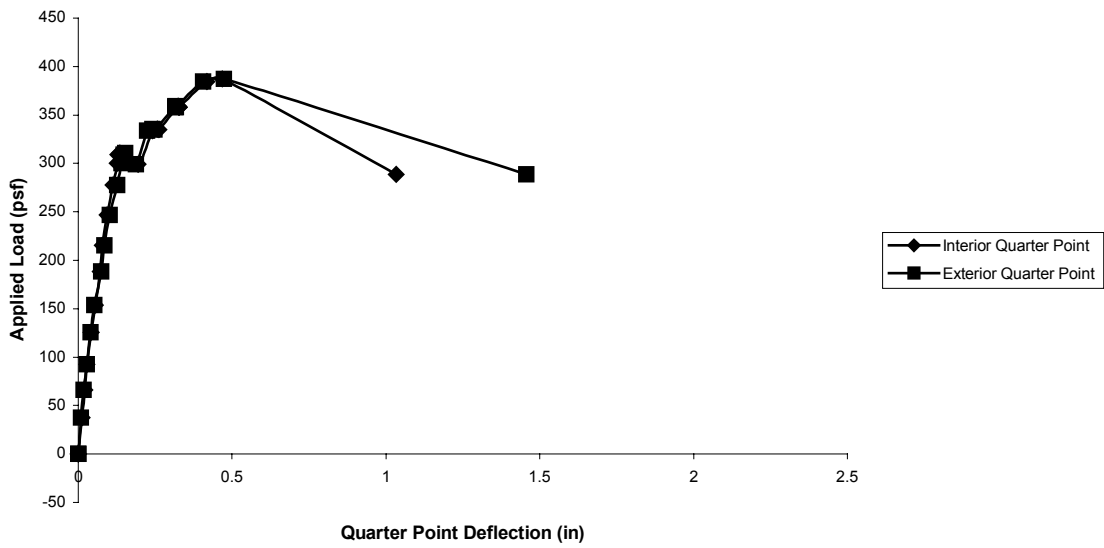

Figure B.7 XOREX25-2 Applied Load vs. Quarter Point Deflection

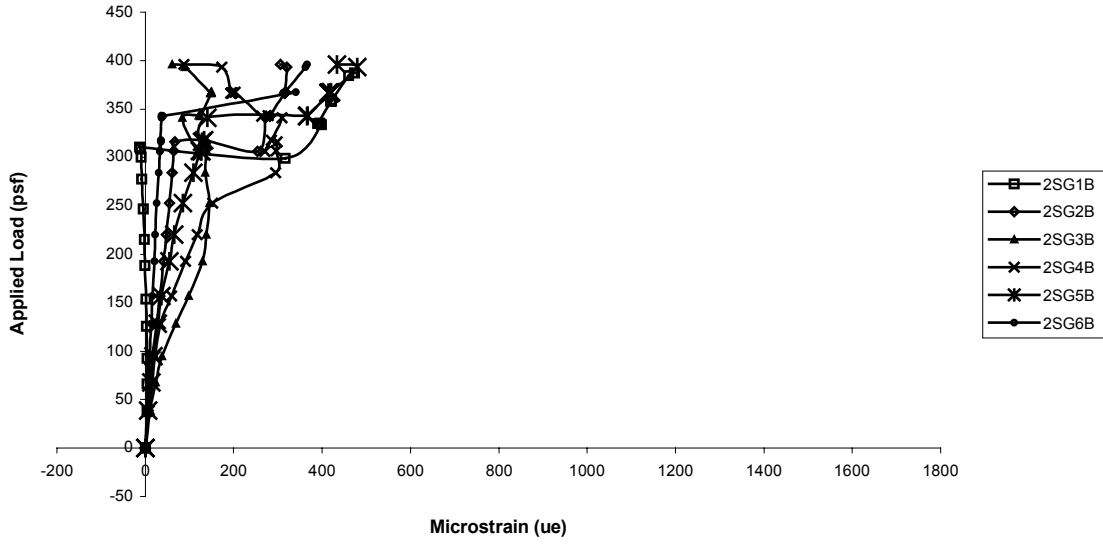

Figure B.8 XOREX25-2 Applied Load vs. Strain in Deck Top Flange along Span

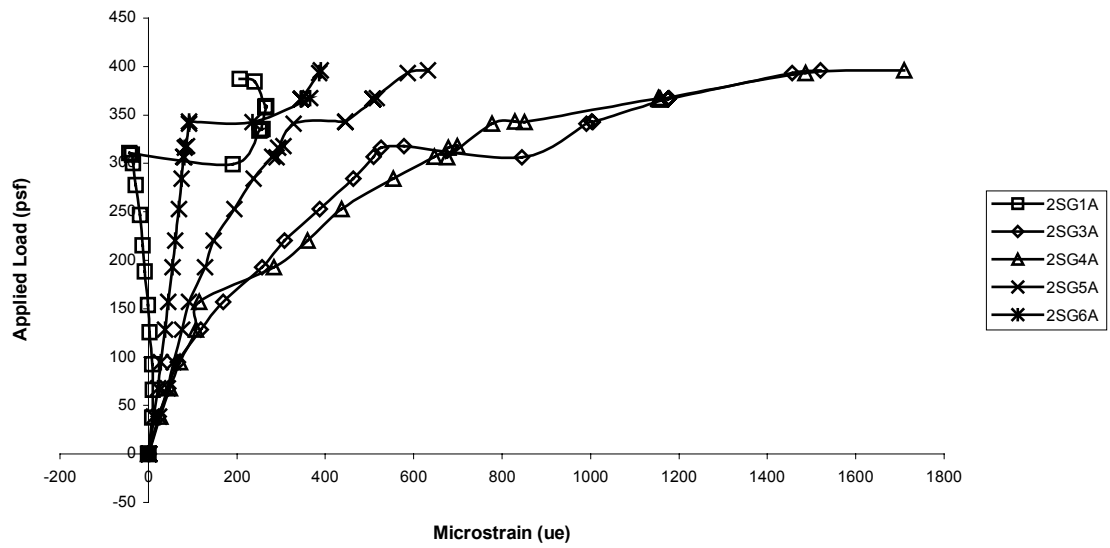

Figure B.9 XOREX25-2 Applied Load vs. Strain in Deck Bottom Flange along Span

APPENDIX C: XOREX-50-COMPOSITE SLABS UNDER DISTRIBUTED LOAD TEST PLOTS

Results from the slabs reinforced with 50 lb/yd³ XOREX steel fibers tested under distributed load are illustrated in the graphs presented in this Appendix. Each set of results includes a summary of test parameters, casting strains, concrete and steel properties, and graphs of the applied load vs. Mid-Span Deflection, End Slip, bottom and top flange strains along the span, crack width along interior support and interior and exterior quarter-point deflection.

Some additional dimensions of the deck and embossments are illustrated below:

Embossment Dimensions:

N_{b-v} : 0.67 in. N_{b-h} : 1.85 in. W_b : 0.68 in. s : 3.36 in.

N_{t-v} : 1.59 in. N_{t-h} : 1.57 in. W_t : 0.25 in. p_h : 0.10 in.

Deck Cross-Section:

D_w : 2.24 in.

B_b : 5.0 in.

B_t : 5.0 in.

C_s : 12 in.

Test Designation: XOREX50-1
Cast Date: 12/07/2000
Test Date: 01/10/2001

Materials and Dimensions

General:

Width: 6 ft (2 panels)
Span length: 10 ft.
Intermediate Span Length: 4 ft.
Type of Reinforcement: 50 lb/yd³ -1 ½” Xorex Fiber

Deck:

Deck type: 2VLI-20
Design Thickness: 0.0358 in
Height: 2 in
Area: 0.519 in²/ft
Yield Stress: 50 ksi
Ultimate Strength: 60 ksi

Concrete:

Test Strength: 5800 psi
Total Depth: 4.5 in

Results

Maximum Applied Load: 417 psf
Mid-Span Deflection at Maximum Load: 0.48 in
Interior Quarter Point Deflection at Maximum Load: 0.27 in
Exterior Quarter Point Deflection at Maximum Load: 0.28 in
End Slip at Maximum Load: 0.0004 in

Strains Due to Fresh Concrete (µε)

1SG1A	1SG1B	1SG2A	1SG2B	1SG3A	1SG3B	1SG4A	1SG4B	1SG5A	1SG5B	1SG6A	1SG6B
167.7	-226.4	420.0	-415.2	512.6	-510.3	486.8	-444.7	280.0	-242.1	-35.8	62.9

Steel Deck Strain Gage Locations

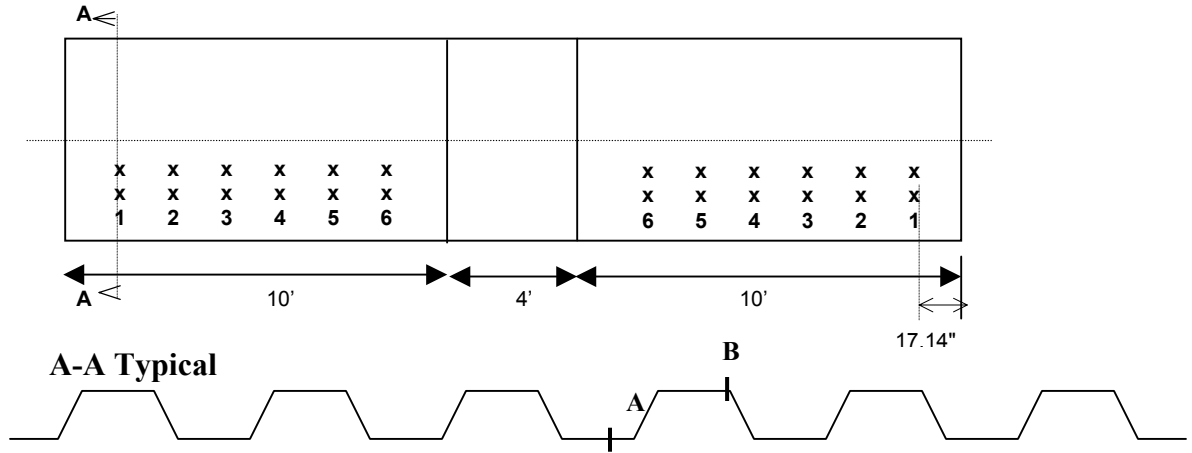

Potentiometer and Wire Pot Locations (Top View)

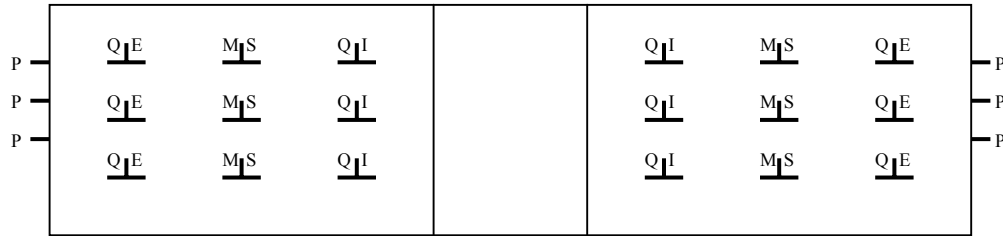

- P — Potentiometer
- Q1E Exterior Quarter Point Wire Pot
- M1S Mid-Span Wire Pot
- Q1I Interior Quarter Point Wire Pot

Potentiometer Locations at Each Side of Slab (Side View)

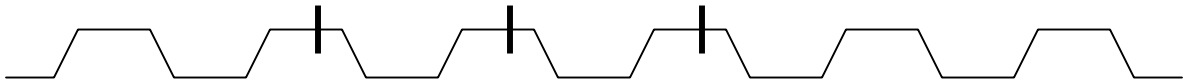

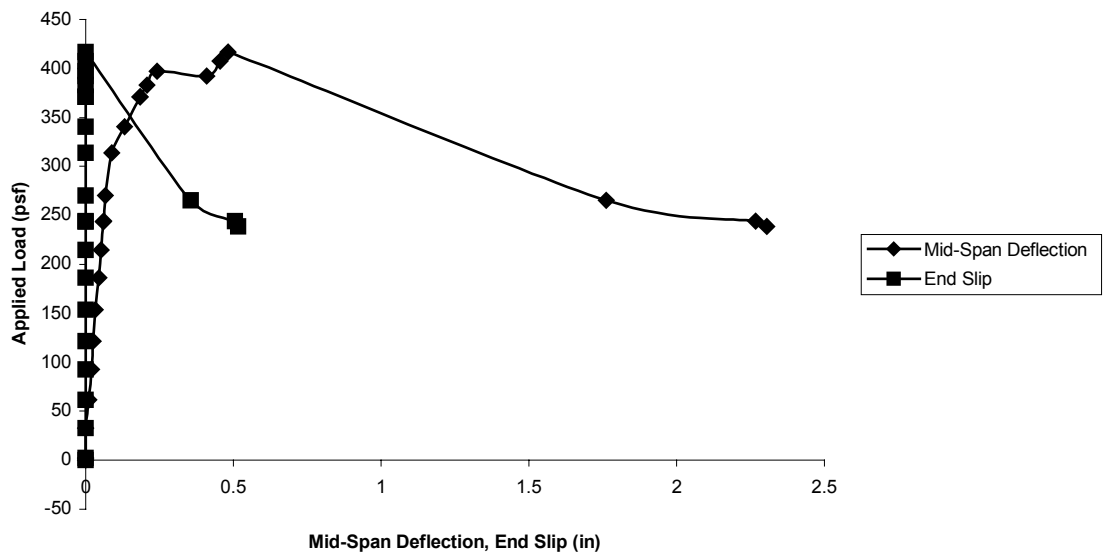

Figure C.1 XOREX50-1 Applied Load vs. Mid-Span Deflection and End Slip

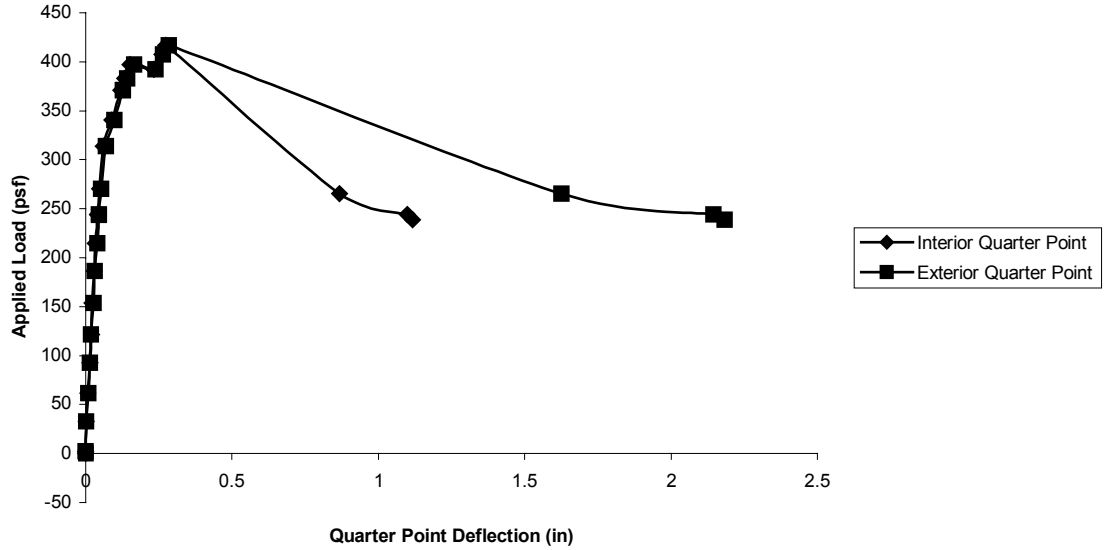

Figure C.2 XOREX50-1 Applied Load vs. Quarter Point Deflection

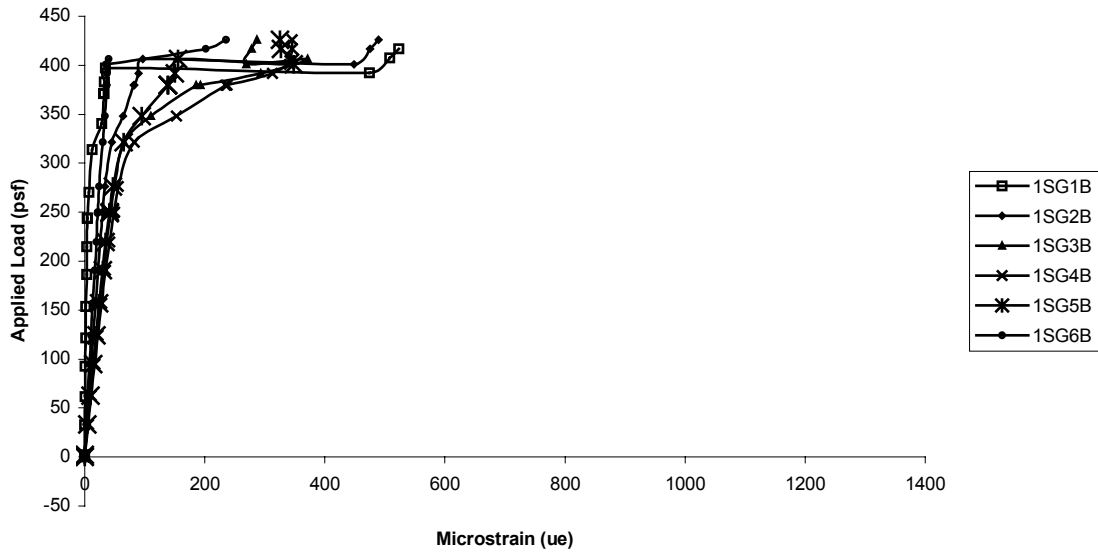

Figure C.3 XOREX50-1 Applied Load vs. Strain in Deck Top Flange along Span

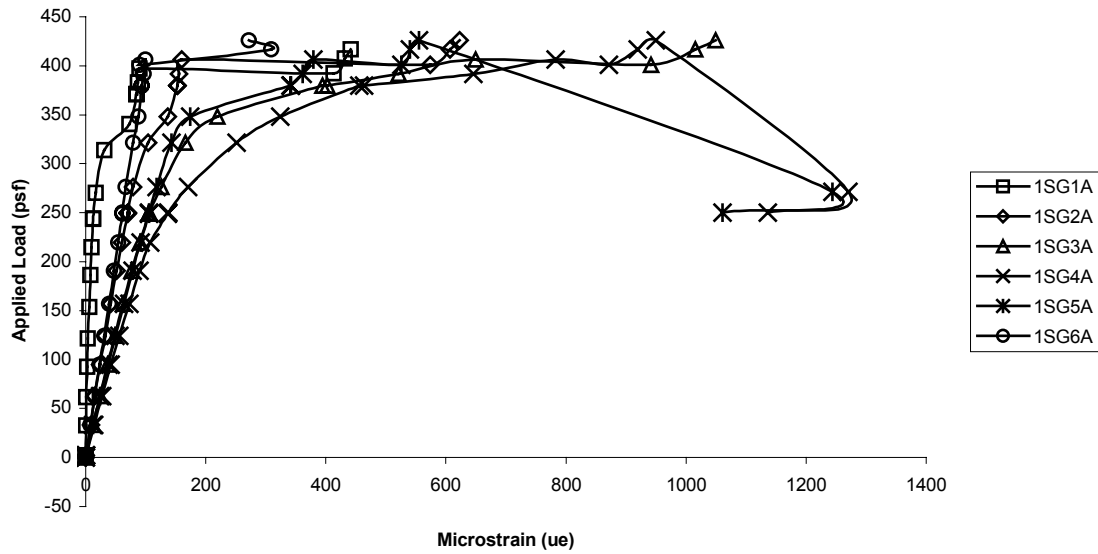

Figure C.4 XOREX50-1 Applied Load vs. Strain in Deck Bottom Flange along Span

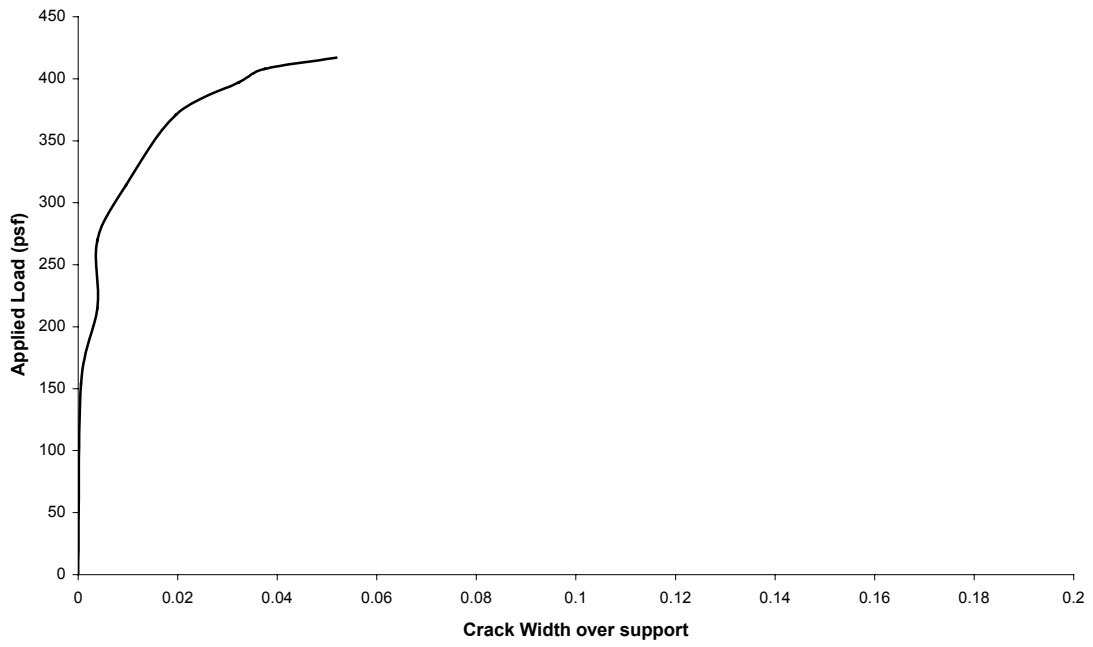

Figure C.5 XOREX50-1 Applied Load vs. Crack Width at Interior Support

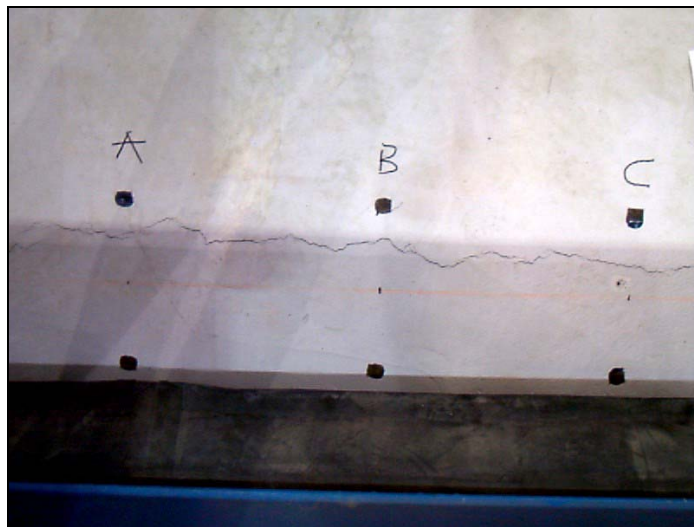

Figure C.6 XOREX50-1 Crack Over Interior Support

Test Designation: XOREX50-2
Cast Date: 12/07/2000
Test Date: 01/10/2001

Materials and Dimensions

General:

Width: 6 ft (2 panels)
Span length: 10 ft.
Intermediate Span Length: 4 ft.
Type of Reinforcement: 50 lb/yd³ -1 ½” Xorex Fiber

Deck:

Deck type: 2VLI-20
Design Thickness: 0.0358 in
Height: 2 in
Area: 0.519 in²/ft
Yield Stress: 50 ksi
Ultimate Strength: 60 ksi

Concrete:

Test Strength: 5800 psi
Total Depth: 4.5 in

Results

Maximum Applied Load: 489 psf
Mid-Span Deflection at Maximum Load: 1.51 in
Interior Quarter Point Deflection at Maximum Load: 0.80 in
Exterior Quarter Point Deflection at Maximum Load: 1.07 in
End Slip at Maximum Load: 0.15 in

Strains Due to Fresh Concrete (µε)

2SG1A	2SG1B	2SG2A	2SG2B	2SG3A	2SG3B	2SG4A	2SG4B	2SG5A	2SG5B	2SG6A	2SG6B
N/A	-236.6	434.4	-433.1	522.7	-493.5	448.4	-428.8	7225.2	-233.2	-63.0	61.1

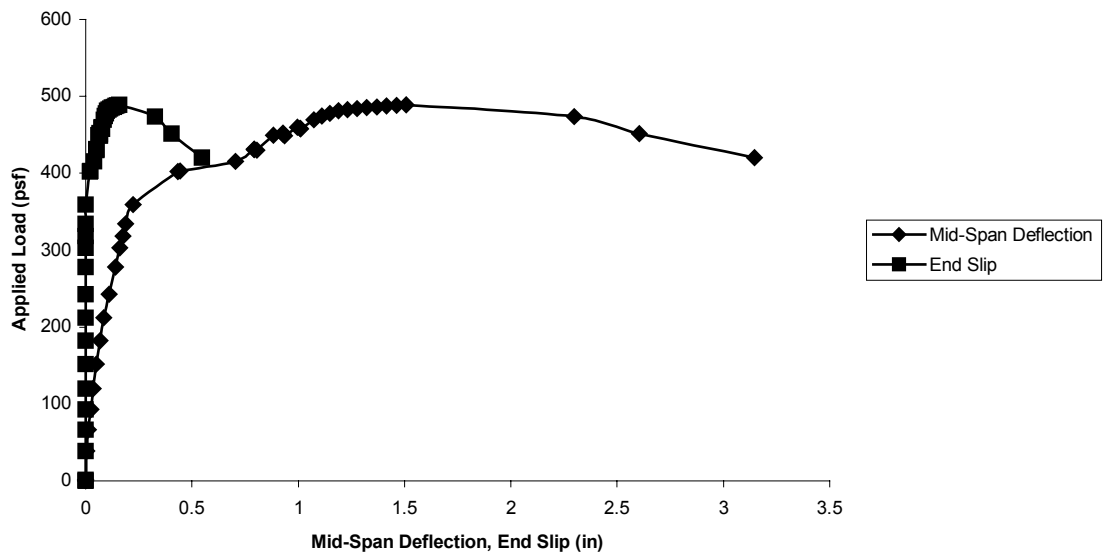

Figure C.6 XOREX50-2 Applied Load vs. Mid-Span Deflection and End Slip

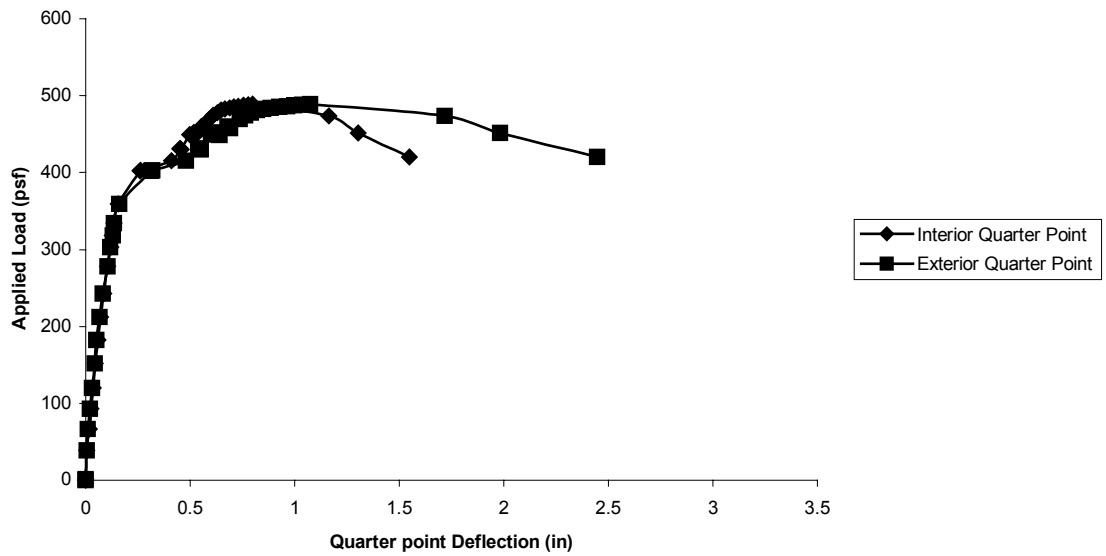

Figure C.7 XOREX50-2 Applied Load vs. Quarter Point Deflection

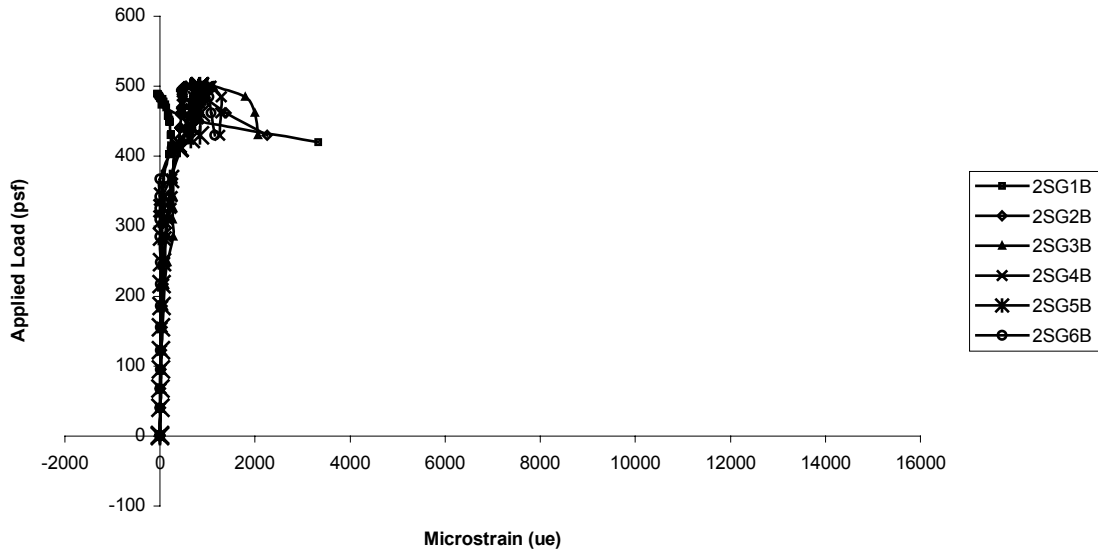

Figure C.8 XOREX50-2 Applied Load vs. Strain in Deck Top Flange along Span

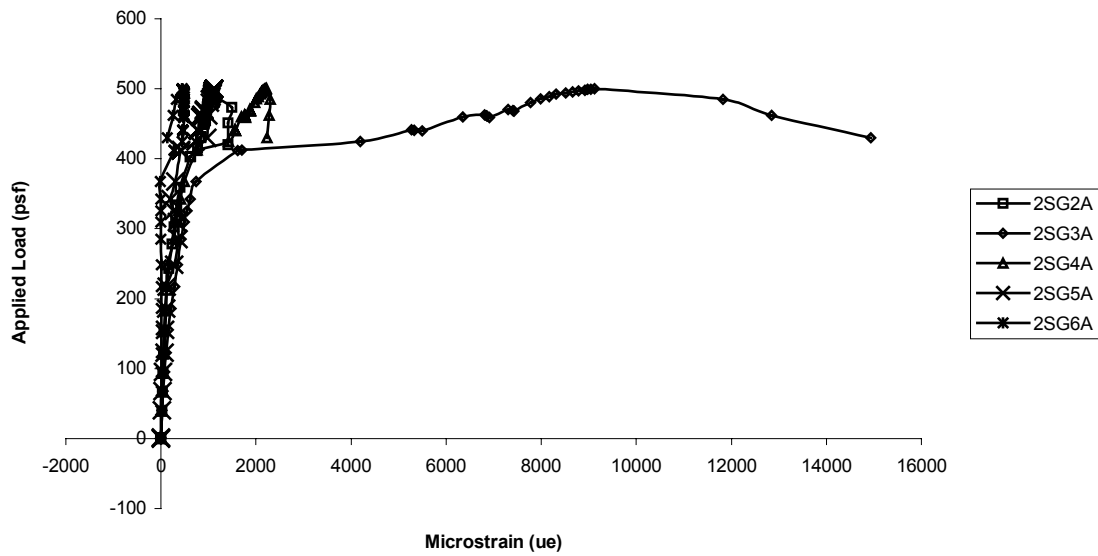

Figure C.9 XOREX50-2 Applied Load vs. Strain in Deck Bottom Flange along Span

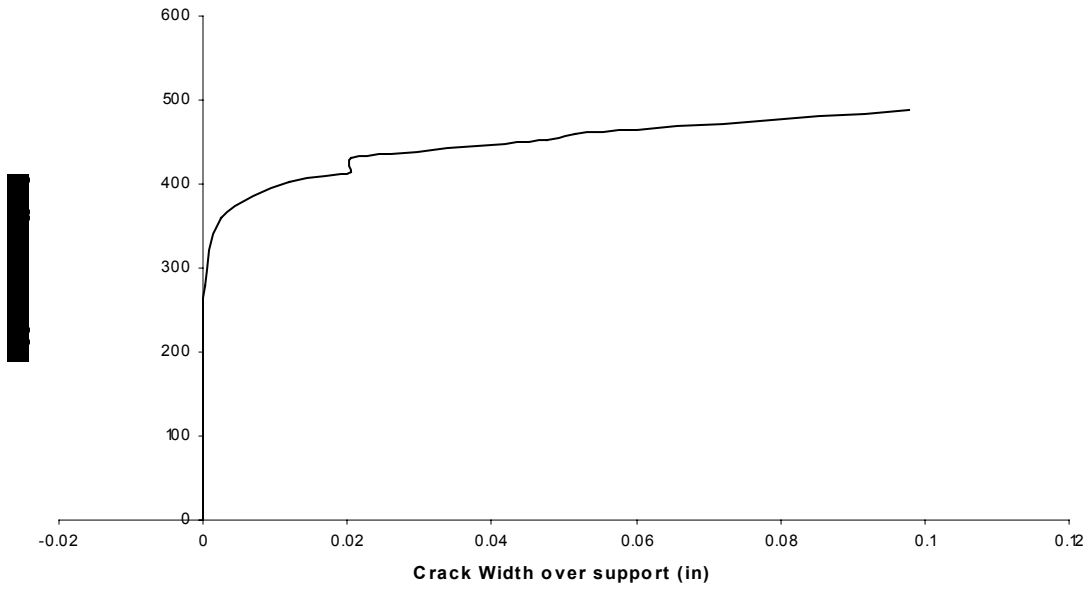

Figure C.10 XOREX50-2 Applied Load vs. Crack Width at Interior Support



Figure C.12 XOREX 50-2 Crack Over Interior Support

APPENDIX D: Microfiber-MD-COMPOSITE SLABS UNDER DISTRIBUTED LOAD TEST PLOTS

Results from the slabs reinforced with 1.5 lb/yd³ of Microfiber-MD synthetic fibers tested under distributed load are illustrated in the graphs presented in this Appendix. Each set of results includes a summary of test parameters, casting strains, concrete and steel properties, and graphs of the applied load vs. Mid-Span Deflection, End Slip, bottom and top flange strains along the span, crack width along interior support and interior and exterior quarter-point deflection.

Some additional dimensions of the deck and embossments are illustrated below:

Embossment Dimensions:

N_{b-v} : 0.67 in. N_{b-h} : 1.85 in. W_b : 0.68 in. s : 3.36 in.

N_{t-v} : 1.59 in. N_{t-h} : 1.57 in. W_t : 0.25 in. p_h : 0.10 in.

Deck Cross-Section:

D_w : 2.24 in.

B_b : 5.0 in.

B_t : 5.0 in.

C_s : 12 in.

Test Designation: MicrofiberMD-1
Cast Date: 12/07/2000
Test Date: 01/11/2001

Materials and Dimensions

General:

Width: 6 ft (2 panels)
Span length: 10 ft.
Intermediate Span Length: 4 ft.
Type of Reinforcement: 1.5 lb/yd³ –MicrofiberMD

Deck:

Deck type: 2VLI-20
Design Thickness: 0.0358 in
Height: 2 in
Area: 0.519 in²/ft
Yield Stress: 50 ksi
Ultimate Strength: 60 ksi

Concrete:

Test Strength: 4100 psi
Total Depth: 4.5 in

Results

Maximum Applied Load: 372 psf
Mid-Span Deflection at Maximum Load: 4.85 in
Interior Quarter Point Deflection at Maximum Load: 2.27 in
Exterior Quarter Point Deflection at Maximum Load: 3.30 in
End Slip at Maximum Load: 0.92 in

Strains Due to Fresh Concrete (µε)

1SG1A	1SG1B	1SG2A	1SG2B	1SG3A	1SG3B	1SG4A	1SG4B	1SG5A	1SG5B	1SG6A	1SG6B
181.0	-60.2	406.7	-391.9	469.0	-454.9	389.5	-361.0	175.8	-191.9	-149.1	104.7

Steel Deck Strain Gage Locations

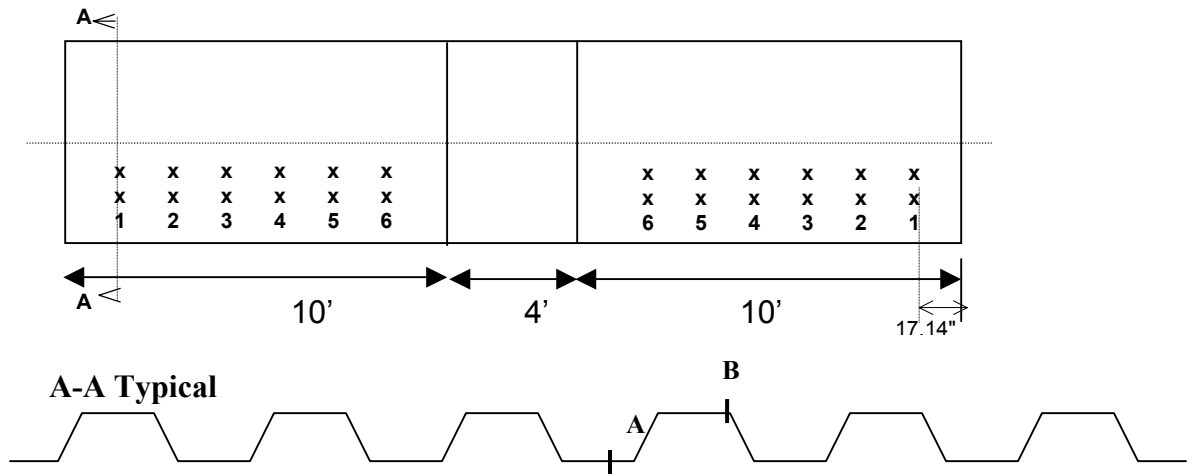

Potentiometer and Wire Pot Locations (Top View)

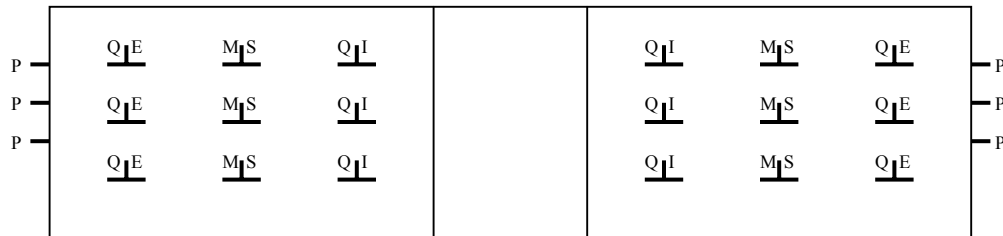

- P — Potentiometer
- Q1E Exterior Quarter Point Wire Pot
- M1S Mid-Span Wire Pot
- Q1I Interior Quarter Point Wire Pot

Potentiometer Locations at Each Side of Slab (End View)

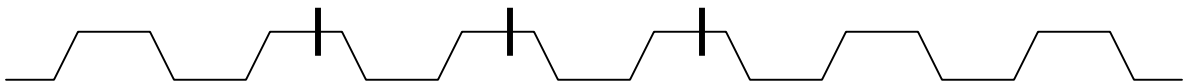

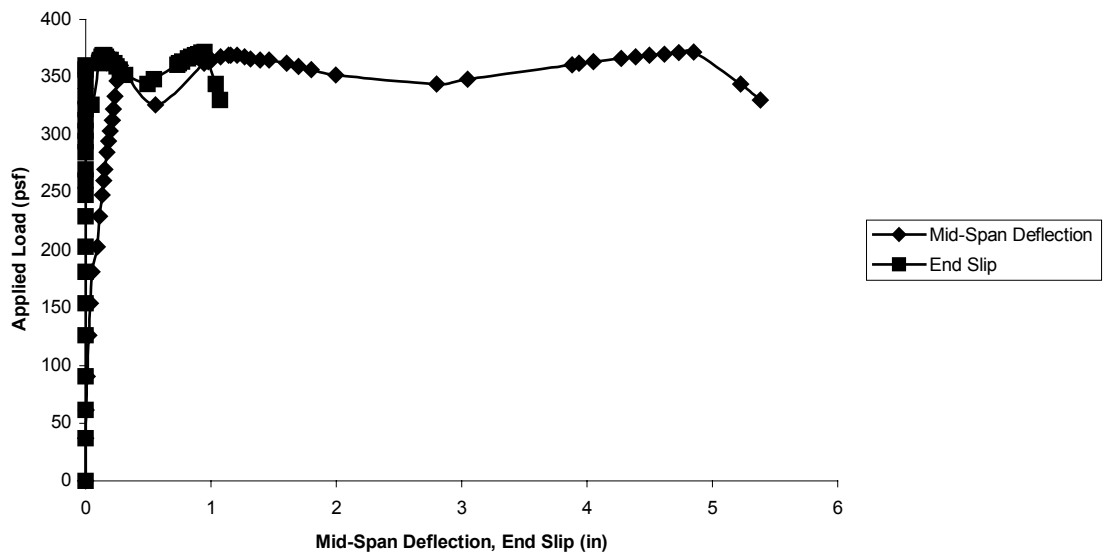

Figure D.1 MicrofiberMD-1 Applied Load vs. Mid-Span Deflection and End Slip

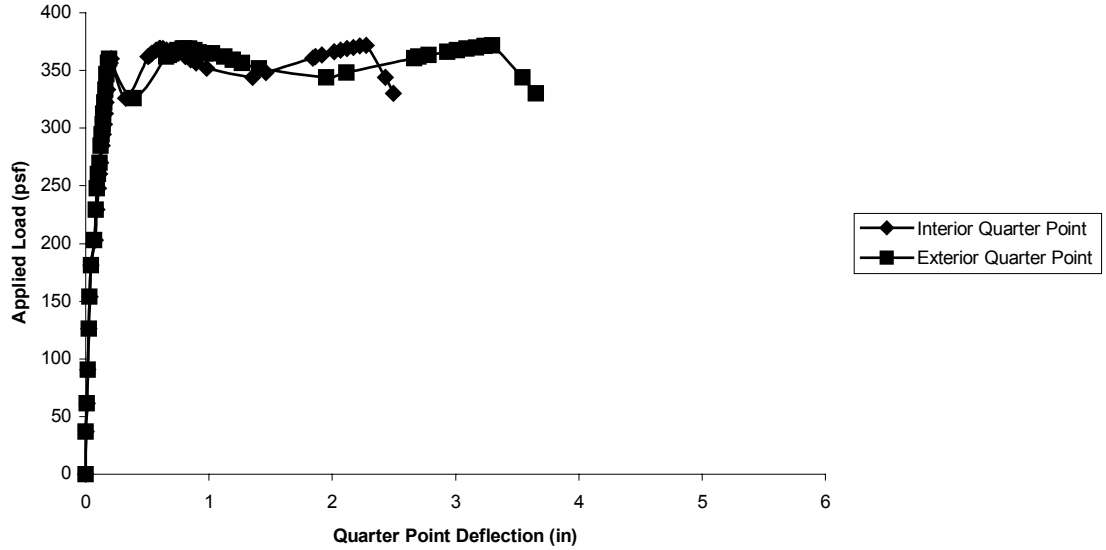

Figure D.2 MicrofiberMD-1 Applied Load vs. Quarter Point Deflection

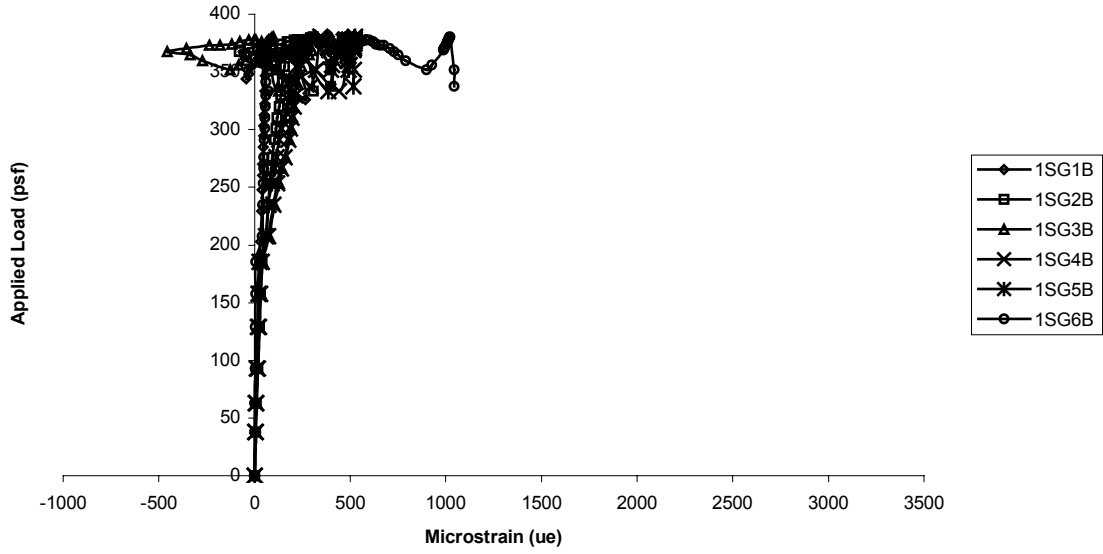

Figure D.3 MicrofiberMD-1 Applied Load vs. Strain in Deck Top Flange along Span

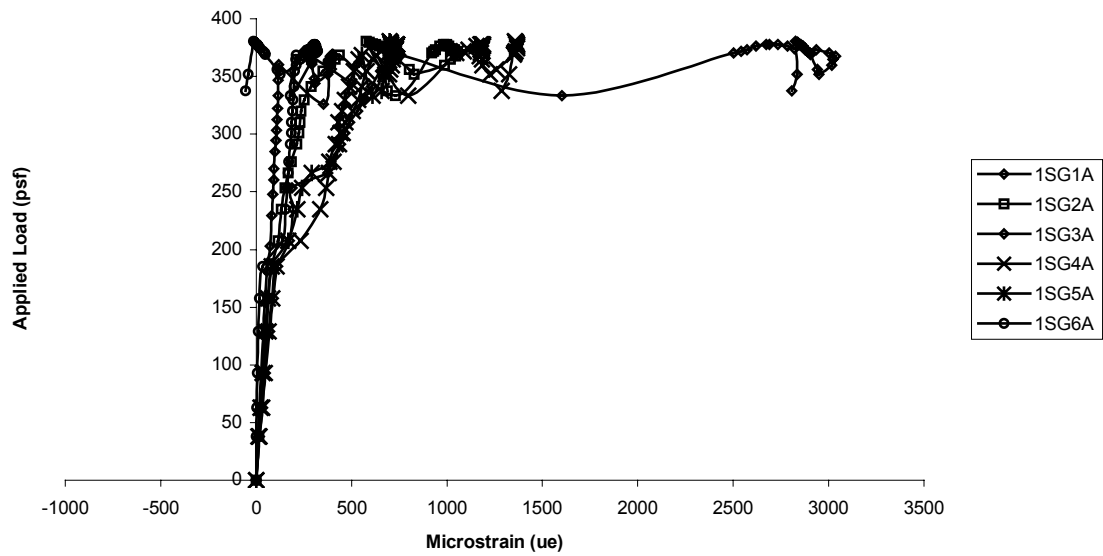

Figure D.4 MicrofiberMD-1 Applied Load vs. Strain in Deck Bottom Flange along Span

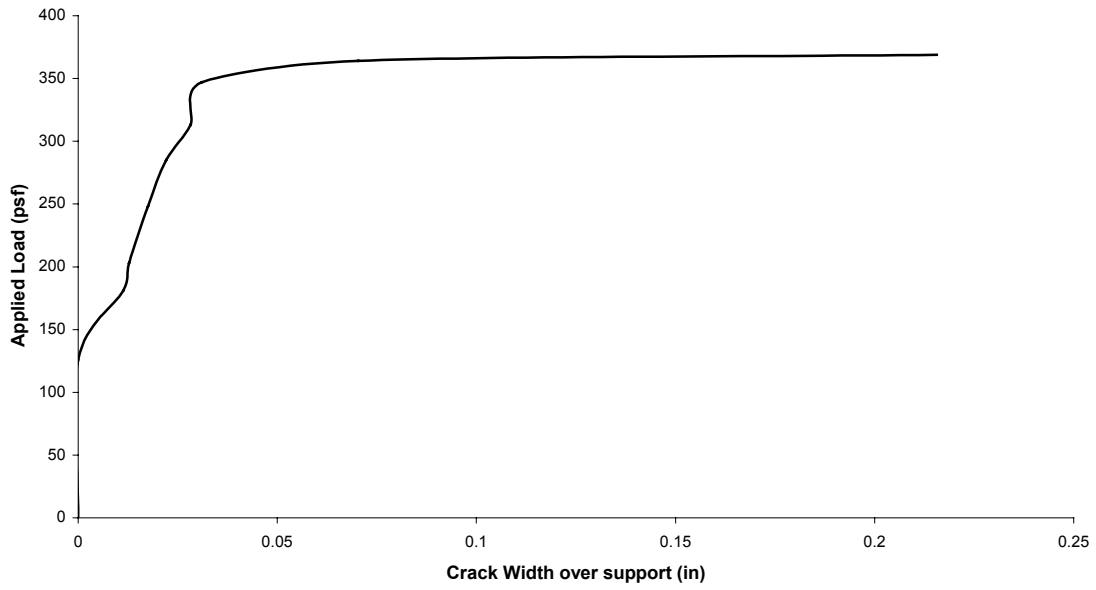

Figure D.5 MicrofiberMD-1 Applied Load vs. Crack Width at Interior Support

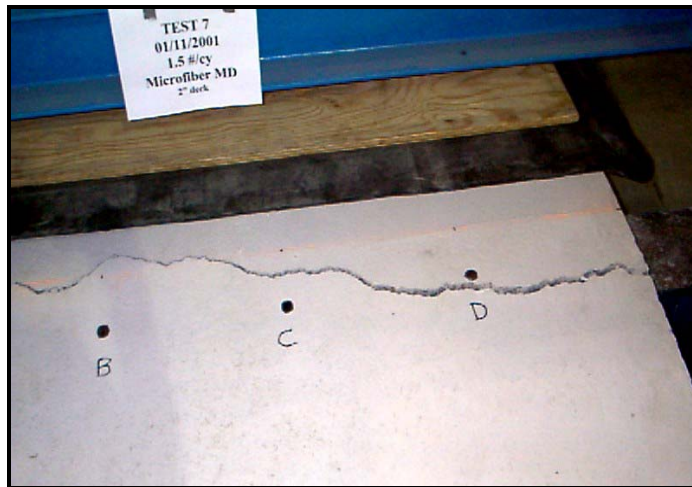

Figure D.6 MicrofiberMD-2 Crack Over Interior Support

Test Designation: MicrofiberMD-2
Cast Date: 12/07/2000
Test Date: 01/11/2001

Materials and Dimensions

General:

Width: 6 ft (2 panels)
Span length: 10 ft.
Intermediate Span Length: 4 ft.
Type of Reinforcement: 50 lb/yd³ -1 ½" Xorex Fiber

Deck:

Deck type: 2VLI-20
Design Thickness: 0.0358 in
Height: 2 in
Area: 0.519 in²/ft
Yield Stress: 50 ksi
Ultimate Strength: 60 ksi

Concrete:

Test Strength: 4100 psi
Total Depth: 4.5 in

Results

Maximum Applied Load: 361 psf
Mid-Span Deflection at Maximum Load: 0.64 in
Interior Quarter Point Deflection at Maximum Load: 0.38 in
Exterior Quarter Point Deflection at Maximum Load: 0.59 in
End Slip at Maximum Load: 0.08 in

Strains Due to Fresh Concrete (µε)

2SG1A	2SG1B	2SG2A	2SG2B	2SG3A	2SG3B	2SG4A	2SG4B	2SG5A	2SG5B	2SG6A	2SG6B
159.0	-202.4	379.9	-378.5	461.3	-437.6	394.2	-387.4	179.6	-201.8	-114.4	105.6

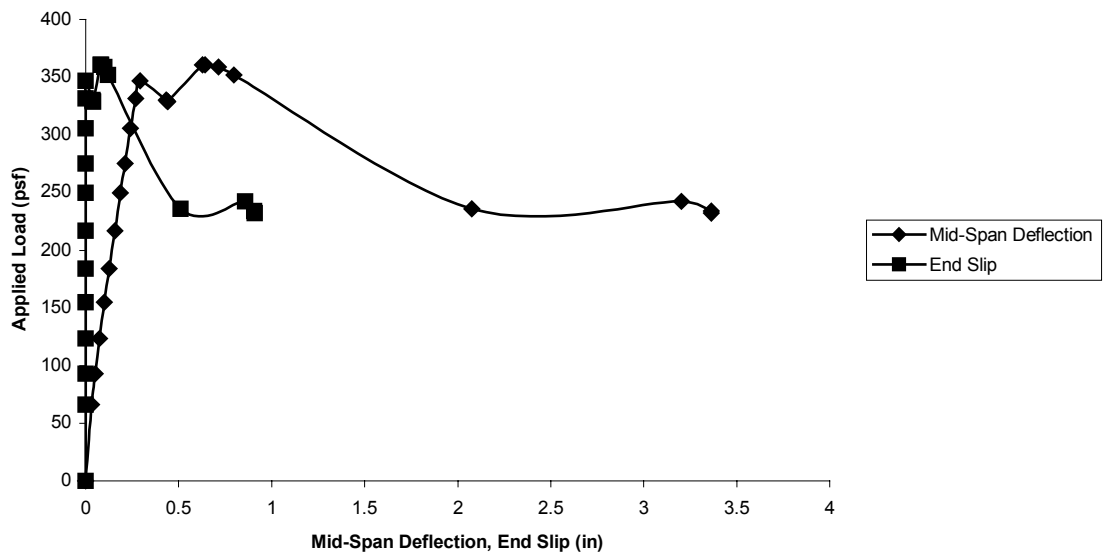

Figure D.6 MicrofiberMD-2 Applied Load vs. Mid-Span Deflection and End Slip

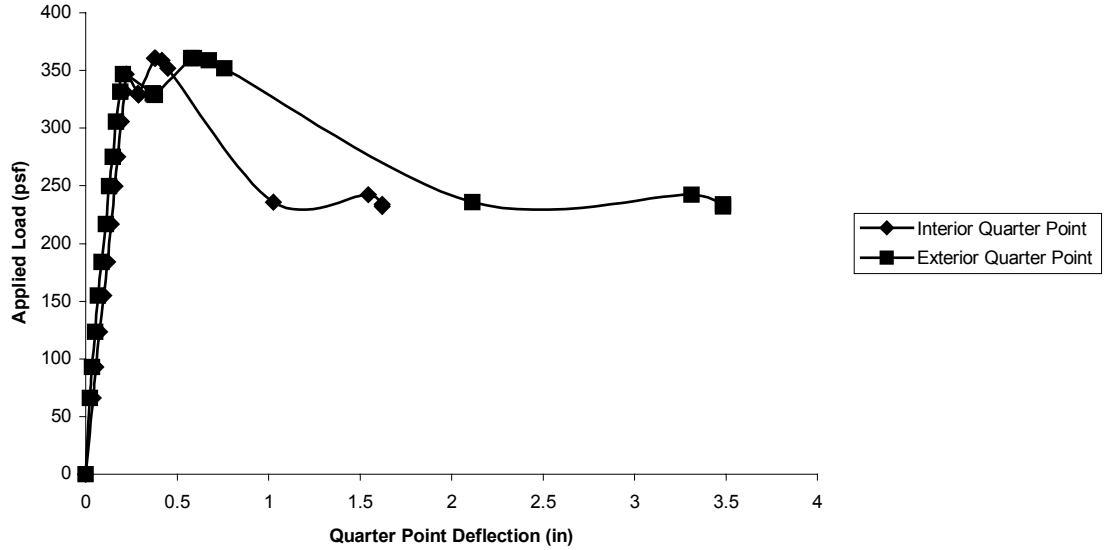

Figure D.7 MicrofiberMD -2 Applied Load vs. Quarter Point Deflection

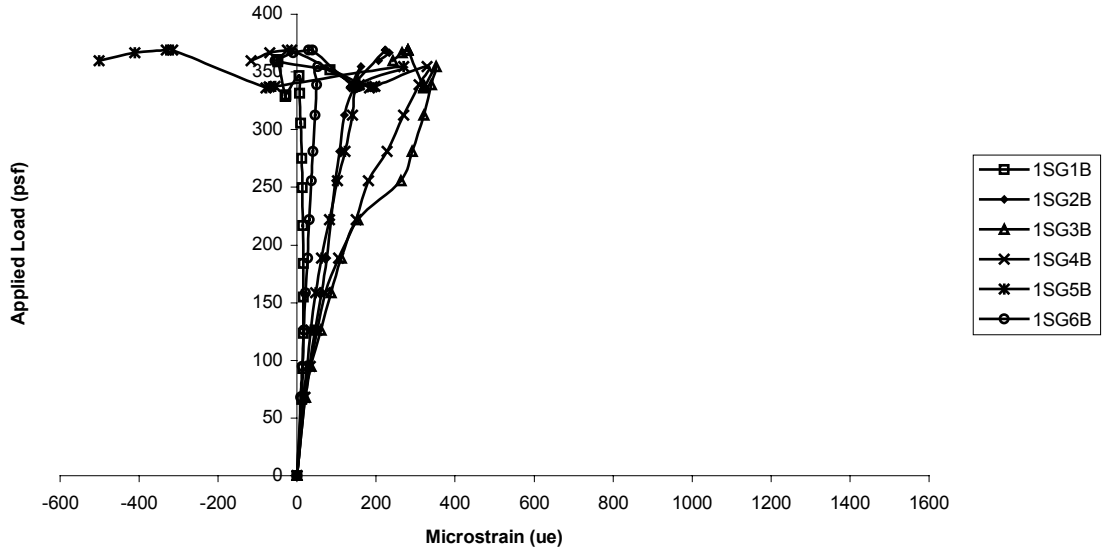

Figure D.8 MicrofiberMD -2 Applied Load vs. Strain in Deck Top Flange along Span

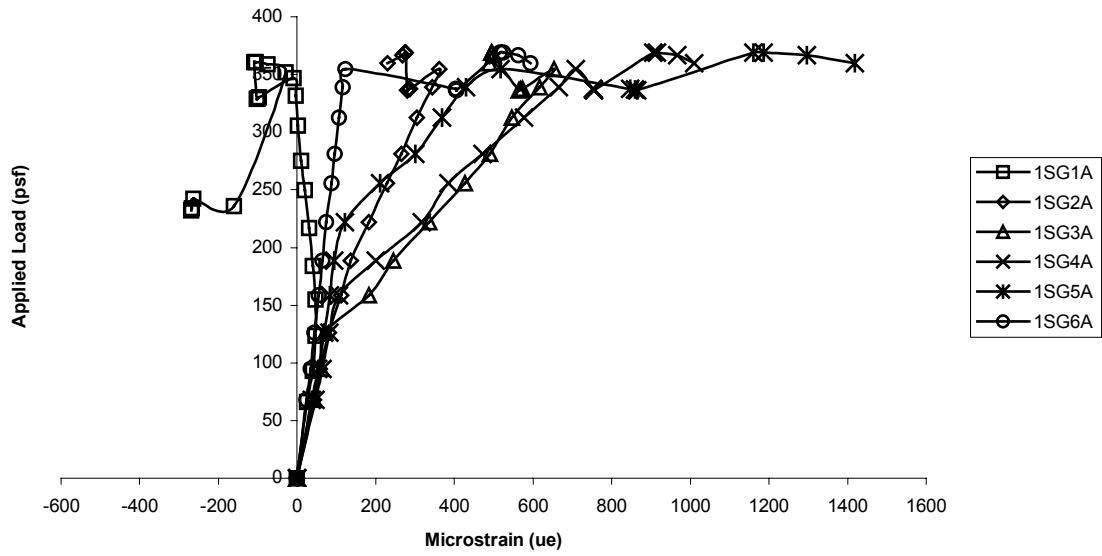

Figure D.9 MicrofiberMD -2 Applied Load vs. Strain in Deck Bottom Flange along Span

APPENDIX E:

ASTM C1018 STANDARD TEST SUMMARY OF RESULTS

The results obtained from the ASTM C1018 Standard Test for “Flexural Toughness and First-Crack Strength of Fiber-Reinforced Concrete” are presented in this Appendix. A set of Results is provided for each fiber mixture and includes general material properties, summary table and a graph of applied load vs. mid-span deflection.

SUMMARY OF RESULTS FOR XOREX-25

GENERAL

Secondary Reinforcement: 25 lb/yd³- 1 1/2" XOREX-Steel Fibers

$f_c = 3000$ psi

$E = 3122$ ksi

Age: 14 days

Table E.1 Summary of Results- XOREX 25

No.	b (in)	d (in)	L (in)	I (in ⁴)	δ_{theo}	P (kips)	δ (in)	Crack Location	R (psi)	I ₅	I ₁₀	I ₂₀
1	3.94	3.97	12	20.53	0.0021	3.570	0.0090	6.75	690.32	3.71	6.14	9.46
2	3.94	4.00	12	21.00	0.0023	3.850	0.0058	6.25	733.33	N/A	N/A	N/A
3	3.94	3.94	12	20.03	0.0019	3.180	0.0047	5.13	625.10	5.06	6.77	10.21
4	3.94	3.94	12	20.03	0.0017	2.830	0.0052	6.00	556.30	3.40	5.18	7.80
5	3.94	4.00	12	21.00	0.0021	3.570	0.0050	6.25	680.00	3.87	6.28	7.27
Avg	3.94	3.97	12	20.52	0.0020	3.400	0.00594	6.075	657.01	4.110	6.077	8.427
σ	0	0.031	0	0.4846	0.00020	0.3980	0.00176	0.5969	68.237	0.856	0.814	1.567

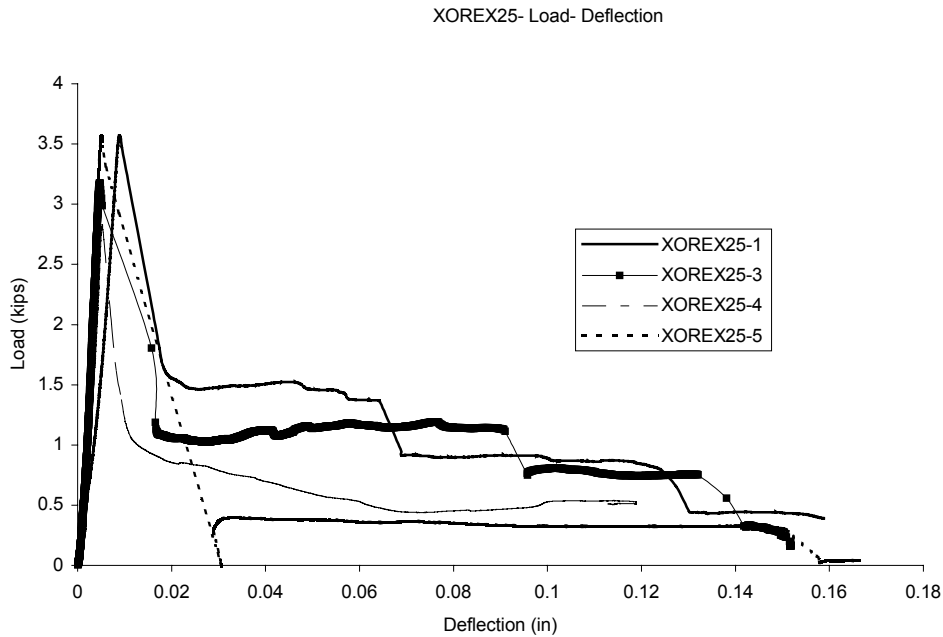

Figure E.1- XOREX25-Load vs. Deflection at 14 days

SUMMARY OF RESULTS FOR XOREX-50

GENERAL:

Secondary Reinforcement: 50 lb/yd³- 1 ½" XOREX-Steel Fibers

$f_c = 3000$ psi

$E = 3122$ ksi

Age: 14 days

Table E.2 Summary of Results- XOREX-50 at 14 days

No.	b (in)	d (in)	L (in)	I (in ⁴)	δ_{theo}	P (kips)	δ (in)	Crack Location	R (psi)	l_5	l_{10}	l_{20}
1	3.94	3.97	12	20.53	0.0019	3.150		6.00	609.10			
2	3.94	3.94	12	20.03	0.0018	3.000	0.0058	6.88	589.71	3.92	6.73	11.63
3	3.94	3.94	12	20.03	0.0021	3.420	0.0051	6.50	672.27	3.49	5.62	9.12
4	3.94	4.00	12	21.00	0.0019	3.230	0.0041	6.00	615.24	4.05	6.68	11.06
5	3.94	4.00	12	21.00	0.0020	3.340	0.0045	5.50	636.19	4.05	6.91	11.67
Avg	3.94	3.97	12	20.52	0.0019	3.228	0.0049	6.175	624.50	3.878	6.485	10.870
σ	0.000	0.031	0.000	0.485	0.000	0.164	0.001	0.527	31.432	0.266	0.585	1.199

XOREX-50: Load-Deflection

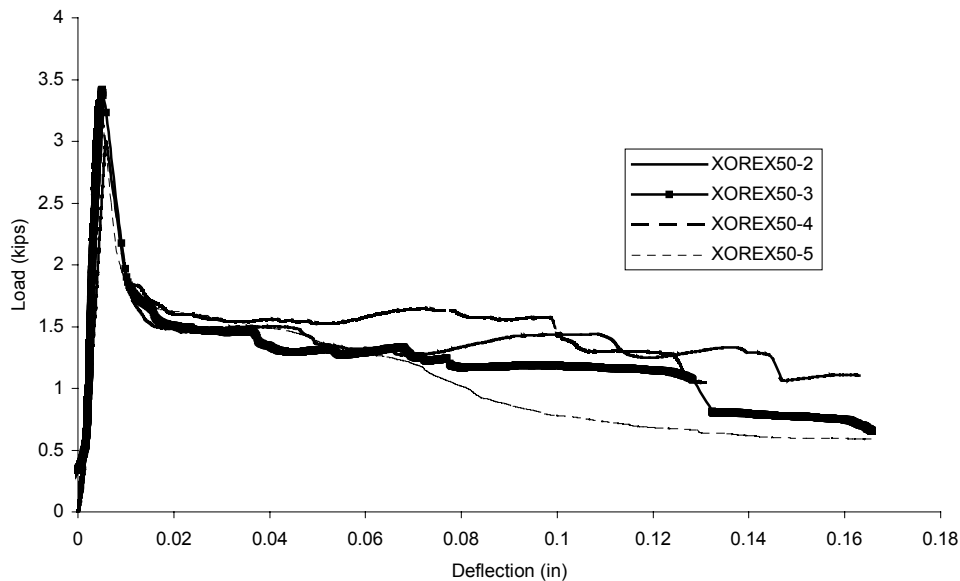

Figure E.2- XOREX50- Load vs. Deflection at 14 days

$f_c = 5800$ psi
 $E = 4344$ ksi
 Age: 45 days

Table E.3 Summary of Results XOREX-50 at 45 days

No.	b (in)	d (in)	L (in)	I (in ⁴)	δ_{theo}	P (kips)	δ (in)	Crack Location	R (psi)	I_5	I_{10}
1	3.94	3.97	12	20.53	0.0021	4.879	0.0060	6.88	943.43	3.91	6.06
2	3.94	3.94	12	20.03	0.0023	5.222	0.0050	5.75	1026.49	4.21	7.78
3	3.94	3.94	12	20.03	0.0022	4.946	0.0060	5.50	972.24	2.63	4.00
4	3.94	4.00	12	21.00	0.0020	4.690	0.0060	6.50	893.33	4.02	6.40
5	3.94	4.00	12	21.00	0.0019	4.620	0.0070	6.94	880.00	4.06	5.60
Avg	3.94	3.97	12	20.52	0.0021	4.871	0.006	6.313	943.10	3.77	5.967
σ	0.000	0.031	0.000	0.485	0.000	0.237	0.001	0.656	59.712	0.644	1.368

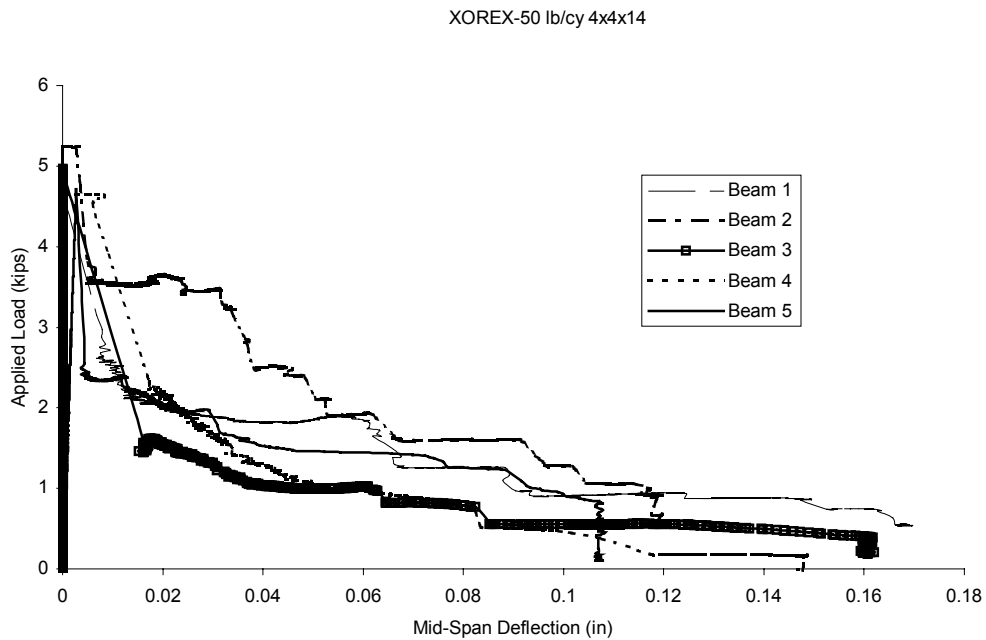

Figure E.3-XOREX-50-Load vs. Deflection at 45 days

SUMMARY OF RESULTS FOR MICROFIBER-MD

GENERAL:

Secondary Reinforcement: 1.5 lb/yd³- Microfiber-MD Synthetic fibers

$f_c = 3000$ psi

$E = 3122$ ksi

Age: 14 days

Table E.4 Summary of Results Microfiber-MD at 14 days

No.	b (in)	δ (in)	L (in)	I (in ⁴)	δ_{theo}	P (kips)	D (in)	Crack Location	R (psi)	l_5	l_{10}	l_{20}
1	3.94	3.94	12	20.03	0.0020	3.246	0.0045	5.75	638.07	4.26	7.40	8.31
2	3.87	3.87	12	18.79	0.0022	3.450	0.0043	6.75	711.52	4.73	5.70	7.15
3	3.94	3.94	12	20.03	0.0021	3.480		5.13	684.07			
4	3.94	3.94	12	20.03	0.0019	3.070	0.0037	5.00	603.47	4.60	5.15	6.60
5	3.94	4.00	12	21.00	0.0022	3.770	0.0044	6.00	718.10	3.62	7.14	8.21
Avg	3.94	3.94	12.000	19.976	0.002	3.403	0.004	5.725	671.044	4.303	6.348	7.568
σ	0.0280	0.0442	0.0000	0.7852	0.0002	0.2638	0.0004	0.7093	49.1798	0.496	1.094	0.832

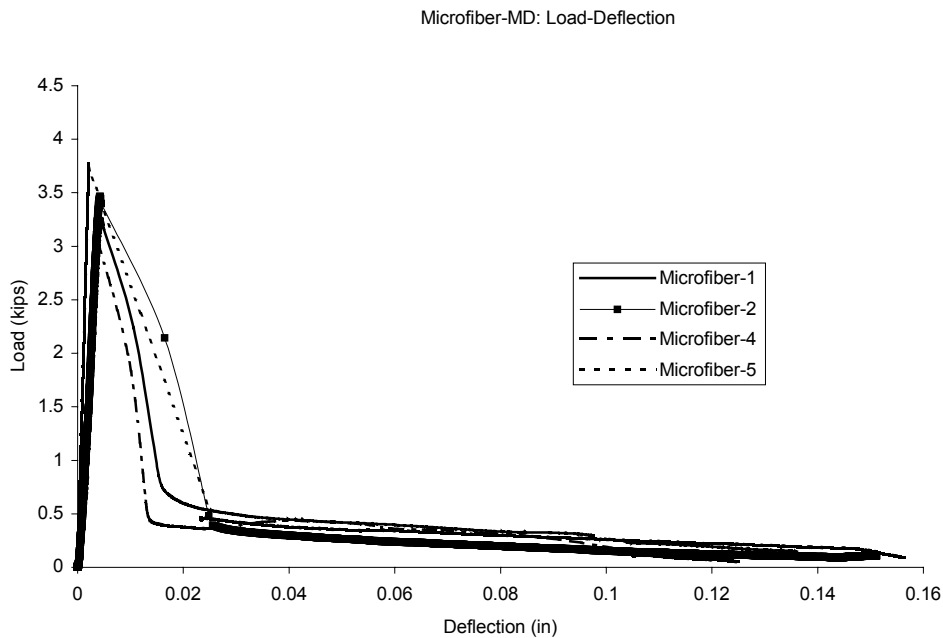

Figure E.4- Microfiber-MD-Load vs. Deflection at 14 days

$f_c = 4000$ psi
 $E = 3640$ ksi
 Age: 45 days

Table E.5 Summary of Results Microfiber-MD at 45 days

No.	b (in)	d (in)	L (in)	I (in ⁴)	δ_{theo}	P (kips)	δ (in)	Crack Location	R (psi)	I_5	I_{10}	I_{20}
1	3.94	3.94	12	20.03	0.0025	4.731		6.88	929.98			
2	3.87	3.87	12	18.79	0.0021	4.478	0.0025	6.00	923.49	4.50	9.06	14.02
3	3.94	3.94	12	20.03	0.0023	5.207		5.81	1023.55			
4	3.94	3.94	12	20.03	0.0019	4.363		5.19	857.64			
5	3.94	4.00	12	21.00	0.0020	4.716	0.0023	6.56	898.29	4.67	8.34	12.38
Avg	3.94	3.94	12	19.98	0.0021	4.699	0.002384	6.0875	926.59	4.59	8.6975	13.2

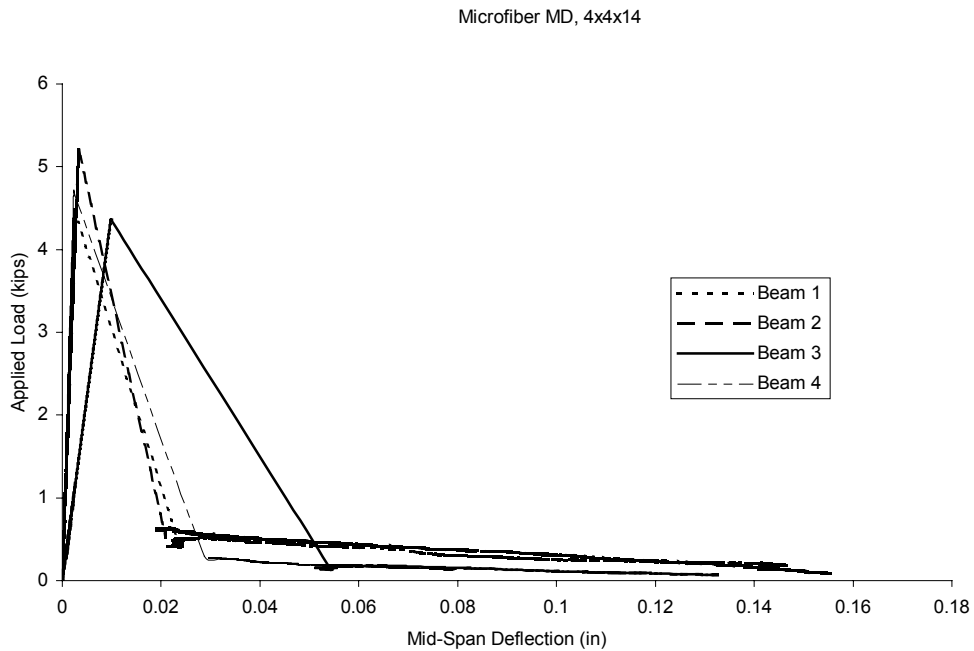

Figure E.5-Microfiber-MD- Load vs. Deflection at 45 days

APPENDIX F

COMPOSITE SLABS UNDER NON-DISTRIBUTED LOADS TEST DATA

The data from the tests on composite slabs under non-distributed loads are presented in this Appendix. Given that a total of forty-one tests were performed only the data will be presented in table format. Each individual tests data is presented in a single table where the strains and deflections at mid-span and quarter-points are presented at every load increment. Refer to figures 5.3-A-K for the load locations.

The figure bellow illustrated the locations of the strain gages and displacement transducers across mid-span and at each quarter point. Strain Gages are numbered one through six from left to right. Displacement Transducers are numbered zero through five from left to right.

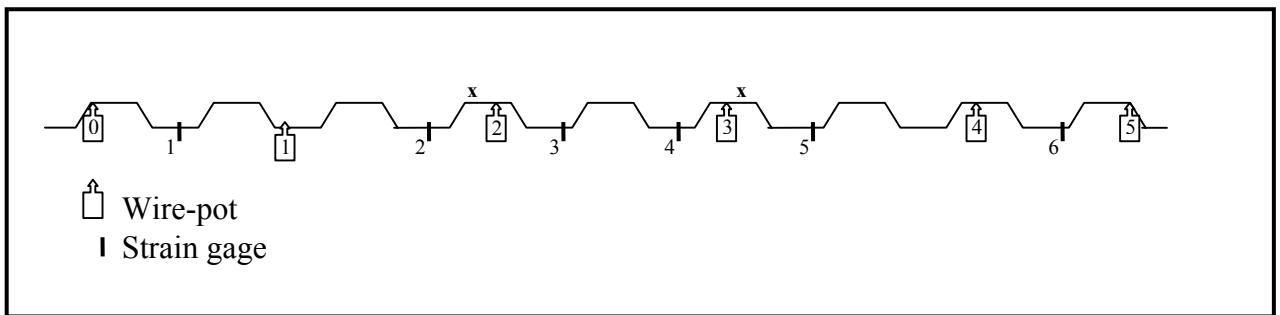

Figure F1-Strain Gage and Wire-Pot Locations across Mid-Span and Quarter-Points

Test Designation: WWF- Concentrated Loads
Cast Date: 06/29/2001
Test Date: 08/15/2001

Materials and Dimensions

General:

Width: 9 ft (3 panels)
Span length: 10 ft.
Type of Reinforcement: 25 lb/yd³ -1 ½” Xorex Fiber

Deck:

Deck type: 2VLI-20
Design Thickness: 0.0358 in
Height: 2 in
Area: 0.519 in²/ft
Yield Stress: 50 ksi
Ultimate Strength: 60 ksi

Concrete:

Test Strength: 3400 psi
Total Depth: 5.5 in

Results

Maximum Applied Load: 14.30 kips
Mid-Span Deflection at Maximum Load: 0.16 in
Quarter Point-1 Deflection at Maximum Load: 0.10 in
Quarter Point-2 Deflection at Maximum Load: 0.11 in
End Slip at Maximum Load: 0.00 in

Strains Due to Fresh Concrete (µε)

Strain Gage	1	2	3	4	5	6
Quarter Point-1	399.31	490.89	516.38	518.97	452.86	509.89
Mid-Span	497.93	602.20	717.61	687.59	540.41	615.64
Quarter Point-2	251.16	396.12	397.28	N/A	337.92	329.03

Table F-1: Non-Distributed Load Tests Data for WWF Slab

Slab: WWF

Test: Concentrated Load at Bottom Quarter Point (Fig. 5.3-A)

Strain Gage readings are in $\mu\text{in/in}$

Displacement readings are in in.

Strain Gage Number	Load in lbs												
	0	1400	2000.0	2500.0	3000.0	3500.0	4500.0	5000.0	5500.0	6000.0	6500.0	7000.0	7500.0
QPT-1	0.0	3.9	5.8	6.8	7.8	9.7	11.6	13.6	15.5	17.5	18.4	20.4	22.3
QPT-2	0.0	3.9	5.8	6.8	8.7	10.7	12.6	14.6	16.5	17.5	18.4	20.4	21.4
QPT-3	0.0	2.9	4.8	5.8	6.8	8.7	9.7	12.6	13.6	14.5	16.5	17.5	19.4
QPT-4	0.0	3.9	5.8	6.8	8.7	10.7	13.6	15.5	17.5	18.4	20.4	22.3	24.3
QPT-5	0.0	3.9	5.8	6.8	8.7	10.7	12.6	14.6	16.5	18.4	20.4	22.3	24.3
QPT-6	0.0	3.9	5.8	6.8	8.7	9.7	11.6	14.5	15.5	17.5	18.4	20.4	22.3
MS-1	0.0	6.8	10.7	12.6	15.5	18.5	23.3	27.2	30.1	33.0	36.9	40.8	44.7
MS-2	0.0	7.8	10.7	13.6	16.5	20.4	24.3	28.1	31.1	34.0	37.8	40.8	43.7
MS-3	0.0	6.8	10.7	12.6	15.5	18.4	22.3	25.2	28.1	30.1	33.0	35.9	37.9
MS-4	0.0	6.8	9.7	12.6	15.5	17.5	21.4	25.2	28.1	31.1	34.0	35.9	38.8
MS-5	0.0	7.8	10.7	13.6	16.5	19.4	24.3	28.2	31.1	34.0	36.9	39.8	43.7
MS-6	0.0	7.8	9.7	14.6	17.5	19.4	24.3	26.2	31.0	32.0	34.9	39.8	42.7
QPB-1	0.0	7.8	11.6	14.6	17.5	21.3	26.2	30.1	34.0	36.9	41.7	45.6	51.4
QPB-2	0.0	13.6	19.4	24.3	30.1	35.0	43.7	50.5	56.4	64.1	70.0	77.7	86.5
QPB-3	0.0	19.4	27.1	33.9	42.7	49.5	62.1	71.8	80.5	90.2	100.8	117.3	132.9
QPB-4	N/A	N/A	N/A	N/A	N/A	N/A	N/A	N/A	N/A	N/A	N/A	N/A	N/A
QPB-5	0.0	15.5	21.4	26.2	32.1	36.9	46.6	53.4	59.3	64.1	71.9	88.4	100.1
QPB-6	0.0	8.7	8.7	13.6	18.5	19.4	23.3	28.2	31.1	34.0	37.9	43.7	47.6
Displacement													
tqp-1	0.00	0.0043	0.0043	0.0043	0.0000	0.0000	0.0022	0.0000	0.0000	-0.0065	-0.0065	-0.0065	-0.0065
tqp-2	0.00	-0.0011	-0.0022	-0.0033	-0.0044	-0.0055	-0.0077	-0.0099	-0.0122	-0.0133	-0.0144	-0.0166	-0.0188
tqp-3	0.00	0.0000	0.0000	0.0000	0.0000	0.0000	0.0000	0.0000	0.0000	-0.0065	-0.0065	-0.0065	-0.0065
tqp-4	0.00	0.0000	0.0000	-0.0011	-0.0011	-0.0032	-0.0054	-0.0075	-0.0086	-0.0108	-0.0129	-0.0151	-0.0161
midspan-1	0.00	0.0000	0.0000	0.0067	0.0067	0.0067	0.0134	0.0156	0.0156	0.0201	0.0201	0.0201	0.0201
midspan-2	0.00	-0.0011	-0.0022	-0.0033	-0.0044	-0.0066	-0.0100	-0.0144	-0.0155	-0.0177	-0.0210	-0.0221	-0.0244
midspan-3	0.00	-0.0223	-0.0011	0.0067	0.0681	0.1083	0.0625	0.0480	0.0994	0.1038	0.0927	0.0759	0.0525
midspan-4	0.00	-0.0033	-0.0056	-0.0078	-0.0100	-0.0122	-0.0156	-0.0178	-0.0189	-0.0211	-0.0234	-0.0256	-0.0278
bqp-1	0.00	-0.0033	-0.0044	-0.0055	-0.0077	-0.0099	-0.0122	-0.0133	-0.0155	-0.0177	-0.0199	-0.0210	-0.0232
bqp-2	0.00	0.0000	0.0000	0.0000	-0.0046	-0.0091	-0.0137	-0.0137	-0.0137	-0.0228	-0.0182	-0.0182	-0.0274
bqp-3	0.00	0.0000	0.0000	-0.0046	-0.0046	-0.0046	-0.0138	-0.0138	-0.0138	-0.0183	-0.0183	-0.0183	-0.0275

Concentrated Load at Bottom Quarter Point Continued.

Strain Gage Number	Load in lbs.															
	8000	8500	9000	9500	10000	10500	11000	11500	12000	12300	12800	13300	13900	14300	14700	15000
QPT-1	24.244	25.214	27.154	29.093	30.063	32.003	33.942	35.882	37.822	39.761	41.701	43.641	45.58	47.52	48.49	49.46
QPT-2	23.304	24.275	26.217	28.159	29.13	30.101	32.043	33.985	34.956	36.899	37.87	39.812	41.754	43.696	44.667	44.667
QPT-3	20.361	22.3	23.27	24.24	26.179	27.148	28.118	30.057	31.027	31.997	34.906	33.936	34.906	35.875	36.845	37.815
QPT-4	26.21	28.152	30.094	32.035	33.006	34.948	36.889	38.831	40.773	41.743	43.685	44.656	46.598	47.568	48.539	49.51
QPT-5	26.2	27.17	29.111	31.052	32.022	34.934	35.904	37.845	39.786	40.756	41.727	42.697	44.638	45.609	46.579	47.549
QPT-6	23.279	25.219	27.159	28.129	29.099	32.009	32.979	34.919	36.859	38.799	39.769	41.709	43.649	45.589	46.559	47.529
MS-1	48.566	52.452	56.337	61.194	64.108	69.937	74.794	79.651	85.48	90.337	95.195	101.99	116.56	124.34	135.02	143.77
MS-2	47.555	49.496	52.408	56.29	58.231	61.143	64.055	66.967	70.849	72.79	74.732	75.702	78.614	80.555	83.467	85.409
MS-3	39.797	41.739	43.68	45.622	47.563	49.504	51.446	52.417	54.358	55.329	56.3	57.27	58.241	59.212	60.183	60.183
MS-4	40.767	42.709	45.621	48.533	49.504	52.416	54.357	56.299	58.24	60.182	62.123	64.065	66.006	66.977	68.919	69.889
MS-5	46.605	48.547	51.46	54.373	56.315	60.199	62.141	66.025	71.852	74.765	77.678	82.533	88.36	93.215	99.042	101.95
MS-6	45.604	49.486	51.427	55.308	58.219	62.101	65.012	68.894	72.775	76.657	79.568	83.45	87.332	90.243	92.184	94.125
QPB-1	56.269	61.12	67.912	75.674	82.466	92.168	118.36	142.62	175.62	189.2	204.73	221.23	239.67	248.41	259.08	269.76
QPB-2	95.218	103.96	117.56	135.05	147.69	163.24	179.76	203.08	223.5	238.08	259.46	283.76	316.81	332.37	350.84	338.2
QPB-3	137.7	149.34	174.56	213.35	223.06	238.58	239.55	245.37	253.13	263.8	268.65	267.68	266.71	271.56	281.26	268.65
QPB-4	N/A	N/A	N/A	N/A	N/A	N/A	N/A	N/A	N/A	N/A	N/A	N/A	N/A	N/A	N/A	N/A
QPB-5	108.83	119.52	130.21	142.85	152.57	165.2	176.87	192.42	207	218.67	240.05	267.27	291.58	309.08	326.58	336.3
QPB-6	51.481	57.309	61.195	67.023	72.852	77.709	82.566	89.366	99.081	107.82	138.91	181.66	198.18	208.87	219.56	227.33
Displacement																
tqp-1	0.0065	0.0130	0.0130	0.0130	0.0130	0.0130	0.0195	0.0195	0.0195	0.0195	0.0282	0.0282	0.028	0.035	0.035	0.035
tqp-2	0.0199	0.0210	0.0232	0.0243	0.0265	0.0276	0.0287	0.0298	0.0321	0.0343	0.0365	0.0387	0.042	0.044	0.046	0.049
tqp-3	0.0108	0.0129	0.0129	0.0129	0.0129	0.0194	0.0194	0.0194	0.0194	0.0258	0.0258	0.0258	0.032	0.032	0.032	0.039
tqp-4	0.0161	0.0172	0.0172	0.0215	0.0237	0.0258	0.0269	0.0280	0.0280	0.0291	0.0301	0.0312	0.038	0.041	0.042	0.043
midspan-1	0.0290	0.0268	0.0290	0.0334	0.0357	0.0334	0.0424	0.0401	0.0424	0.0491	0.0491	0.0535	0.056	0.062	0.062	0.0691
midspan-2	0.0277	0.0288	0.0310	0.0332	0.0354	0.0376	0.0399	0.0432	0.0465	0.0498	0.0531	0.0565	0.062	0.065	0.068	0.071
midspan-3	0.0279	0.0458	0.0212	0.0458	0.0714	0.0223	.0000	.0290	0.0915	0.0279	0.0815	0.0737	0.048	0.075	0.171	0.167
midspan-4	0.0289	0.0311	0.0334	0.0356	0.0378	0.0400	0.0423	0.0445	0.0478	0.0500	0.0534	0.0567	0.062	0.066	0.068	0.071
bqp-1	0.0254	0.0276	0.0298	0.0332	0.0343	0.0376	0.0398	0.0420	0.0442	0.0475	0.0497	0.0531	0.060	0.062	0.065	0.069
bqp-2	0.0274	0.0274	0.0319	0.0319	0.0411	0.0365	0.0456	0.0456	0.0547	0.0547	0.0593	-0.0593	-0.073	-0.078	-0.082	-0.087
bqp-3	-0.0275	-0.0275	-0.0321	-0.0367	-0.0321	-0.0413	-0.0413	-0.0459	-0.0459	-0.0505	-0.0550	-0.0642	-0.069	-0.073	-0.078	-0.078

Slab: WWF

Test: Concentrated Load at Mid-Span (Figure 5.3-B)

Strain Gage readings are in $\mu\text{in/in}$

Displacement readings are in inches

		Load in lbs.													
Strain Gage Number	0	632.2	1239.7	1559.9	2175.6	2610.8	3013.1	3604.2	3973.7	4499.1	5049.2	5476.1	6387.5	7052.5	7569.7
QPT-1	0	3.9	7.8	9.7	13.6	16.5	19.4	22.3	25.2	29.1	33.0	35.9	39.8	47.5	52.4
QPT-2	0	4.9	8.7	10.7	15.5	18.4	21.4	26.2	29.1	33.0	36.9	39.8	44.7	57.3	62.1
QPT-3	0	4.8	8.7	9.7	14.5	18.4	21.3	24.2	27.1	31.0	34.9	37.8	41.7	46.5	49.5
QPT-4	0	4.9	9.7	11.6	17.5	20.4	24.3	28.2	32.0	35.9	40.8	43.7	48.5	56.3	61.2
QPT-5	0	4.9	9.7	10.7	16.5	19.4	22.3	27.2	30.1	34.9	38.8	42.7	46.6	55.3	60.2
QPT-6	0	3.9	7.8	8.7	12.6	15.5	17.5	21.3	24.2	28.1	31.0	33.9	37.8	44.6	49.5
MS-1	0	6.8	13.6	16.5	25.3	30.1	35.9	42.7	48.6	55.4	62.2	68.0	75.8	91.3	101.0
MS-2	0	7.8	15.5	18.4	28.1	33.0	38.8	46.6	52.4	60.2	67.0	73.8	81.5	118.4	152.4
MS-3	0	8.7	17.5	20.4	30.1	35.9	42.7	50.5	56.3	64.1	71.8	78.6	97.1	160.2	181.5
MS-4	0	8.7	18.4	22.3	33.0	38.8	46.6	55.3	62.1	70.9	79.6	87.4	100.0	164.1	197.1
MS-5	0	6.8	14.6	17.5	26.2	31.1	37.9	44.7	50.5	57.3	65.1	70.9	78.7	96.1	110.7
MS-6	0	3.9	9.7	12.6	19.4	21.3	27.2	31.1	34.9	39.8	43.7	50.5	56.3	67.0	73.7
QPB-1	0	4.9	10.7	13.6	22.3	27.2	33.0	40.8	46.6	53.4	61.1	66.9	75.7	89.3	99.0
QPB-2	0	4.9	10.7	13.6	21.4	26.2	32.1	39.8	44.7	52.5	59.3	66.1	72.9	86.5	94.3
QPB-3	0	5.8	10.7	13.6	21.3	25.2	30.1	36.8	41.7	48.5	54.3	59.2	65.9	75.6	80.5
QPB-4	0	N/A	N/A	N/A	N/A	N/A	N/A	N/A	N/A	N/A	N/A	N/A	N/A	N/A	N/A
QPB-5	0	5.8	11.7	14.6	23.3	28.2	34.0	41.8	47.6	55.4	63.2	69.0	77.7	91.4	100.1
QPB-6	0	3.9	8.7	10.7	19.4	27.2	35.9	38.9	44.7	51.5	56.3	64.1	69.9	81.6	89.4
Displacement															
tqp-1	0	0.0000	0.0000	0.0000	-0.0065	-0.0065	-0.0065	-0.0109	-0.0152	-0.0130	-0.0130	-0.0195	-0.0217	-0.0282	-0.0282
tqp-2	0	-0.0011	-0.0022	-0.0044	-0.0088	-0.0099	-0.0122	-0.0155	-0.0177	-0.0199	-0.0221	-0.0254	-0.0265	-0.0321	-0.0354
tqp-3	0	0.0000	0.0000	0.0000	0.0000	0.0000	-0.0022	-0.0065	-0.0065	-0.0065	-0.0129	-0.0129	-0.0172	-0.0194	-0.0258
tqp-4	0	0.0000	0.0000	-0.0011	-0.0054	-0.0086	-0.0097	-0.0118	-0.0129	-0.0161	-0.0205	-0.0215	-0.0237	-0.0258	-0.0312
mid-span-1	0	0.0022	0.0067	0.0067	0.0067	0.0134	0.0134	0.0223	0.0223	0.0223	0.0290	0.0268	0.0357	0.0401	0.0424
mid-span-2	0	-0.0022	-0.0033	-0.0055	-0.0100	-0.0122	-0.0144	-0.0166	-0.0199	-0.0233	-0.0266	-0.0288	-0.0332	-0.0399	-0.0443
mid-span-3	0	0.0078	0.0179	-0.0022	-0.0882	-0.0714	-0.0569	-0.0502	-0.0614	-0.0167	0.0335	-0.0290	-0.0447	-0.0357	-0.0223
mid-span-4	0	-0.0011	-0.0044	-0.0067	-0.0111	-0.0122	-0.0156	-0.0189	-0.0211	-0.0234	-0.0278	-0.0300	-0.0345	-0.0400	-0.0434
bqp-1	0	0.0000	-0.0011	-0.0022	-0.0055	-0.0077	-0.0099	-0.0122	-0.0144	-0.0177	-0.0199	-0.0221	-0.0254	-0.0298	-0.0332
BQP-2	0	0.0000	0.0000	0.0000	0.0000	-0.0046	-0.0046	-0.0091	-0.0137	-0.0137	-0.0182	-0.0182	-0.0228	-0.0274	-0.0319
BQP-3	0	0.0000	0.0000	0.0000	-0.0046	-0.0046	-0.0046	-0.0138	-0.0138	-0.0138	-0.0183	-0.0183	-0.0275	-0.0275	-0.0367

Concentrated Load at Mid-Span Continued.

Strain Gage Number	Load in lbs.													
	7914.6	8513.9	8916.2	9441.7	9958.9	10451.0	10927.0	11395.0	11970.0	12454.0	13045.0	13382.0	13850.0	14302.0
QPT-1	55.3	61.1	65.9	70.8	76.6	82.4	88.3	90.2	92.1	104.7	116.4	123.2	132.9	146.5
QPT-2	66.0	73.8	78.7	83.5	88.4	92.3	97.1	101.0	106.8	111.7	118.5	126.2	146.6	164.1
QPT-3	51.4	54.3	56.2	59.1	62.1	64.0	65.9	68.8	72.7	76.6	151.3	200.7	231.8	259.9
QPT-4	64.1	68.9	71.8	74.8	78.6	81.6	85.4	89.3	95.1	104.9	113.6	119.4	135.0	158.3
QPT-5	64.0	69.9	73.8	78.6	84.4	90.3	97.0	103.8	111.6	121.3	133.9	140.7	153.3	166.0
QPT-6	52.4	57.2	61.1	66.0	70.8	75.7	79.5	82.5	87.3	95.1	101.9	105.7	114.5	128.1
MS-1	107.8	123.4	137.9	154.5	180.7	205.0	216.7	229.3	248.7	275.0	310.0	329.4	370.2	424.7
MS-2	171.8	188.3	203.8	222.3	242.7	271.8	298.0	331.0	368.0	395.1	425.3	444.7	420.4	452.5
MS-3	201.0	225.2	242.7	264.1	261.2	275.7	295.2	317.5	349.6	379.7	410.8	428.2	415.6	450.6
MS-4	221.4	236.9	252.4	262.1	270.9	284.5	306.8	330.1	360.2	391.3	436.0	460.3	476.8	506.0
MS-5	120.4	137.9	155.4	177.7	203.0	220.5	239.9	259.3	290.4	320.5	360.3	386.6	423.5	464.3
MS-6	76.7	85.4	93.2	102.9	111.6	123.2	157.2	177.6	201.9	226.1	259.1	281.5	308.6	354.3
QPB-1	103.8	113.5	121.3	130.0	138.8	148.5	155.3	163.0	172.7	182.4	194.1	200.9	212.5	221.3
QPB-2	98.1	105.9	111.8	118.6	124.4	129.2	135.1	139.9	145.8	150.6	158.4	163.3	158.4	157.4
QPB-3	83.4	89.2	93.1	98.9	107.6	115.4	122.2	130.0	138.7	148.4	166.8	177.5	184.3	197.9
QPB-4	N/A	N/A	N/A	N/A	N/A	N/A	N/A	N/A	N/A	N/A	N/A	N/A	N/A	N/A
QPB-5	105.0	113.7	119.5	127.3	134.1	141.9	148.7	156.5	166.2	175.0	190.5	198.3	214.8	260.5
QPB-6	93.3	102.0	105.9	114.6	122.4	131.2	138.0	144.8	155.4	164.2	172.0	178.8	192.4	213.8
Displacement														
tqp-1	-0.0282	-0.0369	-0.0347	-0.0413	-0.0413	-0.0499	-0.0499	-0.0565	-0.0608	-0.0630	-0.0717	-0.0782	-0.0847	-0.0912
tqp-2	-0.0376	-0.0420	-0.0453	-0.0486	-0.0520	-0.0564	-0.0608	-0.0663	-0.0718	-0.0774	-0.0862	-0.0906	-0.0984	-0.1072
tqp-3	-0.0258	-0.0323	-0.0323	-0.0387	-0.0387	-0.0452	-0.0452	-0.0516	-0.0602	-0.0645	-0.0731	-0.0731	-0.0796	-0.0925
tqp-4	-0.0345	-0.0377	-0.0398	-0.0409	-0.0463	-0.0538	-0.0549	-0.0581	-0.0624	-0.0678	-0.0754	-0.0807	-0.0840	-0.0947
mid-span-1	0.0424	0.0491	0.0557	0.0557	0.0624	0.0691	0.0758	0.0825	0.0892	0.0981	0.1048	0.1115	0.1226	0.1382
mid-span-2	-0.0476	-0.0554	-0.0576	-0.0620	-0.0675	-0.0764	-0.0819	-0.0897	-0.0974	-0.1085	-0.1207	-0.1284	-0.1406	-0.1594
mid-span-3	-0.0234	0.0134	0.0156	0.0100	0.0100	0.0000	-0.0056	0.0246	-0.0078	-0.0458	-0.0502	-0.0915	-0.0815	-0.0982
mid-span-4	-0.0456	-0.0500	-0.0545	-0.0578	-0.0634	-0.0689	-0.0734	-0.0801	-0.0879	-0.0934	-0.1034	-0.1090	-0.1168	-0.1312
bqp-1	-0.0354	-0.0376	-0.0398	-0.0431	-0.0475	-0.0497	-0.0542	-0.0586	-0.0630	-0.0685	-0.0752	-0.0785	-0.0851	-0.0940
BQP-2	-0.0319	-0.0411	-0.0411	-0.0456	-0.0456	-0.0547	-0.0547	-0.0593	-0.0639	-0.0730	-0.0776	-0.0867	-0.0912	-0.1004
BQP-3	-0.0367	-0.0367	-0.0413	-0.0413	-0.0459	-0.0550	-0.0550	-0.0642	-0.0642	-0.0688	-0.0780	-0.0826	-0.0917	-0.1055

Slab: WWF

Test: Concentrated Load at Top Quarter Point (Figure 5.3-C)

Strain Gage readings are in $\mu\text{in/in}$.

Displacement readings are in inches

		Load in lbs.													
Strain Gage	0	1247.9	1863.7	2331.6	2520.5	3095.2	3587.8	4203.6	4712.6	5213.4	5615.7	6124.7	6715.9	6986.8	7528.7
QPT-1	0	6.8	10.7	13.6	15.5	19.4	23.3	27.2	31.0	34.9	38.8	41.7	47.5	49.5	52.4
QPT-2	0	12.6	20.4	26.2	28.2	36.9	44.7	54.4	61.2	69.9	76.7	83.5	97.1	102.9	111.7
QPT-3	0	15.5	24.2	31.0	33.9	42.7	50.4	60.1	67.9	76.6	84.4	92.1	108.6	115.4	127.0
QPT-4	0	18.4	28.2	36.9	40.8	51.5	60.2	71.8	80.6	90.3	99.0	107.8	125.2	132.0	144.7
QPT-5	0	12.6	19.4	24.3	26.2	33.0	38.8	46.6	52.4	59.2	64.1	69.9	80.6	84.4	92.2
QPT-6	0	8.7	11.6	15.5	16.5	21.3	24.3	29.1	33.0	36.9	39.8	43.7	49.5	52.4	56.3
MS-1	0	12.6	19.4	25.3	28.2	36.9	43.7	53.4	62.2	70.9	76.8	83.6	94.2	98.1	104.9
MS-2	0	13.6	21.4	28.2	31.1	41.7	50.5	63.1	73.8	85.4	94.2	103.9	119.4	125.2	136.9
MS-3	0	14.6	22.3	30.1	33.0	43.7	53.4	67.0	77.7	89.3	98.1	106.8	121.4	127.2	137.9
MS-4	0	14.6	23.3	30.1	33.0	43.7	53.4	67.0	77.7	88.4	97.1	106.8	120.4	126.2	136.9
MS-5	0	13.6	21.4	29.1	32.1	41.8	49.5	60.2	69.0	77.7	85.5	92.3	103.9	107.8	117.5
MS-6	0	11.6	18.4	24.3	27.2	34.9	41.7	51.4	59.2	67.0	72.8	80.6	90.3	94.2	101.9
QPB-1	0	4.9	7.8	10.7	11.6	14.6	17.5	20.4	22.3	25.2	27.2	29.1	32.0	33.0	35.9
QPB-2	0	5.8	9.7	13.6	14.6	19.4	24.3	30.1	35.0	39.8	43.7	48.6	54.4	57.3	62.2
QPB-3	0	5.8	9.7	12.6	14.5	19.4	23.3	29.1	33.9	39.8	43.6	48.5	55.3	58.2	63.0
QPB-4	0	N/A	N/A	N/A	N/A	N/A	N/A	N/A	N/A	N/A	N/A	N/A	N/A	N/A	N/A
QPB-5	0	6.8	9.7	13.6	14.6	19.4	24.3	30.1	35.0	39.8	43.7	48.6	55.4	57.3	61.2
QPB-6	0	4.9	7.8	10.7	10.7	13.6	15.5	18.5	21.4	24.3	27.2	30.1	35.0	36.9	40.8
Displacement															
tqp-1	0.0000	0.0000	0.0000	0.0000	0.0043	0.0065	0.0065	0.0152	0.0130	0.0195	0.0195	0.0282	0.0282	0.0347	0.0347
tqp-2	0.0000	0.0033	0.0077	0.0111	0.0122	0.0155	0.0188	0.0232	0.0254	0.0298	0.0332	0.0365	0.0420	0.0442	0.0497
tqp-3	0.0000	0.0000	0.0000	0.0043	0.0043	0.0065	0.0065	0.0129	0.0129	0.0194	0.0194	0.0258	0.0344	0.0344	0.0409
tqp-4	0.0000	0.0011	0.0075	0.0097	0.0108	0.0129	0.0151	0.0172	0.0194	0.0248	0.0280	0.0301	0.0377	0.0388	0.0409
mid-span-1	0.0000	0.0089	0.0067	0.0089	0.0156	0.0134	0.0201	0.0201	0.0268	0.0268	0.0357	0.0334	0.0401	0.0491	0.0557
mid-span-2	0.0000	0.0033	0.0044	0.0055	0.0066	0.0122	0.0166	0.0210	0.0244	0.0299	0.0332	0.0365	0.0443	0.0465	0.0543
mid-span-3	0.0000	0.0357	0.0067	0.0458	0.0380	0.0022	0.0647	0.0525	0.0692	0.0860	0.0759	0.0703	0.0860	0.0837	0.1072
mid-span-4	0.0000	0.0044	0.0067	0.0100	0.0111	0.0145	0.0178	0.0222	0.0267	0.0311	0.0345	0.0378	0.0445	0.0467	0.0534
bqp-1	0.0000	0.0000	0.0033	0.0044	0.0044	0.0066	0.0088	0.0122	0.0144	0.0166	0.0188	0.0210	0.0254	0.0276	0.0321
BQP-2	0.0000	0.0046	0.0046	0.0046	0.0091	0.0091	0.0137	0.0137	0.0182	0.0228	0.0182	0.0228	0.0274	0.0274	0.0319
BQP-3	0.0000	0.0046	0.0046	0.0046	0.0046	0.0092	0.0138	0.0092	0.0183	0.0183	0.0138	0.0229	0.0321	0.0321	0.0321

Concentrated Load at Top Quarter Point Continued.

Strain Gage	Load in lbs.															
	8070.6	8505.7	8990.1	9532	10057	10484	10862	11412	11830	12372	12931	13292	13743	13940	14252	14860
QPT-1	56.3	60.1	64.0	68.9	73.7	77.6	81.5	86.3	91.2	98.9	108.6	114.5	128.0	170.7	195.9	249.3
QPT-2	122.4	132.1	141.8	154.4	167.0	175.8	185.5	197.2	209.8	230.2	265.2	281.7	319.6	286.5	319.6	380.8
QPT-3	138.7	151.3	162.9	180.4	194.9	205.6	217.2	231.8	245.4	253.1	252.2	261.9	273.5	297.8	336.6	394.8
QPT-4	158.3	166.0	178.6	193.2	206.8	216.5	227.2	240.8	253.4	267.0	267.0	276.7	272.8	290.3	315.6	363.2
QPT-5	100.9	110.6	118.4	129.1	138.8	146.6	155.3	166.0	176.6	193.2	219.4	230.0	241.7	256.3	250.4	266.0
QPT-6	61.1	66.0	70.8	76.6	81.5	85.4	90.2	96.0	99.9	106.7	113.5	116.4	126.1	146.5	157.2	196.0
MS-1	112.7	119.5	126.3	134.1	141.9	147.7	153.5	160.3	167.1	174.9	182.7	187.5	192.4	196.3	200.2	202.1
MS-2	148.6	158.3	168.9	181.6	193.2	202.0	210.7	222.4	232.1	244.7	257.3	266.1	278.7	266.1	265.1	270.0
MS-3	149.6	158.3	169.0	179.7	191.3	199.1	206.9	218.5	227.3	237.9	248.6	254.5	262.2	250.6	249.6	253.5
MS-4	147.6	155.4	165.1	174.8	183.5	190.3	197.1	206.9	214.6	223.4	233.1	239.9	246.7	248.6	256.4	267.1
MS-5	126.3	133.1	140.8	150.6	159.3	166.1	171.9	180.7	187.5	197.2	205.9	211.8	218.6	224.4	226.3	239.9
MS-6	109.7	116.5	125.2	134.0	142.7	149.5	156.3	164.1	171.8	181.5	190.3	197.1	204.8	213.6	219.4	236.9
QPB-1	38.8	40.7	42.7	45.6	48.5	50.5	52.4	55.3	58.2	61.1	64.0	66.0	67.9	68.9	71.8	73.7
QPB-2	68.0	71.9	76.8	82.6	88.4	92.3	97.2	102.0	106.9	113.7	119.5	123.4	129.2	128.3	131.2	136.0
QPB-3	68.9	72.7	77.6	82.4	88.2	92.1	96.0	101.8	106.7	112.5	119.3	124.1	130.0	130.0	132.9	138.7
QPB-4	N/A	N/A	N/A	N/A	N/A	N/A	N/A	N/A	N/A	N/A	N/A	N/A	N/A	N/A	N/A	N/A
QPB-5	66.1	70.0	73.9	78.7	82.6	85.5	88.4	93.3	96.2	101.1	105.0	108.8	112.7	119.5	124.4	135.1
QPB-6	44.7	47.6	51.5	55.4	59.3	62.2	65.1	68.0	70.9	74.8	78.7	81.6	85.5	87.4	87.4	89.4
Displacement																
tqp-1	0.0434	0.0456	0.0499	0.0565	0.0608	0.0630	0.0695	0.0695	0.0760	0.0847	0.0912	0.0956	0.1042	0.1260	0.1412	0.1694
tqp-2	0.0542	0.0586	0.0641	0.0707	0.0774	0.0818	0.0862	0.0928	0.0984	0.1050	0.1139	0.1205	0.1304	0.1536	0.1691	0.1979
tqp-3	0.0473	0.0473	0.0538	0.0602	0.0645	0.0667	0.0731	0.0796	0.0796	0.0860	0.0989	0.0989	0.1054	0.1269	0.1398	0.1591
tqp-4	0.0463	0.0517	0.0528	0.0581	0.0646	0.0689	0.0721	0.0764	0.0818	0.0861	0.0904	0.0947	0.1034	0.1163	0.1238	0.1400
mid-span-1	0.0557	0.0624	0.0691	0.0758	0.0825	0.0892	0.0959	0.0959	0.1026	0.1115	0.1249	0.1226	0.1315	0.1516	0.1583	0.1784
mid-span-2	0.0609	0.0653	0.0742	0.0819	0.0875	0.0930	0.0974	0.1041	0.1096	0.1185	0.1262	0.1306	0.1384	0.1528	0.1639	0.1827
mid-span-3	0.1038	0.1072	0.0927	0.0759	0.0826	0.0860	0.0848	0.0871	0.0781	0.1083	0.0737	0.0960	0.1038	0.0871	0.0737	0.0424
mid-span-4	0.0589	0.0645	0.0712	0.0778	0.0845	0.0890	0.0956	0.1012	0.1056	0.1145	0.1223	0.1246	0.1312	0.1412	0.1490	0.1635
bqp-1	0.0354	0.0387	0.0420	0.0464	0.0497	0.0531	0.0564	0.0608	0.0641	0.0685	0.0741	0.0763	0.0807	0.0906	0.0962	0.1072
BQP-2	0.0365	0.0365	0.0456	0.0456	0.0547	0.0547	0.0593	0.0684	0.0639	0.0730	0.0821	0.0776	0.0867	0.0912	0.1004	0.1049
BQP-3	0.0367	0.0367	0.0459	0.0505	0.0550	0.0596	0.0596	0.0688	0.0688	0.0734	0.0826	0.0826	0.0872	0.0963	0.1009	0.1101

Slab: WWF

Test: Concentrated Load at Top Third Point (Figure 5.3-D)

Strain Gage readings are in $\mu\text{in/in}$

Displacement readings are in inches.

Strain Gage	Load in lbs.															
	0	681.44	1346.4	1568.1	2068.9	2487.6	3136.2	3612.4	4129.7	4507.3	5123.1	5509	6001.6	6666.6	7044.3	7602.6
QPT-1	0	5.8	12.6	14.5	21.3	26.2	34.9	41.7	48.5	53.3	61.1	66.9	73.7	83.4	89.2	97.0
QPT-2	0	7.8	17.5	21.4	31.1	38.8	53.4	65.1	76.7	86.4	100.0	108.8	119.5	133.1	140.8	151.5
QPT-3	0	9.7	21.3	25.2	36.9	46.5	64.0	76.6	91.2	100.9	116.4	126.1	138.7	153.2	162.0	173.6
QPT-4	0	10.7	22.3	27.2	37.9	47.6	64.1	75.7	89.3	99.0	113.6	122.3	134.0	148.6	156.3	168.0
QPT-5	0	7.8	16.5	19.4	27.2	34.0	45.6	53.4	61.1	67.9	77.6	84.4	92.2	103.9	109.7	119.4
QPT-6	0	4.9	11.6	13.6	18.4	23.3	31.0	36.9	42.7	46.6	53.4	58.2	64.0	72.8	77.6	84.4
MS-1	0	9.7	20.4	24.3	34.0	41.8	54.4	64.1	73.8	80.6	91.3	98.1	105.9	116.6	122.4	132.1
MS-2	0	9.7	22.3	27.2	37.9	47.6	65.0	77.7	92.2	102.9	121.4	132.0	145.6	164.1	173.8	188.4
MS-3	0	10.7	23.3	28.2	39.8	49.5	66.0	79.6	94.2	103.9	120.4	130.1	141.8	158.3	167.0	180.6
MS-4	0	10.7	23.3	28.2	39.8	50.5	68.9	82.5	97.1	107.8	124.3	135.0	147.6	164.1	173.8	188.4
MS-5	0	10.7	23.3	28.2	38.8	47.6	62.2	72.8	84.5	93.2	106.8	115.6	127.2	142.8	151.5	164.2
MS-6	0	8.7	20.4	24.3	34.9	42.7	56.3	66.0	75.7	83.5	95.1	102.9	112.6	126.2	134.0	145.6
QPB-1	0	3.9	7.8	9.7	13.6	15.5	19.4	22.3	25.2	28.1	31.0	34.0	36.9	41.7	44.6	48.5
QPB-2	0	4.9	9.7	12.6	17.5	22.3	31.1	36.9	43.7	47.6	55.4	59.3	64.1	71.9	75.8	82.6
QPB-3	0	4.8	10.7	12.6	18.4	23.3	32.0	37.8	45.6	50.4	58.2	63.0	67.9	75.6	79.5	86.3
QPB-4	0	N/A	N/A	N/A	N/A	N/A	N/A	N/A	N/A	N/A	N/A	N/A	N/A	N/A	N/A	N/A
QPB-5	0	4.9	10.7	12.6	18.5	23.3	33.0	38.9	46.6	51.5	59.3	64.1	70.0	77.7	81.6	87.5
QPB-6	0	3.9	7.8	8.7	11.7	14.6	18.5	22.3	26.2	30.1	35.0	37.9	41.8	47.6	51.5	55.4
Displacement																
tqp-1	0	0.0022	0.0043	0.0043	0.0043	0.0130	0.0195	0.0261	0.0261	0.0347	0.0391	0.0478	0.0521	0.0630	0.0695	0.0760
tqp-2	0	0.0022	0.0066	0.0088	0.0133	0.0177	0.0232	0.0287	0.0354	0.0409	0.0486	0.0531	0.0619	0.0718	0.0763	0.0829
tqp-3	0	0.0000	0.0000	0.0000	0.0022	0.0043	0.0108	0.0172	0.0237	0.0237	0.0301	0.0366	0.0430	0.0516	0.0581	0.0645
tqp-4	0	0.0011	0.0022	0.0022	0.0075	0.0108	0.0194	0.0226	0.0248	0.0301	0.0345	0.0366	0.0452	0.0528	0.0571	0.0646
mid-span-1	0	0.0045	0.0111	0.0111	0.0178	0.0178	0.0245	0.0312	0.0379	0.0468	0.0535	0.0602	0.0669	0.0803	0.0870	0.0936
mid-span-2	0	0.0011	0.0055	0.0078	0.0122	0.0177	0.0244	0.0310	0.0388	0.0443	0.0520	0.0598	0.0675	0.0808	0.0864	0.0963
mid-span-3	0	0.0045	0.0201	0.0301	4.4318	4.3414	4.2733	4.2331	4.2085	4.1672	4.2297	4.1817	4.1784	4.1862	4.2108	4.1605
mid-span-4	0	0.0011	0.0056	0.0067	0.0122	0.0156	0.0234	0.0289	0.0356	0.0400	0.0478	0.0534	0.0612	0.0734	0.0790	0.0879
bqp-1	0	0.0011	0.0044	0.0044	0.0077	0.0099	0.0144	0.0188	0.0232	0.0254	0.0309	0.0343	0.0398	0.0464	0.0508	0.0564
BQP-2	0	0.0091	0.5794	0.5839	0.5885	0.5885	0.5976	0.5976	0.5976	0.6022	0.6068	0.6113	0.6204	0.6296	0.6296	0.6341
BQP-3	0	0.0000	0.0000	0.0092	0.0092	0.0092	0.0138	0.0229	0.0183	0.0321	0.0367	0.0367	0.0459	0.0505	0.0596	0.0642

Concentrated Load at Top Third Point Continued

	Load in lbs.														
Strain Gage	7947.4	8596	9022.9	9663.3	9983.5	10484	11001	11781	11962	12413	12865	13325	13883	14351	14573
QPT-1	102.8	112.5	119.3	130.0	134.8	143.6	152.3	167.8	171.7	183.3	201.8	219.2	238.6	257.1	292.0
QPT-2	159.3	171.9	180.7	194.3	201.1	210.8	222.4	240.9	245.8	259.4	275.9	293.4	315.7	335.2	374.0
QPT-3	182.3	195.9	204.7	218.2	225.0	235.7	247.3	266.7	271.6	285.2	300.7	315.3	333.7	351.2	388.0
QPT-4	175.7	189.3	198.1	212.6	221.4	233.0	246.6	271.9	278.7	295.2	315.6	335.0	364.2	393.3	463.3
QPT-5	125.2	135.9	143.7	156.3	162.1	170.8	181.5	200.9	205.8	214.5	212.6	218.4	199.0	220.3	291.2
QPT-6	89.3	98.0	103.8	111.6	116.4	123.2	130.0	139.7	141.6	146.5	152.3	160.1	176.6	194.0	309.5
MS-1	138.0	149.6	157.4	169.1	174.9	184.6	193.4	208.9	212.8	221.6	232.3	242.9	258.5	275.0	300.3
MS-2	197.1	214.6	225.3	240.8	248.6	260.2	273.8	294.2	299.1	312.7	328.2	342.8	356.4	368.1	383.6
MS-3	188.4	203.9	213.7	227.3	234.1	244.7	256.4	275.8	281.7	294.3	308.9	324.4	339.9	352.6	369.1
MS-4	197.1	213.7	224.3	236.0	242.8	249.6	261.3	279.7	284.6	296.2	310.8	325.4	339.0	351.6	363.3
MS-5	171.9	186.5	196.2	210.8	217.6	230.2	241.9	260.4	264.2	275.9	292.4	309.9	328.4	342.0	314.8
MS-6	152.4	166.0	174.7	188.3	194.2	205.8	216.5	228.1	231.1	239.8	252.4	264.1	273.8	288.4	278.6
QPB-1	51.4	56.3	59.2	64.0	66.0	70.8	74.7	80.5	81.5	86.4	91.2	96.1	101.9	105.8	111.6
QPB-2	86.5	94.2	100.1	107.9	110.8	116.6	122.4	130.2	132.1	137.0	143.8	149.6	155.5	159.4	166.2
QPB-3	90.2	98.9	103.8	110.6	114.4	119.3	124.1	131.9	134.8	138.7	144.5	151.3	156.1	160.0	164.9
QPB-4	N/A	N/A	N/A	N/A	N/A	N/A	N/A	N/A	N/A	N/A	N/A	N/A	N/A	N/A	N/A
QPB-5	91.4	99.1	104.0	111.8	115.7	121.5	129.3	140.0	142.9	151.6	161.3	170.1	181.8	189.5	186.6
QPB-6	59.3	64.1	67.0	72.9	75.8	80.6	84.5	97.1	99.1	105.9	112.7	118.5	124.4	130.2	128.2
Displacement															
tqp-1	0.0760	0.0890	0.0934	0.1042	0.1042	0.1108	0.1194	0.1325	0.1325	0.1433	0.1542	0.1672	0.1889	0.2106	0.2389
tqp-2	0.0895	0.1006	0.1050	0.1150	0.1205	0.1271	0.1337	0.1459	0.1503	0.1614	0.1746	0.1901	0.2122	0.2332	0.2664
tqp-3	0.0710	0.0774	0.0839	0.0903	0.0968	0.1032	0.1097	0.1226	0.1290	0.1355	0.1484	0.1677	0.1892	0.2043	0.2408
tqp-4	0.0678	0.0721	0.0786	0.0861	0.0937	0.0969	0.1001	0.1141	0.1163	0.1217	0.1346	0.1475	0.1637	0.1776	0.2143
mid-span-1	0.1003	0.1093	0.1159	0.1293	0.1360	0.1427	0.1494	0.1628	0.1650	0.1784	0.1895	0.2051	0.2252	0.2453	0.2742
mid-span-2	0.1030	0.1129	0.1207	0.1306	0.1351	0.1450	0.1528	0.1683	0.1716	0.1838	0.1982	0.2148	0.2358	0.2524	0.2790
mid-span-3	4.1773	4.2141	4.2130	4.2264	4.2197	4.2588	4.2275	4.1650	4.1471	4.1103	4.0980	4.0601	4.0377	4.0935	4.1092
mid-span-4	0.0934	0.1045	0.1101	0.1190	0.1234	0.1312	0.1379	0.1512	0.1546	0.1646	0.1790	0.1946	0.2135	0.2335	0.2624
bqp-1	0.0597	0.0663	0.0707	0.0774	0.0807	0.0862	0.0906	0.0984	0.1017	0.1072	0.1150	0.1249	0.1360	0.1448	0.1592
BQP-2	0.6387	0.6432	0.6478	0.6569	0.6615	0.6615	0.6706	0.6752	0.6797	0.6889	0.6934	0.6980	0.7162	0.7208	0.7436
BQP-3	0.0642	0.0688	0.0780	0.0872	0.0872	0.0917	0.1009	0.1055	0.1055	0.1147	0.1193	0.1330	0.1422	0.1560	0.1697

Slab: WWF

Test: Concentrated Load at Bottom Third Point (Figure 5.3-E)

Strain Gage Readings are in $\mu\text{in/in}$

Displacement Readings are in inches.

Strain Gage Number	Load in lbs.													
	0	1206.8	1584.5	2151	2610.8	3078.8	3538.5	4137.9	4605.9	5443.3	6116.5	6576.3	7216.7	7520.5
QPT-1	0	6.8	9.7	13.6	16.5	20.4	23.3	26.2	30.1	35.9	41.7	45.6	51.4	54.3
QPT-2	0	7.8	11.7	18.5	24.3	30.1	36.9	43.7	49.5	60.2	67.0	70.9	76.7	79.6
QPT-3	0	9.7	13.6	21.3	28.1	34.9	41.7	49.5	56.2	66.9	74.7	79.5	85.3	88.3
QPT-4	0	8.7	12.6	21.4	28.2	35.9	42.7	51.5	58.3	69.9	77.7	82.5	89.3	93.2
QPT-5	0	8.7	11.6	18.4	24.3	30.1	35.9	42.7	47.6	57.3	64.1	67.9	74.7	77.6
QPT-6	0	6.8	8.7	13.6	17.5	20.4	24.3	29.1	33.0	39.8	45.6	50.4	57.2	60.1
MS-1	0	20.4	27.2	39.8	49.6	59.3	69.0	80.6	90.4	106.9	119.5	128.3	143.8	149.6
MS-2	0	23.3	32.0	46.6	60.2	73.8	88.4	106.8	121.4	145.6	166.0	179.6	198.1	207.8
MS-3	0	23.3	32.0	47.6	60.2	74.8	88.4	106.8	121.4	144.7	163.1	175.8	187.4	197.1
MS-4	0	22.3	31.1	46.6	60.2	74.8	89.3	108.8	124.3	149.6	169.0	181.6	194.2	203.9
MS-5	0	21.4	29.1	41.8	52.4	65.1	75.8	90.3	102.0	122.4	137.9	148.6	164.2	171.9
MS-6	0	16.5	23.3	34.0	43.7	53.4	64.1	76.7	87.4	105.8	120.4	129.1	144.6	150.5
QPB-1	0	12.6	16.5	21.3	26.2	31.0	35.9	42.7	47.5	57.2	64.0	68.9	78.6	82.5
QPB-2	0	20.4	27.2	37.9	46.6	55.4	63.2	72.9	81.6	95.2	104.9	111.7	124.4	129.2
QPB-3	0	21.3	28.1	39.8	47.5	56.2	65.0	76.6	85.3	100.9	112.5	120.3	134.8	140.6
QPB-4	0	N/A	N/A	N/A	N/A	N/A	N/A	N/A	N/A	N/A	N/A	N/A	N/A	N/A
QPB-5	0	18.5	24.3	34.0	41.8	50.5	58.3	69.0	76.8	92.3	103.0	118.6	133.1	137.0
QPB-6	0	11.7	15.5	23.3	30.1	36.9	44.7	53.4	59.3	71.9	81.6	88.4	100.1	104.9
Displacement														
tqp-1	0	0.0000	0.0000	0.0000	0.0065	0.0065	0.0130	0.0217	0.0217	0.0326	0.0413	0.0413	0.0565	0.0565
tqp-2	0	0.0033	0.0066	0.0111	0.0144	0.0177	0.0221	0.0287	0.0332	0.0420	0.0464	0.0542	0.0652	0.0674
tqp-3	0	0.0000	0.0000	0.0000	0.0000	0.0043	0.0065	0.0129	0.0194	0.0258	0.0344	0.0387	0.0473	0.0538
tqp-4	0	0.0011	0.0022	0.0043	0.0075	0.0129	0.0172	0.0215	0.0258	0.0345	0.0388	0.0441	0.0549	0.0603
mid-span-1	0	0.0067	0.0045	0.0134	0.0201	0.0290	0.0312	0.0424	0.0468	0.0602	0.0758	0.0803	0.0959	0.1026
mid-span-2	0	0.0044	0.0100	0.0155	0.0210	0.0299	0.0354	0.0454	0.0520	0.0642	0.0764	0.0853	0.0996	0.1041
mid-span-3	0	0.0112	0.0045	0.0033	0.0179	0.0179	0.0257	0.0558	0.0614	0.0703	0.0826	0.0558	0.1005	0.1585
mid-span-4	0	0.0067	0.0100	0.0156	0.0222	0.0278	0.0334	0.0434	0.0500	0.0634	0.0756	0.0834	0.0956	0.1012
bqp-1	0	0.0055	0.0077	0.0122	0.0155	0.0199	0.0254	0.0309	0.0354	0.0453	0.0531	0.0586	0.0696	0.0730
BQP-2	0	0.0046	0.0000	0.0091	0.0137	0.0182	0.0228	0.0319	0.0365	0.0502	0.0547	0.0639	0.0730	0.0776
BQP-3	0	0.0046	0.0046	0.0092	0.0138	0.0229	0.0229	0.0321	0.0367	0.0550	0.0596	0.0688	0.0826	0.0826

Concentrated Load at Bottom Third Point Continued.

Strain Gage Number	Load in lbs.													
	8111.6	8505.7	8899.8	9449.9	9885	10213	11420	12019	12471	12816	13349	13686	14285	14876
QPT-1	60.1	64.0	68.9	74.7	79.5	83.4	98.0	104.8	108.6	112.5	119.3	123.2	130.0	136.8
QPT-2	86.4	91.3	96.2	102.0	106.8	111.7	126.3	134.0	139.9	143.8	150.6	154.4	160.3	166.1
QPT-3	95.0	99.9	103.8	109.6	115.4	121.2	136.8	146.5	152.3	156.2	162.9	166.8	173.6	178.5
QPT-4	99.0	103.9	108.8	114.6	120.4	125.3	139.8	149.5	154.4	158.3	165.1	169.0	174.8	180.6
QPT-5	84.4	89.3	95.1	101.9	108.7	113.6	128.1	136.9	143.7	148.5	156.3	160.2	167.0	174.7
QPT-6	66.0	69.9	75.7	82.5	90.2	94.1	111.6	125.2	132.0	135.8	142.6	146.5	154.3	162.0
MS-1	162.3	171.0	179.8	192.4	201.2	208.0	236.2	255.6	269.2	279.9	298.4	312.0	333.4	354.8
MS-2	225.3	236.0	246.6	261.2	273.8	288.4	324.4	345.7	358.4	367.1	382.6	394.3	410.8	424.4
MS-3	212.7	223.4	231.1	242.8	252.5	263.2	293.3	311.8	323.4	332.2	347.7	358.4	374.9	392.4
MS-4	219.5	229.2	237.9	251.5	261.3	271.0	302.1	322.5	335.1	344.8	358.4	367.2	380.8	395.3
MS-5	186.5	196.2	205.9	219.5	232.2	242.9	277.8	296.3	308.0	317.7	332.3	340.0	356.6	373.1
MS-6	161.1	169.9	179.6	192.2	203.9	209.7	234.0	247.6	262.1	271.8	284.5	291.3	307.8	326.2
QPB-1	90.2	97.0	103.8	118.4	150.4	211.5	351.3	390.2	420.3	442.6	481.4	517.4	582.5	653.4
QPB-2	140.9	149.6	159.4	178.8	214.8	263.4	355.7	390.7	415.0	438.4	475.3	506.4	565.8	631.9
QPB-3	153.2	162.9	173.6	192.0	222.1	261.9	342.4	379.3	404.5	424.9	462.7	491.9	558.8	642.3
QPB-4	N/A	N/A	N/A	N/A	N/A	N/A	N/A	N/A	N/A	N/A	N/A	N/A	N/A	N/A
QPB-5	148.7	156.5	165.2	182.7	209.0	250.8	342.2	378.1	406.3	432.6	483.2	521.1	590.2	655.4
QPB-6	112.7	118.5	126.3	138.0	160.3	196.3	275.0	301.2	322.6	343.0	390.7	431.5	489.8	544.3
Displacement														
tqp-1	0.0630	0.0695	0.0782	0.0847	0.0999	0.1064	0.1346	0.1477	0.1564	0.1629	0.1759	0.1911	0.2041	0.2258
tqp-2	0.0752	0.0807	0.0884	0.0951	0.1083	0.1172	0.1448	0.1581	0.1702	0.1791	0.1934	0.2045	0.2222	0.2421
tqp-3	0.0602	0.0667	0.0731	0.0796	0.0925	0.0989	0.1333	0.1462	0.1527	0.1656	0.1785	0.1914	0.2043	0.2258
tqp-4	0.0657	0.0689	0.0764	0.0851	0.0915	0.1034	0.1270	0.1432	0.1497	0.1572	0.1690	0.1787	0.1949	0.2099
mid-span-1	0.1070	0.1182	0.1315	0.1427	0.1583	0.1784	0.2185	0.2475	0.2609	0.2742	0.3010	0.3166	0.3500	0.3790
mid-span-2	0.1196	0.1262	0.1362	0.1528	0.1694	0.1893	0.2358	0.2613	0.2801	0.2978	0.3255	0.3454	0.3809	0.4152
mid-span-3	0.1362	0.1172	0.1518	0.1585	0.1764	0.1797	0.1753	0.1786	0.1875	0.1429	0.1351	0.0480	0.1105	0.0860
mid-span-4	0.1134	0.1212	0.1301	0.1435	0.1601	0.1802	0.2313	0.2569	0.2736	0.2869	0.3125	0.3281	0.3592	0.3914
bqp-1	0.0818	0.0884	0.0951	0.1061	0.1205	0.1393	0.1835	0.2067	0.2233	0.2388	0.2598	0.2752	0.3062	0.3393
BQP-2	0.0867	0.0867	0.1049	0.1095	0.1323	0.1505	0.1962	0.2235	0.2372	0.2555	0.2783	0.3011	0.3330	0.3741
BQP-3	0.0917	0.0917	0.1101	0.1193	0.1376	0.1560	0.2064	0.2294	0.2477	0.2615	0.2844	0.3073	0.3440	0.3807

Slab: WWF

Test: Longitudinal Linear Load along middle strip (Figure 5.3-F)

Strain Gage Readings are in $\mu\text{in}/\text{in}$.

Displacement readings are in inches.

		Load in lbs.															
Strain Gage	0	1510.6	2101.8	3333.3	4080.4	4950.7	6009.8	7085.3	8045.9	9187.1	10049	10894	11929	12766	13669	14655	15139
QPT-1	0	14.5	21.3	37.8	48.5	63.0	80.5	98.0	114.5	132.9	147.4	162.0	178.5	193.1	207.6	224.1	231.9
QPT-2	0	21.4	33.0	61.2	78.7	100.0	119.5	140.8	160.3	186.5	203.0	219.5	239.0	254.5	269.1	285.6	294.4
QPT-3	0	24.2	37.8	66.9	85.3	103.8	126.1	148.4	167.8	197.9	215.3	232.8	252.2	268.7	283.3	301.7	309.5
QPT-4	0	24.3	36.9	68.0	87.4	106.8	130.1	152.5	172.8	197.1	215.6	233.1	253.5	268.0	283.6	301.1	309.8
QPT-5	0	20.4	32.0	59.2	76.7	95.1	116.5	137.8	157.2	179.6	195.1	210.6	228.1	241.7	255.3	270.8	278.6
QPT-6	0	16.5	25.2	44.6	57.2	72.8	92.2	111.6	129.0	150.4	165.9	180.5	197.9	211.5	226.1	243.6	251.3
MS-1	0	32.1	45.7	74.8	92.3	113.7	140.9	168.1	194.4	223.5	245.9	266.3	291.6	312.0	333.4	360.6	373.2
MS-2	0	35.9	53.4	95.1	122.3	154.4	191.3	227.2	258.3	293.3	319.5	343.8	371.0	394.3	416.6	442.9	455.5
MS-3	0	35.9	53.4	94.2	119.4	147.6	180.6	212.7	240.9	272.9	296.2	319.6	345.8	367.2	388.5	412.8	424.5
MS-4	0	35.9	53.4	95.2	122.4	151.5	185.5	218.5	247.7	280.7	305.9	328.3	356.5	377.8	399.2	424.5	437.1
MS-5	0	35.9	51.5	86.4	108.8	135.0	167.1	198.2	225.4	255.5	277.8	299.2	323.5	343.0	363.4	386.7	398.4
MS-6	0	29.1	42.7	72.8	92.2	114.5	140.8	167.9	191.2	220.4	239.8	258.2	281.5	300.0	319.4	342.7	354.4
QPB-1	0	19.4	27.2	49.5	67.9	92.2	128.1	165.0	199.9	237.8	265.0	290.2	318.4	342.7	366.0	398.0	410.7
QPB-2	0	25.3	37.9	70.9	92.3	115.7	147.7	180.8	210.0	244.0	269.3	293.6	320.8	344.1	367.5	393.7	405.4
QPB-3	0	25.2	38.8	70.8	92.1	117.4	150.4	184.3	214.4	249.3	276.5	300.8	329.9	354.1	377.4	404.6	417.2
QPB-4	0	N/A	N/A	N/A	N/A	N/A	N/A	N/A	N/A	N/A	N/A	N/A	N/A	N/A	N/A	N/A	N/A
QPB-5	0	22.4	32.1	61.2	80.7	106.0	138.0	171.1	200.3	235.3	259.6	284.9	313.1	337.4	358.8	385.1	399.7
QPB-6	0	15.5	24.3	46.6	62.2	82.6	112.7	140.9	168.1	194.3	216.7	238.1	260.4	279.9	301.3	325.6	336.3
Displacement																	
tqp-1	0	0.0043	0.0065	0.0282	0.0413	0.0565	0.0760	0.0977	0.1194	0.1412	0.1607	0.1759	0.1889	0.2041	0.2237	0.2389	0.2541
tqp-2	0	0.0088	0.0144	0.0332	0.0453	0.0641	0.0884	0.1105	0.1304	0.1559	0.1724	0.1890	0.2078	0.2266	0.2432	0.2653	0.2741
tqp-3	0	0.0000	0.0000	0.0194	0.0344	0.0473	0.0731	0.0925	0.1161	0.1398	0.1591	0.1720	0.1935	0.2064	0.2258	0.2473	0.2602
tqp-4	0	0.0075	0.0108	0.0269	0.0398	0.0560	0.0743	0.0947	0.1130	0.1303	0.1443	0.1572	0.1733	0.1873	0.2013	0.2229	0.2304
mid-span-1	0	0.0067	0.0111	0.0401	0.0535	0.0736	0.1070	0.1360	0.1650	0.1984	0.2185	0.2386	0.2676	0.2876	0.3077	0.3367	0.3500
mid-span-2	0	0.0100	0.0177	0.0421	0.0598	0.0841	0.1185	0.1517	0.1794	0.2137	0.2380	0.2624	0.2890	0.3122	0.3355	0.3665	0.3798
mid-span-3	0	0.0078	0.0022	0.0011	0.0067	0.0067	0.0089	0.0067	0.0078	0.0045	0.0045	0.0045	0.0502	0.0491	0.0614	0.0357	0.0223
mid-span-4	0	0.0122	0.0211	0.0434	0.0601	0.0823	0.1145	0.1468	0.1757	0.2057	0.2291	0.2480	0.2725	0.2936	0.3147	0.3436	0.3536
bqp-1	0	0.0077	0.0133	0.0309	0.0431	0.0619	0.0851	0.1072	0.1293	0.1536	0.1702	0.1868	0.2067	0.2211	0.2376	0.2598	0.2719
BQP-2	0	0.0046	0.0091	0.0228	0.0365	0.0547	0.0867	0.1095	0.1323	0.1551	0.1734	0.1962	0.2144	0.2327	0.2464	0.2737	0.2828
BQP-3	0	0.0092	0.0138	0.0367	0.0459	0.0642	0.0917	0.1193	0.1422	0.1651	0.1881	0.2018	0.2248	0.2431	0.2569	0.2844	0.2936

Slab: WWF

Test: Longitudinal Linear Load along Left Third Point Strip (Figure 5.3-G)

Strain Gage Readings are in $\mu\text{in}/\text{in}$.

Displacement readings are in inches.

Strain Gage	Load in lbs.															
	0	1330	2003.2	3054.1	4088.6	5180.6	6083.7	7126.4	8193.7	9178.9	10188	11313	12011	12504	13719	14573
QPT-1	0	22.3	36.9	61.1	87.3	112.5	133.9	158.1	181.4	202.8	223.1	245.5	259.0	267.8	291.1	308.5
QPT-2	0	24.3	39.8	68.0	94.2	118.5	137.9	162.2	186.5	207.9	229.3	252.6	267.1	278.8	306.0	326.4
QPT-3	0	24.2	41.7	68.9	95.0	119.3	138.7	161.0	184.3	205.6	228.0	252.2	265.8	277.4	307.5	328.9
QPT-4	0	22.3	36.9	63.1	88.4	111.7	129.1	150.5	172.8	192.3	212.7	235.0	249.6	260.3	284.6	304.0
QPT-5	0	15.5	27.2	48.5	67.9	86.4	101.9	119.4	136.9	152.4	168.9	186.4	197.0	204.8	222.3	236.9
QPT-6	0	3.9	5.8	12.6	22.3	34.9	46.6	60.1	72.8	84.4	96.0	108.7	115.5	121.3	134.9	142.6
MS-1	0	36.0	54.4	86.5	122.4	159.4	190.5	226.4	262.4	294.5	326.6	361.6	383.9	400.5	445.2	488.0
MS-2	0	35.9	58.2	96.1	135.0	172.8	202.9	236.0	269.0	298.1	328.2	359.3	377.8	390.4	422.5	444.8
MS-3	0	35.0	57.3	96.1	134.0	170.9	200.1	232.1	264.2	292.3	321.5	352.6	372.0	384.7	417.7	442.0
MS-4	0	33.0	55.3	92.2	129.2	165.1	194.2	225.3	257.4	286.5	314.7	345.8	365.2	379.8	412.8	439.1
MS-5	0	28.2	45.6	73.8	102.0	131.1	154.4	181.7	207.9	231.2	254.5	278.8	293.4	304.1	330.3	350.7
MS-6	0	21.4	34.9	58.2	83.5	107.7	129.1	152.4	174.7	194.2	213.6	234.9	248.5	258.2	280.6	300.0
QPB-1	0	23.3	38.8	71.8	114.5	155.3	196.1	241.7	284.4	322.3	361.1	400.0	425.2	444.6	481.6	509.7
QPB-2	0	26.2	42.8	73.9	106.9	139.0	167.2	200.2	233.3	263.4	293.6	327.6	348.0	365.5	400.5	432.6
QPB-3	0	25.2	41.7	68.9	99.9	130.9	158.1	190.1	222.1	250.3	279.4	312.4	332.8	350.2	382.3	414.3
QPB-4	0	N/A	N/A	N/A	N/A	N/A	N/A	N/A	N/A	N/A	N/A	N/A	N/A	N/A	N/A	N/A
QPB-5	0	17.5	29.2	51.5	78.7	106.0	130.3	158.5	186.7	211.9	237.2	263.5	275.1	287.8	315.0	336.4
QPB-6	0	8.7	14.6	25.3	39.8	60.2	77.7	99.1	120.5	136.0	153.5	173.0	183.7	190.5	217.7	234.2
Displacement																
tqp-1	0	0.0065	0.0217	0.0413	0.0630	0.0912	0.1129	0.1412	0.1629	0.1824	0.2041	0.2302	0.2476	0.2606	0.2888	0.3171
tqp-2	0	0.0099	0.0144	0.0343	0.0553	0.0774	0.0995	0.1216	0.1437	0.1647	0.1846	0.2056	0.2211	0.2376	0.2587	0.2819
tqp-3	0	0.0000	0.0000	0.0129	0.0323	0.0538	0.0731	0.0925	0.1118	0.1333	0.1527	0.1720	0.1849	0.2000	0.2193	0.2387
tqp-4	0	0.0000	0.0032	0.0140	0.0291	0.0452	0.0624	0.0786	0.0969	0.1087	0.1227	0.1400	0.1475	0.1583	0.1733	0.1884
mid-span-1	0	0.0156	0.0290	0.0557	0.0892	0.1249	0.1516	0.1873	0.2207	0.2564	0.2832	0.3166	0.3389	0.3590	0.3946	0.4348
mid-span-2	0	0.0111	0.0199	0.0432	0.0720	0.1030	0.1340	0.1661	0.1960	0.2270	0.2569	0.2879	0.3067	0.3277	0.3554	0.3919
mid-span-3	0	0.0022	0.0089	0.0134	0.0100	0.0100	0.0134	0.0156	0.0123	0.0167	0.0145	0.0167	0.0179	0.0223	0.0223	0.0904
mid-span-4	0	0.0056	0.0111	0.0289	0.0500	0.0745	0.1001	0.1279	0.1568	0.1813	0.2035	0.2291	0.2435	0.2636	0.2802	0.3058
bqp-1	0	0.0122	0.0243	0.0453	0.0674	0.0917	0.1161	0.1437	0.1713	0.1934	0.2144	0.2399	0.2564	0.2752	0.2995	0.3316
BQP-2	0	0.0091	0.0137	0.0319	0.0502	0.0730	0.0912	0.1186	0.1460	0.1688	0.1870	0.2144	0.2281	0.2464	0.2692	0.2920
BQP-3	0	0.0000	0.0092	0.0229	0.0413	0.0642	0.0826	0.1101	0.1330	0.1560	0.1743	0.1972	0.2110	0.2294	0.2523	0.2706

Slab: WWF

Test: Longitudinal Linear Load along Right Third Point Strip (Figure 5.3-H)

Strain Gage Readings are in $\mu\text{in}/\text{in}$.

Displacement Readings are in inches.

Strain Gage	Load in lbs.															
	0	1453.2	1986.8	3078.8	4137.9	5073.8	6083.7	7068.9	8152.7	9170.7	10024	11001	12068	13029	14121	15065
QPT-1	0	5.8	7.8	15.5	25.2	34.9	46.6	58.2	70.8	82.4	92.1	102.8	114.5	124.2	136.8	148.4
QPT-2	0	18.5	28.2	48.6	69.0	85.5	102.0	118.5	137.0	153.5	168.0	184.6	203.0	220.5	242.9	264.2
QPT-3	0	24.2	35.9	60.1	83.4	100.9	120.3	138.7	159.1	178.5	195.0	215.3	236.7	255.1	279.4	302.7
QPT-4	0	27.2	38.8	65.1	91.3	109.7	129.1	148.6	170.9	191.3	208.8	228.2	249.6	270.0	296.2	323.4
QPT-5	0	26.2	38.8	67.0	95.1	117.4	141.7	165.0	189.3	210.6	228.1	248.5	269.9	290.3	316.5	344.6
QPT-6	0	30.1	41.7	66.0	92.2	115.5	141.7	164.9	188.2	209.6	227.1	244.5	264.9	284.3	310.5	336.7
MS-1	0	22.3	32.1	54.4	75.8	94.3	116.6	139.0	162.3	184.6	204.1	224.5	245.9	266.3	289.6	313.0
MS-2	0	32.0	48.5	81.6	115.5	145.6	177.7	208.8	241.8	271.9	297.1	324.3	353.5	380.7	411.8	440.0
MS-3	0	34.0	49.5	81.6	114.6	141.8	169.9	197.1	226.3	252.5	274.9	299.2	326.4	351.6	380.8	406.0
MS-4	0	35.9	51.5	86.4	121.4	152.5	184.5	214.6	247.7	276.8	301.1	328.3	357.4	383.7	413.8	440.0
MS-5	0	36.9	52.4	86.4	123.4	155.4	188.4	220.5	255.5	286.6	312.8	341.0	369.2	393.5	420.7	445.0
MS-6	0	18.5	0.0	30.1	53.4	88.4	-327.3	-58.3	20.4	50.5	98.1	129.2	145.8	109.8	145.8	173.0
QPB-1	0	11.6	16.5	31.1	55.3	78.6	109.7	138.8	166.9	194.1	213.5	233.9	255.3	273.7	295.1	314.5
QPB-2	0	24.3	36.9	66.1	97.2	122.5	152.6	179.8	209.9	237.2	259.5	284.8	311.1	335.4	362.6	386.0
QPB-3	0	27.2	40.7	69.8	102.8	130.9	163.0	191.1	226.0	258.1	282.3	308.5	336.7	362.9	393.0	420.1
QPB-4	0	N/A	N/A	N/A	N/A	N/A	N/A	N/A	N/A	N/A	N/A	N/A	N/A	N/A	N/A	N/A
QPB-5	0	29.2	41.8	73.9	108.9	139.0	174.0	207.1	244.0	275.1	303.4	333.5	366.6	398.7	432.7	461.9
QPB-6	0	26.2	39.8	70.9	105.9	136.0	173.0	207.0	243.9	277.0	303.2	329.5	355.7	380.0	406.3	431.6
Displacement																
tqp-1	0	0.0000	0.0065	0.0130	0.0347	0.0499	0.0673	0.0847	0.1064	0.1194	0.1390	0.1542	0.1694	0.1824	0.2020	0.2172
tqp-2	0	0.0088	0.0122	0.0309	0.0497	0.0674	0.0928	0.1127	0.1360	0.1547	0.1735	0.1912	0.2100	0.2299	0.2520	0.2730
tqp-3	0	0.0065	0.0108	0.0280	0.0495	0.0667	0.0925	0.1183	0.1398	0.1656	0.1849	0.2064	0.2258	0.2451	0.2666	0.2924
tqp-4	0	0.0075	0.0183	0.0366	0.0571	0.0764	0.1012	0.1195	0.1443	0.1637	0.1809	0.2003	0.2218	0.2379	0.2627	0.2853
mid-span-1	0	0.0045	0.0111	0.0268	0.0468	0.0669	0.0936	0.1226	0.1516	0.1761	0.1984	0.2163	0.2453	0.2676	0.2876	0.3121
mid-span-2	0	0.0111	0.0177	0.0410	0.0664	0.0930	0.1262	0.1572	0.1871	0.2170	0.2436	0.2735	0.3000	0.3222	0.3521	0.3798
mid-span-3	0	0.0123	0.0112	0.0112	0.0179	0.0078	0.0145	0.0201	0.0234	0.0223	0.0167	0.0045	0.0089	0.0100	0.0145	0.0089
mid-span-4	0	0.0200	0.0300	0.0578	0.0901	0.1179	0.1546	0.1891	0.2235	0.2558	0.2814	0.3092	0.3392	0.3648	0.3992	0.4348
bqp-1	0	0.0044	0.0088	0.0210	0.0398	0.0564	0.0763	0.0962	0.1183	0.1382	0.1536	0.1713	0.1879	0.2045	0.2200	0.2376
BQP-2	0	0.0091	0.0137	0.0274	0.0502	0.0684	0.0958	0.1186	0.1414	0.1688	0.1870	0.2053	0.2281	0.2464	0.2646	0.2920
BQP-3	0	0.0092	0.0183	0.0367	0.0596	0.0780	0.1147	0.1330	0.1606	0.1881	0.2110	0.2294	0.2523	0.2752	0.3028	3.2431

Slab: WWF

Test: Transverse Linear Load along Mid-Span (Figure 5.3-I)

Strain Gage Readings are in $\mu\text{in/in}$.

Displacement readings are in inches.

Strain Gage	Load in lbs.															
	0	1256.1	2003.2	3144.4	3973.7	5008.2	6026.2	7085.3	7988.5	9146.1	10221	10804	11814	12627	13735	14926
QPT-1	0	13.6	25.2	48.5	66.0	87.3	109.6	131.9	150.4	173.6	196.0	209.5	236.7	262.9	301.7	345.4
QPT-2	0	23.3	41.8	69.9	89.4	115.6	139.9	166.1	188.4	214.7	239.0	249.7	269.1	287.6	316.7	344.9
QPT-3	0	28.1	47.5	75.7	97.0	124.2	148.4	174.6	195.9	224.1	249.3	261.0	280.4	294.9	314.3	339.6
QPT-4	0	28.2	48.5	75.7	96.1	121.4	145.7	171.9	194.2	223.4	247.6	259.3	276.8	289.4	309.8	330.2
QPT-5	0	24.3	44.6	75.7	98.0	124.2	148.5	174.7	196.1	223.3	247.5	262.1	286.4	308.7	338.8	374.8
QPT-6	0	17.5	30.1	52.4	71.8	95.1	118.4	141.7	163.0	189.2	213.5	229.0	257.1	282.4	316.3	357.1
MS-1	0	39.8	65.1	108.8	139.9	177.8	215.7	253.7	286.7	330.5	376.2	407.3	470.5	544.4	674.8	835.3
MS-2	0	53.4	94.2	158.3	202.0	256.4	304.9	356.4	401.1	461.3	525.5	575.0	681.0	799.6	987.3	1222.7
MS-3	0	48.6	88.4	152.5	196.2	247.7	292.3	340.0	382.7	441.0	510.0	568.3	678.2	795.9	979.7	1223.9
MS-4	0	56.3	99.0	164.1	207.8	260.3	307.9	357.4	402.1	462.4	533.3	596.5	722.9	861.0	1082.8	1383.6
MS-5	0	48.6	81.6	136.0	173.9	217.6	256.5	296.3	332.3	380.9	434.3	471.3	545.1	635.6	784.4	990.7
MS-6	0	N/A	N/A	N/A	N/A	N/A	N/A	N/A	N/A	N/A	N/A	N/A	N/A	N/A	N/A	N/A
QPB-1	0	16.5	29.1	63.1	94.1	133.0	170.8	212.6	245.6	288.3	322.3	342.7	374.7	397.0	422.3	455.3
QPB-2	0	25.3	45.7	79.7	108.9	143.8	178.8	215.8	245.9	282.9	315.9	334.4	365.5	390.8	423.9	459.9
QPB-3	0	25.2	43.6	77.6	106.7	143.6	179.5	215.4	246.4	284.3	316.3	334.7	360.9	382.3	408.5	437.6
QPB-4	0	N/A	N/A	N/A	N/A	N/A	N/A	N/A	N/A	N/A	N/A	N/A	N/A	N/A	N/A	N/A
QPB-5	0	22.4	38.9	74.9	102.1	138.0	171.1	209.0	240.2	275.2	309.2	327.7	359.8	384.1	420.1	460.0
QPB-6	0	19.4	33.0	62.2	89.4	121.5	153.5	187.5	212.8	244.9	273.1	288.6	318.8	345.0	382.9	434.5
Displacement																
tqp-1	0	0.0065	0.0217	0.0499	0.0760	0.0999	0.1325	0.1607	0.1846	0.2128	0.2411	0.2541	0.2953	0.3323	0.3974	0.4756
tqp-2	0	0.0077	0.0243	0.0553	0.0807	0.1094	0.1382	0.1680	0.1912	0.2233	0.2531	0.2719	0.3084	0.3471	0.4156	0.5007
tqp-3	0	0.0000	0.0129	0.0452	0.0710	0.0989	0.1247	0.1591	0.1849	0.2129	0.2387	0.2580	0.2989	0.3376	0.3978	0.4838
tqp-4	0	0.0054	0.0194	0.0484	0.0678	0.0904	0.1163	0.1443	0.1626	0.1895	0.2186	0.2347	0.2649	0.3015	0.3575	0.4285
mid-span-1	0	0.0156	0.0357	0.0758	0.1115	0.1516	0.1940	0.2363	0.2676	0.3032	0.3478	0.3746	0.4281	0.4927	0.5819	0.7068
mid-span-2	0	0.0144	0.0354	0.0853	0.1218	0.1650	0.2081	0.2558	0.2945	0.3388	0.3842	0.4163	0.4772	0.5469	0.6599	0.8060
mid-span-3	0	0.0067	0.0022	0.0000	0.0056	0.0022	0.0078	0.0134	0.0100	0.0089	0.0078	0.0011	0.0134	0.0100	0.0123	0.0100
mid-span-4	0	0.0178	0.0356	0.0778	0.1123	0.1524	0.1935	0.2335	0.2647	0.3047	0.3447	0.3714	0.4270	0.4860	0.5783	0.6961
bqp-1	0	0.0111	0.0243	0.0564	0.0796	0.1083	0.1393	0.1691	0.1945	0.2233	0.2520	0.2697	0.3062	0.3449	0.4046	0.4742
BQP-2	0	0.0091	0.0228	0.0502	0.0730	0.1049	0.1323	0.1642	0.1916	0.2281	0.2555	0.2692	0.3102	0.3513	0.4060	0.4881
BQP-3	0	0.0138	0.0275	0.0550	0.0826	0.1147	0.1422	0.1789	0.2064	0.2385	0.2706	0.2890	0.3257	0.3578	0.4220	0.5046

Slab: WWF

Test: Transverse Linear Load along Top Quarter Point (Figure 5.3-J)

Strain Gage Readings are in $\mu\text{in/in}$.

Displacement Readings are in inches.

Strain Gage	Load in lbs.														
	0	2266	3037.7	3949	5016.4	5960.5	7085.3	8234.8	9096.8	10180	11141	12077	12775	13908	14844
QPT-1	0	38.8	55.3	76.6	99.9	122.2	148.4	173.6	193.1	219.3	245.5	273.6	302.7	353.2	397.8
QPT-2	0	68.0	96.2	124.3	159.3	187.5	219.5	252.6	277.8	310.9	343.9	380.8	418.7	494.6	564.6
QPT-3	0	77.6	107.7	142.6	180.4	210.5	245.4	281.3	307.5	344.4	381.3	420.1	463.8	548.2	625.9
QPT-4	0	75.7	105.8	140.8	177.7	208.8	244.7	281.6	309.8	348.6	391.4	437.1	484.7	574.1	660.6
QPT-5	0	55.3	79.6	107.7	137.8	162.1	190.3	218.4	239.8	267.9	297.1	328.1	366.0	445.7	523.4
QPT-6	0	48.5	66.9	89.3	115.5	138.7	165.9	192.1	211.5	237.7	263.0	291.1	325.1	379.4	437.7
MS-1	0	37.9	52.5	71.9	95.3	116.6	144.8	175.0	197.3	226.5	251.8	275.1	294.6	326.7	352.9
MS-2	0	47.6	67.0	90.3	120.5	146.7	180.7	214.7	240.0	274.0	303.2	329.4	350.8	384.8	410.1
MS-3	0	45.7	65.1	88.4	117.6	143.8	175.9	209.9	235.2	266.3	293.5	318.8	338.3	368.4	393.7
MS-4	0	41.8	59.3	81.7	109.8	136.1	169.2	203.2	228.5	260.6	288.8	315.0	334.5	363.6	388.9
MS-5	0	44.7	61.2	81.6	106.9	131.2	160.3	190.5	213.8	243.0	269.2	293.5	312.0	339.2	364.5
MS-6	0	35.0	48.6	66.0	86.4	106.8	133.0	160.2	179.7	205.9	229.2	250.6	266.1	290.4	311.8
QPB-1	0	15.5	20.4	25.2	33.0	41.7	55.3	69.9	81.5	97.1	112.6	125.2	134.9	150.4	163.1
QPB-2	0	22.4	32.1	44.7	57.3	67.1	81.6	97.2	110.8	127.3	142.9	157.5	170.1	189.6	206.1
QPB-3	0	25.2	35.9	49.5	64.0	73.7	88.3	104.8	118.4	135.8	151.3	166.9	178.5	197.9	215.4
QPB-4	0	N/A	N/A	N/A	N/A	N/A	N/A	N/A	N/A	N/A	N/A	N/A	N/A	N/A	N/A
QPB-5	0	20.4	29.2	39.9	50.6	61.2	75.8	93.3	106.0	123.5	140.0	155.6	167.2	183.8	200.3
QPB-6	0	15.5	20.4	26.2	34.0	42.8	54.4	66.1	77.7	92.3	104.9	118.6	128.3	142.8	155.5
Displacement															
tqp-1	0	0.0195	0.0347	0.0478	0.0695	0.0912	0.1108	0.1412	0.1629	0.1889	0.2106	0.2324	0.2606	0.2975	0.3257
tqp-2	0	0.0254	0.0376	0.0542	0.0774	0.0995	0.1271	0.1581	0.1802	0.2089	0.2343	0.2598	0.2863	0.3382	0.3802
tqp-3	0	0.0129	0.0280	0.0473	0.0667	0.0860	0.1140	0.1462	0.1656	0.1935	0.2193	0.2408	0.2666	0.3118	0.3526
tqp-4	0	0.0194	0.0301	0.0452	0.0581	0.0764	0.1012	0.1227	0.1410	0.1647	0.1863	0.2067	0.2293	0.2670	0.3025
mid-span-1	0	0.0201	0.0357	0.0491	0.0691	0.0892	0.1249	0.1516	0.1806	0.2074	0.2341	0.2631	0.2854	0.3255	0.3590
mid-span-2	0	0.0188	0.0299	0.0454	0.0675	0.0930	0.1273	0.1594	0.1838	0.2148	0.2447	0.2735	0.2989	0.3377	0.3753
mid-span-3	0	0.0011	0.0033	0.0033	0.0011	0.0000	0.0022	0.0045	0.0067	0.0089	0.0067	0.0056	0.0078	0.0078	0.0112
mid-span-4	0	0.0211	0.0345	0.0478	0.0689	0.0901	0.1190	0.1501	0.1724	0.2013	0.2302	0.2547	0.2791	0.3192	0.3536
bqp-1	0	0.0099	0.0166	0.0254	0.0376	0.0531	0.0707	0.0895	0.1061	0.1271	0.1437	0.1603	0.1746	0.1990	0.2189
BQP-2	0	0.0137	0.0137	0.0274	0.0411	0.0547	0.0684	0.0867	0.1095	0.1277	0.1460	0.1597	0.1779	0.1962	0.2190
BQP-3	0	0.0138	0.0229	0.0275	0.0413	0.0550	0.0780	0.0963	0.1101	0.1330	0.1514	0.1651	0.1789	0.2064	0.2248

Slab: WWF

Test: Transverse Linear Load along Bottom Quarter Point (Figure 5.3-K)

Strain Gage Readings are in $\mu\text{in}/\text{in}$.

Displacement Readings are in inches.

		Load in lbs.														
Strain Gage	0	1330	2175.6	3013.1	4055.8	5180.6	6050.9	7216.7	8004.9	9096.8	9893.2	10788	11756	12889	13883	14770
QPT-1	0	5.8	9.7	12.6	17.5	25.2	32.0	42.7	50.4	61.1	69.8	79.5	90.2	103.8	114.5	124.2
QPT-2	0	11.7	22.3	33.0	43.7	54.4	60.2	69.9	77.7	89.4	97.1	106.8	117.5	130.2	139.9	150.6
QPT-3	0	14.5	28.1	43.6	58.2	70.8	77.6	86.3	94.1	103.8	112.5	123.2	134.8	149.4	161.0	172.6
QPT-4	0	14.6	29.1	42.7	56.3	68.9	76.7	87.4	95.1	106.8	116.5	127.2	139.8	153.4	163.1	173.8
QPT-5	0	9.7	19.4	30.1	42.7	55.3	65.0	77.6	87.4	100.9	110.6	121.3	133.0	147.5	160.2	172.8
QPT-6	0	9.7	16.5	22.3	30.1	39.8	49.5	62.1	68.9	81.5	91.2	101.9	113.5	128.1	139.7	151.4
MS-1	0	19.4	31.1	43.7	61.2	82.6	101.1	128.3	148.7	175.0	197.3	222.6	249.9	282.0	307.2	330.6
MS-2	0	22.3	39.8	59.3	84.5	113.7	135.0	168.1	191.4	222.5	246.8	273.0	301.2	336.2	362.5	387.8
MS-3	0	21.4	38.9	58.3	83.6	111.8	134.1	164.3	184.7	213.8	235.2	258.6	283.8	313.0	335.4	356.8
MS-4	0	22.4	38.9	59.3	84.6	114.7	137.1	167.2	188.6	216.8	238.2	262.5	287.8	316.0	338.4	358.8
MS-5	0	22.3	39.8	56.4	78.7	104.0	123.4	151.6	172.0	201.2	224.5	249.8	278.0	309.1	334.4	359.6
MS-6	0	18.4	31.1	42.7	61.2	84.5	102.9	130.1	148.6	174.8	195.2	217.6	244.8	272.9	297.2	317.6
QPB-1	0	24.3	48.5	77.6	119.4	166.0	206.7	264.0	300.9	348.5	380.5	419.4	463.1	530.1	579.7	633.1
QPB-2	0	38.9	73.9	110.8	156.5	202.2	237.2	282.9	312.0	352.9	385.0	421.9	475.4	562.0	622.3	690.4
QPB-3	0	41.7	80.5	120.3	168.8	218.3	257.1	306.6	339.6	385.2	420.1	465.7	527.9	627.9	700.7	777.4
QPB-4	0	N/A	N/A	N/A	N/A	N/A	N/A	N/A	N/A	N/A	N/A	N/A	N/A	N/A	N/A	N/A
QPB-5	0	35.0	66.1	101.1	142.9	184.7	218.8	262.5	292.7	333.5	361.7	394.8	435.7	506.7	561.2	623.5
QPB-6	0	30.1	56.4	86.5	127.3	165.2	196.3	235.2	260.4	293.5	319.8	348.9	381.0	439.3	487.0	534.7
Displacement																
tqp-1	0	0.00217	0.00217	0.01520	0.02172	0.04126	0.05646	0.07166	0.08469	0.10640	0.12161	0.13464	0.15635	0.18458	0.19979	0.22150
tqp-2	0	0.00774	0.01326	0.02211	0.03537	0.04974	0.06300	0.08401	0.09727	0.11716	0.13043	0.14701	0.16911	0.20006	0.21775	0.23322
tqp-3	0	0.00000	0.00215	0.00860	0.02365	0.03655	0.04946	0.06881	0.09031	0.10321	0.12256	0.13546	0.15481	0.18922	0.20212	0.22147
tqp-4	0	0.00108	0.00861	0.01615	0.02907	0.04199	0.05491	0.07429	0.08506	0.10228	0.11412	0.12919	0.14534	0.17011	0.18518	0.20456
mid-span-1	0	0.01338	0.02007	0.03567	0.05574	0.08250	0.10925	0.13823	0.15830	0.19174	0.21181	0.24302	0.26978	0.31660	0.34336	0.37457
mid-span-2	0	0.00664	0.01661	0.02879	0.04982	0.07861	0.10628	0.14171	0.16607	0.19707	0.22032	0.25132	0.28565	0.33768	0.36869	0.40079
mid-span-3	0	0.00335	0.00447	0.00558	0.00558	0.01116	0.00893	0.00670	0.00781	0.01005	0.00893	0.00112	0.00112	0.00112	0.00112	0.00112
mid-span-4	0	0.01223	0.02224	0.03781	0.06228	0.09119	0.11454	0.14679	0.16680	0.19794	0.22018	0.24798	0.27912	0.32805	0.35585	0.38588
bqp-1	0	0.00774	0.01879	0.03095	0.05306	0.07848	0.09727	0.12711	0.14480	0.17022	0.19122	0.21443	0.24428	0.29512	0.32165	0.34928
BQP-2	0	0.00456	0.02281	0.03193	0.05931	0.08668	0.10492	0.13686	0.15967	0.18704	0.21441	0.23722	0.27828	0.33302	0.36952	0.40602
BQP-3	0	0.01376	0.02294	0.04128	0.06422	0.09174	0.11009	0.14678	0.16972	0.19724	0.21559	0.24311	0.27981	0.33027	0.36238	0.39908

Test Designation: XOREX25- Concentrated Loads
Cast Date: 07/17/2001
Test Date: 08/22/2001

Materials and Dimensions

General:

Width: 9 ft (3 panels)
Span length: 10 ft.
Type of Reinforcement: 25 lb/yd³ -1 ½” Xorex Fiber

Deck:

Deck type: 2VLI-20
Design Thickness: 0.0358 in
Height: 2 in
Area: 0.519 in²/ft
Yield Stress: 50 ksi
Ultimate Strength: 60 ksi

Concrete:

Test Strength: 4000 psi
Total Depth: 5.5 in

Results

Maximum Applied Load: 13.72 kips
Mid-Span Deflection at Maximum Load: 0.12 in
Quarter Point-1 Deflection at Maximum Load: 0.077 in
Quarter Point-2 Deflection at Maximum Load: 0.083 in
End Slip at Maximum Load: 0.00 in

Strains Due to Fresh Concrete (µε)

Strain Gage	1	2	3	4	5	6
Quarter Point-1	536.83	N/A	518.81	503.02	578.09	N/A
Mid-Span	746.91	690.20	733.98	757.67	790.95	752.06
Quarter Point-2	N/A	575.53	555.49	563.97	552.48	539.39

Table F-2 Non-Distributed Load Tests Data for XOREX-25 Slab
Slab: XOREX-25

Test: Concentrated Load at Bottom Quarter Point (Figure 5.3-A)

Strain Gage Readings are in $\mu\text{in}/\text{in}$.

Deflection Readings are in inches.

Strain Gage	Load in lbs.													
	0	492.61	1551.7	2126.4	2536.9	3095.2	3760.2	4655.1	4605.9	5270.9	6026.2	6543.5	6954	7495.8
QPT-1	0	1.94	4.85	5.82	6.79	8.72	10.66	13.57	13.57	15.51	17.45	19.39	21.33	22.30
QPT-2	0	0.97	3.88	5.82	7.76	9.70	11.64	14.54	15.51	18.42	21.33	23.27	25.21	27.15
QPT-3	0	0.97	3.88	5.82	7.76	9.70	12.61	14.55	15.52	18.43	21.34	23.28	25.22	27.16
QPT-4	0	0.97	3.88	5.82	7.76	9.70	11.64	14.55	15.52	18.42	21.33	23.27	25.21	27.15
QPT-5	0	1.94	4.85	6.79	8.73	10.67	13.58	16.49	16.49	19.39	23.27	25.21	27.15	29.09
QPT-6	0	0.97	4.85	5.82	6.78	8.72	10.66	13.57	13.57	15.51	18.42	19.39	21.32	22.29
MS-1	0	1.94	7.75	10.66	12.60	15.51	19.39	23.27	24.23	28.11	31.99	34.90	37.81	40.71
MS-2	0	1.94	7.76	10.67	12.61	15.52	19.40	23.28	24.25	27.16	32.01	33.95	36.86	39.77
MS-3	0	-0.59	-2.06	-2.65	-3.24	-4.13	-5.01	-5.90	-5.90	-6.78	-7.67	-8.55	-8.85	-9.73
MS-4	0	1.94	6.80	8.74	10.68	12.62	16.50	19.42	19.42	22.33	25.24	27.18	28.16	31.07
MS-5	0	2.91	8.73	11.64	13.58	17.46	21.34	25.23	26.20	30.08	34.93	37.84	40.75	43.66
MS-6	0	1.94	6.79	9.70	11.64	14.55	17.46	21.34	21.34	25.22	29.10	32.01	33.95	36.86
QPB-1	0	2.91	8.74	11.65	14.57	17.48	21.36	27.19	27.19	31.07	35.93	38.84	41.76	44.67
QPB-2	0	N/A	N/A	N/A	N/A	N/A	N/A	N/A	N/A	N/A	N/A	N/A	N/A	N/A
QPB-3	0	5.82	20.37	29.10	34.92	44.62	57.23	70.81	71.78	83.43	97.01	106.70	114.47	124.17
QPB-4	0	5.82	20.37	29.10	35.89	45.59	58.20	71.78	72.75	85.36	99.91	109.61	117.37	127.07
QPB-5	0	4.85	15.53	21.36	26.21	33.01	41.75	51.45	52.42	60.19	69.90	77.67	82.52	89.32
QPB-6	0	2.96	8.89	10.86	13.82	17.77	21.72	25.67	26.66	30.61	35.54	38.51	41.47	44.43
Displacement														
TQP-0	0	0.0022	0.0022	0.0022	0.0022	0.0022	0.0022	0.0043	0.0065	0.0043	0.0065	0.0065	0.0065	0.0129
tqp-1	0	0.0000	0.0000	0.0000	0.0000	0.0000	0.0000	0.0000	0.0000	0.0000	0.0065	0.0065	0.0065	0.0065
tqp-2	0	0.0000	0.0011	0.0033	0.0044	0.0055	0.0066	0.0088	0.0088	0.0111	0.0133	0.0144	0.0155	0.0166
tqp-3	0	0.0022	0.0022	0.0022	0.0022	0.0022	0.0022	0.0022	0.0022	0.0000	0.0000	0.0022	0.0022	0.0022
tqp-4	0	0.0000	0.0000	0.0000	0.0011	0.0032	0.0043	0.0054	0.0054	0.0054	0.0075	0.0086	0.0097	0.0108
TQP-5	0	0.0000	0.0000	0.0000	0.0000	0.0000	0.0000	0.0046	0.0046	0.0046	0.0046	0.0046	0.0092	0.0138
Mid-span-0	0	0.0000	0.0000	0.0000	0.0000	0.0000	0.0000	0.0064	0.0064	0.0064	0.0086	0.0150	0.0129	0.0129
mid-span-1	0	0.0000	0.0067	0.0067	0.0067	0.0111	0.0156	0.0134	0.0134	0.0201	0.0201	0.0201	0.0201	0.0268
mid-span-2	0	0.0011	0.0000	0.0000	0.0000	0.0011	0.0000	0.0000	0.0000	0.0000	0.0000	0.0000	0.0011	0.0000
mid-span-4	0	0.0000	0.0022	0.0044	0.0067	0.0078	0.0111	0.0133	0.0133	0.0167	0.0189	0.0211	0.0222	0.0245
mid-span-5	0	0.0022	0.0022	0.0043	0.0043	0.0043	0.0130	0.0108	0.0130	0.0108	0.0195	0.0195	0.0173	0.0238
bqp-1	0	0.0000	0.0000	0.0000	0.0000	0.0000	0.0000	0.0000	0.0000	0.0000	0.0000	0.0000	0.0000	0.0000
BQP-2	0	N/A	N/A	N/A	N/A	N/A	N/A	N/A	N/A	N/A	N/A	N/A	N/A	N/A
BQP-3	0	0.0000	0.0092	0.0092	0.0092	0.0092	0.0138	0.0138	0.0138	0.0183	0.0183	0.0229	0.0275	0.0275
BQP-4	0	0.0046	0.0046	0.0046	0.0046	0.0046	0.0046	0.0046	0.0091	0.0091	0.0137	0.0182	0.0182	0.0182
BQP-5	0	0.0000	0.0000	0.0065	0.0065	0.0065	0.0130	0.0130	0.0130	0.0130	0.0195	0.0216	0.0195	0.0259

Concentrated Load at Bottom Quarter Point Continued.

Strain Gage	Load in lbs.														
	8004.9	8489.3	8990.1	9564.8	10082	10500	11075	11494	11978	12454	12931	13349	13932	14334	14811
QPT-1	24.24	26.17	27.14	29.08	31.02	32.96	34.90	35.87	37.81	39.75	41.69	42.66	44.59	46.53	47.50
QPT-2	30.06	32.00	33.94	36.85	39.75	41.69	44.60	46.54	48.48	51.39	53.33	56.24	58.18	60.12	63.03
QPT-3	30.07	32.01	33.95	36.86	39.77	41.71	43.65	45.59	48.50	51.41	53.36	56.27	58.21	60.15	63.06
QPT-4	30.06	32.00	34.91	37.82	39.76	42.67	44.61	47.52	49.46	52.37	55.28	57.22	60.12	62.06	64.97
QPT-5	32.00	33.94	36.85	39.76	41.70	43.64	46.55	48.49	51.40	53.34	56.25	58.19	61.10	63.03	64.97
QPT-6	24.23	26.17	28.11	30.05	31.99	32.96	34.89	36.83	38.77	40.71	41.68	43.62	45.56	46.53	48.47
MS-1	43.62	46.53	49.44	53.32	57.20	59.13	63.01	65.92	68.83	71.74	75.62	78.52	82.40	85.31	88.22
MS-2	42.68	45.60	48.51	51.42	54.33	57.24	61.12	63.06	65.97	68.88	71.79	74.70	77.61	79.55	82.46
MS-3	-10.32	-10.91	-11.50	-12.39	-13.27	-13.57	-14.45	-14.75	-15.63	-16.22	-16.81	-17.11	-17.99	-18.29	-18.88
MS-4	33.01	34.95	36.89	38.84	41.75	42.72	45.63	46.60	48.54	50.49	52.43	53.40	56.31	57.28	59.22
MS-5	47.54	50.45	54.33	57.24	61.12	64.04	67.92	70.83	73.74	76.65	80.53	83.44	86.35	89.26	92.18
MS-6	39.77	41.71	44.62	48.50	51.41	53.35	56.26	59.17	62.08	64.99	67.90	70.81	73.72	75.66	79.54
QPB-1	48.56	52.44	55.35	59.24	63.12	66.04	70.89	73.81	77.69	80.60	85.46	89.35	94.20	98.09	102.94
QPB-2	N/A	N/A	N/A	N/A	N/A	N/A	N/A	N/A	N/A	N/A	N/A	N/A	N/A	N/A	N/A
QPB-3	133.87	142.60	152.31	162.98	173.65	182.39	192.09	196.94	205.68	216.35	226.05	221.20	231.88	240.61	242.55
QPB-4	137.74	147.45	157.15	168.79	179.46	188.20	204.69	215.37	226.04	229.92	236.71	248.36	262.92	273.59	286.21
QPB-5	97.09	103.88	110.68	118.44	126.21	131.07	140.78	146.60	154.37	161.17	168.94	176.71	186.42	194.19	204.87
QPB-6	48.38	51.34	54.31	57.27	61.22	64.18	69.12	72.08	75.04	78.99	82.94	86.89	90.84	94.79	99.73
Displacement															
TQP-0	0.0129	0.0129	0.0129	0.0129	0.0194	0.0194	0.0194	0.0194	0.0194	0.0194	0.0259	0.0259	0.0259	0.0259	0.0259
tqp-1	0.0065	0.0065	0.0130	0.0130	0.0152	0.0152	0.0152	0.0152	0.0217	0.0217	0.0217	0.0217	0.0217	0.0282	0.0282
tqp-2	0.0177	0.0188	0.0199	0.0210	0.0221	0.0221	0.0243	0.0254	0.0265	0.0276	0.0298	0.0321	0.0343	0.0354	0.0376
tqp-3	0.0065	0.0086	0.0086	0.0086	0.0086	0.0129	0.0151	0.0151	0.0151	0.0151	0.0215	0.0215	0.0215	0.0215	0.0237
tqp-4	0.0129	0.0151	0.0161	0.0183	0.0194	0.0205	0.0226	0.0237	0.0248	0.0280	0.0291	0.0312	0.0323	0.0334	0.0345
TQP-5	0.0092	0.0138	0.0138	0.0183	0.0183	0.0183	0.0183	0.0183	0.0229	0.0229	0.0229	0.0229	0.0321	0.0321	0.0321
Mid-span-0	0.0129	0.0193	0.0193	0.0193	0.0279	0.0279	0.0258	0.0279	0.0300	0.0343	0.0343	0.0343	0.0408	0.0408	0.0408
mid-span-1	0.0268	0.0268	0.0268	0.0357	0.0334	0.0334	0.0357	0.0424	0.0401	0.0424	0.0468	0.0468	0.0468	0.0468	0.0557
mid-span-2	0.0011	0.0000	0.0000	0.0000	0.0000	0.0000	0.0000	0.0000	0.0000	0.0000	0.0000	0.0000	0.0000	0.0000	0.0000
mid-span-4	0.0267	0.0289	0.0311	0.0322	0.0345	0.0356	0.0389	0.0400	0.0423	0.0434	0.0467	0.0489	0.0500	0.0512	0.0545
mid-span-5	0.0238	0.0260	0.0260	0.0325	0.0325	0.0325	0.0346	0.0390	0.0390	0.0390	0.0455	0.0455	0.0455	0.0455	0.0519
bqp-1	0.0000	0.0000	0.0000	0.0000	0.0000	0.0000	0.0000	0.0000	0.0000	0.0000	0.0000	0.0000	0.0000	0.0000	0.0000
BQP-2	N/A	N/A	N/A	N/A	N/A	N/A	N/A	N/A	N/A	N/A	N/A	N/A	N/A	N/A	N/A
BQP-3	0.0275	0.0367	0.0367	0.0321	0.0413	0.0413	0.0413	0.0413	0.0505	0.0459	0.0505	0.0550	0.0550	0.0550	0.0642
BQP-4	0.0182	0.0228	0.0228	0.0228	0.0319	0.0319	0.0319	0.0319	0.0364	0.0364	0.0364	0.0455	0.0455	0.0455	0.0455
BQP-5	0.0259	0.0259	0.0281	0.0324	0.0346	0.0346	0.0324	0.0411	0.0411	0.0411	0.0411	0.0475	0.0475	0.0475	0.0540

Slab: XOREX-25

Test: Concentrated Load at Mid-Span (Figure 5.3-B)

Strain Gage Readings are in $\mu\text{in}/\text{in}$.

Deflection readings are in inches.

		Load in lbs.										
Strain Gage	0	706.07	1321.8	2134.6	2561.5	3013.1	3579.6	4080.4	4688	5123.1	5509	5977
QPT-1	0	3.9	7.8	13.6	16.5	19.4	23.3	27.1	31.0	34.9	36.8	40.7
QPT-2	0	5.8	10.7	18.4	22.3	27.1	33.9	39.8	46.5	50.4	55.3	61.1
QPT-3	0	4.9	10.7	18.4	22.3	27.2	33.0	38.8	46.6	51.4	56.3	62.1
QPT-4	0	4.8	9.7	18.4	22.3	27.2	33.9	39.8	47.5	52.4	58.2	64.0
QPT-5	0	5.8	10.7	19.4	23.3	28.1	33.9	39.8	46.5	51.4	56.2	61.1
QPT-6	0	3.9	7.8	12.6	15.5	19.4	23.3	26.2	31.0	33.9	36.8	40.7
MS-1	0	5.8	10.7	18.4	22.3	26.2	32.0	36.8	41.7	46.5	50.4	54.3
MS-2	0	7.8	14.6	25.2	30.1	35.9	42.7	48.5	56.3	62.1	66.9	71.8
MS-3	0	-2.7	-5.0	-8.3	-10.0	-11.8	-14.2	-16.2	-18.6	-20.4	-22.1	-23.9
MS-4	0	8.7	16.5	27.2	33.0	39.8	47.6	54.4	63.1	68.9	73.8	80.6
MS-5	0	7.8	15.5	26.2	31.0	37.8	45.6	52.4	60.2	66.0	71.8	77.6
MS-6	0	4.8	9.7	16.5	20.4	24.2	29.1	33.9	38.8	42.7	46.6	50.4
QPB-1	0	3.9	6.8	11.7	14.6	17.5	20.4	23.3	27.2	30.1	33.0	35.0
QPB-2	0	N/A	N/A	N/A	N/A	N/A	N/A	N/A	N/A	N/A	N/A	N/A
QPB-3	0	5.8	10.7	16.5	19.4	23.3	28.1	32.0	35.9	39.8	42.7	46.6
QPB-4	0	4.8	8.7	14.5	17.5	20.4	25.2	28.1	33.0	35.9	38.8	41.7
QPB-5	0	4.9	8.7	15.5	18.4	22.3	26.2	30.1	34.9	38.8	41.7	45.6
QPB-6	0	4.9	7.9	12.8	15.8	19.7	23.7	27.6	31.6	35.5	38.5	41.5
Displacements												
TQP-0	0.0022	0.0022	0.0022	0.0022	0.0043	0.0043	0.0043	0.0108	0.0108	0.0108	0.0129	0.0194
tqp-1	0.0000	0.0000	0.0022	0.0000	0.0000	0.0000	0.0065	0.0065	0.0065	0.0130	0.0130	0.0130
tqp-2	0.0000	0.0000	0.0033	0.0066	0.0088	0.0111	0.0144	0.0166	0.0188	0.0199	0.0221	0.0232
tqp-3	0.0000	0.0000	0.0000	0.0000	0.0000	0.0000	0.0022	0.0043	0.0108	0.0108	0.0108	0.0129
tqp-4	0.0000	0.0000	0.0000	0.0043	0.0065	0.0065	0.0086	0.0097	0.0129	0.0161	0.0183	0.0205
TQP-5	0.0000	0.0000	0.0000	0.0046	0.0046	0.0046	0.0046	0.0046	0.0138	0.0092	0.0092	0.0183
Mid-span-0	0.0000	0.0000	0.0021	0.0000	0.0000	0.0064	0.0064	0.0064	0.0129	0.0129	0.0129	0.0193
mid-span-1	0.0000	0.0000	0.0000	0.0067	0.0089	0.0134	0.0134	0.0134	0.0201	0.0201	0.0201	0.0268
mid-span-2	0.0000	0.0011	0.0000	0.0011	0.0000	0.0011	0.0000	0.0011	0.0011	0.0011	0.0011	0.0011
mid-span-4	0.0000	0.0011	0.0044	0.0089	0.0111	0.0133	0.0167	0.0189	0.0222	0.0245	0.0278	0.0311
mid-span-5	0.0022	0.0022	0.0022	0.0043	0.0065	0.0108	0.0108	0.0108	0.0173	0.0173	0.0260	0.0260
bqp-1	0.0011	0.0011	0.0011	0.0011	0.0011	0.0011	0.0000	0.0011	0.0011	0.0011	0.0011	0.0011
BQP-2	N/A	N/A	N/A	N/A	N/A	N/A	N/A	N/A	N/A	N/A	N/A	N/A
BQP-3	0.0000	0.0000	0.0000	0.0092	0.0092	0.0092	0.0092	0.0138	0.0138	0.0229	0.0229	0.0229
BQP-4	0.0000	0.0000	0.0000	0.0000	0.0000	0.0091	0.0091	0.0091	0.0137	0.0137	0.0137	0.0182
BQP-5	0.0000	0.0022	0.0022	0.0043	0.0065	0.0065	0.0130	0.0130	0.0130	0.0195	0.0195	0.0195

Concentrated Load at Mid-Span Continued.

Strain Gage	6609.1	7036.1	7520.5	8021.3	8546.7	9269.2	9507.3	9991.7
QPT-1	45.6	48.5	52.4	56.2	60.1	65.0	66.9	70.8
QPT-2	68.8	73.7	79.5	85.3	91.2	99.9	102.8	107.6
QPT-3	69.8	75.7	81.5	88.3	95.1	102.8	105.7	111.6
QPT-4	71.8	78.6	84.4	92.1	98.9	107.6	110.6	117.3
QPT-5	68.9	73.7	79.5	85.3	92.1	99.9	102.8	108.6
QPT-6	44.6	48.5	52.3	56.2	60.1	64.9	66.9	70.8
MS-1	60.1	65.0	69.8	74.6	80.5	88.2	91.1	97.9
MS-2	80.5	85.4	92.2	99.0	105.7	114.5	117.4	125.2
MS-3	-26.2	-28.3	-30.4	-32.7	-34.8	-38.3	-39.5	-41.0
MS-4	89.3	95.2	101.0	107.8	115.5	124.3	127.2	129.1
MS-5	86.4	92.2	99.0	106.7	114.5	129.0	135.8	149.4
MS-6	56.3	60.1	64.0	68.9	73.7	81.5	83.4	89.2
QPB-1	38.8	41.8	44.7	48.6	51.5	57.3	59.2	63.1
QPB-2	N/A	N/A	N/A	N/A	N/A	N/A	N/A	N/A
QPB-3	51.4	54.3	58.2	61.1	65.0	70.8	71.8	73.7
QPB-4	46.6	49.5	53.3	56.3	60.1	65.0	66.0	68.9
QPB-5	50.5	55.3	59.2	63.1	67.0	70.9	71.8	76.7
QPB-6	45.4	49.4	52.3	57.3	61.2	66.1	67.1	71.1
Displacements								
TQP-0	0.0172	0.0172	0.0259	0.0259	0.0237	0.0323	0.0323	0.0323
tqp-1	0.0195	0.0195	0.0217	0.0195	0.0282	0.0282	0.0261	0.0347
tqp-2	0.0265	0.0276	0.0309	0.0332	0.0365	0.0409	0.0420	0.0431
tqp-3	0.0172	0.0172	0.0237	0.0237	0.0237	0.0301	0.0301	0.0301
tqp-4	0.0226	0.0248	0.0280	0.0312	0.0334	0.0355	0.0366	0.0388
TQP-5	0.0183	0.0183	0.0229	0.0229	0.0229	0.0275	0.0275	0.0321
Mid-span-0	0.0193	0.0258	0.0258	0.0258	0.0322	0.0322	0.0322	0.0386
mid-span-1	0.0268	0.0334	0.0334	0.0334	0.0401	0.0401	0.0401	0.0491
mid-span-2	0.0011	0.0000	0.0000	0.0011	0.0011	0.0000	0.0000	0.0000
mid-span-4	0.0334	0.0356	0.0378	0.0411	0.0434	0.0478	0.0489	0.0523
mid-span-5	0.0260	0.0325	0.0325	0.0390	0.0390	0.0455	0.0455	0.0455
bqp-1	0.0011	0.0011	0.0011	0.0011	0.0011	0.0011	0.0011	0.0011
BQP-2	N/A	N/A	N/A	N/A	N/A	N/A	N/A	N/A
BQP-3	0.0275	0.0275	0.0275	0.0275	0.0367	0.0367	0.0367	0.0413
BQP-4	0.0228	0.0228	0.0273	0.0273	0.0273	0.0364	0.0364	0.0364
BQP-5	0.0281	0.0259	0.0259	0.0259	0.0324	0.0324	0.0324	0.0389

Slab: XOREX-25

Test: Concentrated Load at Top Quarter Point (Figure 5.3-C)

Strain Gage Readings are in $\mu\text{in/in}$.

Displacement Readings are in inches.

Strain Gage	Load in lbs.												
	0	459.77	1247.9	1970.4	2471.2	3054.1	4088.6	4737.2	4983.5	5467.9	6116.5	6453.2	6945.8
QPT-1	0	1.9	6.8	10.7	13.6	16.5	22.3	26.2	28.1	31.0	34.9	36.8	39.7
QPT-2	0	4.8	12.6	20.4	25.2	31.0	42.7	49.4	52.4	58.2	65.0	68.8	74.7
QPT-3	0	4.8	15.5	25.2	31.0	38.8	53.4	63.1	66.0	73.7	82.5	87.3	95.1
QPT-4	0	4.8	13.6	21.3	27.1	33.9	46.5	55.3	58.2	65.0	72.7	77.6	84.4
QPT-5	0	3.9	10.7	16.5	21.3	26.2	34.9	41.7	43.6	48.5	53.3	57.2	61.1
QPT-6	0	1.9	6.8	10.7	13.6	16.5	23.3	27.1	28.1	31.0	34.9	37.8	40.7
MS-1	0	2.9	6.8	9.7	12.6	15.5	21.3	25.2	26.2	29.1	33.0	34.9	37.8
MS-2	0	2.9	6.8	10.7	13.6	16.5	22.3	25.2	27.2	30.1	33.0	34.9	37.8
MS-3	0	-0.6	-1.5	-2.7	-3.2	-3.8	-5.6	-6.5	-6.8	-7.4	-8.6	-8.8	-9.7
MS-4	0	1.9	4.9	8.7	10.7	13.6	17.5	21.4	22.3	24.3	27.2	29.1	31.1
MS-5	0	1.9	5.8	9.7	12.6	16.5	22.3	26.2	27.2	30.1	33.0	34.9	37.8
MS-6	0	1.9	5.8	9.7	11.6	14.5	19.4	23.3	24.2	27.2	30.1	32.0	34.9
QPB-1	0	1.0	2.9	4.9	6.8	7.8	10.7	12.6	13.6	14.6	16.5	17.5	18.4
QPB-2	0	N/A	N/A	N/A	N/A	N/A	N/A	N/A	N/A	N/A	N/A	N/A	N/A
QPB-3	0	1.0	3.9	5.8	6.8	8.7	12.6	14.5	15.5	17.5	19.4	20.4	22.3
QPB-4	0	1.0	2.9	4.8	5.8	7.8	10.7	12.6	12.6	14.5	16.5	17.5	19.4
QPB-5	0	1.0	3.9	5.8	6.8	8.7	11.6	14.6	14.6	16.5	18.4	19.4	21.4
QPB-6	0	-3.0	-2.0	-3.0	-7.9	-8.9	-9.9	-9.9	-9.9	-7.9	-6.9	-5.9	-4.9
Displacement													
TQP-0	0.0000	0.0000	0.0000	0.0000	0.0065	0.0086	0.0065	0.0151	0.0151	0.0151	0.0151	0.0151	0.0216
tqp-1	0.0000	0.0000	0.0000	0.0000	0.0000	0.0000	0.0087	0.0065	0.0087	0.0130	0.0152	0.0152	0.0152
tqp-2	0.0000	0.0000	0.0022	0.0033	0.0055	0.0088	0.0122	0.0155	0.0166	0.0188	0.0210	0.0221	0.0243
tqp-3	0.0000	0.0000	0.0000	0.0000	0.0022	0.0022	0.0022	0.0000	0.0000	0.0065	0.0065	0.0065	0.0065
tqp-4	0.0000	0.0000	0.0011	0.0000	0.0011	0.0065	0.0108	0.0118	0.0118	0.0129	0.0140	0.0151	0.0172
TQP-5	0.0046	0.0046	0.0046	0.0000	0.0046	0.0046	0.0046	0.0046	0.0046	0.0138	0.0138	0.0138	0.0183
Mid-span-0	0.0021	0.0021	0.0021	0.0043	0.0021	0.0021	0.0043	0.0043	0.0043	0.0021	0.0107	0.0107	0.0086
mid-span-1	0.0000	0.0022	0.0022	0.0067	0.0067	0.0067	0.0156	0.0156	0.0156	0.0134	0.0201	0.0201	0.0223
mid-span-2	0.0000	0.0011	0.0011	0.0000	0.0000	0.0000	0.0011	0.0011	0.0011	0.0022	0.0000	0.0000	0.0011
mid-span-4	0.0000	0.0000	0.0011	0.0033	0.0056	0.0067	0.0111	0.0133	0.0145	0.0156	0.0178	0.0189	0.0211
mid-span-5	0.0022	0.0022	0.0043	0.0043	0.0043	0.0043	0.0108	0.0108	0.0108	0.0108	0.0173	0.0173	0.0195
bqp-1	0.0000	0.0000	0.0000	0.0000	0.0000	0.0000	0.0000	0.0000	0.0000	0.0000	0.0000	0.0000	0.0011
BQP-2	N/A	N/A	N/A	N/A	N/A	N/A	N/A	N/A	N/A	N/A	N/A	N/A	N/A
BQP-3	0.0046	0.0046	0.0046	0.0046	0.0046	0.0046	0.0046	0.0046	0.0046	0.0138	0.0092	0.0092	0.0092
BQP-4	0.0000	0.0000	0.0000	0.0000	0.0000	0.0000	0.0000	0.0000	0.0000	0.0000	0.0000	0.0000	0.0091
BQP-5	0.0000	0.0000	0.0022	0.0000	0.0065	0.0065	0.0065	0.0065	0.0130	0.0130	0.0130	0.0130	0.0130

Test: Concentrated Load at Top Quarter Point Continued

Strain Gage	Load in lbs.														
	7463	8111.6	8587.8	9499.1	10106	10607	11231	11683	12151	12643	13029	13448	13883	14351	14934
QPT-1	43.6	47.5	50.4	57.2	62.0	65.9	70.8	74.6	78.5	82.4	87.3	92.1	96.0	101.8	110.5
QPT-2	80.5	87.3	97.9	115.4	129.9	141.6	153.2	163.9	174.5	186.2	197.8	209.5	224.0	242.4	268.6
QPT-3	104.8	115.4	124.2	161.0	191.1	199.9	216.4	233.8	248.4	262.9	258.1	267.8	281.4	286.2	309.5
QPT-4	91.2	98.9	103.8	109.6	111.5	145.5	169.7	223.1	251.2	277.4	302.6	310.4	315.2	342.4	344.3
QPT-5	65.9	72.7	76.6	85.3	98.9	112.5	145.5	162.9	172.6	179.4	186.2	199.8	214.3	236.6	263.8
QPT-6	44.6	48.5	52.3	58.2	64.0	67.9	73.7	77.5	81.4	86.3	91.1	96.0	100.8	105.7	112.4
MS-1	40.7	44.6	47.5	53.3	57.2	60.1	64.0	67.9	70.8	74.6	77.6	81.4	84.3	88.2	93.1
MS-2	40.7	43.7	45.6	49.5	53.4	55.3	58.2	61.1	63.1	65.0	66.9	66.9	68.9	70.8	73.7
MS-3	-10.3	-11.2	-11.8	-13.0	-13.6	-14.2	-15.0	-15.3	-16.2	-16.5	-16.8	-17.4	-17.7	-18.3	-18.6
MS-4	34.0	36.9	38.8	42.7	44.7	46.6	48.5	51.5	52.4	54.4	55.3	56.3	57.3	59.2	60.2
MS-5	39.8	43.7	45.6	49.5	50.4	52.4	55.3	58.2	60.2	63.1	66.0	67.9	71.8	75.7	80.5
MS-6	37.8	40.7	43.6	48.5	52.4	55.3	59.2	62.1	65.0	68.9	70.8	74.7	77.6	80.5	84.4
QPB-1	20.4	22.3	23.3	26.2	28.2	30.1	32.0	33.0	34.0	35.9	36.9	38.8	39.8	41.8	43.7
QPB-2	N/A	N/A	N/A	N/A	N/A	N/A	N/A	N/A	N/A	N/A	N/A	N/A	N/A	N/A	N/A
QPB-3	23.3	26.2	27.2	30.1	32.0	33.9	35.9	36.9	38.8	39.8	40.7	41.7	42.7	43.6	45.6
QPB-4	21.3	23.3	24.2	27.2	29.1	30.1	32.0	33.9	34.9	36.9	37.8	38.8	39.8	41.7	42.7
QPB-5	22.3	24.3	25.2	28.2	31.1	32.0	34.0	35.9	36.9	38.8	41.7	43.7	44.7	46.6	48.5
QPB-6	-3.9	-2.0	0.0	3.0	5.9	6.9	9.9	10.9	12.8	14.8	15.8	17.8	18.8	18.8	19.7
Displacement															
TQP-0	0.0216	0.0237	0.0237	0.0302	0.0302	0.0302	0.0366	0.0366	0.0366	0.0366	0.0431	0.0431	0.0431	0.0453	0.0517
tqp-1	0.0195	0.0217	0.0217	0.0261	0.0304	0.0304	0.0326	0.0369	0.0369	0.0369	0.0369	0.0456	0.0456	0.0434	0.0521
tqp-2	0.0254	0.0276	0.0298	0.0321	0.0365	0.0387	0.0420	0.0453	0.0475	0.0486	0.0508	0.0542	0.0564	0.0597	0.0630
tqp-3	0.0129	0.0129	0.0129	0.0194	0.0194	0.0258	0.0258	0.0280	0.0323	0.0323	0.0344	0.0387	0.0387	0.0452	0.0452
tqp-4	0.0194	0.0237	0.0248	0.0280	0.0312	0.0334	0.0366	0.0388	0.0398	0.0409	0.0431	0.0441	0.0452	0.0484	0.0506
TQP-5	0.0183	0.0183	0.0183	0.0275	0.0275	0.0321	0.0321	0.0321	0.0321	0.0367	0.0367	0.0367	0.0459	0.0459	0.0459
Mid-span-0	0.0107	0.0172	0.0150	0.0172	0.0236	0.0236	0.0236	0.0300	0.0300	0.0300	0.0300	0.0365	0.0365	0.0365	0.0429
mid-span-1	0.0201	0.0290	0.0290	0.0290	0.0357	0.0334	0.0357	0.0424	0.0424	0.0424	0.0513	0.0491	0.0491	0.0513	0.0557
mid-span-2	0.0022	0.0011	0.0011	0.0011	0.0022	0.0011	0.0011	0.0011	0.0022	0.0022	0.0022	0.0022	0.0022	0.0022	0.0022
mid-span-4	0.0234	0.0256	0.0278	0.0300	0.0334	0.0356	0.0378	0.0400	0.0411	0.0434	0.0456	0.0478	0.0489	0.0512	0.0545
mid-span-5	0.0173	0.0238	0.0260	0.0260	0.0303	0.0303	0.0368	0.0368	0.0390	0.0411	0.0433	0.0455	0.0455	0.0519	0.0519
bqp-1	0.0011	0.0000	0.0000	0.0000	0.0000	0.0000	0.0000	0.0011	0.0011	0.0000	0.0011	0.0011	0.0000	0.0011	0.0011
BQP-2	N/A	N/A	N/A	N/A	N/A	N/A	N/A	N/A	N/A	N/A	N/A	N/A	N/A	N/A	N/A
BQP-3	0.0092	0.0183	0.0183	0.0183	0.0183	0.0229	0.0275	0.0275	0.0275	0.0275	0.0321	0.0321	0.0321	0.0321	0.0367
BQP-4	0.0091	0.0091	0.0091	0.0137	0.0137	0.0137	0.0137	0.0228	0.0228	0.0228	0.0228	0.0228	0.0273	0.0273	0.0273
BQP-5	0.0130	0.0173	0.0195	0.0195	0.0259	0.0238	0.0238	0.0238	0.0259	0.0324	0.0324	0.0324	0.0303	0.0324	0.0389

Slab: XOREX-25

Test: Concentrated Load at Top Third Point (Figure 5.3-D)

Strain Gage Readings are in $\mu\text{in/in}$.

Displacement Readings are in inches.

Strain Gage	Load in lbs.													
	0	566.5	1280.7	1502.4	1995	2857.1	3522.1	4121.5	4507.3	5114.9	5615.7	5985.2	6510.6	7068.9
QPT-1	0	3.9	7.8	9.7	13.6	19.4	24.2	28.1	31.0	35.9	38.8	41.7	45.6	50.4
QPT-2	0	5.8	14.5	17.5	24.2	35.9	46.5	56.2	62.1	71.8	79.5	85.3	94.1	102.8
QPT-3	0	6.8	17.5	20.4	28.1	41.7	53.4	64.0	70.8	81.5	90.2	97.0	106.7	117.4
QPT-4	0	6.8	17.5	20.4	29.1	43.6	56.2	67.9	75.6	88.3	97.9	105.7	116.4	128.0
QPT-5	0	5.8	14.5	16.5	23.3	34.9	43.6	53.3	58.2	66.9	74.7	80.5	88.3	96.0
QPT-6	0	2.9	7.8	9.7	12.6	19.4	24.2	28.1	31.0	35.9	39.7	42.6	46.5	50.4
MS-1	0	3.9	8.7	10.7	13.6	19.4	24.2	29.1	31.0	35.9	39.7	42.7	46.5	50.4
MS-2	0	4.9	9.7	11.6	15.5	21.3	26.2	31.0	34.0	38.8	41.7	45.6	49.5	53.4
MS-3	0	-1.2	-2.4	-2.9	-3.8	-5.3	-6.8	-8.0	-8.6	-9.7	-10.9	-11.5	-12.4	-13.6
MS-4	0	2.9	7.8	8.7	12.6	17.5	22.3	26.2	28.2	32.0	35.0	37.9	40.8	43.7
MS-5	0	3.9	9.7	11.6	15.5	21.3	27.2	32.0	34.9	39.8	43.7	46.6	50.4	55.3
MS-6	0	3.9	8.7	9.7	12.6	18.4	22.3	27.2	29.1	33.0	36.9	38.8	42.7	46.6
QPB-1	0	1.9	4.9	5.8	7.8	10.7	12.6	15.5	16.5	18.4	20.4	22.3	24.3	26.2
QPB-2	0	N/A	N/A	N/A	N/A	N/A	N/A	N/A	N/A	N/A	N/A	N/A	N/A	N/A
QPB-3	0	2.9	5.8	6.8	8.7	11.6	14.5	17.5	18.4	21.3	23.3	25.2	27.2	29.1
QPB-4	0	1.9	5.8	5.8	8.7	11.6	14.5	16.5	18.4	21.3	23.3	25.2	27.2	29.1
QPB-5	0	1.9	5.8	5.8	7.8	11.6	14.6	16.5	18.4	21.4	23.3	24.3	27.2	29.1
QPB-6	0	3.9	6.9	9.9	11.8	16.8	19.7	23.7	25.7	28.6	30.6	35.5	37.5	41.5
Displacement														
TQP-0	0.0022	0.0000	0.0065	0.0065	0.0043	0.0108	0.0129	0.0129	0.0129	0.0172	0.0194	0.0194	0.0194	0.0259
tqp-1	0.0022	0.0022	0.0000	0.0022	0.0022	0.0022	0.0000	0.0065	0.0065	0.0065	0.0109	0.0130	0.0130	0.0130
tqp-2	0.0000	0.0011	0.0033	0.0044	0.0055	0.0099	0.0133	0.0166	0.0177	0.0199	0.0210	0.0221	0.0254	0.0276
tqp-3	0.0000	0.0000	0.0000	0.0000	0.0000	0.0022	0.0065	0.0065	0.0065	0.0129	0.0129	0.0129	0.0194	0.0194
tqp-4	0.0011	0.0000	0.0000	0.0000	0.0043	0.0075	0.0086	0.0097	0.0108	0.0140	0.0172	0.0194	0.0215	0.0237
TQP-5	0.0000	0.0000	0.0000	0.0000	0.0000	0.0000	0.0092	0.0092	0.0092	0.0138	0.0138	0.0138	0.0183	0.0229
Mid-span-0	0.0000	0.0000	0.0000	0.0000	0.0000	0.0000	0.0000	0.0064	0.0064	0.0064	0.0107	0.0129	0.0150	0.0150
mid-span-1	0.0022	0.0045	0.0067	0.0045	0.0067	0.0134	0.0134	0.0201	0.0201	0.0201	0.0268	0.0268	0.0268	0.0268
mid-span-2	0.0000	0.0000	0.0011	0.0000	0.0000	0.0011	0.0011	0.0011	0.0011	0.0000	0.0011	0.0011	0.0011	0.0000
mid-span-4	0.0000	0.0000	0.0022	0.0033	0.0056	0.0100	0.0122	0.0145	0.0167	0.0189	0.0211	0.0222	0.0256	0.0278
mid-span-5	0.0022	0.0022	0.0022	0.0022	0.0022	0.0065	0.0065	0.0130	0.0108	0.0108	0.0195	0.0173	0.0173	0.0238
bqp-1	0.0000	0.0000	0.0011	0.0000	0.0000	0.0000	0.0011	0.0011	0.0011	0.0011	0.0011	0.0011	0.0011	0.0011
BQP-2	N/A	N/A	N/A	N/A	N/A	N/A	N/A	N/A	N/A	N/A	N/A	N/A	N/A	N/A
BQP-3	0.0000	0.0000	0.0000	0.0000	0.0000	0.0000	0.0092	0.0092	0.0092	0.0092	0.0138	0.0138	0.0138	0.0138
BQP-4	0.0000	0.0000	0.0000	0.0000	0.0000	0.0000	0.0000	0.0000	0.0091	0.0091	0.0091	0.0091	0.0137	0.0137
BQP-5	0.0022	0.0022	0.0022	0.0022	0.0022	0.0022	0.0086	0.0086	0.0086	0.0086	0.0151	0.0151	0.0151	0.0151

Concentrated Load at Top Third Point Continued.

Strain Gage	Load in lbs.										
	7569.7	8087	8530.3	9113.3	9646.9	10147	10591	11157	11798	12479	13054
QPT-1	53.3	57.2	61.1	65.0	69.8	73.7	76.6	81.4	87.3	93.1	99.9
QPT-2	110.5	119.3	127.0	136.7	145.5	154.2	161.9	170.7	181.3	193.0	205.6
QPT-3	126.1	135.8	144.6	155.2	165.9	174.6	183.4	193.1	203.8	216.4	230.9
QPT-4	137.7	148.4	158.1	169.7	180.4	191.1	200.8	212.4	227.0	241.5	258.0
QPT-5	103.8	111.5	118.3	127.0	134.8	142.6	149.4	159.1	169.7	182.3	195.0
QPT-6	54.3	58.2	62.0	66.9	70.8	74.6	78.5	83.4	88.2	95.0	100.8
MS-1	54.3	57.2	61.1	65.0	69.8	72.7	75.6	80.5	85.3	91.1	97.9
MS-2	57.2	61.1	64.0	68.9	72.8	76.6	79.6	84.4	89.3	94.1	99.0
MS-3	-14.5	-15.6	-16.2	-17.4	-18.3	-19.5	-20.4	-21.2	-21.8	-23.0	-23.3
MS-4	47.6	50.5	53.4	56.3	60.2	63.1	66.0	69.9	73.8	77.7	78.6
MS-5	59.2	63.1	66.9	71.8	76.6	80.5	85.4	91.2	107.7	119.3	129.0
MS-6	49.5	53.4	56.3	60.1	64.0	67.9	70.8	74.7	79.5	85.4	91.2
QPB-1	28.2	30.1	32.0	34.0	35.9	37.9	39.8	41.8	44.7	47.6	50.5
QPB-2	N/A	N/A	N/A	N/A	N/A	N/A	N/A	N/A	N/A	N/A	N/A
QPB-3	32.0	33.9	35.9	37.8	40.7	42.7	44.6	46.6	48.5	51.4	53.3
QPB-4	31.0	33.0	34.9	36.9	39.8	40.7	42.7	45.6	47.5	50.4	52.4
QPB-5	31.1	34.0	35.9	37.9	40.8	42.7	44.7	47.6	51.5	55.3	59.2
QPB-6	44.4	47.4	50.3	53.3	55.3	58.2	61.2	64.2	68.1	72.1	75.0
Displacement											
TQP-0	0.0259	0.0259	0.0259	0.0323	0.0323	0.0323	0.0388	0.0388	0.0388	0.0474	0.0474
tqp-1	0.0195	0.0195	0.0217	0.0239	0.0282	0.0282	0.0282	0.0347	0.0347	0.0347	0.0413
tqp-2	0.0298	0.0332	0.0354	0.0387	0.0409	0.0431	0.0442	0.0464	0.0486	0.0531	0.0564
tqp-3	0.0194	0.0258	0.0258	0.0258	0.0323	0.0323	0.0323	0.0387	0.0387	0.0452	0.0452
tqp-4	0.0248	0.0280	0.0301	0.0334	0.0355	0.0366	0.0388	0.0398	0.0420	0.0441	0.0474
TQP-5	0.0229	0.0229	0.0275	0.0275	0.0275	0.0367	0.0367	0.0367	0.0413	0.0413	0.0413
Mid-span-0	0.0193	0.0193	0.0193	0.0258	0.0258	0.0258	0.0343	0.0343	0.0343	0.0408	0.0386
mid-span-1	0.0334	0.0334	0.0334	0.0401	0.0401	0.0401	0.0468	0.0468	0.0491	0.0535	0.0535
mid-span-2	0.0011	0.0011	0.0011	0.0011	0.0011	0.0022	0.0011	0.0011	0.0011	0.0011	0.0000
mid-span-4	0.0300	0.0322	0.0345	0.0367	0.0389	0.0411	0.0434	0.0456	0.0478	0.0512	0.0545
mid-span-5	0.0238	0.0238	0.0281	0.0325	0.0325	0.0390	0.0390	0.0390	0.0455	0.0455	0.0498
bqp-1	0.0011	0.0011	0.0011	0.0000	0.0011	0.0011	0.0011	0.0011	0.0011	0.0011	0.0011
BQP-2	N/A	N/A	N/A	N/A	N/A	N/A	N/A	N/A	N/A	N/A	N/A
BQP-3	0.0229	0.0229	0.0229	0.0229	0.0275	0.0275	0.0275	0.0275	0.0321	0.0321	0.0367
BQP-4	0.0137	0.0137	0.0182	0.0228	0.0228	0.0228	0.0273	0.0273	0.0273	0.0273	0.0364
BQP-5	0.0216	0.0216	0.0216	0.0216	0.0281	0.0281	0.0281	0.0281	0.0346	0.0346	0.0346

Slab: XOREX-25

Test: Concentrated Load at Bottom Third Point (Figure 5.3-E)

Strain Gage Readings are in $\mu\text{in}/\text{in}$.

Displacement Readings are in inches.

Strain Gage	Load in lbs.											
	0	747.12	1420.3	2175.6	2545.1	3054.1	3653.5	4351.3	5032.8	5509	5985.2	6559.9
QPT-1	0	2.9	4.8	7.8	9.7	11.6	14.5	17.4	19.4	21.3	23.3	26.2
QPT-2	0	2.9	6.8	10.7	12.6	14.5	18.4	22.3	26.2	29.1	31.0	34.9
QPT-3	0	2.9	6.8	10.7	12.6	14.6	18.4	22.3	26.2	28.1	31.0	34.9
QPT-4	0	2.9	5.8	9.7	11.6	14.5	17.5	21.3	25.2	28.1	32.0	34.9
QPT-5	0	3.9	6.8	10.7	12.6	15.5	19.4	23.3	27.2	30.1	33.0	36.9
QPT-6	0	2.9	5.8	8.7	10.7	12.6	14.5	17.4	21.3	23.3	25.2	27.1
MS-1	0	4.8	9.7	14.5	17.4	20.4	25.2	29.1	33.9	37.8	40.7	44.6
MS-2	0	5.8	10.7	16.5	19.4	23.3	28.1	33.0	38.8	42.7	46.6	50.4
MS-3	0	-1.5	-2.9	-4.4	-5.3	-6.2	-7.4	-8.6	-10.0	-10.9	-11.8	-13.0
MS-4	0	4.9	9.7	14.6	16.5	19.4	23.3	28.2	32.0	35.0	37.9	41.7
MS-5	0	5.8	10.7	16.5	19.4	24.3	29.1	34.9	40.7	45.6	49.5	54.3
MS-6	0	3.9	7.8	12.6	15.5	18.4	22.3	26.2	31.0	33.9	36.9	40.7
QPB-1	0	3.9	7.8	12.6	14.6	17.5	21.4	26.2	30.1	33.0	35.9	39.8
QPB-2	0	N/A	N/A	N/A	N/A	N/A	N/A	N/A	N/A	N/A	N/A	N/A
QPB-3	0	8.7	17.5	26.2	30.1	36.9	43.6	52.4	61.1	66.9	72.7	78.6
QPB-4	0	8.7	16.5	25.2	29.1	34.9	41.7	50.4	58.2	64.0	69.8	76.6
QPB-5	0	6.8	12.6	20.4	24.3	29.1	34.9	41.7	48.5	53.4	58.2	64.1
QPB-6	0	4.9	8.9	12.8	14.8	17.8	21.7	25.7	29.6	32.6	34.6	38.5
Displacement												
TQP-0	0	0.0000	0.0000	0.0000	0.0000	0.0000	0.0065	0.0086	0.0065	0.0065	0.0129	0.0129
tqp-1	0	0.0000	0.0000	0.0000	0.0000	0.0000	0.0000	0.0000	0.0065	0.0065	0.0065	0.0087
tqp-2	0	0.0000	0.0011	0.0044	0.0055	0.0066	0.0088	0.0122	0.0144	0.0155	0.0166	0.0177
tqp-3	0	0.0000	0.0000	0.0000	0.0000	0.0000	0.0000	0.0043	0.0065	0.0065	0.0065	0.0065
tqp-4	0	0.0000	0.0000	0.0011	0.0032	0.0054	0.0065	0.0075	0.0086	0.0097	0.0118	0.0129
TQP-5	0	0.0046	0.0000	0.0000	0.0000	0.0000	0.0000	0.0046	0.0046	0.0046	0.0092	0.0092
Mid-span-0	0	0.0000	0.0000	0.0000	0.0000	0.0000	0.0043	0.0064	0.0086	0.0107	0.0150	0.0150
mid-span-1	0	0.0022	0.0067	0.0067	0.0067	0.0134	0.0134	0.0134	0.0201	0.0201	0.0201	0.0201
mid-span-2	0	0.0000	0.0011	0.0000	0.0000	0.0000	0.0000	0.0011	0.0000	0.0000	0.0000	0.0011
mid-span-4	0	0.0011	0.0033	0.0067	0.0078	0.0111	0.0133	0.0156	0.0189	0.0211	0.0222	0.0256
mid-span-5	0	0.0022	0.0022	0.0043	0.0065	0.0043	0.0108	0.0108	0.0108	0.0195	0.0173	0.0195
bqp-1	0	0.0000	0.0000	0.0000	0.0000	0.0000	0.0000	0.0000	0.0000	0.0000	0.0000	0.0000
BQP-2	0	N/A	N/A	N/A	N/A	N/A	N/A	N/A	N/A	N/A	N/A	N/A
BQP-3	0	0.0000	0.0000	0.0046	0.0092	0.0046	0.0092	0.0138	0.0138	0.0229	0.0229	0.0229
BQP-4	0	0.0000	0.0000	0.0000	0.0000	0.0046	0.0091	0.0091	0.0137	0.0137	0.0137	0.0182
BQP-5	0	0.0000	0.0000	0.0065	0.0065	0.0065	0.0065	0.0130	0.0130	0.0151	0.0195	0.0216

Concentrated Load at Bottom Third Point Continued.

Strain Gage	Load in lbs.													
	7044.3	7520.5	8087	8776.6	9154.3	9663.3	10623	11075	11592	11584	12175	12676	12972	12922
QPT-1	28.1	31.0	33.0	35.9	37.8	39.7	44.6	46.5	49.4	49.4	52.4	54.3	56.2	56.2
QPT-2	38.8	41.7	44.6	49.5	51.4	55.3	61.1	64.0	67.9	67.9	71.8	74.7	76.6	75.6
QPT-3	37.8	41.7	44.6	49.5	51.4	55.3	61.1	65.0	67.9	67.9	71.8	75.7	76.6	76.6
QPT-4	38.8	41.7	45.6	50.4	52.4	56.2	63.0	66.9	70.8	70.8	74.7	77.6	80.5	79.5
QPT-5	39.8	42.7	46.5	51.4	53.3	57.2	63.0	66.9	69.8	69.8	73.7	77.6	79.5	78.6
QPT-6	30.0	32.0	34.9	37.8	39.7	41.7	46.5	48.5	51.4	51.4	54.3	56.2	58.2	58.2
MS-1	48.5	52.3	56.2	61.1	64.0	68.8	76.6	80.5	85.3	85.3	91.1	96.0	99.9	99.9
MS-2	54.3	58.2	63.1	68.9	70.8	75.7	83.4	87.3	91.2	91.2	96.0	100.9	102.8	102.8
MS-3	-13.9	-14.7	-15.9	-17.4	-18.0	-18.9	-20.4	-21.2	-22.1	-22.1	-23.3	-23.9	-24.5	-24.5
MS-4	44.7	47.6	51.5	55.3	57.3	60.2	65.1	68.0	69.9	70.9	72.8	73.8	74.8	73.8
MS-5	59.2	63.1	67.9	74.7	78.6	83.4	92.2	97.0	101.9	100.9	106.7	111.6	115.5	114.5
MS-6	43.6	47.5	50.4	55.3	58.2	62.1	68.9	72.8	76.6	76.6	81.5	86.3	89.2	88.3
QPB-1	42.7	45.6	49.5	54.4	57.3	62.2	69.9	74.8	79.6	79.6	85.5	91.3	96.1	96.1
QPB-2	N/A	N/A	N/A	N/A	N/A	N/A	N/A	N/A	N/A	N/A	N/A	N/A	N/A	N/A
QPB-3	83.4	98.0	111.6	117.4	169.8	183.3	202.8	219.2	233.8	234.8	250.3	260.0	270.7	270.7
QPB-4	82.4	88.3	97.0	103.8	106.7	105.7	146.5	168.8	250.3	251.3	259.0	269.7	269.7	269.7
QPB-5	68.9	73.8	80.6	89.3	94.2	110.7	137.9	147.6	161.2	162.1	176.7	191.3	201.0	201.0
QPB-6	41.5	44.4	48.4	53.3	56.3	61.2	68.1	71.1	75.0	75.0	80.0	83.9	88.9	88.9
Displacement														
TQP-0	0.0129	0.0129	0.0151	0.0216	0.0194	0.0194	0.0280	0.0280	0.0280	0.0280	0.0280	0.0323	0.0345	0.0345
tqp-1	0.0065	0.0152	0.0152	0.0152	0.0152	0.0195	0.0217	0.0217	0.0217	0.0217	0.0282	0.0282	0.0282	0.0282
tqp-2	0.0188	0.0199	0.0210	0.0243	0.0243	0.0265	0.0309	0.0321	0.0343	0.0343	0.0376	0.0398	0.0409	0.0398
tqp-3	0.0129	0.0129	0.0129	0.0194	0.0194	0.0194	0.0215	0.0258	0.0258	0.0258	0.0258	0.0323	0.0323	0.0323
tqp-4	0.0161	0.0183	0.0205	0.0215	0.0226	0.0248	0.0291	0.0312	0.0334	0.0334	0.0345	0.0355	0.0377	0.0377
TQP-5	0.0138	0.0092	0.0183	0.0183	0.0183	0.0183	0.0229	0.0229	0.0229	0.0229	0.0321	0.0321	0.0321	0.0321
Mid-span-0	0.0150	0.0215	0.0215	0.0193	0.0279	0.0279	0.0343	0.0343	0.0343	0.0343	0.0408	0.0408	0.0408	0.0408
mid-span-1	0.0290	0.0268	0.0290	0.0357	0.0334	0.0334	0.0401	0.0424	0.0491	0.0468	0.0468	0.0468	0.0535	0.0535
mid-span-2	0.0011	0.0000	0.0000	0.0000	0.0000	0.0011	0.0011	0.0011	0.0000	0.0000	0.0011	0.0011	0.0000	0.0000
mid-span-4	0.0278	0.0300	0.0322	0.0356	0.0367	0.0389	0.0434	0.0456	0.0478	0.0478	0.0512	0.0534	0.0556	0.0556
mid-span-5	0.0238	0.0238	0.0260	0.0325	0.0325	0.0325	0.0390	0.0390	0.0455	0.0455	0.0476	0.0498	0.0519	0.0519
bqp-1	0.0000	0.0000	0.0000	0.0000	0.0000	0.0000	0.0000	0.0000	0.0000	0.0000	0.0000	0.0000	0.0000	0.0000
BQP-2	N/A	N/A	N/A	N/A	N/A	N/A	N/A	N/A	N/A	N/A	N/A	N/A	N/A	N/A
BQP-3	0.0229	0.0275	0.0275	0.0367	0.0367	0.0367	0.0413	0.0413	0.0459	0.0505	0.0505	0.0505	0.0550	0.0550
BQP-4	0.0228	0.0228	0.0228	0.0273	0.0273	0.0319	0.0364	0.0364	0.0410	0.0410	0.0410	0.0455	0.0501	0.0501
BQP-5	0.0195	0.0281	0.0281	0.0281	0.0346	0.0346	0.0346	0.0411	0.0411	0.0411	0.0411	0.0475	0.0475	0.0475

Slab: XOREX-25

Test: Longitudinal Linear Load along Middle Strip (Figure 5.3-F)

Strain Gage Readings are in $\mu\text{in}/\text{in}$.

Displacement Readings are in inches.

Strain Gage	Load in lbs.										
	0	1346.4	2126.4	3226.6	3981.9	5525.4	6124.7	7709.3	8218.3	9162.5	10139
QPT-1	0	10.7	18.4	32.0	41.7	62.1	71.7	93.1	99.9	113.4	128.0
QPT-2	0	12.6	22.3	38.8	50.4	74.7	84.4	109.6	117.3	132.9	148.4
QPT-3	0	13.6	24.3	40.7	51.4	75.7	85.4	110.6	118.4	133.9	149.4
QPT-4	0	13.6	24.2	41.7	53.3	77.6	87.3	113.5	121.2	135.8	151.3
QPT-5	0	12.6	22.3	36.9	46.6	66.9	74.7	96.0	102.8	115.4	129.0
QPT-6	0	8.7	13.6	21.3	27.1	37.8	42.7	54.3	58.2	64.9	72.7
MS-1	0	15.5	27.1	45.6	59.1	85.3	96.0	124.1	132.8	149.3	166.8
MS-2	0	19.4	32.0	52.4	66.0	94.1	105.8	134.9	144.6	163.0	182.4
MS-3	0	N/A	N/A	N/A	N/A	N/A	N/A	N/A	N/A	N/A	N/A
MS-4	0	15.5	27.2	46.6	61.2	91.3	102.9	135.0	144.7	163.2	182.6
MS-5	0	17.5	30.1	50.5	66.0	98.0	110.6	144.6	155.3	175.7	198.0
MS-6	0	11.6	20.4	35.9	47.5	72.8	83.4	111.6	121.3	137.8	156.2
QPB-1	0	7.8	12.6	20.4	25.2	35.9	39.8	51.5	54.4	62.2	69.0
QPB-2	0	1.0	9.9	18.8	10.9	14.8	18.8	28.7	33.6	40.5	33.6
QPB-3	0	13.6	22.3	36.9	47.5	69.9	78.6	101.9	108.7	124.2	137.8
QPB-4	0	12.6	22.3	36.9	47.5	68.9	78.6	100.9	108.7	122.2	136.8
QPB-5	0	12.6	21.4	34.0	43.7	62.1	69.9	89.3	95.2	106.8	118.5
QPB-6	0	7.9	13.8	20.7	26.6	40.4	47.3	60.1	64.0	72.9	79.8
Displacement											
TQP-0	0.0000	0.0043	0.0065	0.0129	0.0151	0.0194	0.0280	0.0345	0.0345	0.0409	0.0474
tqp-1	0.0000	0.0000	0.0065	0.0065	0.0130	0.0217	0.0261	0.0347	0.0347	0.0434	0.0478
tqp-2	0.0000	0.0022	0.0055	0.0099	0.0144	0.0243	0.0276	0.0365	0.0398	0.0431	0.0497
tqp-3	0.0000	0.0022	0.0022	0.0065	0.0043	0.0172	0.0194	0.0258	0.0323	0.0387	0.0387
tqp-4	0.0000	0.0000	0.0043	0.0118	0.0151	0.0258	0.0280	0.0345	0.0377	0.0431	0.0474
TQP-5	0.0000	0.0000	0.0000	0.0046	0.0138	0.0183	0.0229	0.0321	0.0321	0.0367	0.0459
Mid-span-0	0.0021	0.0000	0.0021	0.0086	0.0129	0.0258	0.0258	0.0408	0.0408	0.0472	0.0536
mid-span-1	0.0022	0.0045	0.0067	0.0134	0.0201	0.0268	0.0357	0.0468	0.0468	0.0557	0.0624
mid-span-2	0.0000	0.0000	0.0000	0.0000	0.0000	0.0000	0.0011	0.0000	0.0000	0.0011	0.0000
mid-span-4	0.0000	0.0044	0.0089	0.0167	0.0211	0.0322	0.0356	0.0478	0.0512	0.0567	0.0634
mid-span-5	0.0022	0.0065	0.0043	0.0130	0.0195	0.0325	0.0325	0.0455	0.0455	0.0541	0.0606
bqp-1	0.0000	0.0000	0.0000	0.0011	0.0011	0.0011	0.0011	0.0011	0.0011	0.0000	0.0000
BQP-2	N/A	N/A	N/A	N/A	N/A	N/A	N/A	N/A	N/A	N/A	N/A
BQP-3	0.0046	0.0092	0.0092	0.0183	0.0229	0.0321	0.0321	0.0413	0.0459	0.0505	0.0596
BQP-4	0.0000	0.0000	0.0000	0.0091	0.0091	0.0228	0.0228	0.0319	0.0364	0.0410	0.0455
BQP-5	0.0000	0.0065	0.0065	0.0130	0.0173	0.0259	0.0324	0.0389	0.0389	0.0454	0.0540

Slab: XOREX-25

Test: Longitudinal Linear Load along Left Third Point (Figure 5.3-G)

Strain Gage Readings are in $\mu\text{in}/\text{in}$.

Displacement Readings are in inches.

Strain Gage	Load in lbs.															
	0	1256.1	2430.2	3711	4515.5	5114.9	6280.7	6962.2	8341.5	8998.3	10426	11157	12331	13136	13965	14827
QPT-1	0	11.6	19.4	30.1	40.7	46.5	58.2	65.0	79.5	85.3	98.9	105.7	126.0	128.0	209.4	300.6
QPT-2	0	14.5	28.1	44.6	62.1	71.8	90.2	100.9	123.2	132.9	156.1	167.8	187.2	208.5	232.8	249.3
QPT-3	0	11.6	23.3	35.9	51.4	59.2	74.7	84.4	102.8	111.6	131.9	142.6	164.9	182.4	208.6	240.6
QPT-4	0	10.7	20.4	31.0	44.6	51.4	65.9	74.7	92.1	100.9	120.3	130.0	151.3	166.8	190.1	213.4
QPT-5	0	8.7	16.5	26.2	36.9	42.7	54.3	62.1	76.6	82.4	98.9	107.7	125.1	137.7	155.2	171.7
QPT-6	0	4.8	9.7	14.5	20.4	23.3	29.1	33.0	40.7	43.6	52.3	56.2	64.9	71.7	79.5	87.2
MS-1	0	14.5	28.1	41.7	58.2	66.9	83.4	93.1	120.2	131.9	246.3	271.5	289.0	305.4	338.4	381.1
MS-2	0	12.6	24.3	35.9	49.5	57.2	70.8	78.6	95.1	101.9	118.4	130.0	212.5	246.5	262.0	287.2
MS-3	0	-3.5	-6.2	-9.1	-12.4	-14.2	-17.4	-19.5	-23.6	-25.7	-31.0	-33.3	-38.3	-47.2	-63.4	-86.7
MS-4	0	10.7	18.4	26.2	35.0	39.8	48.5	54.4	65.1	70.9	84.5	91.3	106.8	117.5	128.2	135.9
MS-5	0	10.7	19.4	29.1	39.8	45.6	56.3	62.1	75.7	81.5	98.0	106.7	124.2	136.8	154.3	173.7
MS-6	0	5.8	11.6	17.5	24.2	28.1	34.9	38.8	47.5	51.4	61.1	66.0	75.7	83.4	92.2	100.9
QPB-1	0	10.7	21.4	32.0	44.7	50.5	64.1	71.9	87.4	95.2	109.7	114.6	111.7	117.5	125.3	131.1
QPB-2	0	N/A	N/A	N/A	N/A	N/A	N/A	N/A	N/A	N/A	N/A	N/A	N/A	N/A	N/A	N/A
QPB-3	0	13.6	26.2	39.8	55.3	63.1	78.6	88.3	106.7	116.4	137.8	148.4	167.8	181.4	196.0	215.4
QPB-4	0	10.7	21.3	33.0	45.6	53.4	66.9	75.7	92.2	100.9	121.3	131.9	151.3	165.9	182.4	199.9
QPB-5	0	8.7	17.5	27.2	37.9	43.7	55.3	62.1	75.7	82.5	100.0	108.7	126.2	137.9	150.5	163.1
QPB-6	0	5.9	10.9	14.8	20.7	24.7	30.6	34.6	42.5	46.4	55.3	60.2	69.1	75.1	82.0	89.9
Displacement																
TQP-0	0.0000	0.0065	0.0194	0.0280	0.0323	0.0388	0.0474	0.0453	0.0603	0.0603	0.0733	0.0776	0.0862	0.0927	0.0991	0.1121
tqp-1	0.0022	0.0022	0.0043	0.0130	0.0217	0.0261	0.0326	0.0347	0.0456	0.0478	0.0565	0.0630	0.0695	0.0760	0.0890	0.0977
tqp-2	0.0011	0.0033	0.0088	0.0133	0.0177	0.0210	0.0287	0.0321	0.0387	0.0409	0.0497	0.0520	0.0619	0.0663	0.0741	0.0840
tqp-3	0.0000	0.0000	0.0000	0.0000	0.0000	0.0000	0.0065	0.0086	0.0129	0.0194	0.0194	0.0258	0.0323	0.0323	0.0387	0.0452
tqp-4	0.0000	0.0000	0.0011	0.0000	0.0011	0.0011	0.0032	0.0043	0.0065	0.0086	0.0140	0.0161	0.0205	0.0248	0.0280	0.0301
TQP-5	0.0000	0.0000	0.0000	0.0000	0.0000	0.0000	0.0000	0.0000	0.0046	0.0046	0.0046	0.0046	0.0138	0.0138	0.0138	0.0183
Mid-span-0	0.0021	0.0000	0.0129	0.0236	0.0343	0.0322	0.0472	0.0536	0.0601	0.0687	0.0794	0.0858	0.1009	0.1073	0.1223	0.1352
mid-span-1	0.0022	0.0045	0.0111	0.0268	0.0334	0.0334	0.0468	0.0491	0.0602	0.0691	0.0803	0.0803	0.0959	0.1093	0.1249	0.1360
mid-span-2	0.0000	0.0011	0.0000	0.0000	0.0000	0.0000	0.0011	0.0000	0.0000	0.0000	0.0011	0.0000	0.0000	0.0000	0.0011	0.0000
mid-span-4	0.0000	0.0000	0.0022	0.0056	0.0078	0.0100	0.0133	0.0156	0.0200	0.0222	0.0278	0.0311	0.0356	0.0389	0.0434	0.0478
mid-span-5	0.0000	0.0000	0.0022	0.0000	0.0022	0.0065	0.0043	0.0065	0.0130	0.0130	0.0195	0.0195	0.0195	0.0260	0.0260	0.0325
bqp-1	0.0000	0.0000	0.0000	0.0000	0.0000	0.0000	0.0000	0.0000	0.0000	0.0000	0.0000	0.0000	0.0000	0.0000	0.0000	0.0000
BQP-2	0.0000	N/A	N/A	N/A	N/A	N/A	N/A	N/A	N/A	N/A	N/A	N/A	N/A	N/A	N/A	N/A
BQP-3	0.0000	0.0000	0.0000	0.0046	0.0046	0.0138	0.0138	0.0183	0.0183	0.0275	0.0321	0.0367	0.0413	0.0413	0.0459	0.0550
BQP-4	0.0000	0.0000	0.0000	0.0000	0.0000	0.0000	0.0000	0.0000	0.0046	0.0046	0.0046	0.0137	0.0137	0.0182	0.0182	0.0273
BQP-5	0.0022	0.0022	0.0022	0.0022	0.0022	0.0000	0.0000	0.0065	0.0043	0.0043	0.0108	0.0108	0.0108	0.0130	0.0195	0.0195

Slab: XOREX-25

Test: Longitudinal linear Load along Right Third Point (Figure 5.3-H)

Strain Gage Readings are in $\mu\text{in/in}$.

Displacement Readings are in inches.

Strain Gage	Load in lbs.												
	1239.7	2110	3185.5	4326.7	4975.3	6338.2	7060.7	8136.2	9022.9	9909.6	11108	11954	12914
QPT-1	5.8	10.7	18.4	26.2	31.0	43.6	50.4	61.1	71.7	82.4	98.9	111.5	127.0
QPT-2	8.7	16.5	27.2	39.8	46.5	64.0	73.7	87.3	99.9	113.5	133.8	148.4	167.8
QPT-3	10.7	19.4	32.0	45.6	53.4	70.8	80.5	95.1	107.7	121.3	139.7	154.3	172.7
QPT-4	12.6	22.3	35.9	51.4	61.1	80.5	91.2	106.7	119.3	132.9	151.3	164.9	181.4
QPT-5	13.6	25.2	39.8	55.3	64.0	83.4	94.1	108.6	121.2	131.9	147.4	158.1	170.7
QPT-6	10.7	19.4	29.1	40.7	47.5	61.1	68.8	80.5	89.2	97.9	108.6	116.3	123.1
MS-1	7.8	15.5	26.2	37.8	45.6	61.1	69.8	83.4	96.0	109.6	129.0	143.5	163.9
MS-2	11.6	22.3	35.9	50.4	59.2	76.6	87.3	101.9	117.4	133.9	159.1	178.5	206.7
MS-3	N/A	N/A	N/A	N/A	N/A	N/A	N/A	N/A	N/A	N/A	N/A	N/A	N/A
MS-4	12.6	21.4	33.0	44.7	51.5	66.0	74.8	88.4	102.9	115.5	297.2	337.0	373.0
MS-5	18.4	33.0	53.4	74.7	87.3	114.5	130.0	155.3	185.3	253.3	334.8	379.5	416.4
MS-6	14.6	25.2	39.8	54.3	63.1	81.5	91.2	110.6	124.2	143.6	265.9	303.7	372.6
QPB-1	4.9	7.8	12.6	17.5	21.4	27.2	30.1	35.0	39.8	45.6	53.4	60.2	68.0
QPB-2	N/A	N/A	N/A	N/A	N/A	N/A	N/A	N/A	N/A	N/A	N/A	N/A	N/A
QPB-3	10.7	20.4	32.0	44.6	52.4	68.9	75.7	90.2	102.8	115.5	133.9	147.5	166.9
QPB-4	11.6	21.3	34.9	49.5	57.2	75.7	84.4	98.9	112.5	126.1	143.6	157.2	175.6
QPB-5	12.6	22.3	35.9	50.5	59.2	76.7	84.5	98.1	107.8	116.5	127.2	134.0	141.8
QPB-6	1.0	4.9	14.8	26.6	34.5	49.3	53.2	64.0	70.0	77.8	92.6	108.4	125.1
Displacement													
TQP-0	0.0000	0.0000	0.0000	0.0022	0.0022	0.0086	0.0108	0.0108	0.0151	0.0172	0.0172	0.0237	0.0237
tqp-1	0.0022	0.0022	0.0022	0.0022	0.0087	0.0087	0.0152	0.0174	0.0195	0.0239	0.0304	0.0304	0.0391
tqp-2	0.0011	0.0044	0.0077	0.0122	0.0144	0.0221	0.0254	0.0298	0.0343	0.0376	0.0453	0.0486	0.0564
tqp-3	0.0022	0.0022	0.0043	0.0065	0.0108	0.0172	0.0237	0.0301	0.0366	0.0387	0.0495	0.0559	0.0624
tqp-4	0.0011	0.0097	0.0172	0.0258	0.0291	0.0377	0.0431	0.0484	0.0560	0.0614	0.0700	0.0775	0.0851
TQP-5	0.0046	0.0092	0.0229	0.0275	0.0321	0.0413	0.0459	0.0550	0.0596	0.0688	0.0826	0.0872	0.1009
Mid-span-0	0.0021	0.0021	0.0021	0.0043	0.0043	0.0043	0.0021	0.0021	0.0107	0.0107	0.0172	0.0215	0.0236
mid-span-1	0.0089	0.0089	0.0089	0.0156	0.0156	0.0223	0.0245	0.0290	0.0357	0.0357	0.0446	0.0491	0.0580
mid-span-2	0.0011	0.0011	0.0011	0.0022	0.0022	0.0022	0.0022	0.0033	0.0022	0.0022	0.0022	0.0022	0.0022
mid-span-4	0.0100	0.0178	0.0278	0.0378	0.0434	0.0545	0.0601	0.0689	0.0767	0.0867	0.1001	0.1101	0.1257
mid-span-5	0.0043	0.0173	0.0260	0.0390	0.0455	0.0584	0.0649	0.0714	0.0844	0.0931	0.1061	0.1212	0.1342
bqp-1	0.0000	0.0000	0.0000	0.0000	0.0000	0.0000	0.0000	0.0000	0.0000	0.0000	0.0011	0.0000	0.0000
BQP-2	N/A	N/A	N/A	N/A	N/A	N/A	N/A	N/A	N/A	N/A	N/A	N/A	N/A
BQP-3	0.0000	0.0092	0.0183	0.0229	0.0229	0.0367	0.0367	0.0459	0.0505	0.0596	0.0642	0.0734	0.0780
BQP-4	0.0000	0.0091	0.0228	0.0273	0.0364	0.0410	0.0501	0.0546	0.0637	0.0683	0.0774	0.0819	0.0956
BQP-5	0.0086	0.0151	0.0303	0.0367	0.0432	0.0497	0.0562	0.0627	0.0692	0.0778	0.0908	0.0973	0.1037

Slab: XOREX-25

Test: Transverse Linear Load Along Mid-Span (Figure 5.3-I)

Strain Gage Readings are in $\mu\text{in/in}$.

Displacement readings are in inches.

Strain Gage	Load in lbs.															
	0	1305.4	2118.2	3087	4318.5	5714.2	6617.4	7044.3	7931	9269.2	10755	11387	12044	13201	13779	10114
QPT-1	0	10.7	20.4	33.0	50.4	71.7	85.3	92.1	105.7	125.1	148.4	160.0	174.5	195.9	206.5	109.6
QPT-2	0	12.6	23.3	36.8	56.2	79.5	94.1	101.8	115.4	136.7	158.1	166.8	171.7	213.4	242.5	116.4
QPT-3	0	12.6	22.3	35.9	54.3	76.6	90.2	98.0	111.6	132.0	152.3	164.9	178.5	229.0	249.4	154.3
QPT-4	0	12.6	22.3	35.9	54.3	75.6	89.2	96.0	109.6	129.0	149.4	157.1	165.9	202.7	235.7	152.3
QPT-5	0	13.6	23.3	34.9	51.4	70.8	82.4	89.2	100.9	119.3	138.7	146.5	155.2	167.8	178.5	150.3
QPT-6	0	8.7	14.5	22.3	32.0	42.7	49.4	53.3	60.1	70.8	83.4	89.2	96.0	108.6	112.4	128.0
MS-1	0	17.5	32.0	50.4	74.7	103.7	120.2	129.0	146.4	172.6	206.5	225.9	257.0	370.5	462.7	448.1
MS-2	0	23.3	41.7	64.0	92.2	124.2	145.5	155.3	175.6	207.7	258.1	293.1	338.7	365.9	461.1	732.1
MS-3	N/A	N/A	N/A	N/A	N/A	N/A	N/A	N/A	N/A	N/A	N/A	N/A	N/A	N/A	N/A	N/A
MS-4	0	23.3	44.7	71.9	107.8	147.6	172.9	185.5	211.7	252.5	298.2	308.9	341.0	398.3	460.5	646.2
MS-5	0	20.4	36.9	60.2	91.2	127.1	149.5	161.1	184.4	220.3	264.0	292.2	338.8	407.7	498.0	672.9
MS-6	0	13.6	25.2	42.7	66.0	93.1	110.6	119.3	136.8	164.0	197.0	213.5	238.7	299.9	380.4	499.9
QPB-1	0	6.8	12.6	19.4	28.2	37.9	44.7	47.6	54.4	64.1	75.7	80.6	87.4	97.1	101.0	74.8
QPB-2	0	0.0	3.0	13.8	21.7	32.6	32.6	32.6	36.6	48.4	53.4	56.3	68.2	77.1	112.6	56.3
QPB-3	0	11.6	20.4	33.0	49.5	69.9	82.5	88.3	100.9	119.3	138.7	145.5	161.1	172.7	204.7	165.0
QPB-4	0	11.6	20.4	33.0	49.5	68.9	81.5	87.3	99.9	118.4	137.8	144.5	149.4	158.1	184.3	155.2
QPB-5	0	11.7	20.4	31.1	45.6	62.1	72.8	77.7	88.4	103.9	121.4	128.2	135.9	158.3	186.4	170.9
QPB-6	0	8.9	13.8	21.7	31.5	44.3	51.2	54.2	63.1	74.9	88.7	95.6	102.5	118.2	122.2	96.6
Displacements																
TQP-0	0.0022	0.0065	0.0065	0.0129	0.0194	0.0259	0.0323	0.0323	0.0388	0.0453	0.0517	0.0582	0.0582	0.0711	0.0776	0.1466
tqp-1	0.0000	0.0000	0.0065	0.0065	0.0152	0.0261	0.0282	0.0347	0.0369	0.0434	0.0565	0.0586	0.0651	0.0717	0.0847	0.1346
tqp-2	0.0000	0.0033	0.0055	0.0099	0.0188	0.0276	0.0321	0.0332	0.0398	0.0453	0.0553	0.0575	0.0630	0.0741	0.0829	0.1371
tqp-3	0.0000	0.0000	0.0000	0.0065	0.0129	0.0194	0.0258	0.0258	0.0344	0.0409	0.0473	0.0538	0.0602	0.0667	0.0796	0.1269
tqp-4	0.0000	0.0000	0.0054	0.0118	0.0205	0.0280	0.0323	0.0345	0.0398	0.0463	0.0549	0.0592	0.0635	0.0732	0.0818	0.1303
TQP-5	0.0000	0.0000	0.0000	0.0046	0.0138	0.0275	0.0275	0.0321	0.0413	0.0459	0.0505	0.0596	0.0596	0.0734	0.0780	0.1239
Mid-span-0	0.0021	0.0021	0.0064	0.0129	0.0193	0.0279	0.0322	0.0408	0.0451	0.0536	0.0665	0.0687	0.0730	0.0944	0.1073	0.2146
mid-span-1	0.0022	0.0045	0.0067	0.0111	0.0268	0.0312	0.0379	0.0468	0.0513	0.0602	0.0736	0.0736	0.0892	0.1026	0.1226	0.2319
mid-span-2	0.0000	0.0011	0.0011	0.0011	0.0000	0.0000	0.0011	0.0000	0.0000	0.0000	0.0000	0.0000	0.0000	0.0000	0.0011	0.0000
mid-span-4	0.0000	0.0056	0.0111	0.0189	0.0278	0.0389	0.0456	0.0478	0.0545	0.0645	0.0756	0.0812	0.0879	0.1034	0.1212	0.2269
mid-span-5	0.0022	0.0043	0.0043	0.0152	0.0260	0.0325	0.0411	0.0476	0.0541	0.0606	0.0736	0.0801	0.0866	0.0996	0.1125	0.2099
bqp-1	0.0011	0.0011	0.0011	0.0000	0.0011	0.0011	0.0011	0.0011	0.0011	0.0011	0.0011	0.0011	0.0011	0.0011	0.0011	0.0011
BQP-2	N/A	N/A	N/A	N/A	N/A	N/A	N/A	N/A	N/A	N/A	N/A	N/A	N/A	N/A	N/A	N/A
BQP-3	0.0000	0.0046	0.0046	0.0138	0.0229	0.0229	0.0321	0.0367	0.0367	0.0459	0.0596	0.0596	0.0642	0.0780	0.0872	0.1376
BQP-4	0.0046	0.0000	0.0046	0.0046	0.0091	0.0182	0.0228	0.0228	0.0319	0.0364	0.0501	0.0501	0.0546	0.0683	0.0774	0.1184
BQP-5	0.0000	0.0065	0.0108	0.0151	0.0195	0.0346	0.0411	0.0411	0.0475	0.0540	0.0605	0.0670	0.0670	0.0800	0.0886	0.1297

Slab: XOERX-25

Test: Transverse Linear Load Along Top Quarter Point (Figure 5.3-J)

Strain Gage Readings are in $\mu\text{in}/\text{in}$.

Displacement Readings are in inches.

Strain Gage	Load in lbs.															
	0	1379.3	2159.2	3349.7	4105	5492.6	6272.5	7274.2	8078.8	9507.3	10057	10706	12052	12848	13965	15188
QPT-1	0	8.7	14.5	23.3	29.1	39.7	45.6	53.3	59.1	70.8	74.7	80.5	91.1	97.9	103.7	117.3
QPT-2	0	18.4	31.0	51.4	64.0	88.2	101.8	120.2	134.8	160.0	170.7	183.3	208.5	228.9	261.9	307.5
QPT-3	0	20.4	34.0	56.3	70.8	97.0	112.5	132.9	148.4	176.6	187.3	200.8	228.0	239.7	264.9	294.0
QPT-4	0	21.3	36.9	61.1	77.6	107.6	125.1	148.4	165.8	198.8	212.4	225.0	249.3	260.9	290.0	316.2
QPT-5	0	17.5	29.1	47.5	59.2	81.5	94.1	110.6	123.2	146.4	157.1	167.8	192.0	209.5	236.7	269.7
QPT-6	0	8.7	14.5	23.3	29.1	39.7	46.5	54.3	60.1	71.7	76.6	81.4	93.1	100.8	115.4	128.9
MS-1	0	7.8	12.6	19.4	24.2	33.0	38.8	44.6	50.4	60.1	64.0	67.9	77.6	83.4	91.1	99.9
MS-2	0	6.8	11.6	17.5	22.3	30.1	34.9	40.7	44.6	53.4	57.2	60.1	67.9	72.8	79.6	86.3
MS-3	N/A	N/A	N/A	N/A	N/A	N/A	N/A	N/A	N/A	N/A	N/A	N/A	N/A	N/A	N/A	N/A
MS-4	0	5.8	9.7	14.6	17.5	23.3	26.2	30.1	33.0	37.9	40.8	43.7	48.5	51.5	55.3	59.2
MS-5	0	7.8	12.6	20.4	26.2	34.9	40.7	47.5	52.4	62.1	66.9	70.8	80.5	86.4	94.1	101.9
MS-6	0	6.8	11.6	18.4	22.3	30.1	34.9	40.7	45.6	54.3	57.2	61.1	69.8	74.7	82.5	90.2
QPB-1	0	3.9	6.8	9.7	12.6	17.5	19.4	23.3	26.2	31.1	33.0	35.9	40.8	44.7	48.6	53.4
QPB-2	N/A	N/A	N/A	N/A	N/A	N/A	N/A	N/A	N/A	N/A	N/A	N/A	N/A	N/A	N/A	N/A
QPB-3	0	5.8	8.7	12.6	15.5	21.3	25.2	29.1	33.0	39.8	42.7	45.6	52.4	56.3	62.1	67.9
QPB-4	0	4.8	7.8	11.6	14.5	20.4	23.3	28.1	31.0	37.8	40.7	44.6	50.4	54.3	60.1	66.0
QPB-5	0	4.9	7.8	11.7	15.5	21.4	24.3	29.1	33.0	39.8	42.7	45.6	52.4	57.3	62.1	68.0
QPB-6	0	4.0	8.9	12.8	14.8	19.8	21.7	25.7	29.6	33.6	36.5	39.5	44.4	47.4	52.3	57.3
Displacement																
TQP-0	0.0000	0.0000	0.0000	0.0065	0.0065	0.0151	0.0194	0.0216	0.0216	0.0280	0.0280	0.0345	0.0409	0.0409	0.0409	0.0474
tqp-1	0.0022	0.0022	0.0022	0.0043	0.0043	0.0130	0.0130	0.0195	0.0195	0.0282	0.0282	0.0347	0.0347	0.0413	0.0434	0.0478
tqp-2	0.0000	0.0033	0.0066	0.0133	0.0155	0.0210	0.0243	0.0298	0.0332	0.0398	0.0420	0.0453	0.0520	0.0553	0.0586	0.0674
tqp-3	0.0000	0.0000	0.0000	0.0000	0.0000	0.0065	0.0129	0.0194	0.0194	0.0258	0.0323	0.0323	0.0387	0.0452	0.0452	0.0602
tqp-4	0.0000	0.0000	0.0032	0.0054	0.0086	0.0161	0.0194	0.0237	0.0280	0.0334	0.0355	0.0377	0.0431	0.0463	0.0506	0.0560
TQP-5	0.0000	0.0000	0.0000	0.0046	0.0046	0.0138	0.0183	0.0183	0.0229	0.0321	0.0321	0.0321	0.0367	0.0459	0.0459	0.0505
Mid-span-0	0.0000	0.0000	0.0000	0.0064	0.0064	0.0129	0.0129	0.0193	0.0193	0.0258	0.0279	0.0322	0.0386	0.0386	0.0472	0.0472
mid-span-1	0.0022	0.0000	0.0022	0.0067	0.0134	0.0134	0.0201	0.0201	0.0268	0.0334	0.0334	0.0379	0.0424	0.0468	0.0468	0.0557
mid-span-2	0.0011	0.0011	0.0000	0.0011	0.0011	0.0011	0.0011	0.0011	0.0011	0.0011	0.0022	0.0011	0.0011	0.0011	0.0011	0.0011
mid-span-4	0.0000	0.0022	0.0056	0.0111	0.0133	0.0189	0.0234	0.0278	0.0311	0.0367	0.0389	0.0423	0.0478	0.0512	0.0556	0.0623
mid-span-5	0.0022	0.0022	0.0065	0.0108	0.0130	0.0195	0.0173	0.0260	0.0281	0.0325	0.0390	0.0390	0.0455	0.0519	0.0541	0.0584
bqp-1	0.0000	0.0000	0.0000	0.0000	0.0000	0.0000	0.0000	0.0000	0.0000	0.0000	0.0000	0.0000	0.0000	0.0000	0.0000	0.0000
BQP-2	N/A	N/A	N/A	N/A	N/A	N/A	N/A	N/A	N/A	N/A	N/A	N/A	N/A	N/A	N/A	N/A
BQP-3	0.0046	0.0046	0.0046	0.0046	0.0092	0.0092	0.0138	0.0183	0.0183	0.0229	0.0229	0.0321	0.0321	0.0367	0.0367	0.0413
BQP-4	0.0000	0.0000	0.0000	0.0000	0.0000	0.0000	0.0046	0.0046	0.0137	0.0137	0.0182	0.0182	0.0228	0.0273	0.0273	0.0319
BQP-5	0.0000	0.0000	0.0065	0.0065	0.0086	0.0130	0.0151	0.0216	0.0195	0.0281	0.0281	0.0259	0.0346	0.0346	0.0411	0.0432

Slab: XOREX-25

Test: Transverse Linear Load Along Bottom Quarter Point (Figure 5.3-K)

Strain Gage Readings are in $\mu\text{in/in}$.

Displacement Readings are in inches.

Strain Gage	Load in lbs.															
	0	1001.6	2274.2	3119.8	4220	4934.3	6231.5	7052.5	7906.4	8924.4	10090	10952	12077	13472	13924	14811
QPT-1	0	2.9	6.8	9.7	13.6	16.5	20.4	23.3	26.2	30.1	34.9	37.8	42.7	47.5	49.4	53.3
QPT-2	0	3.9	8.7	12.6	17.5	21.3	27.1	31.0	35.9	41.7	47.5	52.4	58.2	65.9	67.9	72.7
QPT-3	0	2.9	7.8	11.6	16.5	19.4	26.2	30.1	34.0	39.8	46.6	50.4	57.2	65.0	67.9	72.8
QPT-4	0	2.9	8.7	12.6	16.5	20.4	27.2	31.0	35.9	40.7	47.5	52.4	59.2	67.9	70.8	75.6
QPT-5	0	2.9	8.7	12.6	17.5	20.4	27.2	31.0	35.9	41.7	47.5	52.4	58.2	65.9	67.9	72.7
QPT-6	0	2.9	6.8	9.7	13.6	16.5	21.3	24.2	27.1	31.0	35.9	38.8	43.6	48.5	50.4	54.3
MS-1	0	5.8	12.6	18.4	25.2	30.1	38.8	44.6	50.4	57.2	65.0	71.7	79.5	90.2	94.0	101.8
MS-2	0	4.9	12.6	18.4	24.3	28.1	36.9	41.7	46.6	53.4	61.1	66.0	73.7	82.5	85.4	91.2
MS-3	N/A	N/A	N/A	N/A	N/A	N/A	N/A	N/A	N/A	N/A	N/A	N/A	N/A	N/A	N/A	N/A
MS-4	0	3.9	10.7	14.6	19.4	23.3	29.1	33.0	35.9	40.8	46.6	50.5	55.3	62.1	64.1	68.0
MS-5	0	5.8	14.6	19.4	27.2	32.0	40.7	46.6	52.4	60.2	68.9	74.7	82.5	92.2	95.1	101.9
MS-6	0	4.8	11.6	16.5	23.3	27.2	34.9	39.8	44.6	50.4	58.2	63.1	70.8	79.5	81.5	88.3
QPB-1	0	5.8	14.6	20.4	29.1	35.0	44.7	51.5	58.3	67.0	75.7	83.5	93.2	108.8	114.6	136.0
QPB-2	N/A	N/A	N/A	N/A	N/A	N/A	N/A	N/A	N/A	N/A	N/A	N/A	N/A	N/A	N/A	N/A
QPB-3	0	13.6	34.0	49.5	69.8	82.5	106.7	121.3	136.8	156.2	177.5	193.1	215.4	249.3	263.9	299.8
QPB-4	0	12.6	34.9	50.4	72.8	87.3	113.5	130.0	147.5	168.8	192.1	210.5	235.8	275.5	293.0	318.2
QPB-5	0	10.7	28.2	41.7	58.3	69.9	90.3	102.9	116.5	133.0	152.4	166.0	185.5	216.5	233.0	258.3
QPB-6	0	5.9	13.8	19.7	27.6	33.6	43.4	50.4	57.3	65.2	73.1	81.0	89.9	106.7	116.5	141.2
Displacement																
TQP-0	0.0000	0.0000	0.0022	0.0000	0.0065	0.0065	0.0129	0.0129	0.0129	0.0194	0.0194	0.0194	0.0259	0.0323	0.0323	0.0323
tqp-1	0.0022	0.0022	0.0022	0.0022	0.0000	0.0022	0.0065	0.0065	0.0130	0.0130	0.0130	0.0195	0.0195	0.0261	0.0261	0.0326
tqp-2	0.0000	0.0000	0.0033	0.0055	0.0099	0.0122	0.0155	0.0166	0.0199	0.0221	0.0243	0.0265	0.0309	0.0365	0.0387	0.0420
tqp-3	0.0022	0.0022	0.0000	0.0022	0.0000	0.0022	0.0022	0.0086	0.0086	0.0086	0.0151	0.0151	0.0215	0.0237	0.0280	0.0280
tqp-4	0.0011	0.0011	0.0011	0.0043	0.0054	0.0065	0.0108	0.0140	0.0172	0.0194	0.0226	0.0269	0.0312	0.0345	0.0355	0.0388
TQP-5	0.0000	0.0000	0.0000	0.0000	0.0046	0.0046	0.0138	0.0138	0.0138	0.0183	0.0183	0.0229	0.0229	0.0321	0.0321	0.0367
Mid-span-0	0.0000	0.0000	0.0000	0.0000	0.0064	0.0086	0.0129	0.0193	0.0193	0.0258	0.0300	0.0343	0.0408	0.0472	0.0472	0.0536
mid-span-1	0.0000	0.0067	0.0045	0.0111	0.0111	0.0201	0.0268	0.0268	0.0334	0.0334	0.0401	0.0401	0.0468	0.0557	0.0557	0.0602
mid-span-2	0.0011	0.0000	0.0000	0.0011	0.0000	0.0011	0.0011	0.0000	0.0000	0.0000	0.0000	0.0011	0.0011	0.0000	0.0011	0.0011
mid-span-4	0.0011	0.0011	0.0067	0.0100	0.0156	0.0189	0.0245	0.0278	0.0311	0.0356	0.0400	0.0434	0.0478	0.0556	0.0578	0.0623
mid-span-5	0.0022	0.0022	0.0043	0.0043	0.0108	0.0195	0.0195	0.0260	0.0303	0.0325	0.0390	0.0390	0.0455	0.0541	0.0519	0.0584
bqp-1	0.0000	0.0000	0.0000	0.0000	0.0000	0.0000	0.0000	0.0000	0.0000	0.0000	0.0000	0.0000	0.0000	0.0000	0.0000	0.0000
BQP-2	N/A	N/A	N/A	N/A	N/A	N/A	N/A	N/A	N/A	N/A	N/A	N/A	N/A	N/A	N/A	N/A
BQP-3	0.0000	0.0000	0.0000	0.0046	0.0138	0.0138	0.0183	0.0275	0.0275	0.0321	0.0367	0.0367	0.0459	0.0505	0.0505	0.0596
BQP-4	0.0000	0.0000	0.0000	0.0046	0.0091	0.0091	0.0182	0.0228	0.0228	0.0319	0.0364	0.0364	0.0455	0.0501	0.0501	0.0592
BQP-5	0.0000	0.0000	0.0086	0.0151	0.0151	0.0216	0.0281	0.0281	0.0346	0.0346	0.0411	0.0432	0.0475	0.0562	0.0540	0.0627

Test Designation: XOREX50- Concentrated Loads
Cast Date: 07/16/2001
Test Date: 08/24/2001

Materials and Dimensions

General:

Width: 9 ft (3 panels)
Span length: 10 ft.
Type of Reinforcement: 50 lb/yd³ -1 ½” Xorex Fiber

Deck:

Deck type: 2VLI-20
Design Thickness: 0.0358 in
Height: 2 in
Area: 0.519 in²/ft
Yield Stress: 50 ksi
Ultimate Strength: 60 ksi

Concrete:

Test Strength: 4200 psi
Total Depth: 5.5 in

Results

Maximum Applied Load: 13.70 kips
Mid-Span Deflection at Maximum Load: 0.48 in
Quarter Point-1 Deflection at Maximum Load: 0.29 in
Quarter Point-2 Deflection at Maximum Load: 0.27 in
End Slip at Maximum Load: 0.00 in

Strains Due to Fresh Concrete (µε)

Strain Gage	1	2	3	4	5	6
Quarter Point-1	592.65	567.19	527.82	483.86	626.86	534.45
Mid-Span	857.73	862.03	826.51	748.37	N/A	817.92
Quarter Point-2	566.68	589.87	568.88	629.22	611.35	528.19

Table F-3 Non-Distributed Load Tests Data on XOREX-50 Slab
Slab: XOREX-50

Test: Concentrated Load at Bottom Quarter Point (Figure 5.3-A)

Strain Gage Readings are in $\mu\text{in/in}$.

Displacements Readings are in inches.

	Load in lbs.															
Strain Gage	0	541.87	1256.1	1592.7	2183.9	2528.7	3029.5	3620.6	4064	4548.4	5065.6	5574.7	5993.4	6527	7151	7791.4
QPT-1	0	3.9	8.7	10.7	14.6	17.5	21.4	25.2	28.1	32.0	35.9	39.8	42.7	47.6	52.4	58.2
QPT-2	0	6.8	15.5	19.4	26.2	31.1	36.9	44.6	50.5	56.3	63.1	69.9	75.7	83.5	92.2	100.9
QPT-3	0	6.8	15.5	19.4	27.2	32.0	37.9	45.6	52.4	58.3	65.1	71.9	77.7	86.4	95.2	104.9
QPT-4	0	4.9	10.7	13.6	19.4	23.3	27.2	33.0	37.9	42.7	47.6	53.4	57.3	63.1	69.9	77.7
QPT-5	0	1.9	3.9	4.8	6.8	7.8	9.7	11.6	12.6	14.5	16.5	17.5	19.4	22.3	24.2	26.2
QPT-6	0	1.9	3.9	4.9	6.8	7.8	8.7	10.7	11.6	13.6	14.6	16.5	17.5	19.4	21.4	23.3
MS-1	0	2.9	6.8	8.7	11.7	13.6	16.5	19.4	22.3	25.3	28.2	31.1	34.0	36.9	40.8	44.7
MS-2	0	2.9	5.8	7.8	10.7	12.6	15.5	18.5	21.4	23.3	26.2	29.2	31.1	34.0	37.9	41.8
MS-3	0	-0.9	-1.8	-2.4	-3.2	-3.8	-4.4	-5.3	-6.2	-6.8	-7.7	-8.6	-9.1	-10.0	-10.9	-11.8
MS-4	0	2.9	6.8	7.8	10.7	13.6	15.5	18.5	21.4	23.3	26.2	29.1	31.1	34.0	37.9	41.8
MS-5	N/A	N/A	N/A	N/A	N/A	N/A	N/A	N/A	N/A	N/A	N/A	N/A	N/A	N/A	N/A	N/A
MS-6	0	2.9	6.8	7.8	10.7	12.6	14.6	17.5	20.4	22.3	25.2	27.2	30.1	32.0	35.9	39.8
QPB-1	0	1.9	3.9	4.9	6.8	7.8	8.7	10.7	11.7	13.6	14.6	16.5	17.5	19.4	21.4	23.3
QPB-2	0	1.0	2.9	4.9	6.8	7.8	8.7	10.7	12.6	13.6	15.5	17.5	18.4	20.4	22.3	24.3
QPB-3	0	1.0	2.9	3.9	5.8	6.8	8.7	9.7	11.6	12.6	14.5	16.5	17.5	19.4	21.3	23.3
QPB-4	N/A	N/A	N/A	N/A	N/A	N/A	N/A	N/A	N/A	N/A	N/A	N/A	N/A	N/A	N/A	N/A
QPB-5	0.0	3.9	10.7	13.6	19.4	23.3	27.2	33.0	37.8	42.7	48.5	54.3	61.1	73.7	83.4	94.1
QPB-6	0.0	2.9	6.8	8.7	11.6	13.6	16.5	19.4	22.3	25.2	28.1	31.0	33.9	36.9	40.7	45.6
Displacement																
TQP-0	0.0000	0.0000	0.0043	0.0043	0.0065	0.0065	0.0065	0.0065	0.0065	0.0129	0.0151	0.0129	0.0129	0.0151	0.0216	0.0216
tqp-1	0.0000	0.0000	0.0000	0.0000	0.0000	0.0000	0.0000	0.0000	0.0000	0.0000	0.0065	0.0087	0.0087	0.0087	0.0087	0.0152
tqp-2	0.0000	0.0000	0.0022	0.0022	0.0033	0.0055	0.0066	0.0077	0.0099	0.0099	0.0122	0.0133	0.0144	0.0166	0.0177	0.0188
tqp-3	0.0022	0.0022	0.0022	0.0022	0.0022	0.0022	0.0022	0.0000	0.0022	0.0000	0.0022	0.0022	0.0022	0.0022	0.0086	0.0086
tqp-4	0.0000	0.0000	0.0000	0.0000	0.0000	0.0000	0.0022	0.0022	0.0043	0.0054	0.0075	0.0097	0.0118	0.0129	0.0151	0.0161
TQP-5	0.0000	0.0000	0.0000	0.0000	0.0000	0.0000	0.0000	0.0092	0.0092	0.0092	0.0092	0.0138	0.0138	0.0138	0.0138	0.0183
Mid-span-0	0.0000	0.0000	0.0000	0.0000	0.0021	0.0021	0.0021	0.0021	0.0021	0.0086	0.0086	0.0086	0.0086	0.0172	0.0150	0.0150
mid-span-1	0.0000	0.0000	0.0067	0.0067	0.0067	0.0067	0.0134	0.0156	0.0134	0.0156	0.0201	0.0223	0.0201	0.0268	0.0268	0.0268
mid-span-2	0.0000	0.0011	0.0022	0.0033	0.0055	0.0066	0.0100	0.0122	0.0144	0.0155	0.0177	0.0199	0.0210	0.0244	0.0266	0.0299
mid-span-4	0.0000	0.0011	0.0033	0.0044	0.0056	0.0078	0.0111	0.0133	0.0156	0.0167	0.0189	0.0211	0.0222	0.0245	0.0278	0.0311
mid-span-5	0.0043	0.0043	0.0043	0.0043	0.0043	0.0043	0.0043	0.0108	0.0108	0.0087	0.0108	0.0173	0.0173	0.0173	0.0238	0.0216
bqp-1	0.0022	0.0011	0.0011	0.0022	0.0044	0.0055	0.0077	0.0099	0.0111	0.0122	0.0144	0.0155	0.0177	0.0188	0.0221	0.0254
BQP-2	0.0000	0.0000	0.0000	0.0000	0.0091	0.0091	0.0091	0.0137	0.0137	0.0137	0.0228	0.0228	0.0228	0.0274	0.0274	0.0365
BQP-3	0.0000	0.0046	0.0000	0.0046	0.0092	0.0092	0.0092	0.0183	0.0183	0.0138	0.0229	0.0229	0.0229	0.0321	0.0321	0.0367
BQP-4	0.0000	0.0000	0.0000	0.0000	0.0000	0.0046	0.0046	0.0046	0.0137	0.0137	0.0137	0.0182	0.0182	0.0182	0.0273	0.0273
BQP-5	0.0000	0.0000	0.0065	0.0086	0.0065	0.0065	0.0151	0.0130	0.0130	0.0216	0.0216	0.0216	0.0216	0.0281	0.0281	0.0346

Concentrated Load at Bottom Quarter Point Continued.

Strain Gage	Load in lbs.														
	8193.7	8752	9088.6	9466.3	10073	10484	11100	11724	12093	12380	12922	13382	14187	14770	15197
QPT-1	61.2	66.0	68.0	71.8	76.7	80.6	87.4	94.2	99.0	102.9	109.7	116.5	125.2	132.0	139.8
QPT-2	107.7	115.5	120.3	126.2	134.9	139.7	148.5	156.2	159.2	160.1	170.8	185.4	203.8	220.3	236.8
QPT-3	111.7	119.4	124.3	131.1	144.7	153.4	170.9	168.0	170.0	192.3	212.7	228.2	242.8	274.9	294.3
QPT-4	82.5	88.3	92.2	97.1	107.8	114.6	127.2	145.6	157.3	169.9	190.3	211.7	216.5	238.8	251.5
QPT-5	28.1	30.1	32.0	33.0	34.9	35.9	37.8	40.7	41.7	42.7	45.6	47.5	50.4	52.4	53.3
QPT-6	24.3	26.2	27.2	28.1	30.1	31.1	33.0	34.9	36.9	37.9	38.8	40.8	43.7	45.6	46.6
MS-1	47.6	50.5	52.5	55.4	58.3	61.2	65.1	69.0	71.9	73.8	76.7	80.6	85.5	89.4	92.3
MS-2	44.7	48.6	50.5	53.5	58.3	60.3	64.1	67.1	69.0	70.0	72.9	73.9	76.8	78.7	79.7
MS-3	-12.7	-13.6	-13.9	-14.7	-15.3	-16.2	-16.8	-17.7	-18.3	-18.6	-19.2	-19.8	-20.6	-21.2	-21.8
MS-4	43.7	46.6	48.6	50.5	53.4	55.4	59.3	61.2	63.2	65.1	68.0	70.0	73.8	76.8	78.7
MS-5	N/A	N/A	N/A	N/A	N/A	N/A	N/A	N/A	N/A	N/A	N/A	N/A	N/A	N/A	N/A
MS-6	41.7	44.7	46.6	48.5	52.4	54.4	57.3	62.1	64.1	66.0	68.9	72.8	77.7	81.6	84.5
QPB-1	25.3	26.2	28.2	29.1	31.1	32.1	34.0	35.9	37.9	38.9	40.8	41.8	44.7	46.6	48.6
QPB-2	26.2	27.2	29.1	30.1	32.0	33.0	35.0	36.9	37.9	38.8	40.8	41.8	43.7	45.6	46.6
QPB-3	24.2	26.2	27.2	28.1	30.1	31.0	33.0	34.9	35.9	36.9	37.8	38.8	41.7	42.7	43.6
QPB-4	N/A	N/A	N/A	N/A	N/A	N/A	N/A	N/A	N/A	N/A	N/A	N/A	N/A	N/A	N/A
QPB-5	100.9	107.6	112.5	119.3	131.9	132.9	139.7	152.3	160.0	166.8	176.5	187.2	206.6	222.1	234.7
QPB-6	48.5	51.4	54.3	56.3	61.1	64.0	67.9	73.7	77.6	80.5	85.4	91.2	98.0	103.8	109.6
Displacement															
TQP-0	0.0216	0.0216	0.0280	0.0280	0.0280	0.0280	0.0280	0.0345	0.0366	0.0345	0.0345	0.0366	0.0409	0.0431	0.0431
tqp-1	0.0152	0.0152	0.0152	0.0152	0.0217	0.0239	0.0217	0.0217	0.0239	0.0304	0.0304	0.0304	0.0282	0.0369	0.0369
tqp-2	0.0199	0.0210	0.0221	0.0232	0.0254	0.0265	0.0287	0.0309	0.0321	0.0332	0.0354	0.0376	0.0398	0.0420	0.0431
tqp-3	0.0086	0.0065	0.0065	0.0151	0.0151	0.0151	0.0151	0.0215	0.0215	0.0194	0.0215	0.0258	0.0280	0.0280	0.0280
tqp-4	0.0172	0.0194	0.0194	0.0215	0.0226	0.0237	0.0248	0.0269	0.0280	0.0291	0.0301	0.0323	0.0355	0.0388	0.0409
TQP-5	0.0229	0.0229	0.0229	0.0275	0.0275	0.0275	0.0275	0.0321	0.0321	0.0367	0.0367	0.0413	0.0413	0.0413	0.0505
Mid-span-0	0.0236	0.0215	0.0215	0.0215	0.0279	0.0300	0.0300	0.0365	0.0365	0.0343	0.0386	0.0429	0.0429	0.0494	0.0494
mid-span-1	0.0334	0.0357	0.0357	0.0334	0.0424	0.0424	0.0424	0.0491	0.0491	0.0491	0.0557	0.0557	0.0624	0.0624	0.0624
mid-span-2	0.0321	0.0343	0.0365	0.0376	0.0399	0.0410	0.0443	0.0476	0.0509	0.0520	0.0543	0.0576	0.0598	0.0631	0.0653
mid-span-4	0.0322	0.0345	0.0356	0.0367	0.0400	0.0411	0.0434	0.0478	0.0512	0.0523	0.0534	0.0556	0.0601	0.0634	0.0656
mid-span-5	0.0238	0.0303	0.0303	0.0303	0.0368	0.0368	0.0368	0.0433	0.0433	0.0455	0.0433	0.0519	0.0519	0.0584	0.0584
bqp-1	0.0276	0.0298	0.0309	0.0321	0.0343	0.0365	0.0387	0.0420	0.0442	0.0453	0.0475	0.0497	0.0542	0.0564	0.0586
BQP-2	0.0319	0.0319	0.0411	0.0411	0.0411	0.0456	0.0456	0.0547	0.0547	0.0547	0.0593	0.0593	0.0684	0.0684	0.0730
BQP-3	0.0367	0.0367	0.0459	0.0459	0.0459	0.0459	0.0505	0.0505	0.0596	0.0596	0.0642	0.0642	0.0734	0.0734	0.0780
BQP-4	0.0228	0.0319	0.0319	0.0319	0.0319	0.0364	0.0410	0.0455	0.0455	0.0455	0.0455	0.0501	0.0501	0.0592	0.0592
BQP-5	0.0346	0.0346	0.0346	0.0411	0.0411	0.0411	0.0475	0.0475	0.0475	0.0540	0.0562	0.0540	0.0605	0.0627	0.0605

Slab: XOREX-50

Test: Concentrated Load at Mid-Span (Figure 5.3-B)

Strain Gage Readings are in $\mu\text{in}/\text{in}$.

Displacement Readings are in inches.

Strain Gage	Load in lbs.															
	0	1215.1	2126.4	2594.4	3940.8	4548.4	5254.5	5771.7	6338.2	6543.5	7142.8	7594.4	8637.1	9146.1	9540.2	10008
QPT-1	0	6.8	11.6	14.6	24.3	28.2	32.0	35.9	39.8	40.8	45.6	48.5	56.3	60.2	63.1	66.0
QPT-2	0	7.8	13.6	17.5	28.1	32.0	37.8	41.7	46.6	48.5	53.4	57.3	66.0	69.9	73.8	77.6
QPT-3	0	7.8	13.6	17.5	28.2	33.0	38.8	42.7	47.6	49.5	55.4	59.2	69.0	72.8	76.7	80.6
QPT-4	0	7.8	13.6	17.5	30.1	34.9	40.8	45.6	50.5	53.4	58.2	62.1	72.8	77.7	80.6	85.4
QPT-5	0	6.8	12.6	15.5	24.2	28.1	33.0	35.9	39.8	41.7	45.6	48.5	56.2	60.1	63.0	66.9
QPT-6	0	5.8	10.7	13.6	21.4	25.2	29.1	32.0	34.9	35.9	39.8	41.7	48.5	51.4	54.4	57.3
MS-1	0	9.7	17.5	21.4	34.0	39.8	45.7	50.5	56.3	58.3	64.1	68.0	78.7	84.5	88.4	93.3
MS-2	0	14.6	25.3	31.1	46.7	54.4	63.2	70.0	76.8	79.7	87.5	93.3	107.9	114.7	120.5	127.3
MS-3	0	-4.4	-8.3	-10.3	-15.9	-18.3	-21.5	-23.9	-26.2	-27.4	-30.1	-32.4	-37.7	-40.1	-42.5	-46.0
MS-4	0	11.7	20.4	25.3	38.9	45.7	53.4	58.3	65.1	67.0	73.8	78.7	91.3	97.2	102.0	108.8
MS-5	N/A	N/A	N/A	N/A	N/A	N/A	N/A	N/A	N/A	N/A	N/A	N/A	N/A	N/A	N/A	N/A
MS-6	0	7.8	15.5	22.3	33.0	37.9	41.8	45.6	49.5	51.5	56.3	60.2	68.9	72.8	75.7	79.6
QPB-1	0	6.8	11.7	13.6	22.3	25.3	30.1	33.0	36.9	37.9	41.8	44.7	51.5	55.4	58.3	61.2
QPB-2	0	6.8	12.6	15.5	23.3	28.2	33.0	35.9	39.8	40.8	44.7	47.6	54.4	58.3	60.2	63.1
QPB-3	0	6.8	11.6	14.5	22.3	26.2	31.0	33.9	37.8	38.8	42.7	45.6	51.4	55.3	57.2	60.1
QPB-4	N/A	N/A	N/A	N/A	N/A	N/A	N/A	N/A	N/A	N/A	N/A	N/A	N/A	N/A	N/A	N/A
QPB-5	0	8.7	15.5	18.4	31.0	36.9	42.7	47.5	53.3	55.3	61.1	65.0	75.6	80.5	84.4	88.3
QPB-6	0	5.8	10.7	13.6	21.3	24.2	29.1	32.0	34.9	36.9	40.7	43.6	50.4	53.3	56.3	59.2
Displacement																
TQP-0	0.0000	0.0000	0.0000	0.0065	0.0065	0.0129	0.0129	0.0151	0.0194	0.0194	0.0216	0.0216	0.0280	0.0280	0.0345	0.0345
tqp-1	0.0000	0.0000	0.0000	0.0000	0.0065	0.0065	0.0130	0.0152	0.0152	0.0195	0.0217	0.0217	0.0282	0.0282	0.0282	0.0347
tqp-2	0.0011	0.0011	0.0044	0.0066	0.0122	0.0144	0.0155	0.0177	0.0210	0.0221	0.0243	0.0265	0.0309	0.0343	0.0354	0.0376
tqp-3	0.0000	0.0000	0.0000	0.0000	0.0022	0.0065	0.0065	0.0129	0.0129	0.0129	0.0129	0.0194	0.0194	0.0258	0.0258	0.0258
tqp-4	0.0000	0.0000	0.0022	0.0043	0.0118	0.0129	0.0161	0.0183	0.0205	0.0205	0.0226	0.0258	0.0280	0.0312	0.0323	0.0366
TQP-5	0.0000	0.0000	0.0000	0.0000	0.0046	0.0138	0.0092	0.0183	0.0183	0.0183	0.0183	0.0229	0.0275	0.0321	0.0321	0.0321
Mid-span-0	0.0021	0.0000	0.0021	0.0021	0.0064	0.0129	0.0107	0.0129	0.0193	0.0193	0.0193	0.0258	0.0279	0.0322	0.0322	0.0343
mid-span-1	0.0000	0.0022	0.0067	0.0045	0.0134	0.0201	0.0201	0.0268	0.0268	0.0290	0.0334	0.0334	0.0401	0.0401	0.0424	0.0468
mid-span-2	0.0000	0.0033	0.0089	0.0100	0.0188	0.0199	0.0255	0.0288	0.0310	0.0332	0.0365	0.0376	0.0443	0.0476	0.0509	0.0531
mid-span-4	0.0000	0.0033	0.0078	0.0100	0.0178	0.0211	0.0245	0.0278	0.0300	0.0311	0.0334	0.0367	0.0434	0.0478	0.0489	0.0500
mid-span-5	0.0022	0.0022	0.0065	0.0065	0.0130	0.0130	0.0216	0.0195	0.0260	0.0260	0.0260	0.0325	0.0368	0.0411	0.0411	0.0476
bqp-1	0.0000	0.0022	0.0066	0.0077	0.0133	0.0155	0.0188	0.0199	0.0232	0.0243	0.0265	0.0287	0.0332	0.0354	0.0365	0.0387
BQP-2	0.0000	0.0000	0.0046	0.0091	0.0137	0.0137	0.0228	0.0228	0.0228	0.0274	0.0274	0.0274	0.0319	0.0319	0.0411	0.0411
BQP-3	0.0000	0.0000	0.0092	0.0092	0.0138	0.0138	0.0229	0.0229	0.0229	0.0275	0.0275	0.0321	0.0367	0.0367	0.0459	0.0459
BQP-4	0.0046	0.0046	0.0046	0.0046	0.0046	0.0091	0.0091	0.0137	0.0182	0.0182	0.0182	0.0228	0.0273	0.0319	0.0273	0.0319
BQP-5	0.0022	0.0022	0.0065	0.0043	0.0130	0.0130	0.0195	0.0195	0.0259	0.0259	0.0259	0.0259	0.0324	0.0324	0.0411	0.0389

Slab: XOREX-50

Test: Concentrated Load at Top Quarter Point (Figure 5.3-C)

Strain Gage Readings are in $\mu\text{in/in}$.

Displacement readings are in inches.

Strain Gage	Load in lbs.												
	0	607.55	1346.4	1986.8	2536.9	3029.5	3620.6	4162.5	4802.9	5385.8	6338.2	7044.3	7487.6
QPT-1	0	2.9	4.9	6.8	8.7	9.7	11.6	13.6	15.5	17.5	20.4	23.3	24.3
QPT-2	0	1.9	4.9	6.8	8.7	9.7	11.6	13.6	15.5	17.5	20.4	23.3	24.3
QPT-3	0	2.9	4.9	7.8	9.7	10.7	13.6	14.6	16.5	19.4	22.3	25.2	27.2
QPT-4	0	1.9	4.9	6.8	8.7	10.7	13.6	15.5	17.5	20.4	24.3	27.2	29.1
QPT-5	0	6.8	14.5	21.3	27.2	32.0	38.8	44.6	51.4	57.2	67.9	75.6	80.5
QPT-6	0	3.9	8.7	12.6	16.5	19.4	23.3	27.2	31.1	35.9	41.7	46.6	50.5
MS-1	0	3.9	7.8	11.7	14.6	17.5	20.4	23.3	27.2	30.1	35.9	39.8	42.7
MS-2	0	3.9	6.8	10.7	13.6	15.6	18.5	20.4	23.3	26.2	30.1	33.0	35.0
MS-3	0	-0.9	-2.1	-2.9	-3.8	-4.4	-5.3	-6.2	-7.1	-8.0	-9.1	-10.0	-10.6
MS-4	0	3.9	7.8	10.7	14.6	16.5	19.4	22.3	25.3	28.2	33.0	36.9	38.9
MS-5	N/A	N/A	N/A	N/A	N/A	N/A	N/A	N/A	N/A	N/A	N/A	N/A	N/A
MS-6	0	3.9	6.8	10.7	13.6	15.5	19.4	21.4	24.3	28.2	32.0	36.9	38.8
QPB-1	0	5.8	11.7	16.5	21.4	25.3	31.1	35.0	40.8	46.6	54.4	61.2	66.1
QPB-2	0	7.8	17.5	27.2	35.0	42.7	51.5	59.2	68.9	78.7	92.3	103.9	111.7
QPB-3	0	6.8	17.5	27.2	35.9	43.7	53.4	62.1	72.8	82.5	97.0	109.6	116.4
QPB-4	N/A	N/A	N/A	N/A	N/A	N/A	N/A	N/A	N/A	N/A	N/A	N/A	N/A
QPB-5	0	2.9	5.8	7.8	9.7	11.6	14.5	16.5	18.4	21.3	25.2	28.1	30.1
QPB-6	0	1.9	3.9	5.8	7.8	8.7	10.7	12.6	14.5	16.5	19.4	21.3	22.3
Displacement													
TQP-0	0.0022	0.0022	0.0022	0.0043	0.0043	0.0043	0.0043	0.0108	0.0108	0.0108	0.0172	0.0172	0.0172
tqp-1	0.0000	0.0000	0.0000	0.0043	0.0065	0.0065	0.0065	0.0152	0.0130	0.0152	0.0217	0.0217	0.0217
tqp-2	0.0000	0.0011	0.0033	0.0066	0.0077	0.0111	0.0122	0.0144	0.0166	0.0199	0.0243	0.0276	0.0287
tqp-3	0.0000	0.0000	0.0000	0.0000	0.0000	0.0000	0.0000	0.0000	0.0065	0.0065	0.0129	0.0129	0.0194
tqp-4	0.0000	0.0000	0.0000	0.0032	0.0065	0.0086	0.0097	0.0118	0.0140	0.0161	0.0194	0.0226	0.0237
TQP-5	0.0000	0.0000	0.0000	0.0046	0.0046	0.0092	0.0138	0.0138	0.0138	0.0183	0.0183	0.0275	0.0275
Mid-span-0	0.0000	0.0000	0.0000	0.0000	0.0021	0.0043	0.0064	0.0064	0.0064	0.0129	0.0129	0.0193	0.0193
mid-span-1	0.0022	0.0022	0.0045	0.0045	0.0045	0.0111	0.0111	0.0111	0.0201	0.0201	0.0245	0.0268	0.0245
mid-span-2	0.0000	0.0000	0.0044	0.0055	0.0089	0.0100	0.0133	0.0155	0.0188	0.0210	0.0255	0.0288	0.0310
mid-span-4	0.0000	0.0011	0.0044	0.0067	0.0089	0.0111	0.0133	0.0156	0.0189	0.0222	0.0256	0.0278	0.0289
mid-span-5	0.0000	0.0000	0.0022	0.0065	0.0065	0.0065	0.0130	0.0130	0.0130	0.0195	0.0195	0.0260	0.0260
bqp-1	0.0011	0.0011	0.0022	0.0033	0.0055	0.0055	0.0066	0.0077	0.0099	0.0122	0.0144	0.0166	0.0177
BQP-2	0.0046	0.0000	0.0000	0.0046	0.0091	0.0091	0.0091	0.0091	0.0137	0.0137	0.0137	0.0228	0.0228
BQP-3	0.0046	0.0000	0.0000	0.0092	0.0092	0.0092	0.0092	0.0138	0.0183	0.0138	0.0183	0.0229	0.0229
BQP-4	0.0046	0.0046	0.0046	0.0046	0.0046	0.0000	0.0046	0.0046	0.0046	0.0046	0.0091	0.0091	0.0137
BQP-5	0.0022	0.0000	0.0000	0.0043	0.0043	0.0043	0.0043	0.0108	0.0108	0.0108	0.0195	0.0195	0.0195

Concentrated Load at Top Quarter Point Continued

	Load in lbs.													
Strain Gage	7963.8	8546.7	8957.3	9729	10065	10566	11288	11625	12307	12643	13284	13612	14326	15016
QPT-1	26.2	27.2	29.1	31.1	33.0	34.0	36.9	37.9	39.8	40.8	43.7	44.7	46.6	49.5
QPT-2	26.2	28.1	31.1	33.0	34.9	35.9	38.8	40.8	42.7	43.7	45.6	47.6	49.5	53.4
QPT-3	29.1	30.1	32.0	34.0	35.9	37.9	40.8	41.8	44.7	45.6	48.6	49.5	51.5	54.4
QPT-4	31.1	33.0	34.9	37.9	39.8	41.7	44.7	46.6	48.5	50.5	53.4	55.3	57.3	61.2
QPT-5	85.3	92.1	96.0	104.7	109.6	116.4	126.1	130.9	139.7	144.5	154.2	160.0	174.6	193.0
QPT-6	53.4	57.3	61.2	66.0	68.9	73.8	79.6	82.5	87.4	90.3	96.1	100.0	107.8	117.5
MS-1	45.7	48.6	50.5	55.4	57.3	60.2	65.1	67.0	70.9	72.9	76.7	78.7	83.5	88.4
MS-2	36.9	39.8	41.8	44.7	45.7	48.6	51.5	53.5	55.4	57.3	60.3	61.2	64.1	67.1
MS-3	-11.2	-12.1	-12.7	-13.3	-13.9	-14.7	-15.6	-15.9	-16.8	-17.1	-18.0	-18.6	-19.2	-19.8
MS-4	41.8	43.7	46.6	50.5	52.5	54.4	58.3	60.2	64.1	66.1	69.0	70.9	73.8	77.7
MS-5	N/A	N/A	N/A	N/A	N/A	N/A	N/A	N/A	N/A	N/A	N/A	N/A	N/A	N/A
MS-6	41.8	44.7	52.4	57.3	58.3	63.1	66.0	67.0	70.9	72.8	76.7	78.7	84.5	98.1
QPB-1	69.9	75.8	79.7	86.5	90.3	95.2	103.9	106.9	114.6	118.5	126.3	132.1	141.8	156.4
QPB-2	119.5	128.2	135.0	147.6	154.4	165.1	174.8	180.6	192.3	199.1	211.7	216.6	229.2	242.8
QPB-3	125.1	134.8	142.6	155.2	162.0	170.7	185.3	191.1	205.7	212.5	227.0	236.7	242.6	248.4
QPB-4	N/A	N/A	N/A	N/A	N/A	N/A	N/A	N/A	N/A	N/A	N/A	N/A	N/A	N/A
QPB-5	32.0	33.9	35.9	38.8	39.8	42.7	45.6	47.5	50.4	51.4	54.3	56.2	58.2	61.1
QPB-6	24.2	26.2	27.2	29.1	30.1	32.0	34.9	35.9	37.8	38.8	40.7	42.7	44.6	47.5
Displacement														
TQP-0	0.0237	0.0237	0.0237	0.0259	0.0323	0.0323	0.0323	0.0323	0.0388	0.0388	0.0366	0.0388	0.0453	0.0453
tqp-1	0.0282	0.0282	0.0282	0.0347	0.0347	0.0347	0.0347	0.0434	0.0434	0.0434	0.0478	0.0499	0.0499	0.0565
tqp-2	0.0321	0.0343	0.0365	0.0398	0.0409	0.0420	0.0453	0.0475	0.0520	0.0531	0.0553	0.0575	0.0619	0.0652
tqp-3	0.0194	0.0194	0.0258	0.0258	0.0258	0.0323	0.0323	0.0323	0.0387	0.0387	0.0452	0.0452	0.0495	0.0516
tqp-4	0.0248	0.0280	0.0312	0.0355	0.0377	0.0388	0.0409	0.0420	0.0441	0.0463	0.0484	0.0495	0.0517	0.0592
TQP-5	0.0275	0.0321	0.0321	0.0367	0.0367	0.0367	0.0459	0.0459	0.0459	0.0459	0.0505	0.0505	0.0505	0.0550
Mid-span-0	0.0193	0.0193	0.0279	0.0258	0.0279	0.0300	0.0322	0.0343	0.0343	0.0408	0.0408	0.0386	0.0451	0.0472
mid-span-1	0.0268	0.0334	0.0334	0.0379	0.0401	0.0401	0.0401	0.0468	0.0468	0.0468	0.0557	0.0535	0.0535	0.0602
mid-span-2	0.0321	0.0343	0.0365	0.0399	0.0410	0.0432	0.0476	0.0487	0.0520	0.0531	0.0554	0.0576	0.0609	0.0642
mid-span-4	0.0311	0.0345	0.0356	0.0411	0.0445	0.0456	0.0467	0.0478	0.0523	0.0545	0.0578	0.0589	0.0623	0.0645
mid-span-5	0.0260	0.0325	0.0325	0.0390	0.0411	0.0390	0.0455	0.0455	0.0455	0.0455	0.0519	0.0541	0.0563	0.0606
bqp-1	0.0188	0.0210	0.0221	0.0243	0.0254	0.0265	0.0287	0.0298	0.0309	0.0321	0.0343	0.0354	0.0376	0.0398
BQP-2	0.0182	0.0228	0.0228	0.0274	0.0274	0.0274	0.0319	0.0365	0.0365	0.0365	0.0411	0.0411	0.0411	0.0456
BQP-3	0.0229	0.0229	0.0321	0.0321	0.0321	0.0367	0.0367	0.0367	0.0367	0.0367	0.0413	0.0459	0.0459	0.0505
BQP-4	0.0182	0.0182	0.0182	0.0228	0.0228	0.0228	0.0228	0.0273	0.0319	0.0273	0.0319	0.0319	0.0364	0.0364
BQP-5	0.0195	0.0259	0.0238	0.0259	0.0259	0.0324	0.0324	0.0324	0.0346	0.0389	0.0389	0.0389	0.0389	0.0454

Slab: XOREX-50

Test: Concentrated Load at Top Third Point (Figure 5.3-D)

Strain Gage Readings are in $\mu\text{in}/\text{in}$.

Displacement Readings are in inches.

Strain Gage	Load in lbs.											
	0	517.24	1387.5	1707.7	2101.8	2504.1	2996.7	3497.5	4146.1	4794.7	5139.5	5747.1
QPT-1	0.0	1.9	5.8	6.8	8.7	10.7	12.6	15.5	18.4	21.4	23.3	26.2
QPT-2	0.0	2.9	6.8	7.8	9.7	11.6	14.6	17.5	21.3	25.2	26.2	30.1
QPT-3	0.0	2.9	7.8	8.7	10.7	12.6	14.6	17.5	21.4	24.3	26.2	30.1
QPT-4	0.0	2.9	7.8	8.7	10.7	12.6	15.5	18.4	22.3	26.2	28.2	33.0
QPT-5	0.0	5.8	14.5	17.5	21.3	25.2	30.1	35.9	42.7	49.5	53.3	60.1
QPT-6	0.0	3.9	9.7	11.6	13.6	16.5	19.4	23.3	28.2	33.0	34.9	39.8
MS-1	0.0	4.9	10.7	12.6	16.5	19.4	23.3	27.2	32.1	36.9	39.8	44.7
MS-2	0.0	3.9	10.7	12.6	15.6	18.5	22.4	25.3	31.1	36.0	37.9	42.8
MS-3	0.0	-1.2	-2.9	-3.8	-4.7	-5.6	-6.8	-8.0	-9.4	-11.2	-12.1	-13.3
MS-4	0.0	3.9	10.7	12.6	15.5	19.4	23.3	27.2	32.1	36.9	39.8	44.7
MS-5	N/A	N/A	N/A	N/A	N/A	N/A	N/A	N/A	N/A	N/A	N/A	N/A
MS-6	0.0	4.9	10.7	17.5	17.5	20.4	24.3	32.0	34.0	37.9	39.8	43.7
QPB-1	0.0	4.9	11.7	14.6	17.5	20.4	25.3	29.1	35.0	39.8	42.7	48.6
QPB-4	0.0	5.8	16.5	20.4	25.2	31.1	36.9	43.7	52.4	61.2	66.0	74.8
QPB-3	0.0	4.8	14.5	18.4	23.3	28.1	33.9	39.8	48.5	56.3	60.1	67.9
QPB-2	N/A	N/A	N/A	N/A	N/A	N/A	N/A	N/A	N/A	N/A	N/A	N/A
QPB-5	0.0	2.9	7.8	8.7	11.6	13.6	16.5	19.4	23.3	27.2	30.1	33.9
QPB-6	0.0	1.9	5.8	5.8	7.8	9.7	11.6	14.5	16.5	19.4	21.3	24.2
Displacement												
TQP-0	0.0000	0.0000	0.0000	0.0000	0.0000	0.0065	0.0065	0.0065	0.0129	0.0129	0.0129	0.0216
tqp-1	0.0000	0.0000	0.0000	0.0000	0.0000	0.0000	0.0065	0.0065	0.0087	0.0152	0.0152	0.0130
tqp-2	0.0000	0.0011	0.0044	0.0055	0.0066	0.0088	0.0111	0.0133	0.0155	0.0177	0.0188	0.0232
tqp-3	0.0000	0.0000	0.0000	0.0000	0.0000	0.0000	0.0000	0.0000	0.0065	0.0065	0.0129	0.0129
tqp-4	0.0000	0.0011	0.0000	0.0000	0.0011	0.0032	0.0075	0.0108	0.0129	0.0151	0.0161	0.0194
TQP-5	0.0000	0.0000	0.0000	0.0000	0.0000	0.0000	0.0046	0.0046	0.0138	0.0138	0.0138	0.0183
Mid-span-0	0.0000	0.0000	0.0000	0.0000	0.0000	0.0000	0.0000	0.0064	0.0064	0.0129	0.0129	0.0129
mid-span-1	0.0022	0.0000	0.0022	0.0045	0.0045	0.0067	0.0067	0.0134	0.0134	0.0201	0.0201	0.0178
mid-span-2	0.0000	0.0000	0.0033	0.0055	0.0089	0.0089	0.0122	0.0155	0.0177	0.0210	0.0221	0.0277
mid-span-4	0.0000	0.0000	0.0033	0.0056	0.0067	0.0089	0.0111	0.0145	0.0167	0.0211	0.0234	0.0267
mid-span-5	0.0000	0.0022	0.0000	0.0022	0.0022	0.0043	0.0065	0.0065	0.0130	0.0130	0.0195	0.0195
bqp-1	0.0000	0.0000	0.0022	0.0033	0.0055	0.0066	0.0077	0.0088	0.0111	0.0133	0.0144	0.0177
BQP-2	0.0046	0.0000	0.0000	0.0000	0.0046	0.0046	0.0091	0.0091	0.0091	0.0137	0.0137	0.0137
BQP-3	0.0000	0.0000	0.0000	0.0046	0.0000	0.0092	0.0092	0.0092	0.0183	0.0138	0.0138	0.0229
BQP-4	0.0000	0.0000	0.0000	0.0046	0.0000	0.0000	0.0000	0.0091	0.0091	0.0091	0.0137	0.0137
BQP-5	0.0022	0.0022	0.0022	0.0022	0.0043	0.0043	0.0043	0.0065	0.0108	0.0130	0.0130	0.0195

Concentrated Load at Top Third Point Continued.

Strain Gage	Load in lbs.													
	6330	7224.9	7775	8177.3	8694.5	8957.3	9597.7	10197	10484	11034	11494	12323	12602	13144
QPT-1	29.1	33.0	35.9	38.8	40.8	42.7	45.6	48.5	49.5	52.4	55.3	59.2	60.2	63.1
QPT-2	33.0	37.8	40.8	42.7	45.6	47.6	50.5	53.4	55.3	58.2	60.2	64.1	65.0	67.9
QPT-3	34.0	38.8	41.8	44.7	47.6	48.6	52.4	56.3	57.3	60.2	62.2	67.0	68.0	70.9
QPT-4	35.9	41.7	45.6	47.6	51.5	53.4	57.3	61.2	63.1	66.0	68.0	72.8	74.8	77.7
QPT-5	67.9	79.5	86.3	91.2	98.9	101.8	111.5	118.3	122.2	131.9	139.7	154.2	161.0	175.6
QPT-6	43.7	51.4	56.3	59.2	64.1	67.0	74.7	81.5	84.5	91.3	98.0	109.7	115.5	123.3
MS-1	49.5	57.3	62.2	66.1	70.9	73.8	78.7	84.5	87.4	92.3	97.1	104.9	106.9	110.7
MS-2	46.7	53.5	57.3	60.3	63.2	64.1	68.0	71.9	73.9	77.8	80.7	86.5	87.5	92.3
MS-3	-14.7	-16.8	-18.0	-18.6	-19.8	-20.1	-21.2	-22.4	-22.7	-23.9	-24.2	-25.4	-25.7	-26.2
MS-4	49.6	57.3	62.2	65.1	69.0	71.9	76.8	81.6	83.6	87.5	90.4	96.2	98.1	102.0
MS-5	N/A	N/A	N/A	N/A	N/A	N/A	N/A	N/A	N/A	N/A	N/A	N/A	N/A	N/A
MS-6	46.6	53.4	57.3	61.2	65.1	68.0	72.8	78.7	80.6	85.5	89.3	96.1	101.0	105.8
QPB-1	53.4	62.2	68.0	72.9	82.6	86.5	95.2	103.0	106.9	113.7	120.5	134.1	138.9	158.3
QPB-4	83.5	97.1	102.9	106.8	114.6	119.4	142.8	161.2	168.0	182.6	200.1	230.2	244.7	265.1
QPB-3	74.7	85.4	91.2	96.0	99.9	102.8	109.6	121.3	126.1	138.7	173.6	236.7	252.2	270.7
QPB-2	N/A	N/A	N/A	N/A	N/A	N/A	N/A	N/A	N/A	N/A	N/A	N/A	N/A	N/A
QPB-5	37.8	43.6	46.6	49.5	53.3	55.3	59.2	63.0	65.0	67.9	70.8	75.6	77.6	80.5
QPB-6	27.2	31.0	33.9	35.9	37.8	39.8	42.7	45.6	47.5	49.5	51.4	56.3	57.2	60.1
Displacement														
TQP-0	0.0194	0.0194	0.0259	0.0259	0.0259	0.0280	0.0323	0.0323	0.0323	0.0409	0.0388	0.0474	0.0453	0.0453
tqp-1	0.0217	0.0217	0.0282	0.0282	0.0282	0.0282	0.0369	0.0347	0.0347	0.0434	0.0434	0.0499	0.0499	0.0565
tqp-2	0.0254	0.0309	0.0332	0.0354	0.0387	0.0398	0.0442	0.0464	0.0475	0.0508	0.0542	0.0608	0.0630	0.0674
tqp-3	0.0172	0.0194	0.0237	0.0258	0.0258	0.0301	0.0323	0.0409	0.0409	0.0409	0.0473	0.0538	0.0538	0.0602
tqp-4	0.0215	0.0248	0.0269	0.0291	0.0323	0.0355	0.0398	0.0420	0.0431	0.0452	0.0484	0.0528	0.0538	0.0603
TQP-5	0.0183	0.0275	0.0275	0.0275	0.0321	0.0321	0.0413	0.0413	0.0413	0.0459	0.0459	0.0550	0.0505	0.0596
Mid-span-0	0.0193	0.0215	0.0279	0.0258	0.0279	0.0300	0.0322	0.0343	0.0408	0.0408	0.0408	0.0472	0.0472	0.0558
mid-span-1	0.0268	0.0245	0.0334	0.0334	0.0401	0.0401	0.0401	0.0468	0.0468	0.0468	0.0535	0.0602	0.0624	0.0602
mid-span-2	0.0310	0.0343	0.0376	0.0399	0.0432	0.0443	0.0498	0.0520	0.0531	0.0565	0.0598	0.0653	0.0675	0.0709
mid-span-4	0.0289	0.0322	0.0356	0.0378	0.0411	0.0456	0.0478	0.0489	0.0512	0.0556	0.0589	0.0645	0.0667	0.0712
mid-span-5	0.0260	0.0260	0.0325	0.0325	0.0325	0.0390	0.0390	0.0455	0.0476	0.0455	0.0541	0.0606	0.0584	0.0606
bqp-1	0.0188	0.0232	0.0243	0.0265	0.0276	0.0287	0.0309	0.0332	0.0343	0.0365	0.0387	0.0431	0.0442	0.0464
BQP-2	0.0228	0.0228	0.0274	0.0274	0.0274	0.0274	0.0319	0.0319	0.0319	0.0411	0.0411	0.0456	0.0456	0.0456
BQP-3	0.0229	0.0229	0.0321	0.0275	0.0321	0.0367	0.0367	0.0367	0.0367	0.0459	0.0413	0.0505	0.0505	0.0505
BQP-4	0.0137	0.0228	0.0228	0.0228	0.0273	0.0273	0.0273	0.0364	0.0364	0.0319	0.0364	0.0410	0.0410	0.0455
BQP-5	0.0195	0.0259	0.0259	0.0259	0.0259	0.0324	0.0324	0.0324	0.0389	0.0389	0.0389	0.0454	0.0454	0.0454

Slab: XOREX-50

Test: Concentrated Load at Bottom Third Point (Figure 5.3-E)

Strain Gage Readings are in $\mu\text{in}/\text{in}$.

Displacement Readings are in inches.

Strain Gage	Load in lbs									
	0	1510.6	2003.2	2536.9	3128	3645.3	4072.2	4778.3	5615.7	6346.4
QPT-1	0	10.7	14.6	19.4	24.3	28.2	32.0	37.9	45.6	51.4
QPT-2	0	16.5	22.3	28.1	35.9	42.7	47.6	56.3	67.9	77.6
QPT-3	0	17.5	24.3	31.1	39.8	47.6	53.4	63.1	75.7	87.4
QPT-4	0	15.5	21.4	28.2	35.9	42.7	49.5	58.2	69.9	80.6
QPT-5	0	5.8	7.8	9.7	12.6	14.5	16.5	19.4	23.3	26.2
QPT-6	0	5.8	7.8	9.7	11.6	13.6	15.5	18.4	21.4	25.2
MS-1	0	9.7	13.6	17.5	22.3	26.2	30.1	35.0	40.8	46.6
MS-2	0	9.7	12.6	16.5	21.4	25.3	28.2	33.0	39.8	44.7
MS-3	0	-3.2	-4.1	-5.3	-6.8	-8.0	-8.8	-10.3	-12.1	-13.6
MS-4	0	9.7	12.6	17.5	21.4	25.3	28.2	34.0	39.8	45.7
MS-5	N/A	N/A	N/A	N/A	N/A	N/A	N/A	N/A	N/A	N/A
MS-6	0	9.7	12.6	15.5	19.4	22.3	25.2	30.1	35.9	40.8
QPB-1	0	5.8	7.8	9.7	11.7	13.6	15.5	18.5	22.3	25.3
QPB-4	0	5.8	7.8	9.7	12.6	14.6	16.5	19.4	23.3	26.2
QPB-3	0	5.8	7.8	9.7	12.6	14.5	16.5	19.4	22.3	25.2
QPB-2	N/A	N/A	N/A	N/A	N/A	N/A	N/A	N/A	N/A	N/A
QPB-5	0	15.5	21.3	28.1	35.9	42.7	47.5	57.2	67.9	77.6
QPB-6	0	8.7	11.6	14.5	19.4	22.3	25.2	30.1	35.9	41.7
Displacement										
TQP-0	0	0.0022	0.0000	0.0022	0.0086	0.0086	0.0086	0.0086	0.0151	0.0151
tqp-1	0	0.0000	0.0000	0.0000	0.0022	0.0065	0.0065	0.0065	0.0109	0.0130
tqp-2	0	0.0033	0.0044	0.0055	0.0077	0.0099	0.0111	0.0133	0.0155	0.0177
tqp-3	0	0.0000	0.0000	0.0000	0.0000	0.0000	0.0000	0.0000	0.0065	0.0065
tqp-4	0	0.0000	0.0000	0.0011	0.0043	0.0075	0.0086	0.0118	0.0140	0.0172
TQP-5	0	0.0000	0.0046	0.0046	0.0046	0.0092	0.0092	0.0092	0.0183	0.0183
Mid-span-0	0	0.0000	0.0000	0.0000	0.0064	0.0043	0.0064	0.0129	0.0129	0.0193
mid-span-1	0	0.0067	0.0134	0.0134	0.0134	0.0223	0.0223	0.0290	0.0290	0.0334
mid-span-2	0	0.0044	0.0066	0.0100	0.0133	0.0155	0.0166	0.0199	0.0255	0.0288
mid-span-4	0	0.0044	0.0078	0.0100	0.0133	0.0156	0.0178	0.0211	0.0256	0.0289
mid-span-5	0	0.0022	0.0000	0.0065	0.0065	0.0065	0.0130	0.0130	0.0216	0.0195
bqp-1	0	0.0033	0.0066	0.0077	0.0088	0.0111	0.0144	0.0177	0.0199	0.0232
BQP-2	0	0.0000	0.0000	0.0046	0.0046	0.0137	0.0137	0.0182	0.0182	0.0274
BQP-3	0	0.0000	0.0092	0.0092	0.0092	0.0138	0.0138	0.0229	0.0229	0.0275
BQP-4	0	0.0000	0.0000	0.0046	0.0091	0.0091	0.0137	0.0137	0.0228	0.0228
BQP-5	0	0.0000	0.0065	0.0065	0.0108	0.0130	0.0130	0.0195	0.0195	0.0259

Concentrated Load at Bottom Third Point Continued.

Strain Gage	Load in lbs.											
	6970.4	7750.4	8300.4	9072.2	9589.4	10311	10648	11288	11814	12093	12619	13177
QPT-1	57.3	64.1	68.9	76.7	81.5	88.3	91.3	98.0	103.9	106.8	111.6	118.4
QPT-2	86.4	97.0	104.8	115.5	122.3	133.0	137.8	147.5	155.3	159.2	167.9	174.7
QPT-3	97.1	109.7	118.5	130.1	138.9	148.6	151.5	159.3	167.1	170.9	179.7	186.5
QPT-4	89.3	101.0	108.7	119.4	127.2	137.9	142.7	152.4	160.2	165.1	171.9	182.5
QPT-5	29.1	33.0	34.9	37.8	40.7	43.6	44.6	47.5	50.4	51.4	53.3	56.2
QPT-6	27.2	30.1	32.0	35.9	39.8	43.7	44.7	47.6	50.5	51.4	54.4	56.3
MS-1	51.5	58.3	62.2	69.0	72.9	78.7	82.6	88.4	93.3	96.2	101.0	107.8
MS-2	48.6	54.4	58.3	63.2	67.1	70.9	72.9	75.8	78.7	80.7	84.6	93.3
MS-3	-15.0	-16.5	-17.7	-19.5	-20.6	-21.8	-22.1	-23.0	-24.2	-24.8	-25.7	-26.5
MS-4	50.5	55.4	60.2	66.1	70.0	75.8	77.7	83.6	87.5	90.4	94.3	99.1
MS-5	N/A	N/A	N/A	N/A	N/A	N/A	N/A	N/A	N/A	N/A	N/A	N/A
MS-6	44.7	49.5	53.4	63.1	70.9	79.6	82.5	87.4	91.3	93.2	97.1	101.0
QPB-1	28.2	31.1	34.0	36.9	38.9	42.7	43.7	46.6	49.5	50.5	53.4	55.4
QPB-4	29.1	32.0	35.0	37.9	39.8	42.7	43.7	46.6	48.6	49.5	51.5	53.4
QPB-3	28.1	31.0	33.0	36.9	38.8	41.7	42.7	44.6	46.6	47.5	49.5	51.4
QPB-2	N/A	N/A	N/A	N/A	N/A	N/A	N/A	N/A	N/A	N/A	N/A	N/A
QPB-5	86.3	97.0	104.7	115.4	123.2	133.8	138.7	149.4	157.1	161.0	168.8	179.4
QPB-6	45.6	51.4	55.3	61.1	65.0	70.8	73.7	79.5	83.4	86.3	91.2	96.0
Displacement												
TQP-0	0.0151	0.0216	0.0216	0.0216	0.0280	0.0280	0.0280	0.0345	0.0345	0.0345	0.0345	0.0431
tqp-1	0.0130	0.0195	0.0217	0.0217	0.0217	0.0282	0.0282	0.0282	0.0347	0.0347	0.0347	0.0347
tqp-2	0.0188	0.0232	0.0243	0.0276	0.0298	0.0332	0.0343	0.0365	0.0387	0.0398	0.0420	0.0442
tqp-3	0.0129	0.0129	0.0129	0.0194	0.0194	0.0194	0.0237	0.0258	0.0258	0.0258	0.0344	0.0323
tqp-4	0.0183	0.0215	0.0226	0.0258	0.0269	0.0291	0.0301	0.0334	0.0366	0.0388	0.0409	0.0420
TQP-5	0.0229	0.0229	0.0229	0.0275	0.0275	0.0367	0.0367	0.0367	0.0367	0.0413	0.0413	0.0413
Mid-span-0	0.0193	0.0258	0.0258	0.0258	0.0322	0.0343	0.0322	0.0386	0.0408	0.0408	0.0472	0.0472
mid-span-1	0.0357	0.0424	0.0424	0.0468	0.0491	0.0513	0.0557	0.0557	0.0624	0.0624	0.0624	0.0691
mid-span-2	0.0321	0.0354	0.0388	0.0421	0.0454	0.0487	0.0509	0.0543	0.0565	0.0587	0.0609	0.0642
mid-span-4	0.0311	0.0345	0.0378	0.0423	0.0478	0.0489	0.0500	0.0545	0.0578	0.0589	0.0623	0.0656
mid-span-5	0.0281	0.0260	0.0325	0.0325	0.0390	0.0390	0.0411	0.0476	0.0476	0.0541	0.0541	0.0541
bqp-1	0.0265	0.0298	0.0321	0.0354	0.0376	0.0409	0.0420	0.0453	0.0475	0.0497	0.0520	0.0553
BQP-2	0.0274	0.0319	0.0319	0.0411	0.0411	0.0456	0.0456	0.0547	0.0547	0.0547	0.0593	0.0593
BQP-3	0.0275	0.0367	0.0367	0.0459	0.0459	0.0505	0.0505	0.0596	0.0596	0.0596	0.0642	0.0642
BQP-4	0.0273	0.0273	0.0273	0.0319	0.0364	0.0410	0.0410	0.0455	0.0455	0.0455	0.0501	0.0546
BQP-5	0.0259	0.0346	0.0346	0.0411	0.0411	0.0389	0.0475	0.0475	0.0475	0.0540	0.0540	0.0562

Slab: XOREX-50

Test: Longitudinal Linear Load Along Middle Strip (Figure 5.3-F)

Strain Gage Readings are in $\mu\text{in}/\text{in}$.

Displacement readings are in inches.

Strain Gage	Load in lbs.												
	0	1215.1	2011.4	3136.2	4211.8	4991.7	6157.6	7019.7	8308.7	9154.3	9983.5	11338	12060
QPT-1	0	7.8	13.6	21.4	29.1	34.9	43.7	50.5	60.2	67.0	72.8	84.5	91.3
QPT-2	0	8.7	15.5	24.3	34.0	40.8	51.4	59.2	69.9	76.7	83.5	94.1	99.0
QPT-3	0	9.7	16.5	27.2	36.9	44.7	56.3	64.1	77.7	84.5	92.3	102.9	108.8
QPT-4	0	9.7	17.5	28.2	38.8	46.6	58.3	67.0	80.6	88.4	97.1	109.7	115.5
QPT-5	0	11.6	21.3	38.8	55.3	67.9	86.3	98.9	117.3	128.0	138.7	155.2	163.9
QPT-6	0	8.7	14.6	25.2	35.9	43.7	56.3	65.0	78.6	87.4	96.1	112.6	123.3
MS-1	0	19.4	35.0	62.2	87.4	105.9	134.1	155.5	189.5	212.8	238.1	286.7	320.7
MS-2	0	20.4	36.9	65.1	94.3	115.7	146.8	170.1	203.2	225.5	248.9	293.6	329.6
MS-3	0	-6.5	-11.8	-20.3	-28.6	-34.8	-44.2	-51.0	-61.9	-69.6	-78.4	-89.6	-93.8
MS-4	0	21.4	39.8	68.0	97.2	118.6	152.6	177.9	218.7	245.9	275.1	324.7	350.9
MS-5	N/A	N/A	N/A	N/A	N/A	N/A	N/A	N/A	N/A	N/A	N/A	N/A	N/A
MS-6	0	14.6	27.2	48.6	69.0	84.5	105.9	122.4	146.7	162.2	178.7	212.7	238.0
QPB-1	0	10.7	19.4	35.0	49.5	61.2	78.7	92.3	114.6	129.2	145.7	174.9	195.3
QPB-2	0	12.6	23.3	39.8	57.3	68.9	87.4	101.0	122.4	136.9	152.5	180.6	195.2
QPB-3	0	11.6	22.3	38.8	57.2	69.8	90.2	104.8	127.1	140.7	155.2	181.4	196.9
QPB-4	N/A	N/A	N/A	N/A	N/A	N/A	N/A	N/A	N/A	N/A	N/A	N/A	N/A
QPB-5	0	11.6	18.4	30.1	41.7	49.5	62.1	70.8	84.4	93.1	101.8	115.4	121.2
QPB-6	0	7.8	12.6	19.4	26.2	31.0	38.8	43.6	52.4	57.2	63.0	71.8	74.7
Displacement													
TQP-0	0	0.0065	0.0065	0.0129	0.0194	0.0259	0.0323	0.0345	0.0409	0.0474	0.0539	0.0603	0.0668
tqp-1	0	0.0000	0.0000	0.0087	0.0152	0.0217	0.0282	0.0369	0.0434	0.0499	0.0499	0.0651	0.0717
tqp-2	0	0.0055	0.0099	0.0177	0.0243	0.0287	0.0376	0.0442	0.0497	0.0564	0.0641	0.0741	0.0807
tqp-3	0	0.0000	0.0000	0.0065	0.0129	0.0194	0.0258	0.0344	0.0409	0.0473	0.0538	0.0667	0.0731
tqp-4	0	0.0000	0.0043	0.0108	0.0215	0.0248	0.0334	0.0409	0.0484	0.0549	0.0624	0.0754	0.0818
TQP-5	0	0.0046	0.0046	0.0183	0.0229	0.0321	0.0367	0.0459	0.0596	0.0642	0.0688	0.0826	0.0872
Mid-span-0	0	0.0000	0.0064	0.0129	0.0193	0.0258	0.0343	0.0408	0.0558	0.0622	0.0687	0.0751	0.0880
mid-span-1	0	0.0067	0.0156	0.0223	0.0290	0.0357	0.0491	0.0557	0.0624	0.0691	0.0803	0.0936	0.1026
mid-span-2	0	0.0055	0.0111	0.0221	0.0299	0.0365	0.0454	0.0543	0.0653	0.0731	0.0853	0.0996	0.1118
mid-span-4	0	0.0056	0.0100	0.0234	0.0334	0.0400	0.0512	0.0589	0.0712	0.0790	0.0879	0.1034	0.1157
mid-span-5	0	0.0043	0.0043	0.0173	0.0238	0.0303	0.0455	0.0519	0.0649	0.0714	0.0844	0.0996	0.1125
bqp-1	0	0.0033	0.0077	0.0144	0.0199	0.0243	0.0321	0.0376	0.0453	0.0497	0.0553	0.0652	0.0718
BQP-2	0	0.0046	0.0046	0.0137	0.0228	0.0228	0.0365	0.0411	0.0502	0.0547	0.0639	0.0684	0.0776
BQP-3	0	0.0000	0.0092	0.0138	0.0229	0.0275	0.0367	0.0413	0.0505	0.0596	0.0642	0.0734	0.0872
BQP-4	0	0.0000	0.0046	0.0137	0.0182	0.0228	0.0319	0.0364	0.0455	0.0546	0.0592	0.0683	0.0728
BQP-5	0	0.0043	0.0086	0.0173	0.0238	0.0303	0.0367	0.0432	0.0519	0.0584	0.0648	0.0713	0.0843

Slab: XOREX-50

Test: Longitudinal Linear Load along Left Third Strip (Figure 5.3-G)

Strain Gage Readings are in $\mu\text{in}/\text{in}$.

Displacement Readings are in inches.

Strain Gage	Load in lbs.																
	0	1338.2	1986.8	2561.5	3087	3645.3	4236.4	4638.7	5270.9	6149.4	7159.2	8070.6	8924.4	10049	11141	11855	12545
QPT-1	0	10.7	16.5	21.4	27.2	32.0	37.9	41.7	47.6	55.3	65.0	72.8	80.6	89.3	96.1	99.0	99.0
QPT-2	0	10.7	15.5	20.4	25.2	30.1	34.9	37.8	43.7	51.4	60.2	67.9	75.7	85.4	95.1	100.9	102.9
QPT-3	0	9.7	15.5	20.4	24.3	29.1	34.0	37.9	43.7	51.5	60.2	68.0	75.7	88.4	101.0	109.7	121.4
QPT-4	0	8.7	13.6	17.5	22.3	26.2	31.1	34.9	39.8	46.6	54.4	62.1	69.9	81.6	94.2	102.9	117.5
QPT-5	0	7.8	11.6	15.5	18.4	23.3	27.2	30.1	34.9	40.7	48.5	54.3	61.1	68.9	79.5	87.3	95.0
QPT-6	0	4.9	7.8	10.7	12.6	15.5	19.4	21.4	24.3	29.1	34.9	40.8	46.6	54.4	65.0	70.9	44.7
MS-1	0	18.5	29.1	37.9	45.7	54.4	64.1	70.9	81.6	95.2	111.7	131.1	228.3	306.1	393.5	444.1	492.7
MS-2	0	17.5	25.3	33.0	38.9	46.7	54.4	59.3	68.0	78.7	92.3	105.9	125.4	162.3	221.6	231.4	285.8
MS-3	0	-4.4	-6.5	-8.3	-9.7	-11.5	-13.3	-14.7	-16.5	-19.2	-22.4	-25.4	-28.9	-34.2	-42.8	-56.3	-66.9
MS-4	0	9.7	15.5	20.4	24.3	29.1	34.0	36.9	41.8	49.6	57.3	65.1	73.8	86.5	104.0	119.5	141.9
MS-5	N/A	N/A	N/A	N/A	N/A	N/A	N/A	N/A	N/A	N/A	N/A	N/A	N/A	N/A	N/A	N/A	N/A
MS-6	0	7.8	10.7	13.6	16.5	20.4	23.3	25.2	29.1	34.0	39.8	45.6	51.5	59.2	68.9	76.7	94.2
QPB-1	0	13.6	20.4	28.2	35.0	42.7	51.5	57.3	67.0	79.7	95.2	107.8	119.5	133.1	141.8	145.7	217.6
QPB-2	0	11.7	18.4	24.3	29.1	35.0	40.8	45.6	52.4	59.2	68.9	77.7	87.4	100.0	124.3	144.7	186.5
QPB-3	0	9.7	15.5	20.4	25.2	30.1	34.9	38.8	45.6	53.4	63.1	72.8	82.5	95.1	108.6	120.3	145.5
QPB-4	N/A	N/A	N/A	N/A	N/A	N/A	N/A	N/A	N/A	N/A	N/A	N/A	N/A	N/A	N/A	N/A	N/A
QPB-5	0	8.7	13.6	17.5	22.3	26.2	31.0	33.9	39.8	46.6	54.3	62.1	70.8	82.4	95.0	105.7	123.2
QPB-6	0	4.8	7.8	9.7	11.6	14.5	17.5	18.4	21.3	25.2	30.1	33.9	38.8	44.6	51.4	57.2	66.0
Displacement																	
TQP-0	0.0000	0.0043	0.0129	0.0194	0.0237	0.0259	0.0323	0.0323	0.0409	0.0453	0.0539	0.0603	0.0668	0.0733	0.0862	0.0927	0.1056
tqp-1	0.0022	0.0000	0.0065	0.0065	0.0152	0.0152	0.0217	0.0217	0.0282	0.0347	0.0434	0.0478	0.0499	0.0630	0.0717	0.0782	0.0934
tqp-2	0.0000	0.0033	0.0066	0.0099	0.0133	0.0166	0.0210	0.0232	0.0276	0.0309	0.0376	0.0431	0.0475	0.0564	0.0619	0.0718	0.0829
tqp-3	0.0000	0.0022	0.0022	0.0022	0.0022	0.0022	0.0065	0.0065	0.0151	0.0129	0.0215	0.0280	0.0323	0.0409	0.0452	0.0538	
tqp-4	0.0000	0.0000	0.0000	0.0000	0.0011	0.0022	0.0043	0.0054	0.0075	0.0097	0.0129	0.0151	0.0172	0.0215	0.0291	0.0334	0.0366
TQP-5	0.0000	0.0000	0.0000	0.0000	0.0000	0.0000	0.0046	0.0092	0.0046	0.0092	0.0138	0.0138	0.0138	0.0183	0.0275	0.0275	0.0321
Mid-span-0	0.0021	0.0043	0.0043	0.0107	0.0172	0.0258	0.0300	0.0322	0.0386	0.0451	0.0515	0.0665	0.0730	0.0858	0.0987	0.1137	0.1395
mid-span-1	0.0000	0.0134	0.0201	0.0201	0.0268	0.0334	0.0424	0.0401	0.0491	0.0535	0.0624	0.0691	0.0758	0.0892	0.1026	0.1159	0.1449
mid-span-2	0.0011	0.0066	0.0111	0.0155	0.0188	0.0221	0.0266	0.0288	0.0343	0.0410	0.0465	0.0531	0.0587	0.0686	0.0819	0.0908	0.1151
mid-span-4	0.0000	0.0011	0.0033	0.0056	0.0067	0.0089	0.0111	0.0133	0.0156	0.0189	0.0222	0.0256	0.0300	0.0389	0.0423	0.0467	0.0556
mid-span-5	0.0022	0.0000	0.0022	0.0043	0.0065	0.0065	0.0065	0.0065	0.0130	0.0130	0.0195	0.0195	0.0238	0.0260	0.0325	0.0325	0.0390
bqp-1	0.0000	0.0066	0.0111	0.0166	0.0199	0.0232	0.0276	0.0298	0.0343	0.0398	0.0464	0.0520	0.0586	0.0663	0.0774	0.0851	0.0984
BQP-2	0.0000	0.0046	0.0091	0.0091	0.0137	0.0137	0.0228	0.0228	0.0274	0.0274	0.0365	0.0411	0.0456	0.0547	0.0593	0.0684	0.0821
BQP-3	0.0000	0.0046	0.0092	0.0092	0.0092	0.0183	0.0183	0.0183	0.0229	0.0229	0.0321	0.0367	0.0367	0.0459	0.0505	0.0596	0.0688
BQP-4	0.0000	0.0000	0.0000	0.0000	0.0000	0.0000	0.0000	0.0000	0.0000	0.0046	0.0046	0.0091	0.0137	0.0182	0.0273	0.0228	0.0319
BQP-5	0.0000	0.0000	0.0000	0.0022	0.0065	0.0065	0.0065	0.0065	0.0065	0.0130	0.0151	0.0151	0.0216	0.0216	0.0281	0.0281	0.0346

Slab: XOREX-50

Test: Longitudinal Linear Load along Right Third Strip (Figure 5.3-H)

Strain Gage Readings are in $\mu\text{in}/\text{in}$.

Displacement Readings are in inches.

Strain Gage	Load in lbs.											
	0	1091.9	2077.1	3144.4	4228.2	5000	6124.7	7003.2	8119.8	8957.3	10106	10640
QPT-1	0	4.9	10.7	16.5	22.3	26.2	32.0	36.9	43.7	48.5	56.3	64.1
QPT-2	0	7.8	16.5	24.3	34.0	39.8	49.5	56.3	66.0	73.8	85.4	94.1
QPT-3	0	9.7	18.5	29.1	38.8	46.6	57.3	66.0	76.7	85.5	96.1	101.0
QPT-4	0	11.6	22.3	35.0	47.6	56.3	69.9	79.6	92.2	101.9	112.6	114.6
QPT-5	0	9.7	20.4	32.0	45.6	55.3	69.8	80.5	95.0	103.8	113.5	170.7
QPT-6	0	14.6	29.1	45.6	60.2	70.9	86.4	98.1	111.6	121.4	133.0	169.9
MS-1	0	9.7	19.4	31.1	45.7	55.4	71.9	84.5	103.0	119.5	147.7	179.8
MS-2	0	12.6	25.3	40.8	57.3	69.0	87.5	102.1	122.5	142.9	179.8	220.7
MS-3	0	-4.7	-9.1	-14.2	-19.5	-23.0	-28.6	-33.3	-39.8	-46.9	-59.0	-82.3
MS-4	0	17.5	34.0	51.5	70.0	83.6	103.0	118.6	139.9	288.7	406.3	446.2
MS-5	N/A	N/A	N/A	N/A	N/A	N/A	N/A	N/A	N/A	N/A	N/A	N/A
MS-6	0	13.6	26.2	39.8	55.4	66.0	81.6	95.2	132.1	191.3	251.6	307.9
QPB-1	0	5.8	11.7	19.4	28.2	34.0	44.7	53.4	66.1	75.8	94.2	111.7
QPB-2	0	9.7	18.4	30.1	41.8	50.5	64.1	74.8	88.4	101.0	121.4	139.8
QPB-3	0	10.7	21.3	33.9	47.5	57.2	70.8	81.5	96.0	108.6	134.8	155.2
QPB-4	N/A	N/A	N/A	N/A	N/A	N/A	N/A	N/A	N/A	N/A	N/A	N/A
QPB-5	0	11.6	22.3	34.9	47.5	57.2	70.8	80.5	94.1	102.8	113.5	114.4
QPB-6	0	9.7	17.5	28.1	38.8	46.6	57.2	66.9	77.6	83.4	92.1	91.2
Displacement												
TQP-0	0	0.0000	0.0000	0.0000	0.0000	0.0000	0.0022	0.0065	0.0065	0.0129	0.0129	0.0194
tqp-1	0	0.0000	0.0000	0.0022	0.0065	0.0087	0.0152	0.0130	0.0217	0.0217	0.0282	0.0347
tqp-2	0	0.0033	0.0066	0.0122	0.0177	0.0221	0.0265	0.0309	0.0365	0.0420	0.0497	0.0542
tqp-3	0	0.0000	0.0000	0.0065	0.0129	0.0215	0.0280	0.0301	0.0409	0.0473	0.0538	0.0667
tqp-4	0	0.0043	0.0118	0.0205	0.0312	0.0355	0.0431	0.0538	0.0581	0.0678	0.0807	0.0915
TQP-5	0	0.0138	0.0183	0.0321	0.0459	0.0505	0.0596	0.0642	0.0780	0.0826	0.0963	0.1101
Mid-span-0	0	0.0000	0.0000	0.0021	0.0000	0.0000	0.0000	0.0064	0.0064	0.0129	0.0193	0.0258
mid-span-1	0	0.0067	0.0067	0.0134	0.0134	0.0223	0.0201	0.0268	0.0357	0.0424	0.0468	0.0557
mid-span-2	0	0.0022	0.0078	0.0133	0.0199	0.0255	0.0310	0.0365	0.0432	0.0487	0.0587	0.0709
mid-span-4	0	0.0100	0.0200	0.0311	0.0400	0.0500	0.0601	0.0689	0.0790	0.0901	0.1056	0.1257
mid-span-5	0	0.0065	0.0195	0.0325	0.0390	0.0519	0.0606	0.0736	0.0801	0.0931	0.1104	0.1342
bqp-1	0	0.0000	0.0011	0.0033	0.0066	0.0099	0.0133	0.0155	0.0199	0.0232	0.0287	0.0332
BQP-2	0	0.0000	0.0000	0.0046	0.0137	0.0137	0.0182	0.0274	0.0319	0.0411	0.0456	0.0547
BQP-3	0	0.0000	0.0092	0.0138	0.0229	0.0275	0.0367	0.0459	0.0505	0.0596	0.0642	0.0734
BQP-4	0	0.0000	0.0137	0.0182	0.0273	0.0319	0.0410	0.0455	0.0546	0.0592	0.0728	0.0865
BQP-5	0	0.0108	0.0195	0.0324	0.0389	0.0475	0.0540	0.0648	0.0735	0.0800	0.0929	0.1059

Slab: XOREX-50

Test: Transverse Linear Load Across Mid-Span (Figure 5.3-I)

Strain Gage Readings are in $\mu\text{in/in}$.

Displacement Readings are in inches.

Strain Gage	Load in lbs.																	Fail
	1206.8	1945.8	3021.3	4006.5	5016.4	6272.5	7307	7298.8	7963.8	9252.8	10911	12027	12857	13029	13193	13341	13423	
QPT-1	7.8	13.6	21.4	28.2	36.9	46.6	54.4	54.4	59.2	69.9	83.5	93.2	100.0	85.4	84.5	131.1	151.4	232.0
QPT-2	8.7	14.6	24.3	33.0	41.7	52.4	62.1	62.1	67.9	78.6	92.2	100.9	105.8	204.8	212.6	243.6	245.6	253.3
QPT-3	9.7	16.5	26.2	35.9	45.6	58.3	68.0	68.0	74.8	86.4	102.0	110.7	115.6	169.0	175.8	213.7	218.5	228.3
QPT-4	9.7	16.5	27.2	36.9	47.6	60.2	69.9	69.9	77.7	90.3	106.8	116.5	123.3	130.1	130.1	125.2	150.5	167.0
QPT-5	13.6	25.2	44.6	61.1	75.6	94.1	108.6	108.6	116.4	132.9	155.2	171.7	186.2	261.9	270.6	281.3	283.2	290.0
QPT-6	9.7	17.5	29.1	38.8	49.5	62.1	72.8	72.8	79.6	93.2	111.6	128.1	146.6	212.6	215.5	224.3	231.1	246.6
MS-1	21.4	38.9	68.0	95.2	122.4	157.4	186.6	186.6	205.1	242.0	292.5	338.2	394.6	616.4	661.1	782.8	826.6	898.6
MS-2	22.4	40.8	71.9	101.1	131.2	168.2	198.3	198.3	217.8	255.7	308.2	359.8	453.1	778.2	812.3	925.2	968.1	1041.1
MS-3	-6.8	-12.4	-21.5	-30.4	-39.5	-50.7	-59.9	-59.9	-65.8	-77.3	-93.5	-108.5	-131.8	-234.4	-250.3	-289.2	-302.2	-326.9
MS-4	23.3	43.7	74.8	105.0	137.0	177.9	211.9	211.9	233.3	276.1	333.4	389.8	489.1	785.8	842.3	963.0	1002.9	1075.0
MS-5	N/A	N/A	N/A	N/A	N/A	N/A	N/A	N/A	N/A	N/A	N/A	N/A	N/A	N/A	N/A	N/A	N/A	N/A
MS-6	16.5	30.1	51.5	70.9	90.3	114.6	134.0	134.0	146.7	171.9	207.9	246.7	296.3	593.7	633.6	720.2	760.0	804.8
QPB-1	11.7	21.4	38.9	54.4	70.9	95.2	113.7	113.7	125.3	146.7	176.8	207.0	210.8	130.2	136.0	157.4	163.2	177.8
QPB-2	12.6	24.3	41.8	59.2	76.7	99.1	117.5	117.5	129.2	151.5	179.7	201.0	228.2	252.5	258.4	272.9	279.7	289.5
QPB-3	13.6	24.2	42.7	59.2	76.6	99.9	118.3	118.3	130.0	152.3	181.4	205.7	231.9	267.8	275.5	286.2	289.1	294.0
QPB-4	N/A	N/A	N/A	N/A	N/A	N/A	N/A	N/A	N/A	N/A	N/A	N/A	N/A	N/A	N/A	N/A	N/A	N/A
QPB-5	10.7	17.5	29.1	38.8	49.5	62.1	73.7	73.7	80.5	94.1	110.6	120.3	129.0	141.6	143.5	195.0	215.3	225.0
QPB-6	7.8	12.6	19.4	25.2	31.0	38.8	45.6	45.6	49.5	58.2	68.9	74.7	80.5	89.2	90.2	87.3	86.3	83.4
Displacement																		
TQP-0	0.0043	0.0108	0.0129	0.0194	0.0259	0.0323	0.0388	0.0388	0.0453	0.0517	0.0647	0.0733	0.0841	0.1918	0.2047	0.2522	0.2672	0.2996
tqp-1	0.0022	0.0065	0.0130	0.0195	0.0261	0.0347	0.0413	0.0413	0.0413	0.0521	0.0630	0.0695	0.0847	0.1911	0.2041	0.2476	0.2606	0.2888
tqp-2	0.0044	0.0099	0.0177	0.0243	0.0309	0.0409	0.0453	0.0453	0.0497	0.0608	0.0718	0.0818	0.0951	0.2023	0.2166	0.2587	0.2730	0.3029
tqp-3	0.0000	0.0000	0.0065	0.0129	0.0194	0.0344	0.0409	0.0409	0.0473	0.0538	0.0667	0.0796	0.0925	0.1935	0.2064	0.2516	0.2666	0.2924
tqp-4	0.0011	0.0054	0.0161	0.0226	0.0291	0.0409	0.0463	0.0463	0.0495	0.0614	0.0743	0.0840	0.0991	0.1970	0.2099	0.2519	0.2659	0.2961
TQP-5	0.0046	0.0046	0.0183	0.0229	0.0275	0.0413	0.0505	0.0505	0.0550	0.0642	0.0780	0.0872	0.1009	0.2064	0.2202	0.2661	0.2752	0.3073
Mid-span-0	0.0000	0.0043	0.0172	0.0279	0.0343	0.0408	0.0536	0.0536	0.0579	0.0665	0.0815	0.0966	0.1094	0.2790	0.3004	0.3691	0.3949	0.4421
mid-span-1	0.0111	0.0134	0.0268	0.0334	0.0401	0.0535	0.0602	0.0602	0.0691	0.0803	0.0959	0.1070	0.1293	0.3166	0.3367	0.4058	0.4303	0.4749
mid-span-2	0.0066	0.0144	0.0233	0.0321	0.0399	0.0520	0.0631	0.0631	0.0698	0.0841	0.1030	0.1174	0.1417	0.3211	0.3410	0.4119	0.4351	0.4805
mid-span-4	0.0056	0.0145	0.0256	0.0356	0.0456	0.0589	0.0701	0.0701	0.0756	0.0890	0.1056	0.1201	0.1435	0.3158	0.3370	0.4081	0.4326	0.4793
mid-span-5	0.0000	0.0065	0.0195	0.0260	0.0411	0.0541	0.0649	0.0649	0.0714	0.0822	0.1017	0.1147	0.1407	0.3052	0.3268	0.3961	0.4134	0.4610
bqp-1	0.0044	0.0088	0.0144	0.0210	0.0276	0.0365	0.0431	0.0420	0.0464	0.0542	0.0652	0.0741	0.0862	0.1735	0.1857	0.2189	0.2310	0.2520
BQP-2	0.0046	0.0046	0.0137	0.0182	0.0228	0.0319	0.0456	0.0411	0.0456	0.0547	0.0684	0.0776	0.0912	0.1779	0.1870	0.2235	0.2372	0.2555
BQP-3	0.0000	0.0092	0.0138	0.0183	0.0275	0.0413	0.0505	0.0505	0.0505	0.0642	0.0780	0.0826	0.1009	0.1881	0.1927	0.2294	0.2431	0.2661
BQP-4	0.0046	0.0046	0.0091	0.0182	0.0228	0.0319	0.0410	0.0410	0.0410	0.0546	0.0637	0.0774	0.0910	0.1684	0.1730	0.2094	0.2140	0.2413
BQP-5	0.0043	0.0065	0.0151	0.0281	0.0346	0.0411	0.0475	0.0475	0.0540	0.0605	0.0756	0.0821	0.0951	0.1772	0.1837	0.2183	0.2248	0.2464

Slab: XOREX-50

Test: Transverse Linear Load Across Top Quarter Point (Figure 5.3-J)

Strain Gage Readings are in $\mu\text{in}/\text{in}$.

Displacement Readings are in inches.

Strain Gage	Load in lbs.													
	0	1371.1	2027.9	2487.6	3103.4	3530.3	4064	4688	5221.6	5771.7	6330	6691.2	7101.8	7668.3
QPT-1	0	3.9	5.8	7.8	9.7	10.7	12.6	14.6	16.5	18.4	20.4	21.4	22.3	25.2
QPT-2	0	3.9	6.8	7.8	9.7	11.6	13.6	15.5	17.5	19.4	21.3	22.3	24.3	26.2
QPT-3	0	3.9	5.8	7.8	9.7	11.7	13.6	15.5	17.5	19.4	21.4	23.3	25.2	27.2
QPT-4	0	4.9	6.8	8.7	10.7	12.6	15.5	17.5	20.4	22.3	25.2	26.2	28.2	31.1
QPT-5	0	14.5	23.3	29.1	37.8	43.6	51.4	60.1	67.9	75.7	83.4	88.3	95.1	102.8
QPT-6	0	8.7	13.6	17.5	22.3	25.2	30.1	34.9	39.8	43.7	48.5	52.4	55.3	60.2
MS-1	0	7.8	10.7	13.6	17.5	19.4	23.3	26.2	30.1	33.0	36.9	38.9	41.8	44.7
MS-2	0	6.8	9.7	11.7	14.6	16.5	19.4	22.4	25.3	27.2	30.1	32.1	34.0	36.0
MS-3	0	-2.1	-3.2	-3.8	-4.7	-5.3	-6.2	-7.1	-8.0	-8.6	-9.4	-10.0	-10.6	-11.5
MS-4	0	6.8	9.7	12.6	15.5	18.5	20.4	24.3	27.2	30.1	33.0	35.0	36.9	39.8
MS-5	N/A	N/A	N/A	N/A	N/A	N/A	N/A	N/A	N/A	N/A	N/A	N/A	N/A	N/A
MS-6	0	6.8	10.7	12.6	16.5	18.5	21.4	25.2	28.2	31.1	35.0	36.9	38.8	42.7
QPB-1	0	10.7	16.5	21.4	28.2	32.1	37.9	44.7	50.5	56.3	63.1	67.0	71.9	78.7
QPB-2	0	17.5	27.2	35.0	44.7	52.4	61.2	71.9	80.6	90.3	99.1	105.9	112.7	122.4
QPB-3	0	17.5	28.1	35.9	45.6	53.4	63.1	74.7	84.4	93.1	102.8	109.6	116.4	127.1
QPB-4	N/A	N/A	N/A	N/A	N/A	N/A	N/A	N/A	N/A	N/A	N/A	N/A	N/A	N/A
QPB-5	0	4.8	7.8	9.7	11.6	13.6	16.5	18.4	21.3	23.3	26.2	28.1	30.1	32.0
QPB-6	0	3.9	5.8	6.8	8.7	10.7	11.6	13.6	15.5	17.5	19.4	20.4	22.3	24.2
Displacement														
TQP-0	0.0000	0.0022	0.0086	0.0086	0.0086	0.0151	0.0151	0.0151	0.0151	0.0237	0.0237	0.0216	0.0237	0.0302
tqp-1	0.0022	0.0022	0.0022	0.0022	0.0109	0.0109	0.0109	0.0152	0.0174	0.0174	0.0174	0.0239	0.0261	0.0239
tqp-2	0.0011	0.0055	0.0077	0.0088	0.0111	0.0144	0.0166	0.0210	0.0232	0.0265	0.0298	0.0309	0.0332	0.0365
tqp-3	0.0022	0.0022	0.0022	0.0000	0.0065	0.0043	0.0065	0.0129	0.0108	0.0194	0.0172	0.0172	0.0237	0.0237
tqp-4	0.0011	0.0000	0.0032	0.0043	0.0075	0.0097	0.0118	0.0140	0.0172	0.0194	0.0215	0.0226	0.0258	0.0301
TQP-5	0.0000	0.0046	0.0092	0.0092	0.0138	0.0138	0.0229	0.0229	0.0229	0.0275	0.0275	0.0367	0.0367	0.0367
Mid-span-0	0.0021	0.0021	0.0021	0.0021	0.0021	0.0064	0.0043	0.0043	0.0107	0.0107	0.0107	0.0107	0.0172	0.0193
mid-span-1	0.0134	0.0134	0.0201	0.0201	0.0201	0.0268	0.0290	0.0290	0.0357	0.0357	0.0357	0.0379	0.0424	0.0446
mid-span-2	0.0000	0.0033	0.0055	0.0078	0.0111	0.0133	0.0155	0.0199	0.0221	0.0244	0.0277	0.0277	0.0299	0.0332
mid-span-4	0.0011	0.0044	0.0067	0.0089	0.0111	0.0145	0.0167	0.0211	0.0234	0.0256	0.0278	0.0289	0.0311	0.0356
mid-span-5	0.0022	0.0065	0.0065	0.0130	0.0130	0.0130	0.0195	0.0195	0.0260	0.0260	0.0260	0.0325	0.0325	0.0325
bqp-1	0.0011	0.0011	0.0022	0.0022	0.0033	0.0044	0.0066	0.0088	0.0099	0.0111	0.0133	0.0144	0.0166	0.0177
BQP-2	0.0000	0.0000	0.0000	0.0000	0.0000	0.0046	0.0091	0.0091	0.0091	0.0137	0.0137	0.0137	0.0137	0.0228
BQP-3	0.0046	0.0046	0.0046	0.0046	0.0092	0.0092	0.0092	0.0183	0.0183	0.0183	0.0183	0.0229	0.0229	0.0275
BQP-4	0.0000	0.0000	0.0046	0.0000	0.0046	0.0046	0.0046	0.0091	0.0091	0.0091	0.0137	0.0137	0.0182	0.0182
BQP-5	0.0000	0.0065	0.0065	0.0043	0.0130	0.0130	0.0130	0.0195	0.0195	0.0173	0.0195	0.0259	0.0259	0.0259

Strain Gage	Load in lbs.																
	8136.2	8637.1	9146.1	9499.1	10000	10492	10853	10919	11190	11330	11839	12512	13201	13169	13719	14376	15049
QPT-1	26.2	28.2	30.1	31.1	33.0	34.0	35.9	35.9	36.9	37.9	38.8	41.7	44.7	43.7	45.6	48.5	51.4
QPT-2	28.1	30.1	32.0	33.0	34.9	36.9	37.8	38.8	39.8	39.8	41.7	44.6	46.6	47.6	48.5	51.4	52.4
QPT-3	29.1	31.1	33.0	35.0	36.9	38.8	40.8	40.8	41.8	42.7	44.7	47.6	50.5	49.5	52.4	54.4	56.3
QPT-4	33.0	34.9	37.9	38.8	41.7	43.7	44.7	45.6	46.6	47.6	49.5	52.4	55.3	55.3	58.3	60.2	62.1
QPT-5	109.6	116.4	124.2	129.0	136.8	143.6	149.4	150.3	155.2	157.1	163.9	174.6	186.2	186.2	197.9	211.5	183.3
QPT-6	64.1	68.9	73.8	76.7	81.5	85.4	89.3	89.3	92.2	93.2	98.1	104.9	111.6	111.6	119.4	129.1	182.5
MS-1	47.6	51.5	54.4	56.3	59.3	63.1	65.1	66.1	68.0	69.0	71.9	75.8	80.6	80.6	83.5	88.4	95.2
MS-2	38.9	40.8	42.8	44.7	46.7	49.6	51.5	51.5	52.5	53.5	56.4	59.3	62.2	62.2	64.1	66.1	67.1
MS-3	-12.1	-12.7	-13.6	-13.9	-14.7	-15.3	-15.9	-15.9	-16.2	-16.5	-17.4	-18.3	-19.2	-19.2	-19.5	-20.1	-19.8
MS-4	42.8	45.7	47.6	50.5	52.5	55.4	57.3	58.3	59.3	60.2	63.2	67.0	70.0	70.0	72.9	75.8	75.8
MS-5	N/A	N/A	N/A	N/A	N/A	N/A	N/A	N/A	N/A	N/A	N/A	N/A	N/A	N/A	N/A	N/A	N/A
MS-6	44.7	48.6	51.5	53.4	56.3	59.2	61.2	62.2	64.1	65.1	68.0	71.9	75.7	75.7	79.6	83.5	89.3
QPB-1	84.5	90.3	96.2	101.0	106.9	112.7	117.5	118.5	123.4	125.3	131.1	142.8	163.2	164.2	182.6	195.3	242.9
QPB-2	130.1	138.9	147.6	153.5	162.2	170.9	177.7	179.7	184.5	187.4	196.2	207.8	221.5	221.5	220.5	230.2	217.6
QPB-3	134.8	143.6	152.3	159.1	167.8	175.6	183.4	184.3	189.2	192.1	200.8	213.4	226.1	223.1	221.2	228.0	238.7
QPB-4	N/A	N/A	N/A	N/A	N/A	N/A	N/A	N/A	N/A	N/A	N/A	N/A	N/A	N/A	N/A	N/A	N/A
QPB-5	33.9	36.9	38.8	40.7	42.7	44.6	46.6	47.5	48.5	49.5	51.4	54.3	57.2	57.2	60.1	62.1	64.0
QPB-6	25.2	27.2	29.1	30.1	32.0	33.9	34.9	34.9	35.9	36.9	38.8	40.7	42.7	42.7	44.6	47.5	49.5
Displacement																	
TQP-0	0.0280	0.0302	0.0302	0.0366	0.0366	0.0366	0.0366	0.0366	0.0431	0.0431	0.0431	0.0431	0.0517	0.0517	0.0496	0.0496	0.0582
tqp-1	0.0282	0.0304	0.0326	0.0326	0.0391	0.0391	0.0391	0.0391	0.0413	0.0413	0.0478	0.0478	0.0499	0.0499	0.0543	0.0543	0.0608
tqp-2	0.0387	0.0409	0.0431	0.0442	0.0475	0.0508	0.0520	0.0531	0.0553	0.0553	0.0575	0.0619	0.0641	0.0641	0.0652	0.0685	0.0829
tqp-3	0.0237	0.0301	0.0301	0.0301	0.0387	0.0366	0.0387	0.0430	0.0452	0.0430	0.0430	0.0495	0.0495	0.0495	0.0581	0.0559	0.0710
tqp-4	0.0334	0.0345	0.0355	0.0377	0.0398	0.0420	0.0441	0.0441	0.0463	0.0463	0.0474	0.0517	0.0571	0.0571	0.0581	0.0603	0.0711
TQP-5	0.0413	0.0413	0.0413	0.0505	0.0505	0.0459	0.0550	0.0550	0.0550	0.0550	0.0550	0.0642	0.0596	0.0642	0.0688	0.0688	0.0734
Mid-span-0	0.0172	0.0258	0.0236	0.0258	0.0236	0.0300	0.0322	0.0322	0.0322	0.0300	0.0300	0.0365	0.0386	0.0386	0.0429	0.0451	0.0515
mid-span-1	0.0424	0.0491	0.0491	0.0513	0.0580	0.0602	0.0580	0.0580	0.0647	0.0647	0.0647	0.0647	0.0736	0.0736	0.0713	0.0780	0.0780
mid-span-2	0.0354	0.0376	0.0410	0.0432	0.0454	0.0465	0.0487	0.0498	0.0520	0.0520	0.0531	0.0565	0.0598	0.0598	0.0620	0.0653	0.0731
mid-span-4	0.0400	0.0411	0.0423	0.0434	0.0467	0.0500	0.0523	0.0523	0.0556	0.0556	0.0567	0.0589	0.0634	0.0634	0.0656	0.0701	0.0767
mid-span-5	0.0390	0.0390	0.0390	0.0476	0.0476	0.0476	0.0519	0.0541	0.0519	0.0541	0.0519	0.0584	0.0606	0.0606	0.0671	0.0671	0.0736
bqp-1	0.0188	0.0210	0.0221	0.0232	0.0243	0.0265	0.0276	0.0276	0.0287	0.0287	0.0298	0.0321	0.0343	0.0343	0.0365	0.0387	0.0420
BQP-2	0.0228	0.0228	0.0182	0.0228	0.0274	0.0274	0.0274	0.0274	0.0319	0.0365	0.0365	0.0365	0.0365	0.0319	0.0411	0.0411	0.0456
BQP-3	0.0229	0.0321	0.0321	0.0321	0.0321	0.0367	0.0367	0.0413	0.0367	0.0413	0.0367	0.0459	0.0459	0.0459	0.0459	0.0505	0.0505
BQP-4	0.0228	0.0228	0.0228	0.0228	0.0273	0.0273	0.0273	0.0273	0.0273	0.0273	0.0364	0.0364	0.0364	0.0364	0.0410	0.0410	0.0410
BQP-5	0.0259	0.0324	0.0324	0.0324	0.0324	0.0389	0.0389	0.0389	0.0389	0.0389	0.0389	0.0454	0.0475	0.0454	0.0454	0.0540	0.0540

Slab: XOREX-50

Test: Transverse Linear Load Across Bottom Quarter Point (Figure 5.3-K)

Strain Gage Readings are in $\mu\text{in/in}$.

Displacement Readings are in inches.

Strain Gage	Load in lbs.													
	0	500.82	1428.5	2036.1	2504.1	3029.5	3620.6	4285.7	4704.4	5221.6	5730.7	6223.3	6642	7233.1
QPT-1	0	3.9	11.6	16.5	20.4	24.3	30.1	34.9	38.8	43.7	48.5	52.4	56.3	61.2
QPT-2	0	5.8	18.4	27.2	34.9	42.7	51.4	62.1	67.9	75.7	83.5	91.2	98.0	105.8
QPT-3	0	7.8	22.3	32.0	39.8	48.6	59.2	70.9	77.7	87.4	97.1	105.9	113.6	123.3
QPT-4	0	5.8	18.4	27.2	34.0	41.7	50.5	60.2	67.0	74.8	82.5	90.3	97.1	105.8
QPT-5	0	1.9	4.8	6.8	7.8	9.7	11.6	14.5	15.5	17.5	19.4	21.3	23.3	25.2
QPT-6	0	1.9	4.9	6.8	7.8	9.7	11.6	13.6	15.5	16.5	18.4	20.4	22.3	23.3
MS-1	0	2.9	8.7	11.7	14.6	17.5	21.4	25.3	28.2	31.1	34.0	37.9	40.8	43.7
MS-2	0	1.9	6.8	9.7	11.7	14.6	17.5	20.4	22.4	24.3	27.2	29.2	31.1	34.0
MS-3	0	-0.9	-2.4	-3.2	-3.8	-4.4	-5.3	-6.5	-7.1	-7.7	-8.6	-9.1	-9.7	-10.6
MS-4	0	1.9	6.8	10.7	12.6	15.5	18.5	22.3	24.3	27.2	30.1	32.1	35.0	37.9
MS-5	N/A	N/A	N/A	N/A	N/A	N/A	N/A	N/A	N/A	N/A	N/A	N/A	N/A	N/A
MS-6	0	9.7	12.6	15.5	14.6	18.4	21.4	23.3	25.2	27.2	30.1	33.0	39.8	35.0
QPB-1	0	1.9	4.9	6.8	8.7	10.7	12.6	14.6	16.5	18.5	21.4	22.3	24.3	27.2
QPB-2	0	1.9	4.9	6.8	7.8	9.7	11.7	14.6	16.5	18.5	20.4	22.3	24.3	26.2
QPB-3	0	1.0	3.9	5.8	7.8	8.7	11.6	13.6	15.5	17.5	19.4	21.3	23.3	26.2
QPB-4	N/A	N/A	N/A	N/A	N/A	N/A	N/A	N/A	N/A	N/A	N/A	N/A	N/A	N/A
QPB-5	0	5.8	17.5	25.2	32.0	38.8	47.5	57.2	63.0	69.8	77.6	84.4	91.2	98.9
QPB-6	0	2.9	8.7	12.6	15.5	19.4	23.3	28.1	30.1	33.9	37.8	40.7	43.6	47.5
Displacement														
TQP-0	0	0.0022	0.0000	0.0000	0.0065	0.0065	0.0065	0.0065	0.0129	0.0129	0.0129	0.0129	0.0108	0.0194
tqp-1	0	0.0022	0.0043	0.0043	0.0087	0.0087	0.0087	0.0087	0.0130	0.0152	0.0152	0.0152	0.0152	0.0217
tqp-2	0	0.0000	0.0022	0.0033	0.0055	0.0066	0.0088	0.0099	0.0111	0.0111	0.0133	0.0155	0.0166	0.0188
tqp-3	0	0.0022	0.0022	0.0000	0.0000	0.0000	0.0022	0.0022	0.0022	0.0065	0.0086	0.0086	0.0086	0.0108
tqp-4	0	0.0011	0.0000	0.0011	0.0022	0.0054	0.0065	0.0086	0.0097	0.0108	0.0129	0.0140	0.0140	0.0161
TQP-5	0	0.0000	0.0000	0.0092	0.0046	0.0046	0.0092	0.0138	0.0138	0.0138	0.0183	0.0183	0.0183	0.0183
Mid-span-0	0	0.0021	0.0000	0.0000	0.0021	0.0064	0.0064	0.0043	0.0129	0.0107	0.0129	0.0172	0.0193	0.0193
mid-span-1	0	0.0022	0.0089	0.0089	0.0156	0.0156	0.0156	0.0223	0.0223	0.0223	0.0290	0.0290	0.0290	0.0357
mid-span-2	0	0.0044	0.0044	0.0066	0.0089	0.0111	0.0144	0.0166	0.0188	0.0221	0.0244	0.0266	0.0277	0.0299
mid-span-4	0	0.0000	0.0044	0.0067	0.0078	0.0111	0.0133	0.0167	0.0189	0.0211	0.0234	0.0256	0.0267	0.0289
mid-span-5	0	0.0022	0.0022	0.0043	0.0043	0.0043	0.0043	0.0108	0.0108	0.0108	0.0173	0.0195	0.0195	0.0238
bqp-1	0	0.0011	0.0033	0.0055	0.0066	0.0088	0.0122	0.0144	0.0166	0.0188	0.0210	0.0232	0.0254	0.0276
BQP-2	0	0.0000	0.0000	0.0000	0.0000	0.0046	0.0046	0.0137	0.0137	0.0182	0.0182	0.0182	0.0228	0.0274
BQP-3	0	0.0000	0.0000	0.0000	0.0046	0.0092	0.0138	0.0138	0.0138	0.0229	0.0229	0.0275	0.0275	0.0275
BQP-4	0	0.0000	0.0000	0.0000	0.0000	0.0000	0.0046	0.0046	0.0137	0.0137	0.0137	0.0182	0.0182	0.0182
BQP-5	0	0.0065	0.0086	0.0086	0.0130	0.0151	0.0195	0.0195	0.0195	0.0259	0.0281	0.0281	0.0281	0.0346

Load in lbs.											
Strain Gage	7873.5	8555	9080.4	9638.7	10139	10640	11272	11707	12101	12676	13218
QPT-1	68.0	73.8	77.7	83.5	88.3	92.2	98.0	101.9	106.8	112.6	117.5
QPT-2	116.5	126.2	133.9	143.6	151.4	158.2	167.9	174.7	180.5	190.2	199.9
QPT-3	136.0	148.6	157.3	169.0	177.7	186.5	198.1	206.9	214.7	226.3	238.0
QPT-4	115.5	126.2	134.0	143.7	151.5	159.2	168.9	176.7	183.5	194.2	204.9
QPT-5	28.1	31.0	33.0	35.9	37.8	40.7	43.6	45.6	47.5	50.4	52.4
QPT-6	26.2	29.1	30.1	33.0	34.9	36.9	38.8	39.8	41.7	43.7	46.6
MS-1	47.6	52.5	55.4	59.3	62.2	65.1	69.0	71.9	74.8	78.7	81.6
MS-2	36.0	39.8	41.8	44.7	47.6	49.6	52.5	54.4	56.4	59.3	61.2
MS-3	-11.5	-12.4	-13.0	-13.9	-14.4	-15.0	-15.9	-16.5	-17.1	-18.0	-18.6
MS-4	40.8	44.7	47.6	50.5	52.5	55.4	59.3	61.2	63.2	67.0	70.0
MS-5	N/A	N/A	N/A	N/A	N/A	N/A	N/A	N/A	N/A	N/A	N/A
MS-6	42.7	46.6	45.6	48.6	63.1	69.9	59.2	59.2	64.1	61.2	70.9
QPB-1	29.1	33.0	35.0	36.9	39.8	41.8	43.7	46.6	47.6	50.5	53.4
QPB-2	29.1	32.0	34.0	35.9	37.9	40.8	42.7	44.7	46.6	49.5	52.4
QPB-3	28.1	31.0	33.0	35.9	37.8	39.8	42.7	44.6	46.6	48.5	50.4
QPB-4	N/A	N/A	N/A	N/A	N/A	N/A	N/A	N/A	N/A	N/A	N/A
QPB-5	107.7	118.3	126.1	133.8	141.6	148.4	157.1	164.9	170.7	180.4	190.1
QPB-6	52.4	57.2	60.1	65.0	68.9	71.8	76.6	79.5	82.4	87.3	92.1
Displacement											
TQP-0	0.0194	0.0194	0.0194	0.0259	0.0259	0.0259	0.0259	0.0323	0.0323	0.0323	0.0323
tqp-1	0.0217	0.0217	0.0217	0.0282	0.0304	0.0282	0.0282	0.0347	0.0347	0.0347	0.0369
tqp-2	0.0210	0.0232	0.0254	0.0276	0.0287	0.0309	0.0321	0.0343	0.0354	0.0376	0.0387
tqp-3	0.0151	0.0151	0.0151	0.0215	0.0215	0.0215	0.0215	0.0280	0.0280	0.0280	0.0280
tqp-4	0.0183	0.0205	0.0215	0.0226	0.0248	0.0258	0.0291	0.0323	0.0334	0.0355	0.0366
TQP-5	0.0275	0.0275	0.0229	0.0321	0.0321	0.0321	0.0321	0.0321	0.0367	0.0367	0.0367
Mid-span-0	0.0236	0.0258	0.0258	0.0322	0.0343	0.0322	0.0386	0.0408	0.0408	0.0408	0.0472
mid-span-1	0.0357	0.0424	0.0424	0.0424	0.0513	0.0491	0.0513	0.0580	0.0557	0.0557	0.0624
mid-span-2	0.0332	0.0365	0.0388	0.0421	0.0443	0.0465	0.0498	0.0509	0.0531	0.0565	0.0576
mid-span-4	0.0322	0.0356	0.0411	0.0423	0.0434	0.0445	0.0489	0.0512	0.0523	0.0556	0.0567
mid-span-5	0.0260	0.0281	0.0303	0.0325	0.0346	0.0390	0.0390	0.0411	0.0455	0.0455	0.0476
bqp-1	0.0298	0.0332	0.0354	0.0376	0.0398	0.0420	0.0453	0.0475	0.0486	0.0508	0.0531
BQP-2	0.0319	0.0319	0.0365	0.0411	0.0411	0.0456	0.0456	0.0456	0.0502	0.0502	0.0593
BQP-3	0.0367	0.0321	0.0413	0.0413	0.0413	0.0505	0.0505	0.0550	0.0550	0.0550	0.0642
BQP-4	0.0273	0.0273	0.0273	0.0319	0.0319	0.0364	0.0364	0.0364	0.0364	0.0455	0.0455
BQP-5	0.0346	0.0411	0.0411	0.0411	0.0475	0.0497	0.0475	0.0540	0.0540	0.0562	0.0540

Test Designation: Microfiber-MD- Concentrated Loads
Cast Date: 07/17/2001
Test Date: 08/17/2001

Materials and Dimensions

General:

Width: 9 ft (3 panels)
Span length: 10 ft.
Type of Reinforcement: 25 lb/yd³ -1 ½” Xorex Fiber

Deck:

Deck type: 2VLI-20
Design Thickness: 0.0358 in
Height: 2 in
Area: 0.519 in²/ft
Yield Stress: 50 ksi
Ultimate Strength: 60 ksi

Concrete:

Test Strength: 3800 psi
Total Depth: 5.5 in

Results

Maximum Applied Load: 13.27 kips
Mid-Span Deflection at Maximum Load: 0.110 in
Quarter Point-1 Deflection at Maximum Load: 0.075 in
Quarter Point-2 Deflection at Maximum Load: 0.073 in
End Slip at Maximum Load: 0.0007 in

Strains Due to Fresh Concrete (µε)

Strain Gage	1	2	3	4	5	6
Quarter Point-1	512.22	510.99	563.87	559.38	509.69	502.59
Mid-Span	683.78	707.37	793.05	797.25	730.77	756.11
Quarter Point-2	493.89	624.12	553.43	542.31	464.21	541.34

Table F-4 Non-Distributed Load Tests Data on Microfiber-MD Slab
Slab: Microfiber-MD

Test: Concentrated Load at Bottom Quarter Point (Figure 5.3-A)

Strain Gage Readings are in $\mu\text{in/in}$

Displacement Readings are in inches.

Strain Gage	Load in lbs.														
	0	558.29	1091.9	1551.7	2068.9	2709.3	3062.3	3497.5	4088.6	4532	5131.3	6133	6625.6	7142.8	7701.1
QPT-1	0	1.9	3.9	4.9	6.8	8.7	9.7	11.6	13.6	14.6	16.5	20.4	22.3	24.3	26.2
QPT-2	0	1.9	3.9	4.9	7.8	9.7	11.6	12.6	14.6	16.5	19.4	23.3	25.2	27.2	29.1
QPT-3	0	1.9	3.9	5.8	7.8	10.7	12.6	14.6	16.5	18.5	21.4	26.2	28.2	30.1	33.0
QPT-4	0	1.9	2.9	4.9	6.8	8.7	10.7	11.7	13.6	15.6	17.5	21.4	22.4	24.3	26.2
QPT-5	0	2.9	3.9	5.8	7.8	11.6	13.6	14.5	16.5	18.4	20.4	24.2	27.1	29.1	31.0
QPT-6	0	1.9	3.9	4.9	6.8	8.7	10.7	11.7	13.6	15.5	17.5	20.4	22.3	24.3	26.2
MS-1	0	2.9	5.8	7.8	10.7	15.5	17.5	20.4	23.3	26.2	30.1	36.9	39.8	43.7	47.6
MS-2	0	2.9	6.8	9.7	12.6	17.5	19.4	22.3	26.2	29.1	33.0	39.8	42.7	46.6	49.5
MS-3	0	-1.2	-2.1	-3.0	-4.1	-5.6	-6.2	-7.1	-8.3	-9.2	-10.3	-12.7	-13.6	-14.8	-16.0
MS-4	0	-1.0	2.9	5.8	30.1	-1.9	-24.3	-26.2	-22.4	-18.5	-14.6	-8.7	-11.7	-7.8	-3.9
MS-5	0	3.9	6.8	10.7	13.6	19.4	22.3	25.2	29.1	33.0	36.9	44.6	48.5	52.4	57.2
MS-6	0	3.9	6.8	9.7	12.6	19.4	20.4	23.3	26.2	29.2	33.0	39.8	41.8	45.7	49.6
QPB-1	0	3.9	6.8	9.7	12.6	17.5	19.4	22.3	26.2	29.1	33.0	39.8	43.7	47.6	51.5
QPB-2	0	5.8	12.6	18.4	26.2	35.9	40.7	47.5	55.3	62.1	70.8	87.3	96.0	106.7	117.4
QPB-3	0	7.8	14.5	20.4	28.1	38.8	43.7	50.4	59.2	66.0	75.7	91.2	98.9	103.8	110.6
QPB-4	0	6.8	13.6	19.4	26.2	35.0	40.8	46.6	54.4	61.2	68.9	83.5	90.3	97.1	103.9
QPB-5	0	9.7	15.5	20.4	28.2	50.5	52.5	57.3	64.1	69.0	76.8	89.4	99.1	105.9	112.7
QPB-6	0	2.9	6.8	9.7	12.6	17.5	19.4	22.3	25.2	28.2	32.0	38.8	42.7	46.6	50.5
Displacement															
TQP-0	0	0.0000	0.0022	0.0022	0.0022	0.0022	0.0022	0.0086	0.0086	0.0086	0.0086	0.0151	0.0151	0.0151	0.0151
tqp-1	0	0.0000	0.0000	0.0022	0.0022	0.0022	0.0022	0.0022	0.0022	0.0087	0.0087	0.0087	0.0130	0.0174	0.0174
tqp-2	0	0.0000	0.0000	0.0022	0.0033	0.0044	0.0055	0.0066	0.0077	0.0099	0.0122	0.0166	0.0188	0.0199	0.0221
tqp-3	0	0.0000	0.0000	0.0000	0.0000	0.0000	0.0000	0.0000	0.0000	0.0022	0.0000	0.0065	0.0065	0.0086	0.0151
tqp-4	0	0.0000	0.0000	0.0000	0.0000	0.0022	0.0032	0.0043	0.0065	0.0075	0.0097	0.0129	0.0151	0.0161	0.0194
TQP-5	0	0.0000	0.0000	0.0000	0.0000	0.0046	0.0046	0.0092	0.0046	0.0138	0.0138	0.0138	0.0183	0.0183	0.0229
Mid-span-0	0	0.0021	0.0021	0.0021	0.0000	0.0021	0.0064	0.0064	0.0064	0.0064	0.0129	0.0129	0.0193	0.0193	0.0193
mid-span-1	0	0.0067	0.0067	0.0067	0.0134	0.0111	0.0111	0.0201	0.0201	0.0201	0.0201	0.0268	0.0268	0.0334	0.0334
mid-span-2	0	0.0011	0.0011	0.0022	0.0055	0.0078	0.0078	0.0100	0.0133	0.0144	0.0188	0.0233	0.0255	0.0277	0.0299
mid-span-4	0	0.0000	0.0011	0.0022	0.0056	0.0089	0.0111	0.0133	0.0156	0.0167	0.0200	0.0245	0.0267	0.0289	0.0322
mid-span-5	0	0.0022	0.0022	0.0022	0.0043	0.0108	0.0022	0.0043	0.0108	0.0108	0.0130	0.0195	0.0173	0.0238	0.0260
bqp-1	0	0.0000	0.0011	0.0011	0.0033	0.0055	0.0066	0.0077	0.0111	0.0133	0.0155	0.0199	0.0210	0.0232	0.0254
BQP-2	0	0.0000	0.0000	0.0000	0.0000	0.0091	0.0046	0.0046	0.0046	0.0137	0.0137	0.0182	0.0228	0.0274	0.0274
BQP-3	0	0.0000	0.0000	0.0000	0.0092	0.0092	0.0046	0.0138	0.0138	0.0138	0.0183	0.0183	0.0275	0.0275	0.0275
BQP-4	0	0.0000	0.0000	0.0000	0.0000	0.0046	0.0046	0.0091	0.0091	0.0137	0.0137	0.0182	0.0182	0.0182	0.0273
BQP-5	0	0.0000	0.0065	0.0086	0.0130	0.0151	0.0130	0.0151	0.0130	0.0216	0.0216	0.0281	0.0281	0.0281	0.0346

Concentrated Load at Bottom Quarter Point Continued.

Strain Gage	8045.9	8546.7	9211.8	9564.8	10295	10599	11157	11650	12003	12471	13119	13686	14014	14548	15041
QPT-1	28.2	29.1	32.0	33.0	35.9	37.9	39.8	41.7	43.7	44.7	47.6	49.5	51.5	53.4	55.3
QPT-2	31.0	33.0	35.9	37.8	40.8	41.7	43.7	45.6	46.6	49.5	51.4	53.4	54.3	56.3	57.2
QPT-3	35.0	36.9	40.8	42.7	45.7	47.6	50.5	52.5	54.4	56.3	59.3	62.2	64.1	67.0	69.0
QPT-4	28.2	29.2	31.1	33.0	36.0	36.0	37.9	39.9	40.8	41.8	42.8	44.7	45.7	46.7	47.6
QPT-5	33.0	34.9	37.8	39.8	42.7	43.6	45.6	47.5	48.5	50.4	53.3	54.3	56.2	58.2	60.1
QPT-6	28.2	30.1	33.0	34.0	36.9	37.9	39.8	41.8	43.7	45.6	47.6	50.5	51.5	54.4	56.3
MS-1	50.5	53.4	58.2	61.2	67.0	68.9	73.8	78.6	81.5	84.5	90.3	96.1	99.0	103.9	109.7
MS-2	52.4	55.4	60.2	63.1	67.0	69.0	72.8	75.8	77.7	81.6	85.5	89.4	92.3	96.2	99.1
MS-3	-16.5	-17.4	-18.6	-19.5	-20.7	-21.0	-21.9	-22.7	-23.3	-24.2	-24.8	-25.7	-26.3	-27.5	-28.1
MS-4	-1.0	2.9	4.9	6.8	8.7	11.7	15.6	19.4	21.4	24.3	34.0	36.9	41.8	50.6	57.4
MS-5	60.2	64.0	68.9	72.8	77.6	79.6	84.4	88.3	91.2	96.1	101.9	106.7	110.6	115.5	121.3
MS-6	52.5	55.4	61.2	66.1	73.9	77.8	83.6	89.4	93.3	99.1	107.9	115.7	123.4	136.1	148.7
QPB-1	54.4	59.2	65.1	68.0	75.7	78.7	85.5	90.3	95.2	102.0	116.5	126.2	134.0	145.7	169.9
QPB-2	124.2	136.8	153.3	163.9	183.3	193.0	211.5	230.9	245.4	263.9	298.8	324.0	341.5	375.5	431.8
QPB-3	129.0	153.3	193.1	208.6	237.7	245.5	260.0	284.3	292.0	308.5	324.1	337.7	347.4	367.8	379.4
QPB-4	108.7	116.5	132.1	141.8	263.2	285.5	330.2	330.2	335.1	350.6	385.6	404.0	417.6	425.4	435.1
QPB-5	117.6	125.4	137.0	143.9	157.5	164.3	177.9	192.5	203.2	216.8	238.2	253.7	265.4	282.9	302.3
QPB-6	53.4	58.2	64.1	67.0	73.8	77.7	84.5	97.1	103.9	114.6	143.7	163.1	173.8	189.3	211.7
Displacement															
TQP-0	0.0216	0.0216	0.0216	0.0216	0.0280	0.0280	0.0302	0.0302	0.0302	0.0345	0.0345	0.0345	0.0431	0.0431	0.0431
tqp-1	0.0174	0.0174	0.0239	0.0239	0.0239	0.0239	0.0282	0.0304	0.0304	0.0304	0.0369	0.0369	0.0369	0.0369	0.0434
tqp-2	0.0232	0.0243	0.0265	0.0276	0.0298	0.0309	0.0332	0.0354	0.0365	0.0376	0.0409	0.0431	0.0442	0.0464	0.0508
tqp-3	0.0129	0.0129	0.0129	0.0194	0.0215	0.0215	0.0215	0.0258	0.0258	0.0258	0.0344	0.0344	0.0323	0.0409	0.0409
tqp-4	0.0205	0.0226	0.0258	0.0269	0.0301	0.0301	0.0312	0.0323	0.0334	0.0345	0.0377	0.0409	0.0420	0.0452	0.0495
TQP-5	0.0229	0.0275	0.0275	0.0275	0.0321	0.0321	0.0321	0.0413	0.0413	0.0413	0.0413	0.0459	0.0459	0.0550	0.0550
Mid-span-0	0.0193	0.0258	0.0258	0.0258	0.0343	0.0343	0.0343	0.0408	0.0386	0.0408	0.0472	0.0472	0.0494	0.0536	0.0579
mid-span-1	0.0334	0.0401	0.0401	0.0401	0.0491	0.0468	0.0468	0.0535	0.0557	0.0602	0.0624	0.0691	0.0691	0.0691	0.0736
mid-span-2	0.0310	0.0343	0.0388	0.0399	0.0432	0.0454	0.0476	0.0509	0.0531	0.0565	0.0620	0.0642	0.0675	0.0720	0.0764
mid-span-4	0.0334	0.0356	0.0389	0.0400	0.0445	0.0456	0.0489	0.0523	0.0545	0.0567	0.0612	0.0645	0.0667	0.0701	0.0745
mid-span-5	0.0260	0.0303	0.0325	0.0368	0.0390	0.0390	0.0455	0.0455	0.0455	0.0519	0.0519	0.0606	0.0584	0.0671	0.0649
bqp-1	0.0276	0.0298	0.0332	0.0343	0.0376	0.0387	0.0409	0.0431	0.0453	0.0475	0.0497	0.0542	0.0575	0.0608	0.0652
BQP-2	0.0274	0.0319	0.0365	0.0319	0.0411	0.0411	0.0456	0.0456	0.0456	0.0547	0.0593	0.0593	0.0639	0.0639	0.0730
BQP-3	0.0321	0.0367	0.0367	0.0413	0.0413	0.0459	0.0459	0.0459	0.0550	0.0550	0.0642	0.0688	0.0688	0.0734	0.0780
BQP-4	0.0273	0.0273	0.0364	0.0364	0.0410	0.0410	0.0364	0.0455	0.0455	0.0501	0.0546	0.0546	0.0592	0.0592	0.0683
BQP-5	0.0346	0.0346	0.0432	0.0411	0.0411	0.0411	0.0475	0.0497	0.0497	0.0540	0.0540	0.0605	0.0627	0.0692	0.0692

Slab: Microfiber-MD

Test: Concentrated Load at Mid-Span (Figure 5.3-B)

Strain Gage Readings are in $\mu\text{in}/\text{in}$.

Displacement Readings are in inches.

Strain Gage	Load in lbs.															
	0	665.02	1420.3	1527	2044.3	2569.7	2980.2	3637.1	4072.2	4490.9	5147.7	5681.4	5993.4	6494.2	7044.3	7791.4
QPT-1	0	2.9	7.8	8.7	12.6	15.5	17.5	21.4	24.3	27.2	31.1	34.9	36.9	39.8	43.7	48.5
QPT-2	0	4.9	10.7	12.6	16.5	20.4	23.3	28.1	32.0	34.9	40.8	44.6	47.5	51.4	55.3	61.1
QPT-3	0	6.8	12.6	12.6	16.5	21.4	25.3	31.1	35.0	37.9	44.7	48.6	50.5	55.4	60.2	67.0
QPT-4	0	4.9	9.7	11.7	15.6	17.5	21.4	25.3	28.2	31.1	36.0	38.9	41.8	44.7	47.6	51.5
QPT-5	0	4.8	11.6	13.6	17.5	20.4	24.2	29.1	32.0	34.9	40.7	44.6	46.5	50.4	54.3	61.1
QPT-6	0	4.9	8.7	9.7	12.6	16.5	18.4	22.3	25.2	28.2	32.0	35.0	36.9	40.8	44.7	49.5
MS-1	0	5.8	12.6	13.6	18.4	22.3	26.2	32.0	35.9	39.8	45.6	50.5	53.4	59.2	64.1	72.8
MS-2	0	7.8	17.5	19.4	26.2	33.0	37.9	46.6	52.4	57.3	66.0	74.8	78.7	86.4	96.2	112.7
MS-3	0	-3.2	-7.4	-8.0	-10.6	-13.3	-15.4	-18.6	-21.0	-23.0	-26.9	-30.1	-32.2	-35.1	-42.2	-60.3
MS-4	0	15.6	30.1	24.3	36.0	45.7	57.4	71.9	93.3	92.4	140.0	179.9	182.8	179.9	194.5	203.2
MS-5	0	7.8	17.5	19.4	26.2	33.0	38.8	47.5	53.4	58.2	66.9	74.7	79.6	87.3	96.1	108.7
MS-6	0	6.8	13.6	13.6	19.4	25.3	29.2	36.0	41.8	45.7	53.5	59.3	63.2	70.0	76.8	87.5
QPB-1	0	3.9	8.7	9.7	12.6	15.5	19.4	23.3	27.2	29.1	35.0	38.8	41.8	45.6	50.5	56.3
QPB-2	0	4.8	11.6	12.6	18.4	23.3	28.1	35.9	40.7	45.6	54.3	62.1	66.9	73.7	81.5	93.1
QPB-3	0	4.9	10.7	11.6	16.5	21.3	25.2	32.0	36.9	41.7	49.5	55.3	59.2	66.0	72.8	81.5
QPB-4	0	4.9	10.7	12.6	16.5	22.3	26.2	34.0	39.8	44.7	52.4	59.2	63.1	69.9	77.7	86.4
QPB-5	0	2.9	7.8	7.8	12.6	16.5	20.4	27.2	31.1	35.0	41.8	48.6	49.6	54.4	61.2	69.0
QPB-6	0	3.9	9.7	10.7	14.6	18.4	22.3	28.2	32.0	35.9	41.7	46.6	49.5	55.3	61.2	68.9
Displacement																
TQP-0	0	0.0022	0.0000	0.0022	0.0043	0.0043	0.0043	0.0108	0.0108	0.0108	0.0172	0.0151	0.0151	0.0237	0.0237	0.0302
tqp-1	0	0.0022	0.0000	0.0022	0.0022	0.0043	0.0043	0.0043	0.0130	0.0109	0.0109	0.0195	0.0195	0.0195	0.0261	0.0261
tqp-2	0	0.0011	0.0044	0.0055	0.0077	0.0111	0.0133	0.0166	0.0188	0.0210	0.0243	0.0265	0.0276	0.0298	0.0332	0.0376
tqp-3	0	0.0000	0.0000	0.0000	0.0000	0.0000	0.0043	0.0043	0.0043	0.0108	0.0108	0.0172	0.0172	0.0172	0.0237	0.0237
tqp-4	0	0.0000	0.0000	0.0011	0.0022	0.0054	0.0075	0.0097	0.0118	0.0140	0.0183	0.0226	0.0248	0.0269	0.0280	0.0312
tqp-5	0	0.0000	0.0000	0.0046	0.0000	0.0092	0.0092	0.0092	0.0138	0.0138	0.0229	0.0229	0.0229	0.0275	0.0275	0.0367
Mid-span-0	0	0.0000	0.0021	0.0000	0.0000	0.0043	0.0064	0.0064	0.0129	0.0129	0.0129	0.0193	0.0193	0.0258	0.0279	0.0343
mid-span-1	0	0.0067	0.0089	0.0089	0.0156	0.0156	0.0156	0.0245	0.0223	0.0290	0.0290	0.0379	0.0379	0.0357	0.0446	0.0513
mid-span-2	0	0.0000	0.0033	0.0044	0.0066	0.0111	0.0144	0.0177	0.0199	0.0221	0.0266	0.0299	0.0321	0.0354	0.0388	0.0443
mid-span-4	0	0.0022	0.0067	0.0078	0.0100	0.0133	0.0156	0.0189	0.0222	0.0256	0.0278	0.0311	0.0334	0.0367	0.0400	0.0456
mid-span-5	0	0.0022	0.0022	0.0022	0.0022	0.0065	0.0065	0.0130	0.0108	0.0173	0.0195	0.0260	0.0260	0.0260	0.0325	0.0303
bqp-1	0	0.0000	0.0000	0.0000	0.0022	0.0055	0.0088	0.0111	0.0133	0.0155	0.0177	0.0199	0.0221	0.0254	0.0276	0.0309
BQP-2	0	0.0000	0.0000	0.0000	0.0000	0.0091	0.0091	0.0091	0.0137	0.0182	0.0137	0.0182	0.0228	0.0182	0.0274	0.0274
BQP-3	0	0.0000	0.0046	0.0046	0.0046	0.0046	0.0138	0.0092	0.0092	0.0183	0.0183	0.0183	0.0229	0.0229	0.0229	0.0321
BQP-4	0	0.0046	0.0046	0.0046	0.0046	0.0046	0.0091	0.0091	0.0137	0.0137	0.0137	0.0228	0.0228	0.0182	0.0273	0.0273
BQP-5	0	0.0022	0.0065	0.0065	0.0065	0.0065	0.0108	0.0151	0.0151	0.0173	0.0238	0.0216	0.0281	0.0281	0.0281	0.0346

Concentrated Load at Mid-Span Continued.

Strain Gage	Load in lbs.												
	8111.6	8702.7	8973.7	9466.3	10008	10533	11001	11477	11929	12438	12873	13267	13013
QPT-1	51.5	56.3	58.2	63.1	67.0	71.8	76.7	82.5	88.3	94.2	101.9	108.7	110.7
QPT-2	64.0	68.9	70.8	75.7	80.5	85.4	88.3	92.2	97.0	102.9	107.7	112.6	160.1
QPT-3	70.0	76.8	79.7	85.5	91.3	97.2	101.0	102.0	102.0	104.0	114.6	121.4	206.0
QPT-4	53.5	56.4	57.3	60.3	63.2	65.1	68.0	69.0	71.9	73.9	76.8	78.7	227.5
QPT-5	65.0	70.8	72.7	77.6	82.4	87.3	91.1	96.0	100.8	104.7	109.6	114.4	107.6
QPT-6	51.5	56.3	59.2	63.1	67.0	71.9	76.7	81.6	86.4	92.2	98.1	101.0	93.2
MS-1	75.7	83.5	86.4	92.2	100.0	107.8	115.5	138.8	168.9	192.2	234.0	289.4	403.0
MS-2	120.4	135.0	140.8	156.4	172.9	192.3	210.8	261.3	327.4	374.1	457.7	491.7	564.6
MS-3	-66.5	-75.0	-78.6	-79.7	-86.2	-91.6	-92.2	-91.3	-101.3	-108.4	-123.5	-138.8	-168.6
MS-4	211.0	221.7	238.2	250.9	250.9	272.3	288.8	290.7	306.3	330.6	365.6	418.2	507.7
MS-5	115.5	128.1	132.9	144.6	164.0	182.4	201.8	243.6	280.5	317.4	381.4	433.9	499.9
MS-6	91.4	100.1	104.0	112.8	123.4	136.1	152.6	177.9	217.8	245.0	288.7	357.8	513.4
QPB-1	60.2	65.1	68.0	72.8	77.7	83.5	88.4	93.2	98.1	103.9	108.8	114.6	118.5
QPB-2	97.0	105.7	109.6	117.4	125.1	131.9	137.8	143.6	148.4	154.3	157.2	160.1	162.0
QPB-3	84.4	91.2	93.1	99.9	105.7	110.6	115.5	124.2	131.0	137.8	150.4	171.7	187.3
QPB-4	91.3	98.1	101.0	107.8	113.6	119.4	124.3	132.1	136.9	144.7	159.3	177.7	194.2
QPB-5	72.9	79.7	82.6	88.5	94.3	100.1	105.0	110.8	115.7	120.5	126.4	135.1	224.6
QPB-6	72.8	79.6	81.6	88.4	94.2	101.0	106.8	113.6	119.4	126.2	134.0	138.9	200.0
Displacement													
TQP-0	0.0302	0.0302	0.0366	0.0366	0.0366	0.0431	0.0453	0.0496	0.0517	0.0582	0.0582	0.0647	0.0776
tqp-1	0.0304	0.0347	0.0326	0.0391	0.0413	0.0413	0.0478	0.0478	0.0543	0.0543	0.0608	0.0673	0.0825
tqp-2	0.0387	0.0420	0.0431	0.0464	0.0508	0.0542	0.0575	0.0608	0.0641	0.0685	0.0741	0.0796	0.0928
tqp-3	0.0280	0.0301	0.0301	0.0387	0.0366	0.0430	0.0430	0.0495	0.0495	0.0559	0.0645	0.0710	0.0839
tqp-4	0.0323	0.0355	0.0377	0.0409	0.0441	0.0484	0.0495	0.0538	0.0581	0.0603	0.0668	0.0732	0.0861
tqp-5	0.0367	0.0367	0.0413	0.0413	0.0413	0.0459	0.0459	0.0550	0.0550	0.0596	0.0688	0.0734	0.0872
Mid-span-0	0.0343	0.0343	0.0408	0.0408	0.0472	0.0472	0.0536	0.0536	0.0601	0.0687	0.0730	0.0815	0.1009
mid-span-1	0.0513	0.0491	0.0580	0.0557	0.0647	0.0624	0.0713	0.0780	0.0825	0.0847	0.0981	0.1048	0.1249
mid-span-2	0.0465	0.0520	0.0543	0.0576	0.0631	0.0675	0.0709	0.0775	0.0853	0.0908	0.1008	0.1118	0.1351
mid-span-4	0.0478	0.0512	0.0534	0.0567	0.0601	0.0645	0.0678	0.0734	0.0790	0.0834	0.0923	0.1023	0.1301
mid-span-5	0.0390	0.0390	0.0455	0.0455	0.0541	0.0541	0.0584	0.0584	0.0671	0.0736	0.0779	0.0866	0.1147
bqp-1	0.0332	0.0354	0.0365	0.0387	0.0409	0.0442	0.0464	0.0508	0.0553	0.0586	0.0630	0.0685	0.0785
BQP-2	0.0319	0.0319	0.0319	0.0411	0.0456	0.0502	0.0456	0.0547	0.0547	0.0639	0.0684	0.0730	0.0821
BQP-3	0.0275	0.0367	0.0413	0.0367	0.0459	0.0459	0.0505	0.0505	0.0596	0.0596	0.0642	0.0734	0.0780
BQP-4	0.0319	0.0319	0.0364	0.0410	0.0410	0.0455	0.0501	0.0501	0.0546	0.0592	0.0592	0.0683	0.0819
BQP-5	0.0346	0.0411	0.0432	0.0432	0.0497	0.0497	0.0475	0.0540	0.0540	0.0627	0.0692	0.0713	0.0843

Slab: Microfiber-MD

Test: Concentrated Load at Bottom Third Point (Figure 5.3-E)

Strain Gage Readings are in $\mu\text{in}/\text{in}$.

Displacement Readings are in inches.

Strain Gage	Load in lbs.														
	0	755.33	1297.2	1600.9	2101.8	2619	2931	3653.5	4064	4507.3	4991.7	5344.8	6149.4	6617.4	7060.7
QPT-1	0	18.5	47.6	67.0	95.2	115.6	124.4	142.8	152.5	165.2	181.7	193.4	220.6	234.2	248.8
QPT-2	0	18.5	43.7	61.2	84.6	101.1	109.8	127.3	138.0	152.6	173.0	186.6	217.8	235.3	250.8
QPT-3	0	17.5	38.0	51.6	75.9	95.4	105.1	125.6	137.2	151.9	171.3	185.0	219.0	236.6	253.1
QPT-4	0	15.6	35.0	46.7	62.3	75.9	83.7	100.3	111.0	125.6	145.1	159.7	193.7	212.2	229.8
QPT-5	0	18.5	42.7	57.3	79.7	101.0	111.7	132.1	143.8	159.3	177.8	191.4	219.6	235.1	247.8
QPT-6	0	19.4	43.7	60.3	80.7	101.1	113.7	136.1	149.7	164.3	183.7	197.3	228.5	243.0	256.6
MS-1	0	21.4	39.8	53.5	81.6	115.7	137.0	183.7	209.0	236.2	267.3	290.6	346.1	380.1	416.1
MS-2	0	19.5	40.9	55.5	85.6	121.6	145.0	195.6	223.8	258.9	296.8	325.1	394.2	438.0	483.8
MS-3	0	-4.4	-9.2	-12.4	-19.8	-28.7	-34.3	-46.7	-53.8	-61.8	-71.2	-77.7	-93.7	-103.5	-113.5
MS-4	0	23.3	41.8	55.5	81.7	115.8	136.2	180.0	205.3	232.6	262.7	288.0	348.4	386.4	427.3
MS-5	0	24.3	46.6	61.2	90.3	130.2	153.5	207.9	238.0	271.1	309.0	337.2	399.4	438.3	480.1
MS-6	0	4.9	11.7	16.5	31.1	55.5	74.0	111.9	130.4	150.9	171.3	184.9	221.0	245.3	269.6
QPB-1	0	4.9	8.7	11.7	15.5	19.4	22.3	28.2	31.1	35.9	40.8	43.7	52.4	58.3	64.1
QPB-2	0	12.6	24.3	31.0	42.7	55.3	63.1	82.5	90.2	101.9	116.4	124.2	143.6	154.3	166.9
QPB-3	0	12.6	24.3	31.0	42.7	54.3	62.1	77.6	84.4	95.1	105.7	111.6	126.1	134.9	143.6
QPB-4	0	13.6	26.2	33.0	44.7	56.3	64.1	80.6	88.4	99.0	111.7	118.5	134.0	144.7	155.4
QPB-5	0	8.7	16.5	20.4	27.2	35.0	40.8	52.5	56.4	65.1	72.9	77.8	88.4	97.2	104.0
QPB-6	0	5.8	10.7	12.6	16.5	20.4	24.3	31.1	32.0	37.9	42.7	43.7	51.5	58.3	64.1
Displacement															
TQP-0	0	0.0065	0.0129	0.0259	0.0409	0.0539	0.0603	0.0797	0.0862	0.1013	0.1142	0.1272	0.1552	0.1681	0.1810
tqp-1	0	0.0000	0.0109	0.0217	0.0347	0.0478	0.0565	0.0760	0.0912	0.0977	0.1173	0.1260	0.1542	0.1694	0.1911
tqp-2	0	0.0055	0.0177	0.0276	0.0431	0.0575	0.0663	0.0884	0.1006	0.1150	0.1304	0.1448	0.1746	0.1912	0.2078
tqp-3	0	0.0022	0.0108	0.0194	0.0387	0.0495	0.0581	0.0774	0.0903	0.1032	0.1183	0.1312	0.1634	0.1763	0.1978
tqp-4	0	0.0043	0.0161	0.0280	0.0452	0.0592	0.0678	0.0883	0.1001	0.1130	0.1303	0.1443	0.1766	0.1916	0.2089
TQP-5	0	0.0046	0.0183	0.0321	0.0459	0.0642	0.0688	0.0917	0.1055	0.1193	0.1330	0.1422	0.1697	0.1881	0.2018
Mid-span-0	0	0.0021	0.0043	0.0129	0.0322	0.0472	0.0601	0.0815	0.0987	0.1137	0.1352	0.1481	0.1803	0.2017	0.2232
mid-span-1	0	0.0111	0.0268	0.0334	0.0535	0.0736	0.0892	0.1093	0.1315	0.1449	0.1672	0.1828	0.2230	0.2430	0.2653
mid-span-2	0	0.0033	0.0155	0.0266	0.0443	0.0675	0.0808	0.1085	0.1262	0.1439	0.1661	0.1827	0.2248	0.2502	0.2746
mid-span-4	0	0.0067	0.0200	0.0300	0.0478	0.0678	0.0801	0.1068	0.1246	0.1412	0.1646	0.1824	0.2213	0.2435	0.2680
mid-span-5	0	0.0022	0.0108	0.0238	0.0368	0.0584	0.0736	0.0974	0.1104	0.1342	0.1515	0.1645	0.2056	0.2294	0.2467
bqp-1	0	0.0000	0.0077	0.0133	0.0232	0.0343	0.0398	0.0542	0.0608	0.0707	0.0818	0.0906	0.1127	0.1227	0.1371
BQP-2	0	0.0000	0.0091	0.0137	0.0274	0.0411	0.0502	0.0639	0.0730	0.0821	0.0958	0.1049	0.1232	0.1414	0.1505
BQP-3	0	0.0000	0.0092	0.0138	0.0275	0.0367	0.0413	0.0596	0.0688	0.0826	0.0872	0.1009	0.1239	0.1376	0.1514
BQP-4	0	0.0000	0.0091	0.0137	0.0228	0.0364	0.0410	0.0546	0.0637	0.0774	0.0910	0.0956	0.1138	0.1275	0.1411
BQP-5	0	0.0022	0.0086	0.0108	0.0238	0.0389	0.0475	0.0584	0.0713	0.0800	0.0929	0.1059	0.1254	0.1426	0.1513

Concentrated Load at Bottom Third Point Continued.

Strain Gage	Load in lbs.						
	7512.3	7955.6	8382.5	9310.3	9737.2	9819.3	9729
QPT-1	260.4	273.0	284.7	321.7	313.9	303.2	297.3
QPT-2	264.4	280.0	293.6	322.8	314.0	296.5	295.6
QPT-3	269.7	285.2	300.8	322.3	333.9	308.6	285.2
QPT-4	245.4	261.9	275.6	297.0	300.9	313.5	290.2
QPT-5	260.4	273.0	282.8	295.4	290.5	285.7	275.0
QPT-6	267.3	277.1	286.8	297.5	287.8	228.5	202.2
MS-1	452.1	493.9	541.6	663.2	770.3	986.4	1091.5
MS-2	529.5	577.3	626.9	680.5	704.9	727.3	723.4
MS-3	-123.6	-133.9	-144.3	-171.4	-167.0	-162.6	-158.4
MS-4	469.1	512.0	558.7	757.5	894.9	938.7	933.9
MS-5	522.9	567.6	616.2	785.5	894.5	811.7	860.4
MS-6	296.9	326.1	360.2	501.4	570.6	466.4	457.6
QPB-1	70.9	76.7	83.5	115.6	133.1	144.7	137.9
QPB-2	179.5	192.1	205.7	242.6	257.1	262.9	257.1
QPB-3	152.3	162.0	171.7	197.0	230.0	236.8	233.8
QPB-4	166.1	177.7	188.4	208.8	219.5	235.0	245.7
QPB-5	112.8	120.5	128.3	146.8	155.5	177.9	176.9
QPB-6	70.9	77.7	84.5	100.0	115.5	126.2	126.2
Displacement							
TQP-0	0.1940	0.2069	0.2263	0.2586	0.2866	0.3190	0.3534
tqp-1	0.2041	0.2193	0.2345	0.2758	0.2975	0.3323	0.3757
tqp-2	0.2233	0.2388	0.2598	0.3007	0.3239	0.3614	0.4079
tqp-3	0.2107	0.2236	0.2430	0.2838	0.3096	0.3569	0.3956
tqp-4	0.2229	0.2401	0.2584	0.2972	0.3219	0.3531	0.3984
TQP-5	0.2202	0.2339	0.2477	0.2844	0.3119	0.3440	0.3899
Mid-span-0	0.2425	0.2640	0.2854	0.3519	0.3992	0.4764	0.5751
mid-span-1	0.2921	0.3121	0.3411	0.4036	0.4526	0.5284	0.6154
mid-span-2	0.3000	0.3244	0.3554	0.4252	0.4728	0.5492	0.6300
mid-span-4	0.2925	0.3169	0.3425	0.4137	0.4604	0.5349	0.6194
mid-span-5	0.2749	0.2965	0.3182	0.3831	0.4307	0.5064	0.5952
bqp-1	0.1503	0.1614	0.1758	0.2122	0.2421	0.2797	0.3272
BQP-2	0.1688	0.1825	0.1962	0.2281	0.2600	0.3011	0.3422
BQP-3	0.1560	0.1697	0.1835	0.2202	0.2477	0.2798	0.3211
BQP-4	0.1502	0.1593	0.1775	0.2094	0.2322	0.2731	0.3141
BQP-5	0.1664	0.1880	0.1967	0.2334	0.2637	0.2853	0.3112

Slab: Microfiber-MD

Test: Concentrated Load at Top Third Point (Figure 5.3-D)

Strain Gage Readings are in $\mu\text{in}/\text{in}$.

Displacement Readings are in inches.

Strain Gage	Load in lbs.									
	0	574.71	1354.6	1962.2	2471.2	3234.8	3489.3	4137.9	4482.7	5114.9
QPT-1	0	9.7	33.0	61.2	88.4	132.1	144.7	178.7	195.2	229.2
QPT-2	0	16.5	49.5	87.4	123.3	180.6	198.1	244.7	268.0	312.7
QPT-3	0	17.5	54.4	93.3	131.2	188.6	206.1	248.9	270.3	313.1
QPT-4	0	17.5	52.5	92.4	129.4	185.8	203.3	251.0	275.3	322.0
QPT-5	0	15.5	48.5	86.3	122.2	176.6	192.1	233.9	255.2	296.9
QPT-6	0	15.5	39.8	65.1	90.3	137.0	151.6	189.4	207.9	246.8
MS-1	0	14.6	39.8	60.2	76.7	102.0	109.8	131.1	141.8	163.2
MS-2	0	12.6	37.9	63.2	86.5	123.4	135.1	167.2	182.7	212.9
MS-3	0	-3.5	-10.3	-16.3	-21.3	-29.9	-32.5	-39.9	-43.7	-50.8
MS-4	0	12.6	35.0	56.4	73.9	104.1	115.8	143.0	157.6	182.9
MS-5	0	17.5	42.7	65.1	85.4	117.5	127.2	154.4	167.0	192.3
MS-6	0	7.8	21.4	34.0	45.7	65.2	72.0	88.5	96.3	110.9
QPB-1	0	3.9	8.7	14.6	19.4	26.2	29.1	35.0	37.9	43.7
QPB-2	0	4.8	11.6	20.4	29.1	44.6	50.4	66.0	73.7	89.2
QPB-3	0	3.9	11.6	21.3	30.1	46.6	51.4	65.0	71.8	85.4
QPB-4	0	4.9	11.7	20.4	28.2	43.7	48.5	62.1	68.0	81.6
QPB-5	0	3.9	9.7	15.5	23.3	36.0	40.8	52.5	58.3	69.0
QPB-6	0	2.9	8.7	13.6	18.4	26.2	28.2	33.0	35.9	40.8
Displacement										
TQP-0	0.0000	0.0022	0.0108	0.0194	0.0323	0.0453	0.0517	0.0647	0.0754	0.0905
tqp-1	0.0065	0.0000	0.0087	0.0152	0.0304	0.0521	0.0586	0.0782	0.0847	0.1042
tqp-2	0.0011	0.0022	0.0133	0.0265	0.0420	0.0663	0.0730	0.0928	0.1050	0.1238
tqp-3	0.0022	0.0022	0.0043	0.0172	0.0387	0.0645	0.0710	0.0903	0.1054	0.1247
tqp-4	0.0011	0.0011	0.0097	0.0269	0.0398	0.0614	0.0700	0.0872	0.0991	0.1184
TQP-5	0.0000	0.0000	0.0092	0.0229	0.0413	0.0596	0.0688	0.0872	0.0917	0.1101
Mid-span-0	0.0064	0.0000	0.0000	0.0129	0.0193	0.0408	0.0451	0.0579	0.0665	0.0815
mid-span-1	0.0022	0.0000	0.0089	0.0223	0.0357	0.0491	0.0557	0.0758	0.0825	0.0959
mid-span-2	0.0022	0.0022	0.0122	0.0244	0.0354	0.0565	0.0642	0.0819	0.0908	0.1096
mid-span-4	0.0022	0.0033	0.0145	0.0267	0.0389	0.0601	0.0656	0.0845	0.0934	0.1112
mid-span-5	0.0065	0.0022	0.0108	0.0195	0.0346	0.0541	0.0606	0.0801	0.0866	0.1061
bqp-1	0.0000	0.0000	0.0033	0.0099	0.0166	0.0276	0.0298	0.0387	0.0431	0.0508
BQP-2	0.0000	0.0000	0.0046	0.0091	0.0137	0.0274	0.0365	0.0456	0.0502	0.0547
BQP-3	0.0046	0.0000	0.0000	0.0092	0.0138	0.0275	0.0321	0.0459	0.0459	0.0596
BQP-4	0.0046	0.0046	0.0046	0.0091	0.0182	0.0273	0.0364	0.0410	0.0501	0.0592
BQP-5	0.0000	0.0022	0.0065	0.0130	0.0216	0.0346	0.0324	0.0497	0.0497	0.0605

Concentrated Load at Top Third Point Continued.

Strain Gage	Load in lbs.										
	5574.7	5919.5	6461.4	7159.2	7471.2	7840.7	8144.4	8333.3	8809.5	9269.2	9154.3
QPT-1	254.5	273.9	304.0	341.9	360.4	388.5	416.7	436.2	507.1	591.7	619.9
QPT-2	346.7	373.9	416.6	473.0	499.2	536.2	574.1	601.3	722.8	882.3	935.8
QPT-3	344.2	368.5	408.4	459.9	484.3	518.3	555.3	579.6	682.8	822.9	874.5
QPT-4	357.0	384.3	428.1	484.6	509.9	545.9	580.9	610.1	723.1	878.0	937.4
QPT-5	327.0	350.3	385.3	433.8	456.2	489.2	523.2	548.4	656.2	802.9	858.3
QPT-6	275.0	297.3	331.3	377.0	399.4	432.4	465.5	487.9	572.5	679.4	718.4
MS-1	177.8	190.4	211.8	245.8	266.2	296.3	328.4	352.7	431.4	518.9	551.0
MS-2	235.3	253.7	281.9	326.7	352.9	390.9	434.6	469.6	577.6	694.4	735.3
MS-3	-55.9	-60.3	-66.5	-76.2	-81.3	-88.1	-94.9	-99.6	-112.0	-123.8	-125.9
MS-4	202.4	222.8	248.1	286.0	307.5	335.7	373.6	387.3	438.9	494.4	505.1
MS-5	210.7	225.3	247.6	288.4	313.7	351.6	390.4	415.7	488.6	570.2	589.7
MS-6	122.6	132.3	147.9	178.0	196.5	223.8	253.0	272.5	327.9	383.4	400.0
QPB-1	48.6	51.5	58.3	64.1	68.9	74.8	81.6	85.5	100.0	112.7	115.6
QPB-2	100.9	109.6	123.2	132.9	135.8	140.7	143.6	146.5	153.3	158.1	151.3
QPB-3	95.1	101.9	113.5	124.2	127.1	131.9	135.8	139.7	150.4	163.0	164.0
QPB-4	91.3	98.1	109.7	121.4	124.3	128.2	130.1	133.0	139.8	148.6	149.5
QPB-5	76.8	81.6	89.4	98.2	102.1	107.9	110.8	113.7	122.5	131.2	131.2
QPB-6	44.7	46.6	50.5	57.3	60.2	65.0	68.9	71.8	80.6	88.3	89.3
Displacement											
TQP-0	0.0970	0.1121	0.1250	0.1444	0.1595	0.1724	0.1918	0.2047	0.2522	0.3103	0.3319
tqp-1	0.1151	0.1281	0.1433	0.1694	0.1824	0.1998	0.2280	0.2432	0.2975	0.3627	0.3844
tqp-2	0.1393	0.1525	0.1724	0.2001	0.2178	0.2421	0.2686	0.2863	0.3504	0.4289	0.4576
tqp-3	0.1376	0.1505	0.1699	0.2043	0.2172	0.2430	0.2688	0.2903	0.3634	0.4494	0.4838
tqp-4	0.1335	0.1443	0.1647	0.1895	0.2078	0.2272	0.2519	0.2713	0.3338	0.4113	0.4393
TQP-5	0.1239	0.1376	0.1560	0.1835	0.1972	0.2202	0.2431	0.2615	0.3211	0.3899	0.4174
Mid-span-0	0.0880	0.0987	0.1159	0.1352	0.1502	0.1695	0.1953	0.2103	0.2661	0.3262	0.3477
mid-span-1	0.1115	0.1249	0.1382	0.1672	0.1806	0.2074	0.2341	0.2519	0.3166	0.3857	0.4147
mid-span-2	0.1240	0.1362	0.1528	0.1794	0.1982	0.2259	0.2580	0.2801	0.3499	0.4340	0.4628
mid-span-4	0.1268	0.1368	0.1557	0.1846	0.2024	0.2280	0.2569	0.2769	0.3470	0.4226	0.4504
mid-span-5	0.1212	0.1277	0.1472	0.1753	0.1883	0.2143	0.2424	0.2640	0.3333	0.4069	0.4350
bqp-1	0.0575	0.0630	0.0718	0.0851	0.0940	0.1072	0.1205	0.1326	0.1669	0.2034	0.2144
BQP-2	0.0639	0.0684	0.0730	0.0958	0.1004	0.1141	0.1277	0.1414	0.1779	0.2190	0.2327
BQP-3	0.0642	0.0734	0.0780	0.0917	0.1009	0.1147	0.1284	0.1422	0.1743	0.2202	0.2339
BQP-4	0.0683	0.0683	0.0819	0.0956	0.1002	0.1138	0.1320	0.1411	0.1730	0.2185	0.2322
BQP-5	0.0670	0.0735	0.0821	0.1016	0.1102	0.1232	0.1426	0.1491	0.1902	0.2334	0.2464

Slab: Microfiber-MD

Test: Longitudinal Linear Load along Middle Strip (Figure 5.3-F)

Strain Gage Readings are in $\mu\text{in}/\text{in}$.

Displacement Readings are in inches.

Strain Gage	Load in lbs.												
	0	1174	2110	3136.2	4252.8	5254.5	5853.8	7192.1	8054.1	8891.6	9868.6	10221	10385
QPT-1	0	47.6	85.5	118.5	147.7	172.0	185.6	230.3	278.9	344.1	420.9	463.7	492.8
QPT-2	0	87.5	143.9	182.8	218.7	249.8	269.3	332.5	399.6	486.2	579.6	624.4	656.5
QPT-3	0	62.3	102.2	132.4	158.7	189.8	212.2	291.1	369.0	466.4	582.3	643.7	681.7
QPT-4	0	66.2	109.0	140.2	169.4	197.6	217.1	280.4	347.6	431.4	523.0	565.9	588.3
QPT-5	0	82.6	136.0	175.8	212.8	247.8	270.1	333.3	391.6	460.6	536.5	573.4	604.6
QPT-6	0	60.3	104.0	137.0	167.2	198.3	216.8	273.1	328.6	399.6	489.1	533.8	558.1
MS-1	0	37.0	68.1	104.1	141.1	174.2	194.7	242.4	278.4	319.3	394.3	525.8	786.0
MS-2	0	37.0	70.1	109.0	150.9	192.7	217.1	279.4	325.2	378.8	458.6	494.7	513.2
MS-3	0	-6.5	-13.3	-22.2	-32.5	-42.6	-48.8	-63.3	-73.3	-85.4	-103.8	-112.1	-113.2
MS-4	0	32.1	60.4	93.5	129.5	165.5	189.9	249.3	290.2	337.0	412.0	451.0	472.4
MS-5	0	34.0	64.2	100.1	141.0	179.9	203.2	258.7	300.5	351.1	430.8	468.8	501.9
MS-6	0	17.5	36.0	63.3	98.3	134.3	155.8	198.6	222.9	249.2	281.4	280.4	252.2
QPB-1	0	7.8	14.6	23.3	33.0	42.7	46.6	57.3	64.1	69.0	72.8	72.8	72.8
QPB-2	0	13.6	26.2	41.7	62.1	84.4	98.0	133.9	158.1	185.3	209.6	213.5	217.3
QPB-3	0	14.6	29.1	45.6	64.0	84.4	95.1	123.2	141.7	160.1	180.5	184.4	189.2
QPB-4	0	14.6	28.2	43.7	62.1	82.5	95.2	124.3	144.7	166.1	186.5	187.4	187.4
QPB-5	0	13.6	25.3	36.0	50.5	68.0	77.8	100.1	113.7	124.4	135.1	140.0	145.8
QPB-6	0	8.7	15.5	23.3	34.9	46.6	51.5	65.0	72.8	78.6	85.4	91.3	96.1
Displacement													
TQP-0	0	0.0172	0.0323	0.0453	0.0517	0.0668	0.0733	0.0991	0.1336	0.1789	0.2392	0.2802	0.3319
tqp-1	0	0.0174	0.0391	0.0456	0.0608	0.0738	0.0804	0.1173	0.1455	0.1933	0.2584	0.3084	0.3648
tqp-2	0	0.0287	0.0497	0.0630	0.0785	0.0940	0.1050	0.1404	0.1758	0.2255	0.2940	0.3504	0.4123
tqp-3	0	0.0151	0.0366	0.0559	0.0710	0.0839	0.0968	0.1290	0.1656	0.2150	0.2881	0.3419	0.4086
tqp-4	0	0.0248	0.0452	0.0603	0.0711	0.0851	0.0926	0.1238	0.1647	0.2207	0.2875	0.3467	0.4081
TQP-5	0	0.0275	0.0459	0.0550	0.0688	0.0780	0.0872	0.1147	0.1514	0.2018	0.2661	0.3165	0.3761
Mid-span-0	0	0.0064	0.0193	0.0300	0.0386	0.0536	0.0601	0.0880	0.1159	0.1545	0.2232	0.2854	0.3820
mid-span-1	0	0.0201	0.0334	0.0491	0.0602	0.0803	0.0892	0.1226	0.1516	0.1940	0.2631	0.3255	0.4125
mid-span-2	0	0.0199	0.0388	0.0554	0.0731	0.0919	0.1030	0.1362	0.1716	0.2192	0.3012	0.3731	0.4661
mid-span-4	0	0.0222	0.0400	0.0545	0.0701	0.0845	0.0945	0.1268	0.1590	0.2080	0.2780	0.3447	0.4382
mid-span-5	0	0.0152	0.0303	0.0476	0.0606	0.0801	0.0844	0.1190	0.1472	0.1948	0.2684	0.3420	0.4394
bqp-1	0	0.0088	0.0221	0.0276	0.0365	0.0464	0.0508	0.0696	0.0873	0.1083	0.1437	0.1758	0.2178
BQP-2	0	0.0137	0.0182	0.0319	0.0456	0.0547	0.0593	0.0821	0.1004	0.1277	0.1642	0.2007	0.2464
BQP-3	0	0.0138	0.0183	0.0321	0.0413	0.0550	0.0642	0.0780	0.0963	0.1239	0.1606	0.1972	0.2385
BQP-4	0	0.0000	0.0091	0.0182	0.0273	0.0410	0.0410	0.0592	0.0819	0.1002	0.1411	0.1730	0.2140
BQP-5	0	0.0086	0.0195	0.0281	0.0346	0.0411	0.0475	0.0692	0.0843	0.1081	0.1426	0.1772	0.2183

Slab: Microfiber-MD

Test: Longitudinal Linear Load along Left Third Point Strip (Figure 5.3-G)

Strain Gage readings are in $\mu\text{in/in}$.

Displacement Readings are in inches.

Strain Gage	Load in lbs.										
	0	1091.9	2183.9	3045.9	3981.9	5361.2	6239.7	7118.2	7963.8	8776.6	9302.1
QPT-1	0	41.8	109.8	159.4	201.2	247.9	274.1	299.4	327.6	377.2	406.3
QPT-2	0	66.1	166.2	225.6	273.2	324.8	349.1	371.5	393.8	435.7	469.7
QPT-3	0	56.5	142.1	198.6	245.4	304.8	337.9	369.1	400.2	446.0	473.3
QPT-4	0	52.6	131.4	180.1	219.1	269.7	300.9	330.1	361.3	392.5	412.9
QPT-5	0	60.2	150.6	201.1	241.9	294.4	327.5	356.7	377.1	396.5	413.0
QPT-6	0	41.8	110.8	147.7	175.9	217.7	245.9	270.3	289.7	296.5	295.5
MS-1	0	36.0	75.0	111.0	151.0	207.5	243.5	281.6	326.4	479.4	909.5
MS-2	0	36.0	80.8	119.7	161.6	221.0	260.9	303.8	348.6	423.6	482.0
MS-3	0	-7.4	-16.3	-24.5	-34.3	-50.0	-60.9	-73.0	-86.0	-105.5	-117.7
MS-4	0	27.3	62.3	90.5	118.8	169.4	206.4	250.3	302.9	369.1	425.6
MS-5	0	34.0	75.8	107.9	141.9	200.3	244.0	292.7	348.1	407.5	447.3
MS-6	0	24.3	47.7	62.3	77.8	115.8	147.9	184.9	226.7	267.6	279.3
QPB-1	0	9.7	21.4	32.0	42.7	62.2	72.8	83.5	94.2	107.8	116.5
QPB-2	0	15.5	34.9	53.4	71.8	101.9	120.3	139.7	158.1	175.6	187.3
QPB-3	0	11.6	27.2	40.7	57.2	82.5	99.9	117.4	135.8	152.3	163.0
QPB-4	0	9.7	23.3	35.9	49.5	71.9	87.4	105.8	125.3	142.8	152.5
QPB-5	0	5.8	14.6	22.4	30.1	47.6	62.2	80.7	100.1	111.8	118.6
QPB-6	0	5.8	12.6	16.5	21.4	28.2	33.0	33.0	29.1	23.3	23.3
Displacement											
TQP-0	0.0022	0.0172	0.0517	0.0776	0.1056	0.1379	0.1659	0.1918	0.2198	0.2651	0.3190
tqp-1	0.0022	0.0109	0.0521	0.0738	0.0956	0.1303	0.1520	0.1737	0.1954	0.2454	0.3019
tqp-2	0.0011	0.0177	0.0564	0.0818	0.1017	0.1326	0.1547	0.1758	0.1979	0.2443	0.2984
tqp-3	0.0022	0.0043	0.0387	0.0645	0.0860	0.1118	0.1247	0.1441	0.1634	0.2043	0.2580
tqp-4	0.0011	0.0151	0.0484	0.0711	0.0894	0.1077	0.1206	0.1335	0.1475	0.1841	0.2347
TQP-5	0.0000	0.0046	0.0367	0.0596	0.0780	0.0963	0.1101	0.1147	0.1284	0.1606	0.2064
Mid-span-0	0.0021	0.0064	0.0386	0.0665	0.0880	0.1266	0.1481	0.1803	0.2232	0.2919	0.3863
mid-span-1	0.0000	0.0134	0.0491	0.0691	0.0914	0.1249	0.1516	0.1784	0.2074	0.2765	0.3590
mid-span-2	0.0011	0.0188	0.0509	0.0742	0.0963	0.1295	0.1528	0.1783	0.2104	0.2713	0.3620
mid-span-4	0.0000	0.0122	0.0378	0.0556	0.0712	0.0934	0.1101	0.1268	0.1490	0.2046	0.2825
mid-span-5	0.0043	0.0108	0.0325	0.0519	0.0649	0.0844	0.1017	0.1125	0.1342	0.1796	0.2640
bqp-1	0.0000	0.0099	0.0287	0.0420	0.0553	0.0763	0.0895	0.1061	0.1260	0.1625	0.2100
BQP-2	0.0000	0.0091	0.0182	0.0319	0.0456	0.0639	0.0776	0.0912	0.1141	0.1460	0.1825
BQP-3	0.0000	0.0000	0.0229	0.0275	0.0413	0.0550	0.0642	0.0780	0.0917	0.1193	0.1560
BQP-4	0.0046	0.0046	0.0046	0.0182	0.0228	0.0319	0.0455	0.0501	0.0592	0.0865	0.1184
BQP-5	0.0022	0.0043	0.0130	0.0195	0.0346	0.0389	0.0454	0.0519	0.0627	0.0865	0.1297

Slab: Microfiber-MD

Test: Longitudinal Linear Load along Right Third Point Strip (Figure 5.3-H)

Strain Gage Readings are in $\mu\text{in}/\text{in}$.

Displacement Readings are in inches.

Strain Gage	Load in lbs.									
	0	1174	2019.7	3316.9	4269.2	5123.1	5968.8	6863.7	7832.5	7684.7
QPT-1	0	45.7	89.4	141.9	169.1	190.5	210.9	221.6	230.3	226.5
QPT-2	0	89.4	161.4	235.3	272.2	303.3	336.4	378.2	431.7	424.0
QPT-3	0	80.8	146.0	216.1	254.1	288.2	329.1	385.6	441.1	433.3
QPT-4	0	80.8	140.2	207.4	246.3	284.3	329.1	380.8	410.0	400.3
QPT-5	0	101.0	176.8	255.5	300.2	342.0	382.9	426.6	488.8	480.1
QPT-6	0	73.9	135.1	203.1	241.1	276.1	318.8	386.0	454.0	446.3
MS-1	0	33.2	57.5	103.4	137.5	168.7	203.9	266.3	409.7	419.5
MS-2	0	40.9	74.9	129.5	168.4	204.4	242.4	309.6	431.3	425.5
MS-3	0	-9.2	-16.9	-30.2	-40.5	-50.5	-61.2	-78.0	-103.5	-101.4
MS-4	0	37.0	68.1	117.8	157.7	195.7	237.6	301.9	407.1	400.3
MS-5	0	52.5	95.3	161.4	211.0	257.6	305.3	379.2	488.2	480.4
MS-6	0	35.0	63.2	108.0	142.0	174.1	207.2	261.7	341.5	333.7
QPB-1	0	7.8	13.6	24.3	30.1	33.0	32.0	28.2	25.2	24.3
QPB-2	0	10.7	19.4	37.8	53.4	68.9	86.3	106.7	131.9	131.0
QPB-3	0	13.6	26.2	49.5	66.9	84.4	101.9	120.3	139.7	137.8
QPB-4	0	14.6	29.1	52.4	71.9	89.3	107.8	123.3	136.9	135.0
QPB-5	0	13.6	25.3	44.7	60.3	75.8	92.3	107.9	130.3	128.3
QPB-6	0	11.6	24.3	46.6	63.1	77.7	93.2	108.7	128.2	127.2
Displacement										
TQP-0	0	0.0194	0.0345	0.0560	0.0647	0.0733	0.0819	0.1078	0.1746	0.1746
tqp-1	0	0.0152	0.0369	0.0565	0.0717	0.0782	0.0934	0.1281	0.2063	0.2063
tqp-2	0	0.0276	0.0564	0.0851	0.1017	0.1161	0.1349	0.1769	0.2664	0.2686
tqp-3	0	0.0194	0.0538	0.0860	0.1054	0.1269	0.1527	0.1935	0.2924	0.2989
tqp-4	0	0.0345	0.0668	0.1044	0.1260	0.1507	0.1809	0.2283	0.3327	0.3338
TQP-5	0	0.0367	0.0688	0.1147	0.1330	0.1606	0.1927	0.2431	0.3532	0.3532
Mid-span-0	0	0.0064	0.0172	0.0386	0.0451	0.0536	0.0665	0.1009	0.2296	0.2361
mid-span-1	0.00223	0.0201	0.0379	0.0624	0.0758	0.0914	0.1048	0.1472	0.2698	0.2765
mid-span-2	0.001107	0.0199	0.0432	0.0698	0.0864	0.1041	0.1262	0.1771	0.3155	0.3233
mid-span-4	0	0.0300	0.0578	0.0923	0.1157	0.1401	0.1701	0.2257	0.3737	0.3803
mid-span-5	0.002164	0.0325	0.0671	0.1104	0.1364	0.1623	0.1970	0.2576	0.4134	0.4177
bqp-1	0.001105	0.0066	0.0166	0.0276	0.0354	0.0420	0.0486	0.0685	0.1360	0.1393
BQP-2	0	0.0091	0.0228	0.0411	0.0502	0.0639	0.0684	0.0958	0.1597	0.1688
BQP-3	0	0.0138	0.0275	0.0505	0.0642	0.0780	0.0917	0.1193	0.1881	0.1881
BQP-4	0	0.0091	0.0273	0.0546	0.0683	0.0819	0.1002	0.1275	0.2049	0.2049
BQP-5	0	0.0195	0.0411	0.0692	0.0821	0.1037	0.1232	0.1578	0.2399	0.2377

APPENDIX G

PUSH-OUT TESTS SUMMARY OF RESULTS

The results from the push-out tests are presented in this Appendix. There is a set of results for every specimen tested, which includes a data table, test parameters, figure of the failure mode and graphs of the applied shear load vs. slip for both sides of the specimen.

PUSHOUT TEST SUMMARY SHEET

Test: WWF-Screw-1
 Test Designation:

Test Date: 16-Jul-01

SPECIMEN DESCRIPTION			
Screw:	Height: <u>3.0 in.</u>	No. Per Specimen: <u>10</u>	
Deck:	Type: <u>1.5VL, 22 ga</u>	Width: <u>36 in.</u>	Length: <u>36 in.</u>
	F _y : <u>54 ksi</u>	F _u : <u>63 ksi</u>	
Base Member:	Section: <u>2L 2.00x2.00x0.187</u>		
	F _y : <u>69 ksi</u>	F _u : <u>88.5 ksi</u>	
Slab:	Thickness: <u>3.50 in.</u>	f' _c : <u>3400 psi</u>	
Rebar:	Size: <u>No. 4</u>	No. Per Specimen: <u>8</u>	
		Height Above Deck: <u>0.75 in.</u>	
Mesh:	Type: <u>WWF 6x6-W2.9xW2.9</u>		

TEST RESULTS			
Peak Shear Load: <u>50.53 kips</u>			
Peak Shear Load Per Screw: <u>5.05 kips</u>			
Slip at Peak Shear Load:	SC1: <u>0.8126 in.</u>	SC5: <u>0.6855 in.</u>	
	SC2: <u>0.9266 in.</u>	SC6: <u>0.4607 in.</u>	
	SC3: <u>0.8844 in.</u>	SC7: <u>0.7721 in.</u>	
	SC4: <u>0.8827 in.</u>	SC8: <u>0.7476 in.</u>	

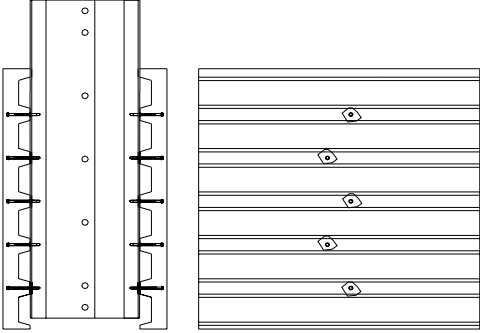
DAMAGE	
 <p>exterior, Slab B</p>	 <p>interior, Slab A</p>

COMMENTS
Failure Mode: Screw Shear Screw Rotation ≈ 30° - 40° X = Screw sheared off

Table G-1 WWF-Screw-1 Test Data

TEST WWF-Screw-1									
DATA									
Shear	Normal	Slip							
Load	Load	(in)							
(kips)	(kips)	SC-1	SC-2	SC-3	SC-4	SC-5	SC-6	SC-7	SC-8
0.00	0.00	0.000	0.000	0.000	0.000	0.000	-0.001	-0.001	0.000
3.79	0.91	0.000	0.004	0.000	0.001	0.000	0.000	0.000	0.000
9.81	0.92	0.000	0.004	0.000	0.001	-0.001	0.000	0.000	0.000
14.21	1.14	0.001	0.023	0.004	0.007	0.000	0.000	0.003	0.001
18.57	1.89	0.000	0.027	0.004	0.007	0.000	0.000	0.004	0.000
23.29	1.86	0.000	0.044	0.015	0.017	0.000	0.000	0.013	0.004
27.36	3.07	0.013	0.075	0.042	0.038	0.000	0.001	0.030	0.022
30.09	3.53	0.038	0.106	0.070	0.063	0.000	0.000	0.042	0.033
32.61	4.11	0.114	0.194	0.152	0.144	0.009	0.001	0.076	0.069
34.69	4.01	0.183	0.272	0.229	0.227	0.078	0.001	0.150	0.144
37.42	4.50	0.276	0.377	0.329	0.334	0.161	0.001	0.242	0.243
39.66	4.66	0.364	0.470	0.421	0.428	0.243	0.031	0.322	0.331
41.49	4.96	0.431	0.539	0.487	0.497	0.307	0.095	0.381	0.396
42.92	4.83	0.463	0.572	0.525	0.532	0.340	0.123	0.413	0.427
44.71	5.19	0.519	0.628	0.582	0.588	0.400	0.174	0.479	0.480
46.54	5.30	0.597	0.708	0.663	0.666	0.480	0.258	0.564	0.557
48.09	5.71	0.667	0.778	0.733	0.735	0.548	0.322	0.635	0.620
49.76	5.90	0.753	0.867	0.823	0.820	0.631	0.410	0.718	0.697
49.67	5.90	0.753	0.866	0.824	0.821	0.631	0.410	0.719	0.698
50.53	6.17	0.8126	0.9266	0.8844	0.8827	0.6855	0.4607	0.7721	0.7476

Test WWF-Screw-1: Load vs. Slip (A)

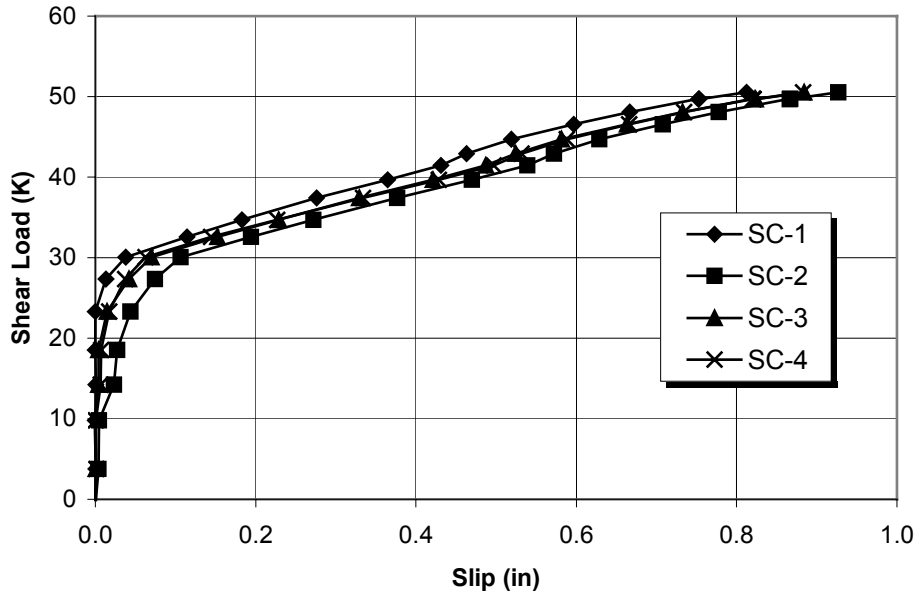

Test WWF-Screw-1: Load vs. Slip (B)

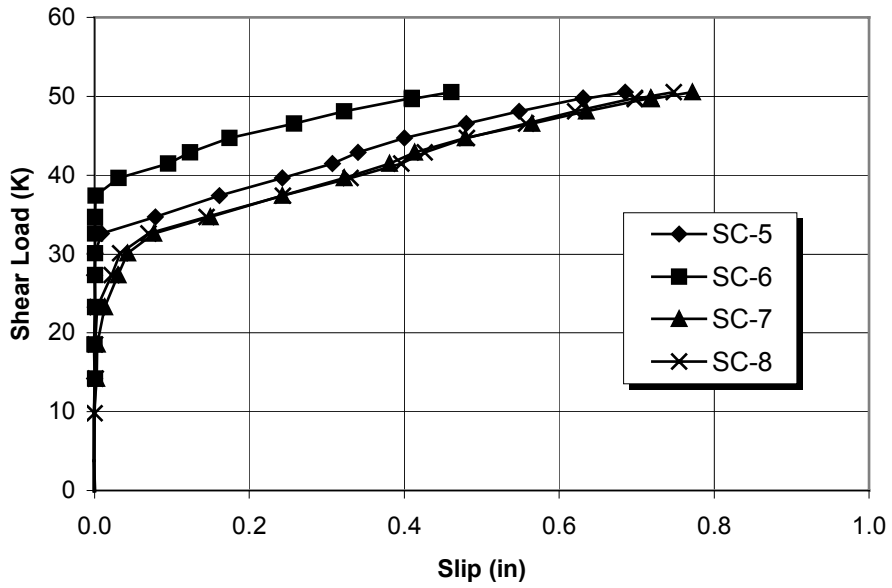

Figure G-1 WWF-Screw-1 Applied Shear Load vs. Slip

PUSHOUT TEST SUMMARY SHEET

Test: WWF-Screw-2
 Test Designation:

Test Date: 16-Jul-01

SPECIMEN DESCRIPTION			
Screw:	Height: <u>3.0 in.</u>	No. Per Specimen: <u>10</u>	
Deck:	Type: <u>1.5VL, 22 ga</u>	Width: <u>36 in.</u>	Length: <u>36 in.</u>
	F _y : <u>54 ksi</u>	F _u : <u>63 ksi</u>	
Base Member:	Section: <u>2L 2.00x2.00x0.187</u>		
	F _y : <u>69 ksi</u>	F _u : <u>88.5 ksi</u>	
Slab:	Thickness: <u>3.50 in.</u>	f' _c : <u>3400 psi</u>	
Rebar:	Size: <u>No. 4</u>	No. Per Specimen: <u>8</u>	
		Height Above Deck: <u>0.75 in.</u>	
Mesh:	Type: <u>WWF 6x6-W2.9xW2.9</u>		

TEST RESULTS			
Peak Shear Load: <u>51.43 kips</u>			
Peak Shear Load Per Screw: <u>5.14 kips</u>			
Slip at Peak Shear Load:	SC1: <u>0.890 in.</u>	SC5: <u>0.564 in.</u>	
	SC2: <u>0.910 in.</u>	SC6: <u>0.306 in.</u>	
	SC3: <u>0.8640 in.</u>	SC7: <u>0.460 in.</u>	
	SC4: <u>0.895 in.</u>	SC8: <u>0.727 in.</u>	

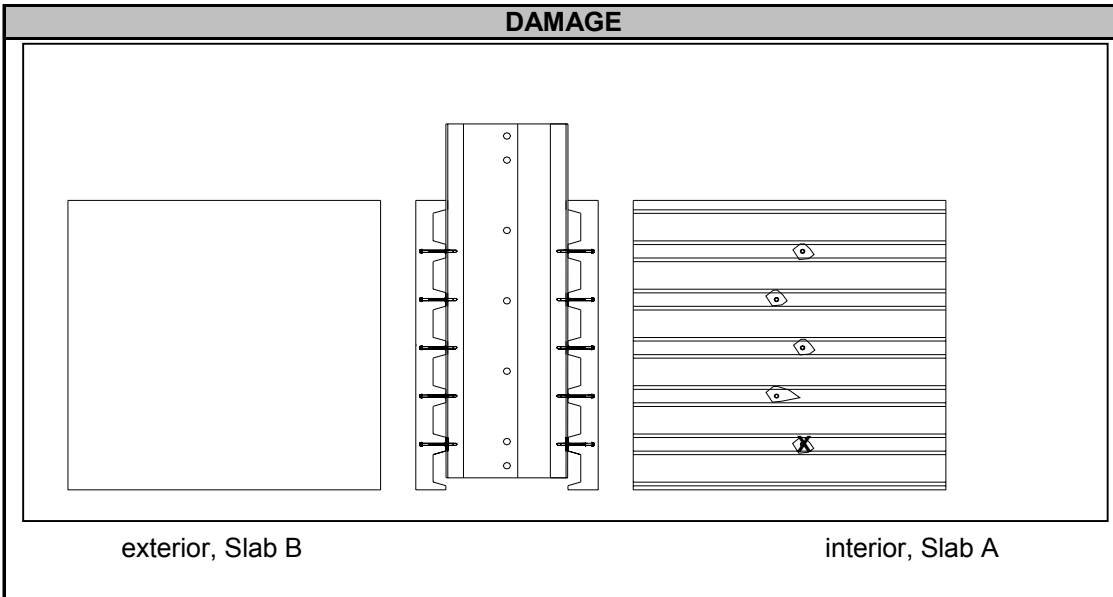

COMMENTS
Failure Mode: Screw Shear Screw Rotation ≈ 30° - 40° X = Screw sheared off

Table G-2 WWF-Screw-2 Test Data

TEST WWF-Screw-2 DATA									
Shear	Normal	Slip							
Load	Load	(in)							
(kips)	(kips)	SC-1	SC-2	SC-3	SC-4	SC-5	SC-6	SC-7	SC-8
-0.04	0.01	0.000	-0.001	0.000	0.000	0.000	0.000	0.000	0.000
-0.04	0.00	-0.001	0.000	0.000	0.000	0.000	-0.001	0.001	0.000
6.51	1.38	-0.001	0.003	0.000	0.005	0.000	0.003	0.000	0.000
11.48	1.24	0.000	0.007	0.000	0.010	0.000	0.006	0.003	0.001
15.15	1.45	0.001	0.010	0.000	0.015	0.000	0.014	0.005	0.002
19.06	2.07	0.003	0.019	0.001	0.025	0.000	0.021	0.009	0.008
27.16	2.81	0.051	0.080	0.029	0.091	0.000	0.063	0.038	0.048
29.28	3.14	0.081	0.115	0.055	0.127	0.000	0.089	0.059	0.076
32.94	3.69	0.258	0.301	0.232	0.314	0.100	0.260	0.199	0.244
34.98	4.01	0.319	0.364	0.289	0.377	0.147	0.321	0.247	0.304
37.09	4.08	0.422	0.466	0.392	0.476	0.219	0.312	0.317	0.393
40.23	4.36	0.585	0.623	0.558	0.626	0.331	0.310	0.387	0.535
40.27	4.36	0.586	0.622	0.559	0.627	0.331	0.311	0.387	0.535
45.07	4.80	0.733	0.763	0.706	0.754	0.438	0.308	0.391	0.666
51.43	4.27	0.890	0.910	0.864	0.895	0.564	0.306	0.460	0.727
47.72	4.95	0.954	0.967	0.921	0.952	0.657	0.306		0.766

Test WWF-Screw-2: Load vs. Slip (A)

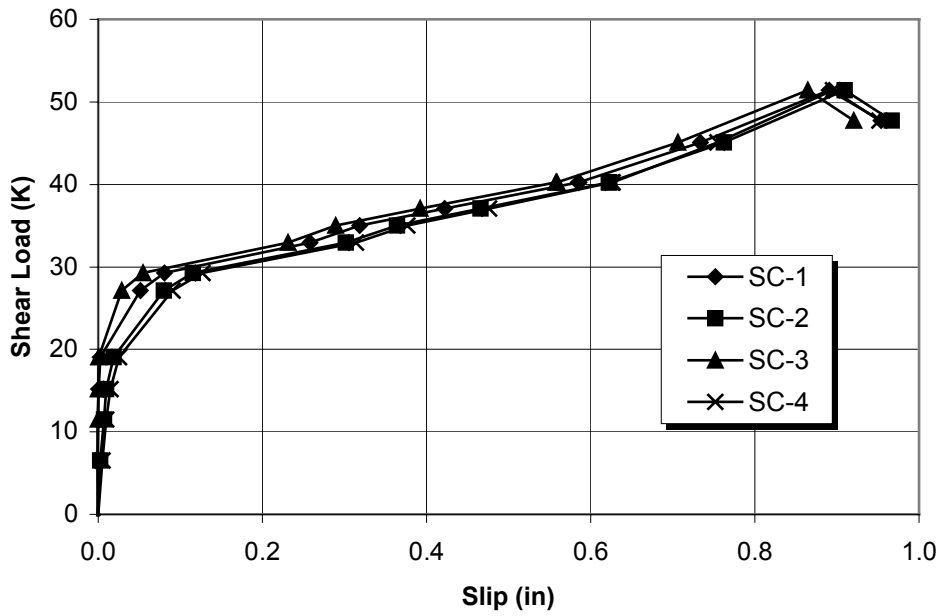

Test WWF-Screw-2: Load vs. Slip (B)

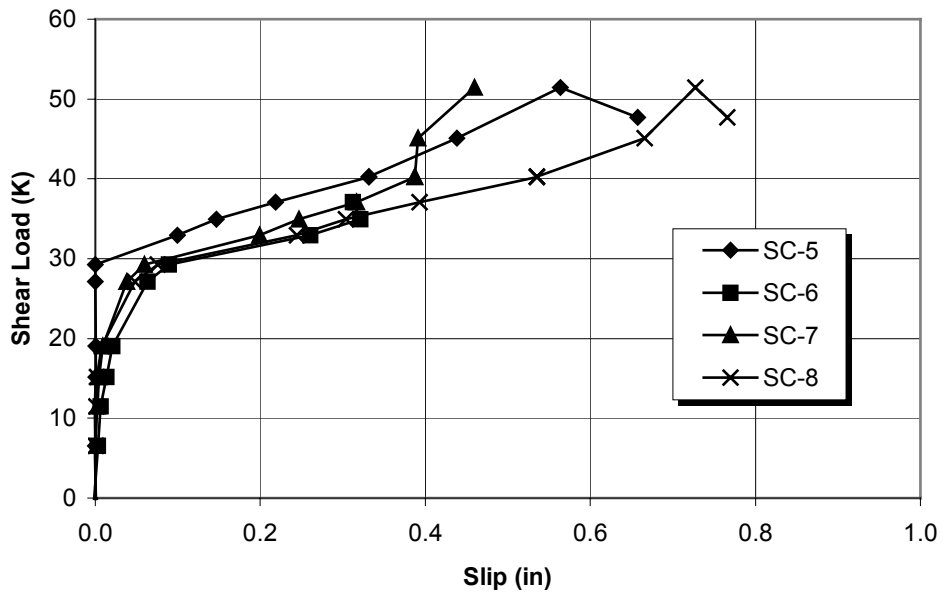

Figure G-2 WWF-Screw-2 Applied Shear Load vs. Slip

Table G-3 XOREX25-Screw-1 Test Data

PUSHOUT TEST SUMMARY SHEET

Test: XOREX-25-Screw-1

Test Date: 16-Jul-01

SPECIMEN DESCRIPTION			
Screw:	Height: <u>3.0 in.</u>	No. Per Specimen: <u>10</u>	
Deck:	Type: <u>1.5VL, 22 ga</u>	Width: <u>36 in.</u>	Length: <u>36 in.</u>
	F_y : <u>54 ksi</u>	F_u : <u>63 ksi</u>	
Base Member:	Section: <u>2L 2.00x2.00x0.187</u>		
	F_y : <u>69 ksi</u>	F_u : <u>88.5 ksi</u>	
Slab:	Thickness: <u>3.50 in.</u>	f'_c : <u>3600 psi</u>	
Rebar:	Size: <u>No. 4</u>	No. Per Specimen: <u>8</u>	Height Above Deck: <u>0.75 in.</u>
Mesh:	Type: <u>WWF 6x6-W2.9xW2.9</u>		

TEST RESULTS		
Peak Shear Load:	<u>57.25 kips</u>	
Peak Shear Load Per Screw:	<u>5.725 kips</u>	
Slip at Peak Shear Load:	SC1: <u>0.636 in.</u>	SC5: <u>0.617 in.</u>
	SC2: <u>0.676 in.</u>	SC6: <u>0.754 in.</u>
	SC3: <u>0.667 in.</u>	SC7: <u>0.642 in.</u>
	SC4: <u>0.770 in.</u>	SC8: <u>0.712 in.</u>

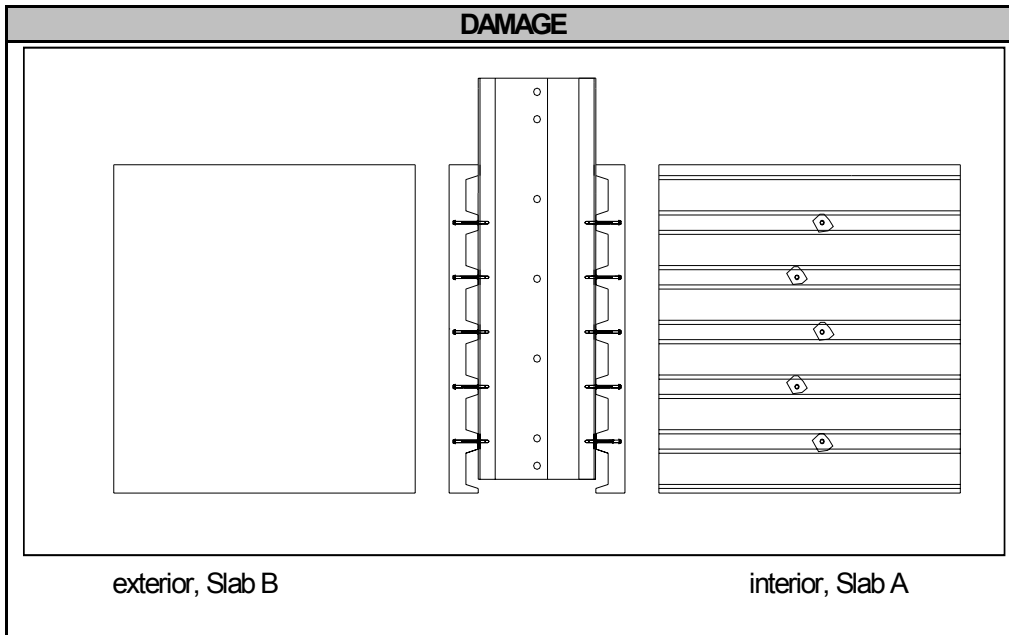

COMMENTS
Failure Mode: Screw Shear Screw Rotation $\approx 30^\circ - 40^\circ$ X = Screw sheared off

TEST XOREX-25- Screw-1 DATA									
Shear	Normal	Slip							
Load	Load	(in)							
(kips)	(kips)	SC-1	SC-2	SC-3	SC-4	SC-5	SC-6	SC-7	SC-8
0.69	0.02	0.000	-0.001	0.000	0.000	0.000	-0.001	0.000	-0.001
5.70	0.51	0.000	-0.001	-0.001	0.011	0.000	-0.001	-0.001	0.001
10.67	0.95	0.000	0.000	0.000	0.020	0.000	-0.001	-0.001	0.001
14.13	1.49	0.000	-0.001	0.000	0.020	-0.003	-0.001	0.001	0.002
22.15	1.90	0.000	0.000	0.012	0.042	-0.010	0.020	0.011	0.021
25.90	2.75	0.000	0.000	0.019	0.053	-0.014	0.032	0.018	0.029
29.72	3.30	0.009	0.001	0.030	0.070	-0.014	0.048	0.030	0.045
31.80	3.56	0.015	0.005	0.040	0.088	-0.010	0.064	0.040	0.060
34.20	3.83	0.056	0.053	0.079	0.139	0.026	0.111	0.073	0.104
37.34	4.26	0.165	0.175	0.184	0.261	0.122	0.226	0.152	0.213
40.19	4.84	0.227	0.246	0.250	0.337	0.188	0.297	0.211	0.279
43.04	5.05	0.283	0.306	0.306	0.399	0.246	0.360	0.269	0.339
46.58	5.30	0.364	0.392	0.389	0.483	0.332	0.451	0.356	0.426
48.86	5.52	0.415	0.445	0.441	0.540	0.392	0.514	0.416	0.486
51.34	5.94	0.469	0.503	0.499	0.595	0.452	0.577	0.477	0.546
55.13	6.49	0.564	0.603	0.595	0.697	0.547	0.681	0.573	0.642
57.25	6.72	0.636	0.676	0.667	0.770	0.617	0.754	0.642	0.712
46.70	6.55	1.031	1.056	1.044	1.150	1.034	1.158	1.058	1.105

Test XOREX25-Screw-1: Load vs. Slip (A)

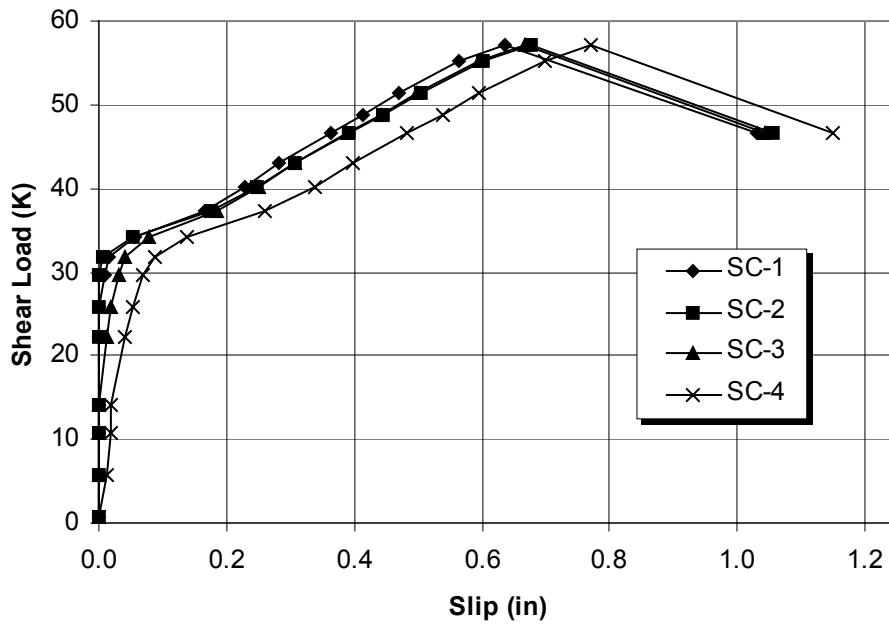

Test XOREX25-Screw-1: Load vs. Slip (B)

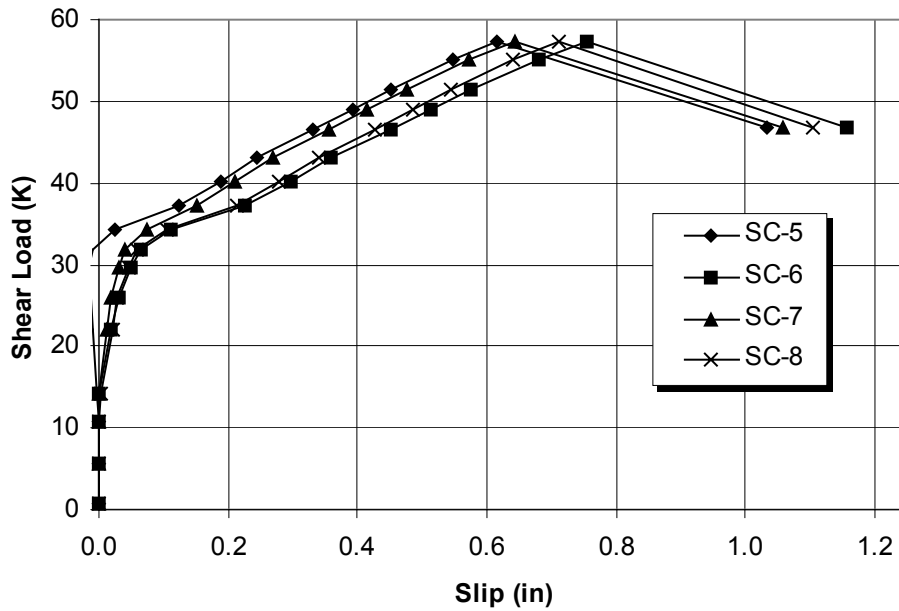

Figure G-3 XOREX25-Screw-1 Applied Shear Load vs. Slip

PUSHOUT TEST SUMMARY SHEET

Test: XOREX-25-Screw-2

Test Date: 16-Jul-01

SPECIMEN DESCRIPTION			
Screw:	Height: <u>3.0 in.</u>	No. Per Specimen: <u>10</u>	
Deck:	Type: <u>1.5VL, 22 ga</u>	Width: <u>36 in.</u>	Length: <u>36 in.</u>
	F_y : <u>54 ksi</u>	F_u : <u>63 ksi</u>	
Base Member:	Section: <u>2L 2.00x2.00x0.187</u>		
	F_y : <u>69 ksi</u>	F_u : <u>88.5 ksi</u>	
Slab:	Thickness: <u>3.50 in.</u>	f'_c : <u>3600 psi</u>	
Rebar:	Size: <u>No. 4</u>	No. Per Specimen: <u>8</u>	
		Height Above Deck: <u>0.75 in.</u>	
Mesh:	Type: <u>WWF 6x6-W2.9xW2.9</u>		

TEST RESULTS			
Peak Shear Load: <u>55.46 kips</u>			
Peak Shear Load Per Screw: <u>5.546 kips</u>			
Slip at Peak Shear Load :	SC1: <u>0.810 in.</u>	SC5: <u>0.744 in.</u>	
	SC2: <u>N/A</u>	SC6: <u>0.896 in.</u>	
	SC3: <u>0.772 in.</u>	SC7: <u>N/A</u>	
	SC4: <u>0.801 in.</u>	SC8: <u>0.867 in.</u>	

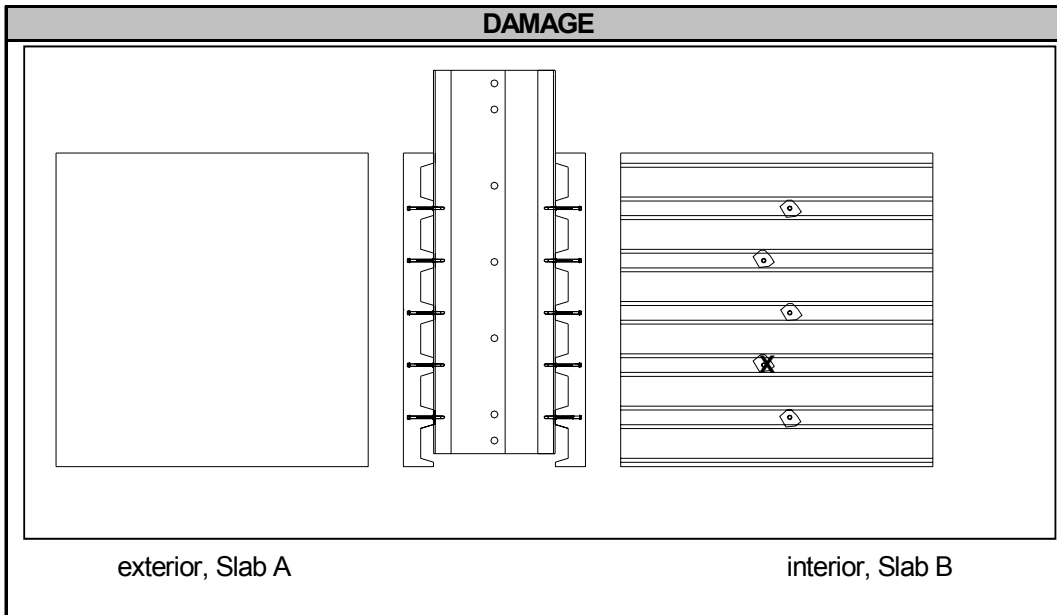

COMMENTS
Failure Mode: Screw Shear Screw Rotation $\approx 30^\circ - 40^\circ$ X = Screw sheared off

Table G-4 XOREX25-Screw-2 Test Data

TEST XOREX25-Screw-2 DATA									
Shear	Normal	Slip							
Load	Load	(in)							
(kips)	(kips)	SC-1	SC-2	SC-3	SC-4	SC-5	SC-6	SC-7	SC-8
0.20	0.00	0.000	-0.001	0.000	0.000	-0.001	0.000	N/A	0.000
6.19	1.11	0.001	0.001	0.001	-0.001	0.000	0.000	N/A	0.000
10.30	1.45	0.002	0.000	0.001	-0.002	0.001	0.000	N/A	0.004
15.51	1.60	0.002	0.006	0.001	-0.002	0.001	0.005	N/A	0.012
18.93	1.97	0.001	0.008	0.001	-0.002	0.001	0.011	N/A	0.019
22.88	2.42	0.001	0.015	0.002	-0.003	0.001	0.020	N/A	0.027
24.71	2.66	0.002	0.016	0.003	-0.002	0.001	0.024	N/A	0.032
26.30	2.81	0.002	0.019	0.002	-0.003	0.001	0.028	N/A	0.036
29.07	3.26	0.003	0.028	0.002	-0.003	0.004	0.043	N/A	0.049
32.00	3.56	0.017	0.047	0.003	-0.003	0.019	0.066	N/A	0.072
34.20	3.76	0.066	0.106	0.028	0.034	0.066	0.129	N/A	0.132
37.42	4.12	0.159	0.208	0.116	0.133	0.151	0.236	N/A	0.235
40.23	4.59	0.237	0.285	0.186	0.214	0.215	0.316	N/A	0.312
43.32	4.89	0.324	0.376	0.271	0.310	0.299	0.411	N/A	0.402
46.34	5.09	0.399	0.468	0.345	0.386	0.367	0.483	N/A	0.473
49.35	5.45	0.476	0.538	0.422	0.466	0.433	0.552	N/A	0.539
51.18	5.89	0.533	0.591	0.483	0.526	0.486	0.609	N/A	0.594
54.36	6.20	0.642	0.711	0.601	0.640	0.589	0.725	N/A	0.702
55.46	6.42	0.810	N/A	0.772	0.801	0.744	0.896	N/A	0.867
41.49	6.47	1.2815	N/A	1.2668	1.2529	1.1134	1.2700	N/A	1.2221

Test XOREX25-Screw-2: Load vs. Slip (B)

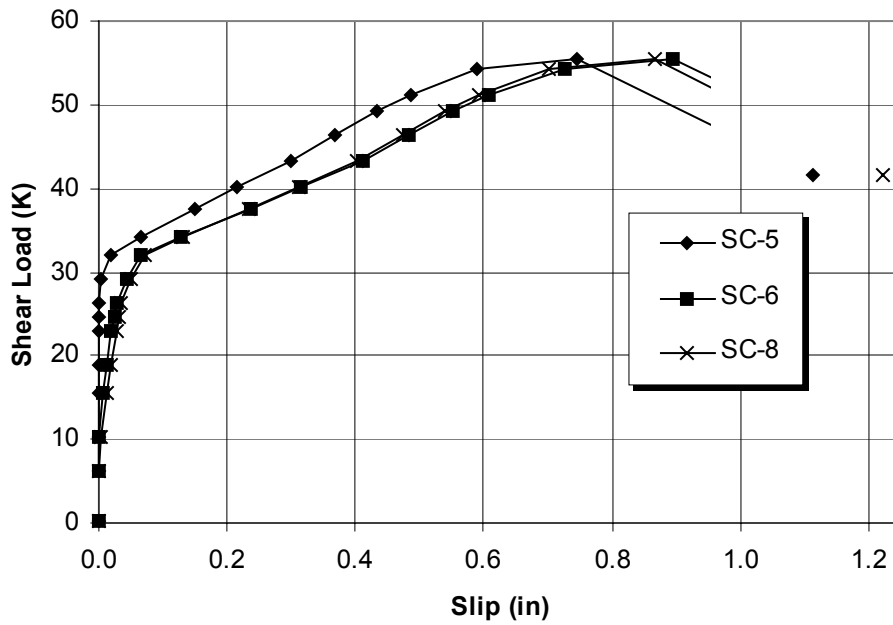

Test XOREX25-Screw-2: Load vs. Slip (A)

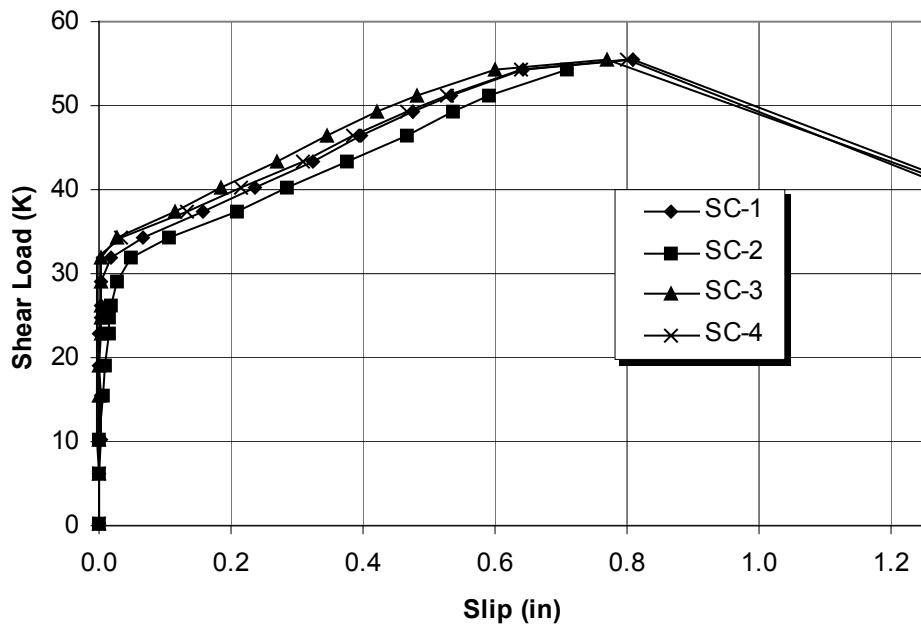

Figure G-4 XOREX25-Screw-2 Applied Shear Load vs. Slip

PUSHOUT TEST SUMMARY SHEET

Test: XOREX25-WSTUDS-1

Test Date: 30-Aug-01

SPECIMEN DESCRIPTION			
Stud:	3/4" dia x 4 3/8" Long	No. Per Specimen: <u>4</u>	
Deck:	Type: <u>2.0VL, 20 ga</u>	Width: <u>36 in.</u>	Length: <u>36 in.</u>
	F _y : <u>48 ksi</u>	F _u : <u>51 ksi</u>	
Base Member:	Section: <u>2L-4.00x0.500</u>		
	F _y : <u>54 ksi</u>	F _u : <u>79 ksi</u>	
Slab:	Thickness: <u>6.00 in.</u>	f' _c : <u>3600 psi</u>	
Rebar:	Size: <u>No. 4</u>	No. Per Specimen: <u>6</u>	
		Height Above Deck: <u>1.00 in.</u>	
Mesh:	Type: <u>25 lb/cyd -1.5" XOREX Steel Fibers</u>		

TEST RESULTS			
Peak Shear Load: <u>48.94 kips</u>			
Peak Shear Load Per Stud: <u>12.24 kips</u>			
Slip at Peak Shear Load:	SC1: <u>0.1410 in.</u>	SC5: <u>0.6520 in.</u>	
	SC2: <u>0.1230 in.</u>	SC6: <u>0.5690 in.</u>	
	SC3: <u>0.1820 in.</u>	SC7: <u>0.6560 in.</u>	
	SC4: <u>0.1120 in.</u>	SC8: <u>0.6050 in.</u>	

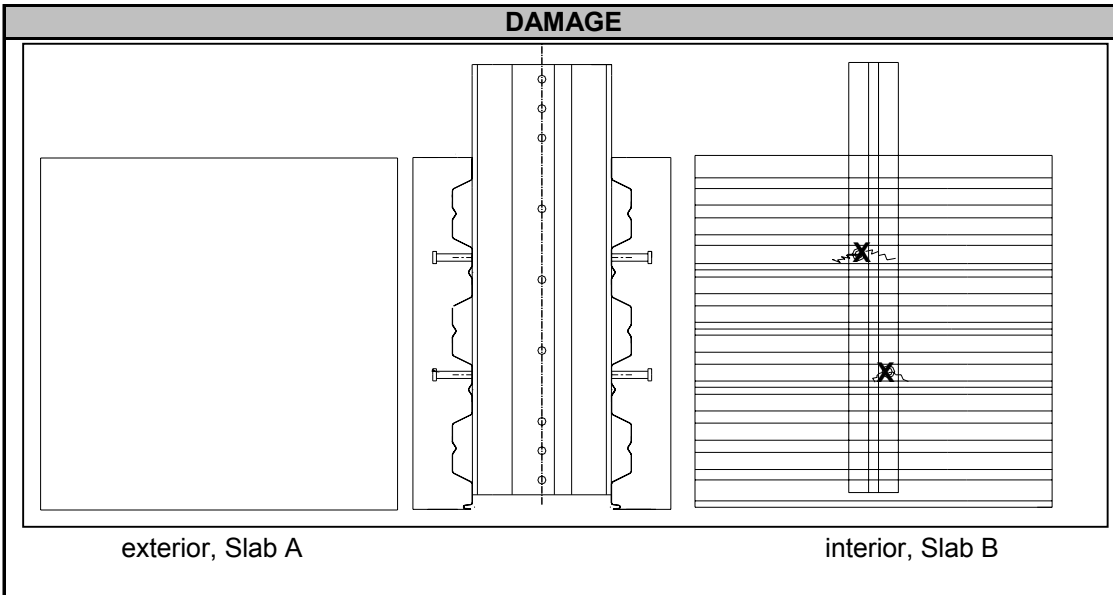

COMMENTS
Failure Mode: Studs Rib Failure Debonding X = Stud sheared off

Table G-5 XOREX25-Weak Stud-1 Test Data

TEST XOREX25-Weak Stud-1 DATA									
Shear	Normal	Slip							
Load	Load	(in)							
(kips)	(kips)	SC-1	SC-2	SC-3	SC-4	SC-5	SC-6	SC-7	SC-8
0.00	0.00	0.000	0.000	-0.001	-0.001	-0.001	0.000	0.000	-0.001
5.09	0.64	0.000	-0.001	0.000	-0.002	-0.001	-0.001	-0.002	-0.002
11.28	1.26	0.000	-0.001	0.000	-0.003	-0.001	-0.001	-0.001	-0.001
14.05	1.46	0.000	-0.002	0.001	-0.002	0.001	0.000	0.004	-0.001
19.22	1.93	-0.001	-0.001	0.005	-0.003	0.007	-0.001	0.008	-0.001
24.55	2.39	-0.001	0.001	0.008	-0.002	0.015	-0.001	0.017	0.001
27.97	2.72	-0.001	0.003	0.013	-0.002	0.021	-0.001	0.024	0.004
31.31	2.92	0.000	0.005	0.018	0.002	0.025	-0.001	0.027	0.006
33.06	3.36	0.000	0.007	0.021	0.002	0.028	-0.001	0.031	0.008
36.44	3.97	0.000	0.011	0.028	0.005	0.040	-0.001	0.044	0.016
40.31	4.39	0.005	0.020	0.042	0.014	0.059	-0.001	0.065	0.032
42.79	4.72	0.014	0.027	0.053	0.020	0.075	0.009	0.079	0.045
45.03	4.77	0.027	0.037	0.070	0.029	0.098	0.025	0.101	0.064
47.39	5.28	0.087	0.081	0.129	0.071	0.200	0.110	0.205	0.155
48.94	4.91	0.141	0.123	0.182	0.112	0.652	0.569	0.656	0.605
26.18	6.36	1.0423	0.9105	1.0858	0.8945	1.6370	1.6575	1.6100	1.6791

Test XOREX25-Weak Stud-1: Load vs. Slip (A)

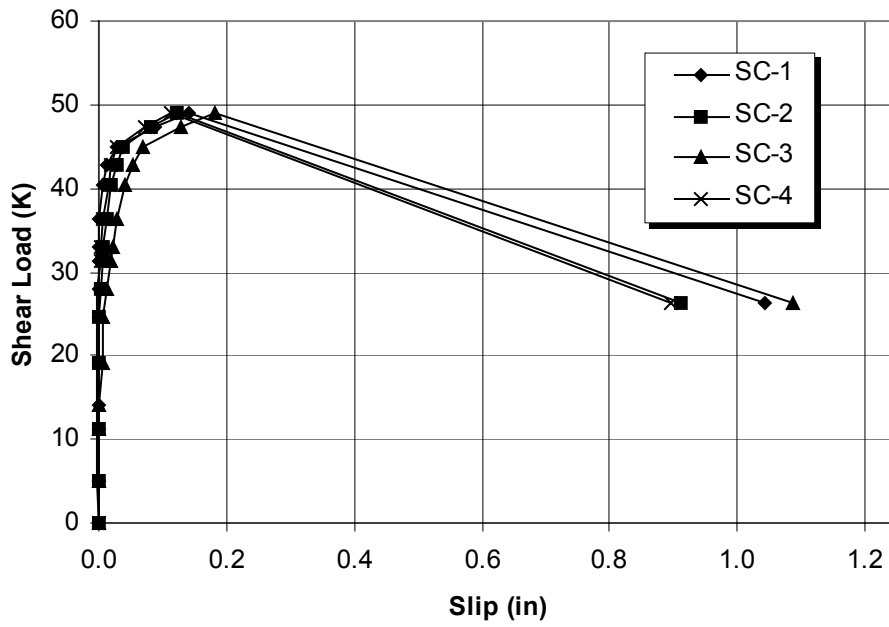

Test XOREX25-Weak Stud-1: Load vs. Slip (B)

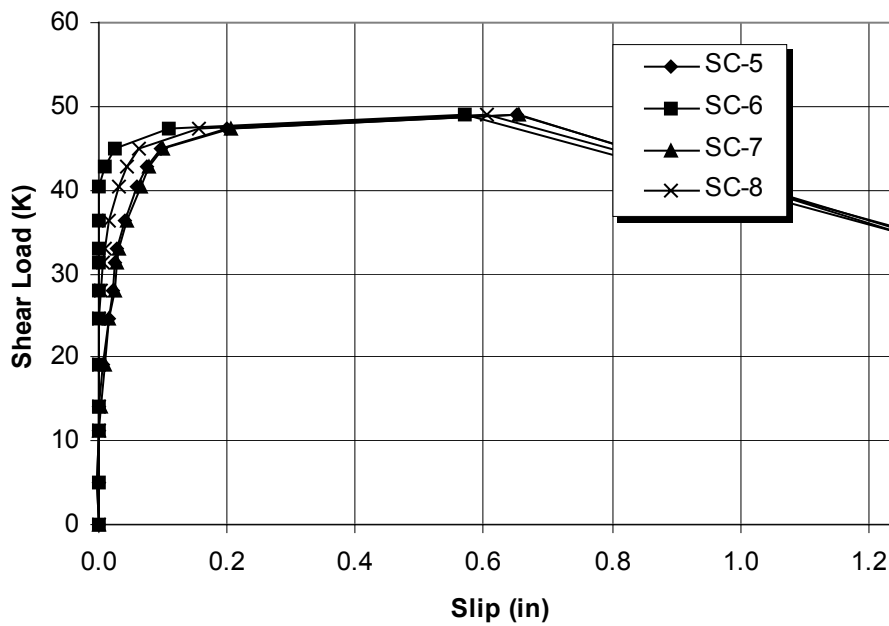

Figure G-5: XOREX25-Weak Stud-1 Applied Shear Load vs. Slip

PUSHOUT TEST SUMMARY SHEET

Test: XOREX25-WSTUDS-2

Test Date: 31-Aug-01

SPECIMEN DESCRIPTION			
Stud:	3/4" dia x 4 3/8" Long	No. Per Specimen: <u>4</u>	
Deck:	Type: <u>2.0VL, 20 ga</u>	Width: <u>36 in.</u>	Length: <u>36 in.</u>
	F _y : <u>48 ksi</u>	F _u : <u>51 ksi</u>	
Base Member:	Section: <u>2L-4.00x0.500</u>		
	F _y : <u>54 ksi</u>	F _u : <u>79 ksi</u>	
Slab:	Thickness: <u>6.00 in.</u>	f _c : <u>3600 psi</u>	
Rebar:	Size: <u>No. 4</u>	No. Per Specimen: <u>6</u>	
		Height Above Deck: <u>1.00 in.</u>	
Mesh:	Type: <u>25 lb/cyd -1.5" XOREX Steel Fibers</u>		

TEST RESULTS			
Peak Shear Load: <u>53.46 kips</u>			
Peak Shear Load Per Stud: <u>13.37 kips</u>			
Slip at Peak Shear Load:	SC1: <u>0.1140 in.</u>	SC5: <u>0.3350 in.</u>	
	SC2: <u>0.0770 in.</u>	SC6: <u>0.3190 in.</u>	
	SC3: <u>N/A</u>	SC7: <u>0.3340 in.</u>	
	SC4: <u>0.0400 in.</u>	SC8: <u>0.2940 in.</u>	

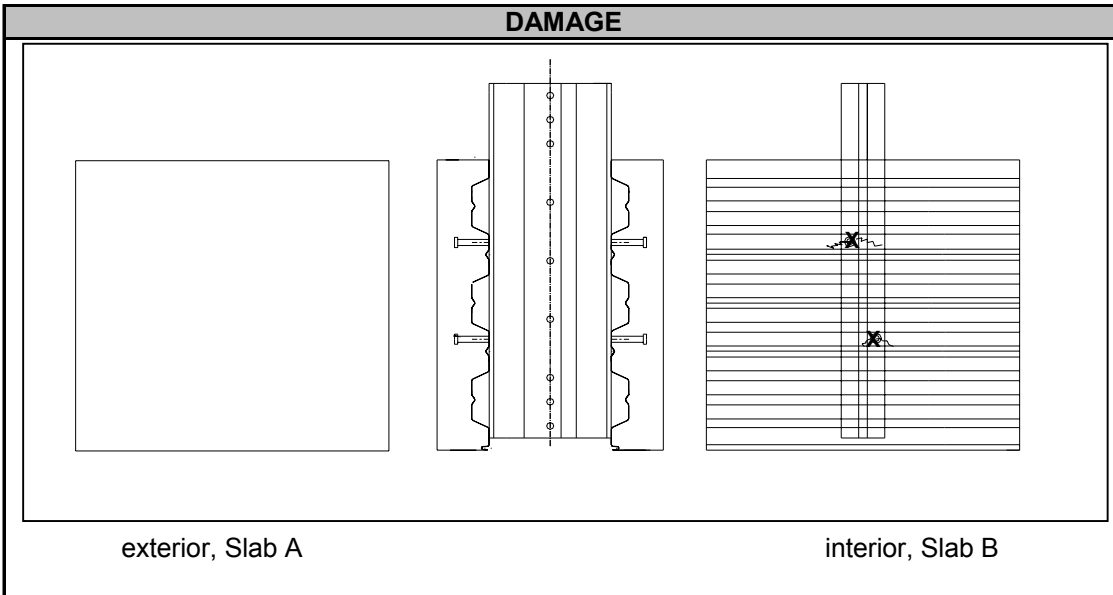

COMMENTS
Failure Mode: Studs Rib Failure Debonding X = Screw sheared off

Table G-6: XOREX25-Weak Stud-2 Test Data

Shear	Normal	Slip							
Load	Load	(in)							
(kips)	(kips)	SC-1	SC-2	SC-3	SC-4	SC-5	SC-6	SC-7	SC-8
0.00	0.00	-0.001	0.000	0.000	0.000	0.000	0.000	0.000	0.000
5.82	0.98	-0.001	0.000	-0.001	0.000	0.000	0.002	0.001	0.000
10.30	1.08	0.000	0.000	-0.001	0.000	0.003	0.002	0.001	0.000
17.18	1.51	-0.001	0.001	0.000	0.000	0.009	0.010	0.007	0.000
20.36	2.01	0.000	0.001	0.000	0.000	0.013	0.014	0.008	0.000
24.76	2.42	0.000	0.001	0.003	0.000	0.018	0.019	0.015	0.004
27.61	2.80	0.000	0.002	0.002	0.000	0.020	0.021	0.018	0.007
30.90	3.25	0.003	0.001	0.001	0.001	0.025	0.026	0.022	0.008
33.63	3.40	0.005	0.001	0.001	0.001	0.030	0.029	0.027	0.014
35.99	3.67	0.008	0.001	0.001	0.001	0.035	0.034	0.033	0.019
35.99	3.67	0.007	0.001	0.001	0.000	0.035	0.034	0.033	0.018
38.31	4.00	0.012	0.001	0.001	0.001	0.042	0.040	0.040	0.025
44.30	4.44	0.025	0.001	0.001	0.001	0.065	0.063	0.065	0.044
45.93	4.86	0.032	0.001	0.002	0.001	0.077	0.074	0.077	0.056
50.45	5.32	0.053	0.015	-0.001	0.001	0.115	0.108	0.116	0.086
51.55	5.59	0.075	0.038	-0.005	0.008	0.222	0.209	0.220	0.186
53.46	5.99	0.114	0.077	-0.007	0.040	0.335	0.319	0.334	0.294
50.29	6.03	0.9471	0.9786	0.8049	0.9490	1.3594	1.2598	1.3632	1.2434

Test XOREX25-Weak Stud-2: Load vs. Slip (A)

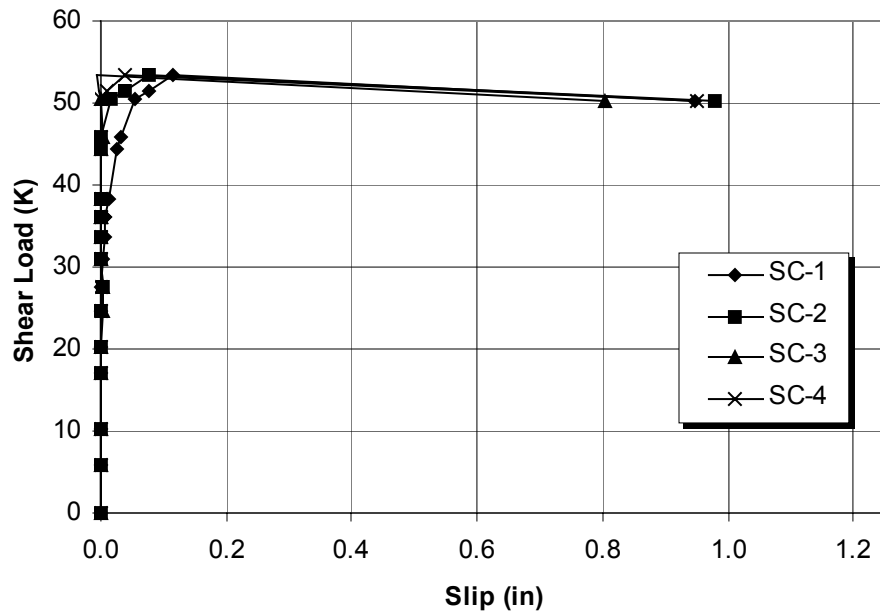

Test XOREX25-Weak Stud-2: Load vs. Slip (B)

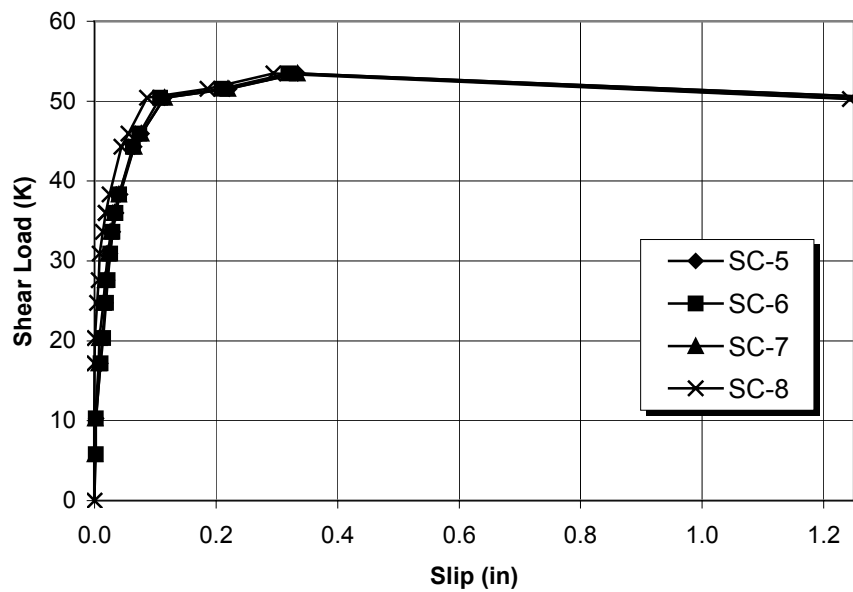

Figure G-6: XOREX25-Weak Stud-2 Applied Shear Load vs. Slip

PUSHOUT TEST SUMMARY SHEET

Test: XOREX50-Screw-1

Test Date: 13-Aug-01

SPECIMEN DESCRIPTION			
Screw:	Height: <u>3.0 in.</u>	No. Per Specimen: <u>10</u>	
Deck:	Type: <u>1.5VL, 22 ga</u>	Width: <u>36 in.</u>	Length: <u>36 in.</u>
	F _y : <u>54 ksi</u>	F _u : <u>63 ksi</u>	
Base Member:	Section: <u>2L 2.00x2.00x0.187</u>		
	F _y : <u>69 ksi</u>	F _u : <u>88.5 ksi</u>	
Slab:	Thickness: <u>3.50 in.</u>	f' _c : <u>3600 psi</u>	
Rebar:	Size: <u>No. 4</u>	No. Per Specimen: <u>8</u>	
		Height Above Deck: <u>0.75 in.</u>	
Mesh:	Type: <u>50 lb/cyd -1.5" XOREX Steel Fibers</u>		

TEST RESULTS			
Peak Shear Load: <u>49.43 kips</u>			
Peak Shear Load Per Screw: <u>4.943 kips</u>			
Slip at Peak Shear Load:	SC1: <u>0.920 in.</u>	SC5: <u>0.619 in.</u>	
	SC2: <u>0.963 in.</u>	SC6: <u>0.669 in.</u>	
	SC3: <u>0.925 in.</u>	SC7: <u>0.606 in.</u>	
	SC4: <u>0.965 in.</u>	SC8: <u>0.647 in.</u>	

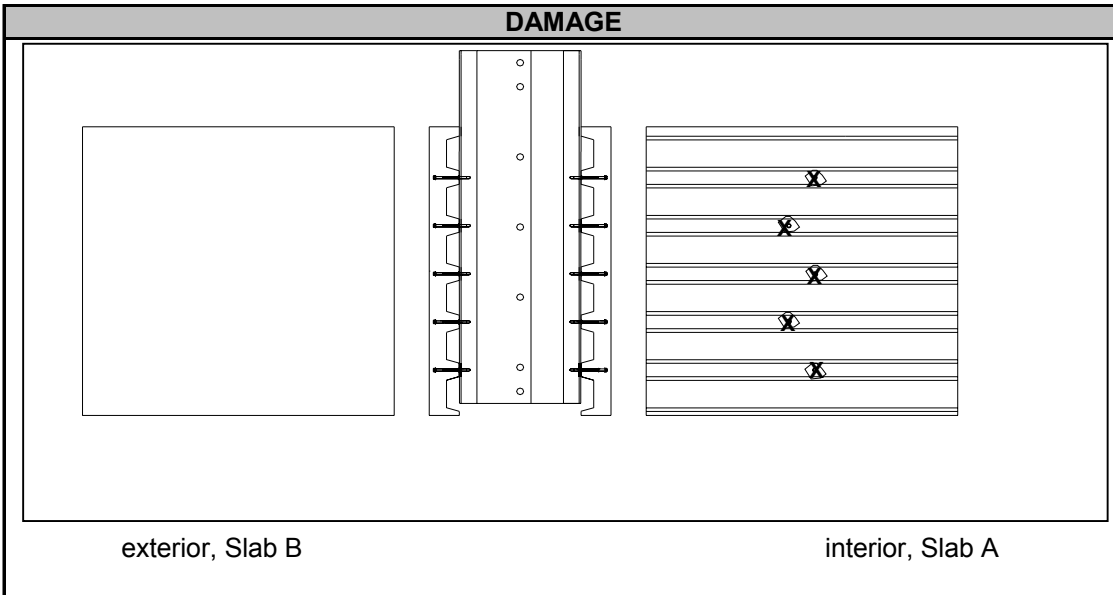

COMMENTS
<p>Failure Mode: Screw Shear Screw Rotation ≈ 30° - 40° X = Screw sheared off</p>

Table G-7: XOREX50-Screw-1 Test Data

TEST XOREX50-Screw-1 DATA									
Shear	Normal	Slip							
Load	Load	(in)							
(kips)	(kips)	SC-1	SC-2	SC-3	SC-4	SC-5	SC-6	SC-7	SC-8
-0.08	0.00	0.000	0.000	-0.001	0.000	-0.001	-0.001	0.000	0.000
5.86	1.39	0.000	0.000	0.000	0.001	0.000	0.000	0.000	0.000
11.40	1.34	0.000	0.000	0.001	0.003	0.000	0.002	0.000	0.000
15.47	1.49	0.000	0.001	0.001	0.005	0.002	0.005	0.001	0.000
19.26	1.92	0.000	0.007	0.005	0.012	0.007	0.010	0.005	0.001
23.17	2.66	0.007	0.021	0.019	0.029	0.018	0.021	0.017	0.007
26.34	3.17	0.016	0.035	0.030	0.043	0.026	0.029	0.024	0.016
28.83	3.13	0.041	0.062	0.055	0.071	0.044	0.051	0.042	0.040
29.97	3.41	0.084	0.106	0.096	0.119	0.065	0.075	0.061	0.064
32.78	3.74	0.207	0.237	0.219	0.247	0.180	0.198	0.173	0.185
35.42	4.00	0.322	0.355	0.334	0.365	0.281	0.309	0.274	0.298
38.44	4.37	0.422	0.457	0.436	0.467	0.365	0.399	0.358	0.385
40.31	4.94	0.482	0.516	0.494	0.526	0.404	0.440	0.396	0.426
42.39	4.98	0.556	0.593	0.570	0.601	0.445	0.485	0.434	0.469
45.15	5.44	0.777	0.819	0.785	0.824	0.519	0.563	0.503	0.544
48.05	5.22	0.876	0.918	0.882	0.923	0.589	0.637	0.576	0.616
49.43	5.69	0.920	0.963	0.925	0.965	0.619	0.669	0.606	0.647
45.89	5.94	1.322	1.379	1.157	1.374	0.799	0.830	0.797	0.825
45.81	5.58	1.408	1.471	1.157	1.466	0.917	0.894	0.911	0.941

Test XOREX50-Screw-1: Load vs. Slip (A)

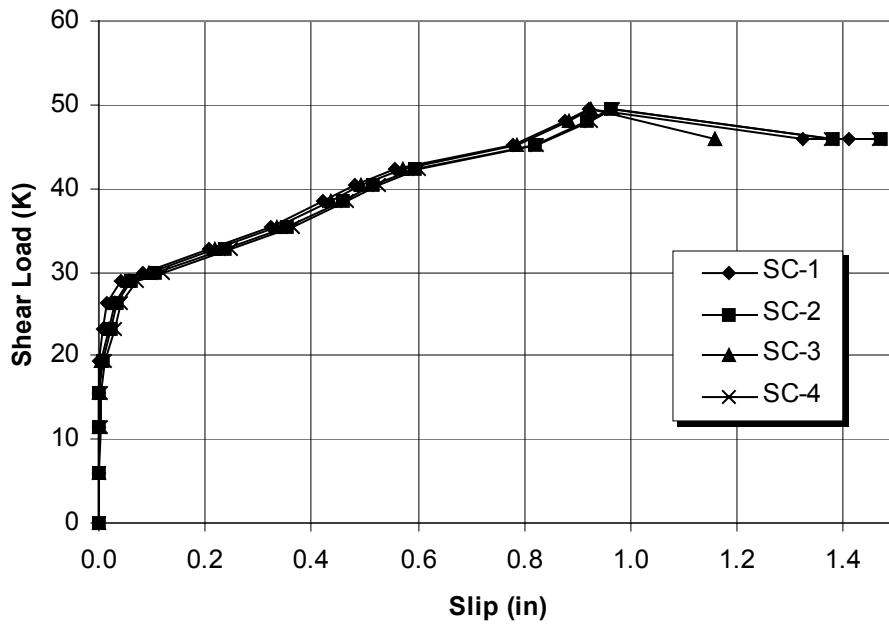

Test XOREX50-Screw-1: Load vs. Slip (B)

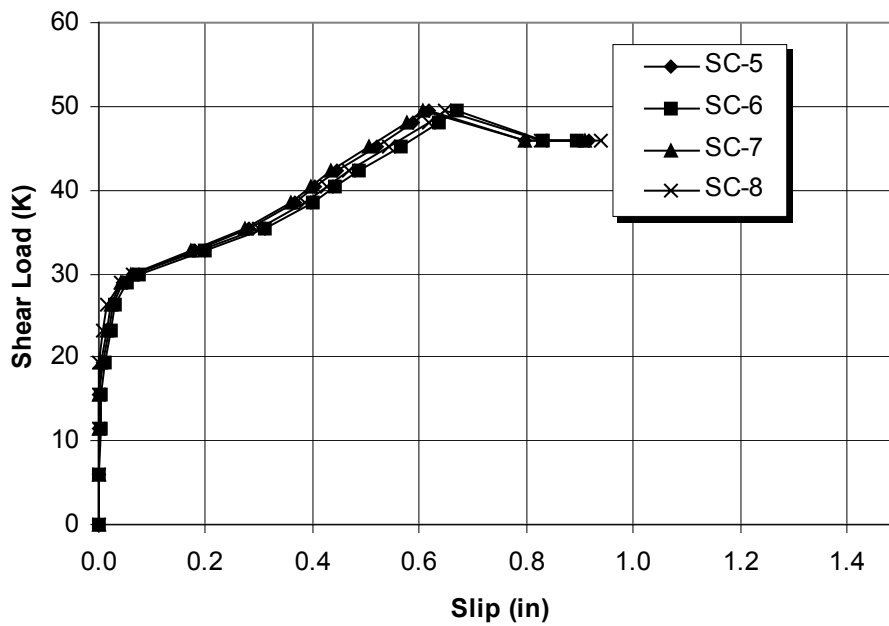

Figure G-7: XOREX50-Screw-1 Applied Shear Load vs. Slip

PUSHOUT TEST SUMMARY SHEET

Test: XOREX50-Screw-2

Test Date: 27-Aug-01

SPECIMEN DESCRIPTION			
Screw:	Height: <u>3.0 in.</u>	No. Per Specimen: <u>10</u>	
Deck:	Type: <u>1.5VL, 22 ga</u>	Width: <u>36 in.</u>	Length: <u>36 in.</u>
	F _y : <u>54 ksi</u>	F _u : <u>63 ksi</u>	
Base Member:	Section: <u>2L 2.00x2.00x0.187</u>		
	F _y : <u>69 ksi</u>	F _u : <u>88.5 ksi</u>	
Slab:	Thickness: <u>3.50 in.</u>	f' _c : <u>4200 psi</u>	
Rebar:	Size: <u>No. 4</u>	No. Per Specimen: <u>8</u>	
		Height Above Deck: <u>0.75 in.</u>	
Mesh:	Type: <u>50 lb/cyd -1.5" XOREX Steel Fibers</u>		

TEST RESULTS		
Peak Shear Load: <u>52.36 kips</u>		
Peak Shear Load Per Screw: <u>5.236 kips</u>		
Slip at Peak Shear Load:	SC1: <u>N/A</u>	SC5: <u>0.7270 in.</u>
	SC2: <u>0.8146 in.</u>	SC6: <u>0.6110 in.</u>
	SC3: <u>N/A</u>	SC7: <u>N/A</u>
	SC4: <u>0.8359 in.</u>	SC8: <u>0.5842 in.</u>

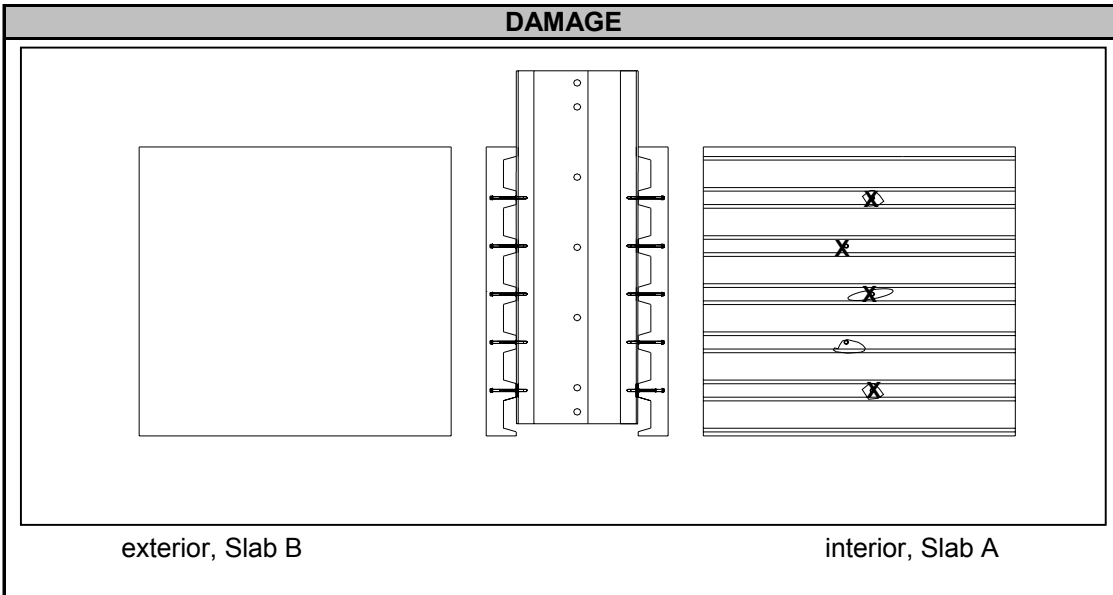

COMMENTS
Failure Mode: Screw Shear Screw Rotation $\approx 30^\circ - 40^\circ$ X = Screw sheared off

Table G-8: XOREX50-Screw-2 Test Data

Shear Load (kips)	Normal Load (kips)	Slip (in)							
		SC-1	SC-2	SC-3	SC-4	SC-5	SC-6	SC-7	SC-8
0.00	0.00	-0.001	0.000	0.000	0.000	-0.001	-0.001	0.000	0.000
5.74	0.97	-0.001	0.000	0.000	0.003	0.000	0.000	0.001	0.000
10.63	1.23	-0.001	0.000	0.000	0.003	-0.001	0.000	0.001	0.000
15.23	1.42	0.000	0.002	0.000	0.006	0.000	0.000	0.004	-0.001
17.10	1.82	0.000	0.004	0.000	0.008	0.000	0.000	0.005	-0.001
20.89	2.14	0.000	0.010	0.000	0.016	0.000	0.000	0.010	0.004
23.62	2.64	-0.001	0.014	0.001	0.022	0.000	0.000	0.013	0.007
26.06	2.94	0.000	0.021	0.000	0.031	0.000	0.001	0.017	0.011
26.02	2.94	0.000	0.021	0.000	0.030	0.000	0.000	0.018	0.011
28.38	3.12	0.000	0.029	0.001	0.040	0.003	0.000	0.023	0.016
31.35	3.47	0.000	0.045	0.002	0.057	0.014	0.000	0.035	0.029
33.14	3.90	0.000	0.059	0.002	0.073	0.024	0.001	0.047	0.041
34.93	4.12	0.000	0.086	0.002	0.101	0.047	0.001	0.071	0.066
37.74	4.36	0.000	0.246	0.017	0.267	0.199	0.094	0.209	0.222
40.35	4.64	0.010	0.337	0.051	0.360	0.288	0.184	0.295	0.315
42.96	4.86	0.057	0.392	0.077	0.416	0.341	0.238	0.339	0.368
45.89	5.11	0.140	0.491	0.134	0.516	0.433	0.329	0.429	0.465
48.78	5.79	0.208	0.577	0.186	0.602	0.513	0.406	0.495	0.527
50.57	6.35	0.291	0.672	0.234	0.695	0.601	0.491	0.597	0.557
52.36	6.05		0.8146		0.8359	0.7270	0.6110		0.5842
26.14	7.13		1.6144		1.7273	1.0161	0.8628		0.5992

Test XOREX50-Screw-2: Load vs. Slip (A)

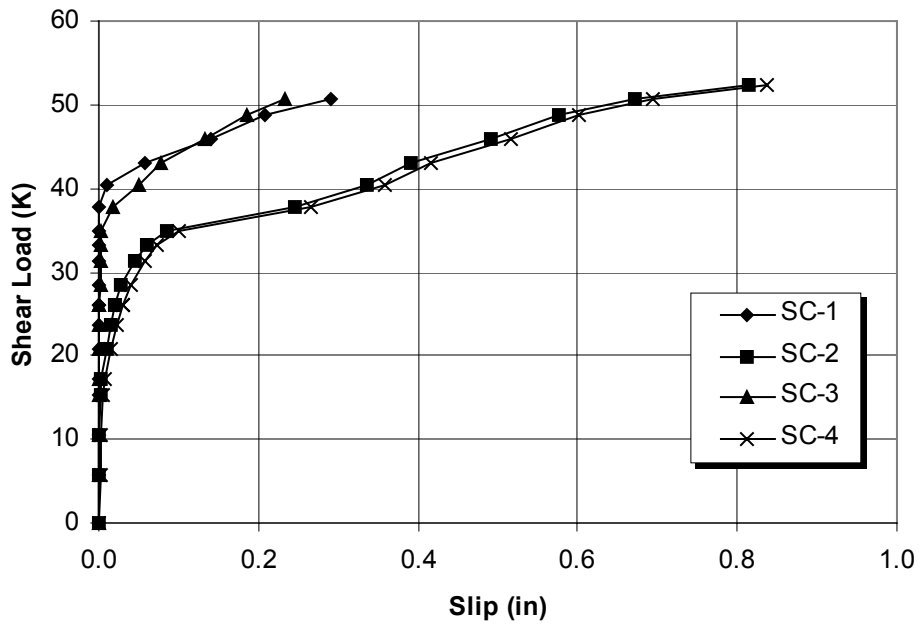

Test XOREX50-Screw-2: Load vs. Slip (B)

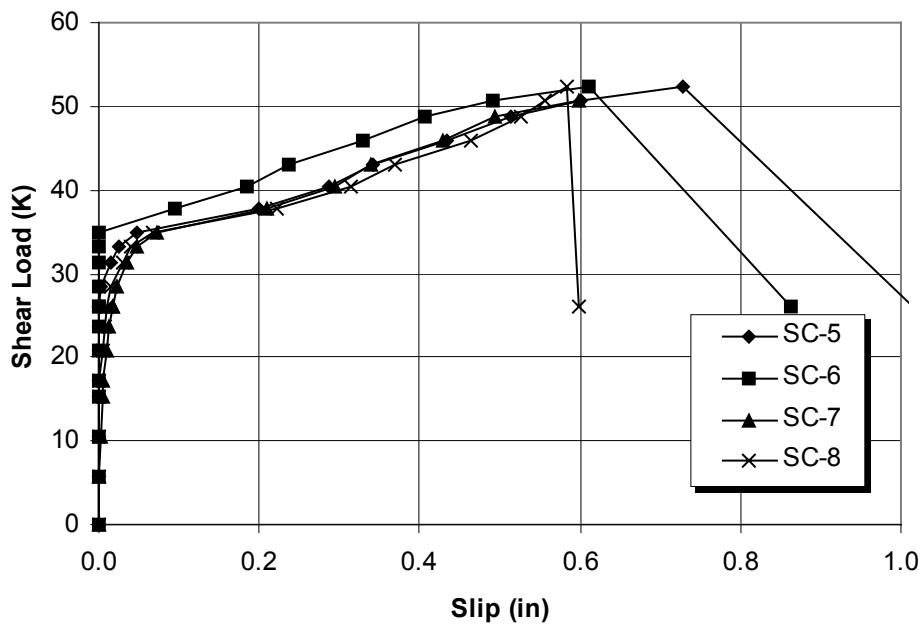

Figure G-8: XOREX50-Screw-2 Applied Shear Load vs. Slip

PUSHOUT TEST SUMMARY SHEET

Test: XOREX50-WSTUDS-1

Test Date: 3-Sep-01

SPECIMEN DESCRIPTION			
Stud:	3/4" dia x 4 3/8" Long	No. Per Specimen: <u>4</u>	
Deck:	Type: <u>2.0VL, 20 ga</u>	Width: <u>36 in.</u>	Length: <u>36 in.</u>
	F _y : <u>48 ksi</u>	F _u : <u>51 ksi</u>	
Base Member:	Section: <u>2L-4.00x0.500</u>		
	F _y : <u>54 ksi</u>	F _u : <u>79 ksi</u>	
Slab:	Thickness: <u>6.00 in.</u>	f' _c : <u>4200 psi</u>	
Rebar:	Size: <u>No. 4</u>	No. Per Specimen: <u>6</u>	
		Height Above Deck: <u>1.00 in.</u>	
Mesh:	Type: <u>50 lb/cyd -1.5" XOREX Steel Fibers</u>		

TEST RESULTS			
Peak Shear Load: <u>51.06 kips</u>			
Peak Shear Load Per Stud: <u>12.77 kips</u>			
Slip at Peak Shear Load:	SC1: <u>0.149 in.</u>	SC5: <u>0.085 in.</u>	
	SC2: <u>0.152 in.</u>	SC6: <u>N/A</u>	
	SC3: <u>0.160 in.</u>	SC7: <u>0.094 in.</u>	
	SC4: <u>0.140 in.</u>	SC8: <u>0.063 in.</u>	

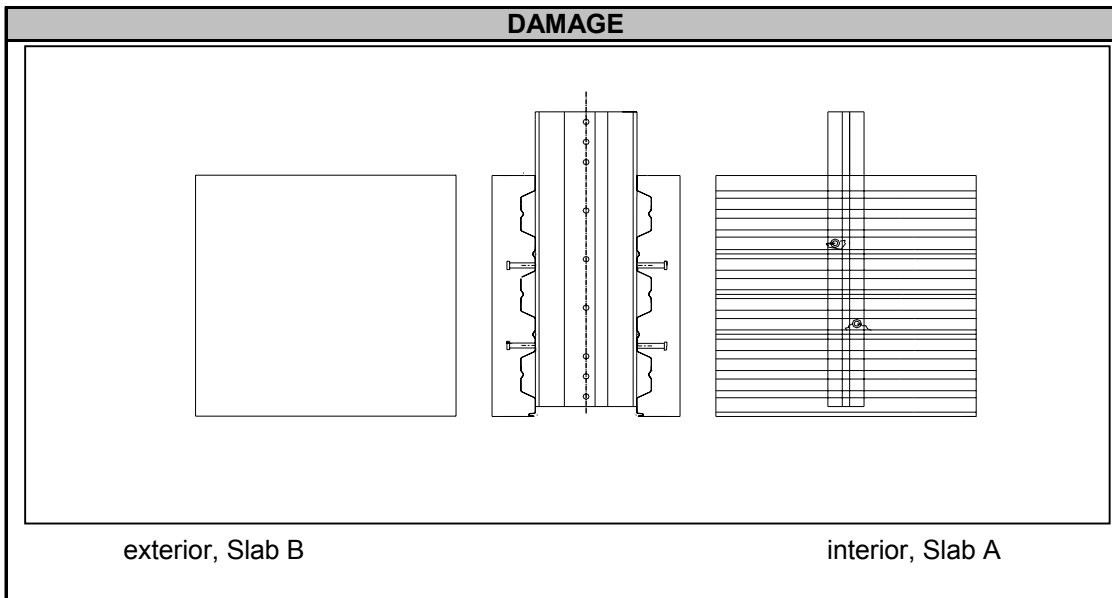

COMMENTS
Failure Mode: Debonding X = Studs sheared off

Table G-9: XOREX50-Weak Stud-1 Test Data

Shear Load (kips)	Normal Load (kips)	Slip (in)							
		SC-1	SC-2	SC-3	SC-4	SC-5	SC-6	SC-7	SC-8
-0.08	0.01	-0.001	0.000	0.000	0.000	0.000	0.000	-0.001	-0.001
4.80	0.87	0.001	0.003	0.001	0.000	0.002	0.000	0.008	0.000
10.46	1.15	0.000	0.004	0.002	0.000	0.002	0.000	0.008	0.000
15.11	1.43	0.001	0.007	0.006	0.001	0.004	0.000	0.008	0.001
19.83	1.87	0.009	0.013	0.012	0.004	0.004	0.000	0.008	0.001
23.86	2.43	0.015	0.019	0.019	0.007	0.007	0.000	0.012	0.000
27.52	3.03	0.022	0.026	0.027	0.012	0.007	0.000	0.015	0.001
30.21	3.04	0.031	0.037	0.034	0.019	0.010	0.000	0.015	0.001
32.90	3.30	0.038	0.046	0.042	0.025	0.011	0.000	0.021	0.001
36.48	3.67	0.050	0.060	0.058	0.039	0.018	0.000	0.029	0.002
40.88	4.16	0.067	0.079	0.076	0.055	0.028	0.001	0.037	0.007
43.65	4.68	0.079	0.089	0.087	0.066	0.035	0.000	0.045	0.014
46.46	5.03	0.105	0.110	0.114	0.092	0.053	0.000	0.062	0.033
51.06	5.37	0.149	0.152	0.160	0.140	0.085	0.000	0.094	0.063
47.68	4.73	0.505	0.520	0.518	0.509	0.413	0.288	0.419	0.372
46.38	4.56	0.860	0.871	0.880	0.889	0.757	0.670	0.774	0.735

Test XOREX50-Weak Stud-1: Load vs. Slip (A)

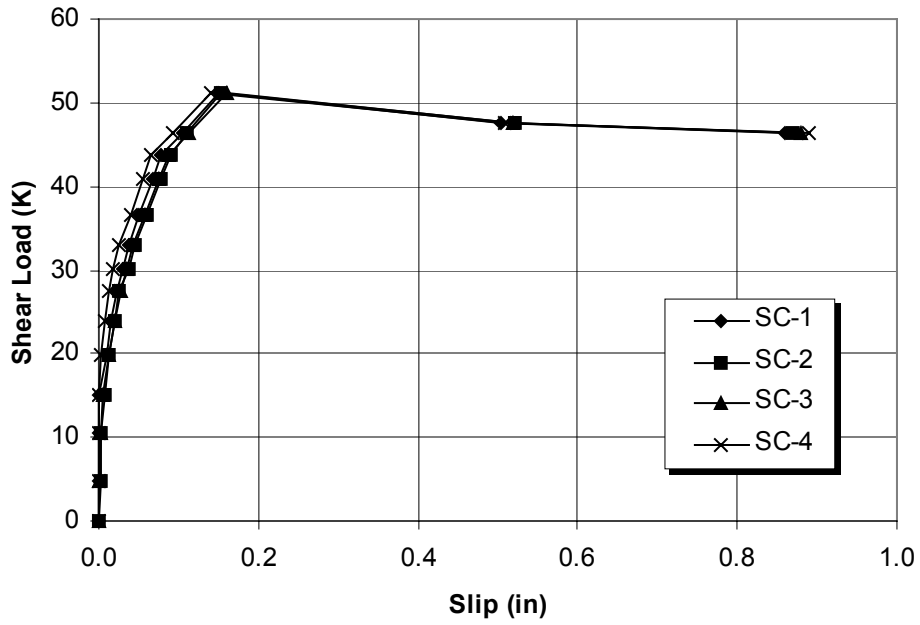

Test XOREX50-Weak Stud-1: Load vs. Slip (B)

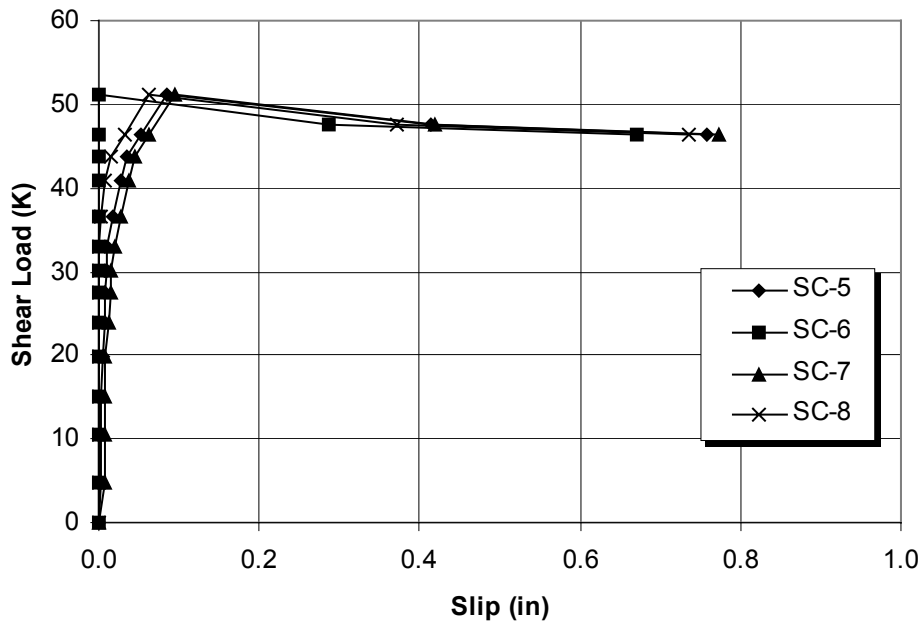

Figure G-9: XOREX50-Weak Stud-1 Applied Shear Load vs. Slip

PUSHOUT TEST SUMMARY SHEET

Test: XOREX50-Weak Stud-2

Test Date: 3-Sep-01

SPECIMEN DESCRIPTION			
Stud	3/4" dia x 4 3/8" Long	No. Per Specimen: <u>4</u>	
Deck:	Type: <u>2VLI, 20_ga</u>	Width: <u>36 in.</u>	Length: <u>36 in.</u>
	F _y : <u>48 ksi</u>	F _u : <u>51 ksi</u>	
Base Member:	Section: <u>2L 4.00x0.500</u>		
	F _y : <u>54 ksi</u>	F _u : <u>79 ksi</u>	
Slab:	Thickness: <u>6.00 in.</u>	f' _c : <u>4200 psi</u>	
Rebar:	Size: <u>No. 4</u>	No. Per Specimen: <u>6</u>	
		Height Above Deck: <u>1.00 in.</u>	
Mesh:	Type: <u>50 lb/cyd -1.5" XOREX Steel Fibers</u>		

TEST RESULTS			
Peak Shear Load: <u>51.95 kips</u>			
Peak Shear Load Per Stud: <u>12.99 kips</u>			
Slip at Peak Shear Load:	SC1: <u>0.1630 in.</u>	SC5: <u>0.1870 in.</u>	
	SC2: <u>0.1230 in.</u>	SC6: <u>0.1010 in.</u>	
	SC3: <u>0.1770 in.</u>	SC7: <u>0.1910 in.</u>	
	SC4: <u>0.0880 in.</u>	SC8: <u>0.1030 in.</u>	

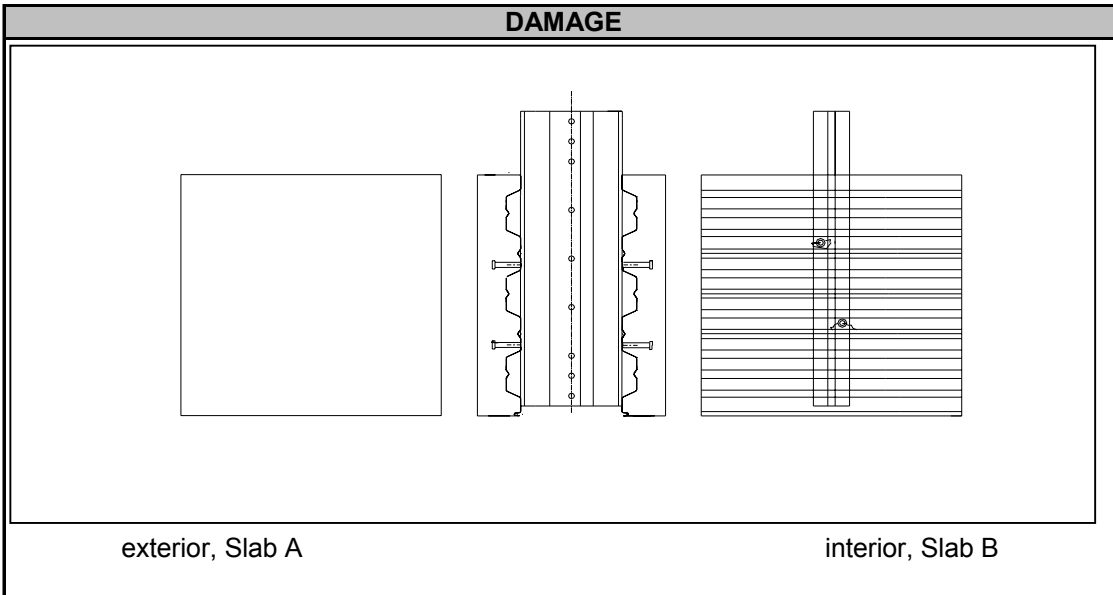

COMMENTS
Failure Mode: Screw Shear Screw Rotation ≈ 20° - 30° X = Screw sheared off

Table G-10: XOREX50-Weak Stud-2 Test Data

TEST XOREX50-Weak Stud-2 DATA									
Shear	Normal	Slip							
Load	Load	(in)							
(kips)	(kips)	SC-1	SC-2	SC-3	SC-4	SC-5	SC-6	SC-7	SC-8
-0.04	0.00	0.000	0.000	0.000	-0.001	0.000	0.000	0.000	-0.001
5.21	0.51	-0.001	0.000	0.001	0.000	0.000	0.000	0.000	-0.001
12.01	0.91	0.000	0.000	0.006	-0.001	0.003	0.000	0.004	0.000
15.23	1.47	0.001	0.001	0.007	0.000	0.005	0.001	0.008	0.000
19.67	1.91	0.004	0.001	0.012	-0.001	0.012	0.000	0.015	0.000
22.88	2.33	0.007	0.001	0.017	-0.001	0.016	0.000	0.020	0.000
25.86	2.74	0.011	0.001	0.020	-0.001	0.022	0.000	0.026	0.000
28.62	3.09	0.015	0.001	0.024	0.000	0.029	0.000	0.033	0.000
31.15	3.28	0.021	0.002	0.030	0.000	0.039	0.001	0.042	0.001
34.08	3.57	0.028	0.003	0.038	0.000	0.048	0.005	0.052	0.004
36.77	3.81	0.036	0.009	0.048	0.007	0.061	0.013	0.065	0.011
40.27	4.22	0.050	0.019	0.061	0.007	0.078	0.024	0.082	0.021
43.04	4.63	0.062	0.030	0.073	0.015	0.092	0.031	0.096	0.031
46.46	5.00	0.085	0.051	0.096	0.027	0.113	0.045	0.118	0.045
50.29	5.50	0.126	0.089	0.141	0.062	0.153	0.076	0.158	0.077
51.95	5.50	0.163	0.123	0.177	0.088	0.187	0.101	0.191	0.103
50.08	5.82	0.308	0.264	0.323	0.223	0.328	0.229	0.334	0.232

Test XOREX50-Weak Stud-2: Load vs. Slip (A)

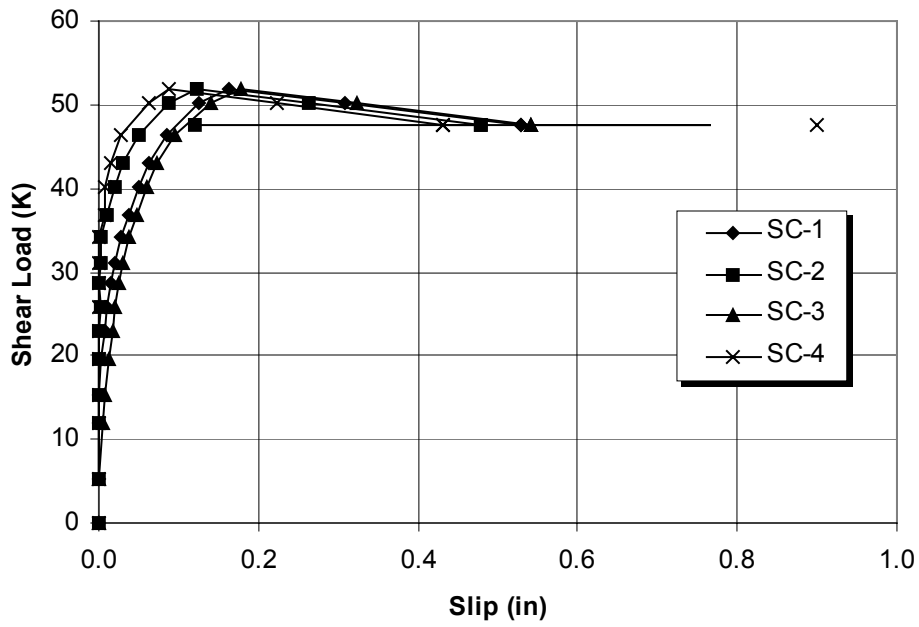

Test XOREX50-Weak Stud-2: Load vs. Slip (B)

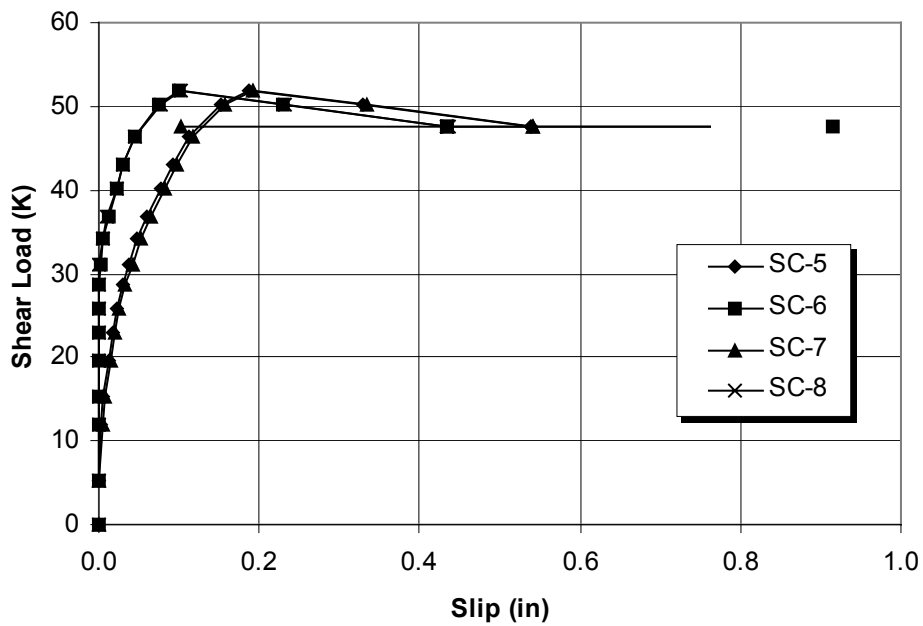

Figure G-10: XOREX50-Weak Stud-2 Applied Shear Load vs. Slip

PUSHOUT TEST SUMMARY SHEET

Test: XOREX50-SSTUDS-1

Test Date: 3-Sep-01

SPECIMEN DESCRIPTION			
Stud:	3/4" dia x 4 3/8" Long	No. Per Specimen: <u>4</u>	
Deck:	Type: <u>2.0VL, 20 ga</u>	Width: <u>36 in.</u>	Length: <u>36 in.</u>
	F _y : <u>48 ksi</u>	F _u : <u>51 ksi</u>	
Base Member:	Section: <u>2L-4.00x0.500</u>		
	F _y : <u>54 ksi</u>	F _u : <u>79 ksi</u>	
Slab:	Thickness: <u>6.00 in.</u>	f' _c : <u>4200 psi</u>	
Rebar:	Size: <u>No. 4</u>	No. Per Specimen: <u>6</u>	
		Height Above Deck: <u>1.00 in.</u>	
Mesh:	Type: <u>50 lb/cyd -1.5" XOREX Steel Fibers</u>		

TEST RESULTS			
Peak Shear Load: <u>75.29 kips</u>			
Peak Shear Load Per Stud: <u>18.82 kips</u>			
Slip at Peak Shear Load:	SC1: <u>0.2705 in.</u>	SC5: <u>0.2231 in.</u>	
	SC2: <u>0.2230 in.</u>	SC6: <u>0.1314 in.</u>	
	SC3: <u>0.2528 in.</u>	SC7: <u>0.1206 in.</u>	
	SC4: <u>0.1783 in.</u>	SC8: <u>N/A</u>	

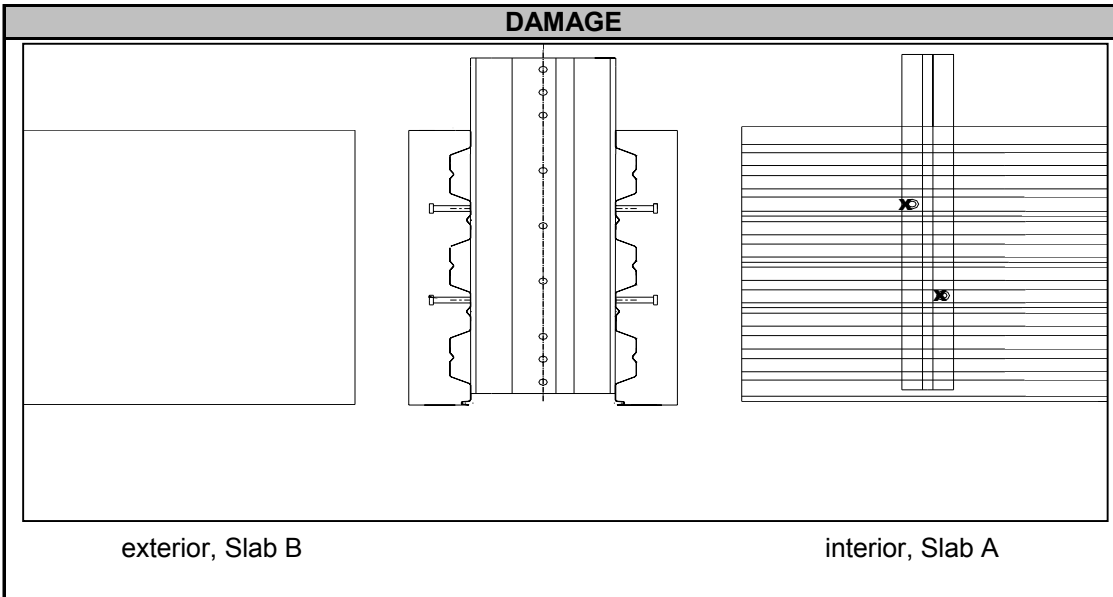

COMMENTS
Failure Mode: Some Debonding X = Studs sheared off

Table G-11: XOREX50-Strong Stud-1 Test Data

Shear	Normal	Slip							
Load	Load	(in)							
(kips)	(kips)	SC-1	SC-2	SC-3	SC-4	SC-5	SC-6	SC-7	SC-8
-0.04	0.02	-0.001	-0.001	0.000	0.000	0.000	0.000	0.000	N/A
6.43	0.67	0.000	-0.001	-0.001	0.001	0.000	0.000	0.003	N/A
10.42	1.40	0.000	0.000	-0.001	0.001	0.000	0.000	0.005	N/A
14.74	1.53	0.000	0.000	-0.001	0.001	0.002	-0.001	0.006	N/A
19.50	1.97	-0.001	0.000	-0.001	0.001	0.004	0.000	0.009	N/A
22.68	2.30	0.000	0.000	0.000	0.000	0.005	0.000	0.010	N/A
25.08	2.54	0.000	0.000	-0.001	0.000	0.007	0.000	0.014	N/A
28.30	2.81	0.000	0.000	0.000	0.000	0.007	0.000	0.015	N/A
31.27	3.34	0.000	0.000	0.000	0.000	0.010	0.000	0.017	N/A
34.28	3.51	0.000	0.000	0.000	0.000	0.012	0.000	0.020	N/A
37.26	3.84	0.001	0.000	0.000	0.000	0.014	0.000	0.023	N/A
42.02	4.54	0.001	0.002	0.001	0.000	0.019	0.000	0.029	N/A
47.39	4.94	0.007	0.004	0.001	0.001	0.026	0.000	0.036	N/A
51.10	5.40	0.011	0.007	0.001	0.000	0.029	0.000	0.041	N/A
54.07	5.77	0.021	0.012	0.007	0.001	0.035	0.000	0.046	N/A
58.88	6.30	0.040	0.023	0.023	0.001	0.046	0.000	0.055	N/A
63.88	6.87	0.057	0.034	0.039	0.004	0.055	0.000	0.064	N/A
65.47	6.82	0.071	0.041	0.051	0.007	0.064	0.000	0.072	N/A
69.14	7.47	0.097	0.063	0.080	0.028	0.085	0.009	0.091	N/A
71.50	7.68	0.1291	0.0879	0.1095	0.0542	0.1119	0.0291	0.1031	N/A
72.96	8.19	0.1771	0.1351	0.1568	0.1006	0.1504	0.0611	0.1144	N/A
75.29	9.22	0.2705	0.2230	0.2528	0.1783	0.2231	0.1314	0.1206	N/A

Test XOREX50-Strong Stud-1: Load vs. Slip (A)

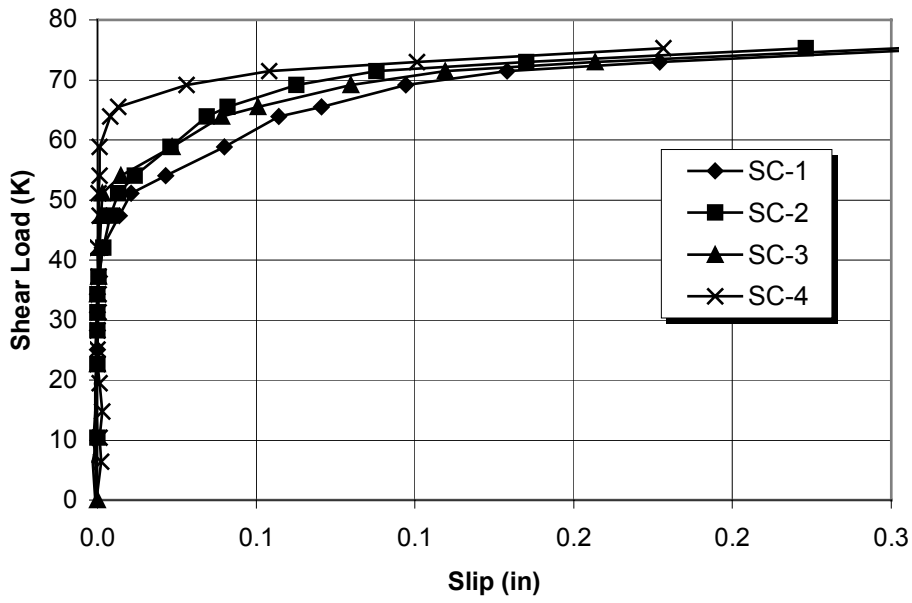

Test XOREX50-Strong Stud-1: Load vs. Slip (B)

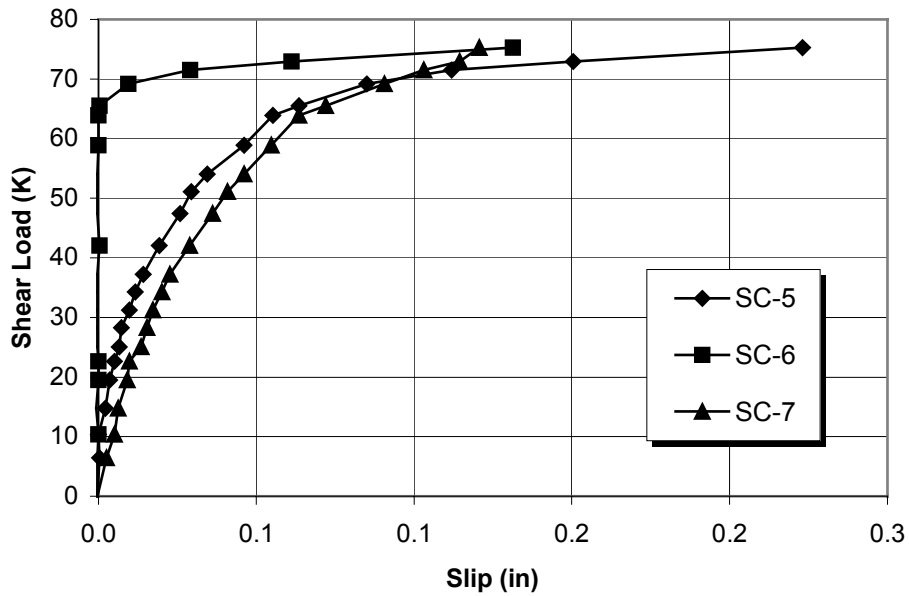

Figure G-11: XOREX50- Strong Stud-1 Applied Shear Load vs. Slip

PUSHOUT TEST SUMMARY SHEET

Test: XOREX50-SSTUDS-2
 Test Designation:

Test Date: 3-Sep-01

SPECIMEN DESCRIPTION			
Screw:	Height: <u>3.0 in.</u>	No. Per Specimen: <u>4</u>	
Deck:	Type: <u>2VL, 20 ga</u>	Width: <u>36 in.</u>	Length: <u>36 in.</u>
	F _y : <u>48 ksi</u>	F _u : <u>51 ksi</u>	
Base Member:	Section: <u>2L 4.00x0.500</u>		
	F _y : <u>54 ksi</u>	F _u : <u>79 ksi</u>	
Slab:	Thickness: <u>6.00 in.</u>	f' _c : <u>4200 psi</u>	
Rebar:	Size: <u>No. 4</u>	No. Per Specimen: <u>6</u>	
		Height Above Deck: <u>1.00 in.</u>	
Mesh:	Type: <u>50 lb/cyd -1.5" XOREX Steel Fibers</u>		

TEST RESULTS			
Peak Shear Load: <u>72.56 kips</u>			
Peak Shear Load Per Stud: <u>18.14 kips</u>			
Slip at Peak Shear Load:	SC1: <u>0.1487 in.</u>	SC5: <u>0.1668 in.</u>	
	SC2: <u>0.1190 in.</u>	SC6: <u>N/A</u>	
	SC3: <u>0.1660 in.</u>	SC7: <u>0.1163 in.</u>	
	SC4: <u>0.1190 in.</u>	SC8: <u>N/A</u>	

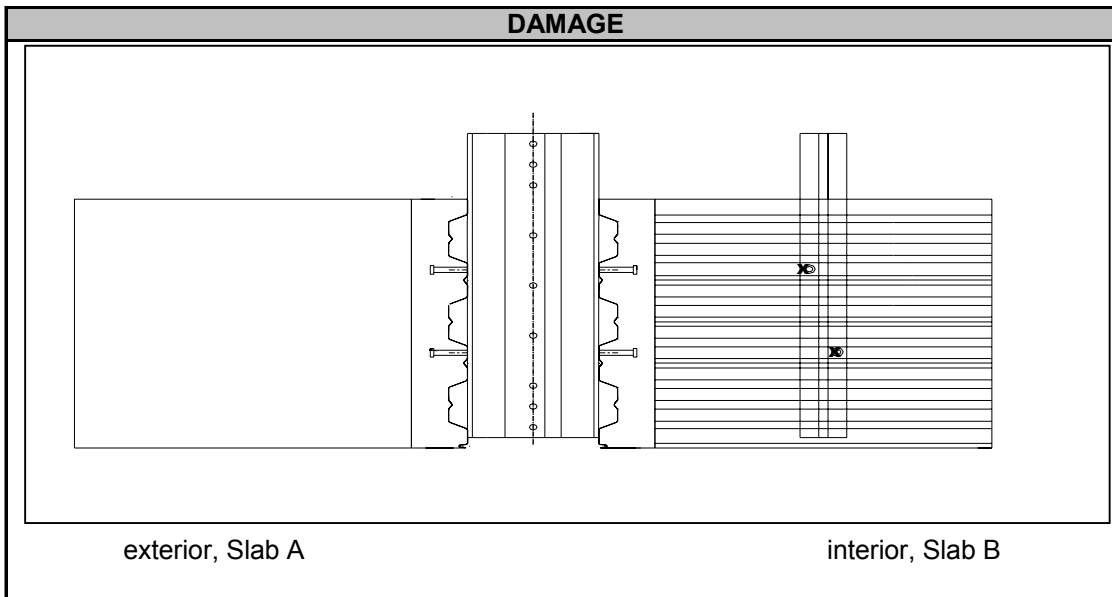

COMMENTS
Failure Mode: Screw Shear Screw Rotation $\approx 20^\circ - 30^\circ$ X = Screw sheared off

Table G-12: XOREX50-Strong Stud-2 Test Data

Shear	Normal	Slip							
Load	Load	(in)							
(kips)	(kips)	SC-1	SC-2	SC-3	SC-4	SC-5	SC-6	SC-7	SC-8
-0.04	0.00	-0.001	0.000	-0.001	-0.001	0.000	-0.001	0.000	0.000
3.22	0.77	0.000	0.001	0.001	0.000	-0.001	-0.001	0.003	0.000
10.91	1.34	0.000	0.001	0.001	0.000	0.000	0.000	0.003	0.000
14.33	1.54	0.000	0.001	0.000	0.000	0.000	-0.001	0.003	0.000
19.18	1.99	0.000	0.001	0.001	0.000	-0.001	-0.001	0.005	0.000
21.99	2.26	0.000	0.001	0.001	0.000	0.000	0.000	0.007	0.000
24.71	2.58	0.000	0.001	0.001	0.000	0.000	0.000	0.010	0.000
27.24	3.08	0.000	0.001	0.003	0.000	0.000	0.000	0.012	0.000
31.80	3.22	0.000	0.001	0.004	0.000	0.001	0.000	0.016	0.000
34.73	3.74	0.000	0.001	0.006	0.000	0.004	-0.001	0.019	0.000
38.84	4.10	0.000	0.001	0.008	0.000	0.007	-0.001	0.021	0.000
44.75	4.54	0.001	0.001	0.013	0.000	0.012	0.000	0.025	0.000
48.09	4.95	0.000	0.003	0.015	0.001	0.016	-0.001	0.026	0.000
51.67	5.68	0.003	0.005	0.019	0.007	0.021	0.000	0.031	0.000
54.68	5.60	0.006	0.007	0.022	0.007	0.026	0.000	0.034	0.000
60.14	6.13	0.016	0.013	0.032	0.013	0.040	0.000	0.042	0.000
63.44	6.65	0.026	0.019	0.042	0.020	0.051	0.000	0.046	0.000
68.20	7.24	0.055	0.039	0.069	0.039	0.080	0.001	0.060	0.000
71.17	7.67	0.079	0.056	0.092	0.057	0.104	0.011	0.069	0.008
72.56	7.99	0.1487	0.1190	0.1660	0.1190	0.1668	0.0611	0.1163	0.0572

Test XOREX50-Strong Stud-2: Load vs. Slip (A)

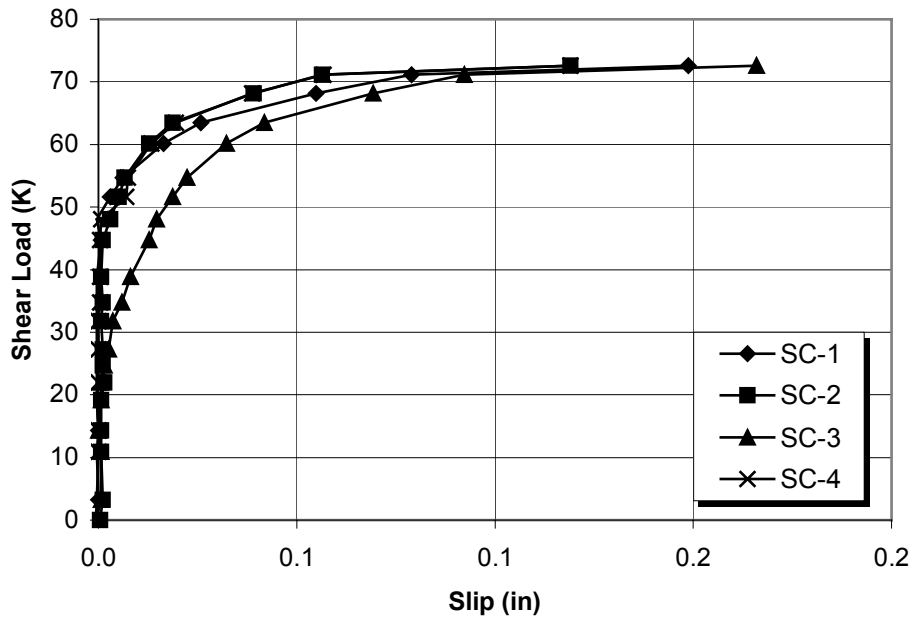

Test XOREX50-Strong Stud-2: Load vs. Slip (B)

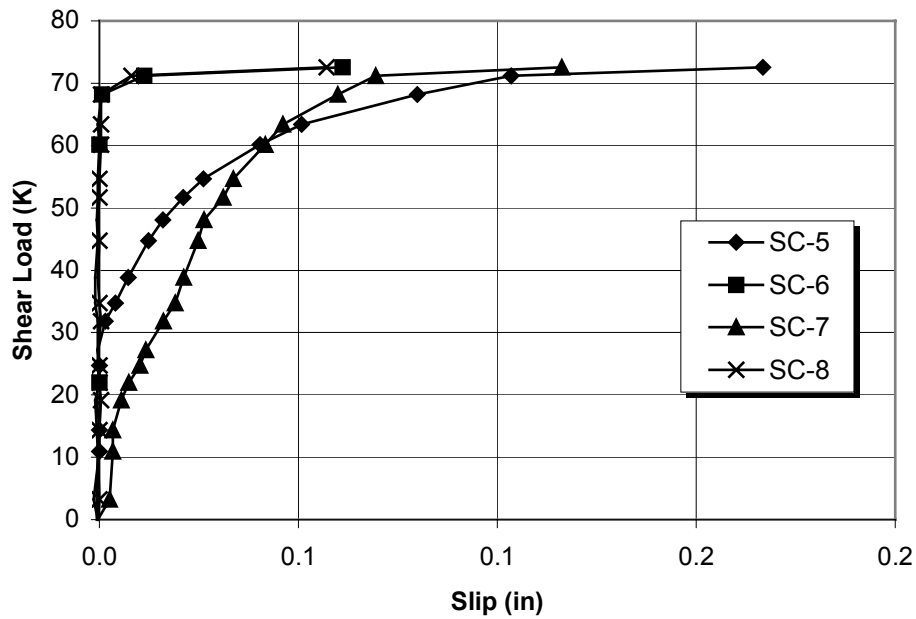

Figure G-12: XOREX50-Strong Stud-2 Applied Shear Load vs. Slip

PUSHOUT TEST SUMMARY SHEET

Test: Microfiber-MD-Screw-1

Test Date: 28-Aug-01

SPECIMEN DESCRIPTION			
Screw:	Height: <u>3.0 in.</u>	No. Per Specimen: <u>10</u>	
Deck:	Type: <u>1.5VL, 22 ga</u>	Width: <u>36 in.</u>	Length: <u>36 in.</u>
	F _y : <u>54 ksi</u>	F _u : <u>63 ksi</u>	
Base Member:	Section: <u>2L 2.00x2.00x0.187</u>		
	F _y : <u>69 ksi</u>	F _u : <u>88.5 ksi</u>	
Slab:	Thickness: <u>3.50 in.</u>	f' _c : <u>3600 psi</u>	
Rebar:	Size: <u>No. 4</u>	No. Per Specimen: <u>8</u>	
		Height Above Deck: <u>0.75 in.</u>	
Mesh:	Type: <u>1.5 lb/cyd Microfiber-MD</u>		

TEST RESULTS			
Peak Shear Load: <u>49.92 kips</u>			
Peak Shear Load Per Screw: <u>4.492 kips</u>			
Slip at Peak Shear Load:	SC1: <u>0.750 in.</u>	SC5: <u>0.761 in.</u>	
	SC2: <u>0.797 in.</u>	SC6: <u>0.709 in.</u>	
	SC3: <u>0.728 in.</u>	SC7: <u>N/A</u>	
	SC4: <u>0.788 in.</u>	SC8: <u>0.697 in.</u>	

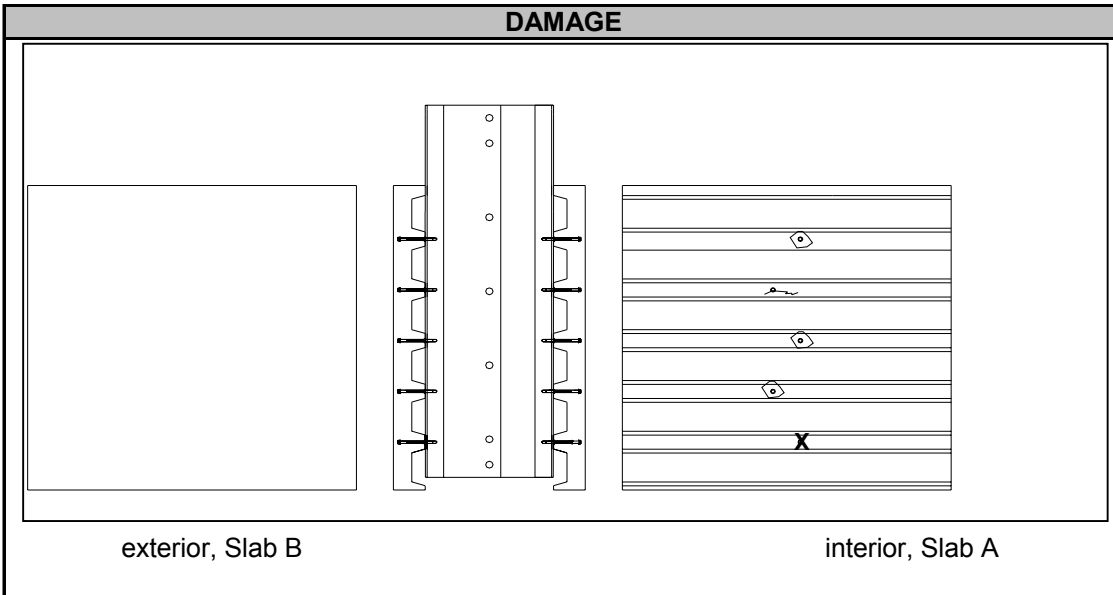

COMMENTS
Failure Mode: Screw Shear Screw Rotation $\approx 30^\circ - 40^\circ$ X = Screw sheared off

Table G-13:Microfiber-MD-Screw-1 Test Data

Shear	Normal	Slip							
Load	Load	(in)							
(kips)	(kips)	SC-1	SC-2	SC-3	SC-4	SC-5	SC-6	SC-7	SC-8
0.04	0.00	0.000	0.000	0.000	0.000	-0.001	-0.001	0.000	0.000
6.15	0.44	0.000	0.002	0.000	0.000	0.000	0.000	0.000	0.000
8.22	1.13	-0.001	0.002	0.000	-0.001	0.000	0.000	-0.001	0.000
13.93	1.40	0.000	0.004	0.001	0.000	0.001	0.000	0.000	0.000
19.26	2.02	-0.001	0.012	0.010	0.008	0.010	0.000	0.000	0.009
22.07	2.44	0.000	0.017	0.014	0.012	0.014	-0.001	0.000	0.014
23.94	2.61	0.003	0.028	0.022	0.019	0.019	0.000	-0.001	0.018
26.75	2.87	0.008	0.038	0.030	0.028	0.028	0.000	-0.001	0.029
29.48	3.41	0.017	0.050	0.044	0.040	0.040	0.000	0.000	0.043
30.50	3.43	0.031	0.064	0.058	0.055	0.055	0.004	0.000	0.059
34.49	3.88	0.175	0.212	0.204	0.203	0.185	0.135	0.043	0.204
37.99	4.45	0.244	0.290	0.270	0.283	0.252	0.210	0.084	0.286
40.47	4.90	0.289	0.341	0.308	0.333	0.304	0.259	0.107	0.339
45.93	5.22	0.434	0.499	0.427	0.491	0.462	0.410	0.199	0.499
48.49	5.48	0.494	0.563	0.480	0.557	0.521	0.470	0.254	0.564
49.92	6.05	0.750	0.797	0.728	0.788	0.761	0.709	0.441	0.697

Test Microfiber-MD Screw-1: Load vs. Slip (A)

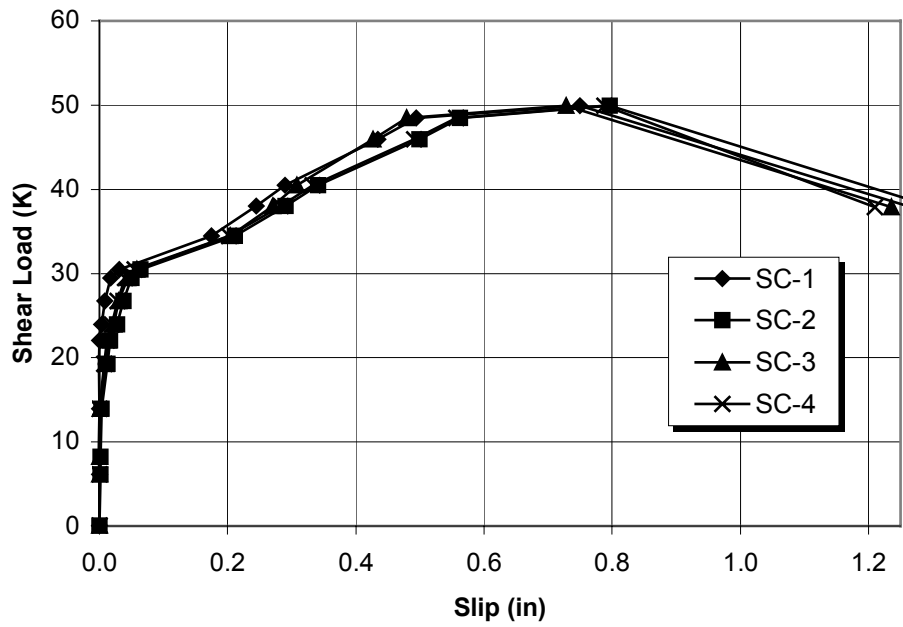

Test Microfiber-MD-Screw-1: Load vs. Slip (B)

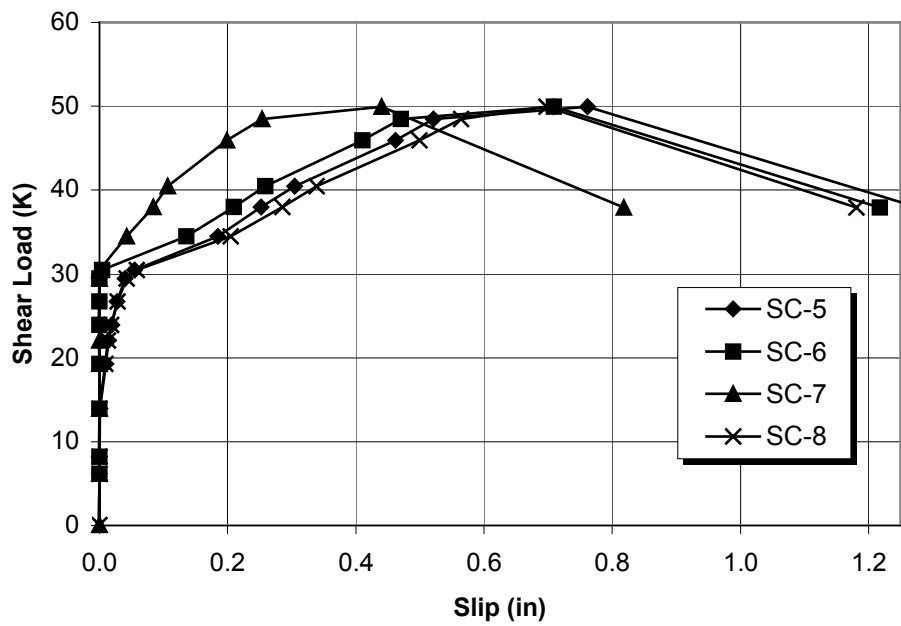

Figure G-13: Microfiber-MD Screw-1 Applied Shear Load vs. Slip

PUSHOUT TEST SUMMARY SHEET

Test: Microfiber-MD Screw-2

Test Date: 28-Aug-01

SPECIMEN DESCRIPTION			
Screw:	Height: <u>3.0 in.</u>	No. Per Specimen: <u>10</u>	
Deck:	Type: <u>1.5VL, 22 ga</u>	Width: <u>36 in.</u>	Length: <u>36 in.</u>
	F _y : <u>69 ksi</u>	F _u : <u>88.5 ksi</u>	
Base Member:	Section: <u>2L 2.00x2.00x0.187</u>		
	F _y : <u>54 ksi</u>	F _u : <u>63 ksi</u>	
Slab:	Thickness: <u>3.50 in.</u>	f' _c : <u>3600 psi</u>	
Rebar:	Size: <u>No. 4</u>	No. Per Specimen: <u>8</u>	
		Height Above Deck: <u>0.75 in.</u>	
Mesh:	Type: <u>1.5 lb/cyd Microfiber-MD</u>		

TEST RESULTS			
Peak Shear Load: <u>52.97 kips</u>			
Peak Shear Load Per Screw: <u>5.297 kips</u>			
Slip at Peak Shear Load:	SC1: <u>0.682 in.</u>	SC5: <u>0.585 in.</u>	
	SC2: <u>0.707 in.</u>	SC6: <u>0.738 in.</u>	
	SC3: <u>0.662 in.</u>	SC7: <u>0.568 in.</u>	
	SC4: <u>0.715 in.</u>	SC8: <u>0.735 in.</u>	

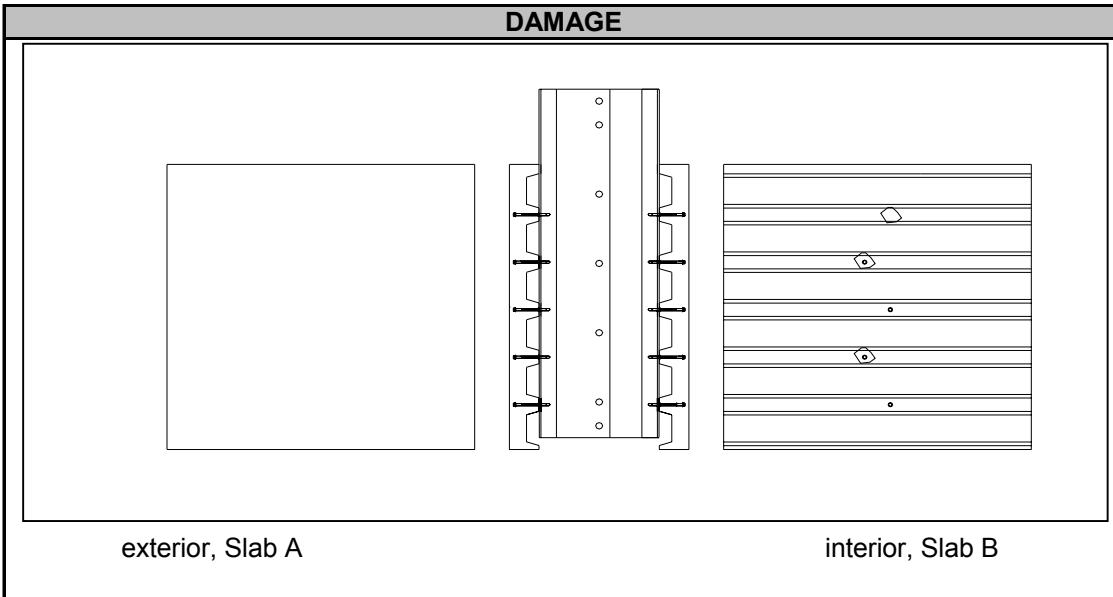

COMMENTS
Failure Mode: Screw Shear Screw Rotation ≈ 30° - 40° X = Screw sheared off

Table G-14: Microfiber-MD Screw-2 Test Data

Shear	Normal	Slip							
Load	Load	(in)							
(kips)	(kips)	SC-1	SC-2	SC-3	SC-4	SC-5	SC-6	SC-7	SC-8
-0.04	0.00	0.000	-0.001	0.000	0.000	-0.001	-0.001	-0.001	0.000
5.37	0.82	0.000	0.000	0.000	0.000	0.000	0.000	0.000	0.003
10.22	1.19	0.000	0.000	0.000	0.000	-0.001	0.000	0.000	0.004
15.19	1.51	0.000	0.000	0.000	0.004	-0.001	0.003	0.001	0.009
18.97	1.99	0.000	0.002	0.002	0.008	0.000	0.010	0.003	0.015
23.33	2.43	0.000	0.010	0.009	0.014	0.000	0.020	0.007	0.025
26.87	3.00	0.007	0.020	0.017	0.024	0.005	0.031	0.014	0.036
29.60	3.31	0.016	0.031	0.026	0.035	0.013	0.044	0.021	0.049
32.29	3.67	0.037	0.053	0.044	0.060	0.032	0.071	0.035	0.076
34.73	4.03	0.132	0.159	0.131	0.168	0.117	0.177	0.106	0.180
37.91	4.24	0.257	0.286	0.245	0.295	0.230	0.309	0.220	0.311
41.41	4.57	0.373	0.405	0.359	0.418	0.309	0.421	0.329	0.422
43.81	5.04	0.422	0.454	0.407	0.466	0.346	0.468	0.368	0.469
46.46	5.42	0.490	0.516	0.473	0.532	0.405	0.530	0.417	0.530
50.65	5.62	0.618	0.641	0.599	0.654	0.524	0.668	0.535	0.664
50.61	5.62	0.618	0.640	0.599	0.654	0.525	0.668	0.535	0.663
52.97	6.06	0.682	0.707	0.662	0.715	0.585	0.738	0.568	0.735

Test Microfiber-MD Screw-2: Load vs. Slip (A)

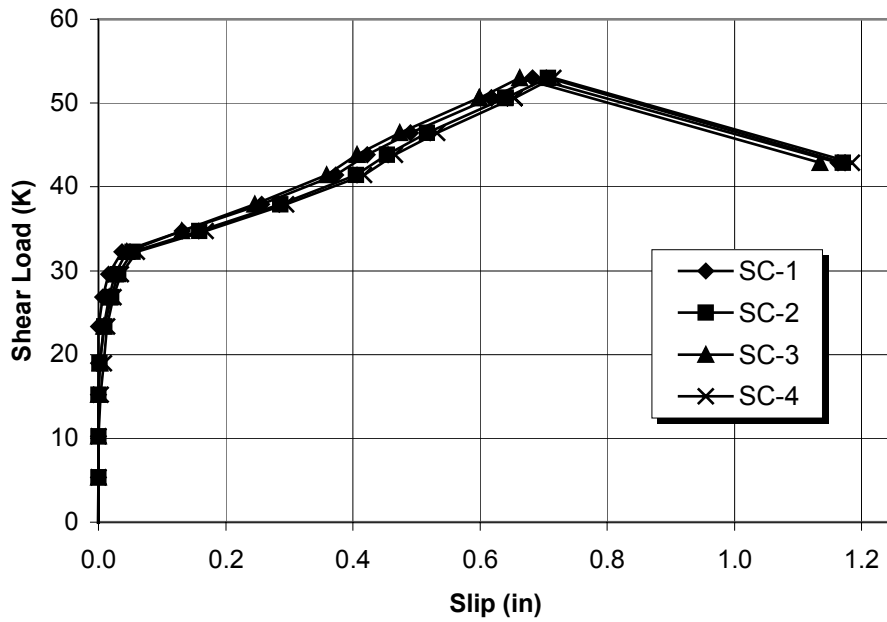

Test Microfiber-MD Screw-2: Load vs. Slip (B)

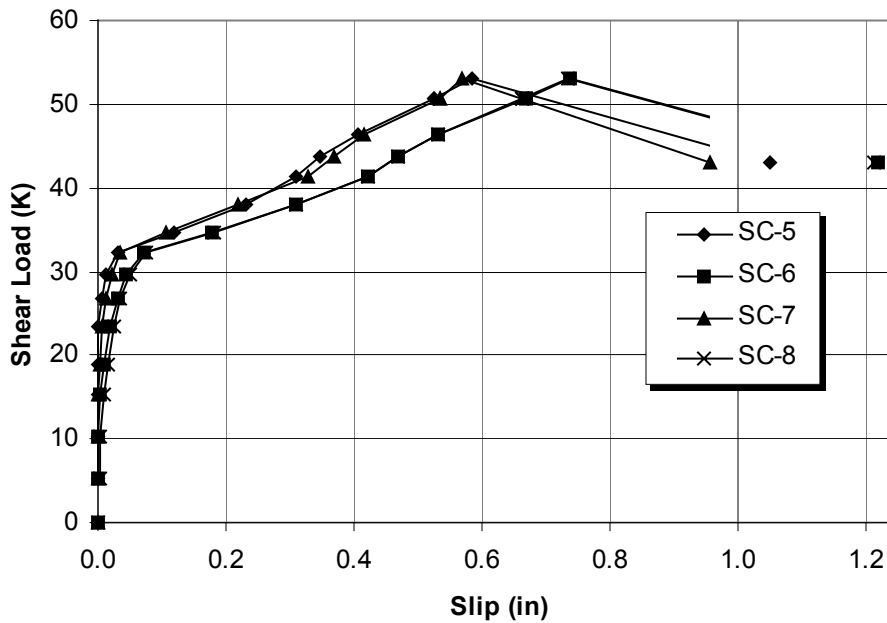

Figure G-14 Microfiber-MD Screw-2 Applied Shear Load vs. Slip

PUSHOUT TEST SUMMARY SHEET

Test: MicrofiberMD-Wstuds-1

Test Date: 29-Aug-01

SPECIMEN DESCRIPTION			
Stud:	3/4" dia x 4 3/8" Long	No. Per Specimen: <u>4</u>	
Deck:	Type: <u>2.0VL, 20 ga</u>	Width: <u>36 in.</u>	Length: <u>36 in.</u>
	F_y : <u>48 ksi</u>	F_u : <u>51 ksi</u>	
Base Member:	Section: <u>2L-4.00x0.500</u>		
	F_y : <u>54 ksi</u>	F_u : <u>79 ksi</u>	
Slab:	Thickness: <u>6.00 in.</u>	f'_c : <u>3600 psi</u>	
Rebar:	Size: <u>No. 4</u>	No. Per Specimen: <u>6</u>	
		Height Above Deck: <u>1.00 in.</u>	
Mesh:	Type: <u>1.5 lb/cyd -Microfiber-MD</u>		

TEST RESULTS			
Peak Shear Load: <u>51.79 kips</u>			
Peak Shear Load Per Stud: <u>12.95 kips</u>			
Slip at Peak Shear Load:	SC1: <u>0.1320 in.</u>	SC5: <u>0.1350 in.</u>	
	SC2: <u>0.1000 in.</u>	SC6: <u>0.0970 in.</u>	
	SC3: <u>0.1320 in.</u>	SC7: <u>0.1470 in.</u>	
	SC4: <u>0.1080 in.</u>	SC8: <u>0.0910 in.</u>	

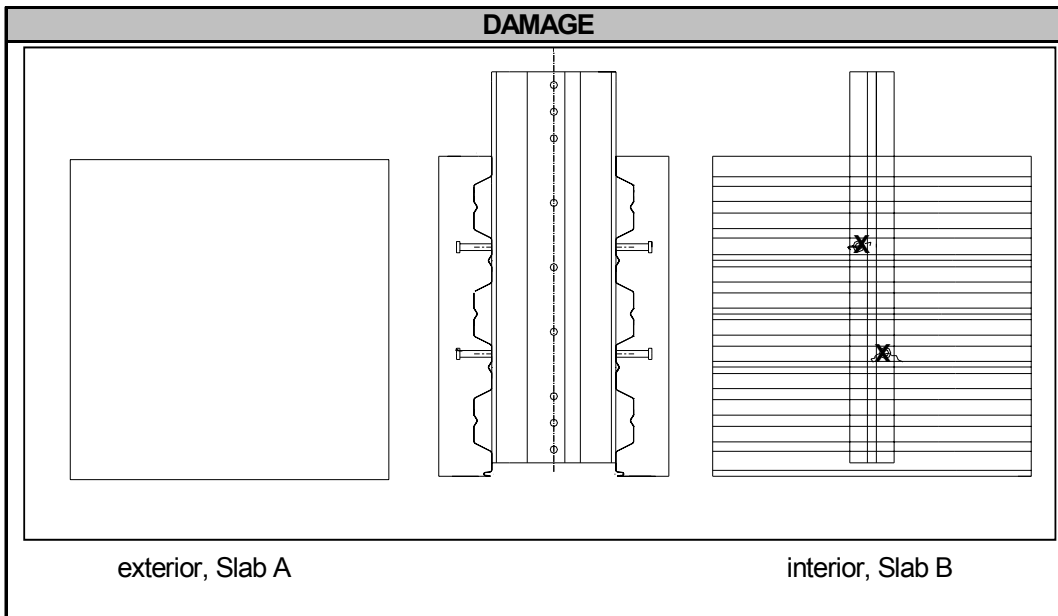

COMMENTS
Failure Mode: Stud X = Stud sheared off

Table G-15: Microfiber-MD Weak Stud-1 Test Data

Shear Load (kips)	Normal Load (kips)	Slip (in)							
		SC-1	SC-2	SC-3	SC-4	SC-5	SC-6	SC-7	SC-8
-0.04	0.00	0.000	0.000	0.000	-0.001	0.000	0.000	0.000	0.000
4.85	0.61	0.000	0.000	0.000	0.001	0.000	0.000	0.003	0.000
12.30	1.20	0.004	0.001	0.004	0.004	0.000	0.000	0.009	0.000
15.19	1.53	0.006	0.000	0.006	0.006	0.003	0.000	0.012	0.001
19.06	1.91	0.012	0.006	0.010	0.010	0.009	0.001	0.019	0.003
24.84	2.48	0.020	0.013	0.020	0.017	0.019	0.007	0.027	0.008
28.30	3.05	0.026	0.016	0.024	0.022	0.025	0.012	0.034	0.012
32.82	3.48	0.038	0.026	0.037	0.030	0.038	0.021	0.047	0.020
36.32	4.01	0.049	0.037	0.048	0.041	0.052	0.035	0.062	0.029
38.48	4.23	0.055	0.041	0.053	0.047	0.059	0.036	0.069	0.034
42.35	4.47	0.075	0.056	0.071	0.063	0.077	0.050	0.088	0.047
45.40	4.76	0.090	0.067	0.088	0.075	0.093	0.064	0.103	0.059
48.33	5.11	0.107	0.081	0.105	0.089	0.110	0.078	0.122	0.072
51.79	5.50	0.132	0.100	0.132	0.108	0.135	0.097	0.147	0.091

Test Microfiber-MD Weak Stud-1: Load vs. Slip (A)

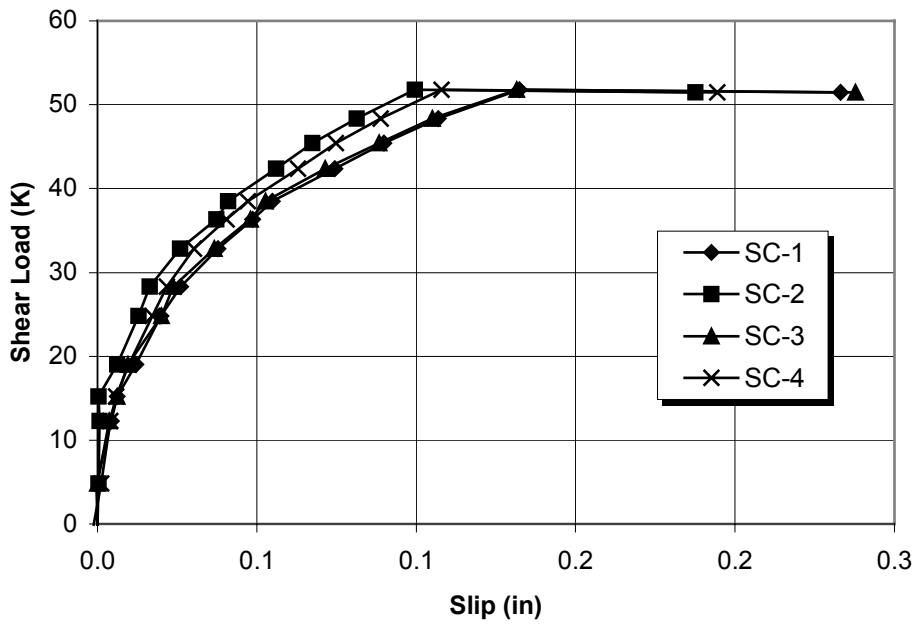

Test Microfiber-MD Weak Stud-1: Load vs. Slip (B)

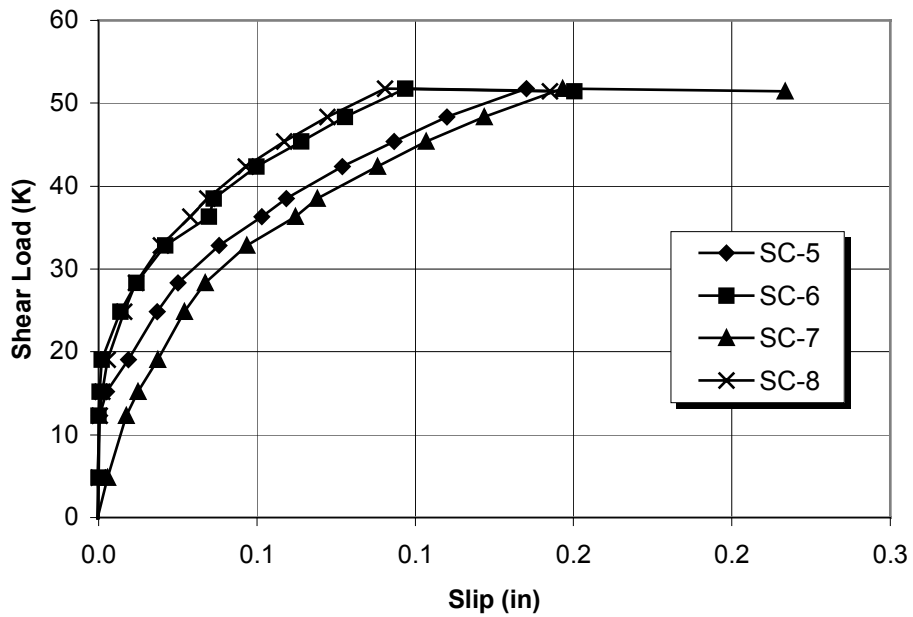

Figure G-15: Microfiber-MD Weak Stud-1 Applied Shear Load vs. Slip

PUSHOUT TEST SUMMARY SHEET

Test: MicrofiberMD-Wstuds-2

Test Date: 30-Aug-01

SPECIMEN DESCRIPTION			
Stud:	3/4" dia x 4 3/8" Long	No. Per Specimen: <u>4</u>	
Deck:	Type: <u>2.0VL, 20 ga</u>	Width: <u>36 in.</u>	Length: <u>36 in.</u>
	F_y : <u>48 ksi</u>	F_u : <u>51 ksi</u>	
Base Member:	Section: <u>2L-4.00x0.500</u>		
	F_y : <u>54 ksi</u>	F_u : <u>79 ksi</u>	
Slab:	Thickness: <u>6.00 in.</u>	f'_c : <u>3600 psi</u>	
Rebar:	Size: <u>No. 4</u>	No. Per Specimen: <u>6</u>	
		Height Above Deck: <u>1.00 in.</u>	
Mesh:	Type: <u>1.5 lb/cyd -Microfiber-MD</u>		

TEST RESULTS			
Peak Shear Load: <u>75.29 kips</u>			
Peak Shear Load Per Stud: <u>18.82 kips</u>			
Slip at Peak Shear Load:	SC1: <u>0.2705 in.</u>	SC5: <u>0.2231 in.</u>	
	SC2: <u>0.2230 in.</u>	SC6: <u>0.1314 in.</u>	
	SC3: <u>0.2528 in.</u>	SC7: <u>0.1206 in.</u>	
	SC4: <u>0.1783 in.</u>	SC8: <u>N/A</u>	

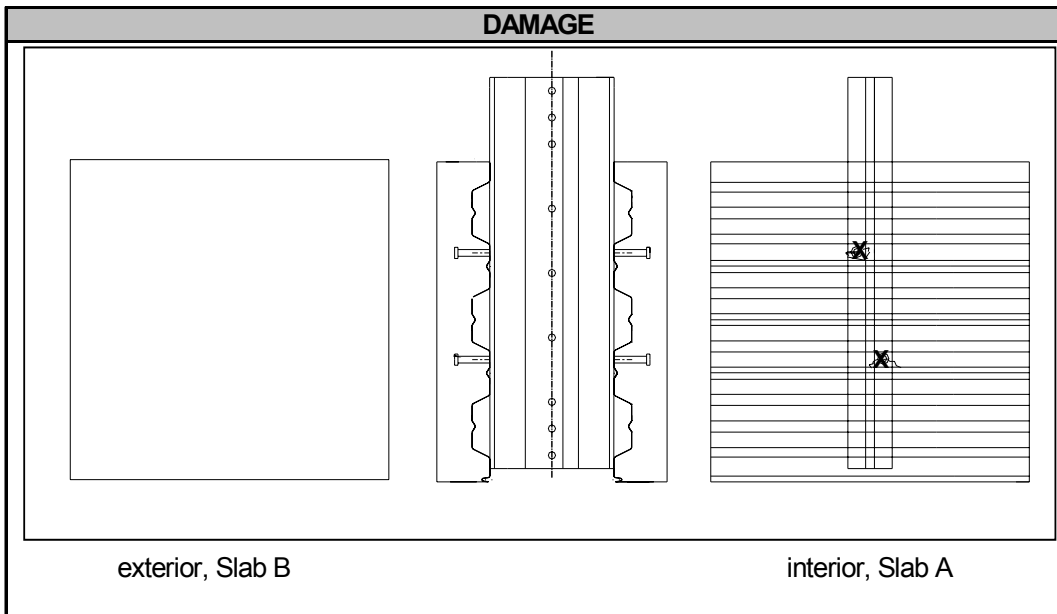

COMMENTS
Failure Mode: Stud Debonding X = Stud sheared off

Table G-16: Microfiber-MD Weak Stud-2 Test Data

Shear Load (kips)	Normal Load (kips)	Slip (in)							
		SC-1	SC-2	SC-3	SC-4	SC-5	SC-6	SC-7	SC-8
0.00	0.00	0.000	0.000	-0.001	0.000	0.000	0.000	0.000	-0.001
4.85	0.78	0.000	0.001	-0.001	0.000	0.006	0.001	-0.001	0.003
10.38	1.34	0.000	0.001	-0.001	0.000	0.009	0.003	0.000	0.006
15.47	1.45	-0.001	0.001	-0.001	0.000	0.015	0.010	0.000	0.011
19.10	2.02	0.000	0.001	0.000	0.001	0.020	0.015	0.000	0.015
22.64	2.34	0.000	0.003	0.000	0.001	0.025	0.021	0.000	0.021
25.45	2.68	0.002	0.005	0.000	0.000	0.032	0.029	0.000	0.027
28.50	3.15	0.004	0.008	0.000	0.001	0.040	0.039	0.001	0.037
33.96	3.56	0.010	0.013	0.003	0.001	0.057	0.059	0.001	0.055
37.74	3.94	0.018	0.019	0.009	0.000	0.075	0.084	0.001	0.078
44.50	4.50	0.031	0.033	0.020	0.001	0.100	0.113	0.007	0.108
47.19	4.79	0.041	0.042	0.030	0.001	0.120	0.137	0.012	0.130
45.40	5.10	0.057	0.056	0.045	0.001	0.186	0.218	0.031	0.208
48.66	5.04	0.162	0.164	0.141	0.001		0.660	0.157	0.644
50.86	5.50	0.484	0.511	0.455	0.255		0.964	0.215	0.953

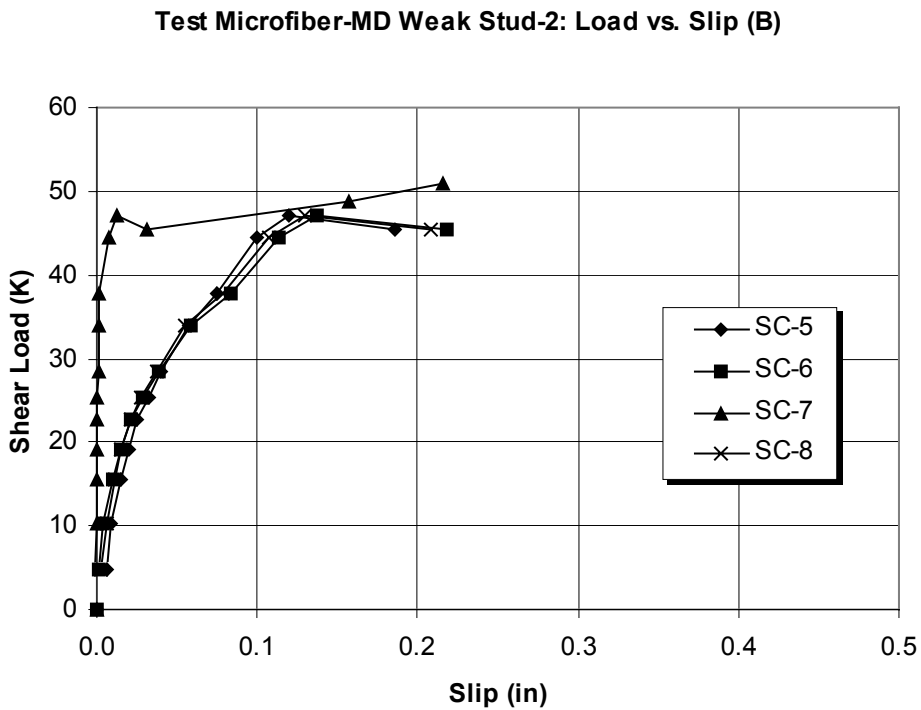
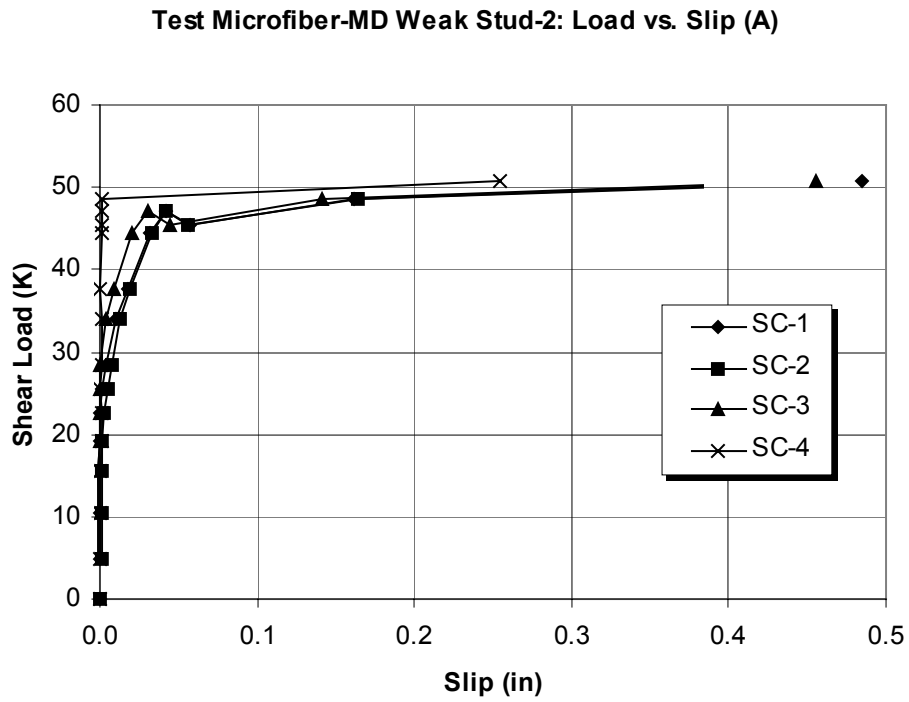

Figure G-16: Microfiber-MD Weak Stud-2 Applied Shear Load vs. Slip

APPENDIX H

FIBER PROPERTIES

Two types of fibers were used in this study: a ribbed steel fiber known as XOREX- steel fiber, and a synthetic fiber known as Fibermesh or Microfiber-MD. Properties, advantages and uses of these fibers are presented in this Appendix. NOVOCON STEEL FIBRE, a division of Synthetic Industries, Inc, manufacturer of these products and sponsor of this project, provided the information in this appendix.

FIBER PROPERTIES

XOREX™-STEEL FIBER

XOREX™-STEEL FIBER is a low carbon, cold drawn steel fiber used for concrete reinforcement. These fibers improve mechanical bonding capacity exceeding most performance specifications for enhancing concrete's flexural and shear strength, fatigue endurance, impact resistance and ductility. Some of its properties are:

Fiber Length:	1.5 in. (38 mm) also available in 1.0, 2.0, and 2.5 in.
Average Equivalent Diameter:	0.040 in. (1 mm)
Minimum Tensile Strength:	120,000 psi (828 Mpa)
Deformation:	Continuously Deformed Circular Segment
Appearance:	Bright and Clean Wire

The primary applications of XOREX steel fibers include commercial and industrial slabs on grade, shotcrete, composite metal decks, overlays, equipment foundations and highway pavements. Some of its benefits include the following:

- Complies with ASTM A820, Type I, cold drawn high tensile deformed steel wire
- Meets toughness performance Level III
- Variable equivalent diameter and a continuous deformed shape provide superior reinforcement resulting in tighter cracks and joints.
- High tensile strength fiber bridging joints or cracks to provide superior aggregate interlock and increased load carrying capacity.
- Provides uniform, multi-directional concrete reinforcement
- Requires less labor to incorporate into concrete applications than rebar and wire mesh.
- No special equipment is needed to mix, place or finish.
- Provides superior contraction joint stability and crack width control

* This information was provided by NOVOCON STEEL FIBRE, a division of Synthetic Industries, Inc.

FIBERMESH®

Fibermesh® is a micro-reinforcement of 100 percent virgin homopolymer polypropylene fibrillated fibers. These fibers are used to control cracking due to drying shrinkage and thermal expansion/contraction, lowered water migration, increased impact capacity, shatter resistance, abrasion resistance and residual strength. Some of its chemical and physical properties are:

Absorption:	Nil
Specific Gravity:	0.91
Fiber Length:	1/8 – 2 ¼ in.
Electrical Conductivity:	Low
Acid and Salt Resistance:	High
Young's Modulus:	0.5 (3.5 kN/mm ²)
Melt Point:	324° F
Ignition Point:	1,100° F
Thermal Conductivity:	Low
Alkali Resistance:	Alkali Proof

This product is applicable to all types of concrete, which demonstrate a need for toughness, resistance to intrinsic cracking and improved water tightness. Some of its applications include slabs on grade, composite decks, shotcrete, walls, sidewalks, driveways, slope paving, and maintenance jobs. Some of its advantages are:

- Acceptance by National Codes as an alternate method of secondary reinforcing to traditional systems
- Non-magnetic, rustproof and alkali proof material.
- Requires no minimum amount of concrete cover and is always positioned in compliance with codes.
- Safe and easy to use: reduces construction time and hassle on the jobsite.

* This information was provided by NOVOCON STEEL FIBRE, a division of Synthetic Industries, Inc.

APPENDIX I

SAMPLE CALCULATIONS

This appendix includes an example for calculations of the following:

- Composite Slab Strength Capacity using First Yield Method and ASCE Appendix D (Chapter 3)
- Effective width for concentrated loads using ASCE method
- Luttrell's (1995) Method for Strength Capacity of Composite Slabs with Concentrated Load (Chapter 5)

Example I-1: First Yield Method for Composite Slabs (Example for WWF Slab, $f'_c = 4100$ psi)

$A_s =$ cross-sectional area of steel deck = $0.519 \text{ in}^2/\text{ft}$
 $b =$ unit width of slab = 12 in
 $b_d =$ width of composite test slab = 6 ft.
 $B_b =$ width of the bottom flange of the steel deck = 5 in.
 $B_t =$ width of the top flange of the steel deck = 5 in.
 $C_s =$ cell spacing = 12 in.
 $d =$ distance from the top of the slab to the centroidal axis of the steel deck = 3.5 in.
 $d_d =$ overall depth of steel deck profile = 2 in.
 $D_w =$ width of the web of the steel deck = 2.24 in.
 $t =$ uncoated thickness of the steel deck = 0.0358 in.
 $h =$ nominal out-to-out depth of composite slab = 4.5 in.
 $F_y =$ yield strength of steel = 50 ksi (measured value)
 $f_{yc} =$ corrected steel yield stress = 49.98 ksi
 $f'_c =$ compressive strength of concrete = 4100 psi
 $E_c =$ modulus of elasticity of the concrete = $57000(f'_c)^{0.5} = 57000(4100)^{0.5} = 3650$ ksi
 $E_s =$ modulus of elasticity of the steel = 29,500,000 psi
 $n =$ modular ratio = $E_s/E_c = 29,500/3650 = 8.1$
 $\rho = A_s/bd = (0.519 \text{ in}^2/\text{ft})/(12 \text{ in.} * 3.5 \text{ in.}) = 0.0124/\text{ft.}$
 $\rho n = (0.0124/\text{ft}) * 8.1 = 0.100$
 $y_{cc} = d \{ [2\rho n + (\rho n)^2]^{0.5} - \rho n \} = 3.5 \{ [2 * 0.100 + (0.100)^2]^{0.5} - 0.100 \} = 1.254 \text{ in.}$
 $e^x =$ exponential function $w/x = 25(p_h)$
 $e_3 = h - (y_{cc}/3) = 4.5 - (1.254/3) = 4.08 \text{ in.}$
 $e_1 = e_3 - d_d = 4.08 - 2 = 2.08 \text{ in.}$
 $e_2 = e_3 - (d_d/2) = 4.08 - (2/2) = 3.08 \text{ in.}$
 $T_1 = f_{yc} B_t t [(h - y_{cc} - d_d)/(h - y_{cc})] = (49.98)(5)(0.0358) [(4.5 - 1.254 - 2)/(4.5 - 1.254)] = 3.43 \text{ kips}$
 $T_2 = f_{yc} 2D_w t [(h - y_{cc} - d_d/2)/(h - y_{cc})] = (49.98)(2)(2.24)(0.0358) [(4.5 - 1.254 - 2/2)/(4.5 - 1.254)] = 5.54 \text{ kips}$
 $T_3 = f_{yc} B_b t = (49.98)(5)(0.0358) = 8.95 \text{ kips}$
 $M_{et} = (T_1 e_1 + T_2 e_2 + T_3 e_3) = (3.43 * 2.08 + 5.54 * 3.08 + 8.95 * 4.08) = 60.73 \text{ kip-in./ft}$
 $= 30.36 \text{ k-ft (for entire width)}$

Example I-2: ASCE Appendix D Alternate Method

$M_{et} = 60.73 \text{ in.-kip/ft} = 5,061 \text{ ft-lbs/ft}$
 $M_t = K M_{et} 12/C_s$
 $K = K_3/(K_1 + K_2) \leq 1.0$ (For the dimensions of this slab, $K_3/(K_1 + K_2) > 1.0 \therefore K = 1.0$)
 $M_t = 1.0(5061)(12/12) = 5,061 \text{ ft-lbs/ft}$

Example I-3: ASCE Method with Concentrated Load (Example for WWF Slab)

$$d = 5.5 \text{ in.}$$

$$f'_c = 3.34 \text{ ksi}$$

$$E_c = 3300 \text{ ksi}$$

$$B_e = b_2 + t_c$$

Where,

$$b_2 = \text{width of the load area in the transverse direction} = 12 \text{ in.}$$

$$t_c = \text{cover depth of concrete} = 3.5 \text{ in.}$$

$$B_e = 12 + 3.5 = 15.5 \text{ in.}$$

$$M_t = 6,557 \text{ ft-lbs/ft (using same procedure as example I-2)}$$

$$M_{th} = B_e M_t = 6,557(15.5/12) = 8,470 \text{ ft-lbs.}$$

Example I-4: Luttrell's Method (1995)

$$B_{th} = 22ft(h_c/h) = 22(3.5/5.5) = 14.0 \text{ ft. Use next lowest odd integer, } B_{th} = 13.0 \text{ ft.}$$

$$a_i = a_0 \{ \cos[\{ \pi x \} / B_{th}] \} \{ 1 - [(2x) / B_{th}] \}$$

$$a_0 = 1.0$$

$$a_1 = 0.8216$$

$$a_2 = 0.6130$$

$$a_3 = 0.4030$$

$$a_4 = 0.2186$$

$$a_5 = 0.0818$$

$$a_6 = 0.0093$$

$$B_e = \sum a_i = [1 + 2(0.8216 + 0.6130 + 0.4030 + 0.2186 + 0.0818 + 0.0093)] = 5.2944 \text{ ft.}$$

$$M_{th} = B_e M_t = 5.2944 * 6557 = 37,716 \text{ ft/lbs.}$$

VITA

Marcela was born in San Salvador, El Salvador on November 30, 1976 from Salvadorian father: Mauricio Guirola, and Nicaraguan mother: Elizabeth Vivas. She has one brother, Mauricio; and two sisters, Fermina and Ximena.

In 1980 the family moved to Nicaragua as a result of the civil war in El Salvador. They lived in Nicaragua during the Sandinistas time and decided to move back to El Salvador in 1985.

Marcela attended the British Academy in San Salvador and graduated in 1994. On this same year, she went to Virginia Tech in Blacksburg, Virginia to study Engineering. Her family moved back to Nicaragua in 1997. In 1999 she obtained her bachelors degree in Civil and Environmental Engineering from the same school. She continued with her graduate studies at the same university and obtained her masters degree in Civil Engineering with a concentration in structures in 2001.

Marcela wishes to return to Nicaragua and hopefully some day work independently.