

SCAG[®]

POWER EQUIPMENT

OPERATOR'S MANUAL



Turf Tiger Diesel Powered

Model: STT61V-25KBD
STT72V-25KBD
STT-25KBD

Congratulations on owning a Scag mower! This manual contains the operating instructions and safety information for your Scag mower. Reading this manual can provide you with assistance in maintenance and adjustment procedures to keep your mower performing to maximum efficiency. The specific models that this book covers are listed on the inside cover. Before operating your machine, please read all the information enclosed.



WARNING

FAILURE TO FOLLOW SAFE OPERATING PRACTICES MAY RESULT IN SERIOUS INJURY OR DEATH.

- Read this manual completely as well as other manuals that came with your mower.
- DO NOT operate on steep slopes. To check a slope, attempt to back up it (with the cutter deck down). If the machine can back up the slope without the wheels slipping, reduce speed and use extreme caution.
- Under no circumstances should the machine be operated on slopes greater than 15 degrees. ALWAYS FOLLOW OSHA APPROVED OPERATION.
- DO NOT mow on wet grass. Wet grass reduces traction and steering control.
- Keep all shields in place, especially the grass discharge chute.
- Before performing any maintenance or service, stop the machine and remove the spark plug wire and ignition key.
- If a mechanism becomes clogged, stop the engine before cleaning.
- Keep hands, feet and clothing away from power-driven parts.
- Keep others off the mower (only one person at a time)

REMEMBER - YOUR MOWER IS ONLY AS SAFE AS THE OPERATOR!

HAZARD CONTROL AND ACCIDENT PREVENTION ARE DEPENDENT UPON THE AWARENESS, CONCERN, PRUDENCE, AND PROPER TRAINING OF THE PERSONNEL INVOLVED IN THE OPERATION, TRANSPORT, MAINTENANCE, AND STORAGE OF THE EQUIPMENT.

This manual covers the operating instructions and illustrated parts list for:

STT61V-25KBD	with a serial number of	K1600001 to K1699999
STT72V-25KBD	with a serial number of	K2300001 to K2399999
STT-25KBD	with a serial number of	K2800001 to K2899999

Always use the entire serial number listed on the serial number tag when referring to this product.

Table of Contents

SECTION 1 - GENERAL INFORMATION	1
1.1 INTRODUCTION.....	1
1.2 DIRECTION REFERENCE	1
1.3 SERVICING THE ENGINE AND DRIVE TRAIN COMPONENTS.....	1
1.4 SYMBOLS	2
SECTION 2 - SAFETY INFORMATION	3
2.1 INTRODUCTION.....	3
2.2 SIGNAL WORDS	3
2.3 BEFORE OPERATION CONSIDERATIONS.....	3
2.4 OPERATION CONSIDERATIONS.....	4
2.5 ROLL-OVER PROTECTION SYSTEM	6
2.6 MAINTENANCE CONSIDERATIONS & STORAGE	8
2.7 USING A SPARK ARRESTOR.....	9
2.8 SAFETY AND INSTRUCTIONAL DECALS	10
SECTION 3 - SPECIFICATIONS	11
3.1 ENGINE	11
3.2 ELECTRICAL	11
3.3 POWER HEAD	11
3.4 CUTTER DECK	12
3.5 HYDRAULIC SYSTEM	12
3.6 WEIGHTS AND DIMENSIONS	12
3.7 PRODUCTIVITY	12
SECTION 4 - OPERATING INSTRUCTIONS	13
4.1 CONTROLS AND INSTRUMENT IDENTIFICATION	13
4.2 SAFETY INTERLOCK SYSTEM	14
4.3 INITIAL RUN-IN PROCEDURES (FIRST DAY OF USE OR APPROXIMATELY 10 HOURS).....	15
4.4 STARTING THE ENGINE	15
4.5 GROUND TRAVEL AND STEERING	15
4.6 ENGAGING THE DECK DRIVE (CUTTER BLADES).....	16
4.7 HILLSIDE OPERATION.....	17
4.8 PARKING THE MOWER	17
4.9 AFTER OPERATION	17
4.10 REMOVING CLOGGED MATERIAL	17
4.11 MOVING MOWER WITH ENGINE STOPPED	18
4.12 RECOMMENDATIONS FOR MOWING	18
4.13 ADJUSTING CUTTING HEIGHT.....	19
4.14 ADJUSTING THE HEIGHT ADJUST PEDAL	19
4.15 ADJUSTING THE STEERING LEVERS.....	20
4.16 TOWING (OPTIONAL HITCH ACCESSORY).....	20
SECTION 5 - TROUBLESHOOTING CUTTING CONDITIONS	21

SECTION 6 - ADJUSTMENTS	24
6.1 PARKING BRAKE ADJUSTMENT	24
6.2 TRAVEL ADJUSTMENTS	25
6.3 THROTTLE CONTROL ADJUSTMENTS.....	26
6.4 BELT ADJUSTMENT	26
6.5 BELT ALIGNMENT.....	27
6.6 CUTTER DECK ADJUSTMENTS	27
6.7 ELECTRIC CLUTCH ADJUSTMENT	30
SECTION 7 - MAINTENANCE.....	31
7.1 MAINTENANCE CHART - RECOMMENDED SERVICE INTERVALS	31
7.2 LUBRICATION.....	32
7.3 HYDRAULIC SYSTEM	34
7.4 ENGINE OIL	35
7.5 ENGINE FUEL SYSTEM	35
7.6 ENGINE AIR CLEANER.....	36
7.7 BATTERY	36
7.8 DRIVE BELTS.....	37
7.9 CUTTER BLADES.....	37
7.10 TIRES.....	38
7.11 CUTTER DECK GEARBOX	39
7.12 COOLING SYSTEM	39
7.13 BODY, DECK, AND UPHOLSTERY	40

GENERAL INFORMATION

1.1 INTRODUCTION

Your mower was built to the highest standards in the industry. However, the prolonged life and maximum efficiency of your mower depends on you following the operating, maintenance and adjustment instructions in this manual.

If additional information or service is needed, contact your Scag Power Equipment Dealer.

We encourage you to contact your dealer for repairs. All Scag dealers are informed of the latest methods to service this equipment and provide prompt and efficient service in the field or at their service shop. They carry a full line of Scag service parts.

THE REPLACEMENT OF ANY PART ON THIS PRODUCT BY OTHER THAN THE MANUFACTURER'S AUTHORIZED REPLACEMENT PART MAY ADVERSELY AFFECT THE PERFORMANCE, DURABILITY OR SAFETY OF THIS PRODUCT.

USE OF OTHER THAN ORIGINAL SCAG REPLACEMENT PARTS WILL VOID THE WARRANTY.

When ordering parts, always give the model and serial number of your mower. The serial number plate is located where shown in Figure 1-1.

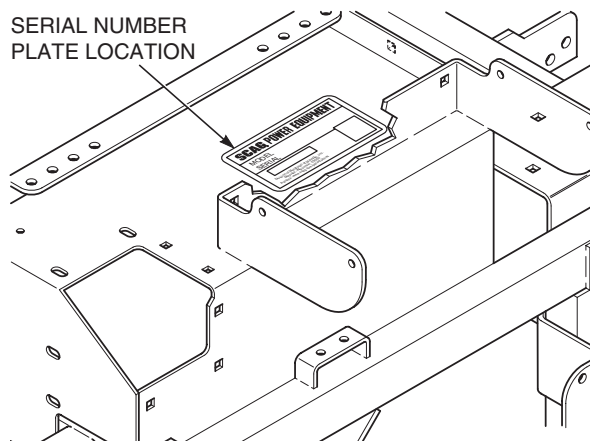

Figure 1-1. Mower Serial Number Plate Location

USE ONLY SCAG APPROVED ATTACHMENTS AND ACCESSORIES.

Attachments and accessories manufactured by companies other than Scag Power Equipment are not approved for use on this machine. See Section 8-1.



WARNING

For pictorial clarity, some illustrations and figures in this manual may show shields, guards or plates open or removed. Under no circumstances should your mower be operated without these devices in place.

All information is based upon product information available at the time of approval for printing. Scag Power Equipment reserves the right to make changes at any time without notice and without incurring any obligation.

















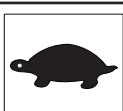

1.2 DIRECTION REFERENCE

The “Right” and “Left”, “Front” and “Rear” of the machine are referenced from the operator’s right and left when seated in the normal operating position and facing the forward travel direction.

1.3 SERVICING THE ENGINE AND DRIVE TRAIN COMPONENTS

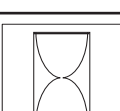
The detail servicing and repair of the engine, hydraulic pumps and gearboxes are not covered in this manual; only routine maintenance and general service instructions are provided. For service of these components during the limited warranty period, it is important to contact your Scag dealer or find a local authorized servicing agent of the component manufacturer. Any unauthorized work done on these components during the warranty period may void your warranty.

1.4 SYMBOLS

SYMBOL	DESCRIPTION	SYMBOL	DESCRIPTION
	Choke		Transmission
	Parking Brake	 48071B	Spinning Blade
	On/Start		Spring Tension on Idler
	Off/Stop		Oil
	Falling Hazard		Thrown Object Hazard
	Fast		Slow
	Continuously Variable - Linear		Cutting Element - Basic Symbol
 481039S	Pinch Point		Cutting Element - Engage
	Hour meter/Elapsed Operating Hours		Cutting Element - Disengage
	Thrown Object Hazard Keep Bystanders Away		Read Operator's Manual

SAFETY INFORMATION

2.1 INTRODUCTION

Your mower is only as safe as the operator. Carelessness or operator error may result in serious bodily injury or death. Hazard control and accident prevention are dependent upon the awareness, concern, prudence, and proper training of the personnel involved in the operation, transport, maintenance and storage of the equipment. Make sure every operator is properly trained and thoroughly familiar with all of the controls before operating the mower. The owner/user can prevent and is responsible for accidents or injuries occurring to themselves, other people or property.

READ THIS OPERATOR'S MANUAL BEFORE ATTEMPTING TO START YOUR MOWER.

A replacement manual is available from your authorized Scag Service Dealer or by contacting Scag Power Equipment, Service Department at P.O. Box 152, Mayville, WI 53050 or contact us via the Internet at www.scag.com. The manual for this machine can be downloaded by using the model and serial number or use the contact form to make your request. Please indicate the complete model and serial number of your Scag product when requesting replacement manuals.

2.2 SIGNAL WORDS



This symbol means **“Attention! Become Alert! Your Safety is Involved!”** The symbol is used with the following signal words to attract your attention to safety messages found on the decals on the machine and throughout this manual. The message that follows the symbol contains important information about safety. To avoid injury and possible death, carefully read the message! Be sure to fully understand the causes of possible injury or death.

SIGNAL WORD:

It is a distinctive word found on the safety decals on the machine and throughout this manual that alerts the viewer to the existence and relative degree of the hazard.



The signal word “DANGER” denotes that an extremely hazardous situation exists on or near the machine that could result in high probability of death or irreparable injury if proper precautions are not taken.



The signal word “WARNING” denotes that a hazard exists on or near the machine that can result in injury or death if proper precautions are not taken.



The signal word “CAUTION” is a reminder of safety practices on or near the machine that could result in personal injury if proper precautions are not taken.

Your safety and the safety of others depends significantly upon your knowledge and understanding of all correct operating practices and procedures of this machine.

2.3 BEFORE OPERATION CONSIDERATIONS



Check all hydraulic connections for tightness. Inspect all hydraulic hoses and / or lines to insure they are in good condition before operating.

1. NEVER allow children to operate this riding mower. Do not allow adults to operate this machine without proper instructions.
2. Do not mow when children and/or others are present. Keep children out of the mowing area and in the watchful care of a responsible adult other than the operator. Be alert and turn machine off if a child enters the area.

- DO NOT allow children to ride or play on the machine, it is not a toy.
- Clear the area to be mowed of objects that could be picked up and thrown by the cutter blades.
- DO NOT carry passengers.
- DO NOT operate the machine under the influence of alcohol or drugs.
- If the operator(s) or mechanic(s) cannot read English or Spanish, it is the owner's responsibility to explain this material to them.
- DO NOT wear loose fitting clothing. Loose clothing, jewelry or long hair could get tangled in moving parts. Do not operate the machine wearing shorts; always wear adequate protective clothing including long pants. Wearing safety glasses, safety shoes and a helmet is advisable and is required by some local ordinances and insurance regulations.
- Be sure the interlock switches are functioning correctly.
- Fuel is flammable; handle it with care. Fill the fuel tank outdoors. Never fill it indoors. Use a funnel or spout to prevent spillage. Clean up any spillage before starting the engine.
- DO NOT add fuel to a running or hot engine. Allow the engine to cool for several minutes before adding fuel. Never fuel indoors or inside enclosed trailers.
- Keep flammable objects (cigarettes, matches, etc.), open flames and sparks away from the fuel tank and fuel container. Use only approved containers.
- See Section 7.5 ENGINE FUEL SYSTEM for fueling procedure.
- Equipment must comply with the latest requirements per SAE J137 and/or ANSI/ASAE S279 when driven on public roads.



WARNING

Always wear hearing protection. Operating this machine over prolonged periods of time can cause loss of hearing.

- Keep the machine and attachments in good operating condition. Keep all shields and safety devices in place. If a shield, safety device or decal is defective or damaged, repair or replace it before operating the machine.



WARNING

This machine is equipped with an interlock system intended to protect the operator and others from injury. This is accomplished by preventing the engine from starting unless the deck drive is disengaged, the parking brake is on, the steering control levers are in the neutral position and the operator is in the seat. The system shuts off the engine if the operator leaves the seat with the deck drive engaged and/or the steering control levers are not in the neutral position and the parking brake is not engaged. Never operate equipment with the interlock system disconnected or malfunctioning.

- NOTE -

If the mower is driven on public roads, it must comply with state and local ordinances as well as SAE J137 and/or ANSI / ASAE S279 requirements. Contact your local authorities for regulations and equipment requirements.

- Do not operate without the side discharge chute installed and in the down position or with an optional grass catcher or mulch plate completely installed.
- Check the blade mounting bolts at frequent intervals for proper tightness.
- Make sure all hydraulic fluid connections are tight and all hydraulic hoses and lines are in good condition before starting the machine.

2.4 OPERATION CONSIDERATIONS

- Know the function of all controls and how to stop quickly.



WARNING

DO NOT operate on steep slopes. To check a slope, attempt to back up it (with the cutter deck down). If the machine can back up the slope without the wheels slipping, reduce speed and use extreme caution. Under no circumstances should the machine be operated on slopes greater than 15 degrees. See Figure 2-4, Page 8 to determine approximate slope of area to be mowed. ALWAYS FOLLOW OSHA APPROVED OPERATION.

Section 2

2. Reduce speed and exercise extreme caution on slopes and in sharp turns to prevent tipping or loss of control. Be especially cautious when changing directions on slopes.
3. Stay two cut widths away from slopes, drop offs, ditches and retaining walls.
4. To prevent tipping or loss of control, start and stop smoothly, avoid unnecessary turns and travel at reduced speed.
5. Immediately apply the parking brake if you lose steering control while operating. Inspect the machine and correct the problem before continuing to operate.
6. When using any attachment, never direct the discharge of material toward bystanders or allow anyone near the machine while in operation.
7. Before attempting to start the engine, with the operator in the seat, disengage power to the cutter deck, place the steering control levers in the neutral position and engage the parking brake.
8. If the mower discharge ever plugs, shut off the engine, remove the ignition key, and wait for all movement to stop before removing the obstruction.
13. Mow only in daylight or good artificial light.
14. NEVER raise the deck with the blades engaged.
15. Take all possible precautions when leaving the machine unattended, such as disengaging the mower, lowering the attachments, setting the parking brake, stopping the engine, and removing the key.
16. Disengage power to the attachments when transporting or when not in use.
17. The machine and attachments should be stopped and inspected for damage after striking a foreign object, and damage should be repaired before restarting and operating the machine.

CAUTION

Do not touch the engine or the muffler while the engine is running or immediately after stopping. These areas may be hot enough to cause a burn.

WARNING

DO NOT use your hand to dislodge the clogged discharge chute. Use a stick or other device to remove clogged material after the engine has stopped running and the blades have stopped turning.

DANGER

DO NOT run the engine inside a building or a confined area without proper ventilation. Exhaust fumes are hazardous and contain carbon monoxide which can cause brain injury and death.

9. Be alert for holes, rocks, roots and other hidden hazards in the terrain. Keep away from any drop-offs. Beware of overhead obstructions (low limbs, etc.), underground obstacles (sprinklers, pipes, tree roots, etc.). Cautiously enter a new area. Be alert for hidden hazards.
10. Disengage power to cutter deck before backing up. Do not mow in reverse unless absolutely necessary and then only after observation of the entire area behind the mower. If you must mow in reverse, maintain a constant lookout to the rear of the machine and mow slowly.
11. DO NOT turn sharply. Use care when backing up.
12. Disengage power to cutter deck before crossing roads, walks or gravel drives.
18. Keep hands and feet away from cutter blades and moving parts. Contact can injure.
19. Transport the mower using a heavy duty trailer or truck. Insure the trailer or truck has all of the necessary lighting and markings as required by laws, codes, and ordinances. Secure a trailer with a safety chain.
20. Be cautious when loading and unloading onto trailers or trucks. Use only a full width ramp. Ramp angle should be no more than 15 degrees. See Figure 2-4, Page 8 to determine approximate slope of the ramp. Back up the ramp and drive down forward.
21. When transporting the mower, make sure the park brake is engaged, the steering control levers are in the neutral position, the engine is off with the key removed, and the wheels have been blocked.

- 22. Tie the mower down securely using straps, chains, cable, or ropes. Both front and rear straps must be directed down and outward from machine.
- 23. Use care when approaching blind corners, shrubs, trees, or other objects that may obscure vision.
- 24. NEVER leave the machine running unattended.

2.5 ROLL-OVER PROTECTION SYSTEM

WARNING

Keep the roll bar in the raised and locked position and the seat belt securely fastened during operation. Failure to do so could cause serious injury or loss of life.

This mower has been designed for good traction and stability under normal mowing conditions. However, caution must be used when traveling on slopes, especially when the grass is wet. Do not mow on wet grass. Wet grass reduces traction and steering control.

Any or all parts of the Roll-Over Protection System **MUST NOT** be removed. Failure to adhere to this guideline could result in injury or death.

WARNING

There is no roll-over protection when the roll bar is in the down position.

Lower the roll bar only when absolutely necessary.

Raise the roll bar as soon as clearance permits.

DO NOT wear the seat belt when the roll bar is in the down position.

ALWAYS wear seat belt when roll bar is in the up position.

Operate the machine smoothly, no sudden turns, starts or stops.

Check the area carefully before mowing for proper overhead clearance (i.e. branches, doorways, etc.).

DO NOT contact any overhead object with the roll bar.

Section 2

Lower the roll bar only when absolutely necessary.

1. To lower the roll bar, remove the hairpin cotter pins and remove the two (2) lock pins. See Figure 2-2.
2. Lower the roll bar to the down position.
3. To raise the roll bar, lift the bar to the upright position.
4. Install the two (2) lock pins through the hole, secure with the two (2) hairpin cotter pins. See Figure 2-2.

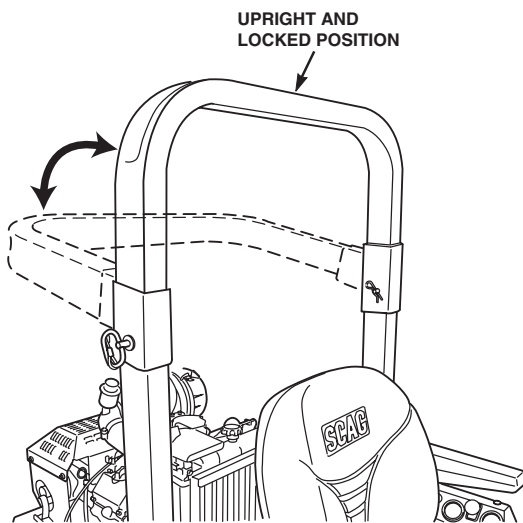

Figure 2-1. Foldable Roll-Over Protection System

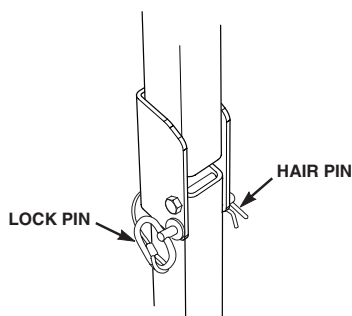

Figure 2-2. ROPS Hinge

The potential exposure of the seat belt to severe environmental conditions make it crucial to inspect the seat belt system regularly.

It is recommended that the seat belt be inspected on a daily basis for signs of damage. Any seat belt system that shows cuts, fraying, extreme or unusual wear, significant discoloration due to UV exposure, dirt or stiffness, abrasion to the seat belt webbing, or damage to the buckle, latch plate, hardware or any other obvious problem should be replaced immediately.

WARNING

Failure to properly inspect and maintain the seat belt can cause serious injury or loss of life.

1. Check the full length of the seat belt webbing for cuts, wear, fraying, dirt and stiffness. See Figure 2-3.
2. Check the seat belt webbing in areas exposed to ultra violet rays from the sun or extreme dust or dirt. If the original color of the webbing in these areas is extremely faded and/or is packed with dirt, the physical strength of this webbing may have deteriorated. If this condition exists, replace the seat belt system.
3. Check the buckle and latch for proper operation and determine if the latch plate is excessively worn, deformed, or if the buckle is damaged or cracked. See Figure 2-3.

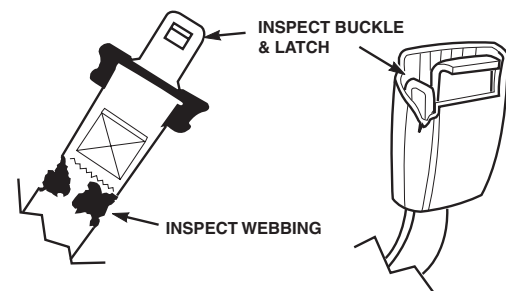

Figure 2-3. Seat Belt Inspection

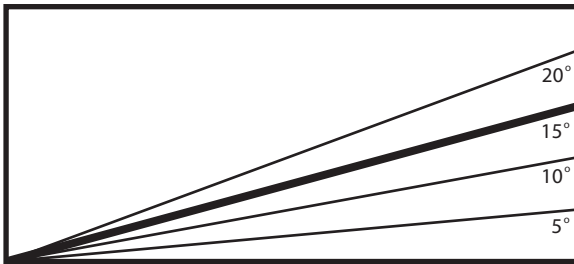

Figure 2-4. Slope Angle Graph



WARNING

Reduce speed when turning, operating on slopes, slick or wet surfaces. Allow extra distance to stop.

Stay off of slopes too steep for safe operation. To check a slope, attempt to back up it (with the cutter deck down). If the machine can not back up the slope without the wheels slipping, do not operate the machine on this slope. Under no circumstances should the machine be operated on slopes greater than 15 degrees. See Figure 2-4 to determine approximate slope.

DO NOT mow near drop-offs, ditches or embankments. The machine could suddenly roll over if a wheel goes over the edge or if the edge caves in.

Operate the machine smoothly, no sudden turns, starts or stops on a slope.

NEVER tow on slopes. The weight of the towed equipment may cause loss of traction and loss of control.

DO NOT permit untrained personnel to operate the machine.

Be cautious when loading and unloading onto trailers or trucks.

Use only a full width ramp.

Ramp angle should be no more than 15 Degrees. See Figure 2-4 to help determine approximate slope.

Back up the ramp and drive down forward.

2.6 MAINTENANCE CONSIDERATIONS & STORAGE

1. Never make adjustments to the machine with the engine running unless specifically instructed to do so. If the engine is running, keep hands, feet, and clothing away from moving parts.
2. Disengage drives, lower implement, set parking brake, stop engine and remove key or disconnect spark plug wire to prevent accidental starting of the engine when servicing or adjusting the machine. Wait for all movement to stop before adjusting, cleaning or repairing.
3. Disconnect battery or remove spark plug wire before making any repairs. Disconnect the negative terminal first and the positive last. Reconnect the positive first and the negative last.
4. Keep all nuts, bolts and screws tight, to ensure the machine is in safe working condition. Check blade mounting bolts frequently to be sure they are tight.
5. Do not change the engine governor settings or overspeed the engine. See the engine operator's manual for information on engine settings.
6. To reduce fire hazard, keep the cutting units, drives, muffler and engine free of grass, leaves, excessive grease, oil and dirt.
7. Park the machine on level ground and engage the parking brake.
8. NEVER allow untrained personnel to service the machine.
9. Use care when checking blades. Use a Blade Buddy, wrap the blade(s) or wear gloves and USE CAUTION when servicing blades. Only replace blades. NEVER straighten or weld blades.
10. Keep all parts in good working condition. Replace all worn or damaged decals.
11. Use jack stands to support components when required.
12. Carefully release pressure from components with stored energy.

 WARNING

Hydraulic fluid is under high pressure and can penetrate skin causing injury. If hydraulic fluid is injected into the skin, it must be surgically removed within a few hours by a doctor or gangrene may result.

Keep body and hands away from pinholes or nozzles that eject hydraulic fluid under high pressure. Use paper or cardboard and not hands to search for leaks.

Safely relieve all pressure from the hydraulic system by placing the control levers in the neutral lock position and shutting off the engine before performing any work on the hydraulic system.

If you need service on your hydraulic system, please see your authorized Scag dealer.

13. Let the engine cool before storing.
14. DO NOT store the machine near an open flame.
15. Shut off fuel while storing or transporting.
16. DO NOT store fuel near flames or drain indoors.
17. Charge batteries in an open, well ventilated area, away from spark and flames. Unplug charger before connecting or disconnecting from battery. Wear protective clothing and use insulated tools.

2.7 USING A SPARK ARRESTOR

The engine in this machine is not equipped with a spark arrestor muffler. It is in violation of California Public Resource Code Section 4442 to use or operate this engine on or near any forest covered, brush covered or grass covered land unless the exhaust system is equipped with a spark arrestor meeting any applicable local or state laws. Other states or federal areas may have similar laws. Check with your state or local authorities for regulations pertaining to these requirements.

2.8 SAFETY AND INSTRUCTIONAL DECALS

DANGER

SPINNING BLADES
KEEP CLEAR
BLADE CONTACT & THROWN OBJECTS CAN INJURE

483407

483407

WARNING

INSTALL BELT COVER
BEFORE OPERATING MACHINE
READ OPERATOR'S MANUAL

483402

WARNING

ROTATING BLADES AND BELTS

- Keep hands, feet & clothing clear
- Keep all guards in place
- Shut off engine & disengage blade clutch before servicing
- Use caution in directing discharge
- Read instruction manual before operating

DO NOT OPERATE UNLESS GRASS CATCHER, MULCHING KIT OR DISCHARGE CHUTE IS INSTALLED

483406

WARNING

SERIOUS INJURY OR DEATH MAY RESULT FROM MACHINE ROLLOVER

Failure to follow these instructions could result in serious injury or death

Do not operate machine on steep slopes or near drop offs. Avoid sharp and/or quick turns

Do not exceed the machine weight rating on the ROPS. Always use the seat belt

Do not jump if machine tips while ROPS is fully extended and using seat belt

If ROPS is foldable: Keep ROPS fully extended whenever possible

WHEN ROPS MUST BE DOWN
Do not use the seat belt
Drive with extra care

483300

483300

FORWARD
F

REVERSE
R

481568

WARNING

Replace seat only with Scag approved seat with seat mounting provisions and Scag approved seat belts.

Failure to follow these directions could result in injury or death in the event of a rollover.

483633

WARNING

AVOID SERIOUS INJURY OR DEATH

- Read the Operators Manual
- Solicite etiquetas en español a un distribuido Scag
- Operate only on slopes you can back up & never on slopes greater than 15 degrees
- If machine stops going up hill, stop blades and back down slowly
- Avoid sudden turns
- Do not mow when children or others around
- Never carry children even with blades off
- Look down and behind before & while backing
- Keep safety devices (guards, shields, switches, etc.) in place and working
- Remove objects that could be thrown by the blades
- Trained operators only

484321

484321

IMPORTANT

Operation on slopes can be hazardous.

This machine was originally equipped with a Rollover Protection Device with a Roll Bar and Seat Belt.

See your dealer if either is missing or damaged.

483425

483425

START/DRIVE PROCEDURE

- Engage parking brake
- Disengage mower deck drive
- Move handles to neutral position
- Start engine
- Release parking brake
- Select forward or reverse with hydro control handles

484293

DANGER

Avoid injury from burns

- Shut off engine
- Allow to cool several minutes
- Remove cap slowly
- Do not overfill

DIESEL FUEL ONLY

484292

IMPORTANT ADJUSTMENT PROCEDURES
READ OPERATORS MANUAL FOR MORE DETAILS

Check tire pressure - (Drive tires-12 psi, Caster tires-Flat Free)

HYDRAULIC FLUID LEVEL
Check hydraulic fluid level while fluid is cool. Fluid level should be 3" below top of filler neck. Fill with SAE 20w50 motor oil only.

IMPORTANT DRIVESHAFT MAINTENANCE
Grease yokes 3-4 pumps Every 200 hours
Grease spline 8-10 pumps Every 50 hours

NEUTRAL ADJUSTMENT
Loosen jam nuts
Rotate turnbuckle
With an operator in the seat, engine running, control levers in neutral and the parking brake disengaged - adjust control linkage. Loosen jam nuts. If wheel rotates forward, adjust turnbuckle CCW. If wheel rotates rearward, adjust turnbuckle CW. Adjust until drive wheel stops turning. Tighten jam nuts. Repeat for opposite side.

TRACKING ADJUSTMENT
If the machine pulls to the right, adjust LH control linkage CCW to slow left wheel. If the machine pulls to the left, adjust RH control linkage CCW to slow right wheel. Readjust neutral if necessary.

FREE WHEEL OPERATION
To move machine without running the engine, rotate both dump valves located at the LH side of the pumps CCW 1/2 turn to "Free-wheel" positions. Return dump valves to original position to operate the mower. Tighten to 7-10 ft-lbs.

484320

SPECIFICATIONS**3.1 ENGINE**

General Type	Heavy Duty Industrial/Commercial Diesel
Brand	Kubota 25HP Diesel [Spec. #D902-E2B-KAE-2 (1G447-00000)]
Model.....	Kubota - D902
Horsepower	25 HP at 3600 RPM (Model STT61V-25KBD-SS)
Type	4 Stroke Diesel, 3 Cylinder, Horizontal Shaft, Liquid-Cooled
Displacement.....	898 cc Kubota
Cylinders.....	3
Governor.....	Mechanical Type with Variable Speed Control Set At 3200 3670 RPM -Kubota
Idle Speed	1200 RPM
Fuel Pump	Injection Pump, Bosch MD Mini Type with in-line fuel filter - Kubota
Fuel.....	Diesel Fuel with a minimum cetane rating of 40
Oil Pump Group.....	Positive Displacement Gerotor™ Oil Pump with Oil Filter - Kubota
Starter.....	Electric Starting with Solenoid Shift Starter
Belts:.....	Kevlar cord. Self-adjusting, Self-tightening
Deck Drive Belt.....	Scag Part Number - 481460
Pump Drive Belt	Scag Part Number - 483678 - Kubota

3.2 ELECTRICAL

Battery	12 Volt, Maintenance Free (525CCA)
Charging System	Alternator
Charging Output	12 Volt, 40 Amp
System Polarity.....	Negative Ground
Starter.....	12 Volt Electric Ring Gear Type, Key and Solenoid Operated Interlock
Switches	Seat, Neutral Control, Mower Engagement (BBC), Parking Brake
Instrument Panel	Volt Meter, Key Switch, Throttle Lever, BBC Switch, Temperature Gauge, Fuses, Safety Start Module, Oil Pressure Gauge, Glow Plug Indicator
Fuses.....	Two (1) 20 Amp, (1) 50 Amp Resettable

3.3 POWER HEAD

Drive System	Hydraulic Drive with Two Variable Displacement Pumps and Two Cast-iron High Torque Motors
Hydrostatic Pumps	Two Hydro-Gear™ 16cc Pumps with Dump Valves for movement without running the engine and pressure relief valves
Drive Wheel Motors	Two Parker Model TG, 18 cu. Inch Cast-Iron High-Torque Motors
Steering/Travel Control	Twin Lever Fingertip Steering Control with Individual Control to Each Wheel with Gas Spring Dampers
Parking Brake	Lever Actuated Linkage to Brakes on Both Drive Wheel Axles
Wheels:	
(2) Front Caster	13 X 6.00 Flat Free
(2) Drive.....	24X12.0X12 Four-Ply Pneumatic Tubeless, Radius Edge, 61" & 72"
Tire Pressure:	
Front Caster.....	Flat Free
Drive	12 PSI
Fuel Tank	11-Gallon Seamless Polyethylene Tank with large opening and Fuel Gauge Fill Cap
Seat	Padded, Suspension Seat
Travel Speed:	
Forward	0-10
Reverse	0-6 MPH
-NOTE- The machine will travel at 10mph for transport purposes. For best cutting performance the forward travel speed should be adjusted depending upon the cutting conditions.	

3.4 CUTTER DECK

Type	Floating, Adjustable, Anti-scalping, Hybrid Design Combines Out-front and Belly-mount Designs	
Construction	10-gauge steel reinforced with 7-gauge (3/16") Support Plate. 7-gauge (3/16") deck skirt.	
True Cutting Width:		
61V	61" (155.0 cm)	
72V	72" (182.9 cm)	
Cutting Height Adjustment.....	Foot-Operated Lever Adjustment from Operator's Seat, 1.00" to 6.00" in 1/4" increments	
Cutter Blades	0.197 Thick, Milled Edge, Wear Resistant Marbain™	
61V	Three (3) 21" blades	
72V	Three (3) 24.5" blades	
Blade Engagement	Electric Blade Engagement Clutch with Control Panel Switch Connected to the Cutter Deck Gearbox through a Drive Shaft.	
Discharge Opening.....	Extra Wide 11.5" Discharge Opening with Spring Loaded Discharge Chute	
Discharge Chute.....	Black, Polypropylene (Plastic), Flexible	
Caster Wheels	13 X 6.00 Flat Free	
Spindles.....	Heavy-duty 1-1/8" Top Dimension Spindle Shaft, Cast Housing, Taper Roller Bearing, Low Maintenance with Top Access Grease Fitting and Grease Overfill Relief Poppet	
Spindle Pulleys	Split Steel with Easily Removed Taper Hubs	
Cutter Deck Belts	B-section with Kevlar Cord. Self-Adjusting, Self-Tightening	
61V	Scag Part Number - 481558	
72V	Scag Part Number - 481980	
Electric Clutch Type	Ogura Electric Clutch	
Drive Shaft.....	Clamp Yoke Shaft With Two High Speed U-Joints	

3.5 HYDRAULIC SYSTEM

Hydraulic Oil Filter	10 Micron Spin-on Element Type
Hydraulic Reservoir	Nylon; 3 Quart Capacity

3.6 WEIGHTS AND DIMENSIONS

	SMT61V	SMT72V
Length.....	87.5"	87.5"
Tracking Width	55"	55"
Overall Width w/chute down	73.5"	83"
Overall Width w/chute up.....	62"	73"
Overall Height w/ROPS up	67.5"	67.5"
Overall Height w/ROPS down.....	56.5"	56.5"
Operating Weight.....	1540#	1750#

3.7 PRODUCTIVITY

	SMT61V	SMT72V
Cutting Width	61"	72"
Acres Per Day.....	23.7	28

The preceding chart will aid you in determining how many acres your Scag mower will cut per day. The chart is an estimate based on 8 hours per day cutting time at 6 MPH with an allowance for overlap and turns.

OPERATING INSTRUCTIONS

CAUTION

Do not attempt to operate this mower unless you have read this manual. Learn the location and purpose of all controls and instruments before you operate this mower.

4.1 CONTROLS AND INSTRUMENT IDENTIFICATION

Before operating the mower, familiarize yourself with all mower and engine controls. Knowing the location, function and operation of these controls is important for safe and efficient operation of the mower.

1. **Ignition Switch (Figure 4-1).** The ignition switch is used to start the engine and has three positions; OFF, ON, and START
2. **Mower Deck Switch (Figure 4-1).** Used to engage and disengage the mower drive system. Pulling up on the switch will engage the deck drive. Pushing down on the switch will disengage the deck drive.
3. **Glow Plug Indicator (Figure 4-1).** Yellow indicator turns on when the key switch is turned to the PREHEAT position. Glow plugs must be preheated for 5 to 10 seconds before starting the engine.
4. **Engine Throttle Control (Figure 4-1).** Used to control the engine speed. Pushing the lever forward increases engine speed. Pulling the lever back decreases engine speed. Full back position is the IDLE position. Full forward is the cutting position.
5. **Voltmeter (Figure 4-1).** Indicates the condition of the charging system. When the engine is running, in normal operating conditions, the needle should be in the 12 to 14 volt range.
6. **Oil Pressure (Figure 4-1).** Indicates engine oil pressure. Reference the engine operator's manual for further information.

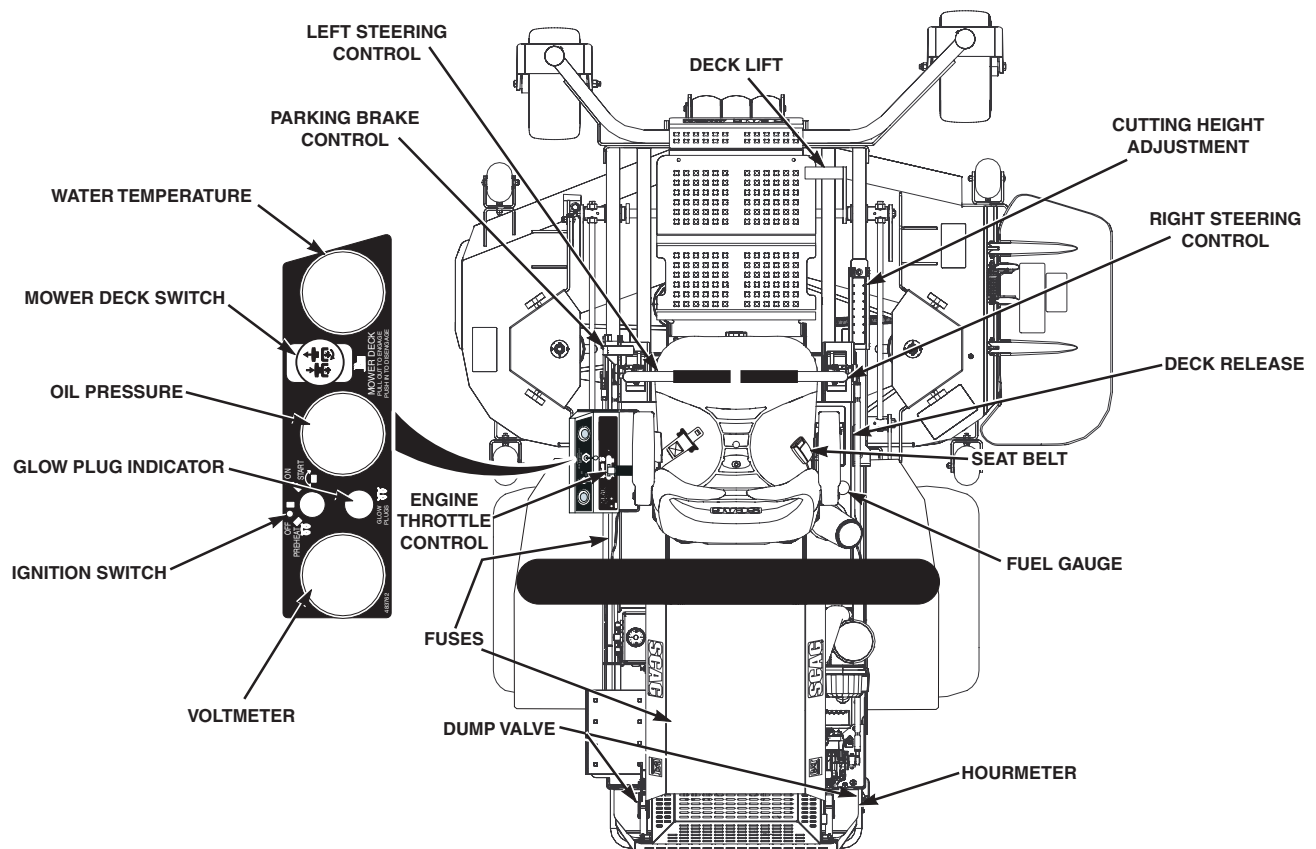

Figure 4-1. Controls and Instruments

7. **Hour meter (Figure 4-1).** Indicates the number of hours the engine has been operated. It operates whenever the key is on. Has preset maintenance reminders for engine and hydraulic system oil changes. Will start flashing scheduled maintenance 2 hours before preset time and continue flashing until 2 hours after. Automatically resets.
8. **Fuse Holders (Figure 4-1).** There is one 20-amp fuse and one 50-amp resettable fuse that protects the mower's electrical system. To replace fuse, pull fuse out of the socket and install a new fuse.
9. **Left Steering Control (Figure 4-1).** Used to control the mower's left wheel when traveling forward or reverse.
10. **Right Steering Control (Figure 4-1).** Used to control the mower's right wheel when traveling forward or reverse.
11. **Parking Brake Control (Figure 4-1).** Used to engage and disengage the parking brakes. Pull the lever back to engage the parking brakes. Push the lever forward to disengage the parking brakes.
12. **Fuel Tank Gauge (Figure 4-1).** Indicates the amount of fuel in the fuel tank.
13. **Dump Valve Control Levers (Figure 4-2).** Located on the hydraulic pumps, used to "free-wheel" the mower. Rotating the levers clockwise until they stop allows the unit to move under hydraulic power. The levers must be in this position and torqued to 10ft/lbs during operation of the mower. Rotating the levers counter-clockwise allows the mower to be moved by hand (free-wheeling).

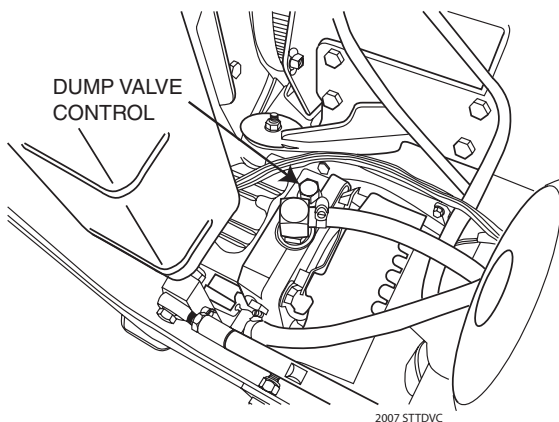

Figure 4-2. Dump Valve Control

14. **Deck Lift Foot Lever (Figure 4-1).** Used to raise

and lower the cutter deck.

15. **Cutting Height Adjustment (Figure 4-1).** Used to set the cutter deck at the desired cutting height.
16. **Deck Release Lever (Figure 4-1).** Used to lock the cutter deck in the transport position. Push the foot pedal forward and lift up on the release lever to release the cutter deck for normal mowing.
17. **Temperature Gauge (Figure 4-1).** Indicates the operating temperature of the engine.
18. **Seat Belt (Figure 4-1).** Used to secure the operator. Seat belt must be worn at all times when the ROPS is in the upright and locked position.
19. **Seat Hold Down Release Latch.** Located behind the seat. Used to secure the seat in the operator's position. Release the latch to gain access under the seat.

4.2 SAFETY INTERLOCK SYSTEM

The mower is equipped with a safety interlock system that prevents the engine from starting unless the deck drive is disengaged, the parking brake is engaged, the steering control levers are in the neutral position and the operator is in the seat. The interlock system shuts off the engine if the operator leaves the seat with the steering control levers not in the neutral position and/or the cutter blades engaged and the parking brake not engaged.

WARNING

Never operate the mower with the interlock system disconnected or malfunctioning. Do not disengage or bypass any switch; injury to yourself and others or property damage could result.

Section 4

4.3 INITIAL RUN-IN PROCEDURES (FIRST DAY OF USE OR APPROXIMATELY 10 HOURS)

1. Check all belts for proper alignment and wear at 2, 4 and 8 hours.
2. Change the engine oil and oil filter after the first 20 hours of operation. (See Section 7.4.)
3. Check hydraulic oil level in reservoir. (See Section 7.3.)
4. Check for loose hardware. Tighten as needed.
5. Check interlock system for proper operation. (See Section 4.2.)
6. Check tire pressure. Adjust pressure if necessary. (See Section 7.10)

4.4 STARTING THE ENGINE



CAUTION

DO NOT USE STARTING FLUIDS. Use of starting fluids in the air intake system may be potentially explosive or cause a “runaway” engine condition that could result in engine damage and/or personal injury.

1. Be sure the fuel shutoff valve, located behind the operator's seat, is completely open.
2. Secure the ROPS in the upright and locked position.
3. Sit in the operator's seat, fasten seat belt and place the steering control levers in the neutral position.
4. Engage the parking brake.
5. Place the PTO switch in the disengaged position.
6. Move the engine throttle control to about half engine speed.
7. Turn the ignition key to the on position until the yellow indicator for the glow plugs goes out. Then turn the ignition key to the START position and release the key as soon as the engine starts. Do not hold the key in the START position for more than 15 seconds at a time. Allow at least 60 seconds between each cranking attempt to prevent overheating of the starter motor. Prolonged cranking can damage the starter motor and shorten battery life.

8. Allow engine to warm before operating the mower.

4.5 GROUND TRAVEL AND STEERING

- IMPORTANT -

If you are not familiar with the operation of a machine with lever steering and/or hydrostatic transmissions, the steering and ground speed operations should be learned and practiced in an open area, away from buildings, fences, or obstructions. Practice until you are comfortable with the handling of the machine before attempting to mow. Learn the operation on flat ground before operating on slopes.

- IMPORTANT -

Start practicing with a slow engine speed and slow forward travel.

Learn to feather the steering controls to obtain a smooth operating action.

Practice operating the mower until you are comfortable with the controls before proceeding to mow.

FORWARD TRAVEL

To travel forward with the mower, disengage the parking brake, pull levers inward out of the neutral lock position and slowly push the steering control levers forward an equal distance. The further the steering control levers are pushed forward, the greater the forward speed will be. To increase the speed, push the steering control levers further forward and to decrease the speed, pull the steering control levers back.

To stop the forward travel, pull the steering control levers back to the neutral position.

To steer the mower left while traveling forward, pull the left steering lever back. The further the lever is pulled back, the quicker the mower will turn left.

To steer the mower right while traveling forward, pull the right steering control lever back. The further the lever is pulled back, the quicker the mower will turn right.

- NOTE -

Smooth operation of the steering levers will produce smooth mower operation. While learning the operation of the steering controls, keep the travel speed low.

- IMPORTANT -

Do not travel forward over a curb. The mower will hang up on the curb. Raise the deck and travel backwards over the curb at a 45 degree angle. (see Section 4.13 on Page 19 for cutter deck raising instructions)

REVERSE TRAVEL

⚠ CAUTION

Disengage power to the mower before backing up. Do not mow in reverse unless absolutely necessary and then only after observation of the entire area behind the mower.

⚠ CAUTION

Before backing up, observe the rear for persons and obstructions. Clear the area before backing up. Possible injury or property damage could occur.

To travel in reverse, pull levers inward out of the neutral lock position and pull both handles back. Keep the travel speed low while traveling in reverse.

- NOTE -

The mower may not travel straight in reverse. Slight adjustments may need to be made using the steering controls.

To steer left while traveling in reverse, allow the left steering control lever to move forward. The further the control is allowed to move forward, the quicker the mower will turn left.

To steer right while traveling in reverse, allow the right steering control lever to move forward. The further the control is allowed to move forward, the quicker the mower will turn right.

To stop the reverse travel, allow the steering control levers to return to the neutral position. If the mower is to be parked, place the handles in the neutral lock position and engage the parking brake.

4.6 ENGAGING THE DECK DRIVE (CUTTER BLADES)

1. Set the throttle at about 3/4 speed. Do not attempt to engage the deck drive at high speed as this shortens the electric clutch life — use only moderate engine speed when engaging the deck drive.
2. Engage the deck drive by pulling out on the yellow switch, located on the instrument panel, (Figure 4-3) to the engage position.

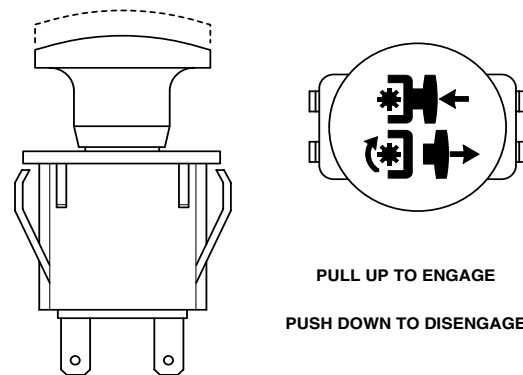

390S01c

Figure 4-3. Cutter Engage Switch

- NOTE -

A squealing noise may be heard when engaging or disengaging the deck drive. It is caused by the electric clutch plates meshing as the mower comes up to speed.

3. To disengage the deck drive, push the switch in to the disengage position.
4. Always operate the engine at full throttle to properly maintain cutting speed. If the engine starts to lug down, reduce the forward speed and allow the engine to operate at maximum RPM.

Section 4

4.7 HILLSIDE OPERATION

WARNING

DO NOT operate on steep slopes. To check a slope, attempt to back up it (with the cutter deck down). If the machine can back up the slope without the wheels slipping, reduce speed and use extreme caution. Under no circumstances should the machine be operated on slopes greater than 15 degrees. See Figure 2-4, Page 8 to help determine approximate slope of area to be mowed. ALWAYS FOLLOW OSHA APPROVED OPERATION.

1. This mower has been designed for good traction and stability under normal mowing conditions. However, caution must be used when traveling on slopes, especially when the grass is wet. Wet grass reduces traction and steering control. The Roll-Over Protection System is standard equipment for this machine. See Section 2.5, page 6 of this manual for further details.
2. Stay two cut widths away from slopes, drop offs, ditches and retaining walls.
3. To prevent tipping or loss of control, do not start or stop suddenly, avoid unnecessary turns and travel at reduced speed. If tires lose traction, disengage blades and proceed slowly off the slope.
4. Avoid sudden starts when mowing uphill. Sudden starts may cause the machine to tip backwards.
5. Loss of traction may occur when traveling down hill. Weight transfers to the front of the machine and may cause the drive wheels to slip causing loss of braking or steering.
6. Keep tires properly inflated.

4.8 PARKING THE MOWER

1. Park the machine on a flat, level surface only. Do not park the machine on an incline.
2. Place the steering control levers in the neutral position.
3. Disengage the cutter blades.
4. Slow the engine to idle speed.
5. Engage the parking brake.
6. Turn the ignition key to the OFF position and remove the key.

4.9 AFTER OPERATION

1. Wash the entire mower after each use. Do not use high pressure spray or direct the spray onto electrical components.

- IMPORTANT -

Do not wash a hot or running engine. Cold water will damage the engine. Use compressed air to clean the engine if it is hot.

2. Keep the entire mower clean to inhibit serious heat damage to the engine or hydraulic oil circuit.
3. Check the drive belts for proper alignment and any signs of wear. Correct and adjust if necessary.

DANGER

To avoid injury from burns, allow the mower to cool before removing the fuel tank cap and refueling.

4. After the mower has cooled down, fill the fuel tank with fresh, clean fuel with a minimum cetane rating of 40 at the end of every day of operation.
5. Check the tire pressure. Adjust pressure if necessary.

4.10 REMOVING CLOGGED MATERIAL

DANGER

ROTATING BLADES

NEVER PUT YOUR HANDS INTO THE DISCHARGE CHUTE FOR ANY REASON!

Shut off the engine and remove the key and only then use a stick or similar object to remove material if clogging has occurred.

1. If the discharge chute becomes clogged, shut off the engine and remove the ignition key. Using a stick or similar item, dislodge the clogged material. Then resume normal mowing.

4.11 MOVING MOWER WITH ENGINE STOPPED

To “free-wheel” or move the mower around without the engine running, rotate the dump valve levers counter-clockwise. See Figure 4-4. Disengage the parking brake and move the mower by hand. When the machine is in the desired position, engage the parking brake and rotate the levers clockwise until they stop. The dump valve levers must be returned to the DRIVE position and torqued to 10 lb-ft to drive the mower.

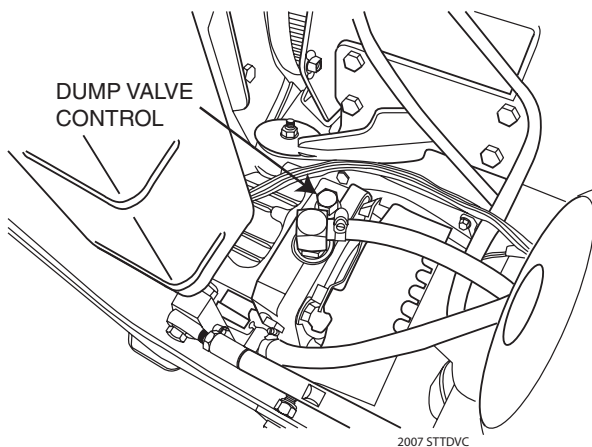

Figure 4-4. Dump Valve Control

4.12 RECOMMENDATIONS FOR MOWING

1. Do not mow with dull blades. A dull blade will tear grass, resulting in poor lawn appearance and reduced mowing power.

⚠ WARNING

DO NOT operate without Discharge Chute, Mulching Kit, or entire Grass Catcher properly installed.

2. The discharge chute must not be removed and must be kept in the lowest position to deflect grass clippings and thrown objects downward. Direct the side discharge away from sidewalks or streets to minimize cleanup of clippings. When mowing close to obstacles, direct the discharge away from the obstacles to reduce the chance of property damage by thrown objects.

3. Cut grass when it is dry and not too tall. Do not cut grass too short (cut off 1/3 or less of existing grass for best appearance). Mow frequently.
4. Keep mower and discharge chute clean.
5. When mowing wet or tall grass, mow the grass twice. Raise the mower to the highest setting for the first pass and then make a second pass to the desired height.
6. Use a slow travel speed for trimming purposes.
7. Operate the engine at full throttle for best cutting. Mowing with a lower RPM causes the mower to tear the grass. The engine is designed to be operated at full speed.
8. Use the alternate stripe pattern for best lawn appearance. Vary the direction of the stripe each time the grass is mowed to avoid wear patterns in the grass.

Section 4

4.13 ADJUSTING CUTTING HEIGHT

The mower deck can be adjusted from a height of 1.0 inch to 6.0 inches at 1/4-inch intervals. To adjust the cutting height:

WARNING

DO NOT adjust the cutting height with the mower blades rotating. Disengage the power to the cutter blades and then adjust cutting height.

1. Disengage the power to the cutter blades.
2. Push the cutting height adjustment foot pedal all the way forward using your right foot until it locks in place. See Figure 4-5.

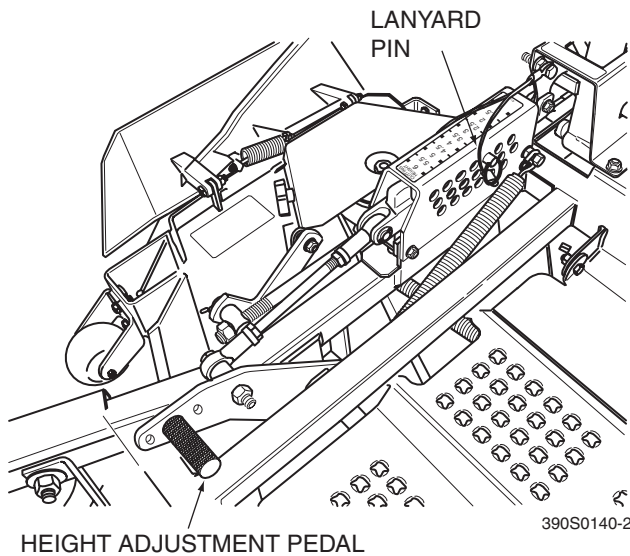

Figure 4-5. Adjusting Cutting Height

3. Insert the lanyard pin into the cutting height index at the desired cutting height. Push forward on the deck lift foot lever, hold in place and pull back on the deck release lever. See Figure 4-6. Slowly release the foot pedal. A deck height decal is located on the cutting height index as an aid in adjusting the deck to the desired height. See Figure 4-5.

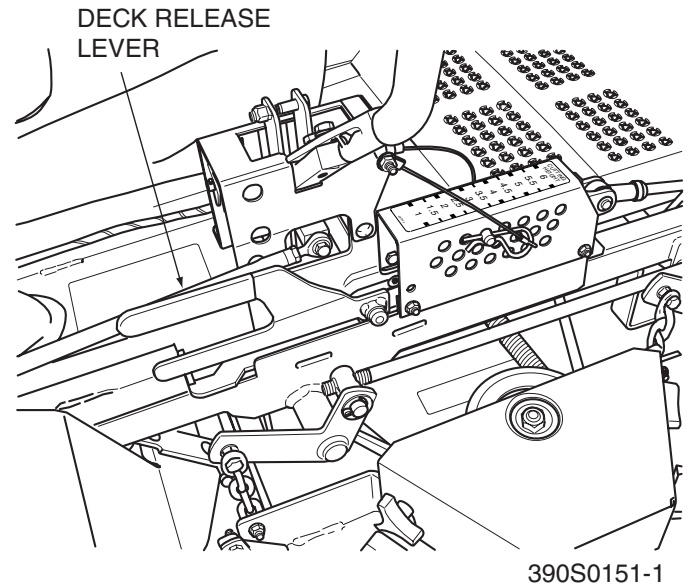

Figure 4-6. Deck Release Lever

4.14 ADJUSTING THE HEIGHT ADJUST PEDAL

1. Position the seat to the desired location.
2. While in the operator's position without the engine running, push down on the height adjust pedal to check for full function control.
3. The height adjust pedal can be located in three (3) different positions for operator comfort and control. See Figure 4-7.

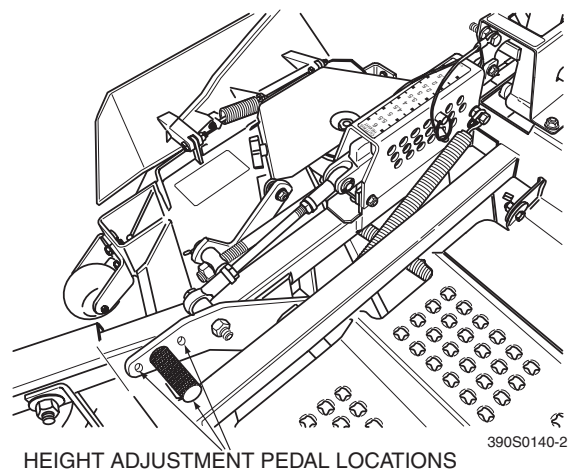

Figure 4-7. Height Adjust Pedal Locations

4.15 ADJUSTING THE STEERING LEVERS

1. Position the seat to the desired location.
2. While in the operator's position with out the engine running, move both steering levers forward and reverse to check for full function control and comfort.
3. If adjustment of the steering levers is needed, use the following instructions to adjust.
 - A. Loosen the tension knob on the lever assembly.
 - B. Rotate the steering lever forward or backward to achieve the optimum operating position.
 - C. Tighten the tension knob and repeat on the opposite side.
 - D. While in the operator's position, bring the steering levers out of the neutral lock position and check to make sure both levers are even before operating.

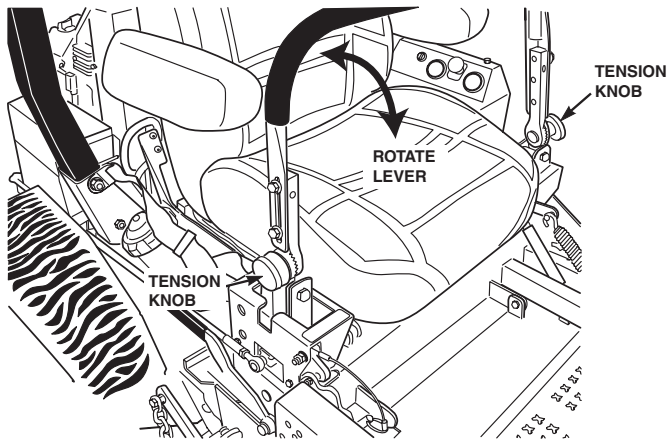

Figure 4-8. Adjusting Steering Levers

4. The control handle can also be adjusted in two different positions. If necessary, remove the two bolts securing the control handle to the control lever. Install the handle in the desired position.

4.16 TOWING (OPTIONAL HITCH ACCESSORY)

1. NEVER allow children or others in or on towed equipment.
2. Tow only with a machine that has a hitch designed for towing. Do not attach towed equipment except at the hitch point.
3. Follow manufacturer's recommendations for weight limit for towed equipment. 250/lbs. maximum towing weight.
4. NEVER tow on slopes. The weight of the towed equipment may cause loss of traction and loss of control.
5. Travel slowly and allow extra distance to stop.
6. Zero-turning with a trailer attached could cause damage to the trailer or mower.

TROUBLESHOOTING CUTTING CONDITIONS

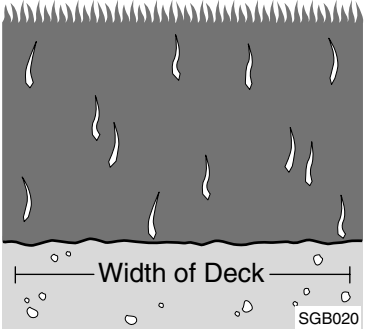
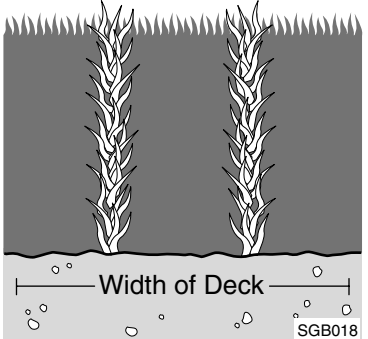
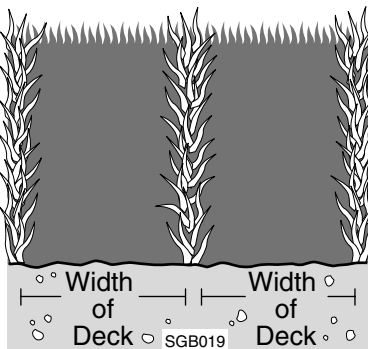
CONDITION	CAUSE	CURE
<p>STRINGERS - OCCASIONAL BLADES OF UNCUT GRASS</p>  <p style="text-align: right;">SGB020</p>	Low engine RPM	Run engine at full RPM
	Ground speed too fast	Slow speed to adjust for conditions
	Wet grass	Cut grass after it has dried out
	Dull blades, incorrect sharpening	Sharpen blades
	Deck plugged, grass accumulation	Clean underside of deck
	Belts slipping	Adjust belt tension
<p>STREAKING - STRIPS OF UNCUT GRASS IN CUTTING PATH</p>  <p style="text-align: right;">SGB018</p>	Dull, worn blades	Sharpen blades
	Incorrect blade sharpening	Sharpen blades
	Low engine RPM	Run engine at full RPM
	Belt slipping	Adjust belt tension
	Deck plugged, grass accumulation	Clean underside of deck
	Ground speed too fast	Slow speed to adjust for conditions
	Wet grass	Cut grass after it has dried out
	Bent blades	Replace blades
<p>STREAKING - STRIPS OF UNCUT GRASS BETWEEN CUTTING PATHS</p>  <p style="text-align: center;">SGB019</p>	Not enough overlapping between rows	Increase the overlap of each pass

TROUBLESHOOTING CUTTING CONDITIONS (CONT'D)

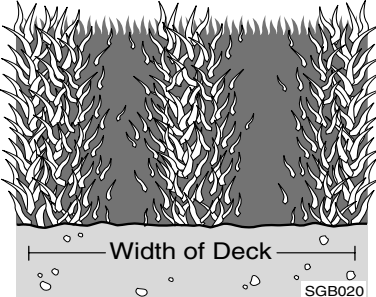
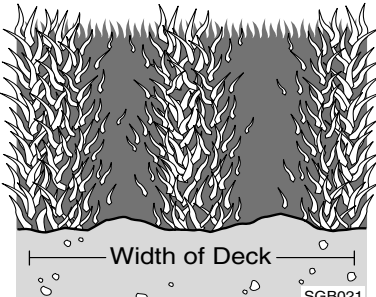
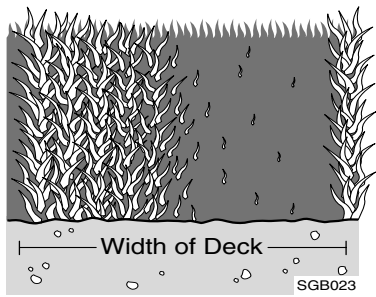
CONDITION	CAUSE	CURE
<p>UNEVEN CUT ON FLAT GROUND - WAVY HIGH-LOW APPEARANCE, SCALLOPED CUT, OR ROUGH CONTOUR</p>  <p style="text-align: right; font-size: small;">SGB020</p>	Lift worn from blade	Replace blade
	Blade upside down	Mount with cutting edge toward ground
	Deck plugged, grass accumulation	Clean underside of deck
	Too much blade angle (deck pitch)	Adjust pitch and level
	Deck mounted improperly	See your authorized SCAG dealer
	Bent spindle area	See your authorized SCAG dealer
	Dull blade	Sharpen blade
<p>UNEVEN CUT ON UNEVEN GROUND-WAVY APPEARANCE, HIGH-LOW SCALLOPED CUT, OR ROUGH CONTOUR</p>  <p style="text-align: right; font-size: small;">SGB021</p>	Uneven ground	May need to reduce ground speed, raise cutting height, and/or change direction of cut
<p>SLOPING RIDGE ACROSS WIDTH OF CUTTING PATH</p>  <p style="text-align: right; font-size: small;">SGB023</p>	Tire pressures not equal	Check and adjust tire pressure
	Wheels uneven	Check and adjust tire pressure
	Deck mounted incorrectly	See your authorized SCAG dealer
	Deck not level side-to-side	Check for level and correct

TROUBLESHOOTING CUTTING CONDITIONS (CONT'D)

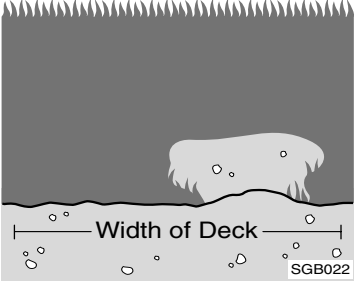
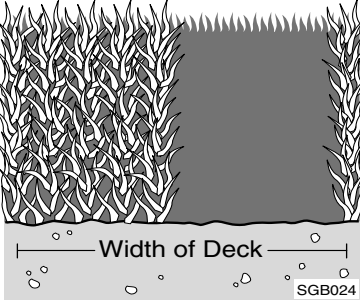
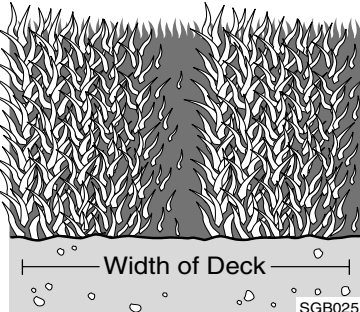
CONDITION	CAUSE	CURE
<p>SCALPING - BLADES HITTING DIRT OR CUTTING VERY CLOSE TO THE GROUND</p>  <p>Width of Deck SGB022</p>	Low tire pressures	Check and adjust pressures
	Ground speed too fast	Slow speed to adjust for conditions
	Cutting too low	May need to reduce ground speed, raise cutting height, change direction of cut, and/or change pitch and level
	Rough terrain	May need to reduce ground speed, raise cutting height, and/or change direction of cut
	Ground speed too fast	Slow speed to adjust for conditions
	Wet grass	Cut grass after it has dried out
<p>STEP CUT - RIDGE IN CENTER OF CUTTING PATH</p>  <p>Width of Deck SGB024</p>	Blades not mounted evenly	Adjust pitch and level
	Bent blade	Replace blade
	Internal spindle failure	See your authorized SCAG dealer
	Mounting of spindle incorrect	See your authorized SCAG dealer
<p>SLOPE CUT - SLOPING RIDGES ACROSS WIDTH OF CUTTING PATH</p>  <p>Width of Deck SGB025</p>	Bent spindle mounting area	See your authorized SCAG dealer
	Internal spindle failure	See your authorized SCAG dealer
	Bent deck housing	See your authorized SCAG dealer

ADJUSTMENTS

6.1 PARKING BRAKE ADJUSTMENT

WARNING

Do not operate the mower if the parking brake is not operable. Possible severe injury could result.

The parking brake linkage should be adjusted whenever the parking brake lever is placed in the “ENGAGE” position and the parking brake will allow the mower to move. If the following procedures do not allow you to engage the parking brake properly, contact your Scag dealer for further brake adjustments.

1. Position a floor jack under the rear of the machine. Raise the machine and support it to prevent it from falling. Block the caster wheels to prevent the machine from moving. Remove the drive wheels.
2. With the brake lever in the disengaged position, check the distance between the top of the frame tube and the bottom of the brake handle. The distance should be 2" to 2-1/4" (See Figure 6-1).
3. If the distance is not at the specified measurement, adjust by loosening the jam nuts at both ends of the brake control rod and turning the rod until the proper distance is achieved. (See Figure 6-1). Tighten the jam nuts.
4. With the brake in the engaged position, check the spring compression between the two flat washers on the LH side of the machine. The distance should be 1-7/16". (See Figure 6-2).
5. If the distance is not at the specified measurement, loosen the jam nut at the rod end side of the brake actuator rod. (See Figure 6-2).
6. Turn the adjustment bolt (clockwise to decrease the spring compression or counter clockwise to increase the spring compression) until the 1-7/16" measurement is achieved and tighten the jam nut. (See Figure 6-2).
7. Repeat steps 4 though 6 on the RH side of the machine.
8. Replace the drive wheels and test the brake.

- NOTE -

If this procedure does not achieve proper brake adjustment, please contact your authorized Scag dealer.

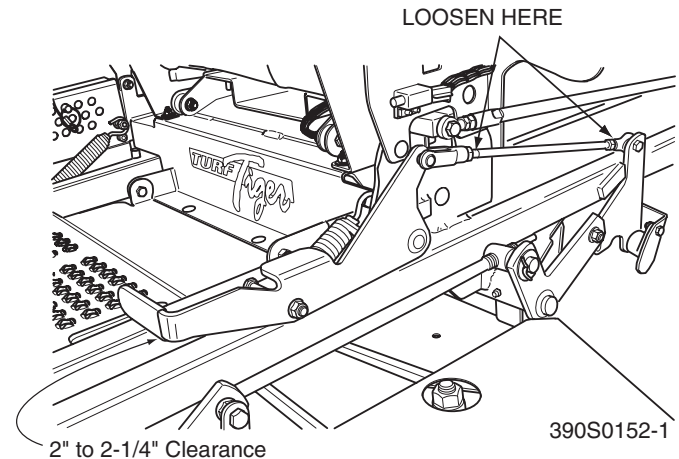

Figure 6-1. Brake Adjustment

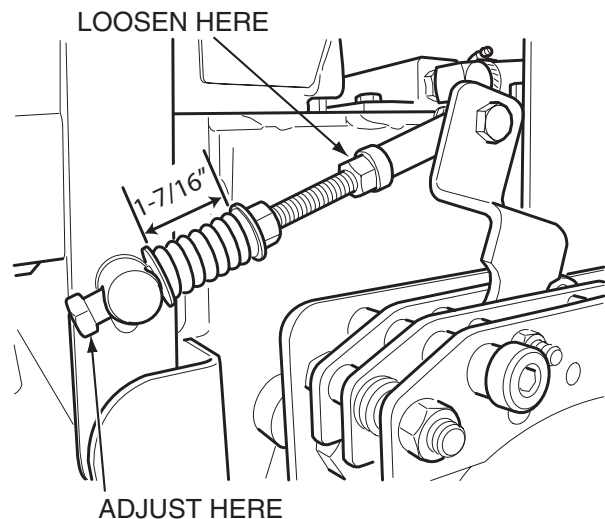

Figure 6-2. Brake Rod Adjustment

Section 6

6.2 TRAVEL ADJUSTMENTS

Neutral or tracking adjustments will need to be made if:

- A. The steering control levers are in the neutral position and the machine creeps forward or backward. (Neutral Adjustment, See Below).
- B. The steering control levers are in the full forward position and the mower pulls to one side or the other when traveling in a forward direction. (Tracking Adjustment, See Page 26).

NEUTRAL ADJUSTMENT

1. Be sure the dump valve levers are in the run position and the steering control levers are in the neutral lock position.
2. With an operator in the seat, start the engine and disengage the parking brake.
3. Run the engine at full operating speed and check if the machine creeps forward or backwards.
4. Adjust the RH wheel by loosening the jam nuts on the steering control rod and turning the rod until the drive wheel turns in the forward direction. Turn the rod back until the drive wheel stops moving. Turn the rod an additional 1/2 turn. (See Figure 6-3).

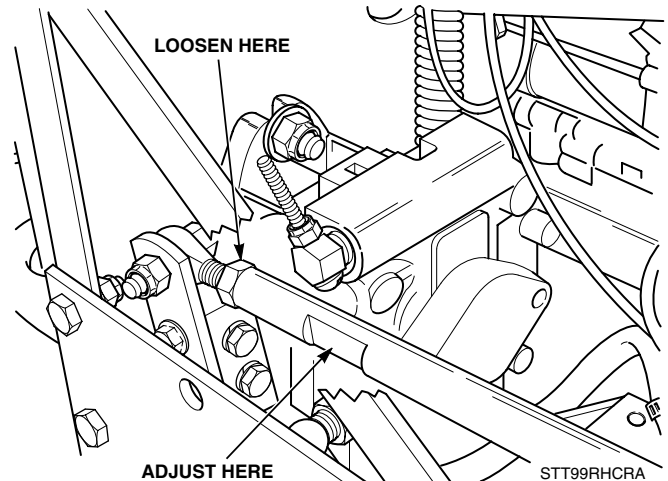
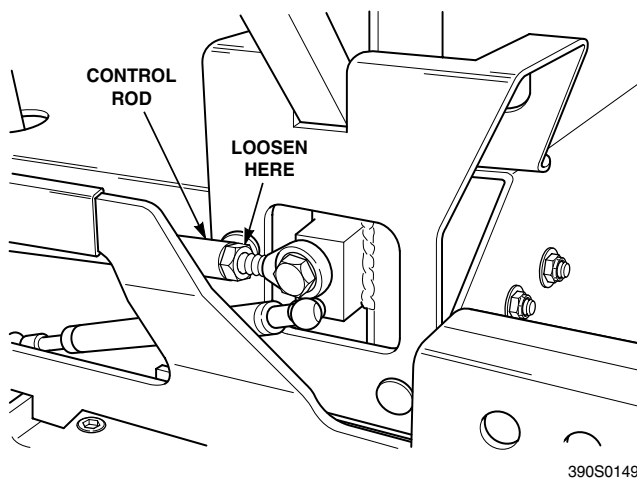

Figure 6-3. RH Steering Control Rod Adjustment

5. Tighten the jam nuts and repeat for the LH wheel. (See Figure 6-4).

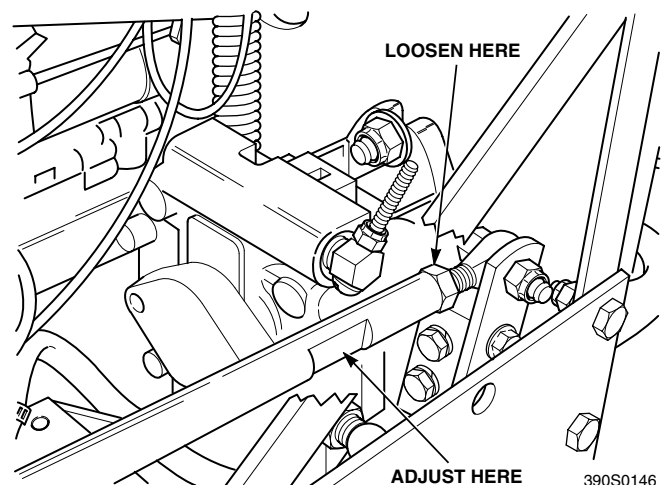
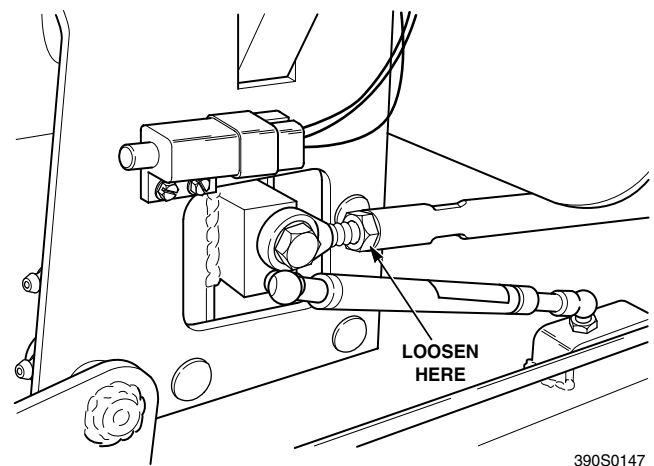

Figure 6-4. LH Steering Control Rod Adjustment

6. Actuate the steering control levers forward and reverse several times and return them to the neutral position.
7. Check that the drive wheels remained in neutral and readjust if necessary.
8. Check that the steering control levers hit the stop before the pumps reach full stroke. Adjust as needed.

TRACKING ADJUSTMENT

CAUTION

Stop the engine and remove the key from the ignition before making any adjustments. Wait for all moving parts to come to a complete stop before beginning work.

CAUTION

The engine and drive unit can get hot during operation causing burn injuries. Allow engine and drive components to cool before making any adjustments.

- NOTE -

Before proceeding with this adjustment, be sure that the caster wheels turn plus pivot freely and that the tire pressure in the drive wheels is correct. If the tire pressure is not correct, the machine will pull to the side with the lower pressure.

1. If at full speed the mower pulls right, it is an indication that the left wheel is turning faster than the right wheel. To adjust this condition, proceed as follows:
 - A. Stop the machine and place the steering control levers in the neutral position. Loosen the lock nuts securing the ball joints at each end of the LH steering control rod. Rotate the control rod to lengthen the rod and tighten the lock nuts. This will cause the control rod to stroke the LH pump less, slowing down the LH wheel. (See Figure 6-4, page 25)

- NOTE -

If after making the adjustment as outlined in step 1A, the machine creeps forward or backward, the neutral adjustment must be made as described on page 25.

2. If at full speed the mower pulls left, it is an indication that the right wheel is turning faster than the left wheel. To adjust this condition, proceed as follows:

- A. Stop the machine and place the steering control levers in the neutral position. Loosen the lock nuts securing the ball joints at each end of the RH steering control rod. Rotate the control rod to lengthen the rod and tighten the lock nuts. This will cause the control rod to stroke the RH pump less, slowing down the RH wheel. (See Figure 6-3, page 25)

- NOTE -

If after making the adjustment as outlined in step 2A, the machine creeps forward or backward, the neutral adjustment must be made as described on page 25.

6.3 THROTTLE CONTROL ADJUSTMENTS

This adjustment must be performed by your Scag dealer to ensure proper and efficient running of the engine. Should the throttle control need adjustment, contact your authorized Scag service center.

6.4 BELT ADJUSTMENT

WARNING

Before removing any guards, shut the engine off and remove the ignition key.

All drive belts and cutter deck belts are spring loaded and self tensioning, however after the first 2, 4, 8 and 10 hours of operation, the belts should be checked for proper alignment and wear. Thereafter, check the belts after every 40 hours of operation or weekly, whichever occurs first.

WARNING

If the pump drive belt fails, steering control will be lost which could result in serious injury or death. Replace the pump drive belt as needed or every 400 hours / 2 years, whichever occurs first.

6.5 BELT ALIGNMENT

Belt alignment is important for proper performance of your Scag mower. If you experience frequent belt wear or breakage, see your authorized Scag service center for belt adjustment.

6.6 CUTTER DECK ADJUSTMENTS

Cutter deck level, pitch and height are set at the factory. However, if these adjustments should ever need to be made, the following procedures will aid in obtaining the proper cutter deck adjustment.

- NOTE -

Before proceeding with the cutter deck adjustments, be sure that all tires are properly inflated.

CUTTER DECK LEVEL

The cutter deck should be level from side-to-side for proper cutting performance. To check for level, be sure that the mower is on a flat, level surface, the tires are properly inflated and the cutter deck is set at the most common cutting height that you will use. On the RH side of the machine, check the distance from the top of the cutter deck to the floor. Next check the distance from the top of the cutter deck to the floor on the LH side of the machine. Both measurements should be the same. If the two measurements are different, the cutter deck level must be adjusted as follows:

1. On the front LH side of the cutter deck locate the cutter deck level adjusting bracket (See Figure 6.5)

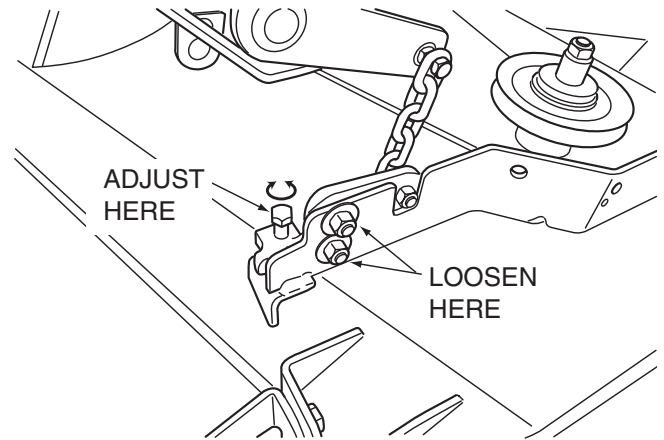

Figure 6-5. Cutter Deck Level Adjustment

2. Loosen the two (2) elastic stop nuts. Adjust the bolt up or down on the adjustment bracket to adjust the cutter deck until the distance from the top of the cutter deck to the floor is the same as the measurement on the RH side of the machine.
3. Tighten the two elastic stop nuts to secure the cutter deck in the proper position.

CUTTER DECK PITCH

The pitch of the cutter deck should be equal between the front and rear of the cutter deck for proper cutting performance. To check for proper deck pitch, be sure that the mower is on a flat, level surface and the tires are properly inflated.

Check the distance from the top of the cutter deck to the floor at the rear RH side of the cutter deck directly behind the cutter deck hanging chains. Next check the distance from the top of the cutter deck to the floor at the front RH side of the cutter deck directly in front of the cutter deck hanging chains. The measurement at the front of the cutter deck should be equal to the measurement at the rear of the deck. Make these measurements at the LH side of the cutter deck also. If the measurement at the front of the deck is not equal, the cutter deck pitch must be adjusted as follows

1. Loosen the jam nut on both adjusting rods. (See Figure 6.6)

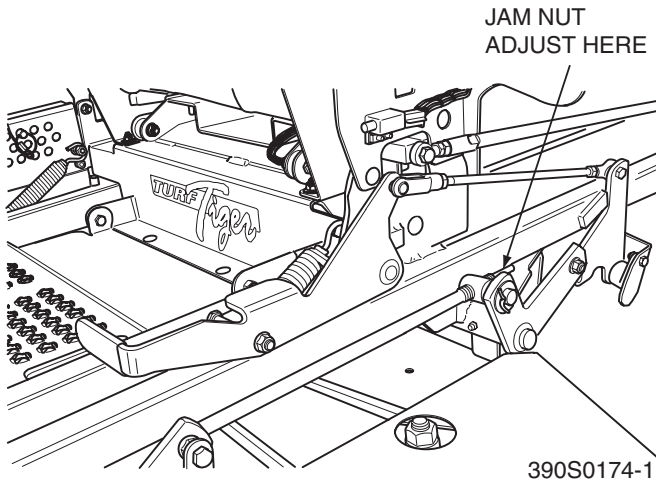

Figure 6-6. Cutter Deck Level Adjustment

- Using a wrench on the jam nut (See Figure 6.6) turn the adjusting rods until the proper pitch is obtained on both the RH and the LH side of the cutter deck. Tighten both jam nuts.

- NOTE -

To prevent the cutter deck from teetering, all four (4) cutter deck hanging chains must have tension on them. If all four chains do not have tension on them and the deck teeters, you must readjust the cutter deck as outlined in the procedures above. All measurements should be taken from the top edge of the deck as the Velocity Plus decks have an uneven bottom edge.

CUTTER DECK HEIGHT

The cutter deck height adjustment is made to ensure that the cutter deck is cutting at the height indicated on the cutting height index gauge. To check for proper deck height, be sure that the mower is on a flat, level surface and the tires are properly inflated.

- Place the cutter deck in the transport position. Loosen the jam nuts on both ends of the deck height control rod. (See Figure 6.7)

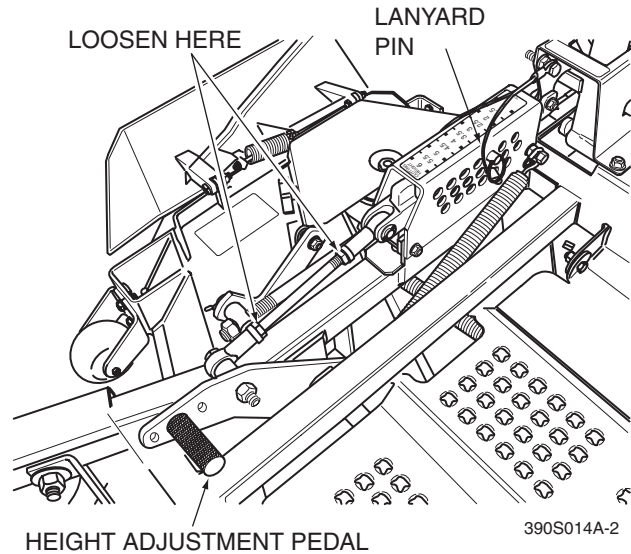

Figure 6-7. Cutter Deck Height Adjustment

- Turn the control rod (See Figure 6.7) until there is a 1/4" space between the rear deck stop and the top of the cutter deck. (See Figure 6.8). Tighten the jam nuts on the control rod.

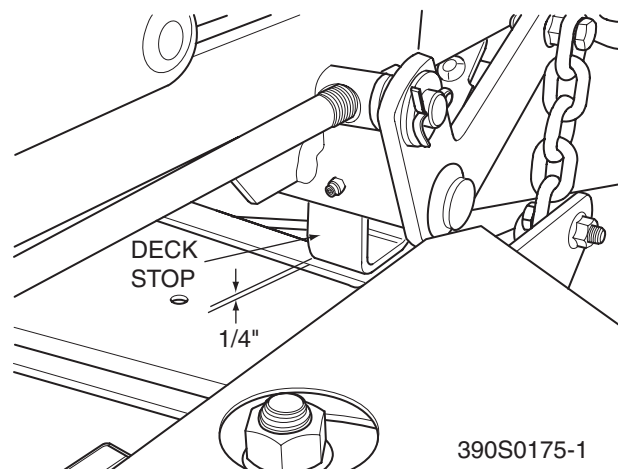

Figure 6-8. Cutter Deck Stop

- Check the cutter deck cutting height by placing the lanyard pin in the 3" position on the cutting height index. Release the deck from the transport position and allow the deck to move to the 3" cutting height position.
- Check the measurement from the floor to the cutter blade tip. If the measurement is not at 3", an adjustment can be made using the deck height control rod. (See Figure 6.7)

- NOTE -

If an adjustment had to be made, be sure that the cutter deck can easily be locked into the transport position.

C. 4-3/4" or 5-1/4" Position - (See Figure 6-9). Placing the baffle in either the 4-3/4" or 5-1/4" setting will enhance fall cutting (leaf pickup) and reduce cutter deck "blowout".

CUSTOM-CUT BAFFLE ADJUSTMENT

The Custom-Cut Baffle is designed to deliver optimum airflow and superior cutting performance in any type of grass. The Custom-Cut Baffle can be raised or lowered to precisely tailor the deck's performance for the type of grass being cut. The baffle can be set in seven (7) different positions for optimum performance.

A. 3-1/2" or 3-3/4" Position - (See Figure 6-9). For very tall, wiry or tough-to-cut grass.

B. 4" (factory setting), 4-1/4" or 4-1/2" Position - (See Figure 6-9). For general purpose cutting. This gives the best mix of cutting performance in all types of grass.

To adjust the Custom-Cut Baffle height:

1. Place the cutter deck in the transport position.
2. Remove the hardware securing the Custom-Cut Baffle to the cutter deck.

- NOTE -

Hardware location used in the illustrations are for reference only. Location of hardware may vary depending on cutter deck size.

3. Move the Custom-Cut Baffle to desired position. (See Figures 6-9).
4. Reinstall the mounting hardware. Torque hardware to 39 ft-lbs.

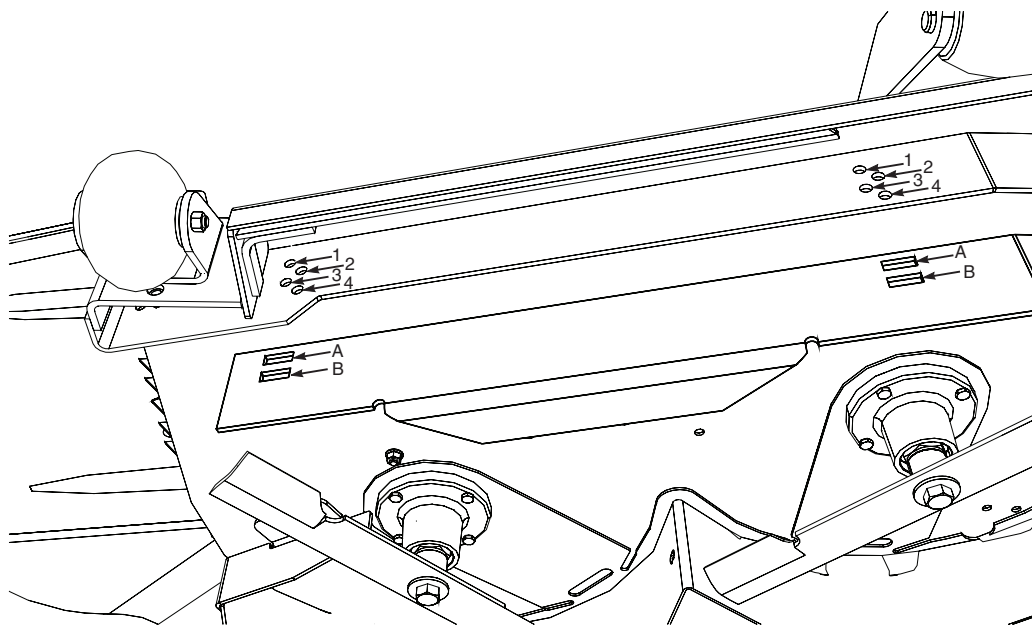

Custom-Cut Baffle Adjustment

Mounting Slot Selected	Mounting Hardware Location			
Slot "A"	Hole 1	Hole 2	Hole 3	Hole 4
Height (inches)	3-3/4"	4-1/4"	4-3/4"	5-1/4"
Slot "B"		Hole 2	Hole 3	Hole 4
Height (inches)		3-1/2"	4"	4-1/2"

Figure 6-9. Custom-Cut Baffle Adjustment

6.7 ELECTRIC CLUTCH ADJUSTMENT

The electric clutch serves two functions in the operation of the mower. In addition to starting and stopping the power flow to the cutter blades, the clutch also acts as a brake to assist in stopping blade rotation when the PTO is switched off or the operator presence circuit is interrupted.

When the clutch is disengaged, the air gap between the armature and rotor must be adjusted to fifteen thousandths of an inch, 0.015, for proper operation. The airgap adjustment is made at three bolts on the clutch. There are three inspection windows, one next to each adjusting bolt. See Figure 6-10.

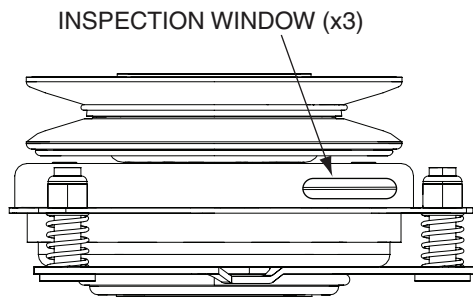

Figure 6-10. Clutch Air Gap Adjustment

1. Locate the inspection windows on the clutch.
2. Place a 0.015 feeler gauge in the slot between the rotor and the armature.
3. Tighten or loosen the adjusting bolt as needed to achieve the 0.015 inch airgap. See Figure 6-11. Perform this operation at all three inspection windows.

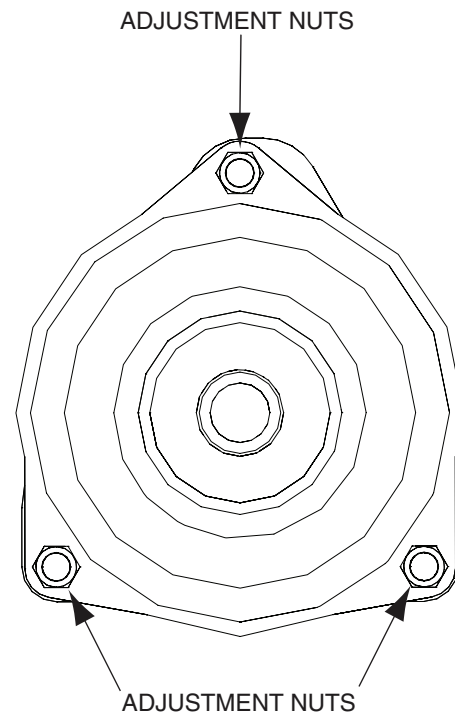

Figure 6-11. Clutch Air Gap Adjustment

This adjustment should be done every 500 hours of operation or annually, whichever comes first. In cases where the machine is heavily used, airgap settings should be checked more often.

If the air gap is too narrow, the clutch armature may drag when disengaged, resulting in premature failure.

If the air gap is too wide, the clutch may be slow to engage as the magnet must pull the armature in from a greater distance.

MAINTENANCE

7.1 MAINTENANCE CHART - RECOMMENDED SERVICE INTERVALS

BREAK-IN (FIRST 10)	HOURS						PROCEDURE	COMMENTS
	8	20	40	100	200	500		
X							Check all hardware for tightness	
X							Check hydraulic oil level	See paragraph 7.3
X							Check all belts for proper alignment	See paragraph 7.8
X							Check coolant level	See paragraph 7.12
	X						Check hydraulic fittings and hoses for leaks	Use extreme caution when checking the hydraulic hoses. See paragraph 2.6
	X						Check engine oil level	See paragraph 7.4
	X						*Clean mower	See paragraph 7.13
	X						Check condition of blades	See paragraph 7.9
	X						Apply grease to fittings	See paragraph 7.2
	X						Check tire pressure	See paragraph 7.10
	X						Inspect seat belt for wear or damage	See paragraph 2.5
	X						Check the operator interlock system	See paragraph 4.2
	X						Check coolant level	See paragraph 7.12
		X					Change engine oil and filter	See paragraph 7.4
			X				Check battery electrolyte level clean battery posts and cables	See paragraph 7.7
			X				Inspect pump drive belt. Replace every 400 hours or 2 years, whichever occurs first	See paragraph 6.4 & 7.8
			X				Check belts for proper alignment	See paragraph 7.8
				X			Apply grease to fittings	See paragraph 7.2
				X			Change engine oil	See paragraph 7.4
				X			*Clean air cleaner element	See paragraph 7.6
				X			Check lubricant in cutter deck gearbox	See paragraph 7.11
				X			Check condition of fuel lines	

* Perform these maintenance procedures more frequently under extreme dusty or dirty conditions

MAINTENANCE CHART - RECOMMENDED SERVICE INTERVALS (CONT'D)

BREAK-IN (FIRST 10)	HOURS					PROCEDURE	COMMENTS
	8	40	100	200	500		
				X		Apply grease to fittings	See paragraph 7.2
				X		Check hardware for tightness	
				X		Change engine oil filter	See paragraph 7.4
				X		Check hydraulic oil level	See paragraph 7.3
					X	Replace engine fuel filter	See paragraph 7.5
					X	Drain hydraulic system and replace hydraulic oil	Use SAE 20W50 Motor Oil. See paragraph 7.3
					X	Replace hydraulic oil filter	See paragraph 7.3
					X	Replace cutter deck gearbox lubricant	See paragraph 7.11
					X	Change coolant	See paragraph 7.12

7.2 LUBRICATION

GREASE FITTING LUBRICATION CHART (SEE FIGURE 7-1)

LOCATION	LUBRICATION INTERVAL	LUBRICANT	NO. OF PLACES
1 Caster Wheel Pivot *	500 Hours/Yearly	Chassis Grease	2
2 Caster Wheel Bearings	100 Hours/Monthly	Chassis Grease	2
3 Brake Actuator	200 Hours/Monthly	Chassis Grease	2
4 Cutter Deck Bellcranks	100 Hours/Bi-Weekly	Chassis Grease	4
5 Cutter Deck Pusharms	100 Hours/Bi-Weekly	Chassis Grease	2
6 PTO Spindle	40 Hours/Weekly	+Lithium MP White Grease 2125	1
7 Cutter Deck Spindle	40 Hours/Weekly	+Lithium MP White Grease 2125	3
8 Brake Handle	200 Hours/Monthly	Chassis Grease	1
9 Cutter Deck Drive Shaft U-Joints	200 Hours/Monthly	Chassis Grease	2
10 Cutter Deck Drive Shaft Slip Sleeve	40 Hours/Weekly	Chassis Grease	1

+ Compatible Greases:

- Mobilix #2 found at Mobil Service Stations
- Ronex MP found at Exxon Service Stations
- Super Lube MEP #2 & Super Stay-M #2 found at Conoco Stations
- Shell Alvania #2 found at Shell Service Stations
- Lidok EP #2 found at industrial shops
- Timken Lithium Multi-Use #2 found at industrial shops

* PROCEDURE: Remove grease cap, part number 484195. Remove plug, part number 482028-01, and install grease zerk. Apply grease to the fitting until new grease appears at the top of the caster extension. Remove the grease zerk and reinstall the plug. Reinstall the grease cap. Special tool, part number 47007, is recommended for use in the installation of the grease cap.

GREASE FITTING LUBRICATION

LUBRICANT / INTERVAL

- LITHIUM MP WHITE GREASE 2125
(40 HOURS / WEEKLY)
- CHASSIS GREASE
(100 HOURS / BI-MONTHLY)
- ⬡ CHASSIS GREASE
(200 HOURS / MONTHLY)
- △ CHASSIS GREASE
(500 HOURS / YEARLY)

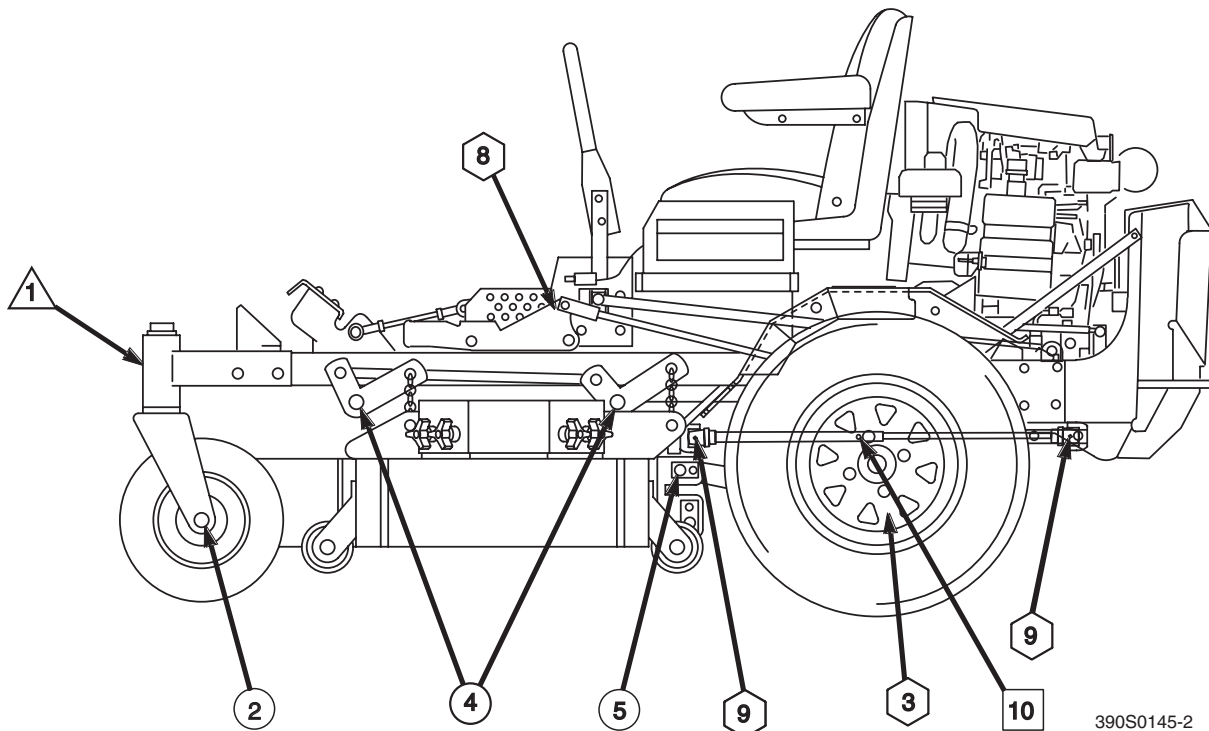
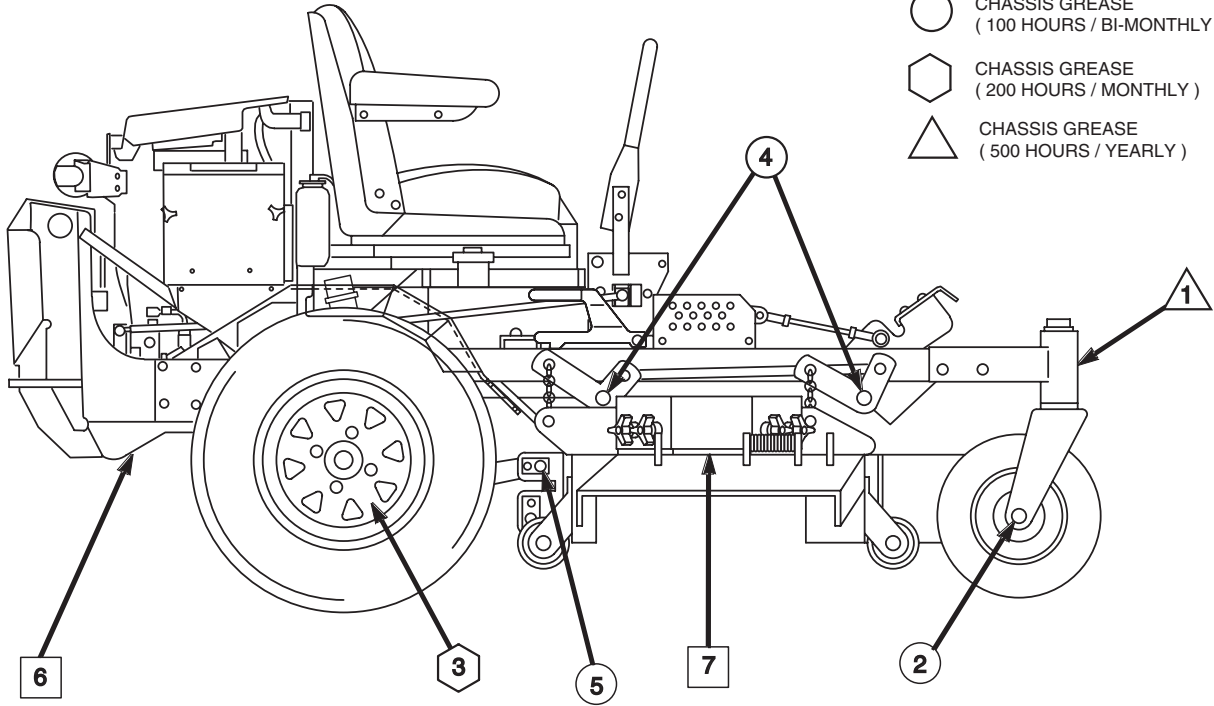

390S0145-2

Figure 7-1. Lubrication Fitting Points

7.3 HYDRAULIC SYSTEM

A. CHECKING HYDRAULIC OIL LEVEL

The hydraulic oil level should be checked after the first 10 hours of operation. Thereafter, check the oil after every 200 hours of machine operation or monthly, whichever occurs first.

- IMPORTANT -

If the oil level is consistently low, check for leaks and correct immediately.

1. Wipe dirt and contaminants from around the reservoir cap. Remove the cap from the hydraulic oil reservoir.
2. Visually check the level of hydraulic oil. Hydraulic oil must be at least 3" inches from top of the filler neck. If the level cannot be determined visually, use a clean tape measure to check the level. If the fluid is low, add 20W50 motor oil. DO NOT overfill; (overfilling the oil reservoir may cause oil seepage around the cap area).
3. Clean the fill cap and install it onto the reservoir.

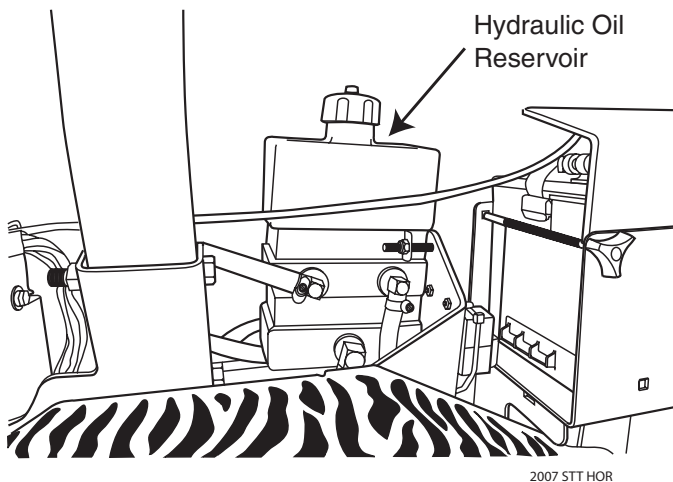

Figure 7-2. Hydraulic Oil Reservoir

B. CHANGING HYDRAULIC OIL

The hydraulic oil should be changed after every 500 hours or annually, whichever occurs first. The oil should also be changed if the color of the fluid has become black or milky. A black color and/or a rancid odor usually indicates possible overheating of the oil, and a milky color usually indicates water in the hydraulic oil.

- IMPORTANT -

The hydraulic oil should be changed if you notice the presence of water or a rancid odor to the hydraulic oil.

1. Park the mower on a level surface and stop the engine.
2. Place a suitable container under the hydraulic oil filter. Remove the fill cap from the reservoir. Remove the hydraulic oil filter. (See Figure 7-3). Allow the fluid to drain into the container and properly discard it.
3. Install a new filter element. See Procedure C.

- NOTE -

Before refilling the hydraulic oil reservoir the hydraulic oil filter should be changed as outlined in Procedure C "Changing Hydraulic Oil Filter Element" on the next page.

4. Fill the reservoir to 3" inches from the top of the filler neck with 20W50 motor oil.
5. Replace the reservoir fill cap. Start the engine and drive forward and backward for two minutes. Check the oil level in the reservoir. If necessary, add oil to the reservoir.

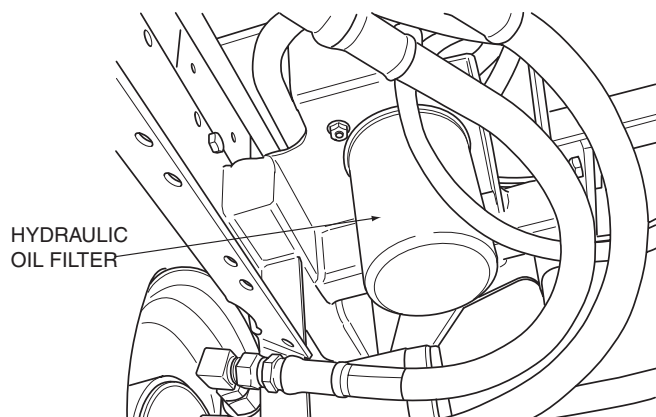

Figure 7-3. Hydraulic Oil Filter

C. CHANGING HYDRAULIC OIL FILTER ELEMENT

The hydraulic oil filter should be changed after every 500 hours of operation or annually, whichever occurs first.

1. Remove the oil filter element (Figure 7-3) and properly discard it. Fill the new filter with clean oil and install the filter. Hand tighten only.

Section 7

- Run the engine at idle speed with the speed control lever in neutral for five minutes.
- Check the oil level in the hydraulic tank. It must be 3" inches from the top of the filler neck. If necessary, add SAE 20W50 motor oil.

7.4 ENGINE OIL

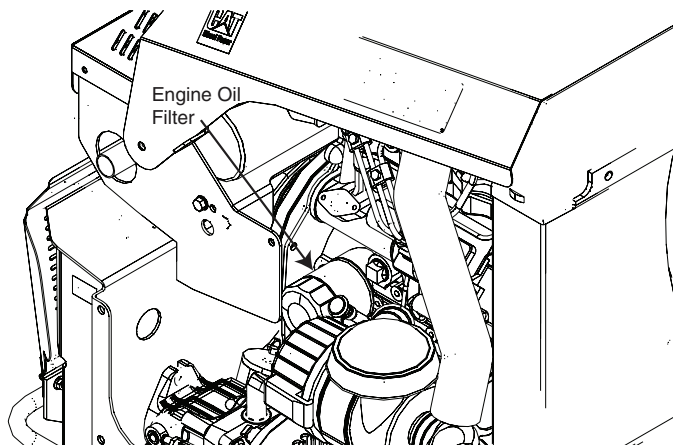

Figure 7-4. Engine Oil Filter

A. CHECKING ENGINE CRANKCASE OIL LEVEL

The engine oil level should be checked after every 8 hours of operation or daily as instructed in the Engine Operator's Manual furnished with this mower.

B. CHANGING ENGINE CRANKCASE OIL

After the first 20 hours of operation, change the engine crankcase oil and replace the oil filter. Thereafter, change the engine crankcase oil after every 100 hours of operation or bi-weekly, whichever occurs first. Refer to the Engine Operator's Manual furnished with this mower for instructions.

C. CHANGING ENGINE OIL FILTER

After the first 20 hours of operation, replace the engine oil filter. Thereafter, replace the oil filter after every 200 hours of operation or every month, whichever occurs first. Refer to Engine Operator's Manual for instructions (See Figure 7-4).

7.5 ENGINE FUEL SYSTEM

DANGER

To avoid injury from burns, allow the mower to cool before removing the fuel tank cap and refueling.

A. FILLING THE FUEL TANK

Fill the fuel tank at the beginning of each operating day to within one inch below the filler neck. Do not overfill. Use clean, fresh diesel fuel with a minimum cetane rating of 40.

B. REPLACING FUEL FILTER ELEMENT

The in-line fuel pre-filter and engine fuel filter should be replaced after every 500 hours of operation or annually, whichever occurs first. See Figure 7-5.

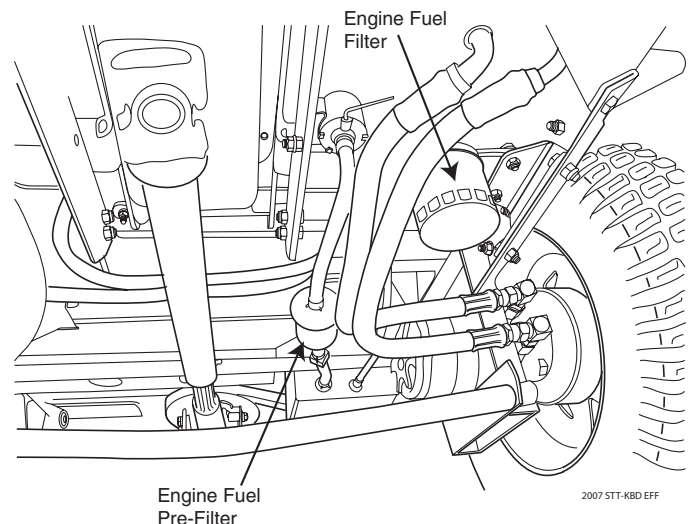

Figure 7-5. Fuel Filter

- Close the shut-off valve. Remove the two clamps securing the inline fuel pre-filter to the fuel hose. Remove the fuel pre-filter.
- Install a new fuel pre-filter. Be sure it is installed in the proper direction. Secure to the fuel hose using the two clamps.
- Remove and replace the engine fuel filter. Open the fuel shut-off valve.

7.6 ENGINE AIR CLEANER

A. CLEANING AND/OR REPLACING AIR CLEANER ELEMENT

For any air cleaner, the operating environment dictates the air cleaner service periods. To make it convenient for you we have installed an "Air Cleaner Indicator" which is located just behind the air filter. The indicator window will turn red when it is time to service the air filter. Do not service the filter unless this indicator is red.

- NOTE -

In extremely dusty conditions it may be necessary to check the indicator daily to prevent engine damage.

1. Snap open the two clips securing the air cleaner cover to the air cleaner box. Remove the air cleaner cover, clean the duck bill vent of any dust and set the cover aside.
2. Remove the air cleaner element and inspect.
3. Clean or replace the element as recommended by the engine manufacturer.
4. Replace the air filter cover and be sure to snap the two clips closed.
5. Reset the air cleaner indicator by pushing the button on the end of the indicator. The indicator window should return to clear.

7.7 BATTERY

WARNING

Lead-acid batteries produce flammable and explosive gases. To avoid personal injury when checking, testing or charging batteries, DO NOT use smoking materials near batteries. Keep arcs, sparks and flames away from batteries. Provide proper ventilation and wear safety glasses.

WARNING

Battery posts, terminals, and related accessories contain lead and lead compounds, chemicals known to cause cancer and reproductive harm. Wash hands after handling.

WARNING

Electric storage battery fluid contains sulfuric acid which is POISON and can cause SEVERE CHEMICAL BURNS. Avoid contact of fluid with eyes, skin, or clothing. Use proper protective gear when handling batteries. DO NOT tip any battery beyond 45° angle in any direction. If fluid contact does occur, follow first aid suggestions below.

BATTERY ELECTROLYTE FIRST AID

External Contact — Flush with water.

Eyes — Flush with water for at least 15 minutes and get medical attention immediately.

Internal — Drink large quantities of water. Follow with Milk Of Magnesia, beaten egg, or vegetable oil. Get medical attention immediately. In case of internal contact, DO NOT give fluids that would induce vomiting.

B. CHARGING THE BATTERY

Refer to the battery charger's manual for specific instructions.

Under normal conditions the engine's alternator will have no problem keeping a charge on the battery. If the battery has been completely discharged for a long period of time, the alternator may not be able to recharge the battery, and a battery charger will be required.

DO NOT charge a frozen battery. It may explode and cause injury. Let the battery warm before attaching a charger.

Section 7

Whenever possible, remove the battery from the mower before charging and make sure the electrolyte covers the plates in all cells.



WARNING

BATTERIES PRODUCE EXPLOSIVE GASES. Charge the battery in a well ventilated space so gases produced while charging can dissipate.

Charging rates between 3 and 50 amperes are satisfactory if excessive gassing or spewing of electrolyte does not occur or the battery does not feel excessively hot (over 125°F). If spewing or gassing occurs or the temperature exceeds 125°F, the charging rate must be reduced or temporarily stopped to permit cooling.

C. JUMP STARTING

1. The booster battery must be a 12 volt type. If a vehicle is used for jump starting, it must have a negative ground system.
2. When connecting the jumper cables, connect the positive cable to the positive battery post, then connect the negative cable to the negative battery post.

7.8 DRIVE BELTS

All drive belts are spring loaded and self-tensioning, however after the first 2, 4, 8 and 10 hours of operation, the belts should be checked for proper alignment and wear. Thereafter, check the belts after every 40 hours of operation or weekly, whichever occurs first.

- NOTE -

If you experience frequent belt wear or breakage, see your authorized Scag service center for belt adjustment.



WARNING

If the pump drive belt fails, steering control will be lost which could result in serious injury or death. Replace the pump drive belt as needed or every 400 hours / 2 years, whichever occurs first.

7.9 CUTTER BLADES

A. BLADE INSPECTION

1. Remove the ignition key before servicing the blades.
2. Raise the mower deck to the highest position. Place the lanyard pin in the highest cutting height position to prevent the cutter deck from falling.



WARNING

Always wear proper hand and eye protection when working with cutter blades.

3. Check the cutter blades for straightness. If the cutter blades appear bent, they will need to be replaced.



WARNING

Do not attempt to straighten a bent blade, and never weld a broken or cracked blade. Always replace it with a new blade to assure safety.

4. If a blade cutting edge is dull or nicked, it should be sharpened. Remove the blades for sharpening. See "Blade Replacement."

- NOTE -

Keep the blades sharp. Cutting with dull blades not only yields a poor mowing job, but slows the cutting speed of the mower and causes extra wear on the engine and the blade drive by pulling hard.

B. BLADE SHARPENING

- NOTE -

If possible, use a file to sharpen the blade. Using a wheel grinder may burn the blade.

- NOTE -

DO NOT sharpen the blades beyond 1/3 of the width of the blade. See Figure 7-6.

1. Sharpen the cutting edge at the same bevel as the original. See Figure 7-6. Sharpen only the top of the cutting edge to maintain sharpness.

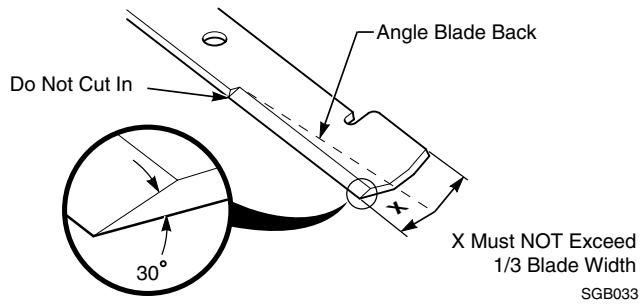

Figure 7-6. Blade Sharpening

2. Check the balance of the blade. If the blades are out of balance, vibration and premature wear can occur. See your authorized Scag dealer for blade balancing or special tools, if you choose to balance your own blades.

C. BLADE REPLACEMENT



WARNING

Always wear proper hand and eye protection when working with cutter blades.

1. Remove the ignition key before replacing the blades.
2. Raise the mower deck to the highest position. Place the lanyard pin in the highest cutting height position to prevent the cutter deck from falling.
3. Secure the cutter blades to prevent them from rotating, (use the optional Blade Buddy tool P/N 9212, to assist in securing the cutter blades), remove the nut from the blade attaching bolt. Remove the cutter blade, bolt and spacer from the spindle shaft. (Figure 7-7)

- NOTE -

The front of the machine will have to be raised slightly to remove the blade bolt from the cutter spindle.

4. To install the new cutter blade, put the flat washer onto the blade bolt and slide the bolt into the hole in the cutter blade.

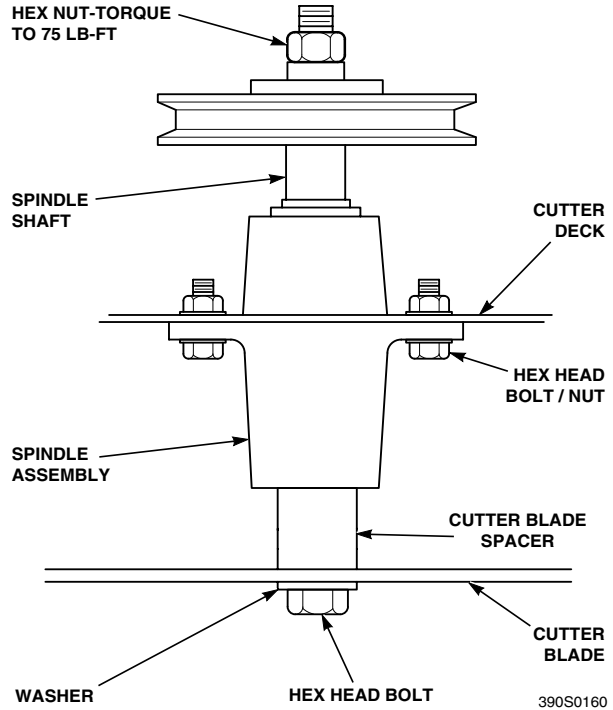

Figure 7-7. Blade Replacement

- NOTE -

Be sure that the blade is installed with the lift wing toward the top.

5. Install the spacer onto the blade bolt and insert the bolt into the cutter spindle shaft.
6. Install the hex nut to the blade bolt at the top of the cutter spindle. Secure the blades from rotating and torque to 75 ft/lbs. (See Figure 7-7)

7.10 TIRES

Check the tire pressures after every 8 hours of operation or daily.

Caster Wheels
Drive Wheels

Flat Free
12 PSI

Section 7

7.11 CUTTER DECK GEARBOX

A. CHECKING LUBRICANT LEVEL

⚠ CAUTION

The cutter deck gearbox can reach high operating temperatures. Allow the cutter deck gearbox to cool before servicing.

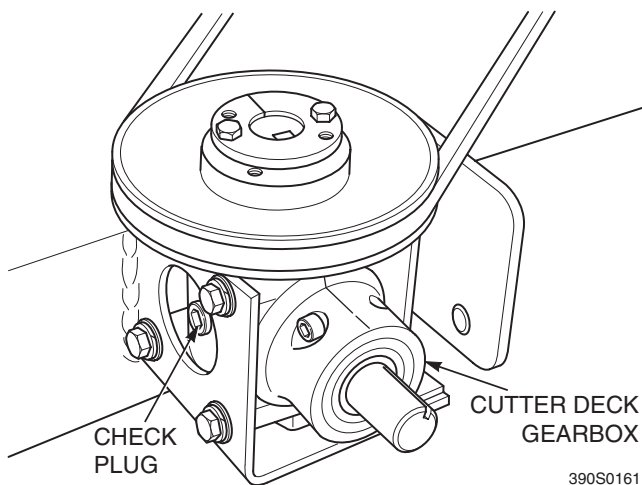

Figure 7-8. Cutter Deck Gearbox

The fluid level in the cutter deck gearbox (Figure 7-8) should be checked after every 100 hours of operation or bi-weekly, whichever occurs first.

1. Lower the cutter deck to its lowest position to gain access to the cutter deck gearbox.
2. Clean and remove the check plug from the side of the gearbox (See Figure 7-8). Visually check that the lubricant level is up to the bottom edge of the check plug hole. If lubricant is low, add SAE 80/90 lubricant through the check plug hole in the gearbox until it is level with the bottom of the check plug hole. Install the check plug and tighten securely.

B. CHANGING LUBRICANT

The lubricant in the cutter deck gearbox should be changed every 500 hours of operation or yearly, whichever occurs first.

1. Place a suitable container beneath the cutter deck gearbox and locate the gearbox drain plug.
2. Remove the drain plug and drain the lubricant into the container and properly discard it.
3. Re-install the drain plug and add EP-80/90 lubricant through the check plug hole in the gearbox until it is level with the bottom of the check plug hole. Install the check plug and tighten securely.

7.12 COOLING SYSTEM

⚠ WARNING

To avoid burns, always allow the engine to cool before removing the radiator cap.

A. CHECKING COOLANT LEVEL

The coolant level should be checked before each day of operation.

1. Remove the radiator cap by turning it slowly counterclockwise to the first stop and allow any pressure to be released. Push down on the cap and turn counterclockwise to remove.
2. Visually check the coolant level. The coolant level should be up to the bottom of the filler neck as shown in Figure 7-9. Add a mixture of coolant and soft water as needed.

- NOTE -

Refer to the coolant manufacturer's instructions for the proper coolant mixture ratio.

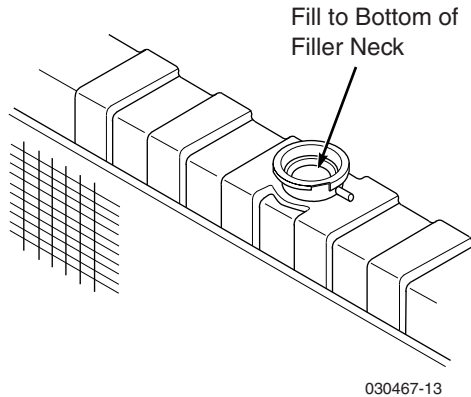

Figure 7-9. Coolant Level in Radiator

3. Replace the radiator cap. Push down on the cap and turn clockwise until it stops.

- NOTE -

The cooling system should be flushed and the coolant replaced every 500 hours of operation or annually. See your Scag dealer for proper coolant replacement.

B. CLEANING THE RADIATOR DEBRIS SCREEN

After each day of operation, remove and clean the radiator debris screen.

CAUTION

To avoid personal injury, always wear safety glasses when using compressed air.

1. Release latches and pull the debris screen up to remove.
2. Clean the debris screen with compressed air or a water hose.

- NOTE -

Check the radiator for excessive debris and clean with compressed air. Never spray a hot engine with water, use only compressed air to remove debris.

3. Re-install the debris screen to the radiator.

C. CHECKING THE FAN BELT TENSION

Periodically check the fan belt tension. The belt should deflect 1/2" with 10 pounds of pressure. See your Scag dealer if the belt is in need of adjustment or replacement.

7.13 BODY, DECK, AND UPHOLSTERY

CAUTION

Do not wash any portion of the equipment while it is hot. Do not wash the engine; use compressed air.

1. After each use, wash the mower and cutter deck. Use cold water and automotive cleaners. Do not use pressure cleaners.
2. Do not spray electrical components.
3. Use a mild soap solution or a vinyl/rubber cleaner to clean the seat.
4. Repair damaged metal surfaces using Scag touch-up paint available from your authorized Scag dealer. Wax the mower for maximum paint protection.

