

**MARUTI**  **SUZUKI**

Presents

**SUPRA SAEINDIA**



***Student Formula***

**Buddh International Circuit,  
Greater Noida**



**STUDENT FORMULA  
RULE BOOK 2019**

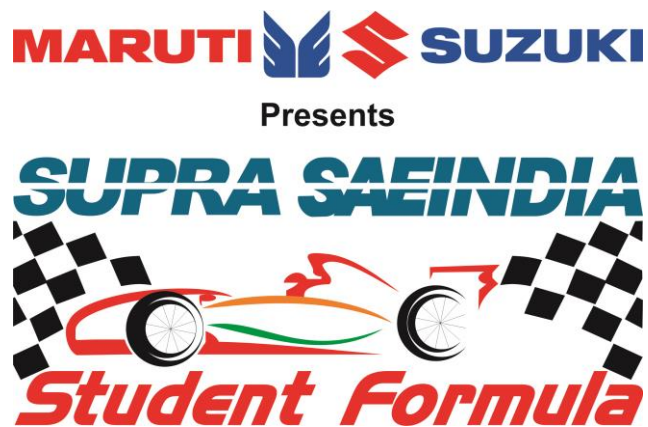

# **STUDENT FORMULA**

## **Rule Book 2019**

## CONTENTS

CHAPTER	TITLE	PAGE NO
	INTRODUCTION	1
<b>PART A</b>	<b>ADMINISTRATIVE REGULATIONS</b>	<b>2</b>
	ARTICLE 1: STUDENT FORMULA OVERVIEW AND COMPETITION	2
	ARTICLE 2: THE 2018 STUDENT FORMULA SERIES	3
	ARTICLE 3: STUDENT FORMULA RULES AND ORGANIZER AUTHORITY	4
	ARTICLE 4: INDIVIDUAL PARTICIPATION REQUIREMENTS	5
	ARTICLE 5: FACULTY ADVISOR, SAFETY RESPONSIBLE AND SAFETY ADVISOR	6
	ARTICLE 6: VEHICLE ELIGIBILITY	7
	ARTICLE 7: REGISTRATION	8
	ARTICLE 8: VEHICLE DOCUMENTATION, DEADLINES AND PENALTIES	9
	ARTICLE 9: PROTESTS	11
	ARTICLE 10: QUESTIONS ABOUT THE STUDENT FORMULA RULES	12
	APPENDIX S - SAE TECHNICAL STANDARDS	13
<b>PART T</b>	<b>GENERAL TECHNICAL REQUIREMENTS</b>	<b>14</b>
	ARTICLE 1: VEHICLE REQUIREMENTS & RESTRICTIONS	14
	ARTICLE 2: GENERAL DESIGN REQUIREMENTS	15
	ARTICLE 3: DRIVER'S CELL	16
	ARTICLE 4: COCKPIT	33
	ARTICLE 5: DRIVERS EQUIPMENT (BELTS AND COCKPIT PADDING)	36
	ARTICLE 6: GENERAL CHASSIS RULES	42
	ARTICLE 7: BRAKE SYSTEM	45
	ARTICLE 8: POWERTRAIN	46
	ARTICLE 9: AERODYNAMIC DEVICES	48
	ARTICLE 10: COMPRESSED GAS SYSTEMS AND HIGHPRESSURE HYDRAULICS	49
	ARTICLE 11: FASTENERS	50
	ARTICLE 12: TRANSPONDERS	50
	ARTICLE 13: VEHICLE IDENTIFICATION	51
	ARTICLE 14: EQUIPMENT REQUIREMENTS	53
	ARTICLE 15: POSSIBLE FUTURE RULES CHANGES	57
	<b>APPENDIX T-1 STRUCTURAL EQUIVALENCY SPREADSHEET</b>	<b>59</b>
	<b>APPENDIX T-2 IMPACT ATTENUATOR DATA REPORT</b>	<b>59</b>

CHAPTER	TITLE	PAGE NO
<b>PART IC</b>	<b>INTERNAL COMBUSTION ENGINE VEHICLES</b>	<b>60</b>
	ARTICLE 1: INTERNAL COMBUSTION ENGINE POWERTRAINS	60
	ARTICLE 2: FUEL AND FUEL SYSTEM	63
	ARTICLE 3: EXHAUST SYSTEM AND NOISE CONTROL	66
	ARTICLE 4: ELECTRICAL SYSTEM	67
<b>PART S</b>	<b>STATIC EVENT REGULATIONS</b>	<b>70</b>
	ARTICLE 1: STATIC EVENTS AND MAXIMUM SCORES	70
	ARTICLE 2: TECHNICAL INSPECTION	70
	ARTICLE 3: BUSINESS LOGIC PLAN	72
	ARTICLE 4: COST AND MANUFACTURING EVENT	73
	ARTICLE 5: PRESENTATION EVENT	87
	ARTICLE 6: DESIGN EVENT	88
	<b>APPENDIX S - 1 COST MODEL AND COST METHODOLOGY</b>	93
	<b>APPENDIX S - 2 STANDARD PART NUMBERING</b>	99
	<b>APPENDIX S - 3 ORGANIZED LIST OF SYSTEMS &amp; ASSEMBLIES</b>	100
	<b>APPENDIX S - 4 POWER TOOL PACKAGE ENVELOPES</b>	101
	<b>APPENDIX S - 5 2018 SUPRA SAEINDIA COST EVENT ADDENDUM</b>	102
	<b>APPENDIX S - 6 PRESENTATION JUDGING</b>	103
	<b>APPENDIX S - 7 DESIGN JUDGING</b>	104
<b>PART D</b>	<b>DYNAMIC EVENT REGULATIONS</b>	<b>105</b>
	ARTICLE 1: DYNAMIC EVENTS AND MAXIMUM SCORES	105
	ARTICLE 2: WEATHER CONDITIONS	105
	ARTICLE 3: RUNNING IN RAIN	105
	ARTICLE 4: DRIVER LIMITATIONS	108
	ARTICLE 5: ACCELERATION EVENT	108
	ARTICLE 6: SKID-PAD EVENT	109
	ARTICLE 7: AUTOCROSS EVENT	112
	ARTICLE 8: ENDURANCE AND Engineering Excellence	114
	ARTICLE 9: FLAGS	123
	ARTICLE 10: RULES OF CONDUCT	125
	ARTICLE 11: GENERAL RULES	126
	ARTICLE 12: PIT RULES	127
	ARTICLE 13: DRIVING RULES	129
	ARTICLE 14: DEFINITIONS	129

## 2018 STUDENT FORMULA RULES

### INTRODUCTION

This introduction highlights some areas of the 2018 STUDENT FORMULA rules that teams should understand and consider. This introduction only summarizes parts of the rules the revised text and do not change or replace the rules.

**Caution** - Neither this introduction, nor any other summary, is a substitute for reading and understanding the Rules. The Rules are both a controlling and a reference document and should be used for those purposes. Do not attempt to design your car based on the parts of the Rules you happen to remember from the last time you read them. We cannot stress it too strongly - Read the Rules thoroughly and repeatedly.

**Revised Part Designations** - The designations of some of the Parts of the STUDENT FORMULA Rules have been revised to better indicate their contents. The new designations are:

Part	A	Administrative Regulations
Part	T	General Technical Requirements
Part	IC	Internal Combustion Engine Vehicles
Part	S	Static Event Regulations
Part	D	Dynamic Event Regulations

**T3.10.4 on the location of the 95<sup>th</sup> percentile template** - The location of the template in relation to the face of the pedals has been specified.

**T5.6 Head Restraint** - The head restraint regulations have been revised and clarified.

**Part IC - Internal Combustion Vehicles** - To simplify the rules we have separated the rules governing internal combustion vehicles from the general technical requirements.

**S3.1 Business Logic Case** - Each team is required to submit a brief "business logic case" which states the primary considerations and goals that influenced their design and fabrication choices. This submission replaces the Student Activity Disclosure Form.

**C5.7 - Student Activity Disclosure Form**" and all associated cross references including those in A8.1 "Required Documents and Required Forms" and A8.4 "Late Submission Penalties" - **The requirement to submit the "Student Activity Disclosure Form" is eliminated.**

---

## 2018 STUDENT FORMULA RULES

### PART A - ADMINISTRATIVE REGULATIONS

#### ARTICLE 1: STUDENT FORMULA OVERVIEW AND COMPETITION

##### A1.1 STUDENT FORMULA Competition Objective

The STUDENT FORMULA competitions challenge teams of university undergraduate and graduate students to conceive, design, fabricate, develop and compete with small, formula style, vehicles.

A1.1.1 To give teams the maximum design flexibility and the freedom to express their creativity and imaginations there are very few restrictions on the overall vehicle design. The challenge to teams is to develop a vehicle that can successfully compete in all the events described in the STUDENT FORMULA Rules. The competitions themselves give teams the chance to demonstrate and prove both their creativity and their engineering skills in comparison to teams from other universities around the world.

##### A1.2 Vehicle Design Objectives

For the purpose of the STUDENT FORMULA competition, teams are to assume that they work for a design firm that is designing, fabricating, testing and demonstrating a prototype vehicle for the non-professional, weekend, competition market.

A1.2.1 The vehicle should have very high performance in terms of acceleration, braking and handling and be sufficiently durable to successfully complete all the events described in the STUDENT FORMULA Rules and held at the STUDENT FORMULA competitions.

A1.2.2 The vehicle must accommodate drivers whose stature ranges from 5<sup>th</sup> percentile female to 95<sup>th</sup> percentile male and must satisfy the requirements of the STUDENT FORMULA Rules.

A1.2.3 Additional design factors to be considered include: aesthetics, cost, ergonomics, maintainability, manufacturability, and reliability.

A1.2.4 Once the vehicle has been completed and tested, your design firm will attempt to "sell" the design to a "corporation" that is considering the production of a competition vehicle. The challenge to the design team is to develop a prototype car that best meets the STUDENT FORMULA vehicle design goals and which can be profitably marketed.

A1.2.5 Each design will be judged and evaluated against other competing designs to determine the best overall car.

##### A1.3 Good Engineering Practices

Vehicles entered into STUDENT FORMULA competitions are expected to be designed and fabricated in accordance with good engineering practices.

#### A1.4 Judging Categories

The cars are judged in a series of static and dynamic events including: technical inspection, cost, **presentation** **Marketing Presentation**, and engineering design, solo performance trials, and high performance track endurance.

A1.4.1 The dynamic events are scored to determine how well the car performs. Each dynamic event has specified minimum acceptable performance levels that are reflected in the scoring equations.

The following points are possible:

##### Static Events:

Marketing Presentation	75
Engineering Design	150
Cost Analysis	100

##### Dynamic Events

Acceleration	75
Skid-Pad	50
Autocross	150
Engineering Excellence	100
Endurance	300

**Total Points 1000**

## ARTICLE 2: THE 2018 STUDENT FORMULA SERIES

### A2.2 Open Registration

STUDENT FORMULA competitions have open registration policies and accept registrations by student teams representing universities Which Have a SAEINDIA Collegiate Club in the country.

### A2.3 Rule Variations

All competitions in the STUDENT FORMULA Series may post some minor rule variations specific to the operation of the events in the country. However, the vehicle design requirements and restrictions will remain unchanged. Any rule variations will be posted on the website specific to The competition.

### A2.4 Official Announcements and Competition Information

Teams are required to read the published announcements by SAEINDIA and the other organizing bodies and to be familiar with all official announcements concerning the competitions and rules interpretations released by the STUDENT FORMULA Rules Committee.

A2.4.1 STUDENT FORMULA news is published online and can be found at: [www.suprasaeindia.org](http://www.suprasaeindia.org)

## **A2.5 Official Languages**

The official language of the STUDENT FORMULA series is English. Document submissions, presentations and discussions in English are acceptable at all competitions in the series.

## **ARTICLE 3: STUDENT FORMULA RULES AND ORGANIZER AUTHORITY**

### **A3.1 Rules Authority**

The STUDENT FORMULA Rules are the responsibility of the STUDENT FORMULA Rules Committee and are issued under the authority of the SAEINDIA Collegiate Design Series.

A3.1.1 Official announcements from the STUDENT FORMULA Rules Committee, SAEINDIA or the other SUPRA SAEINDIA organizing bodies shall be considered part of, and shall have the same validity as, these rules.

A3.1.2 Ambiguities or questions concerning the meaning or intent of these rules will be resolved by the STUDENT FORMULA Rules Committee, SAEINDIA.

### **A3.2 Rules Validity**

The STUDENT FORMULA Rules posted on the SUPRASAEINDIA website and dated for the calendar year of the competition are the rules in effect for the competition.

**The Part and Articles Missing from the FSAE Rules are not applicable for SUPRA SAEINDIA STUDENT FORMULA event hence it has been deleted.**

A3.2.1 Rule sets dated for other years are invalid.

### **A3.3 Rules Compliance**

By entering a STUDENT FORMULA competition the team, members of the team as individuals, faculty advisors and other personnel of the entering university agree to comply with, and be bound by, these rules and all rule interpretations or procedures issued or announced by SAEINDIA, the STUDENT FORMULA Rules Committee and the other organizing bodies.

A3.3.1 Any rules or regulations pertaining to the use of the competition site by teams or individuals and which are posted, announced and/or otherwise publically available are incorporated into the STUDENT FORMULA Rules by reference. As examples, all event site waiver requirements, speed limits, parking and facility use rules apply to SUPRA SAEINDIA participants.

A3.3.2 All team members, faculty advisors and other university representatives are required to cooperate with, and follow all instructions from, competition organizers, officials and judges.

### **A3.4 Understanding the Rules**

Teams, team members as individuals and faculty advisors, are responsible for reading and understanding the rules in effect for the competition in which they are participating.



### **A3.5 Participating in the Competition**

Teams, team members as individuals, faculty advisors and other representatives of a registered university who are present on-site at a competition are considered to be "participating in the competition" from the time they arrive at the event site until they depart the site at the conclusion of the competition or earlier by withdrawing.

### **A3.6 Violations on Intent**

The violation of intent of a rule will be considered a violation of the rule itself.

A3.6.1 Questions about the intent or meaning of a rule may be addressed to the STUDENT FORMULA Rules Committee.

### **A3.7 Right to Impound**

SAEINDIA and other competition organizing bodies reserve the right to impound any onsite registered vehicles at any time during a competition for inspection and examination by the organizers, officials and technical inspectors.

### **A3.8 Restriction on Vehicle Use**

Teams are cautioned that the vehicles designed in compliance with these STUDENT FORMULA Rules are intended for competition operation only at the official STUDENT FORMULA competitions.

### **A3.9 Headings**

The article, section and paragraph headings in these rules are provided only to facilitate reading: they do not affect the paragraph contents.

### **A3.10 General Authority**

SAEINDIA and the competition organizing bodies reserve the right to revise the schedule of any competition and/or interpret or modify the competition rules at any time and in any manner that is, in their sole judgment, required for the efficient operation of the event or the STUDENT FORMULA series as a whole.

A list of SAE Technical Standards can be found in Appendix S.

## **ARTICLE 4: INDIVIDUAL PARTICIPATION REQUIREMENTS**

### **A4.1 Eligibility Limits**

Eligibility is limited to undergraduate and graduate students to insure that this is an engineering design competition.

### **A4.2 Student Status**

Team members must be enrolled as degree seeking undergraduate or graduate students in the college or university of the team with which they are participating. Team members who have graduated during the seven (7) month period prior to the competition remain

eligible to participate. (Example: Final Year Students of **2016** cannot participate in the 2018 event. But final year student of 2018 can participate.)

#### **A4.3 Society Membership**

Team members must be members (**+1 Membership**) of at least one of the following societies (If Not, Member will not be allowed to participate): (1) SAEINDIA, (2) SAE International, (3) SAE Australasia, (4) SAE Brazil, (5) JSAE, (6) TSAE. Proof of membership, such as membership card, is required at the competition.

**Note:** Students can join SAEINDIA online at: [www.saeindia.org](http://www.saeindia.org).

#### **A4.4 Age**

Team members must be at least eighteen (18) years of age.

#### **A4.5 Driver's License**

Team members who will drive a competition vehicle at any time during a competition must hold a valid, government issued driver's license.

#### **A4.6 Liability Waiver**

All on-site participants, including students, faculty and volunteers, are required to sign a liability waiver upon registering on-site.

#### **A4.7 Medical Insurance**

Individual medical insurance coverage is required and is the sole responsibility of the participant. Participants without a valid Medical Insurance will not be allowed to participate in the Dynamic Events.

#### **A4.9 Onsite Registration Requirement**

ONSITE REGISTRATON IS REQUIRED OF ALL TEAM MEMBERS AND FACULTY ADVISORS. Bring your (1) Government issued driver's license or passport and (2) your medical insurance card (Mandatory for Drivers) (3) College ID (4) SAEINDIA Membership Card, Approval Letter from College in college letter Head and documentation to onsite registration.

### **ARTICLE 5: FACULTY ADVISOR**

#### **A5.1 Faculty Advisor**

A5.1.1 Each team is expected to have a Faculty Advisor appointed by the university. It is **Mandatory for the Faculty Advisor to accompany the team** to the competition and will be considered by competition officials to be the official university representative. Failure to abide by this rule may deny participation of the team in Dynamic Events.

A5.1.2 Faculty Advisors may advise their teams on general engineering and engineering project management theory.

A5.1.3 Faculty Advisors may not design any part of the vehicle nor directly participate in the development of any documentation or presentation.

Additionally, Faculty Advisors may not fabricate nor assemble any components nor assist in the preparation, maintenance, testing or operation of the vehicle.

In Brief - Faculty Advisors may not design, build or repair any part of the car.

## **ARTICLE 6: VEHICLE ELIGIBILITY**

### **A6.1 Student Developed Vehicle**

Vehicles entered into STUDENT FORMULA competitions must be conceived, designed, fabricated and maintained by the student team members without direct involvement from professional engineers, automotive engineers, racers, machinists or related professionals.

### **A6.2 Information Sources**

The student team may use any literature or knowledge related to car design and information from professionals or from academics as long as the information is given as a discussion of alternatives with their pros and cons.

### **A6.3 Professional Assistance**

Professionals may not make design decisions or drawings and the Faculty Advisor may be required to sign a statement of compliance with this restriction.

### **A6.4 Student Fabrication**

It is the intent of the SAEINDIA Collegiate Design Series competition is to provide direct hands-on experience to the students. Therefore, students should perform all fabrication tasks whenever possible.

The Fabrication should be done on-campus using in-house facilities of college / university. All works done outside the Campus need to be informed to the SUPRA SAEINDIA Rules Committee and prior approval acquired for the same.

### **A6.5 the STUDENT FORMULA Competition Year - First Year Cars**

For the purpose of defining first, second and third year cars, a competition "year" is any consecutive run of the Series, i.e. For example, a car that competes first time in STUDENT FORMULA 2018 is classified as a "first year car" until the following year's STUDENT FORMULA 2018 roughly 12 month period counting from the event in which a vehicle first competes in a competition.

**Note:** Teams are reminded that their vehicles must comply with the rules in effect for each competition they enter.

### **A6.6 First year Vehicles - STUDENT FORMULA 2018 Competition Year**

A6.6.1 Only First Year Vehicles may enter the STUDENT FORMULA 2018 EVENT.

## ARTICLE 7: REGISTRATION

### A7.1 Registration - STUDENT FORMULA Competitions

Registration for STUDENT FORMULA competitions held in 2018 must be completed on-line. Online registration must be done by either (a) an SAEINDIA member or (b) the official faculty advisor connected with the registering university and recorded as such in the SAEINDIA record system. **Team Once Registered, No Changes will be allowed in the Team list (Members) including Faculty Advisor**

**Note:** It typically takes at least 10 working Days between the time you complete an on-line SAEINDIA membership application and our system recognizes you as eligible to register your team.

### A7.2 Entries per University - STUDENT FORMULA 2018 Competitions - Registering Teams –

For the purposes of registering and competing, a Universities team are considered to be separate and independent entities if they are from a different campus. A university may register as many teams in the same competition; however only one team per university campus will be selected for the final event based on their performance and university recommendation.

### A7.3 Registration Limits - STUDENT FORMULA Competitions

Registration limits for the STUDENT FORMULA 2018 competitions will be posted on the SUPRA SAEINDIA website.

Registration for each SUPRA SAEINDIA competitions closes as soon as the registration limit is reached. We strongly advise teams to register as soon as registration opens. (First come First Serve Basis)

### A7.4 Registration Dates - STUDENT FORMULA Competitions

Registration for the STUDENT FORMULA competitions will close at the date and time posted on the competition website or when all the registration slots have been taken, whichever occurs first.

There are no exceptions to this registration policy.

### A7.6 Registration Fees

A7.6.1 Registration fees must be paid to the organizer by the deadlines specified on the respective competition website.

A7.6.2 Registration fees are **not refundable** and **will not be transferred** to a subsequent year's competition.

### A7.7 Withdrawals

A7.7.1 Registered teams that find that they will not be able to attend the competition are requested to officially withdraw by notifying the following **no later than one (2) Months** before the event:

A7.7.2 STUDENT FORMULA Event withdrawals: Mr. Bibhu Kumar, [suprasaeindia@saeindia.org](mailto:suprasaeindia@saeindia.org).

### **A7.10 On-site Registration**

All team members and faculty advisors must complete the on-site registration procedures immediately after they arrive at the competition site.

On-site registration must be completed and the credentials and/or other identification issued by the organizers properly worn before the car can be unloaded uncrated or worked upon in any manner.

## **ARTICLE 8: VEHICLE DOCUMENTATION, DEADLINES AND PENALTIES**

### **A8.1 Required Documents and Required Forms**

The following documents supporting each vehicle must be submitted by the action deadlines posted on each competition website or otherwise published by the organizers.

T3.9 "Structural Equivalency Spreadsheet (SES)" and Appendix B-1 - - Use the required format and fill accordingly for report preparation which is located at [www.suprasaeindia.org](http://www.suprasaeindia.org)

Note: SES is not required for the teams using a steel tube frame chassis.

T3.22 "Impact Attenuator Data Requirement" - Use required format for IAD report preparation which is located at [www.suprasaeindia.org](http://www.suprasaeindia.org)

S3 "Business Logic Plan" - Use required form located at [www.suprasaeindia.org](http://www.suprasaeindia.org).

S4 "Cost Report" - Report must comply with the Cost Event Rules. Both an electronic version and a hard copy version are required.

S6.2 "Design Report" - Report must comply with the Design Event Rules

S6.3 "Design Spec Sheet" - Use required form located at [www.suprasaeindia.org](http://www.suprasaeindia.org). Program Submissions - Material required for programs is specific to each competition. Check the website(s) of the competition(s) your team has entered for requirements.

### **A8.2 Deadlines**

Volunteer judges evaluate all the required submissions and it is essential that they have enough time to complete their work. There are no exceptions to the document submission deadlines and late submissions will incur penalties. Please note that different documents or submissions may have different deadlines and different late submission penalties - check the event website.

### A8.3 Submission Addresses and Formats

The procedures for submitting documents and the website and/or addresses to which the various documents should be sent are published on the individual event websites or otherwise released by the organizers. Most required documents must be submitted in a format specified in the individual event rules or using a prescribed form. Failure to submit a document in the proper format, or with an incorrect file name, will be considered as "Not Submitted."

Carefully read the event rules and check the website of the competition you are entering.

Notice - Teams will **not** be notified if a document is submitted incorrectly. Each team is responsible for confirming that its documents have been properly uploaded and that the deadlines have been met. Email confirmations to teams are **not** sent

### A8.4 Late Submission Penalties

Documents received /uploaded after the deadline will be penalized with the following penalty caps and exclusions:

T3.9.5 "Structural Equivalency Spreadsheet (SES)" - The penalty for late SES submission is capped at negative Ten (-5) points per day for maximum upto 50 marks. After 10 days teams may be disqualified for appearing in technical inspection during main event.

However, teams are advised that SES forms are evaluated in the order in which they are received and that late submissions will be reviewed last. Late SES approval could delay the completion of your vehicle. We strongly recommend you submit your SES as early as possible.

T3.22.7 "Impact Attenuator Report Penalties" - For Non submission of impact attenuator report -5 marks penalty per day maximum upto 50 marks, After 10 days teams may not be allowed for technical inspection during main event.

Rules S3 "Business presentation" –Delayed submission will add a penalty of -5 marks per day for maximum upto 25 marks. In case team does not submit event after 5 days the Team will not be allowed for business presentation evaluation during main event.

2. Rule S4.16 "Late Submission of Cost Report" - Delayed submission will add a penalty of -5 marks per day for maximum upto 40 marks penalty. (Report Submission Date will be announced later). In case team does not submit even after 8 days the Team will not be allowed for Cost Presentation during main event.

Rule S6.8 "Penalty for Late Submission or Non-submission" - The Design Report and Design Spec Sheet collectively constitute the "Design Documents". – Delayed submission will add a penalty of 10 marks per day for maximum upto 70 marks penalty (Report Submission Date will be announced later). In case team does not submit even after 7 days the Team will not be allowed for Design presentation evaluation during main event.

Rule S6.8 "Penalty for Late Submission or Non-submission" - The Design Report and Design Spec Sheet collectively constitute the "Design Documents". – Delayed submission will add a penalty of 10 marks per day for maximum upto 70 marks penalty (Report Submission Date will be announced later). In case team does not submit even after 7 days the Team will not be allowed for Design presentation evaluation during main event.

Program Submissions - Program submission requirements differ across competitions and may or may not involve penalties. Please submit program material by the published deadlines. This rule is only a summary; it does not supersede the individual event rules. Read the individual rules for complete document submission requirements. Check the competition websites for deadlines, submission addresses and other details. If you have any questions - ask us.

Note: The format for each report with deadline for submission will be uploaded separately. Teams have to submit the individual report as per the format. In case team submitting report in any other format will also be penalized.

Teams submitting the report will be considered final and will be used for evaluation during main event. Teams will not be allowed to make any changes in report after submitting the report as per the deadlines.

The reports will be evaluated during main event. In case any report found in any other format or any changes found from the submitted report, teams will be penalized based on the severity of error.

## **ARTICLE 9: PROTESTS**

**A9.1** It is recognized that thousands of hours of work have gone into fielding a vehicle and that teams are entitled to all the points they can earn. We also recognize that there can be differences in the interpretation of rules, the application of penalties and the understanding of procedures. The officials and SAEINDIA staff will make every effort to fully review all questions and resolve problems and discrepancies quickly and equitably

### **A9.2 Preliminary Review - Required**

If a team has a question about scoring, judging, policies or any official action it must be brought to the organizers or SAEINDIA staff's attention for an informal preliminary review before a protest can be filed.

### **A9.3 Cause for Protest**

A team may protest any rule interpretation, score or official action (unless specifically excluded from protest) which they feel has caused some actual, non-trivial, harm to their team, or has had a substantive effect on their score. Teams may not protest rule interpretations or actions that have not caused them any substantive damage.

### **A9.4 Protest Format and Forfeit**

All protests must be filed in writing and presented to the organizer or SAEINDIA staff by the team captain. In order to have a protest considered, a team must post a twenty-five (25) point protest bond which will be forfeited if their protest is rejected.

### **A9.5 Protest Period**

Protests concerning any aspect of the competition must be filed within one-half hour (30 minutes) of the posting of the scores of the event to which the protest relates.

### **A9.6 Decision**

The decision of the competition protest committee regarding any protest is final.

## **ARTICLE 10: QUESTIONS ABOUT THE STUDENT FORMULA RULES**

### **A10.1 Question Publication**

By submitting a question to the STUDENT FORMULA Rules Committee or the competition's organizing body you and your team agree that both your question and the official answer can be reproduced and distributed by SAEINDIA, in both complete and edited versions, in any medium or format anywhere in the world.

### **A10.2 Question Types**

The Committee will answer questions that are not already answered in the rules or FAQs or that require new or novel rule interpretations. The Committee will not respond to questions that are already answered in the rules. For example, if a rule specifies a minimum dimension for a part the Committee will not answer questions asking if a smaller dimension can be used.

### **A10.4 Question Format**

A10.4.1 All rules questions must include (1) the full name and email address of the student submitting the question, (2) the name of the university - no abbreviations, (3) the number of the applicable rule and (4) the specific competition your team has, or is planning to, enter.

A10.4.2 The following limits apply to questions submitted to the STUDENT FORMULA Rules Committee (1) No photograph, drawing or other attachment may exceed 500 KB in size (2) the total size of any question, with all attachments, must not exceed 2 MB.

### **A10.5 Response Time**

A10.5.1 Please allow a minimum of two (2) weeks for a response. The Rules Committee will respond as quickly as possible, however responses to questions presenting new issues, or of unusual complexity, may take more than two weeks.

A10.5.2 Please do not resend questions.

### **A10.6 Submission Addresses:**

A10.6.1 Teams entering STUDENT FORMULA competitions in INDIA:  
Follow the current submission instructions published on [www.suprasaeindia.org](http://www.suprasaeindia.org).



---

## APPENDIX S - SAE TECHNICAL STANDARDS

The SAEINDIA has made the following SAE Technical Standards available on line, **at no cost**, for use by Collegiate Design teams. Standards are important in all areas of engineering and we urge you to review these documents and to become familiar with their contents and use.

The technical documents listed below include both (1) standards that are identified in the rules and (2) standards that the TSB and the various rules committees believe are valuable references or which may be mentioned in future rule sets.

All Collegiate Design Series teams registered for competition have access to all the standards listed below - including standards not specific to your competition.

### **STUDENT FORMULA**

SAE 4130 steel is referenced but no specific standard is identified

SAE Grade 5 bolts are required but no specific standard is identified

#### **Standards Relevant to STUDENT FORMULA**

J183 - Engine Oil Performance and Engine Service Classification - Standard

J306 - Automotive Gear Lubricant Viscosity Classification - Standard

J429 - Mechanical and Material Requirements for Externally Threaded Fasteners - Standard

J452 - General Information - Chemical Compositions, Mechanical and Physical Properties of SAE Aluminum Casting Alloys - Information Report

J512 - Automotive Tube Fittings - Standard

J517 - Hydraulic Hose - Standard

J637 - Automotive V-Belt Drives - Recommended

Practice J829 - Fuel Tank Filler Cap and Cap Retainer

J1153 - Hydraulic Cylinders for Motor Vehicle Brakes - Test Procedure

J1154 - Hydraulic Master Cylinders for Motor Vehicle Brakes - Performance Requirements - Standard

J1703 - Motor Vehicle Brake Fluid - Standard

J2045 - Performance Requirements for Fuel System Tubing Assemblies - Standard J2053 -

Brake Master Cylinder Plastic Reservoir Assembly for Road Vehicles – Standard

#### **Standard Relevant to all CDS Competitions**

J1739 - Potential Failure Mode and Effects Analysis in Design (Design FMEA) Potential Failure Mode and Effects Analysis in Manufacturing and Assembly Processes (Process FMEA) and Potential Failure Mode and Effects Analysis for Machinery (Machinery FMEA)

---

**2018 STUDENT FORMULA RULES**

**PART T - GENERAL TECHNICAL REQUIREMENTS**

**ARTICLE 1: VEHICLE REQUIREMENTS & RESTRICTIONS**

**T1.1 Technical Inspection**

The following requirements and restrictions will be enforced through technical inspection. Non-compliance must be corrected and the car re-inspected before the car is allowed to operate under power.

**T1.2 Modifications and Repairs**

T1.2.1 Once the vehicle has been presented for judging in the Cost or Design Events or submitted for Technical Inspection, and until the vehicle is approved to compete in the dynamic events, i.e. all the three inspection stickers are awarded, the only modifications permitted to the vehicle are those directed by the Inspector(s) and noted on the Inspection Form.

T1.2.2 Once the vehicle is approved to compete in the dynamic events, the **ONLY** modifications permitted to the vehicle are those listed below. They are also referenced in Part S of the STUDENT FORMULA Rules -Static Event Regulations.

- a. Adjustment of belts chains and clutches.
- b. Adjustment of brake bias.
- c. Adjustment of the driver restraint system, head restraint, seat and pedal assembly.
- d. Substitution of the head restraint or seat insert for different drivers.
- e. Adjustment to engine operating parameters, e.g. fuel mixture and ignition timing, and any software calibrating changes.
- f. Adjustment of mirrors.
- g. Adjustment of the suspension where no part substitution is required, (except that springs, sway bars and shims may be changed).
- h. Adjustment of tire pressure
- i. Adjustment of wing angle, but not the location
- j. Replenishment of fluids
- k. Replacement of worn tires or brake pads
- m. Recharging low voltage batteries

T1.2.3 The vehicle must maintain all required specifications, e.g. ride height, suspension travel, braking capacity, sound level and wing location throughout the competition.

T1.2.4 Once the vehicle is approved for competition, any damage to the vehicle that requires repair, e.g. crash damage, electrical or mechanical damage will void the Inspection Approval. Upon the completion of the repair and before re-entering into any dynamic competition, the vehicle MUST be re-submitted to Technical Inspection for re-approval.

**ARTICLE 2: GENERAL DESIGN REQUIREMENTS**

**T2.1 Vehicle Configuration**

The vehicle must be open-wheeled and open-cockpit (a formula style body) with four (4) wheels that are not in a straight line.

Definition of "Open Wheel" - Open Wheel vehicles must satisfy all of the following criteria:

- 1) The top 180 degrees of the wheels/tires must be unobstructed when viewed 68.6mm (2.7 inches) above the plane formed by the tops of the front and rear tires.
- 2) The wheels/tires must be unobstructed when viewed from the side.
- 3) No part of the vehicle may enter a keep-out-zone defined as a circle 68.6mm (2.7 inches) larger radially than the outside diameter of the tire with the tires steered straight ahead with a 77kg (170 pound) driver seated in the normal driving position. The inner sidewall of the tire (vehicle side) is not included in this assessment. See the figure below.

Note: The dry tires will be used for all inspections. For technical inspection the keep-out-zone may be inspected by use of a tennis ball fastened to the end of a stick. The ball will have the 68.6mm (2.7 inches) diameter and must be able to be freely moved around the outside of the tire without contacting any portion of the car other than the tire.

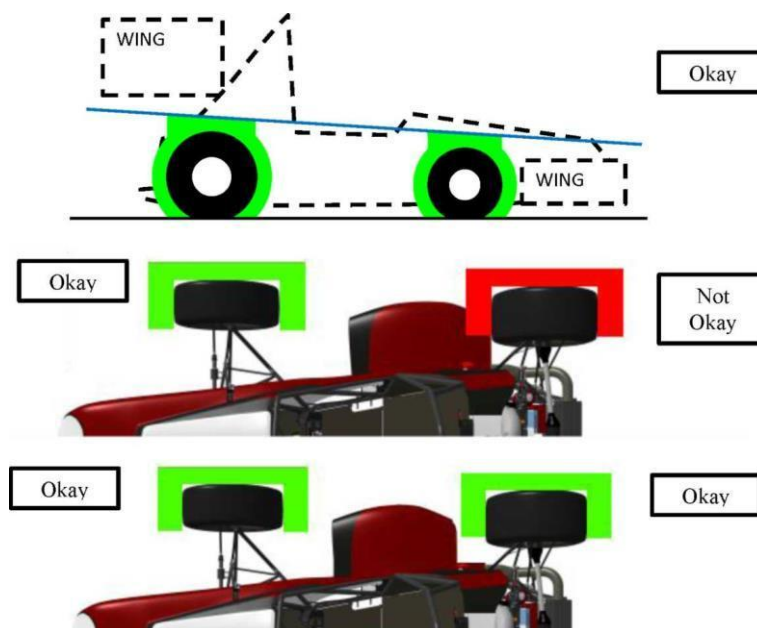

**T2.2 Bodywork**

There must be no openings through the bodywork into the driver compartment from the front of the vehicle back to the roll bar main hoop or firewall other than that required for the cockpit opening. Minimal openings around the front suspension components are allowed.

**T2.3 Wheelbase**

The car must have a wheelbase of at least 1525 mm (60 inches). The wheelbase is measured from the center of ground contact of the front and rear tires with the wheels pointed straight ahead.

**T2.4 Vehicle Track**

The smaller track of the vehicle (front or rear) must be no less than 75% of the larger track.

**T2.5 Visible Access**

All items on the Inspection Form must be clearly visible to the technical inspectors without using instruments such as endoscopes or mirrors. Visible access can be provided by removing body panels or by providing removable access panels.

**T2.6 DESIGN COMPETITION**

The design report submitted by teams prior to the main event should be 100% in compliance with the vehicle presented during main event.

**ARTICLE 3: DRIVER'S CELL**

**T3.1 Vehicle Structure - 2 Options**

Teams may, at their option, design their vehicle to comply with either of two (2) separate, but related, sets of requirements and restrictions. Specifically, teams may elect to comply with **either**:

Part T Article 3 "Drivers Cell" as defined below .

**T3.2 General Requirements**

Among other requirements, the vehicle's structure must include two roll hoops that are braced, a front bulkhead with support system and Impact Attenuator, and side impact structures.

**T3.3 Definitions:**The following definitions apply throughout the Rules document:

**Frame members**

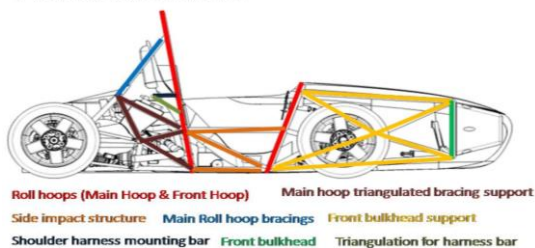

- Main Hoop - A roll bar located alongside or just behind the driver's torso.
- Front Hoop - A roll bar located above the driver's legs, in proximity to the steering wheel.
- Roll Hoops - Both the Front Hoop and the Main Hoop are classified as "Roll Hoops"
- Roll Hoop Bracing Supports - The structure from the lower end of the Roll Hoop Bracing back to the Roll Hoop(s).
- Frame Member - A minimum representative single piece of uncut, continuous tubing.
- Frame - The "Frame" is the fabricated structural assembly that supports all functional vehicle systems. This assembly may be a single welded structure, multiple welded structures or a combination of composite and welded structures.
- Primary Structure - The Primary Structure is comprised of the following Frame components: 1) Main Hoop, 2) Front Hoop, 3) Roll Hoop Braces and Supports, 4) Side Impact Structure, 5) Front Bulkhead, 6) Front Bulkhead Support System and 7) all Frame Members, guides and supports that transfer load from the Driver's Restraint System into items 1 through 6.
- Major Structure of the Frame - The portion of the Frame that lies within the envelope defined by the Primary Structure. The upper portion of the Main Hoop and the Main Hoop *Bracing* are not included in defining this envelope.
- Front Bulkhead - A planar structure that defines the forward plane of the Major Structure of the Frame and functions to provide protection for the driver's feet.
- Impact Attenuator - A deformable, energy absorbing device located forward of the Front Bulkhead.
- Side Impact Zone - The area of the side of the car extending from the top of the floor to 350 mm (13.8 inches) above the ground and from the Front Hoop back to the Main Hoop.
- Node-to-node triangulation - An arrangement of frame members projected onto a plane, where a co-planar load applied in any direction, at any node, results in only tensile or compressive forces in the frame members. This is also what is meant by "properly triangulated".

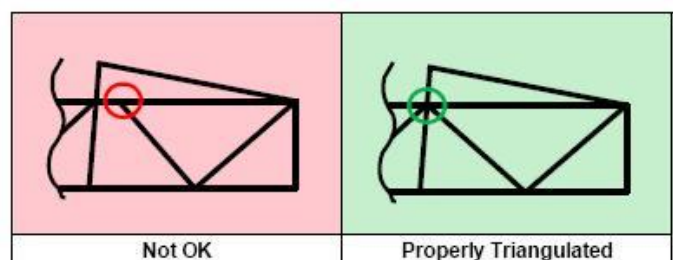

### T3.4 Minimum Material Requirements

#### T3.4.1 Baseline Steel Material

The Primary Structure of the car must be constructed of:

Either: Round, mild or alloy, steel tubing (minimum 0.1% carbon) of the minimum dimensions specified in the following table,

Or: Approved alternatives per Rules T3.4, T3.5, T3.6 and T3.7.

1. . "Only seamless pipe to be used."

ITEM or APPLICATION	OUTSIDE DIMENSION X WALL THICKNESS
Main & Front Hoops, Shoulder Harness Mounting Bar	Round 1.0 inch (25.4 mm) x 0.095 inch (2.4 mm) or Round 25.0 mm x 2.50 mm metric
Side Impact Structure, Front Bulkhead, Roll Hoop Bracing, Driver's Restraint Harness Attachment (except as noted above)	Round 1.0 inch (25.4 mm) x 0.065 inch (1.65 mm) or Round 25.0 mm x 1.75 mm metric or Round 25.4 mm x 1.60 mm metric or Square 1.00 inch x 1.00 inch x 0.049 inch or Square 25.0 mm x 25.0 mm x 1.25 mm metric or Square 26.0 mm x 26.0 mm x 1.2 mm metric
Front Bulkhead Support, Main Hoop Bracing Supports	Round 1.0 inch (25.4 mm) x 0.049 inch (1.25 mm) or Round 25.0 mm x 1.5 mm metric or Round 26.0 mm x 1.2 mm metric

Note 1: The use of alloy steel does not allow the wall thickness to be thinner than that used for mild steel.

Note 2: For a specific application:

- Using tubing of the specified outside diameter but with greater wall thickness,
- **Or** of the specified wall thickness and a greater outside diameter,
- **Or** replacing round tubing with square tubing of the same or larger size to those listed above, Are NOT rules deviation requiring approval.

Note 3: Except for inspection holes, any holes drilled in any regulated tubing require the submission of an SES.

Note 4: Baseline steel properties used for calculations to be submitted in an SES may not be lower than the following:

Bending and buckling strength calculations:

Young's Modulus (E) = 200 GPa (29,000 ksi)

Yield Strength (Sy) = 305 MPa (44.2 ksi)

Ultimate Strength (Su) = 365 MPa (52.9 ksi)

Welded tube joint calculations:

Yield Strength (Sy) = 180 MPa (26ksi)

Ultimate Strength ( $S_u$ ) = 300 MPa (43.5 ksi).

Where welded tubing reinforcements are required (e.g. inserts for bolt holes or material to support suspension cutouts) the tubing **must** retain the baseline cold rolled strength while using the welded strength for the additional reinforcement material.

### T3.5 Alternative Tubing and Material - General

T3.5.1 Alternative tubing geometry and/or materials may be used except that the Main Roll Hoop and Main Roll Hoop Bracing must be made from steel, i.e. the use of aluminum or titanium tubing or composites for these components is prohibited.

T3.5.2 Titanium or magnesium on which welding has been utilized may not be used for any part of the Primary Structure. This includes the attachment of brackets to the tubing or the attachment of the tubing to other components.

T3.5.3 If a team chooses to use alternative tubing and/or materials they must submit a "Structural Equivalency Spreadsheet" per Rule T3.9. The teams must submit calculations for the material they have chosen, demonstrating equivalence to the minimum requirements found in Section T3.4.1 for yield and ultimate strengths in bending, buckling and tension, for buckling modulus and for energy dissipation. (The Buckling Modulus is defined as  $EI$ , where,  $E$  = modulus of Elasticity, and  $I$  = area moment of inertia about the weakest axis.)

T3.5.4 Tubing cannot be of thinner wall thickness than listed in T3.6 or T3.7.

T3.5.5 If a bent tube is used anywhere in the primary structure, other than the front and main roll hoops, an additional tube must be attached to support it. The attachment point must be the position along the tube where it deviates farthest from a straight line connecting both ends. The support tube must have the same diameter and thickness as the bent tube. The support tube must terminate at a node of the chassis.

*Note: It is allowable for the properties of tubes and laminates to be combined to prove equivalence. E.g. in a side-impact structure consisting of one tube as per T3.4 and a laminate panel, the panel only needs to be equivalent to two side-impact tubes.*

### T3.6 Alternative Steel Tubing

Minimum Wall Thickness Allowed:

MATERIAL & APPLICATION	MINIMUM WALL THICKNESS
Steel Tubing for Front and Main Roll Hoops, and Shoulder Harness Mounting Bar	2.0 mm (0.079 inch)
Steel Tubing for Roll Hoop Bracing, Roll Hoop Bracing Supports, Side Impact Structure, Front Bulkhead, Front	1.2 mm (0.047 inch)

Bulkhead Support, Driver's Harness Attachment (except as noted above).	
--	--

Note 1: All steel is treated equally - there is no allowance for alloy steel tubing, e.g. SAE 4130, to have a thinner wall thickness than that used with mild steel.

Note 2: To maintain EI with a thinner wall thickness than specified in T3.4.1, the outside diameter **MUST** be increased.

Note 3: To maintain the equivalent yield and ultimate tensile strength the same cross-sectional area of steel as the baseline tubing specified in T3.4.1 **MUST** be maintained.

### **T3.7 Aluminum Tubing Requirements**

T3.7.1 Minimum Wall Thickness: Aluminum Tubing 3.0 mm (0.118 inch)

T3.7.2 The equivalent yield strength must be considered in the "as-welded" condition, (Reference: WELDING ALUMINUM (latest Edition) by the Aluminum Association, or THE WELDING HANDBOOK, Volume 4, 7th Ed., by The American Welding Society), unless the team demonstrates and shows proof that the frame has been properly solution heat treated and artificially aged.

T3.7.3 Should aluminum tubing be solution heat-treated and age hardened to increase its strength after welding; the team must supply sufficient documentation as to how the process was performed. This includes, but is not limited to, the heat-treating facility used, the process applied, and the fixturing used.

### **T3.8 Composite Materials**

T3.8.1 If any composite or other material is used, the team must present documentation of material type, e.g. purchase receipt, shipping document or letter of donation, and of the material properties. Details of the composite lay-up technique as well as the structural material used (cloth type, weight, and resin type, number of layers, core material, and skin material if metal) must also be submitted. The team must submit calculations demonstrating equivalence of their composite structure to one of similar geometry made to the minimum requirements found in Section T3.4.1. Equivalency calculations must be submitted for energy dissipation, yield and ultimate strengths in bending, buckling, and tension. Submit the completed "Structural Equivalency Spreadsheet" per Section T3.9.

T3.8.2 Composite materials are not allowed for the Main Hoop or the Front Hoop.

### **T3.9 Structural Documentation - SES Submission**

All equivalency calculations must prove equivalency relative to steel grade SAE/AISI 1010.

T3.9.1 All teams **MUST** submit a STRUCTURAL EQUIVALENCY SPREADSHEET (SES).



Teams complying with the Part T Article 3 "Drivers Cell" rules MUST submit a Structural Equivalence Spreadsheet (SES), even if they are NOT planning to use alternative materials or tubing sizes to those specified in T3.4.1 Baseline Steel Materials.

T3.9.2 the use of alternative materials or tubing sizes to those specified in T3.4.1 "Baseline Steel Material," is allowed, provided they have been judged by a technical review to have equal or superior properties to those specified in T3.4.1.

T3.9.3 Approval of alternative material or tubing sizes will be based upon the engineering judgment and experience of the chief technical inspector or his appointee.

T3.9.4 The technical review is initiated by completing the "Structural Equivalency Spreadsheet" (SES) using the format given in Appendix T-1.

T3.9.5 Structural Equivalency Spreadsheet - Submission

- a. Address - SESs must be submitted to the officials at the competition you are entering at the address shown in the Appendix or indicated on the competition website.
- b. Due Date - SESs must be submitted no later than the date indicated on the competition website. Teams that submit their Structural Equivalency Spreadsheet after the due date for the competition will be penalized 10 points per day up to a maximum of 50 points, which will be taken off the team's Total Score.

**Do Not Resubmit SES's unless instructed to do so.**

T3.9.6 Vehicles completed under an approved SES must be fabricated in accordance with the materials and processes described in the SES.

T3.9.7 Teams must bring a copy of the approved SES with them to Technical Inspection.

**Comment** - The resubmission of an SES that was written and submitted for a competition in a previous year is strongly discouraged. Each team is expected to perform their own tests and to submit SESs based on their original work. Understanding the engineering that justifies the equivalency is essential to discussing your work with the officials.

**T3.10 Main and Front Roll Hoops - General Requirements**

T3.10.1 The driver's head and hands must not contact the ground in any rollover attitude.

T3.10.2 The Frame must include both a Main Hoop and a Front Hoop as shown in Figure 1.

**HELMET CLEARANCE**

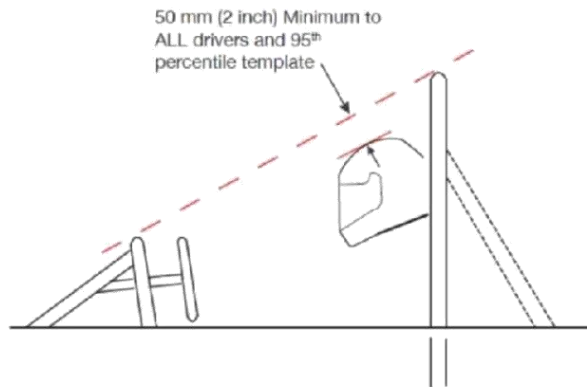

FIGURE 1a

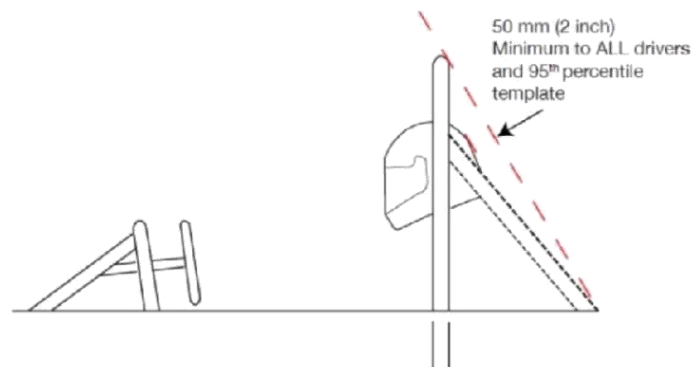

FIGURE 1b

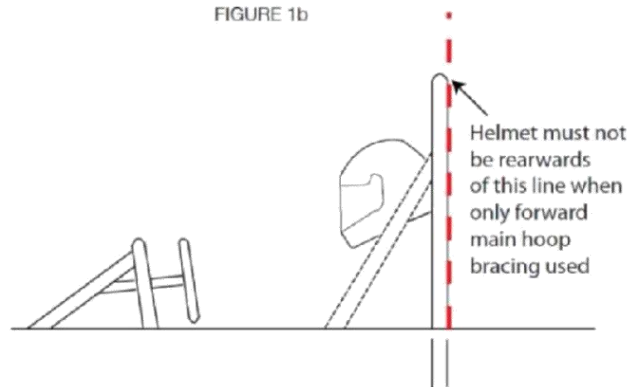

FIGURE 1c

T3.10.3 When seated normally and restrained by the Driver's Restraint System, the helmet of a 95th percentile male (anthropometrical data) and all of the team's drivers must:

- a. Be a minimum of 50.8 mm (2 inches) from the straight line drawn from the top of the main hoop to the top of the front hoop. (Figure 1a)
- b. Be a minimum of 50.8 mm (2 inches) from the straight line drawn from the top of the main hoop to the lower end of the main hoop bracing if the bracing extends rearwards. (Figure 1b)
- c. Be no further rearwards than the rear surface of the main hoop if the main hoop bracing extends forwards. (Figure 1c)

### 95th Percentile Male Template Dimensions

A two dimensional template used to represent the 95th percentile male is made to the following dimensions:

- A circle of diameter 200 mm (7.87 inch) will represent the hips and buttocks.
- A circle of diameter 200 mm (7.87 inch) will represent the shoulder/cervical region.
- A circle of diameter 300 mm (11.81 inch) will represent the head (with helmet).
- A straight line measuring 490 mm (19.29 inch) will connect the centers of the two 200 mm circles.
- A straight line measuring 280 mm (11.02 inch) will connect the centers of the upper 200 mm circle and the 300 mm head circle.

T3.10.4 The 95th percentile male template will be positioned as follows: (See Figure 2.)

- The seat will be adjusted to the rearmost position,
- The pedals will be placed in the most forward position.
- The bottom 200 mm circle will be placed on the seat bottom such that the distance between the center of this circle and the rearmost face of the pedals is no less than 915 mm (36 inches).
- The middle 200 mm circle, representing the shoulders, will be positioned on the seat back.
- The upper 300 mm circle will be positioned no more than 25.4 mm (1 inch) away from the head restraint (i.e. where the driver's helmet would normally be located while driving).

"Percy" – 95th Percentile Male with Helmet

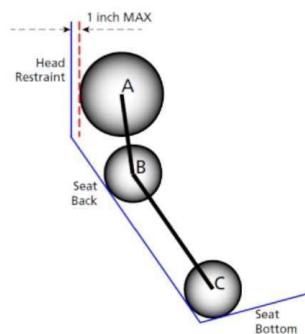

Circle A = Head with helmet – 300 mm diameter  
 Circle B = Shoulders – 200 mm diameter  
 Circle C = Hips and buttocks – 200 mm diameter

Line A-B = 280 mm from centerpoint to centerpoint  
 Line B-C = 490 mm from centerpoint to centerpoint

**FIGURE 2**

T3.10.5 If the requirements of T3.10.4 are not met with the 95<sup>th</sup> percentile male template, the car will NOT receive a Technical Inspection Sticker and will not be allowed to compete in the dynamic events.

T3.10.6 Drivers who do not meet the helmet clearance requirements of T3.10.3 will not be allowed to drive in the competition.

T3.10.7 The minimum radius of any bend, measured at the tube centerline, must be at least three times the tube outside diameter. Bends must be smooth and continuous with no evidence of crimping or wall failure.

T3.10.8 The Main Hoop and Front Hoop must be securely integrated into the Primary Structure using gussets and/or tube triangulation.

### **T3.11 Main Hoop**

T3.11.1 The Main Hoop must be constructed of a single piece of uncut, continuous, closed section steel tubing per Rule T3.4.1.

T3.11.2 The use of aluminum alloys, titanium alloys or composite materials for the Main Hoop is prohibited.

T3.11.3 The Main Hoop must extend from the lowest Frame Member on one side of the Frame, up, over and down to the lowest Frame Member on the other side of the Frame.

T3.11.4 In the side view of the vehicle, the portion of the Main Roll Hoop that lies above its attachment point to the Major Structure of the Frame must be within ten degrees (10°) of the vertical.

T3.11.5 In the side view of the vehicle, any bends in the Main Roll Hoop above its attachment point to the Major Structure of the Frame must be braced to a node of the Main Hoop Bracing Support structure with tubing meeting the requirements of Roll Hoop Bracing as per Rule T3.4.1.

T3.11.6 In the front view of the vehicle, the vertical members of the Main Hoop must be at least 380 mm (15 inch) apart (inside dimension) at the location where the Main Hoop is attached to the Major Structure of the Frame.

### **T3.12 Front Hoop**

T3.12.1 The Front Hoop must be constructed of closed section metal tubing per Rule T3.4.1.

T3.12.2 The Front Hoop must extend from the lowest Frame Member on one side of the Frame, up, over and down to the lowest Frame Member on the other side of the Frame.

T3.12.3 With proper gusseting and/or triangulation, it is permissible to fabricate the Front Hoop from more than one piece of tubing.

T3.12.4 The top-most surface of the Front Hoop must be no lower than the top of the steering wheel in any angular position.

T3.12.5 The Front Hoop must be no more than 250 mms (9.8 inches) forward of the steering wheel. This distance shall be measured horizontally, on the vehicle centerline, from the rear surface of the Front Hoop to the forward most surface of the steering wheel rim with the steering in the straight-ahead position.

T3.12.6 In side view, no part of the Front Hoop can be inclined at more than twenty degrees (20°) from the vertical.

### T3.13 Main Hoop Bracing

T3.13.1 Main Hoop braces must be constructed of closed section steel tubing per Rule T3.4.1.

T3.13.2 The Main Hoop must be supported by two braces extending in the forward or rearward direction on both the left and right sides of the Main Hoop.

T3.13.3 In the side view of the Frame, the Main Hoop and the Main Hoop braces must not lie on the same side of the vertical line through the top of the Main Hoop, i.e. if the Main Hoop leans forward, the braces must be forward of the Main Hoop, and if the Main Hoop leans rearward, the braces must be rearward of the Main Hoop.

T3.13.4 The Main Hoop braces must be attached as near as possible to the top of the Main Hoop but not more than 160 mm (6.3 in) below the top-most surface of the Main Hoop. The included angle formed by the Main Hoop and the Main Hoop braces must be at least thirty degrees (30°). See Figure 3.

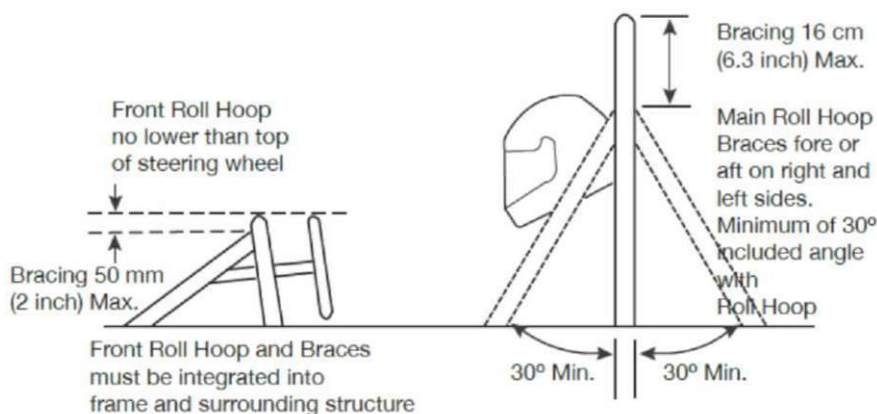

FIGURE 3

T3.13.5 The Main Hoop braces must be straight, i.e. without any bends.

T3.13.6 the attachment of the Main Hoop braces must be capable of transmitting all loads from the Main Hoop into the Major Structure of the Frame without failing. From the lower end of the braces there must be a properly triangulated structure back to the lowest part of the Main Hoop and the node at which the upper side impact tube meets the Main Hoop. This

structure must meet the minimum requirements for Main Hoop Bracing Supports (see Rule T3.4) or an SES approved alternative. Bracing loads must not be fed solely into the engine, transmission or differential, or through suspension components.

T3.13.7 If any item which is outside the envelope of the Primary Structure is attached to the Main Hoop braces, then additional bracing must be added to prevent bending loads in the braces in any rollover attitude.

### **T3.14 Front Hoop Bracing**

T3.14.1 Front Hoop braces must be constructed of material per Rule T3.4.1.

T3.14.2 The Front Hoop must be supported by two braces extending in the forward direction on both the left and right sides of the Front Hoop.

T3.14.3 The Front Hoop braces must be constructed such that they protect the driver's legs and should extend to the structure in front of the driver's feet.

T3.14.4 The Front Hoop braces must be attached as near as possible to the top of the Front Hoop but not more than 50.8 mm (2 in) below the top-most surface of the Front Hoop. See Figure 3.

T3.14.5 If the Front Hoop leans rearwards by more than ten degrees ( $10^\circ$ ) from the vertical, it must be supported by additional bracing to the rear. This bracing must be constructed of material per Rule T3.4.1.

### **T3.15 Other Bracing Requirements**

Where the braces are not welded to steel Frame Members, the braces must be securely attached to the Frame using 8 mm Metric Grade 8.8 (5/16 in SAE Grade 5), or stronger, bolts. Mounting plates welded to the Roll Hoop braces must be at least 2.0 mm (0.080 in) thick steel.

### **T3.16 Other Side Tube Requirements**

If there is a Roll Hoop brace or other frame tube alongside the driver, at the height of the neck of any of the team's drivers, a metal tube or piece of sheet metal must be firmly attached to the Frame to prevent the drivers' shoulders from passing under the roll hoop brace or frame tube, and his/her neck contacting this brace or tube.

### **T3.17 Mechanically Attached Roll Hoop Bracing**

T3.17.1 Roll Hoop bracing may be mechanically attached.

T3.17.2 Any non-permanent joint at either end must be either a double-lug joint as shown in Figures 4 and 5, or a sleeved butt joint as shown in Figure 6.

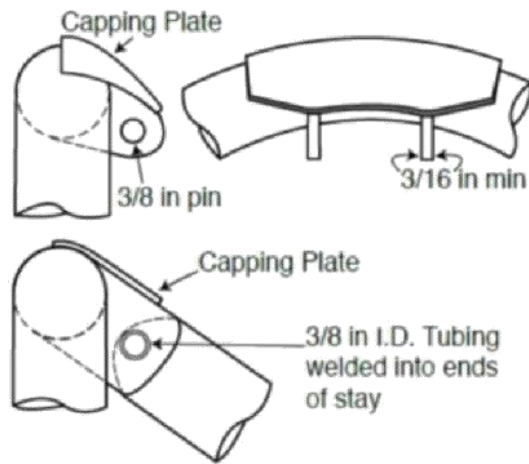

FIGURE 4

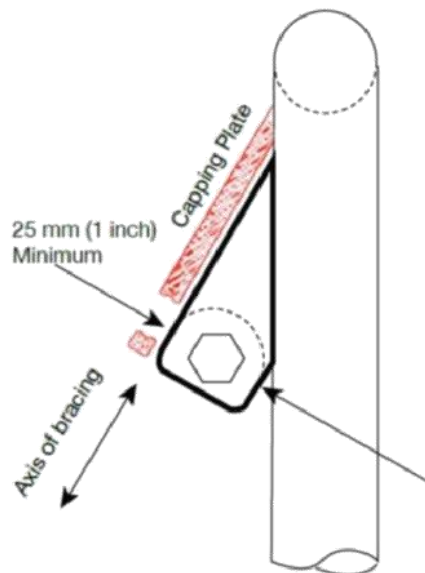

FIGURE 5

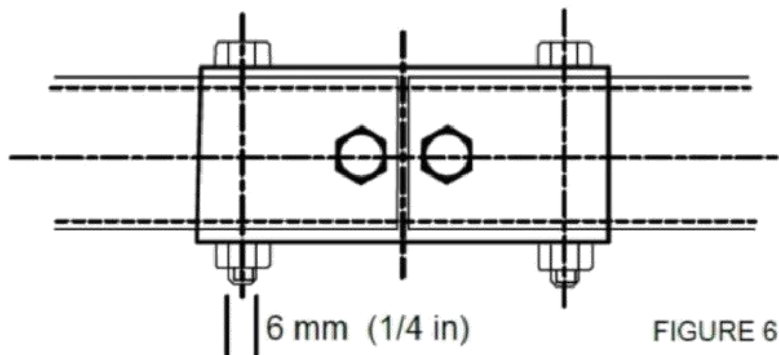

FIGURE 6

T3.17.3 The threaded fasteners used to secure non-permanent joints are considered critical fasteners and must comply with ARTICLE 11.

T3.17.4 No spherical rod ends are allowed.

T3.17.5 For double-lug joints, each lug must be at least 4.5 mm (0.177 in) thick steel, measure 25 mm (1.0 in) minimum perpendicular to the axis of the bracing and be as short as practical along the axis of the bracing.

T3.17.6 All double-lug joints, whether fitted at the top or bottom of the tube, must include a capping arrangement (Figures 4 & 5).

T3.17.7 In a double-lug joint the pin or bolt must be 10 mm Metric Grade 9.8 (3/8 in. SAE Grade 8) minimum. The attachment holes in the lugs and in the attached bracing must be a close fit with the pin or bolt.

T3.17.8 For sleeved butt joints (Figure 6), the sleeve must have a minimum length of 76 mm (3 inch); 38 mm (1.5 inch) either side of the joint, and be a close-fit around the base tubes. The wall thickness of the sleeve must be at least that of the base tubes. The bolts must be 6 mm Metric Grade 9.8 (1/4 inch SAE Grade 8) minimum. The holes in the sleeves and tubes must be a close-fit with the bolts.

### **T3.18 Frontal Impact Structure**

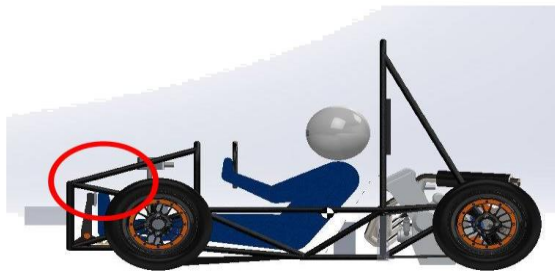

Driver's feet must be completely inside the frame structure

T3.18.1 The driver's feet *and legs* must be completely contained within the Major Structure of the Frame. While the driver's feet are touching the pedals, in side and front views no part of the driver's feet *or legs* can extend above or outside of the Major Structure of the Frame.

T3.18.2 Forward of the Front Bulkhead must be an energy-absorbing Impact Attenuator.

### **T3.19 Bulkhead**

T3.19.1 The Front Bulkhead must be constructed of closed section tubing per Rule T3.4.1.

T3.19.2 Except as allowed by T3.19.3, The Front Bulkhead must be located forward of all non-crushable objects, e.g. batteries, master cylinders, hydraulic reservoirs.

T3.19.3 The Front Bulkhead must be located such that the soles of the driver's feet, when touching



but not applying the pedals, are rearward of the bulkhead plane. (This plane is defined by the forward-most surface of the tubing.) Adjustable pedals must be in the forward most position.

### **T3.20 Front Bulkhead Support**

T3.20.1 The Front Bulkhead must be securely integrated into the Frame.

T3.20.2 The Front Bulkhead must be supported back to the Front Roll Hoop by a minimum of three (3) Frame Members on each side of the vehicle with one at the top (within 50.8 mm (2

---

inches) of its top-most surface), one (1) at the bottom, and one (1) as a diagonal brace to provide triangulation.

T3.20.3 The triangulation must be node-to-node, with triangles being formed by the Front Bulkhead, the diagonal and one of the other two required Front Bulkhead Support Frame Members.

T3.20.4 All the Frame Members of the Front Bulkhead Support system listed above must be constructed of closed section tubing per Section T3.4.1.

### T3.21 Impact Attenuator

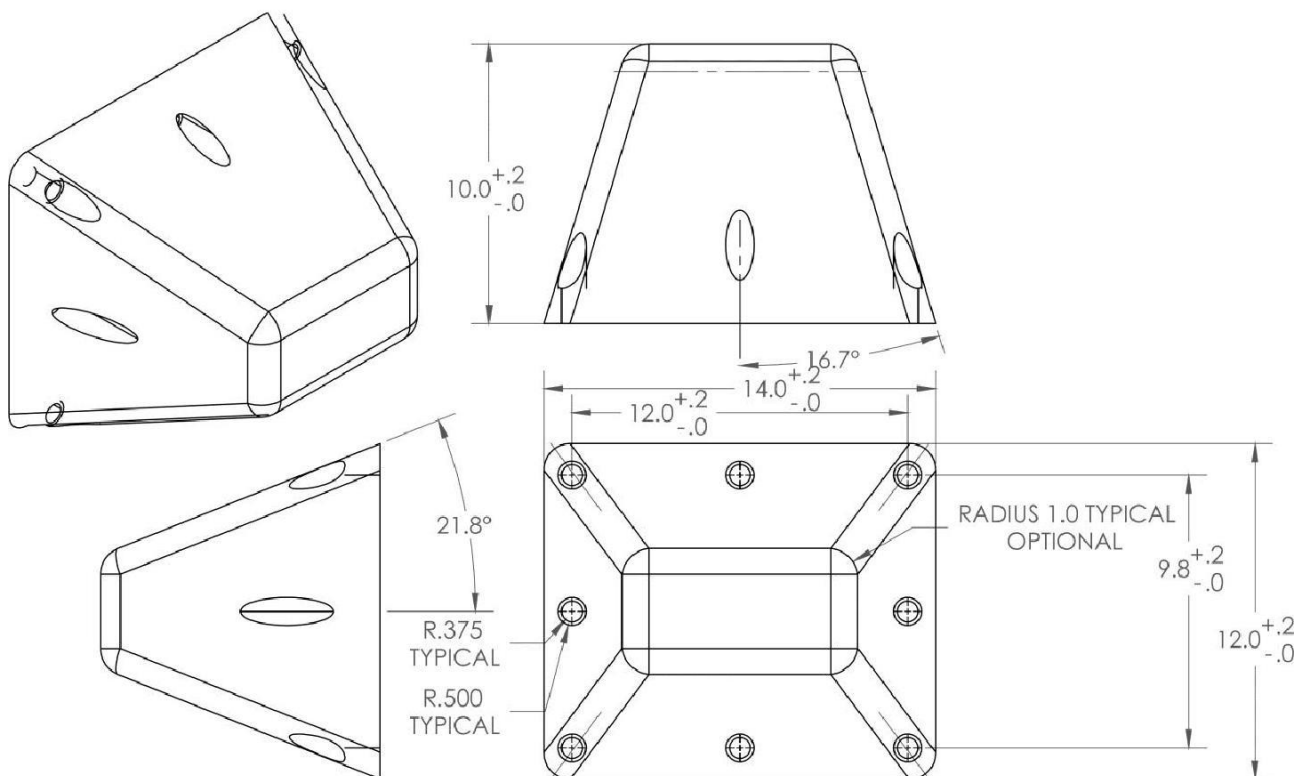
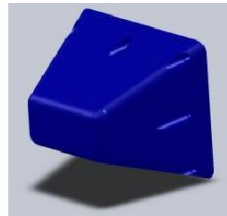

T3.21.1 The Impact Attenuator must be:

- Installed forward of the Front Bulkhead.
- At least 200 mm (7.8 in) long, with its length oriented along the fore/aft axis of the Frame.
- At least 100 mm (3.9 in) high and 200 mm (7.8 in) wide for a minimum distance of 200 mm (7.8 in) forward of the Front Bulkhead.

- d. Such that it cannot penetrate the Front Bulkhead in the event of an impact.
- e. Attached securely and directly to the Front Bulkhead and not by being part of non-structural bodywork.

T3.21.2 The attachment of the Impact Attenuator must be constructed to provide an adequate load path for transverse and vertical loads in the event of off-center and off-axis impacts.

T3.21.3 The attachment of the Impact Attenuator to a monocoque structure requires an approved "Structural Equivalency Spreadsheet" per Article T3.9 that shows equivalency to a minimum of four (4) 8 mm Grade 8.8 (5/16 inch Grade 5) bolts.

T3.21.4 On all cars, a 1.5 mm (0.060 in) solid steel or 4.0 mm (0.157 in) solid aluminum "anti-intrusion plate" must be integrated into the Impact Attenuator. If the IA plate is bolted to the Front Bulkhead, it must be the same size as the outside dimensions of the Front Bulkhead. If it is welded to the Front Bulkhead, it must extend at least to the centerline of the Front Bulkhead tubing.

T3.21.5 If the anti-intrusion plate is not integral with the frame, i.e. welded, a minimum of four (4) 8 mm Metric Grade 8.8 (5/16 inch SAE Grade 5) bolts must attach the Impact Attenuator to the Front Bulkhead.

T3.21.6 Alternative designs of the anti-intrusion plate required by T3.21.4 that do not comply with the minimum specifications given above require an approved "Structural Equivalency Spreadsheet" per Article T3.9. Equivalency must also be proven for perimeter shear strength of the proposed design.

### **T3.22 Impact Attenuator Data Requirement**

T3.22.1 The team must submit test data to show that their Impact Attenuator, when mounted on the front of a vehicle with a total mass of 300 kgs (661 lbs) and run into a solid, non-yielding impact barrier with a velocity of impact of 7.0 meters/second (23.0 ft/sec), would give an average deceleration of the vehicle not to exceed 20 g's, with a peak deceleration less than or equal to 40 g's. Total energy absorbed must meet or exceed 7350 Joules.

Note: These are the attenuator functional requirements not test requirements. Quasi-static testing is not allowed.

T3.22.2 When using acceleration data, the average deceleration must be calculated based on the raw data. The peak deceleration can be assessed based on the raw data, and if peaks above the 40g limit are apparent in the data, it can then be filtered with a Channel Filter Class (CFC) 60 (100 Hz) filter per SAE Recommended Practice J211 "Instrumentation for Impact Test", or a 100 Hz, 3rd order, lowpass Butterworth (-3dB at 100 Hz) filter.

T3.22.3 A schematic of the test method must be supplied along with photos of the attenuator before and after testing.

T3.22.4 The test piece must be presented at technical inspection for comparison to the photographs and the attenuator fitted to the vehicle.

T3.22.5 The test data and calculations must be submitted electronically in Adobe Acrobat® format (\*.pdf file) to the address and by the date provided in the Action Deadlines provided on the relevant competition website. This material must be a single file (text, drawings, data or whatever you are including).

T3.22.6 The Impact Attenuator Data must be named as follows: carnumber\_ schoolname\_ competition code\_IAD.pdf using the assigned car number, the complete school name and competition code

[Example: 087\_University of SAEINDIA\_IAD.pdf]

Competition Codes are listed in Rule A.2.6

T3.22.7 Teams that submit their Impact Attenuator Data Report after the due date will be penalized 10 points per day up to a maximum of 50 points, which will be taken off the team's Total Score.

T3.22.8 Impact Attenuator Reports will be evaluated by the organizers and the evaluations will be passed to the Design Event Captain for consideration in that event.

T3.22.9 During the test, the attenuator must be attached to the anti-intrusion plate using the intended vehicle attachment method. The anti-intrusion plate must be spaced at least 50 mm (2 inches) from any rigid surface. No part of the anti-intrusion plate may permanently deflect more than 25.4 mm (1 inch) beyond the position of the anti-intrusion plate before the test.

Note: The 25.4 mm (1 inch) spacing represents the front bulkhead support and insures that the plate does not intrude excessively into the cockpit

T3.22.10 Dynamic testing (sled, pendulum, drop tower, etc.) of the impact attenuator may only be done at a dedicated test facility. The test facility may be part of the University but must be supervised by professional staff or University faculty. Teams are not allowed to construct their own dynamic test apparatus.

T3.22.11 Standard Attenuator -

Teams may choose to use that style of impact attenuator and need not submit test data with their IAD Report. The other requirements of the IAD Report must still be submitted including, but not limited to, photos of the team's actual attenuator with evidence that it meets the design criteria given on the website.

**T3.23 Non-Crushable Objects**

T3.23.1 Except as allowed by T3.23.2, all non-crushable objects (e.g. batteries, master cylinders, hydraulic reservoirs) must be rearward of the bulkhead. No non-crushable objects are allowed in the impact attenuator zone.

T3.23.2 the front wing and wing supports may be forward of the Front Bulkhead, but may NOT be located in or pass through the Impact Attenuator. If the wing supports are in front of the Front Bulkhead, the supports must be included in the test of the Impact Attenuator for T3.22.

**T3.24 Front Bodywork**

T3.24.1 Sharp edges on the forward facing bodywork or other protruding components are prohibited.

T3.24.2 All forward facing edges on the bodywork that could impact people, e.g. the nose, must have forward facing radii of at least 38 mm (1.5 inches). This minimum radius must extend to at least forty-five degrees (45°) relative to the forward direction, along the top, sides and bottom of all affected edges.

**T3.25 Side Impact Structure for Tube Frame Cars**

The Side Impact Structure must meet the requirements listed below.

T3.25.1 The Side Impact Structure for tube frame cars must be comprised of at least three (3) tubular members located on each side of the driver while seated in the normal driving position, as shown in Figure 7.

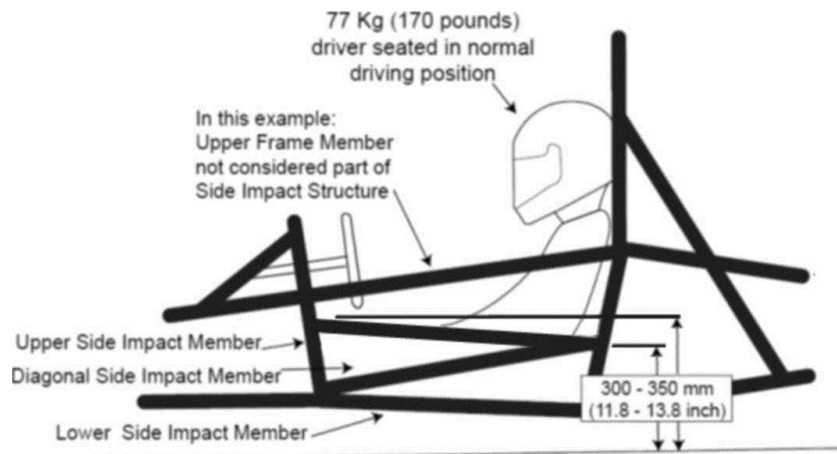

**FIGURE 7**

T3.25.2 The three (3) required tubular members must be constructed of material per Section T3.4.

T3.25.3 The locations for the three (3) required tubular members are as follows:

- The upper Side Impact Structural member must connect the Main Hoop and the Front Hoop. With a 77kg (170 pound) driver seated in the normal driving position all of the member must be at a height between 300 mm (11.8 inches) and 350 mm (13.8 inches)

above the ground. The upper frame rail may be used as this member if it meets the height, diameter and thickness requirements.

- The lower Side Impact Structural member must connect the bottom of the Main Hoop and the bottom of the Front Hoop. The lower frame rail/frame member may be this member if it meets the diameter and wall thickness requirements.
- The diagonal Side Impact Structural member must connect the upper and lower Side Impact Structural members forward of the Main Hoop and rearward of the Front Hoop.

T3.25.4 With proper gusseting and/or triangulation, it is permissible to fabricate the Side Impact Structural members from more than one piece of tubing.

T3.25.5 Alternative geometry that does not comply with the minimum requirements given above requires an approved "Structural Equivalency Spreadsheet" per Rule T3.9.

### T3.26 Inspection Holes

T3.26.1 The Technical Inspectors may check the compliance of all tubes. This may be done by the use of ultra-sonic testing or by the drilling of inspection holes at the inspector's request.

## ARTICLE 4: COCKPIT

### T4.1 Cockpit Opening

T4.1.1 In order to ensure that the opening giving access to the cockpit is of adequate size, a template shown in Figure 8 will be inserted into the cockpit opening. It will be held horizontally and inserted vertically until it has passed below the top bar of the Side Impact Structure (or until it is 350 mm (13.8 inches) above the ground for monocoque cars). No fore and aft translation of the template will be permitted during insertion.

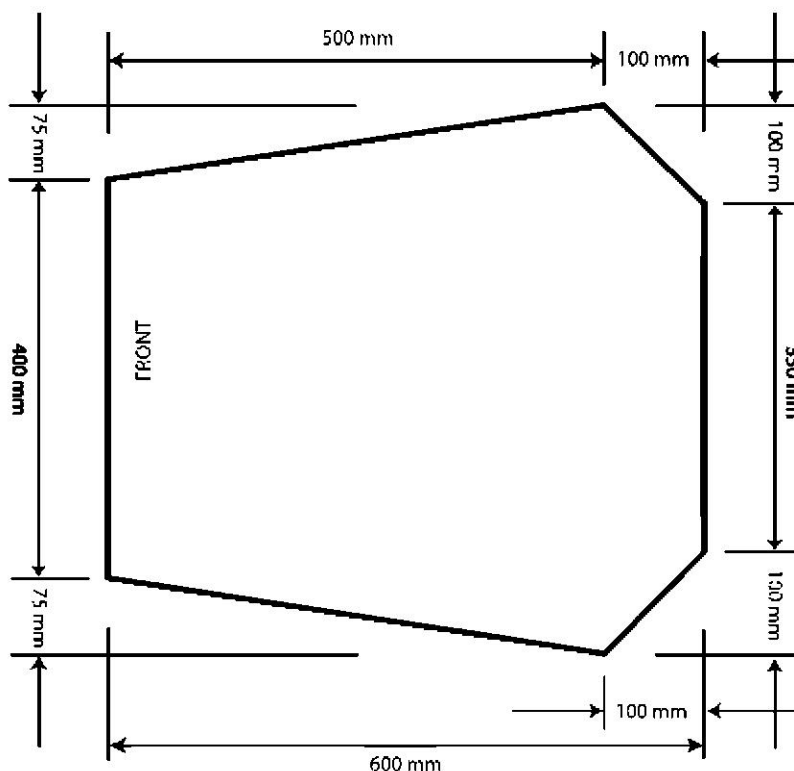

T4.1.2 During this test, the steering wheel, steering column, seat and all padding may be removed. The shifter or shift mechanism may not be removed unless it is integral with the steering wheel and is removed with the steering wheel. The firewall may not be moved or removed.

Note: As a practical matter, for the checks, the steering column will not be removed. The technical inspectors will maneuver the template around the steering column shaft, but not the steering column supports.

**T4.2 Cockpit Internal Cross Section:**

T4.2.1 A free vertical cross section, which allows the template shown in Figure 9 to be passed horizontally through the cockpit to a point 100 mm (4 inches) rearwards of the face of the rearmost pedal when in the inoperative position, must be maintained over its entire length. If the pedals are adjustable, they will be put in their most forward position.

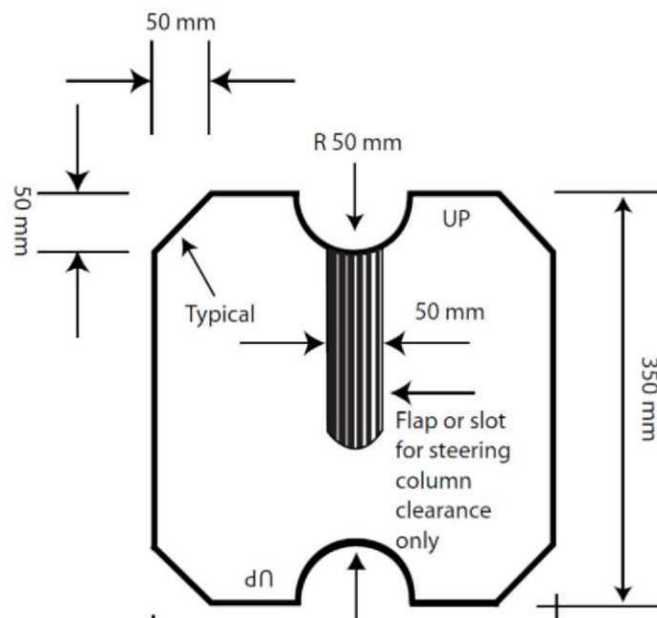

T4.2.2 The template, with maximum thickness of 7mm (0.275 inch), will be held vertically and inserted into the cockpit opening rearward of the Front Roll Hoop, as close to the Front Roll Hoop as the car's design will allow.

T4.2.3 The only items that may be removed for this test are the steering wheel, and any padding required by Rule T5.8 "Driver's Leg Protection" that can be easily removed without the use of tools with the driver in the seat. The seat may NOT be removed.

T4.2.4 Teams whose cars do not comply with T4.1.1 or T4.2.1 will not be given a Technical Inspection Sticker and will NOT be allowed to compete in the dynamic events.

Note: Cables, wires, hoses, tubes, etc. must not impede the passage of the templates required by T4.1.1 and T4.2.

### **T4.3 Driver's Seat**

T4.3.1 The lowest point of the driver's seat must be no lower than the bottom surface of the lower frame rails or by having a longitudinal tube (or tubes) that meets the requirements for Side Impact tubing, passing underneath the lowest point of the seat.

T4.3.2 When seated in the normal driving position, adequate heat insulation must be provided to ensure that the driver will not contact any metal or other materials which may become heated to a surface temperature above sixty degrees C (60°C). The insulation may be external to the cockpit or incorporated with the driver's seat or firewall. The design must show evidence of addressing all three (3) types of heat transfer, namely conduction, convection and radiation, with the following between the heat source, e.g. an exhaust pipe or coolant hose/tube and the panel that the driver could contact, e.g. the seat or floor:

- a. Conduction Isolation by:
  - i. No direct contact between the heat source and the panel, or
  - ii. A heat resistant, conduction isolation material with a minimum thickness of 8 mm (0.3 in) between the heat source and the panel.
- b. Convection Isolation by a minimum air gap of 25 mm (1 inch) between the heat source and the panel
- c. Radiation Isolation by:
  - i. A solid metal heat shield with a minimum thickness of 0.4 mm (0.015 in) or
  - ii. Reflective foil or tape when combined with a.ii above.

### **T4.4 Floor Close-out**

All vehicles must have a floor closeout made of one or more panels, which separate the driver from the pavement. If multiple panels are used, gaps between panels are not to exceed 3 mm (1/8 inch). The closeout must extend from the foot area to the firewall and prevent track debris from entering the car. The panels must be made of a solid, non-brittle material.

### **T4.5 Firewall**

T4.5.1 A firewall must separate the driver compartment from all components of the fuel supply, the engine oil, the liquid cooling systems and any high voltage system (PART EV - EV1.1). It must protect the neck of the tallest driver. It must extend sufficiently far upwards and/or rearwards such that any point less than 100 mm (4 ins.) above the bottom of the helmet of the tallest driver shall not be in direct line of sight with any part of the fuel system, the cooling system or the engine oil system.

T4.5.2 The firewall must be a non-permeable surface made from a rigid, fire resistant material.



T4.5.3 Any firewall must seal completely against the passage of fluids, especially at the sides and the floor of the cockpit, i.e. there can be no holes in a firewall through which seat belts pass.

T4.5.4 Pass-throughs for wiring, cables, etc. are allowable if grommets are used to seal the pass-throughs. Also, multiple panels may be used to form the firewall but must be sealed at the joints.

#### **T4.6 Accessibility of Controls**

All vehicle controls, including the shifter, must be operated from inside the cockpit without any part of the driver, e.g. hands, arms or elbows, being outside the planes of the Side Impact Structure defined in Rule T3.25 and T3.34.

#### **T4.7 Driver Visibility**

##### **T4.7.1 General Requirement**

The driver must have adequate visibility to the front and sides of the car. With the driver seated in a normal driving position he/she must have a minimum field of vision of two hundred degrees (200°) (a minimum one hundred degrees (100°) to either side of the driver). The required visibility may be obtained by the driver turning his/her head and/or the use of mirrors.

##### **T4.7.2 Mirrors**

If mirrors are required to meet Rule T4.7.1, they must remain in place and adjusted to enable the required visibility throughout all dynamic events.

#### **T4.8 Driver Egress**

All drivers must be able to exit to the side of the vehicle in no more than 5 seconds. Egress time begins with the driver in the fully seated position, hands in driving position on the connected steering wheel and wearing the required driver equipment. Egress time will stop when the driver has both feet on the pavement.

### **ARTICLE 5: DRIVERS EQUIPMENT (BELTS AND COCKPIT PADDING)**

#### **T5.1 Belts – General**

##### **T5.1.1 Definitions**

- a. A 5-point system - consists of a 76 mm (3 inch) wide lap belt, approximately 76 mm (3 inch) wide shoulder straps and a single approximately 51 mm (2 inch) wide anti-submarine strap. The single anti-submarine strap must have a metal-to-metal connection with the single release common to the lap belt and shoulder harness.
- b. A 6-point system - consists of a 76 mm (3 inch) wide lap belt, approximately 76 mm (3 inch) wide shoulder straps and two (2) approximately 51 mm (2 inch) wide leg or anti-submarine straps.

- c. A 7-point system - system is the same as the 6-point except it has three (3) anti-submarine straps, two (2) from the 6-point system and one (1) from the 5-point system. Note: 6 and 7-point harnesses to FIA specification 8853/98 and SFI Specification 16.5 with approximately 51 mm (2 inch) lap belts are acceptable.
- d. An "upright driving position" is defined as one with a seat back angled at thirty degrees (30°) or less from the vertical as measured along the line joining the two 200 mm circles of the template of the 95th percentile male as defined in Rule T3.10.3 and positioned per T3.10.4.
- e. A "reclined driving position" is defined as one with a seat back angled at more than thirty degrees (30°) from the vertical as measured along the line joining the two 200 mm circles of the template of the 95th percentile male as defined in Rule T3.10.3 and positioned per T3.10.4.
- f. The "chest-groin line" is the straight line that in side view follows the line of the shoulder belts from the chest to the release buckle.

#### T5.1.2 Harness Requirements

All drivers must use a 5, 6 or 7 point restraint harness meeting the following specifications:

- a. All driver restraint systems must meet SFI Specification 16.1, SFI Specification 16.5, or FIA specification 8853/98.
- b. The belts must bear the appropriate dated labels.
- c. The material of all straps must be in perfect condition.
- d. There must be a single release common to the lap belt and shoulder harness using a metal-to-metal quick release type latch.
- e. To accommodate drivers of differing builds, all lap belts must have a "quick adjuster" feature. Lap belts with "pull-up" adjusters are recommended over "pull-down" adjusters.
- f. Cars with a "reclined driving position" (see 5.1.2.f above) must have either a 6 point or 7-point harness, AND have either anti-submarine belts with "quick adjusters" or have two (2) sets of anti-submarine belts installed.
- g. The shoulder harness must be the over-the-shoulder type. Only separate shoulder straps are permitted (i.e. "y"-type shoulder straps are not allowed). The "H"-type configuration is allowed.
- h. It is mandatory that the shoulder harness, where it passes over the shoulders, be 76 mm (3 inch) wide, except as noted below. The shoulder harness straps must be threaded through the three bar adjusters in accordance with manufacturer's instructions.
- i. When the HANS device is used by the driver, FIA certified 51 mm (2 inch) wide shoulder harnesses are allowed. Should a driver, at any time not utilize the HANS device, then 76 mm (3 inch) wide shoulder harnesses are required.

### T5.1.3 Harness Replacement

SFI spec harnesses must be replaced following December 31st of the 2nd year after the date of manufacture as indicated by the label.

FIA spec harnesses must be replaced following December 31st of the expiry year marked on the label.

All Harness must be Manufactured on or after 2010.

(Note: FIA belts are normally certified for five (5) years from the date of manufacture.)

T5.1.4 The restraint system must be worn tightly at all times.

### T5.2 Belt, Strap and Harness Installation - General

T5.2.1 The lap belt, shoulder harness and anti-submarine strap(s) must be securely mounted to the Primary Structure. Such structure and any guide or support for the belts must meet the minimum requirements of T3.4.1.

Note: Rule T3.5.5 applies to these tubes as well so a non-straight shoulder harness bar would require support per T3.5.5

T5.2.2 The tab to which any harness is attached must have:

- a. A minimum cross sectional area of 40 sq. mm (0.062 sq. in) of steel to be sheared or failed in tension at any point of the tab, and
- b. A minimum thickness of 1.6 mm (0.063 inch).
- c. Where lap belts and anti-submarine belts use the same attachment point, a minimum cross sectional area of 90 sq. mm (0.140 sq in) of steel to be sheared if failed in tension at any point of the tab.

Note: Double shear mounting is preferred.

T5.2.3 Harnesses, belts and straps must not pass through a firewall, i.e. all harness attachment points must be on the driver's side of any firewall.

T5.2.4 The attachment of the Driver's Restraint System to a monocoque structure requires an approved Structural Equivalency Spreadsheet per Rule T3.9.

T5.2.5 The restraint system installation is subject to approval of the Chief Technical Inspector.

### T5.3 Lap Belt Mounting

T5.3.1 The lap belt must pass around the pelvic area below the Anterior Superior Iliac Spines (the hip bones).

T5.3.2 The lap belts should not be routed over the sides of the seat. The lap belts should come through the seat at the bottom of the sides of the seat to maximize the wrap of the pelvic surface and continue in a straight line to the anchorage point.

T5.3.3 Where the belts or harness pass through a hole in the seat, the seat must be rolled or grommeted to prevent chafing of the belts.

T5.3.4 To fit drivers of differing statures correctly, in side view, the lap belt must be capable of pivoting freely by using either a shouldered bolt or an eye bolt attachment, i.e. mounting lap belts by wrapping them around frame tubes is no longer acceptable.

T5.3.5 With an "upright driving position", in side view the lap belt must be at an angle of between forty-five degrees (45°) and sixty-five degrees (65°) to the horizontal. This means that the centerline of the lap belt at the seat bottom should be between 0 - 76 mm (0 - 3 inches) forward of the seat back to seat bottom junction. (See Figure 10)

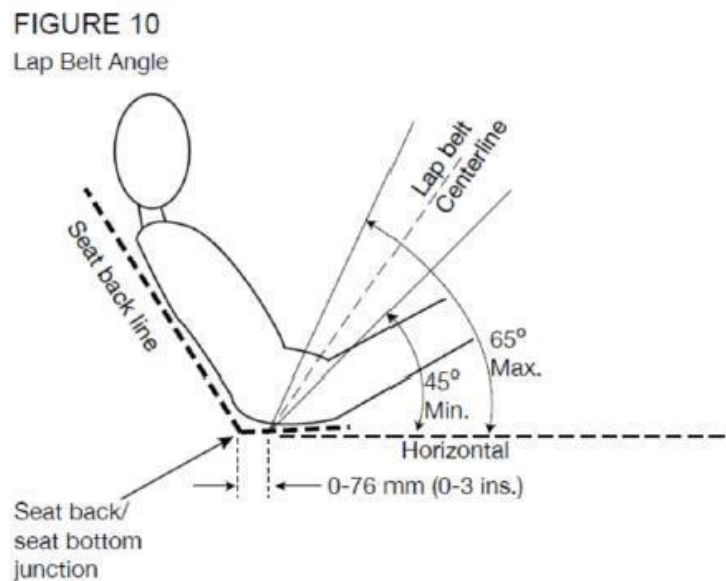

T5.3.6 With a "reclined driving position", in side view the lap belt must be between an angle of sixty degrees (60°) and eighty degrees (80°) to the horizontal.

#### **T5.4 Shoulder Harness**

T5.4.1 The shoulder harness must be mounted behind the driver to structure that meets the requirements of T3.4.1. However, it cannot be mounted to the Main Roll Hoop Bracing or attendant structure without additional bracing to prevent loads being transferred into the Main Hoop Bracing.

T5.4.2 If the harness is mounted to a tube that is not straight, the joints between this tube and the structure to which it is mounted must be reinforced in side view by gussets or triangulation tubes to prevent torsional rotation of the harness mounting tube.

T5.4.3 The shoulder harness mounting points must be between 178 mm (7 inches) and 229 mm (9 inches) apart. (See Figure 11)

FIGURE 11  
 Shoulder Harness Mounting Points

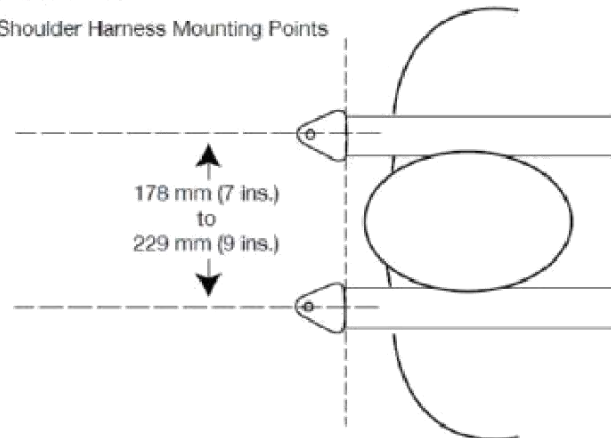

T5.4.4 From the driver's shoulders rearwards to the mounting point or structural guide, the shoulder harness must be between ten degrees (10°) above the horizontal and twenty degrees (20°) below the horizontal. (See Figure 12).

FIGURE 12  
 Shoulder Harness Angle

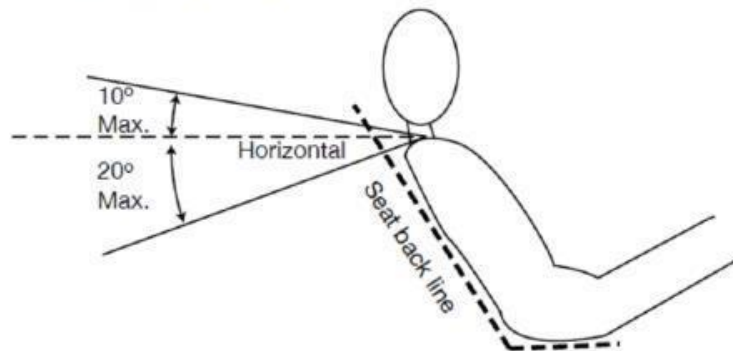

## T5.5 Anti-Submarine Belt Mounting

T5.5.1 The anti-submarine belt of a 5 point harness should be mounted in line with, or angled slightly forward (up to twenty degrees (20°)) of, the driver's chest-groin line.

T5.5.2 The anti-submarine belts of a 6 point harness should be mounted either:

- a. With the belts going vertically down from the groin, or angled up to twenty degrees (20°) rearwards. The anchorage points should be approximately 100 mm (4 inches) apart. Or
- b. With the anchorage points on the Primary Structure at or near the lap belt anchorages, the driver sitting on the anti-submarine belts, and the belts coming up around the groin to the release buckle.

## **T5.6 Head Restraint**

T5.6.1 A head restraint must be provided on the car to limit the rearward motion of the driver's head.

T5.6.2 The restraint must:

- Be vertical or near vertical in side view.
- Be padded with an energy absorbing material (eg:-Ethafoam® or Ensolite®) with a minimum thickness of 38 mm (1.5 inches).
- *Have a minimum width of 15 cms (6 ins).*
- *Have a minimum area of 325 sq. cms (36 sq. ins) AND have a minimum height adjustment of 17.5 cms (7 inches), OR have a minimum height of 28 cms (11 inches).*
- Be located so that for each driver:
  - *The restraint is no more than 25 mm (1 inch) away from the back of the driver's helmet, with the driver in their normal driving position.*
  - *The contact point of the back of the driver's helmet on the head restraint is no less than 50 mm (2 inch) from any edge of the head restraint.*

Note: (1): Head restraints may be changed to accommodate different drivers (See T1.2.2).

*Note: (2): The above requirements must be met for all drivers.*

*Note: (3): Approximately 100mm (4") longitudinal adjustment is required to accommodate 5th to 95th Percentile drivers. This is not a specific rules requirement, but teams must have sufficient longitudinal adjustment and/or alternative thickness head restraints available, such that the above requirements are met by all their drivers.*

T5.6.3 The restraint, its attachment and mounting must be strong enough to withstand a force of 890 Newtons (200 lbs. force) applied in a rearward direction.

## **T5.7 Roll Bar Padding**

Any portion of the roll bar, roll bar bracing or frame which might be contacted by the driver's helmet must be covered with a minimum thickness of 12 mm (0.5 inch) of padding which meets SFI spec 45.1 or FIA 8857-2001.

## **T5.8 Driver's Leg Protection**

T5.8.1 To keep the driver's legs away from moving or sharp components, all moving suspension and steering components, and other sharp edges inside the cockpit between the front roll hoop and a vertical plane 100 mm (4 inches) rearward of the pedals, must be shielded with a shield made of a solid material. Moving components include, but are not limited to

springs, shock absorbers, rocker arms, anti-roll/sway bars, steering racks and steering column CV joints.

T5.8.2 Covers over suspension and steering components must be removable to allow inspection of the mounting points.

## **ARTICLE 6: GENERAL CHASSIS RULES**

### **T6.1 Suspension**

T6.1.1 The car must be equipped with a fully operational suspension system with shock absorbers, front and rear, with usable wheel travel of at least 50.8 mm (2 inches), 25.4 mm (1 inch) jounce and 25.4 mm (1 inch) rebound, with driver seated. The judges reserve the right to disqualify cars which do not represent a serious attempt at an operational suspension system or which demonstrate handling inappropriate for an autocross circuit.

T6.1.2 All suspension mounting points must be visible at Technical Inspection, either by direct view or by removing any covers.

### **T6.2 Ground Clearance**

Ground clearance must be sufficient to prevent any portion of the car, other than the tires, from touching the ground during track events. Intentional or excessive ground contact of any portion of the car other than the tires will forfeit a run or an entire dynamic event.

**Comment:** The intention of this rule is that sliding skirts or other devices that by design, fabrication or as a consequence of moving, contact the track surface are prohibited and any unintended contact with the ground which either causes damage, or in the opinion of the 'dynamic event organizers' could result in damage to the track, will result in forfeit of a run or an entire dynamic event

### **T6.3 Wheels**

T6.3.1 The wheels of the car must be 203.2 mm (8.0 inches) or more in diameter.

T6.3.2 Any wheel mounting system that uses a single retaining nut must incorporate a device to retain the nut and the wheel in the event that the nut loosens. A second nut ("jam nut") does not meet these requirements.

T6.3.3 Standard wheel lug bolts are considered engineering fasteners and any modification will be subject to extra scrutiny during technical inspection. Teams using modified lug bolts or custom designs will be required to provide proof that good engineering practices have been followed in their design.

T6.3.4 Aluminum wheel nuts may be used, but they must be hard anodized and in pristine condition.

## T6.4 Tires

T6.4.1 Vehicles may have two types of tires as follows:

- Dry Tires - The tires on the vehicle when it is presented for technical inspection are defined as its "Dry Tires". The dry tires may be any size or type. They must be treaded for Student Formula Event.
- Rain Tires - Rain tires may be any size or type of treaded or grooved tire provided:
  1. The tread pattern or grooves were molded in by the tire manufacturer.
  2. There is a minimum tread depth of 2.4 mms (3/32 inch).

**Note:** Hand cutting, grooving or modification of the tires by the teams is specifically prohibited.

T6.4.2 Within each tire set, the tire compound or size, or wheel type or size may not be changed after static judging has begun. Tire warmers are not allowed. No traction enhancers may be applied to the tires after the static judging has begun.

## T6.5 Steering

T6.5.1 The steering wheel must be mechanically connected to the wheels, i.e. "steer-by-wire" is prohibited or *electrically actuated steering, is prohibited.*

T6.5.2 The steering system must have positive steering stops that prevent the steering linkages from locking up (the inversion of a four-bar linkage at one of the pivots). The stops may be placed on the uprights or on the rack and must prevent the tires from contacting suspension, body, or frame members during the track events.

T6.5.3 Allowable steering system free play is limited to seven degrees (7°) total measured at the steering wheel.

T6.5.4 The steering wheel must be attached to the column with a quick disconnect. The driver must be able to operate the quick disconnect while in the normal driving position with gloves on.

T6.5.5 The steering wheel must have a continuous perimeter that is near circular or near oval, i.e. the outer perimeter profile can have some straight sections, but no concave sections. "H", "Figure 8", or cutout wheels are not allowed.

T6.5.6 In any angular position, the top of the steering wheel must be no higher than the top-most surface of the Front Hoop. See Figure 3.

T6.5.7 steering systems using cables for actuation are not prohibited by T6.5.1 but additional documentation must be submitted. The team must submit a failure modes and effects analysis report with design details of the proposed system as part of the structural equivalency spreadsheet (SES). The report must outline the analysis that was done to show the steering system will function properly, potential failure modes and the effects of each



failure mode and finally failure mitigation strategies used by the team. The organizing committee will review the submission and advise the team if the design is approved. If not approved, a non-cable based steering system must be used instead.

## T6.6 Jacking Point

T6.6.1 A jacking point, which is capable of supporting the car's weight and of engaging the organizers' "quick jacks", must be provided at the rear of the car.

T6.6.2 The jacking point is required to be:

- Visible to a person standing 1 meter (3 feet) behind the car.
- Painted Bright orange.
- Oriented horizontally and perpendicular to the centerline of the car
- Made from round, 25 - 29 mm (1 - 1 1/8 inch) O.D. aluminum or steel tube
- A minimum of 300 mm (12 inches) long
- Exposed around the lower 180 degrees (180°) of its circumference over a minimum length of 280 mm (11 in)
- The height of the tube is required to be such that:
  - There is a minimum of 75 mm (3 in) clearance from the bottom of the tube to the ground measured at tech inspection.
  - With the bottom of the tube 200 mm (7.9 in) above ground, the wheels do not touch the ground when they are in full rebound.
- Access from the rear of the tube must be unobstructed for at least 300mm of its length

**Comment on Disabled Cars** - The organizers and the Rules Committee remind teams that cars disabled on course must be removed as quickly as possible. A variety of tools may be used to move disabled cars including quick jacks, dollies of different types, tow ropes and occasionally even boards. We expect cars to be strong enough to be easily moved without damage. Speed is important in clearing the course and although the course crew exercises due care, parts of a vehicle can be damaged during removal. The organizers are not responsible for damage that occurs when moving disabled vehicles. Removal/recovery workers will jack, lift, carry or tow the car at whatever points they find easiest to access. Accordingly, we advise teams to consider the strength, location and Identify all obvious jacking, lifting and towing points during the design process.

## T6.7 Rollover Stability

T6.7.1 The track and center of gravity of the car must combine to provide adequate rollover stability.

T6.7.2 Rollover stability will be evaluated on a tilt table using a pass/fail test. The vehicle must not roll when tilted at an angle of sixty degrees (60°) to the horizontal in either direction, corresponding to 1.7 G's. The tilt test will be conducted with the tallest driver in the normal driving position.

---

## **ARTICLE 7: BRAKE SYSTEM**

### **T7.1 Brake System - General**

The car must be equipped with a braking system that acts on all four wheels and is operated by a single control.

T7.1.1 It must have two (2) independent hydraulic circuits such that in the case of a leak or failure at any point in the system, effective braking power is maintained on at least two (2) wheels. Each hydraulic circuit must have its own fluid reserve, either by the use of separate reservoirs or by the use of a dammed, OEM-style reservoir.

T7.1.2 A single brake acting on a limited-slip differential is acceptable.

T7.1.3 The brake system must be capable of locking all four (4) wheels during the test specified below.

T7.1.4 "Brake-by-wire" systems are prohibited.

T7.1.5 Unarmored plastic brake lines are prohibited.

T7.1.6 The braking systems must be protected with scatter shields from failure of the drive train (see T8.4) or from minor collisions.

T7.1.7 In side view no portion of the brake system that is mounted on the sprung part of the car can project below the lower surface of the frame or the monocoque, whichever is applicable.

T7.1.8 The brake pedal shall be designed to withstand a force of 2000 N without any failure of the brake system or pedal box. This may be tested by pressing the pedal with the maximum force that can be exerted by any official when seated normally.

T7.1.9 The brake pedal must be fabricated from steel or aluminum or machined from steel, aluminum or titanium.

### **T7.2 Brake Test**

T7.2.1 The brake system will be dynamically tested and must demonstrate the capability of locking all four (4) wheels and stopping the vehicle in a straight line at the end of an acceleration run at a minimum speed of 40KMPH as specified by the brake inspectors.

### **T7.3 Brake Over-Travel Switch**

T7.3.1 A brake pedal over-travel switch must be installed on the car as part of the shutdown system and wired in series with the shutdown buttons. This switch must be installed so that in the event of brake system failure such that the brake pedal over travels it will result in the shutdown system being activated and controlling the systems as defined in Part IC Article 4 (IC vehicles)

T7.3.2 Repeated actuation of the switch must not restore power to these components, and it must be designed so that the driver cannot reset it.

T7.3.3 The switch must be implemented with analog components, and not through recourse to programmable logic controllers, engine control units, or similar functioning digital controllers.

T7.3.4 The Brake Over-Travel switch must be a mechanical single pole, single throw (commonly known as a two-position) switch (push-pull or flip type) as shown below.



#### **T7.4 Brake Light**

T7.4.1 The car must be equipped with a red brake light. The brake light itself has to have a black background and a rectangular, triangular or near round shape with a minimum shining surface of at least 15cm<sup>2</sup>. Each brake light must be clearly visible from the rear in very bright sunlight.

T7.4.2 This light must be mounted between the wheel centerline and driver's shoulder level vertically and approximately on vehicle centerline laterally.

### **ARTICLE 8: POWERTRAIN**

#### **T8.1 Coolant Fluid Limitations**

Water-cooled engines must only use plain water as the coolant. Glycol-based antifreeze, "water wetter", water pump lubricants of any kind, or any other additives are strictly prohibited.

#### **T8.2 System Sealing**

T8.2.1 Any cooling or lubrication system must be sealed to prevent leakage.

T8.2.2 Separate catch cans must be employed to retain fluids from any vents for the coolant system or lubrication system. Each catch-can must have a minimum volume of ten (10) percent of the fluid being contained or 0.9 liter (one U.S. quart) whichever is greater.

T8.2.3 Catch cans must be capable of containing boiling water without deformation, and be located rearwards of the firewall below driver's shoulder level, and be positively retained, i.e. no tie-wraps or tape.

T8.2.4 Any catch can on the cooling system must vent through a hose with a minimum internal diameter of 3 mm (1/8 inch) down to the bottom levels of the Frame.

### **T8.3 Transmission and Drive**

Any transmission and drivetrain may be used.

### **T8.4 Drive Train Shields and Guards**

T8.4.1 Exposed high-speed final drivetrain equipment such as Continuously Variable Transmissions (CVTs), sprockets, gears, pulleys, torque converters, clutches, belt drives, clutch drives and electric motors, must be fitted with scatter shields in case of failure. The final drivetrain shield must cover the chain or belt from the drive sprocket to the driven sprocket/chain wheel/belt or pulley. The final drivetrain shield must start *and end* parallel to the lowest point of the chain wheel/belt/pulley. (See figure below) Body panels or other existing covers are not acceptable unless constructed from approved materials per T8.4.3 or T8.4.4.

*Note: If equipped, the engine drive sprocket cover may be used as part of the scatter shield system.*

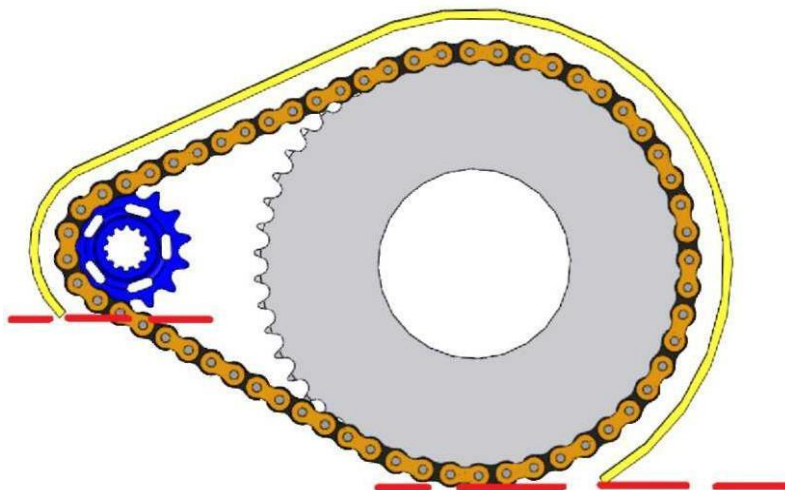

Comment: Scatter shields are intended to contain drivetrain parts which might separate from the car.

T8.4.2 Perforated material may not be used for the construction of scatter shields.

T8.4.3 Chain Drive - Scatter shields for chains must be made of at least 2.66 mm (0.105 inch) steel (no alternatives are allowed), and have a minimum width equal to three (3) times the width of the chain. The guard must be centered on the center line of the chain and remain aligned with the chain under all conditions.

T8.4.4 Non-metallic Belt Drive - Scatter shields for belts must be made from at least 3.0 mm (0.120 inch) Aluminum Alloy 6061-T6, and have a minimum width that is equal to 1.7 times the width of the belt. The guard must be centered on the center line of the belt and remain aligned with the belt under all conditions.

T8.4.5 Attachment Fasteners - All fasteners attaching scatter shields and guards must be a minimum 6mm Metric Grade 8.8 (1/4 inch SAE Grade 5) or stronger.

T8.4.6 Finger Guards - Finger guards are required to cover any drivetrain parts that spin while the car is stationary with the engine running. Finger guards may be made of lighter material, sufficient to resist finger forces. Mesh or perforated material may be used but must prevent the passage of a 12 mm (1/2 inch) diameter object through the guard.

**Comment:** Finger guards are intended to prevent finger intrusion into rotating equipment while the vehicle is at rest.

## **T8.5 Integrity of systems carrying fluids - Tilt Test**

### **T8.5.1 Tilt Test - Fluids**

During technical inspection, the car must be capable of being tilted to a forty-five degree (45°) angle without leaking fluid of any type.

T8.5.2 The tilt test will be conducted with the vehicle containing the maximum amount of fluids it will carry during any test or event.

## **ARTICLE 9: AERODYNAMIC DEVICES**

### **T9.1 Aero Dynamics and Ground Effects - General**

All aerodynamic devices must satisfy the following requirements:

### **T9.2 Location**

T9.2.1 In plain view, no part of any aerodynamic device, wing, under tray or splitter can be:

- a. Further forward than 762 mm (30 inches) forward of the fronts of the front tires
- b. No further rearward than 305 mm (12 inches) rearward of the rear of the rear tires.
- c. No wider than the outside of the front tires or rear tires measured at the height of the hubs, whichever is wider.

### **T9.3 Minimum Radii of Edges of Aerodynamic Devices**

T9.3.1 All wing edges including wings, end plates, Gurney flaps, wicker bills and undertrays that could contact a pedestrian must have a minimum radius of 1.5 mm (0.060 inch).

### **T9.4 Ground Effect Devices**

No power device may be used to move or remove air from under the vehicle except fans designed exclusively for cooling. Power ground effects are prohibited.

## **T9.5 Driver Egress Requirements**

T9.5.1 Egress from the vehicle within the time set in Rule T4.8 "Driver Egress," must not require any movement of the wing or wings or their mountings.

T9.5.2 The wing or wings must be mounted in such positions, and sturdily enough, that any accident is unlikely to deform the wings or their mountings in such a way to block the driver's egress.

## **ARTICLE 10: COMPRESSED GAS SYSTEMS AND HIGH PRESSURE HYDRAULICS**

### **T10.1 Compressed Gas Cylinders and Lines**

Any system on the vehicle that uses a compressed gas as an actuating medium must comply with the following requirements:

- a. Working Gas-The working gas must be nonflammable, e.g. air, nitrogen, carbon dioxide.
- b. Cylinder Certification- The gas cylinder/tank must be of proprietary manufacture, designed and built for the pressure being used, certified by an accredited testing laboratory in the country of its origin, and labeled or stamped appropriately.
- c. Pressure Regulation-The pressure regulator must be mounted directly onto the gas cylinder/tank.
- d. Protection - The gas cylinder/tank and lines must be protected from rollover, collision from any direction, or damage resulting from the failure of rotating equipment.
- e. Cylinder Location- The gas cylinder/tank and the pressure regulator must be located either rearward of the Main Roll Hoop and within the envelope defined by the Main Roll Hoop and the Frame (see T3.3), or in a structural side-pod. In either case it must be protected by structure that meets the requirements of T3.25 or T3.34. It must not be located in the cockpit.
- f. Cylinder Mounting- The gas cylinder/tank must be securely mounted to the Frame, engine or transmission.
- g. Cylinder Axis- The axis of the gas cylinder/tank must not point at the driver.
- h. Insulation- The gas cylinder/tank must be insulated from any heat sources, e.g. the exhaust system.
- i. Lines and Fittings- The gas lines and fittings must be appropriate for the maximum possible operating pressure of the system.

### **T10.2 High Pressure Hydraulic Pumps and Lines**

The driver and anyone standing outside the car must be shielded from any hydraulic pumps and lines with line pressures of 2100 kPa (300 psi) or higher. The shields must be steel or aluminum with a minimum thickness of 1 mm (0.039 inch).

Note: Brake lines are not classified as "hydraulic pump lines" and as such brake lines are excluded from T10.2.

## **ARTICLE 11: FASTENERS**

### **T11.1 Fastener Grade Requirements**

T11.1.1 All threaded fasteners utilized in the driver's cell structure, and the steering, braking, driver's harness and suspension systems must meet or exceed, SAE Grade 5, Metric Grade 8.8 and/or AN/MS specifications.

T11.1.2 The use of button head cap, pan head, flat head or round head screws or bolts in critical locations is prohibited. These locations include the driver's cell structure, and driver's harness attachment.

Note: Hexagonal recessed drive screws or bolts (sometimes called Socket head cap screws or Allen screws/bolts) are permitted.

### **T11.2 Securing Fasteners**

T11.2.1 All critical bolt, nuts, and other fasteners on the steering, braking, driver's harness, and suspension must be secured from unintentional loosening by the use of positive locking mechanisms. Positive locking mechanisms include:

- Correctly installed safety wiring
- Cotter pins
- Nylon lock nuts
- Prevailing torque lock nuts

**Note:** Lock washers and thread locking compounds, e.g. Loctite®, DO NOT meet the positive locking requirement.

T11.2.2 There must be a minimum of two (2) full threads projecting from any lock nut.

T11.2.3 All spherical rod ends and spherical bearings on the steering or suspension must be in double shear or captured by having a screw/bolt head or washer with an O.D. that is larger than spherical bearing housing I.D.

T11.2.4 Adjustable tie-rod ends must be constrained with a jam nut to prevent loosening.

## **ARTICLE 12: TRANSPONDERS**

### **T12.1 Transponders – SUPRA SAEINDIA Competition**

T12.1.1 Transponders will be used as part of the timing system for the dynamic events at the SUPRA SAEINDIA competitions which will be provided by the organizer SAEINDIA.



### T12.3 Transponder Mounting - All Events

The transponder mounting requirements are:

- a. Orientation - The transponder must be mounted vertically and orientated so the number can be read "right-side up".
- b. Location - The transponder must be mounted on the driver's right side of the car forward of the front roll hoop. The transponder must be no more than 60 cm (24 in) above the track.
- c. Obstructions - There must be an open, unobstructed line between the antenna on the bottom of the transponder and the ground. Metal and carbon fiber may interrupt the transponder signal. The signal will normally transmit through fiberglass and plastic. If the signal will be obstructed by metal or carbon fiber, a 10.2 cm (4 in) diameter opening can be cut, the transponder mounted flush with the opening, and the opening covered with a material transparent to the signal.
- d. Protection - Mount the transponder where it will be protected from obstacles.

## ARTICLE 13: VEHICLE IDENTIFICATION

### T13.1 Car Number

T13.1.1 Each car will be assigned a number at the time of its entry into a competition.

T13.1.2 Car numbers must appear on the vehicle as follows:

Locations: In three (3) locations: the **front** and both **sides**;

- a. Height: At least 152.4 mm (6 inch) high;
- b. Font: Block numbers (i.e. sans-serif characters). Italic, outline, serif, shadow, or cursive numbers are prohibited.
- c. Stroke Width and Spacing between Numbers: At least 18 mm (3/4 inch).
- d. Color: Either white numbers on a black background or black numbers on a white background. No other color combinations will be approved.



- e. Background shape: The number background must be one of the following: round, oval, square or rectangular. There must be at least 25.4 mm (1 inch) between the edge of the numbers and the edge of the background.
- f. Clear: The numbers must not be obscured by parts of the car, e.g. wheels, side pods, exhaust system, etc.

T13.1.3 Car numbers for teams registered for SUPRASAEINDIA competitions can be found on the "Registered Teams" section of the relevant SUPRASAEINDIA website.

**Comment:** Car numbers must be quickly read by course marshals when your car is moving at speed. Make your numbers easy to see and easy to read.

Example:



### T13.2 School Name

T13.2.1 Each car must clearly display the school name (or initials - if unique and generally recognized) in roman characters at least 50 mm (2 inch) high on both sides of the vehicle. The characters must be placed on a high contrast background in an easily visible location.

T13.2.2 The school name may also appear in non-roman characters, but the roman character version must be uppermost on the sides.

### T13.3 SAEINDIA Logo

The SAEINDIA logo must be displayed on the front and/or both sides of the vehicle in a prominent location. SAEINDIA logo stickers will be provided to the teams on site.

### T13.4 Technical Inspection Sticker Space

T13.4.1 Technical inspection stickers will be placed on the upper nose of the vehicle. Cars must have a clear and unobstructed area at least 25.4 cm wide x 20.3 cm high (10" x 8") on the upper front surface of the nose along the vehicle centerline.

**T13.4.2** Vehicles that are being entered into multiple competitions in the SUPRASAEINDIA series must allow sufficient space along the nose centerline for all inspection stickers.

**On Vehicle Publicity**

The following are the mandatory locations for various stickers

- (Logos): A - Number Sticker
- B - Team's Name
- C - Event Sponsor
- D - Team Sponsor
- E - SAEINDIA Logo
- F - OK Sticker (SUPRASAEINDIA Logo)



At the above locations, only the specified stickers can be stuck. At any point of time, the Numbers Sticker has to be prominently visible. After sticking all the above mandatory stickers, if extra space is available, the team can use it as per its choice.



**ARTICLE 14: EQUIPMENT REQUIREMENTS**

**T14.1 Driver's Equipment**

The equipment specified below must be worn by the driver anytime he or she is in the cockpit with the engine running.

**T14.2 Helmet**

A well-fitting, closed face helmet that meets one of the following certifications and is labeled as such:

Example:



- Snell K2000, K2005, K2010, M2000, M2005, M2010, SA2000, SA2005, SA2010
- SFI 31.2A, SFI 31.1/2005
- FIA 8860-2004, FIA 8860-2010
- British Standards Institution BS 6658-85 Type A/FR rating (Types B are not accepted).
- EN 22-05.

Open faced helmets are not approved.

All helmets to be used in the competition must be presented during Technical Inspection where approved helmets will be stickered. The organizer reserves the right to impound all non-approved helmets until the end of the competition.

### **T14.3 Balaclava**

A balaclava which covers the driver's head, hair and neck, made from acceptable fire resistant material as defined in T14.12, or a full helmet skirt of acceptable fire resistant material. The balaclava requirement applies to drivers of either gender, with any hair length.

### **T14.4 Eye Protection**

Impact resistant goggles or helmet face shield, made from approved impact resistant materials. The face shield supplied with approved helmets (See T14.2 above) meets this requirement.

### **T14.5 Suit**

A fire resistant one piece suit, made from a minimum of two (2) layers that covers the body from the neck down to the ankles and the wrists. The suit must be certified to one of the following standards and be labeled as such:

- SFI 3-2A/5 (or higher)



- FIA Standard 1986



**NORME 1986/ 1986 STANDARD**

- FIA Standard 8856-2000



#### **T14.6 Underclothing**

It is strongly recommended that all competitors wear fire resistant underwear (long pants and long sleeve t-shirt) under their approved driving suit. This fire resistant underwear should be made from acceptable fire resistant material as listed in T14.12 and should cover the driver's body completely from neck down to ankles and wrists.

Note: If you do not wear fire resistant underwear it is strongly recommended that you wear cotton underwear (t-shirt and long underpants) under your approved driving suit.

#### **T14.7 Socks**

Fire resistant socks made from acceptable fire resistant material as defined in T14.12, below, that cover the bare skin between the driver's suit and the boots or shoes.

#### **T14.8 Shoes**

Fire resistant shoes made from acceptable fire resistant material as defined in T14.12. The shoes must be certified to the standard and labeled as such:

- SFI 3.3
- FIA 8856-2000

#### **T14.9 Gloves**

Fire resistant gloves made from made from acceptable fire resistant material as defined in T14.12. Gloves of all leather construction or fire resistant gloves constructed using leather palms with no insulating fire resisting material underneath are not acceptable.

#### **T14.10 Arm Restraints**

Arm restraints are required and must be worn such that the driver can release them and exit the vehicle unassisted regardless of the vehicle's position. Arm restraints must be commercially manufactured. Note: Arm restraints certified to SFI Standard 3.3 and labeled as such meet this requirement.

#### **T14.11 Driver's Equipment Condition**

All driving apparel covered by ARTICLE 14: must be in good condition. Specifically, driving apparel must not have any tears, rips, open seams, areas of significant wear or abrasion or stains which might compromise fire resistant performance.

#### **T14.12 Fire Resistant Material**

For the purpose of this section some, but not all, of the approved fire resistant materials are: Carbon X, Indura, Nomex, Polybenzimidazole (commonly known as PBI) and Proban.

#### **T14.13 Synthetic Material – Prohibited**

T-shirts, socks or other undergarments (not to be confused with FR underwear) made from nylon or any other synthetic material which will melt when exposed to high heat are prohibited.

#### T14.14 Fire Extinguishers

Each team must have at least two (2) 0.9 kg (2 lb.) dry chemical/dry powder.

T14.14.1 The following are the minimum ratings, any of which are acceptable at any STUDENT FORMULA Series event:

- powder or any other extinguishant homologated by the FIA

Extinguishers of larger capacity (higher numerical ratings) are acceptable.

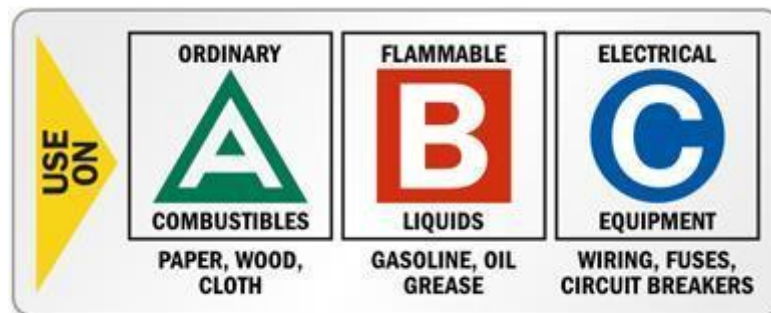

T14.14.2 All extinguishers must be equipped with a manufacturer installed pressure/charge gauge.

T14.14.3 Except for the initial inspection, one extinguisher must readily be available in the team's paddock area, and the second must accompany the vehicle wherever the vehicle is moved. Both extinguishers must be presented with the vehicle at Technical Inspection.

T14.14.4 As a team option, commercially available on-board fire systems are encouraged as an alternative to the extinguisher that accompanies the vehicle.

T14.14.5 Hand held fire extinguishers are **not** permitted to be mounted on or in the car.

T14.14.6 **On-board fire-extinguishers are not required but if used must be of AFFF type, no drychemical extinguishers allowed as an on board extinguisher.**

**Note: Halon extinguishers and systems are prohibited.**

**Note: AFFF extinguishers are permitted.**

## ARTICLE 15: POSSIBLE FUTURE RULES CHANGES

### Notice of Possible Rule Changes for the 2018 STUDENT FORMULA Series

This section is intended to provide teams with advance notice of possible changes to the STUDENT FORMULA Rules that are being considered by the STUDENT FORMULA Rules Committee. Only changes that might have a significant influence on a team's design, manufacturing or operating decisions are listed.

The changes presented in this section are only possibilities and may not be implemented. This section is provided as information and is not intended to be the final text of the rules under consideration.

**Restriction on Team Membership** - The Committee is considering limiting the students who present to judges or drive during the competition to students registered at the university that registers the team.

**5th Percentile Female Mannequin** - The committee is considering the introduction of 5<sup>th</sup> percentile mannequin to confirm that the driver cell will fit both a 95<sup>th</sup> percentile male and a 5<sup>th</sup> percentile female driver.

**Drive by Wire Throttle** - The Committee is considering that drive by wire throttles can be used on STUDENT FORMULA cars if they include the brake panic switch. Feedback on this topic and whether you would like to adopt a throttle by wire throttle would be appreciated.

**Noise Test** - To improve the sound quality of single cylinder engines for track workers the sound measuring units may be changed to dBC. This is more consistent with human hearing at the higher volumes called out in the rules. Cheap, commercially available sound meters are generally able to display dBC.



---

**APPENDIX T-1**

**STRUCTURAL EQUIVALENCY SPREADSHEET**

**APPENDIX T-2**

**IMPACT ATTENUATOR DATA REPORT**

Appendix T-1 & T-2 is posted at [www.suprasaeindia.org](http://www.suprasaeindia.org)

---

**2018 STUDENT FORMULA RULES**

**PART IC - INTERNAL COMBUSTION ENGINE VEHICLES**

**ARTICLE 1: INTERNAL COMBUSTION ENGINE POWERTRAINS**

**IC1.1 Engine Limitation**

IC1.1.1 The engine(s) used to power the car must be a piston engine(s) using a four-stroke primary heat cycle with a displacement not exceeding 610 cc per cycle. Hybrid powertrains, such as those using electric motors running off stored energy, are prohibited.

Note: All waste/rejected heat from the primary heat cycle may be used. The method of conversion is not limited to the four-stroke cycle.

IC1.1.2 The engine can be modified within the restrictions of the rules.

IC1.1.3 If more than one engine is used, the total displacement cannot exceed 610 cc and the air for all engines must pass through a single air intake restrictor (see IC1.6 "Intake System Restrictor.")

**IC1.2 Engine Inspection**

The organizer will measure or tear down a substantial number of engines to confirm conformance to the rules. The initial measurement will be made externally with a measurement accuracy of one (1) percent. When installed to and coaxially with spark plug hole, the measurement tool has dimensions of 381 mm (15 inches) long and 30 mm (1.2 inches) diameter. Teams may choose to design in access space for this tool above each spark plug hole to reduce time should their vehicle be inspected. Teams will have to produce the proper invoice of the Engine with Engine specification during the technical inspection at main event.

**IC1.3 Starter**

Each car must be equipped with an on-board starter which, during the competition, must be used to start the car at all times. Push starts, or the use of a remote starter, are prohibited.

**IC1.4 Air Intake System**

**IC1.4.1 Air Intake System Location**

All parts of the engine air and fuel control systems (including the throttle or carburetor, and the complete air intake system, including the air cleaner and any air boxes) must lie within the surface defined by the top of the roll bar and the outside edge of the four tires. (See Figure 13).



**REAR VIEW SURFACE ENVELOPE**

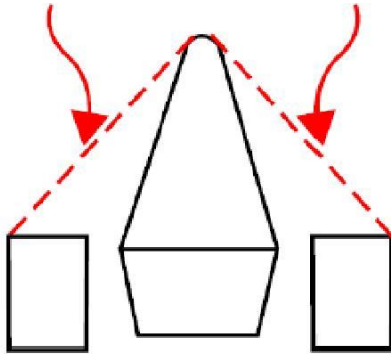

**SIDE VIEW SURFACE ENVELOPE**

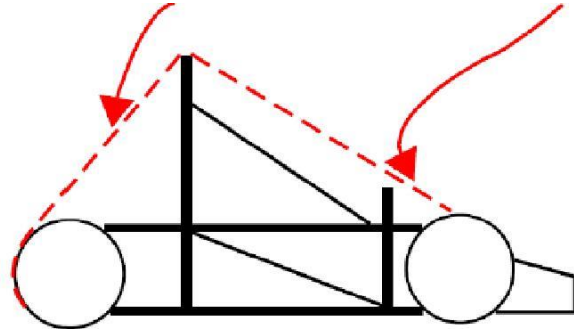

**Figure 13**

IC1.4.2 Any portion of the air intake system that is less than 350 mm (13.8 inches) above the ground must be shielded from side or rear impact collisions by structure built to Rule T3.25 or T3.34 as applicable.

IC1.4.3 Intake Manifold - The intake manifold must be securely attached to the engine block or cylinder head with brackets and mechanical fasteners. This precludes the use of hose clamps, plastic ties, or safety wires. The use of rubber bushings or hose is acceptable for creating and sealing air passages, but is not considered a structural attachment.

IC1.4.4 Intake systems with significant mass or cantilever from the cylinder head must be supported to prevent stress to the intake system. Supports to the engine must be rigid. Supports to the frame or chassis must incorporate some isolation to allow for engine movement and chassis flex.

### **IC1.5 Throttle and Throttle Actuation**

#### **IC1.5.1 Carburetor/Throttle Body**

The car must be equipped with a carburetor or throttle body. The carburetor or throttle body may be of any size or design.

#### **IC1.5.2 Throttle Actuation**

The throttle must be actuated mechanically, i.e. via a cable or a rod system. The use of electronic throttle control (ETC) or "throttle-by-wire" is prohibited.

IC1.5.3 The throttle cable or rod must have smooth operation, and must not have the possibility of binding or sticking.

IC1.5.4 The throttle actuation system must use at least two (2) return springs located at the throttle body, so that the failure of any component of the throttle system will not prevent the throttle returning to the closed position.

**Note:** Throttle Position Sensors (TPS) are NOT acceptable as return springs.

IC1.5.5 Throttle cables must be at least 50.8 mm (2 inches) from any exhaust system component and out of the exhaust stream.

IC1.5.6 A positive pedal stop must be incorporated on the throttle pedal to prevent over stressing the throttle cable or actuation system.

IC1.5.7 The throttle pedal cable must be protected from being bent or kinked by the driver's foot when it is operated by the driver or when the driver enters or exits the vehicle.

IC1.5.8 If the throttle system contains any mechanism that could become jammed, for example a gear mechanism, then this must be covered to prevent ingress of any debris.

**IC1.6 Intake System Restrictor**

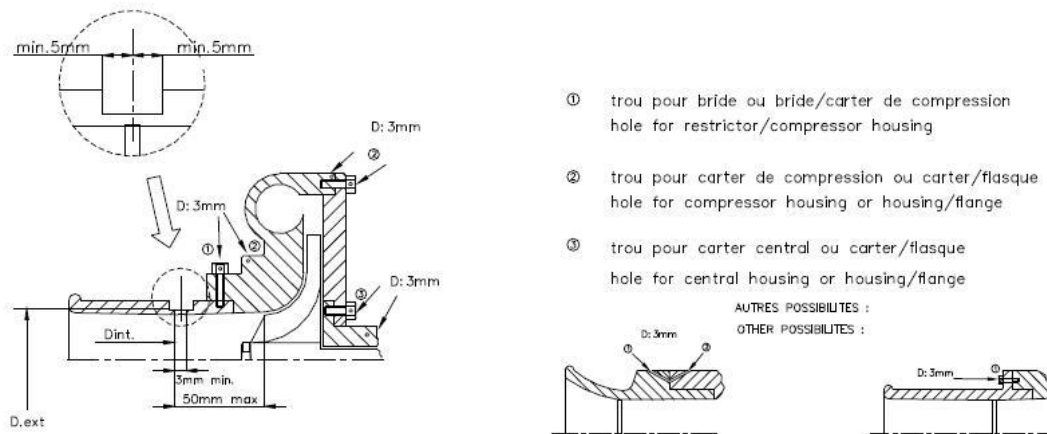

254-4

In order to limit the power capability from the engine, a single circular restrictor must be placed in the intake system between the throttle and the engine and all engine airflow must pass through the restrictor.

Sequence is as below:

Throttle – Restrictor – Engine Intake

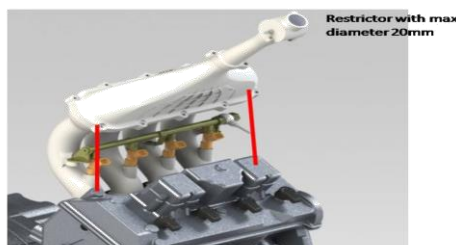

IC1.6.2 Any device that has the ability to throttle the engine downstream of the restrictor is prohibited.

IC1.6.3 The maximum restrictor diameters are:

- Gasoline fueled cars - 20.0 mm (0.7874 inch)

IC1.6.4 The restrictor must be located to facilitate measurement during the inspection process.

IC1.6.5 The circular restricting cross section may NOT be movable or flexible in any way, e.g. the restrictor may not be part of the movable portion of a barrel throttle body.

IC1.6.6 If more than one engine is used, the intake air for all engines must pass through the one restrictor.

### **IC1.7 Turbochargers & Superchargers**

IC1.7.1 Turbochargers or superchargers are allowed if the competition team designs the application. Engines that have been designed for and originally come equipped with a turbocharger are not allowed to compete with the turbo installed.

IC1.7.2 Teams using turbocharger or supercharger should have following sequence:  
Restrictor - Compressor – Throttle – Engine Intake

IC1.7.3 The intake air may be cooled with an intercooler (a charge air cooler). Only ambient air may be used to remove heat from the intercooler system. Air-to-air and water-to-air intercoolers are permitted. The coolant of a water-to-air intercooler system must comply with Rule T8.1.

### **IC1.8 Fuel Lines**

IC1.8.1 Plastic fuel lines between the fuel tank and the engine (supply and return) are prohibited and **Metallic Fuel Filter should Only be Used**

IC1.8.2 If rubber fuel line or hose is used, the components over which the hose is clamped must have annular bulb or barbed fittings to retain the hose. Also, clamps specifically designed for fuel lines must be used. These clamps have three (3) important features, (i) a full 360 degree (360°) wrap, (ii) a nut and bolt system for tightening, and (iii) rolled edges to prevent the clamp cutting into the hose. Worm-gear type hose clamps are not approved for use on any fuel line.

IC1.8.3 Fuel lines must be securely attached to the vehicle and/or engine.

IC1.8.4 All fuel lines must be shielded from possible rotating equipment failure or collision damage.

### **IC1.9 Fuel Injection System Requirements**

The following requirements apply to fuel injection systems.

IC1.9.1 Fuel Lines - Flexible fuel lines must be either (i) metal braided hose with either crimped-on or reusable, threaded fittings, or (ii) reinforced rubber hose with some form of abrasion resistant protection with fuel line clamps per IC1.8.2. Note: Hose clamps over metal braided hose will not be accepted.

IC1.9.2 Fuel Rail - The fuel rail must be securely attached to the engine cylinder block, cylinder head, or intake manifold with brackets and mechanical fasteners. This precludes the use of hose clamps, plastic ties, or safety wire.

### **IC1.10 Crankcase / engine lubrication venting**

IC1.10.1 Any crankcase or engine lubrication vent lines routed to the intake system must be connected upstream of the intake system restrictor.

IC1.10.2 Crankcase breathers that pass through the oil catch tank(s) to exhaust systems, or vacuum devices that connect directly to the exhaust system, are prohibited.

## **ARTICLE 2: FUEL AND FUEL SYSTEM**

### **IC2.1 Fuel**

The basic fuel available at competitions in the STUDENT FORMULA Series is unleaded gasoline. For the SUPRASAEINDIA competitions this should have an octane rating of ( 91 RON) minimum and for other competitions, the unleaded gasoline that will be available will be published by the relevant organizing committee. However, the basic fuel may be changed at the discretion of the organizing body. Other fuels may be available at the discretion of the organizing body.

IC2.1.1 Unless otherwise announced by the individual organizing body, the fuel at competitions in the STUDENT FORMULA Series will be provided by the organizer.

IC2.1.2 During all performance events the cars must be operated with the fuels provided by the organizer at the competition.

IC2.1.3 Nothing may be added to the provided fuels. This prohibition includes nitrous oxide or any other oxidizing agent.

Consult the individual competition websites for fuel types and other information.

### **IC2.2 Fuel Additives - Prohibited**

IC2.2.1 No agents other than fuel (gasoline ), and air may be induced into the combustion chamber. Non-adherence to this rule will be reason for disqualification.

IC2.2.2 Officials have the right to inspect the oil.

### **IC2.3 Fuel Temperature Changes - Prohibited**

The temperature of fuel introduced into the fuel system may not be changed with the intent to improve calculated efficiency.

### **IC2.4 Fuel Tanks**

IC2.4.1 The fuel tank is defined as that part of the fuel containment device that is in contact with the fuel. It may be made of a rigid material or a flexible material.

IC2.4.2 Fuel tanks made of a rigid material cannot be used to carry structural loads, e.g. from roll hoops, suspension, engine or gearbox mounts, and must be securely attached to the vehicle structure with mountings that allow some flexibility such that chassis flex cannot unintentionally load the fuel tank.

IC2.4.3 Any fuel tank that is made from a flexible material, for example a bladder fuel cell or a bag tank, must be enclosed within a rigid fuel tank container which is securely attached to the vehicle structure. Fuel tank containers (containing a bladder fuel cell or bag tank) may be load carrying.

IC2.4.4 Any size fuel tank may be used.

IC2.4.5 The fuel Tank system must have a provision for emptying / Draining the fuel tank if required.

### **IC2.5 Fuel System Location Requirements**

IC2.5.1 All parts of the fuel storage and supply system must lie within the surface defined by the top of the roll bar and the outside edge of the four tires. (See Figure 13).

IC2.5.2 All fuel tanks must be shielded from side or rear impact collisions. Any fuel tank which is located outside the Side Impact Structure required by T3.25 or T3.34 must be shielded by structure built to T3.3, or T3.34.

IC2.5.3 A firewall must be incorporated to separate the fuel tank from the driver, per Rule T4.5.

### **IC2.6 Fuel Tank Filler Neck & Sight Tube**

IC2.6.1 All fuel tanks must have a filler neck:

- (a) at least 38 mm (1.5 inches) diameter,
- (b) at least 125 mm (4.9 inches) vertical height and
- (c) angled at no more than forty-five degrees (45°) from the vertical.

IC2.6.2 The 125 mm of vertical height must be above the top level of the tank, and must be accompanied by a clear fuel resistant sight tube for reading the fuel level. (Figure 14)

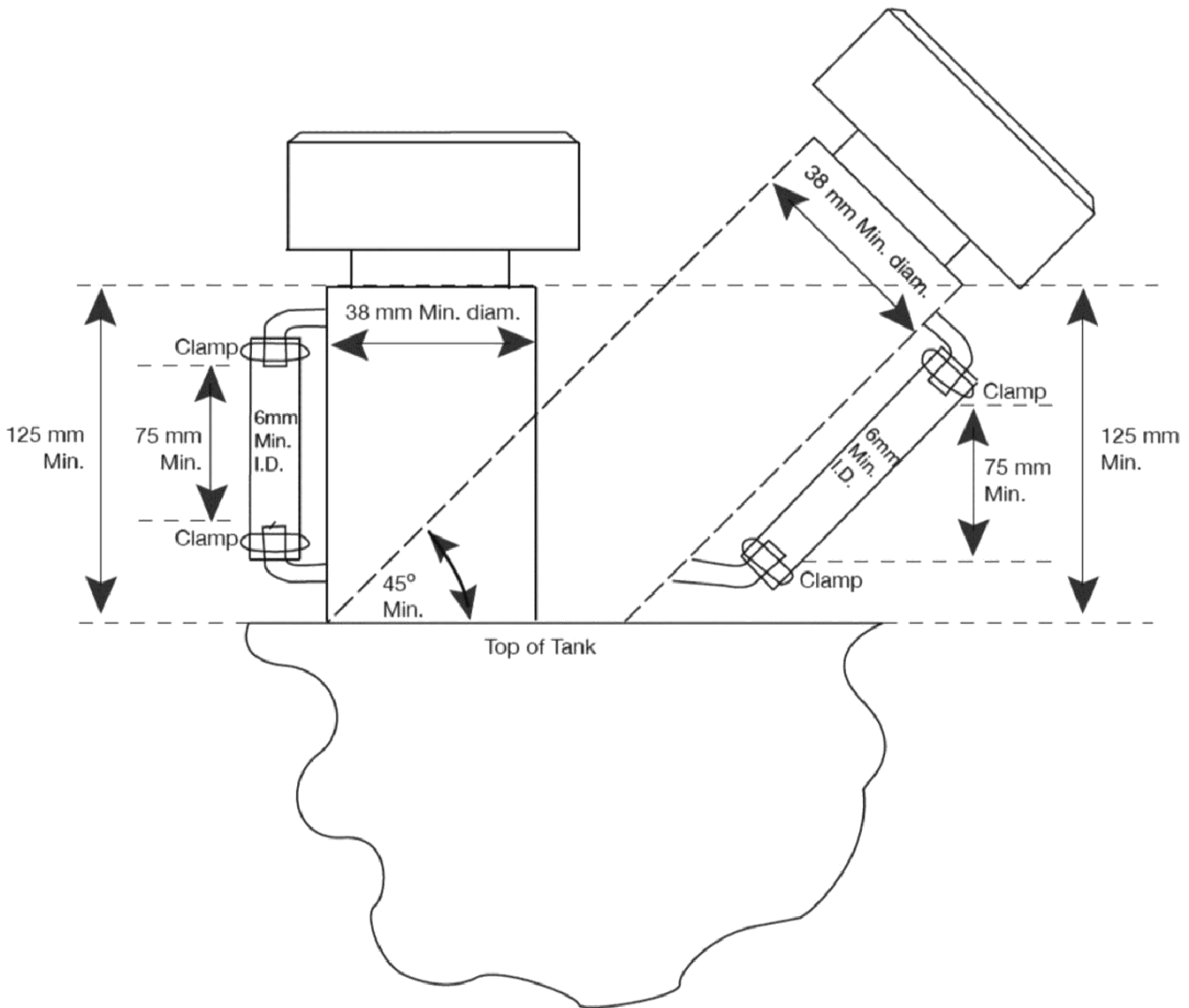

**FIGURE 14**

IC2.6.3 The sight tube must have at least 75 mm (3 inches) of vertical height and a minimum inside diameter of 6 mm (0.25 inches).

IC2.6.4 The sight tube must not run below the top surface of the fuel tank.

IC2.6.5 A clear filler tube may be used as a sight tube, subject to approval by the Rules Committee or technical inspectors at the event.

IC2.6.6 Fuel Level Line - A permanent, non-moveable fuel level line must be located between 12.7 mm and 25.4 mm (0.5 inch and 1 inch) below the top of the sight tube. This line will be used as the fill line for the Tilt Test (Rule T8.5), and before and after the Endurance Test to measure the amount of fuel used during the Endurance Event.

IC2.6.7 The sight tube and fuel level line must be clearly visible to an individual filling the tank.

**IC2.7 Tank Filling Requirement**

IC2.7.1 The fuel tank must be capable of being filled to capacity without manipulating the tank or the vehicle in any manner. During fueling or refueling the vehicle may only be touched by the fuel crew and officials. The tank will be filled to the fill line, or if a filling system is used, to the automatic stop point. If, for any reason, the fuel level changes after the team has moved the vehicle, then no additional fuel will be added.

IC2.7.2 The fuel system must be designed such that the spillage during refueling cannot contact the driver position, exhaust system, hot engine parts, or the ignition system.

IC2.7.3 Belly pans must be vented to prevent accumulation of fuel.

### **IC2.8 Venting Systems**

IC2.8.1 The fuel tank and carburetor venting systems must be designed such that fuel cannot spill during hard cornering or acceleration. This is a concern since motorcycle carburetors normally are not designed for lateral accelerations.

IC2.8.2 All fuel vent lines must be equipped with a check valve to prevent fuel leakage when the tank is inverted. All fuel vent lines must exit outside the bodywork.

## **ARTICLE 3: EXHAUST SYSTEM AND NOISE CONTROL**

### **IC3.1 Exhaust System General**

#### **IC3.1.1 Exhaust Outlet**

The exhaust must be routed so that the driver is not subjected to fumes at any speed considering the draft of the car.

IC3.1.2 The exhaust outlet(s) must not extend more than 45 cm (17.7 inches) behind the centerline of the rear axle, and shall be no more than 60 cm (23.6 inches) above the ground.

IC3.1.3 Any exhaust components (headers, mufflers, etc.) that protrude from the side of the body in front of the main roll hoop must be shielded to prevent contact by persons approaching the car or a driver exiting the car.

### **IC3.2 Noise Measuring Procedure**

IC3.2.1 The sound level will be measured during a static test. Measurements will be made with a free-field microphone placed free from obstructions at the exhaust outlet level, 0.5 m (19.68 inches) from the end of the exhaust outlet, at an angle of forty-five degrees (45°) with the outlet in the horizontal plane. The test will be run with the gearbox in neutral at the engine speed defined below. Where more than one exhaust outlet is present, the test will be repeated for each exhaust and the highest reading will be used.

IC3.2.2 The car must be compliant at all engine speeds up to the test speed defined below.

IC3.2.3 If the exhaust has any form of movable tuning or throttling device or system, it must be compliant with the device or system in all positions. The position of the device must be visible to the officials for the noise test and must be manually operable by the officials during the noise test.

#### IC3.2.4 Test Speeds

The test speed for a given engine will be the engine speed that corresponds to an average piston speed of 914.4 m/min (3,000 ft/min) for automotive or motorcycle engines, and 731.5 m/min (2,400 ft/min) for "industrial engines". The calculated speed will be rounded to the nearest 500 rpm. The test speeds for typical engines will be published by the organizers.

An "industrial engine" is defined as an engine which, according to the manufacturers' specifications and without the required restrictor, is not capable of producing more than 5 hp per 100cc. To have an engine classified as "an industrial engine", approval must be obtained from organizers prior to the Competition.

#### IC3.3 Maximum Sound Level

The maximum permitted sound level is 110 dBC, fast weighting.

#### IC3.4 Noise Level Re-testing

At the option of the officials, noise can be measured at any time during the competition. If a car fails the noise test, it will be withheld from the competition until it has been modified and re-passes the noise test.

### ARTICLE 4: ELECTRICAL SYSTEM AND SHUTDOWN SYSTEM

#### IC4.1 Master Switches

IC4.1.1 The vehicle must be equipped with two (2) master switches which form part of the shutdown system. Actuating either switch must stop the engine.

IC4.1.2 The international electrical symbol consisting of a red spark on a white-edged blue triangle must be affixed in close proximity to each switch.

**Note:** Teams are reminded that any alternator field wire must also be disabled by each master switch to prevent any possible feedback through the field coil circuit.

#### IC4.2 Primary Master Switch

IC4.2.1 The primary master switch must:

- a. Be located on the (driver's) right side of the vehicle, in proximity to the Main Hoop, at shoulder height and be easily actuated from outside the car.



- b. Disable power to ALL electrical circuits, including the battery, alternator, lights, fuel pump(s), ignition and electrical controls.
- c. All battery current must flow through this switch.
- d. Be of a rotary type and must be direct acting, i.e. it cannot act through a relay.

An example of a typical switch that meets these requirements is shown below.



IC4.2.2 The "OFF" position of the primary master switch must be clearly marked.

### **IC4.3 Cockpit-mounted Master Switch**

IC4.3.1 The cockpit-mounted master switch:

- a. Must be located to provide easy actuation by the driver in an emergency or panic situation.
- b. Must be located within easy reach of the belted-in driver, alongside the steering wheel, and unobstructed by the steering wheel or any other part of the car. It is suggested that it be placed on the same side of the steering wheel as the shifter mechanism.
- c. Must be a push/pull Emergency switch. The switch must be installed such that:
  - i. From the ON position, pushing on the switch will disable power to the ignition and all fuel pumps, and
  - ii. From the OFF position, pulling on the switch will enable power to the ignition and fuel pump(s). Switches that require a twist or twist and pull to enable power are acceptable.
- d. May act through a relay.

Examples of typical switches that meet these requirements are shown below.



#### IC4.4 Batteries

IC4.4.1 All batteries, i.e. on-board power supplies, must be attached securely to the frame.

IC4.4.2 Any wet-cell battery located in the driver compartment must be enclosed in a nonconductive marine-type container or equivalent.

IC4.4.3 The hot (*ungrounded*) terminal must be insulated.

IC4.4.4 Battery packs based on Lithium Chemistry other than Lithium Iron Phosphate (LiFePO4): a. must be commercially manufactured items

- b. must have over voltage, under voltage, short circuit and over temperature cell protection
- c. must be separated from the driver by a firewall

IC4.4.5 All batteries using chemistries other than lead acid must be presented at technical inspection with markings identifying it for comparison to a datasheet or other documentation proving the pack and supporting electronics meet all rules requirements

#### IC4.5 Brake-Over-Travel-Switch

The Brake-Over-Travel-Switch forms part of the shutdown system and as defined in T7.3 must kill the engine and fuel pumps.

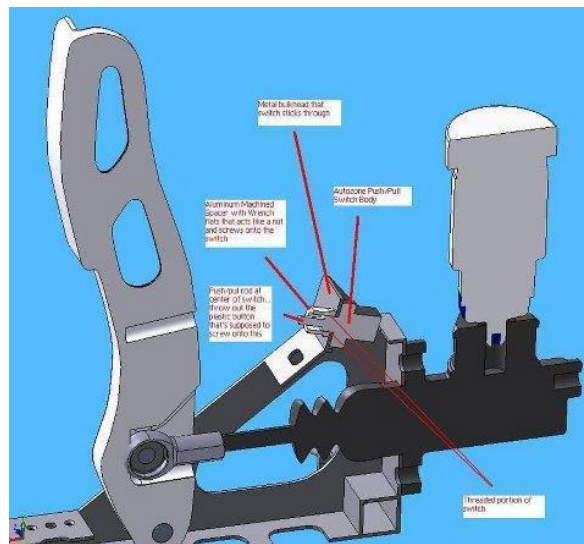

## 2018 STUDENT FORMULA

### PART S - STATIC EVENT REGULATIONS

#### ARTICLE 1: STATIC EVENTS AND MAXIMUM SCORES

The maximum possible scores in the static events are:

Technical Inspection	No Points
Cost and Manufacturing	100 Points
Presentation	75 Points
<u>Design</u>	<u>150 Points</u>
Total	325 Points

#### ARTICLE 2: TECHNICAL INSPECTION S2.1

##### Objective of Technical Inspection

The objective of technical inspection is to determine if the vehicle meets the STUDENT FORMULA Rules requirements and restrictions and if, considered as a whole, it satisfies the intent of the Rules.

S2.1.1 For purposes of interpretation and inspection the violation of the intent of a rule is considered a violation of the rule itself. (See Rule A3.6)

S2.1.2 Technical inspection is a non-scored activity.

##### S2.2 Inspection & Testing Requirement

Each vehicle must pass all parts of technical inspection and testing, and bear the inspection stickers, before it is permitted to participate in any dynamic event or to run on the practice track.

S2.2.1 All items on the Inspection Form must be clearly visible to the technical inspectors.

S2.2.2 Visible access can be provided by removing body panels or by providing removable access panels.

##### S2.3 Team Responsibility

Teams are responsible for confirming that their vehicle, and the required equipment, satisfies the requirements and restrictions of the SUPRASAEINDIA Rules before presenting it for Technical Inspection.

S2.3.1 Presenting a vehicle for Technical Inspection constitutes a declaration by the team that they have determined by self inspection that the vehicle complies with the Rules.

##### S2.4 Items to be Inspected

The following items **must** be brought to Technical Inspection:

- Vehicle
- Technical Inspection Form

- Dry and wet tires
- Driver's equipment - for all drivers including arm restraints, helmets, suits, gloves, eye protection, balaclavas, socks and shoes.
- Fire extinguishers
- Push bar
- Structural Equivalency Spreadsheet (SES) copies as appropriate for your car.
- Impact Attenuator Report copies
- Copies of any rules questions you submitted with the answer you received.
- All drivers must be present at inspection.

## **S2.5 Technical Inspection Procedure**

Technical inspection will examine all items included on the Inspection Form found on the SUPRASAEINDIA website plus any other items the inspectors may wish to examine to ensure conformance with the Rules. The exact procedures and instruments employed for inspection and testing are entirely at the discretion of the Chief Technical Inspector.

S2.5.1 Decisions of the inspectors and the Chief Technical Inspector concerning vehicle compliance are final and are not permitted to be appealed.

## **S2.6 Inspection Condition**

Vehicles must be presented for technical inspection in finished condition, i.e. fully assembled, complete and ready-to-run. Technical inspectors will not inspect any vehicle presented for inspection in an unfinished state.

**Note:** Cars may be presented for technical inspection even if final tuning and set-up has not been finished.

## **S2.7 Inspection Process**

Vehicle inspection will consist of three separate parts as follows:

### **S2.7.1 Part 1 - Mechanical Scrutineering**

Each vehicle will be inspected to determine if it complies with the requirements of the rules. This inspection will include examination of the driver's equipment (Part T Article 14) and a test of the driver egress time (Rule T4.8).

Part 1 must be passed before a vehicle may apply for Part 2 and Part 3 inspection.

### **S2.7.2 Part 2 - Tilt Table Tests**

Each vehicle will be tested to insure it satisfies both the forty-five degree (45°) fuel and fluid tilt requirement (Rule T8.5) and the sixty degree (60°) rollover stability requirement (Rule T6.7.2).

Parts 1 and 2 must both be passed before a vehicle may apply for Part 3 inspection.

### S2.7.3 Part 3 - Noise, Master Switch, Ready-To-Drive-Sound, Rain Test and Brake Tests

IC Vehicles - Noise will be tested by the specified method (Rule IC3.2). If the vehicle passes the noise test then its master switches (Rule IC4.1) will be tested.

## S2.8 Correction and Re-inspection

S2.8.1 If any part of a vehicle does not comply with the Rules, or is otherwise deemed to be a concern, then the team must correct the problem and have the car re-inspected.

S2.8.2 The judges and inspectors have the right to re-inspect any vehicle at any time during the competition and require correction of non-compliance.

## S2.9 Inspection Stickers

Inspection stickers issued following the completion of any part of Technical Inspection will be placed on the upper nose of the vehicle as specified in Rule T13.4 "Technical Inspection Sticker Space".

S2.9.1 Inspection stickers are issued contingent on the vehicle remaining in the required condition throughout the competition.

S2.9.2 Inspection stickers may be removed from vehicles that are not in compliance with the Rules or are required to be re-inspected.

## S2.10 "As-Approved Condition"

Once a vehicle has passed inspection, except as specifically allowed under Rule T1.2 "Modification and Repairs", it must remain in the "As-approved" condition throughout the competition and must not be modified.

## S2.11 Inspection Validity

Technical approval is valid only for the duration of the specific STUDENT FORMULA competition during which the inspection is conducted.

## ARTICLE 3: BUSINESS LOGIC CASE

### S3.1 The Objectives of the Business Logic Case are to:

- a. Teach participants about the factors that need to be considered when a company embarks on development of a new product. These include: cost; identification of market and likely sales volume; profitability; the key features applicable to the selected vehicle concept and target market size.
- b. Ensure teams develop the concept of their entry with all of these aspects correctly considered, from the outset.
- c. Ensure that all three static events are approached with a single common concept and presented to each set of static judges in the same manner.
- d. Ensure that participants gain experience in producing a business case and balancing potentially conflicting attributes.

**S3.2 The Design, Cost and Business Presentation judges will use the business logic case to verify that the information presented at each static event is consistent with the overall objectives as outlined in the Static Events Rules.**

- a. In the Design event, the business logic case will be used to identify how the team determined the trade off between design for performance and design for manufacture and cost, how these requirements were considered in the overall concept and whether these were achieved in the final vehicle.
- b. In the Cost event, the business logic case will be used to determine that the cost target was met for the same design solution and how Cost was integrated into the overall concept and the iterative design process.
- c. In the Business Presentation event, the business logic case will be used to assess whether the business presentation is appropriate for the market and business strategy that the team has identified

**S3.3 All teams must submit a Business Logic Case report in accordance with the general format applicable for the year of competition " SUPRA SAEINDIA Business Logic Plan 201X".** The report must be submitted on the template. Refer to the applicable competition website to acquire the template.

**This report must be submitted** by the deadline which will generally be ~ 6-9 months before the competition. Refer to the deadlines posted on the website for each specific competition.

#### **ARTICLE 4: COST AND MANUFACTURING EVENT**

**Important Notice: Additional information about the Cost and Manufacturing Event including Cost Tables and other information can be obtained from the [www.suprasaeindia website](http://www.suprasaeindia.com) which is also linked off the STUDENT FORMULA Rules and Important Documents page on the SUPRASAEINDIA Website.**

##### **S4.1 Event Objective**

The objectives of the Cost and Manufacturing Event are:

- a. To teach the participants that cost and budget are significant factors that must be considered in any engineering exercise.
- b. For teams to make trade off decisions between content and cost based on the performance advantage of each part and assembly.
- c. To gain experience with creating and maintaining a Bill of Material (BOM).
- d. For the participants to learn and understand the principles of Design for Manufacture and Assembly, lean manufacturing and Minimum Constraint Design.

#### **S4.2 Rules Objective**

The objectives of the Cost and Manufacturing Event rules are:

- a. To provide a logical, simple and time efficient rule set enabling students to achieve the event's objectives.
- b. To improve fairness by providing consistent pricing guidelines independent of team geographical location by using standardized Cost Tables.
- c. To require the minimal burden of supporting documentation such as receipts or catalog pages. However, in order to convey design information to cost judges engineering documentation (drawings, process descriptions, etc) are required.

#### **S4.3 Event Requirements**

This event is comprised of three (3) parts

##### **S4.3.1 Part 1 "Cost Report"**

The preparation and submission of a report (the "Cost Report"), which is to be sent to the Cost Judges prior to the competition. See S4.1.

##### **S4.3.2 Part 2 "Discussion"**

1. A discussion at the Competition with the Cost Judges around the team's vehicle. See Section S4.3.2. This evaluates not only the cost of the car, but also the team's ability to prepare accurate engineering and manufacturing cost estimates and team's knowledge about the BOM"

##### **S4.3.3 Part 3 Cost report preparedness**

Cost Judges will evaluate the cost report submitted by the team.]

#### **S4.5 Public Cost Reports**

By submitting a cost report to the competition's organizing body for judging you and your team agree that your cost report can be reproduced and distributed by the competition organization, in both complete and edited versions, in any medium or format anywhere in the world.

Note: For the 2018 competition season it is the plan of the STUDENT FORMULA Rules Committee and the competition organizers to publish all cost reports, in as-submitted format, to the SUPRASAEINDIA website. It is the intent of this move to make the cost event more transparent and improve the educational experience of the students by providing the full range of cost reports for teams to review. Cost reports for that competition season will not be published before the end of the calendar year. Support materials, such as technical drawings, will not be released.

#### **S4.6 Definitions**

The following definitions will apply throughout the Cost Event rules:

S4.6.1 Adjusted Cost - The final cost for the vehicle including penalties

S4.6.2 Amended Cost - The cost of the vehicle after modification by the competition addendum

S4.6.3 Bill of Material - A hierarchical list of all parts of the vehicle. A BOM lists every item that is on the vehicle but also shows the relationships between these items, for example showing the parts that make up an assembly. A Costed Bill of Material (CBOM) is a standard BOM that includes cost information including cost of purchased parts, raw materials and processes that go into manufacturing the vehicle.

S4.6.4 Category - Each table has numerous entries which describe a classification of entry. For example there are several types of hose clamps, and all have various costs. The category of hose clamp may be worm drive, constant tension, etc.

S4.6.5 Cost - The cost for each item from the materials table is simply the quantity multiplied by the unit cost.

S4.6.6 Cost Report - All materials, including electronic and hard copy, submitted for judging

S4.6.7 Cost Score - Refers to the total number of points out of 100 earned in the Cost Event

S4.6.8 Cost Tables - All tables that list costs for objects and processes

S4.6.9 Design for Manufacture and Assembly (DFMA) - The process where parts are designed for ease of manufacture and assembly, resulting in lower cost.

S4.6.10 Fasteners Table - A Cost Table that consists of not only traditional fasteners such as bolts, nuts and rivets but also adhesives, hose clamps and retaining rings.

S4.6.11 Fixed Cost - Costs associated with production that are independent of volume produced. Fixed cost items, such as tooling, are converted to variable costs when included in the Cost Report.

S4.6.12 Initial Cost - The cost of the vehicle submitted for initial judging in the Cost Report.

S4.6.13 Lean Manufacture - A methodology for producing goods that emphasizes the elimination of waste and improvement in process flow with the goal of optimizing the cost and quality of goods.

S4.6.14 Materials Table - Lists the costs for raw materials used to manufacture parts built by the teams and also of finished parts purchased by the teams.



- S4.6.15 Minimum Constraint Design (MCD) - A design methodology emphasizing elimination of redundant constraints in the attachment of parts. Each part requires constraint in six degrees of freedom and additional constraints can make assembly difficult, force tight tolerances and increase the cost of manufactured goods.
- S4.6.16 Parameters - Used to create an equation describing the cost of an object as a function of some characteristic of that object. For example the cost of steel is proportional to the mass (or volume) of steel. In this case steel has been parameterized by mass. Rubber hose could be parameterized by diameter. The equations can be linear or non-linear and both 1st and 2nd order equations are used as necessary to build the Cost Tables.
- S4.6.17 Process Multipliers - Modify the standard costs of different operations to account for material and geometric differences in the part.
- S4.6.18 Purchased Parts - Also called bought parts; these items are listed in the Cost Tables in a near as-installed condition. For example wheels, engines and turbochargers are purchased parts. In some cases purchased parts may still require additional processing before they can be assembled to the car. Wheels, for example, do not include the machined features for mounting to the hub. Purchased parts do not include fasteners unless specifically noted in the Cost Tables.
- S4.6.19 Quantity - The amount of the item
- S4.6.20 Raw Materials - Materials used for manufacturing parts, such as aluminum, steel and rubber hose.
- S4.6.21 Tools - Tools refer to hand or power tools used to assemble the vehicle. The costs of these tools **are not included** in the Cost Report. The effect of the tools used for assembly are captured in the process tables for labor as different costs are given based on the tools used for assembly.
- S4.6.22 Tooling - Is the production tooling associated with processes that are specific to the part geometry. The costs of tooling **must be included** in the Cost Report. For example the dies to stamp out a chassis bracket are tooling. The press used to stamp the bracket is not, and is considered production equipment which is not part of the Cost Event.
- S4.6.23 Unit - Is the measurement system used to define the quantity of a parameter.  
For example millimeters and kilograms are units. The hose clamp diameter unit is mm. When calculating the cost of the clamp the unit of measurement used by the team must match the Unit specified in the tables. For example a US team mistakenly calculates the hose clamp cost by using the expression with a diameter of 1, because their radiator hose is 1 inch in diameter. They should have used 25.4mm for the diameter and their cost is wrong because of it. For the penalties associated with this type of error see S4.19

S4.6.24 Unit Cost - Is the cost for something assuming a numerical value of one (1) of the unit used to measure the item. The cost is the quantity of an item multiplied by the unit cost.

S4.6.25 Variable Cost - Is a cost associated with production that is proportional to the vehicle volume produced. All costs submitted with the Cost Report will be variable costs.

#### **S4.7 General Requirements**

S4.7.1 The Cost Report must:

- a. Use the standardized Cost Tables. The tables are designed to reflect a hypothetical car built for production at the annual volume of 1000 units per year.
- b. List and cost every part on the prototype vehicle. This includes any equipment fitted on the vehicle at any time during the competition. The only exceptions are that, per S4.23 "Cost Report Exempt Items" of the Rules, the cost of any finish, on-board fire suppression system, rain tires, video or radio system, does not need to be included in the Cost Report.
- c. Be based on the estimated costs of materials, fabrication, purchased parts, and assembly of the car. The costs shall be calculated as defined in these rules.
- d. Be based on the actual manufacturing technique used on the prototype, e.g. cast parts on the prototype must be cost as cast, and fabricated parts as fabricated, etc.
- e. Include tooling (e.g. welding jigs, molds, patterns and dies) for processes requiring it.
- f. Exclude R & D and capital expenditures (e.g. plant, machinery, hand tools and power tools).

**Note:** There is no maximum cost. Receipts are not required for any items.

S4.7.2 The Cost Tables have been designed to:

- a. Be verifiable at the event. Differentiating between different types of materials (for example different alloys of steel) is not possible so no differentiation is made in the table cost.
- b. Minimize influence on safety equipment content. For example driver harnesses are cost independent of the style chosen.
- c. Higher costs of some goods must reflect actually higher value of those goods. However, the costs must still allow for team innovation and vehicle content, with some reduction in cost score.

### S3.8 Scoring

The points for the Cost and Manufacturing Event will be broken down as follows:

$40x\left[\frac{(P_{max})}{(P_{your})}-1\right]$ $\left[\frac{(P_{max})}{(P_{min})}-1\right]$	40 Points	Lowest cost - each of the participating schools will be ranked by total adjusted cost from the BOM and given 0-40 points based on the formula on the left.
	40 Points	Accuracy, Clarity & Event Day/Visual Inspection - The cars will be reviewed for part content, manufacturing feasibility and accuracy of the cost information. Supporting documentation will be assessed based on its quality, accuracy and thoroughness. The range for the score is 0-40 points.
	20 Points	Cost report preparedness- It will be judged on the basis of How well teams has prepare their cost report and how well team will be able to explain the content of their reports, Whether report is as per the cost template provided to teams).
Total	100 Points	

Where:

P<sub>your</sub> is the adjusted cost of your car (with penalties) in INR.

P<sub>min</sub> is the adjusted cost of the lowest cost car in INR.

P<sub>max</sub> is the cost of the highest cost car in INR.

### S4.9 Cost Report

S4.9.1 The Cost Report consists of a full vehicle BOM with cost data derived from the Cost Tables and supporting documentation. The Cost Report must be submitted in two (2) forms:

- a. Electronic Version- The Electronic Version must be identified as follows:  
Carnumber\_collegename\_competitioncode\_CR.xls using the assigned car number, the complete college name and the competition code.

Example: 087\_university of STUDENT\_SUPRA SAEINDIA\_CR.xls

#### S4.9.2 Cost Report Identification

The cover of the Cost Report must include the following:

- (a) university name, (b) competition name, and (c) vehicle number.

S4.9.3 The Cost Report must consist of the following:

- A Cover sheet
- A Table of Contents
- A Cost Summary page listing each section's cost, and the total vehicle cost

- Eight commodity report sections with the parts placed in the sections as specified in Appendix S-3.
- Tabs for each section

#### S4.10 Bill of Materials (BOM)

The BOM is a parts list for every vehicle part. It also shows the relationships between the items.

S4.10.1 The following terminology will be used when referring to the BOM.

- The overall vehicle is broken down into eight (8) systems which are defined in Appendix S-3.
- Systems are made up of Assemblies.
- Assemblies are made up of Parts.
- Parts consist of materials, processes and fasteners.
- Tooling is associated with each process that requires production tooling.

S4.10.2 An example BOM structure is shown below:

- |                         |          |
|-------------------------|----------|
| • Engine & Drivetrain   | System   |
| ○ Engine                | Assembly |
| ○ Differential          | Assembly |
| ▪ Housing               | Part     |
| ▪ Aluminum              | Material |
| ▪ Needle Bearing        | Material |
| ▪ Sand cast             | Process  |
| • Die & Core Package #4 | Tooling  |
| ▪ Machining-Turn        | Process  |
| ▪ Weld                  | Process  |
| ▪ M6x1.25 Grade 8.8     | Fastener |
| ▪ Internals             | Part     |
| ▪ End Cap               | Part     |

The BOM must follow the format given above. There must be no other BOM levels added or any removed. Deviations from the structure published will be penalized per Section S4.18.

S4.10.3 All assemblies, parts and fasteners in the BOM must use a standard numbering convention explained in Appendix S-2.

#### S4.11 The Cost Tables

S4.11.1 All costs in the Cost Report come from the standardized Cost Tables. These tables have been compiled to represent the cost of parts and processes that a manufacturing company

could be expected to pay for manufacturing a vehicle at 1000 units per year. Generally, the tabulated value represents  $\frac{1}{2}$  of the Manufacturer's Suggested Retail Price (MSRP) for finished parts. Raw materials, commodities and fasteners also intended to represent the production volume of a company rather than the purchase price of the University teams.

S4.11.2 Requests to alter the cost of goods in the tables because of changing world markets or individual team purchase price will not be approved. The tables are intended to provide a fair, unchanging (within a given competition year) cost for parts and to reduce regional variations in price that may help or hurt certain teams. All teams must use the costs given in the tables. If a team wishes to use any parts, processes or materials not included in the tables an "Add Item Request" must be submitted as per Section S4.14.

S4.11.3 The tables represent cost based on specific parameters. For example the cost of steel is given per unit of volume (or mass). Likewise, engine costs are listed by displacement and specific power output.

S4.11.4 The following Cost Tables are used

- Materials
- Processes
- Process Multipliers
- Fasteners
- Tooling

S4.11.5 In general, most items have a cost expressed as a function of one parameter. In cases where more than one parameter is necessary additional categories are listed. For example the power output of the engine has three Categories and for each Category a different expression calculates the cost as a function of the engine displacement, which is the Parameter. The Unit would be cubic centimeters in this case.

S4.11.6 Process Multipliers are used to modify the standard costs of different operations to account for material and geometric differences in the part. For every process included in the Cost Report the list of process multipliers must be checked to determine if any apply, and if they do their effect on the cost must be included.

S4.11.7 When adding items from tables to the BOM the comments section should be reviewed thoroughly to understand what is included in the table entry. For example is the spring included in the damper cost? Do the spark plugs come with the engine or are they a separate line item? In cases where the explanation is not clear please contact the Rules Committee for clarification.

#### **S4.12 Cost Models & Costing Methodology**

The cost models are the underlying methodology and equations that relate the final cost of a part or process to the different operations and goods used in that part. The detailed

explanation of the Cost Models and Costing Methodology is included in Appendix S-1 and should be referenced for understanding the use of the Cost Tables.

#### S4.13 Make Versus Buy

Every part on an individual car can be classified as "made" or "bought". This designation does not necessarily refer to whether a team actually purchased or fabricated a part but is a reflection of how the part must be cost from the Cost Tables.

- a. Made (or manufactured) parts must be cost as if the company manufacturing the vehicle was going to make the part internally. That is by purchasing raw materials and processing them into a finished product.
- b. Bought parts must be cost as if the company manufacturing the vehicle was going to outsource the fabrication of that part. These parts would be received by the vehicle manufacturer in a relatively finished state (see the particular table entry comments field for specific information).

S4.13.1 The Cost Tables have been constructed as a tradeoff between complexity for the organizers and fairness for the teams. The make versus buy designation enables certain parts to be simplified to a relatively few number of entries. For example some teams may purchase axles but the majority of teams manufacture them. Axles are designated "make" parts so teams that purchase axles **must** cost them as if they had made them starting with the raw materials, in this case probably steel tubing. Made parts can be distinguished because they do not appear explicitly in the Cost Tables or appear with a "cost as made" option.

S4.13.2 If a team genuinely makes a part listed on the table as a bought part they may alternatively cost it as a made part **if and only if** a place holder entry is listed in the tables enabling them to do so. For example, in the category of dampers a "student built" entry is included. This line item must be included in the BOM (it has zero cost). Then they must proceed to cost the damper they actually designed and built.

S4.13.3 A table summary of options is given below:

How Table Lists Part	How Team Actually Acquired the Part	
	Team Made	Team Bought
Table Lists Part as "Made", or Part is not Listed in the Tables	Cost as "Made"	Cost as "Made"
Table Lists Part as "Bought"	Team made option NOT in table cost as "Bought". If team made option in table team can choose either "Bought" or "Made"	Cost as "Bought"

S4.13.4 For example a snap ring does not have a "team made" entry in the Cost Tables. A team who made their own would still have to use the table cost based on diameter, even if they could cost it less expensively by buying steel and processing it.

S4.13.5 Any part which is normally purchased that is optionally shown as a made part must have supporting documentation submitted to prove team manufacture. This might include engineering drawings, pictures of machining, etc. Teams found costing bought parts as made parts will be penalized appropriately.

#### **S4.14 Add Item Request**

S4.14.1 The costs tables are intended to include all materials, processes and fasteners needed by the teams to accurately reflect the content, manufacture and assembly of their vehicle. However, it will be necessary to add items to the tables to suit individual team requirements. To do this an "Add Item Request" must be submitted to the Rules Committee. After review the item will be added to the tables with the next table update with a cost appropriate to the overall Cost Table framework and spirit of the competition.

The tables will be updated throughout the competition year as required.

S4.14.2 The form should be completely filled out and contains the necessary instructions. Some supporting documentation will be required such as receipts or website links. The Add Item request is the only time receipts will be needed for the Cost Event.

**Note:** Since all teams work off the same tables once a team requests an item be added to the tables all teams will see the addition. Any team using the newly added item will use the same cost. The identity of the school that made the request will not be published.

#### **S4.15 Report Submission and Deadline**

- a. The Cost Report must be submitted in the designated format for each event.
- b. For some events, a printed copy of the report must also be submitted and must be on 8 1/2 inch x 11 inch or A4 size paper, using a 10-point font size or larger.
- c. Submission Address and Deadline - The submission requirements, address and deadline will be published in the appendix or released on the website of the specific competition.

#### **S4.16 Late Submission of Cost Report**

It is imperative that the cost judges have the Cost Reports in enough time for proper evaluation. Teams that submit reports late will be penalized as per rule A8.4

#### S4.17 Addenda

S4.17.1 An addendum that reflects any changes or corrections made after the submission of the Cost Report must be submitted at Registration when the Team registers on-site at the Event. It will not be accepted at any other time or place. The addendum document must follow the template format specified in Appendix C-5. No other format will be accepted.

S4.17.2 Addenda apply only to the competition at which they are submitted. A separate addendum is permitted for every competition a vehicle attends.

S4.17.3 Any items added to the Cost Report through addenda will be cost at 1.25 times the table cost. Any items removed through addenda will only be credited 0.75 times the table cost.

**Note:** Late changes to designs impact costs in the real world. Contracts need to be altered, commodity costs can change, cancellation fees may be incurred and information needs to be transmitted to suppliers. The scaling factors for the addenda capture this as well as encourage teams to submit full and accurate information with the initial Cost Report.

#### S4.18 Cost Report Judging and Penalties Process

S4.18.1 The following procedure will be used in determining penalties:

1. Penalty A will be calculated first using procedure S4.19
2. Penalty B will then be calculated using alternative procedure S4.20
3. The greater of the two penalties will be applied against the cost score
  - a. Penalty A expressed in points will be deducted from the Accuracy score
  - b. Penalty B expressed in INR will be added to the Adjusted Cost of the vehicle
4. If no additional points remain to be deducted from the Accuracy score the penalty will be applied using method B against the Adjusted Cost

S4.18.2 If the alternative penalty is used because no additional accuracy points remain then the highest of the A type penalties will be converted to B type penalties. In effect, the order the penalties are calculated and applied against the team does not matter.

S4.18.3 Any error that results in a team over reporting a cost in their Cost Report will not be further penalized. For example, when the Cost Report is prepared the thickness of the brake rotors has not yet been determined. The team conservatively costs the rotors as 10mm thick. The final thickness is 8mm and no change is made in the addendum. The team rotor price is higher than necessary but no penalty is applied.

**Note:** The penalty system is intended to reward accuracy and minimize workload at the competition for students and judges. In most cases the standard points deductions will be made to the accuracy score.

**Note:** Any instance where a team's score benefits by an intentional or unintentional error on the part of the students will be corrected on a case by case basis.



#### S4.19 Penalty Method A- Fixed Point Deductions

S4.19. From the Bill of Material, the cost judges will determine if all parts and processes have been included in the analysis. In the case of any omission or error the judges will add a penalty proportional to the BOM level of the error.

The following standard points deductions will apply:

- Missing/inaccurate material, process, fastener 1 pt.
- Missing/inaccurate part 3 pt.
- Missing/inaccurate assembly 5 pt.

**Note:** Each of the penalties listed above supersedes the previous penalty. If a 5 point deduction is given for a missing assembly the missing parts are ignored for Method A. Method B would include the cost of the missing parts in the calculation.

S4.19.2 Differences other than those listed above will be deducted at the discretion of the cost judges. Examples of errors leading to points deductions:

- Five M6 fasteners listed, six used - 1 pt.
- Three kilograms of steel listed, 4.4 used - 1 pt.
- Bearing carrier face machined, mill operation not included - 1 pt.
- Installation labor for steering wheel missing - 1 pt.
- Upright cost as cast but actual part billet machined - 3 pt.
- Pneumatic shifter not included on BOM - 5 pt.

The penalties above will be deducted from the points awarded for Accuracy of the Cost Report.

#### S4.20 Penalty Method B - Adjusted Cost Deductions

The alternative penalty will be calculated using the following equation:

$$\text{Penalty} = 2 \times (\text{Table Cost} - \text{Team Reported Cost})$$

The table cost will be calculated from the standard Cost Tables. The penalty calculation will result in a dollar value equal to twice the difference between the team cost and the correct cost for all items in error.

This penalty, if applied, will be made to the Adjusted Cost of the vehicle.

**Note:** The table costs of all items in error are included in the calculation. A missing assembly would include the price of all parts, materials, processes and fasteners making up the assembly.

#### S4.21 Penalty Calculation Example

For example the pneumatic shifter was inadvertently left off the Cost Report. As this is an assembly the standard error is 5 points. The cost of all air shifter parts and processes from

the Cost Tables is `500. This means the total penalty cost is `1000. To see which is greater, 5 points or `1000, the INR penalty needs to be converted to points by reference to the Cost Points formula:

$$\text{Points} = \frac{40 \times [(P_{\text{max}})/(P_{\text{your}}) - 1]}{[(P_{\text{max}})/(P_{\text{min}}) - 1]}$$

Substitute the cost of the vehicle ( $P_{\text{your}}$ ) with `15,000 while the minimum vehicle cost ( $P_{\text{min}}$ ) was `10,000. The maximum vehicle cost ( $P_{\text{max}}$ ) was `50,000. Calculating the points equivalent for this Rupee amount yields 2.5 points. This is less than the standard penalty. In this case the 5 points would be deducted from the Accuracy score.

If the team had made many small errors and had no more accuracy points available then the `1000 would be added to the team's adjusted cost.

#### **S4.22 Discussion at the Competition**

S4.22.1 At this discussion, the Cost Judges will:

- a. Review whether the specification of the vehicle in the Cost Report accurately reflects the vehicle brought to the Competition
- b. Review the manufacturing feasibility of the vehicle
- c. Assess penalties for missing or incorrect information in the Cost Report compared to the vehicle presented at inspection.

S4.22.2 The team must present their vehicle at the designated time to the Cost Judges for review of the Cost Report. Teams that miss their cost appointment will potentially lose all cost points for that day. The schedule for these appointments will be in the registration packets and/or posted on the website.

#### **S4.23 Cost Report Exempt Items**

S4.23.1 Finishes

The car will be considered to be shipped as primed or gel coated and a cost recorded. Any finishes (paint, polish, etc.) that are only used to beautify need not be costed. Preservative finishes intended to protect the appearance or function of a part for an extended period of time must be costed (labor and material included).

S4.23.2 Fire Extinguisher and Suppression System

Hand held fire extinguishers are not allowed on the vehicle (See Rule T14.14 "Fire Extinguishers"), but if the car has an on-board fire suppression system, it is not required to be costed.

S4.23.3 Tires and Wheels

Only one set of tires and wheels needs to be included in the Cost Report. The tires and wheels that are declared as dry tires per rule T6.4 "Tires" must be the tires included in the

Cost Report, and must be the tires on the car during the Cost Event judging. Other tires that will be potentially used at the competition (i.e. rain tires) do not need to be included in the Cost Report.

#### S4.23.4 Transponders, Video and Radio Systems

Transponders, video and radio systems, need not be included in the Cost Report.

#### S4.23.5 Data Acquisition Systems

Data acquisition systems must be included in the Cost Report using the published table costs. This includes display screens, control modules and all sensors. The table costs for control modules and screens have been set to match an equivalent product **without** the data acquisition functionality. In essence, "stand-alone" data acquisition systems excluding sensors and wiring will have no influence on vehicle cost. Systems that include driver displays or other vehicle control functionality will have the cost of those features included in the total vehicle cost.

In summary, all data acquisition systems, sensors and wiring must be included in the Cost Report using the Cost Table prices.

### S4.24 Exchange Rates & Unit Systems

The currency of the Cost Report will be referred to as INR. Since all items have a cost from the Cost Tables the actual currency unit is irrelevant.

S4.24.1 All Cost Tables are presented using metric units. The tables do not differentiate between parts designed in metric and US systems of measure. For example "a ¼ bolt" is simply input as a 6.35mm bolt. Tubing with a wall thickness of 0.035 inches is input as 0.889mm tubing. All sizes are assumed to be standard for the part being cost and no surcharge applies for any size, even if the size is non-standard. For example a team makes a custom 6.112mm bolt which took several hours of student time. However, this bolt is chosen from the Cost Tables and is less than one Rupee. The assumption is in high volume production these bolts would be purchased in bulk.

S4.24.2 The comment section for each material, process or fastener may, at the student's discretion, refer to the specific part by actual local designation. For example a 6.35mm bolt is cost but the comments would say "¼inch A-arm bolt".

S4.24.3 Because the Cost Report reflects a production cost for 1000 units per year all material and commodity sizes are assumed to be available for the necessary volume without cost penalty.

---

## **ARTICLE 5: PRESENTATION EVENT**

### **S5.1 Presentation Event Objective - Business Case**

S5.1.1 The objective of the presentation event is to evaluate the team's ability to develop and deliver a comprehensive business case that will convince the executives of a corporation that the team's design best meets the demands of the amateur, weekend competition market, and that it can be profitably manufactured and marketed. (See also A1.2)

S5.1.2 The judges should be treated as if they were executives of a corporation.

S5.1.3 Teams should assume that the "executives" represent different areas of a corporate organization, including engineering, production, marketing and finance, and thus may not all be engineers.

S5.1.4 Presentations will be evaluated on the contents, organization and visual aids as well as the presenters' delivery and the team's response to questions.

S5.1.5 The presentation must relate to the car entered into the competition and although the actual quality of the prototype itself will not be considered as part of the presentation judging, the presentation must be consistent with the Business Logic Case that is submitted prior to the competition.

### **S5.2 Presentation Schedule**

S5.2.1 Presentations will be made on the static events day. Presentation times will be scheduled by the organizers and either, or both, posted in advance on the competition website or released during on-site registration.

S5.2.2 Teams that fail to make their presentation during their assigned time period will receive zero (0) points for the event.

### **S5.3 Presentation Format**

S5.3.1 One or more team members will give the presentation to the judges.

S5.3.2 All team members who will give any part of the presentation, or who will respond to the judges' questions, must be in the podium area when the presentation starts and must be introduced to the judges. Team members who are part of this "presentation group" may answer the judge's questions even if they did not speak during the presentation itself.

S5.3.3 Presentations are limited to a maximum of twenty (20) minutes. The judges will stop any presentation exceeding ten minutes.

S5.3.4 The presentation itself will not be interrupted by questions. Immediately following the presentation there will be a question and answer session of up to five (5) minutes.

S5.3.5 Only judges may ask questions. Only team members who are part of the "presentation group" may answer the judges' questions.

#### **S5.4 Data Projection Equipment**

S5.4.1 Projection equipment is provided by the organizers.

#### **S5.5 Evaluation Criteria**

S5.5.1 Presentations will be evaluated on content, organization, visual aids, delivery and the team's response to the judges' questions. The scoring criteria are detailed in Appendix S-6 "Presentation Judging".

S5.5.2 The criteria are applied only to the team's presentation itself. The team that makes the best presentation, regardless of the quality of their car, will win the event.

#### **S5.6 Scoring Formula**

S5.6.1 The Presentation Events score is based on the average of the judges' scores.

S5.6.2 There is a maximum of fifty (50) points from the Presentation Judging Form.  $PRESENTATION\ SCORE = 75 \times P_{your}/P_{max}$

Where:

"P<sub>max</sub>" is the highest score awarded to any team  
"P<sub>your</sub>" is the score awarded to your team

S5.6.3 It is intended that the scores will range from near zero (0) to seventy-five (75) to provide good separation.

S5.6.4 The Presentation Event Captain may at his/her discretion; normalize the scores of different judging teams.

#### **S5.7 Presentations without a Completed Car**

Teams that unable to bring a vehicle to the competition may participate in the Presentation Event and will receive a score for that event.

Note: Participating in the Presentation event without bringing a vehicle to the competition will not affect the status of the car you have under construction at your school. When you finish it and bring it to a competition it will still be a first year vehicle under Rules A6.6 and A6.8

### **ARTICLE 6: DESIGN EVENT**

#### **S6.1 Design Event Objective**

S6.1.1 The concept of the design event is to evaluate the engineering effort that went into the design of the car and how the engineering meets the intent of the market.

S6.1.2 The car that illustrates the best use of engineering to meet the design goals and the best understanding of the design by the team members will win the design event.

**Comment:** Teams are reminded that SUPRA SAEINDIA is an engineering design competition and that in the Design Event; teams are evaluated on their design. Components and systems that are incorporated into the design as finished items are not evaluated as a student designed unit, but are only assessed on the team's selection and application of that unit. For example, teams that design and fabricate their own shocks are evaluated on the shock design itself as well as the shock's application within the suspension system. Teams using commercially available shocks are evaluated only on selection and application within the suspension system.

S6.1.3 The design judges may also consult the Business Logic Case that is submitted before the event. It is expected that the car that is presented at the design event should reflect the design concept that is developed in the Business Logic Case.

## **S6.2 Design Report - Required Submission**

S6.2.1 Design Report - Judging will start with a Design Review before the event. The principal document submitted for Design Judging is a Design Report.

S6.2.2 The Design Report must not exceed twelve (12) pages, consisting of not more than Eight (8) pages of text, three (3) pages of drawings and one (1) optional page containing content to be defined by the team (photo's, graphs, etc..). Final Format will be released afterward.

S6.2.3 The document should contain a brief description of the vehicle with a review of your team's design objectives, a discussion of any important design features and vehicle concepts. Include a list of different analysis and testing techniques (FEA, dynamometer testing, etc.). Evidence of this analysis and back-up data should be brought to the competition and be available, on request, for review by the judges.

S6.2.4 These documents will be used by the judges to sort teams into the appropriate design groups based on the quality of their review.

**Comment:** Consider your Design Report to be the "resume of your car".

## **S6.3 Design Spec Sheet - Required Submission**

S6.3.1 Design Spec Sheet - A completed SUPRA SAEINDIA Design Spec Sheet must be submitted.

S6.3.2 The SUPRA SAEINDIA Design Spec Sheet template can be found at [www.suprasaeindia.org](http://www.suprasaeindia.org). Do not alter or reformat the template prior to submission.

S6.3.3 The design judges realize that final design refinements and vehicle development may cause the submitted figures to diverge slightly from those of the completed vehicle. For

specifications that are subject to tuning, an anticipated range of values may be appropriate.

S6.3.4 The Design Report and the Design Spec Sheet, while related, are independent documents and must be submitted as two (2) separate files,

#### **S6.4 Vehicle Drawings**

S6.4.1 The Design Report must include one set of three (3) view drawings showing the vehicle, from the front, top, and side.

S6.4.2 Each drawing shall appear on a separate page. The drawings can be manual or computer generated.

S6.4.3 Photos should be placed on the optional page and will not be counted as drawings.

#### **S6.5 Design Report and Design Spec Sheet Formats**

S6.5.1 The Design Report must be submitted electronically in Adobe Acrobat® Format (\*.pdf file). This document must be a single file (text, drawings, and optional content all inclusive).

S6.5.2 The Design Report file must be named as follows:

carnumber\_schoolname.pdf using the SUPRA SAEINDIA assigned car number and the complete school name, e.g. 001\_University of SAEINDIA.pdf

S6.5.3 Design Spec Sheets must be submitted electronically in Microsoft Excel® Format (\*.xls file). The format of the Spec Sheet MUST NOT be altered.

S6.5.4 Similar to the Design Report, the Design Spec Sheet file must be named as follows: carnumber\_schoolname\_specs.xls using the SUPRA SAEINDIA assigned car number and the complete school name, e.g. 001\_University of SAEINDIA\_spec.xls

**WARNING** - Failure to exactly follow the above submission requirements may result in exclusion from the Design Event. If your files are not submitted in the required format or are not properly named then they cannot be made available to the design judges and your team will be excluded from the event.

#### **S6.6 Excess Size Design Reports**

If a team submits a Design Report that exceeds Eight (8) pages of text, Three (3) pages of drawing and one (1) optional page, then only the first eight pages of text, three pages of drawings and first optional page will be read and evaluated by the judges and team can also be penalized for the same.

#### **S6.7 Submission Deadlines**

S6.7.1 The Design Report and the Design Spec collectively constitute the "Design Documents". The Design Documents must be submitted in compliance with the specific procedure and by

the deadline shown in the website for the competition your team is entering. Submit the documents in accordance with the instruction on the individual competition websites.

S6.7.2 The Design Documents must be submitted as separate files.

S6.7.3 Document submission will be acknowledged either on the competition website or by email. Teams should have a printed copy of this acknowledgement available at the competition as proof of submission in the event of discrepancy.

### **S6.8 Penalty for Late Submission or Non-submission**

The Design Report and Design Spec Sheet collectively constitute the "Design Documents". Late submission or failure to submit all, or any one, of the Design Documents will be penalized as per rule A 8.4

### **S6.9 Penalty for Unsatisfactory Submissions**

At the discretion of the judges, teams that submit a Design Report or a Design Spec Sheet which, in the opinion of the judges does not represent a serious effort to comply with the requirements of Rules S6.2, S6.3 and S6.4 will also not compete in the design event, but may at the design judges' discretion receive between five (5) and twenty (20) points for their efforts.

### **S6.10 Design Event - Vehicle Condition**

S6.10.1 Cars must be presented for design judging in finished condition, i.e. fully assembled, complete and ready-to-run.

S6.10.2 The judges will not evaluate any car that is presented at the design event in what they consider to be an unfinished state.

S6.10.3 Unfinished cars that are refused judging will receive zero (0) points for design.

S6.10.4 Point penalties may be assessed for cars with obvious preparation issues, e.g. notably loose or missing fasteners.

**Note:** Cars can be presented for design judging without having passed technical inspection, and even if final tuning and setup is in progress.

### **S6.11 Judging Criteria**

S6.11.1 The design judges will evaluate the engineering effort based upon the team's Design Report, Design Spec Sheet, responses to questions and an inspection of the car.

S6.11.2 The design judges will inspect the car to determine if the design concepts are adequate and appropriate for the application (relative to the objectives set forth in the rules).



S6.11.3 It is the responsibility of the judges to deduct points if the team cannot adequately explain the engineering and construction of the car.

S6.11.4 Design Judging Score Sheet - The Design Judging Score Sheet is available at [www.suprasaeindia.org](http://www.suprasaeindia.org) the judges strongly urge all teams to read and study the scoresheet and all other documents related to design judging that are available on the website.

We highly recommend reading "SUPRASAEINDIA Design Judging, A Student Guide to Understanding the Process" which is available on the SUPRASAEINDIA website.

### **S6.12 Judging Sequence**

S6.12.1 The actual format of the design event may change from competition to competition and year to year as determined by the organizing body.

S6.12.2 All STUDENT FORMULA organizing bodies reserve the right to organize Design Judging into one, two or three steps at their sole discretion.

### **S6.13 Scoring**

S6.13.1 Scoring may range from 0 to 150 points at the judge's discretion.

S6.13.2 The judges may at their discretion award the highest placing team less than 150 points.

### **S6.14 Support Material**

Teams may bring with them to the Design Event any photographs, drawings, plans, charts, example components or other materials that they believe are needed to support the presentation of the vehicle and the discussion of their development process.

### **S6.15 Second year cars**

S6.15.4 Second year cars are prohibited at the SUPRASAEINDIA 2018 competitions. (See Rule A6.7)

## APPENDIX S - 1 COST MODEL AND COST METHODOLOGY

### 1 Cost Models & Costing Methodology

The cost models are the underlying methodology and equations that relate the final cost of a part to the different operations and goods used in that part. These descriptions are accurate at the time of the rules publications. The models may be expanded as necessary based on evolving requirements.

### 2 Raw materials

- 2.1 Raw materials refer to the material stocks used to produce parts from scratch, such as billet steel for machining or aluminum ingot for casting. Bar, sheet and tube stock are purchased using raw material costs. The raw material purchased must include machining allowance. Standard allowances are given in 4.1 and must be used
- 2.2 Gross weight will refer to the weight of the raw material, including all machining stock
- 2.3 Net weight will refer to the weight of the finish machined part
- 2.4 Material costs are based on part gross weight. For example a steel hub is machined from solid bar. The interior is removed by boring. The cost of the bar must include this interior material. Raw materials are normally cost by volume. A cost by weight is also given using an official density listed in the tables. Any parts that are weighed at competition to confirm cost will use the official density in calculating cost.

### 3 Assembly Labor

The assembly labor model is based on the following parameters:

- 3.1 Mass - The mass of the part influences the time it takes the operator to assemble the part to the assembly or vehicle. Light parts can be installed with one hand. Heavier parts require two hands and the heaviest parts need a lift assist apparatus. These factors are accounted for by selecting the appropriate entry from the process labor tables. The actual part mass must be equal to or less than the value selected. For example a 300g part would have an assembly labor category of 1 kg.
- 3.2 Interfaces - The more interfaces a part has with the surrounding parts the longer it takes to assemble. Parts designed for minimal constraint are the easiest and cheapest to assemble.
- 3.3 Fit type - The ease with which a part can be assembled is described by the fit. There are three categories of fits:
  - 3.3.1 Loose - the part assembles with no force. Examples include a quick release steering wheel onto the steering shaft and a bracket bolted to a monocoque.

- 3.3.2 Line on line - the part is designed to have a close fit to the surrounding parts and some build up of force is required to get the part started. Examples include a rod end inserted between two tabs in double shear and a splined axle shaft into the differential gear.
- 3.3.3 Interference - significant force is required to insert the part and mechanical assistance may be necessary. Examples include a rubber hose onto a barbed fitting and a ball bearing into a bore.

#### **4 Machining**

Costs for machining operations are based on the volume of material removed. The actual machine used, whether mill, lathe or otherwise, is the same unless a specific line item is included for that machine, such as gear hob.

Note: the machining model has been simplified from previous years. There are no longer rough and finish cuts nor near net shape processes.

- 4.1 All processes require a minimum of 1mm (0.040 inches) of machining stock to be removed from each surface of the part with machining.
- 4.7 The process multiplier for the material must also be used to calculate the total process cost of the operation. If a process multiplier is required it will be listed in the processes table in the column labeled 'Multiplier Type Used'. If the column is blank for a process none is required.
- 4.8 When costing the raw materials that go into making machined parts the machine stock must be included in the purchased material mass, even though this material is machined away to produce the final part. This represents the cost of the purchased material. For example, an upright bore is machined into a piece of billet aluminum. The interior material that is milled away must be included in the billet mass and hence cost. The same feature machined into a casting need only include 1mm of machine stock of the machined away material
- 4.9 Machining requires labor operations to account for the time it takes an operator to fixture the part onto the machine. Every machined parts requires at least a 'Machining Setup, Install and Remove' operation. This is the time it takes to pick up the work piece, fixture on the machine, and remove it when the machining is complete. For a part that requires an intermediate change in position, such as to machine the back of the part which would not be accessible in a single fixturing setup, the labor step of 'Machining Setup, Change' is also required. For example, an upright that requires three different orientations on a mill to fully machine would require two of the 'Machining Setup, Change' and the 'Machining Setup, Install and Remove' labor operations.

4.10 In certain cases, it is possible to fixture a work piece of raw material and machine more than one part out of it. For example, a self feeding lathe could machine 10 suspension inserts out of a single piece of bar stock. In this case the quantity of the 'Machining Setup, Install and Remove' may be set to 0.1. This represents the 10 parts that can be machined per setup. This assumption should clearly be noted in the Cost Report along with enough details for the Cost Judges to verify the part geometry is appropriate for the machine being used.

## 5 Tooling & Fixturing

Tooling is necessary when certain processes are used. These can be identified in the tables because the tooling required will be indicated. Sometimes several types of tooling are available for the same process. Each has a description and an associated process with which it can be used. If a process has more than one tooling type associated with it the team must use the tooling that is closest to the actual tooling used in their prototype vehicle construction. Most tooling costs are independent of part shape, the assumption being that tooling for smaller parts will be built with multiple cavities to create an optimal cost effectiveness.

5.1 After calculating the total tooling cost for a part the cost must be divided by the Production Volume Factor (PVF) before being included in the Cost Report. The PVF represents the ability of the tooling to produce parts in volume production.

### Production Volume Factor (PVF)

All parts not otherwise listed: 3000

Composite Monocoque (composite tub): 120

The following equation is used to calculate the tooling cost to be included for each part:

$$\text{Part Tooling Cost} = \frac{\text{Table Tooling Cost PVF} * \text{Number of Parts using Exact Tooling}}{\text{PVF}}$$

The tooling cost should be included with the appropriate part on the BOM. Tooling is not a separate section.

5.2 For example a cast aluminum upright uses a 2-piece sand core package. Total table price is \$5000 + \$5000 = \$10000. The team has designed the casting to be used for both the left and right hand rear corners. Calculating the Part Tooling Cost gives:

$$\text{Part Tooling Cost} = \frac{\$10000}{3000 * 2} = \$1.67 \text{ per upright}$$

The \$1.67 must be included as a line item on the Costed Bill of Material for each Upright.

5.3 Another example is a team is manufacturing a composite monocoque. The tub is constructed by building the top and bottom separately and bonding it together. Both the top and bottom use a two piece composite tool and the cost of all four tools is `45000. The PVF for tub tooling is only 120 because of the amount of time required to construct each tub so the tub Part Tooling Cost is:

$$\text{Part Tooling Cost} = \frac{\text{'45000}}{120 * 1} = \text{'375 per tub}$$

## **6 Fastener Installation**

The cost to tighten or loosen fasteners is based on the tool (or motion) needed to turn it, the diameter, length and whether the fastener requires a secondary tool for reacting the torque (such as a wrench on a nut).

- 6.1 Hand - When no tool is necessary for tightening, such as quick release fasteners or hand tightened nuts, the hand should be selected. Loose operations are those accomplished by using the fingers of the hand. If the entire hand is moving to rotate the fastener the tight category should be used.
- 6.2 Screwdriver - A tool that can be held in the hand and turned with the wrist. Any type of bit can be fitted such as straight, Philips, Torx, etc.
- 6.3 Wrench - An open-ended or box wrench or similar tool requiring motion of the hand. After a turn the wrench may have to be removed and repositioned for the next turn.
- 6.4 Ratchet - A tool with internal clutch that allows the hand to be moved and returned to the starting position without removal of the tool. Compatible with any bolt head style such as 6-point hex, 12-point hex, Torx or other.
- 6.5 Power Tool - An electric, pneumatic or other power assisted tool for running down fasteners. To qualify for power tool use a fastener must meet the following requirements:
  - 6.5.1 A socket of the size needed to drive the fastener must fit in the fully secured position
  - 6.5.2 One power tool with minimum dimensions given in Appendix S-4 must fit onto the socket.
  - 6.5.3 An extension may be used to fit the power tool but it may not exceed 0.35m in length.
- 6.6 Reaction Tool - In the case where the fastener is not being attached into the part but requires a nut or other separate threaded piece then a reaction tool will be required. This will appear as a separate line item and should appear whenever a nut is used on a bolt.

## **7 Composites**

Composite manufacture is defined by following steps:

- 7.1 Laminate - Used to build the laminate one (1) ply at a time. A ply is a single layer of the laminate consisting of a single sheet of material, regardless of material or thickness. A ply

may consist of woven carbon, unidirectional glass, adhesive film or honeycomb core, for example.

7.2 Curing Operations - Used to take a laminate and convert it to a finished composite structure. All curing operations include vacuum bagging, peel ply, breather cloth and other consumable materials and labor. Costs also include part removal from the mold.

7.2.1 Room temperature cure - used for room temperature curing resin systems.

7.2.2 Oven cure - used for higher temperature cure cycles for composites. Limited to one (1) atmosphere of external pressure.

7.2.3 Autoclave cure - used for high temperature and pressure composites curing.

7.3 Curing operations require tooling. Tooling must reflect the type of tooling actually used (composite, aluminum, steel, etc).

7.4 If hybrid weaves are used the cost can reflect the ratio of the materials in the ply. For example a 50% carbon fiber, 50% glass woven ply may use the average cost of the carbon and glass materials. If the actual fiber ratio is not used then the cost of the ply must be the cost of the highest cost material present.

7.5 When costing composite materials the total mass of the part in the Cost Report must match the actual mass of the part as presented on the vehicle for Cost Judging. The composite material, whether carbon fiber or other must be the cost of both the fiber and resin together. This is true for both prepreg and dry fiber systems and is further stated in the Materials Table. The mass of each ply can be adjusted to make the finish part mass match the Cost Report. Parts can be weighed during judging and the Cost Report mass must be equal to or greater than the actual mass of the part, even including clear coat, paint and other finishes. Note: The paint mass is being included to avoid debates in Cost Judging about how much weight the paint (or clear coat) has added. The cost of the paint and paint application need not be included if it is solely for cosmetic purposes (see S4.23.1) but the mass of paint must be included in the composite cost.

## **8 Electronics and Wiring**

The wiring harness is cost as a number of connectors of a certain style, each interconnected by a number of wires of a certain type. The electrical system is composed of three wiring types.

8.1 Signals - Inputs to the control system such as wheel speed, mass airflow or the position of a driver toggle switch.

8.2 Controls - Control system outputs. These can be digital signals, pulse width modulated or voltage outputs.

- 8.3 Power - Wires carrying current for vehicle distribution or actuators. These include vehicle power from the battery, engine starter, solenoids, motors etc.
- 8.4 Additionally, the following terms will be used for the Cost Tables:

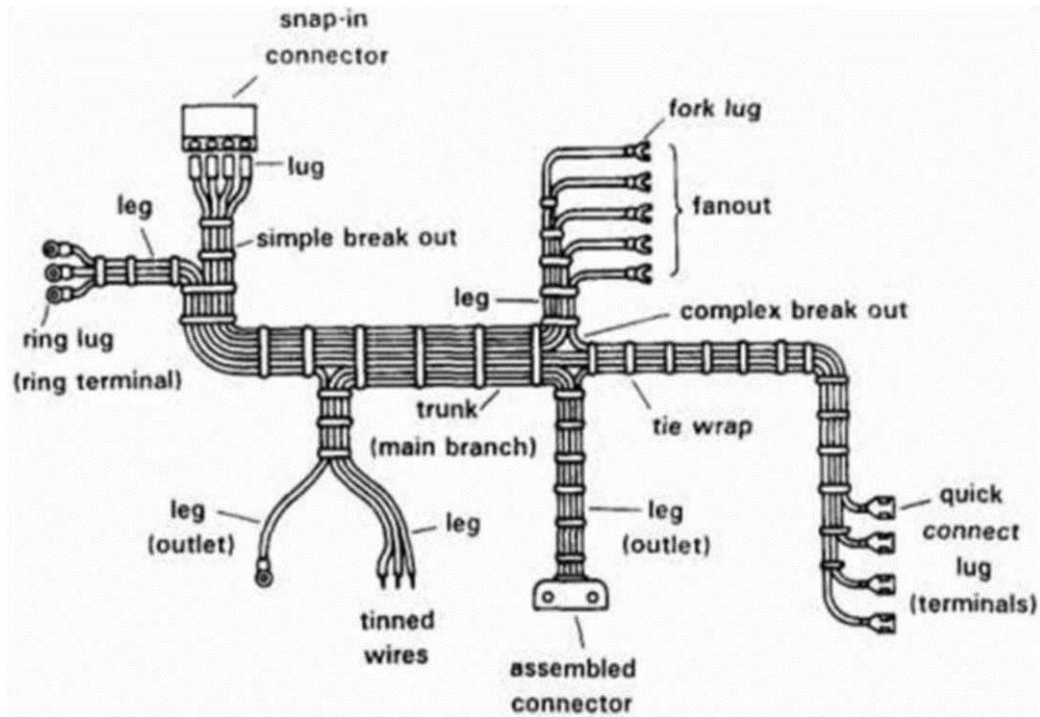

**Figure E-1.1**

From "Product Design for Manufacture & Assembly" by Geoffrey Boothroyd, 1994.

---

**APPENDIX S – 2      STANDARD PART NUMBERING**

1      All assemblies and parts in the BOM must have a part number using the following convention:

Competition Code - Date Code - Car Number - System Designation - Base Number - Suffix

1.1    Competition Code - A code for the competition entered. Refer to A2.6.

1.2    Date Code - Last two digits of the year of the event.

1.3    Car Number - A three (3) digit number assigned to the car for the specific event

1.4    System Designation - A two (2) letter code for the system under which the part is associated. These can be found in Appendix S-3.

1.5    Base Number - Five (5) digit numbers assigned at the student's discretion. For assemblies this becomes a four (4) digit number with preceding character of "A".

1.6    Suffix - Two character code showing part change history. These are provided for student use only so if desired all can be "AA".

1.6.1    First character refers to the part design revision level.

1.6.2    Second character refers to the part process revision level.

1.7    For example, a part entered into the chassis section for car number 27 competing at an event with code "SUPRASAEINDIAM" that the students have decided is part one would be:

SUPRASAEINDIAM - 08 - 027 - CH - 00001 - AA

1.8    The same part, after significant design changes would become:

SUPRASAEINDIAM - 08 - 027 - CH - 00001 - BA

The differential assembly that the students have decided is the third assembly for the Engine & Drivetrain group would be:

SUPRASAEINDIAM - 08 - 027 - EN - A0003 - AA

1.9    In the printed version of the Cost Report the competition code, date and car number fields of the part numbers do not need to be printed. They do need to be included in the digital files submitted. The event code and car numbers are for SUPRA SAEINDIA use when the different digital files are combined into the master database.

2      All fasteners in the BOM must have a part number using the same convention as parts. All fasteners use system code "FS" even though they are included in the BOM under the part and assembly where they are used.



### APPENDIX S - 3 ORGANIZED LIST OF SYSTEMS & ASSEMBLIES

The Cost Report must follow the organized list of systems and assemblies/parts outlined below. Any questions as to the correct location of the specific items **must be submitted to the rulescommittee by March 1 of the competition year.**

**The two letter abbreviation after each system name is to be used in the part number.**

<p><b>1) Brake System - BR</b>            Brake Fluid            Brake Master Cylinder            Fasteners            Brake Lines            Brake Discs            Brake Pads            Balance Bar            Calipers            Proportioning Valve</p>	<p><b>2) Engine and Drivetrain – EN</b>            Air Filter            Axles            Carburetor            Chain / Belt            Coolant            Coolant Lines            CV Joints/U Joints            Differential            Differential Bearings            Differential Mounts            Engine            Engine Mounts            Engine/Diff Oil            Exhaust Manifold            Fuel Filter            Fuel Injectors            Fuel Lines/Rails            Fuel Pressure Reg.            Fuel Pump            Fuel Tank            Fuel Vent/Check Valve            Hose Clamps            Intake Manifold            Muffler            Oil Cooler            Overflow Bottles            Radiator            Radiator Fans            Restrictor            Shields            Sprocket/Pulleys            Throttle Body            Turbo/Super Charger</p>	<p><b>3) Frame &amp; Body - FR</b>            Aerodynamic Wing (if used)            Body Attachments            Body Material            Body Processing            Clutch            Floor Pan            Frame / Frame Tubes            Mounts Integral to Frame            Pedals            Shifter            Shifter Cable/Linkage            Throttle Controls            Tube End Preps            Tubes Cuts/Bends</p>
<p><b>4) Electrical – EL</b>            Battery            Brake Light            Bulbs            Dash Panel            ECM/Engine Electronics            Fuses            Indicator Lights            Kill Switch            Oil Pressure Gage/Light            Relays            Solenoids            Starter Button            Tachometer            Water Temperature Gage            Wire Harness/Connectors</p>	<p><b>5) Miscellaneous, Finish and Assembly – MS</b>            Driver’s Harness            Fire Wall            Headrest / Restraints            Mirrors            Paint – Body            Paint – Frame            Seats            Shields</p>	
<p><b>6) Steering System – ST</b>            Steering Rack            Steering Shaft            Steering Wheel            Steering Wheel Quick Release            Tie Rods</p>	<p><b>7) Suspension System – SU</b>            Bell Cranks            Front A/Arms or Equivalent            Front Uprights            Pushrods/Pullrods            Rear A/Arms or Equivalent            Rear Uprights            Rod Ends            Shocks Front            Springs            Suspension Mechanism</p>	<p><b>8) Wheels, Wheel Bearings and Tires - WT</b>            Front Hubs            Lug Nuts            Rear Hubs            Tires            Valve Stems            Wheel Bearings            Wheel Studs            Wheel Weights            Wheels</p>





**APPENDIX S - 5 2018 SUPRASAEINDIA COST EVENT ADDENDUM**

School: \_\_\_\_\_ Car Number: \_\_\_\_\_

(Please indicate decreases using bracketed numbers.)

	Section	Original Reported Total	New Reported Total	Difference	Cost Judge Initials
1					
2					
3					
4					
5					
6					
7					
8					

TOTAL VEHICLE

Summary of differences listed above.  
fully detailed Costed Bill of Material for

INR	INR	INR
-----	-----	-----

Attach changes.

1
2
3
4
5
6
7
8

Accepted by: _____	Entered by: _____
Date: _____	Date/Time: _____

**Addendums will be accepted only at the time of registration on-site at the competition!**

These forms will then be forwarded to the cost judges the morning of the cost event.

**APPENDIX S – 6 PRESENTATION JUDGING**

**SCHOOL** \_\_\_\_\_ **CAR NUMBER** \_\_\_\_\_

Score the following categories on the basis of 0-10 points each according to the following scale (any number or fraction along this scale may be used).

- 0.0 = inadequate or no attempt
- 2.5 = attempted but below expectation
- 5 = average or expected
- 7.5 = above average but still lacking
- 10 = excellent, perfectly meets intent

\_\_\_\_\_ **CONTENT:** Were the concepts presented appropriate and adequate to explain how the car meets the intent of the customer? Were enough technical details presented without being boring?

\_\_\_\_\_ **ORGANIZATION:** Were the concepts presented in a logical order progressing from basic concept and showing how the engineering accomplished the concept? Was it clear to the audience what was to be presented and what was coming next? Were distinct introduction and overviews as well as summary and conclusions given?

\_\_\_\_\_ **VISUAL AIDS:** Were visual aids used or clear visual references made to the car? Were the illustrations visible for all of the audience?

\_\_\_\_\_ **DELIVERY:** Did the presenter speak in a clear voice? Did the presenter show enthusiasm and promote confidence in the technical aspects? Did he maintain eye contact?

\_\_\_\_\_ **QUESTIONS:** Did the answer illustrate that the team fully understood the question? Is there doubt that the team understood the answer? Did the team promote complete confidence in their response to the questions?

\_\_\_\_\_ **TOTAL = PRESENTATION POINTS (50 points maximum)**

**COMMENTS:** \_\_\_\_\_  
 \_\_\_\_\_  
 \_\_\_\_\_  
 \_\_\_\_\_  
 \_\_\_\_\_

---

## APPENDIX S - 7 DESIGN JUDGING

The Design Event Score Sheet is posted at. [www.suprasaeindia.org](http://www.suprasaeindia.org)

Teams are advised to thoroughly read all the documents related to the Design Event that are posted at [www.suprasaeindia.org](http://www.suprasaeindia.org)

---

**2018 STUDENT FORMULA RULES**

**PART D - DYNAMIC EVENT REGULATIONS**

**ARTICLE 1: DYNAMIC EVENTS AND MAXIMUM SCORES**

The maximum scores in the dynamic events are:

Acceleration	75 points
Skid Pad	50 points
Autocross	150 points
Engineering Excellence	100 points
<u>Endurance</u>	<u>300 points</u>
Total	675 points

**D1.I Vehicle Integrity and Disqualification**

D1.1.1 During the Dynamic Events, the mechanical integrity of the vehicle must be maintained.

D1.1.2 Any vehicle condition that could compromise vehicle integrity, or could compromise the track surface or could pose a potential hazard to participants, e.g. damaged suspension, brakes or steering components, fluid leaks, dragging bodywork, or lost or loose body panels, will be a valid reason for exclusion by the official until the problem is rectified.

Note: If this happens during the Endurance Event, it means disqualification from the heat.

**ARTICLE 2: WEATHER CONDITIONS**

The organizer reserves the right to alter the conduct and scoring of the competition based on weather conditions.

**ARTICLE 3: RUNNING IN RAIN**

**D3.I Operating Conditions**

The following operating conditions will be recognized at STUDENT FORMULA:

D3.1.1 Dry - Overall the track surface is dry.

D3.1.2 Damp - Significant sections of the track surface are damp.

D3.1.3 Wet - The entire track surface is wet and there may be puddles of water.

D3.1.4 Weather Delay/Cancellation - Any situation in which all, or part, of an event is delayed, rescheduled or canceled in response to weather conditions.

**D3.2 Decision on Operating Conditions**

The operating condition in effect at any time during the competition will be decided by the competition officials.

### **D3.3 Notification**

If the competition officials declare the track(s) to be "Damp" or "Wet",

- i. This decision will be announced over the public address system, and
- ii. A sign with either "Damp" or "Wet" will be prominently displayed at both the starting line(s) or the start-finish line of the event(s), and the entry gate to the "hot" area.

### **D3.4 Tire Requirements**

The operating conditions will determine the type of tires a car may run as follows:

D3.4.1 Dry - Cars must run their Dry Tires, except as covered in Rule D3.8.2.

D3.4.2 Damp - Cars may run either their Dry Tires or Rain Tires, at each team's option.

D3.4.3 Wet - Cars must run their Rain Tires.

### **D3.5 Event Rules**

All event rules remain in effect.

### **D3.6 Penalties**

All penalties remain in effect.

### **D3.7 Scoring**

No adjustments will be made to teams' times for running in "Damp" or "Wet" conditions. The minimum performance levels to score points may be adjusted if deemed appropriate by the officials.

### **D3.8 Tire Changing**

D3.8.1 During the Acceleration, Skid-Pad or Autocross Events:

Within the provisions of Rule D3.4 above, teams may change from Dry Tires to Rain Tires or vice versa at any time during those events at their own discretion.

D3.8.2 During the Endurance Event:

Teams may change from Dry to Rain Tires or vice versa at any time while their car is in the staging area inside the "hot" area.

All tire changes after a car has received the "green flag" to start the Endurance Event shall take place in the Driver Change Area.

(a) If the track was "Dry" and is declared "Damp":

- Teams may start on either Dry or Rain Tires at their option.
- Teams that are on the track when it is declared "Damp", may elect, at their option, to pit in the Driver Change Area and change to Rain Tires under the terms spelled out below in "Tire Changes in the Driver Change Area".

(b) If the track is declared "Wet":

- A Red Flag will be shown at the Start/Finish Line and all cars will enter the Driver Change Area.
  - Those cars that are already fitted with "Rain" tires will be allowed re-start without delay subject to the discretion of the Event Captain/Chief Marshall.
  - Those cars without "Rain" tires will be required to fit them under the terms spelled out below in "Tire Changes in the Driver Change Area". They will then be allowed to re-start at the discretion of the Event Captain/Chief Marshall.
- (c) If the track is declared "Dry" after being "Damp" or "Wet":
- The teams will NOT be required to change back to "Dry" tires.
- (d) Tire Changes at Team's Option:
- Within the provisions of Rule D3.4 above and Rule D3.8.2 (b) above, a team will be permitted to change tires at their option.
  - If a team elects to change from "Dry" to "Rain" tires, the time to make the change will NOT be included in the team's total time.
  - If a team elects to change from "Rain" tires back to "Dry" tires, the time taken to make the change WILL be included in the team's total time for the event, i.e. it will not be subtracted from the total elapsed time. However, a change from "Rain" tires back to "Dry" tires will not be permitted during the driver change.
  - To make such a change, the following procedure must be followed:
    - Team makes the decision,
    - Team has tires and equipment ready near Driver Change Area,
    - The team informs the Event Captain/Chief Marshall they wish their car to be brought in for a tire change,
    - Officials inform the driver by means of a sign or flag at the checker flag station,
    - Driver exits the track and enters the Driver Change Area in the normal manner.
- e Tire Changes in the Driver Change Area:
- Per Rule D8.12, no more than three people for each team may be present in the Driver Change Area during any tire change, e.g. a driver and two crew or two drivers and one crew member.
  - No other work may be performed on the cars during a tire change.
  - Teams changing from "Dry" to "Rain" tires will be allowed a maximum of ten (10) minutes to make the change.
  - If a team elects to change from "Dry" to "Rain" tires during their scheduled driver change, they may do so, and the total allowed time in the Driver Change Area will be thirteen (13) minutes.
  - The time spent in the driver change area of less than 10 minutes without driver change, or 13 minutes with driver change, will not be counted in the team's total time for the event. Any time in excess of these times will be counted in the team's total time for the event.



---

#### **ARTICLE 4: DRIVER LIMITATIONS**

**D4.1 Restriction on Professional Drivers** - The Committee has prohibited individuals (Drivers) who have been paid to drive in a race car and or anyone who has finished in the top 5 in any national racing, from driving in STUDENT FORMULA dynamic events.

#### **ARTICLE 5: ACCELERATION EVENT**

##### **D5.1 Acceleration Objective**

The acceleration event evaluates the car's acceleration in a straight line on flat pavement.

##### **D5.2 Acceleration Procedure**

Course Layout - The acceleration course length will be 75 m (82 yards) from starting line to finish line. The course will be at least 4.9 m (16 ft) wide as measured between the inner edges of the bases of the course edge cones. Cones are placed along the course edges at intervals of about 5 paces (roughly 20 feet). Cone locations are not marked on the pavement.

D5.2.1 Staging - The foremost part of the car will be staged at 0.30 m (11.8 inches) behind the starting line. Cars will accelerate from a standing start.

D5.2.2 Starting - A green flag will be used to indicate the approval to begin, however, timing starts only when the vehicle crosses the starting line as measured by the timing system.

D5.2.3 Second Run Option - A driver has the option to make a second run immediately after his/her first run.

##### **D5.3 Acceleration Heats ( There will not be Heats in Student Formula Event )**

D5.3.2 Starting order will be based upon time of arrival to the staging area.

##### **D5.4 Tire Traction - Limitations**

Special agents that increase traction may not be added to the tires or track surface and "burnouts" are not allowed.

##### **D5.5 Acceleration Scoring**

The acceleration score is based upon the corrected elapsed time. Elapsed time will be measured from the time the car crosses the starting line until it crosses the finish line.

## **D5.6 Acceleration Penalties**

### **D5.6.1 Cones Down or Out (DOO)**

A two (2) second penalty will be added for each DOO (including entry and exit gate cones) that occurred on that particular run to give the corrected elapsed time.

### **D5.6.2 Off Course**

An Off Course (OC) will result in a DNF for that run.

## **D5.7 Did Not Attempt**

Cars that have not run by the end of the event (determined by the organizer) will receive a Did Not Finish (DNF).

## **D5.8 Acceleration Scoring Formula**

D5.8.1 The score for the acceleration event is spread between zero (0) and seventy-five (75) based upon the elapsed time.

D5.8.2 The following equation is used to determine the scores for the event:

$$\text{ACCELERATION SCORE} = (71.5 \times (T_{\text{max}}/T_{\text{your}}) - 1) / ((T_{\text{max}}/T_{\text{min}}) - 1) + 3.5$$

Where:

**T<sub>your</sub>** is the best corrected elapsed time for the team including penalties. **T<sub>min</sub>** is the elapsed time of the fastest car.

**T<sub>max</sub>** is 150% of **T<sub>min</sub>**

D5.8.3 In the above equation, the first term on the right hand side is "performance" points", while the second term represents "completion points," or the minimum score for having successfully completed the event.

DNF = zero (0) points

## **ARTICLE 6: SKID-PAD EVENT**

### **D6.1 Skid-Pad Objective**

The objective of the skid-pad event is to measure the car's cornering ability on a flat surface while making a constant-radius turn.

### **D6.2 Skid-Pad Heats ( There will not be Heats in Student Formula Event )**

### **D6.4 Skid-Pad Layout**

There will be two (2) pairs of concentric circles in a figure of eight pattern. The centers of these circles will be 18.25 m (59.88 feet) apart. The inner circles will be 15.25 m (50.03 feet) in diameter, and the outer circles will be 21.25 m (69.72 feet) in diameter. The driving path will be the 3.0 m (9.84 feet) path between the inner and outer circles. The cars will

enter and exit through gates on a 3.0 m wide path that is tangential to the circles where they meet.

The line between the centers of the circles defines the start/stop line. A lap is defined as traveling around one (1) of the circles from the start/stop line and returning to the start/stop line.

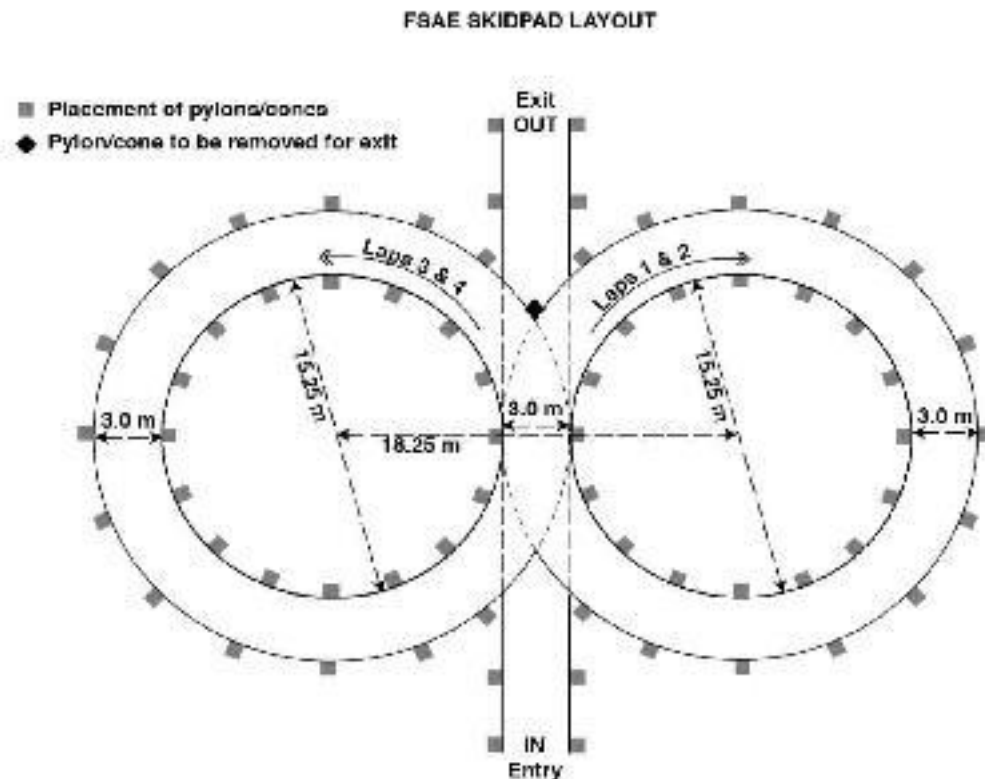

## D6.5 Skid-Pad Layout - Marking

D6.5.1 Sixteen (16) pylons will be placed around the inside of each inner circle thirteen (13) pylons positioned around the outside of each outer circle in the pattern shown in the SUPRASAEINDIA skid pad layout diagram.

D6.5.2 Each circle will be marked with a chalk line, inside the inner circle and outside the outer circle, i.e. not on the driving path.

D6.5.3 Additional pylons will establish the required entry and exit gates. Also, a cone will be placed in the middle of the exit gate to prevent unintended exits until the finish lap.

Note: The diagram in section D6.4 shows the circles for cone placement, not for course marking. Chalk lines are marked on the opposite side of the cones, i.e. not in the driving path.

## D6.6 Skid-Pad Procedure

The cars will enter perpendicular to the figure eight and will take one full lap on the right circle to establish the turn. The next lap will be on the right circle and will be timed. Immediately following the second lap, the car will enter the left circle for the third lap. The fourth lap will be on the left circle and will be timed. Immediately upon finishing the fourth lap, the car will exit the track. The car will exit at the intersection moving in the same direction as entered. A driver has the option to take a second run immediately after the first.

## D6.7 Skid-Pad Penalties

The elapsed time for the right and left circle will be averaged together after the following penalties have been assessed.

### D6.7.1 Cones Down Or Out (DOO)

A penalty of 0.25 seconds will be added to the time for every cone that is knocked "down or out" (including gate cones).

### D6.7.2 Off Course

Cars that spin-out can continue as long as they have not gone off course. Cars going off course will be classified as DNF.

### D6.7.3 Incorrect Laps

Cars that do not follow D6.6 above, i.e. run an incorrect number of laps or run the laps in the wrong sequence will be classified as DNF.

## D6.8 Skid-Pad Scoring

D6.8.1 The skid-pad score is computed based upon the lateral acceleration capability. Lateral acceleration (typically referred to as G's) is computed from  $2.012 \text{ diameter}/t^2$ . A diameter of 17.10 m will be assumed in computing lateral G's.

D6.8.2 If there are two separate skid-pad locations, then the score will be based on the best run from either skid-pad.

D6.8.3 The following equation is used to determine the scores for the skid-pad event:

$$\text{SKID PAD SCORE} = (47.5 \times (T_{\text{max}}/T_{\text{your}})^2 - 1) / ((T_{\text{max}}/T_{\text{min}})^2 - 1) + 2.5$$

Where:

**T<sub>your</sub>** is the average of the left and the right timed laps on your best run including penalties.

**T<sub>min</sub>** is the elapsed time of the fastest car  
**T<sub>max</sub>** is 125% of T<sub>min</sub>

D6.8.4 The first term on the right-hand side of the equation represent "performance points," while the second term represents "completion points," or the minimum score for having successfully completed the event.

D6.8.5 Negative "performance" points will not be given. However, 2.5 points will be given for a car that completes a run, even if T<sub>your</sub> exceeds 125% of the fastest time (T<sub>min</sub>).

## ARTICLE 7: AUTOCROSS EVENT

### D7.1 Autocross Objective

The objective of the autocross event is to evaluate the car's maneuverability and handling qualities on a tight course without the hindrance of competing cars. The autocross course will combine the performance features of acceleration, braking, and cornering into one event.

### D7.2 Autocross Course Specifications & Speeds

D7.2.1 The following standard specifications will suggest the maximum speeds that will be encountered on the course. Average speeds should be 40 km/hr (25 mph) to 48 km/hr (30 mph).

Note: the actual average speed for any track will depend on the prevailing conditions and the area available to the organizers in which the track is setup, therefore the quoted speeds are intended as a rough guide only.

**Straights:** No longer than 60 m (200 feet) with hairpins at both ends (or) no longer than 45 m (150 feet) with wide turns on the ends.

**Constant Turns:** 23 m (75 feet) to 45 m (148 feet) diameter.

**Hairpin Turns:** Minimum of 9 m (29.5 feet) outside diameter (of the turn).

**Slaloms:** Cones in a straight line with 7.62 m (25 feet) to 12.19 m (40 feet) spacing.

**Miscellaneous:** Chicanes, multiple turns, decreasing radius turns, etc. The minimum trackwidth will be 3.5 m (11.5 feet).

D7.2.2 The length of each run will be approximately 0.805 km (1/2 mile) and the driver will complete a specified number of runs.

D7.2.3 The organizers reserve the right to run the Autocross Event on courses of different length.

D7.2.4 The organizers reserve the right to deviate from the parameters specified in this rule, D7.2, when they determine it is appropriate given the characteristics of a particular competition site.

### D7.3 Autocross Procedure ( There will not be Heats in Student Formula Event )

*D7.3.2 Starting order will be based upon time of arrival to the staging area.*

D7.3.4 The car will be staged such that the front wheels are 6 m (19.7 feet) behind the starting line. The timer starts only after the car crosses the start line.

#### **D7.4 Autocross Penalties**

The cars are judged on elapsed time plus penalties. The following penalties will be added to the elapsed time:

##### **D7.4.1 Cone Down or Out (DOO)**

Two (2) seconds per cone, including any after the finish line.

##### **D7.4.2 Off Course (OC)**

- a. An "off course" occurs when the vehicle has all four (4) wheels outside the course boundary as indicated by (a) cones, (b) edge marking or (c) the edge of the paved surface. Where more than one boundary indicator is used on the same course, at any given point the narrowest track will be used when determining off course penalties.
- b. When an OC occurs, the driver must reenter the track at or prior to the point of exit or a twenty (20) second penalty will be assessed.
- c. Two (2) wheels off will not incur an immediate penalty. However, repeated driving of this type is cause for a black flag. .
- d. Penalties will not be assessed for accident avoidance or other reasons deemed sufficient by the track officials.

##### **D7.4.3 Missed Slalom**

Missing one or more gates of a given slalom will be counted as one "off-course" per occurrence. Each occurrence will incur a twenty (20) second penalty.

#### **D7.5 Stalled & Disabled Vehicles**

D7.5.1 If a car stalls and cannot restart without external assistance, the car will be deemed disabled.

D7.5.2 Disabled cars are scored DNF for that attempt.

D7.5.3 Disabled cars will be cleared from the track by the track workers. At the direction of the track officials team members may be instructed to retrieve the vehicle. Vehicle recovery may only be done under the control of the track officials.

#### **D7.6 Corrected Elapsed Time**

D7.6.1 The elapsed time plus any penalties from that specific run will be used as the corrected elapsed time.

D7.6.2 Cars that are unable to complete the course with an average speed of 80% of the fastest car will not be awarded "performance" points. This means that any autocross time in excess of 125% of the fastest time will receive no "performance" points.

**D7.7 Best Run Scored**

The time required to complete each run will be recorded and the team's best corrected elapsed time will be used to determine the score.

**D7.8 Autocross Scoring Formula**

D7.8.1 The following equation is used to determine the autocross score:

$$\text{AUTOCROSS SCORE} = 142.5 \times \frac{\left(\frac{T_{\text{max}}}{T_{\text{your}}}\right) - 1}{\left(\frac{T_{\text{max}}}{T_{\text{Min}}}\right) - 1} + 7.5$$

Where:

**T<sub>min</sub>** is the lowest elapsed time recorded for any competitor in either corrected heat

**T<sub>max</sub>** is 145% of T<sub>min</sub>

**T<sub>your</sub>** is the lowest corrected elapsed time in either heat for the team being scored.

D7.8.2 In the equation above, the first term on the right hand side represents "performance" points, while the second term, or "completion" points represents the minimum score for having successfully completed the event.

D7.8.3 Negative "performance" points will not be given. However, 7.5 points will be given for a car that completes a run, even if T<sub>your</sub> exceeds 145% of the fastest time (T<sub>min</sub>)

**ARTICLE 8: ENDURANCE**

**D8.1** At STUDENT FORMULA competitions the Endurance will consist of a single heat. For competitions outside INDIA please check the event website.

**D8.2 Engineering Excellence**

Fuel efficiency changed to engineering excellence score.

**D8.3 Right to Change Procedure**

This Article, D8, contains the general guidelines for conducting the Endurance event, however, the organizers reserve the right to establish procedures specific to the conduct of the event at each competition site. All such procedures will be made known to the teams through email or the specific STUDENT FORMULA competition news page website.

**D8.4 Endurance Objective—300 points**

The Endurance Event is designed to evaluate the overall performance of the car and to test the car's durability and reliability.

### **D8.5 Engineering Excellence—100 points**

Engineering excellence score will be based on the combined performance of teams in static (Design Evaluation) and dynamic events (Acceleration, Autocross) along with some good engineering practices like lesser weight of the vehicle and performance during the main event (Lesser time to clear TI and lesser usage of hot pits) will be considered.

### **D8.6 Endurance Course Specifications & Speeds**

D8.6.1 Course speeds can be estimated by the following standard course specifications. Average speed should be 48 km/hr (29.8 mph) to 57 km/hr (35.4 mph) with top speeds of approximately 105 km/hr (65.2 mph).

Note: the actual average speed for any track will depend on the prevailing conditions and the area available to the organizers in which the track is setup, therefore the quoted speeds are intended as a rough guide only.

D8.6.2 The standard specifications for the SUPRASAEINDIA Endurance Course are:

**Straights:** No longer than 77.0 m (252.6 feet) with hairpins at both ends (or) no longer than 61.0 m (200.1 feet) with wide turns on the ends. There will be passing zones at several locations.

**Constant Turns:** 30.0 m (98.4 feet) to 54.0 m (177.2 feet) diameter.

**Hairpin Turns:** Minimum of 9.0 m (29.5 feet) outside diameter (of the turn).

**Slaloms:** Cones in a straight line with 9.0 m (29.5 feet) to 15.0 m (49.2 feet) spacing.

**Miscellaneous:** Chicanes, multiple turns, decreasing radius turns, etc. The standard minimum track width is 4.5 m (14.76 feet).

D8.6.3 The organizers reserve the right to deviate from the parameters specified in this rule, D8.6, when they determine it is appropriate given the characteristics of the particular competition site.

### **D8.7 Endurance General Procedure**

D8.7.1 The event will be run as a single heat approximately 22 km (13.66 miles) long.

D8.7.2 Teams are not allowed to work on their vehicles during the heat.

D8.7.3 A driver change must be made during a three (3) minute period at the midpoint of the heat.

D8.7.4 Wheel-to-wheel racing is prohibited.

D8.7.5 Vehicles must not be driven in reverse



D8.7.6 Passing another vehicle may only be done in an established passing zone or under control of a course marshal.

D8.7.7 Elapsed time will begin when Driver A enters the course and crosses the timing line.

### **D8.8 Endurance Run Order**

D8.8.2 The run order for endurance will typically be derived from the finish order for the autocross event.

The organizer has the option to order the cars from fastest to slowest or from slowest to fastest and to designate groups, e.g. design finalists, ordered for other purposes.

Teams without an autocross score, the finish order for the acceleration event may be substituted. For teams without a score in either autocross or acceleration, the finish order for skid pad may be substituted. Teams without a score in the event used to determine the run order may run at the end of the heat.

D8.8.3 Based on the results of all dynamic events, and considering the operating conditions under which they were run, the endurance event captain may, at his sole discretion, move teams to different positions within the starting order.

D8.8.4 Teams are required to keep track of the run order and have their cars fueled, in line and prepared to start when their turn to run arrives.

D8.8.5 Teams that are not ready-to-run when their turn arrives will be penalized two (2) minutes and permitted to run at the end of the heat (time permitting) or at the discretion of the event captain.

### **D8.9 Endurance Fuel Fill - IC cars**

Before entering the event each vehicle's fuel tank must be filled to the fuel level line (see Rule IC2.6.6, "Fuel Level Line") at the fueling station. During fueling, once filled to the scribe line, no shaking or tilting of the tank or fuel system (incl. entire vehicle) is allowed.

### **D8.11 Endurance Vehicle Starting/ Restarting**

D8.11.1 The vehicle must be capable of starting / restarting without external assistance at all times once the vehicle has begun the heat.

D8.11.2 If a vehicle stalls out on the track, it will be allowed one (1) lap by the car that is following it (approximately one (1) minute) to restart.

D8.11.3 If a vehicle has a restart problem at the end of Driver Change, it will be allowed a further two (2) minutes to restart the engine.

D8.11.4 If restarts are not accomplished within the above times, the car will be deemed disabled and scored DNF for the heat.

## **D8.12 Endurance Driver Change Procedure**

D8.12.1 Three (3) minutes are allowed for the team to change drivers.

D8.12.2 Only three (3) team members, including the driver or drivers, will be allowed in the driver change area, and only the tools necessary adjust the car to accommodate the second driver and/or change tires will be carried into this area (no tool chests etc.). Extra people entering the driver change area will result in a twenty point (20 pt) penalty to the final endurance score for each extra person entering the area.

D8.12.4 Other than changes to accommodate the second driver or covered by D3.8.2 "*Tire Changing*" and turning on and off the car with the master switch(es), the team is not permitted to perform any work on the car during Driver Change.

D8.12.5 Driver A will drive for 11 km (6.83 miles), and then be signaled into the driver change area.

D8.12.6 Driver A will exit the vehicle and any necessary adjustments will be made to the vehicle to fit Driver B (seat cushions, head restraint, pedal position, etc.). Driver B will then be secured in the vehicle.

D8.12.7 Driver B will drive for 11 km (6.83 miles) and elapsed time will stop when the car completes the total 22 km (13.66 miles) distance.

D8.12.8 Driver B will proceed directly to the fueling station. The tank will be filled to refill mark and the amount will be recorded

D8.12.10 The driver change area will be placed such that the timing system will see the driver change as an extra long lap. Unless this driver change takes longer than three (3) minutes, this extra long lap will not count. If the driver change takes longer than three minutes, the extra time will be counted into the final time.

## **D8.13 Entering the Track**

D8.13.1 Cars will be allowed to enter the track based upon the level of traffic on the course.

D8.13.2 The number of vehicles simultaneously on the course depends on the track length and design as well as the operating conditions. In dry conditions, there are typically 5 to 7 vehicles allowed per kilometer of track. This includes cars in the driver change area.

D8.13.3 Because repairs are not allowed during the heat, and there will be no refueling during the heat, there will not be a restart queue of any kind.

## **D8.14 Breakdowns & Stalls**

D8.14.1 If a vehicle breaks down it will be removed from the course and will not be allowed to re-enter the course.

D8.14.2 If a vehicle stalls, or ingests a cone, etc., it will be allowed to restart (See D8.10 "Endurance Vehicle Starting/Restarting") and re-enter the course where it went off, but no work may be performed on the vehicle.

D8.14.3 If a car stalls and cannot be restarted without external assistance, the track workers will push the car clear of the track. At the discretion of event officials, two (2) team members may retrieve the car under direction of the track workers.

Comment - Teams are reminded that although course crews exercise due care, the organizers are not responsible for any damage that may occur when moving a disabled vehicle. Please consider the comment to Rule T6.6 "Jacking Point".

### **D8.15 Endurance Minimum Speed Requirement**

D8.15.1 If a car is unable to maintain lap times within one hundred forty five percent (145%) of the fastest lap time for the course, then it must exit immediately.

D8.15.2 Disqualification for failure to maintain the minimum speed will be made at the discretion of the Chief Marshall/Director of Operations.

### **D8.16 Post Event Refueling**

Vehicles must power down after leaving the course and be pushed to the fueling area for IC cars

FOR IC cars, Fuel pumps will be turned on and fuel valves will be opened to insure complete refueling.

### **D8.17 Endurance Lap Timing**

Each lap of the endurance event will be individually timed either by electronic means, or by hand. The time for an individual heat will be determined by subtracting the extra long lap for the driver change, and the time taken for any stops under a mechanical black flag, from the total time and adding any penalty points.

### **D8.18 Endurance Penalties**

D8.18.1 Penalties will not be assessed for accident avoidance or other reason deemed sufficient by the track official.

D8.18.2 The penalties in effect during the Endurance Event are listed below.

D8.18.3 Cones

Cone down or out (DOO) - two (2) seconds per cone. This includes cones before the start line and after the finish line.

D8.18.4 Off Course (OC)

a. An "off course" occurs when the vehicle has all four (4) wheels outside the course boundary as indicated by (a) cones, (b) edge marking or (c) the edge of the paved

surface. Where more than one boundary indicator is used on the same course, at any given point the narrowest track will be used when determining off course penalties.

- b. When an OC occurs, the driver must reenter the track at or prior to the point of exit or a twenty (20) second penalty will be assessed.
- c. Two (2) wheels off will not incur an immediate penalty. However, repeated driving of this type is cause for a black flag. .

#### D8.18.5 Missed Slalom

Missing one or more gates of a given slalom will incur a twenty (20) second penalty.

#### D8.18.6 Penalties for Moving Violations

The following are penalties and assessed times or disqualifications for moving violations:

- a. Failure to obey a flag: 1 minute
- b. Over Driving (After a closed black flag): 1 Minute
- c. Vehicle to Vehicle contact: 2 Minutes up to disqualification depending on the nature of the incident.

#### D8.18.7 Out of Order

Running out of order - two (2) minute penalty.

#### D8.18.8 Mechanical Problem

No time penalty. The time taken for mechanical inspection under a "mechanical black flag" is considered officials' time and is not included in the teams' total time. However, if the inspection reveals a mechanical integrity problem the vehicle may be disqualified under Rule D 1.1 "Vehicle Integrity and Disqualification".

#### D8.18.9 Reckless or Aggressive Driving

Any reckless or aggressive driving behavior (such as forcing another car off the track, refusal to allow passing, or close driving that would cause the likelihood of car contact) will result in a black flag for that driver. When a driver receives a black flag signal, he must proceed to the penalty box to listen to a reprimand for his driving behavior. The amount of time spent in the penalty box will vary from one (1) to four (4) minutes depending upon the severity of the offense.

If it is impossible to impose a penalty by a stop under a black flag, e.g. not enough laps left, the event officials may add an appropriate time penalty to the team's elapsed time.

#### D8.18.10 Vehicle Control Issues

The Chief Marshall/Director of Operations may disqualify a vehicle if, for any reason including driver inexperience and mechanical problems, it is too slow or being driven in a manner that, in the sole opinion of the event officials demonstrates an inability to properly control the car. Disqualification for a vehicle control issue is scored as DNF.

### **D8.19 Endurance Scoring**

D8.19.1 The score for the Endurance Event is the sum of the Endurance Time Score and the Endurance Finish Score.

D8.19.2 The Endurance Time Score is based on the team's time for the event, including penalties, compared to the fastest team.

D8.19.3 A car will also receive an Endurance Finish Score of fifty (50) points if the team's time for the event, including penalties, is less than or equal to the maximum allotted time.

D8.19.4 Endurance time will only be calculated if team complete the full endurance race

### **D8.20 Endurance Scoring Formula**

D8.20.1 The times for the endurance event will be based upon the sum of the times of each driver in the heat plus penalties.

D8.20.2 The following equation is used to determine the time scores for the event:

If **T<sub>your</sub>** is < or = to **T<sub>max</sub>**:

$$\text{ENDURANCE SCORE} = 250 \times \frac{(T_{\text{max}}/ T_{\text{your}})^{-1}}{(T_{\text{max}}/ T_{\text{min}})^{-1}} + 50$$

If  $T_{your} > T_{max}$ : ENDURANCE SCORE = 0 (ZERO)

$T_{min}$  will be the lowest corrected time of the fastest team of the event.

$T_{your}$  will be the combined corrected times of both of your team's drivers in the heat.

$T_{max}$  will be 1.45 times  $T_{min}$ .

If ENDURANCE SCORE  $< Laps\ Comp$ , then ENDURANCE SCORE =  $Laps\ Comp$

$Laps\ Comp$  is the number of full laps completed by the team.

D8.20.3 If, in the opinion of the officials, course conditions change significantly during the running of the event then they may, at their sole discretion, set  $T_{max}$  to a higher value.

### **Engineering Excellence**

It is to judge the overall engineering skills of the teams to design, fabricate and validate the vehicle along with performance during the main event.

**Engineering Excellence Scoring** Engineering excellence score will be based on the combined performance of teams in static (Design Evaluation) and dynamic events (Acceleration, Autocross) along with some good engineering practices like lesser weight of the vehicle and performance during the main event (Lesser time to clear TI and lesser usage of hot pits) will be considered.

**Engineering Excellence Score** =  $0.15 * TI\ Score + 0.12 * Acceleration\ score + 0.12 * Auto\ cross\ Score + 0.12 * Design\ Score + 0.2 * Weight\ Score + 0.16 * Endurance\ Score + 0.1 * Hot\ Pit\ Access\ Score$

TI Score = 100 (Directly not in overall score, Only to calculate Engineering Excellence Score)

Teams cleared the TI first will get maximum score and other teams will get relative scoring

Weight Score = 100 (Directly not in overall score, Only to calculate Engineering Excellence Score)

Team with least weight will get maximum score and other teams will get relative scoring

Hot Pit Score = 100 (Directly not in overall score, Only to calculate Engineering Excellence Score)

Teams using the hot pit for least number of time during the entire main event will get maximum marks and other teams will get relative score

**Teams getting zero in any of the individual score used for engineering excellence will get zero score for engineering excellence irrespective of performance in other events.**

### **D8.25 Post Event Engine Check**

The organizer reserves the right to impound any vehicle immediately after the event to check engine displacement (method to be determined by the organizer) and restrictor size.

### **D8.26 Endurance Event - Driving**

D8.26.1 During Endurance when multiple cars are running on the course it is paramount that the drivers strictly follow all of the rules and driving requirements.

D8.26.2 Aggressive driving, failing to obey signals, not yielding for passing, etc will result in a black flag and a discussion in the penalty box with course officials. The amount of time spent in

the penalty box is at the discretion of the officials and is included in the run time. Penalty box time serves as a reprimand as well as informing the driver of what he/she did wrong. Drivers should be aware that contact between open wheel vehicles is especially dangerous because tires touching can throw one car into the air.

Endurance is a timed event in which drivers compete only against the clock not against other cars. Aggressive driving is unnecessary.

### **D8.27 Endurance Event - Passing**

D8.27.1 Passing during Endurance may only be done in the designated passing zones and under the control of the track officials.

D8.27.2 Passing zones have two parallel lanes - a slow lane for the cars that are being passed and a fast lane for the cars that are making a pass. On approaching a passing zone a slower leading car will be blue flagged and must shift into the slow lane and decelerate. The following faster car will continue in the fast lane and make the pass. The car that had been passed may reenter traffic only under the control of the passing zone exit flagman.

D8.27.3 Passing, i.e. slow, lanes may be either to the left or right of the fast lane depending on the design of the specific course.

D8.27.4 These passing rules do not apply to cars that are passing disabled cars on the course or cars that have spun out and are not moving. When passing a disabled or off-track car it is critical to slow down, drive cautiously and be aware of all the vehicles and track workers in the area.

---

D8.27.5 Under normal driving conditions when not being passed all cars use the fast lane.

### **D8.28 Endurance Event - Driver's Course Walk**

The endurance course will be available for walk by drivers prior to the event. All endurance drivers are required to walk the course before the event starts.

## **ARTICLE 9: FLAGS**

### **D9.1 Flag Effect**

Flag signals are commands that must be obeyed immediately and without question.

### **D9.2 Flag Types**

There are two kinds of flags for the competition: Command flags and Informational flags.

D9.2.1 Command flags are just that, flags that send a message to the competitor that the competitor must obey without question.

D9.2.2 Informational flags, on the other hand, require no action from the driver, but should be used as added information to help him or her to maximize performance.

### **D9.3 Command Flags**

The following is a brief description of the flags used at the competitions in North America and what each flag means.

**Note:** Not all of these flags are used at all competitions and some alternate designs are occasionally displayed. Any variations from this list will be explained at the drivers meetings.

D9.3.1 **BLACK FLAG**-Pull into the penalty box for discussion with the Chief Marshall/Director of Operations or other official concerning an incident. A time penalty may be assessed for such incident.



D9.3.2 **BLACK FLAG WITH ORANGE DOT** - Pull into the penalty box for a mechanical inspection of your car, something has been observed that needs closer inspection.





D9.3.3 BLUE FLAG - Pull into the designated passing zone to be passed by a faster competitor. Obey the corner workers hand signals at the end of the passing zone to merge into competition.



D9.3.4 CHECKER FLAG - Your session has been completed. Exit the course at the first opportunity.



D9.3.5 GREEN FLAG - Your session has started, enter the course under direction of the starter. (NOTE: If you stall the vehicle, please restart and await another green flag as the opening in traffic may have closed.)



D9.3.6 RED FLAG - Come to an immediate safe controlled stop on the course. Pull to the side of the course as much as possible to keep the course open. Follow corner worker directions.



D9.3.7 YELLOW FLAG (Stationary) - Danger, SLOW DOWN, be prepared to take evasive action, something has happened beyond the flag station. NO PASSING unless directed by the corner workers.



D9.3.8 YELLOW FLAG (Waved) - Great Danger, SLOW DOWN, evasive action is most likely required, BE PREPARED TO STOP, something has happened beyond the flag station, NO PASSING unless directed by the corner workers.

#### **D9.4 Informational Flags**

D9.4.1 RED AND YELLOW STRIPED FLAG - Something is on the racing surface that should not be there. Be prepared for evasive maneuvers to avoid the situation. (Corner workers may be able to point out what and where it is located, but do not expect it.)



D9.4.2 WHITE FLAG - There is a slow moving vehicle on the course that is much slower than you are. Be prepared to approach it at a cautious rate.



#### **ARTICLE 10: RULES OF CONDUCT**

##### **D10.1 Competition Objective - A Reminder**

The STUDENT FORMULA is a design engineering competition that requires performance demonstration of vehicles and is NOT a race. Engineering ethics will apply. It is recognized that hundreds of hours of labor have gone into fielding an entry into STUDENT FORMULA. It is also recognized that this event is an "engineering educational experience" but that it often times becomes confused with a high stakes race. In the heat of competition, emotions peak and disputes arise. Our officials are trained volunteers and maximum human effort will be made to settle problems in an equitable, professional manner.

##### **D10.2 Unsportsmanlike Conduct**

In the event of unsportsmanlike conduct, the team will receive a warning from an official. A second violation will result in expulsion of the team from the competition.

##### **D10.3 Official Instructions**

Failure of a team member to follow an instruction or command directed specifically to that team or team member will result in a twenty five (25) point penalty.

**Note:** This penalty can be individually applied to all members of a team.

##### **D10.4 Arguments with Officials**

Argument with, or disobedience to, any official may result in the team being eliminated from the competition. All members of the team may be immediately escorted from the grounds.

### **D10.5 Alcohol and Illegal Material**

D10.5.1 Alcohol, illegal drugs, weapons or other illegal material are prohibited on the event site during the competition. This rule will be in effect during the entire competition.

D10.5.2 Any violation of this rule by a team member will cause the expulsion of the entire team. This applies to both team members and faculty advisors.

D10.5.3 Any use of drugs, or the use of alcohol by an underage individual, will be reported to the local authorities.

### **D10.6 Parties**

In the interest of responsible citizenship it is expected that any disruptive parties, either on or off-site, will be prevented by the Faculty Advisor.

### **D10.7 Trash Clean-up**

D10.7.1 Cleanup of trash and debris is the responsibility of the teams. The team's work area should be kept uncluttered. At the end of the day, each team must clean all debris from their area and help with maintaining a clean paddock.

D10.7.2 Teams are required to remove all of their material and trash when leaving the site at the end of the competition. Teams that abandon furniture, or that leave a paddock that requires special cleaning, will be billed for removal and/or cleanup costs.

## **ARTICLE 11: GENERAL RULES**

### **D11.1 Dynamometer Usage**

If a dynamometer is available, it may be used by any competing team. Vehicles to be dynamometer tested must have passed all parts of technical inspection.

Fuel, ignition and drivetrain tuning will be permitted while testing on the dynamometer.

### **D11.2 Problem Resolution**

Any problems that arise during the competition will be resolved through the Operations Center and the decision will be final.

### **D11.3 Forfeit for Non-Appearance**

D11.3.1 It is the responsibility of each team to be in the right place at the right time.

D11.3.2 If a team is not present and ready to compete at the scheduled time they forfeit their attempt at that event.

D11.3.3 There are no make-ups for missed appearances.

#### **D11.4 Drivers Meetings - Attendance Required**

All drivers for an event are required to attend the pre-event drivers meeting(s). The driver for an event will be disqualified if he/she does not attend the driver meeting or course walk for the event.

#### **D11.5 Personal Vehicles**

Personal cars and trailers must be parked in designated areas only. Only SUPRASAEINDIA competition vehicles will be allowed in the track areas.

#### **D11.6 Motorcycles, Bicycles, Rollerblades, etc.—Prohibited**

The use of motorcycles, quads, bicycles, scooters, skateboards, rollerblades or similar person-carrying devices by team members and spectators in any part of the competition area, including the paddocks, is prohibited.

#### **D11.7 Self-propelled Pit Carts, Tool Boxes, etc. - Prohibited**

The use of self-propelled pit carts, tool boxes, tire carriers or similar motorized devices in any part of the competition site, including the paddocks, is prohibited.

#### **D11.8 Starting**

D11.8.1 Push starts are prohibited.

D11.8.2 The use of auxiliary batteries is prohibited once a car has moved to the starting line of any event.

#### **D11.9 Footwear**

Everyone in a "dynamic" area (an area where cars can be moving under their own power) must wear closed-toed shoes.

### **ARTICLE 12: PIT RULES**

#### **D12.1 Vehicle Movement**

D12.1.1 Vehicles may not move under their own power anywhere but on the practice or competition tracks, or as otherwise directed by the organizers.

D12.1.3 Off track vehicles must be pushed at a normal walking pace by means of a "Push Bar", (See D12.2) and with a driver in the cockpit and with another team member walking beside the car.

*The team has the option to move the car either with (a) all four (4) wheels on the ground or with (b) the rear wheels supported on dollies, by push bar mounted wheels, or other means as long as the person in the cockpit has full control of vehicle movement and can steer and brake normally. The external wheels supporting the rear of the car must be non-pivoting so the vehicle travels only where the front wheels are steered. The driver must always be able to steer and brake the car normally.*

When the pushbar is attached to the car the engine must remain off.

D12.1.4 Cars with wings are required to have two team members walking on either side of the vehicle whenever the vehicle is being pushed.

D12.1.5 During performance events when the excitement is high, it is particularly important that the car be moved at a slow pace in the pits.

D12.1.6 The walking rule will be enforced and a point penalty of twenty five (25) points will be assessed for each violation.

### **D12.2 Push Bar**

D12.2.1 Each car must have a removable device that attaches to the rear of the car that allows two (2) people, standing erect behind the vehicle, to push the car around the event site.



D12.2.2 This device must also be capable of decelerating, i.e. slowing and stopping the forward motion of the vehicle and pulling it rearwards. It must be presented with the car at Technical Inspection.

D12.2.3 A fire extinguisher has to be mounted to the push bar in a way that it is quickly accessible.

### **D12.3 Smoking - Prohibited**

Smoking is prohibited in all competition areas.

### **D12.4 Fueling and Refueling**

Officials must conduct all fueling and refueling.

### **D12.5 Engine and Vehicle Running Requirements**

Engines may be run in the paddock provided the car has passed Parts 1 and 2 of Technical Inspection (S2.7) and the following conditions are satisfied:

- a. The car is on sturdy and adequate stand, and
- b. The drive wheels are at least 10.2 cm (4 in) off the ground, or the driver wheels have been removed.

---

## **ARTICLE 13: DRIVING RULES**

### **D13.1 Driving Under Power**

D13.1.1 Cars may only be driven under power (a) when running in an event, (b) on the practice track and (c) during brake test or (d) during any powered vehicle movement specified and authorized by the organizers.

D13.1.2 For all other movements cars must be pushed at a normal walking pace using a push bar (D12.2).

D13.1.3 Driving a vehicle outside of scheduled events or scheduled practice will result in a two hundred (200) point penalty for the first violation and disqualification for a second violation.

### **D13.2 Driving Off-site - Prohibited**

Driving off-site is absolutely prohibited. Teams found to have driven their vehicle at an off-site location during the period of the competition will be excluded from the competition.

### **D13.3 Practice Track**

D13.3.1 A practice track for testing and tuning cars may be available at the discretion of the organizers. The practice area will be controlled and may only be used during the scheduled practice times.

D13.3.2 Practice or testing at any location other than the practice track is absolutely forbidden.

D13.3.3 Cars using the practice track must have all parts of the technical inspection sticker.

### **D13.4 Situational Awareness**

Drivers must maintain a high state of situational awareness at all times and be ready to respond to the track conditions and incidents. Flag signals and hand signals from course marshals and officials must be immediately obeyed.

## **ARTICLE 14: DEFINITIONS**

**D14.1 DOO** - A cone is "Down or Out" - If the cone has been knocked over or the entire base of the cone lies outside the box marked around the cone in its undisturbed position.

**D14.2 DNF** - Did Not Finish

**D14.3 Gate** - The path between two cones through which the car must pass. Two cones, one on each side of the course define a gate. Two sequential cones in a slalom define a gate.

D14.3.1 **Entry Gate** - The path marked by cones which establishes the required path the vehicle must take to enter the course.

D14.3.2 **Exit Gate** - The path marked by cones which establishes the required path the vehicle must take to exit the course.

---

**D14.4 Staging Area** - An area prior to the entry to an event for the purpose of gathering those cars that are about to start.

**D14.5 OC** - A car is "Off Course" if it does not pass through a gate in the required direction. Please reference the sections on Autocross and Endurance for further definitions of OC as applied to those events.

**RELATED PICTURES FOR STUDENT FORMULA**



**TILT TEST TABLE**

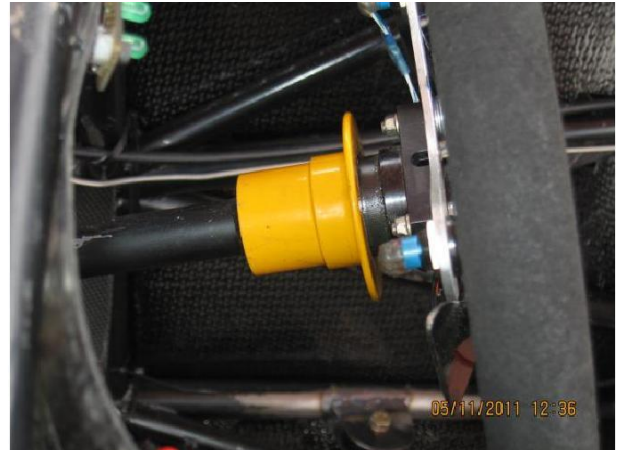

**QUICK RELEASE COUPLING**



**SEAT BELT MOUNTING**



**SCATTER SHIELD**



**ROLL BAR PADING**



**PUSH BAR**





**NOISE TEST LOCATION**



**HELMET CLEARANCE**



**HEAD RESTRAINT**



**HEAD RESTRAIN**



**GAS CANNISTER**



**FRONTAL IMPACT ACTUNUATOR**



**COCKPIT OPENING CHECKING TEMPLATE**



**COCKPIT INTERNAL CROSS SECTION CHECKING TEMPLATE**



**COCKPIT INTERNAL CROSS SECTION CHECKING  
TEMPLATE**



**95th PERCENTIL MALE TEMPLATE**

**3D VIEWS OF THE VEHICLE**

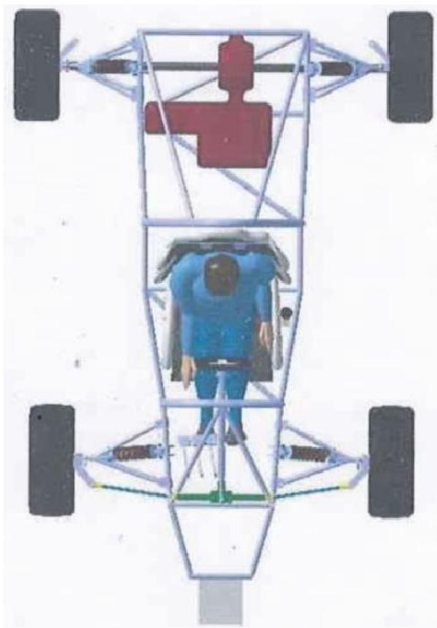



**Quick jack 1**



**Quick jack 2**



**Quick jack 3**



**Quick jack 4**

For Further Details Related to event Please contact: Mr. Bibhu Kumar | [suprasaeindia@saeindia.org](mailto:suprasaeindia@saeindia.org)  
For Any Technical Queries Please Write to [.technicalcommittee.suprasaeindia@saeindia.org](mailto:technicalcommittee.suprasaeindia@saeindia.org)

