

1. Foreword

A: FOREWORD

These manuals are used when performing maintenance, repair or diagnosis of SUBARU IMPREZA WRX and SUBARU IMPREZA WRX STI.

Applicable model: 2013 MY GVE*****, GVF*****, GRE*****, GRF*****

The manuals contain the latest information at the time of publication. Changes in the specifications, methods, etc. may be made without notice.

HOW TO USE THIS MANUALS

HU



	Page
1. How to Use This Manuals	2



How to Use This Manuals

HOW TO USE THIS MANUALS

1. How to Use This Manuals

A: HOW TO USE THIS MANUALS

1. STRUCTURE

Each section consists of SCT that are broken down into SC that are divided into sections for each component. The specification, maintenance and other information for the components are included, and the diagnostic information has also been added where necessary.

2. CONTENTS

The first page has an index with tabs.

3. COMPONENT

Illustrations are provided for each component. The information necessary for repair work (tightening torque, grease up points, etc.) is described on these illustrations. Information is described using symbol.

To order parts, refer to parts catalogue.

Example:

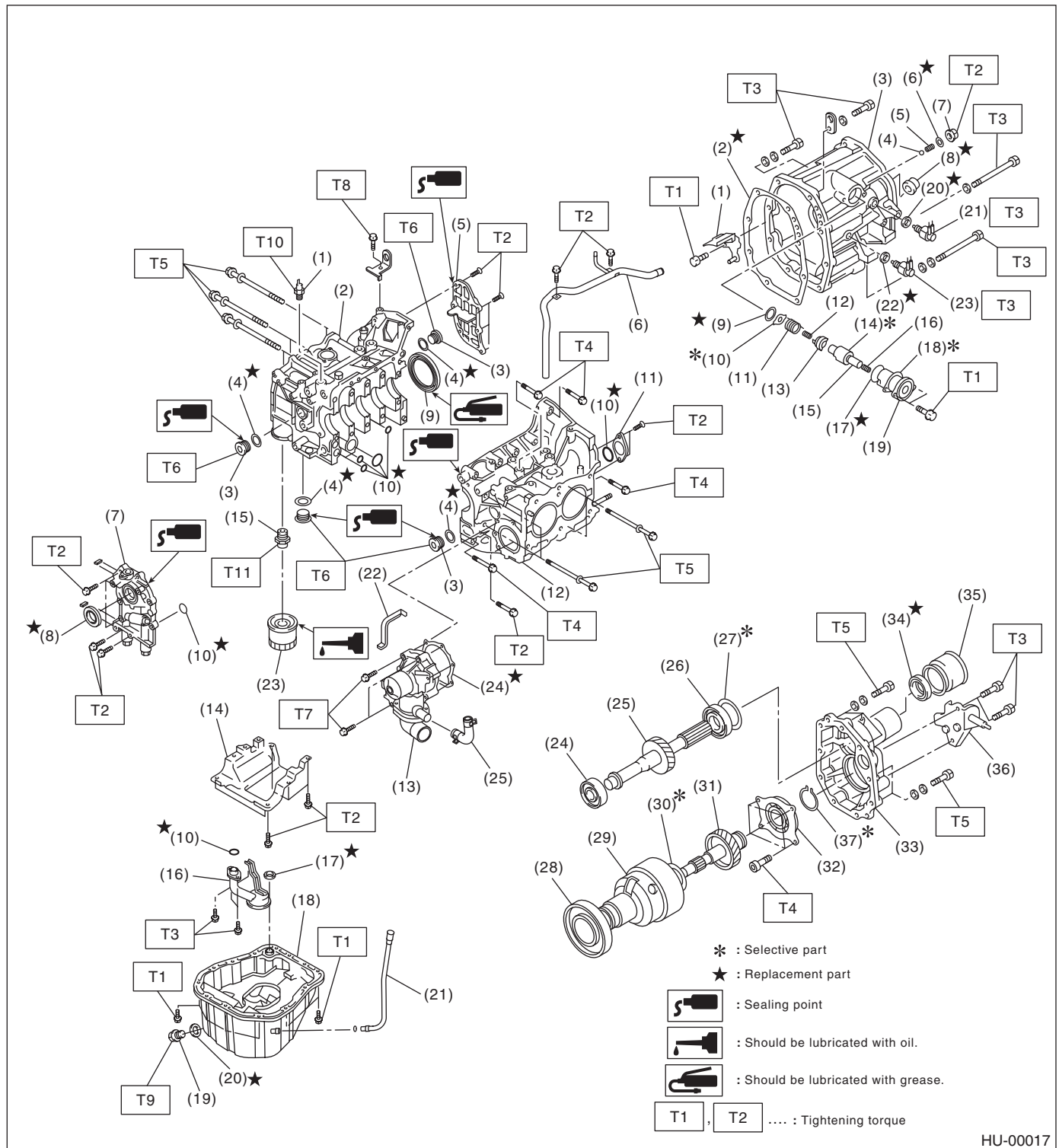

HU-00017

How to Use This Manuals

HOW TO USE THIS MANUALS

4. DEFINITIONS OF “NOTE”, “CAUTION” AND “WARNING”

- **NOTE:**

Describes additional information to make works easier.

- **CAUTION:**

Describes prohibited matters to prevent vehicle or parts damage, or matters that requires special attention during work.

- **WARNING:**

Describes matters that may cause serious damage to the operator or other person, or that may cause damage or accident.

5. SPECIFICATIONS

If necessary, specifications are also included.

6. INSPECTION

Inspections to be carried out before and after maintenance are included.

7. MAINTENANCE

- Maintenance instructions for serviceable parts describe work area and detailed step with illustration. It also describes the use of special tool, tightening torque, caution for each procedure.
- If many serviceable parts are included in one service procedure, appropriate reference is provided for each part.

Example:

15.Main Shaft ← (A)

A: REMOVAL ← (B)

1) Remove the manual transmission assembly from vehicle. <Ref. to MT-33, REMOVAL, Manual Transmission Assembly.> ← (C)

11) Tighten the lock nuts to the specified torque using ST1 and ST2.

NOTE: ← (D)

Secure the lock nuts in two places after tightening.

ST1 498937000 TRANSMISSION HOLDER

ST2 499987003^(E) SOCKET WRENCH (35)^(F)

Tightening torque:

118 N·m (12.0 kgf-m, 86.8 ft-lb) ← (G)

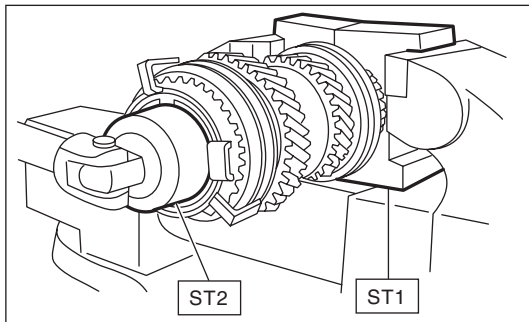

← (H)

HU-00020

(A) Component

(B) Process

(C) Reference

(D) Cautions

(E) Tool number of special tool

(F) Name of special tool

(G) Tightening torque

(H) Illustration

How to Use This Manuals

HOW TO USE THIS MANUALS

8. DIAGNOSIS

Step-by-step process is employed for easier diagnosis.

9. SI UNITS

Measurements in these manuals are according to the SI units. Metric and yard/pound measurements are also included.

Example:

Tightening torque:

44 N·m (4.5 kgf·m, 33 ft·lb)

List of SI unit

Item	SI units	Conventional unit	Remarks
Force	N (Newton)	kgf	1 kgf = 9.807 N
Mass (Weight)	kg, g	kg, g	
Capacity	L, mL or cm ³	L or cc	1 cc = 1 cm ³ = 1 mL
Torque	N·m	kgf·m, kgf·cm	1 kgf·m = 9.807 N·m
Rotating speed	rpm	rpm	
Pressure	kPa (Kilopascal)	kgf/cm ²	1 kgf/cm ² = 98.07 kPa
		mmHg	1 mmHg = 0.1333 kPa
Power	W	PS	1 PS = 0.7355 kW
Calorie	W·h	cal	1 kcal = 1.163 W·h
Fuel consumption rate	g/kW·h	g/PS·h	1 g/PS·h = 1.3596 g/kW·h

The figure used in these manuals are described in the SI units and conventional units are described in ().

10.EXPLANATION OF TERMINOLOGY

List

2ndr	Secondary
AAI	Air Assist Injection
AAR	Angular Adjusted Roller
A/B	Airbag
ABS	Anti-lock Brake System
A/C	Air Conditioner
AC	Angular Contact
ACC	Accessory
A/F	Air Fuel Ratio
ALT	Generator
APS	Accessory Power Supply Socket
ASSY	Assembly
AT	Automatic Transmission
ATF	Automatic Transmission Fluid
AUX	Auxiliary Storage Unit (External storage)
AVCS	Active Valve Control System
AWD	All Wheel Drive
BATT	Battery
BCM	Brake Control Module
BJ	Bell Joint
CAN	Controller Area Network
CD	Compact Disc
CD-R/RW	CD Recordable/Rewritable
COMPL	Complete
CPC	Canister Purge Control Solenoid Valve
CPU	Central Processing Unit
DCCD	Driver's Control Center Differential
DOHC	Double Overhead Camshaft
DOJ	Double Offset Joint
DTC	Diagnosis Trouble Code
DVD	Digital Versatile Disc or Digital Video Disc
EBD	Electronic Brake Distribution
EBJ	High-efficiency Compact Ball Fixed Joint
ECM	Engine Control Module
EDJ	High-efficiency Compact Double Offset Joint
E/G	Engine
EGI	Electronic Gasoline Injection
EGR	Exhaust Gas Recirculation
ELR	Emergency Locking Retractor
ETC	Electronic Throttle Control
EX	Exhaust
F/B	Fuse & Joint Box
FL	Fusible Link
Ft	Front
FWD	Front Wheel Drive
GPS	Global Positioning System
HI	High
HID	High-Intensity Discharge

H/L	Headlight
H/U	Hydraulic Unit
HVAC	Heater, Ventilator and Air Conditioner
I/F	Interface
IG	Ignition
IN	Intake
INT	Intermittent
I/O	Input / Output
IR	Infrared Ray
ISC	Idle Speed Control
LAN	Local Area Network
LCD	Liquid Crystal Display
LED	Light Emitting Diode
LH	LH (Left Hand)
LHD	Left Hand Drive
LSD	Limited Slip Differential
M/B	Main Fuse & Relay Box
MD	Mini Disc
MID	Multi Information Display
MFI	Multi-Point Fuel Injection
MP-T	Multi-Plate Transfer
MT	Manual Transmission
NA	Natural Aspiration
NC	Normal Close (Relay)
NO	Normal Open (Relay)
OBD	On-Board Diagnosis
OP	Option Parts
PC	Personal Computer
PCD	Pitch Circle Diameter
PCV	Positive Crankcase Ventilation
PID	Parameter Identification
Pr	Primary
P/S	Power Steering
PTJ	Pillow Tripod Joint
P/W	Power Window
RAM	Random Access Memory
RH	RH (Right Hand)
RHD	Right Hand Drive
ROM	Read Only Memory
rpm	Revolution Per Minute
Rr	Rear
SDI	Subaru Diagnostic Interface
SI	Subaru Intelligent
SOHC	Single Overhead Camshaft
SRS	Supplemental Restraint System
SSM	Subaru Select Monitor
ST	Special Tool
STD	Standard
SW	Switch

How to Use This Manuals

HOW TO USE THIS MANUALS

T/B	Turbocharger
TCS	Traction Control System
TCM	Transmission Control Module
TGV	Tumble Generator Valve
T/M	Transmission
TPMS	Tire Pressure Monitoring System
UJ	Universal Joint
UV	Ultraviolet
VDC	Vehicle Dynamics Control
V.I.N.	Vehicle Identification Number
ViS-C	Viscous Coupling
VSV	Vacuum Switching Valve
VTD	Variable Torque Distribution
W/H	Wiring Harness

SPECIFICATIONS

SPC

	Page
1. Impreza	2



Impreza

SPECIFICATIONS

1. Impreza

A: DIMENSION

Model		4 door		5 door	
		WRX-S, WRX	STI-S, SE	WRX	STI, SE
Overall length	mm (in)	4,580 (180.3)		4,415 (173.8)	
Overall width	mm (in)	1,795 (70.7)		1,795 (70.7)	
Overall height (at C.W.)	mm (in)	1,475 (58.1)	1,470 (57.9)	1,475 (58.1)	1,470 (57.9)
Compartment	Length	mm (in)	1,985 (78.1)		1,985 (78.1)
	Width	mm (in)	1,475 (58.1)		1,475 (58.1)
	Height	mm (in)	1,200 (47.2), 1,170 (46.1) ^{*1}		1,200 (47.2), 1,170 (46.1) ^{*1}
Wheelbase	mm (in)	2,625 (103.3)		2,625 (103.3)	
Tread	Front	mm (in)	1,530 (60.2)		1,530 (60.2)
	Rear	mm (in)	1,540 (60.6)		1540 (60.6)
Minimum road clearance	mm (in)	155 (6.1)	150 (5.9)	155 (6.1)	150 (5.9)

*1: Model with sunroof

B: ENGINE

Model		2.5 L turbo (WRX-S, WRX model)	2.5 L high power turbo (STI-S, STI, SE model)
Engine type		Horizontally opposed, liquid cooled, 4-cylinder, 4-stroke gasoline engine	
Valve arrangement		DOHC	
Bore × stroke	mm (in)	99.5 × 79.0 (3.92 × 3.11)	
Displacement	cm ³ (cu in)	2,457 (149.94)	
Compression ratio		8.4	8.2
Ignition order		1 — 3 — 2 — 4	
Idle speed	rpm	700±100	
Maximum output	kW (HP)/rpm	198 (265)/6,000	227 (305)/6,000
Maximum torque	N·m (kgf-m, ft-lb)/rpm	330 (33.7, 244)/4,000	394 (40.2, 290)/4,000

C: ELECTRICAL

Model		2.5 L turbo (WRX-S, WRX model)	2.5 L high power turbo (STI-S, STI, SE model)
Ignition timing (at idling)	BTDC	12°±10°	15°±10°
Spark plug	Type and manufacturer	NGK: SILFR6A	
Generator		12 V — 110 A	
Battery	Type and capacity (5HR)	12 V — 48 AH (55D23L)	

D: TRANSMISSION

Transmission type		6MT (except for C6 models)	6MT (C6 models)	5MT
Clutch type		DSPD		
Gear ratio	1st	3.636		3.166
	2nd	2.235		1.882
	3rd	1.521	1.590	1.296
	4th	1.137		0.972
	5th	0.971	0.891	0.738
	6th	0.756	0.707	—
	Reverse	3.545		3.333
Reduction gear (Front)	Final reduction	Type of gear	Hypoid	
		Gear ratio	3.900	
Reduction gear (Rear)	Transfer reduction	Type of gear	Helical	
		Gear ratio	1.103	1.000
	Final reduction	Type of gear	Hypoid	
		Gear ratio	3.545	3.900

6MT: 6-forward speeds and 1-reverse with synchromesh

5MT: 5-forward speeds and 1-reverse with synchromesh

DSPD: Dry Single Plate Diaphragm

E: STEERING

Type	Rack and pinion		
Turns, lock to lock	2.8		
Minimum turning diameter	m (ft)	Curb to curb	11.0 (36.1)
		Wall to wall	11.8 (38.7)

F: SUSPENSION

Front	Macpherson strut type suspension
Rear	Double-wishbone type suspension

Impreza

SPECIFICATIONS

G: BRAKE

Model	WRX-S, WRX	STI-S, STI, SE
Service brake system	Dual circuit hydraulic with vacuum suspended power unit	
Front	Ventilated disc brake	
Rear	Disc brake	Ventilated disc brake
Parking brake	Mechanical on rear brakes	

H: TIRE

Rim size	17 × 8J	18 × 8 1/2J
Tire size	235/45R17	245/40R18
Type	Tubeless, Steel belted radial	

I: CAPACITY

Model		WRX-S, WRX	STI-S, STI, SE
Fuel tank	L (US gal, Imp gal)	64 (16.9, 14.1)	
Engine oil	Total capacity (at overhaul)	5.0 (5.3, 4.4)	
	When replacing engine oil and oil filter	4.2 (4.4, 3.7)	4.3 (4.5, 3.8)
	When replacing engine oil only	4.0 (4.2, 3.5)	
Transmission gear oil	L (US qt, Imp qt)	3.5 (3.7, 3.1)	4.1 (4.3, 3.6)
Rear differential gear oil	L (US qt, Imp qt)	0.8 (0.8, 0.7)	1.0 (1.1, 0.9)
Power steering fluid	L (US qt, Imp qt)	0.7 (0.7, 0.6)	
Engine coolant	L (US qt, Imp qt)	7.4 (7.8, 6.5)	7.7 (8.1, 6.8)

J: WEIGHT

Model		4 door									
		2.5 L DOHC turbo									
		WRX	WRX-S								
		5MT	5MT								
OP code		U4	C0	C0	C4	U4	U4	U4	U4	U4	
		TX	TR	CH	4H	TX	4 R	5 R	OH	QH	
Vehicle weight (C.W.)	Total	kg (lb)	1,455 (3,208)	1,455 (3,208)	1,475 (3,252)	1,475 (3,252)	1,455 (3,208)	1,470 (3,241)	1,470 (3,241)	1,475 (3,252)	1,475 (3,252)
	Front	kg (lb)	830 (1,830)	830 (1,830)	840 (1,852)	840 (1,852)	830 (1,830)	835 (1,841)	835 (1,841)	840 (1,852)	840 (1,852)
	Rear	kg (lb)	625 (1,378)	625 (1,378)	635 (1,400)	635 (1,400)	625 (1,378)	635 (1,400)	635 (1,400)	635 (1,400)	635 (1,400)
Gross vehicle weight (G.V.W.)		kg (lb)	1,990 (4,387)	1,990 (4,387)	1,990 (4,387)	1,990 (4,387)	1,990 (4,387)	1,990 (4,387)	1,990 (4,387)	1,990 (4,387)	1,990 (4,387)
Gross axle weight (G.A.W.)	Front	kg (lb)	1,020 (2,249)	1,020 (2,249)	1,020 (2,249)	1,020 (2,249)	1,020 (2,249)	1,020 (2,249)	1,020 (2,249)	1,020 (2,249)	1,020 (2,249)
	Rear	kg (lb)	1,030 (2,271)	1,030 (2,271)	1,030 (2,271)	1,030 (2,271)	1,030 (2,271)	1,030 (2,271)	1,030 (2,271)	1,030 (2,271)	1,030 (2,271)
Option	Aluminum wheel 18 in (BBS)		—	—	—	—	—	—	—	—	—
	Navigation		—	—	—	—	—	—	○	—	○
	Sunroof		—	—	○	○	—	○	○	○	○
	HID		—	—	—	—	—	—	—	○	○
	Front fog light		—	—	○	○	—	○	○	○	○
	Genuine leather seat		—	—	○	○	—	—	—	○	○
	Seat heater		—	○	○	○	—	○	○	○	○
	Cold weather package		—	○	○	○	—	○	○	○	○
	Satellite tuner		—	—	○	—	—	—	—	—	—
	Side airbag		○	○	○	○	○	○	○	○	○
	Curtain airbag		○	○	○	○	○	○	○	○	○

Impreza

SPECIFICATIONS

Model		4 door											
		2.5 L DOHC high power turbo											
		STI-S									SE		
		6MT									6MT		
OP code		C0	C4	C6	C6	U4	U4	U4	U4	U4	C0	U4	
		OR	SH	OH	OR	3 R	MR	SH	UH	VR	TR	TX	
Vehicle weight (C.W.)	Total	kg (lb)	1,550 (3,417)	1,550 (3,417)	1,550 (3,417)	1,550 (3,417)	1,535 (3,384)	1,535 (3,384)	1,550 (3,417)	1,550 (3,417)	1,535 (3,384)	1,535 (3,384)	1,535 (3,384)
	Front	kg (lb)	890 (1,962)	890 (1,962)	890 (1,962)	890 (1,962)	885 (1,951)	885 (1,951)	890 (1,962)	890 (1,962)	885 (1,951)	885 (1,951)	885 (1,951)
	Rear	kg (lb)	660 (1,455)	660 (1,455)	660 (1,455)	660 (1,455)	650 (1,433)	650 (1,433)	660 (1,455)	660 (1,455)	650 (1,433)	650 (1,433)	650 (1,433)
Gross vehicle weight (G.V.W.)		kg (lb)	2,030 (4,475)	2,030 (4,475)	2,030 (4,475)	2,030 (4,475)	2,030 (4,475)	2,030 (4,475)	2,030 (4,475)	2,030 (4,475)	2,030 (4,475)	2,030 (4,475)	2,030 (4,475)
Gross axle weight (G.A.W.)	Front	kg (lb)	1,050 (2,315)	1,050 (2,315)	1,050 (2,315)	1,050 (2,315)	1,050 (2,315)	1,050 (2,315)	1,050 (2,315)	1,050 (2,315)	1,050 (2,315)	1,050 (2,315)	1,050 (2,315)
	Rear	kg (lb)	1,040 (2,293)	1,040 (2,293)	1,040 (2,293)	1,040 (2,293)	1,040 (2,293)	1,040 (2,293)	1,040 (2,293)	1,040 (2,293)	1,040 (2,293)	1,040 (2,293)	1,040 (2,293)
Option	Aluminum wheel 18 in (BBS)		—	○	—	—	○	—	○	○	—	—	—
	Navigation		—	—	—	—	○	—	—	○	○	—	—
	Sunroof		○	○	○	○	—	—	○	○	—	—	—
	HID		○	○	○	○	○	○	○	○	○	—	—
	Front fog light		○	○	○	○	○	—	○	○	—	—	—
	Genuine leather seat		—	○	○	—	—	—	○	○	—	—	—
	Seat heater		○	○	○	○	○	○	○	○	○	○	—
	Cold weather package		○	○	○	○	○	○	○	○	○	○	—
	Satellite tuner		—	—	—	—	—	—	—	—	—	—	—
	Side airbag		○	○	○	○	○	○	○	○	○	○	○
	Curtain airbag		○	○	○	○	○	○	○	○	○	○	○

Impreza

SPECIFICATIONS

Model		5 door								
		2.5 L DOHC turbo								
		WRX								
		5MT								
OP code		C0	C0	C4	U4	U4	U4	U4	U4	
		TR	CH	4H	TX	4 R	5 R	OH	QH	
Vehicle weight (C.W.)	Total	kg (lb)	1,455 (3,208)	1,475 (3,252)	1,475 (3,252)	1,455 (3,208)	1,470 (3,241)	1,470 (3,241)	1,475 (3,252)	1,475 (3,252)
	Front	kg (lb)	830 (1,830)	840 (1,852)	840 (1,852)	830 (1,830)	835 (1,841)	835 (1,841)	840 (1,852)	840 (1,852)
	Rear	kg (lb)	625 (1,378)	635 (1,400)	635 (1,400)	625 (1,378)	635 (1,400)	635 (1,400)	635 (1,400)	635 (1,400)
Gross vehicle weight (G.V.W.)		kg (lb)	1,990 (4,387)	1,990 (4,387)	1,990 (4,387)	1,990 (4,387)	1,990 (4,387)	1,990 (4,387)	1,990 (4,387)	1,990 (4,387)
Gross axle weight (G.A.W.)	Front	kg (lb)	1,020 (2,249)	1,020 (2,249)	1,020 (2,249)	1,020 (2,249)	1,020 (2,249)	1,020 (2,249)	1,020 (2,249)	1,020 (2,249)
	Rear	kg (lb)	1,030 (2,271)	1,030 (2,271)	1,030 (2,271)	1,030 (2,271)	1,030 (2,271)	1,030 (2,271)	1,030 (2,271)	1,030 (2,271)
Option	Aluminum wheel 18 in (BBS)		—	—	—	—	—	—	—	—
	Navigation		—	—	—	—	—	○	—	○
	Sunroof		—	○	○	—	○	○	○	○
	HID		—	—	—	—	—	—	○	○
	Front fog light		—	○	○	—	○	○	○	○
	Genuine leather seat		—	○	○	—	—	—	○	○
	Seat heater		○	○	○	—	○	○	○	○
	Cold weather package		○	○	○	—	○	○	○	○
	Satellite tuner		—	○	—	—	—	—	—	—
	Side airbag		○	○	○	○	○	○	○	○
	Curtain airbag		○	○	○	○	○	○	○	○

Impreza

SPECIFICATIONS

Model		5 door						
		2.5 L DOHC high power turbo						
		STI			SE			
		6MT			6MT			
OP code		C0	C4	U4	U4	C0	U4	
		OR	SH	3 R	RR	TR	TX	
Vehicle weight (C.W.)	Total	kg (lb)	1,545 (3,406)	1,545 (3,406)	1,530 (3,373)	1,530 (3,373)	1,530 (3,373)	1,530 (3,373)
	Front	kg (lb)	890 (1,962)	890 (1,962)	885 (1,951)	885 (1,951)	885 (1,951)	885 (1,951)
	Rear	kg (lb)	655 (1,444)	655 (1,444)	645 (1,422)	645 (1,422)	645 (1,422)	645 (1,422)
Gross vehicle weight (G.V.W.)		kg (lb)	2,030 (4,475)	2,030 (4,475)	2,030 (4,475)	2,030 (4,475)	2,030 (4,475)	2,030 (4,475)
Gross axle weight (G.A.W.)	Front	kg (lb)	1,050 (2,315)	1,050 (2,315)	1,050 (2,315)	1,050 (2,315)	1,050 (2,315)	1,050 (2,315)
	Rear	kg (lb)	1,040 (2,293)	1,040 (2,293)	1,040 (2,293)	1,040 (2,293)	1,040 (2,293)	1,040 (2,293)
Option	Aluminum wheel 18 in (BBS)		—	○	○	○	—	—
	Navigation		—	—	○	—	—	—
	Sunroof		○	○	—	—	—	—
	HID		○	○	○	○	—	—
	Front fog light		○	○	○	○	—	—
	Genuine leather seat		—	○	—	—	—	—
	Seat heater		○	○	○	○	○	—
	Cold weather package		○	○	○	○	○	—
	Satellite tuner		—	—	—	—	—	—
	Side airbag		○	○	○	○	○	○
	Curtain airbag		○	○	○	○	○	○

PRECAUTION

PC

	Page
1. Precaution	2



1. Precaution

A: CAUTION

Please clearly understand and adhere to the following general precautions for environmental protection and to avoid minor or serious injury to the person doing the work or people in the area.

1. VEHICLE DYNAMICS CONTROL (VDC)

Handle the VDC as a total system. Do not disassemble or attempt to repair individual parts. Follow the directions in this manual when performing maintenance on the VDCCM&H/U. When parts other than those specified are disassembled, it is possible that the VDC system will not operate when needed or cause it to operate incorrectly and result in injury.

2. BRAKE FLUID

If brake fluid gets in your eyes or on your skin, do the following:

- Wash eyes and seek immediate medical attention.
- Wash your skin with soap and then rinse thoroughly with water.

3. RADIATOR FAN

The radiator fan may rotate without warning, even when the engine is not ON. Do not place your hand, cloth, tools or other items near the fan at any time.

4. ROAD TEST

Always conduct road tests in accordance with traffic rules and regulations to avoid bodily injury and interrupting traffic.

5. AIRBAG

To prevent bodily injury from unexpected deployment of airbags and unnecessary maintenance, follow the instructions in this manual when performing maintenance on the airbag components or nearby, around front of the vehicle (radiator panel, front wheel apron, front side frame, bumper, hood, front fender), around side of the vehicle (front door, rear door, center pillar, rear fender, side sill, rear wheel apron), around rear of the vehicle (rear seat cushion, rear floor, rear crossmember) and the airbag wiring harnesses or nearby.

To prevent unexpected deployment, turn the ignition switch to OFF and disconnect the ground cable from battery, then wait at least 60 seconds before starting work.

6. AIRBAG DISPOSAL

To prevent bodily injury from unexpected airbag deployment, do not dispose the airbag modules in the same way as other waste. Follow all government regulations concerning disposal of refuse.

7. AIRBAG MODULE

Adhere to the following when handling and storing the airbag module to prevent bodily injury from unexpected deployment:

- Do not hold the harnesses or connectors to carry the module.
- Do not face the bag in the direction that it opens towards yourself or other people.
- Do not face the bag in the direction that it opens towards the floor or walls.

8. AIRBAG SPECIAL TOOL

To prevent unexpected deployment, only use special tools.

9. WINDOW

Always wear safety glasses when working around any glass to prevent glass fragments from damaging your eyes.

10. WINDOW ADHESIVE

Always use the recommended or equivalent adhesive when attaching glass to prevent it from falling off, resulting in accidents and injury.

11. OIL

When handling oil, adhere to the following to prevent unexpected accident.

- Prepare a container and cloth to prevent scattering of oil when performing work where oil can be spilled. If the oil spills, wipe it off immediately to prevent from penetrating into floor or flowing out for environmental protection.
- Follow all government and local regulations concerning disposal of refuse when disposing.

12. FUEL

When handling and storing fuel, adhere to the following to prevent from unexpected accident.

- Be careful with fire.
- Prepare a container and cloth to prevent scattering of fuels when performing work where fuels can be spilled. If the oil spills, wipe it off immediately to prevent from penetrating into floor or flowing out for environmental protection.
- Follow all government and local regulations concerning disposal of refuse when disposing.

13. ENGINE COOLANT

When handling engine coolant, adhere to the following to prevent from unexpected accident.

- Never remove the radiator cap since engine coolant may blow out when it is hot.
- Prepare a container and cloth to prevent scattering of engine coolant when performing work where engine coolant can be spilled. If the oil spills, wipe it off immediately to prevent from penetrating into floor or flowing out for environmental protection.
- Follow all government and local regulations concerning disposal of refuse when disposing.

14. AIR CONDITIONER REFRIGERANT

In order to prevent from global warming, avoid releasing air conditioner refrigerant into the atmosphere. Using a refrigerant recovery system, discharge and recycle it.

15. REMOVAL AND INSTALLATION OPERATION OF HOSES, ETC.

1. Before the removal and installation operation of hoses, etc.

- If you keep using the damaged or deformed hose, it results bleeds or leakage of the fat adheres or disconnection of the hose. Be careful not to spill fat adheres on exhaust pipes, etc. during maintenance to prevent emitting smoke or causing fires.
- Perform the operation with the hose removed. If the operation is performed without removing the hose, it may damage inner surface of the hose.

2. Removal and installation operation of hoses, etc. during the inspection

- Follow the instructions below when removing hose.
 - Do not use a pointed hose remover (hose plucker) when using a general hose remover. It may damage the pipe surface or the hose.

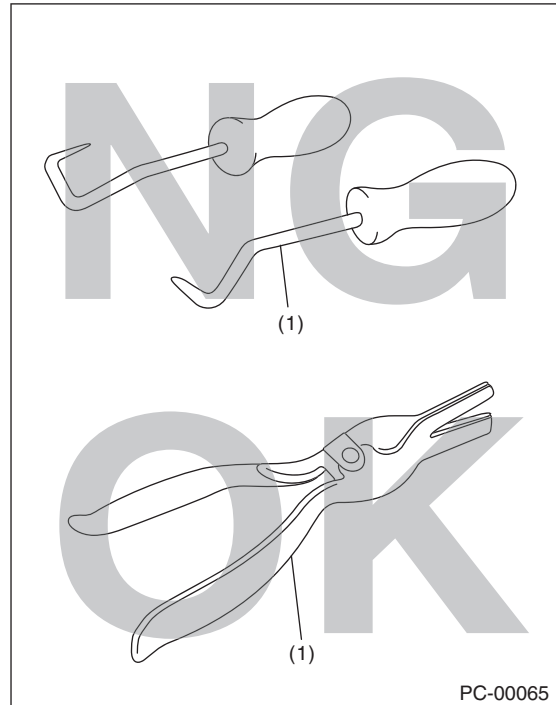

(1) Hose remover

- When draining hose using pliers, be sure to cover the hose with cloth and rotate the hose slightly to extract straight.

Precaution

PRECAUTION

• If you keep using the hose, perform the inspection below and replace the hose with a new part if faulty.

- Replace the hose with a new part if it rides over the stay or the top of spool.

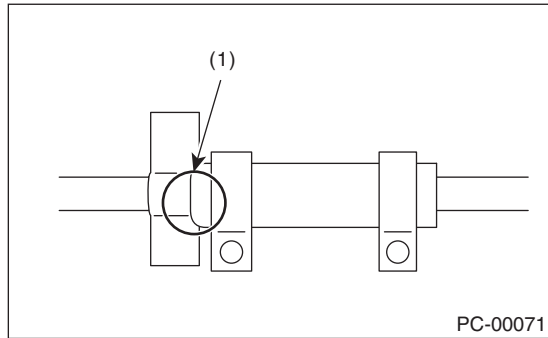

(1) Hose rides over the stay

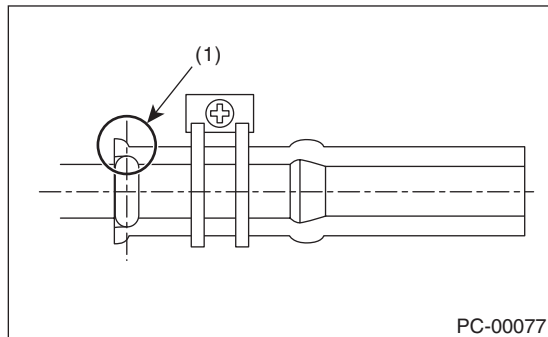

(1) Hose rides over the top of spool

- Check if the surface and the inner surface of the hose are damaged, cracked, bend, hardened, softened, swelled, peeled or deformed due to the adherence or the entry of the foreign matter by bending the hose. Replace with the new part if faulty.

• Follow the instructions below during installation.

- Check carefully for assembling position.
- Never use lubricants.
- Insert the hose to the specified position (stopper or spool) securely. (The stopper of the spool is between the top of the spool and the bottom section.)

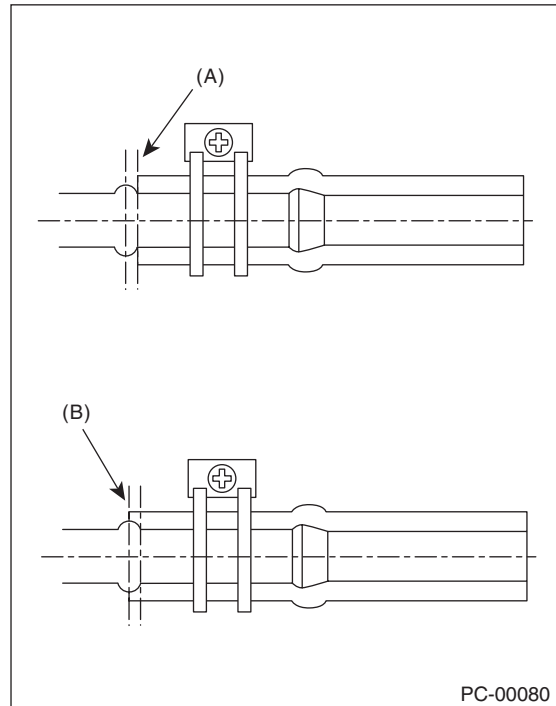
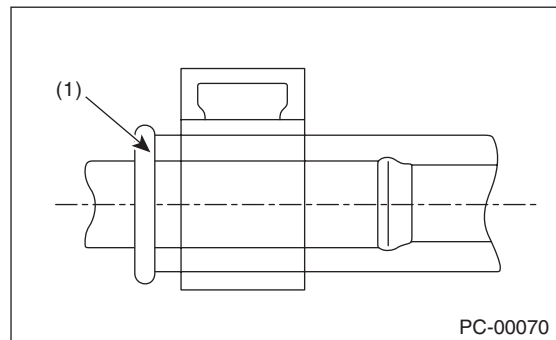
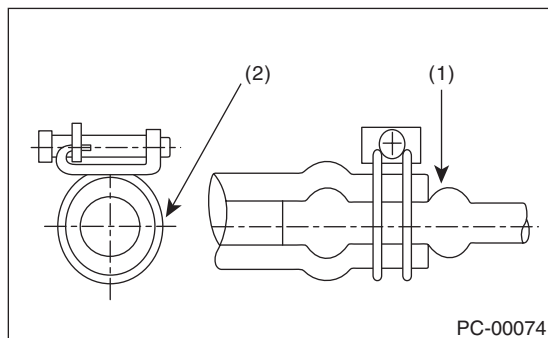

- (1) Push against the spool. (Insert the hose and prevent it from becoming wrinkled.)
 - (2) Tighten the hose outwards and apply force thoroughly.
- (A) OK position (bottom of spool)
(B) OK position (top of spool)

- Check if the position, direction and hose layout of the hose clamp are correct. (Check if the position, direction, length and the gap around are correct, or if it is different from the condition before the work)
- After the installation, check that the hose is installed securely and there is no leakage. (Check if it is fixed securely with the clamp)

- **For hose clips and hose clamps, perform the inspection below and replace them with a new part if faulty.**

- Check for deformation, rust, damage or foreign matters.
- For hose clip, check if it works and has clamping force.
- For hose clamp, check if it can tighten screw, not ovalized or the screw is not damaged.

- **For hose pipes, perform the inspection below and replace with a new part if faulty.**

Check if the pipe is not damaged, rusted, peeled (peeled plates included), covered with foreign matter, bent, compressed or cracked.

- **For the parts below, replaces with a new part when the hose is removed or the installation position is changed.**

Engine oil cooler hose, power steering suction hose, power steering return hose, fuel hose (delivery/return)

Precaution

PRECAUTION

16.HANDLING PRECAUTIONS FOR SILICON-CONTAINING SPRAY

When a silicone contained in the lubricant, rust inhibitor or glazing agent adheres to the electrical contact of the relay or switch, nonconducting silica dioxide (SiO_2) film will be formed, which may lead to poor continuity. Therefore, the following precautions must be observed when using the silicon-containing spray.

- Never spray directly to the electrical equipment.
- When using the spray close to the electrical equipment, always put the cover on it. Be sure to put the cover on the electrical equipment especially when using the spray to the locations shown in the figure below and their surrounding areas.

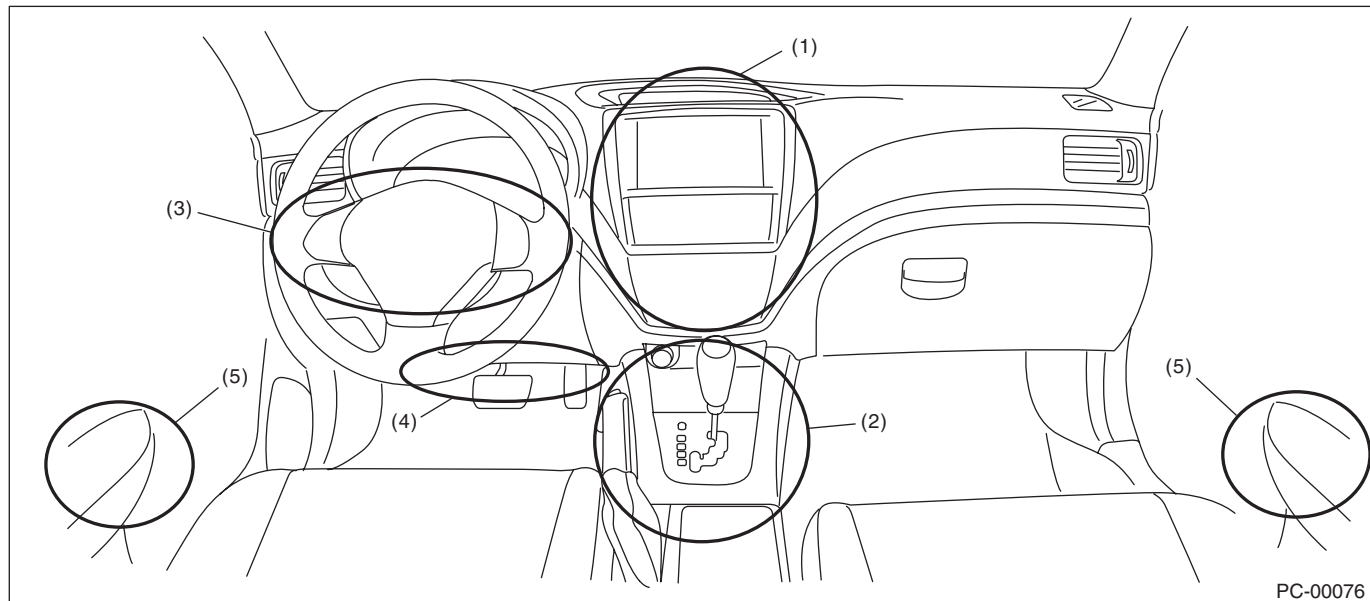

PC-00076

- | | | |
|---|---|-------------------------|
| (1) Audio, heater control switch | (3) Combination switch, steering switch | (5) Power window switch |
| (2) Shift/select lever switch, parking switch | (4) Stop light switch, brake light switch, clutch switch, clutch start switch | |

- If the residual silicon remains in the vicinity of the electrical equipment after the spray has been used, the vaporized silicon stands around the electrical equipment and it may adhere to electrical contact. After using the spray, be sure to wipe the silicon off with a cloth.
- Even when using the spray to the place away from the electrical equipment, the droplet of the spray may be splashed to the periphery. Use as small amount of spray as possible, and take care not to splash the silicon to the periphery.

NOTE:

The "silicon" used in this section refers to "silicone", that is, silicon polymer.

NOTE

NT

	Page
1. Note	2



1. Note

A: NOTE

This information will improve the efficiency of maintenance and assure the sound work.

1. CLEANING

- Perform the operation in a clean location and use extra caution in dust proofing.
- Clean the items (except for assembly components) with steam, etc. before disassembly. During steam cleaning, wrap the air breather, oil level gauge, connectors, etc. with vinyl tape to prevent steam from entering inside the parts.
- For cleaning solution, use new kerosene, etc.
- Do not clean rubber parts such as O-ring, gasket and oil seal with cleaning solution.

2. FASTENERS NOTICE

Fasteners are used to prevent the parts from damage, dislocation and play due to looseness. Fasteners must be tightened to the specified torque. Do not apply paint, lubricant, rust retardant or other substance to the surface around bolts, nuts, etc. Doing so will make it difficult to obtain the correct torque and result in looseness and other problem.

3. STATIC ELECTRICITY DAMAGE

Do not touch the control modules, connectors, logic boards and other such parts when there is a risk of static electricity. Always use a static electricity prevention cord or touch grounded metal for the elimination of static electricity before conducting work.

4. BATTERY

When removing the battery cables, always be sure to turn the ignition switch to OFF to prevent electrical damage to the control module from overcurrent. Be sure to remove the battery ground cable first.

5. IMMOBILIZER RELATED PART

Do not replace parts which have immobilizer ID (ignition key, combination meter, body integrated unit and ECM) with the parts from other vehicle.

6. SERVICE PARTS

Use genuine parts for maximum performance and maintenance when conducting repairs. Subaru/FHI will not be responsible for poor performance resulting from the use of parts except for genuine parts.

7. PROTECTING VEHICLE UNDER MAINTENANCE

Make sure to attach the fender cover, seat covers, etc. before work.

8. ENSURING SECURITY DURING WORK

When working in a group of two or more, perform the work with calling each other to ensure mutual safety.

9. LIFT AND JACK

When using a lift or shop jack to raise a vehicle or using rigid rack to support a vehicle, always follow instructions concerning jack-up points and weight limits to prevent the vehicle from falling, which could result in injury. Be especially careful that the vehicle is balanced before raising it. Be sure to set the wheel stoppers when jacking-up only the front or rear side of the vehicle.

CAUTION:

Not to let the side sill cover interfere with the lift arm, use an attachment. When the side sill interferes with the lift arm, a grooveless attachment can be used. In this case, perform the operation carefully because the dislocation from the side sill flange may occur.

NOTE:

- When using a lift, follow its operation manual.
- When using, insert the body flange to the attachment groove.
- When the side sill spoiler contacts the lift arm, use a lift attachment.
- Do not work or leave unattended while the vehicle is supported with jack, support it with rigid racks.
- Be sure to use the rigid racks with rubber attached to cradle to support the vehicle.
- When using a plate lift, use a rubber attachment. Place the attachment to the specified position of the vehicle, by adjusting front/rear and left/right sides accordingly.

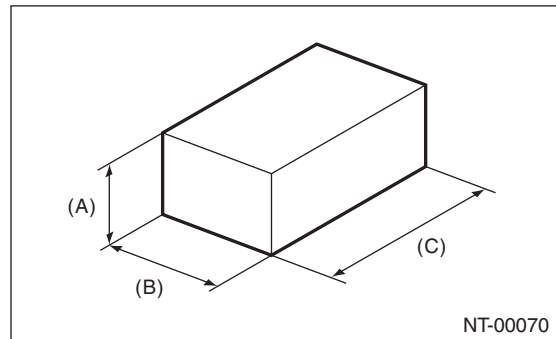

- (A) 80 mm (3.1 in) or more
- (B) 80 — 100 mm (3.15 — 3.94 in)
- (C) 120 — 170 mm (4.72 — 6.69 in)

- When using an attachment, align the center of attachment (A) with the center of vehicle rib (the center of spoiler rib).

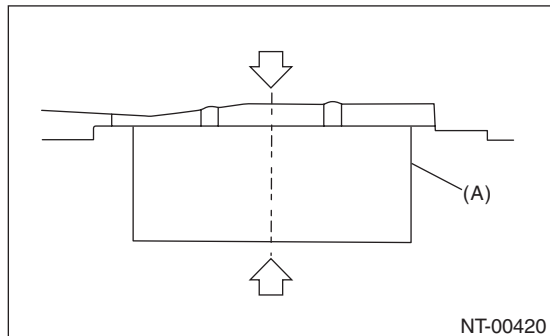

- Do not use the plate lift whose attachment does not reach the supporting locations.
Support locations

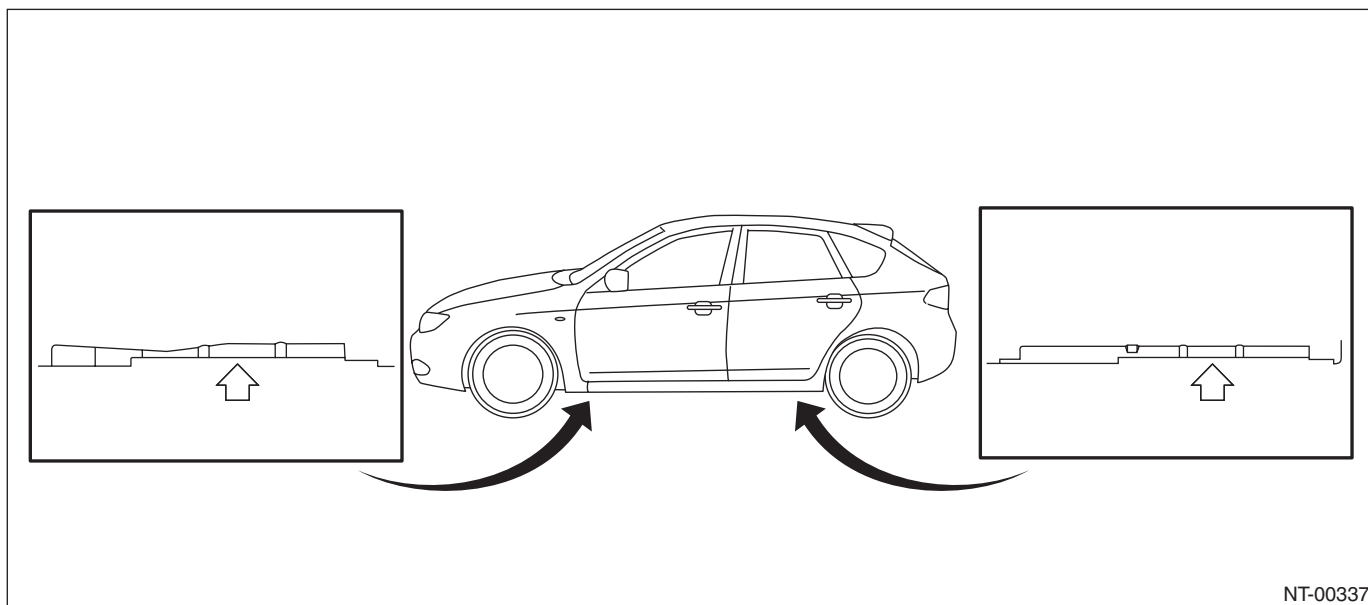

Pantograph jack
Set the jacks between protruding portions.

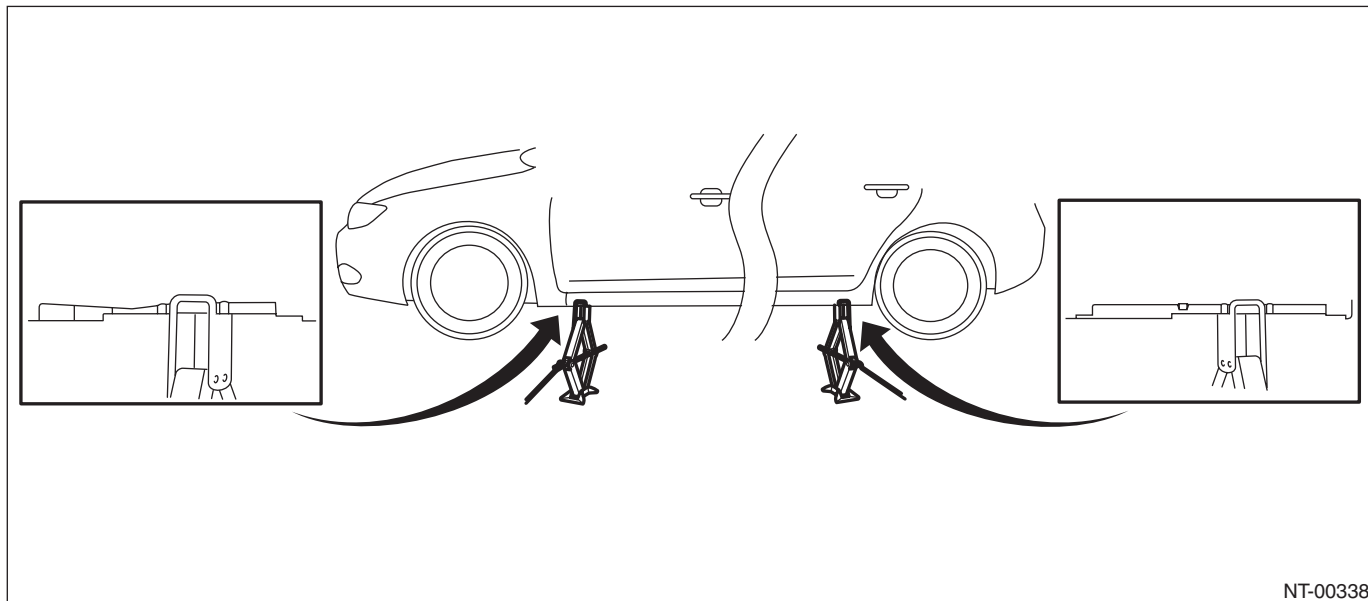

Note

NOTE

Lift

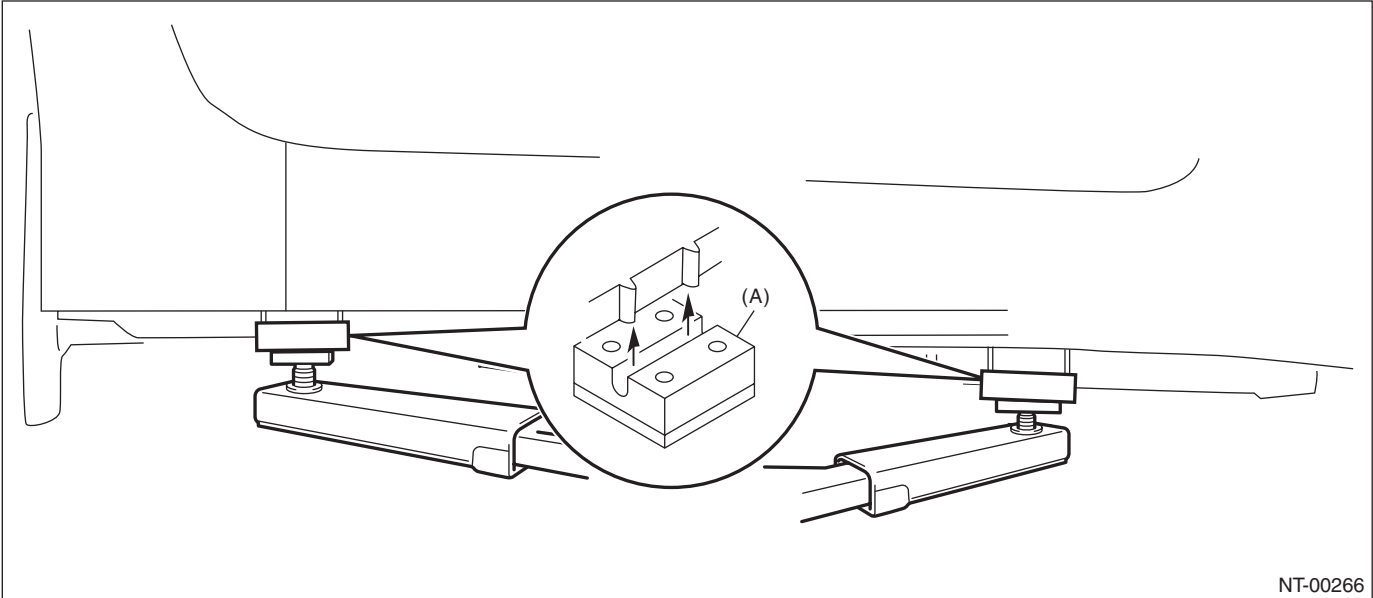

(A) Attachment

Rigid rack

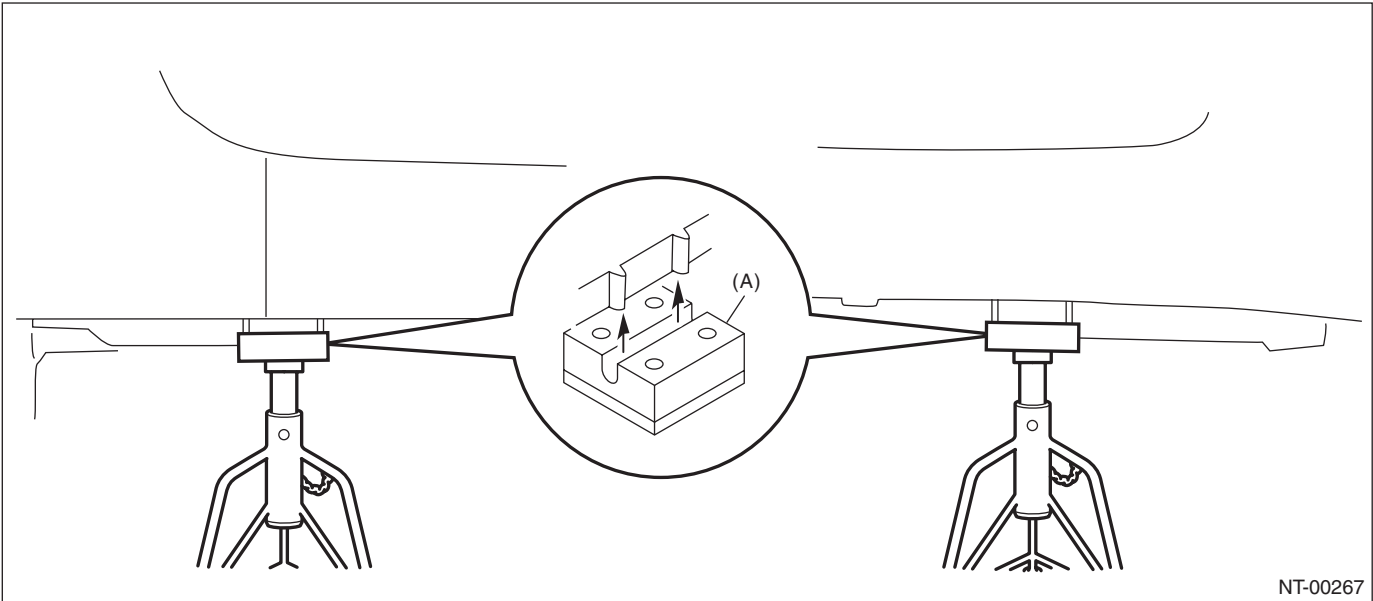

(A) Attachment

Plate lift

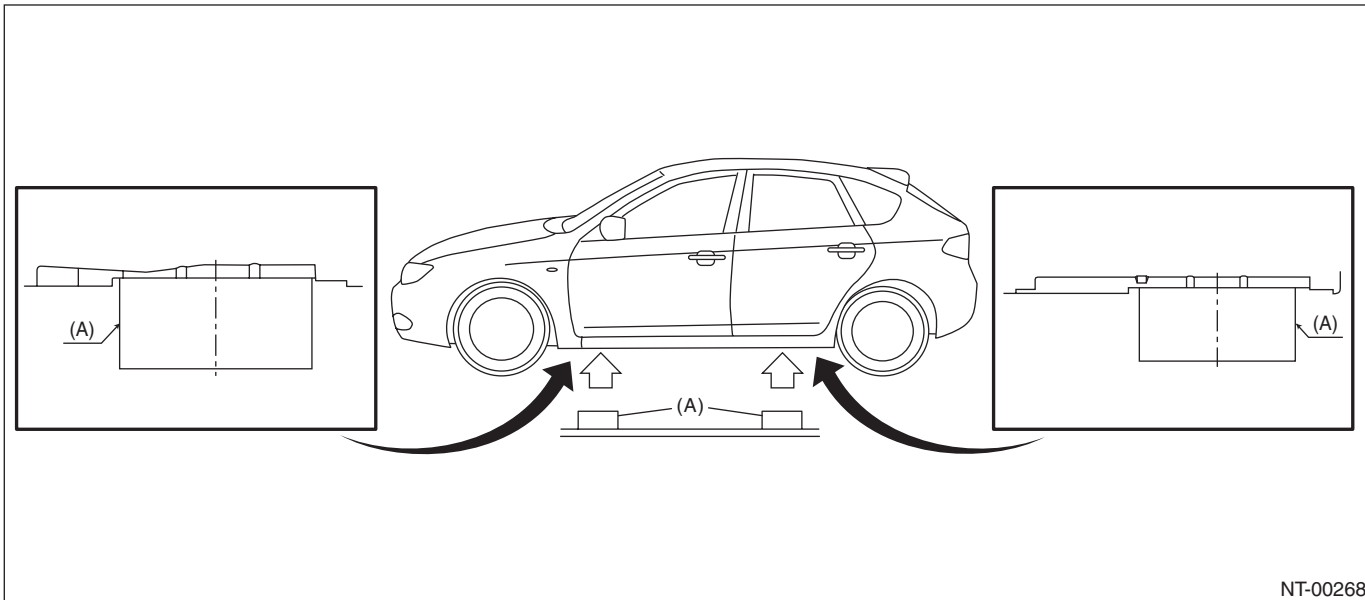

NT-00268

(A) Attachment

Garage jack

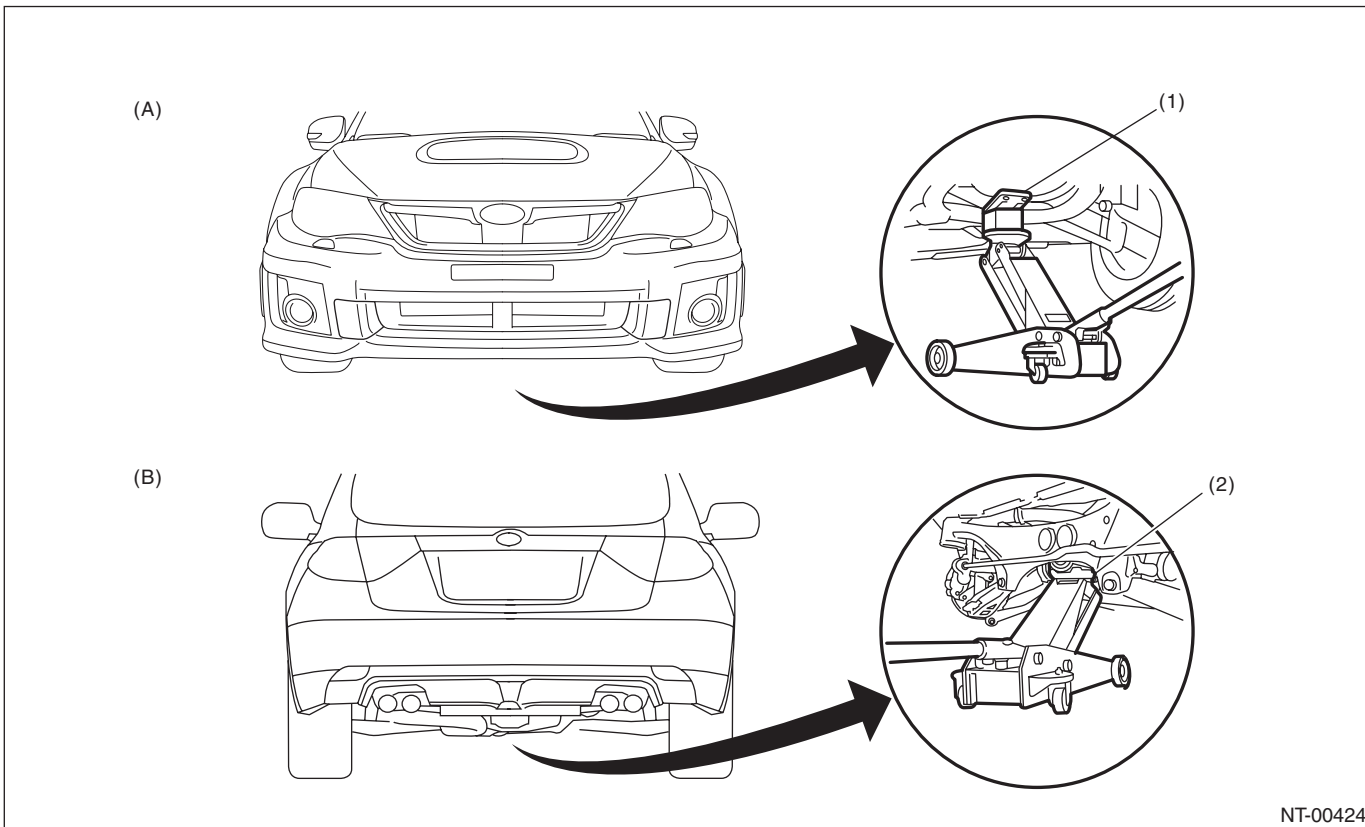

NT-00424

(A) Front

(B) Rear

(1) Front crossmember

(2) Rear differential

Note

NOTE

10.TIE-DOWNS

The tie-down hooks are used when transporting vehicles and when using the chassis dynamo. Attach tie-down only to the specified locations on the vehicle.

- Tie-down location

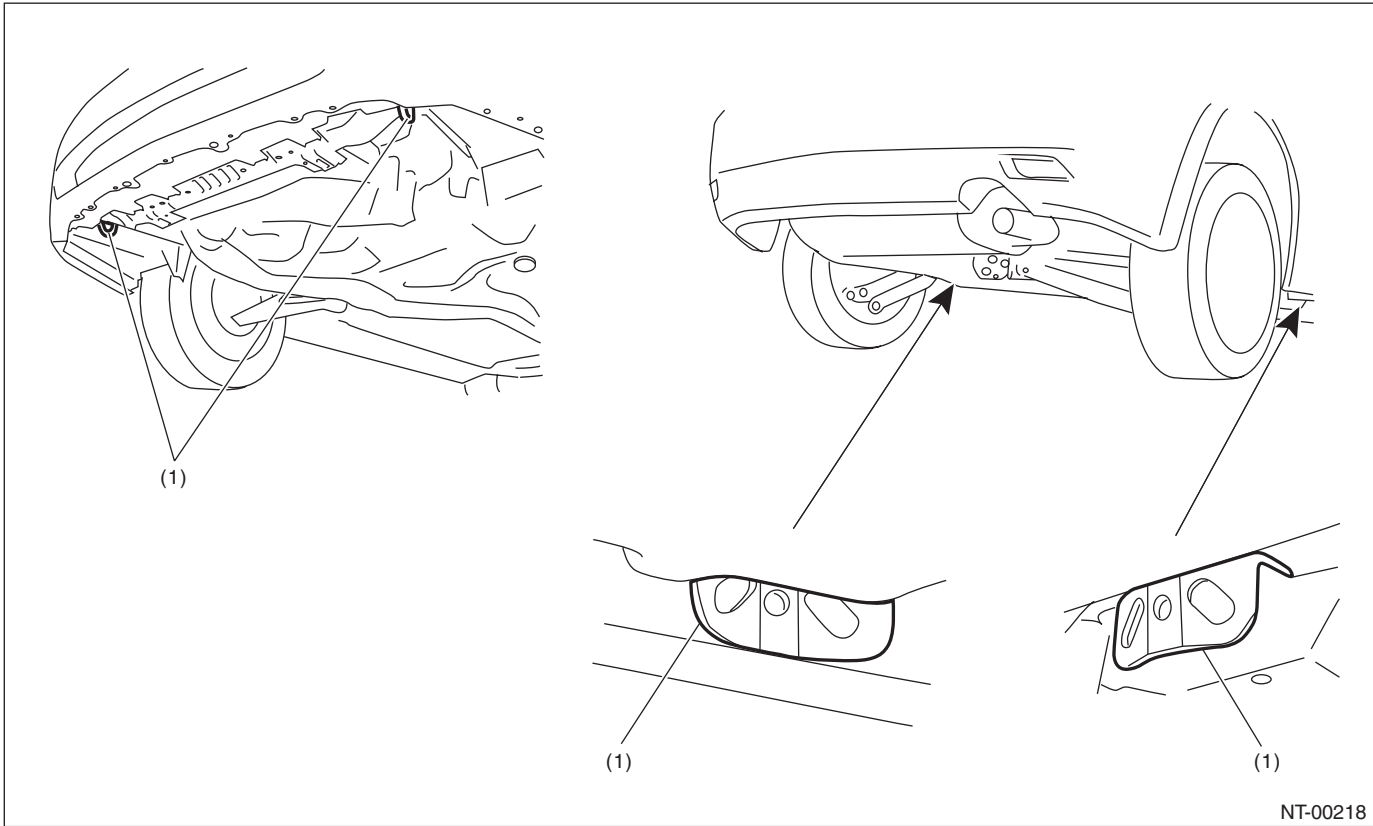

NT-00218

(1) Hook for tie-down

• Tie-down hook & eye bolt

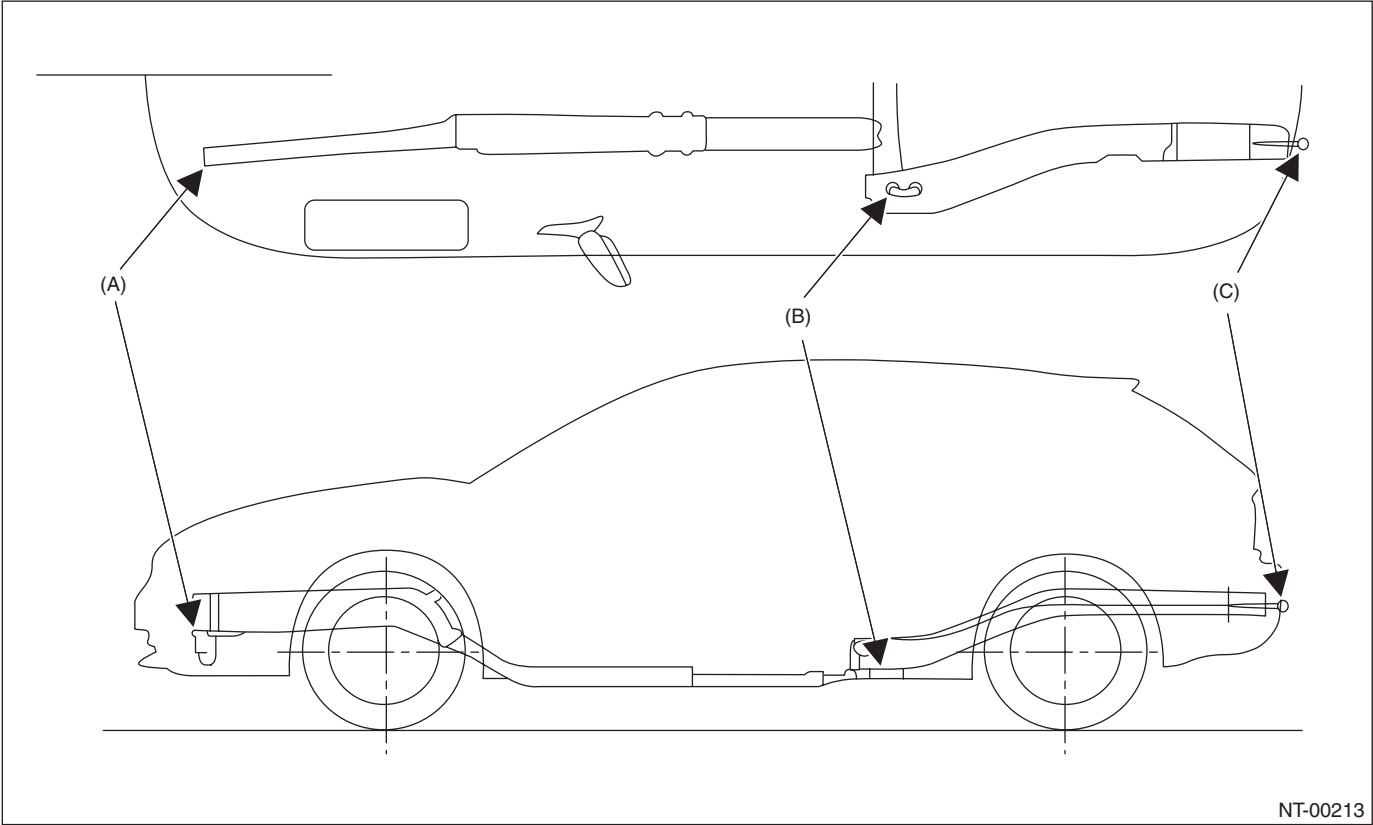

NT-00213

(A) Front tie-down hook

(B) Rear tie-down hook

(C) Eye bolt

Note

NOTE

- Tie-down direction

CAUTION:

- Pull the front and rear of the vehicle in the opposite direction, and pull the left and right of the vehicle in the same direction.
- Patterns except for the followings (recommended) are not allowed.

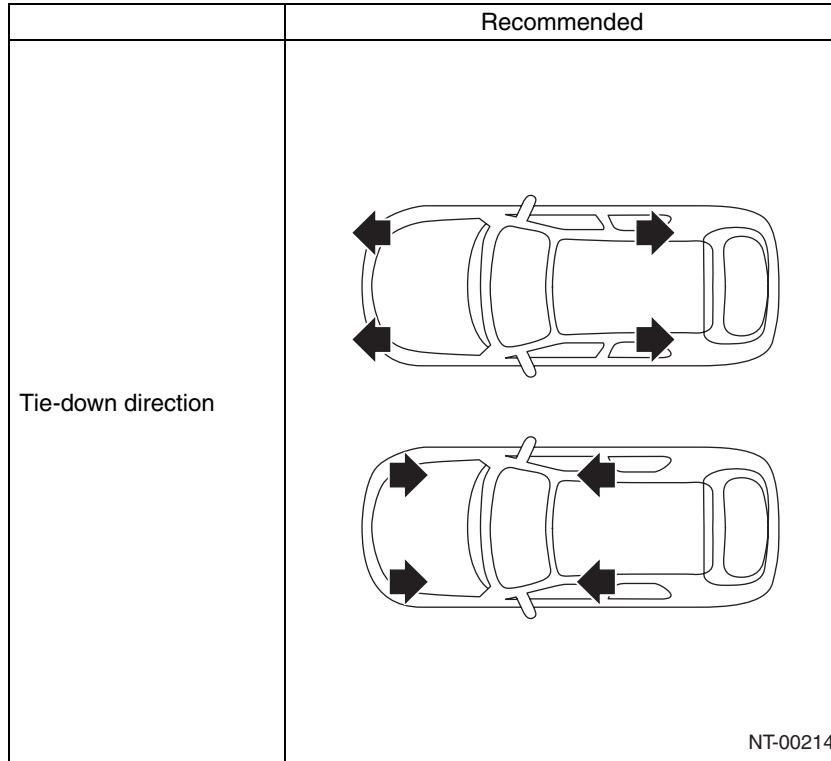

• Tie-down range

For ground transportation

CAUTION:

When the vehicle is tied down from vehicle inside, hook the hooks of tie-down chain on the rear tie-down hooks from vehicle inside. When the vehicle is tied down from vehicle outside, hook the hooks of tie-down chain on the rear tie-down hooks from vehicle outside.

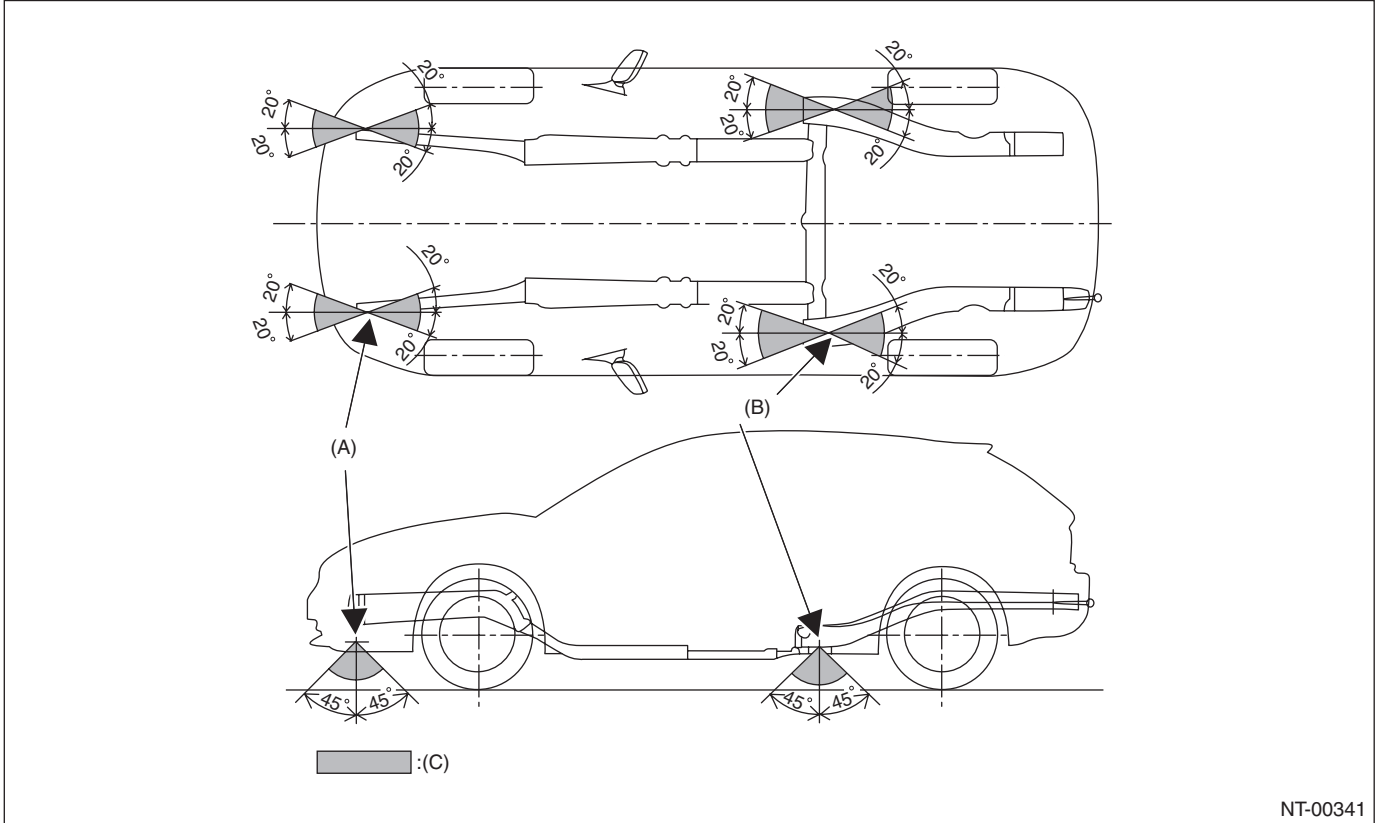

(A) Front tie-down hook

(B) Rear tie-down hook

(C) Chain pulling range at tie-down condition

Note

NOTE

For sea transportation

CAUTION:

The eye bolts are exclusively used for towing and sea transportation tie-down, and do not use them for ground and freight transportation.

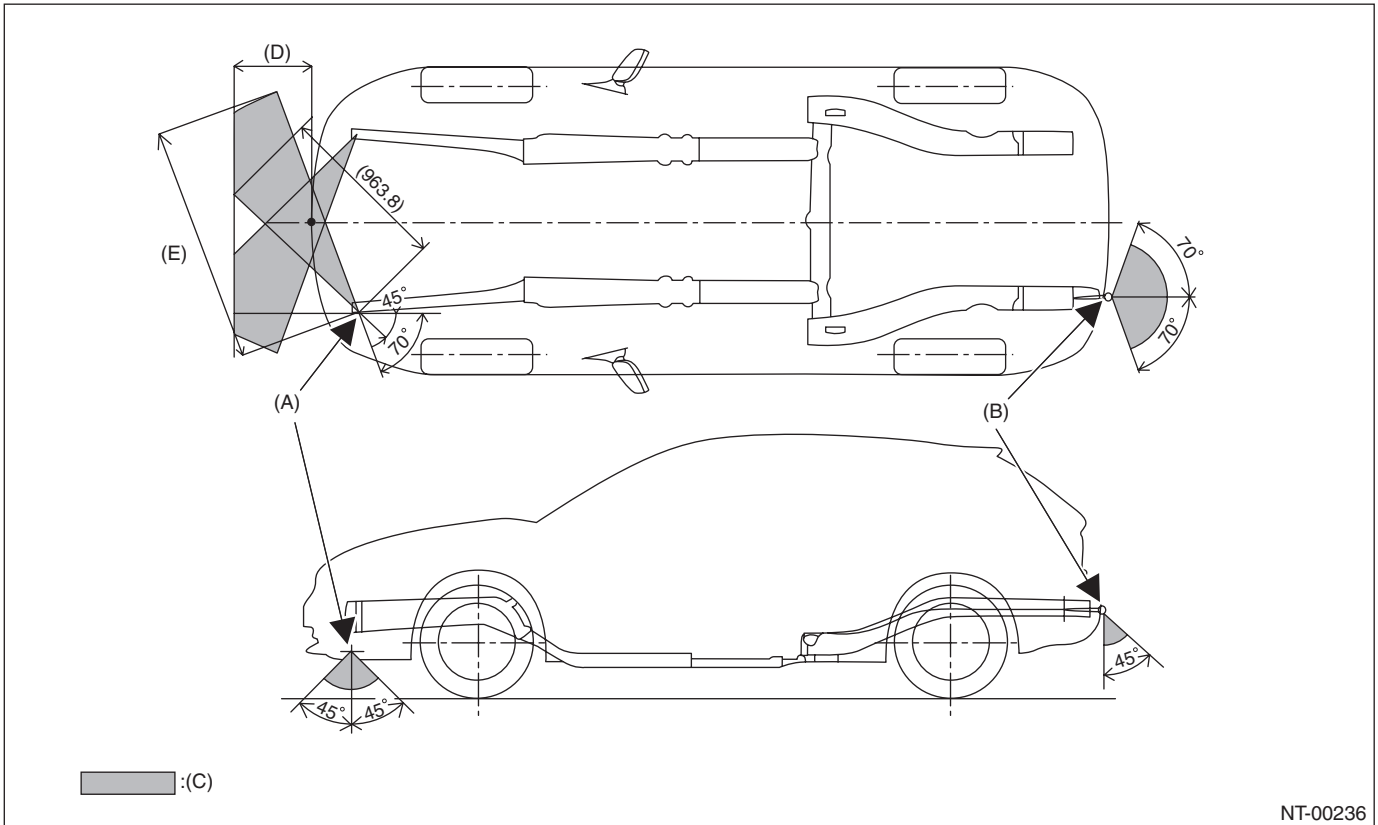

- | | | |
|-------------------------|---|------------------------|
| (A) Front tie-down hook | (C) Chain pulling range at tie-down condition | (E) 1,320 mm (52.0 in) |
| (B) Eye bolt | (D) 400 mm (15.7 in) | |

• Vehicle sinking volume at tie-down condition

CAUTION:

The vehicle sinking volume at tie-down condition should be less than 50 mm (1.97 in) and make sure to fix the vehicle securely.

Check to see if the tensions of chains or belts at tie-down condition are appropriate in the following procedures.

- 1) Before tie-down, measure the distance between the highest tire point and highest arch point at the center of wheel.
- 2) After tie-down, measure the distance between the highest tire point and highest arch point at the center of wheel.
- 3) If the distance (A) between the measured value of 1) and 2) above, is less than 50 mm (1.97 in), it is judged as OK. If the distance is 50 mm (1.97 in) or more, it is judged as NG because the tension is too high.

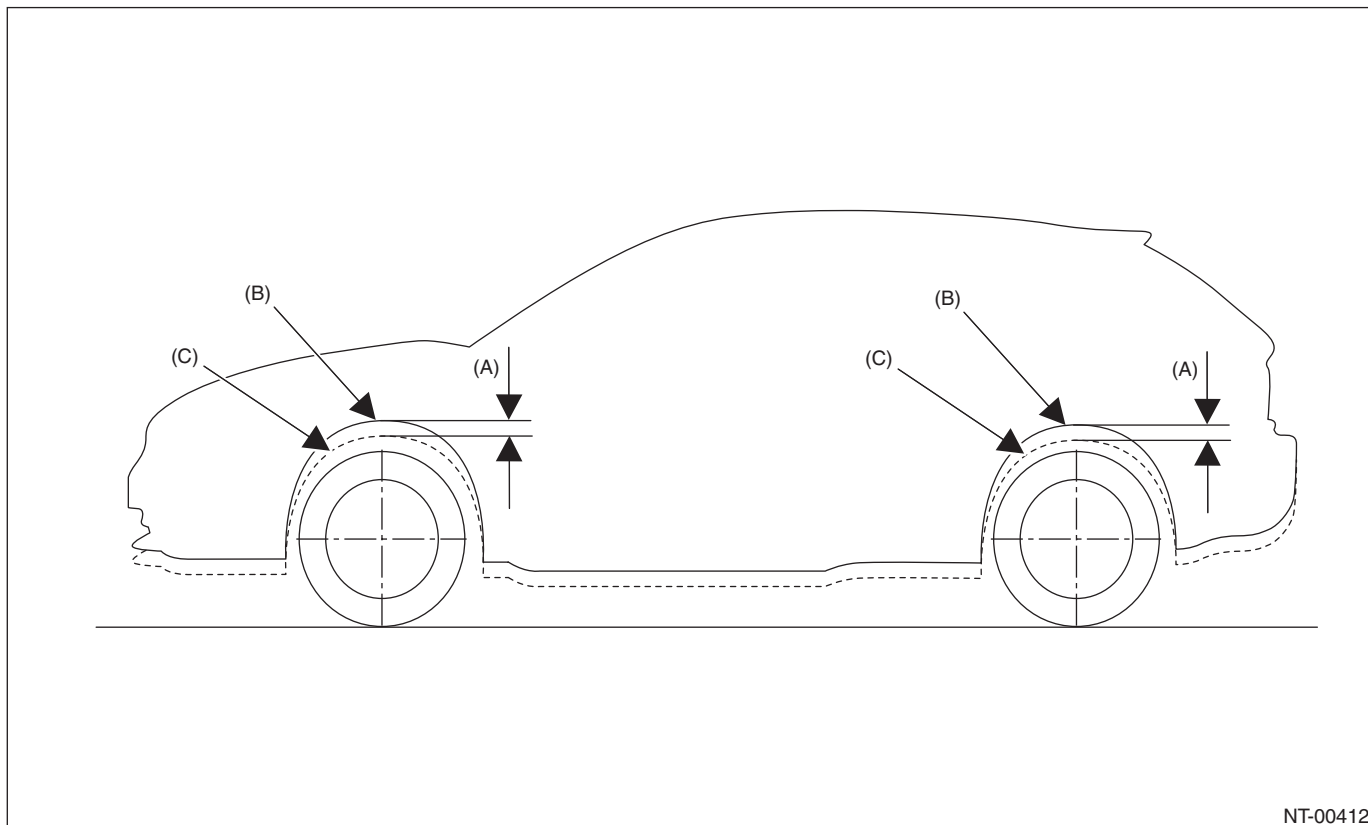

NT-00412

(B) Arch position before tie-down

(C) Arch position after tie-down

Note

NOTE

- **Notes for the use of tie-down hook**

When the vehicle is tied down from the rear side, use the holes at the rear side, and when the vehicle is tied down from the front side, use the holes at the front side.

When the vehicle is tied down from vehicle inside, hook the hooks of tie-down chain from vehicle inside, and when the vehicle is tied down from vehicle outside, hook the hooks of tie-down chain from vehicle outside.

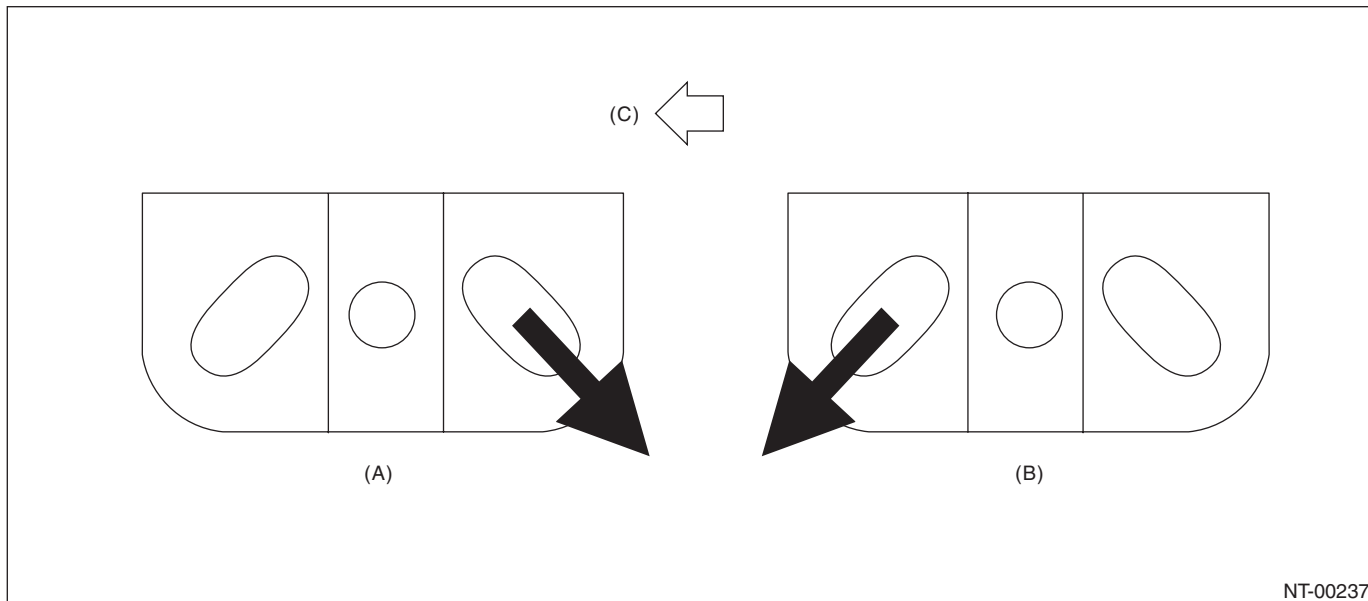

(A) When the vehicle is tied down towards the rear side

(B) When the vehicle is tied down towards the front side

(C) Vehicle front

11.TOWING

Avoid towing vehicles except when the vehicle cannot be driven. When towing other vehicles, pay attention to the following to prevent eye bolt or vehicle damage resulting from excessive weight.

- Do not tow other vehicles with a front tie-down hook.
- Make sure the vehicle towing is heavier than the vehicle being towed.

• Front

Remove the hook cover, and install the towing hook (eye bolt).

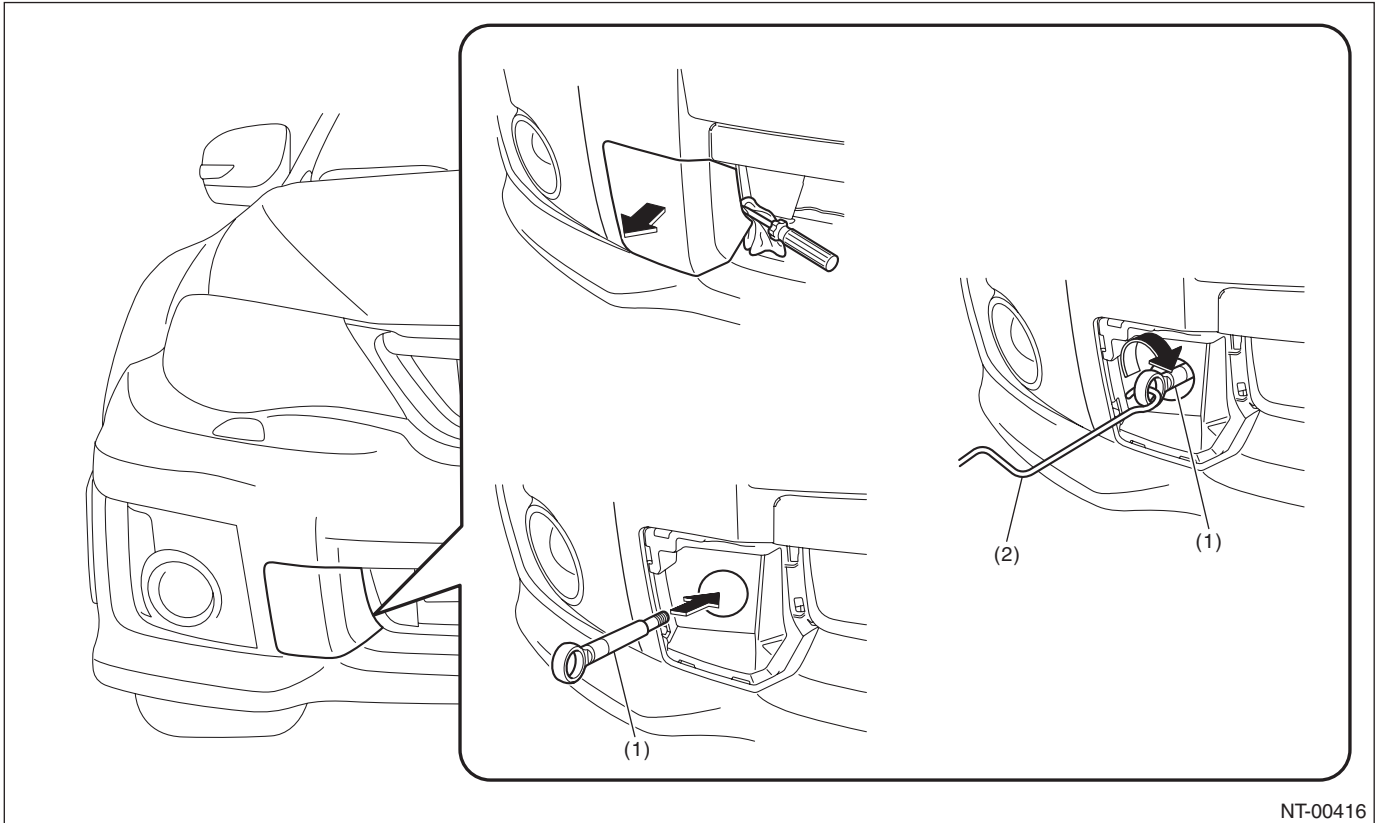

NT-00416

(1) Towing hook (eyebolt)

(2) Jack handle

Note

NOTE

• Rear

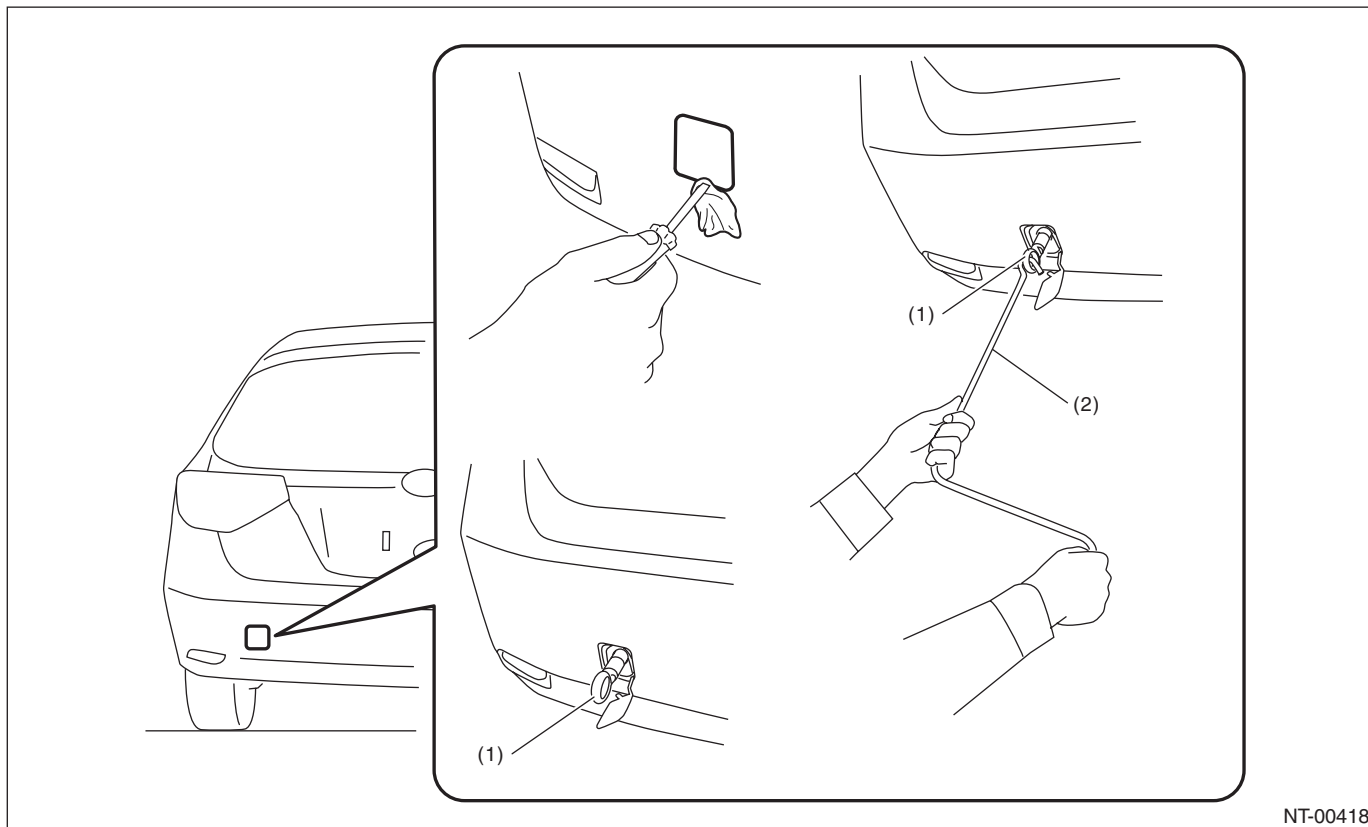

NT-00418

(1) Towing hook (eyebolt)

(2) Jack handle

CAUTION:

When tightening the eye bolt using a wheel wrench, be careful not to scratch the bumper.

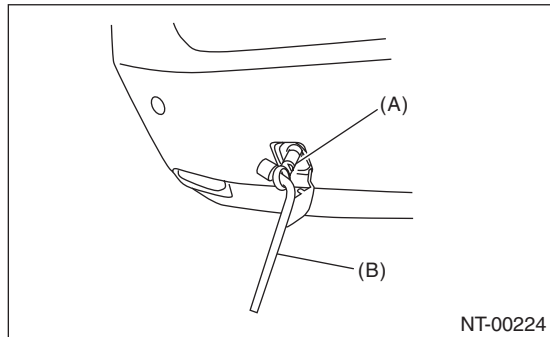



NT-00224

(A) Towing hook (eyebolt)

(B) Wheel wrench

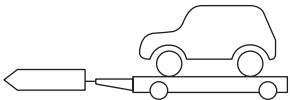
Precautions

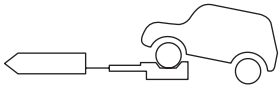
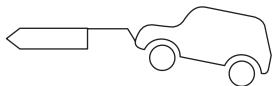
Towing	Precautions	AWD
		MT
Lifting up four wheels (On a trailer)  NT-00023	Towing the vehicle after lifting up all four wheels is a basic rule for AWD model. CAUTION: When carrying the vehicle onto a car carrier truck, refer to "LOADING ONTO CAR CARRIER TRUCK". <Ref. to NT-17, LOADING ONTO CAR CARRIER TRUCK, NOTE, Note.>	○
Rope  NT-00024	Check if both front and rear wheels are rotated normally.	○
Raising the front wheels  NT-00025	Prohibited for full-time AWD model.	×
Lifting up the front wheels  NT-00026	Prohibited, due to damage on bumper, front grille, etc.	×

○ mark: OK, × mark: Prohibited

Note

NOTE

CAUTION:

- Place the shift lever in “N” position during towing.
- Do not lift up the rear wheels to avoid unsteady rotation.
- Turn the ignition key to “ACC”, then check the steering wheel moves freely.
- Release the parking brake to avoid tire dragging.
- Since the power steering does not work, be careful for the heavy steering effort. (When engine is stopped)
- Since the servo brake does not work, be careful that the brake is not applied effectively. (When engine is stopped)
- In case of the malfunction of internal transmission or drive system, lift up four wheels (on a trailer) for towing.
- Do not use the towing hook (eye bolt) except when towing.
- Make sure to detach the towing hook (eye bolt) after towing. If it remains attached, airbag may not operate properly when receiving a shock. And it may also affect the crash performance of the vehicle.

12.LOADING ONTO CAR CARRIER TRUCK

When carrying the vehicle onto a car carrier truck, observe the following precautions.

CAUTION:

- When carrying the vehicle onto a car carrier truck, perform the operation being careful with the gap between the height of the carrier's floor and the vehicle lower side because of little clearance under the front bumper.

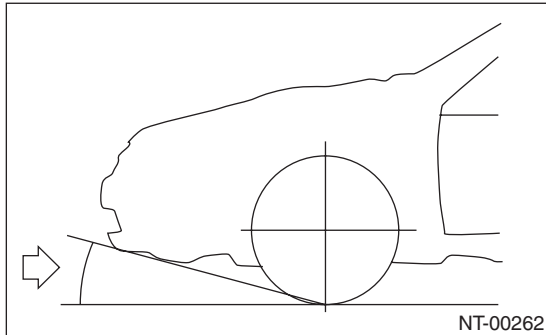

- Use a supporting board (rubber) where the clearance is too small.
- Perform the operation being careful with the position shown in the figure below.

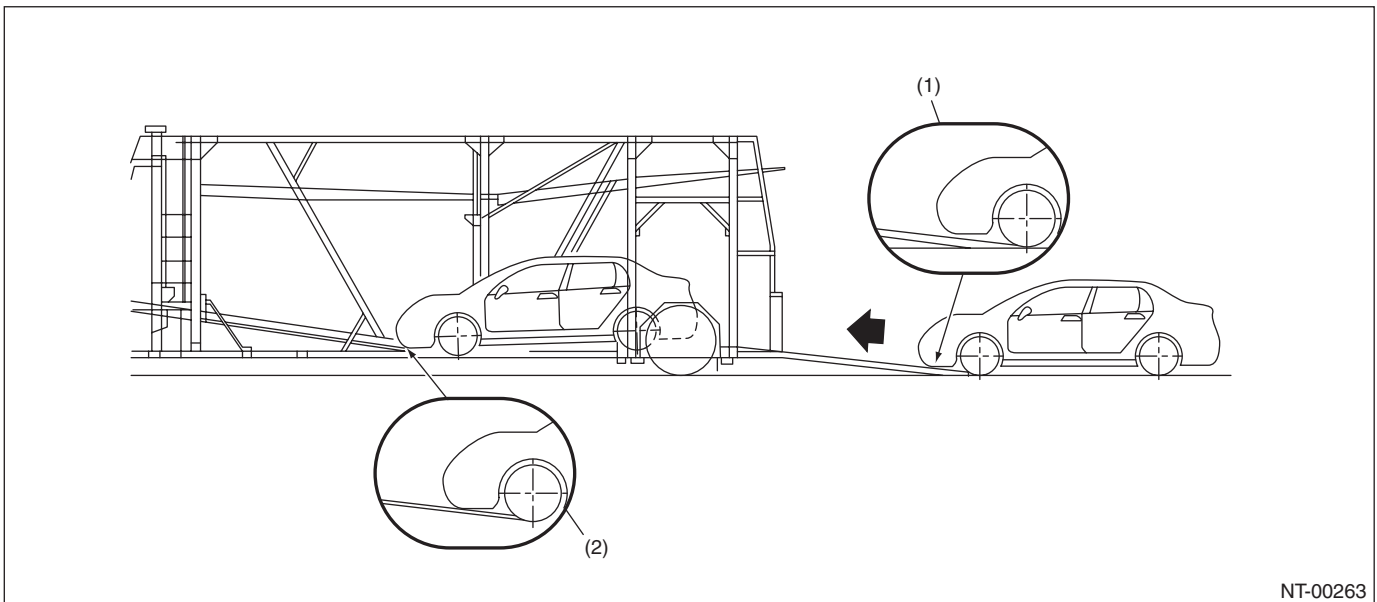

(1) Use a supporting board (rubber) to ensure clearance from the ramp.

(2) Before carrying the vehicle completely, lower the lower center floor until it is level to make clearance.

Before lowering the vehicle from the carrier car, perform the following operations.

CAUTION:

Always perform the following operations before lowering the vehicle from the carrier car. Otherwise, the power unit will rotate reversely, which may cause the damage to the engine, vacuum pump, and transmission.

1) Start the engine.

2) Set the transmission shift position into driving direction of the vehicle. (When the vehicle drives forward, do not set the transmission into R range. When the vehicle drives rearward, do not set the transmission into 1 — 6 speed.)

CAUTION:

Be sure to perform 2) mentioned above even if the engine cannot be started in some reasons.

Note

NOTE

13.FRONT HOOD DAMPER STAY

1) Always perform works such as inspections and maintenance with both damper stays attached.

CAUTION:

- At the inspection and general maintenance, do not detach the damper stays.

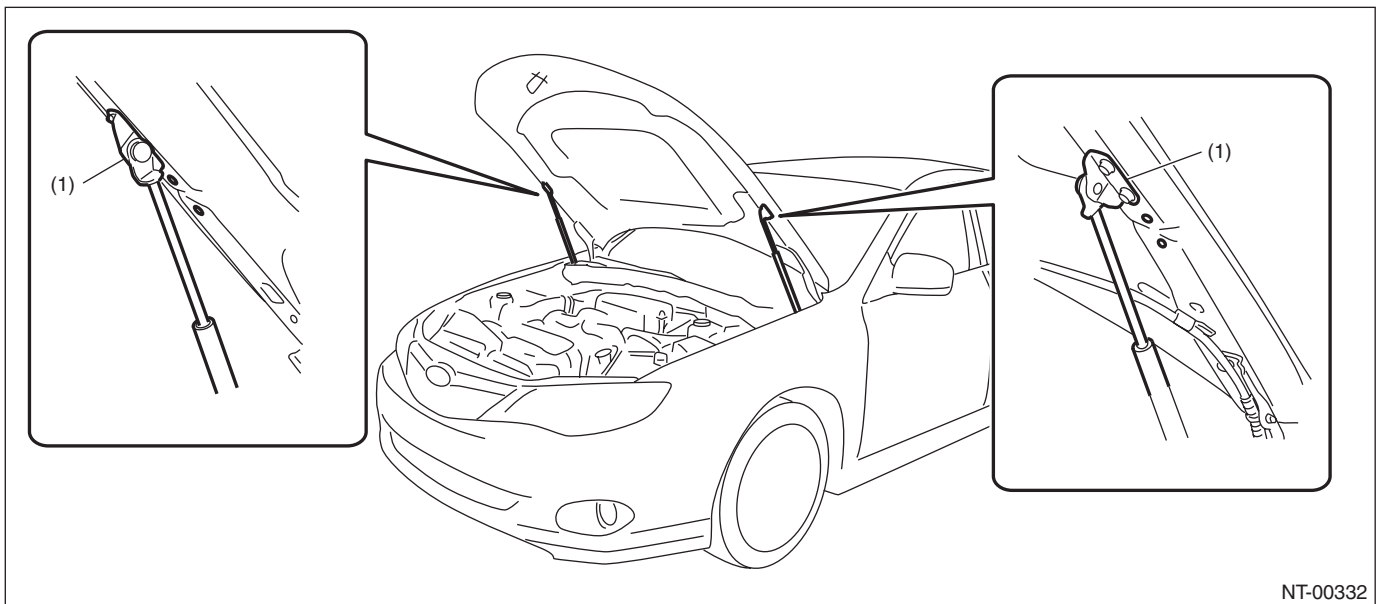

NT-00332

(1) Normal attached position

2) When wider hood opening is necessary, set the damper stay below as shown in the figure.

Tightening torque:

<Ref. to EB-8, FRONT HOOD, COMPONENT, General Description.>

CAUTION:

- Always perform works such as inspections and maintenance with both damper stays attached.
- Do not leave one side of damper stay removed.
- The hood cannot be closed with the hood damper on the full open side. When it is necessary to close, tie the hood striker and the radiator panel with a string etc. to fix them.
- After work, set the damper stays back to the normal position and tighten the bolts to the specified torque.

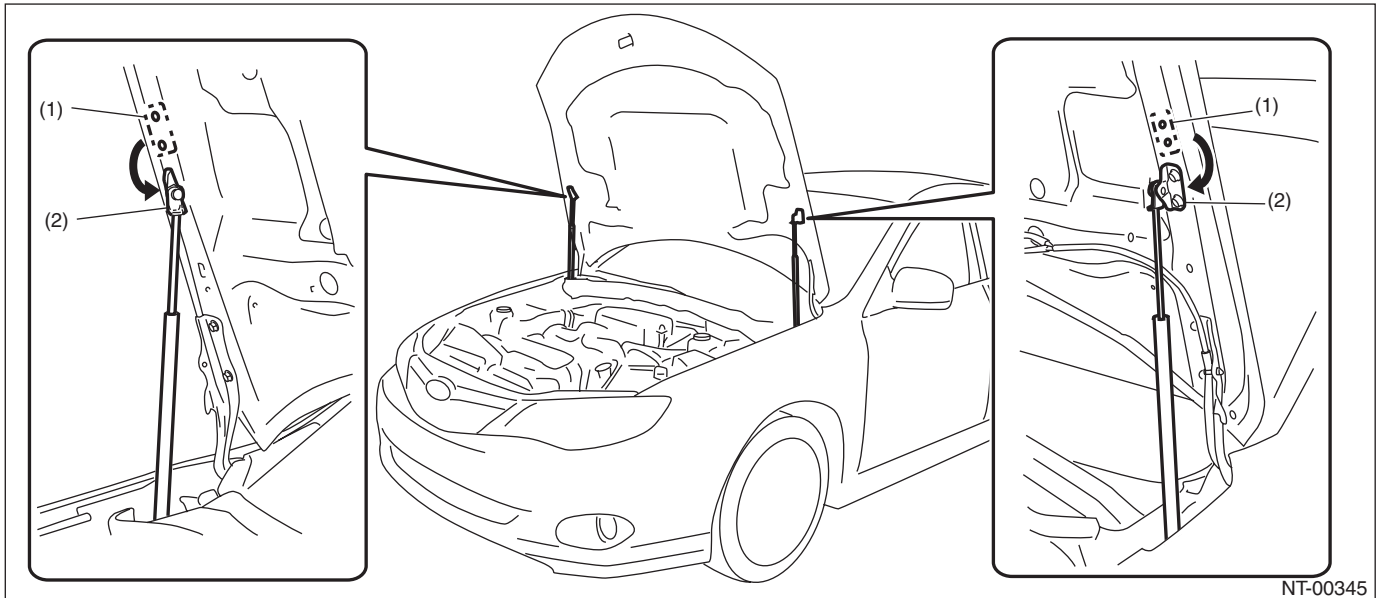

(1) Normal attached position

(2) Installation position at full open

14. TRAINING

For an information about training, contact a dealer or agent.

15. GENERAL SCAN TOOL

Using general scan tools will greatly improve the efficiency of repairing engine electronic controls. Subaru Select Monitor can be used to diagnose the engine, VDC and other electronically controlled parts.

IDENTIFICATION

ID

	Page
1. Identification	2



Identification

IDENTIFICATION

1. Identification

A: IDENTIFICATION

1. IDENTIFICATION NUMBER & LABEL LOCATIONS

The V.I.N. (Vehicle Identification Numbers) is used to classify the vehicle.

- POSITIONING OF THE LABEL FOR IDENTIFICATION

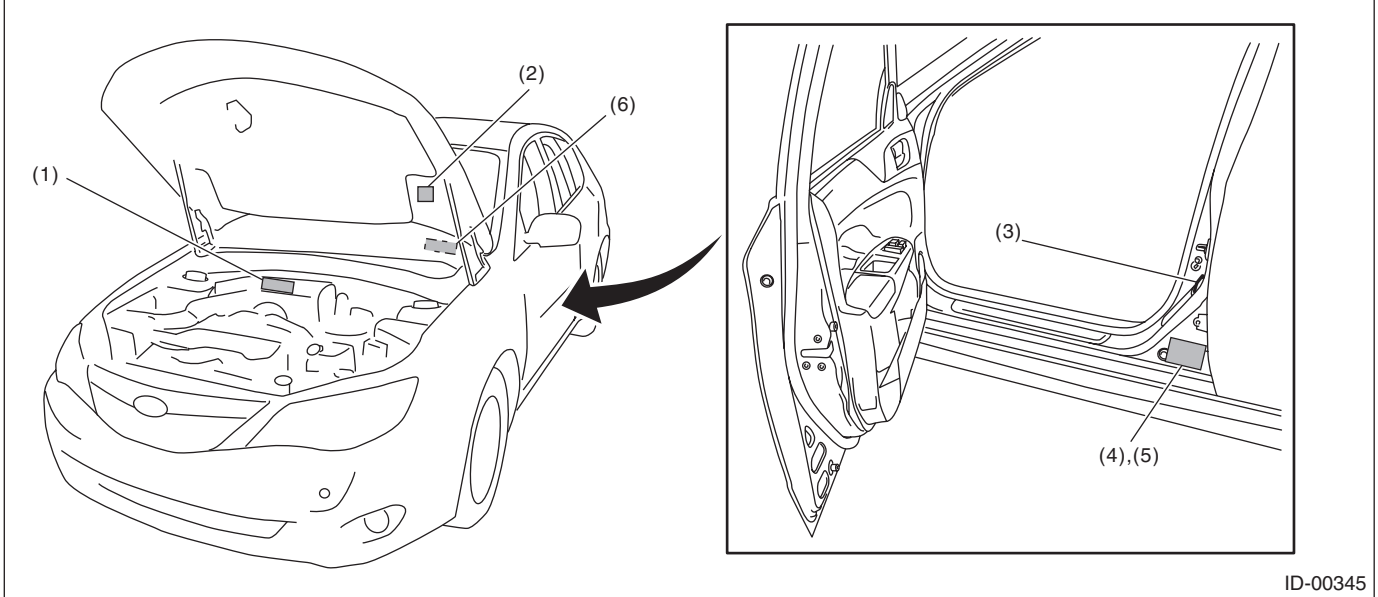

(1) Vehicle identification number (V.I.N.)

(2) Emission control label

(3) Tire inflation pressure label

(4) MVSS label (Apply on the left side of center pillar outer)

(5) Model number label (Apply on the right side of center pillar outer)

(6) Vehicle identification number (V.I.N. PLATE)

• **ENGINE**

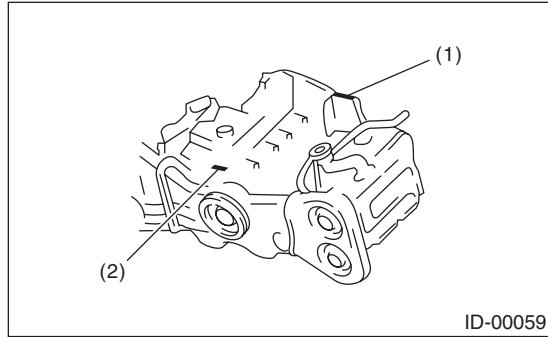

- (1) Engine serial number
- (2) Engine type (casting) crankcase upper side

ID-00059

• **REAR DIFFERENTIAL**

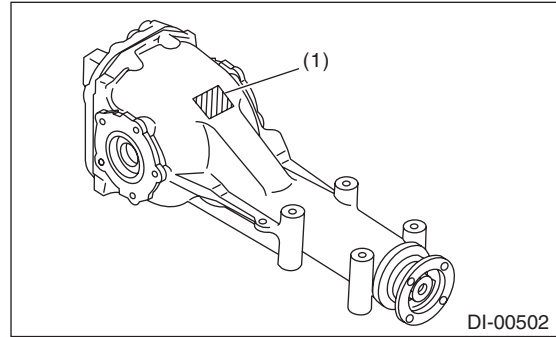

- (1) Identification (white paint)

DI-00502

• **MANUAL TRANSMISSION**

6MT

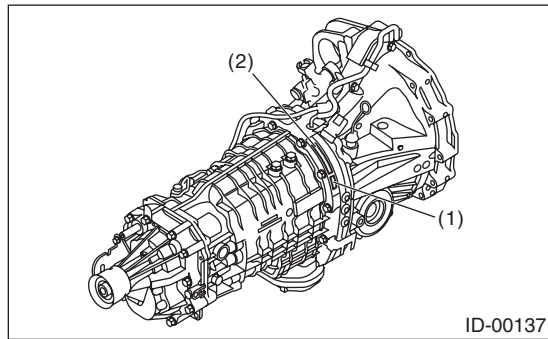

- (1) Transmission serial No.
- (2) MT type label

ID-00137

5MT

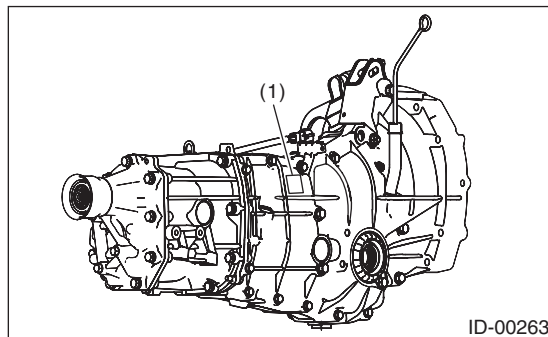

- (1) MT type and transmission serial number label

ID-00263

• **MODEL NUMBER LABEL**



ID-00223

• **MVSS LABEL**

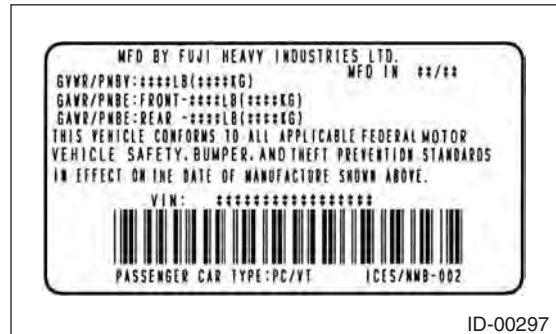

ID-00297

Identification

IDENTIFICATION

2. MEANING OF V.I.N.

The meaning of the V.I.N. is as follows:

]JF1GR8H6XDL200001[

The starting and ending brackets (] [) are stop marks.

Digits	Code	Meaning	Details
1 — 3	JF1	Manufacturer body area	JF1: Passenger car, FHI made
4	G	Car line	G: IMPREZA
5	R	Body type	V: 4 door wide body R: 5 door wide body
6	8	Displacement	7: 2.5 L AWD turbo 8: 2.5 L AWD high power turbo
7	H	Grade	E: WRX F: WRX-S G: SE H: STI J: STI-S
8	6	Restraint	6: Manual belts, dual airbag, side airbag, curtain airbag
9	X	Check digit	0 — 9 & X
10	D	Model year	D: 2013MY
11	L	Transmission type	G: Full-time AWD single range 5MT L: Full-time AWD 6MT
12 — 17	200001	Serial number	002001 — 199999: 4 door 200001 — 399999: 5 door

3. MODEL NUMBER LABEL

The model number label indicates: the applied model, the option code, the trim code, the engine type, the transmission type, and the exterior color code. This information is helpful when placing orders for parts.

GRFFYEH

Digits	Code	Meaning	Details
1	G	Series	G: IMPREZA
2	R	Body type	V: 4 door wide body R: 5 door wide body
3	F	Total engine displacement Drive system Suspension system	E: 2.5 L AWD turbo F: 2.5 L AWD high power turbo
4	F	Model year	F: 2013MY
5	Y	Destination	Y: U.S., Canada
6	E	Grade	E: STI F: WRX G: WRX-S T: SE V: STI-S
7	H	Transmission, fuel feed system	D: MFI turbo 5MT AWD H: MFI High power turbo 6MT AWD

The engine and transmission type are as follows.

Engine

EJ257BG6LB

Digits	Code	Meaning	Details
1 and 2	EJ	Engine type symbol	EJ: 4 cylinder
3 and 4	25	Displacement	25: 2.5 L
5	7	Fuel feed device	5: MFI-Turbo 7: MFI High power turbo
6	B	Exhaust regulations	B: U.S. (FED, CAL)
7	G	Mounted transmission	E: 5MT G: 6MT
8 — 10	6LB	Detailed specifications	Used when ordering parts. For details, refer to the parts catalog.

Transmission (MT)

TY856UW1MA

Digits	Code	Meaning	Details
1	T	Transmission	T: Transmission
2	Y	Transmission system	Y: Full-time AWD MT center differential
3 and 4	85	Distance between gear center	75: Between main shaft and drive pinion 85: Between main shaft and drive pinion
5	6	Classification	6: 6MT 8: 5MT
6	U	Transmission specifications	U: Full-time AWD single range 6MT with driver's control center differential V: Full-time AWD single range 5MT with viscous coupling center differential
7	W	Mounted engine	G: 2.5 L DOHC high power turbo W: 2.5 L DOHC turbo
8 — 10	1MA	Detailed specifications	Used when ordering parts. For details, refer to the parts catalog.

Identification

IDENTIFICATION

Rear differential

Code	Reduction gear ratio	LSD
H3	3.545	Torsen
B2	3.900	None

Option code

MH

- 1-digit number

OP code	C	M	O	Q	R	S	T	U	V	3	4	5
18 in Tire & Aluminum wheel (BBS)	—	—	—	—	○	○	—	○	—	○	—	—
Navigation	—	—	—	○	—	—	—	○	○	○	—	○
Sunroof	○	—	○	○	—	○	—	○	—	—	○	○
Side airbag	○	○	○	○	○	○	○	○	○	○	○	○
Curtain airbag	○	○	○	○	○	○	○	○	○	○	○	○
HID headlight	—	○	○	○	○	○	—	○	○	○	—	—
Front fog light	○	—	○	○	○	○	—	○	—	○	○	○
Satellite tuner	○	—	—	—	—	—	—	—	—	—	—	—

- 2-digit number

OP code	H	R
Genuine leather seat	○	—
Seat heater	○	○
Cold weather package	○	○

RECOMMENDED MATERIALS

RM

	Page
1. Recommended Materials	2

