



Substation Automation Systems

Digital transformation for substation automation. Leading substation development for over 110 years.



- Maximum safety, efficiency and reliability for local and remote control and monitoring.
- Flexible functionality and system architecture to cope with changing requirements, philosophies and technologies.
- Cyber security is an essential feature of ABB's products and systems

ABB's modular Substation Automation Systems are designed for maximum safety, efficiency and reliability for local and remote control and monitoring of your substation. ABB offers a smart choice for new stations, retrofit and migration projects.

Invest today in the ultimate and most efficient strategy to build substation automation systems.

Table of contents

004–005	Leading substation development.
006–007	The highlights of ABB’s Substation Automation.
008–009	The offering.
010–011	Modular, scalable architecture for substation automation solutions.
012–013	IEC 61850 station bus topologies.
014–017	Far beyond station control.
018–019	A comprehensive portfolio.
020	From specification to system delivery and service.
022	Cyber security protection over system lifecycles.
023–024	ABB Power Grids service.
026–027	ABB Digital Substation.

Leading substation development for over 110 years.

Dependable substation performance is a key for grid reliability. ABB has been designing and building substations since the 1900s.

2017

ABB Ability™ launched

Enabling end-to-end digitalization from the process level to the control room and beyond.

2004

World's first IEC 61850 multi-vendor substation automation.

ABB has supplied thousands of products and systems for new and retrofit projects.

1995

Development and verification

of the IEC 61850 substation communication standards.

1980s

Innovation

in substation automation replaced conventional protection and control systems with numerical ones.

In the late 1980s, ABB innovations in substation automation replaced conventional protection and control systems with numerical ones. ABB is also dedicated to the development of industry standards, including those used in substation automation. ABB has been a driving force in the development and verification of the IEC 61850 substation communications standard since 1995. Since implementing the world's very first IEC 61850 multi-vendor substation automation system in 2004, ABB has supplied thousands of products and systems for new and retrofit projects. ABB is the world's leading supplier of air-insulated, gas-insulated and hybrid switchgear and substations, utility communication networks as well as IEC 61850 substation automation, protection and control solutions and systems.

Six facts about the modular substation automation systems.

1

—
Over 15,000 IEC 61850 Substation Automation Systems have been installed worldwide.

2

—
More than 30,000 Station HMI and Station Gateway/RTU have been delivered worldwide.

3

—
More than 35 IEC 61860-9-2 Digital Substation projects have been installed worldwide.

4

—
ABB's IEC 61850-accredited system verification center provides a 24x7 real-life system testing environment.

5

—
ABB's Grid Automation systems and Services are present in more than 40 countries.

6

—
ABB developed the world's first IEC 61850 Edition 2 conformance-tested system engineering tool in 2016.



The highlights of ABB's Substation Automation.

Complete solutions for efficient protection, automation, control and monitoring.

ABB's substation protection, control, automation and monitoring solutions are designed for maximum safety, efficiency and reliability – for all types of substations.

- **Complete portfolio** of inter-operable systems, products and tools, fully compliant with IEC 61850.
- **Flexible functionality and system architecture** to cope with changing requirements, philosophies and technologies.
- **Field-proven functionality and hardware**, as well as innovative technologies, ensure best solutions for all substation applications.
- **High availability and fast access** to revise information from anywhere in the system to shorten response times and reduce the duration of outages.
- **Cyber security** is an essential feature of ABB's products and systems. It is embedded from the earliest stages of the design process, through development and project execution, to ensure full functionality, without compromising reliability and interoperability.
- **Open system design** allows easy integration of additional components beyond protection and control such as transformer monitoring, metering, sub-RTUs and other third-party components.
- **Modular and scalable architecture** for easy system extension safeguards initial investment. An existing system can be extended at any time from a functional and system size perspective. For example, you can enhance a basic system by adding an advanced historian or expand from a SCADA to DMS functions.
- **Robust and highly reliable** solutions through use of substation hardened component
- **Optimal solution for migration.** Replace traditional RTU with ABB SAS and gradually extend and migrate from the conventional to a modern IEC61850-based solution.

—

ABB's world-class protection, control and monitoring solutions ensure reliable power transmission and distribution. Our IEC 61850-compliant product portfolio provides you with open, future-proof and flexible system architecture. With ABB's long experience in the field, our full scope of services and global support network, we are a leader in substation automation systems.

Best-in-class applications to protect and control your power system.

With our unrivaled expertise and global experience in substation automation, protection and control systems, you can be sure of getting the best solutions for your applications. We offer field-proven protection solutions for generators, busbars, lines, transformers, shunt reactors, capacitors and motors, as well as station protection systems with decentralized structure and functional integration.



The offering.

01 Substation Automation Solutions

The benefits of advanced power system management require the automation of local operations and the collection, evaluation and forwarding of data on the power system status and plant condition to higher-level systems. The Substation Automation Solutions (SAS) provide remote control and monitoring functions for all kinds of substations, starting from the distribution level up to extra-high voltage substations, and are designed for maximum safety, efficiency and reliability. Incorporated in every SAS is ABB's vast expertise in IEC 61850 and proven system integration capabilities. The results are future-proof systems with interoperability for optimal lifecycle management and low lifecycle cost.

The ABB intelligent electronic devices (IEDs) for protection and control are an integral part of the SA system. The SAS and IED together lay the foundation for all the higher-level remote functions such as advanced power system management and the monitoring of the condition of the equipment while it is in service. Station level systems are easy to use and adapt to customer specific requirements. Our scalable modular systems reflect the typical needs and availability aspects for the following range of applications.

- Transmission, sub-transmission and distribution substations
- Utilities and industries
- New installations and refurbishment of existing substations
- Gas and air insulated switchgear

02 Bay Solutions

Bay Control Solutions

The modular bay control solutions ensures maximum operator support and safety in the local control and supervision of AIS as well as GIS substations. Smart combinations of high-performance IEDs with conventional hardware elements are tailored to your philosophy and meet the highest demands on availability and reliability.

The inclusion of comprehensive protection function is as easy as the integration with any switchgear and IEC 61850-compliant substation automation system.

- Optimized bay control solutions for MV (medium voltage) to EHV (extra-high voltage) substations, e.g., packages for local or remote control
- Flexible realization of your control philosophy for AIS and GIS
- Scalable, modular hardware and functionality
- Proven functional designs based on global experience
- Efficient integration into IEC 61850-compliant system

Bay Protection Solutions

The modular bay protection solutions offers a clever way of safely realizing reliable protection schemes for all applications in new and retrofit substations. ABB's long experience and deep know-how as a global protection system supplier, field-proven functionality and hardware as well as innovative technologies are all part of the package. Short project implementation times, reduced risks and lifecycle cost as well as easy introduction of IEC 61850 into your substations are additional benefits.

- Optimized protection solutions for MV to EHV substations
- Flexible realization of your protection philosophy and schemes
- Scalable hardware and functionality
- Full use of IEC 61850 data model for efficient integration into IEC 61850-compliant systems

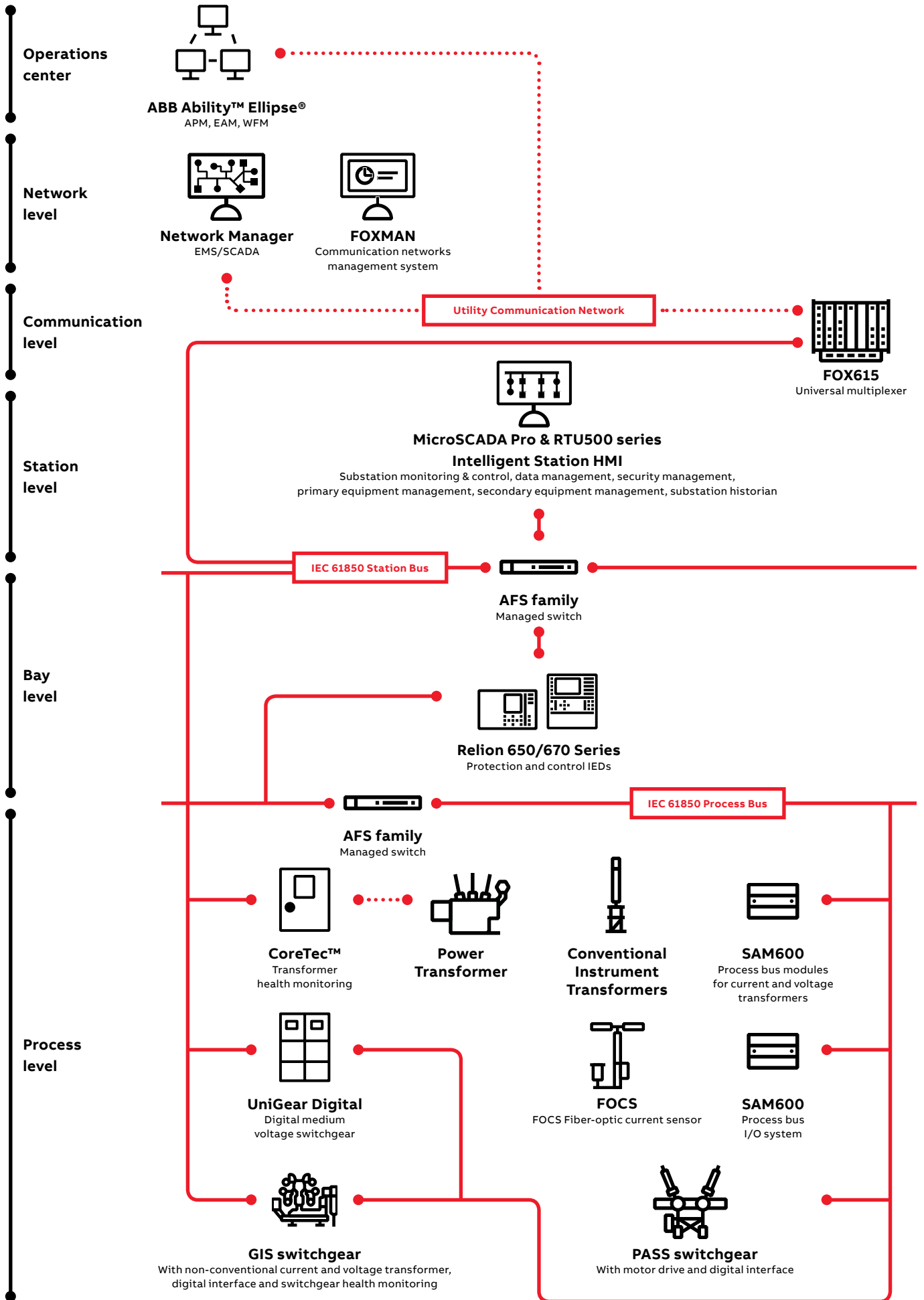

Modular, scalable architecture for substation automation solutions.

01 Basic automation solution

The compact solution for safe local control and monitoring. It features a single gateway or computer and can be upgraded at any time. The choice is yours in terms of advanced functions and/or remote control access.

Features:

- Single gateway/computer with optional HMI
- Basic monitoring and control functions

Typical applications:

- Distribution and sub-transmission

02 Enhanced automation solution

The solution for the manned substation. Single or redundant station HMIs are supplemented with an independent industrial gateway for remote control access.

Features:

- Highly reliable embedded industrial gateway for remote control access
- Single or redundant industrial station computer with HMI independent of gateway

Typical applications:

- High voltage transmission

03 Advanced automation solution

The fully redundant local and remote control solution meets even the highest availability requirements. You are assured of the continuous controllability of your substation—after all, it is of prime importance.

Features:

- Redundant, highly reliable embedded industrial gateway for remote control access
- Independent redundant industrial station computer with HMI

Typical applications:

- Extra-high voltage transmission
- Complex distribution

Options:

- Printers for event printing and hardcopy
- Engineering and operator workstations
- Single or redundant time server with integrated GPS receiver
- Network attached storage (NAS) to store data and backups
- Router and firewalls with VPN functionality
- Proxy to connect legacy protocols and I/Os to IEC 61850
- Station alarm device
- Advanced monitoring functions
- Advanced control functions

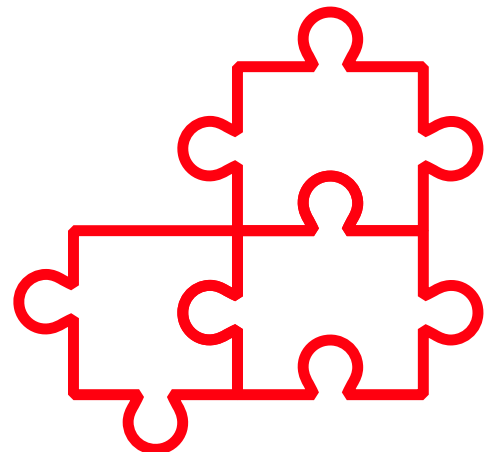

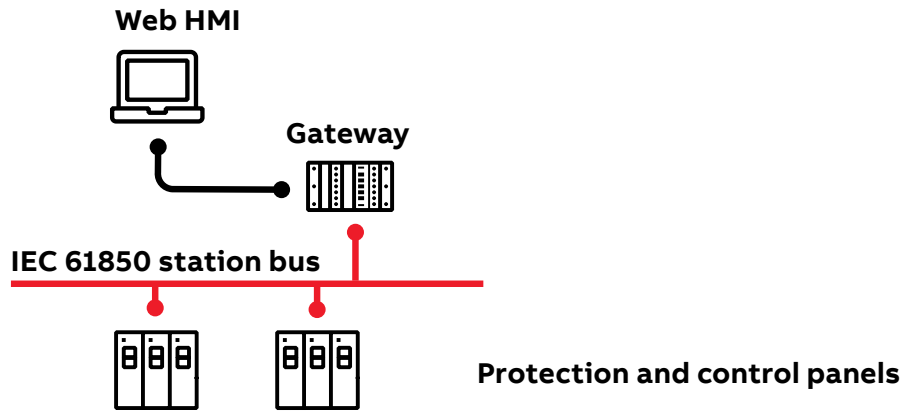

—
01
Basic automation: the all-in-one solution

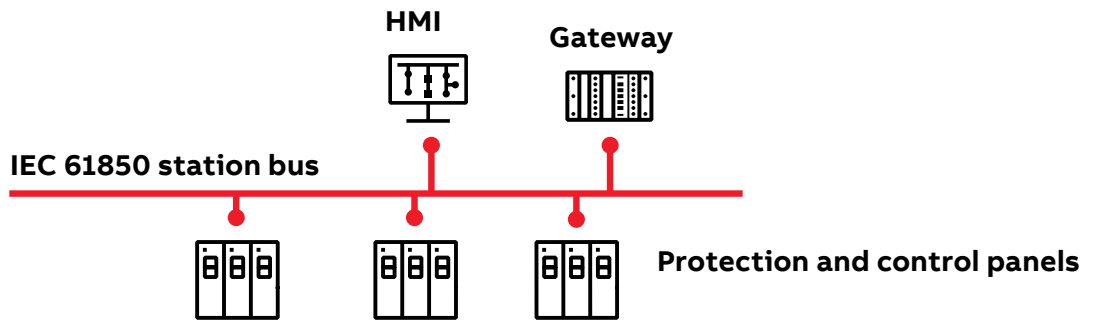

—
02
Enhanced automation: the gateway and HMI solution

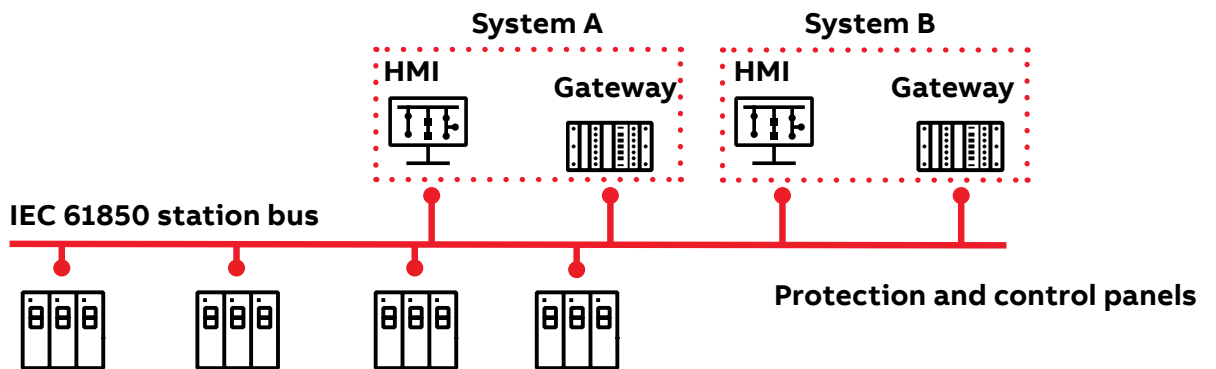

—
03
Advanced automation: the redundant solution

IEC 61850 station bus topologies.

The communication topology for the IEC 61850 station bus can be arranged in different configurations, depending on the desired network availability, the geographical arrangement of the IEDs and on the total number of IEDs in the system.

Self-healing ring (RSTP), single attached devices **RSTP: rapid spanning tree protocol**

In a self-healing ring, each Ethernet switch is connected to two, and only two, neighbor Ethernet switches to form a physical loop. The ring offers full redundancy against link failures between Ethernet switches.

The redundancy protocol RSTP ensures that frames do not circulate indefinitely, and a faulty link is typically recovered within a couple of tens milliseconds. End devices are connected with a single connection to one Ethernet switch. Depending on the physical location of the connected IEDs, Ethernet switches may be placed centrally at one location, e.g., in a dedicated communication cubicle or distributed close to the IEDs inside the same protection and control cubicles.

IEC 62439-3 HSR-based topology **HSR: highly-reliable seamless ring**

A ring structure between end devices saves wiring and Ethernet switches. Additionally, HSR provides seamless link redundancy, meaning there is no switch-over time in the event of a faulty link. Thus, the solution is well-suited for time-critical applications using GOOSE or sampled value communication.

Medium-voltage substations with typically one IED per bay or process bus are two typical applications for HSR based topologies. To connect a station computer, gateway or a single-port IED, an HSR redbox is required.

IEC 62439-3 PRP-based topology **PRP: parallel redundancy protocol**

PRP is a layer 2 redundancy protocol that provides seamless operation in case of loss of any link or Ethernet switch. PRP relies on complete duplication of the LAN. Both LANs operate in parallel and each individually can either use a star connection or a self-healing ring (RSTP) as described above. The end devices (IEDs) have to support link redundancy according PRP whereas the network is transparent. Single-port IEDs can easily be integrated with just one port connected to one LAN or, if connection to both LANs is required, using a PRP redbox.

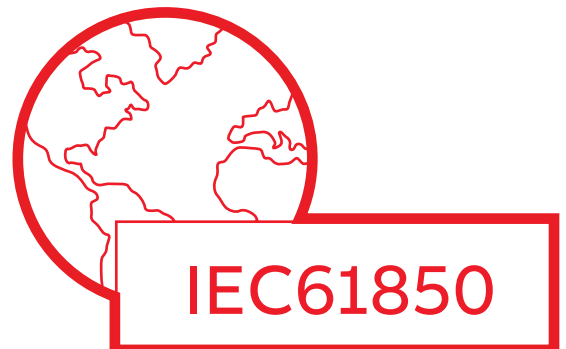

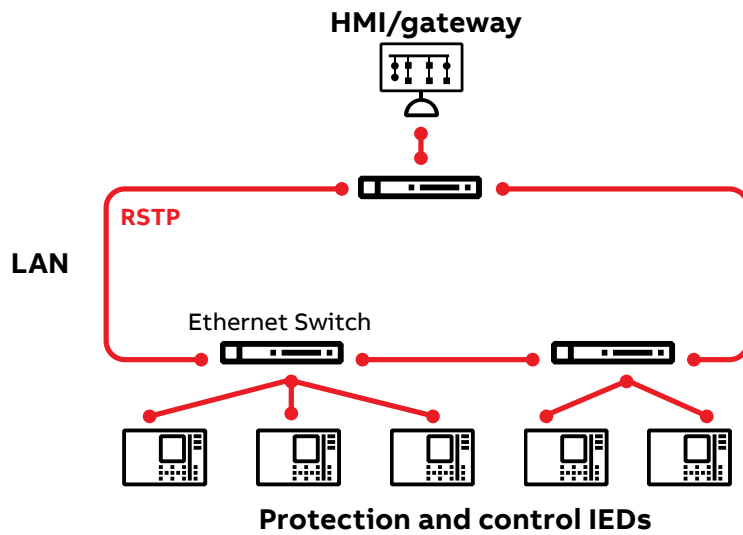

—
01
Self-healing ring (RSTP), single attached devices
RSTP: rapid spanning tree protocol

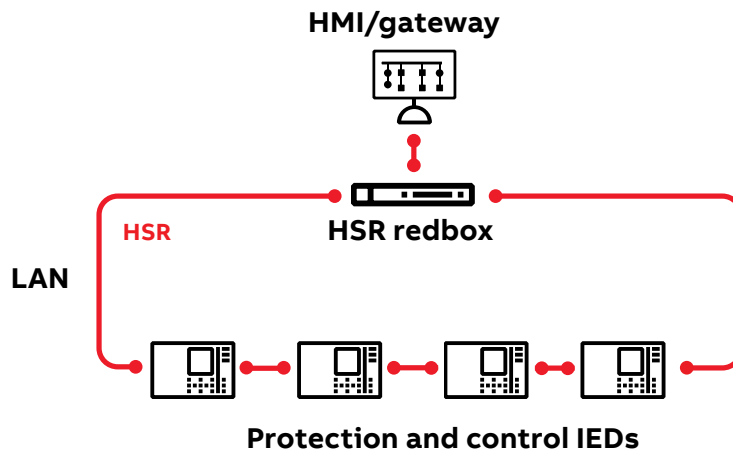

—
02
IEC 62439-3 HSR-based topology
HSR: highly-reliable seamless ring

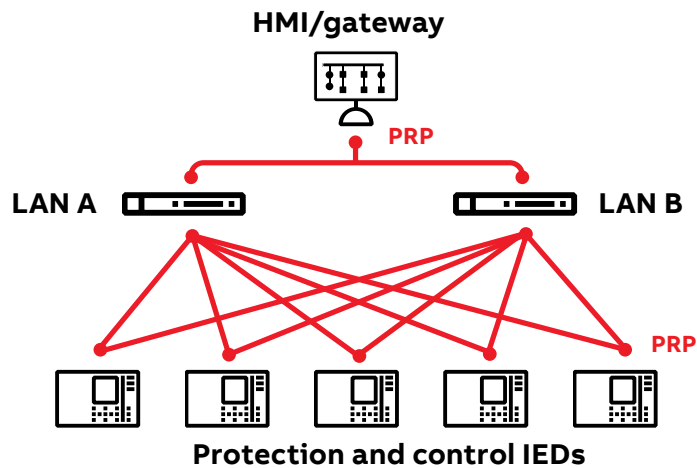

—
03
IEC 62439-3 PRP-based topology
PRP: parallel redundancy protocol

Far beyond station control.

Basic and advanced functionalities.

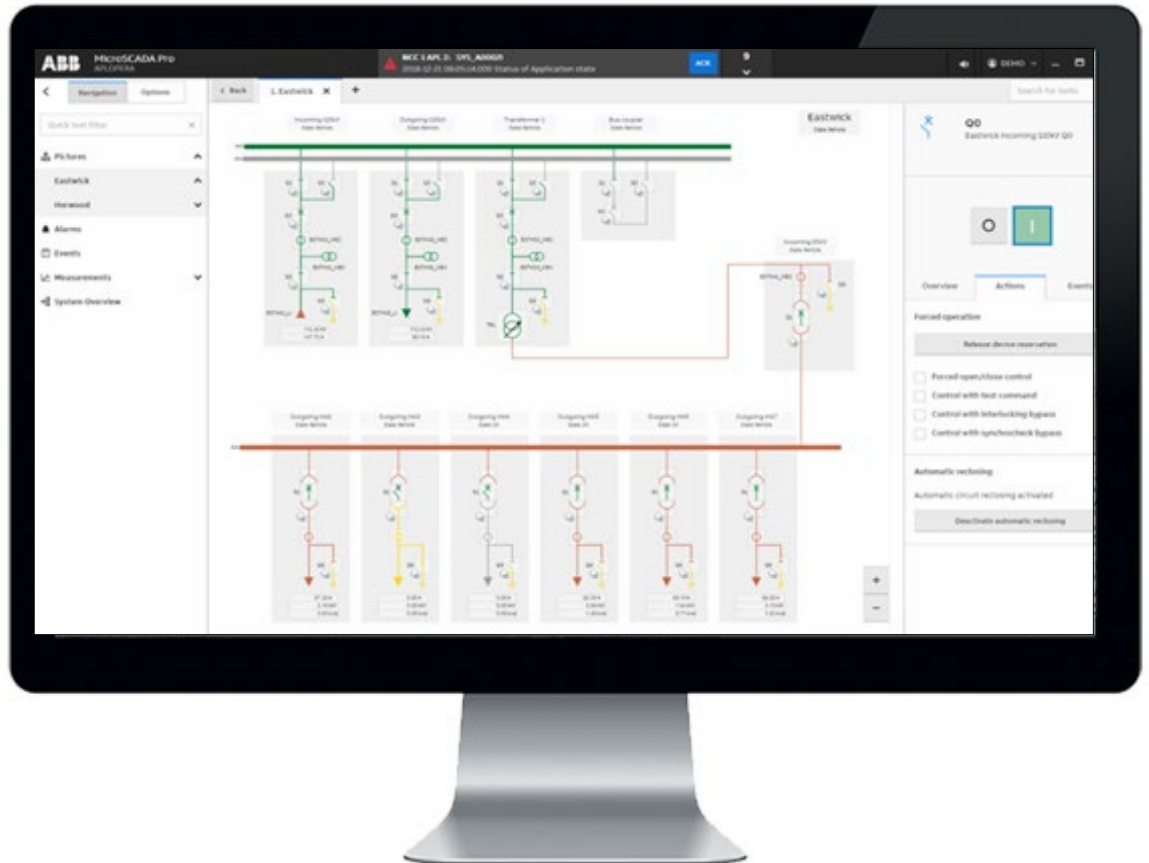

Primary equipment supervision

- Continuous monitoring of switching objects
- Display of measurements
- Access to control dialogues

Measurements

- Direct from VTs IEC, PTs ANSI and CTs
- mA- and V-Signals
- Time-tagged at bay level
- Statistics

Control

- Dialogues for switching objects and tap-changer operation
- Single and double commands
- Analogue set values

Dynamic busbar coloring

- Dynamic coloring of the different switchgear parts
- One color per power source
- Enhanced overview for complex substations

Safety checks

- Select-before-operate
- Interlocking (bay and station-wide)
- Synchroncheck
- Double-command blocking

Automatic sequences

- Execution of pre-defined switching sequences
- Safety checks (same as for switching of individual objects)
- Freely configurable sequences

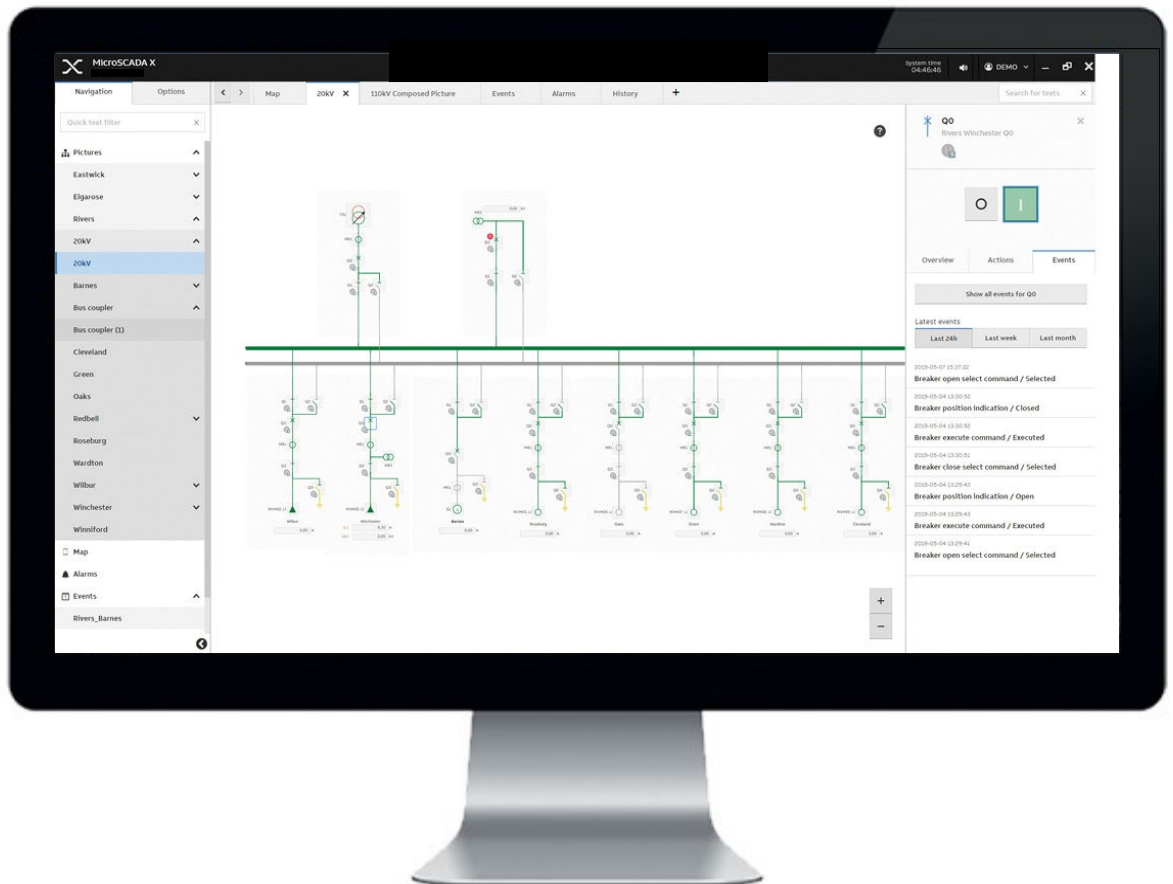

System supervision

- All bay and station level IEDs
- Auxiliary and devices (printer, etc.)
- Communication network/links

IED parameterization

- Configuration/parameter upload from IED
- Change of individual parameters or parameter sets
- Access to all IED parameters

Disturbance record upload

- Manual upload
- Automatic cyclic upload

Disturbance record analysis

- Waveform visualizations, signal vectors
- Fault location, advanced calculation
- Frequency deviation, apparent and reactive power calculation
- Automatic analysis

Far beyond station control.

Basic and advanced functionalities.

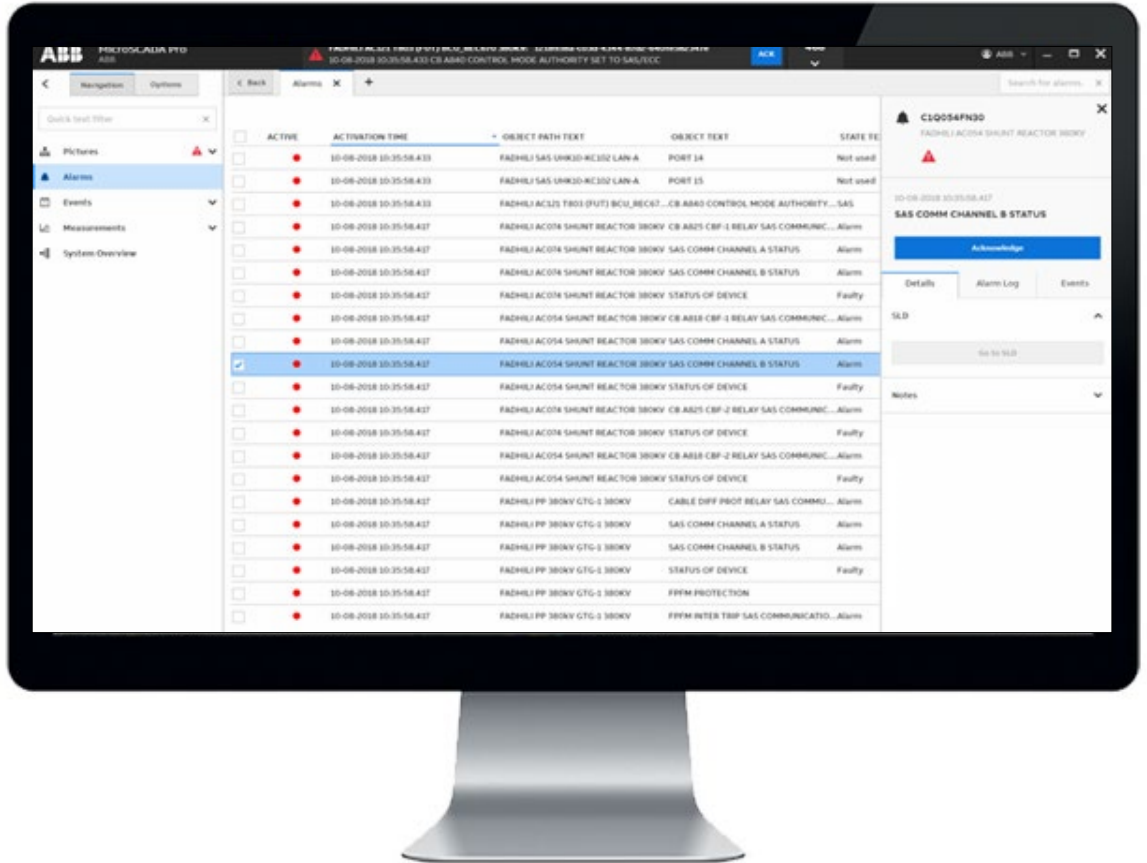

Sequence of events

- Event list
- Historical events
- Filtering function
- Export facilities

Calendar*

- Start time-related activities
- Execution of activities during a certain time period, once or repetitively
- Flexible configuration, individual and independent configuration per day

Blocking list*

- Summary display of current blocking situation in the process database
- Blocking of alarms, events, updates, control, printing and reprocessing

External alarming

- Fax, voice message
- SMS, pager system
- E-Mail

Alarms

- Alarm list (persistent/fleeting alarms)
- Alarm acknowledgment
- User-defined alarm classes
- Control of acoustic alarm

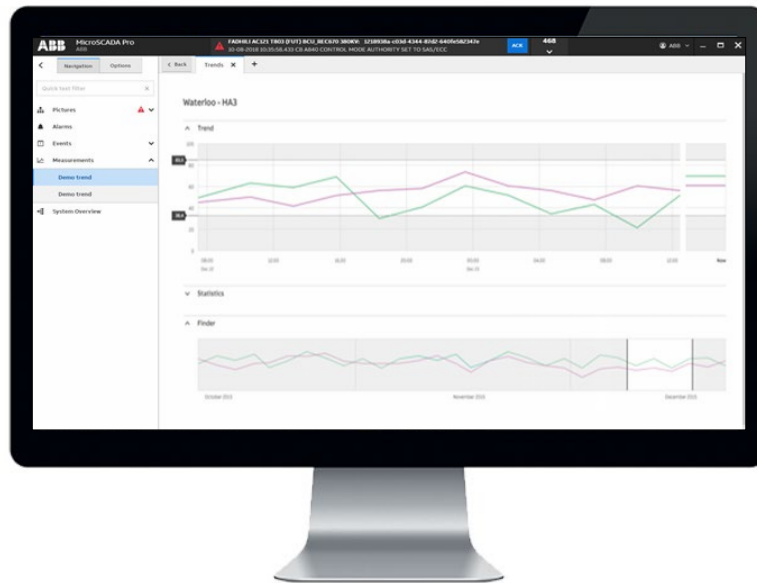

Trends

- Short-term observation and analysis
- Assignment of any process values
- Graphical or tabular representation
- Calculation formula

Measurement reports

- Statistical measurement reports stored in report database
- Hourly/daily/weekly/monthly/yearly report
- Tabular or graphical representation
- Report data in ASCII or CSV format
- Sum, mean, average, min. max.

Historian and analytics

- An view of the primary process enables facts-based decision making
- Collect and store various types of data in a database designed to thousands of values over longer time periods in an accurate and reliable way
- Assessment for fault analysis such as as routine/filter, fault analysis, report, data correlation



Service guidance such as trip counter table

- Maintenance information for CBs
- Numbers of opening operations
- Accumulated magnitude of the trip currents

Load shedding

- Control at bay level, configuration and supervision at station level
- Static load shedding
- Adaptive load shedding

High-speed busbar transfer

- Change-over of motor-feeding busbar from normal to backup supply and vice versa
- Control at bay level, configuration and supervision at station level

* Not available in basic

A comprehensive portfolio.

Robust and proven solutions.

From the control center to primary equipment, ABB delivers a comprehensive portfolio of products, systems and services for substation automation. Our offering is future-proof, equipped with the latest cyber security features, compliant with international standards and robust enough to perform well in the harshest environments. ABB is the trusted partner for a complete substation automation portfolio and more.



01



02

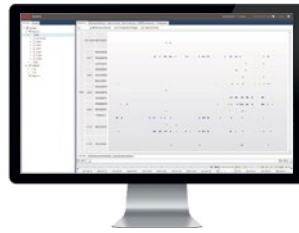

03



04



05



06

01 MicroSCADA Pro SYS600

This compact system delivers complete functionality for real-time monitoring and control of primary and secondary equipment. Advanced automation functions, extensive communication support, and long-term data logging give you ultimate insight and control of your networks.

04 MicroSCADA Pro SYS600C

Robust and compact, it offers an ideal solution for harsh and demanding environments in both transmission and distribution substations. Depend on it whenever real-time process information as well as state-of-the-art monitoring and control capabilities are crucial.

02 MicroSCADA Pro Historian

Collects and stores various types of data in a database designed to archive hundreds of thousands of values. Embedded sensors and intelligent devices provide grid operators with rivers of data. This advanced capability effortlessly collects, archives and enables the observer to visualize and analyze the primary process data.

05 RTU500 series

brings the information from the physical power grid to the SCADA system. Their design includes strong and resilient cyber security features to secure communications in all types of networks – providing peace of mind and confidence in the network.

03 System Data Manager SDM600

SDM600 is the gatekeeper to the automation network; it is a comprehensive software solution for automatic management of service and cyber security-relevant data across your substations. The IEC61850-compliant system keeps a watchful eye on protection relays so the user can ensure they're all running the latest software, and to the greatest effect.

06 RTU500 web HMI

Integrated HMI of RTU500 enables a state-of-the-art monitoring and control solution for various processes like transmission and distribution networks, building automation, transportation and industry. It's designed for fixed installation or portable workplaces.



07

07 Wired Communication Networks
 ABB's wired and wireless communications technology serves customers in numerous areas including power generation, power transmission and distribution as well as customers in mining, oil and gas, transportation and public infrastructure.



08

08 Protection and Control relays
 Designed for remote control and monitoring protection, fault indication, power quality analysis and automation. Protection and control relays represent the control center of a switchgear panel.



09

09 Wireless Communication Networks
 ABB offers robust and cost effective solutions for building communications links to physically disparate locations, industrial Internet of Things (IIoT) end points and mobile devices across geographies that spans a few miles or thousands of miles. With a wide range of robust wireless communication products and services, ABB can meet the challenges of any environment.

Tools

ABB's comprehensive suites of tools for engineering, integration and testing supports you throughout the complete lifecycle of protection and control IEDs and IEC 61850-based substation automation systems. With many advanced features, the tools allow you to manage your installation efficiently from engineering and commissioning to operation and maintenance.

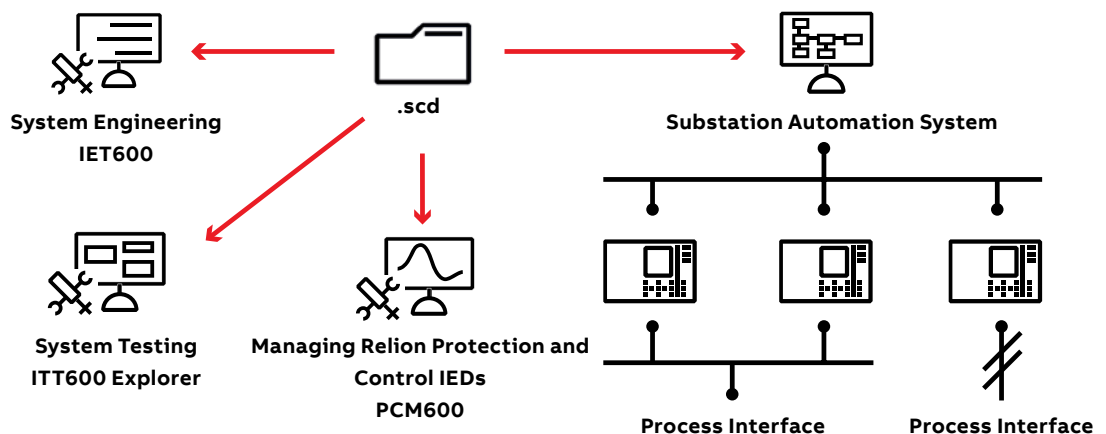

Integrated Engineering Tool IET 600
 Designed for configuring IEC61850-based fully digital substation automation systems and applications.

Integrated Testing Tool ITT600
 SA Explorer is designed for easy diagnosis and troubleshooting of IEC 61850-based substation automation systems and applications.

PCM600 interacts with IEDs over the fast and reliable TCP/IP protocol via a corporate LAN or WAN, or directly through the communication port at the IED. It is able to read and write all configuration and setting data of an IED with a single command.

Complete solutions

from specification to system delivery and service.

State-of-the-art specifications are based on the computer specification (the system specification description or SSD file), which contains the single-line diagram and the allocated functionality. Our scalable solutions are based on IED capability, which are defined by ICD files. ABB engineers the optimal system solutions at the bay and station level. Our systems are thoroughly tested in our System Verification Center. These solutions are adapted according to the user requirements, including the integration of third party equipment.

The delivered system is documented in a substation configuration description (SCD) file, which contains the substation topology (single-line diagram), the communication between functions at the bay and station level, as well as the logical nodes representative of the required functions. This procedure also ensures full data entry and an exact copy in the event of identical bay types. Based on this SCD file, the different tests (including FAT & SAT) can be easily performed and the user facilities for easy adaptation or extensions later on. The result is an optional system delivery, with high-quality documentation and excellent performance.

Engineering

The client requirements are integrated and processed into the basic/detail design by experienced specialists, applying and utilizing the experience of the ABB automated engineering tools. This automation will minimize the risk of errors and will improve the quality of the supplied system and reduce the commissioning and testing time.

Project management

ABB's world-class project management, system integration know-how and intimate knowledge of the complete power process are just as important as our sophisticated solutions – they are the key to ensuring the successful, timely and competent realization of your project. ABB has an unrivaled wealth of global experience, and our ongoing interaction with customer engineers means we continue to deliver added value for our customers.

Manufacturing & testing

ABB manufactures according to the highest standards, with streamlined and flexible processes to ensure that quality is consistently maintained. Our testing area is equipped with state-of-the-art facilities developed in-house, and we ensure smooth installation and commissioning.

Commissioning

ABB employs specialized testing and commissioning engineers, and we are available to supervise commissioning and testing on site upon request. ABB is also able to recruit commissioning engineers from our local units around the globe.

Training center

We train an average of 800 participants per year in automation, protection, SCADA (supervisory control and data acquisition) applications and power system management, on location at ABB University (Baden, Switzerland) or directly at the customers' premises. We are also in charge of empowering our engineering centers in IEC 61850 SA system integration.

Developing business with EPCs

ABB's global engineering center is the point of contact for engineering, procurement and construction (EPC) contractors, guaranteeing fast and easy cooperation. Loose-engineered systems turn into cost-effective, turnkey solutions with standardized processes, implementing the latest technology and full compliance to specifications, while keeping risk low for the EPCs.

Customer support and service

We are concerned for, and take care of our customers requirements even after realization including the support of older installations irrespective of which OEM, main or EPC contractor has integrated our products and systems into the plant.



System Verification and Validation Center (SVC)
IEC 61850 Grid Automation

Cyber security protection over system lifecycles.

End-to-end cyber security solution.

Cyber security measures help to monitor, manage and protect systems and products, ensuring they comply with industrial standards and follow the defense in depth approach. All grid automation systems from ABB are designed and configured according to best practices and provide a broad range of cyber security measures, which are grouped into three main categories:

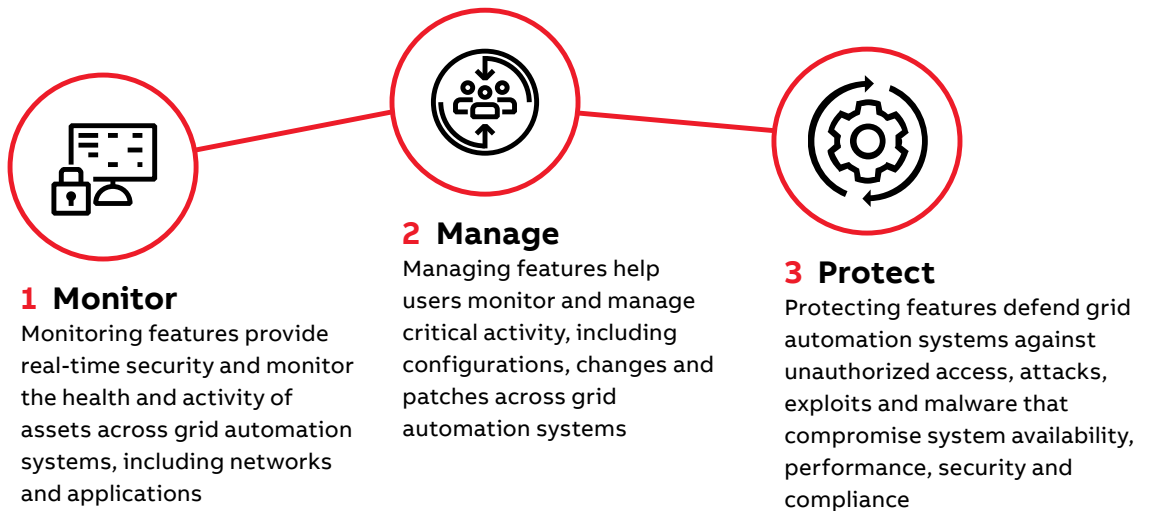

- L3-Communication level:**
 - Secure communication
 - (Encryption, real-time)
- L2-Station level:**
 - Zoning & perimeter protection
 - Malware protection
 - Patch management
 - Backup & recovery
 - Account management
 - Security logging & monitoring
 - System hardening
- L1-Bay level:**
 - Zoning & perimeter protection
 - Secure communication
 - Account management
 - Security logging & monitoring
 - Product hardening

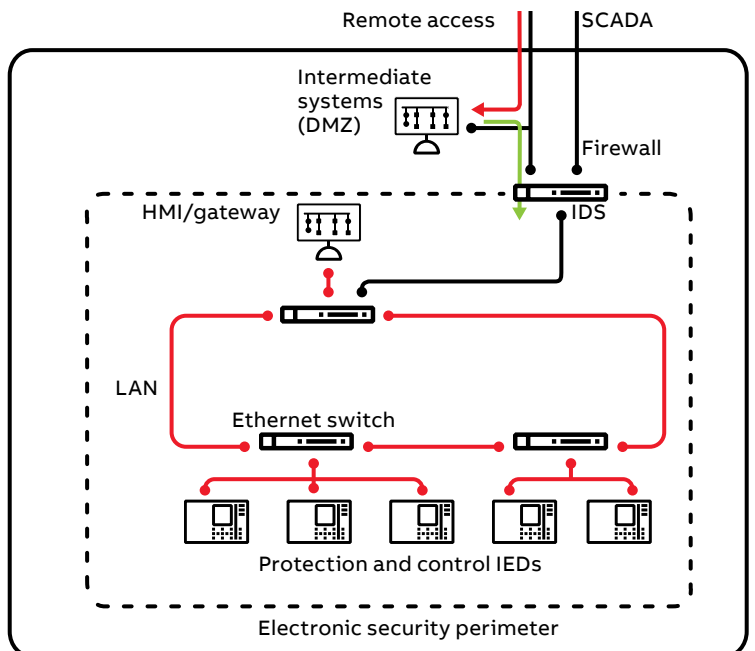

Physical security perimeter

ABB Power Grids service.

Your strategic partner for a changing world.

Spare parts

We offer spare part services for hundreds of parts, delivered quickly to any destination.

Training

Your strategic partner for a changing world.

Rapid response

We guarantee fast and flexible response to maximize your equipment uptime.

Preventative maintenance

We employ powerful tools and knowledge to optimize and extend your equipment life.

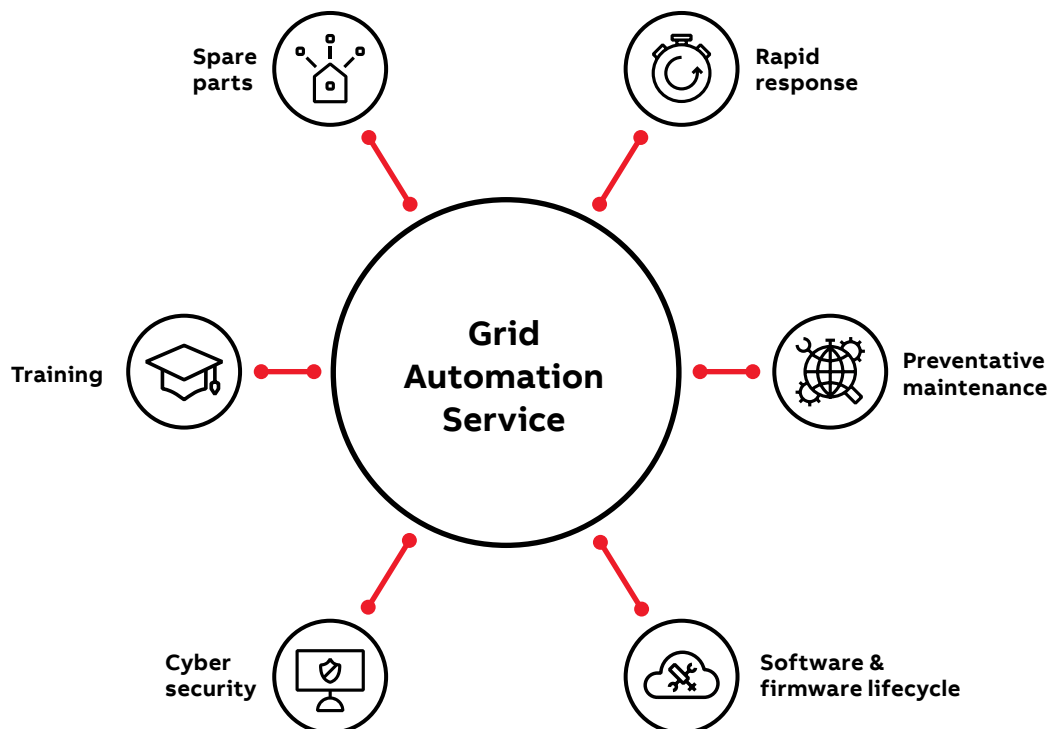

Cyber security

We enable smarter system protection to make your utilities more efficient, more productive, and more economic

Software & firmware lifecycle

We optimize connectivity, reliability and efficiency of your assets to increase speed and yield.

ABB Power Grids service.

Your strategic partner for a changing world.

We may not make the world go round, but ABB's global Customer Care team does its part to keep it running. Through our four key pillars of focus, we provide ongoing technical and functional support to help you meet your objectives.

Rapid response

When something goes wrong, you need it fixed fast! Whether it's spare parts, replacement equipment or repairs, our care agreements are tailored to your needs. Our remote services and 24x7 call center also provides quick troubleshooting and root cause analysis services so you can identify the most effective course of action and address problems before they grow.

Preventative maintenance

We employ powerful tools and knowledge to optimize and extend your equipment life. Hitting key performance targets can be tough to do when you're trying to keep costs under control. Our team can devise solutions that help you hit your targets as well as provide software applications that deliver actionable insights for future performance improvements.

Software & firmware lifecycle

We optimize connectivity, reliability and efficiency of your assets to increase speed and yield. We can help you extend the life of your assets with extensions, upgrades, and retrofits. When it's time to retire an asset, we offer end-of-life services that help you do so cost-effectively and responsibly.

Cyber security

We enable smarter system protection to make your utilities more efficient, more productive, and more economic. When you need to optimize or modernize your processes, our service team can help you assess the challenge and design cost-effective, fit-for-future solutions. In addition, we offer a wide range of commercial and proprietary enterprise-level applications to help you improve operational efficiency.

Spare parts

We enable smarter system protection to make your utilities more efficient, more productive, and more economic. From cradle to grave, Grid Automation Service is there to help you take care of your assets by providing installation and commissioning services, maintenance, replacements, spare parts and consumables, and training. We can also help you extend the life of your assets with extensions, upgrades, and retrofits. When it's time to retire an asset, we offer end-of-life services that help you do so cost-effectively and responsibly.

Training

Your strategic partner for a changing world. We offer training at ABB's facilities at ABB University training center and customized training programs and tailored courses at your site, as well as online training.

We are with you around the world

ABB Power Grids Service has more than 150 Customer Care Centers strategically located around the globe. These one-stop shops are staffed by 6,000 professionals with extensive industry and service experience on a wide array of power equipment and systems. Our team of power experts and analysts can help you address today's toughest power challenges and prepare you to meet the challenges of the future.





ABB Digital Substation

A significant breakthrough in substation technology.

Based on the seamless integration of state-of-the-art IEC 61850-based control and protection IEDs, with all relevant primary components and sensors of a modern substation. The primary components include high and medium-voltage switchgear, as well as substation transformers.

— 01 Protection and control building including automation, protection and control, and IEC 61850 station bus.

— 02 MPLS-TP network remote connectivity via ABB FOX615 utility-hardened multiplexer.

— 03 Transformer with electronic control monitoring and diagnostics.

— 04 Integrated non-conventional instrument transformers.

— 05 Merging units & process I/O bridging the gap between the analog and digital worlds. IEC 61850 compliant.

— 06 IEC 61850 Process bus connecting the switchyard to the protection and control system.

— 07 ABB Ability™ Network Manager control center solutions to ensure secure and efficient energy system operation.

The defining feature of a Digital Substation is the implementation of a process bus. The IEC 61850 process bus enables the substitution of point-to-point copper connections between IEDs, other devices (e.g., instrument transformers, gas monitoring, MotorDrive™, etc.) and switchgear by means of a safe, standardized optical communication bus. Thanks to the process bus, real-time measurement signals and status information can be broadcast throughout a substation without complex wiring schemes.

In the late nineties, ABB commissioned the world's first Digital Substation in Australia for Powerlink, a transmission service provider in Queensland. Even though the concept has evolved since then, the basic principles remain the same: substituting heavy and bulky current and voltage sensors with small, integrated sensors and substitute signaling copper wires with fiber optic communication buses.

From 2008 onwards, ABB introduced the IEC61850-9-2 process bus between non-conventional instrument transformers and protection and control equipment. Digital Substations enable electric power utilities to increase productivity, reduce footprint, increase functionality, improve the reliability of assets and, crucially, improve safety for service personnel. Digital Substations exploit the benefits of digital protection, control and communication technologies, mirroring the trend towards digitalization seen in many other industries.

This trend towards digitalization also applies to other areas of the substation. Within medium-voltage switchgear panels, the horizontal exchange of IEC 61850-8-1 GOOSE and sampled analog values reduces wiring and accelerates the testing and commissioning. Digitalized technology can now continuously monitor mission-critical functions of high and medium voltage switchgear as well as substation transformers, while performing real-time simulation and diagnostics, ensuring that the proactive management of the assets lifecycle is now possible.

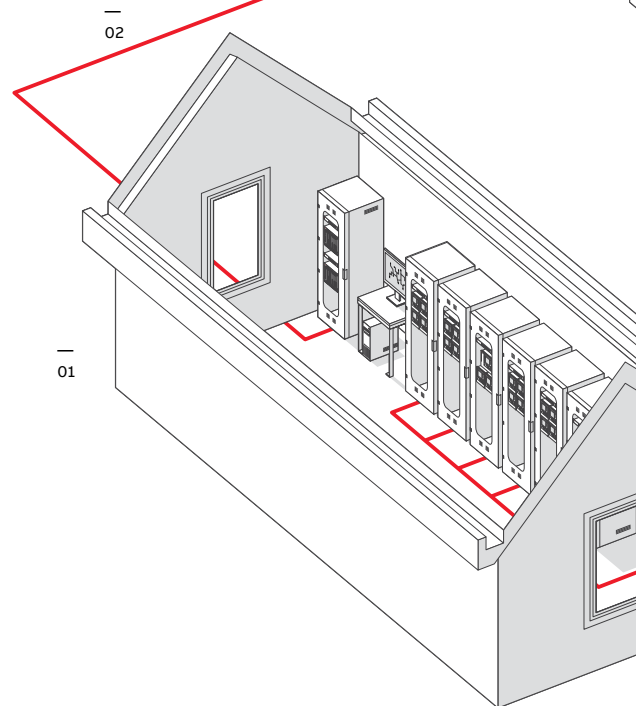

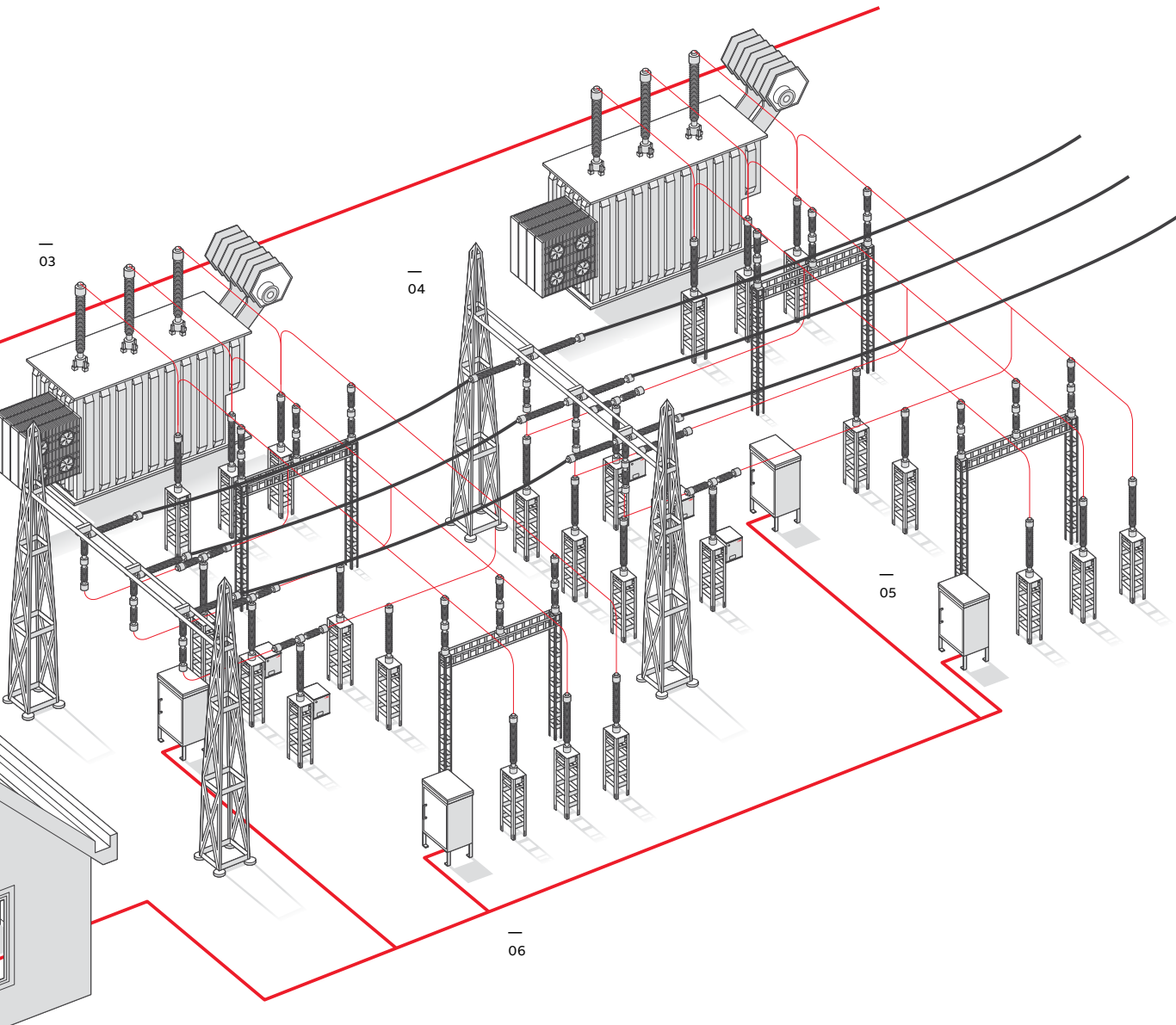

The availability of increasing amounts of data in the substation calls for better solutions to turn this data into actionable information, and to ensure that the data is properly and securely managed. The latest substation data management and asset health management solutions offer the means for a power utility to exploit the latest advances in this area.

The ABB Digital Substation has also paved the way for well-known innovative switchgear solutions such as PASS (plug and switch system) and, most recently, the disconnecting circuit breakers with integrated fiber optic current sensors (DCB with FOCS).





ABB Switzerland Ltd.
Power Grids
Grid Automation
Bruggerstrasse 72
CH-5400 Baden, Switzerland
Phone +41 84 484 58 45

new.abb.com/substation-automation

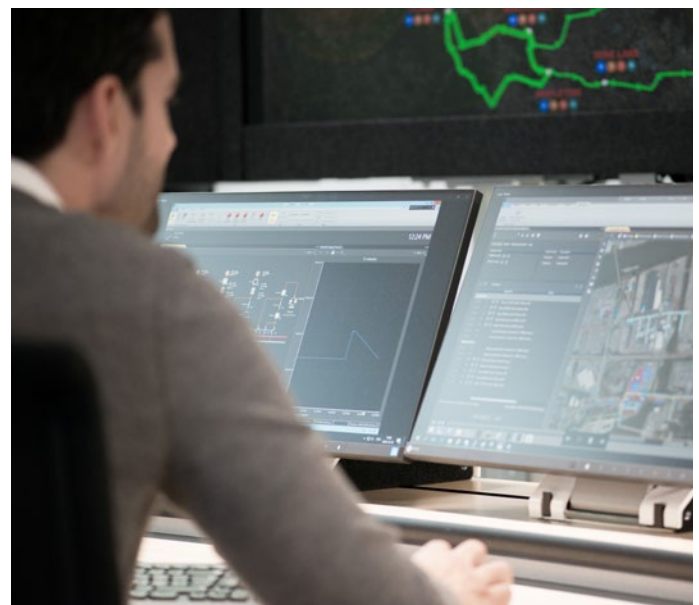