

Superbolt

Pretensioning Systems - Instructions

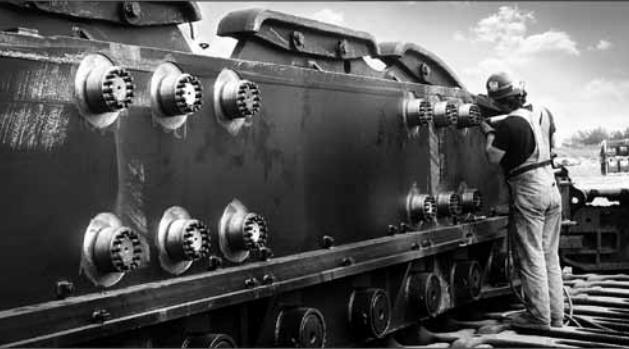

By turning the jackbolts, a strong thrust force is generated. This thrust force is directed against a hardened washer. Jackbolts have a small friction diameter creating a high thrust force for relatively little torque.



The loads are transferred through the nut body which is positioned on the main thread by hand.

A hardened washer is used to transfer the force whilst protecting the flange face and nut body.

The thrust force of many jackbolts and the opposite reaction force of the main bolt head create a strong clamping force on the flange.

The thrust force from the jackbolt creates an equally strong reaction force in the main bolt head.

Instructions

With Superbolt® tensioners you have chosen a technologically superior product. It is purely mechanical and, therefore, very safe.

The following simple steps will help you with your application. Thereby you increase safety, speed and service life.

Content	page/s
1. Tightening procedure	4/5
2. Loosening procedure	6/7
3. Lubrication and tools	8/9
4. Maintenance	10
5. General notes	11
6. Consultance	12

These instructions are valid for Superbolt® standard pretensioning systems according to Nord-Lock AG data sheets:

Tensioners:

- MT / MTT / MTL / MTA
- MR / MRA
- CY
- SJ / SJL / SJX
- GR2
- SM
- H650 / H650T
- H850 / H850T
- SH / SHT

Torquebolts:

- SB8
- SB12
- SBU
- SSJ

1. Tightening procedure

1.1 Check:

- Which jackbolt torque?
Recommended torque M see
- your internal directives
 - Nord-Lock AG certificate
 - Nord-Lock AG data sheet

Attention: The jackbolt torque engraved on the tensioner body is the maximum value which may be unsuitable for your application. The indicated torques are theoretical values. The achieved elongations of the studs are relevant.



1.2 Which tools?

- suitable torque wrench
- matching socket, heavy duty line
- lubricant

1.3 Preparation:

- Clean main thread and contact areas and lubricate well with suitable anti-seize lubricant (A), put on washer (B).
- Make certain that the jackbolts on the Superbolt® tensioner do not protrude beyond the load surface and are well lubricated. If necessary, relubricate with the recommended Superbolt® lubricant (see certificate).
- Firmly tighten tensioner by hand, if necessary by using a screwdriver stuck between the jackbolts or the like (D).
- Afterwards turn back approx. 1/4 turn. Depending on size the gap will be approx. 1 to 3 mm wide (E).
- The actual tightening occurs in a few steps:

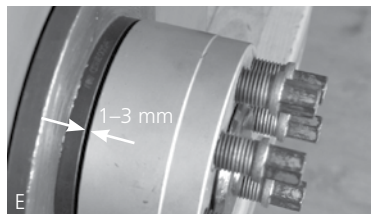
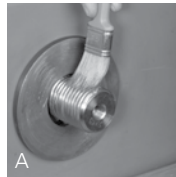

1.4 Tightening:

Step 1:

Tighten 4 jackbolts by hand or using a small wrench to center the main thread and to eliminate backlash. Tighten bolts crosswise.

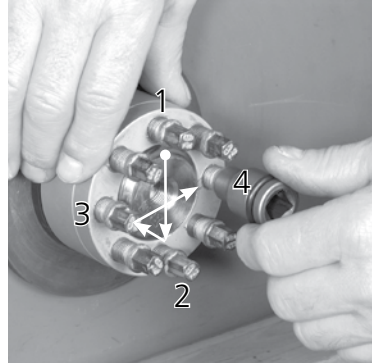

Step 2:

Now tighten these 4 jackbolts crosswise with 50% of the recommended jackbolt torque.



Step 3:

Tighten the same 4 jackbolts crosswise with 100%.

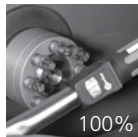

Step 4:

Now change to circular tightening and tighten all jackbolts with 100% of the recommended jackbolt torque.

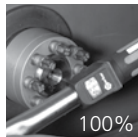

Step 5:

Repeat step 4 until all jackbolts are equally tightened (less than 20° remaining movement). Normally 2 to 3 passes are sufficient, with long bolts accordingly more.



Power tools can save time, see item 3.3.

2. Loosening procedure

Attention: Loosening requires an exact procedure. The jackbolts must be unloaded stepwise! Under no circumstances unload single screws completely. The remaining screws would have to carry the entire load and, therefore, would be difficult to loosen. In extreme cases the jackbolts could mushroom and make loosening impossible!

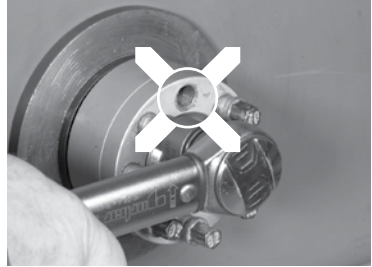

2.1 Usage at normal temperatures (< 100 °C)

Preparation: Before loosening apply penetrating oil, especially with any rust formation.



Step 1:
Starting with N° 1 loosen every jackbolt in a circular pattern approx. 1/4 turn (breaking loose is sufficient). After the first round jackbolt N° 1 will be tightened again, however, on a lower level of loading.

Note: Should several tensioners be loosened, i.e. on a flange, perform step 1 on all tensioners before moving to step 2.



Step 2:
In a 2nd round repeat step 1, again on all tensioners.

Step 3:
Repeat step 1 in a 3rd round.

Step 4:
Relieve jackbolts completely. Now the tensioner can be removed by hand.

Note: Long screws expand more and, therefore, may require one or two passes more.

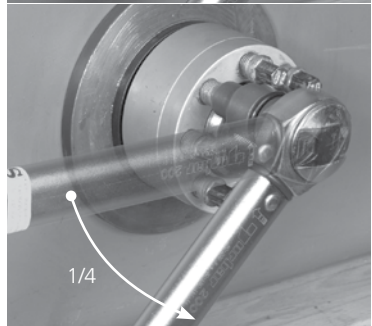

Attention: Before re-using follow maintenance instructions!

2.2 Usage at high temperatures (> 100 °C)

Preparation: At higher temperatures the petroleum base of the lubricant evaporates, thereby increasing the effort for loosening.

Step 1:

If possible, already apply penetrating oil during cooling of the installation (at approx. 150 °C). At even higher temperatures use synthetic oil.



Step 2:

Starting with N° 1 break loose each jackbolt of one tensioner in a circular pattern.

Note: Do not loosen beyond break loose point, and break loose all jackbolts of all tensioners of a joint first.

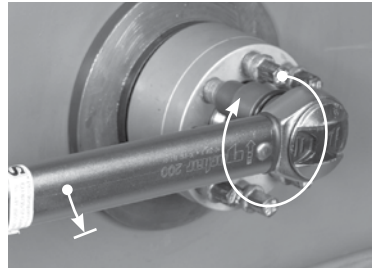

Step 3:

The actual loosening occurs according to the procedure described under item 2.1 (normal case), beginning with step 1.

Note: For high temperature applications bolts with bores are often used. Through the use of heating rods the loosening of Superbolt® tensioners can be substantially facilitated. Five minutes of heating are already sufficient to accelerate loosening.

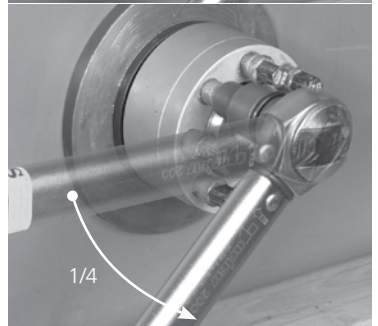

3. Lubrication and tools

3.1 Lubricant

Jackbolts: The jackbolts are delivered pre-lubricated and are ready for use. Refer to the certificate for the lubricant. For jackbolts use only Superbolt® lubricants or substitutes permitted by Nord-Lock AG.

Hardened washers: For the upper side (contact with jackbolts) use the correct Superbolt® lubricant. For the bottom side you may use any suitable anti-seize lubricant.

Main thread: Any suitable anti-seize lubricant including Superbolt® lubricants may be used. Apply with brush or spray.



3.2 Sockets

For tightening the jackbolts only high quality tools in good working order should be used. Heavy duty sockets for use with impact tools are best suited. Worn sockets are dangerous and should be disposed of.

3.3 Power tools

Air impact tools have proven to be most suitable. However, with Superbolt® jackbolts they reach only 30...50% of their rated output. Therefore, the largest possible air lines and couplings should be used. Impact tools are suitable to a torque of max. 200 – 250 Nm. Pneumatic wrenches are recommended for large torques, which offer the same control as the impact tools.



3.3 Power tools (continuation)

Adjustment of the correct torque: Tighten one jackbolt to the desired torque with the torque wrench. Then, apply the air impact tool and increase the pressure until the jackbolt starts turning again.

Verifying the torque output of an air impact tool is easy: Tighten until tool stalls, then measure the torque with a torque wrench (preferably with electronic gauge).

When tightening air impact tools are especially suited for steps 2 through 5 and should be adjusted to approx. 90 to 100% of the rated torque.

Important: Because of the lower accuracy of power tools, the last tightening round should always be performed manually with a precision torque wrench.

Attention: Only use air impact tools for tightening, never for loosening.

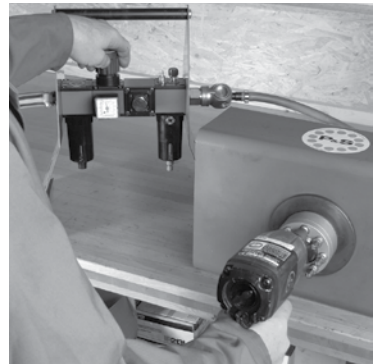
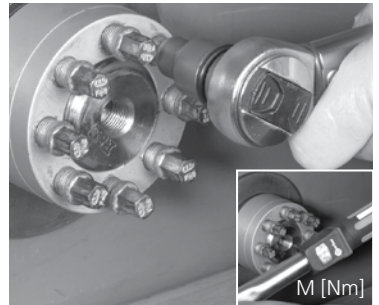
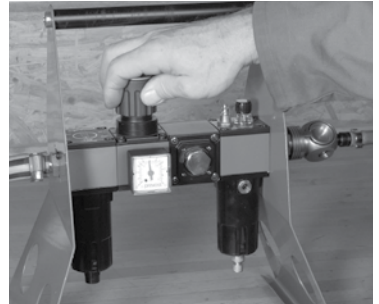

Notes for the use of air impact tools:

Network pressure min. 6,5 bar

- up to 70 Nm 3/8" impact tool or air ratchet
- 70-130 Nm 1/2" impact tool, derated (**Attention:** Do not overshoot!)
- 130-200 Nm 1/2" impact tool
- 200-270 Nm 1/2" impact tool (handy) or 3/4"
- over 270 Nm 3/4" impact tool or 1"
- over 400 Nm 3/4" air impact tool with reaction arm

4. Maintenance

4.1 Regular checks

Superbolt® tensioners do not lose their preload force even after several years in service provided that they are correctly tightened. During revisions (after several years) the preload force should be checked nevertheless. Use a torque wrench adjusted to 100% of the permitted jackbolt torque according to the certificate or your installation procedure.

Should some jackbolts unexpectedly have lost some of the preload force the following procedure is recommended:

- Loosen and remove a single jackbolt. Clean and lubricate with the anti-seize lubricant which is specified in the Nord-Lock AG certificate. Then replace jackbolt and retighten. Repeat for every jackbolt. Thus, the nut remains tensioned.
- Now retension according to tightening procedure – step 5, meaning:
Tighten in circular pattern with full jackbolt torque, until all jackbolts are tightened.

4.2 Preventive maintenance

i.e. for removal for maintenance purposes:

- Relieve according to loosening procedure.
- Clean thread and end of the Superbolt® jackbolts and treat with lubricant according to certificate.
Do not use molybdenum sulfide (MoS_2) unless expressly specified in the certificate.
- Superbolt® hardened washer may be re-used despite indentations simply by turning over. Depressions of a few 1/100 mm are normal.
- Retighten according to tightening procedure.

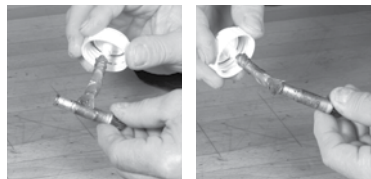

4.3 If you encounter problems

Jackbolts cannot be loosened:

- Try to free at least one jackbolt.
- Remove, lubricate well and tighten with 110% of the recommended jackbolt torque.
- The two neighboring jackbolts should become free.
- Remove also, lubricate and tighten with 110%.
- Again the next two jackbolts should become free.
- And so on.
- Afterwards relieve all jackbolts according to loosening procedure.

Hardened washers are damaged i.e. after a long time in service:

- Exchange against original Superbolt® hardened washers.

Jackbolts are damaged or missing:

- Exchange against original Superbolt® jackbolts.
Do not use commercially available screws because they are not suitable for such high loads.

Other problems:

- Please contact your supplier or national Nord-Lock office directly.

5. General notes

5.1 Tightening of tensioners with only 4 or 6 jackbolts

Step 1: Tighten all jackbolts by hand crosswise.

Step 2: Tighten 2 opposite jackbolts with 50% of recommended torque.

Step 3: Tighten 2 other opposite jackbolts with 100%.

Step 4: Tighten jackbolts in circular pattern with 100% until they are tightend.

5.2 Tightening of long tie rods

To accelerate tightening of long tie rods it pays off to perform step 4 with increased jackbolt torque (approx. 110–125%).

Attention: In final rounds always check jackbolt torque by hand with 100% to prevent overloading.

5.3 Gaskets with large elastic displacements

It does not matter if some jackbolts (or tensioners on the circumference) become loose during tensioning. This is normal, because in the beginning only those bolts carry loads that are being tightened. Do not spin down loose tensioners, otherwise there will be problems later during loosing. Preferably adjust jackbolts with power tools.

5.4 Tensioning large flanges or joints

For tensioning large flanges/joints preferably work with 2 men 180° apart or 4 men 90° apart.

5.5 Usage of spacers

Tensioners should be positioned on the outer end of a bolt. This protects the main thread. It can be tensioned easier (no extensions necessary) and the expansion is improved. Place suitable spacer or several heavy washers under the hardened washer. Thereby you can bridge over areas that have been damaged by other tightening techniques.

5.6 Retensioning for high temperature applications

If tensioned properly it should not become necessary to retension SUPERBOLT® tensioners. If regular retensioning should nonetheless become necessary, please inform us so that we can re-examine the joint.

5.7 Recutting of the bolt threads can become necessary on bolts that have deformed during years of service, especially at higher temperatures. Likewise on bolts of earlier manufacture that were manufactured with other tolerances.

5.8 Installation tools

Apart from a variety of standard tools for tensioning of Superbolt® tensioners simple special tools are available, which facilitate the installation of large nuts or bolts.

5.9 Protective caps from vinyl, steel or stainless steel are available to protect the tensioners for different applications. Filled with grease they offer good protection against rust at normal temperatures.



6. Consultance

For further information on possible uses, applications and maintenance of Superbolt® pretensioning systems please contact your supplier or national Nord-Lock office directly.

These instructions are also available as information film.

Exclusion of liability

The Nord-Lock Group excludes all liability for unsuitable product selection, improper use as well as damage resulting from disregarding our instructions and directives.

Changes due to technical progress are reserved.

Nord-Lock AG

Rietwiesstrasse 2, CH-8735 St. Gallenkappel, Switzerland
Tel: +41 (0)55 284 64 64, Fax: +41 (0)55 284 64 69
Email: info@nord-lock.ch

Nord-Lock Group

Tel: +46 (0)31 7192 300, Fax: +46 (0)40 240 851
Email: info@nord-lock.com

www.superbolt.com • www.nord-lock.com

NORD-LOCK®
Bolt securing systems