



Superstor Ultra Indirect Fired Water Heaters

Installation

Start-Up

Maintenance

Parts

Warranty

*For Residential and
Commercial Use*

SSU Models

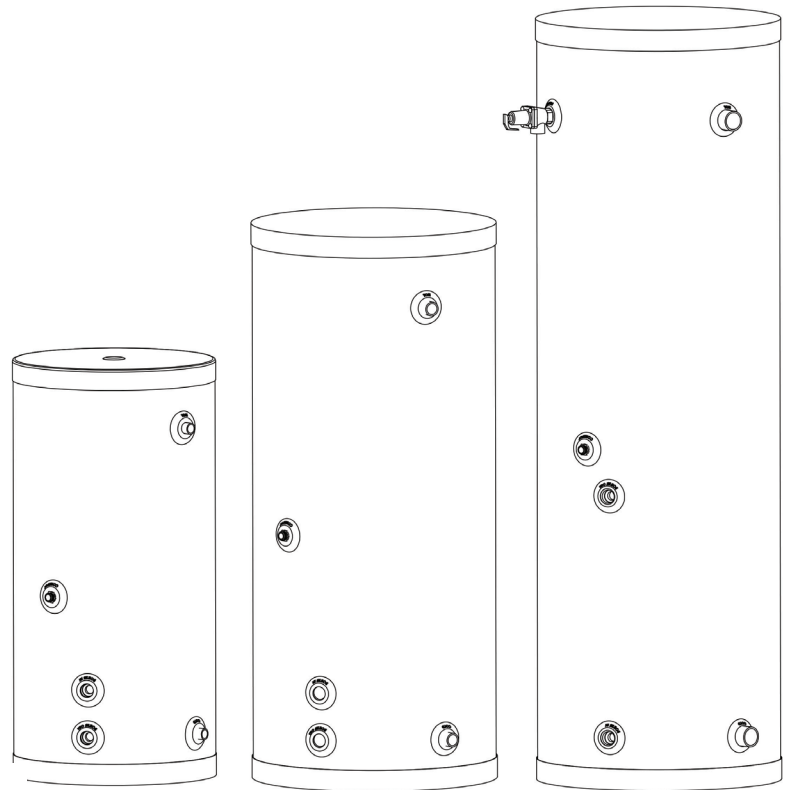

The surfaces of these products contacted by potable (consumable) water contain less than 0.25% lead by weight as required by the Safe Drinking Water Act, Section 1417.



WARNING

This manual must only be used by a qualified installer / service technician. Read all instructions in this manual before installing. Perform steps in the given order. Failure to do so could result in substantial property damage, severe personal injury, or death.

NOTICE

HTP reserves the right to make product changes or updates without notice and will not be held liable for typographical errors in literature.

NOTE TO CONSUMER: PLEASE KEEP ALL INSTRUCTIONS FOR FUTURE REFERENCE.

SPECIAL ATTENTION BOXES	
The following defined terms are used throughout this manual to bring attention to the presence of hazards of various risk levels or to important product information.	
	DANGER
DANGER indicates an imminently hazardous situation which, if not avoided, will result in serious personal injury or death.	
	WARNING
WARNING indicates a potentially hazardous situation which, if not avoided, could result in personal injury or death.	
	CAUTION
CAUTION indicates a potentially hazardous situation which, if not avoided, may result in moderate or minor personal injury.	
CAUTION used without the safety alert symbol indicates a potentially hazardous situation which, if not avoided, may result in property damage.	
NOTICE	
NOTICE is used to address practices not related to personal injury.	

Foreword

This manual is intended to be used in conjunction with other literature provided with the SuperStor Indirect Fired Water Heater. This includes all related control information. It is important that this manual, all other documents included in this system, and additional publications including the *Code for the Installation of Heat Producing Appliances* (latest version), be reviewed in their entirety before beginning any work.

Installation should be made in accordance with the regulations of the Authority Having Jurisdiction, local code authorities, and utility companies which pertain to this type of water heating equipment.

Authority Having Jurisdiction (AHJ) – The Authority Having Jurisdiction may be a federal, state, local government, or individual such as a fire chief, fire marshal, chief of a fire prevention bureau, labor department or health department, building official or electrical inspector, or others having statutory authority. In some circumstances, the property owner or his/her agent assumes the role, and at government installations, the commanding officer or departmental official may be the AHJ.

NOTE: HTP, Inc. reserves the right to modify product technical specifications and components without prior notice.

For the Installer

This water heater must be installed by qualified and licensed personnel. The installer should be guided by the instructions furnished with the water heater, and by local codes and utility company requirements.

Installations Must Comply With:

Local, state, provincial, and national codes, laws, regulations, and ordinances.

Table of Contents

Part 1 - General Safety Information	2
A. When Servicing the Water Heating System	3
B. Heater Water	3
C. Freeze Protection	3
D. Water Temperature Adjustment	3
Part 2 - Prepare the Water Heater	3
A. Locating the Water Heater	4
B. Performance and Sizing Guidelines	6
C. Reduced Boiler Input Sizing Guide	7
D. Water Chemistry Requirements	8
Part 3 - Piping	8
A. Plumbing	8
B. Boiler Connections	8
C. Domestic Piping Inlet	9
D. Temperature and Pressure Relief Valve	9
E. Scalding	9
F. Potable Expansion Tank	10
G. Pressure Drop Sizing For Circulator	10
H. Applications	10
Part 4 - Heater Control and Wiring	15
A. Control	15
B. Wiring	15
C. Wiring Diagrams	15
Part 5 - Start-Up and Operation	19
Part 6 - Maintenance and Troubleshooting	20
Limited Warranty	22
Customer Installation Record Form	24

Part 1 - General Safety Information

This water heater is approved for indoor installation only and is not intended for use as a pool heater. Clearance to combustible materials: 0" top, bottom, sides, and back. Heater must have room for service: 24" front, 6" top, and 0" sides are recommended service clearances. (A combustible door or removable panel is acceptable front clearance.) This water heater has been approved for closet installation and installation on combustible flooring. Do not install directly on carpeting. Install the water heater in a location where temperature and pressure relief valve discharge or a leak will not result in damage to the surrounding area. If such a location is not available, install an auxiliary catch pan.

 WARNING	
Installer	Read all instructions in this manual before installing. Perform steps in the given order.
User	This manual is for use only by a qualified heating installer / service technician. Have this water heater serviced / inspected annually by a qualified service technician.
FAILURE TO ADHERE TO THE GUIDELINES ON THIS PAGE CAN RESULT IN SUBSTANTIAL PROPERTY DAMAGE, SEVERE PERSONAL INJURY, OR DEATH.	
NOTE:	Obey all local codes. Obtain all applicable permits before installing the water heater.
NOTE:	Install all system components and piping in such a manner that does not reduce the performance of any fire rated assembly.

⚠ WARNING

NOTE: If the heater is exposed to the following, do not operate until all corrective steps have been made by a qualified serviceman:

1. Fire
2. Damage
3. Water

Failure to follow this information could result in property damage, severe personal injury, or death.

CAUTION

High heat sources (sources generating heat 100°F / 37°C or greater, such as stove pipes, space heaters, etc.) may damage plastic components of the water heater as well as plastic vent pipe materials. Such damages ARE NOT covered by warranty. It is recommended to keep a minimum clearance of 8" from high heat sources. Observe heat source manufacturer instructions, as well as local, state, provincial, and national codes, laws, regulations and ordinances when installing this water heater and related components near high heat sources.

Do not use this water heater for anything other than its intended purpose (as described in this manual). Doing so could result in property damage and WILL VOID product warranty.

NOTICE

UNCRATING THE WATER HEATER - Any claims for damage or shortage in shipment must be filed immediately against the transportation company by the consignee.

A. When Servicing the Water Heating System

To avoid electric shock, disconnect electrical supply before performing maintenance.

To avoid severe burns, allow water heater and associated equipment to cool before servicing.

B. Heater Water

Do not use petroleum-based cleaning or sealing compounds in a water heating system. Gaskets and seals in the system may be damaged. This can result in substantial property damage. Do not use "homemade cures" or "patent medicines". Damage to the water heater, substantial property damage, and/or serious personal injury may result.

NOTICE FOR SINGLE-WALL HEAT EXCHANGER MODELS

Per the Uniform Plumbing Code:

Single-wall heat exchangers are permitted if they satisfy all of the following requirements:

The heat exchanger medium is potable water or contains only substances which are recognized as safe by the US Food and Drug Administration (FDA).

The pressure of the heat exchanger medium is maintained less than the normal minimum operating pressure of the potable water system (steam systems must comply with this statement).

The equipment is permanently labeled to indicate that only additives recognized as safe by the FDA shall be used as the heat transfer medium.

Other heat exchanger designs may be permitted where approved by the AHJ.

C. Freeze Protection

NOTE: Consider piping and installation when determining heater location. Place the water heater as close to the boiler as possible, in a location not prone to freezing.

CAUTION

Failure of the water heater due to freeze related damage IS NOT covered by product warranty.

In water heaters with single wall heat exchangers, the heat transfer fluid must be water or nontoxic food grade glycol, FDA rated "generally recognized as safe" (GRAS) and having a toxicity rating or class of 1, as listed in Clinical Toxicology of Commercial Products, 5th edition. Ensure the system is permanently labeled to indicate any additives used in the heat transfer fluid.

⚠ WARNING

NEVER use any toxic chemical, including automotive, standard glycol antifreeze, or ethylene glycol made for hydronic (non-potable) systems. These chemicals can attack gaskets and seals in water systems, are poisonous if consumed, and can cause personal injury or death.

D. Water Temperature Adjustment

If the water heater is going to have a set temperature above 120°F, you must use an ASSE 1017 rated mixing valve to avoid severe burns or death from scalding temperatures.

⚠ WARNING

Households with small children, disabled, or elderly persons may require a 120°F or lower temperature setting to prevent severe personal injury or death due to scalding.

Approximate Time / Temperature Relationships in Scalds	
120°F	More than 5 minutes
125°F	1 1/2 to 2 minutes
130°F	About 30 seconds
135°F	About 10 seconds
140°F	Less than 5 seconds
145°F	Less than 3 seconds
150°F	About 1 1/2 seconds
155°F	About 1 second

Table 1 - Approximate Time / Temperature Relationships in Scalds

Part 2 - Prepare the Water Heater

Remove all sides of the shipping crate to allow the heater to be moved into its installation location.

CAUTION

COLD WEATHER HANDLING - If the water heater has been stored in a very cold location (BELOW 0°F) before installation, handle with care until the components come to room temperature. Failure to do so could result in damage to the water heater.

A. Locating the Water Heater

CAUTION

High heat sources (generating heat 100°F / 37°C or greater, such as stove pipes, space heaters, etc.) may damage plastic components of the water heater as well as plastic vent pipe materials. Such damages ARE NOT covered by warranty. It is recommended to keep a minimum clearance of 8" from high heat sources. Observe heat source manufacturer instructions, as well as local, state, provincial, and national codes, laws, regulations, and ordinances when installing this water heater and related components near high heat sources.

Locate the water heater where any leakage from the relief valve, related piping, tank, or connections will not result in damage to surrounding areas or lower floors of the building. The water heater should be located near a floor drain or installed in a drain pan. HTP WILL NOT be held liable for leakage damages.

This water heater is certified for indoor use only. DO NOT INSTALL OUTDOORS. Outdoor installations ARE NOT covered by warranty.

Choose a location for the water heater as centralized to the piping system as possible. Also, locate the water heater and domestic water piping where it will not be exposed to freezing temperatures. All piping should be insulated. Additionally, place the water heater so that the drain, controls, and inlets/outlets are easily accessible.

NOTE: To save on heating costs and improve energy efficiency keep the distance between the boiler and water heater to a minimum to reduce heat loss from excess piping and keep friction loss at a minimum. Ensure all piping between the boiler and water heater is properly insulated to minimize heat loss.

The water heater may be located some distance from the boiler provided the circulator meets flow requirements through the coil. The greater the distance from the water heater to the boiler the longer the response will be to a call for hot water.

This water heater must be installed vertical on a level surface.

NOTE: In the State of California, the water heater must be braced, anchored, or strapped to avoid moving during an earthquake. Contact local utilities for code requirements in your area. Visit <http://www.dsa.dgs.ca.gov> or call 1-916-445-8100 and request instructions.

However, applicable local codes shall govern installation. For residential water heaters of a capacity greater than 52 gallons, consult the local building jurisdiction for acceptable bracing procedures.

NOTE: If you do not provide the minimum clearances shown in Figure 1, it might not be possible to service the water heater without removing it from the space.

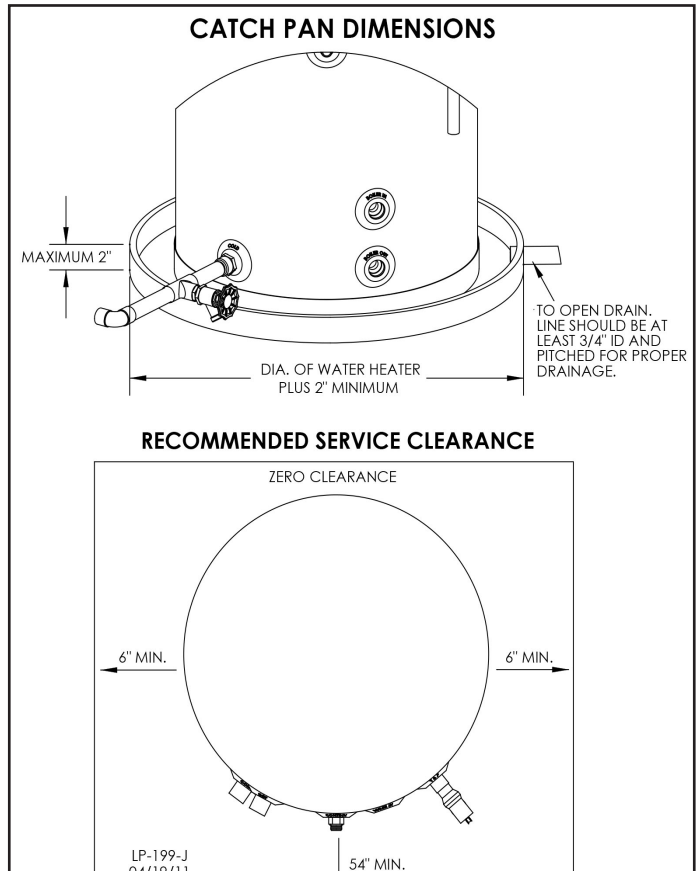

Figure 1 - Recommended Service Clearances

⚠ DANGER

This water heater must not be located near flammable liquids such as gasoline, butane, liquefied propane, adhesives, solvents, paint thinners, etc., as the controls of this water heater could ignite these vapors and cause an explosion resulting in property damage, severe personal injury, or death.

⚠ WARNING

Ensure the location can support the entire filled weight of the water heater. Failure to properly support the water heater could result in property damage, severe personal injury, or death.

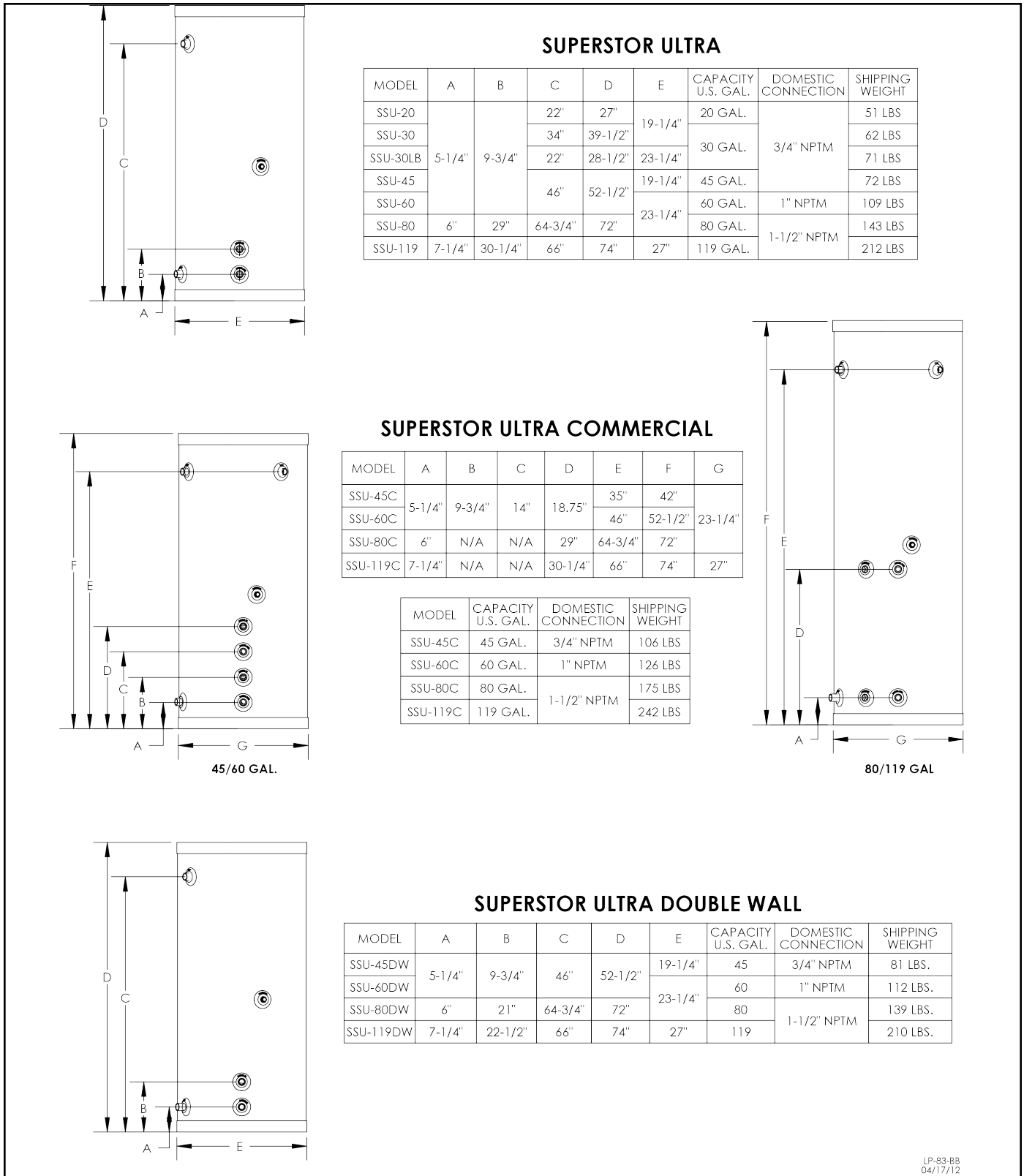

Figure 2 - Dimensions

LP-83-88
04/17/12

SUPERSTOR ULTRA											
MODEL	HEAT EXCHANGER SURFACE/VOLUME	PRESSURE DROP (FT.)	TEST PRESSURE	WORKING PRESSURE	180° BOILER WATER FIRST HOUR RATINGS (GAL) *		200° BOILER WATER FIRST HOUR RATINGS (GAL) *		180° F BOILER BTU/SIZE	200° F BOILER BTU/SIZE	RECOMMENDED FLOW RATE
					140° F	115° F	140° F	115° F			
SSU-20	15 SQ. FT./1.5 GAL.	6.0	300 PSI	150 PSI	121	168	136	185	84,000	87,000	8
SSU-30					154	212	172	234	102,000	117,000	
SSU-30LB					169	234	189	257	114,000	131,000	
SSU-45	20 SQ. FT./2.0 GAL.	7.9			212	292	237	322	141,000	161,000	10
SSU-60					266	370	298	405	174,000	198,000	
SSU-80	34 SQ. FT./3.0 GAL.	9.1			330	440	370	503	212,000	241,000	12
SSU-119		11.3	423	564	474	645	269,000	301,000	14		
SUPERSTOR ULTRA COMMERCIAL											
MODEL	HEAT EXCHANGER SURFACE/VOLUME	PRESSURE DROP (FT.)	TEST PRESSURE	WORKING PRESSURE	180° BOILER WATER FIRST HOUR RATINGS (GAL) *		200° BOILER WATER FIRST HOUR RATINGS (GAL) *		180° F BOILER BTU/SIZE	200° F BOILER BTU/SIZE	RECOMMENDED FLOW RATE
					140° F	115° F	140° F	115° F			
SSU-45C	40 SQ. FT./4.0 GAL.	6.8	300 PSI	150 PSI	314	414	351	477	215,000	246,000	20
SSU-60C		9.2			354	467	396	539	245,000	270,000	22
SSU-80C	10.0	490			647	548	745	331,000	374,000	24	
SSU-119C	68 SQ. FT./6.0 GAL.	12.7			637	841	713	970	425,000	490,000	28
SUPERSTOR ULTRA DOUBLEWALL											
MODEL	HEAT EXCHANGER SURFACE/VOLUME	RECOMMENDED FLOW RATE (GPM)	PRESSURE DROP (FT.)	TEST PRESSURE	180° BOILER WATER FIRST HOUR RATINGS (GAL) *		200° BOILER WATER FIRST HOUR RATINGS (GAL) *		180° F BOILER BTU/SIZE		
					140° F	115° F	140° F	115° F			
SSU-45DW	15 SQ.FT/1.5 GAL	6	8.2	300 PSI	40	63	70	108	107,000		
SSU-60DW		7	12.8		50	76	90	144	176,000		
SSU-80DW		10	13.6		72	113	138	215	208,000		
SSU-119DW		12	15.9		110	171	210	326	231,000		

*DOE TEST METHOD BASED ON 90° F TEMPERATURE RISE, 50° /140° W/BOILER WATER AT 180° F

NOTE: TANK RECOVERY FROM COLD START WILL BE BETWEEN 10-13 MINUTES WHEN SIZED WITH CORRECT FLOW RATE, BOILER SIZE AND PRESSURE DROP RATINGS FROM LIST IN ABOVE CHART.

LP-83-BB
04/17/12

Figure 3 - Specifications
Continuous Flow Performance Calculation

First Hour Rating - (.75 X Tank Capacity) = Continuous Flow

Example: SSU-45C = 314 - (.75 X 45) = 280.25

B. Performance and Sizing Guidelines

NOTE: The table below describes the minimum BTU/H required to achieve the listed first hour rating.

MODEL	GROSS BOILER OUTPUT	140°F 90°F ΔT	127°F 77°F ΔT	115°F 65°F ΔT
SSU-20	84,000	121	140	168
SSU-30	102,000	154	180	212
SSU-30LB	113,000	169	198	234
SSU-45	141,000	212	248	292
SSU-45C	215,000	314	367	414
SSU-60	174,000	266	311	370
SSU-60C	245,000	354	414	467
SSU-80	212,000	330	386	440
SSU-80C	331,000	490	573	647
SSU-119	269,999	423	495	564
SSU-119C	425,000	637	745	841

Table 2 - Water Heater Performance and Sizing Guidelines

C. Reduced Boiler Input Sizing Guide

NOTE: IT IS NOT RECOMMENDED TO REDUCE BOILER INPUT WHEN USING DOUBLE WALL TANKS.

MODEL		GROSS OUTPUT (x 1,000 BTU/HR)													
		40	60	84	100	120	140	160	180	200	220	240	260	280	300
SSU-20	A	73	112	168				-							
	B	53	81	121				-							
SSU-30	A	83	125	160	212				-						
	B	60	90	115	154				-						
SSU-30LB	A	84	128	166	234				-						
	B	60	92	120	169				-						
SSU-45	A	94	138	180	210	266	292		-						
	B	68	99	130	152	193	212		-						
SSU-60	A	-			221	244	251	309	370			-			
	B	-			160	176	181	206	266			-			
SSU-80	A	-			297	305	314	367	424	489	503			-	
	B	-			216	223	230	269	311	359	370			-	
SSU-119	A	-					333	384	444	457	470	543	627	645	
	B	-					216	251	290	335	345	399	460	474	

Table 3 - Describes Cold Start First Hour Ratings (A and B) and Boiler Size

PRODUCT LINE CONSISTS OF VARIOUS MODELS AVAILABLE IN DIFFERENT SIZES

CALL THE FACTORY FOR PRODUCT AND WARRANTY INFORMATION

“DW” (Double Wall Commercial Heat Exchanger) Models are available in 45, 60, 80, and 119 US Gallon Sizes.

“C” (Commercial) Models with Two Heat Exchangers for dual systems and commercial applications. Use one coil for a wood boiler, the other for a solar system, etc. Models available in 45, 60, 80, and 119 US Gallon Sizes.

DETERMINE THE AMOUNT OF DOMESTIC HOT WATER NEEDED. THEN USE THE TABLE BELOW TO OPTIMIZE WATER HEATER AND BOILER SIZING.

NOTE: FIRST DRAW AT 140°F AT 90°F Δ T. (FOR PERFORMANCE AT 115°F, MULTIPLY BY 1.56 FOR MINUTES OF WATER DRAW.)

LINE A GALLONS: LOW MASS BOILERS THAT TAKE LESS THAN 90 SECONDS TO HEAT TO TEMPERATURE.

LINE B GALLONS: HIGH MASS BOILERS THAT TAKE GREATER THAN 90 SECONDS TO HEAT TO TEMPERATURE.

MODEL		2 GPM	2.5 GPM	3 GPM	3.5 GPM	4 GPM	4.5 GPM	5 GPM
SSU-20	A	9.5	8	7	5.5	4.5	4	3.5
	B	8.5	7.5	6.5	5	4	3.5	3
SSU-30	A	16	13	10	7.5	6	5.5	5
	B	14	12	9	7	5.5	5	4.5
SSU-30LB	A	18	14	12	9	6.5	6	5.5
	B	17	12	10	8	6	5.5	5
SSU-45	A	23	18	14	11	8.5	7.5	7
	B	18	15	13	10	7.5	7.5	6.5
SSU-45C	A	∞	∞	∞	29	20	17	14
	B	45	24	26	18	16	13	10
SSU-60	A	∞	∞	∞	∞	36	30	22
	B					29	19	12
SSU-60C	A	∞	∞	∞	∞	∞	46	29
	B						30	21
SSU-80	A	B	∞	∞	∞	∞	∞	∞
SSU-80C	A	B	∞	∞	∞	∞	∞	∞
SSU-119	A	B	∞	∞	∞	∞	∞	∞
SSU-119C	A	B	∞	∞	∞	∞	∞	∞

Table 4 - NOTE: THIS INFORMATION IS BASED ON BOILER SIZE CONFORMING TO THE MINIMUM BTU/H REQUIRED TO ACHIEVE FIRST HOUR RATINGS, OBTAINABLE FROM FIRST HOUR RATING TABLE. ∞ - Indicates continuous duty.

D. Water Chemistry Requirements

CAUTION

Chemical imbalance of the water supply may affect efficiency and cause severe damage to the water heater and associated equipment. HTP recommends having water quality professionally analyzed to determine whether it is necessary to install a water softener. It is important that the water chemistry on both the domestic hot water and central heating sides are checked before installing the water heater, as water quality will affect the reliability of the system. In addition, operating temperatures above 135°F will further accelerate the build-up of lime scale and may shorten the service life of the water heater. Failure of a water heater due to lime scale build-up, low pH, or other chemical imbalance IS NOT covered by the warranty.

Outlined below are water quality parameters that need to be met in order for the system to operate efficiently for many years.

Water Hardness

Water hardness is mainly due to the presence of calcium and magnesium salts dissolved in water. The concentration of these salts is expressed in mg/L, ppm, or grains per gallon as a measure of relative water hardness. Grains per gallon is the common reference used in the US water heater industry. Hardness expressed as mg/L or ppm may be divided by 17.1 to convert to grains per gallon. Water may be classified as very soft, slightly hard, moderately hard, or hard based on its hardness number. The minerals in the water precipitate out as the water is heated and cause accelerated lime scale accumulation on a heat transfer surface. This lime scale build-up may result in premature failure of the water heater. Operating temperatures above 135°F will further accelerate the build-up of lime scale and may shorten the service life of the water heater.

Water that is classified as hard and very hard must be softened to avoid water heater failure.

CLASSIFICATION	MG/L OR PPM	GRAINS/GAL
Soft	0 - 17.1	0 - 1
Slightly Hard	17.1 - 60	1 - 3.5
Moderately Hard	60 - 120	3.5 - 7
Hard	120 - 180	7 - 10.5
Very Hard	180 and over	10.5 and over

If the hardness of the water exceeds the maximum level of 7 grains per gallon, the water should be softened to a hardness level no lower than 5 grains per gallon. Water softened as low as 0 to 1 grain per gallon may be under-saturated with respect to calcium carbonate, resulting in water that is aggressive and corrosive.

pH of Water

pH is a measure of relative acidity, neutrality, or alkalinity. Dissolved minerals and gases affect water pH. The pH scale ranges from 0 to 14. Water with a pH of 7 is considered neutral. Water with pH lower than 7 is considered acidic. Water with a pH higher than 7 is considered alkaline. A neutral pH (around 7) is desirable for most potable water applications. **Corrosion damage and tank failures resulting from water pH levels of lower than 6 or higher than 8 ARE NOT covered by warranty.** The ideal pH range for water used in a water heater is 7.2 to 7.8.

Total Dissolved Solids

Total Dissolved Solids (TDS) is a measurement of all minerals and solids dissolved in a water sample. The concentration of TDS is usually expressed in parts per million (ppm).

Water with a high TDS concentration will greatly accelerate lime and scale formation in the hot water system. Most high TDS concentration precipitate out of the water when heated. This can generate a scale accumulation that will greatly reduce the service life of the water heater.

The manufacturer of the water heater has no control over water quality, especially TDS levels in your system. TDS in excess of 2000 ppm will accelerate lime and scale formation on the element or the heat exchanger. Water heater failure due to TDS in excess of 2000 ppm IS NOT covered by warranty.

Failure of a water heater due to lime scale build-up IS NOT covered by warranty.

Hardness: Less than 7 grains

Chloride levels: Less than 100 ppm

pH levels: 6 - 8

TDS: Less than 2000 ppm

Sodium: Less than 20 mg/L

Part 3 - Piping

A. Plumbing

It is mandatory that all plumbing be done in accordance with federal, local, and state plumbing codes and practices. Failure to properly install the water heater WILL VOID the warranty. It is also necessary to use both thread tape and pipe dope on all mechanical plumbing connections.

CAUTION

When filling the water heater, open a hot water tap to release air in the tank and piping. Failure to do so could lead to improper water heater operation and damage to components.

B. Boiler Connections

CAUTION

Use two wrenches when tightening water piping at the heater. Use one wrench to prevent the heater return or supply line from turning. Failure to prevent piping connections from turning could cause damage to water heater components.

Use a 1" nominal minimum pipe size when piping with zone valves or circulators.

On the water heater, the boiler supply connects to the outlet of the circulator. The circulator inlet is to be connected to the hot outlet side of the boiler. Be sure that the arrow on the circulator is facing the correct flow direction. (See pressure drop sizing for circulator, this manual.) On the tank, the boiler return connects to the return side of the boiler. The return(s) from heating loop(s) should have a flow check or swing check valve installed before the return pipe from the tank.

In a steam boiler, the tank supply must be connected to the boiler well below the minimum water level. A strainer and drain valve should be installed at the boiler for periodic draining of scale and sludge. Banging and steam bound traps will occur if the boiler water supplied to the heat exchanger has steam or is slightly above the low water cut-off.

NOTE: It is possible to use live steam in the heat exchanger of

the SSU-80 and 119 residential and commercial models ONLY. Using any other SSU model in live steam applications will result in product failure and void the warranty.

C. Domestic Piping Inlet

CAUTION
Never use dielectric fittings or galvanized steel fittings on any domestic water connections. Use only copper or brass fittings. Failure to do so will result in premature water heater failure. Such failure IS NOT covered by warranty.

Use both thread tape and pipe dope to connect an NPT brass tee. On the run, install a brass drain valve. In the branch, install an NPT male X 3/4" (minimum) pipe adapter. A shut-off valve between the city water supply and tank inlet is recommended for ease of service.

It may be recommended to use a back flow preventer - check local codes. If a back flow preventer or a no return valve is used, a thermal expansion tank must be installed on the cold water supply between the tank and valve. If the tank is replacing a tankless coil in the boiler, disconnect coil plumbing and use the cold inlet pipe and hot water outlet pipes for the water heater.

D. Temperature and Pressure Relief Valve

On SSU-80 and SSU-119 residential models, as well as all commercial models, a 3/4" temperature and pressure (T&P) port and relief valve are provided. On all other models, an appropriate T&P valve must be supplied and installed as detailed in the piping diagrams in this installation manual.

Use both thread tape and pipe dope to install an NPT brass T&P relief valve for hot water storage tanks, as required by local codes but not less than valves certified as meeting the requirements for relief valves for hot water heaters (ANSI Z21.22 / CSA 4.4) by a nationally recognized lab that maintains periodic inspection of production listed equipment. Make sure the relief valve is sized to the BTU/Hour capacity of the water heater. The T&P valve must be plumbed down so discharge can exit at least 6" above the structural floor. The relief line cannot be in contact with any live electrical parts. If the relief valve constantly weeps install an expansion tank. See expansion tank manufacturer's instructions for suggestions.

WARNING
To avoid water damage or scalding due to relief valve operation:

- Discharge line must be connected to relief valve outlet and run to a safe place of disposal. Terminate the discharge line in a manner that will prevent possibility of severe burns or property damage should the relief valve discharge.
- Discharge line must be as short as possible and the same size as the valve discharge connection throughout its entire length.
- Discharge line must pitch downward from the valve and terminate at least 6" above the floor drain, making discharge clearly visible.
- The discharge line shall terminate plain, not threaded, with a material serviceable for temperatures of 375°F or greater.

- Do not pipe discharge to any location where freezing could occur.
- No valve may be installed between the relief valve and heater or in the discharge line. Do not plug or place any obstruction in the discharge line.
- Test the operation of the relief valve after filling and pressurizing the system by lifting the lever. Make sure the valve discharges freely. If the valve fails to operate correctly, immediately replace with a new properly rated relief valve.
- Test T&P valve at least once annually to ensure the waterway is clear. If valve does not operate, turn the heater "off" and call a plumber immediately.
- Take care whenever operating relief valve to avoid scalding injury or property damage.

FAILURE TO COMPLY WITH THE ABOVE GUIDELINES COULD RESULT IN FAILURE OF RELIEF VALVE OPERATION, RESULTING IN POSSIBILITY OF SUBSTANTIAL PROPERTY DAMAGE, SEVERE PERSONAL INJURY, OR DEATH.

WARNING
Do not thread a cap or plug into the relief valve or relief valve line under any circumstances! Explosion and property damage, serious injury, or death may result.

RE-INSPECTION OF T&P RELIEF VALVES: T&P valves should be inspected AT LEAST ONCE EVERY THREE YEARS, and replaced if necessary, by a licensed plumbing contractor or qualified service technician to ensure that the product has not been affected by corrosive water conditions and to ensure that the valve and discharged line have not been altered or tampered with illegally. Certain naturally occurring conditions may corrode the valve and its components over time, rendering the valve inoperative. Such conditions can only be detected if the valve and its components are physically removed and inspected. **Do not attempt to conduct an inspection on your own.** Contact your plumbing contractor for a re-inspection to assure continued safety.

FAILURE TO RE-INSPECT THE T&P VALVE AS DIRECTED COULD RESULT IN UNSAFE TEMPERATURE AND/OR PRESSURE BUILD-UP WHICH CAN RESULT IN PROPERTY DAMAGE, SERIOUS PERSONAL INJURY, OR DEATH.

E. Scalding

WARNING
An ASSE 1017 or ASSE 1070 temperature limiting or mixing valve is recommended in installations servicing disabled or elderly persons, or children. Mixing valves do not eliminate the risk of scalding.
To avoid scalding:

- Set the water heater set point temperature as low as possible.
- Feel water before bathing or showering.
- If thermostatic valves are required, use devices specifically designed for such purpose. Install these devices in accordance with instructions provided by the manufacturer.

Failure to install a temperature limiting or mixing valve and follow these instructions could result in property damage, severe personal injury, or death due to scalds.

This water heater can deliver scalding water. Be careful whenever using hot water to avoid scalding injury. Certain appliances such as dishwashers and automatic clothes washers may require increased water temperatures. By setting the thermostat on this heater to obtain the increased water temperature required by these appliances you may create the potential for scald injury.

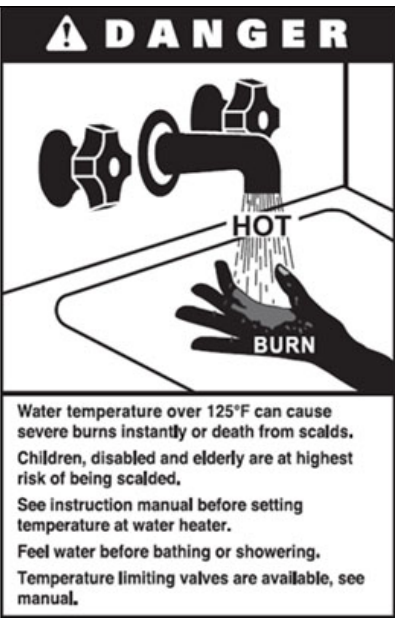

To protect against injury, install a mixing valve in the water system. This valve will reduce point of use discharge temperatures by mixing cold and hot water in branch supply lines. Such valves are available from your local plumbing supplier.

The following table details the relationship of water temperature and time with regard to scald injury and may be used as a guide in determining the safest water temperature for your applications.

Approximate Time / Temperature Relationships in Scalds	
120°F	More than 5 minutes
125°F	1 1/2 to 2 minutes
130°F	About 30 seconds
135°F	About 10 seconds
140°F	Less than 5 seconds
145°F	Less than 3 seconds
150°F	About 1 1/2 seconds
155°F	About 1 second

Table 5 - Approximate Time / Temperature Relationships in Scalds

F. Potable Expansion Tank

A potable hot water expansion tank may be required to offset heated water expansion. If there is a back flow preventer or any other type of no return or check valve in the system a thermal expansion tank IS MANDATORY. The expansion tank must be sized for the entire water volume of the hot water system. A weeping relief valve indicates the need for an expansion tank. See the Typical Expansion Tank example in the Piping section for details.

G. Pressure Drop Sizing For Circulator

The boiler circulator flow rate must meet the requirements found in the water heater specifications, Part 2, this manual, or the published ratings cannot be achieved. The following flow chart below represents the pipe run, water heater, and heat exchanger ONLY and does not include any flow checks, zone valves, or friction loss through the boiler. That resistance must be added to the value found in the following chart.

Pressure Drop for Pipe Length of 1" Copper, Six 90° Elbows, and One Tee					
Pipe Size	20'	30'	40'	50'	60'
6 GPM	8.63	8.93	9.23	9.53	9.8
7 GPM	11.3	11.77	12.24	12.7	13.1
10 GPM	10.25	11.1	11.95	12.8	13.66
12 GPM	11.3	13.2	14.1	15	16
14 GPM	15.3	16.4	17.5	18.6	19.8
Pressure Drop for Pipe Length of 1 1/4" Copper, Six 90° Elbows, and One Tee					
Pipe Size	20'	30'	40'	50'	60'
20 GPM	10.9	11.7	12.6	13.4	14.3
22 GPM	14	15	16	17	18
24 GPM	16.2	17.5	18.8	20.1	21.5
28 GPM	20.4	22	23.6	25.2	26.8

Table 6 - Pressure Drop through 1" and 1 1/4" Copper

H. Applications

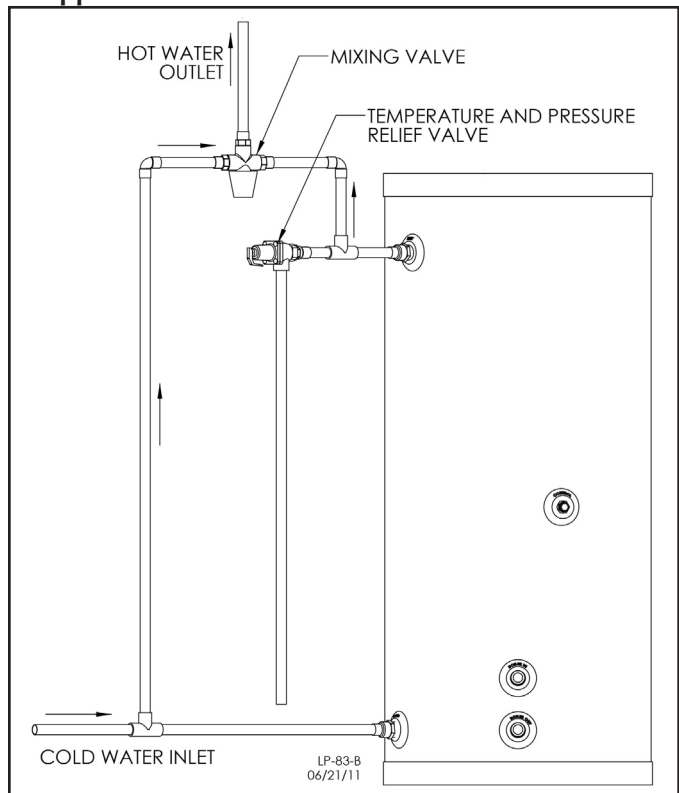

Figure 4 - Mixing Valve Installation

NOTES:

1. Minimum pipe size should match connection size. Upsize pipe accordingly if greater flow is required.
2. A thermal expansion tank suitable for potable water must be sized and installed within this piping system between the backflow preventer and the cold water inlet.
3. All circulators should have an integral flow check.
4. Drains and check valve between unit and storage tank will assist in purging air from system.
5. This drawing is meant to demonstrate system piping only. The installer is responsible for all equipment and detailing required by local codes. In Massachusetts, you must install a vacuum relief valve per 248 CMR.
6. Mixing valve application is optional, but recommended to help prevent scalding. See Part 3, Section E for more information.

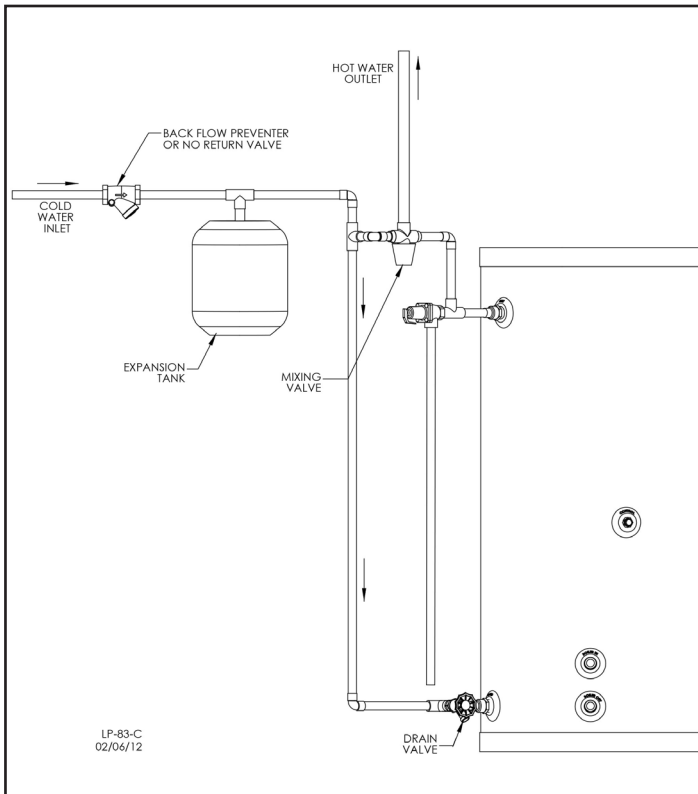

Figure 5 - Expansion Tank Application

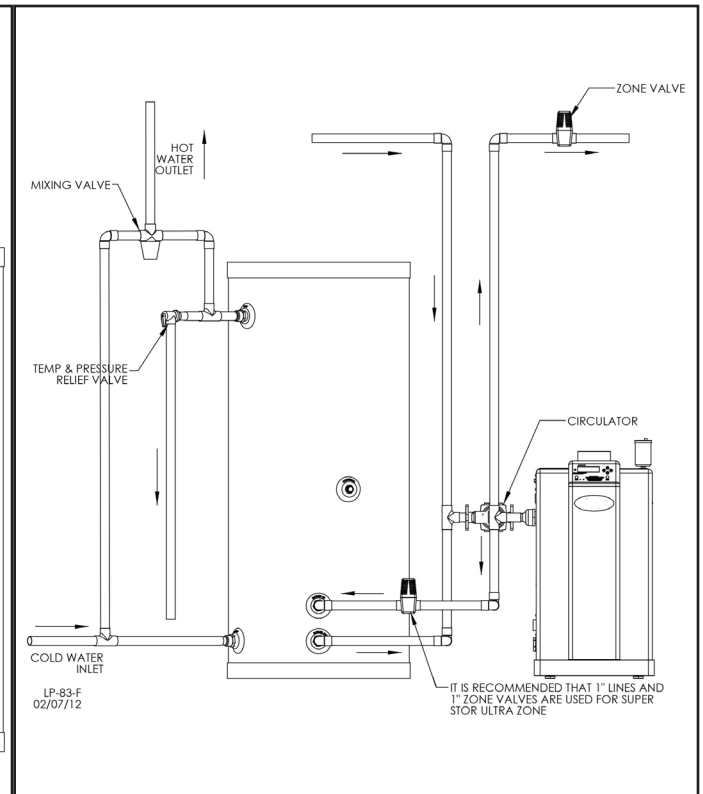

Figure 6 - Installation with High Efficiency Boiler

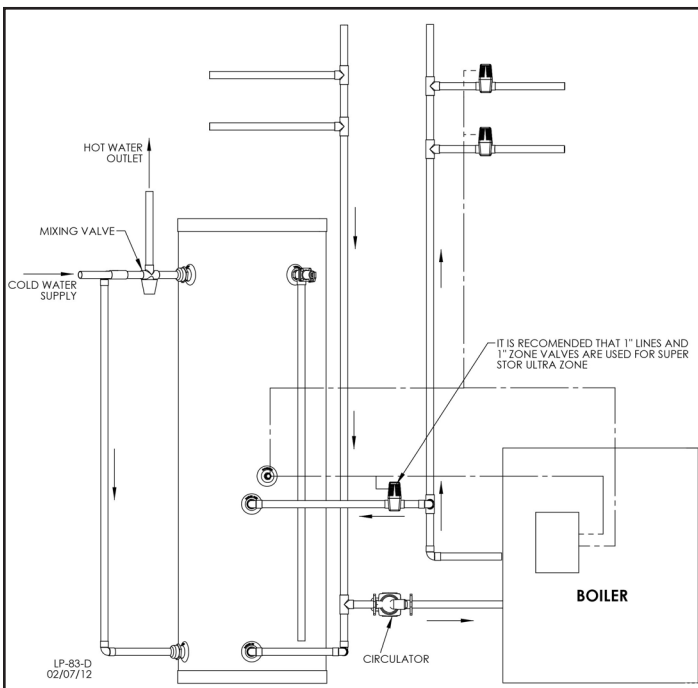

Figure 7 - Zoning with Zone Valves

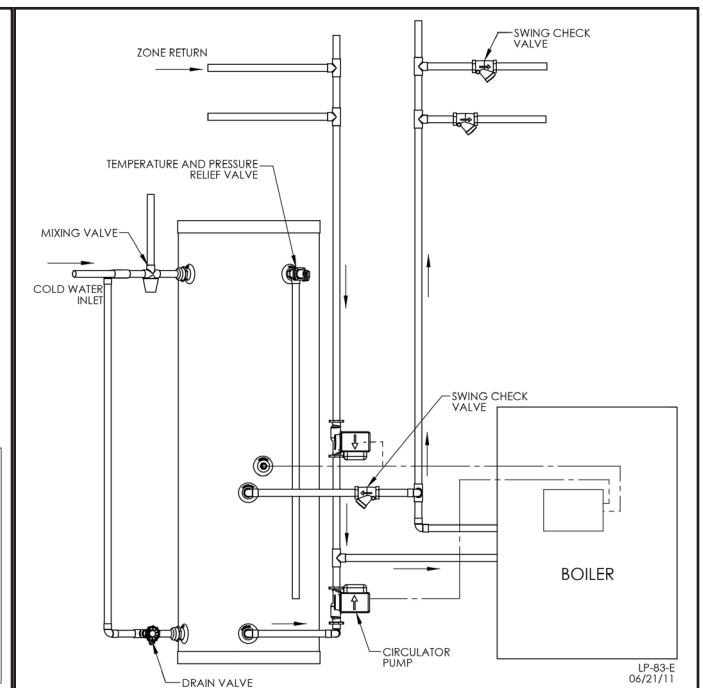

Figure 8 - Zoning with Circulators

NOTES:

1. Minimum pipe size should match connection size. Upsize pipe accordingly if greater flow is required.
2. A thermal expansion tank suitable for potable water must be sized and installed within this piping system between the backflow preventer and the cold water inlet.
3. All circulators should have an integral flow check.
4. Drains and check valve between unit and storage tank will assist in purging air from system.
5. This drawing is meant to demonstrate system piping only. The installer is responsible for all equipment and detailing required by local codes. In Massachusetts, you must install a vacuum relief valve per 248 CMR.
6. Mixing valve application is optional, but recommended to help prevent scalding. See Part 3, Section E for more information.

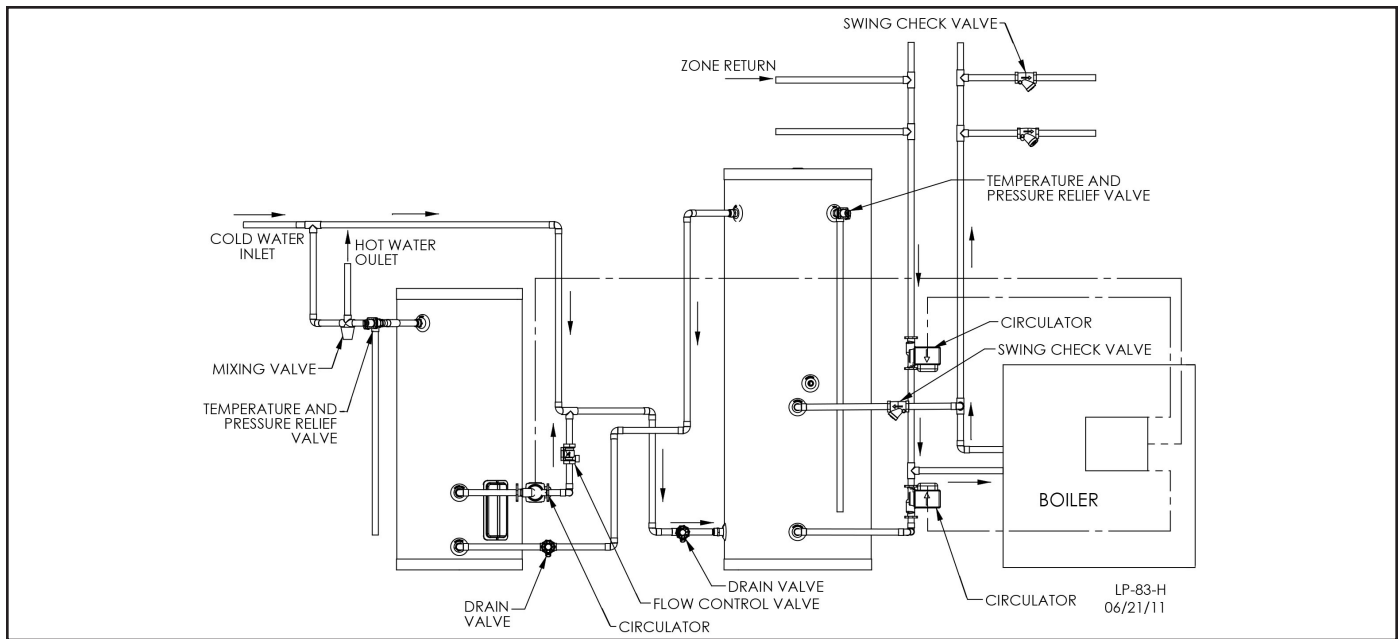

Figure 9 - Installation with Storage Tank

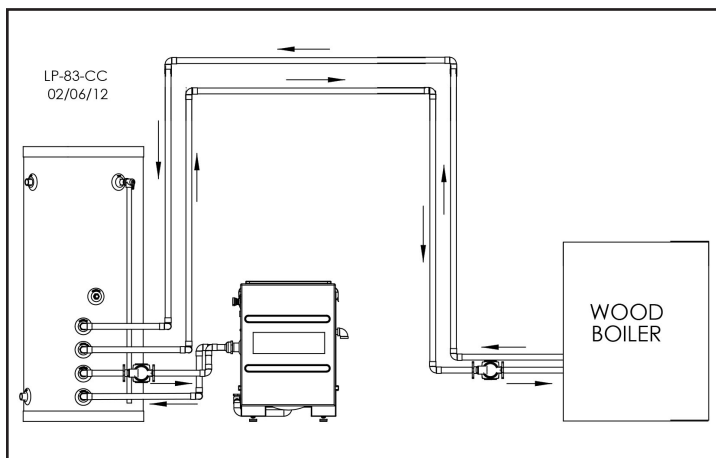

Figure 10 - Dual Purpose Application with Wood Boiler

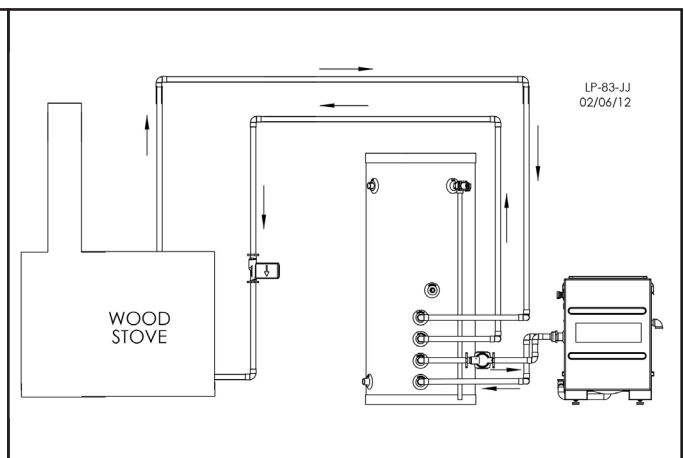

Figure 11 - Dual Purpose Application with Wood Stove

NOTES:

1. Minimum pipe size should match connection size. Upsize pipe accordingly if greater flow is required.
2. A thermal expansion tank suitable for potable water must be sized and installed within this piping system between the backflow preventer and the cold water inlet.
3. All circulators should have an integral flow check.
4. Drains and check valve between unit and storage tank will assist in purging air from system.
5. This drawing is meant to demonstrate system piping only. The installer is responsible for all equipment and detailing required by local codes. In Massachusetts, you must install a vacuum relief valve per 248 CMR.
6. Mixing valve application is optional, but recommended to help prevent scalding. See Part 3, Section E for more information.

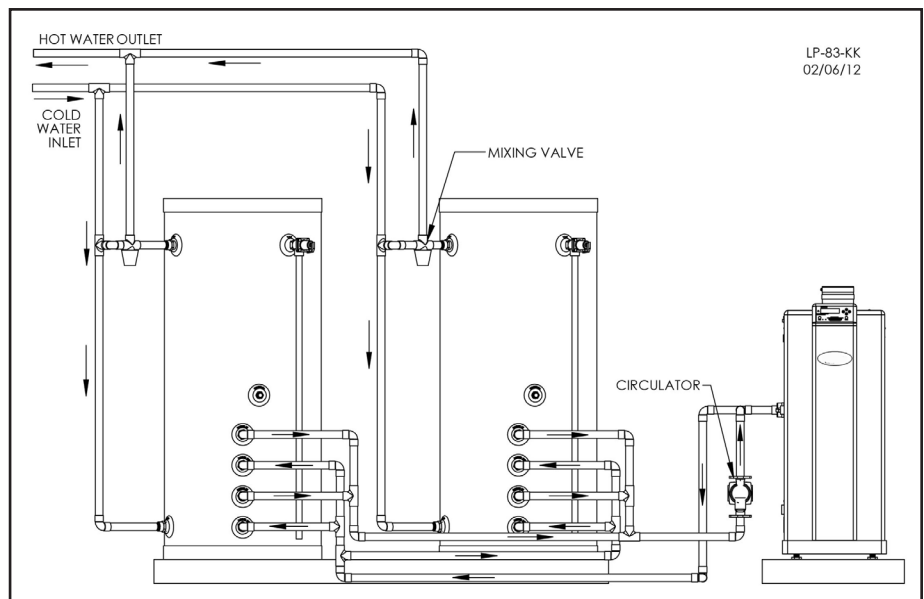

Figure 12 - Dual Purpose Application with Two Water Heaters

NOTES:

1. Minimum pipe size should match connection size. Upsize pipe accordingly if greater flow is required.
2. A thermal expansion tank suitable for potable water must be sized and installed within this piping system between the backflow preventer and the cold water inlet.
3. All circulators should have an integral flow check.
4. Drains and check valve between unit and storage tank will assist in purging air from system.
5. This drawing is meant to demonstrate system piping only. The installer is responsible for all equipment and detailing required by local codes. In Massachusetts, you must install a vacuum relief valve per 248 CMR.
6. Mixing valve application is optional, but recommended to help prevent scalding. See Part 3, Section E for more information.
7. On multiple source applications, use a Honeywell L4081-A-1148, which has two (2) limit settings. This allows the wood stove or solar panel to operate on the tank high setting and the tank low limit setting for conventional boiler back-up.

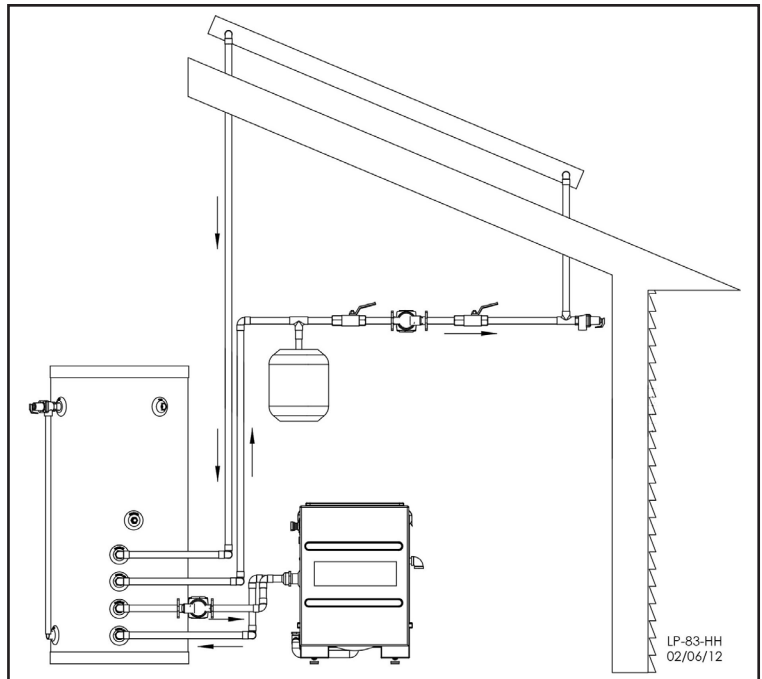

Figure 13 - Dual Purpose Application with Solar Panel

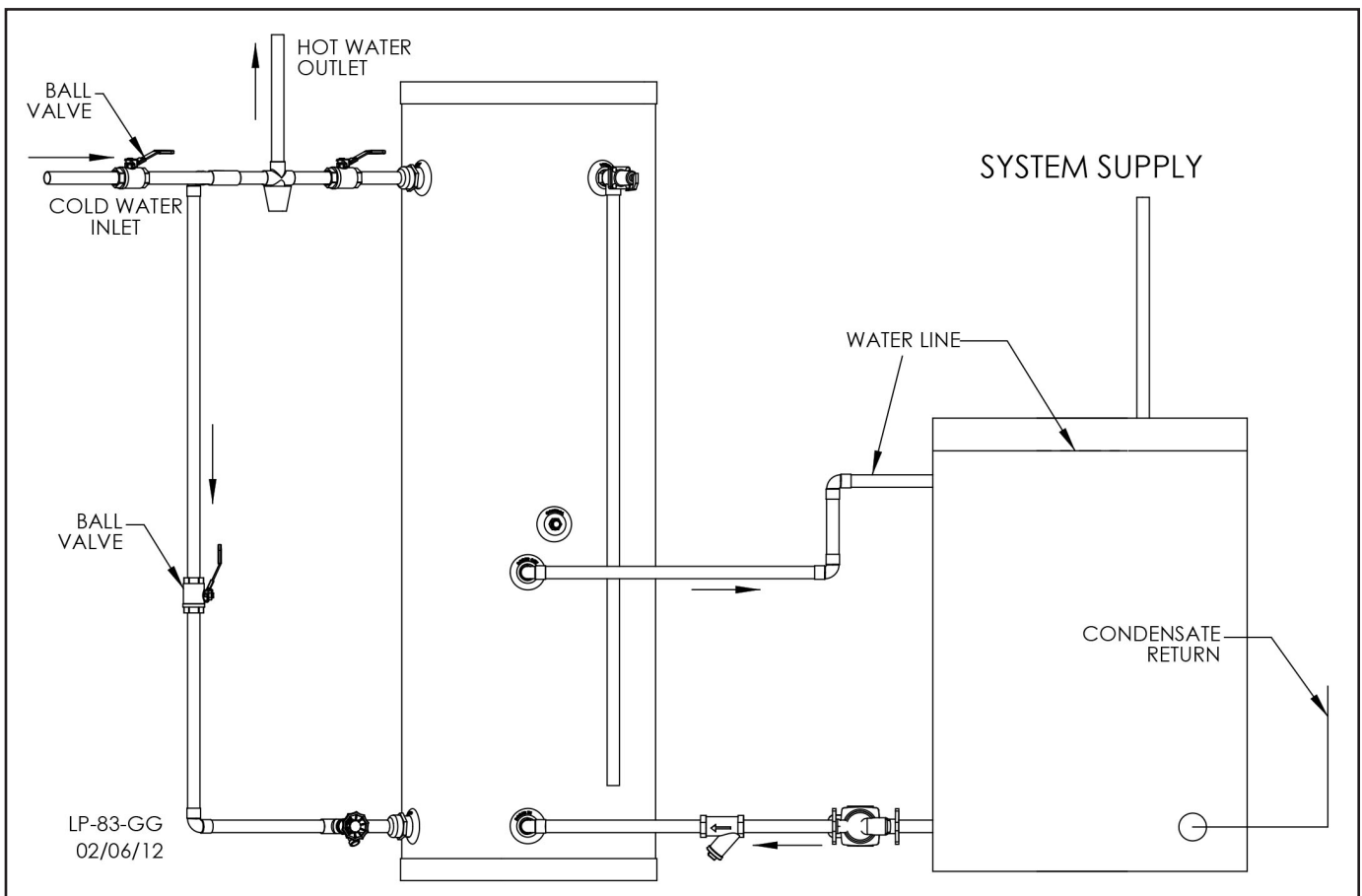

Figure 14 - Steam Boiler

NOTE: On Steam Boiler Applications, the indirect heat exchanger supply and return connections must be below the water line from the boiler connection. The internal flow check or spring check must be used to avoid thermal siphoning from the connected boiler. A basket strainer should also be used to avoid sludge and sediment getting into the pump or heat exchanger.

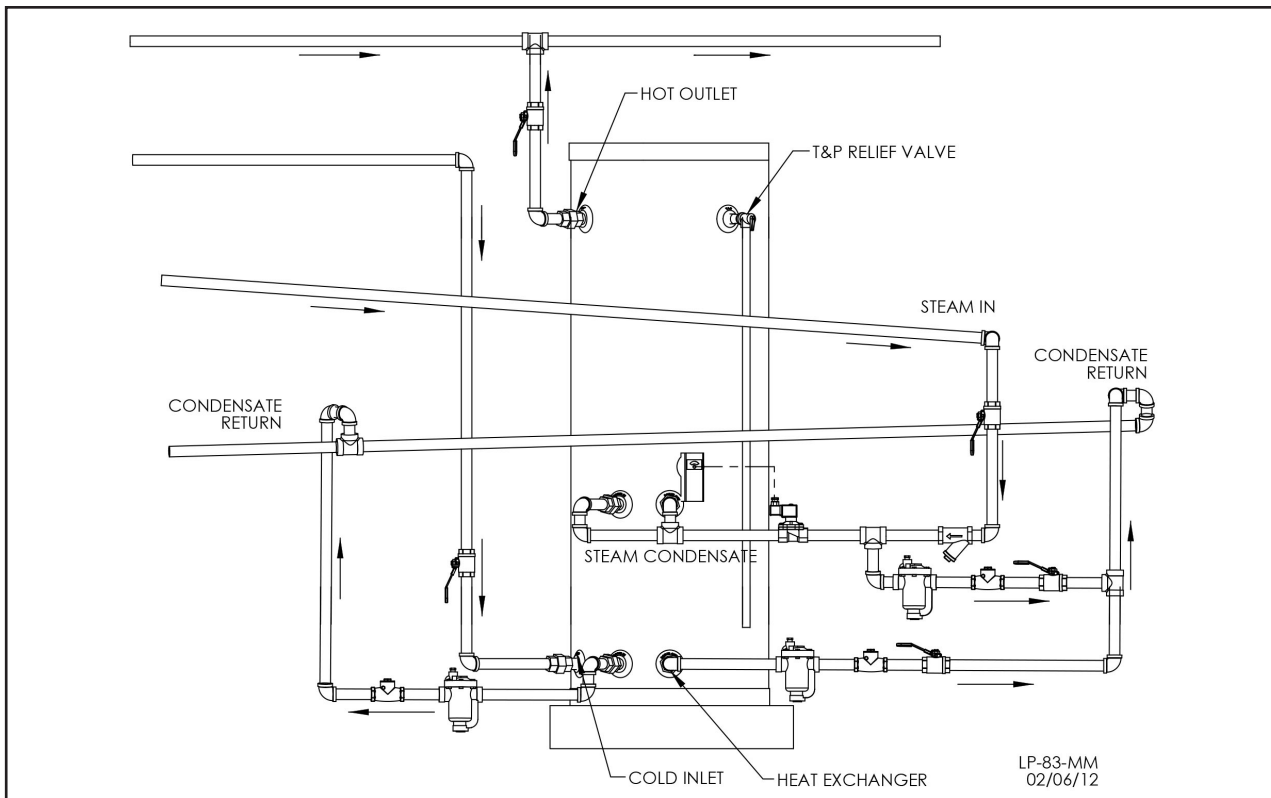

Figure 15 - Live Steam Installation

NOTE: Live Steam Applications are allowed on 80 and 119 gallon SSU / SSU-C models.

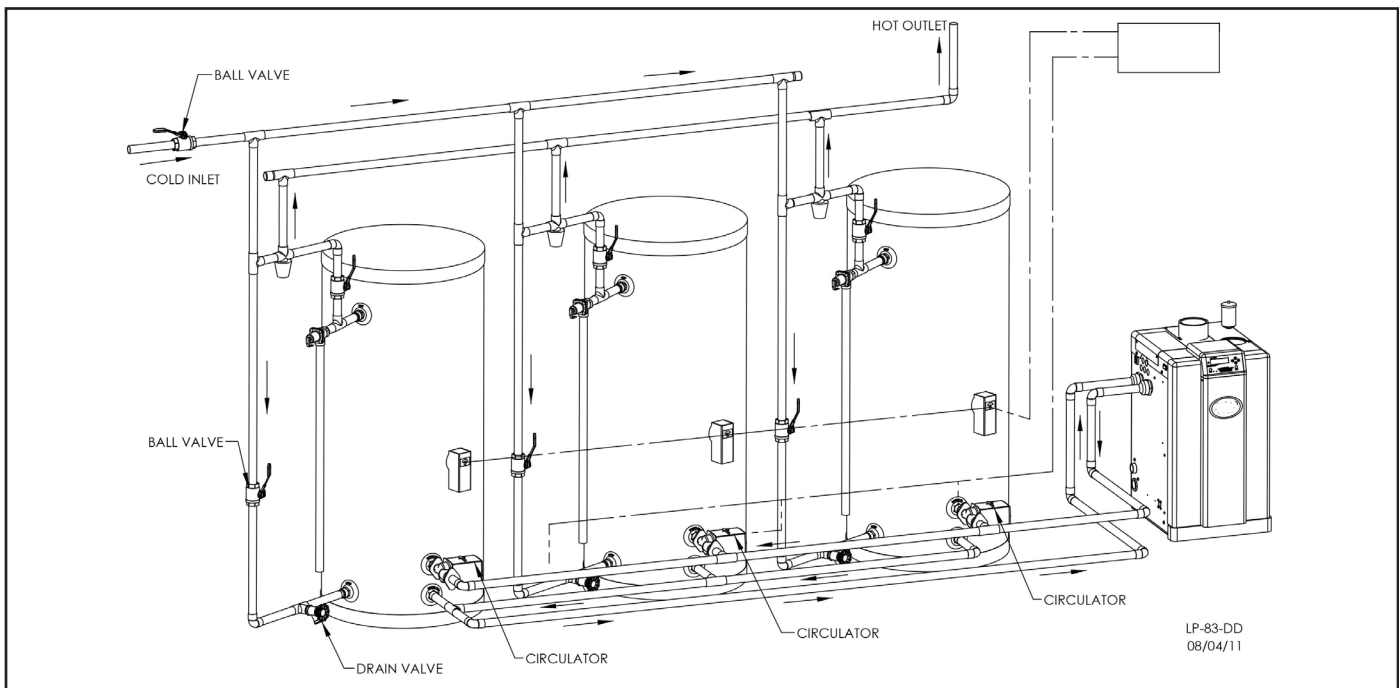

Figure 16 - Multiple Tank Installation

NOTES:

1. Minimum pipe size should match connection size. Upsize pipe accordingly if greater flow is required.
2. A thermal expansion tank suitable for potable water must be sized and installed within this piping system between the backflow preventer and the cold water inlet.
3. All circulators should have an integral flow check.
4. Drains and check valve between unit and storage tank will assist in purging air from system.
5. This drawing is meant to demonstrate system piping only. The installer is responsible for all equipment and detailing required by local codes. In Massachusetts, you must install a vacuum relief valve per 248 CMR.
6. Mixing valve application is optional, but recommended to help prevent scalding. See Part 3, Section E for more information.
7. All piping in parallel used for large dumps of hot water, high usage, and short duration.
8. Massachusetts requires a limit of four (4) tanks per mechanical room. Consult with your local inspector.

Part 4 - Heater Control and Wiring

A. Control

Install control element into well and tighten into place with screws on the control body. Thermal conductive paste is recommended. Once the control is operational, it is important to make sure the control is maintaining the desired operating temperature.

B. Wiring

Wiring is to be done in accordance with all applicable local and state codes. Turn off all power related to the boiler before starting any wiring procedures. It is recommended that a disconnect switch be installed between the boiler control and the water heater.

CAUTION

When wiring the water heater and controls be sure to label all wires to ease future maintenance. Wiring errors can cause improper and dangerous operation.

C. Wiring Diagrams

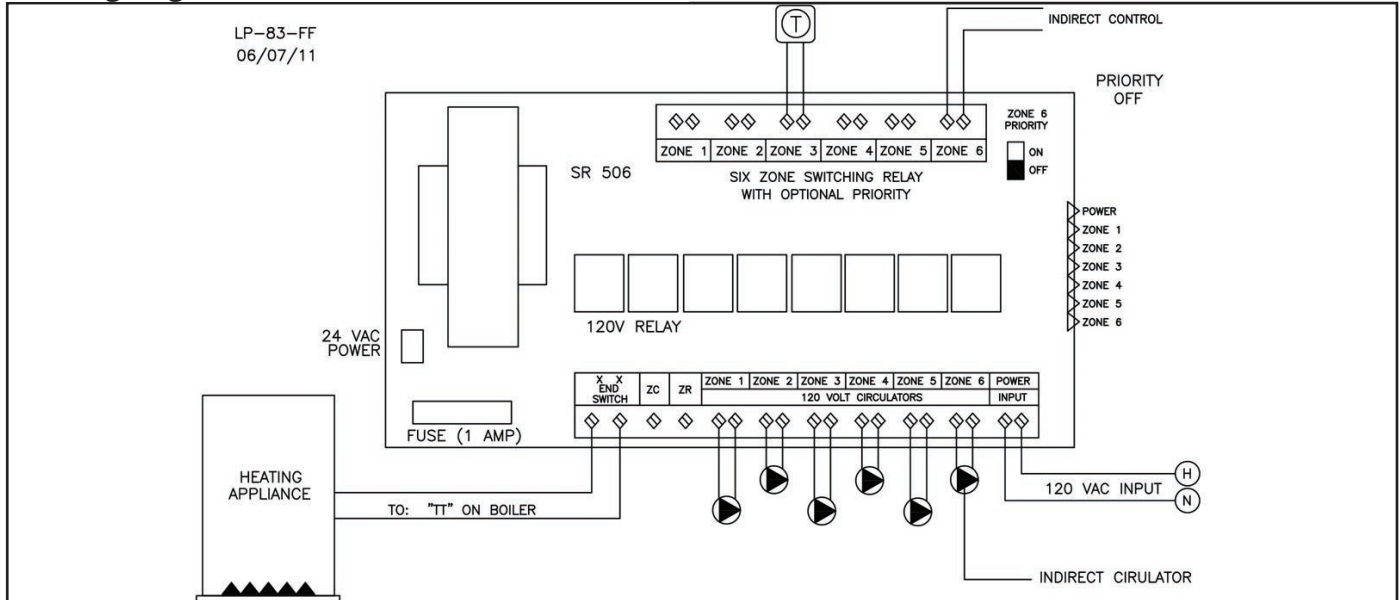

Figure 17 - Wiring with Circulators

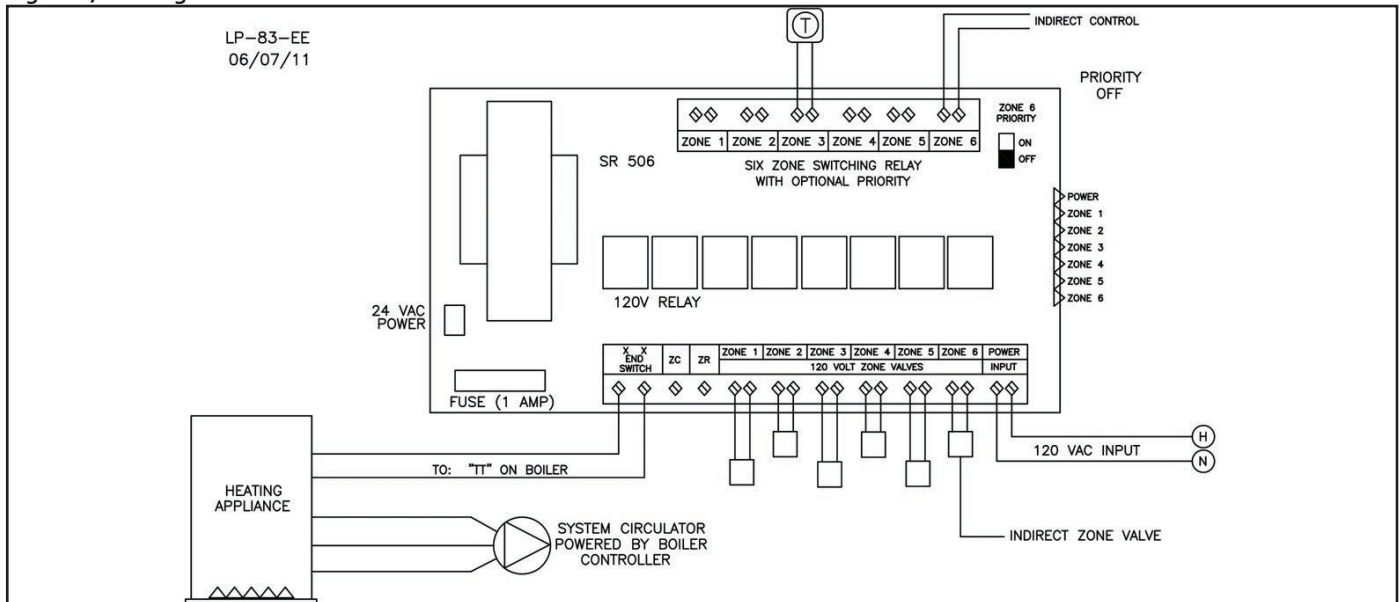

Figure 18 - Wiring with Zone Valves

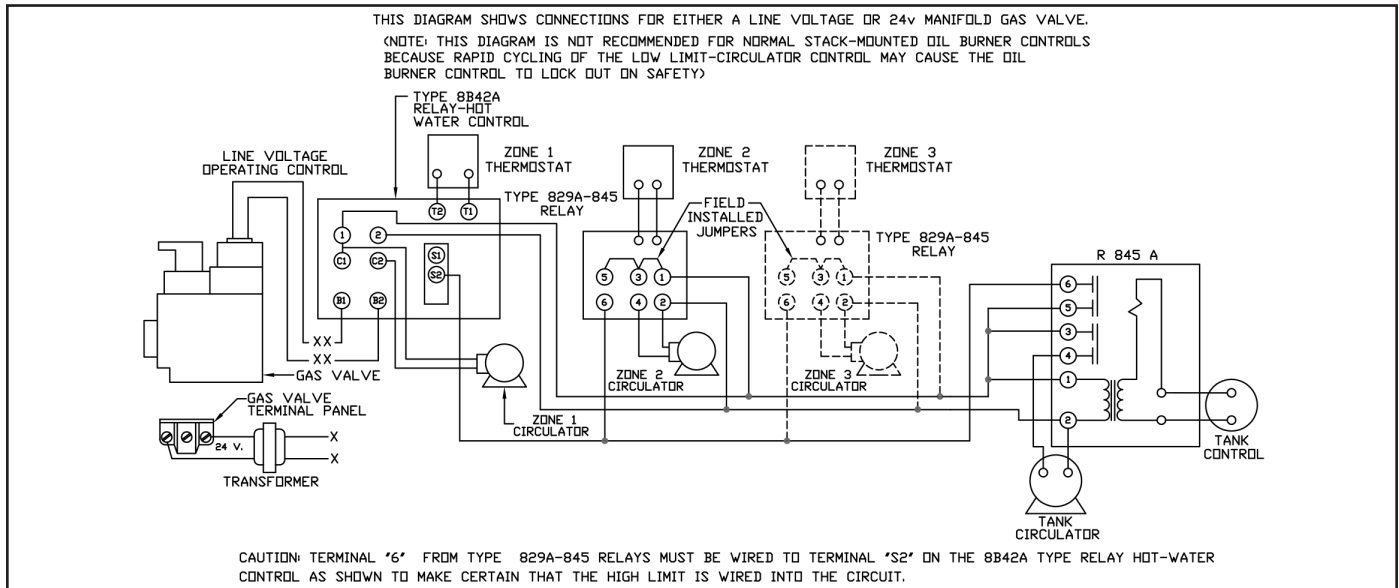

Figure 19 - Zoning with Circulators - R845A Relay

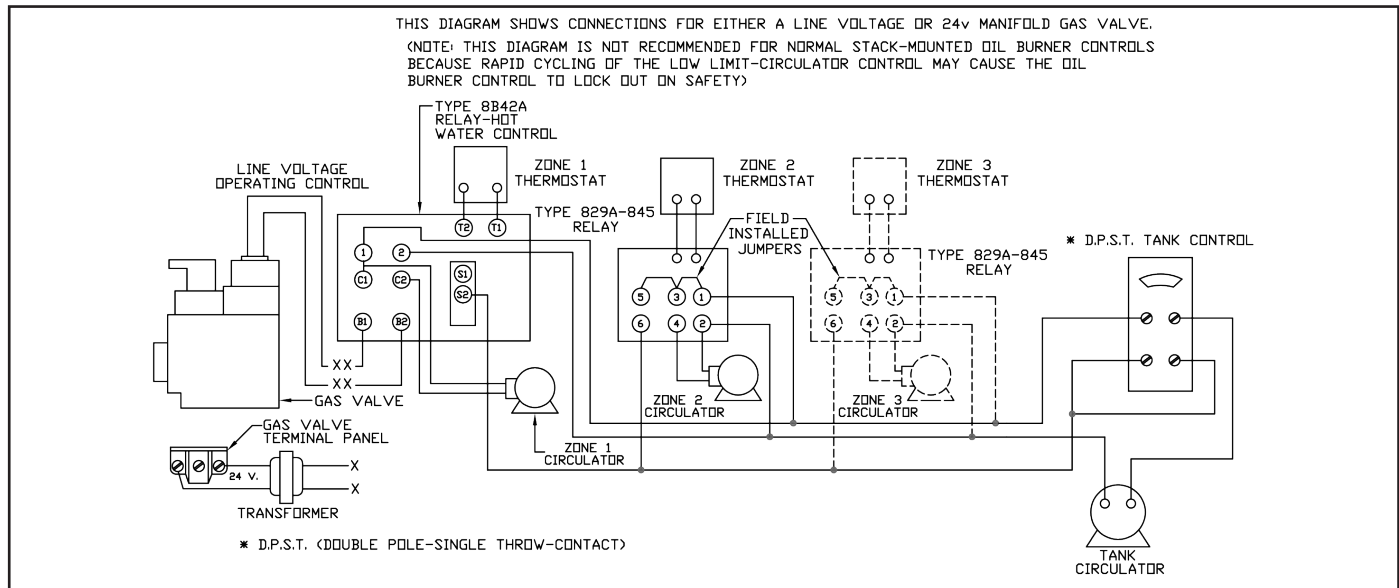

Figure 20 - Zoning with Circulators Using R8182D and DPST - No Relay Required

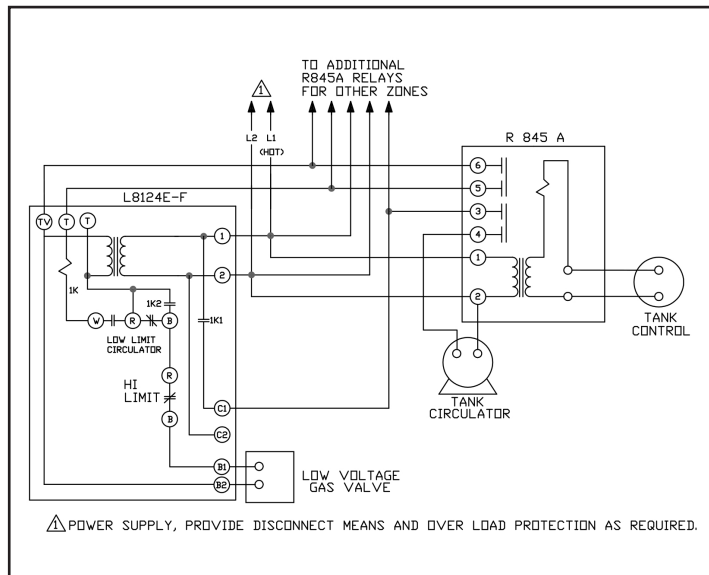

Figure 21 - Zoning with Circulators Using L8124 A, C, and R845A Relay

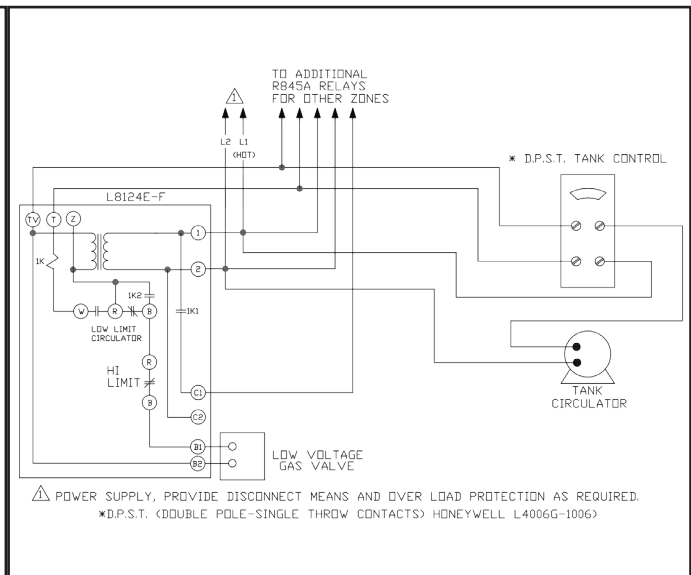

Figure 22 - Zoning with Circulators Using L8124 A, C, and DPST Control - No Relay Required

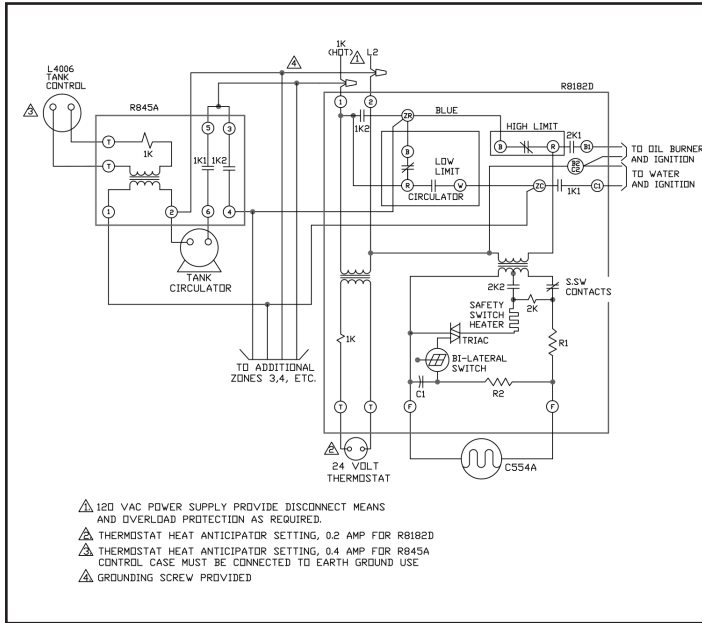

Figure 24 - Zoning with Circulators - R8182D and R845A Relay

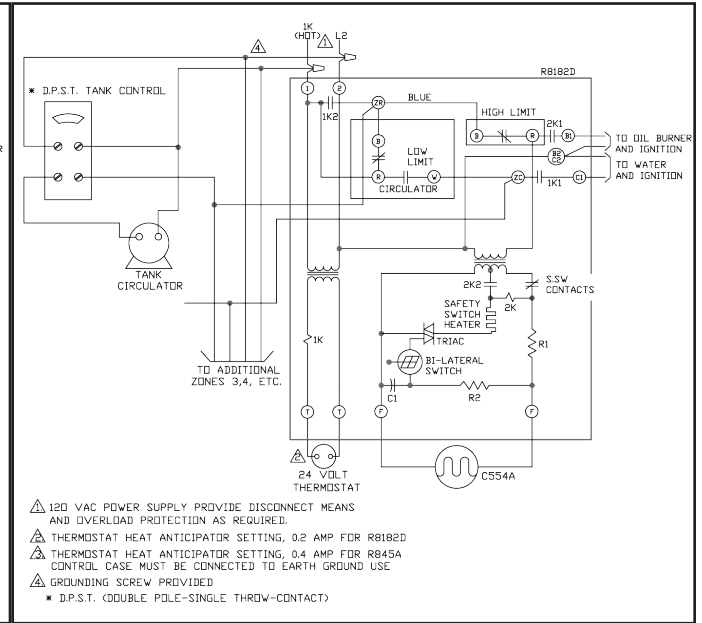

Figure 25 - Control with Built-In DPST Switch - No Relay Required

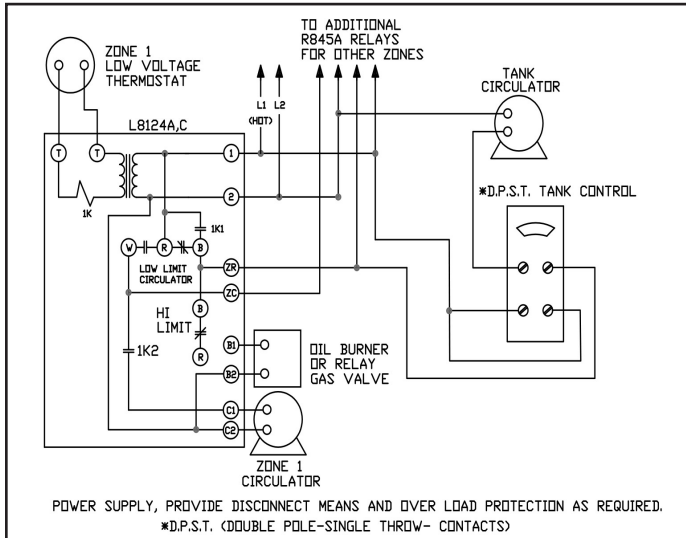

Figure 26 - Zoning with Circulators Using L8124 E-F, and R845A Relay

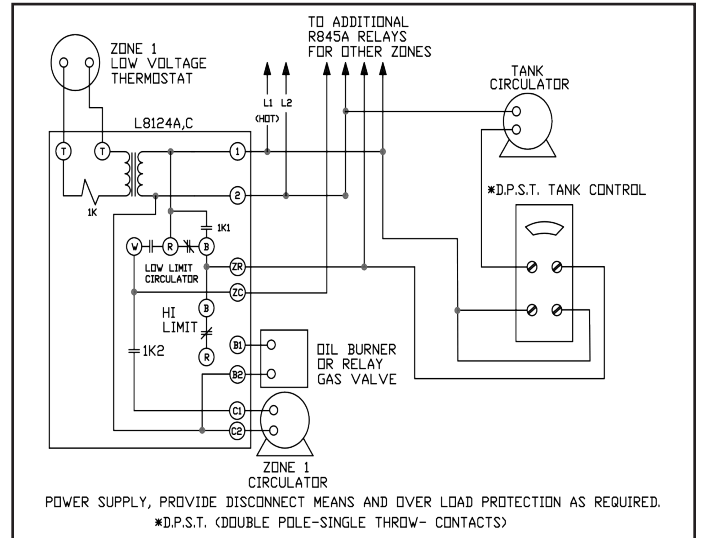

Figure 27 - Zoning with Circulators Using L8124 E-F, and DPST - No Relay Required

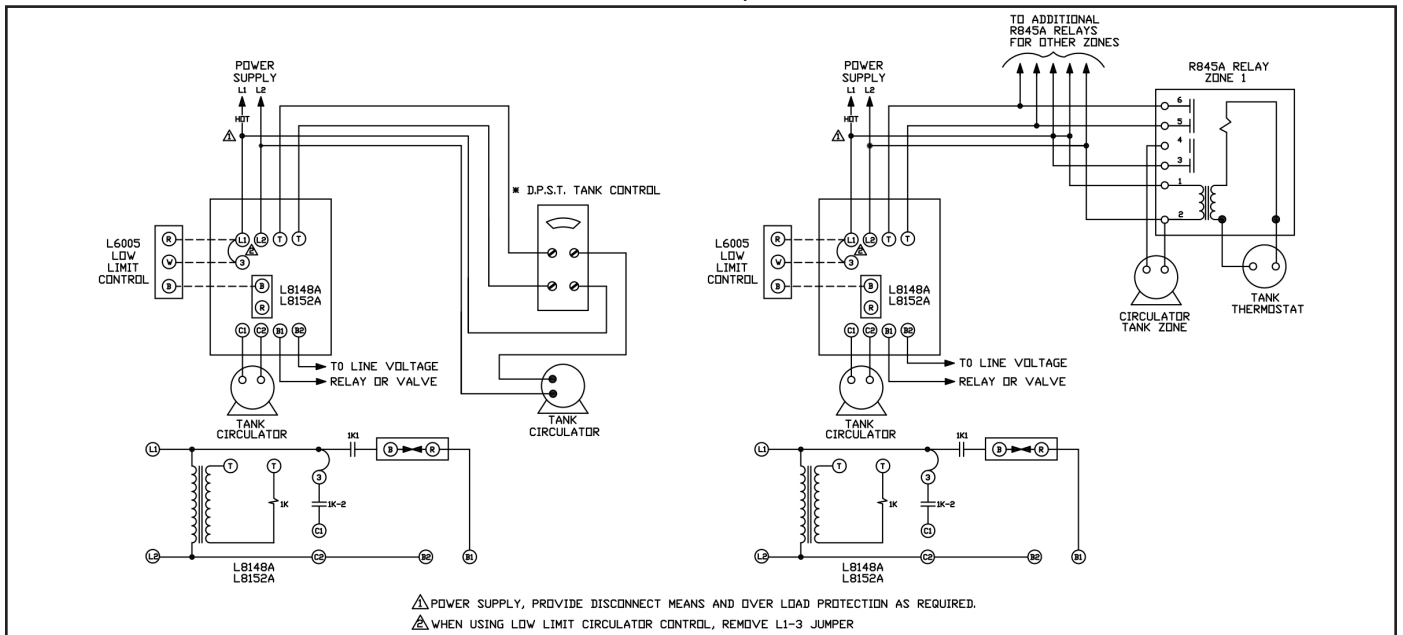

Figure 23 - Using L8148A or L8152A Cold Start Boiler Control with Circulators

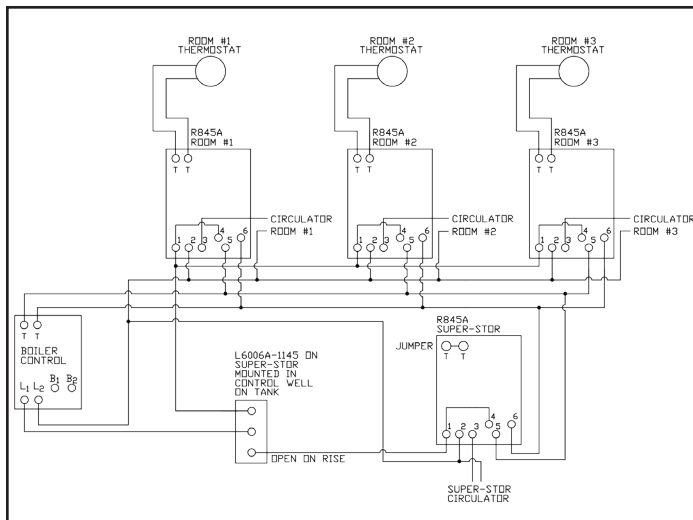

Figure 28 - Priority Zone with Circulators

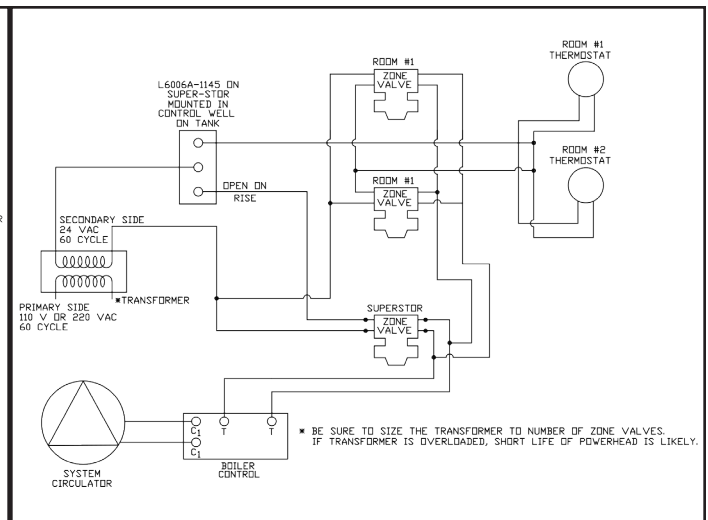

Figure 30 - Priority Zone with Zone Valves

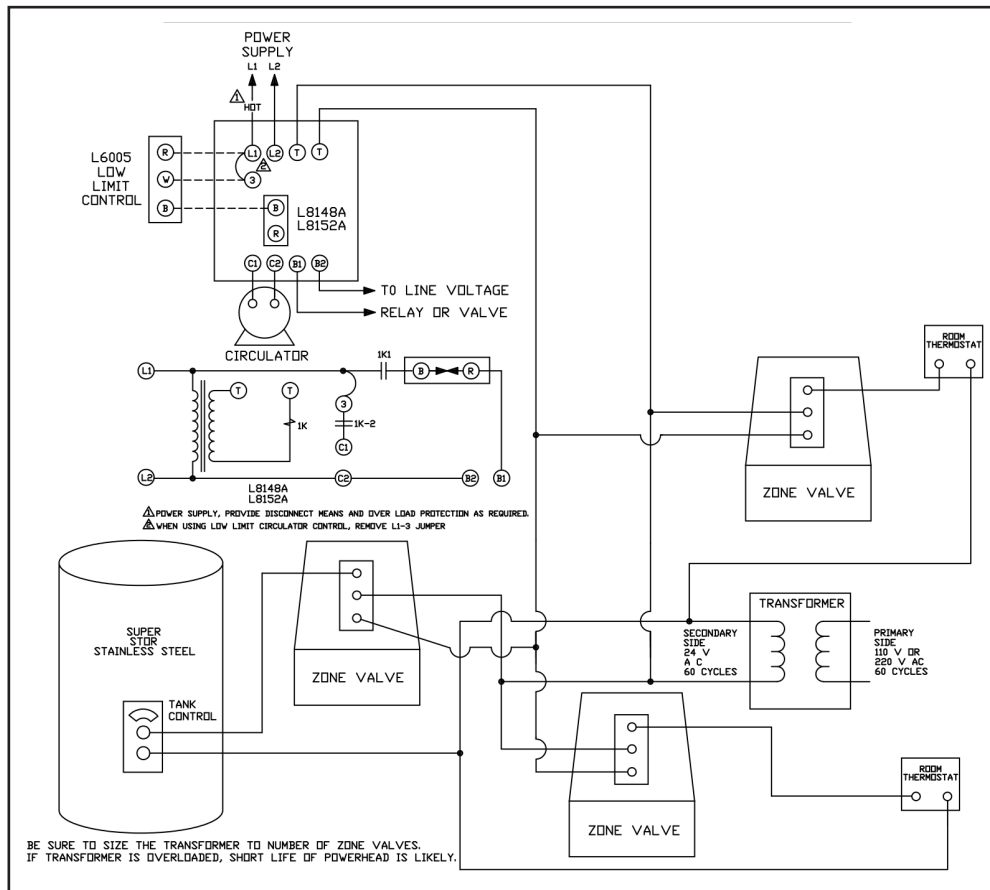

Figure 29 - Using L8148A or L8152A Cold Start Boiler Control with Zone Valves

Part 5 - Start-Up and Operation

1. Fill the water heater by opening the cold water shut-off valve. Purge air from the system by opening a hot water outlet at a fixture in a kitchen or bathroom. When water flows freely from the outlet, the system is purged.

CAUTION

When filling the water heater, open a hot water tap to release air in the tank and piping to ensure proper water heater operation. Failure to ensure the water heater is full before turning on the system will result in damage to the water heater, and could result in property damage. Such damages ARE NOT covered by warranty.

2. Check the system for leaks.

CAUTION

Fix any leaks before continuing the installation. Failure to do so could result in property damage or personal injury.

3. After ensuring there are no leaks within the system, flush the system to clear any soldering residue. Many soldering fluxes contain Zinc Chloride, which can corrode stainless steel.

Draw at least three times the volume of the water heater to properly flush the system.

4. Initiate a call for hot water. Ensure each zone valve or circulator operates only when its thermostat calls for heat. Purge each zone of air to ensure proper operation.

5. Set the water heater to the desired temperature. Boiler high limit should be set at least 20°F higher than the heater temperature. Set the low limit of the boiler control at the minimum setting - this will call the burner on only to satisfy the tank control.

A water heater temperature setting of 120°F is recommended.

However, a lower temperature setting may be required to comply with local and state codes for normal operation. The differential should be set at 10 to 15°F. Installation conditions may require a higher or lower temperature setting. A mixing valve in conjunction with a high temperature setting may be used for high demand applications (spas, hot tubs, whirlpools).

6. When the system is completely flushed, purged of air, and the temperature is set, turn on the boiler. Observe operation. Ensure the boiler shuts down after the indirect water heater set point is satisfied.

⚠ DANGER



Water temperature over 125°F can cause severe burns instantly or death from scalds. Children, disabled and elderly are at highest risk of being scalded.
See instruction manual before setting temperature at water heater.
Feel water before bathing or showering.
Temperature limiting valves are available, see manual.

⚠ WARNING

Risk of scald injury increases as you increase water temperature.

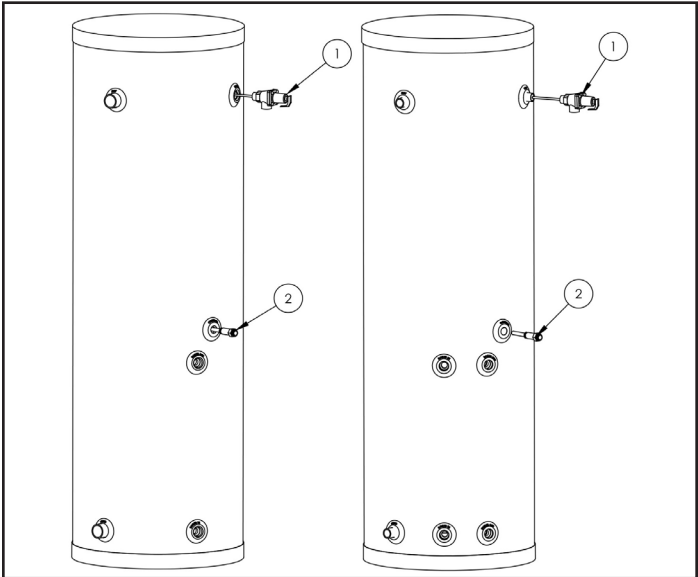

Figure 31 - Replacement Parts

Item #	Part #	Description
1	TP1500	T&P Relief Valve (SSU-20 - SSU-60 and All DW Models) (Not Included with Water Heater)
	TP1400	T&P Relief Valve (SSU-80, SSU-119, and All C Models) (Included with Water Heater)
2	PMW-3SENP-1	Control Well (All Models)

Table 7 - Replacement Parts List

Part 6 - Maintenance and Troubleshooting

Periodic maintenance should be performed by a qualified service technician to ensure all equipment is operating safely and efficiently. The owner should make necessary arrangements with a qualified heating contractor for periodic maintenance of the heater. Installer must also inform the owner that the lack of proper water heater care and maintenance may result in hazardous conditions.

Annual Maintenance Activities		Date Last Completed			
		1st Year	2nd Year	3rd Year	4th Year
Piping					
Near heater piping	Check heater and system piping for any sign of leakage; make sure pipes are properly supported.				
System					
Visual	Do a full visual inspection of all system components. Ensure all components (including boilers, water treatment systems, mixing valves, circulators, etc.) are operating properly and have been maintained.				
Functional	Test all functions of the system. Perform any maintenance required by local codes. Verify system pressure is in the safe operating range.				
Temperatures	Check control for temperature accuracy. *Verify safe settings on Mixing Valve (if installed in system).				
Electrical					
Smoke and CO Detectors	*Verify devices are installed and working properly. Change batteries if necessary.				
Circuit Breakers	Check to see that the circuit breaker is clearly labeled. Exercise circuit breaker.				
Connections	Check wire connections. Make sure they are tight.				
Relief and Drain Valve					
Relief Valve	Lift and release the relief valve on the water heater. Make certain that the valve operates properly by allowing several gallons to flush through the discharge line. Replace if valve is blocked or does not operate properly. NOTE: TAKE CAUTION WHEN OPERATING RELIEF VALVE. DISCHARGED WATER MAY PRESENT A SCALD RISK.				
Drain Valve	Open the drain valve and drain a few quarts of water from the bottom of the tank to flush any hard water deposits. Replace if valve is blocked or does not operate properly. NOTE: TAKE CAUTION WHEN OPERATING DRAIN VALVE. DRAINED WATER MAY PRESENT A SCALD RISK.				
Final Inspection					
Check for Combustibles	Check area around heater for combustible materials such as gasoline or paint thinner. If combustible materials are found, move away from the heater to a safe location.				
Checklist	Verify that you have completed the entire checklist. WARNING: FAILURE TO DO SO COULD RESULT IN SERIOUS INJURY OR DEATH.				
Homeowner	Review what you have done with the homeowner.				
Initial and Date after Inspection / Service. Continue Inspections Annually beyond the Fourth Year.					

Table 8 - Maintenance Activities Checklist - *If Applicable to System

Problem	Reason	Remedy
No Hot Water	Zone Valve Not Opening	Open manually or replace
	Circulator Not Operating	Check or replace
	Tank Control Set Too Low	Raise tank temperature*
	Boiler Control Set Too Low	Raise boiler temperature
	Wiring Incorrect	Check wiring
	Tank Control Failure	Replace control
	Zone Valve Failure	Replace Valve
	Circulator Failure	Replace Circulator
	Air Trap in Loop	Purge Air
Not Enough Hot Water	Zone valve restriction	1" full bore replace zone valve
	Circulator arrow reversed	Reverse circulator
	Tank temperature too low	Raise tank temperature*
	Boiler temperature too low	Raise boiler temperature
	Boiler sized too small	Check sizing chart
	Tank sized too small	
	Demand flow rate too high	Install mixing valve. Raise tank temperature
	Air trap in loop	Purge air
		Install flow regulator
Heat and tank come on together	Check wiring or set indirect as priority over heating	
	Draw tank down and lower thermostat. Recheck.	
T&P Valve Discharges	Tank Temperature Too High	Lower tank temperature
	Water Expands When Heated	Install expansion tank
	Water Pressure Too High	Install pressure reducing valve
Hot Tubs, Spas, Multiple Showers, High Demand	Pressure Too Low	Check line pressure for restriction
	Tank recovery slow	Slow startup boiler. See chart
	Not enough hot water	Boiler sized too small. See chart
		Check flow rate. Compare to chart
	Demand too great. Check flow rates and compare to chart. Install mixing valve and/or flow restricting valve and raise tank and boiler temperature.*	

Table 9 - Troubleshooting - *See scald warning below.

WARNING

The risk of scald injury increases as you increase water temperature. Use a water tempering or mixing valve and extreme caution when using hot water to avoid scald injury. Consult codes for conformance. Failure to follow the instructions in this warning statement could result in serious personal injury or death from scalds.

CAUTION

If draining of the water heater is necessary, open the T&P valve or a hot water tap to prevent vacuum buildup in the tank and piping.

SSU Indirect Fired Water Heater / Solar Water Heater Limited Warranty

For Residential and Commercial Use

HTP warrants each indirect fired water heater and its parts to be free from defects in materials and workmanship according to the following terms, conditions, and time periods. UNLESS OTHERWISE NOTED THESE WARRANTIES COMMENCE ON THE DATE OF INSTALLATION. This limited warranty is only available to the original owner of the indirect fired water heater, and is non-transferable.

Residential Use Warranty (1 year – Parts, Lifetime – Tank)

“Residential” setting shall mean water heater usage in a single family dwelling, or usage in a multiple family dwelling, provided that the water heater services only one (1) dwelling in which the original consumer purchaser resides on a permanent basis and operating temperatures do not exceed 140°F.

Commercial Use Warranty (1 year – Parts, 7 years – Tank)

Water heaters used in a commercial setting shall mean any usage not falling within the definition of a “residential” setting.

COVERAGE

A. During the first year after the original date of installation in the dwelling, HTP warrants that it will repair or replace, at its option, any defective or malfunctioning component of the indirect fired water heater. It is expressly agreed between HTP and the original consumer purchaser that repair or replacement are the exclusive remedies of the original consumer purchaser.

B. 1. Residential Use - During the remaining lifetime of the water heater, HTP will repair or replace, at its option, any water heater having a defect or malfunction that results in a water leak from the outside jacket, inner tank, or heat exchanger as a result of normal use and service. It is expressly agreed between HTP and the original consumer purchaser that repair or replacement are the exclusive remedies of the original consumer purchaser.

2. Commercial Use - During the second through seventh years after the original date of installation, HTP will repair or replace, at its option, any water heater having a defect or malfunction that results in a water leak from the outside jacket, inner tank, or heat exchanger as a result of normal use and service. It is expressly agreed between HTP and the original consumer purchaser that repair or replacement are the exclusive remedies of the original consumer purchaser.

C. Should a defect or malfunction result in a leakage of water within the above-stated warranty periods due to defective material or workmanship, malfunction, or failure to comply with the above warranty, with such defect or malfunction having been verified by an authorized HTP representative, HTP will replace the defective or malfunctioning water heater with a replacement water heater of the nearest compatible model available at the time of replacement.

D. If HTP is unable to repair or replace the water heater so as to conform to this warranty after a reasonable number of attempts, HTP will provide, at its option, a replacement product. These remedies are the consumer purchaser’s exclusive remedies for breach of warranty.

E. Residential Use ONLY - If at the time of a request for service the original consumer purchaser cannot provide a copy of the original sales receipt or the warranty card registration, the warranty period for the water heater shall then be ten (10) years from the date of manufacture of the water heater and NOT the date of installation of the water heater.

F. This warranty extends only to indirect fired water heaters utilized in heating applications that have been properly installed by qualified professionals based upon manufacturer’s installation instructions.

G. Replacement parts will be warranted for 90 days.

OWNER RESPONSIBILITIES

To avoid the exclusion list in this warranty, the owner or installer must:

1. Have a vacuum relief valve and temperature and pressure relief valve bearing the listing marks of the American Society of Mechanical Engineers (ASME) installed with the storage tank assembly in accordance with federal, state, and local codes.
2. Operate the storage tank assembly at pressure below that shown on the rating plate on the pressure relief valve.
3. Keep the storage tank free of damaging scale deposits.
4. Use the water heater in an open system, or in a closed system with a properly sized and installed thermal expansion tank.
5. Make provisions so if the storage tank or any component part or connection thereto should leak, the resulting flow of water will not cause damage to the area in which it is installed.

WARRANTY EXCLUSIONS

This limited warranty will not cover:

1. Any water heater purchased from an unauthorized dealer or online retailer.
2. Any water heater not installed by a qualified heating installer/service technician.
3. Service trips to teach you how to install, use, maintain, or bring the water heater installation into compliance with local building codes and regulations.
4. Failure to locate the water heater in an area where leakage of the tank or water line connections and the combination temperature and relief valve will not result in damage to the area adjacent to the water heater or lower floors of the structure.
5. Any failed components of the heat system not manufactured by HTP as part of the water heater.
6. Water heaters repaired or altered without the prior written approval of HTP.
7. Damages, malfunctions, or failures resulting from failure to install the water heater in accordance with applicable building codes/ordinances or good plumbing and electrical trade practices; or failure to operate and maintain the water heater in accordance with the manufacturer’s provided instructions.
8. Failure or performance problems caused by improper sizing of the water heater, expansion device, or piping.
9. Damages, malfunctions, or failures resulting from improper installation or failure to operate the water heater at pressures not exceeding the working pressure shown on the rating plate.
10. Failure to operate the water heater in an open system, or in a closed system with a properly sized and installed thermal expansion tank.
11. Damages, malfunctions, or failures caused by abuse, accident, fire, flood, freeze, lightning, acts of God and the like.
12. Tank failures (leaks) caused by operating the water heater in a corrosive or contaminated atmosphere.
13. Failure of the heater due to the accumulation of solid materials, lime deposits, or water quality contrary to the manufacturer’s provided instructions. WATER CHEMISTRY REQUIREMENTS – Sodium less than 20mGL. Water pH between 6.0 and 8.0. Hardness less than 7 grains. Chlorine concentration less than 100 ppm.
14. Any damages, malfunctions, or failures resulting from the use of dielectric unions.
15. Components of the water heater that are not defective, but must be replaced during the warranty period as a result of reasonable wear and tear.
16. Production of noise, taste, odors, discoloration, or rusty water.
17. Damages, malfunctions, or failures caused by subjecting the tank to pressures greater than those on the rating label.
18. Water heaters installed outside the fifty states (and the District of Columbia) of the United States of America and Canada.

19. Water heaters moved from the original installation location.
 20. Water heaters that have had their rating labels removed.

PROCEDURES FOR WARRANTY SERVICE REQUESTS

Any claim for warranty assistance must be made promptly. Determine if the water heater is "in-warranty" (that is, within the applicable warranty period) by reviewing a copy of the original sales receipt. You must present a copy of the original sales receipt for a warranty service request.

If your water heater is "in-warranty", contact the retailer from whom the water heater was purchased (or the installer) for assistance. Be prepared to provide the retailer or installer with a copy of your original receipt, complete model and serial numbers, and the date of installation of your water heater, in addition to explanation of your water heater problem.

Warranty coverage is subject to validation of "in-warranty" coverage by HTP claims department personnel. All alleged defective or malfunctioning parts must be returned to HTP via the local distribution channels where original purchase was made. NOTE: Any parts or heaters returned to HTP for warranty analysis will become the property of HTP and will not be returned, even if credit is denied. If all warranty conditions are satisfied, HTP will provide replacement parts to the retailer.

If you have questions about the coverage of this warranty, please contact HTP at the address or phone number stated below:

HTP
 272 Duchaine Blvd
 New Bedford, MA
 02745
 Attention: Warranty Service Department
 1(800) 323-9651

SERVICE, LABOR AND SHIPPING COSTS

This limited warranty does not extend to any shipping charges, delivery expenses, or administrative fees incurred by the purchaser in repairing or replacing the water heater or part(s). This warranty does not extend to labor costs beyond the coverage specified in this warranty document. All such expenses are your responsibility.

LIMITATIONS OF YOUR HTP WARRANTY AND REMEDIES
 THE FOREGOING WARRANTIES ARE EXCLUSIVE AND ARE GIVEN AND ACCEPTED IN LIEU OF ANY AND ALL OTHER WARRANTIES, EXPRESS OR IMPLIED, INCLUDING WITHOUT LIMITATION THE IMPLIED WARRANTIES OF MERCHANTABILITY AND FITNESS FOR A PARTICULAR PURPOSE AND ANY OBLIGATION, LIABILITY, RIGHT, CLAIM OR REMEDY IN CONTRACT OR TORT, WHETHER OR NOT ARISING FROM HTP'S NEGLIGENCE, ACTUAL OR IMPUTED. THE REMEDIES OF THE PURCHASER SHALL BE LIMITED TO THOSE PROVIDED HEREIN TO THE EXCLUSION OF ANY OTHER REMEDIES INCLUDING WITHOUT LIMITATION, INCIDENTAL OR CONSEQUENTIAL DAMAGES, SAID INCIDENTAL AND CONSEQUENTIAL DAMAGES INCLUDING, BUT NOT LIMITED TO, PROPERTY DAMAGE, LOST PROFIT OR DAMAGES ALLEGED TO HAVE BEEN CAUSED BY ANY FAILURE OF HTP TO MEET ANY OBLIGATION UNDER THIS AGREEMENT INCLUDING THE OBLIGATION TO REPAIR AND REPLACE SET FORTH ABOVE. NO AGREEMENT VARYING OR EXTENDING THE FOREGOING WARRANTIES, REMEDIES OR THIS LIMITATION WILL BE BINDING UPON HTP. UNLESS IN WRITING AND SIGNED BY A DULY AUTHORIZED OFFICER OF HTP. THE WARRANTIES STATED HEREIN ARE NOT TRANSFERABLE AND SHALL BE FOR THE BENEFIT OF THE ORIGINAL PURCHASER ONLY.

NO OTHER WARRANTIES

Your HTP warranty gives you specific legal rights, and you may also have other rights that vary from state to state. Some states do not allow the exclusion or limitation of incidental or consequential damages so this limitation or exclusion may not apply to you. These are the only written warranties applicable to the Indirect Fired Water Heater manufactured and sold by HTP. HTP neither assumes nor authorizes anyone to assume for it any other obligation or liability in connection with said Indirect Fired Water Heaters. HTP reserves the right to change specifications or discontinue models without notice.

Customer Installation Record Form	
The following form should be completed by the installer for you to keep as a record of the installation in case of a warranty claim. After reading the important notes at the bottom of the page, please also sign this document.	
Customer's Name	
Date of Installation	
Installation Address	
Product Name / Serial Number(s)	
Comments	
Installer's Code / Name	
Installers Phone Number	
Signed by Installer	
Signed by Customer	

IMPORTANT

Customer: Please only sign after the installer has fully reviewed the installation, safety, proper operation, and maintenance of the system. If the system has any problems please call the installer. If you are unable to make contact, please call your sales representative.

Distributor / Dealer: Please insert contact details.