

SUPPORT MATERIAL FOR XI CLASS PHYSICS

| Sl. No. | Name | Designation |
|----------------|---|--|
| 1. | Sh. Pundrikaksh Kaundinya <i>Group Leader</i> | <i>Vice Principal</i> R.P.V.V., Kishan Ganj, Delhi - 7 |
| 2. | Ms. Girija Shankar <i>Member</i> | <i>P.G.T. (Phy)</i> R.P.V.V., Suraj Mal Vihar, Delhi |
| 3. | Mr. Kulbir Singh Antil <i>Member</i> | <i>P.G.T. (Physics)</i> R.P.V.V., Kishan Ganj, Delhi - 7 |
| 4. | Mr. Devendra Kumar <i>Member</i> | <i>P.G.T. (Physics)</i> R.P.V.V. Yamuna Vihar, Delhi |
| 5. | Dr. K.D. Sharma <i>Member</i> | <i>P.G.T. (Physics)</i> R.P.V.V., Raj Niwas Marg Ludlow Castle, Delhi - 54 |
| 6. | Mr. Mayank <i>Member</i> | <i>P.G.T. (Physics)</i> R.P.V.V., Shalimar Bagh, Delhi |
| 7. | Dr. Shyam Sunder <i>Member</i> | Sr. Lecturer DIET, Karkardooma, Delhi |

CONTENTS

| <i>Unit</i> | <i>Chapter</i> | <i>Page</i> |
|-------------|---|-------------|
| I. | Unit and Measurement | 3 |
| II. | Kinematics | 17 |
| III. | Newton Law of Motion and Friction | 37 |
| IV. | Work Energy and Power | 49 |
| V. | Motion of Systems of Particles and Rigid Body | 66 |
| VI. | Gravitation | 80 |
| VII. | Properties of Bulk Matter | 103 |
| VIII. | Thermodynamics | 138 |
| IX. | Behaviour of Perfect Gas and Kinetic Theory | 154 |
| X. | Oscillations and Waves | 166 |
| | <i>Question Paper</i> | 193 |

UNIT - I

UNIT AND MEASUREMENT

- The dimensions of a physical quantity are the powers to which the fundamental (base) quantities are raised to represent that quantity.
- **Dimensionless Physical Quantities** : Angle, solid angle, relative density, specific gravity, strain, Poisson's ratio, Reynold's number, all trigonometric ratios, refractive index, mechanical efficiency, relative permittivity, dielectric constant, relative permeability, electric susceptibility, magnetic susceptibility.
- The **three main uses** of dimensional analysis are :

- (i) **Conversion of one system of units into another for which we use**

$$n_2 = n_1 \left[\frac{M_1}{M_2} \right]^a \left[\frac{L_1}{L_2} \right]^b \left[\frac{T_1}{T_2} \right]^c$$

where M_1, L_1, T_1 are fundamental units on one system; M_2, L_2, T_2 are fundamental units on the other system; a, b, c are the dimensions of the quantity in mass, length and time; n_1 is numerical value of the quantity in one system and n_2 is its numerical value in the other system.

- (ii) Checking the dimensional correctness of a given physical relation.
- (iii) Derivation of formulae.

- **Principle of Homogeneity of Dimensions** : According to this principle, a correct dimensional equation must be homogeneous, *i.e.*, dimensions of all the terms in a physical expression must be same

$$\text{LHS} = \text{RHS}$$

- **Significant Figures** : In the measured value of a physical quantity, the digits about the correctness of which we are sure plus the last digit which is doubtful, are called the significant figures. For counting significant figures rules are as :

1. All the non-zero digits are significant. In 2.738 the number of significant figures is 4.
 2. All the zeros between two non-zero digits are significant, no matter where the decimal point is, if at all. As examples 209 and 3.002 have 3 and 4 significant figures respectively.
 3. If the measurement number is less than 1, the zero(s) on the right of decimal point and to the left of the first non-zero digit are non-significant. In 0.00807, first three underlined zeros are non-significant and the number of significant figures is only 3.
 4. The terminal or trailing zero(s) in a number without a decimal point are not significant. Thus, 12.3 m = 1230 cm = 12300 mm has only 3 significant figures.
 5. The trailing zero(s) in number with a decimal point are significant. Thus, 3.800 kg has 4 significant figures.
 6. A choice of change of units does not change the number of significant digits or figures in a measurement.
- In any mathematical operation involving addition, subtraction, decimal places in the result will correspond to lowest number of decimal places in any of the numbers involved.
 - In a mathematical operation like multiplication and division, number of significant figures in the product or in the quotient will correspond to the smallest number of significant figures in any of the numbers involved.
 - Problems with *accuracy* are due to errors. The *precision* describes the limitation of the measuring instrument.
 - Difference between measured value and true value of a quantity represents error of measurement.

(i) Mean of n measurements

$$a_{mean} = \frac{a_1 + a_2 + a_3 + \dots + a_n}{n}$$

$$= \frac{1}{n} \sum_{i=1}^n a_i$$

(ii) Mean absolute error

$$[|\Delta a_1| + |\Delta a_2| + |\Delta a_3|$$

$$\Delta a_{\text{mean}} = \frac{[|\Delta a_1| + |\Delta a_2| + |\Delta a_3| + \dots + |\Delta a_n|]}{n}$$

$$= \frac{\sum_{l=1}^n |\Delta a_l|}{n}$$

(iii) Relative error = $\frac{\Delta a_{\text{mean}}}{a_{\text{mean}}}$

(iv) Percentage error = $\frac{\Delta a_{\text{mean}}}{a_{\text{mean}}} \times 100\%$

- The errors are communicated in different mathematical operations as detailed below :

if $\pm \Delta a$, $\pm \Delta b$ and $\pm \Delta x$ are absolute errors in a , b and x respectively, then

(i) for $x = (a + b)$, $\Delta x = \pm [\Delta a + \Delta b]$

(ii) for $x = (a - b)$, $\Delta x = \pm [\Delta a + \Delta b]$

(iii) for $x = a \times b$, $\frac{\Delta x}{x} = \pm \left[\frac{\Delta a}{a} + \frac{\Delta b}{b} \right]$

(iv) for $x = a/b$, $\frac{\Delta x}{x} = \pm \left[\frac{\Delta a}{a} + \frac{\Delta b}{b} \right]$

(v) for $x = \frac{a^n b^m}{c^p}$, $\frac{\Delta x}{x} = \pm \left[n \frac{\Delta a}{a} + m \frac{\Delta b}{b} + p \frac{\Delta c}{c} \right]$

VERY SHORT ANSWER QUESTIONS (1 MARK)

1. Name the strongest force in nature. What is its range?
2. Give two discoveries of Physics used in your daily life.

3. What is the relation between light year and par sec.
4. Give the order of magnitude of the following :
 - (i) size of atom
 - (ii) size of our galaxy.
5. How many kg make 1 unified atomic mass unit?
6. Name same physical quantities that have same dimension.
7. Name the physical quantities that have dimensional formula $[ML^{-1} T^{-2}]$
8. Give two examples of dimension less variables.
9. State the number of significant figures in

| | |
|---------------------------------|---------------------------------|
| (i) 0.007m ² | (ii) 2.64 × 10 ²⁴ kg |
| (iii) 0.2370 g cm ⁻³ | (iv) 0.2300m |
| (v) 86400 | (vi) 86400 m |
10. Given relative error in the measurement of length is .02, what is the percentage error?
11. If a physical quantity is represented by $X = M^a L^b T^{-c}$ and the percentage errors in the measurements of Mm L and T are α , β and γ . What will be the percentage error in X.
12. A boy recalls the relation for relativistic mass^(m) in terms of rest mass (m_0), velocity of particle v , but forgets to put the constant c (velocity of light). He writes $m = \frac{m_0}{(1 - v^2)^{1/2}}$ correct the equation by putting the missing 'c'.
13. Name the technique used in locating.
 - (a) an under water obstacle
 - (b) position of an aeroplane in space.
14. Deduce dimensional formulae of—
 - (i) Boltzmann's constant
 - (ii) mechanical equivalent of heat.
15. Give examples of dimensional constants and dimensionless constants.

SHORT ANSWER QUESTIONS (2 MARKS)

1. What is a physical standard? What characteristics should it have?
2. Define the term unit. Distinguish between fundamental and derived units.
3. Describe the principle and use of SONAR and RADAR.
4. State the principle of homogeneity. Test the dimensional homogeneity of equations—

$$(i) \quad S = ut + \frac{1}{2}at^2$$

$$(ii) \quad S_n = u + \frac{a}{2}(2n - 1)$$

5. In van der Waals's gas equation $\left(P + \frac{a}{v^2}\right)(v - b) = RT$. Determine the dimensions of a and b .
6. Using dimensions convert (a) 1 newton into dynes (b) 1 erg into joules.
7. Magnitude of force experienced by an object moving with speed v is given by $F = kv^2$. Find dimensions of k .
8. A book with printing error contains four different formulae for displacement. Choose the correct formula/formulae

$$(a) \quad y = a \sin \frac{2\pi}{T} t \qquad (b) \quad y = a \sin vt$$

$$(c) \quad y = \frac{a}{T} \sin \left(\frac{t}{a} \right) \qquad (d) \quad y = \frac{a}{T} \left(\sin \frac{2\pi}{T} t + \cos \frac{2\pi}{T} t \right)$$

9. Give limitations of dimensional analysis.
10. For determination of ' g ' using simple pendulum, measurements of length and time period are required. Error in the measurement of which quantity will have larger effect on the value of ' g ' thus obtained. What is done to minimise this error?

SHORT ANSWER QUESTIONS (3 MARKS)

1. Give the name of six Indian Scientists and their discoveries.
2. Name the discoveries made by the following scientists :
 - (a) Faraday
 - (b) Chadwick
 - (c) Hubble
 - (d) Maxwell
 - (e) Newton
 - (f) Bohr.
3. Name the scientific principle on which the following technology is based.
 - (i) Steam engine
 - (ii) Laser
 - (iii) Aeroplane
 - (iv) Rocket propulsion
 - (v) Radio and T.V.
 - (vi) Production of Ultra high magnetic field.
4. Describe a method for measuring the molecular size of Oleic acid.
5. What types of phenomena can be used as a time standard. What are the advantages of defining second in terms of period of radiation from cesium -133 atom.
6. Deduce the dimensional formula for the following quantities
 - (i) Gravitational constant
 - (ii) Yung's modules
 - (iii) Coefficient of viscosity.
7. Define the following units :
 - (i) Light year
 - (ii) Parsec
 - (iii) Astronomical unit (Au)

LONG ANSWER QUESTIONS (5 MARKS)

1. Name the four basic forces in nature. Write a brief note of each. Hence compare their strengths and ranges.
2. Distinguish between the terms precision and accuracy of a measurement.

3. Explain

- (i) absolute error
- (ii) mean absolute error
- (iii) relative error
- (iv) percentage error
- (v) random error

NUMERICALS

1. Determine the number of light years in one metre.
2. The sides of a rectangle are (10.5 ± 0.2) cm and (5.2 ± 0.1) cm. Calculate its perimeter with error limits.
3. The mass of a box measured by a grocer's balance is 2.3 kg. Two gold pieces 20.15 g and 20.17 g are added to the box.
 - (i) What is the total mass of the box?
 - (ii) The difference in masses of the pieces to correct significant figures.
4. 5.74 g of a substance occupies 1.2 cm^3 . Express its density to correct significant figures.
5. If displacement of a body $s = (200 \pm 5)$ m and time taken by it $t = (20 + 0.2)$ s, then find the percentage error in the calculation of velocity.
6. If the error in measurement of mass of a body be 3% and in the measurement of velocity be 2%. What will be maximum possible error in calculation of kinetic energy.
7. The length of a rod as measured in an experiment was found to be 2.48m, 2.46m, 2.49m, 2.50m and 2.48m. Find the average length, absolute error and percentage error. Express the result with error limit.
8. A physical quantity is measured as $a = (2.1 \pm 0.5)$ units. Calculate the percentage error in (i) Q^2 (2) $2Q$.
9. When the planet Jupiter is at a distance of 824.7 million km from the earth, its angular diameter is measured to be $35.72''$ of arc. Calculate diameter of Jupiter.
10. A lesser light beamed at the moon takes 2.56 and to return after reflection at the moon's surface. What will be the radius of lunar orbit.

11. Convert
- $3 \text{ m} \cdot \text{S}^{-2}$ to km h^{-2}
 - $G = 6.67 \times 10^{-11} \text{ N m}^2 \text{ kg}^{-2}$ to $\text{cm}^3 \text{ g}^{-1} \text{ S}^{-2}$
12. A calorie is a unit of heat or energy and it equals 4.2 J where $1 \text{ J} = 1 \text{ kg m}^2 \text{ S}^{-2}$. Suppose we employ a system of units in which unit of mass is α kg, unit of length is β m, unit of time is γ s. What will be magnitude of calorie in terms of this new system.
13. The escape velocity v of a body depends on–
- the acceleration due to gravity 'g' of the planet,
 - the radius R of the planet. Establish dimensionally the relation for the escape velocity.
14. The frequency of vibration of a string depends of on, (i) tension in the string (ii) mass per unit length of string, (iii) vibrating length of the string. Establish dimensionally the relation for frequency.
15. One mole of an ideal gas at STP occupies 22.4 L. What is the ratio of molar volume to atomic volume of a mole of hydrogen? Why is the ratio so large. Take radius of hydrogen molecule to be 1 \AA .

VERY SHORT ANSWER (1 MARK)

- 1 parsec = 3.26 light year
- Size of atom = 10^{-10} m (b) size of galaxy = 10^{22} m
Order = – 10, Order of magnitude = 22.
- $1 \text{ u} = 1.66 \times 10^{-27} \text{ kg}$
- Work, energy and torque.
- Stress, pressure, modulus of elasticity.
- Strain, refractive index.
- (i) 1, (ii) 3, (iii) 4, (iv) 4, (v) 3, (vi) 5 since it comes from a measurement the last two zeros become significant.
- 2%

11. % error in measurement of $X = a\alpha + b\beta + c\gamma$.
12. Since quantities of similar nature can only be added or subtracted, v^2 cannot be subtracted from 1 but v^2/c^2 can be subtracted from 1.

$$\therefore m = \frac{m_0}{\sqrt{1 - v^2/c^2}}$$

13. (a) SONAR → Sound Navigation and Ranging.
 (b) RADAR → Radio Detection and Ranging.
14. (i) Boltzmann Constant :

$$k = \frac{\text{Heat}}{\text{Temperature}} \Rightarrow [k] = \frac{ML^2T^{-2}}{K} = M^1L^2T^{-2}K^{-1}$$

$$(ii) [J] = \left[\frac{\text{Work}}{\text{Heat}} \right] = \frac{M^1L^2T^{-2}}{M^1L^2T^{-2}} = [m^0L^0T^0]$$

15. Dimensional Constants : Gravitational constant, plank's constant.
 Dimensionless Constants : π , e .

SHORT ANSWER (2 MARKS)

4. (i) Dimension of L.H.S. = [s] = $[M^0L^1T^0]$
 Dimension of R.H.S = [ut] + [at²] = $[M^0L^1T^{-1}] + [M^0L^1T^{-2}.T^2]$
 = $M^0L^1T^0$
 \therefore The equation to dimensionally homogeneous.
- (ii) S_n = Distance travelled in nth sec that is $(S_n - S_{nm})$
 $\therefore S_n = u \times t + \frac{a}{2}(2n - 1) \times 1$
 Hence this is dimensionally incorrect.
5. Since dimensionally similar quantities can only be added

$$\therefore [P] = \left[\frac{a}{v^2} \right] \Rightarrow [a] = [Pv^2] = M^1 L^5 T^{-2}$$

$$[b] = [v] = L^3$$

$$7. [k] = \frac{[F]}{[v^2]} = \frac{M^1 L^1 T^{-2}}{[L T^{-1}]^2} = \frac{M^1 L^1 T^{-2}}{M^0 L^2 T^{-2}} = [M^1 L^{-1}]$$

8. The argument of sine and cosine function must be dimensionless so (a) is the probable correct formula. Since

$$(a) y = a \sin\left(\frac{2\pi}{T} t\right) \quad \because \left[\frac{2\pi t}{T}\right] = [T^0] \text{ is dimensionless.}$$

$$(b) y = a \sin \mu t \quad \because [\mu t] = [L] \text{ is dimensional so this equation is incorrect.}$$

$$(c) y = \frac{a}{t} \sin\left(\frac{t}{a}\right) \quad \left[\frac{t}{a}\right] \text{ is dimensional so this is incorrect.}$$

$$(d) y = \frac{a}{t} \left(\sin \frac{2\pi}{T} t + \cos \frac{2\pi t}{T} \right) : \text{ Though } \frac{2\pi t}{T} \text{ is dimensionless } \frac{a}{T} \text{ does not have dimensions of displacement so this is also incorrect}$$

9. Limitation of dimensional analysis :-

1. The value of proportionality constant cannot be obtained
2. Equation containing sine and cosine, exponents, logx etc cannot be analysed.
3. It fails to derive the exact form of physical relation which depends on more than three fundamental quantities
4. It does not tell whether a quantity is scalar or vector.

ANSWERS FOR NUMERICALS

(NUMERICAL)

1. $1 \text{ ly} = 9.46 \times 10^{15} \text{ m}$

$$1 \text{ m} = \frac{1}{9.46 \times 10^{15}} = 1.057 \times 10^{-16} \text{ ly}$$

2. $P = 2(l + b)$

$$= 2(10.5 + 5.2) + 2(0.2 + 0.1)$$

$$= (31.4 + 0.6) \text{ cm}$$

3. (i) Mass of box : 2.3 kg

$$\text{Mass of gold pieces} = 20.15 + 20.17 = 40.32 \text{ g} = 0.04032 \text{ kg.}$$

$$\text{Total mass} = 2.3 + 0.04032 = 2.34032 \text{ kg}$$

In correct significant figure mass = 2.3 kg (as least decimal)

(ii) Difference in mass of gold pieces = 0.02 g

In correct significant figure (2 significant fig. minimum decimal) will be 0.02 g.

4. $\text{Density} = \frac{\text{Mass}}{\text{Volume}} = \frac{5.74}{1.2} = 4.783 \text{ g/cm}^3$

Here least significant figure is 2, so density = 4.8 g/cm³

5. Percentage error in measurement of displacement = $\frac{5}{200} \times 100$

$$\text{Percentage error in measurement of time} = \frac{0.2}{20} \times 100$$

$$\therefore \text{Maximum permissible error} = 2.5 + 1 = 3.5\%$$

6. $\text{K.E.} = \frac{1}{2}mv^2$

$$\therefore \frac{\Delta k}{k} = \frac{\Delta m}{m} + \frac{2\Delta v}{v} \Rightarrow \frac{\Delta k}{k} \times 100 = \frac{\Delta m}{m} \times 100 + 2 \left(\frac{\Delta v}{v} \right) \times 100$$

$$\therefore \text{Percentage error in K.E.} = 3\% + 2 \times 2\% = 7\%$$

7. Average length

$$= \frac{2.48 + 2.46 + 2.49 + 2.50 + 2.48}{5} = \frac{12.41}{5} = 2.48 \text{ m}$$

Mean absolute error

$$\frac{0.00 + 0.02 + 0.01 + 0.02 + 0.00}{5} = \frac{0.05}{5} = 0.013n$$

$$\begin{aligned} \text{Percentage error} &= \frac{0.01}{2.48} \times 100\% = 0.04 \times 100\% \\ &= 0.40\% \end{aligned}$$

$$\text{Correct length} = (2.48 \pm 0.01)\text{m}$$

$$\text{Correct length} = (2.48 \text{ M} \pm 0.40\%)$$

8. $P = Q^2$

$$\frac{\Delta p}{p} = \frac{2\Delta Q}{Q} \quad \left(\frac{0.5}{2.1} \right) = \frac{1.0}{2.1} = 0.476$$

$$\frac{\Delta p}{p} \times 100\% = 47.6\% = 48\%$$

$$R = 2Q$$

$$\frac{\Delta R}{R} = \frac{\Delta Q}{Q} \Rightarrow \frac{0.5}{2.1} = 0.238$$

$$\frac{\Delta R}{R} \times 100\% = 24\%$$

9. $Q = 35.72''$

$$1'' = 4.85 \times 10^{-6} \text{ radian} \Rightarrow = 35.72 \times 4.85 \times 10^{-6}$$

$$\begin{aligned} d = DQ &= 824.7 \times 10^6 \times 35.72 \times 4.85 \times 10^{-6} \\ &= 1.4287 \times 10^5 \text{ km} \end{aligned}$$

10. $t = 2.56 \text{ s}$

$$\therefore t' = \text{time taken by laser beam to go to the man} = \frac{t}{2}$$

$$\begin{aligned} \text{distance between earth and moon} = d &= c \times \frac{t}{2} \\ &= 3 \times 10^8 \times \frac{2.56}{2} \\ &= 3.84 \times 10^8 \text{ m} \end{aligned}$$

$$11. \quad (i) \quad 3 \text{ m s}^{-2} = \left(\frac{3}{1000} \text{ km} \right) \left(\frac{1}{60 \times 60} \text{ hr} \right)^{-2}$$

$$= \frac{3 \times (60 \times 60)^2}{1000} = 3.9 \times 10^4 \text{ km h}^{-2}$$

$$(ii) \quad G = 6.67 \times 10^{-11} \text{ N m}^2 \text{ kg}^{-2}$$

$$= 6.67 \times 10^{-11} (\text{kg m s}^{-2})(\text{m}^2 \text{ kg}^{-2})$$

$$= 6.67 \times 10^{-11} \text{ kg}^{-1} \text{ m}^3 \text{ s}^{-2}$$

$$= 6.67 \times 10^{-11} (1000 \text{ g})^{-1} (100 \text{ cm})^3 (\text{s}^{-2})$$

$$= 6.67 \times 10^{-11} \alpha \frac{1}{1000} \times 100 \times 100 \times 100$$

$$= 6.67 \times 10^{-8} \text{ g}^{-1} \text{ cm}^3 \text{ s}^{-2}$$

$$12. \quad n_2 = n_1 \left[\frac{m_1}{m_2} \right]^a \left[\frac{L_1}{L_2} \right]^b \left[\frac{T_1}{T_2} \right]^c$$

$$= 4.2 \left(\frac{\text{kg}}{\alpha \text{ kg}} \right)^1 \left(\frac{\text{m}}{\beta \text{ m}} \right)^2 \left(\frac{\text{s}}{\text{r s}} \right)^{-2}$$

$$n_2 = 4.2 \alpha^{-1} \beta^{-2} \rho^{+2}$$

$$13. \quad v \propto g^a R^b \quad \mu = k g^a R^b \quad K \rightarrow \text{dimensionless proportionality constant}$$

$$[v] = [g]^a [R]^b$$

$$[M^0 L^1 T^{-1}] = [M^0 L^1 T^{-2}]^a [m^0 L^1 T^0]^b$$

equating powers

$$1 = a + b$$

$$-1 = -2a \Rightarrow a = \frac{1}{2}$$

$$b = 1 - a = 1 - \frac{1}{2} = \frac{1}{2}$$

$$\therefore v = k\sqrt{gR}$$

$$14. \quad n \propto l^a T^b m^c \quad [n] = M^0 L^1 T^0$$

$$[T] = M^1 L^1 T^{-2} \text{ (force)}$$

$$[M] = M^1 L^{-1} T^0$$

$$[M^0 L^1 T^{-1}] = [M^0 L^1 T^0]^a [M^1 L^1 T^{-2}]^b [M^1 L^{-1} T^0]^c$$

$$b + c = 0$$

$$a + b - c = 0$$

$$-2b = -1 \quad b = 1/2$$

$$c = -\frac{1}{2} \quad a = 1$$

$$n \propto \frac{1}{l} \sqrt{\frac{T}{M}}$$

$$15. \quad 1 \text{ A}^0 = 10^{-10} \text{ m}$$

Atomic volume of 1 mole of hydrogen = Avagadrios number \times volume of hydrogen molecule

$$= 6.023 \times 10^{23} \times \frac{4}{3} \times \pi \times (10^{-10})^3$$

$$= 25.2 \times 10^{-7} \text{ m}^3$$

$$\text{Molar volume} = 22.4 \text{ L} = 22.4 \times 10^{-3} \text{ m}^3$$

$$\frac{\text{Molar volume}}{\text{Atomic volume}} = \frac{22.4 \times 10^{-3}}{25.2 \times 10^{-7}} = 0.89 \times 10^4 \approx 10^4$$

This ratio is large because actual size of gas molecule is negligible in comparison to the inter molecular separation.

UNIT II

KINEMATICS

- **One Dimensional Motion.** The motion of an object is said to be one dimensional motion if only one out of the three coordinates specifying the position of the object changes with respect to times.
(an object moves along any of the three axes X, Y or Z).
- **Two dimensional motion.** The motion of an object is said to be two dimensional motion if two out of the three coordinates specifying the position of the object change with respect to time. (the object moves in a plane.)
- **Three dimensional motion.** The motion of an object is said to be three dimensional motion if all the three coordinates specifying the position of the object change with respect to time. (the object moves in space.)
- **Speed.** The speed of an object is defined as the ratio of distance covered and time taken i.e. $\text{speed} = \frac{\text{distance travelled}}{\text{time taken}}$. Speed is a scalar quantity. It can only be zero or positive.
- **Instantaneous velocity.** The velocity of an object at a given instant of time is called its instantaneous velocity. When a body is moving with uniform velocity, its instantaneous velocity = average velocity = uniform velocity.
- **Graphs and Nature**

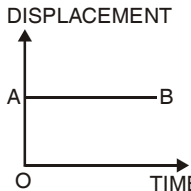
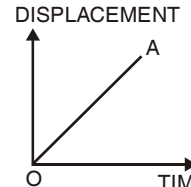
| S.No. | Type of motion | Graph | Features of graph |
|-------|---|---|---|
| ● | For a stationary body, the time displacement graph is a st. line parallel to time axis. |  | The slope of st. line represents instantaneous velocity zero slope \rightarrow zero velocity. |
| ● | When a body, is moving with a constant velocity, then time displacement graph will be a st. line inclined to time axis. |  | Constant slope. Magnitude of velocity is constant. |

- When a body is moving with a constant velocity, the velocity time graph is a st-line parallel to time axis.

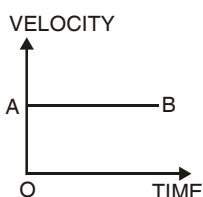

The slope of this graph represents the instantaneous acceleration zero acceleration.

- Relative velocity.** The relative velocity of one object w.r.t another is the velocity with which one object moves w.r.t another object. If \vec{v}_A and \vec{v}_B are the velocity of two objects A and B, and θ is the angle between them, then relative velocity of object A w.r.t B is given by

$$\vec{v}_{AB} = \vec{v}_A - \vec{v}_B \quad \text{where, } v_{AB} = \sqrt{v_A^2 + v_B^2 - 2v_A v_B \cos \theta}$$

and
$$\tan \beta = \frac{v_B \sin \theta}{v_A - v_B \cos \theta}$$

Here, β is the angle which \vec{v}_{AB} makes with the direction of \vec{v}_A .

- Acceleration.** The acceleration of an object is defined as the ratio of change of velocity of the object, and time taken *i.e.*, Acceleration = change in velocity/time taken. Acceleration is a vector quantity. Acceleration is positive, if the velocity is increasing and is negative if velocity is decreasing. The negative acceleration is called **retardation** or **deceleration**.
- Instantaneous acceleration.** The acceleration of an object at a given instant is called its instantaneous acceleration.

$$\text{Instantaneous acceleration, } a = \lim_{\Delta t \rightarrow 0} \frac{\Delta v}{\Delta t} = \frac{dv}{dt} = \frac{d^2x}{dt^2}$$

- Formulae for uniformly accelerated motion along a straight line.**

For accelerated motion

- $v = u + at$
- $s = ut + \frac{1}{2}at^2$
- $v^2 = u^2 + 2as$
- $D_n = u = \frac{a}{2}(2n - 1)$

For Retarded motion

- $v = u - at$
- $s = ut - \frac{1}{2}at^2$
- $v^2 = u^2 - 2as$
- $D_n = u - \frac{a}{2}(2n - 1)$

- **Graphs and nature**

| S.No. | Type of motion | Graph | Features of graph |
|-------|--|-------|--|
| ● | When a body is moving with a constant acceleration the time-displacement graph is a curve with bend upwards. | | The slope of time-displacement curve (instantaneous velocity) increases with time. |
| ● | When a body is moving with a constant retardation, the time-displacement graph is a curve with bend downwards. | | (i) The slope of time-displacement curve (instantaneous velocity) decreases with time. |
| ● | When a body is moving with a constant acceleration and its initial velocity is zero, the velocity-time graph is an oblique st line, passing through origin. | | Greater will be the slope of st. line greater will be the instantaneous acceleration. |
| ● | When a body is moving with a constant acceleration and its initial velocity is not zero, the velocity-time graph is an oblique st-line not passing through origin. | | The area enclosed by the velocity-time graph with time axis represents the distance travelled by the body. |
| ● | When a body is moving with a constant retardation and its initial velocity is not zero, the velocity-time graph is an oblique st. line not passing through origin. | | slope represents acceleration which is negative i.e., retardation. |

- **Scalars.** The quantities which have magnitudes and unit only but no direction. For example, mass, length, time, speed, work, temperature etc.
- **Vector.** The quantities which have magnitudes unit as well as direction and obeys vector laws of addition, multiplication etc. For example, displacement, velocity, acceleration, force, momentum etc.

| S.No. | Resultant | Properties and results |
|-------|---------------------|---|
| ● | Addition of vectors | (i) Only vectors of same nature can be added. (ii) The addition of two vectors \vec{A} and \vec{B} is a resultant \vec{R} , where $R = (A^2 + B^2 + 2AB \cos\theta)^{1/2}$ and $\tan \beta = \frac{B \sin \theta}{A + B \cos \theta}$ where θ is the angle between \vec{A} and \vec{B} and β is the angle which \vec{R} makes with the direction of \vec{A} (iii) Vector addition is commutative <i>i.e.</i> $\vec{A} + \vec{B} = \vec{B} + \vec{A}$ (iv) Vector addition is associative <i>i.e.</i> $(\vec{A} + \vec{B}) + \vec{C} = \vec{A} + (\vec{B} + \vec{C})$ (v) R is maximum if $\theta = 0^\circ$ and is minimum if $\theta = 180^\circ$ |

● **Subtraction of vectors.**

| S.No. | Resultant | Properties and results |
|-------|----------------------------|--|
| ● | Subtraction of two vectors | (i) Only vectors of same nature can be subtracted. (ii) Subtraction of \vec{B} from $\vec{A} =$ vector addition of \vec{A} and $(-\vec{B})$ <i>i.e.</i> $\vec{A} - \vec{B} = \vec{A} + (-\vec{B}) = \vec{R}$ where $R = \sqrt{A^2 + B^2 + 2AB \cos(180^\circ - \theta)}$ and $\tan \beta = \frac{B \sin(180^\circ - \theta)}{A + B \cos(180^\circ - \theta)}$ where θ is the angle between \vec{A} and \vec{B} : and β is the angle which \vec{R} makes with the direction of \vec{A} . (iii) Vector subtraction of two vectors is not commutative <i>i.e.</i> $\vec{A} - \vec{B} \neq \vec{B} - \vec{A}$ (iv) Vector subtraction is not associative <i>i.e.</i> $\vec{A} - (\vec{B} - \vec{C}) \neq (\vec{A} - \vec{B}) - \vec{C}$ |

- **Rectangular components of a vector in a plane.** If \vec{A} makes an angle θ with x-axis and \vec{A}_x and \vec{A}_y be the rectangular components of \vec{A} along x-axis and y-axis respectively, then $\vec{A} = \vec{A}_x + \vec{A}_y = A_x \hat{i} + A_y \hat{j}$

Here $A_x = A \cos\theta$ and $A_y = A \sin\theta$

and $A = (A_x^2 + A_y^2)^{1/2}$ and $\tan\theta = A_y/A_x$

- The dot product of two vectors \vec{A} and \vec{B} , represented by $\vec{A} \cdot \vec{B}$ is a scalar, which is equal to the product of the magnitudes of \vec{A} and \vec{B} and the cosine of the smaller angle between them.

If θ is the smaller angle between \vec{A} and \vec{B} , then $\vec{A} \cdot \vec{B} = AB \cos \theta$

$$(i) \quad \hat{i} \cdot \hat{i} = 1 = \hat{j} \cdot \hat{j} = \hat{k} \cdot \hat{k} = 1$$

$$(ii) \quad \hat{i} \cdot \hat{j} = \hat{j} \cdot \hat{k} = \hat{k} \cdot \hat{i} = 0$$

$$(iii) \quad \text{if } \vec{A} = A_x \hat{i} + A_y \hat{j} + A_z \hat{k} \quad \text{and} \quad \vec{B} = B_x \hat{i} + B_y \hat{j} + B_z \hat{k}$$

- The vector product or cross product of two vectors \vec{A} and \vec{B} is represented as $\vec{A} \times \vec{B}$

If θ is the smaller angle between \vec{A} and \vec{B} , then $\vec{A} \times \vec{B} = \vec{C} = AB \sin \theta \hat{n}$ where \hat{n} is a unit vector perpendicular to the plane containing \vec{A} and \vec{B}

- **Right handed screw rule.** It states that if a right handed screw placed with its axis perpendicular to the plane containing the two vectors \vec{A} and \vec{B} is rotated from the direction of \vec{A} to the direction of \vec{B} through smaller angle, then the sense of the advancement of the tip of the screw gives the direction of $(\vec{A} \times \vec{B})$

For unit vectors : (i) $\hat{i} \times \hat{i} = \hat{j} \times \hat{j} = \hat{k} \times \hat{k} = 0$ and

$$(ii) \quad \hat{i}, \hat{j} \text{ and } \hat{k} : \hat{i} \times \hat{j} = \hat{k}; \hat{j} \times \hat{k} = \hat{i}; \hat{k} \times \hat{i} = \hat{j}$$

$$\text{If } \vec{A} = A_x \hat{i} + A_y \hat{j} + A_z \hat{k} \quad \text{and} \quad \vec{B} = B_x \hat{i} + B_y \hat{j} + B_z \hat{k}$$

$$\vec{A} \times \vec{B} = \begin{vmatrix} \hat{i} & \hat{j} & \hat{k} \\ A_x & A_y & A_z \\ B_x & B_y & B_z \end{vmatrix}$$

- **Projectile.** Projectile is the name given to a body which is thrown with some initial velocity with the horizontal direction and then it is allowed to move under the effect of gravity alone.

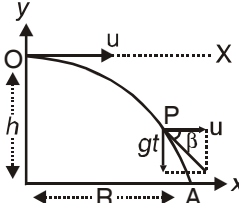
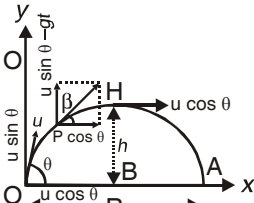
| S.No. | Projectile projected with velocity u | Horizontal projection | Projectile with angular projection |
|-------|---|---|--|
| ● | Path of projectile is a parabola |  |  |
| ● | Velocity of projectile at any instant t | $v = \sqrt{u^2 + g^2 t^2}$ | $v = \sqrt{u^2 + g^2 t^2 - 2ugt \sin \theta}$ |
| ● | Direction of the velocity \vec{v} with the horizontal direction | $\beta = \tan^{-1} \left(\frac{gt}{u} \right)$ | $\beta = \tan^{-1} \left(\tan \theta - \frac{gt}{u \cos \theta} \right)$ |
| ● | Horizontal range | $R = u \sqrt{\frac{2h}{g}}$ | $R = \frac{u^2 \sin 2\theta}{g}$ |
| ● | Time of flight | $t = \sqrt{\frac{2h}{g}}$ | $T = \frac{2u \sin \theta}{g}$ |
| ● | Maximum height | $H = h$ | $H = \frac{u^2 \sin^2 \theta}{2g}$ |

1 MARK QUESTIONS

1. Why can speed of a particle not be negative?
2. Is it possible in straight line motion a particle have zero speed and a non zero velocity?
3. Suggest a situation in which an object is accelerated and have constant speed.
4. Two balls of different masses are thrown vertically upward with same initial velocity. Maximum heights attained by them are h_1 and h_2 respectively what is h_1/h_2 ?
5. A car moving with velocity of 50 kmh^{-1} on a straight road is ahead of a jeep moving with velocity 75 kmh^{-1} . How would the relative velocity be altered if jeep is ahead of car?
6. Which of the two-linear velocity or the linear acceleration gives the direction of motion of a body?

ANSWERS

1. Because speed is distance travelled per second and distance is never negative.
2. No. it is not possible.
3. Uniform circular motion.
4. Same height $\therefore h_1/h_2 = 1$
5. No change
6. Linear velocity

1 MARK

7. Will the displacement of a particle change on changing the position of origin of the coordinate system?
8. If the instantaneous velocity of a particle is zero, will its instantaneous acceleration be necessarily zero.?
9. Can a body subjected to a uniform acceleration always move in the straight line?
10. Write an example of zero vector.
11. State the essential condition for the addition of vectors.
12. When is the magnitude of $(\vec{A} + \vec{B})$ equal to the magnitude of $(\vec{A} - \vec{B})$?
13. What is the maximum number of component into which a vector can be resolved?
14. A body projected horizontally moves with the same horizontal velocity although it moves under gravity. Why?
15. What is the angle between velocity and acceleration at the highest point of a projectile motion?

ANSWERS

7. Will not change.
8. No, (highest point of vertical upward motion under gravity)
9. No example. Projectile motion.
10. The velocity vectors of a stationary object is a zero vectors.
11. They must represent the physical quantities of same nature.
12. When \vec{A} is perpendicular to \vec{B} .
13. Infinite.
14. Because horizontal component of gravity is zero along horizontal direction.
15. 90°

1 MARK

16. When does (i) height attained by a projectile maximum? (ii) horizontal range is maximum?
17. What is the angle between velocity vector and acceleration vector in uniform circular motion?
18. A particle is in clockwise uniform circular motion the direction of its acceleration is radially inward. If sense of rotation or particle is anticlockwise then what is the direction of its acceleration?
19. A train is moving on a straight track with acceleration a . A passenger drops a stone. What is the acceleration of stone with respect to passenger?
20. What is the average value of acceleration vector in uniform circular motion over one cycle?
21. Does a vector quantity depends upon frame of reference chosen?
22. What is the angular velocity of the hour hand of a clock?
23. What is the source of centripetal acceleration for earth to go round the sun?

ANSWERS

16. height is maximum at $\theta = 90$
Range is maximum at $\theta = 45$.
17. 90°
18. Radial inward.
19. $\sqrt{a^2 + g^2}$ where $g =$ Acceleration due to gravity.
20. Null vector.
21. No.
22. $W = \frac{2\pi}{12} = \frac{\pi}{6} \text{ rad h}^{-1}$
23. Gravitation force of sun.

1 MARK

24. What is the unit vector perpendicular to the plane of vectors \vec{A} and \vec{B} ?
25. What is the angle between $(\vec{A} + \vec{B})$ and $(\vec{A} \times \vec{B})$?

ANSWERS

24. $\hat{n} = \frac{\vec{A} \times \vec{B}}{|\vec{A} \times \vec{B}|}$
25. 90°

2 MARKS

1. What are positive and negative acceleration in straight line motion?
2. Can a body have zero velocity and still be accelerating? If yes gives any situation.

- The displacement of a body is proportional to t^3 , where t is time elapsed. What is the nature of acceleration- time graph of the body?
- Suggest a suitable physical situation for the following graph.

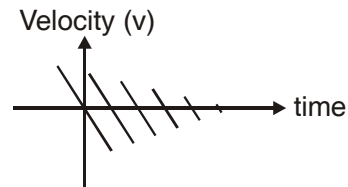

- An object is in uniform motion along a straight line, what will be position time graph for the motion of the object if
 - $x_0 = \text{positive}$, $v = \text{negative}$ $|\bar{v}|$ is constant
 - both x_0 and v are negative $|\bar{v}|$ is constant

where x_0 is position at $t = 0$

ANSWERS

- If speed of an object increases with time, its acceleration is positive. (Acceleration is in the direction of motion) and if speed of an object decreases with time its acceleration is negative (Acceleration is opposite to the direction of motion).
- Yes, at the highest point of vertical upward motion under gravity.
- as $s \propto t^3 \Rightarrow s = kt^3$
 velocity $V = \frac{ds}{dt} = 3kt^2$
 acceleration $a = \frac{dv}{dt} = 6kt$
 i.e $a \propto t$
 \Rightarrow motion is uniform, accelerated motion. $a - t$ graph is straight-line.
- A ball thrown up with some initial velocity rebounding from the floor with reduced speed after each hit.

6.

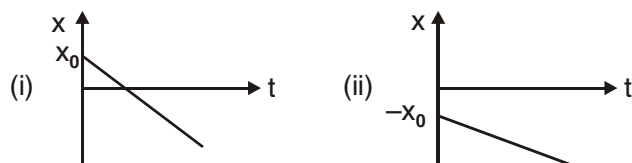

7. A vector \vec{a} is turned through a small angle θ without a change in its length. What are $|\Delta\vec{a}|$ and Δa
8. What will be the effect on horizontal range of a projectile when its initial velocity is doubled keeping angle of projection same?
9. The greatest height to which a man can throw a stone is h . What will be the greatest distance upto which he can throw the stone?
10. A person sitting in a train moving at constant velocity throws a ball vertically upwards. How will the ball appear to move to an observer.
 - (i) Sitting inside the train
 - (ii) Standing outside the train
11. A gunman always keep his gun slightly tilted above the line of sight while shooting. Why?

ANSWERS

7. $|\Delta\vec{a}| = a\theta$ $\Delta a = 0$

8. $R = \frac{u^2 \sin 2\theta}{g} \Rightarrow R \propto u^2$

Range becomes four times.

9. Maximum height ; $H = \frac{u^2 \sin^2 \theta}{2g}$

$\Rightarrow H_{\max} = \frac{u^2}{2g} = h$ (at $\theta = 90^\circ$)

$$\text{Max. Range } R_{\text{max}} = \frac{u^2}{g} = 2h$$

10. (i) Vertical straight line motion
(ii) Parabolic path.
11. Because bullet follow parabolic trajectory under constant downward acceleration.

2 MARKS

12. Is the acceleration of a particle in circular motion not always towards the centre. Explain.

Ans. No, acceleration is towards the centre only in case of uniform circular motion.

3 MARKS

1. Derive the relation

$$S_{\text{nth}} = u + \frac{a}{2}(2n - 1)$$

where S_{nth} = distance travelled in n^{th} second

a = Uniform acceleration

u = Initial speed

2. The velocity time graph for a particle is shown in figure. Draw acceleration time graph from it.

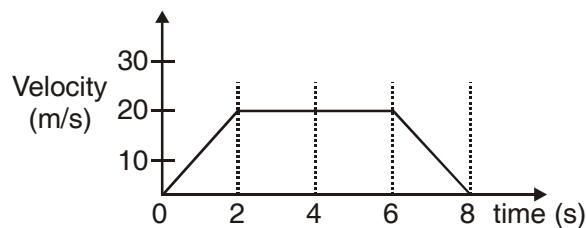

3. Draw position-time graphs of two objects, A and B moving along a straight line, when their relative velocity is
- (i) zero
4. For an object projected upward with a velocity V_0 , which comes back to the same point after some time, draw
- (i) Acceleration-time graph (ii) Position-time graph
- (iii) Velocity-time graph

ANSWERS

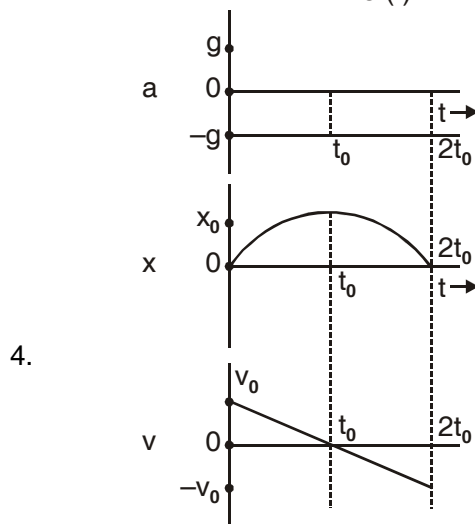
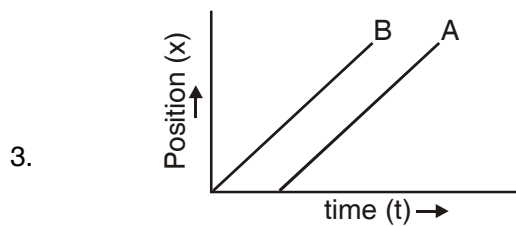
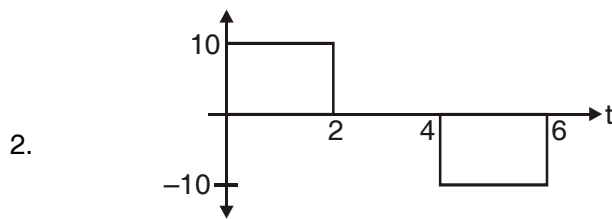

$2t_0 \rightarrow$ total time of the Journey

$x_0 \rightarrow$ highest position.

3 MARKS

5. Two vectors \vec{A} and \vec{B} are inclined to each other at an angle θ . Using triangle law of vector addition, find the magnitude and direction of their resultant.
6. Establish the following vector inequalities :

$$(i) \quad |\vec{a} + \vec{b}| \leq |\vec{a}| + |\vec{b}|$$

$$(ii) \quad |\vec{a} - \vec{b}| \geq |\vec{a}| - |\vec{b}|$$

7. A body is projected at an angle θ with the horizontal. Derive an expression for its horizontal range. Show that there are two angles θ_1 and θ_2 projections for the same horizontal range. such that $\theta_1 + \theta_2 = 90^\circ$
8. Prove that the maximum horizontal range is four times the maximum height attained by the projectile, when fired at an inclination so as to have maximum range.
9. Show that there are two values of time for which a projectile is at the same height. Also show that the sum of these two times is equal to the time of flight.
10. Derive the relation between linear velocity and angular velocity in a uniform circular motion

5 MARKS

1. Derive the following equations of motion for an object moving with constant acceleration along a straight line using graphical method.

$$(i) \quad v = u + at$$

$$(ii) \quad S = ut + \frac{1}{2}at^2$$

$$(iii) \quad v^2 = u^2 + 2as$$

Where symbols have usual meanings.

2. A projectile is fired horizontally with a velocity u . Show that its trajectory is a parabola. Also obtain expression for
 - (i) time of flight
 - (ii) horizontal range
 - (iii) velocity at any instant.
3. Define centripetal acceleration. Derive an expression for the centripetal acceleration of a particle moving with constant speed v along a circular path of radius r .

NUMERICALS

1. The V-t graphs of two objects make angle 30° and 60° with the time axis. Find the ratio of their accelerations.
2. When the angle between two vectors of equal magnitudes is $2\pi/3$, prove that the magnitude of the resultant is equal to either.
3. If $\vec{A} = 3\hat{i} + 4\hat{j}$ and $\vec{B} = 7\hat{i} + 24\hat{j}$, find a vector having the same magnitude as \vec{B} and parallel to \vec{A} .
4. What is the angle made by vector $\vec{A} = 2\hat{i} + 2\hat{j}$ with x-axis?
5. What is the vector sum of n coplanar forces, each of magnitude F , if each force makes an angle of $\frac{2\pi}{n}$ with the preceding force?
7. A car is moving along x-axis. As shown in figure it moves from O to P in 18 seconds and return from P to Q in 6 second. What are the average velocity and average speed of the car in going from
 - (i) O to P
 - (ii) from o to P and back to Q.

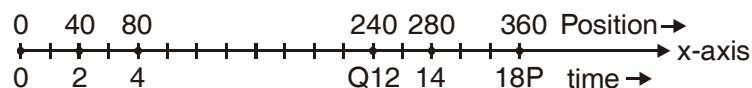

ANSWER

$$1. \frac{a_1}{a_2} = \frac{\tan 30}{\tan 60} = \frac{1/\sqrt{3}}{\sqrt{3}} = \frac{1}{3} \Rightarrow 1 : 3$$

$$\begin{aligned} 2. R &= (P^2 + Q^2 + 2PQ \cos\theta)^{1/2} \\ &= \left(P^2 + P^2 + 2P \cdot P \cos \frac{2\pi}{3} \right)^{1/2} \\ &= \left[2P^2 + 2P^2 \left(\frac{-1}{2} \right) \right]^{1/2} = P \end{aligned}$$

$$3. |\vec{A}| = \sqrt{3^2 + 4^2} = 5$$

$$\hat{A} = \frac{\vec{A}}{|\vec{A}|} = \frac{3\hat{i} + 4\hat{j}}{5}$$

$$\text{also } |\vec{B}| = \sqrt{7^2 + 24^2} = 25$$

$$\begin{aligned} \text{desired vector} &= |\vec{B}| \hat{A} = 25 \frac{(3\hat{i} + 4\hat{j})}{5} \\ &= 5(3\hat{i} + 4\hat{j}) = 15\hat{i} + 20\hat{j} \end{aligned}$$

$$4. \theta = \tan^{-1} \frac{2}{2} = 45^\circ$$

5. Resultant force is zero.

7. (i) o to p Average velocity = 20 ms^{-1}

average speed = 20 ms^{-1}

(ii) o to P and back to Q

Average velocity = 10 ms^{-1}

Average speed = 20 ms^{-1}

NUMERICALS

8. On a 60 km straight road, a bus travels the first 30 km with a uniform speed of 30 kmh^{-1} . How fast must the bus travel the next 30 km so as to have average speed of 40 kmh^{-1} for the entire trip?
9. The displacement x of a particle varies with time as $x = 4t^2 - 15t + 25$.
Find the position, velocity and acceleration of the particle at $t = 0$.
10. A driver take 0.20 second to apply the breaks (reaction time). If he is driving car at a speed of 54 kmh^{-1} and the breaks cause a deceleration of 6.0 ms^{-2} . Find the distance travelled by car after he sees the need to put the breaks.
11. A body covers 12 m in 2nd second and 20 m in 4th second. How much distance will it cover in 4 seconds after the 5th second.
12. A ball thrown vertically upwards with a speed of 19.6 ms^{-1} from the top of a tower returns to the earth in 6s. Find the height of the tower ($g = 9.8 \text{ m/s}^2$)
13. Two town A and B are connected by a regular bus service with a bus leaving in either direction every T min. A man cycling with a speed of 20 kmh^{-1} in the direction A to B notices that a bus goes past him every 18 min in the direction of his motion, and every 6 min in the opposite direction. What is the period T of the bus service and with what speed do the buses ply of the road?

ANSWER

$$8. \quad V_{\text{avg}} = \frac{S_1 + S_2}{t_1 + t_2} = \frac{St S}{S \left(\frac{1}{V_1} + \frac{1}{V_2} \right)} = \frac{2 V_1 V_2}{V_1 + V_2}$$

$$\text{or} \quad 40 = \frac{2 \times 30 \times v_2}{V_1 + V_2} \Rightarrow V_2 = 60 \text{ kmh}^{-1}$$

9. position $x = 25 \text{ m}$

$$\text{velocity } V = \frac{dx}{dt} / t = 0 = -15 \text{ ms}^{-1}$$

$$\text{acceleration } a = \frac{dv}{dt} = 8 \text{ ms}^{-2}$$

10. (distance covered during 0.20 s) +
(distance covered until rest)
= $(15 \times 0.20) + [18.75] = 21.75 \text{ m}$

11. $S_{2\text{nd}} = u + \frac{a}{2}(2 \times 2 - 1) \Rightarrow 4 + \frac{3}{2}a = 12$

$S_{4\text{th}} = u + \frac{a}{2}(2 \times 4 - 1) \Rightarrow 4 + \frac{7}{2}a = 20$

$\Rightarrow u = 6\text{ms}^{-1}$ and $a = 4\text{ms}^{-1}$

According to question = $5g - 5_s \left(s = ut + \frac{1}{2}at^2 \right)$

= 136 m

12. using $s = ut + \frac{1}{2}at^2$

$-h = 19.6 \times 6 + \frac{1}{2} \times (-9.8) \times 62$

$h = 58.8 \text{ m}$

13. $V = 40 \text{ kmh}^{-1}$ and $T = 9 \text{ min}$

NUMERICALS

14. A motorboat is racing towards north at 25 kmh^{-1} and the water current in that region is 10 kmh^{-1} in the direction of 60° east of south. Find the resultant velocity of the boat.

15. An aircraft is flying at a height of 3400 m above the ground. If the angle subtended at a ground observation point by the aircraft position 10 second apart is 30° , what is the speed of the aircraft?

16. A boat is moving with a velocity $(3\hat{i} - 4\hat{j})$ with respect to ground. The water in river is flowing with a velocity $(-3\hat{i} - 4\hat{j})$ with respect to ground.

What is the relative velocity of boat with respect to river?

17. A hiker stands on the edge of a cliff 490 m above the ground and throws a stone horizontally with an initial speed of 15 m s^{-1} . Neglecting air resistance, find the time taken by the stone to reach the ground and the speed with which it hits the ground ($g = 9.8 \text{ ms}^{-2}$)
18. A bullet fired at an angle of 30° with the horizontal hits the ground 3 km away. By adjusting the angle of projection, can one hope to hit the target 5 km away? Assume that the muzzle speed to be fixed and neglect air resistance.

ANSWER

14. $V = 21.8 \text{ kmh}^{-1}$
 angle with north $\theta = 23.4^\circ$

15. Speed = 182.2 ms^{-1}

16. $\vec{V}_{BW} = \vec{V}_B - \vec{V}_W$
 $= 6\hat{i} + 8\hat{j}$

17. time = 10 seconds

$$V = \sqrt{V_x^2 + V_y^2} = \sqrt{15^2 + 98^2} = 99.1 \text{ ms}^{-1}$$

18. Maximum Range = 3.46 km

So it is not possible.

NUMERICALS

19. A stone tied to the end of a string 80 cm long is whirled in a horizontal circle with a constant speed. If the stone makes 14 revolutions in 25 seconds, what is the magnitude and direction of acceleration of the stone?
20. A cyclist is riding with a speed of 27 kmh^{-1} . As he approaches a circular turn on the road of radius 30 m, he applies brakes and reduces his speed at the constant rate 0.5 ms^{-2} . What is the magnitude and direction of the net acceleration of the cyclist on the circular turn?

ANSWERS

$$19. \quad w = \frac{88}{25} \text{ rad s}^{-1} \quad w = \frac{2\pi}{T} = \frac{2\pi N}{t}$$
$$a = 991.2 \text{ cms}^{-2}$$

$$20. \quad a_c = \frac{v^2}{r} = 0.7 \text{ ms}^{-2}$$

$$a_T = 0.5 \text{ ms}^{-2}$$

$$a = \sqrt{a_c^2 + a_T^2} = 0.86 \text{ ms}^{-2}$$

If θ is the angle between the net acceleration and the velocity of the cyclist, then

$$\theta = \tan^{-1} \frac{a_c}{a_T} = \tan^{-1}(1.4) = 54^\circ 28'$$

NUMERICAL

21. If the magnitude of two vectors are 3 and 4 and their scalar product is 6, find angle between them.
22. Find the value of λ so that the vector $\vec{A} = 2\hat{i} + \lambda\hat{j} + \hat{k}$ and $\vec{B} = 4\hat{i} - 2\hat{j} - 2\hat{k}$ are perpendicular to each other.
23. If \hat{i} and \hat{j} are unit vectors along X and y-axis respectively, then what is the magnitude and direction of $\hat{i} + \hat{j}$ and $\hat{i} - \hat{j}$.

ANSWERS

$$21. \quad \vec{A} \cdot \vec{B} = AB \cos \theta$$
$$\text{or } 6 = (3 \times 4) \cos \theta$$
$$\text{or } \theta = 60^\circ$$

$$22. \quad \because \vec{A} \perp \vec{B} \Rightarrow \vec{A} \cdot \vec{B} = 0$$
$$\Rightarrow \lambda = 3$$

UNIT – III

NEWTON LAW OF MOTION AND FRICTION

KEY CONCEPTS

- According to the **principle of conservation of linear momentum**, the vector sum of linear momenta of all the bodies in an isolated system is conserved.

Flight of rockets, jet planes, recoiling of a gun etc. are explained on the basis of this principle.

- Apparent weight of a man in an elevator is given by $W' = m(g \pm a)$.

where mg = real weight of the man. Acceleration = $(+a)$, when the lift is accelerating upwards and

Acceleration = $(-a)$ when the lift is accelerating downwards.

when lift is *moving* in uniform motion then $a = 0$, $w' = mg$ = real weight.

in free fall, $a = g \therefore W' = m(g - g) = 0$

i.e. apparent weight becomes zero.

- When two bodies of masses m_1 and m_2 are tied at the ends of an inextensible string passing over a light frictionless pulley, **acceleration** of the system is given by

$$a = \frac{(m_1 - m_2)g}{(m_1 + m_2)} \text{ and}$$

$$\text{Tension in the string is } T = \frac{2m_1m_2g}{(m_1 + m_2)}$$

- Impulse is defined as change in momentum.

Impulse $\vec{I} = \vec{F}_{av} \times t = \vec{p}_2 - \vec{p}_1$

where t is the time for which average force acts, $(\vec{p}_2 - \vec{p}_1)$ is change in linear momentum of the body.

- Any system is said to be in equilibrium if net force applied on the system is zero. In this case system is either at rest or in uniform motion.
- **Friction** is the opposing force that comes into play when one body is actually moving over the surface of another body or one body is trying to move over the surface of the other.

Two causes of friction are : roughness of surfaces in contact; (ancient view)

Force of adhesion between the molecules of the surfaces in contact. (Modern view)

- Type of solid friction :-
 1. Static friction. It comes in to effect when object is at rest but external force is applied.
 2. Dynamic friction- it comes in to effect when object is in motion.
 3. Rolling friction- it comes in to when object is in rolling.
- Limiting friction is the maximum value of static friction. Dynamic/Kinetic friction is somewhat less than the force of limiting friction.
- **Coefficient of friction** $\mu = F/R$
when F = external force and R = normal reaction
- **Angle of friction** (θ) is the angle which resultant of F and R makes with the direction of R. The relation between μ and θ is $\mu = \tan \theta$
- **Angle of Repose** (α) is the minimum angle of inclination of a plane with the horizontal, such that a body placed on hte plane just begins to slide down. $\mu = \tan \alpha$
- **Centripetal force** is the force required to move a body uniformly in a circle.

- **During motion on level curved road**, the necessary centripetal force is provided by the force of friction between the tyres and the road. The maximum velocity with which a vehicle can go round a level curve without skidding is $v = \sqrt{\mu r g}$.
- To increase speed on turn, **curved roads are usually banked** *i.e.* outer edge of the curved road is raised suitably above the inner edge. If θ is the angle of banking, then

$$\tan \theta = \frac{v^2}{r g}$$

When frictional force is ignored, the optimum speed is $v_0 = (r g \tan \theta)^{1/2}$

- While rounding a banked curved road, maximum permissible speed is given by $v_{\max} = \left[\frac{r g (\mu_s + \tan \theta)}{(1 - \mu_s \tan \theta)} \right]^{1/2}$ when friction is taken in to account.
- When a cyclist takes a turn. He bends a little inwards from his vertical position, while turning. Angle θ of bending from vertical position is given by

$$\tan \theta = \frac{v^2}{r g}$$

- **Motion along a vertical circle is a non uniform circular motion.** Tension in the string at any position is $T = \frac{m v^2}{r} + m g \cos \theta$, where θ is the angle of string with vertical line for looping with optimum speed :- (when tension at highest point is zero)

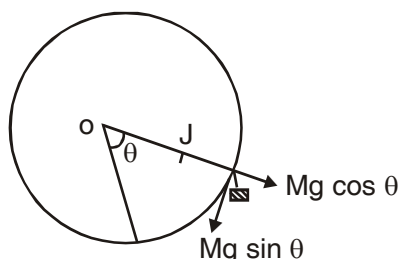

- (i) velocity of projection at lowest point L is $v_L \geq \sqrt{5 g r}$
- (ii) velocity at the highest point H is $v_H \geq \sqrt{gr}$
- (iii) Tension at lowest point $T_L \geq 6 mg$
- (iv) For oscillation in vertical circle $0 < v_L \leq \sqrt{2 g r}$
- (v) For leaving the vertical circle somewhere between $90^\circ < \theta < 180^\circ$, $\sqrt{2gr} < v_L < \sqrt{5 g r}$

- **Acceleration** of a body down a rough inclined plane $a = g(\sin\theta - \mu \cos\theta)$
- When a person of mass m climbs up a rope with acceleration a , the tension in the rope is $T = m(g + a)$

When the person climbs down the rope with acceleration a , tension in the rope is $T = m(g - a)$

- When a body slides down a smooth inclined plane of inclination θ with the horizontal, its acceleration down the plane is $a = g \sin\theta$
- Suppose two masses m_1 and m_2 are suspended vertically from a rigid support, with the help of strings as shown in Fig. when mass m_2 is pulled down with a force F , then

$$T_2 = F + m_2 g$$

and $T_1 = F + (m_1 + m_2) g$

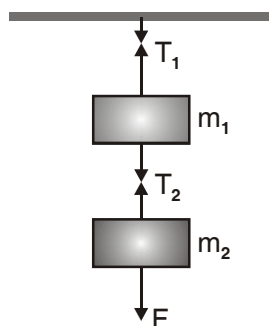

- When the same system of two masses attached to a string passes over a frictionless pulley at the edge of an inclined plane, as shown in Fig. equation will be...

$$m_1 a = T - m_1 g \sin \theta$$

$$m_2 a = m_2 g - T$$

$$R = m_1 g \cos \theta$$

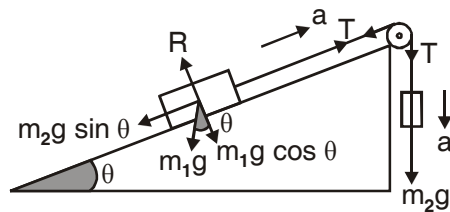

● **Three bodies in contact on a smooth horizontal table**

The action and reaction forces are as shown in Fig.

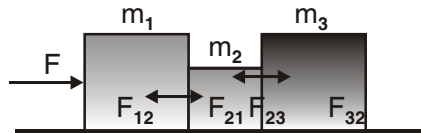

Common acceleration, $a = \frac{F}{m_1 + m_2 + m_3}$

Equation of motion of first body is

$$F - F_{12} = m_1 a \quad F_{12} = F_{21} = F_1$$

Equation of motion of 2nd body is

$$F_{21} - F_{23} = m_2 a \quad F_{23} = F_{32} = F_2$$

Equation of motion of 3rd body is

$$F_{32} = m_3 a$$

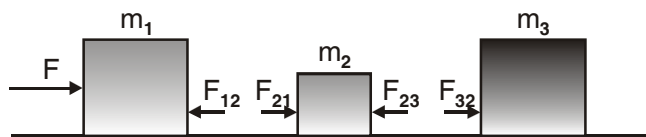

we get

$$F_1 = \frac{(m_2 + m_3) F}{m_1 + m_2 + m_3}$$

$$F_2 = \frac{m_3 F}{m_1 + m_2 + m_3}$$

- The minimum height through which a motor cyclist has to descend to a vertical loop of radius r is $h = \frac{5}{2}r$

- **Circular Motion**

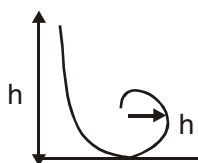

- **Angular displacement (θ)** : The angular displacement of an object moving around a circular path is defined as the angle subtended by the radius vector at the centre of the circular path in the given time.
- **Angular velocity (ω)** : It is defined as the time rate of change of angular displacement of the object *i.e.* $\omega = d\theta/dt$. Its S.I unit is rad/s.
- **Uniform circular motion** : When a point object is moving on a circular path with a constant speed, then the motion of the object is said to be a uniform circular motion.

- **Centripetal acceleration** : It is defined as the acceleration of an object undergoing uniform circular motion. It always acts along the radius towards the centre of the circular path. The magnitude of centripetal acceleration

$$\text{is, } a = \frac{v^2}{r} = r\omega^2 = 4\pi^2 r\nu^2 = \frac{4\pi^2 r}{T^2}$$

- The rate of change of angular velocity (ω) is called its angular acceleration (α) *i.e.*

$$\alpha = \frac{d\omega}{dt} = \frac{d^2\theta}{dt^2}$$

- The acceleration which changes the magnitude of the velocity is called tangential acceleration. It is given by $a_T = r\alpha$, where α is the angular acceleration.

The direction of tangential acceleration is along the tangent to curved path.

- When a body moves in a circular path with increasing angular velocity, it has two linear accelerations.

(i) centripetal acceleration, $a_c = v^2/r$; (ii) tangential acceleration, $a_T = r \alpha$;

Resultant acceleration of the body is

$$a = \sqrt{a_c^2 + a_T^2} \quad \text{and} \quad \tan \beta = \frac{a_T}{a_c}$$

where β is the angle between a and a_c

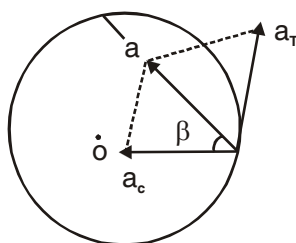

1 MARK QUESTIONS

1. A passenger sitting in a car at rest, pushes the car from within. The car doesn't move. Why?
2. Give the magnitude and directions of the net force acting on a rain drop falling with a constant speed.
3. Why the passengers in a moving car are thrown outwards when it suddenly takes a turn?
4. What is the purpose of using shockers in a car?
5. Why are tyres made of rubber not of steel?
6. Wheels are made circular. Why?
7. A force is required to keep a body in uniform motion in a straight line. Comments.
8. On a rainy day skidding takes place along a curved path. Why?
9. Why does a gun recoils when a bullet is being fired?

10. Why is it difficult to catch a cricket ball than a tennis ball even when both are moving with the same velocity?
11. Calculate the impulse necessary to stop a 1500 kg car moving at a speed of 25ms^{-1} . ($-37500\text{ N}\cdot\text{s}$)
12. Lubricants are used between the two parts of a machine. Why?
13. What provides the centripetal force to a car taking a turn on a level road?
14. What is inertial frame of reference?
15. An athlete runs a certain distance before taking a long jump. Why?
16. Action and reaction forces do not balance each other. Why?
17. The wheels of vehicles are provided with mudguards. Why?
18. China wares are wrapped in straw paper before packing?
20. Why is it difficult to walk on a sand?
21. The outer edge of a curved road is generally raised over the inner edge. Why?
22. Explain why the water doesn't fall even at the top of the circle when the bucket full of water is upside down rotating in a vertical circle?
23. Why does a speedy motor cyclist bends towards the centre of a circular path while taking a turn on it?
24. If the net force acting upon the particle is zero show that its linear momentum remains constant?

2 MARKS QUESTIONS

1. A man getting out of a moving bus runs in the same direction for a certain distance. Comment.
2. The motion of a particle of mass m is described by $h = ut + \frac{1}{2}gt^2$. Find the force acting on particle. ($F = mg$)
3. It is difficult to push a box full of clothes than an empty box. Explain.
4. A particle of mass 0.3 kg is subjected to a force of $F = -kx$ with $k = 15\text{ Nm}^{-1}$. What will be its initial acceleration if it is released from a point 20 cm away from the origin? ($a = -10\text{ ms}^{-2}$)

5. A 50 g bullet is fired from a 10 kg gun with a speed of 500 ms^{-1} . What is the speed of the recoil of the gun. (2.5 ms^{-1})
6. A block of mass M is pulled along a horizontal frictionless surface by a rope of mass m by applying a force P at the free end of the rope. Find the force exerted by the rope on the block. $F = M \left(\frac{P}{M + m} \right)$
7. Three forces F_1 , F_2 and F_3 are acting on the particle of mass m which is stationary. F_2 is perpendicular to F_1 if F_1 is removed, what will be the acceleration of particle? $(a = F_1/m)$
8. A spring balance is attached to the ceiling of a lift. When the lift is at rest spring balance reads 49 N of a body hang on it. If the lift moves :-
- (i) Downward
 - (ii) upward, with an acceleration of 5 ms^{-2}
 - (iii) with a constant velocity.

What will be the reading of the balance in each case?

$(24\text{N}, 74 \text{ N}, 49\text{N})$

9. It is easier to pull a roller than to push it. Why?
10. A horse cannot pull a cart and run in empty space. Why?
11. A bob of mass 0.1 kg hung from the ceiling of room by a string 2 m long is oscillating. At its mean position the speed of the bob is 1 ms^{-1} . What is the trajectory of the oscillating bob if the string is cut when the bob is :-
- (i) At the mean position (Parabolic)
 - (ii) At its extreme position. $(\text{vertically downwards})$
13. Define force of friction? How does ball bearing reduce friction?
14. Is larger surface area brake on a bicycle wheel more effective than smaller surface area brake? Explain?

3 MARKS QUESTIONS

1. A block of mass 500g is at rest on a horizontal table. What steady force is required to give the block a velocity of 200 cms^{-1} in 4 s ?

2. A force of 98 N is just required to move a mass of 45 kg on a rough horizontal surface. Find the coefficient of friction and angle of friction?
(0.22, $12^\circ 24'$)
3. Calculate the force required to move a train of 200 quintal up on an incline plane of 1 in 50 with an acceleration of 2 ms^{-2} . The force of friction per quintal is 0.5 N.
(40200N)
4. An aeroplane requires to take off a speed of 80 km h^{-1} on a runway of 100m. Mass of the plane is 10000 kg and coefficient of friction between the plane and the ground is 0.2. If the acceleration of the plane is uniform during take off, Calculate the minimum force required by the engine for the take off.
(27.13 N)
5. A smooth block is released from rest on a 30° incline and travels a distance d . If the time taken to slide on a rough 30° inclined surface is n times large to cover the same distance on a smooth incline. Find the coefficient of friction?
 $\left(\frac{1}{\sqrt{3}} \left(1 - \frac{1}{n^2} \right) \right)$

6. What is the acceleration of the block and trolley system as in fig., if the coefficient of kinetic friction between the trolley and the surface is 0.04? Also calculate tension in the string. Take $g = 10 \text{ ms}^{-2}$, mass of string is negligible.
(0.957 ms^{-2} , 27.13 N)

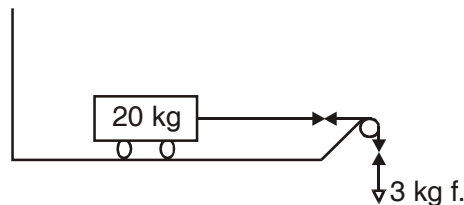

7. Three blocks of masses $m_1 = 10 \text{ kg}$, $m_2 = 20 \text{ kg}$ and $m_3 = 30 \text{ kg}$ are connected by strings on smooth horizontal surface and pulled by a force of 60 N. Find the acceleration of the system and tensions in the string.

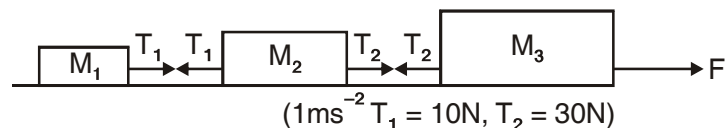

8. Three masses $m_1 = 2 \text{ kg}$, $m_2 = 3 \text{ kg}$ and $m_3 = 5 \text{ kg}$ are suspended with a string which is passed over a pulley as shown in fig. Calculate T_1 , T_2 , T_3 when the system is :-

- (i) Stationary
- (ii) Moving upward with an acceleration of 2ms^{-2} .

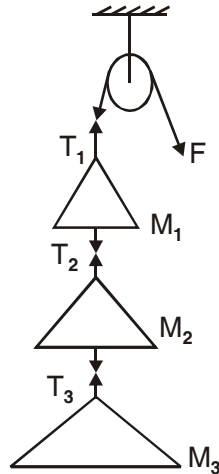

- (i) (98 N, 78.4 N, 49 N)
- (ii) (118 N, 94.4N, 59 N)

9. A mass of 6 kg is suspended by a rope of length 2 m from the ceiling. A force of 50 N horizontally is applied at the mid – point. P of the rope. Calculate the angle of rope makes with the vertical. Neglect the mass of rope. ($g = 9.8 \text{ ms}^{-2}$) ($\theta = 40^\circ$)

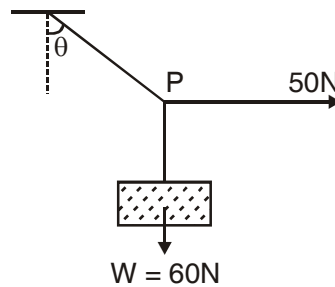

10. A circular race track of radius 300 m is banked at an angle of 15° . If the coefficient of friction between the wheels of a race car and the road is 0.2, what is :-
- (i) The optimum speed of the race car to avoid wear and tear of the tyres and
 - (ii) Maximum permissible speed to avoid slipping?
(28.2 ms^{-1} , 38.2 ms^{-1})

11. A bullet of mass 0.01 kg is fired horizontally into a 4 kg wooden block at rest on a horizontal surface. The coefficient of kinetic friction between the block and surface is 0.25. The bullet remain embedded in the block and combination moves 20 m before coming to rest. Find the speed of the bullet strike the block? (4000 m/s)
12. A glass marble of mass 300 g after falling from a height of 40 m rebounds to a height of 10 m. Find the impulse and the average force between the marble and the floor. The time during which they are in contact is 0.1 s. Take $g = 9.8 \text{ ms}^{-2}$. (4.2N ; 42N)

5 MARKS QUESTIONS

13. Define the principle of conservation of linear momentum. Deduce the law of conservation of linear momentum from Newton's third law of motion.
14. Why circular roads are banked? Derive an expression for angle of banking for safe circular turn?
15. Obtain an expression for minimum velocity of projection of a body at the lowest point for Looping a vertical loop.
16. Show that the area under the force-time graph gives the magnitude of the impulse of the given force for the following case when (i) force is constant (ii) variable force.
17. Derive an expression for acceleration of a body down a rough inclined plane? (Sliding only)

UNIT – IV

WORK ENERGY AND POWER

- Work done (W) by a constant force \vec{F} in producing a displacement \vec{s} in a body is

$$W = \vec{F} \cdot \vec{s} = Fs \cos \theta, \text{ where } \theta \text{ is smaller angle between } \vec{F} \text{ and } \vec{s}.$$

- If the force is not constant,

$$W = \int \vec{F} \cdot d\vec{s} = \text{area under the force displacement graph.}$$

- Work done is a *scalar* quantity.
- Work done = *Positive* when θ lies between 0 and $\pi/2$. Work done = *negative* when θ lies between $\frac{\pi}{2}$ and π . Work done = zero, when $\theta = \frac{\pi}{2}$
- SI unit of work is *joule* and the cgs unit of work is *erg*.

| S.No. | Unit | Symbol | Equivalent in joule |
|-------|---------------|--------|-------------------------|
| 1. | erg | erg | 10^{-7} J |
| 2. | Calorie | Cal. | 4.2 J |
| 3. | Kiowatt hour | k Wh | 3.6×10^6 J |
| 4. | electron volt | e V | 1.6×10^{-19} J |

- **In a conservative force**, work done is independent of the path followed by the body.
- **Work done by a spring force**

$$W = -\frac{1}{2} k x^2$$

where k is spring constant and x is the displacement from normal position of rest.

- Power of a body is defined as the *time rate of doing work* by the body.

$$P = \frac{dw}{dt} = \frac{\vec{F} \cdot d\vec{s}}{dt} = \vec{F} \cdot \vec{v} \quad \left(\because \vec{v} = \frac{d\vec{s}}{dt} \right)$$

Thus, $P = \vec{F} \cdot \vec{v} = F v \cos \theta$

Here, θ is angle between \vec{F} and \vec{v} of the body.

The practical unit of power is horse power (*h.p.*), where $1 \text{ h.p.} = 746 \text{ W}$

- **Energy** of a body is defined as the *capacity of the body* to do the work. Energy is a *scalar* quantity. Energy has the same units and dimensions as those of work.
- “*Principle of conservation of energy*”, according to which sum of total energy in this universe remains constant. The amount of energy disappearing in one form is exactly equal to the amount of energy appearing in any other form.
- **Kinetic Energy** of a body is the energy possessed by the body due to its motion.

K.E. of translation = $\frac{1}{2} m v^2$ where m is mass and v is velocity of the body.

- The energy stored in a body or system due to its configuration or shape is called *potential energy*.

Gravitational P.E. = mgh

where m is mass of a body at a height h and acceleration due to gravity is g .

P.E. may be positive or negative when forces involved are repulsive, P.E. is positive

When forces involved are attractive, P.E. is negative.

- **Mechanical Energy**

Mechanical energy of a particle or system is defined as the sum of K.E. and P.E. of the system. K.E. is always positive, but The mechanical energy may be zero.

Positive or negative. Negative mechanical energy represents a *bound state*.

- According to **work energy theorem**, work and energy are equivalent. Work done by a force on a body results in the net increase in K.E. of the body by the same amount.
- The equivalence between mass and energy is expressed in terms of *Einstein relation*.

$$E = mc^2$$

Where m is the **change in mass** and E is the energy and c is velocity of light in vaccum.

- **Conservative and Non-conservative Forces**

| S.No. | Conservative forces | Non Conservative forces |
|-------|--|---|
| 1. | Work done by such forces in displacing a particle does not depend upon the path along which particle is displaced. | 1. Work done by such forces in displacing a particle depends upon the path along which particle is displaced. |
| 2. | Work done by such forces in displacing a particle around a closed path is zero. | 2. Work done by such forces in displacing a particle around a closed path is NOT zero. |
| 3. | K.E. of particle remains constant. | 3. K.E. of particle changes. |

- **Collisions**

When a body strikes against body or one body influences the other from a distance, **collision is said to be occur**. Collisions are of two types :

- Perfectly elastic collision* - in which there is *no change in kinetic energy of the system*, i.e., total K.E. before collision = total K.E. after collision.
- Perfectly inelastic collision* - in which *K.E. is NOT conserved*. the bodies stick together after impact.

- If the initial and final velocities of colliding bodies lie along the same line then it is known as head on collision.



law of conservation of linear momentum. $m_1u_1 + m_2u_2 = m_1v_1 + m_2v_2$

principle of conservation of K.E.

$$\frac{1}{2} m_1 u_1^2 + \frac{1}{2} m_2 u_2^2 = \frac{1}{2} m_1 v_1^2 + \frac{1}{2} m_2 v_2^2$$

$$v_1 = \frac{(m_1 - m_2)}{m_1 + m_2} u_1 + \frac{2m_2 u_2}{m_1 + m_2} \text{ and } v_2 = \frac{2m_1 u_1}{m_1 + m_2} + \frac{(m_2 - m_1)}{m_1 + m_2} u_2$$

- coefficient of restitution or resilience of the two bodies. $e = -\frac{v_1 - v_2}{u_1 - u_2}$

For a perfectly elastic collision, $e = 1$ and for a *perfectly inelastic collision*, $e = 0$. ($0 \leq e \leq 1$)

| ● S.N. | Perfectly elastic collisions | Perfectly Inelastic collisions |
|--------|--|---|
| 1. | Particles do not stick together after collision. | 1. Particles stick together after collision. |
| 2. | Rel. vel. of separation after collision = rel. vel. of approach before collision | 2. Rel. vel. of separation after collision in zero. |
| 3. | Coeff. of restitution, $e = 1$. | 3. Coeff. of restitution, $e = 0$ |
| 4. | Linear momentum is conserved. | 4. Linear momentum is conserved. |
| 5. | K.E. is conserved. | 5. K.E. is <i>not</i> conserved. |

For Competition

- Work done by a body *does not depend upon the time taken* to complete the work.
- When one end of a spring is attached to a fixed vertical support and a block attached to the free end moves on a horizontal table from $x = x_1$ to $x = x_2$, then

$$W = \frac{-1}{2} k (x_2^2 - x_1^2)$$

- Some practical units of energy and their relation with SI unit of energy (joule) are :
 - 1 calorie = 4.2 J
 - 1 kilowatt hour (kWh) = 3.6×10^6 J.
 - 1 electron volt (1 eV) = 1.6×10^{-19} J.

- Suppose a body dropped from a height h_0 above the ground strikes the ground with a velocity v_0 . If body rebound with a velocity v_1 and go to a height h_1 , then coefficient of restitution

$$e = \frac{v_1}{v_0} = \sqrt{\frac{2g h_1}{2g h_0}} = \left(\frac{h_1}{h_0}\right)^{1/2}$$

If v_n is velocity with which the body rebounds after n collisions to a height

$$h_n, \text{ then } \frac{v_n}{v_0} = \left(\frac{h_n}{h_0}\right)^{1/2} = e^n$$

- When a machine gun of power P fires n bullets per second, each with K.E. = E , then $P = n E$.
- Thus power dissipated by the centripetal force is zero.
- Work done against friction on a horizontal surface is
 $W = \mu R x = \mu m g x$
- Work done against friction while moving up an inclined plane is $W = F x = \mu R x = (\mu m g \cos \theta) x$
- Stopping distance of a vehicle = K.E./stopping force.
- When two vehicles of masses m_1, m_2 moving with velocities v_1 and v_2 respectively are stopped by the same force, their stopping distances x_1

$$\text{and } x_2 \text{ are } \frac{x_1}{x_2} = \frac{\text{K.E.}_1}{\text{K.E.}_2} = \frac{\left(\frac{1}{2}\right) m_1 v_1^2}{\left(\frac{1}{2}\right) m_2 v_2^2}$$

The stopping times t_1 and t_2 of the two vehicles are $\frac{t_1}{t_2} = \frac{p_1}{p_2} = \frac{m_1 v_1}{m_2 v_2}$

- When linear momentum of a body increases by a factor n , its kinetic energy is increased by a factor n^2
- When speed of a vehicle becomes n times, its stopping distance becomes n^2 times, provided stopping force applied is **remains same**.

- When the collision is not perfectly elastic, then the expressions for velocities after direct **collision** are :

$$v_1 = \frac{(m_1 - em_2)u_1}{m_1 + m_2} + \frac{(1 + e)m_2u_2}{m_1 + m_2}; v_2 = \frac{(1 + e)m_1u_1}{m_1 + m_2} + \frac{(m_2 - em_1)u_2}{m_1 + m_2}$$

- **Graphs between p and E.**

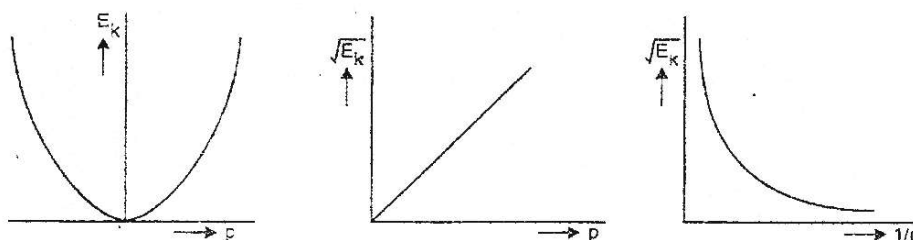

- **Spring:-**

- Spring constant $k = F/x =$ restoring force per unit extension/compression.
- If a spring of spring constant k is cut into n parts of equal length, spring constant of each part = nk .
- When a spring of spring constant k is cut into two parts of unequal lengths l_1 and l_2 , the spring constants of the two parts are :

$$k_1 = \frac{k(l_1 + l_2)}{l_1} \text{ and } k_2 = \frac{k(l_1 + l_2)}{l_2}$$

- When two springs of spring constants k_1 and k_2 are joined *in series*.

the equivalent spring constant k of the combination is given by

$$\frac{1}{k} = \frac{1}{k_1} + \frac{1}{k_2}$$

- When two springs of spring constants k_1 and k_2 are connected in parallel the equivalent spring constant k is given by $k = k_1 + k_2$

WORK ENERGY AND POWER

VERY SHORT ANSWER QUESTION (MARK 1)

1. Define the conservative and non conservative forces. Give examples of each.
2. A light body and a heavy body have same linear momentum. Which one has greater K.E? (Ans. : lighter body has more K.E.)
3. The momentum of the body is doubled what % does its K.E change? (300%)
4. How can we change the momentum of a body without change in its K.E.?
5. Which spring has greater value of spring constant – a hard spring or a delicate spring?
6. Two bodies stick together after collision. What type of collision is in b/w these two bodies?
7. State the two conditions under which a force does no work?
8. How will the momentum of a body changes if its K.E is doubled?
9. K.E of a body is increased by 300 %. Find the % increase in its momentum? (100%)
10. A light and a heavy body have same K.E. which of the two have more momentum and why? (heavier body)
11. Mountain roads rarely go straight up the slop, but wind up gradually. Why?
12. A truck and a car moving with the same K.E on a straight road. Their engines are simultaneously switched off which one will stop at a lesser distance?
13. What happens to the P.E of a bubble when it rises in water? (decrease)
14. A body is moving at constant speed over a friction surface. What is the work done by the weight of the body? ($W = 0$)
15. What type of energy is stored in the spring of a water?
16. Define spring constant of a spring?

17. What happens when a sphere collides head on elastically with a sphere of same mass initially at rest?

SHORT ANSWER QUESTION (2 MARKS)

1. A elastic spring is compressed by an amount x . Show that its P.E is $\frac{1}{2}kx^2$ Where k is the spring constant?
2. Derive an expression for its K.E of a body of mass m moving with a velocity v by calculus method.
3. Show that the total mechanical energy of a body falling freely under gravity is conserved.
4. How high must a body be lifted to gain an amount of P.E equal to the K.E it has when moving at speed 20 ms^{-1} . (The value of acceleration due to gravity at a place is 9.8 ms^{-2}). (20.2 m)
5. Calculate the work done in moving the object from $x = 2$ to $x = 3$ m from the graph given :-

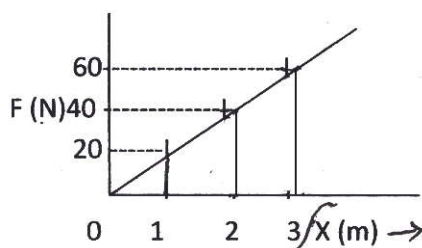

6. After bullet is fired, gun recoils freely. Compare the K.E. of bullet and the gun. ($KE_b > KE_g$)
7. A bob is pulled sideway so that string becomes parallel to horizontal and released. Length of the pendulum is 2 m. If due to air resistance loss of energy is 10% what is the speed with which the bob arrived at the lowest point.
8. Two springs A and B are identical except that A is harder than B ($K_A > K_B$) if these are stretched by the equal force. In which spring will more work be done?
9. Explain the term work? show that work done is equal to the dot product of force and displacement.

10. Find the work done if a particle moves from position $\vec{r}_1 = (3\hat{i} + 2\hat{j} - 6\hat{k})$ to a position $\vec{r}_2 = (14\hat{i} + 13\hat{j} - 9\hat{k})$ under the effect of force, $\vec{F} = (4\hat{i} + \hat{j} + 3\hat{k})\text{N}$.
11. A particle of mass 1 g moving with a velocity $\vec{v}_1 = (3\hat{i} - 2\hat{j})$ has elastic collision with another particle of mass 2 g moving with a velocity $\vec{v}_2 = 4\hat{j} - 6\hat{k}$. Find the velocity of the particle formed. ($V = 4.6 \text{ ms}^{-1}$)
12. A body of mass m accelerate uniformly from rest to velocity v_1 , in time t_1 . Derive an expression for the instantaneous power delivered to the body as a function of time
($P = mv_1^2/t_1^2$)
13. How much energy is related when 1 mg of U is completely destroyed in an atomic bomb?
(9×10^{10})J
14. 20 J work is required to stretch a spring through 0.1 m. Find the force constant of the spring. If the spring is further stretched through 0.1m. Calculate work done.
(4000 Nm^{-1} , 60 J)
15. For a particle executing S.H.M, potential energy function is given by $V(x) = 1/2 kx^2$, $K = 0.5 \text{ Nm}^{-1}$ is force constant of the oscillator. If the total energy of the particle is 1 J, show that particle turn back when $x = \pm 2\text{m}$ from its mean position.
16. A pump on the ground floor of a building can pump up water to fill a tank of volume 30m^3 in 15 min. If the tank is 40 m above the ground, how much electric power is consumed by the pump. The efficiency of the pump is 30%.
(43.567 Kw)
17. A force $\vec{F} = 2x\hat{j}\text{N}$ acts in a region, where a particle moves clock wise along the sides of a square of length 2m. Find the total amount of work done?
(8 J)
18. A mass less pan is placed on an elastic spring. Spring is compressed by 0.01 m when a sand bag of mass 0.1 kg is dropped on it from a height 0.24 m. From what height should the sand bag be dropped to cause a compression of 0.04 m?
(3.96 m)
19. State and prove Work Energy Theorem.

20. Show that in an elastic one dimensional collision the relative velocity of approach before collision is equal to the relative velocity of separation after collision.
21. Show that in a head on collision between two balls of equal masses moving along a straight line the balls exchange their velocities.
22. A force acting on a body along Y axis the direction of motion of the body. If this force produces a potential energy $U = A x^4$ when $A = 1.2 \text{ Jm}^{-4}$. What is the force acting on the body when the body is at $x = 0.8\text{m}$. (2.46N)
23. A spring of force constant K is cut into two equal pieces. Calculate force constant of each part.
24. How vibration of a simple pendulum does illustrate the principle of energy conservation?
25. A spring is first stretched by x by applying a force F . Now the extension of the spring is increases to $3x$. What will be the new force required to keep the spring in this condition? Calculate the work done in increasing the extension.

LONG ANSWER QUESTIONS (5 MARKS)

26. Show that at any instant of time during the motion total mechanical energy of a freely falling body remains constant. Show graphically the variation of K.E. and P.E. during the motion.
27. Define spring constant, Write the characteristics of the force during the elongation of a spring. Derive the relation for the PE stored when it is elongated by X . Draw the graphs to show the variation of P.E. and force with elongation.
28. How does a perfectly inelastic collision differ from perfectly elastic collision? Two particles of mass m_1 and m_2 having velocities U_1 and U_2 respectively make a head on collision. Derive the relation for their final velocities. Discuss the following special cases.
 - (i) $m_1 = m_2$
 - (ii) $m_1 \gg m_2$ and $U_2 = 0$
 - (iii) $m_1 \ll m_2$ and $u_1 = 0$

29. A body is moving along z-axis of a coordinate system under the effect of a constant force $\vec{F} = (2\hat{i} + 3\hat{j} - \hat{k})$ N. Find the work done by the force in moving the body a distance of 2 m along z-axis.
30. In lifting a 10 kg weight to a height of 2m, 230 J energy is spent. Calculate the acceleration with which it was raised?
31. A bullet of mass 0.02 kg is moving with a speed of $10\text{m}^{-1}\text{s}$. It can penetrate 10 cm of a wooden block, and comes to rest. If the thickness of the target would be 6 cm only find the KE of the bullet when it comes out.
(Ans : 0.4 J)
32. A man pulls a lawn roller with a force of 20 kg F. If he applies the force at an angle of 60° with the ground. Calculate the power developed if he takes 1 min in doing so.
33. A ball bounces to 80% of its original height. Calculate the mechanical energy lost in each bounce.
34. A pendulum bob of mass 0.1 kg is suspended by a string of 1 m long. The bob is displaced so that the string becomes horizontal and released. Find its kinetic energy when the string makes an angle of (i) 0° , (ii) 30° with the vertical.
35. A particle of mass m is moving in a horizontal circle of radius r under a centripetal force equal to k/r^2 , k is a constant. What is the total energy of the particle.
($-k/2r$)
36. The K.E. of a particle moving along a circle of radius R depends on the distance covered S as $T = \alpha S^2$ where α is constant. Find the force acting on the particle as a function of S.
 $\left(F = 2\alpha S \sqrt{1 + s^2/R^2} \right)$
37. Derive the relation $E = \Delta mc^2$.

Solution: As $m = m_0 / \sqrt{1 - v^2/c^2}$ or $m(1 - v^2/c^2)^{1/2} = m_0$ or $m^2(1 - v^2/c^2) = m_0^2$

$$\text{or } m^2c^2 - m^2v^2 = m_0^2c^2$$

Differentiating both sides taking m_0 and c as constant

$$2m \, dm \, c^2 - 2m \, dm \, v^2 - m^2 \, 2v \, dv = 0 \text{ or } 2m(dm \, c^2 - dm \, v^2 - mv \, dv) = 0$$

But $2m \neq 0$ so, $dm c^2 - dm v^2 - m v dv = 0$ or $v^2 dm + m v dv = c^2 dm$ (1)

Let a force F applied on the body displaces it through a distance dx . The work done in doing so will change the KE of the body. $\Delta K.E. = dE = F \cdot dx$

But $F = d(mv)/dt = (mdv/dt + vdm/dt)$ or $dw = F \cdot dx$

$dw = (mdv/dt + vdm/dt)dx$ or $dw = mdv/dt \cdot dx + vdm/dt \cdot dx$

$dw = mdx/dt \cdot dv + vdx/dt \cdot dm$ $dw = dE = m v dv + v^2 dm$

from equ. (i) $dE = c^2 dm$ (2)

let the mass increases from m_0 to m as K.E. increases from 0 to E . Integrating eq. 2 for the given limits

$E - 0 = c^2(m - m_0)$ As $m_0 c^2$ rest mass energy = 0

therefore **$E = m c^2$**

38. Force acting on a particle varies with x as shown in figure, below. Calculate the work done by the force as the particle moves from $x = 0$ to $x = 6m$.

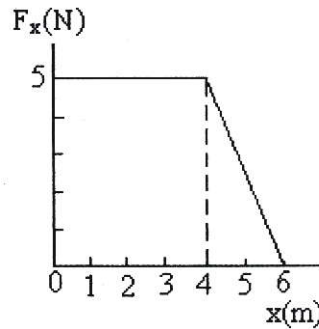

39. The mass system is kept on sphere. Ball 1 is slightly disturbed. What is the velocity of these balls when it is making angle θ with horizontal (friction is absent everywhere).

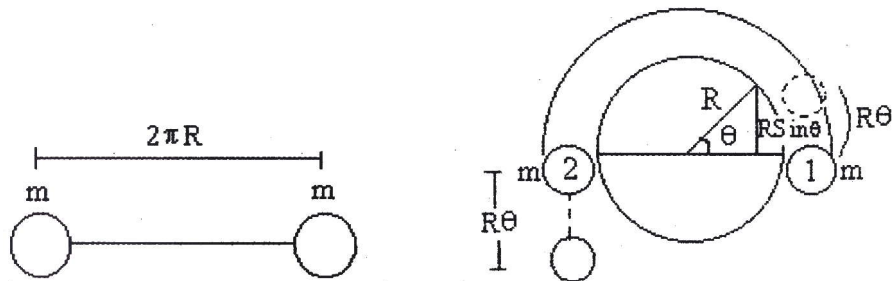

40. What is the minimum value of 'u' for completing circular motion of particle as shown in figure given below?

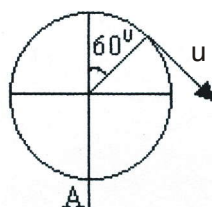

41. A block is projected horizontally on rough horizontal floor. The coefficient of friction between the block and the floor is μ . The block strikes a light spring of stiffness k with velocity v_0 . Find the maximum compression of the spring.

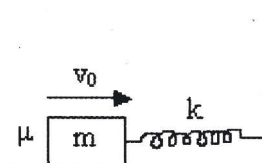

42. In figure a and b, AC, DE and EF are fixed inclined planes $BC = EF = x$ and $AB = DE = y$. A small block of mass m is released from rest from the point A. It slides down AC and reaches C with a speed V_C . The same block is released from rest from the point D, it slides down DEF and reaches the point F with speed V_F . The coefficient of kinetic friction between the block and the surface AC and DEF is μ , calculate V_C and V_F .

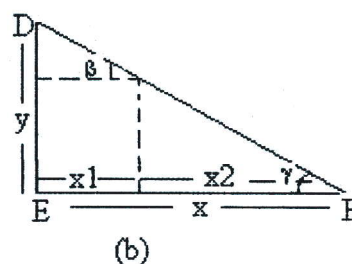
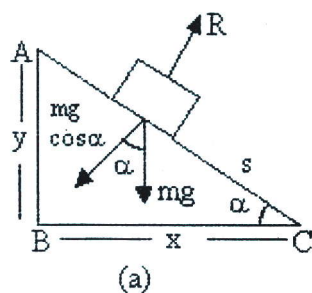

43. A locomotive of mass m starts moving so that its velocity v is according to the law $v = a\sqrt{s}$, where a is constant and s is distance covered. Find the total work done by all the forces acting the locomotive during the first t seconds after the beginning of motion.

44. The Kinetic energy of a particle moving along a circle of radius R depends on the distance covered S and $T = \alpha s^2$ where α is constant. Find the force acting on the particle as a function of S .
45. A ball suspended by a string of length 20 cm is fixed to the free end of the pivoted rod of length 40 cm as shown in the figure. The rod is made to rotate in a horizontal plane with constant angular speed. The string makes an angle $\theta = 30^\circ$ with the vertical axis. Find the angular speed of the rotation?

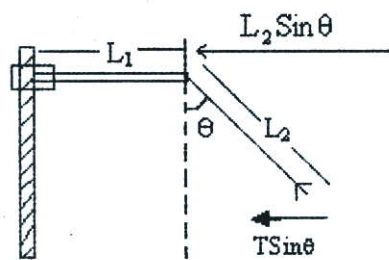

ω = angular speed; T = Tension in the string.

46. A smooth, light rod AB can rotate about a vertical axis passing through its end A . The rod is fitted with small sleeve of mass m attached to the end A by a weightless spring of length 10 , stiffness k . What work must be performed to slowly get this system going and the angular velocity w ?

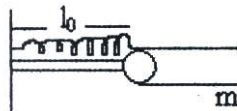

47. A spring gun having spring constant 100 N/m , a small ball of mass 0.1 Kg is placed in its barrel by compressing the spring through 0.05m as shown in figure.

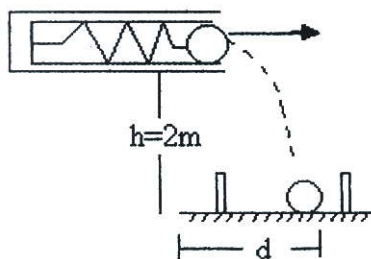

- (a) Find the velocity of the ball when spring is released.
- (b) Where should a box be placed on ground so that ball falls in it, if the ball leaves the gun horizontally at a height of 2m above the ground.
48. A turn of radius 20m is banked for the vehicle of mass 200kg going at a speed of 10ms^{-1} . Find the direction and magnitude of frictional force acting on a vehicle if it moves with a speed (a) 5 m/s (b) 15 m/s assume the friction is sufficient to prevent slipping ($g = 10\text{m/s}^2$).

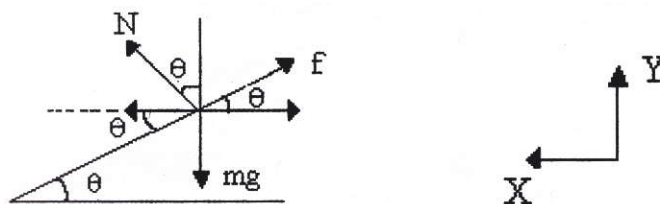

49. A block of mass m is pushed against a spring constant K fixed at one end to a wall. The block can slide on a frictionless table as shown in figure. The natural length of the spring is L_0 and it is compressed to half its natural length when the block is released. Find the velocity of the block as a function of its distance x from the wall.

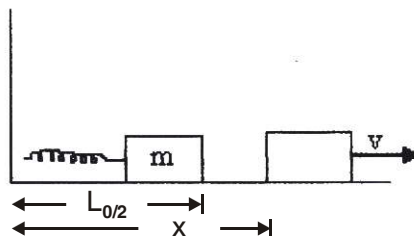

50. A ball falls under gravity from a height 10m, with an initial velocity V_0 , it hits the ground, loses 50% of its energy after collision and it rises to the same height. What is the value of V_0 ?
51. A block of mass M is pulled along a horizontal surface by applying a force at an angle θ with horizontal. Co-efficient of friction between block and surface is μ . If the block travels with uniform velocity, Find the work done by this applied force during a displacement d of the block.

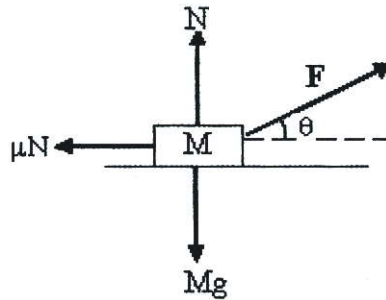

52. A block of mass m released from rest onto an ideal non-deformed spring of spring constant ' K ' from a negligible height. Neglecting the air resistance, find the compression ' d ' of the spring.

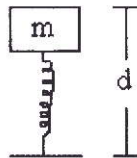

53. A particle slides down a smooth inclined plane of elevation θ , fixed in an elevator going up with an acceleration a_0 as shown in figure. The base of the incline has a length L . Find the time taken by the particle to reach the bottom.

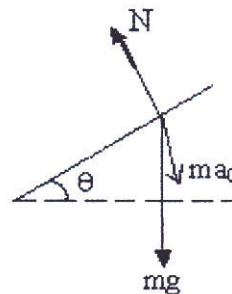
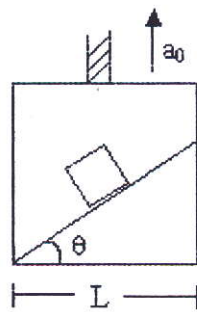

54. 6m long ladder weighting 30Kg rest with its upper end against a smooth wall and lower end on rough ground. What should be the minimum coefficient of friction between the ground and the ladder for it to be inclined at 60° with the horizontal without slipping? Take $g = 10\text{m/s}^2$.

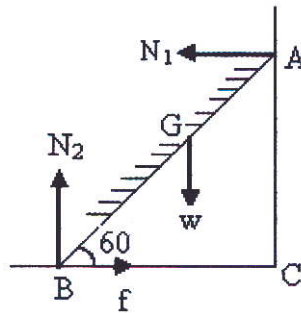

55. A block of mass 200kg is set into motion on a frictionless horizontal surface with the help of frictionless pulley and a rope system as shown in figure. What horizontal force F should be applied to produce in the block an acceleration of 1 m/s^2 ?

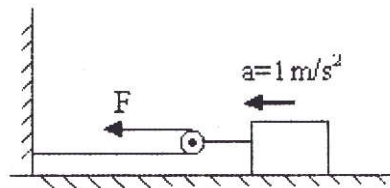

56. Two bodies of masses m_1 and m_2 are connected by a light string going over a smooth light pulley at the end of an incline. The mass m_1 lies on the incline and m_2 hangs vertically. The system is at rest; Find the angle of incline and the force exerted by the incline on the body of mass m_1 .

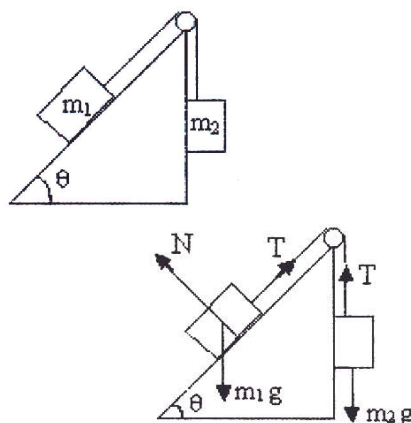

UNIT V

MOTION OF SYSTEMS OF PARTICLES AND RIGID BODY

- **Centre of mass** of a body is a point where the entire mass of the body can be supposed to be concentrated.
- For a system of n -particles, the centre of mass is given by

$$\vec{r} = \frac{m_1\vec{r}_1 + m_2\vec{r}_2 + m_3\vec{r}_3 + \dots + m_n\vec{r}_n}{m_1 + m_2 + m_3 + \dots + m_n} = \frac{\sum_{i=1}^{i=n} m_i\vec{r}_i}{M}$$

where $M = m_1 + m_2 + \dots + m_n$

- **Torque** ($\vec{\tau}$) *The turning effect of a force with respect to some axis, is called moment of force or torque due to the force.* Torque is measured as the product of the magnitude of the force and the perpendicular distance of the line of action of the force from the axis of rotation.

$$\vec{\tau} = \vec{r} \times \vec{F}$$

SI unit of torque is Nm.

- **Angular momentum** (\vec{L}). *It is the rotational analogue of linear momentum and is measured as the product of the linear momentum and the perpendicular distance of its line action from the axis of rotation.*

If \vec{P} is linear momentum of the particle and \vec{r} its position vector, then angular momentum of the particle, $\vec{L} = \vec{r} \times \vec{p}$

SI unit of angular momentum is $\text{kg m}^2 \text{s}^{-1}$.

- **Relation** between torque and angular momentum :

$$\vec{\tau} = \frac{d\vec{L}}{dt}$$

- **Law of conservation of angular momentum.** If no external torque acts on a system, then the total angular momentum of the system always remains conserved.

$$\vec{L}_1 + \vec{L}_2 + \vec{L}_3 + \dots + \vec{L}_n = \vec{L}_{total} = a \text{ constant}$$

- **Moment of inertia (I).** *The moment of inertia of a rigid body about a given axis is the sum of the products of masses of the various particles with squares of their respective perpendicular distances from the axis of rotation.*

$$I = m_1 r_1^2 + m_2 r_2^2 + m_3 r_3^2 + \dots + m_n r_n^2 = \sum_{i=1}^{i=n} m_i r_i^2$$

SI unit of moment of inertia is kg m².

- **Radius of gyration (K).** It is defined as the distance of a point from the axis of rotation at which, if whole mass of the body were concentrated, then

$$K = \sqrt{\frac{r_1^2 + r_2^2 + r_3^2 + \dots + r_n^2}{n}} \text{ and } I = MK^2.$$

SI unit of radius of gyration is m.

- **Theorem of perpendicular axes.** It states that the moment of inertia of a 2-d object about an axis perpendicular to its plane is equal to the sum of the moments of inertia of the lamina about any two mutually perpendicular axes in its plane and intersecting each other at the point, where the perpendicular axis passes through the **plane**.

$$I_z = I_x + I_y$$

where X and Y-axes lie in the plane of the **object** and Z-axis is perpendicular to its plane and passes through the point of intersection of X and Y axes.

- **Theorem of parallel axes.** It states that the moment of inertia of a rigid body about any axis is equal to moment of inertia of the body about a parallel axis through its centre of mass plus the product of mass of the body and the square of the perpendicular distance between the axes.

$I = I_c + M h^2$, where I_c is moment of inertia of the body about an axis through its centre of mass and h is the perpendicular distance between the two axes.

● **Moment of inertia of some object :-**

| S. No. | Body | Axis of rotation | Moment of Inertia (I) |
|--------|--|--|-----------------------|
| ● | Uniform circular ring of mass M and radius R | (i) about an axis passing through centre and perp. to its plane. | MR^2 |
| | | (ii) about a diameter. | $\frac{1}{2}MR^2$ |
| | | (iii) about a tangent in its own plane. | $\frac{3}{2}MR^2$ |
| | | (iv) about a tangent \perp to its plane. | $2 MR^2$ |
| ● | Uniform circular disc of mass M and radius R . | (i) about an axis passing through centre and perp. to its plane. | $\frac{1}{2}MR^2$ |
| | | (ii) about a diameter. | $\frac{1}{4}MR^2$ |
| | | (iii) about a tangent in its own plane. | $\frac{5}{4}MR^2$ |
| | | (iv) about a tangent \perp to its plane. | $\frac{3}{2}MR^2$ |
| ● | Solid sphere of radius R and mass M | (i) about its diameter. | $\frac{2}{5}MR^2$ |
| | | (ii) about a tangential axis. | $\frac{7}{5}MR^2$ |
| ● | Spherical shell of radius R and mass M . | (i) about its diameter. | $\frac{2}{3}MR^2$ |
| | | (ii) about a tangential axis. | $\frac{5}{3}MR^2$ |
| ● | Long thin rod of | (i) about an axis through | $\frac{ML^2}{12}$ |

length L .

C.G. and \perp to rod.

- (ii) about an axis through $\frac{ML^2}{3}$
one end and \perp to rod.

- **Law of conservation of angular momentum.** If no external torque acts on a system, the total angular momentum of the system remains unchanged.

$I\vec{\omega} = \text{constant vector}$ or $I_1\omega_1 = I_2\omega_2$, provided no external torque acts on the system.

- For **translational equilibrium** of a rigid body, $\vec{F} = \sum_i \vec{F}_i = 0$
- For **rotational equilibrium** of a rigid body, $\vec{\tau} = \sum_i \vec{\tau}_i = 0$
- **Analogy between various quantities describing linear motion and rotational motion.**

| S.No. | linear motion | S.No. | Rotation motion |
|-------|--|-------|---|
| ● | Distance/displacement (s) | 1. | Angle or angular displacement (θ) |
| ● | Linear velocity, $v = \frac{dx}{dt}$ | 2. | Angular velocity, $\omega = \frac{d\theta}{dt}$ |
| ● | Linear acceleration, $a = \frac{dv}{dt} = \frac{d^2r}{dt^2}$ | 3. | Angular acceleration, $\alpha = \frac{d\omega}{dt} = \frac{d^2\theta}{dt^2}$ |
| ● | Mass (m) | 4. | Moment of inertia (I) |
| ● | Linear momentum, $p = m v$ | 5. | Angular momentum, $L = I\omega$ |
| ● | Force, $F = m a$ | 6. | Torque, $\tau = I\alpha$ |
| ● | Also, force $F = \frac{dp}{dt}$ | 7. | Also, torque, $\tau = \frac{dL}{dt}$ |
| ● | Translational KE, $K_T = \frac{1}{2}mv^2$ | 8. | Rotational K.E., $K_R = \frac{1}{2}I\omega^2$ |
| ● | Work done, $W = F s$ | 9. | Work done, $W = \tau \theta$ |
| ● | Power, $P = F v$ | 10. | Power, $P = \tau \omega$ |
| ● | (Principle of conservation of linear momentum) | | (Principle of conservation of angular momentum). |

- Equations of translatory motion 11. Equations of rotational motion
 - (i) $v = u + at$ (ii) $s = ut + \frac{1}{2}at^2$ $\omega_2 = \omega_1 + \alpha t$
 - (iii) $v^2 - u^2 = 2 a s$, (ii) $\theta = \omega_1 t + \frac{1}{2}\alpha t^2$
 - (iii) $\omega_2^2 - \omega_1^2 = 2 \alpha \theta$
-

Motion of a body rolling without slipping on an inclined plane acceleration

$$a = \frac{mg \sin\theta}{m + I/r^2}$$

Kinetic energy of a rolling body is

$$E_K = \text{K.E of translation } (K_T) + \text{K.E. of rotation } (K_e)$$

$$E_K = \frac{1}{2}Mv^2 + \frac{1}{2}I\omega^2$$

ROTATIONAL MOTION (1 MARK)

1. What is a rigid body?
2. State the principle of moments of rotational equilibrium.
3. Is centre of mass of a body necessarily lie inside the body? Give any example
4. Can the couple acting on a rigid body produce translatory motion?
6. Which component of linear momentum does not contribute to angular momentum?
8. A system is in stable equilibrium. What can we say about its potential energy?
10. Is radius of gyration a constant quantity?
11. Two solid spheres of the same mass are made of metals of different densities. Which of them has a large moment of inertia about the diameter?
12. The moment of inertia of two rotating bodies A and B are I_A and I_B ($I_A > I_B$) and their angular momenta are equal. Which one has a greater kinetic energy?

13. A particle moves on a circular path with decreasing speed. What happens to its angular momentum?
14. What is the value of instantaneous speed of the point of contact during pure rolling?
15. Which physical quantity is conserved when a planet revolves around the sun?
16. What is the value of torque on the planet due to the gravitational force of sun?
17. If no external torque acts on a body, will its angular velocity be constant?
18. Why there are two propellers in a helicopter?
20. A child sits stationary at one end of a long trolley moving uniformly with speed V on a smooth horizontal floor. If the child gets up and runs about on the trolley in any manner, then what is the effect of the speed of the centre of mass of the (trolley + child) system?

ANSWERS

3. No. example ring
4. No. It can produce only rotatory motion.
6. Radial Component
7. No, because centripetal acceleration is not zero.
8. P.E. is minimum.
11. No, it changes with the position of axis of rotation.
12. Sphere of small density will have large moment of inertia.
13. $K = \frac{L^2}{2I} \Rightarrow K_B > K_A$
14. as $\vec{L} = \vec{r} \times m\vec{v}$ i : e magnitude \vec{L} decreases but direction remains constant.
15. zero
16. Angular momentum of planet.

17. zero.
18. No. $\omega \propto \frac{1}{I}$.
19. due to conservation of angular momentum
20. No change in speed of system as no external force is working.

ROTATIONAL MOTION (2 MARKS)

1. Show that in the absence of any external force, the velocity of the centre of mass remains constant.
2. State the factors on which the position of centre of mass of a rigid body depends.
3. What is the turning effect of force called for ? On what factors does it depend?
4. State the factors on which the moment of inertia of a body depends.
5. On what factors does radius of gyration of body depend?
6. Why do we prefer to use a wrench of longer arm?
7. Can a body be in equilibrium while in motion? If yes, give an example.
8. There is a stick half of which is wooden and half is of steel. (i) it is pivoted at the wooden end and a force is applied at the steel end at right angle to its length (ii) it is pivoted at the steel end and the same force is applied at the wooden end. In which case is the angular acceleration more and why?
9. If earth contracts to half its radius what would be the length of the day at equator?
10. An internal force can not change the state of motion of centre of mass of a body. How does the internal force of the brakes bring a vehicle to rest?
11. When does a rigid body said to be in equilibrium? State the necessary condition for a body to be in equilibrium.
12. How will you distinguish between a hard boiled egg and a raw egg by spinning it on a table top?

13. What are binary stars? Discuss their motion in respect of their centre of mass.
14. In which condition a body lying in gravitational field is in stable equilibrium?
15. Give the physical significance of moment of inertia.

ANSWERS

2. (i) Shape of body
(ii) mass distribution
3. Torque
Factors (i) Magnitude of force
(ii) Perpendicular distance of force vector from axis of rotation.
4. (i) Mass of body
(ii) Size and shape of body
(iii) Mass distribution w.r.t. axis of rotation
(iv) position and orientation of rotational axis
5. Mass distribution.
6. to increase torque.
7. Yes, if body has no linear and angular acceleration. Hence a body in uniform straight line motion will be in equilibrium.
8. I (first case) $>$ I (Second case)
 $\therefore \tau = I\alpha$
 $\Rightarrow \alpha$ (first case) $<$ α (second case)
9. $I_1 = \frac{2}{5}MR^2 \Rightarrow I_2 = \frac{2}{5}M\left(\frac{R}{2}\right)^2 \Rightarrow I_2 = \frac{I}{4}$
 $L = I_1\omega_1 = I_2\omega_2$

or
$$I \left(\frac{2\pi}{T_1} \right) = \frac{1}{4} I \left(\frac{2\pi}{T_2} \right)$$

or
$$T_2 = \frac{T_1}{4} = \frac{24}{4} = 6 \text{ hours}$$

10. In this case the force which bring the vehicle to rest is friction, and it is an external force.
11. For translation equilibrium

$$\sum \vec{F}_{gt} = 0$$

For rotational equilibrium

$$\sum \vec{\tau}_{ext} = 0$$

12. For same external torque, angular acceleration of raw egg will be small than that of Hard boiled egg
14. When vertical line through centre of gravity passes through the base of the body.
15. It plays the same role in rotatory motion as the mass does in translatory motion.

ROTATIONAL MOTION (3 MARKS)

1. Derive the three equation of rotational motion (i) $\omega = \omega_0 + \alpha t$

(ii) $\theta = \omega_0 t + \frac{1}{2} \alpha t^2$

(iii) $\omega^2 = \omega_0^2 + 2 \alpha \theta$

under constant angular acceleration. Here symbols have usual meaning.

2. Obtain an expression for the work done by a torque. Hence write the expression for power.
3. Prove that the rate of change of angular momentum of a system of particles about a reference point is equal to the net torque acting on the system.

4. Derive a relation between angular momentum, moment of inertia and angular velocity of a rigid body.
5. Show that moment of a couple does not depend on the point about which moment is calculated.
6. A disc rotating about its axis with angular speed ω_0 is placed lightly (without any linear push) on a perfectly frictionless table. The radius of the disc is R . What are the linear velocities of the points A, B and C on the disc shown in figure. Will the disc roll?

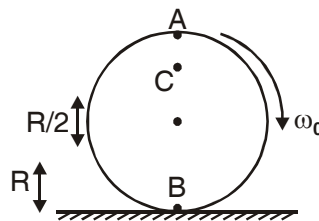

7. A uniform circular disc of radius R is rolling on a horizontal surface. Determine the tangential velocity (i) at the upper most point (ii) at the centre of mass and (iii) at the point of contact.
8. Derive an expression for the total work done on a rigid body executing both translational and rotational motions.
9. Prove that the acceleration of a solid cylinder rolling without slipping down an inclined plane is $\frac{2g}{3} \sin \theta$.
10. Show that the angular momentum of a particle is the product of its linear momentum and moment arm. Also show that the angular momentum is produced only by the angular component of linear momentum.

ANSWER

6. For A $V_A = R\omega_0$ in forward direction
 For B $V_B = R\omega_0$ in backward direction
 For C $V_C = \frac{R}{2}\omega_0$ in forward direction disc will not roll.

NUMERICALS

1. Three masses 3 kg, 4 kg and 5 kg are located at the corners of an equilateral triangle of side 1m. Locate the centre of mass of the system.
2. Two particles mass 100 g and 300 g at a given time have velocities $10\hat{i} - 7\hat{j} - 3\hat{k}$ and $7\hat{i} - 9\hat{j} + 6\hat{k}$ ms^{-1} respectively. Determine velocity of COM.
3. From a uniform disc of radius R, a circular disc of radius R/2 is cut out. The centre of the hole is at R/2 from the centre of original disc. Locate the centre of gravity of the resultant flat body.
4. The angular speed of a motor wheel is increased from 1200 rpm to 3120 rpm in 16 seconds. (i) What is its angular acceleration (assume the acceleration to be uniform) (ii) How many revolutions does the wheel make during this time?
5. A metre stick is balanced on a knife edge at its centre. When two coins, each of mass 5 g are put one on top of the other at the 12.0 cm mark, the stick is found to be balanced at 45.0 cm, what is the mass of the metre stick?
6. A 3m long ladder weighting 20 kg leans on a frictionless wall. Its feet rest on the floor 1 m from the wall as shown in figure. Find the reaction forces of the wall and the floor.

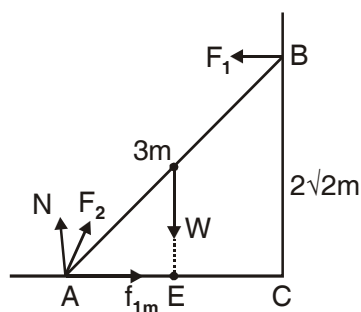

7. Calculate the ratio of radii of gyration of a circular ring and a disc of the same radius with respect to the axis passing through their centres and perpendicular to their planes.
8. An automobile moves on a road with a speed of 54 kmh^{-1} . The radius of its wheels is 0.35 m. What is the average negative torque transmitted by its brakes to a wheel if the vehicle is brought to rest in 15s? The moment of inertia of the wheel about the axis of rotation is 3 kg m^2 .

9. A rod of length L and mass M is hinged at point O . A small bullet of mass m hits the rod, as shown in figure. The bullet get embedded in the rod. Find the angular velocity of the system just after the impact.

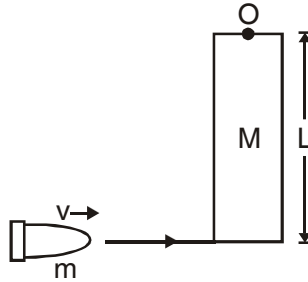

10. A solid disc and a ring, both of radius 10 cm are placed on a horizontal table simultaneously, with initial angular speed equal to $10\pi \text{ rad s}^{-1}$. Which of the two will start to roll earlier? The coefficient of kinetic friction is $\mu_k = 0.2$

ANSWERS

- $(x, y) = (0.54 \text{ m}, 0.36 \text{ m})$
- Velocity of COM = $\frac{31\hat{i} - 34\hat{j} + 15\hat{k}}{4} \text{ ms}^{-1}$
- COM of resulting portion lies at $R/6$ from the centre of the original disc in a direction opposite to the centre of the cut out portion.
- $\alpha = 4\pi \text{ rad s}^{-1}$

$$n = 576$$

- $m = 66.0 \text{ g}$

$$6. \quad F_2 = \sqrt{f^2 + N^2}$$

$$= \sqrt{34.6^2 + 196^2} = 199.0 \text{ N}$$

If F_2 makes an angle α with the horizontal then

$$\tan \alpha = \frac{N}{f} = 5.6568$$

$$\alpha = 80^\circ$$

$$7. \frac{K_{\text{ring}}}{K_{\text{disc}}} = \frac{R}{R/\sqrt{2}} = \frac{\sqrt{2}}{1}$$

$$8. \alpha = \frac{\omega - \omega_0}{t} = -\frac{1}{0.35} \text{rads}^{-2}$$

$$\tau = I\alpha = -8.57 \text{kgm}^2\text{s}^{-2}$$

9. Using conservation of angular momentum

$$L_{\text{initial}} = L_{\text{final}}$$

$$M V L = I\omega$$

$$\text{or } M V L = \frac{M + 3m}{3} L^2 \omega$$

$$\text{or } \omega = \frac{3mv}{(M + 3m)L}$$

10. The disc begins to roll earlier than the ring.

ROTATIONAL MOTION (5 MARKS)

- Obtain the expression for the linear acceleration of a cylinder rolling down an inclined plane and hence find the condition for the cylinder to roll down without slipping.
- Prove the result that the velocity V of translation of a rolling body (like a ring, disc, cylinder or sphere) at the bottom of an inclined plane of a height h is given by

$$v^2 = \frac{2gh}{1 + \frac{k^2}{R^2}}$$

where K = Radius of gyration of body about its symmetry axis, and R is radius of body. The body starts from rest at the top of the plane.

- A light string is wound round a cylinder and carries a mass tied to it at the free end. When the mass is released, calculate.

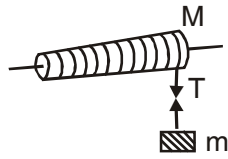

- (a) the linear acceleration of the descending mass
 - (b) angular acceleration of the cylinder
 - (c) Tension in the string.
4. State the theorem of
- (i) perpendicular axis (ii) parallel axis.

Find the moment of inertia of a rod of mass M and length L about an axis perpendicular to it through one end. Given the moment of inertia about an

axis perpendicular to rod and through COM is $\frac{1}{12}ML^2$

UNIT – VI

GRAVITATION

- **Newton's law of gravitation.** It states that the gravitational force of attraction acting between two bodies of the universe is directly proportional to the product of their masses and is inversely proportional to the square of the distance between them, *i.e.*, $F = G \frac{m_1 m_2}{r^2}$; where G is the universal gravitational constant.

The value of $G = 6.67 \times 10^{-11} \text{ Nm}^2 \text{ kg}^{-2}$

- **Gravity :** It is the force of attraction exerted by earth towards its centre on a body lying on or near the surface of earth.
- **Acceleration due to gravity (g).** It is defined as the acceleration set up in a body while falling freely under the effect of gravity alone. It is a vector quantity.

$$g = \frac{GM}{R^2}$$

where M and R are the mass and radius of the earth.

- **Variation of acceleration due to gravity.**

(i) **Effect of altitude,** $g' = \frac{g R^2}{(R+h)^2}$ and $g' = g \left(1 - \frac{2h}{R}\right)$

The first relation is valid when h is comparable with R and the second relation is valid when $h \ll R$. The value of g decreases with increase in h .

(ii) **Effect of depth,** $g' = g \left(1 - \frac{d}{R}\right)$

The acceleration due to gravity decreases with increase in depth d and becomes zero at the centre of earth.

- **Gravitational field.** It is the space around a material body in which its gravitational pull can be experienced by other bodies.

The intensity of gravitational field at a point at a distance r from the centre of the body of mass M is given by $I = GM/r^2 = g$ (acceleration due to gravity).

- **Gravitational potential.** The gravitational potential at a point in a gravitational field is defined as the amount of work done in bringing a body of unit mass from infinity to that point without acceleration. Gravitational

potential at a point,
$$V = \frac{\text{work done}(W)}{\text{test mass}(m_0)} = \frac{GM}{r}$$

- Gravitational potential energy $U = \text{gravitational potential} \times \text{mass of body}$

$$= -\frac{GM}{r} \times m$$

Gravitational intensity (I) is related to gravitational potential (V) at a point

by the relation, $-\frac{dv}{dr}$

- **Satellite.** A satellite is a body which is revolving continuously in an orbit around a comparatively much larger body.

(i) **Orbital speed of a satellite** when it is revolving around earth at height h is given by

$$v_0 = R \sqrt{\frac{g}{R+h}}$$

When the satellite is orbiting close to the surface of earth, i.e., $h \ll R$, then

$$v_0 = R \sqrt{\frac{g}{R}} = \sqrt{gR}$$

(ii) **Time period of satellite (T).** It is the time taken by the satellite to complete one revolution around the earth.

$$T = \frac{2\pi(R+h)}{v_0} = \frac{2\pi}{R} \sqrt{\frac{(R+h)^3}{g}}$$

(iii) Height of satellite above the earth's surface :

$$h = \left(\frac{T^2 R^2 g}{4\pi^2} \right)^{1/3} - R$$

(iv) Total energy of satellite, $E = \text{P.E.} + \text{K.E.}$

$$E = -\frac{GMm}{(R+h)} + \frac{1}{2}mv_0^2 = -\frac{GMm}{(R+h)} + \frac{1}{2}m \left(\frac{GM}{R+h} \right) = -\frac{GMm}{2(R+h)}$$

If the satellite is orbiting close to earth, then $r = R$. Now total energy of satellite.

$$E = -\frac{GMm}{2R}$$

(v) Binding energy of satellite. $= -E = \frac{GMm}{2r}$

- **Escape speed.** The escape speed on earth is defined as the minimum speed with which a body has to be projected vertically upwards from the surface of earth so that it just crosses the gravitational field of earth. Escape velocity v_e is given by,

$$v_e = \sqrt{\frac{2GM}{R}} = \sqrt{2gR}$$

For earth, the value of escape speed is 11.2 km s^{-1} .

VERY SHORT ANSWER TYPE QUESTION (1 MARK)

- Q 1. The mass of moon is nearly 10% of the mass of the earth. What will be the gravitational force of the earth on the moon, in comparison to the gravitational force of the moon on the earth?
- Q 2. Why does one feel giddy while moving on a merry round?
- Q 3. Name two factors which determine whether a planet would have atmosphere or not.
- Q 4. The force of gravity due to earth on a body is proportional to its mass, then why does a heavy body not fall faster than a lighter body?

- Q 5. The force of attraction due to a hollow spherical shell of uniform density on a point mass situated inside is zero, so can a body be shielded from gravitational influence?
- Q 6. The gravitational force between two bodies is 1 N if the distance between them is doubled, what will be the force between them?
- Q 7. A body of mass 5 kg is taken to the centre of the earth. What will be its (i) mass (ii) weight there.
- Q 8. Why is gravitational potential energy negative?
- Q 9. A satellite revolves close to the surface of a planet. How is its orbital velocity related with escape velocity of that planet.
- Q 10. Does the escape velocity of a body from the earth depend on (i) mass of the body (ii) direction of projection
- Q 11. Identify the position of sun in the following diagram if the linear speed of the planet is greater at C than at D.

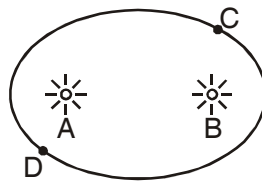

- Q 12. A satellite does not require any fuel to orbit the earth. Why?
- Q 13. A satellite of small mass burns during its descent and not during ascent. Why?
- Q 14. Is it possible to place an artificial satellite in an orbit so that it is always visible over New Delhi?
- Q 15. If the density of a planet is doubled without any change in its radius, how does 'g' change on the planet.
- Q 16. Mark the direction of gravitational intensity at (i) centre of a hemispherical shell of uniform mass density (ii) any arbitrary point on the upper surface of hemisphere.
- Q 17. Why an astronaut in an orbiting space craft is not in zero gravity although weight less?
- Q 18. Write one important use of (i) geostationary satellite (ii) polar satellite.

- Q 19. A binary star system consists of two stars A and B which have time periods T_A and T_B , radius R_A and R_B and masses m_A and m_B which of the three quantities are same for the stars. Justify.
- Q 20. The time period of the satellite of the earth is 5 hr. If the separation between earth and satellite is increased to 4 times the previous value, then what will be the new time period of satellite.
- Q 21. The distance of Pluto from the sun is 40 times the distance of earth if the masses of earth and Pluto be equal, what will be ratio of gravitational forces of sun on these planets.
- Q 22. If suddenly the gravitational force of attraction between earth and satellite become zero, what would happen to the satellite?

SHORT ANSWER TYPE QUESTIONS (2 MARKS)

- Q 1. If the radius of the earth were to decrease by 1%, keeping its mass same, how will the acceleration due to gravity change?
- Q 2. If 'g' be the acceleration due to gravity on earth's surface. Calculate the gain in potential energy of an object of mass m raised from the surface of earth to a height equal to the radius of earth in term of 'g'.
- Q 3. A satellite is moving round the earth with velocity v_0 what should be the minimum percentage increase in its velocity so that the satellite escapes.
- Q 4. Two planets of radii r_1 and r_2 are made from the same material. Calculate the ratio of the acceleration due to gravity on the surface of the planets.
- Q 5. If earth has a mass 9 times and radius 4 times than that of a planet 'P'. Calculate the escape velocity at the planet 'P' if its value on earth is 11.2 km s^{-1}
- Q 6. A black hole is a body from whose surface nothing can escape. What is the condition for a uniform spherical body of mass M to be a black hole? What should be the radius of such a black hole if its mass is nine times the mass of earth?
- Q 7. At what height from the surface of the earth will the value of 'g' be reduced by 36% of its value at the surface of earth.
- Q 8. At what depth is the value of 'g' same as at a height of 40 km from the surface of earth.

- Q 9. The mean orbital radius of the earth around the sun is 1.5×10^8 km. Calculate mass of the sun if $G = 6.67 \times 10^{-11} \text{ N m}^2/\text{kg}^{-2}$?
- Q 10. Draw graphs showing the variation of acceleration due to gravity with (i) height above earth is surface (ii) depth below the earth's surface.
- Q 11. Which planet of the solar system has the greatest gravitational field strength? What is the gravitational field strength of a planet where the weight of a 60 kg astronaut is 300 N.
- Q 12. Two satellites are at different heights from the surface of earth which would have greater velocity. Compare the speeds of two satellites of masses m and $4m$ and radii $2R$ and R respectively.
- Q 13. What is (i) inertial mass, (ii) gravitational mass. Are the two different?
- Q 14. Why the space rockets are generally launched west to East?
- Q 15. Explain why a tennis ball bounces higher on hills than in plane?
- Q 16. The gravitational force on the earth due to the sun is greater than moon. However tidal effect due to the moon's pull is greater than the tidal effect due to sun. Why?
- Q 17. The mass of moon is $\frac{M}{81}$ (where M is mass of earth). Find the distance of the point where the gravitational field due to earth and moon cancel each other. Given distance of moon from earth is $60 R$, where R is radius of earth.
- Q 18. The figure shows elliptical orbit of a planet m about the sun S . The shaded area of SCD is twice the shaded area SAB . If t_1 is the time for the planet to move from D to C and t_2 is time to move from A to B , what is the relation between t_1 and t_2 ?

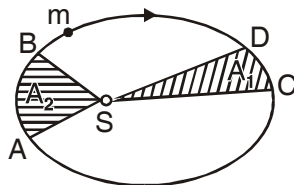

- Q 19. Calculate the energy required to move a body of mass m from an orbit of radius $2R$ to $3R$.

- Q 20. A man can jump 1.5 m high on earth. Calculate the height he may be able to jump on a planet whose density is one quarter that of the earth and whose radius is one third of the earth.

SHORT ANSWER TYPE QUESTIONS (3 MARKS)

- Q 1. Define gravitational potential at a point in the gravitational field. Obtain a relation for it. What is the position at which it is (i) maximum (ii) minimum.
- Q 2. Find the potential energy of a system of four particles, each of mass m , placed at the vertices of a square of side a . Also obtain the potential at the centre of the square.
- Q 3. Three mass points each of mass m are placed at the vertices of an equilateral triangle of side l . What is the gravitational field and potential at the centroid of the triangle due to the three masses.
- Q 4. Briefly explain the principle of launching an artificial satellite. Explain the use of multistage rockets in launching a satellite.
- Q 5. In a two stage launch of a satellite, the first stage brings the satellite to a height of 150 km and the 2nd stage gives it the necessary critical speed to put it in a circular orbit. Which stage requires more expenditure of fuel? Given mass of earth = 6.0×10^{24} kg, radius of earth = 6400 km
- Q 6. The escape velocity of a projectile on earth's surface is 11.2 km s^{-1} . A body is projected out with thrice this speed. What is the speed of the body far away from the earth? Ignore the presence of the sun and other planets.
- Q 7. A satellite orbits the earth at a height 'R' from the surface. How much energy must be expended to rocket the satellite out of earth's gravitational influence?
- Q 9. Deduce the law of gravitation from Kepler's laws of planets and motion.
- Q 10. Mention at least three conditions under which weight of a person can become zero.

LONG ANSWER TYPE QUESTIONS (5 MARKS)

- Q 1. What is acceleration due to gravity?
Obtain relations to show how the value of 'g' changes with (i) altitude
(ii) depth

- Q 2. Define escape velocity obtain an expression for escape velocity of a body from the surface of earth? Does the escape velocity depend on (i) location from where it is projected (ii) the height of the location from where the body is launched.
- Q 3. State Kepler's three laws of planetary motion. Prove the second and third law.
- Q 4. Derive expression for the orbital velocity of a satellite and its time period.
What is a geostationary satellite. Obtain the expression for the height of the geostationary satellite.
- Q 5. State universal law of gravitation. Explain briefly how Newton discovered the universal law of gravitation.
- Q 6. Define the term gravitational potential energy. Is it a scalar or vector? Derive an expression for the gravitational potential energy at a point in the gravitational field of earth.

NUMERICALS

- Q 1. The mass of planet Jupiter is 1.9×10^{27} kg and that of the sun is 1.99×10^{30} kg. The mean distance of Jupiter from the Sun is 7.8×10^{11} m. Calculate gravitational force which sun exerts on Jupiter, and the speed of Jupiter.
- Q 2. A mass 'M' is broken into two parts of masses m_1 and m_2 . How are m_1 and m_2 related so that force of gravitational attraction between the two parts is maximum.
- Q 3. If the radius of earth shrinks by 2%, mass remaining constant. How would the value of acceleration due to gravity change ?
- Q 4. A body hanging from a spring stretches it by 1 cm at the earth's surface. How much will the same body stretch at a place 1600 km above the earth's surface? Radius of earth 6400 km.
- Q 5. Imagine a tunnel dug along a diameter of the earth. Show that a particle dropped from one end of the tunnel executes simple harmonic motion. What is the time period of this motion?
- Q 6. The gravitational field intensity at a point 10,000 km from the centre of the earth is 4.8 N kg^{-1} . Calculate gravitational potential at that point.

- Q 7. A geostationary satellite orbits the earth at a height of nearly 36000 km. What is the potential due to earth's gravity at the site of this satellite (take the potential energy at ∞ to be zero). Mass of earth is 6×10^{24} kg, radius of earth is 6400 km.
- Q 8. How much faster than the present speed should the earth rotate so that bodies lying on the equator may fly off into space.
- Q 9. The distance of Neptune and Saturn from the sun is nearly 10^{13} m and 10^{12} m respectively. Assuming that they move in circular orbits, then what will be the ratio of their periods.
- Q 10. Let the speed of the planet at perihelion P in fig be v_p and Sun planet distance SP be r_p . Relate (r_p, v_p) to the corresponding quantities at the aphelion (r_A, v_A) . Will the planet take equal times to traverse BAC and CPB?

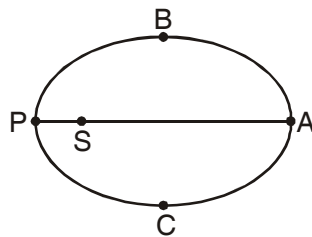

ANSWER FOR VERY SHORT QUESTIONS (1 MARK)

- Both forces will be equal in magnitude as gravitational force is a mutual force between the two bodies.
- When moving in a merry go round, our weight appears to decrease when we move down and increases when we move up, this change in weight makes us feel giddy.
- (i) Value of acceleration due to gravity (ii) surface temperature of planet.
- $\therefore F = \frac{GMm}{R^2}$ $F \propto m$ but $g = \frac{Gm}{R^2}$ and does not depend on 'm' hence they bodies fall with same 'g'.
- No, the gravitational force is independent of intervening medium.
- $F = 1$ $F' = \frac{F}{4}$

7. Mass does not change.

8. Because it arises due to attractive force of gravitation.

9. $v_e = \sqrt{2} v_o \quad \therefore v_e = \sqrt{\frac{2GM}{R}} \quad v_o = \sqrt{\frac{GM}{R}}$ when $r = R$

11. No, $v_e = \sqrt{\frac{2GM}{R}}$

12. Sun should be at B as speed of planet is greater when it is closer to sun.

13. The gravitational force between satellite and earth provides the necessary centripetal force for the satellite to orbit the earth.

14. The speed of satellite during descent is much larger than during ascent, and so heat produced is large.

15. No, A satellite will be always visible only if it revolves in the equatorial plane, but New Delhi does not lie in the region of equatorial plane.

16. 'g' gets doubled as $g \propto \rho$ (density)

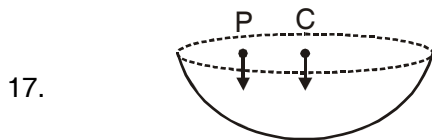

In both cases it will be downward

18. The astronaut is in the gravitational field of the earth and experiences gravity. However, the gravity is used in providing necessary centripetal force, so is in a state of free fall towards the earth.

19. Geostationary satellite are used for tele communication and polar satellite for remote sensing.

20. Angular velocity of binary stars are same is $\omega_A = \omega_B$,

$$\frac{2\pi}{T_A} = \frac{2\pi}{T_B} \Rightarrow T_A = T_B$$

21. $\frac{T_2^2}{T_1^2} = \left(\frac{R_2}{R_1}\right)^3 \Rightarrow T_2^2 = 64 \times 25 \Rightarrow T_2 = 40 \text{ hr}$

$$22. \frac{F_{es}}{F_{ps}} = \left(\frac{r_p}{r_e}\right)^2 = \left(\frac{40 r_e}{r_e}\right)^2 = 1600 : 1$$

23. The satellite will move tangentially to the original orbit with a velocity with which it was revolving.

SHORT ANSWER (2 MARKS)

$$1. \quad g = \frac{GM}{R^2} \text{ If } R \text{ decreases by } 1\% \text{ it becomes } \frac{99}{100}R$$

$$\therefore g' = \frac{GM}{(.99R)^2} = 1.02 \frac{GM}{R^2} = (1 + 0.02) \frac{GM}{R^2}$$

$$\therefore g' \text{ increases by } 0.02 \frac{GM}{R^2}, \text{ therefore increases by } 2\%.$$

$$2. \quad \text{Gain in PE} = -\frac{GMm}{2R} - \left(-\frac{GMm}{R}\right) = \frac{GMm}{2R} = \frac{gR^2 m}{2R} = \frac{1}{2}mgR$$

3. The maximum orbital velocity of a satellite orbiting near its surface is

$$v_o = \sqrt{gR} = \frac{v_e}{\sqrt{2}}$$

For the satellite to escape gravitational pull the velocity must become v_e

$$\text{But } v_e = \sqrt{2}v_o = 1.414 v_o = (1 + 0.414)v_o$$

This means that it has to increase 0.414 in 1 or 41.4%

\therefore The minimum increase required, as the velocity of satellite is maximum when it is near the earth.

$$4. \quad g = \frac{GM}{r^2} = \frac{G\rho \frac{4}{3}\pi r^3}{r^2} = \frac{4\pi}{3}G\rho r$$

$$g \propto r$$

$$\therefore \frac{g_1}{g_2} = \frac{r_1}{r_2}$$

$$5. \quad v_e = \sqrt{\frac{2GM}{R_e}} \quad v_p = \sqrt{\frac{2GM_p}{R_p}} \quad M_p = \frac{M}{9}, R_p = \frac{R_e}{4}$$

$$\therefore v_p = \sqrt{2G \frac{M}{9} \times \frac{4}{R_e}} = \frac{2}{3} \sqrt{\frac{2GM}{R_e}} = \frac{2}{3} \times 11.2 = \frac{22.4}{3}$$

$$= 7.47 \text{ km/sec}$$

6. According to Einstein's theory of relativity, the maximum speed of an object cannot exceed speed of light. Hence for a body to be a black hole

$$v_e = \sqrt{\frac{2GM}{R}} \leq c$$

If $M = 9 M_e = 9 \times 6 \times 10^{24} \text{ kg}$ then

$$R = \frac{2GM}{c^2} = \frac{2 \times 6.67 \times 10^{-11} \times 9 \times 6 \times 10^{24}}{(3 \times 10^8)^2}$$

$$= 8 \times 10^{-2} \text{ m}$$

$$= 8 \text{ cm}$$

$$7. \quad g' = 64\% \text{ of } g = \frac{64}{100} g$$

$$g' = g \frac{R^2}{(R+h)^2} = \frac{64}{100} g$$

$$\therefore \frac{R}{R+h} = \frac{8}{10}$$

$$h = \frac{R}{4} = 1600 \text{ km}$$

$$8. \quad g_d = g_h$$

$$g \left(1 - \frac{d}{R} \right) = g \left(1 - \frac{2h}{R} \right)$$

$$d = 2h = 2 \times 40 = 80 \text{ km}$$

9. $R = 1.5 \times 10^8 \text{ km} = 1.5 \times 10^{11} \text{ m}$

$T = 365 \text{ days} = 365 \times 24 \times 3600 \text{ s}$

Centripetal force = gravitational force

$$\frac{mv^2}{R} = \frac{GMm}{R^2} = \frac{m \left(\frac{2\pi R}{T} \right)^2}{R} = \frac{GMm}{R^2}$$

$$M_s = \frac{4\pi^2 R^3}{GT^2} = \frac{4 \times 9.87 \times (1.5 \times 10^{11})^3}{6.64 \times 10^{-11} \times (365 \times 24 \times 3600)^2}$$

$M_s = 2.01 \times 10^{30} \text{ kg}$

10.

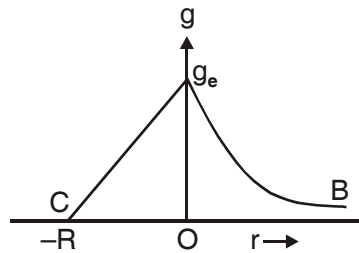

$g \propto \frac{1}{r^2}$ for $r > 0$ above surface of earth

$g \propto (R - d)$ for $r < 0$ below surface of earth

g is max for $r = 0$ on surface.

11. Jupiter has maximum gravitational field strength gravitational field strength

$$= \frac{F}{m} = \frac{300}{60}$$

$$= 5 \text{ N kg}^{-1}$$

12. $v_0 = \sqrt{\frac{GM}{(R+h)}}$

\therefore Velocity of satellite closer to the earth's surface will be greater

$$v_{01} = \sqrt{\frac{GM}{2R}} \quad v_{02} = \sqrt{\frac{GM}{R}}$$

$$\therefore \frac{v_{01}}{v_{02}} = \left(\frac{1}{\sqrt{2}} \right), \text{ where } M \text{ is mass of the planet,}$$

v_0 is independent of mass of the satellite.

13. Inertial mass is the measure of inertia of the body $= m_i = \frac{F}{a}$

Gravitational mass of a body determine the gravitational pull between earth and the body.

$$m_g = \frac{FR^2}{GM}$$

Both inertial mass and gravitational mass are not different but are equivalent.

14. Since the earth revolves from west to east, so when the rocket is launched from west to east the relative velocity of the rocket increases which helps it to rise without much consumption of fuel.
15. The value of 'g' on hills is less than at the plane, so the weight of tennis ball on the hills is lesser force than at planes that is why the earth attract the ball on hills with lesser force than at planes. Hence the ball bounces higher.
16. The tidal effect depends inversely on the cube of the distance, while gravitational force depends on the square of the distance.

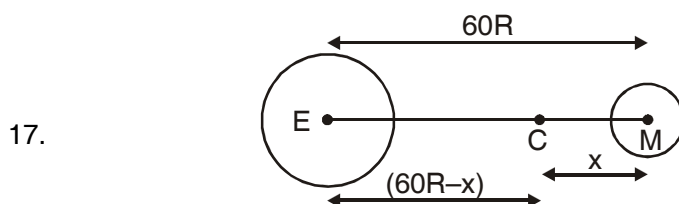

Gravitational field at C due to earth

= Gravitational field at C due to earth moon

$$\frac{GM}{(60R - x)^2} = \frac{GM/81}{x^2}$$

$$81x^2 = (60R - x)^2$$

$$9x = 60R - x$$

$$x = 6R$$

18. According to Kepler's IInd law areal velocity for the planet is constant

$$\therefore \frac{A_1}{t_1} = \frac{A_2}{t_2} \quad A_1 = 2A_2$$

$$\therefore \frac{2A_2}{t_1} = \frac{A_2}{t_2}$$

$$t_1 = 2t_2$$

19. Gravitational P.E of mass m in orbit of radius $R = U = -\frac{GMm}{R}$

$$\therefore U_i = -\frac{GMm}{2R}$$

$$U_f = -\frac{GMm}{3R}$$

$$\Delta U = U_f - U_i = GMm \left[\frac{1}{2} - \frac{1}{3} \right]$$

$$= \frac{GMm}{6R}$$

20. $g = \frac{4}{3}\pi GR\rho$

$$g' = \frac{4}{3}\pi GR'\rho'$$

The gain in P.E at the highest point will be same in both cases. Hence

$$mg'h' = mgh$$

$$h' = \frac{mgh}{mg'} = \frac{m \times \frac{4}{3} \pi GR \rho h}{m \frac{4}{3} \pi GR' \rho'}$$

$$= \frac{R \rho h}{R' \rho'} = \frac{3R' \times 4\rho' \times 1.5}{R' \times \rho'}$$

$$= 18 \text{ m}$$

ANSWER FOR 3 MARKS QUESTIONS

3.

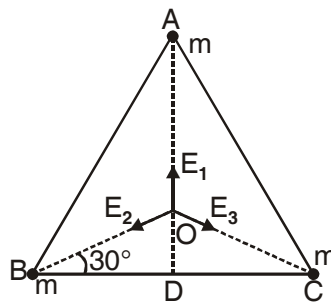

$$E_1 = \frac{GM}{(OA)^2}$$

$$E_2 = \frac{GM}{(OB)^2}$$

$$E_3 = \frac{GM}{(OC)^2}$$

$$\text{From } \triangle ODB \text{ } \cos 30^\circ = \frac{BD}{OB} = \frac{\ell/2}{OB}$$

$$OB = \frac{\ell/2}{\cos 30^\circ} = \frac{\ell}{2 \times \frac{\sqrt{3}}{2}} = \frac{\ell}{\sqrt{3}}$$

Gravitational field at O due to m at A, B and C is say \vec{E}_1, \vec{E}_2 & \vec{E}_3

$$E = \sqrt{E_2^2 + E_3^2 + 2E_2E_3\cos 120^\circ}$$

$$= \sqrt{\left(\frac{GM}{l^2}\right)^2 + \left(\frac{3Gm}{l}\right)^2 + 2\left(\frac{3GM}{l}\right)\left(\frac{3GM}{l}\right)\left(-\frac{1}{2}\right)}$$

$$= \frac{3GM}{l} \text{ along OD}$$

\vec{E} is equal and opposite to \vec{E}_1

\therefore net gravitational field = zero

As gravitational potential is scalar

$$V = V_1 + V_2 + V_3$$

$$= -\frac{GM}{OA} - \frac{GM}{OB} - \frac{GM}{OC}$$

$$V = -\frac{3GM}{l/\sqrt{3}} = -3\sqrt{3}\frac{Gm}{l}$$

5. Work done on satellite in first stage = $W_1 = \text{PE at } 150 \text{ km} - \text{PE at the surface}$

$$W_1 = -\frac{GMm}{R+h} - \left(-\frac{GMm}{R}\right)$$

$$= \frac{GMmh}{R(R+h)}$$

Work done on satellite in 2nd stage = $W_2 = \text{energy required to give orbital velocity } v_0$

$$= \frac{1}{2}mv_0^2 = \frac{1}{2}\left(\frac{GMm}{R+h}\right)$$

$$\frac{W_1}{W_2} = \frac{2h}{R} = \frac{2 \times 150}{6400} = \frac{3}{64} < 1$$

$\therefore W_2 > W_1$ so second stage requires more energy

6. $v_e = 11.2 \text{ kms}^{-1}$, velocity of projection = $v = 3v_e$ Let m be the mass of projectile and v_0 the velocity after it escapes gravitational pull.

By law of conservation of energy

$$\frac{1}{2}mv_0^2 = \frac{1}{2}mv^2 - \frac{1}{2}mv_e^2$$

$$\begin{aligned} v_0 &= \sqrt{v^2 - v_e^2} = \sqrt{9v_e^2 - v_e^2} = \sqrt{8v_e^2} \\ &= 22.4\sqrt{2} \\ &= 31.68 \text{ km s}^{-1} \end{aligned}$$

7. The energy required to pull the satellite from earth influence should be equal to the total energy with which it is revolving around the earth.

$$\text{The K.E. of satellite} = \frac{1}{2}mv^2 = \frac{1}{2}m \frac{GM}{R+h} \quad \therefore v = \sqrt{\frac{GM}{R+h}}$$

$$\text{The P.E of satellite} = -\frac{GMm}{R+h}$$

$$\therefore \text{T.E.} = \frac{1}{2} \frac{mGM}{(R+h)} - \frac{GMm}{(R+h)} = -\frac{1}{2} \frac{GMm}{(R+h)}$$

$$\therefore \text{Energy required will be} \left(+\frac{1}{2} \frac{GMm}{(R+h)} \right)$$

9. Suppose a planet of mass m , moves around the sun in a circular orbit of radius ' r ' with velocity v .

$$\text{Then centripetal force } F = \frac{mv^2}{r}$$

$$\text{But } v = \frac{2\pi r}{T}$$

$$F = m \frac{4\pi^2 r^2}{rT^2} = \frac{mr4\pi^2}{T^2}$$

According to Kepler's IIIrd law

$$T^2 \propto r^3$$

$$T^2 = k r^3$$

$$\therefore F = \frac{mr \cdot 4\pi^2}{k r^3} = \frac{4\pi^2 m}{k r^2} = \frac{4\pi^2}{k} \frac{m}{r^2}$$

The force between planet and sun must be mutual, so must be proportional to mass of sun.

$$\frac{4\pi^2}{k} \propto m \Rightarrow \frac{4\pi^2}{k} = GM$$

$$\therefore F = \frac{GMm}{r^2} \text{ This is Newton's law of gravitation}$$

10. (i) When the person is at centre of earth.
(ii) When the person is at the null points in space (at these points the gravitational forces due to different masses cancel each other)
(iii) when a person is standing in a freely falling lift.
(iv) When a person is inside a space craft which is orbiting around the earth.

ANSWER FOR NUMERICALS

$$\begin{aligned} 1. \quad F &= \frac{GMm}{r^2} \\ &= \frac{6.67 \times 10^{-11} \times 1.99 \times 10^{30} \times 1.9 \times 10^{27}}{(7.8 \times 10^{11})^2} \end{aligned}$$

$$F = 4.1 \times 10^{23} \text{ N}$$

$$\therefore F = \frac{mv^2}{r} \Rightarrow v = \sqrt{\frac{Fr}{m}} = \sqrt{\frac{GMm}{r^2} \times \frac{r}{m}}$$

$$v = \sqrt{\frac{GM}{r}} = \sqrt{\frac{6.67 \times 10^{-11} \times 1.9 \times 10^{30}}{7.8 \times 10^{11}}}$$

$$v = 1.3 \times 10^4 \text{ m s}^{-1}$$

2. Let $m_1 = m$ then $m_2 = M - m$

Force between them when they are separated by distance 'r'

$$F = \frac{Gm(M-m)}{r^2} = \frac{G}{r^2}(Mm - m^2)$$

For F to be maximum, differentiate F w.r.t m and equate to zero

$$\frac{dF}{dm} = \frac{G}{r^2}(M - 2m) = 0$$

$$M = 2m; \quad m = \frac{M}{2}$$

$$\therefore m_1 = m_2 = \frac{M}{2}$$

3. increases by 4%

4. In equilibrium $mg = kx$, $g = \frac{GM}{R^2}$

$$\text{at height } h \quad mg' = kx', \quad g' = \frac{GM}{(R+h)^2}$$

$$\frac{g'}{g} = \frac{x'}{x} = \frac{R^2}{(R+h)^2}$$

$$\frac{x'}{x} = \frac{(6400)^2}{(6400 + 1600)^2} = \frac{16}{25} \quad \therefore x' = \frac{16}{25} \times 1 \text{ cm} = 0.64 \text{ cm}$$

- 5.

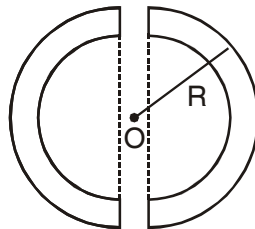

The acceleration due to gravity at a depth below the earth's surface is given by

$$g_d = g \left(1 - \frac{d}{R} \right) = g \left(\frac{R-d}{R} \right)$$

$$= \frac{g}{R} y \text{ where } y \text{ is distance from centre of earth}$$

$$g_d \propto y$$

As acceleration is proportional to displacement and is directed towards mean position, the motion would be S.H.M

$$T = \text{Time period} = 2\pi \sqrt{\frac{\text{displacement}}{\text{acceleration}}}$$

$$= 2\pi \sqrt{\frac{y}{g_d}}$$

$$= 2\pi \sqrt{\frac{R}{a}}$$

6. Gravitational intensity = $E = \frac{GM}{R^2}$

Gravitational potential $V = -\frac{GM}{R}$

$$\therefore \frac{V}{E} = -R$$

or, $V = -E \times R$

or $V = -4.8 \times 10,000 \times 10^3 = -4.8 \times 10^7 \text{ J kg}^{-1}$

7. $U = \text{Potential at height } h = -\frac{GM}{R+h}$

$$U = -\frac{6.67 \times 10^{-11} \times 6 \times 10^{24}}{6.4 \times 10^6 + 36 \times 10^6} = -9.44 \times 10^6 \text{ J/kg}$$

8. The speed of earth = $v = \omega R = \frac{2\pi}{T} \times R$

at present

$$v = \frac{2\pi \times 6400 \times 10^3}{24 \times 3600}$$

The gravitational force should be equal to the centripetal force so that

centrifugal force, given by $\frac{mv'^2}{R}$

$$F = \frac{GMm}{R^2} = \frac{mv'^2}{R}$$

$$v' = \sqrt{\frac{GM}{R}} = \sqrt{\frac{6.67 \times 10^{-11} \times 6 \times 10^{24}}{6400 \times 10^3}}$$

$\therefore \frac{v'}{v} = 17$. \therefore The velocity should become 17 times the present velocity

9. By Kepler's IIIrd law

$$\left(\frac{T_n}{T_s}\right)^2 = \left(\frac{R_n}{R_s}\right)^3$$

$$\frac{T_n}{T_5} = \left(\frac{R_n}{R_s}\right)^{3/2} = \left(\frac{10^{13}}{10^{12}}\right)^{3/2} = 10^{3/2}$$

$$= 10\sqrt{10} = 10 \times 3.16 = 31.6$$

$\therefore T_n : T_s = 36.6 : 1$

10. The magnitude of angular momentum at P is $L_p = m_p r_p v_p$

Similarly magnitude of angular momentum at A is $L_A = m_A r_A v_A$

From conservation of angular momentum

$$m_p r_p v_p = m_A v_A r_A$$

$$\frac{v_P}{v_A} = \frac{r_A}{r_P}$$

$$\because r_A > r_P, \therefore v_P > v_A$$

area bound by SB & SC (SBAC > SBPC)

\therefore By 2nd law equal areas are swept in equal intervals of time. Time taken to transverse BAC > time taken to transverse CPB

UNIT – VII

PROPERTIES OF BULK MATTER

KEY CONCEPTS

- **Elasticity** : It is the property of the body by virtue of which the body regains its original configuration (length, volume or shape) when the deforming forces are removed.
- **Stress** : The internal restoring force acting per unit area of a deformed body is called stress, *i.e.*,

Stress = restoring force/area.

- **Strain** : It is defined as the ratio of change in configuration to the original configuration of the body *i.e.*, $\text{Strain} = \frac{\text{change in configuration}}{\text{original configuration}}$

Strain can be of three types : (i) Longitudinal strain (ii) Volumetric strain (iii) Shearing strain.

- **Hooke's law** : It states that the stress is directly proportional to strain within the elastic limit.
- **Modulus of Elasticity** or **Coefficient of elasticity** of a body is defined as the ratio of the stress to the corresponding strain produced, within the elastic limit.

Modulus of elasticity is of three types:

- (i) *Young's Modulus of elasticity (Y)*. It is defined as the ratio of normal stress to the longitudinal strain within the elastic limit, *i.e.*,

$$Y = \frac{\text{normal stress}}{\text{longitudinal strain}} = \frac{F/a}{\Delta l/l} = \frac{F}{a} \times \frac{l}{\Delta l}$$

- (ii) *Bulk Modulus of elasticity (K)*. It is defined as the ratio of normal stress to the volumetric strain within the elastic limit, *i.e.*,

$$B = \frac{\text{normal stress}}{\text{longitudinal strain}} = \frac{F/a}{\Delta V/V} = -\frac{F}{a} \times \frac{V}{\Delta V} = -\rho \frac{V}{\Delta V}$$

(iii) **Modulus of Rigidity (η)**. It is defined as the ratio of tangential stress to the shearing strain, within the elastic limit, *i.e.*,

$$\eta = \frac{\text{tangential stress}}{\text{shearing strain}} = \frac{F/a}{\theta} = \frac{F}{A\theta}$$

- Compressibility = $\frac{1}{\text{Bulk modulus}} = -\frac{\Delta V}{\rho V}$
- **Poisson's ratio (σ)** is defined as the ratio of lateral strain to the longitudinal strain, *i.e.*,

$$\sigma = \frac{\text{lateral strain}}{\text{longitudinal strain}} = \frac{-\Delta R/R}{\Delta l/l} = \frac{-\Delta R.l}{R.\Delta l}$$

Theoretical value of σ lies between -1 and $\frac{1}{+2}$. The practical value of σ lies between 0 and $+1/2$. If there is no change in the volume of wire on loading, then its Poisson's ratio is 0.5 .

- **Elastic potential energy stored per unit volume of a strained body**

$$u = \frac{1}{2} \times \text{stress} \times \text{strain} = \frac{(\text{stress})^2}{2Y} = \frac{Y \times (\text{strain})^2}{2}$$

where Y is the Young's modulus of elasticity of a solid body.

- Workdone in a stretched wire, $W = \frac{1}{2} \times \text{stress} \times \text{strain} \times \text{volume}$

$$= \frac{1}{2} \frac{F}{A} \times \frac{\Delta L}{L} \times AL = \frac{1}{2} F \times \Delta L = \frac{1}{2} \text{load} \times \text{extension}$$

- Total pressure at a point inside the liquid of density ρ at depth h is $P = h\rho g + P_0$ where P_0 is the atmospheric pressure.
- **Pascal's law** : This law states for the principle of transmission of pressure in liquids or gases. Pascal's law states that the increase in pressure at one point of the enclosed liquid in equilibrium of rest is transmitted equally to all other points of the liquid and also to the walls of the container, provided the effect of gravity is neglected.

- **Viscosity** : Viscosity is the property of a fluid by virtue of which an internal frictional force comes into play when the fluid is in motion and opposes the relative motion of its different layers.

Viscous drag F acting between two layers of liquid each of area A , moving with velocity gradient dv/dx is given by $F = \eta A dv/dx$

where η is the coefficient of viscosity of liquid.

SI unit of η is poiseuille of N s m^{-2} or Pascal-second

- **Stoke's law** : It states that the backward dragging force F acting on a small spherical body of radius r , moving through a medium of viscosity η , with velocity v is given by $F = 6 \pi \eta r v$.
- **Terminal velocity** : It is the maximum constant velocity acquired by the body while falling freely in a viscous medium. Terminal velocity v of a spherical body of radius r , density ρ while falling freely in a viscous medium

of viscosity η , density σ is given by $v = \frac{2r^2(\rho - \sigma)g}{9\eta}$

- **Stream line flow of a liquid** is that flow in which every particle of the liquid follows exactly the path of its preceding particle and has the same velocity in magnitude and direction as that of its preceding particle while crossing through that point.
- **Turbulent flow** : It is that flow of liquid in which the motion of the particles of liquid becomes disorderly or irregular.
- **Critical velocity** : It is that velocity of liquid flow, upto which the flow of liquid is a streamlined and above which its flow becomes turbulent. Critical velocity of a liquid (v_c) flowing through a tube is given by

$$v_c = \frac{N \eta}{\rho D}$$

where ρ is the density of liquid flowing through a tube of diameter D and η is the coefficient of viscosity of liquid. N = Reynold number

- **Equation of continuity**, a $v = \text{constant}$ where **a = area of cross section**
v = velocity of flow of liquid.
- **Bernoulli's Theorem** : It states that for the stream line flow of an ideal liquid, the total energy (the sum of pressure energy, the potential energy

and kinetic energy) per unit volume remains constant at every cross-section throughout the tube, *i.e.*,

$$P + \rho gh + \frac{1}{2}\rho v^2 = \text{a constant,} \quad \text{or} \quad \frac{P}{\rho g} + h + \frac{1}{2}\frac{v^2}{g} = \text{another constant}$$

- **Torricelli's Theorem** : It states that the velocity of efflux, *i.e.*, the velocity with which the liquid flows out of an orifice is equal to that which a freely falling body would acquire in falling through a vertical distance equal to the depth of orifice below the free surface of liquid. Quantitatively velocity of efflux, $v = \sqrt{2gh}$, where h is the depth of orifice below the free surface of liquid.
- **Surface tension** : It is the property of the liquid by virtue of which the free surface of liquid at rest tends to have minimum surface area and as such it behaves as a stretched membrane. Surface tension,

$$S = \frac{F}{l}$$

where F is the force acting on the imaginary line of length l , drawn tangentially to the liquid surface at rest. SI unit of surface tension is Nm^{-1}

- **Surface energy** = surface tension \times area of the liquid surface

(i) Excess of pressure inside a liquid drop, $P = 2 S/R$

(ii) Excess of pressure inside a soap bubble, $P = 4 S/R$

where S is the surface tension and R is the radius of the drop or bubble.

- **Angle of contact** : The angle of contact between a liquid and a solid is defined as the angle enclosed between the tangents to the liquid surface and the solid surface inside the liquid, both the tangents being drawn at the point of contact of the liquid with the solid.
- **Capillarity** : The phenomenon of rise or fall of liquid in a capillary tube is called capillarity. The height (h) through which a liquid will rise in a capillary tube of radius r which wets the sides of the tube will be given by

$$h = \frac{2S\cos\theta}{r\rho g}$$

where S is the surface tension of liquid, θ is the angle of contact, ρ is the density of liquid and g is the acceleration due to gravity.

VERY SHORT ANSWER TYPE QUESTIONS (1 MARK)

1. Define term (i) stress (ii) strain
2. Differentiate the properties plasticity and elasticity of material
3. Draw stress – strain curve for elastomers (elastic tissue of Aorta)
4. How are we able to break a wire by repeated bending?
5. What is the value of bulk modulus for an incompressible liquid?
6. Define Poisson's ratio? Does it have any unit?
7. What is elastic fatigue?
8. Why is it easier to swim in sea water than in the river water?
9. Railway tracks are laid on large sized wooden sleepers. Why?
10. The dams of water reservoir are made thick near the bottom. Why?
11. Why is it difficult to stop bleeding from a cut in human body at high altitudes?
12. The blood pressure in human is greater at the feet than at the brain. Why?
13. Define coefficient of viscosity and write its SI unit.
14. Why machine parts get jammed in winter?
15. Why are rain drops spherical?
16. Why do paints and lubricants have low surface tension?
17. What will be the effect of increasing temperature on (i) angle of contact (ii) surface tension.
18. For solids with elastic modulus of rigidity, the shearing force is proportional to shear strain. On what factor does it depend in case of fluids?
19. How does rise in temperature effect (i) viscosity of gases (ii) viscosity of liquids.

20. Explain why detergents should have small angle of contact?
21. Write the dimensions of coefficient of viscosity and surface tension.
22. Obtain a relation between SI unit and cgs unit of coefficient of viscosity.
23. Explain, how the use of parachute helps a person jumping from an aeroplane.
24. Why two ships moving in parallel directions close to each other get attracted?
25. Why the molecules of a liquid lying near the free surface possess extra energy?
26. Why is it easier to wash clothes in hot water soap solution?
27. Why does mercury not wet glass?
28. Why ends of a glass tube become rounded on heating?
29. What makes rain coats water proof?
30. What happens when a capillary tube of insufficient length is dipped in a liquid?
31. Does it matter if one uses gauge pressure instead of absolute pressure in applying Bernoulli's equation?
32. State Wein's displacement law for black body radiation.
33. State Stefan Boltzmann law.
34. Name two physical changes that occur on heating a body.
35. Distinguish between heat and temperature.
36. Which thermometer is more sensitive a mercury or gas thermometer?
37. Metal disc has a hole in it. What happens to the size of the hole when disc is heated?
38. Name a substance that contracts on heating.
39. A gas is free to expand what will be its specific heat?

40. What is Deby's temperature?
41. What is the absorptive power of a perfectly black body?
42. At what temperature does a body stop radiating?
43. If Kelvin temperature of an ideal black body is doubled, what will be the effect on energy radiated by it?
44. In which method of heat transfer does gravity not play any part?
45. Give a plot of Fahrenheit temperature versus celsius temperature
46. Why birds are often seen to swell their feather in winter?
47. A brass disc fits snugly in a hole in a steel plate. Should we heat or cool the system to loosen the disc from the hole.

SHORT ANSWER TYPE QUESTIONS (2 MARKS)

1. State Hooke's law. Deduce expression for young's modulus of material of a wire of length 'l', radius of crossection 'r' loaded with a body of mass M producing an extension Δl in it.
2. A wire of length l area of crossection A and young's modulus Y is stretched by an amount x. What is the work done?
3. Prove that the elastic potential energy per unit volume is equal to $\frac{1}{2} \times \text{stress} \times \text{strain}$.
4. Define the term bulk modulus. Give its SI unit. Give its SI unit. Give the relation between bulk modulus and compressibility.
5. Define shear modulus. With the help of a diagram explain how shear modulus can be calculated.
6. Which is more elastic steel or rubber. Explain.
7. Two wires P and Q of same diameter are loaded as shown in the figure. The length of wire P is L m and its young's modulus is Y N/m² while length of wire a is twice that of P and its material has young's modulus half that of P. Compute the ratio of their elongation.

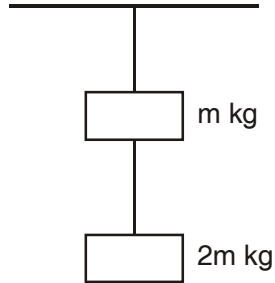

8. What is Reynold's number? Write its significance. On what factors does it depend.
9. Define surface tension and surface energy. Obtain a relation between them.
10. State and prove Torricelli's theorem for velocity of efflux.
11. Using dimensional method obtain, Stoke's law expression for viscous force $F = 6\pi \eta a v$
12. The fig (a) & (b) refer to the steady flow of a non viscous liquid which of the two figures is incorrect? Why?

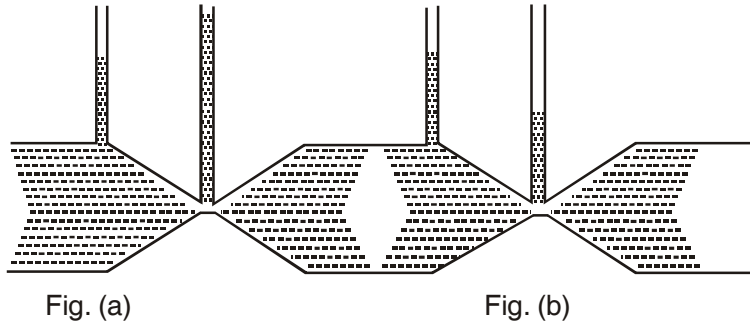

13. The fig below shows a thin liquid supporting a small weight $4.5 \times 10^{-2} \text{N}$. What is the weight supported by a film of same liquid at the same temperature in fig (b) & (c) Explain your answer.

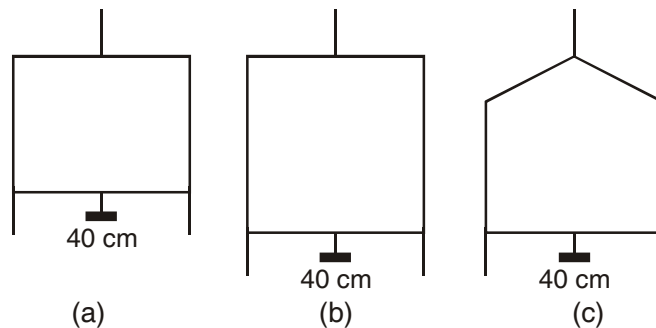

14. Two soap bubbles of different diameter are in contact with a certain portion common to both the bubbles. What will be the shape of the common boundary as seen from inside the smaller bubble? Support your answer with a neat diagram and justify your answer.
15. During blood transfusion the needle is inserted in a vein where gauge pressure is p_g and atmospheric pressure is p . At what height must the blood container be placed so that blood may just enter the vein. Given density of blood is ρ .
16. Why we cannot remove a filter paper from a funnel by blowing air into narrow end.
17. On a hot day, a car is left in sunlight with all windows closed. Explain why it is considerably warmer than outside, after some time?
18. Name the suitable thermometers to measure the following temperatures
 - (a) -100°C
 - (b) 80°C
 - (c) 780°C
 - (d) 2000°C
19. If a drop of water falls on a very hot iron, it does not evaporate for a long time. Why?
20. The earth without its atmosphere would be inhospitably cold. Why?
21. The coolant used in chemical or in a nuclear plant should have high specific heat. Why?
22. A sphere, a cube and a disc made of same material and of equal masses heated to same temperature of 200°C . These bodies are then kept at same lower temperature in the surrounding, which of these will cool (i) fastest, (ii) slowest, explain.
23.
 - (a) Why pendulum clocks generally go faster in winter and slow in summer.
 - (b) Why the brake drums of a car are heated when it moves down a hill at constant speed.
24. The plots of intensity versus wavelength for three blackbodies at temperature T_1 , T_2 and T_3 respectively are shown.

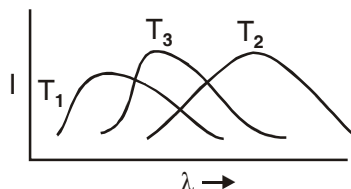

Arrange the temperature in decreasing order. Justify your answer.

25. The triple point of water is a standard fixed point in modern thermometry. Why? Why melting point of ice or boiling point of water not used as standard fixed points.

SHORT ANSWER TYPE QUESTION (3 MARKS)

- How is the knowledge of elasticity useful in selecting metal ropes used in cranes for lifting heavy loads.
- If the torque required to produce unit twist in a solid shaft of radius r , length l and made of material of modulus of rigidity η is given by

$$\tau = \frac{\pi \eta r^4}{2l}$$

Explain why hollow shafts are preferred to solid shafts for transmitting torque?

- Stress strain curve for two wires of material A and B are as shown in Fig.

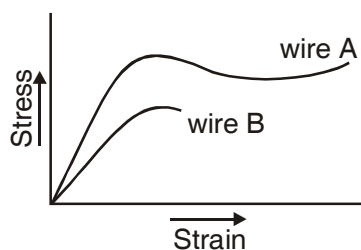

- which material is more ductile?
- which material has greater value of young modulus?
- which of the two is stronger material?
- which material is more brittle?

4. State Pascal's law for fluids with the help of a neat labelled diagram explain the principle and working of hydraulic brakes.
5. A manometer reads the pressure of a gas in an enclosure as shown in the fig (a) when some of the gas is removed by a pump, the manometer reads as in fig (b) The liquid used in manometer is mercury and the atmospheric pressure is 76 cm of mercury. (i) Give absolute and gauge pressure of the gas in the enclosure for cases (a) and (b).

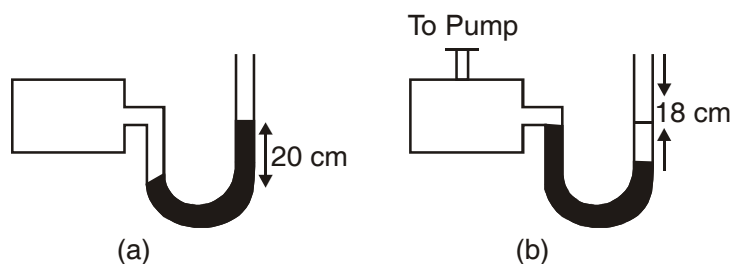

6. How would the levels change in (b) if 13.6 cm of H_2O (immiscible with mercury) are poured into the right limb of the manometer in the above numerical.
7. Define Capillarity and angle of contact. Derive an expression for the ascent of a liquid in a capillary tube.
8. The terminal velocity of a tiny droplet is v . N number of such identical droplets combine together forming a bigger drop. Find the terminal velocity of the bigger drop.
9. Two spherical soap bubble coalesce. If v be the change in volume of the contained air, A is the change in total surface area then show that $3PV + 4AT = 0$ where T is the surface tension and P is atmospheric pressure.
10. Give the principle of working of venturimeter. Obtain an expression for volume of liquid flowing through the tube per second.
11. A big size balloon of mass M is held stationary in air with the help of a small block of mass $M/2$ tied to it by a light string such that both float in mid air. Describe the motion of the balloon and the block when the string is cut. Support your answer with calculations.
12. Two vessels have the same base area but different shapes. The first vessel takes twice the volume of water that the second vessel requires to fill upto a particular common height. Is the force exerted by the water on

the base of the vessel the same? Why do the vessels filled to same height give different reading on weighing scale.

13. A liquid drop of diameter D breaks up into 27 tiny drops. Find the resulting change in energy. Take surface tension of liquid as σ .
14. Define the coefficients of linear expansion. Deduce relation between it and coefficient of superficial expansion and volume expansion.
15. Describe the different types of thermometers commonly used. Used the relation between temperature on different scales. Give four reasons for using mercury in a thermometer.
16. Two rods of different metals of coefficient of linear expansion α_1 and α_2 and initial length l_1 and l_2 respectively are heated to the same temperature. Find relation in α_1 , α_2 , l_1 and l_2 such that difference between their lengths remain constant.
17. Explain the principle of platinum resistance thermometer.
18. Draw a graph to show the anomalous behaviour of water. Explain its importance for sustaining life under water.
19. A steel rail of length 5m and area of cross section 40cm^2 is prevented from expanding while the temperature rises by 10°C . Given coefficient of linear expansion of steel is $1.2 \times 10^{-5} \text{ k}^{-1}$. Explain why space needs to be given for thermal expansion.
20. Define (i) Specific heat capacity (ii) Heat capacity (iii) Molar specific heat capacity at constant pressure and at constant volume and write their units.
21. Plot a graph of temperature versus time showing the change in the state of ice on heating and hence explain the process (with reference to latent heat)
22. What is the effect of pressure on melting point of a substance? What is regelation. Give a practical application of it.
23. What is the effect of pressure on the boiling point of a liquid. Describe a simple experiment to demonstrate the boiling of H_2O at a temperature much lower than 100°C . Give a practical application of this phenomenon.
24. State and explains the three modes of transfer of heat. Explains how the loss of heat due to these three modes is minimised in a thermos flask.

25. Define coefficient of thermal conductivity. Two metal slabs of same area of cross-section, thickness d_1 and d_2 having thermal conductivities K_1 and K_2 respectively are kept in contact. Deduce expression for equivalent thermal conductivity.

LONG ANSWER TYPE QUESTIONS (5 MARKS)

1. Draw and discuss stress versus strain graph, explaining clearly the terms elastic limit, permanent set, proportionality limit, elastic hysteresis, tensile strength.
2. Show that there is always an excess pressure on the concave side of the meniscus of a liquid. Obtain an expression for the excess pressure inside (i) a liquid drop (ii) liquid bubble (iii) air bubble inside a liquid.
3. State and prove Bernoulli's theorem. Give its limitation. Name any two applications of the principle.
4. Define terminal velocity. Obtain an expression for terminal velocity of a sphere falling through a viscous liquid. Use the formula to explain the observed rise of air bubbles in a liquid.
5. State Newton's law of cooling. Deduce the relations :
$$\log_e(T - T_0) = -kt + c$$
and
$$T - T_0 = C e^{-kt}$$
where the symbols have their usual meanings. Represent Newton's law of cooling graphically by using each of the above equations.
6. On what factors does the rate of heat conduction in a metallic rod in the steady state depend. Write the necessary expression and hence define the coefficient of thermal conductivity. Write its unit and dimensions.
7. Distinguish between conduction, convection and radiation.
8. What is meant by a black body. Explain how a black body may be achieved in practice. State and explain Stefan's law?
9. Explain the construction and working of a constant volume gas thermometer. What are its main drawbacks?
10. Discuss energy distribution of a black body radiation spectrum and explain Wien's displacement law of radiation and Stefan's law of heat radiation.

NUMERICALS

1. An aluminium wire 1m in length and radius 1mm is loaded with a mass of 40 kg hanging vertically. Young's modulus of Al is $7.0 \times 10^{10} \text{ N/m}^2$ Calculate (a) tensile stress (b) change in length (c) tensile strain and (d) the force constant of such a wire.
2. The average depth of ocean is 2500 m. Calculate the fractional compression $\left(\frac{\Delta V}{V}\right)$ of water at the bottom of ocean, given that the bulk modulus of water is $2.3 \times 10^9 \text{ N/m}^2$.
3. A force of $5 \times 10^3 \text{ N}$ is applied tangentially to the upper face of a cubical block of steel of side 30 cm. Find the displacement of the upper face relative to the lower one, and the angle of shear. The shear modulus of steel is $8.3 \times 10^{10} \text{ pa}$.
4. How much should the pressure on one litre of water be changed to compress it by 0.10%.
5. Calculate the pressure at a depth of 10 m in an Ocean. The density of sea water is 1030 kg/m^3 . The atmospheric pressure is $1.01 \times 10^5 \text{ pa}$.
6. In a hydraulic lift air exerts a force F on a small piston of radius 5cm. The pressure is transmitted to the second piston of radius 15 cm. If a car of mass 1350 kg is to be lifted, calculate force F that is to be applied.
7. How much pressure will a man of weight 80 kg exert on the ground when (i) he is lying and (2) he is standing on his feet. Given area of the body of the man is 0.6 m^2 and that of his feet is 80 cm^2 .
8. The manual of a car instructs the owner to inflate the tyres to a pressure of 200 k pa. (a) What is the recommended gauge pressure? (b) What is the recommended absolute pressure (c) If, after the required inflation of the tyres, the car is driven to a mountain peak where the atmospheric pressure is 10% below that at sea level, what will the tyre gauge read?
9. Calculate excess pressure in an air bubble of radius 6mm. Surface tension of liquid is 0.58 N/m.
10. Terminal velocity of a copper ball of radius 2 mm through a tank of oil at 20°C is 6.0 cm/s. Compare coefficient of viscosity of oil. Given $\rho_{\text{Cu}} = 8.9 \times 10^3 \text{ kg/m}^3$, $\rho_{\text{oil}} = 1.5 \times 10^3 \text{ kg/m}^3$

11. Calculate the velocity with which a liquid emerges from a small hole in the side of a tank of large cross-sectional area if the hole is 0.2m below the surface liquid ($g = 10 \text{ ms}^{-2}$).
12. A soap bubble of radius 1 cm expands into a bubble of radius 2cm. Calculate the increase in surface energy if the surface tension for soap is 25 dyne/cm.
13. A glass plate of 0.20 m^2 in area is pulled with a velocity of 0.1 m/s over a larger glass plate that is at rest. What force is necessary to pull the upper plate if the space between them is 0.003m and is filled with oil of $\eta = 0.01 \text{ Ns/m}^2$
14. The area of cross-section of a water pipe entering the basement of a house is $4 \times 10^{-4} \text{ m}^2$. The pressure of water at this point is $3 \times 10^5 \text{ N/m}^2$, and speed of water is 2 m/s. The pipe tapers to an area of cross section of $2 \times 10^{-4} \text{ m}^2$, when it reaches the second floor 8 m above the basement. Calculate the speed and pressure of water flow at the second floor.
15. A metal block of area 0.10 m^2 is connected to a 0.010 kg mass via a string that passes over an ideal pulley. A liquid with a film thickness of 0.30 mm is placed between the block and the table when released the block moves with a constant speed of 0.085 ms^{-1} . Find the coefficient of viscosity of the liquid.
16. Water rises to a height of 9 cm in a certain capillary tube. If in the same tube, level of Hg is depressed by 3 cm, compare the surface tension of water and mercury. Specific gravity of Hg is 13.6 and the angle of contact for Hg is 135°
17. Two stars radiate maximum energy at wavelength, $3.6 \times 10^{-7} \text{ m}$ respectively. What is the ratio of their temperatures?
18. Find the temperature of 149°F on kelvin scale.
19. A metal piece of 50 g specific heat $0.6 \text{ cal/g}^\circ\text{C}$ initially at 120°C is dropped in 1.6 kg of water at 25°C . Find the final temperature or mixture.
20. A iron ring of diameter 5.231 m is to be fixed on a wooden rim of diameter 5.243 m both initially at 27°C . To what temperature should the iron ring be heated so as to fit the rim (Coefficient of linear expansion of iron is $1.2 \times 10^{-5} \text{ k}^{-1}$?
21. 100g of ice at 0°C is mixed with 100 g of water at 80°C . The resulting temperature is 6°C . Calculate heat of fusion of ice.

22. Calculate heat required to convert 3kg of water at 0°C to steam at 100°C
Given specific heat capacity of H₂O = 4186 J kg⁻¹ K⁻¹ and latent heat of steam = 2.256 × 10⁶ J/kg
23. Given length of steel rod 15 cm; of copper 10 cm. Their thermal conductivities are 50.2 J – s m⁻¹ K⁻¹ and 385 J – s – m⁻¹ K⁻¹ respectively. Area of cross-section of steel is double of area of Copper rod?
24. A body at temperature 94°C cools to 86°C in 2 min. What time will it take to cool from 82°C to 78°C. The temperature of surrounding is 20°C.
25. A body re-emits all the radiation it receives. Find surface temperature of the body. Energy received per unit area per unit time is 2.835 watt/m² and $\sigma = 5.67 \times 10^{-8} \text{ W m}^{-2} \text{ K}^{-4}$.
26. At what temperature the resistance of thermometer will be 12% more of its resistance at 0°C (given temperature coefficient of resistance is $2.5 \times 10^{-3} \text{ }^\circ\text{C}^{-1}$?)

VERY SHORT ANSWER (1 MARK)

4. Repeated bending of wire decreases elastic strength and therefore it can be broken easily.
5. $K = \frac{\text{stress}}{\text{strain}} = \frac{\text{stress}}{0} = \infty$ Infinity
6. Poisson's ratio is the ratio of lateral strain to the longitudinal strain. It has no units.
7. It is the loss in strength of a material caused due to repeated alternating strains to which the material is subjected
8. The density of sea water is more than the density of river water, hence sea water gives more up thrust for the same volume of water displaced.
9. This spreads force due to the weight of the train on a larger area and hence reduces the pressure considerably and in turn prevents yielding of the ground under the weight of the train.
10. Pressure exerted by liquid column = $h \rho g$ so as 'h' increases ρ increases so to with stand high pressure dams are made thick near the bottom.

11. The atmospheric pressure is low at high altitudes. Due to greater pressure difference in blood pressure and the atmospheric pressure, it is difficult to stop bleeding from a cut in the body.
12. The height of blood column is quite large at feet than at the brain, hence blood pressure at feet is greater.
14. In winter i.e. at low temperature the viscosity of lubricants increases.
15. Due to surface tension the drops try to occupy minimum surface area, and for a given volume sphere has minimum surface area.
16. Low surface tension makes paints and lubricants to spread more effectively.
17. Angle of contact increases with increase of temperature while surface tension generally decreases with increase of temperature
18. Rate of Shear Strain.
19. Viscosity of gases increases while viscosity of liquid decreases.
20. Detergents should have small angle of contact so that they have low surface tension and greater ability to wet a surface. Further as $h = \frac{2T \cos\theta}{r\rho g}$ i.e. θ is small $\cos\theta$ will be large so h i.e. penetration will be high.
21. $[\eta] = M^1 L^{-1} T^{-1}$
 $[T] = M^1 T^{-2} L^0$
22. c.g.s unit of $\eta = \text{poise}$
S.I Unit of $\eta = \text{poiseuille or deca poise}$
 $1 \text{ poise} = 1 \text{ g cm}^{-1} \text{ s}^{-2} = 10^{-1} \text{ kg m}^{-1} \text{ s}^{-1}$
 $= 0.1 \text{ poiseuille}$
23. Viscous force on the parachute is large as $F = 6\pi \eta r v$, $F \propto r$, so its terminal velocity becomes small so the person hits the ground with this small velocity and does not get injured.

24. According to Bernoulli's theorem for horizontal flow $P + \frac{1}{2}\rho v^2 = \text{constant}$.
As speed of water between the ships is more than outside them pressure between them gets reduced & pressure outside is more so the excess pressure pushes the ships close to each other therefore they get attracted.
25. The molecules in a liquid surface have a net downward force (cohesion) on them, so work done in bringing them from within the body of liquid to the surface increases surface energy.
26. Hot water soap solution has small surface tension therefore can remove the dirt from clothes by wetting them effectively.
27. Mercury does not wet glass because of larger cohesive force between Hg-Hg molecules than the adhesive forces between mercury-glass molecules.
28. When glass is heated, it melts. The surface of this liquid tends to have a minimum area. For a given volume, the surface area is minimum for a sphere. This is why the ends of a glass tube become rounded on heating.
29. The angle of contact between water and the material of the rain coat is obtuse. So the rain water does not wet the rain coat.
30. When a capillary tube of insufficient length is dipped in a liquid, the radius of curvature of the meniscus increase so that $h r = \text{constant}$. That is pressure on concave side becomes equal to pressure exerted by liquid column so liquid does not overflow.
31. No. Unless the atmospheric pressures at the two points where Bernoulli's equation is applied, are significantly different.
34. Volume and electrical resistance.
36. Gas thermometer is more sensitive as coefficient of expansion of Gas is more than mercury.
37. Expansion is always outward, therefore the hole size increased on heating.
38. Ice
39. Infinity
40. The temperature above which molar heat capacity of a solid substance becomes constant.

41. One.

42. At oK.

43. $E \propto T^4 \therefore \frac{E_2}{E_1} = \left(\frac{T_2}{T_1}\right)^4 = \left(\frac{2T_1}{T_1}\right)^4 = 16$

$\therefore E_2 = 16 E_1$

44. In conduction and radiation

45.

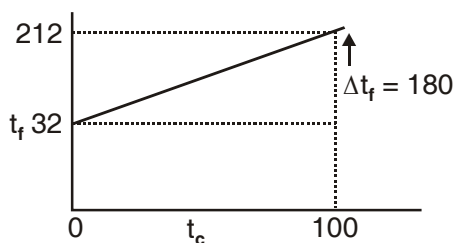

46. When birds swell their feathers, they trap air in the feather. Air being a poor conductor prevents loss of heat and keeps the bird warm.

47. The temp. coefficient of linear expansion for brass is greater than that for teel. On cooling the disc shrinks to a greater extent than the hole, and hence brass disc gets loosened.

SHORT ANSWER TYPE (2 MARKS)

2. Restoring force in extension $x = F = \frac{AYx}{L}$

Work done in stretching it by $dx = dw = F \cdot dx$

Work done in stretching it from zero to $x = W = \int dw = \int_0^x F dx$

$$W = \int_0^x \frac{AYx}{L} dx = \frac{1}{2} \frac{AYx^2}{L}$$

$$\begin{aligned}
 3. \quad \text{Energy Density} &= \frac{\text{Energy}}{\text{Volume}} = \frac{\frac{1}{2} \frac{AY}{L} x^2}{AL} \\
 &= \frac{1}{2} \left(\frac{AYx}{AL} \right) \times \frac{x}{L} \\
 &= \frac{1}{2} \frac{F}{A} \times \frac{x}{L} \\
 &= \frac{1}{2} \text{ Stress} \times \text{Strain}
 \end{aligned}$$

$$6. \quad Y_s = \frac{F}{A} \frac{l}{\Delta l_s}$$

$$Y_r = \frac{F}{A} \frac{l}{\Delta l_r}$$

For same force applied to wires made of steel & rubber of same length and same area of cross section

$$\Delta l_s < \Delta l_r$$

$$\frac{Y_s}{Y_r} = \frac{\Delta l_r}{\Delta l_s} > 1$$

$$\therefore Y_s > Y_r$$

$$7. \quad \Delta l_p = \frac{3mg}{A} \times \frac{L}{Y}$$

$$\Delta l_q = \frac{2mg}{A} \cdot \frac{2L}{Y/2} = \frac{8mg L}{A Y}$$

$$\therefore \frac{\Delta l_p}{\Delta l_q} = \frac{3}{8}$$

8. Definition of Reynold number N_R is the ratio of inertial force to viscous force.

12. Fig. (a) is correct.

At the constriction, the area of cross section is small so liquid velocity is large, consequently pressure must be small so height of liquid must be less.

13. The weight supported by (b) & (c) are same as that in (a) and is equal to 4.5×10^{-2} N.

The weight supported = $2 \sigma l$, where σ is surface tension and l is the length which is same in all the three cases, hence weight supported is same.

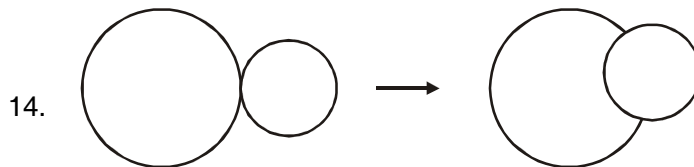

When seen from inside the smaller bubble the common surface will appear concave as (1) the pressure (excess) = $\frac{2T}{R}$ will be greater for concave surface & as R is small for the smaller bubble, the pressure will be greater.

15. $p_g = \rho g h$

$$h = \frac{P_g}{\rho g}$$

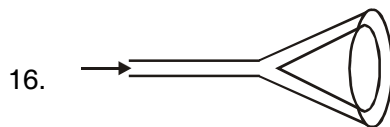

When air is blown into the narrow end its velocity in the region between filter paper and glass increases. This decreases the pressure. The filter paper gets more firmly held with the wall of the tunnel.

17. Glass transmits 50% of heat radiation coming from a hot source like sun but does not allow the radiation from moderately hot bodies to pass through it.

18. (a) Gas thermometer;
 (b) Mercury thermometer;
 (c) Platinum resistance thermometer;
 (d) Radiation pyrometer.
19. A vapour film is formed between water drop and the hot iron. Vapour being a poor conductor of heat makes the water droplet to evaporate slowly.
20. Due to green house effect, the presence of atmosphere prevents heat radiations received by earth to go back. In the absence of atmosphere radiation will go back at night making the temperature very low and inhospitable.
21. So, that it absorbs more heat with comparatively small change in temperature and extracts large amount of heat.
22. Rate of energy emission is directly proportional to area of surface for a given mass of material. Surface area of sphere is least and that of disc is largest. Therefore cooling of (i) disc is fastest and (ii) sphere is slowest.

23. (a) Time period of pendulum = $T = 2\pi\sqrt{\frac{l}{g}}$ or $T \propto \sqrt{l}$

In winter l becomes shorter so its time period reduces so it goes faster. In summer l increases resulting in increase in time period so the clock goes slower.

- (b) When the car moves down hill, the decrease in gravitational potential energy is converted into work against force of friction between brake shoe and drum which appears as heat.

24. $\lambda_m^1 < \lambda_m^3 < \lambda_m^2$

\therefore from Wein displacement law

$$T_1 > T_3 > T_2$$

25. The melting point of ice as well as the boiling point of water changes with change in pressure. The presence of impurities also changes the melting and boiling points. However the triple point of water has a unique

temperature and is independent of external factors. It is that temperatures at which water, ice & water vapour co-exist that is 273.16K and pressure 0.46 cm of Hg.

ANSWERS FOR SHORT QUESTIONS (3 MARKS)

1. The ultimate stress should not exceed elastic limit of steel ($30 \times 10^7 \text{ N/m}^2$)

$$U = \frac{F}{A} = \frac{Mg}{\pi r^2} = \frac{10^5 \times 9.8}{\pi r^2} = 30 \times 10^7$$

$$\therefore r = 3.2 \text{ cm}$$

So to lift a load of 10^4 kg , crane is designed to withstand 10^5 kg . To impart flexibility the rope is made of large number of thin wires braided.

2. Torque required to produce unit twist in hollow shaft of internal radius r_1 and external radius r_2 is

$$\tau' = \frac{\pi \eta (r_2^4 - r_1^4)}{2l}$$

$$\therefore \frac{\tau'}{\tau} = \frac{r_2^4 - r_1^4}{r^4} = \frac{(r_2^2 + r_1^2)(r_2^2 - r_1^2)}{r^4}$$

If the shafts are made of material of equal volume.

$$\pi r^2 l = \pi (r_2^2 - r_1^2) l \text{ or } r_2^2 - r_1^2 = r^2$$

$$\therefore \text{Since } r_2^2 + r_1^2 > r^2 \quad \tau' > \tau$$

3. (a) Wire with larger plastic region is more ductile material A

(b) Young's modulus is $\frac{\text{Stress}}{\text{Strain}}$

$$\therefore Y_A > Y_B$$

- (c) For given strain, larger stress is required for A than that for B.

∴ A is stronger than B.

(d) Material with smaller plastic region is more brittle, therefore B is more brittle than A.

5. (i) In case (a) Pressure head, $h = + 20$ cm of Hg

Absolute pressure = $P + h = 76 + 20 = 96$ cm of Hg.

Gauge Pressure = $h = 20$ cm of Hg.

In case (b) Pressure Head $h = -18$ cm of Hg

Absolute Pressure = $76 - 18 = 58$ cm of Hg

Gauge Pressure = $h = - 18$ cm of Hg

6. as $h, \rho, g = h_2 \rho_2 g$

$h_1 \times 13.6 \times g = 13.6 \times 1 \times g$

$$h_1 = 1 \text{ cm}$$

Therefore as 13.6 cm of H₂O is poured in right limb it will displace Hg level by 1 cm in the left limb, so that difference of levels in the two limbs will become 19 cm.

$$8. \quad v = \frac{2}{9} \left[\frac{9(\sigma - \rho)r^2}{\eta} \right]$$

$$v \times r^2$$

If N drops coalesce, then

Volume of one big drop = volume of N droplets

$$\frac{4}{3} \pi R^3 = N \left(\frac{4}{3} \pi r^3 \right)$$

$$R = N^{1/3} r \quad \dots(2)$$

$$\therefore \text{Terminal velocity of bigger drop} = \left(\frac{R}{r}\right)^2 \times v \text{ from eq.(1)}$$

$$= N^{2/3} v \text{ from eq. (2)}$$

9. Let P_1 & P_2 be the pressures inside the two bubbles then

$$P_1 - P = \frac{4T}{r_1} \Rightarrow P_1 = P + \frac{4T}{r_1}$$

$$P_2 - P = \frac{4T}{r_2} \Rightarrow P_2 = P + \frac{4T}{r_2}$$

When bubbles coalesce

$$P_1 V_1 + P_2 V_2 = PV \tag{1}$$

$$\therefore \text{The pressure inside the new bubble } p = P + \frac{4T}{r}$$

substituting for P_1 & V_1 in eq.(1)

$$\left(P + \frac{4T}{r_1}\right) \frac{4}{3} \pi r_1^3 + \left(P + \frac{4T}{r_2}\right) \frac{4}{3} \pi r_2^3 = \left(P + \frac{4T}{r}\right) \frac{4}{3} \pi r^3$$

$$\text{or } \frac{4}{3} \pi P (r_1^3 + r_2^3 - r^3) + \frac{16\pi T}{3} [r_1^2 + r_2^2 - r^2] = 0$$

Given change in volume.

$$V = \frac{4}{3} \pi r_1^3 + \frac{4}{3} \pi r_2^3 - \frac{4}{3} \pi r^3 \tag{3}$$

Change in Area

$$A = 4\pi r_1^2 + 4\pi r_2^2 - 4\pi r^2 \tag{4}$$

$$\text{Using eq. (3) \& (4) in (2) we get } PV + \frac{4T}{3} A = 0 = 3 PV + 4TA = 0$$

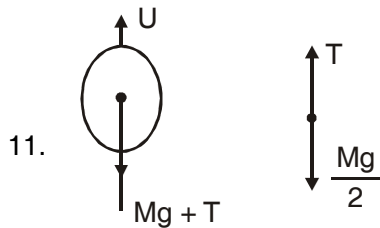

When the balloon is held stationary in air, the forces acting on it get balance

Up thrust = Wt. of Balloon + Tension in string

$$U = Mg + T$$

For the small block of mass $\frac{M}{2}$ floating stationary in air

$$T = \frac{M}{2}g$$

$$\therefore U = Mg + \frac{M}{2}g = \frac{3}{2}Mg$$

When the string is cut $T = 0$, the small block begins to fall freely, the balloon rises up with an acceleration 'a' such that

$$U - Mg = Ma$$

$$\frac{3}{2}Mg - Mg = Ma$$

$$a = \frac{g}{2} \text{ in the upward direction .}$$

12. (i) As the two vessels have liquid to same height and the vessels have same base area, the force exerted = pressure \times base area will be same as pressure = $h \rho g$.
- (ii) Since the volume of water in vessel 1 is greater than in vessel (2), the weight of water = volume \times density \times h, so weight of first vessel will be greater than the water in second vessel.

13. Radius of larger drop = $\frac{D}{2}$

radius of each small drop = r

$$\therefore 27 \times \frac{4}{3} \pi r^3 = \frac{4}{3} \pi \left(\frac{D}{2}\right)^3 \Rightarrow r = \frac{D}{6}$$

$$\text{Initial surface area of large drop } 4\pi \left(\frac{D}{2}\right)^2 = \pi D^2$$

$$\text{Final surface area of 27 small drop} = 27 \times 4\pi r^2 = 27 \times 4\pi \frac{D^2}{36} = 3\pi D^2$$

\therefore Change in energy = Increase in area $\times \sigma$

$$= 2\pi D^2 \sigma$$

16. $l_1^1 = l_1 [1 + \alpha_1 (t_2 - t_1)]$

$$l_2^1 = l_2 [1 + \alpha_2 (t_2 - t_1)]$$

Given that the difference in their length remain constant

$$\therefore l_2^1 - l_1^1 = l_2 - l_1$$

$$l_2 [1 + \alpha_2 (t_2 - t_1)] - l_1 [1 + \alpha_1 (t_2 - t_1)] = l_2 - l_1$$

$$\therefore l_2 \alpha_2 = l_1 \alpha_1$$

19. The Compressive strain $\frac{\Delta l}{l} = \alpha T = 1.2 \times 10^{-5} \times 10 = 1.2 \times 10^{-4}$

$$\begin{aligned} \text{Thermal stress} &= \frac{\Delta F}{A} = Y \frac{\Delta L}{L} = 2 \times 10^{11} \times 1.2 \times 10^{-4} \\ &= 2.4 \times 10^7 \text{ Nm}^{-2} \end{aligned}$$

which corresponds to an external force

$$\Delta F = 2.4 \times 10^7 \times 40 \times 10^{-4} = 10^5 \text{ N.}$$

A force of this magnitude can easily bend the rails, hence it is important to leave space for thermal expansion.

25. Definition of coefficient of thermal conductivity.

In steady state the heat passing in unit time through the rod remain same that is

$$\frac{Q}{t} = \frac{K_1 A (T_1 - T)}{d_1} = \frac{K_2 A (T - T_2)}{d_2} = \frac{KA (T_1 - T_2)}{d_1 + d_2}$$

where k is the coefficient of thermal conductivity

$$\text{Also } T_1 - T_2 = (T_1 - T) + (T - T_2)$$

$$\therefore \frac{d_1 + d_2}{kA} = \frac{d_1}{K_1 A} + \frac{d_2}{K_2 A}$$

$$\therefore \frac{d_1 + d_2}{K} = \frac{d_1}{K_1} + \frac{d_2}{K_2} = \frac{K_2 d_1 + K_1 d_2}{K_1 K_2}$$

$$K = \frac{K_1 K_2 (d_1 + d_2)}{K_2 d_1 + K_1 d_2}$$

ANSWER FOR NUMERICALS

$$1. \quad (a) \quad \text{Stress} = \frac{F}{A} = \frac{mg}{\pi r^2} = \frac{40 \times 10}{\pi \times (1 \times 10^{-3})^2} = 1.27 \times 10^8 \text{ N / m}^2$$

$$(b) \quad \Delta L = \frac{FL}{AY} = \frac{40 \times 10 \times 1}{\pi \times (1 \times 10^{-3})^2 \times 7 \times 10^{10}} = 1.8 \times 10^{-3} \text{ m}$$

$$(c) \text{ Strain} = \frac{\Delta L}{L} = \frac{1.8 \times 10^{-3}}{1} = 1.8 \times 10^{-3}$$

$$(d) F = Kx = K\Delta L \quad K = \text{Force constant}$$

$$K = \frac{F}{\Delta L} = \frac{40 \times 10}{1.8 \times 10^{-3}} = 2.2 \times 10^5 \text{ N / m}$$

2. Pressure exerted at the bottom layer by water column of height h is

$$\begin{aligned} P &= h\rho g = 2500 \times 1000 \times 10 \\ &= 2.5 \times 10^7 \text{ N m}^{-2} \\ &= \text{Stress} \end{aligned}$$

$$\text{Bulk modulus } K = \frac{\text{Stress}}{\text{Strain}} = \frac{P}{\Delta V / V}$$

$$\begin{aligned} \therefore \frac{\Delta V}{V} &= \frac{P}{K} = \frac{2.5 \times 10^7}{2.3 \times 10^9} = 1.08 \times 10^{-2} \\ &= 1.08\% \end{aligned}$$

3. Area A of the upper face = $(0.30)^2 \text{ m}^2$

The displacement Δx of the upper face relative to the lower one is given by

$$\begin{aligned} \Delta x &= \frac{yF}{\eta A} \quad \because \eta = \frac{F / A}{\Delta x / y} \\ &= \frac{0.30 \times 5 \times 10^3}{8.3 \times 10^{10} \times (0.30)^2} = 2 \times 10^{-7} / \text{n} \end{aligned}$$

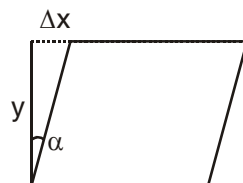

∴ Angle of shear α is given by $\tan \alpha = \frac{\Delta x}{y}$

$$\begin{aligned}\alpha &= \tan^{-1}\left(\frac{\Delta x}{y}\right) \\ &= \tan^{-1}\left(\frac{2 \times 10^{-7}}{0.30}\right) = \tan^{-1}\left(0.67 \times 10^{-6}\right)\end{aligned}$$

4. $V = 1 \text{ litre} = 10^{-3} \text{ m}^3$

$$\frac{\Delta V}{V} = 0.10\% = \frac{0.10}{100} = 0.001$$

$$K = \frac{P}{\Delta V / V} \Rightarrow P = \frac{K \Delta V}{V} = 2.2 \times 10^9 \times 0.001$$

$$P = 2.2 \times 10^6 \text{ N m}^{-2}$$

5. Pressure at a depth of 10m = $h\rho g$

$$= 10 \times 1030 \times 10 = 1.03 \times 10^5 \text{ N/m}^2$$

$$\text{ATM. pressure} = 1.01 \times 10^5 \text{ pa.}$$

$$\text{Total pressure at a depth of 10 m} = 1.03 \times 10^5 + 1.01 \times 10^5$$

$$= 2.04 \times 10^5 \text{ pa.}$$

6. $\frac{F_1}{A_1} = \frac{F_2}{A_2}$

$$F_1 = F_2 \frac{A_1}{A_2} = F_2 \left(\frac{\pi r_1^2}{\pi r_2^2} \right)$$

$$F_1 = 1350 \times 9.8 \left(\frac{5 \times 10^{-2}}{15 \times 10^{-2}} \right)^2$$

$$= 1470 \text{ N.}$$

7. (i) When man is lying $P = \frac{F}{A} = \frac{80 \times 9.8}{0.6} = 1.307 \times 10^3 \text{ N / m}^{-2}$

(ii) When man is standing then $A = 2 \times 80 \text{ cm}^2 = 160 \times 10^{-4} \text{ m}^2$

$$\therefore P = \frac{80 \times 9.8}{160 \times 10^{-4}} = 4.9 \times 10^4 \text{ N m}^{-2}$$

8. (a) Pressure Instructed by manual = $P_g = 200 \text{ k Pa}$

(b) Absolute Pressure = $101 \text{ kPa} + 200 \text{ k Pa} = 301 \text{ k Pa}$

(c) At mountain peak P_a' is 10% less

$$P_a' = 90 \text{ k Pa}$$

If we assume absolute pressure in tyre does not change during driving then $P_g = P - P_a' = 301 - 90 = 211 \text{ k Pa}$

So the tyre will read 211 k Pa, pressure.

9. Excess pressure in soap bubble = $p = \frac{4T}{r} = \left(\frac{4 \times 0.58}{6 \times 10^{-3}} \right)$
 $= 387 \text{ N m}^{-2}$

10. $v_t = \frac{2}{9} \left[\frac{g(\sigma - \rho) r^2}{\eta} \right]$

$$\eta = \frac{2}{9} \left[\frac{9.8 \left(8.9 \times 10^3 - 1.5 \times 10^3 \right) \left(2 \times 10^{-3} \right)^2}{6 \times 10^{-2}} \right]$$

$$= 1.08 \text{ kg m}^{-1} \text{ s}^{-1}$$

11. From Torricelli theorem, velocity of efflux $v = \sqrt{2gh}$

$$= \sqrt{2 \times 10 \times 0.2}$$

$$= 2 \text{ m/s}$$

12. Surface energy per unit area is equal to surface tension.

$$E = \text{increase in surface area} \times \text{ST}$$

$$= 4\pi(2^2 - 1^2) \times 2.5$$

$$= 4\pi \times 3 \times 25$$

$$= 1.02 \times 10^3 \text{ erg}$$

13. $F = \eta A \frac{dv}{dy}$

$$= 0.01 \times 0.20 \times \frac{0.1}{0.003} = 66.7 \times 10^{-3} \text{ N}$$

14. Since $A_1 v_1 = A_2 v_2$

$$v_2 = \frac{2 \times 4 \times 10^{-4}}{2 \times 10^{-4}} = 4 \text{ m / s}$$

Using Bernoulli's Theorem

$$P_2 = P_1 + \frac{1}{2} \rho (v_1^2 - v_2^2) + \rho g (h_1 - h_2)$$

$$\therefore v_2 > v_1$$

$$h_2 > h_1$$

$$= 3 \times 10^5 \frac{1}{2} (1000) [(4)^2 - (2)^2] - 1000 \times 9.8 \times 8$$

$$= 2.16 \times 10^5 \text{ N/m}^2$$

15. Shear Stress = $\frac{F}{A} = \frac{9.8 \times 10^{-2}}{0.10} = F^1$

$$\text{Strain Rate} = \frac{v}{l} = \frac{0.085}{0.30 \times 10^{-3}}$$

$$\eta = \frac{\text{Stress}}{\text{Strain}} = \frac{9.8 \times 10^{-2} \times 0.30 \times 10^{-3}}{0.085 \times 0.10}$$

$$= 3.45 \times 10^{-3} \text{ Pa s}$$

$$16. \quad \frac{\sigma_w}{\sigma_m} = \frac{h_1 \rho_1 \cos \theta_2}{h_2 \rho_2 \cos \theta_1} = \frac{10 \times 1 \times \cos 135^\circ}{-3.42 \times 13.6 \times \cos 0^\circ}$$

$$= \frac{10 \times (-0.7071)}{-3.42 \times 13.6}$$

$$= 0.152$$

17. By Wien's Displacement Law

$$\lambda_m T = \lambda_m' T'$$

$$\therefore \frac{T}{T'} = \frac{\lambda_m'}{\lambda_m} = \frac{4.8 \times 10^{-7}}{3.6 \times 10^{-7}}$$

$$= 4:3$$

$$18. \quad \frac{F - 32}{180} = \frac{T - 273}{100}$$

$$\frac{149 - 32}{180} = \frac{T - 273}{100} \Rightarrow \frac{117}{9} = T - 273$$

$$T = 286\text{k}$$

$$19. \quad m_1 c_1 (\theta_1 - \theta) = m_2 c_2 (\theta - \theta_2)$$

$$\therefore C_2 = 1 \text{ cal/gm}^\circ\text{c}$$

$$\therefore 50 \times 0.6 \times (120 - \theta) = 1.6 \times 10^3 \times 1 \times (\theta - 25)$$

$$\theta = 26.8^\circ\text{C}$$

20. $d_2 = d_1 [1 + \alpha \Delta t]$

$$5.243 = 5.231 [1 + 1.2 \times 10^{-5} (T - 300)]$$

$$\left[\frac{5243}{5231} - 1 \right] = 1.2 \times 10^{-5} (T - 300)$$

$$T = 191 + 300 = 491 \text{ K} = 218^\circ\text{C}$$

21. ice at $0^\circ\text{C} \rightarrow$ water at $0^\circ\text{C} \rightarrow$ water at 6°C

$$m_1 c_1 (80 - 6) = m_2 L + m_2 c_2 (6 - 0)$$

$$100 \times 1 \times 74 = 100 L + 100 \times 1 \times 6$$

$$L = (1 \times 74) - 6$$

$$= 68 \text{ cal/g.}$$

22. Heat required to convert H_2O at 0° to H_2O at $100^\circ = m_1 c_1 t$

$$= 3 \times 4186 \times 100$$

$$= 1255800 \text{ J}$$

Heat required to convert H_2O at 100°C to steam at 100°C is $= mL$

$$= 3 \times 2.256 \times 10^6$$

$$= 6768000 \text{ J}$$

$$\text{Total heat} = 8023800 \text{ J}$$

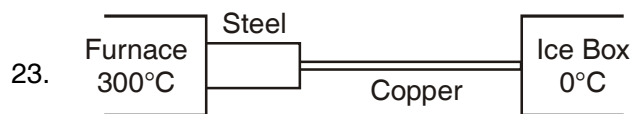

$$\frac{Q}{t} = \frac{k_1 A_1 (T_1 - T)}{d_1} = \frac{k_2 A_2 (T - T_2)}{d_2}$$

$$A_1 = 2A_2$$

$$\therefore \frac{50.2 \times 2 A_2 (573 - T)}{15 \times 10^{-2}} = \frac{385 \times A_2 (T - 273)}{10 \times 10^{-2}}$$

$$T = 317.43 \text{ k} = 44.43^\circ\text{C}$$

$$24. \quad \frac{\theta_1 - \theta_2}{t} \propto \left(\frac{\theta_1 + \theta_2}{2} \right) - \theta_0$$

$$\frac{94 - 86}{2} = k \left[\frac{94 + 86}{2} - 20 \right] \Rightarrow 4 = k \times 70 \quad \dots 1$$

$$\frac{82 - 78}{t'} = k \left[\frac{82 + 78}{2} - 20 \right] \Rightarrow \frac{4}{t'} = k60 \quad \dots 2$$

dividing eq. (1) by eq (2)

$$4 / \frac{4}{t'} = \frac{k \times 70}{k \times 60} \quad t' = \frac{7}{6} = 1.16 \text{ min}$$

$$25. \quad E = \sigma T^4$$

$$T = \left(\frac{E}{\sigma} \right)^{1/4} = \left(\frac{2.835}{5.670 \times 10^{-8}} \right)^{1/4} = 84.92 \text{ k}$$

$$= 85 \text{ k}$$

$$26. \quad R_t = R_0 (1 + \alpha \Delta t)$$

$$R_t = R_0 + 12\% \text{ of } R_0 = 1.12 R_0$$

$$1.12 R_0 = R_0 (1 + 2.5 \times 10^{-3} \Delta t)$$

$$\Delta t = \frac{0.12}{2.5 \times 10^{-3}} = 48^\circ\text{C}$$

UNIT VIII

THERMODYNAMICS

KEY CONCEPTS

- The ratio of work done (W) to the amount of heat produced (Q) is always a constant, represented by J .

$$\text{i.e., } \frac{W}{Q} = J$$

where J is called **Joule's mechanical equivalent of heat**. The value of $J = 4.186$ joule/calorie.

- If temperature of a body of mass m rises by ΔT , then $Q = mc \Delta T$ where c is *specific heat* of the material of the body,

When the state of body of mass m changes at its melting point/boiling point, then $Q = m L$, where L is *latent heat* of the body.

- All solids expand on heating. The coefficient of linear expansion (α), coefficient of superficial expansion (β) and coefficient of cubical expansion (γ) are related as

$$\alpha = \frac{\beta}{2} = \frac{\gamma}{3}.$$

- In case of liquids, $\gamma_r = \gamma_a + \gamma_c$ where γ_r is coefficient of real expansion of a liquid, γ_a is coefficient of apparent expansion of the liquid and γ_c is coefficient of cubical expansion of the vessel.
- **Principle of calorimetry** : When two substances at different temperatures are mixed together, they exchange heat. If we assume that no heat is lost to the surroundings, then according to principle of calorimetry.

$$\begin{array}{ccc} \text{Heat one} & = & \text{Heat gained} \\ \text{by on subs tan ce} & & \text{by another substance} \end{array}$$

- **Specific heat of gases** : Specific heat of a gas is the amount of heat required to raise the temperature of one gram of gas through 1°C.

Principal specific heat of a gas :

(i) Specific heat at constant volume (c_v)

(ii) Specific heat at constant pressure (c_p)

C_v → molar heat capacity at constant volume

C_p → molar heat capacity at constant pressure

$$C_p - C_v = R/J$$

- Coefficient of thermal conductivity (K) of a solid conductor is calculated from the relation

$$\frac{\Delta Q}{\Delta t} = KA \left(\frac{\Delta T}{\Delta x} \right)$$

where A is area of hot face, Δx is distance between the hot and cold faces, ΔQ is the small amount of heat conducted in a small time (Δt), ΔT is difference in temperatures of hot and cold faces.

Here $(\Delta T/\Delta x)$ *temperature gradient*, i.e., rate of *fall* of temperature with distance in the direction of flow of heat.

All liquids and gases are heated by convection. Heat comes to us from the sun by radiation.

- **Newton's Law of Cooling** : It states that the rate of loss of heat of a liquid is directly proportional to difference in temperatures of the liquid and the surroundings provided the temperature difference is small ($\approx 30^\circ\text{C}$).

$$-\frac{dQ}{dt} \propto (T - T_0) \quad \text{or} \quad \frac{dQ}{dt} = -K(T - T_0)$$

$$\text{As, } \frac{dQ}{dt} = \frac{ms dT}{dt} = -K(T - T_0) \quad \text{or} \quad \frac{dT}{dt} \propto (T - T_0).$$

- When the temperature difference between body and surroundings is large, then Stefan's law for cooling of body is obeyed. According to it,

$$E = \sigma (T^4 - T_0^4)$$

where E is the amount of thermal energy emitted per second per unit area of a black body. T is the temperature of black body and T_0 is the temperature of surroundings, σ is the Stefan's constant.

Wien's Displacement Law : The wavelength λ_{\max} at which the maximum amount of energy is radiated decreases with the increase of temperature and is such that

$$\lambda_{\max} T = a \text{ constant}$$

where T is the temperature of black body in Kelvin.

- **Thermodynamical system** : An assembly of extremely large number of gas molecules is called a thermodynamical system. The pressure P , volume V , temperature T and heat content Q are called *Thermodynamical parameters*.
- **Zerth Law of Thermodynamics** : (Concept of temperature) According to this law, when thermodynamic systems A and B are separately in thermal equilibrium with a third thermodynamic system C , then the systems A and B are in thermal equilibrium with each other also.
- **Internal Energy of a Gas** is the sum of kinetic energy and the potential energy of the molecules of the gas.

$$\text{K.E./molecule} = \frac{1}{2} mc^2 = \frac{3}{2} k T \text{ where } k \text{ is Boltzmann's constant.}$$

internal energy of an ideal gas is wholly kinetic.

- **First Law of Thermodynamics** (principle of conservation of energy)

According to this law $dQ = dU + dW$

where dQ is the small amount of heat energy exchange with a system, dU is small change in internal energy of the system and dW is the small external work done by or on the system.

- *Sign conventions* used in thermodynamics.
 - (a) Heat *absorbed* by the system = *positive* and heat rejected by the system = *negative*.
 - (b) When temperature of the system rises, its internal energy increases $\Delta U = \text{positive}$.

When temperature of the system falls, its internal energy decreases, $\Delta U = \text{negative}$.

- (c) When a gas expands, work is done by the system. It is taken as positive. When a gas is compressed, work is done *on* the system. It is taken as negative.

| Isothermal changes | Adiabatic changes |
|---|--|
| <ul style="list-style-type: none"> ● Temperature (T) remains constant, <i>i.e.</i>, $\Delta T = 0$ ● Changes are slow. ● System is thermally conducting. ● Internal energy, $U = \text{constant} \therefore \Delta U = 0$ ● Specific heat, $c = \infty$ ● Equation of isothermal changes, $PV = \text{constant}$. | <ol style="list-style-type: none"> Heat content and entropy are constant, <i>i.e.</i>, $Q = \text{const}$; $S = \text{constant}$, $\Delta Q = 0$; $\Delta S = 0$ Changes are fast. System is thermally insulated. Internal energy changes, <i>i.e.</i>, $\Delta U \neq 0$ Specific heat, $c = 0$ Eqn. of adiabatic changes (i) $PV^\gamma = \text{constant}$ (ii) $TV^{\gamma-1} = \text{constant}$ (iii) $P^{1-\gamma} T^\gamma = \text{constant}$ |
| | |
| <ul style="list-style-type: none"> ● Slope of isothermal curve, $\frac{dP}{dV} = -\left(\frac{P}{V}\right)$ ● Coeff. of isothermal elasticity, $K_i = P$ ● Work done in isothermal expansion $W = 2.303 nRT \log_{10} (V_2/V_1)$ $n \rightarrow \text{number of mole}$ $W = 2.303 P_1 V_1 \log_{10} (V_2/V_1)$ $W = 2.303 nRT \log_{10} (P_1/P_2)$ | <ol style="list-style-type: none"> Slope of adiabatic curve, $\frac{dP}{dV} = -\gamma\left(\frac{P}{V}\right)$ Coeff. of adiabatic elasticity, $K_a = \gamma P$ Work done in adiabatic expansion $W = \frac{nR(T_2 - T_1)}{1 - \gamma}$ $W = \frac{P_2 V_2 - P_1 V_1}{1 - \gamma}$ $W = C_v (T_1 - T_2)$ |

- **Second Law of Thermodynamics** : It is impossible for self acting machine, unaided by an external agency to convey heat from the body at lower temperature to another at higher temperature. This statement of the law was made by **Clausius**.

According to **Kelvin**, it is impossible to derive a continuous supply of work by cooling a body to a temperature lower than that of the coldest of its surroundings.

Heat Engines : A heat engine is a device which converts heat energy into mechanical energy. Efficiency of a heat engine is the ratio of work done (W) by the engine per cycle to the energy absorbed from the source (Q_1) per cycle.

$$\eta = \frac{W}{Q_1} = \frac{Q_1 - Q_2}{Q_1} = 1 - \frac{Q_2}{Q_1} \text{ where } Q_2 = \text{heat rejected to the sink}$$

- **Carnot Engine** : is an ideal heat engine which is based on Carnot's reversible cycle. Its working consists of four steps. (Isothermal expansion, Adiabatic expansion isothermal compression and adiabatic compression).

The efficiency of Carnot engine is given by $\eta = 1 - \frac{Q_2}{Q_1} = 1 - \frac{T_2}{T_1}$

where Q_1 is heat energy absorbed from the source maintained at high temperature T_1K and Q_2 is amount of heat energy rejected to the sink at low temperature T_2K .

A Refrigerator absorbs heat Q_2 from a sink (substance to be cooled) at lower temperature T_2K . Electric energy W has to be supplied for this purpose

$$Q_1 = Q_2 + W$$

Coefficient of performance (β) of a refrigerator is the ratio of the heat absorbed per cycle from the sink (Q_2) to the electric energy supplied (W) for this purpose per cycle, i.e.,

$$\beta = \frac{Q_2}{W}, \text{ i.e., } \beta = \frac{Q_2}{Q_1 - Q_2} = \frac{T_2}{T_1 - T_2} = \frac{1 - \eta}{\eta}$$

QUESTIONS

1. Why spark is produced when two substances are struck hard against each other?

2. What is the specific heat of a gas in an isothermal process.
3. On what factors, does the efficiency of Carnot engine depend?
4. What are two essential features of Carnot's ideal heat engine.
5. Plot a graph between internal energy U and Temperature (T) of an ideal gas.
6. Refrigerator transfers heat from cold body to a hot body. Does this violate the second law of thermodynamics.
7. What is heat pump?
8. Give two example of heat pump?
9. What is heat engine?
10. Why a gas is cooled when expanded?
11. Can the temperature of an isolated system change?
12. Which one a solid, a liquid or a gas of the same mass and at the same temperature has the greatest internal energy.
13. Under what ideal condition the efficiency of a Carnot engine be 100%.
14. Which thermodynamic variable is defined by the first law of thermodynamics?
15. Give an example where heat be added to a system without increasing its temperature.
16. What is the efficiency of carnot engine working between ice point and steam point?
17. Two blocks of the same metal having masses 5g and 10g collide against a target with the same velocity. If the total energy used in heating the balls which will attain higher temperature?
18. What is the specific heat of a gas in an adiabatic process.

SHORT ANSWER (1 MARK)

1. Work is converted into heat.

2. Infinite
3. $\eta = 1 - T_2/T_1$
4. (i) Source and sink have infinite heat capacities.
(ii) Each process of the engine's cycle is fully reversible

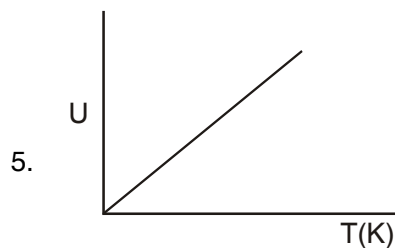

6. No, External work is done
7. A heat pump is a device which uses mechanical work to remove heat.
8. Refrigerator, Air Conditioner.
9. Heat engine is a device which convert heat energy into mechanical energy.
10. Decrease in internal energy.
11. Yes in an adiabatic process
12. Gas has greatest internal energy and solid has least internal energy.
13. If the temperature of sink is OK.
14. Internal energy.
15. Melting.
16. $\eta = 1 - T_2/T_1 = 1 - 273/373 = 26.8\%$
17. Both the balls will undergo the same rise in temperature.
18. Zero.

SHORT ANSWER TYPE QUESTION (2 MARKS)

1. A thermos bottle containing tea is vigorously shaken. What will be the effect on the temperature of tea.

- Write two limitations of the first law of thermodynamics.
- Write the expressions for C_v and C_p of a gas in terms of gas constant R and γ where

$$\gamma = C_p/C_v$$
- No real engine can have an efficiency greater than that of a Carnot engine working between the same two temperatures. Why?
- Why is water at the base of a waterfall slightly warmer than at the top?
- When ice melts, the change in internal energy is greater than the heat supplied. Why?
- Explain why two isothermal curves never intersect.
- An ideal monatomic gas is taken round the cycle ABCDA as shown. Calculate the work done during the cycle.

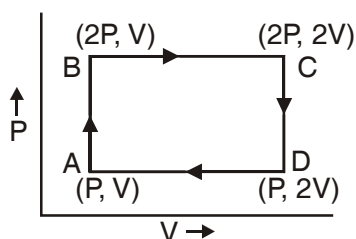

- Can a room be cooled by opening the door of a refrigerator in a closed room?
- Explain what is meant by isothermal and adiabatic operations.
- Two bodies at different temperatures T_1 and T_2 , if brought in thermal contact do not necessarily settle to the mean temperature $(T_1 + T_2)/2$. Explain?

SHORT ANSWERS (2 MARKS)

- Temperature of tea will rise.
- It does not give the direction of flow of heat.
 - It does not explain why heat cannot be spontaneously converted into work.

3. $\gamma = C_p/C_v$

$$C_p - C_v = R$$

$$C_p = \gamma C_v$$

$$(\gamma - 1)C_v = R; C_v = \frac{R}{\gamma - 1}$$

$$C_p = \frac{\gamma R}{\gamma - 1}$$

4. In carnot engine.

(i) There is absolutely no friction between the wall of cylinder and piston.

(ii) Working substance is an ideal gas

In real engine these condition cannot be fulfilled.

5. Potential energy converted in to kinetic energy, some part of kinetic energy is converted in to heat.

6. $dq = du + dw$

$$du = dq - pdv$$

When ice melt change in volume is negative.

7. PV

8. PV

9. No, It a voilets seconds law.

10. Adiabatic a Process – Pressure, volume and temperature of the system changes but there is no exchange of heat.

Isothermal Process – Pressure, volume changes temperature remain constant.

11. Heat flows from higher temperature to lower temperature until the temperature become equal only where the thermal capacities of two bodies are equal.

SHORT ANSWER TYPE QUESTIONS (3 MARKS)

1. Obtain an expression for work done in an isothermal process.
2. Identify and name the Thermodynamic processes 1,2,3 as shown in figure.

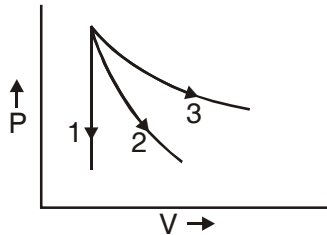

3. Two samples of gas initially at the same temperature and pressure are compressed from volume V to $V/2$ one sample is compressed isothermally and the other adiabatically in which case the pressure will be higher? Explain?
4. Explain briefly the principle of a heat pump. What is meant by coefficient of performance?
5. When you blow on the back of your hand with your mouth wide open your breath feels warm about if you partially close your mouth form an "O" and then blow on your hand breath falls cool. Why?
6. Is it a violation of the second law of thermodynamics to convert
 - (a) Work completely in to heat
 - (b) Heat completely in to workWhy or why not?
7. State first law of thermodynamics on its basis establish the relation between two molar specific heat for a gas.
8. Explain briefly the working principle of a refrigerator and obtain an expression for its coefficient of performance.
9. State zeroth law of thermodynamics. How does it lead to the concept of temperature?
10. What is a cyclic process? Show that the net work done during a cyclic process is numerically equal to the area of the loop representing the cycle.

11. State second law of thermodynamics.
12. An ideal engine works between temperatures T_1 and T_2 . It drives an ideal refrigerator that works between temperatures T_3 and T_4 . Find the ratio Q_3/Q_1 in terms of T_1, T_2, T_3 and T_4

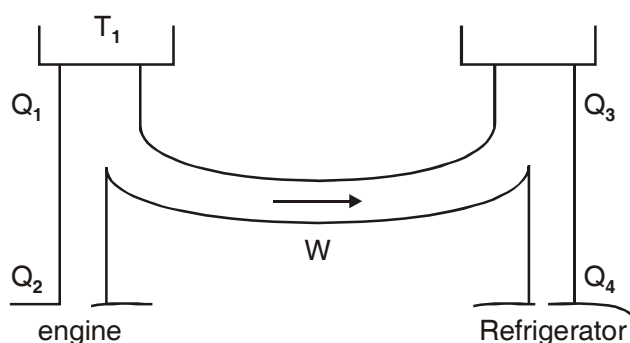

LONG ANSWER TYPE QUESTIONS (5 MARKS)

1. Describe briefly Carnot engine and obtain an expression for its efficiency.
2. Define adiabatic process. Derive an expression for work done during adiabatic process.
3. Why a gas has two principle specific heat capacities? What is the significance of $C_p - C_v$ and C_p/C_v where symbols have usual meaning.

NUMERICALS

1. When a system is taken from state A to state B along the path ACB, 80 k cal of heat flows into the system and 30 k cal of work is done.
 - (a) How much heat flows into the system along path ADB if the work done is 10 k cal?
 - (b) When the system is returned from B to A along the curved path the work done is 20 k cal. Does the system absorb or liberate heat.
 - (c) If $U_A = 0$ and $U_D = 40$ k cal, find the heat absorbed in the process AD

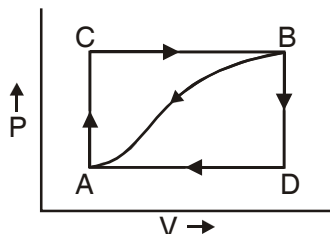

2. $\frac{1}{2}$ mole of helium is contained in a container at S.T.P. How much heat energy is needed to double the pressure of the gas, keeping the volume constant? Heat capacity of gas is $3 \text{ J g}^{-1} \text{ K}^{-1}$.
3. The volume of steam produced by 1g of water at 100°C is 1650 cm^3 . Calculate the change in internal energy during the change of state given

$$J = 4.2 \times 10^7 \text{ erg cal}^{-1} \text{ g} = 98 \text{ J cm}^3/\text{s}^2$$
 latent heat of steam = 540 cal/g
4. What is the coefficient of performance (β) of a carnot refrigerator working between 30°C and 0°C ?
5. Calculate the fall in temperature when a gas initially at 72°C is expanded suddenly to eight times its original volume. ($\gamma = 5/3$)
6. A steam engine intake steam at 200°C and after doing work exhausts it directly in air at 100°C calculate the percentage of heat used for doing work. Assume the engine to be an ideal engine?
7. A perfect carnot engine utilizes an ideal gas the source temperature is 500K and sink temperature is 375K . If the engine takes 600k cal per cycle from the source, calculate
 - (i) The efficiency of engine
 - (ii) Work done per cycle
 - (iii) Heat rejected to sink per cycle.
8. Two carnot engines A and B are operated in series. The first one A receives heat at 900 K and reject to a reservoir at temperature $T \text{ K}$. The second engine B receives the heat rejected by the first engine and in turn rejects to a heat reservoir at 400 K calculate the temperature T when
 - (i) The efficiencies of the two engines are equal
 - (ii) The work output of the two engines are equal

9. Ten mole of hydrogen at NTP is compressed adiabatically so that its temperature become 400°C How much work is done on the gas? what is the increase in the internal energy of the gas

$$R = 8.4 \text{ J mol}^{-1}\text{K}^{-1} \quad \gamma = 1.4$$

10. The temperature T_1 and T_2 of the two heat reservoirs in an ideal carnot engine be 1500°C and 500°C respectively. which of these increasing T_1 by 100°C or decreasing T_2 by 100°C would result in a greater improvement in the efficiency of the engine.

ANSWERS

1. (a) $dw_{ADB} = +10 \text{ k cal}$

Internal energy is path independent

$$du_{ADB} = du_{ACB} = 50 \text{ k cal}$$

$$dQ_{ADB} = 50 + 10 = 60 \text{ k cal.}$$

(b) $dw_{BA} = -20 \text{ k cal}$

$$du_{BA} = -du_{ADB}$$

$$dQ_{BA} = du_{BA} + dW_{BA}$$

$$= -50 - 20 = -70 \text{ k cal}$$

(c) $U_A = 0 \quad U_D = 40 \text{ k cal}$

$$du_{AD} = 40 \text{ k cal}$$

$$dw_{ADB} = 10 \text{ k cal}$$

$$dw_{DB} = 0 \text{ since } dV = 0$$

$$dQ_{AD} = 40 + 10 = 50 \text{ k cal}$$

2. $n = \frac{1}{2}, C_v = 3\text{J/gK. } M = 4$

$$C_v = MC_v = 12 \text{ J/mole k} \quad M \rightarrow \text{Molecular mass}$$

$$\frac{P_2}{P_1} = \frac{T_2}{T_1} = 2$$

$$\Delta T = 2T_1 - T_1 = 273 \text{ K}$$

$$\Delta Q = n c_v \Delta T = 1638 \text{ J}$$

3. Mass of water = 1 g = 10^{-3} kg

$$\begin{aligned} \text{volume of water} &= \frac{\text{Mass}}{\text{Density}} = \frac{10^{-3}}{10^3} = 10^{-6} \text{ m}^3 \\ &= 1 \text{ cm}^3 \end{aligned}$$

$$\text{Change in volume} = 1650 - 1 = 1649 \text{ cm}^3$$

$$dQ = m L = 540 \text{ cal} = 540 \times 4.2 \times 10^7 \text{ erg}$$

$$P = 1 \text{ atm} = 76 \times 13.6 \times 981$$

$$\begin{aligned} du &= dQ - pdv = 22.68 \times 10^9 - 1.67 \times 10^9 \\ &= 21.01 \times 10^9 \text{ erg.} \end{aligned}$$

4. $\beta = \frac{T_2}{T_1 - T_2} = \frac{273}{303 - 273} = 9.1$

5. $T_1 V_1^{v-1} = T_2 V_2^{v-1}$

$$\begin{aligned} T_2 &= T_1 \left(\frac{V_1}{V_2} \right)^{v-1} = 345 \left(\frac{x}{8x} \right)^{2/3} \\ &= 345 \times \frac{1}{4} = 86.25 \text{ K} \end{aligned}$$

6. $T_1 = 200^\circ\text{C} = 473 \text{ K}$ $T_2 = 100^\circ\text{C} = 373 \text{ K}$

$$\begin{aligned} \eta &= \frac{w}{Q_1} = \frac{T_1 - T_2}{T_1} = \frac{473 - 373}{473} \\ &= \frac{100}{473} = 0.21 \\ &= 21\% \end{aligned}$$

7. $T_1 = 500 \text{ K}$ $T_2 = 375 \text{ K}$

$$Q_1 = \text{Heat absorbed} = 600 \text{ k cal}$$

$$\eta = 1 - T_2/T_1 = \frac{125}{500} = 0.25$$

$$= 25\%$$

$$(b) \quad \eta = \frac{W}{Q_1}$$

$$W = \eta Q_1 = 0.25 \times 60 \text{ k cal} = 150 \text{ k cal}$$

$$= 450 \text{ k cal}$$

$$(c) \quad w = Q_1 - Q_2 \quad Q_2 = Q_1 - W = 600 - 150$$

$$= 450 \text{ k cal}$$

$$8. \quad W_A = W_B$$

$$\frac{W}{Q_1} = \left(1 - \frac{T_2}{T_1}\right)$$

$$W = Q_1(1 - T_2/T_1)$$

$$Q_2(1 - T_3/T_2) = Q_1(1 - T_2/T_1)$$

$$(1 - T/900) \quad Q_1 = \left(1 - \frac{400}{T}\right) Q_2$$

$$(1 - T/900) \quad Q_1 = \left(1 - \frac{400}{T}\right) T/900$$

$$1 - T/900 = \frac{T}{900} - \frac{400}{900}$$

$$\frac{2T}{900} = 13/9$$

$$T = 650 \text{ K}$$

$$\eta_A = \eta_B$$

$$1 - T/900 = \frac{1 - 400}{T}$$

$$T^2 = 900 \times 400$$

$$= 600 \text{ k}$$

$$T_1 = 273 \text{ k } T_2 = 673 \text{ k}$$

mass of gas = 10 mole

$$\text{wadi} = \frac{10 R}{(\gamma - 1)} (T_1 - T_2)$$

$$= \frac{10 \times 8.4}{(1.4 - 1)} (273 - 673)$$

$$= -8.4 \times 10^4 \text{ J work being done on the gas}$$

$$du = -dw = 8.4 \times 10^4 \text{ J}$$

10. $\eta = 1 - T_2/T_1$

(i) T_1 is increased from 1500°C to 1600°C

$$T_1 = 1873 \text{ k}$$

$$T_2 \text{ remain constant } T_2 = 773 \text{ k}$$

$$\eta_1 = \frac{1873 - 773}{1873} = 58.73\%$$

(ii) T_1 remain constant 1500°C

$$T_1 = 1500 + 273 = 1773 \text{ k}$$

$$T_2 \text{ is decreased by } 100 \text{ i.e. } 400^\circ\text{C}$$

$$T_2 = 400 + 273 = 673 \text{ k}$$

$$\eta_2 = \frac{1773 - 673}{1773} = \frac{1100}{1773} = 62.04\%$$

$$\eta_2 > \eta_1$$

UNIT IX

BEHAVIOUR OF PERFECT GAS AND KINETIC THEORY

POINTS TO REMEMBER

- **Pressure exerted by a gas** : It is due to continuous collision of gas molecules against the walls of the container and is given by the relation

$$P = \frac{Mc^2}{3V} = \frac{1}{\rho} \rho c^2 \text{ where } c \text{ is the rms velocity of gas molecules.}$$

- **Average K.E. per molecule** of a gas $\frac{1}{2}mC^2 = \frac{3}{2}k_B T$. It is independent of the mass of the gas but depends upon the temperature of the gas.
- **Absolute zero** : It is that temperature at which the root mean square velocity of the gas molecules reduces to zero.
- **Different types of speed of gas molecules**

(i) Most probable speed $c_{mp} = \sqrt{\frac{2k_B T}{m}}$

$k_B \rightarrow$ Boltzmann's Constant

- (ii) **Mean speed** or average speed

$$c_{av} = \frac{c_1 + c_2 + \dots + c_n}{n} = \sqrt{\frac{8k_B T}{m\pi}}$$

- (iii) The number of degrees of freedom = total number of independent co-ordinates required to describe completely, the position and configuration of the system.

For monoatomic gases, $f = 3$

For diatomic gases, $f = 5$

For linear triatomic gas molecules, $f = 7$

For non-linear triatomic gas molecules, $f = 6$

- According to the **law of equipartition of energy**, for any dynamical system in thermal equilibrium, the total energy is distributed equally amongst all the degrees of freedom. The average energy associated with each molecule per degree of freedom = $\frac{1}{2} k_B T$, where k_B is Boltzmann constant and T is temperature of the system.
- **Mean free path** of gas molecules is the average distance travelled by a molecule between two successive collisions. It is represented by λ .

$$\lambda = \frac{1}{\sqrt{2}\pi d^2 n}$$

where d = diameter of molecule and n = number of molecules per unit volume of the gas.

$$\text{also } \lambda = \frac{k_B T}{\sqrt{2}\pi d^2 p}$$

where k_B is Boltzmann constant; p is pressure and T is temperature of the gas.

VERY SHORT ANSWER TYPE QUESTIONS (1 MARK)

1. Write two condition when real gases obey the ideal gas equation ($PV = nRT$). $n \rightarrow$ number of mole.
2. If the number of molecule in a container is doubled. What will be the effect on the *rms* speed of the molecules?
3. Draw the graph between P and $1/V$ (reciprocal of volume) for a perfect gas at constant temperature.
4. Name the factors on which the degree of freedom of gas depends.
5. What is the volume of a gas at absolute zero of temperature?
6. How much volume does one mole of a gas occupy at NTP?

7. What is an ideal gas?
8. The absolute temperature of a gas is increased 3 times what is the effect on the root mean square velocity of the molecules?
9. What is the Kinetic Energy per unit volume of a gas whose pressure is P ?
10. A container has equal number of molecules of hydrogen and carbon dioxide. If a fine hole is made in the container, then which of the two gases shall leak out rapidly?
11. What is the mean translational Kinetic energy of a perfect gas molecule at temperature T ?
12. Why it is not possible to increase the temperature of a gas while keeping its volume and pressure constant.

SHORT ANSWER TYPE QUESTIONS (2 MARKS)

1. When an automobile travels for a long distance the air pressure in the tyres increases. Why?
2. A gas storage tank has a small leak. The pressure in the tank drop more quickly if the gas is hydrogen than if it is oxygen. Why?
3. Why the land has a higher temperature than the ocean during the day but a lower temperature at night.
4. Helium is a mixture of two isotopes having atomic masses 3g/mol and 4g/mol. In a sample of helium gas, which atoms move faster on average?
5. State Avogadro's law. Deduce it on the basis of Kinetic theory of gases.
6. Although the velocity of air molecules is nearly 0.5 km/s yet the smell of scent spreads at a much slower rate why.
7. The root mean square (rms) speed of oxygen molecule at certain temperature ' T ' is ' V '. If temperature is doubled and oxygen gas dissociates into atomic oxygen what is the speed of atomic oxygen?
8. Two vessels of the same volume are filled with the same gas at the same temperature. If the pressure of the gas in these vessels be in the ratio 1 : 2 then state
 - (i) The ratio of the rms speeds of the molecules.

(ii) The ratio of the number of molecules.

- Why gases at high pressure and low temperature show large deviation from ideal gas behaviour.
- A gas is filled in a cylinder fitted with a piston at a definite temperature and pressure. Why the pressure of the gas decreases when the piston is pulled out.

SHORT ANSWER TYPE QUESTIONS (3 MARKS)

- On what parameters does the λ (mean free path) depends.
- Equal masses of oxygen and helium gases are supplied equal amount of heat. Which gas will undergo a greater temperature rise and why?
- Why evaporation causes cooling?
- Two thermally insulated vessels 1 and 2 are filled, with air at temperatures (T_1, T_2), volume (V_1, V_2) at pressure (P_1, P_2) respectively. If the valve joining the two vessels is opened what is temperature of the vessel at equilibrium.
- A partition divides a container having insulated walls into two compartments I and II. The same gas fills the two compartment. What is the ratio of the number of molecules in compartments I and II?

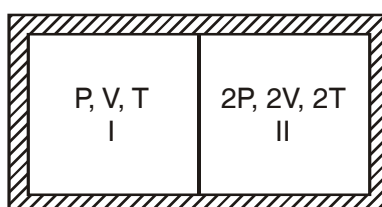

- Prove that for a perfect gas having n degree of freedom

$$\frac{C_p}{C_v} = 1 + \frac{2}{n}$$

where C_p and C_v have their usual meaning.

- The ratio of specific heat capacity at constant pressure to the specific heat capacity at constant volume of a diatomic gas decreases with increase in temperature. Explain.

8. Isothermal curves for a given mass of gas are shown at two different temperatures T_1 and T_2 state whether $T_1 > T_2$ or $T_2 > T_1$, justify your answer.

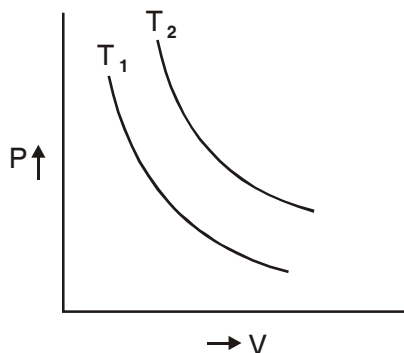

9. Three vessels of equal capacity have gases at the same temperature and pressure. The first vessel contains neon (monatomic) the second contains chlorine (diatomic) and the third contains uranium hexafluoride (polyatomic). Do the vessels contain equal number of respective molecules? Is the root mean square speed of molecules the same in the three cases? If not in which case is V_{rms} the largest?
10. State Graham's law of diffusion. How do you obtain this from Kinetic Theory of gases.

LONG ANSWER TYPE QUESTIONS (5 MARKS)

1. Prove that the pressure exerted by a gas is given by

$$P = \frac{1}{3} \rho c^2$$

where p is density and c is root mean square velocity.

2. What are the fundamental postulates of the Kinetic theory of gases?
3. Given that $P = \frac{1}{3} \rho c^2$ where P is the pressure, ρ is the density and c is the rms. Velocity of gas molecules. Deduce Boyle's law and Charles law of gases from it.
4. What do you understand by mean speed, root mean square speed and most probable speed of a gas. The velocities of ten particles in m/s are 0, 2, 3, 4, 4, 4, 5, 5, 6, 9 calculate.
- (i) Average speed (ii) r.m.s. speed

5. What is law of equipartition of energy? Find the value of $\gamma = C_p/C_v$ for diatomic and monatomic gas. Where symbol have usual meaning.

NUMERICALS

1. An air bubble of volume 1.0 cm^3 rises from the bottom of a lake 40 m deep at a temperature of 12°C . To what volume does it grow when it reaches the surface which is at a temperature of 35°C ?
2. An electric bulb of volume 250 cm^3 was sealed off during manufacture at a pressure of 10^{-3} mm of Hg at 27°C . Find the number of air molecules in the bulb–

$$(R = 8.31 \text{ J mole}^{-1} \text{ K}^{-1}, N_A = 6.02 \times 10^{23} \text{ mole}^{-1})$$

$$(\text{density of mercury } \rho = 13.6 \times 10^3 \text{ kg m}^{-3})$$

3. An ideal gas has a specific heat at constant pressure ($C_p = 5 R/2$). The gas is kept in a closed vessel of volume 0.0083 m^3 at a temperature of 300 K and a pressure of $1.6 \times 10^6 \text{ Nm}^{-2}$. An amount of $2.49 \times 10^4 \text{ J}$ of heat energy is supplied to the gas. Calculate the final temperature and pressure of the gas

$$(R = 8.3 \text{ J K}^{-1} \text{ mol}^{-1})$$

4. An oxygen cylinder of volume 30 litre has an initial gauge pressure of 15 atmosphere and a temperature of 27°C . After some oxygen is withdrawn from the cylinder, the gauge pressure drops to 11 atmosphere and its temperature drop to 17°C . Estimate the mass of oxygen taken out of the cylinder

$$(R = 8.31 \text{ J mol}^{-1} \text{ K}^{-1})$$

$$(\text{molecular mass of } \text{O}_2 = 32)$$

5. At what temperature the rms speed of oxygen atom equal to r.m.s. speed of heliums gas atom at -10°C

$$\text{Atomic mass of helium} = 4$$

$$\text{Atomic mass of oxygen} = 32$$

6. The density of Carbon dioxide gas at 0°C and at a pressure of $1.0 \times 10^5 \text{ newton/m}^2$ is 1.98 kg/m^3 . Find the root mean square velocity of its molecules at 0°C and 30°C . Pressure is kept constant.

7. 0.014 kg of nitrogen is enclosed in a vessel at a temperature of 27°C. How much heat has to be transferred to the gas to double the rms speed of its molecules.

ANSWERS (1 MARK)

1. (i) Low pressure (ii) High temperature
2. No effect

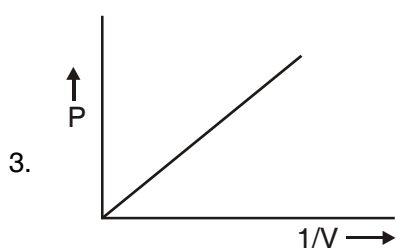

4. Atomicity and temperature
5. 0
6. 22.4 litre
7. Gas in which intermolecular forces are absent
8. increases $\sqrt{3}$ times
9. $3P/2$
10. Hydrogen (rms speed is greater)
11. $\frac{3}{2} RT$
12. $P = \frac{1}{3} \frac{M}{V} K T$ $T \propto (PV)$

P and V are constant then T is also constant.

ANSWERS (2 MARKS)

1. Work is done against friction. This work done is converted into heat.

2. Rate of diffusion of a gas is inversely proportional to the square root of the density. So hydrogen leaked out more rapidly.
3. Specific Heat of water is more than land (earth). Therefore for given heat change in temp. of land is more than ocean (water).
6. The air molecules travel along a zigzag path due to frequent collision as a result their displacement per unit time is very small.

$$7. \quad C = \sqrt{\frac{3RT}{M}} = v \qquad C' = \sqrt{\frac{3R(2T)}{M/2}} = \sqrt{\frac{3RT}{M}}$$

$$C' = 2V$$

$$8. \quad P = \frac{1}{3} \frac{m n c^2}{V} \qquad P \propto n c^2 ; \quad c \propto \sqrt{T}$$

as the temperature is same rms speeds are same.

$$P_1 n_1 = P_2 n_2 \quad \text{i.e.} \quad \frac{P_1}{P_2} = \frac{n_1}{n_2} = \frac{1}{2}$$

9. When temp is low and pressure is high the intermolecular forces become appreciable thus the volume occupied by the molecular is not negligibly small as compared to volume of gas.
10. When piston is pulled out the volume of the gas increases, Now losses number of molecules colliding against the wall of container per unit area decreases. Hence pressure decreases.

ANSWERS (3 MARKS)

1. (i) diameter of molecule (iii) $\gamma \propto \frac{1}{P}$
2. (ii) $\lambda \propto T$ (iv) $\lambda \propto \frac{1}{f}$ (v) $\lambda \propto \frac{1}{n}$ (vi) $\lambda \propto m$
3. During evaporation fast moving molecules escape a liquid surface so the average kinetic energy of the molecules left behind is decreased thus the temperature of the liquid is lowered.
4. number of mole = Constant

$$\mu_1 + \mu_2 = \mu$$

$$\frac{P_1 V_1}{R T_1} + \frac{P_2 V_2}{R T_2} = \frac{P(V_1 + V_2)}{R T}$$

from Boyles law $P(V_1 + V_2) = P_1 V_1 + P_2 V_2$

$$5. \quad n = \frac{pV}{kT} \quad h' = \frac{2p \cdot 2v}{kT}$$

$$n / n' = \frac{1}{4}$$

$$8. \quad T = \frac{PV}{\mu R} \quad T \propto P V \text{ (man is constant)} (\mu \text{ is constant})$$

since PV is greater for the curve at T_2 than for the curve T_1 therefore $T_2 > T_1$

Three vessels at the same pressure and temperature have same volume and contain equal number of molecules

$$V_{rms} = \sqrt{\frac{3RT}{m}} \quad V_{rms} \propto \frac{1}{\sqrt{m}}$$

rms speed will not same, neon has smallest mass therefore rms speed will be largest for neon.

ANSWERS NUMERICALS

$$1. \quad v_1 = 10^{-6} \text{m}^3$$

Pressure on bubble $P_1 = \text{water pressure} + \text{Atmospheric pressure}$

$$= \rho gh + P_{atm}$$

$$= 4.93 \times 10^5 \text{ Pa}$$

$$T_1 = 285 \text{ k. } T_2 = 308 \text{ k}$$

$$\frac{P_1 V_1}{T_1} = \frac{P_2 V_2}{T_2}$$

$$V_2 = \frac{4.93 \times 10^5 \times 1 \times 10^{-6} \times 308}{285 \times 1.01 \times 10^5} = 5.3 \times 10^{-6} \text{ m}^3$$

2. $V = 250 \text{ cc} = 250 \times 10^{-6} \text{ m}^3$

$$P = 10^{-6} \text{ m } \rho = 13.6 \times 10^3 \text{ kg/m}^3$$

$$T = 300 \text{ K}$$

$$\mu = \frac{PV}{RT} = \frac{h\rho gV}{RT} = 1.3 \times 10^{-8} \text{ mole}$$

$$\text{number of molecule} = \mu N_A = 8 \times 10^{15}$$

3. $PV = nRT \Rightarrow n = \frac{PV}{RT}$

$$n \rightarrow \text{number of mole of gas} = \frac{1.6 \times 10^6 \times .0083}{8.314 \times 300}$$

$$\approx 4$$

Heat has been supplied at constant volume

$$\therefore \Delta Q_V = nC_V \Delta T \text{ When } C_V = C_P - R$$

$$= \frac{5}{2}R - R = \frac{3}{2}R$$

$$2.49 \times 10^6 = 4 \times \frac{3}{2} \times 8.3 (T' - 300) \quad \Delta T = T' - 300$$

$$\Rightarrow T' = 800 \text{ K } T' \rightarrow \text{final temperature}$$

If P' be the final pressure then

$$P'V = nRT'$$

$$P' = \frac{nRT'}{V} = \frac{4 \times 8.3 \times 800}{.0083}$$

$$= 4 \times 8 \times 10^5 = 3.2 \times 10^6 \text{ N/m}^2$$

$$4. \quad V_1 = 30 \text{ litre} = 30 \times 10^3 \text{ cm}^3 = 3 \times 10^{-2} \text{ m}^3$$

$$P_1 = 15 \times 1.013 \times 10^5 \text{ N/m}^2$$

$$T_1 = 300 \text{ K}$$

$$\mu_1 = \frac{P_1 V_1}{RT_1} = 18.3$$

$$\mu_2 = \frac{P_2 V_2}{RT_2}$$

$$P_2 = 11 \times 1.013 \times 10^5 \text{ N/m}^2$$

$$V_2 = 3 \times 10^{-2} \text{ m}^3$$

$$T_2 = 290 \text{ K}$$

$$\mu_2 = 13.9$$

$$= 18.3 - 13.9 = 4.4$$

$$\text{Mass of gas taken out of cylinder} = 4.4 \times 32 \text{ g}$$

$$= 140.8 \text{ g}$$

$$= 0.140 \text{ kg.}$$

$$5. \quad V_{\text{rms}} = \left[\frac{3PV}{M} \right]^{1/2} = \left[\frac{3RT}{M} \right]^{1/2}$$

Let r.m.s speed of oxygen is $(V_{\text{rms}})_1$ and of helium is $(V_{\text{rms}})_2$ is equal at temperature T_1 and T_2 respectively.

$$\frac{(V_{\text{rms}})_1}{(V_{\text{rms}})_2} = \sqrt{\frac{M_2 T_1}{M_1 T_2}}$$

$$\left[\frac{4T_1}{32 \times 263} \right]^{1/2} = 1$$

$$T_1 = \frac{32 \times 263}{4} = 2104 \text{ K}$$

$$6. \quad P = \frac{1}{3} \rho v^2$$

$$V_{rms} = \sqrt{\overline{v^2}} = \sqrt{\frac{3P}{\rho}}$$

$$V_{rms} = \sqrt{\frac{3 \times 1 \times 10^5}{1.98}} = 389 \text{ m/sec}$$

$$V_{rms} \propto \sqrt{T}$$

$$\frac{(V_{rms})_{20}}{(V_{rms})_0} = \sqrt{\frac{273 + 30}{273}} = \sqrt{\frac{303}{273}} = 1.053$$

$$(V_{rms})_{30} = 389 \times 1.053 = 410 \text{ m/s}$$

7. Number of mole in 0.014 kg of Nitrogen.

$$n = \frac{0.014 \times 10^3}{28} = \frac{1}{2} \text{ mole}$$

$$C_V = \frac{5}{2}R = \frac{5}{2} \times 2 = 5 \text{ cal / mole k}$$

$$\frac{v_2}{v_1} = \sqrt{\frac{T_2}{T_1}} \quad T_2 = 4T_1$$

$$\begin{aligned} \Delta T &= T_2 - T_1 = 4T_1 - T_1 = 3T_1 \\ &= 3 \times 300 = 900 \text{ K} \end{aligned}$$

$$\Delta Q = n c_v \Delta T = \frac{1}{2} \times 5 \times 900 = 2250 \text{ cal}$$

UNIT X

OSCILLATIONS AND WAVES

- **Periodic Motion** : It is that motion which is identically repeated after a fixed interval of time. The fixed interval of time after which the motion is repeated is called period of motion.

For example, the revolution of earth around the sun

- **Oscillatory Motion or Vibratory Motion** : It is that motion in which a body moves to and fro or back and forth repeatedly about a fixed point (called mean position), in a definite interval of time.
- **Simple Harmonic Motion** : It is a special type of periodic motion, in which a particle moves to and fro repeatedly about a mean (*i.e.*, equilibrium) position and the magnitude of force acting on the particle at any instant is directly proportional to the displacement of the particle from the mean (*i.e.*, equilibrium) position at that instant *i.e.* $F = -k y$.

where k is known as force constant. Here, $-ve$ sign shows that the restoring force (F) is always directed towards the mean position.

- **Displacement in S.H.M** : The displacement of a particle executing S.H.M at an instant is defined as the distance of the particle from the mean position at that instant. It can be given by the relation

$$y = a \sin \omega t \text{ or } y = a \cos \omega t$$

The first relation is valid when the time is measured from the mean position and the second relation is valid when the time is measured from the extreme position of the particle executing S.H.M.

- **Velocity in S.H.M** : It is defined as the time rate of change of the displacement of the particle at the given instant. Velocity in S.H.M. is given by

$$V = \frac{dy}{dt} = \frac{d}{dt}(a \sin \omega t) = a\omega \cos \omega t = a\omega \sqrt{1 - \sin^2 \omega t} = a\omega \sqrt{1 - y^2/a^2}$$

$$= \omega \sqrt{a^2 - y^2}$$

- **Acceleration in S.H.M** : It is defined as the time rate of change of the velocity of the particle at the given instant, *i.e.*,

$$a = \frac{dv}{dt}$$

$$\frac{d}{dt} a \omega \cos \omega t = -\omega^2 a \sin \omega t = -\omega^2 y$$

- **Time period in S.H.M** is given by

$$T = 2\pi \sqrt{\frac{\text{displacement}}{\text{acceleration}}}, \quad \text{or} \quad T = 2\pi \sqrt{\frac{\text{inertia factor}}{\text{spring factor}}}$$

- **Frequency of vibration in S.H.M.**,

$$\gamma = \frac{1}{T} = \frac{1}{2\pi} \sqrt{\frac{\text{acceleration}}{\text{displacement}}}, \quad \text{or} \quad \nu = \frac{1}{2\pi} \sqrt{\frac{\text{spring factor}}{\text{inertia factor}}}$$

- **Total energy in S.H.M**

$$= \text{P.E.} + \text{K.E.} = \frac{1}{2} m \omega^2 y^2 + \frac{1}{2} m \omega^2 (a^2 - y^2) = \frac{1}{2} m \omega^2 a^2 = \text{a constant.}$$

- **Expression for time period**

(i) in case of simple pendulum $T = 2\pi \sqrt{\ell/g}$

(iv) Oscillations of a loaded spring $T = 2\pi \sqrt{m/k}$

where, m is the mass of body attached at the free end of spring and K is the force constant of spring.

- **Spring constant (K) of a spring** : It is defined as the force per unit extension or compression of the spring.

- (i) The spring constant of the combination of two springs in series is

$$K = \frac{k_1 k_2}{k_1 + k_2}$$

- (ii) The spring constant of the combination of two springs in parallel's

$$K = k_1 + k_2$$

- **Undamped oscillations** : When a simple harmonic system oscillates with a constant amplitude (which does not change) with time, its oscillations are called undamped oscillations.
- **Damped oscillations** : When a simple harmonic system oscillates with a decreasing amplitude with time, its oscillations are called damped oscillations.
- **Free, forced and resonant oscillations**
 - (a) **Free oscillations** : When a system oscillates with its own natural frequency without the help of an external periodic force, its oscillations are called free oscillations.
 - (b) **Forced oscillations** : When a system oscillates with the help of an external periodic force of frequency, other than its own natural frequency, its oscillations are called forced oscillations.
 - (c) **Resonant oscillations** : When a body oscillates with its own natural frequency, with the help of an external periodic force whose frequency is the same as that of the natural frequency of the oscillating body, then the oscillations of the body are called resonant oscillations.
- **A Wave Motion** is a form of disturbance which travels through a medium on account of repeated periodic vibrations of the particles of the medium about their mean position, the motion being handed on from one particle to the adjoining particle.

A material medium is a must for propagation of waves. It should possess the properties of inertia, and elasticity. The two types of wave motion are :

- (i) **Transverse wave** motion that travels in the form of crests and troughs.
 - (ii) **Longitudinal wave** motion that travels in the form of compressions and rarefactions.
- **Speed of longitudinal waves** in a long solid rod is $v = \sqrt{Y/\rho}$

where, Y is Young's modulus of the material of solid rod and ρ is density of the material. The speed of longitudinal waves in a *liquid* is given by $v = \sqrt{K/\rho}$, where K is *bulk modulus of elasticity* of the liquid.

- The expression for speed of longitudinal waves in a gas, as suggested by **Newton and modified late by Laplace is**

$$v = \sqrt{\frac{\gamma P}{\rho}} \quad \text{where} \quad \gamma = C_p/C_v$$

P is pressure exerted by the gas.

- **The speed of transverse waves** over a string is given by $v = \sqrt{T/m}$ where, T is *tension* in the string and m is mass of unit length of the string.
- **Equation of plane progressive waves** travelling with a velocity v along positive direction of X-axis is

$$y = a \sin \frac{2\pi}{\lambda} (vt - x)$$

where, λ is wavelength of the wave, a is amplitude of particle, and x is the distance from the origin.

- **Superposition principle** enables us to find the resultant of any number of waves meeting at a point. If $\vec{y}_1, \vec{y}_2, \vec{y}_3, \dots, \vec{y}_n$ are displacements at a point due to n waves, the resultant displacement \vec{y} at that point is given by $\vec{y} = \vec{y}_1 + \vec{y}_2 + \dots + \vec{y}_n$
- **On a string, transverse stationary waves** are formed due to superimposition of direct and the reflected transverse waves.
- The wavelength of n^{th} mode of vibration of a stretched string is

$$\lambda_n = \frac{2L}{n} \quad \text{and its frequency, } v_n = n v_1$$

This note is called n^{th} harmonic or $(n - 1)$ th overtone.

- **Nodes are the points**, where amplitude of vibration is zero, In the n^{th} mode of vibration, there are $(n + 1)$ nodes located at distances (from one end)

$$x = 0, \frac{L}{n}, \frac{2L}{n}, \dots, L$$

Antinodes are the points, where amplitude of vibration is *maximum*. In the n^{th} mode of vibration, there are n antinodes, located at distances (from one end)

$$x = \frac{L}{2n}, \frac{3L}{2n}, \frac{5L}{2n}, \dots, \frac{(2n-1)L}{2n}$$

- **In an organ pipe closed at one end**, longitudinal stationary waves are formed.

frequency of n^{th} mode of vibration, $v_n = (2n-1)v_1$

- **In an organ pipe open at both ends**, antinodes are formed at the two ends, separated by a node in the middle in the first normal mode of vibration and so on. The fundamental frequency in this case is twice the fundamental frequency in a closed organ pipe of same length.

In an open organ pipe, all harmonics are present, whereas in a closed organ pipe, even harmonics are missing.

- **Beats** : Beats is the phenomenon of regular variation in the intensity of sound with time when two sources of nearly equal frequencies are sounded together.
- If v_1 and v_2 are the frequencies of two sources producing beats, then time

interval between two successive maxima = $\frac{1}{v_1 - v_2}$

time interval between two successive minima = $\frac{1}{v_1 - v_2}$

$$F_1 = F_2 \frac{A_1}{A_2} = F_2 \left(\frac{\pi r_1^2}{\pi r_2^2} \right)$$

Doppler's Effect : Whenever there is a relative motion between a source of sound and listener, the apparent frequency of sound heard is different from the actual frequency of sound emitted by the source.

If γ is actual frequency of sound emitted and v' , the apparent frequency,

then $v' = \frac{(v + v_L)}{(v - v_s)} v$

where, v is velocity of sound in air v_s is velocity of source (S) and v_L is velocity of listener (L), both moving along SL. Note that velocity along SL is taken positive and velocity along LS is taken negative.

ONE MARK QUESTIONS

1. How is the time period effected, if the amplitude of a simple pendulum is increased?
2. Define force constant of a spring.
3. At what distance from the mean position, is the kinetic energy in simple harmonic oscillator equal to potential energy?
4. How is the frequency of oscillation related with the frequency of change in the of K.E and P.E of the body in S.H.M.?
5. What is the frequency of total energy of a particle in S.H.M.?
6. How is the length of seconds pendulum related with acceleration due gravity of any planet?
7. If the bob of a simple pendulum is made to oscillate in some fluid of density greater than the density of air (density of the bob density of the fluid), then time period of the pendulum increased or decrease.
8. How is the time period of the pendulum effected when pendulum is taken to hills or in mines?
9. A transverse wave travels along x-axis. The particles of the medium must move in which direction?
10. Define angular frequency. Give its S.I. unit.
11. Sound waves from a point source are propagating in all directions. What will be the ratio of amplitudes at distances of x meter and y meter from the source?
12. Does the direction of acceleration at various points during the oscillation of a simple pendulum remain towards mean position?
13. What is the time period for the function $f(t) = \sin \omega t + \cos \omega t$ may represent the simple harmonic motion?
14. When is the swinging of simple pendulum considered approximately SHM?
15. Can the motion of an artificial satellite around the earth be taken as SHM?
16. What is the phase relationship between displacement, velocity and accelection in SHM?

17. What forces keep the simple pendulum in motion?
18. How will the time period of a simple pendulum change when its length is doubled?
19. What is a harmonic wave function?
20. If the motion of revolving particle is periodic in nature, give the nature of motion or projection of the revolving particle along the diameter.
21. In a forced oscillation of a particle, the amplitude is maximum for a frequency w_1 of the force, while the energy is maximum for a frequency w_2 of the force. What is the relation between w_1 and w_2 ?
22. Which property of the medium are responsible for propagation of waves through it?
23. What is the nature of the thermal change in air, when a sound wave propagates through it?
24. Why does sound travel faster in iron than in water or air?
25. When will the motion of a simple pendulum be simple harmonic?
26. A simple harmonic motion of acceleration 'a' and displacement 'x' is represented by $a + 4\pi^2x = 0$. What is the time period of S.H.M?
27. What is the main difference between forced oscillations and resonance?
28. Define amplitude of S.H.M.
29. What is the condition to be satisfied by a mathematical relation between time and displacement to describe a periodic motion?
30. Why the pitch of an organ pipe on a hot summer day is higher?
31. Under what conditions does a sudden phase reversal of waves on reflection takes place?
32. The speed of sound does not depend upon its frequency. Give an example in support of this statement.
33. If an explosion takes place at the bottom of lake or sea, will the shock waves in water be longitudinal or transverse?
34. Frequency is the most fundamental property of wave, why?

35. How do wave velocity and particle velocity differ from each other?
36. If any liquid of density higher than the density of water is used in a resonance tube, how will the frequency change?
37. Under what condition, the Doppler effect will not be observed, if the source of sound moves towards the listener?
38. What physical change occurs when a source of sound moves and the listener is stationary?
39. What physical change occurs when a source of sound is stationary and the listener moves?
40. If two sound waves of frequencies 480 Hz and 536 Hz superpose, will they produce beats? Would you hear the beats?
41. Define non dispersive medium.

2 MARKS QUESTIONS

1. Which of the following condition is not sufficient for simple harmonic motion and why?
 - (i) acceleration and displacement
 - (ii) restoring force and displacement

2. The formula for time period T for a loaded spring, $T = 2\pi\sqrt{\frac{\text{displacement}}{\text{acceleration}}}$

Does-the time period depend on length of the spring?

3. Water in a U-tube executes S.H.M. Will the time period for mercury filled up to the same height in the tube be lesser of greater than that in case of water?
4. There are two springs, one delicate and another hard or stout one. For which spring, the frequency of the oscillator will be more?
5. Time period of a particle in S.H.M depends on the force constant K and mass m of the particle $\left(T = \frac{1}{2\pi} \sqrt{\frac{m}{k}} \right)$. A simple pendulum for small angular

displacement executes S.H.M approximately. Why then is the time period of a pendulum independent of the mass of the pendulum?

6. What is the frequency of oscillation of a simple pendulum mounted in a cabin that is falling freely?
7. Why can the transverse waves not be produced in air?
8. The velocity of sound in a tube containing air at 27°C and pressure of 76 cm of Hg is 330 ms⁻¹. What will be its velocity, when pressure is increased to 152 cm of mercury and temperature is kept constant?
9. Even after the breakup of one prong of tuning fork it produces a sound of same frequency, then what is the use of having a tuning fork with two prongs?
10. Why is the sonometer box hollow and provided with holes?
11. The displacement of a particle in S.H.M may be given by

$$y = a \sin(\omega t + \phi)$$

show that if the time t is increased by $2\pi/\omega$, the value of y remains the same.

12. What do you mean by the independent behaviour of waves?
13. Define wave number and angular wave number and give their S.I. units.
14. Why does the sound travel faster in humid air?
15. Use the formula $v = \sqrt{\frac{\gamma P}{\rho}}$ to explain, why the speed of sound in air
 - (a) is independent of pressure
 - (b) increase with temperature
16. Differentiate between closed pipe and open pipe at both ends of same length for frequency of fundamental note and harmonics.
17. Bats can ascertain distances, directions, nature and size of the obstacle without any eyes, explain how?
18. In a sound wave, a displacement node is a pressure antinode and vice-versa. Explain, why.

19. How does the frequency of a tuning fork change, when the temperature is increased?
20. Explain, why can we not hear an echo in a small room?
21. What do you mean by reverberation? What is reverberation time?

THREE MARKS QUESTIONS

1. Show that for a particle in linear simple harmonic motion, the acceleration is directly proportional to its displacement of the given instant.
2. Show that for a particle in linear simple harmonic motion, the average kinetic energy over a period of oscillation, equals the average potential energy over the same period.
3. Deduce an expression for the velocity of a particle executing S.H.M when is the particle velocity (i) Maximum (ii) minimum?
4. Draw (a) displacement time graph of a particle executing SHM with phase angle ϕ equal to zero (b) velocity time graph and (c) acceleration time graph of the particle.
5. Show that a linear combination of sine and cosine function like $x(t) = a \sin \omega t + b \cos \omega t$ represents a simple harmonic Also, determine its amplitude and phase constant.
6. Show that in a S.H.M the phase difference between displacement and velocity is $\pi/2$, and between displacement and acceleration is π .
7. Derive an expression for the time period of the horizontal oscillations of a massless loaded spring.
8. Show that for small oscillations the motion of a simple pendulum is simple harmonic. Derive an expression for its time period.
9. Distinguish with an illustration among free, forced and resonant oscillations.
10. In reference to a wave motion, define the terms
 - (i) amplitude
 - (ii) time period
 - (iii) frequency
 - (iv) angular frequency
 - (v) wave length and wave number.

11. What do you understand by phase of a wave? How does the phase change with time and position.

LONG ANSWER QUESTIONS

1. Derive expressions for the kinetic and potential energies of a simple harmonic oscillator. Hence show that the total energy is conserved in S.H.M. in which positions of the oscillator, is the energy wholly kinetic or wholly potential?
2. Find the total energy of the particle executing S.H.M. and show graphically the variation of potential energy and kinetic energy with time in S.H.M. What is the frequency of these energies with respect to the frequency of the particle executing S.H.M.?
3. Discuss the Newton's formula for velocity of sound in air. What correction was applied to it by Laplace and why?
4. What are standing waves? Derive an expression for the standing waves. Also define the terms node and antinode and obtain their positions.
5. Discuss the formation of harmonics in a stretched string. Show that in case of a stretched string the first four harmonics are in the ratio 1:2:3:4,
6. Give the differences between progressive and stationary waves.
7. Give a qualitative discussion of the modes of vibrations of a stretched string fixed at both the ends.
8. Give a qualitative discussion of the different modes of vibration of an open organ pipe.
9. Describe the various modes of vibrations of a closed organ pipe.
10. What are beats? How are they produced? Briefly discuss one application for this phenomenon.
11. State Doppler's effect in sound obtain an expression for apparent frequency when source and listener move away from each other

NUMERICALS

1. The time period of a body executing S.H.M is 1s. After how much time will

its displacement be $\frac{1}{\sqrt{2}}$ of its amplitude.

2. A point describes SHM in a line 6 cm long. Its velocity, when passing through the centre of line is 18 cm s^{-1} . Find the time period.
3. Find the period of vibrating particle (SHM), which has acceleration of 45 cm s^{-2} , when displacement from mean position is 5 cm
4. A 40 gm mass produces an extension of 4 cm in a vertical spring. A mass of 200 gm is suspended at its bottom and left pulling down. Calculate the frequency of its vibration.
5. The acceleration due to gravity on the surface of the moon is 1.7 ms^{-2} . What is the time period of a simple pendulum on the moon, if its time period on the earth is 3.5 s? [$g = 9.8 \text{ ms}^{-2}$]
6. Calculate the energy possessed by stone of mass 200 g executing S.H.M of amplitude 1 cm and time period 4s.
7. A particle executes S.H.M of amplitude 25 cm and time period 3s. What is the minimum time required for the particle to move between two points 12.5 cm on either side of the mean position?
8. The vertical motion of a huge piston in a machine is approximately S.H.M with a frequency of 0.5 s^{-1} . A block of 10kg is placed on the piston. What is the maximum amplitude of the piston's S.H.M. for the block and piston to remain together?
9. At what temperature will the speed of sound be double its value at 273°K ?
10. A spring balance has a scale that reads from 0 to 50 kg. The length of the scale is 20 cm. A body suspended from this spring, when displaced and released, oscillates with a period of 0.60 s. What is the weight of the body?
11. A steel wire 80 cm long has a mass 8 mg. If the wire is under tension of 400 N, what is the speed of transverse waves in the wire?
12. You are riding in an automobile of mass 3000 kg. Assuming that you are examining the oscillation characteristics of its suspension system. The suspension sags 15 cm when the entire automobile is placed on it. Also, the amplitude of oscillation decreases by 50% during one complete oscillation, Estimate the values of (a) the spring constant and (b) the damping constant 'b' for the spring and shock absorber system of one wheel assuming that each wheel supports 750 kg.

13. A string of mass 2.5 kg is under a tension of 200N. The length of the stretched string is 20m. If a transverse jerk is struck at one end of the string, how long does the disturbance take to reach the other end?
14. A steel wire has a length of 12.0 m and a mass of 2.10 kg. What should be the tension in the wire so that the speed of a transverse wave on the wire equals the speed of sound in day air at 20°C (is equal to 343 ms⁻¹)?
15. The equation of a plane progressive wave is given by the equation $y = 10 \sin 2\pi (t - 0.005x)$ where y and x are in cm and t in seconds. Calculate the amplitude, frequency, wave length and velocity of the wave.
16. Find the frequency of note emitted (fundamental note) by a string 1m long and stretched by a load of 20 kg, if this string weighs 4.9 g. Given, $g = 980 \text{ cms}^{-2}$
17. A pipe 20 cm long is closed at one end, which harmonic mode of the pipe is resonantly excited by a 430 Hz source? Will this same source can be in resonance with the pipe, if both ends are open? Speed of sound = 340 ms⁻¹
18. One end of a long string of linear mass density $8.0 \times 10^{-3} \text{ kg m}^{-1}$ is connected to an electrically driven tuning fork of frequency 256 Hz. The other end passes over a pulley and is tied to a pan containing a mass of 90 kg. The pulley end absorbs all the incoming energy so that reflected waves at this end have negligible amplitude. At $t = 0$, the left end of the string $x = 0$ has zero transverse displacement ($y = 0$) and is moving along positive x direction. The amplitude of wave is 5.0 cm. Write down the transverse displacement y as function of x and t that describes the wave on the string.
19. The transverse displacement of a string (clamped at its two ends) is given by

$$y(x,t) = 0.06 \sin \frac{2\pi}{3} x \cos(120\pi t)$$

where x, y are in m and t is in s. The length of the string is 1.5 m and its mass is $3.0 \times 10^{-2} \text{ kg}$. Answer the following.

- (a) Does the function represent a travelling or a stationary wave?
- (b) Interpret the wave as a superposition of two waves travelling in opposite directions. What are the wavelength frequency and speed of propagation of each wave?

- (c) Determine the tension in the string.
20. A wire stretched between two rigid supports vibrates in its fundamental mode with a frequency 45 Hz . The mass of the wire is $3.5 \times 10^{-2} \text{ kg}$ and its linear density is $4.0 \times 10^{-2} \text{ kg m}^{-1}$. What is (a) the speed of transverse wave on the string and (b) the tension in the string?
21. A steel rod 100 cm long is clamped at its middle. The fundamental frequency of longitudinal vibrations of the rod is given to be 2.53 kHz . What is the speed of sound in steel?

ANSWERS OF ONE MARK QUESTIONS

- No effect on time period when amplitude of pendulum is increased or decreased.
- The spring constant of a spring is the change in the force it exerts, divided by the change in deflection of the spring.
- Not at the mid point, between mean and extreme position. it will be at

$$x = a/\sqrt{2}.$$
- P.E. or K.E. completes two vibrations in a time during which S.H.M completes one vibration or the frequency of P.E. or K.E. is double than that of S.H.M
- The frequency of total energy of particle in S.H.M is zero because it remains constant.
- Length of the seconds pendulum proportional to (acceleration due to gravity)
- Increased
- As $T \propto \frac{1}{\sqrt{g}}$, T will increase.
- In the $y-z$ plane or in plane perpendicular to x -axis.
- It is the angle covered per unit time or it is the quantity obtained by multiplying frequency by a factor of 2π .

$$\omega = 2\pi \nu, \text{ S.I. unit is } \text{rad s}^{-1}$$

11. Intensity = amplitude² $\propto \frac{1}{(\text{distance})^2}$
 \therefore required ratio = y/x
12. No, the resultant of Tension in the string and weight of bob is not always towards the mean position.
13. $T = 2\pi/\omega$
14. Swinging through small angles.
15. No, it is a circular and periodic motion but not SHM.
16. In SHM, –The velocity leads the displacement by a phase $\Pi/2$ radians and acceleration leads the velocity by a phase $\Pi/2$ radians.
17. The component of weight ($mg \sin\theta$)
18. $\sqrt{2}$ times, as $T \propto \sqrt{\ell}$
19. A harmonic wave function is a periodic function whose functional form is sine or cosine.
20. S.H.M
21. Both amplitude and energy of the particle can be maximum only in the case of resonance, for resonance to occur $\omega_1 = \omega_2$.
22. Properties of elasticity and inertia.
23. When the sound wave travel through air adiabatic changes take place in the medium.
24. Sound travel faster in iron or solids because iron or solid is highly elastic as compared to water (liquids) or air (gases).
25. When the displacement of bob from the mean position is so small that $\sin \theta \approx \theta$.
26. $a = -4\pi^2x = -\omega^2x \Rightarrow \omega = 2\pi$

$$T = \frac{2\pi}{\omega} = \frac{2\pi}{2\pi} = 1 \text{ s}$$

27. The frequency of external periodic force is different from the natural frequency of the oscillator in case of forced oscillation but in resonance two frequencies are equal.
28. The maximum displacement of oscillating particle on either side of its mean position is called its amplitude.
29. A periodic motion repeats after a definite time interval T . So, $y(t) = y(t + T) = y(t + 2T)$ etc.
30. On a hot day, the velocity of sound will be more since (frequency proportional to velocity) the frequency of sound increases and hence its pitch increases.
31. On reflection from a denser medium, a wave suffers a sudden phase reversal.
32. If sounds are produced by different musical instruments simultaneously, then all these sounds are heard at the same time.
33. Explosion at the bottom of lake or sea create enormous increase in pressure of medium (water). A shock wave is thus a longitudinal wave travelling at a speed which is greater than that of ordinary wave.
34. When a wave passes through different media, velocity and wavelength change but frequency does not change.
35. Wave velocity is constant for a given medium and is given by $v = v\lambda$. But particle velocity changes harmonically with time and it is maximum at mean position and zero at extreme position.
36. The frequency of vibration depends on the length of the air column and not on reflecting media, hence frequency does not change.
37. Doppler effect will not be observed, if the source of sound moves towards the listener with a velocity greater than the velocity of sound. Same is also true if listener moves with velocity greater than the velocity of sound towards the source of sound.
38. Wave length of sound changes.
39. The number of sound waves received by the listener changes.

40. Yes, the sound waves will produce 56 beats every second. But due to persistence of hearing, we would not be able to hear these beats.
41. A medium in which speed of wave motion is independent of frequency of wave is called non-dispersive medium. For sound, air is non dispersive medium.

ANSWERS OF TWO MARKS QUESTIONS

- Condition (i) is not sufficient, because direction of acceleration is not mentioned. In SHM, the acceleration is always in a direction opposite to that of the displacement.
- Although length of the spring does not appear in the expression for the time period, yet the time period depends on the length of the spring. It is because, force constant of the spring depends on the length of the spring.
- The time period of the liquid in a U-tube executing S.H.M. does not depend upon density of the liquid, therefore time period will be same, when the mercury is filled up to the same height in place of water in the U-tube.

4. We have, $v = \frac{1}{2\pi} \sqrt{\frac{k}{m}} = \frac{1}{2\pi} \sqrt{\frac{g}{\ell}}$

So, when a hard spring is loaded with a mass m . The extension l will be lesser w.r.t. delicate one. So frequency of the oscillation of the hard spring will be more and if time period is asked it will be lesser.

5. Restoring force in case of simple pendulum is given by

$$F = \frac{mg}{l} y \Rightarrow K = mg / \ell$$

So force constant itself proportional to m as the value of k is substituted in the formula, m is cancelled out.

6. The pendulum is in a state of weight less ness i.e. $g = 0$. The frequency of pendulum

$$v = \frac{1}{2\pi} \sqrt{\frac{g}{l}} = 0$$

7. For air, modulus of rigidity is zero or it does not possess property of cohesion. Therefore transverse waves can not be produced.

8. At a given temperature, the velocity of sound is independent of pressure, so velocity of sound in tube will remain 330ms^{-1} .
9. Two prongs of a tuning fork set each other in resonant vibrations and help to maintain the vibrations for a longer time.
10. When the stem of the a tuning fork gently pressed against the top of sonometer box, the air enclosed in box also vibrates and increases the intensity of sound. The holes bring the inside air incontact with the outside air and check the effect of elastic fatigue.
11. The displacement at any time t is

$$y = a \sin(\omega t + \phi)$$

\therefore displacement at any time $(t + 2\pi/\omega)$ will be

$$y = a \sin [\omega(t + 2\pi/\omega) + \phi] = [\sin\{\omega t + \phi\} + 2\pi]$$

$$\Rightarrow y = a \sin(\omega t + \phi) [\because \sin(2\pi + \phi) = \sin\phi]$$

Hence, the displacement at time t and $(t + 2\pi/\omega)$ are same.

12. When a number of waves travel through the same region at the same time, each wave travels independently as if all other waves were absent. This characteristic of wave is known as independent behaviour of waves. For example we can distinguish different sounds in a full orchestra.
13. Wave number is the number of waves present in a unit distance of medium. ($\bar{\nu} = 1/\lambda$). S.I. unit is m^{-1} .

Angular wave number or propagation constant is $2\pi/\lambda$. It represents phase change per unit path difference and denoted by $k = 2\pi/\lambda$. S.I. unit of k is rad m^{-1} .

14. Because the density of water vapour is less than that of the dry air hence density of air decreases with the increase of water vapours or humidity and velocity of sound inversely proportional to square root of density.

15. Given, $v = \sqrt{\frac{\gamma P}{\rho}}$

(a) Let V be the volume of 1 mole of air, then

$$\rho = \frac{M}{V} \quad \text{or} \quad V = \frac{M}{\rho}$$

for 1 mole of air $PV = RT$

$$\therefore \frac{PM}{\rho} = RT \quad \text{or} \quad \frac{P}{\rho} = \frac{RT}{M}$$

$$\Rightarrow v = \sqrt{\frac{\gamma RT}{M}} \quad (i)$$

So at constant temperature v

is constant as γ , R and M are constant

- (b) From equation (i) we know that $v \propto \sqrt{T}$, so with the increase in temperature velocity of sound increases.
16. (i) In a pipe open at both ends, the frequency of fundamental note produced is twice as that produced by a closed pipe of same length.
- (ii) An open pipe produces all the harmonics, while in a closed pipe, the even harmonics are absent.
17. Bats emit ultrasonic waves of very small wavelength (high frequencies) and so high speed. The reflected waves from an obstacle in their path give them idea about the distance, direction, nature and size of the obstacle.
18. At the point, where a compression and a rarefaction meet, the displacement is minimum and it is called displacement node. At this point, pressure difference is maximum i.e. at the same point it is a pressure antinode. On the other hand, at the mid point of compression or a rarefaction, the displacement variation is maximum i.e. such a point is pressure node, as pressure variation is minimum at such point.
19. As the temperature increases, the length of the prong of the tuning fork increases. This increases the wavelength of the stationary waves set up in the tuning fork. As frequency, $\nu \propto \sqrt{\frac{1}{\lambda}}$, so frequency of the tuning fork decreases.
20. For an echo of a simple sound to be heard, the minimum distance between the speaker and the walls should be 17m, so in any room having length less than 17 m, our ears can not distinguish between sound received directly and sound received after reflection.

21. The phenomenon of persistence or prolongation of sound after the source has stopped emitting sound is called reverberation. The time for which the sound persists until it becomes inaudible is called the reverberation time.

SOLUTION / HINTS OF NUMERICALS

1. Soln : $y = r \sin \omega t = r \sin \frac{2\pi}{T} t$

Here $y = \frac{1}{3} r$ and $T = 1\text{ s}$

$$\therefore \frac{1}{\sqrt{2}} r = r \sin \frac{2\pi}{T} t \Rightarrow 2\pi t = \pi/4$$

$$\Rightarrow t = \frac{1}{8} \text{ s}$$

2. Soln : Here amplitude $r = 6/2 = 3\text{ cm}$

When $y = 0$, $v = 18 \text{ cms}^{-1}$

$$\text{Now } v = w\sqrt{r^2 - y^2} \Rightarrow 18 = w\sqrt{3^2 - 0}$$

or $3w = 18 \Rightarrow w = 6 \text{ rad s}^{-1}$

$$\text{We know } T = \frac{2\pi}{w} = \frac{2\pi}{6} = 1.047 \text{ s}$$

3. Soln : Here $y = 5 \text{ cm}$ and acceleration $a = 45 \text{ cms}^{-2}$

We know $a = w^2 y$

$$\therefore 45 = w^2 \times 5 \text{ or } w = 3 \text{ rad s}^{-1}$$

$$\text{And } T = \frac{2\pi}{w} = \frac{2\pi}{3} = 2.095 \text{ s}$$

4. Soln :

Here $mg' = 40 \text{ g} = 40 \times 980 \text{ dyne}$; $l = 4 \text{ cm}$.

say k is the force constant of spring, then

$$mg = kl \text{ or } k = mg/\ell$$

$$k = \frac{40 \times 980}{4} = 9800 \text{ dyne cm}^{-1}$$

when the spring is loaded with mass $m = 200 \text{ g}$

$$v = \frac{1}{2\pi} \sqrt{\frac{k}{m}} = \frac{1}{2\pi} \sqrt{\frac{9800}{200}}$$

$$= 1.113 \text{ s}^{-1}$$

5. Soln : Here on earth, $T = 3.5 \text{ s}$; $g = 9.8 \text{ ms}^{-2}$

for simple pendulum $T = 2\pi\sqrt{\frac{\ell}{g}}$

$$3.5 = 2\pi\sqrt{\frac{\ell}{9.8}} \quad (\text{i})$$

on moon, $g' = 1.7 \text{ ms}^{-2}$ and if T' is time period

$$\text{then } T' = 2\pi\sqrt{\frac{\ell}{1.7}} \quad (\text{ii})$$

Dividing eq(ii) by eq.(i), we get

$$\frac{T'}{3.5} = \sqrt{\frac{9.8}{1.7}} \quad \text{or} \quad T' = \sqrt{\frac{9.8}{1.7}} \times 3.5 = 8.4 \text{ s}$$

6. Solu. : $E = 2\pi^2 m r^2 v^2 = \frac{2\pi^2 m r^2}{T^2}$

$$m = 0.2 \text{ kg}, r = 0.01 \text{ m}, T = 4\text{s}$$

$$\therefore E = \frac{2\pi^2 \times 0.2 \times (0.01)^2}{4^2} = 0.00246 \text{ J}$$

7. Soln :

Given, $r = 25 \text{ cm}$; $T = 3\text{s}$; $y = 12.5 \text{ cm}$

$$\text{The displacement } y = r \sin \frac{2\pi}{T} t$$

$$12.5 = 25 \sin \frac{2\pi}{3} t \quad \text{or} \quad \frac{2\pi}{3} t = \frac{\pi}{6} \quad \text{or} \quad t = 0.25 \text{ s.}$$

The minimum time taken by the particle $2t = 0.5 \text{ s}$

8. Soln : Given, $\nu = 0.5 \text{ s}^{-1}$ $g = 9.8 \text{ ms}^{-1}$

$$a = \omega^2 y = (2\pi\nu)^2 y = 4\pi^2 \nu^2 y$$

a_{max} at the extreme position i.e. $r = y$

$a_{\text{max}} = 4\pi^2 \nu^2 r$ and $a_{\text{max}} = g$ to remain in contact.

$$\text{or } r = \frac{g}{4\pi^2 \nu^2} = \frac{9.8}{4\pi^2 \times (0.5)^2} = 0.993 \text{ m}$$

9. Say v_1 in the velocity of sound at $T_1 = 273^\circ\text{K}$ and $v_2 = 2v_1$ at temperature T_2

$$\text{Now } \frac{v_2}{v_1} = \sqrt{\frac{T_2}{T_1}} \quad \therefore \frac{2v_1}{v_1} = \sqrt{\frac{T_2}{273}}$$

$$\text{or } T_2 = 4 \times 273 = 1092^\circ\text{K}$$

10. Here $m = 50 \text{ kg}$, $l = 0.2 \text{ m}$

$$\text{we know } mg = kl \quad \text{or} \quad k = \frac{mg}{l} = \frac{50 \times 9.8}{0.2} = 2450 \text{ Nm}^{-1}$$

$T = 0.60 \text{ s}$ and M is the mass of the body, then using

$$T = 2\pi \sqrt{\frac{M}{k}} \Rightarrow M = \frac{2450 \times (0.60)^2}{4\pi^2} = 22.34 \text{ kg}$$

$$\text{Weight of body } Mg = 22.34 \times 9.8 = 218.93 \text{ N.}$$

11. Soln : Speed of wave (transverse) in stretched string

$$v = \sqrt{\frac{T}{m}} \quad T \text{ is Tension, } m \text{ is mass per unit length}$$

$$v = \sqrt{\frac{400}{\frac{8 \times 10^{-3}}{0.8}}} = 200 \text{ ms}^{-1}$$

12. Soln :

(a) Here $m = 3000$ kg, $x = 0.15$ m

If k is the spring constant of each spring, then spring constant for four spring connected in parallel will be $4k$.

$$\therefore 4k x = mg \text{ or } k = \frac{mg}{x}$$

$$k = \frac{3000 \times 10}{4 \times 0.15} = 5 \times 10^4 \text{ Nm}^{-1}$$

(b) As $A' = A e^{-bt/2m} \therefore \frac{A}{2} = A e^{-bt/2m}$ or $2 = e^{bt/2m}$

$$\text{or } \log_e 2 = \frac{bt}{2m} \log_e e = \frac{bt}{2m} \quad \text{or } b = \frac{2m \log_e 2}{t}$$

$$\text{But } t = 2\pi \sqrt{\frac{m}{4k}} = 2 \times \frac{22}{7} \times \sqrt{\frac{3000}{4 \times 5 \times 10^4}} = \frac{40}{70} \sqrt{\frac{3}{2}} \text{ s}$$

$$\text{Hence } b = \frac{2 \times 750 \times 0.693}{\frac{40}{70} \sqrt{\frac{3}{2}}} = 1350.4 \text{ kg s}^{-1}$$

13. Soln : Given $T = 200$ N, length of string $l = 20$ m

total mass of the string = 2.5 kg

\therefore mass per unit length of the string

$$m = \frac{2.5}{20} = 0.125 \text{ kg m}^{-1}$$

$$\text{Now } v = \sqrt{\frac{T}{m}} = \sqrt{\frac{200}{0.125}} = 40 \text{ ms}^{-1}$$

Hence time taken by the transverse wave to reach other end

$$t = \frac{\ell}{v} = \frac{20}{40} = 0.5 \text{ s}$$

14. Soln : Given speed of sound in air, $v = 343$ ms^{-1}

length of wire, $l = 12.0$ m, total mass of wire $M = 2.10$ kg

$$m = \frac{M}{l} = \frac{2.10}{12.0} = 0.175 \text{ kgm}^{-1}$$

Now

$$\nu = \sqrt{\frac{T}{m}} \Rightarrow T = \nu^2 m = (343)^2 \times 0.175 = 20,588.6\text{N} = 2.06 \times 10^4 \text{N}$$

15. Solu, here $y = 10 \sin 2\pi (t - 0.005x)$

$$y = 10 \sin \frac{2\pi}{200} (200t - x) \quad (\text{i})$$

The equation of a travelling wave is given by

$$y = a \sin \frac{2\pi}{\lambda} (vt - x) \quad (\text{ii})$$

Comparing the equation (i) and (ii), we have

$$\alpha = 10 \text{ cm}, \lambda = 200 \text{ cm and } \nu = 200 \text{ ms}^{-1}$$

NOW
$$\nu = \frac{v}{\lambda} = \frac{200}{200} = 1 \text{ Hz}$$

16. Solu, $L = 100 \text{ cm}$ $T = 20 \text{ kg} = 20 \times 1000 \times 980 \text{ dyne}$

$$m = \frac{4.9}{100} = 0.049 \text{ g cm}^{-1}$$

Now the frequency of fundamental note produced,

$$\nu = \frac{1}{2L} \sqrt{\frac{T}{m}}$$

$$\nu = \frac{1}{2 \times 100} \sqrt{\frac{20 \times 1000 \times 980}{0.049}} = 100 \text{ Hz}$$

17. Solu : The frequency of n^{th} mode of vibration of a pipe closed at one end is given by

$$\nu_n = \frac{(2n - 1) \nu}{4L}$$

river $v = 340 \text{ ms}^{-1}$, $L = 20 \text{ cm} = 0.2 \text{ m}$; $v_n = 430 \text{ Hz}$

$$\therefore 430 = \frac{(2n - 1) \times 340}{4 \times 0.2} \Rightarrow n = 1$$

Therefore, first mode of vibration of the pipe is excited, for open pipe since n must be an integer, the same source can not be in resonance with the pipe with both ends open

18. Solu : The wave is travelling along x-axis and its equation is given by

$$y = a \sin \frac{2\pi}{\lambda} (vt - x) = a \sin \left(\frac{2\pi}{\lambda} vt - \frac{2\pi}{\lambda} x \right)$$

$$y = a \sin (2\pi vt - kx) = a \sin(\omega t - kx) \quad (i)$$

To determine a , ω and k :

$$a = 5.0 \text{ cm} = 0.05 \text{ m}, v = 256 \text{ Hz}$$

$$w = 2\pi v = 2\pi \times 256 = 1.61 \times 10^3 \text{ s}^{-1}$$

$$m = 8.0 \times 10^{-3} \text{ kg m}^{-1}, T = 90 \times 9.8 \text{ N}$$

$$v = \sqrt{\frac{T}{m}} = \sqrt{\frac{90 \times 9.8}{8.0 \times 10^{-3}}} = 332 \text{ ms}^{-1}$$

$$\therefore \lambda = \frac{v}{v} = \frac{332}{256} = 1.297 \text{ m}$$

$$\text{and } k = \frac{2\pi}{\lambda} = \frac{2\pi}{1.297} = 4.84 \text{ m}^{-1}$$

substituting for a , w and k in equ (i) we have

$$y = 0.05 \sin (1.61 \times 10^3 t - 4.84 x)$$

$$19. y(x, t) = 0.06 \sin \frac{2\pi}{3} x \cos 120 \pi t \quad (i)$$

- (a) The displacement which involves harmonic functions of x and t separately represents a stationary wave and the displacement, which is harmonic function of the form $(vt \pm x)$, represents a travelling wave. Hence, the equation given above represents a stationary wave.

- (b) When a wave pulse $y_1 = a \sin \frac{2\pi}{\lambda} (vt - x)$ travelling along x-axis is superimposed by the reflected pulse.

$y_2 = -a \sin \frac{2\pi}{\lambda} (vt + x)$ from the other end, a stationary wave is formed and is given by

$$y = y_1 + y_2 = -2a \sin \frac{2\pi}{\lambda} \times \cos \frac{2\pi}{\lambda} vt \quad \text{(ii)}$$

comparing the eqs (i) and (ii) we have

$$\frac{2\pi}{\lambda} = \frac{2\pi}{3} \quad \text{or} \quad \lambda = 3 \text{ m}$$

$$\text{and } \frac{2\pi}{\lambda} v = 120\pi \text{ or } v = 60\lambda = 60 \times 3 = 180 \text{ ms}^{-1}$$

$$\text{Now frequency } \gamma = \frac{v}{\lambda} = \frac{180}{3} = 60 \text{ Hz}$$

- (c) Velocity of transverse wave in a string is given by

$$v = \sqrt{\frac{T}{m}}$$

$$\text{Here } m = \frac{3 \times 10^{-2}}{1.5} = 2 \times 10^{-2} \text{ kgm}^{-1}$$

$$\text{Also } v = 180 \text{ ms}^{-1}$$

$$\therefore T = v^2 m = (180)^2 \times 2 \times 10^{-2} = 648 \text{ N}$$

20. Solution : frequency of fundamental mode, $v = 45 \text{ Hz}$

Mass of wire $M = 3.5 \times 10^{-2} \text{ kg}$; mass per unit length, $m = 4.0 \times 10^{-2} \text{ kgm}^{-1}$

$$\therefore \text{Length of wire} = L = \frac{M}{m} = \frac{3.5 \times 10^{-2}}{4.0 \times 10^{-2}} = 0.875 \text{ m}$$

$$\text{(a) for fundamental mode } L = \frac{\lambda}{2} \text{ or } \lambda = 2L = 0.875 \times 2 = 1.75 \text{ m}$$

$$\therefore \text{velocity } v = v\lambda = 45 \times 1.75 = 78.75 \text{ ms}^{-1}$$

(b) The velocity of transverse wave

$$v = \sqrt{\frac{T}{m}} \Rightarrow T = v^2 m = (78.75)^2 \times 4.0 \times 10^{-2} = 248.6\text{N}$$

21. Solution :

Given : $v = 2.53 \text{ kHz} = 2.53 \times 10^3 \text{ Hz}$

(L) Length of steel rod = 100 cm = 1m.

when the steel rod clamped at its middle executes longitudinal vibrations of its fundamental frequency, then

$$L = \frac{\lambda}{2} \quad \text{or} \quad \lambda = 2L = 2 \times 1 = 2\text{m}$$

The speed of sound in steel

$$v = v\lambda = 2.53 \times 10^3 \times 2 = 5.06 \times 10^3 \text{ ms}^{-1}$$

UNSOLVED QUESTION PAPER : PHYSICS

CLASS - XI

QUESTIONS (1 MARK)

1. Name the fundamental forces of nature.
2. What is moment of Inertia of a solid sphere about its diameter.
3. At what points the velocity and acceleration are zero for a particle executing simple harmonic motion
4. What is the efficiency of a Carnot engine operating between boiling point and freezing point of water?
5. What are the S.I. and C.G.S. unit of Heat? How are they related?
6. What provides restoring forces in the following cases
 - (i) A spring compressed and then left free to vibrate.
 - (ii) Pendulum disturbed from its mean position.
7. What is the value of bulk modulus for an incompressible liquid?
8. Why the aeroplanes and cars are given a streamline shape?

QUESTIONS (2 MARKS)

1. The radius of the earth is 6.37×10^6 m and its mass is 5.975×10^{24} kg. Find the earth's average density to appropriate significant figure.
2. If the position vectors of P and Q be respectively
$$(\hat{i} + 3\hat{j} - 7\hat{k}) \text{ and } (5\hat{i} - 2\hat{j} + 4\hat{k})$$
 find \overline{PQ}
3. A block is supported by a cord c from a rigid support and another cord D is attached to the bottom of the block. If you give a sudden jerk to D, it will break, but if you pull D steadily, C will break. Why?

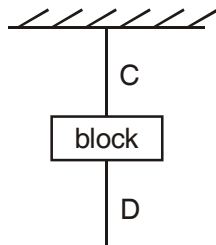

4. If earth Contracts to half its radius, what would be the duration of the day.
5. What is the height at which the value of g is the same as at a depth of $R/2$? (R is radius of earth)
6. Prove that the elastic potential energy density of a stretched wire is equal to half the product of stress and strain.
7. A particle is executing simple harmonic motion according to equation.

$$x = 5 \sin \pi t$$

where x is in cm. How long the particle take to move from the position of equilibrium to the position of maximum displacement?

8. At what temperature will the average velocity of oxygen molecules be sufficient so as to escape from the earth

mass of one molecule of oxygen = 5.34×10^{-26} kg

Boltzman constant $k = 1.38 \times 10^{-3}$ Joule/k

escape velocity from the earth = 11.0 km/s

9. Explain why
 - (a) Two bodies at different temperature T_1 and T_2 , if brought in thermal contact do not necessarily settle to the mean temperature $(T_1 + T_2)/2$
 - (b) Air pressure in a car tyre increases during driving.
10. Why no real engine can have an efficiency greater than that of a cannot engine working between the same two temperature?

QUESTIONS (3 MARKS)

1. A car travels first half of a length S with velocity v_1 . The second half is covered with velocity v_2 and v_3 for equal time intervals. Find the average velocity of the motion
2. A body of mass m is suspended by two strings making angles α and β with the horizontal as shown. Calculate the tensions in the two string

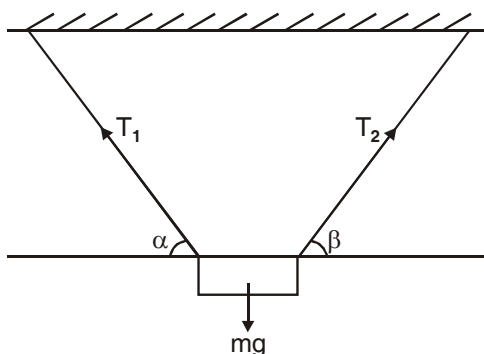

3. Define elastic collision. Prove that bodies of identical mass exchange their velocities after head on collision.
4. A body attached to a string of length l describe a vertical circle. Derive the expression for the velocity of the body and tension in the string at any point.
5. A small sphere of mass 0.1 kg and radius 2.5 cm rolls without sliding with a uniform velocity of 0.1 m/s along a straight line on a smooth horizontal table. Calculate the total energy of the sphere.

OR

The moment of inertia of a solid flywheel about its axis is $0.1 \text{ kg} - \text{m}^2$. A tangential force of 2 kg wt. is applied round the circumference of the flywheel with the help of a string and mass arrangement as shown. If the radius of the wheel is 0.1 m . Find the acceleration of the mass.

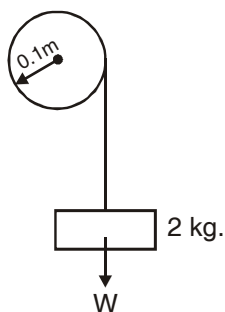

6. State and derive Kepler's law of periods for circular orbits.
7. Show that the time periods for vertical harmonic oscillations of the three system shown in fig (a), (b), and (c) in the ratio of $1 : \sqrt{2} : \frac{1}{\sqrt{2}}$

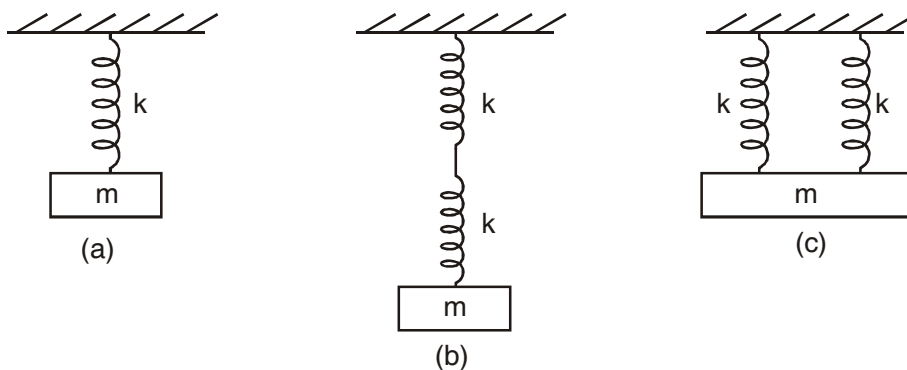

spring constant of each spring is k .

8. Two perfect gases at absolute temperature T_1 and T_2 are mixed. There is no loss of energy. Find the temperature of the mixture if masses of molecules are m_1 and m_2 and the number of molecules in the gases are μ_1 and μ_2 respectively.
9. Plot the corresponding difference circles for each of the following simple harmonic motion. Indicate the initial ($t = 0$) position of the particle, the radius of the circle and the angular speed of the rotating particle.
- (i) $x = -2 \sin(3t + \pi/3)$ (ii) $x = \cos(\pi/6 - t)$
- (The sense of rotation is taken to be anti clockwise)

QUESTIONS (5 MARKS)

1. Derive the three basic kinematic equations by calculus method.

OR

A body is projected with some initial velocity making an angle θ with the horizontal. Show that its path is parabola, find the maximum height attained and its horizontal range.

2. Why are circular road banked? Deduce an expression for safe velocity in a banked road. (with friction)

OR

The rear side of a truck is open and a box of 40 kg mass is placed 5 m away from the open end as shown in fig. The coefficient of friction between the box and the surface below it is 0.15 on a straight road the truck starts from rest and accelerates with 2 m/s^2 . At what distance from the starting point does the box fall off the truck?

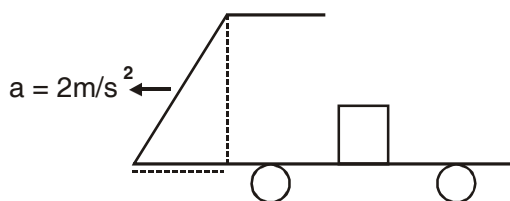

3. (i) What is the phenomenon of capillary? Derive an expression for the rise of liquid in a capillary tube.
- (ii) What happen if the length of the capillary tube is smaller than the height to which the liquid rises. Explain?

OR

Discuss stress vs strain graph explaining clearly the term elastic limit, permanent set, elastic hysteresis and tensile strength.

PHYSICS

CLASS - XI

General Instructions

- (a) Questions from question no. 1-4 carry 1 marks each, 5-12 carry 2 marks each, 13-27 carry 3 marks each and 28-30 carry 5 marks each.
- (b) There is no overall choice but one choice is given in 2 marks question, two choice in 3 marks question and all three choices in five marks question
- (c) You may use the following physical constant where ever necessary:

Speed of light $C = 3 \times 10^8 \text{ ms}^{-1}$

Gravitational constant $G = 6.6 \times 10^{-11} \text{ NM}^2 \text{ Kg}^{-2}$

Gas constant $R = 8.314 \text{ J Mol}^{-1} \text{ k}^{-1}$

Mass of electron = $9.110 \times 10^{-31} \text{ Kg}$

Mechanical equivalent of heat = 4.185 J Cal^{-1}

Standard atmospheric pressure = $1.013 \times 10^5 \text{ Pa}$

Absolute zero $0\text{K} = -273.15^\circ\text{C}$

Acceleration due to gravity = 9.8 Ms^{-2}

Use of calculator is not permitted. However you may use log table, if required. Draw neat labelled diagram wherever necessary to explain your answer.

1. A light body and heavy body have equal momentum, which one have greater kinetic energy?
2. What does speedometer of a car indicates?
3. Write down the dimensions of viscosity coefficient
4. Why do we use ball-bearings?

15. A force acting on an object is given by $\vec{F} = (3\hat{i} + 4\hat{j} - 6\hat{k})$ N and the displacement made by it is given by $\vec{X} = (6\hat{i} - 2\hat{j} - \hat{k})$. Calculate the work done and power if work is done in 2 s.
16. Define and prove conservation of linear momentum.
17. If the momentum of an object is increased by 50%, Calculate the percentage changes in its K.E.

OR

Two particles having mass ratio of 4:5 have same K.E. Calculate the ration of their linear momentum.

18. The velocity- Time relation of a particle is given by $V = (3t^2 - 2t - 1)$ m/s. Calculate using calculus method, the position and acceleration of the particle when the velocity of the particle is zero. Given the initial position of the object is 5m.
19. Express 10J of energy in a new system of units in which 100g, 10 cm, 30 sec are the fundamental units. Determine which one of them is bigger unit of energy.
20. The escape velocity (v) of a body depends upon the mass (m) of body, gravitational acceleration (g) and radius (R) of the planet. Derive the relation for escape velocity dimensionally.
21. State and Prove Work- Energy Theorem. OR Define uniform velocity of an object moving along a straight line. What will be shape of velocity time and position-time graphs of such a motion?
22. If a composite physical quantity in terms of moment of inertia I , force F , velocity V , work W and length L is define as, $Q = (IF V^2/WL^3)$. Find the **dimension** of Q and identify it.
23. Explain why a man who fall from a height on a cemented floor receive more injury then when he fall from the same height on the heap of sand.
24. Is it possible to have collision in which all the kinetic energy is **lost**? If so cite an example.

OR

Prove that mechanical energy remains conserved during motion when a body of mass m is dropped from a height h .

25. Two masses 8 kg and 12 kg are connected at the two ends of an inextensible string that passes over a frictionless pulley. Find the acceleration of the masses and tension in the string when masses are released.
26. A body of mass 1 Kg initially at rest is moved by a horizontal force of 0.5 N on a smooth friction less table. Calculate the work done by the force in 10 S and show that it is equal to the change in kinetic energy of the body
27. Two bodies of masses m_1 and m_2 ($m_1 \neq m_2$) moving with initial velocities u_1 and u_2 ($u_1 > u_2$), along a straight line in the same direction, suffer perfect head on collision. Find their velocities after collision.
28. State Parallelogram law of vector addition. Find the magnitude and direction of the resultant of two vectors A and B in terms of their magnitudes and angle between them.

OR

- 28 (i) Explain why it is easier to pull a roller than to push it.
- (ii) State Newton's laws of motion with at least one example of each. Show that Newton's second law is the real law.
29. What do you understand by friction? Explain static friction, limiting friction and kinetic friction. Which of them self adjusting in nature? Draw a graph to show the variation of frictional force with applied force.

OR

- (i) Derive the equation $S = ut + \frac{1}{2} at^2$ using graphical method.
- (ii) Show that the velocity of particle in a circular is always tangential to the circle.
30. A projectile is fired in air making an angle θ with horizontal. Show that
 - (i) Its path is parabolic in nature.
 - (ii) $\tan \theta = \frac{4H}{R}$ where H is maximum height attained and R is the range of projectile.

EXAMINATION PAPER : 2010

Time : 3 hours

Maximum Marks : 70

General Instructions :

- (i) All questions are compulsory.
- (ii) There are 30 questions in total. Questions 1 to 8 carry one mark each, questions 9 to 18 carry two marks each, questions 19 to 27 carry three marks each and question 28 to 30 carry five marks each.
- (iii) There is no overall choice. However, an internal choice has been provided in the one question of two marks; one question of three marks and all three questions of five marks each. You have to attempt only one of the choices in such questions.
- (iv) Use of calculators is not permitted.
- (v) Please write down the serial number of question before attempting it.
- (vi) You may use the following values of physical constant wherever necessary.

Boltzmann's constant $K = 1.38 \times 10^{-23} \text{ JK}^{-1}$

Avogadro's number $N_A = 6.022 \times 10^{23}/\text{mol}$

Radius of Earth $R = 6400 \text{ km}$.

1. Express one micron in metre. 1
2. What does the slope of velocity-time graph represent? 1
3. Are the magnitude and direction of $(\vec{A} - \vec{B})$ same as that of $(\vec{B} - \vec{A})$? 1
4. What is the principle of working of a rocket? 1
5. Why do we slip on a rainy day? 1
6. What is the source of the kinetic energy of the falling rain drop? 1
7. Two bodies move in two concentric circular paths of radii r_1 and r_2 with same time period. What is the ratio of their angular velocities? 1
8. State second law of thermodynamics. 1
9. If $x = at + bt^2$, where x is in metre and t in hour, what will be the unit of 'a' and 'b'? 2

10. The displacement-time graph of two bodies P and Q are represented by OA and BC respectively. What is the ratio of velocities of P and Q?

$$\angle OBC = 60^\circ \text{ and } \angle AOC = 30^\circ$$

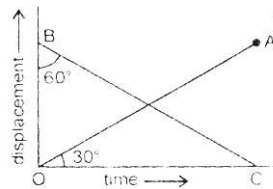

OR

- A car moving with a speed of 50 kmh^{-1} can be stopped by brakes after at least 6 m. What will be the minimum stopping distance, if the same car is moving at speed of 100 kmh^{-1} ? 2
11. A particle of mass m is moving in an horizontal circle of radius ' r ', under a centripetal force equal to (k/r^2) , where k is a constant. What is its potential energy? 2
12. Two solid spheres of the same are made of metals of different densities, which of them has larger moment of inertia about its diameter? Why? 2
13. If suddenly the gravitational force of attraction between the earth and a satellite revolving around it becomes zero, what will happen to the satellite? 2
14. When air is blown in between two balls suspended close to each other, they are attracted towards each other. Give reason. 2
15. What is an isothermal process?
Also give essential conditions for an isothermal process to take place. 2
16. Calculate the fall in temperature of helium initially at 15°C , when it is suddenly expanded to 8 times its volume. Given $\gamma = 5/3$. 2
17. Three vessels of equal capacity have gases at the same temperature and pressure. The first vessel contains neon (monoatomic), the second vessel contains chlorine (diatomic) and third contain polyatomic gas. Do the vessel contain equal number of molecules? Is the root-mean square speed of molecules same in three cases? 2

18. A particle is in linear simple harmonic motion between two points A and B, 10 cm apart, Take the direction from A to B as positive direction and give the signs of velocity and acceleration on the particle when it is
- at the end B
 - at 3 cm away from A going towards B
19. Draw displacement-time, velocity-time and acceleration-time graphs for a particle executing simple harmonic motion.

OR

A bat emits ultrasonic sound of frequency 1000 kHz in air. If the sound meets a water surface, what is the wavelength of (a) the reflected sound (b) transmitted sound? Speed of sound in air $v_a = 340 \text{ ms}^{-1}$, in water $v_w = 1486 \text{ ms}^{-1}$

- Define Absolute Zero.
 - Deduce the dimensional formula for R, using ideal gas equation $PV = nRT$
 - Find degree of freedom of a monoatomic gas.
21. What is the temperature of the steel-copper junction in the steady state of the system shown in figure. The area of cross-section of steel rod is twice that of the copper rod, $K_{\text{steel}} = 50.2 \text{ Js}^{-1} \text{ m}^{-1}\text{K}^{-1}$, $K_{\text{cu}} = 385 \text{ Js}^{-1} \text{ m}^{-1}\text{K}^{-1}$

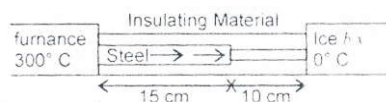

22. Define the term gravitational potential. Give its S.I. unit. Also derive expression for the gravitational potential energy at a point in the gravitational field of the earth.
23. Write S.I. unit of torque and angular momentum. Also deduce the relation between angular momentum and torque.
24. Show that the total mechanical energy of a freely falling body remains constant through out the fall.
25. Two masses 8 kg and 12 kg are connected at the two ends of a light inextensible string that goes over a frictionless pulley. Find the acceleration

of the masses, and the tension in the string when the masses are released.
 [g = 9.8 ms⁻²] 3

26. The position of a particle is given by

$$\vec{r} = 3.0t\hat{i} + 2.0t^2\hat{j} + 4\hat{k} \text{ m}$$

where t is in seconds, \vec{r} is in metres and the coefficients have the proper units.

- (a) Find the velocity v and acceleration a. 3
 (b) What is the magnitude of velocity of the particle at t = 2 s? 3
27. Discuss the nature of the motion from the given displacement-time graph. 3

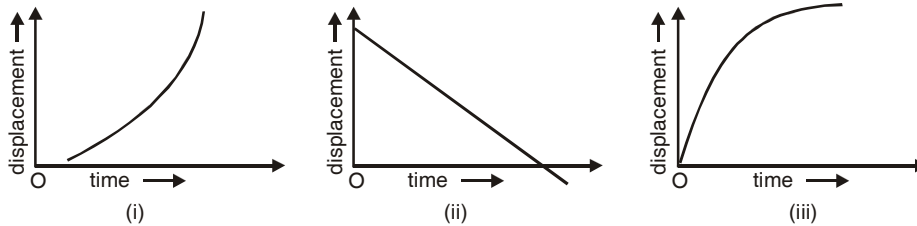

28. What is the need for Banking of road? Obtain an expression for the maximum speed with which a vehicle can safely negotiate a curved road banked at an angle θ . The coefficient of friction between the wheel and the road is μ .

OR

What do you understand by friction? Discuss about static friction, limiting friction, kinetic friction, rolling friction. Show how the force of friction f varies with the applied force F. 5

29. (i) State Pascal's law of transmission of fluid pressure. Explain how is Pascal's law applied in a hydraulic lift. (with suitable diagram)
 (ii) As shown in figure water flows from P to Q. Explain why height h_1 of column AB of water is greater than height h_2 of column CD of water.

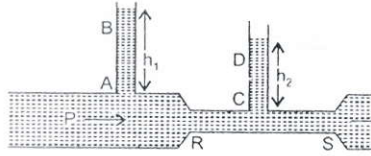

OR

- (i) Explain the terms specific heat and heat capacity.
 - (ii) State Newton's law of cooling. Derive mathematical expression for it. 5
30. Show that total mechanical energy E of a particle executing simple harmonic motion is constant and equal to $\frac{1}{2}KA^2$, where $K = m\omega^2$, $m =$ mass and ω is angular velocity and A is the maximum amplitude. Also draw the graph of potential energy, kinetic energy and total energy of the particle.

OR

Obtain an expression for a standing wave formed and obtain the position of nodes and antinodes. 5

EXAMINATION PAPER : 2011

Time : 3 hours

Maximum Marks : 70

General Instructions :

- (i) All questions are compulsory.
- (ii) There are 30 questions in total. Questions 1 to 8 carry one mark each, questions 9 to 18 carry two marks each, questions 19 to 27 carry three marks each and question 28 to 30 carry five marks each.
- (iii) There is no overall choice. However, an internal choice has been provided in the one question of two marks; one question of three marks and all three questions of five marks each. You have to attempt only one of the choices in such questions.
- (iv) Use of calculators is not permitted.
- (v) Please write down the serial number of question before attempting it.
- (vi) You may use the following values of physical constants wherever necessary.

Boltzmann's constant $K = 1.38 \times 10^{-23} \text{ JK}^{-1}$

Avogadro's number $N_A = 6.022 \times 10^{23}/\text{mol}$

Radius of Earth $R_e = 6400 \text{ km}$.

$= 1.013 \times 10^5 \text{ Pa}$

1 Atmospheric Pressure $g = 9.8 \text{ m/s}^2$

$R = 8.3 \text{ J mol}^{-1} \text{ K}^{-1}$

1. Write the dimensional formula of torque. 1
2. Draw velocity-time graph for an object, starting from rest. Acceleration is constant and remains positive. 1
3. Arrange increasing order the tension T_1 , T_2 and T_3 in the figure.

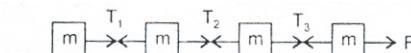

4. Why there is lack of atmosphere on the surface of moon? 1
5. The triple point of carbon dioxide is 216.55 K. Express this temperature on Fahrenheit scale. 1

6. In an open organ pipe, third harmonic is 450 Hz. What is the frequency of fifth harmonic? 1
7. Which type of substances are called elastomers? Give one example 1
8. A simple harmonic motion is described by $a = -16x$ where a is acceleration, $x \rightarrow$ displacement in m. What is the time period? 1
9. Percentage error in the measurement of height and radius of cylinder are x and y respectively. Find percentage error in the measurement of volume. Which of the two measurements height or radius need more attention? 2

OR

- The length and breadth of a rectangle are measured as $(a \pm \Delta a)$ and $(b \pm \Delta b)$ respectively. Find (i) relative error. (ii) absolute error in the measurement of area. 2
10. An object moving on a straight line covers first half of the distance at speed v and second half of the distance at speed $2v$. Find (i) average speed, (ii) mean speed. 2
 11. An object moving on a circular path in horizontal plane. Radius of the paths is r and constant speed is v . Deduce expression for centripetal acceleration. 2
 12. Find the height from the surface of earth at which weight of a body of mass m will be reduced by 36% of its weight on the surface. ($R_e = 6400$ km) 2
 13. Define gravitational potential. Give its S.I. unit. 2
 14. An engine has been designed to work between source and sink at temperature 177°C and 27°C respectively. If energy input is 3600 J. What is the work done by the engine? 2
 15. Explain :
 - (i) Why does the air pressure in a car tyre during driving increase? 2
 - (ii) Why coolant used in a chemical plant should have high specific heat? 2
 16. Calculate the work done in blowing a soap bubble from a radius of 2 cm to 3 cm. The surface tension of the soap solution is 30 dynes cm^{-1} . 2

17. Show that Newton's second law of motion is the real law of motion. 2
18. A block initially at rest breaks into two parts of masses in the ratio 2 : 3. The velocity of smaller part is $(8\hat{i} + 6\hat{j})$ m/s. Find the velocity of bigger part. 2
19. A body of mass m is released in vacuum from the position A at a height H above the ground. Prove that sum of kinetic and potential energies at A, B and C remains constant. 3

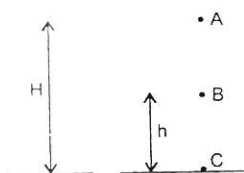

20. Give two points of difference between elastic and inelastic collisions. Two balls A and B with A in motion initially and B at rest. Find their velocities after collision (perfectly elastic). Each ball is of mass "m". 3

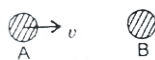

21. A liquid is in streamlined flow through a tube of non-uniform cross-section. Prove that sum of its kinetic energy, pressure energy and potential energy per unit volume remains constant. 3
22. Give reason :
- (i) fog particles appear suspended in atmosphere.
 - (ii) two boats being moved parallel to each other attract.
 - (iii) bridges are declared unsafe after long use. 3
23. State Kepler's law of Planetary motion. Name the physical quantities which remain constant during the planetary motion. 3
24. What is the law of equipartition of energy? Determine the value of γ for diatomic gas N_2 at moderate temperature. 3
25. Show that for small oscillations the motion of a simple pendulum is simple harmonic. Drive an expression for its time period. Does it depend on the mass of the bob? 3

OR

A SHM is described by $y = r \sin \omega t$. What is :

- (i) the value of displacement y at which speed of the body executing SHM is half of the maximum speed?
- (ii) the time at which kinetic and potential energies are equally shared?

3

26. A solid sphere of mass m and radius r is impure rolling on a horizontal surface. What fraction of total energy of rotation?

- (a) kinetic energy of rotation?
- (b) kinetic energy of translation?

27. Four bodies have been arranged at the corners of a rectangle shown in figure. Find the centre of mass of the system. 3

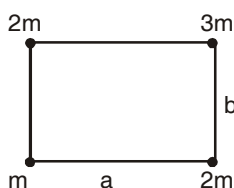

28. A body is projected with velocity m at angle θ_0 upward from horizontal. Prove that the trajectory is parabolic. Deduce expression for 5

- (i) horizontal range,
- (ii) maximum height attained.

OR

A body is projected horizontally from the top of a building of height h . Velocity of projection is u . Find : 5

- (i) the time it will take to reach the ground.
- (ii) horizontal distance from foot of building where it will strike the ground.
- (iii) velocity with which the body reach the ground.

29. Drive an expression for maximum speed a vehicle should have, to take a turn on a banked road. Hence deduce expression for angle of banking at which there is minimum wear and tear to the tyres of the vehicle. 5

OR

Define angle of friction. The inclination θ of a rough plane is increased gradually. The body on the plane just comes into motion when inclination θ becomes 30° . Find coefficient of friction the inclination is further increased to 45° . Find acceleration of the body along the plane ($g = 10 \text{ m/s}^2$) 5



30. A progressive wave is given by $y(x,t) = 8 \cos(300t - 0.15x)$. Where x in metre y in cm and t in second. What is the
- (i) direction of propagation
 - (ii) wavelength
 - (iii) frequency
 - (iv) wave speed
 - (v) phase difference between two points 0.2 in apart?

OR

Give any three differences between progressive waves and stationary waves. A stationary wave is $y = 12 \sin 300t \cos 2x$. What is the distance between two nearest nodes. 5

ANSWERS

1. $[ML^2T^{-2}]$

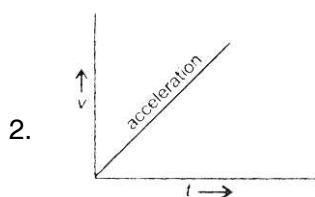

3. $T_1 < T_2 < T_3$
4. Since, the value of acceleration due to gravity 'g' is less on moon, escape velocity on surface of the moon is small and so the molecules of gases escape from the surface of the moon.

5. $K = ^\circ C + 273$

$$\Rightarrow 216.55 - 273 = ^\circ C$$

$$\Rightarrow ^\circ C = -56.55$$

$$\therefore \frac{9}{5} C + 32 = ^\circ F$$

$$\Rightarrow ^\circ F = -69.8$$

OR

$$\text{Use } \frac{^\circ F - 32}{180} = \frac{^\circ C}{100} = \frac{216.55 - 273.15}{100}$$

$$\frac{^\circ F - 32}{180} = -0.566$$

$$^\circ F - 32 = -0.566 \times 180$$

$$F = -101.88 + 32 = 69.8$$

6. $\therefore v_3 = 3v_1$

$$v_3 = 450 \text{ Hz}$$

$$\therefore 450 = 3v_1$$

$$\Rightarrow v_1 = 150 \text{ Hz}$$

Fifth harmonic, $v_5 = 5v_1$

$$= 5 \times 150$$

$$v_5 = 750 \text{ Hz}$$

7. Those materials for which stress-strain variation is not a straight line within elastic limit *e.g.* Rubber.

8. For S.H.M., $a = -\omega^2 x$

Comparing with $a = -16 x$

$$\therefore \omega = \frac{2\pi}{T} = \sqrt{16} = 4$$

$$\therefore T = \frac{\pi}{2} \text{ second}$$

9. Height of cylinder = x

Radius of cylinder = y

Volume of cylinder $V = \pi y^2 x$

Percentage error in measurement of volume

$$\frac{\Delta V}{V} \times 100 = \pm \left(2 \frac{\Delta y}{y} + \frac{\Delta x}{x} \right) \times 100$$

Hence, radius needs more attention because any error in its measurement is multiplied two times.

OR

(i) Relative error in area

$$\frac{\Delta A}{A} = \left[\frac{\Delta a}{a} + \frac{\Delta b}{b} \right]$$

as $A = ab$

(ii) Absolute error in area

$$\Delta A = \left(\frac{\Delta a}{a} + \frac{\Delta b}{b} \right) A = \left(\frac{\Delta a}{a} + \frac{\Delta b}{b} \right) ab$$

$$\Delta A = [(\Delta a)b + (\Delta b)a]$$

10. Let total distance be x. Distance of first half = $\frac{x}{2}$

Speed = v

$$\text{Time taken } t_1 = \frac{\frac{x}{2}}{v} = \frac{x}{2v}$$

Distance of second half = $\frac{x}{2}$

Speed = $2v$

$$\text{Time taken } t_2 = \frac{\frac{x}{2}}{2v} = \frac{x}{4v}$$

$$\begin{aligned} \text{(i) Average speed} &= \frac{\text{Total distance travelled}}{\text{Total time taken}} \\ &= \frac{x}{\frac{x}{2v} + \frac{x}{4v}} = \frac{4v}{3} \end{aligned}$$

$$\text{(ii) Mean speed} = \frac{v + 2v}{2} = \frac{3v}{2}$$

11. Consider a body in a circular path of radius r , with a speed V . The velocity direction is tangential at any point in the path.

The position vectors at A and B are represented by two sides of an isosceles triangle first.

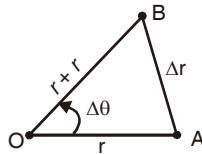

- (i) The change in position vector is indicated by $\overline{AB} = \Delta r$. The velocity at A and B are along the tangents at these points and the change in velocity will complete an isosceles triangle of velocities.
- (ii) $\overline{MN} = \overline{\Delta v}$ Since the triangles are similar,

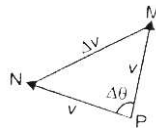

$$\frac{\Delta V}{\Delta r} = \frac{V}{r} \Rightarrow \Delta V = \frac{V}{r} \Delta r$$

$$\text{Lt}_{\Delta t \rightarrow 0} \frac{\Delta V}{\Delta r} = \text{Lt}_{\Delta t \rightarrow 0} \frac{V}{r} \frac{\Delta r}{\Delta t}$$

$$\therefore \frac{dv}{dt} = \frac{v}{r} \cdot v \Rightarrow a = \frac{v^2}{r}$$

12. $h = ?$, $R_e = 6400 \text{ km}$

$$g' = g \left(1 - \frac{2h}{R} \right) = g - \frac{2hg}{R}$$

$$\Rightarrow g - g' = \frac{2gh}{R}$$

$$\text{Percentage decrease in weight} = \frac{mg - mg'}{mg} \times 100 = \frac{g - g'}{g} \times 100$$

$$\frac{g - g'}{g} \times 100 = \frac{2gh}{gR} \times 100 = \frac{2h}{R} \times 100$$

$$36 = \frac{2 \times h}{6400} \times 100$$

$$\Rightarrow h = 1.152 \text{ km}$$

13. Gravitational potential at a point in gravitational field of a body is defined as the amount of work done in bringing a body of unit mass from infinity to that point without acceleration. Its SI unit is $\text{J}\cdot\text{kg}^{-1}$

14. $Q_1 = 3600 \text{ J}$

$$T_1 = 177 \text{ }^\circ\text{C} = 177 + 273 = 450 \text{ K}$$

$$T_2 = 27 \text{ }^\circ\text{C} = 27 + 273 = 300 \text{ K}$$

$$\frac{Q_2}{Q_1} = \frac{T_2}{T_1}$$

$$Q_2 = Q_1 \times \frac{T_2}{T_1} = 3600 \times \frac{300}{450} = 2400 \text{ J}$$

15. (i) Because work done against friction is converted into heat. Due to which the gas in tyre gets heated and hence pressure of gas increases as $P \propto T$ at constant volume.
- (ii) Because heat absorbed by a substance is directly proportional to specific heat of substance.

16. $\sigma = 30$ dynes/cm, $r_1 = 2$ cm, $r_2 = 3$ cm

$$\begin{aligned} \text{Since, bubble has two surfaces, initial surface area of bubble} &= 2 \times 4\pi r_1^2 \\ &= 2 \times 4\pi \times (2)^2 \\ &= 32\pi \text{ cm}^2 \end{aligned}$$

$$\text{Final surface area of bubble} = 2 \times 4\pi r_2^2 = 2 \times 4\pi \times (3)^2 = 72\pi \text{ cm}^2$$

$$\text{Increase in surface area} = 72\pi - 32\pi = 40\pi \text{ cm}^2$$

$$\text{Work done} = s \times \text{Increase in surface area} = 30 \times 40\pi = 3768 \text{ ergs}$$

17. **I law from II law** : According to II law, force experienced is the product of mass and acceleration. When there is no force, the mass does not accelerate and retains the same status. So the view of I law, *i.e.*, when there is no force the body maintains the status of motion is confirmed.

III law and II law : Consider two masses m_1 and m_2 exerting force on each other (internal forces). If their change in momentum are dp_1 and dp_2 , then,

$dp_1 + dp_2 = 0$. Since no external force acts on the system of two masses.

$$\therefore \frac{dp_1}{dt} = -\frac{dp_2}{dt}$$

$$\text{i.e., } f_1 = -f_2$$

i.e., force experienced by m_1 due to m_2 and by m_2 due to m_1 are equal and opposite, confirming action and reaction.

18. Let mass of the block = m

$$\text{After breaking, } m_1 = \frac{2}{5}m \text{ and } m_2 = \frac{3}{5}m$$

$$\text{Initial momentum } P_i = 0$$

$$\text{Final momentum } P_f = m_1 \vec{v}_1 + m_2 \vec{v}_2$$

According to law of conservation of momentum

$$P_f = P_i \Rightarrow m_1 \vec{v}_1 + m_2 \vec{v}_2 = 0$$

\vec{v}_1 = Velocity of smaller part, \vec{v}_2 = Velocity of bigger part

$$\Rightarrow \frac{2}{5} m (8\hat{i} + 6\hat{j}) + \frac{3}{5} m (\vec{v}_2) = 0$$

$$\Rightarrow \frac{3}{5} m \vec{v}_2 = -\frac{1}{5} m (16\hat{i} + 12\hat{j})$$

$$\vec{v}_2 = -\left(\frac{16}{3}\hat{i} + 4\hat{j}\right)$$

19. Let a body of mass m be dropped from a point A at a height H .

P.E. at A = mgh

K.E. = 0

Total energy at A = mgh

As it reaches B, it would have lost some P.E. and gained K.E.

Velocity on reaching B = $\sqrt{2gx}$

P.E. at B = $mg(h - x)$

$$\text{K.E.} = \frac{1}{2} m v_B^2 = \frac{1}{2} m 2gx = mgx$$

Total energy at B = $mg(h - x) + mgx = mgh$

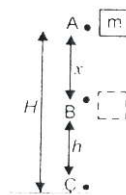

On reaching the ground C the mass must have gained a velocity $\sqrt{2gh}$ and the P E must be zero

PE at C = 0

$$\text{K.E. at C} = \frac{1}{2} m v^2 = \frac{1}{2} m (2gh) = mgh$$

Total energy at C = mgh

Thus it is proved that the energy at any point in its path is mgh.

20. **Elastic collisions** : (i) K.E. is conserved, (ii) Forces involved must be conservative.

Inelastic collisions : (i) K.E. is not conserved., (ii) Some or all forces involved may be non-conservative.

Mass of ball A and B = m

Initial velocity of ball A = $u_1 = v$

Initial velocity of ball B = $u_2 = 0$

Final velocity ball A = v_1 and of ball B = v_2

According to conservation of momentum

$$mv + m_2(0) = mv_1 + mv_2$$

$$mv = mv_1 + mv_2 \dots \dots (i)$$

Conservation of K.E.

$$\frac{1}{2}mv^2 = \frac{1}{2}mv_1^2 + \frac{1}{2}mv_2^2 \dots \dots (ii)$$

$$mv^2 = mv_1^2 + mv_2^2 \text{ From (ii)}$$

$$m(v^2 - v_1^2) = mv_2^2 \text{ (iii)}$$

From (i)

$$m(v - v_1) = mv_2 \text{ (iv)}$$

Dividing respecting sides of (iii) by (iv)

$$\frac{m(v + v_1)(v - v_1)}{m(v - v_1)} = \frac{mv_2^2}{mv_2}$$

$$\Rightarrow v_2 = v + v_1$$

Substituting in (i)

$$mv = mv_1 + m(v + v_1)$$

$$\Rightarrow v_1 = 0$$

Similarly solving,

$$v_2 = v$$

i.e., Ball A comes to rest and ball B starts moving with velocity v *i.e.*, they exchange their velocities on collision.

21. Consider an incompressible non-viscous liquid entering the cross-section A_1 at A with a velocity v_1 and coming out at a height h_2 at B with velocity v_2 .

The P.E. and K.E. increases since h_2 and v_2 are more than h_1 and v_1 respectively. This is done by the pressure doing work on the liquid. If P_1 and P_2 are the pressure at A and B, for a small displacement at A and B,

The work done on the liquid A = $(P_1 A_1)$

$$\Delta x_1 = P_1 A_1 v_1 \Delta t$$

The work done by the liquid at B = $-(P_2 A_2)$

$$\Delta x_2 = P_2 A_2 v_2 \Delta t$$

(Considering a small time Δt so that area may be same)

Net work done by pressure = $(P_1 - P_2) Av \Delta t$ since $A_1 v_1 = A_2 v_2$

From conservation of energy,

$$(P_1 - P_2)Av \Delta t = \text{change in (K.E. + P.E.)}$$

$$(P_1 - P_2) Av \Delta t = Av\rho\Delta t g(h_2 - h_1) + \frac{1}{2} Av\Delta t\rho(v_2^2 - v_1^2)$$

$$\therefore P_1 - P_2 = \rho g(h_2 - h_1) + \frac{\rho}{2}(v_2^2 - v_1^2)$$

$$\text{(i.e.) } P_1 + \rho g h_1 + \frac{\rho}{2} v_1^2 = P_2 + \rho g h_2 + \frac{\rho}{2} v_2^2$$

$$\frac{P}{\rho g} + h + \frac{v^2}{2g} = \text{constant}$$

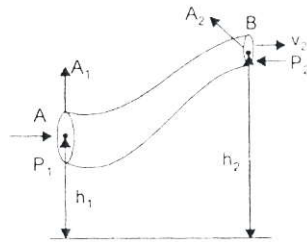

22. (i) Fog particles are formed due to condensation of water vapour as they rise up. Due to condensation, they become heavy and appear suspended.
- (ii) When two boats move in parallel directions close to each other the stream of water between boat is set into vigorous motion. As a result pressure exerted by water in between the boats becomes less than pressure of water beyond the boats. Due to this difference in pressure the boats attract each other.
- (iii) A bridge undergoes alternating stress and strain for a large number of times during its use. When bridge is used for long time, it loses its elastic strength. Therefore, the amount of strain in the bridge for a given stress will become large and ultimately, the bridge will collapse. So, they are declared unsafe after long use.
23. (i) All the planets move around in elliptical orbits with the sun at its focus.
- (ii) The line joining the sun and the planet sweeps out equal areas in equal intervals of time.
- (iii) The square of the time period of revolution of the planet is directly proportional to the cube of the semi-major axis of the elliptical orbit $T^2 \propto a^3$.

Areal velocity and angular momentum remain constant.

24. According to law of equipartition of energy for any dynamical system in thermal equilibrium the total energy is distributed equally amongst all the degrees of freedom and the energy associated with **each molecule per**

degree of freedom is $\frac{1}{2}k_B T$, where k_B is Boltzmann constant and T is temperature of the system.

Diatomic gas N_2 has 5 degrees of freedom. Using law of equipartition of energy total internal energy of one mole of gas is

$$u = 5 \times \left(\frac{1}{2} k_B T \right) \times N_A = \frac{5}{2} RT$$

$$C_v = \left(\frac{du}{dt} \right)$$

$$C_v = \frac{d}{dt} \left(\frac{1}{2} RT \right) = \frac{5}{2} R$$

$$C_p = C_v + R = \frac{5}{2} R + R = \frac{7}{2} R$$

$$\gamma = \frac{C_p}{C_v} = \frac{(7/2) R}{(5/2) R} = 1.4$$

25. Restoring force is provided by the portion $mg \sin \theta$ of gravitational force, Since, it acts perpendicular to length l , the restoring torque = $-mg \sin \theta \cdot l$

Also, $\tau = I \alpha = ml^2 \alpha$

$\therefore ml^2 \alpha = -mg \sin \theta \cdot l$

$$\alpha = -\frac{g \sin \theta}{l}$$

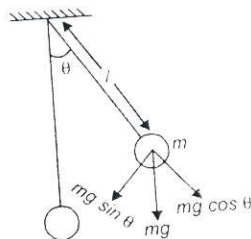

For small angles of oscillation, $\sin\theta = \theta$

$$\alpha = -\frac{g}{l} \cdot \theta$$

$$\frac{d^2\theta}{dt^2} = -\frac{g}{l} \cdot \theta \quad \text{i.e.} \quad \frac{d^2\theta}{dt^2} + \omega^2\theta = 0$$

$$\text{giving } \omega = \sqrt{\frac{g}{l}} \text{ and } T = 2\pi\sqrt{\frac{l}{g}}$$

Time period doesn't depend on mass of bob.

OR

- (i) Let the particle be at R when its velocity $V = \frac{V_{\max}}{2}$ and its displacement from the mean position O be y.

$$\text{As } v = \omega\sqrt{A^2 - y^2}$$

$$\text{So } y = \sqrt{A^2 - v^2/\omega^2}$$

$$\text{Given } v = A\omega/2,$$

$$\text{then } y = \sqrt{A^2 - \frac{A^2\omega^2}{4\omega^2}} = \frac{\sqrt{3}}{2}A$$

$$(ii) \text{ P.E.} = U_t = \frac{1}{2}m\omega^2[A^2 \sin^2 \omega t]$$

$$\text{K.E.} = \frac{1}{2}m\omega^2 A^2 \cos^2 \omega t$$

$$u = \text{K.E.}$$

$$\sin^2 \omega t = \cos^2 \omega t \Rightarrow \sin \omega t = \cos \omega t$$

$$\therefore \omega t = \frac{\pi}{4} \Rightarrow \frac{2\pi}{T} t = \frac{\pi}{4}$$

$$\Rightarrow t = \frac{T}{8}$$

26. Mass of sphere = m, Radius of sphere = r

$$\text{Moment of Inertia } I = \frac{2}{5} mr^2$$

$$\text{Total energy} = K_R + K_T$$

$$\begin{aligned} K_{\text{tot}} &= \frac{1}{2} I \omega^2 + \frac{1}{2} m v^2 \\ &= \frac{1}{2} \cdot \frac{2}{5} mr^2 \left(\frac{v^2}{r^2} \right) + \frac{1}{2} m v^2 \quad (v = r\omega) \end{aligned}$$

$$K_{\text{tot}} = \frac{1}{2} \left(\frac{7}{5} \right) m v^2$$

$$\text{Fraction of K.E. of rotation} = \frac{K_R}{K_{\text{tot}}} = \frac{\frac{1}{2} \left(\frac{2}{5} \right) m v^2}{\frac{1}{2} \left(\frac{7}{5} \right) m v^2} = \frac{2}{7}$$

$$\therefore \text{Fraction of K.E. of translation} = \frac{K_T}{K_{\text{tot}}} = \frac{5}{7}$$

27. Let $m_1 = m, m_2 = 2m, m_3 = 2m$

Let mass m_1 be at origin

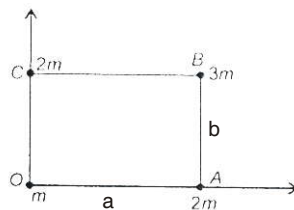

$$\therefore \text{For } m_1; x_1 = 0, y_1 = 0$$

$$\text{For } m_2; x_2 = a\hat{i}, y_2 = 0$$

$$\text{For } m_3; x_3 = a\hat{i}, y_3 = b\hat{j}$$

For m_4 ; $x_4 = 0$, $y_4 = b\hat{j}$

Coordinates of COM of the system are

$$x = \frac{m_1x_1 + m_2x_2 + m_3x_3 + m_4x_4}{m_1 + m_2 + m_3 + m_4}$$

$$= \frac{m \times 0 + 2m \times a\hat{i} + 3m \times a\hat{i} + 2m \times 0}{m + 2m + 3m + 2m}$$

$$x = \frac{5ma\hat{i}}{8m} = \frac{5a\hat{i}}{8}$$

$$y = \frac{m_1y_1 + m_2y_2 + m_3y_3 + m_4y_4}{m_1 + m_2 + m_3 + m_4}$$

$$= \frac{m \times 0 + 2m \times 0 + 3m \times b\hat{j} + 2m \times b\hat{j}}{m + 2m + 3m + 2m}$$

$$= \frac{5mb\hat{j}}{8m} = \frac{5}{8}b\hat{j}$$

\therefore Centre of mass of system is $= \frac{5}{8}(a\hat{j} + b\hat{j})$

Students may note that choice of the mass at the origin, may lead to varying result.

28. A body thrown up in space and allowed to proceed with effect of gravity alone is called projectile.

Suppose a body is projected with velocity u at an angle θ with the horizontal, $P(x, y)$ is any point on its trajectory at time t . Horizontal component of velocity is unaffected by gravity, but the vertical component ($u \sin\theta$) changes due to gravity

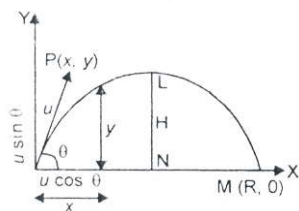

$$x = (u \cos \theta)t$$

$$y = (u \sin \theta)t - \frac{1}{2}gt^2$$

$$= u \sin \theta \times \frac{x}{u \cos \theta} - \frac{1}{2}g \left(\frac{x}{u \cos \theta} \right)^2$$

$$y = x \tan \theta - \frac{gx^2}{2u^2 \cos^2 \theta} \dots\dots\dots(i)$$

It represents the equation of a parabola, hence the path followed by a projectile is a parabola.

(i) When the body returns to the same horizontal level $y = 0$

$$\therefore 0 = x \tan \theta - \frac{gx^2}{2u^2 \cos^2 \theta} \text{ [From (i)]}$$

$$\text{or } x \tan \theta = \frac{gx^2}{2u^2 \cos^2 \theta}$$

But coordinates of M are $(r, 0)$. Putting $x = R$,

$$\text{we have } R = \frac{u^2 \sin 2\theta}{g}$$

(ii) The greatest vertical distance attained by the projectile above the horizontal plane from the point of projection is called maximum height.

Maximum height, $LN = H$

At maximum, height $v = 0$

$$\therefore v^2 - v_y^2 = -2gH,$$

where $u_y = u \sin \theta$

$$\text{or } (u \sin \theta)^2 = 2gH$$

or
$$H = \frac{u^2 \sin^2 \theta}{2g}$$

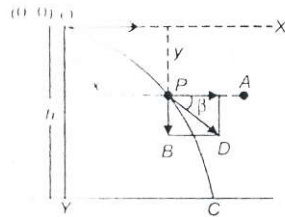

- (i) Time taken to reach the ground (Time of flight)

Let it be T

h = vertical height of point of projection O from C

Taking motion of object along OY direction

$$y_0 = 0, y = h, u_y = 0, a_y = g, t = T$$

$$y = y_0 + u_y t + \frac{1}{2} a_y t^2$$

Putting values of y_0 , y and, u_y , a_y , we have

$$h = \frac{1}{2} g T^2$$

$$\Rightarrow T = \sqrt{\frac{2h}{g}}$$

- (ii) Horizontal distance from foot of building where it will strike the ground (Horizontal range R). Taking motion of object along OX -direction; we have $x_0 = 0$, $x = R$, $u_x = u$, $a_x = 0$

$$t = T = \sqrt{\frac{2h}{g}}$$

As
$$x = x_0 + u_x t + \frac{1}{2} a_x t^2$$

Putting the values we have

$$R = u \sqrt{\frac{2h}{g}}$$

- (iii) Velocity with which body reach the ground. At any instant to the object posses two perpendicular velocities.

Horizontal velocity $v_x = u$ represented by PA

Vertical velocity v_y represented by PB

$$v_x = u_x + a_x t$$

$$v_y = 0, a_y = g, \text{ we have}$$

$$v_y = gt$$

Resultant velocity v at v_x and v_y is given by

$$v = \sqrt{v_x^2 + v_y^2}$$

$$v = \sqrt{u^2 + g^2 t^2}$$

Let \vec{v} makes an angle β with horizontal direction then

$$\tan \beta = \frac{v_y}{v_x} = \frac{gt}{u} \quad \text{or} \quad \beta = \tan^{-1} \left(\frac{gt}{u} \right)$$

29. From the forces acting on the vehicle in a banked curve (θ).

$$N \cos \theta - F_f \sin \theta = mg$$

$$N \sin \theta + F_f \cos \theta = mv^2/r. F_f = \mu N$$

Dividing the equation, we have,

$$\frac{v^2}{rg} = \frac{N \sin \theta + \mu N \cos \theta}{N \cos \theta + \mu N \sin \theta}$$

$$v^2 = rg \left[\frac{\tan \theta + \mu}{1 - \mu \tan \theta} \right] \text{ [dividing each term of right side by } N \cos \theta \text{]}$$

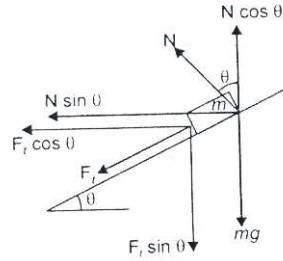

$$v = \sqrt{rg \left(\frac{\mu + \tan \theta}{1 - \mu \tan \theta} \right)}$$

If $\mu = 0$ i.e., banked road is perfectly smooth. Then from above

$$v_0 = (rg \tan \theta)^{1/2}$$

$$v_0 = rg \tan \theta$$

or $\tan \theta = \frac{v_0^2}{rg}$

OR

Angle which the resultant of force of limiting friction F and normal reaction R makes with direction of normal reaction R .

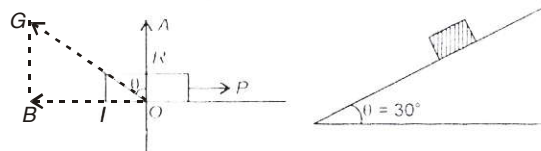

$$\theta = \tan^{-1}(\mu) = 30^\circ$$

$$\Rightarrow \mu = \tan 30^\circ = \frac{1}{\sqrt{3}}$$

Max friction $f_{\max} = \mu mg \cos 45^\circ$

$$= \frac{1}{\sqrt{3}} mg \frac{1}{\sqrt{2}}$$

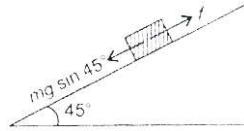

Net force

$$F = (mg \sin 45^\circ - \mu mg \cos 45^\circ)$$

$$ma = \left(\frac{mg}{\sqrt{2}} - \frac{1}{\sqrt{3}} \frac{mg}{\sqrt{2}} \right)$$

$$\begin{aligned} \therefore a &= \frac{g}{\sqrt{2}} \left[1 - \frac{1}{\sqrt{3}} \right] \\ &= \frac{10}{\sqrt{2}} \left[\frac{\sqrt{3} - 1}{\sqrt{3}} \right] = 10 \left[\frac{1.73 - 1}{\sqrt{6}} \right] \\ a &= \frac{7.3}{\sqrt{6}} = 2.99 \text{ m/s}^2 \end{aligned}$$

30. $y(x,t) = 8 \cos(300t - 0.15x)$

On comparing with $y = a \cos 2\pi \left(\frac{t}{T} - \frac{x}{\lambda} \right)$

(i) Direction of propagation is + x-axis.

(ii) Wavelength $\frac{2\pi}{\lambda} = 0.15$

$$\lambda = \frac{2\pi}{0.15} = 41.87 \text{ m}$$

(iii) $\frac{2\pi}{T} = 300$

$$2\pi\nu = 300$$

$$\nu = \frac{300}{2\pi} = 47.7 \text{ Hz}$$

(iv) $v = \lambda\nu = \frac{2\pi}{0.15} \times \frac{300}{2\pi} = 3000 \text{ m/s}$

$$\begin{aligned}
 \text{(v)} \quad \Delta\phi &= \frac{2\pi}{\lambda} \Delta x \\
 &= \frac{2\pi}{\lambda} \times 0.2 = \frac{2\pi \times 0.2 \times 0.15}{2\pi} = 0.03 \text{ radian}
 \end{aligned}$$

OR

| <i>Progressive Wave</i> | <i>Stationary Wave</i> |
|---|--|
| (i) All particles have same phase and amplitude. | (i) Amplitude varies with position. |
| (ii) Speed of motion is same. | (ii) Speed varies with position. |
| (iii) Energy is transported. | (iii) Energy is not transported. |
| (iv) Same change in pressure and density is with every point. | (iv) Pressure and density varies with point. |

$$y = 12 \sin 300t \cos 2x$$

Comparing with equation of stationary wave

$$y = 2A \sin \omega t \cos Kx$$

$$K = 2$$

$$\text{Distance between two consecutive nodes} = \frac{\lambda}{2}$$

Where λ is wavelength

$$K = \frac{2\pi}{\lambda}$$

$$\Rightarrow \frac{\pi}{(\lambda/2)} = 2$$

$$\therefore \frac{\lambda}{2} = \frac{\pi}{2}$$

So, the distance between two nearest nodes is $\frac{\pi}{2}$.