

SUPRA MkIII HANDBOOK

1. **OPERATION OF INSTRUMENTS AND CONTROLS**
 1. Overview of instruments and controls (RHD) (LHD)
 2. Keys and Doors
 3. Seats, Seat belts, Steering wheel and Mirrors
 4. Lights, Wipers and Defogger
 5. Gauges, Meters and Warning Lights
 6. Ignition switch, Transmission and Parking brake
 7. Car audio and Air conditioning system
 8. Other Equipment
2. **INFORMATION BEFORE DRIVING YOUR TOYOTA**
3. **STARTING AND DRIVING**
4. **IN CASE OF AN EMERGENCY**
5. **CORROSION PREVENTION AND APPEARANCE CARE**
6. **MAINTENANCE REQUIREMENTS**
7. **DO-IT-YOURSELF MAINTENANCE**
 1. Introduction
 2. Engine and Chassis
 3. Electrical component
8. **SPECIFICATIONS**
9. **INDEX**

OPERATION OF INSTRUMENTS AND CONTROLS



- **Overview of instruments and controls**
 - **Keys and Doors**
 - **Seats, Seat belts, Steering wheel and Mirrors**
 - **Lights, Wipers and Defogger**
 - **Gauges, Meters and Warning Lights**
 - **Ignition switch, Transmission and Parking brake**
 - **Car audio and Air conditioning system**
 - **Other Equipment**
-

OPERATION OF INSTRUMENTS AND CONTROLS



Overview of Instruments and Controls

RHD

- [Instrument Panel Overview](#)
- [Instrument Cluster Overview](#)

LHD

- [Instrument Panel Overview](#)
 - [Instrument Cluster Overview](#)
-

OPERATION OF INSTRUMENTS AND CONTROLS



Instrument Panel Overview (RHD)

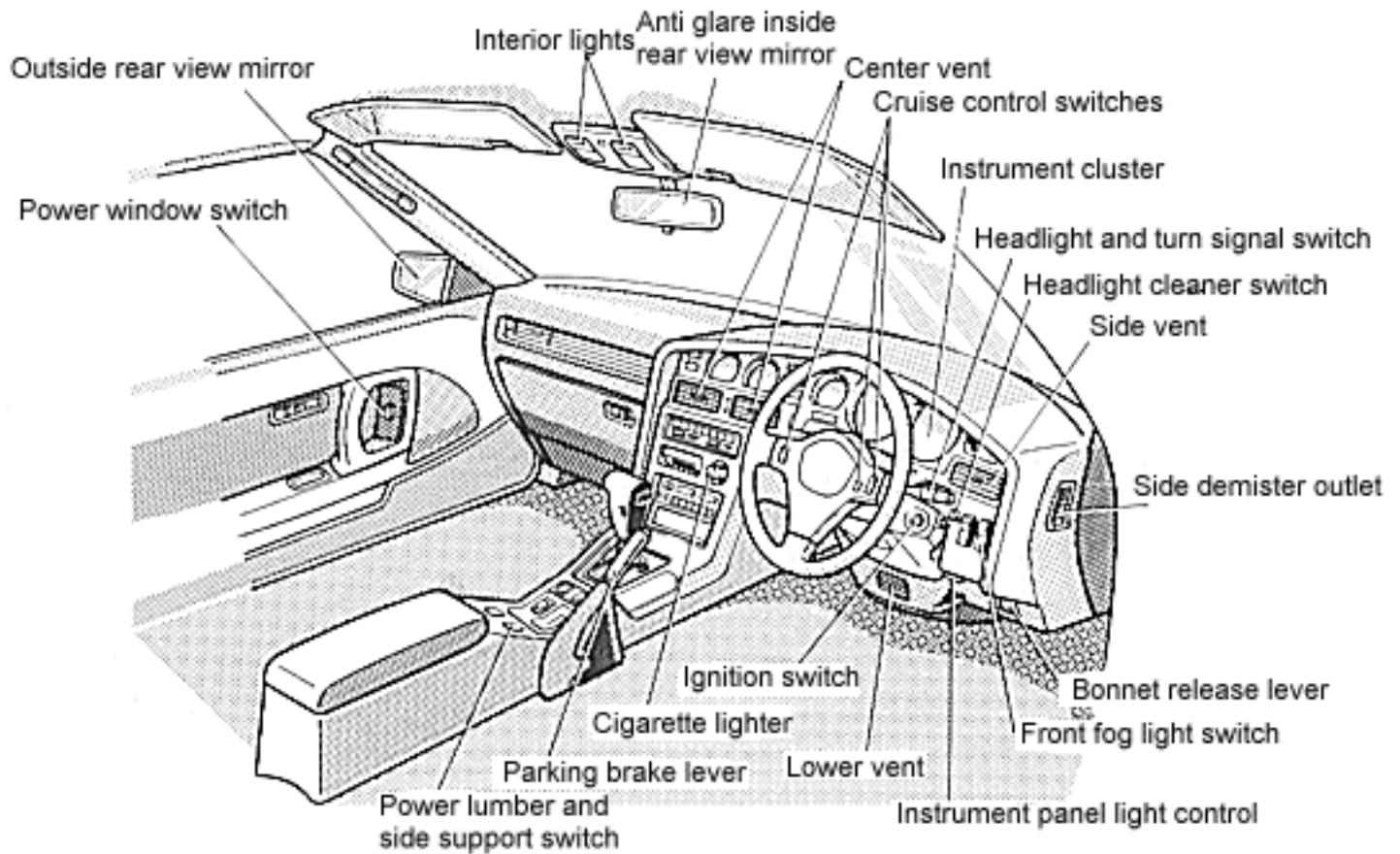

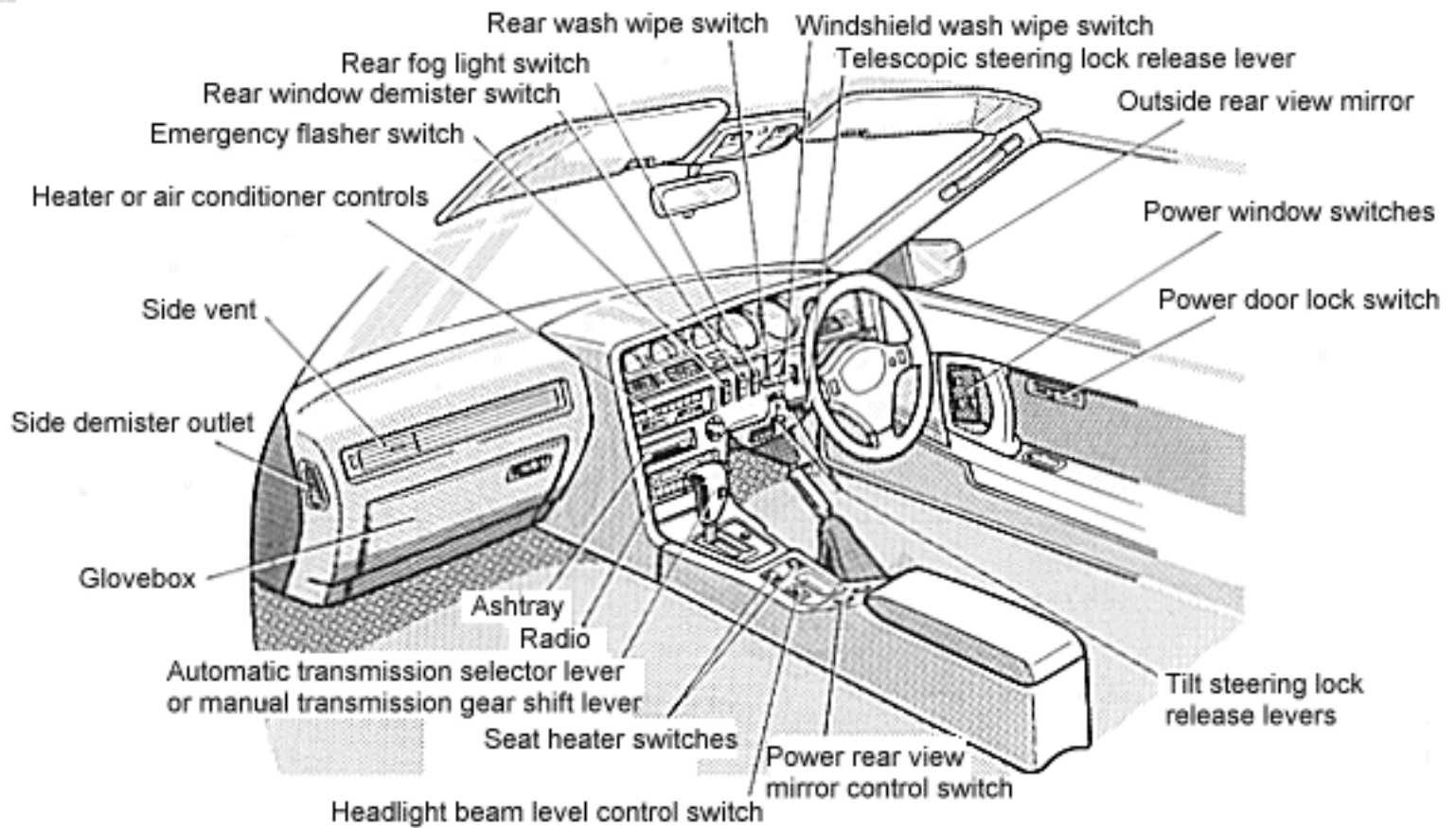

OPERATION OF INSTRUMENTS AND CONTROLS



Instrument Cluster Overview (RHD)

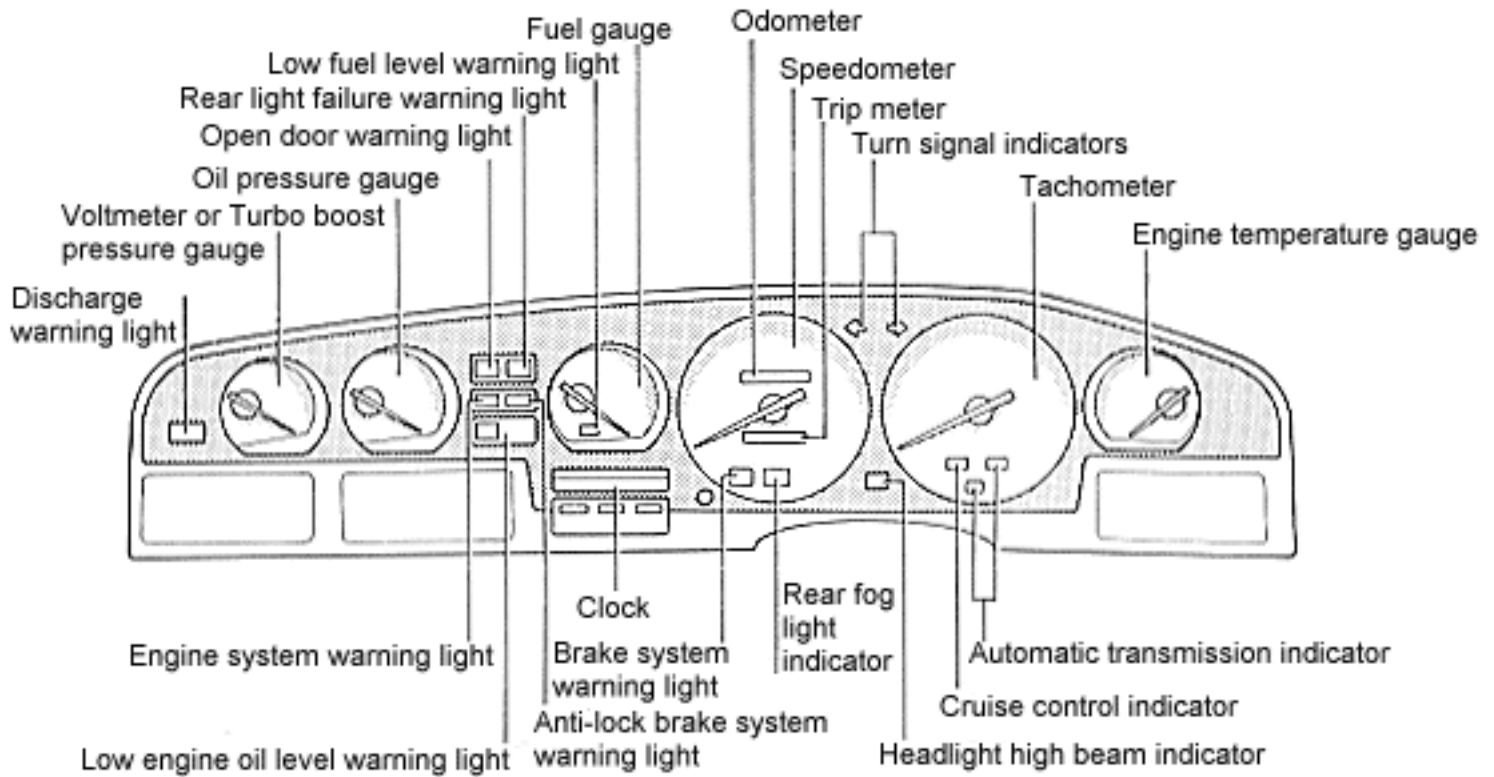

OPERATION OF INSTRUMENTS AND CONTROLS



Keys and Doors

- [Keys](#)
 - [Doors](#)
 - [Power window switches](#)
 - [Back door](#)
 - [Bonnet](#)
 - [Fuel tank cap](#)
 - [Sport roof](#)
-

OPERATION OF INSTRUMENTS AND CONTROLS



Keys

Type A

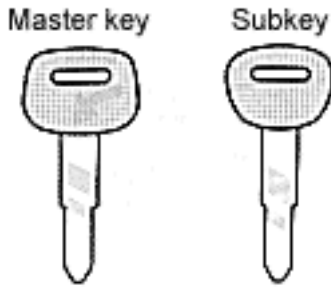

Type B

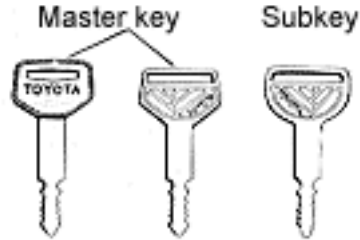

The master key works in every lock. The sub-key will not work in the glovebox.

To protect things locked in the glovebox when you have your vehicle parked, leave the subkey with the attendant.

Since the doors can be locked without a key, you should always carry a spare master key in case you

accidentally lock your keys inside the vehicle.

Keep the key number plate in a safe place such as your wallet, not in the vehicle.

If you should lose your keys or if you need additional keys, duplicates can be made by a Toyota dealer using the key number.

You should also put a copy of the key number with your important papers.

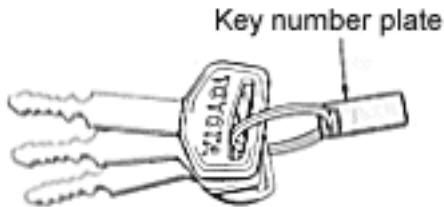

OPERATION OF INSTRUMENTS AND CONTROLS



Doors

LOCKING WITH KEY

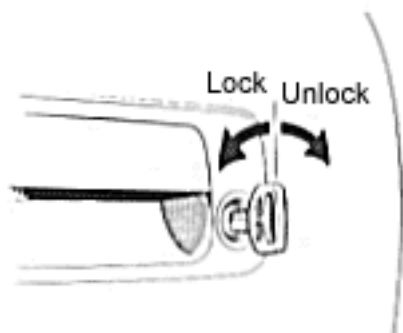

Turn the key towards the front of the vehicle to lock and towards the back to unlock.

Both side doors lock and unlock simultaneously with either door. On vehicles sold outside Switzerland, the back door will also be controlled at the same time.

LOCKING WITH INSIDE LOCK LEVER

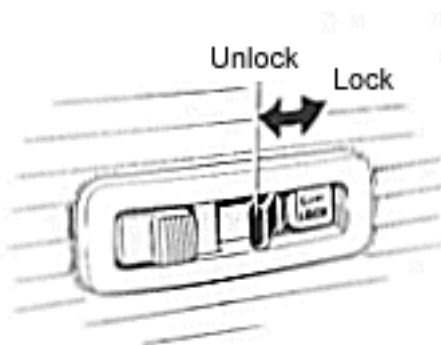

Push the lock lever forward to lock and pull it backward to unlock.

The driver's door can be opened from the inside even with the lock lever pushed forward.

If you want to lock the door from the outside, push the lever forward before closing the door. The outside door handle must be held up while the door is being closed. Be careful not to lock your keys in the vehicle. On vehicles sold outside Switzerland, the back door will also be controlled at the same time.

LOCKING WITH POWER DOOR LOCK SWITCH

To lock and unlock both side doors simultaneously, push the switch.
On vehicles sold outside Switzerland, the back door will also be controlled at the same time.

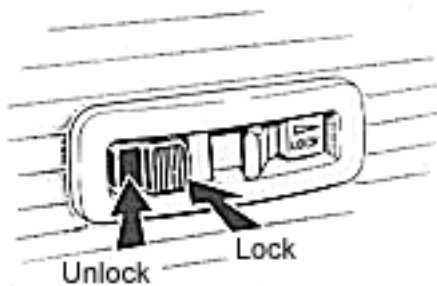

CAUTION:

- **Before driving, be sure that the doors are closed.**
- **If the doors are left unlocked in case of an accident while driving, they can be opened from the outside.**

OPERATION OF INSTRUMENTS AND CONTROLS



Power Window Switches

To raise or lower the windows, use the switch on each door. The passenger's window can also be controlled by the switches on the driver's door.

The ignition key must be in the "ON" position.

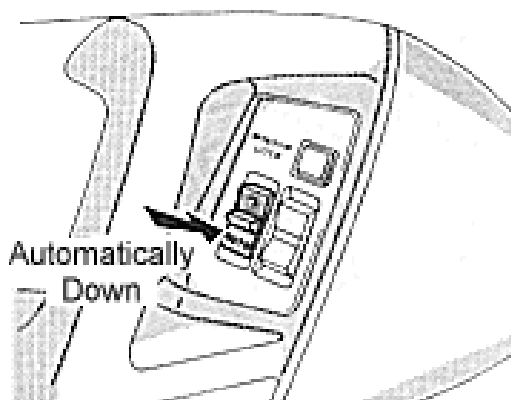
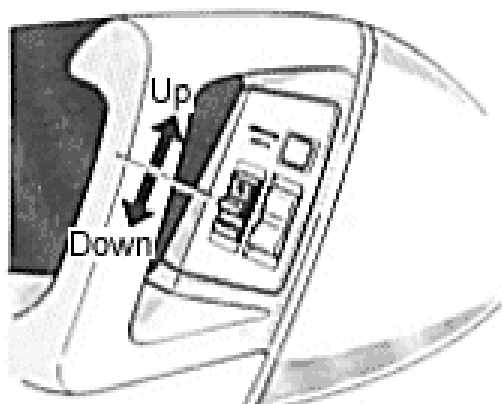

OPERATING THE DRIVER'S WINDOW

Push the center lever either way. The window moves as long as the lever is operated. For automatic operation, use the outer switch.

Push the outer switch down on the "AUTO" side. The window will fully open even if you let go of the switch. To stop the window partway, lightly push on the opposite side.

For driver's use

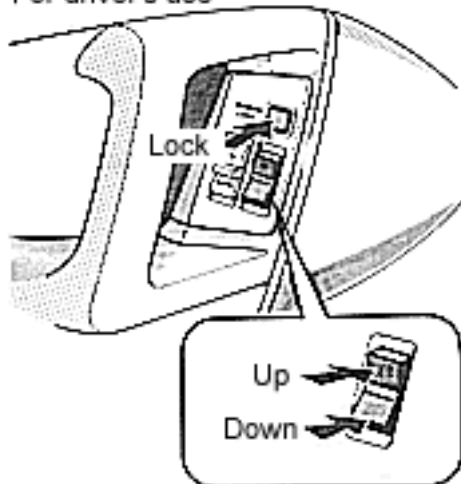

For front passenger's use

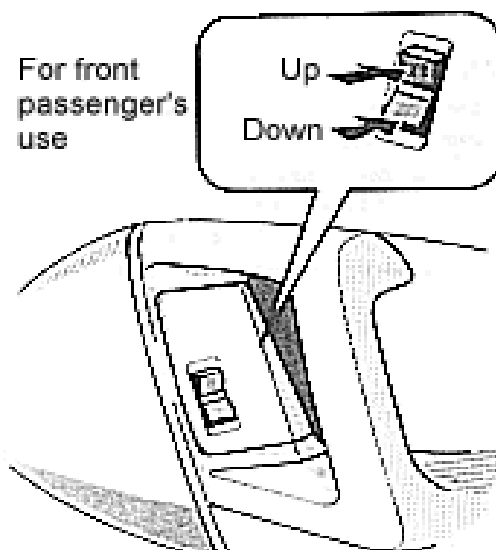

OPERATING THE PASSENGER'S WINDOW

Push the switch down on either side. The window moves as long as the switch is operated. To lock the window at that position push the "WINDOW LOCK" switch.

With the "WINDOW LOCK" switch pressed in, the window cannot be raised or lowered. The indicator lights will tell you which of the switches can be operated.

CAUTION:

To avoid personal injury, observe the following.

- **When small children are in the vehicle, take care not to allow them unexpected use of the switch. Use the window locking feature described above or, if you must leave them unattended, remove the key from the ignition switch.**
- **When closing the windows, be sure that no one has his/her head, hands or arms sticking out the window.**

OPERATION OF INSTRUMENTS AND CONTROLS



Back Door

SWITZERLAND:

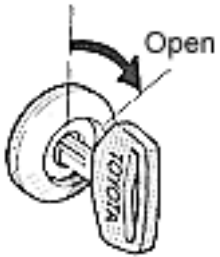

To open the back door, insert the key and turn it clockwise.

See [Luggage Stowage Precautions](#) for precautions to observe in loading luggage.

To close the back door, lower and press down on it. After closing the back door, try pulling it up to make sure it is securely closed.

EXCEPT SWITZERLAND:

Open



Unlock and Open

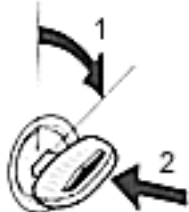

To open the back door, push the button.

If the back door is locked, insert the key and push the button with the key turned clock-wise.

See [Luggage Stowage Precautions](#) for precautions to observe in loading luggage.

Lock with Key



To close the back door, lower and press down on it. After closing the back door, try pulling it up to make sure it is securely closed.

The back door will lock if you close it with the driver's door locked. Closing the back door when the side doors are unlocked with the key or power door lock switch will allow the back door to open without a key. If you want the back door locked without locking the side doors, insert the key into the back door lock and turn it clockwise. Locking in this manner will lock the back door when closed after you open it next time.

BACK DOOR OPENER:

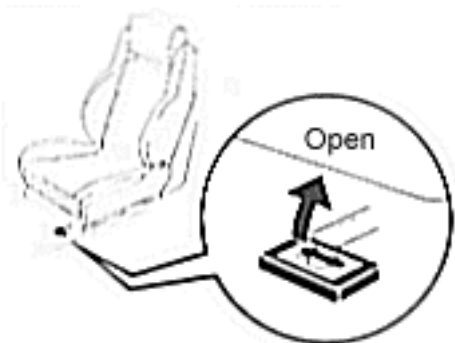

To open the back door while sitting in the driver's seat, pull the lever up.

CAUTION:

Keep the back door closed while driving. This not only keeps the luggage from being thrown out but also prevents exhaust gases from entering the vehicle.

OPERATION OF INSTRUMENTS AND CONTROLS



Bonnet

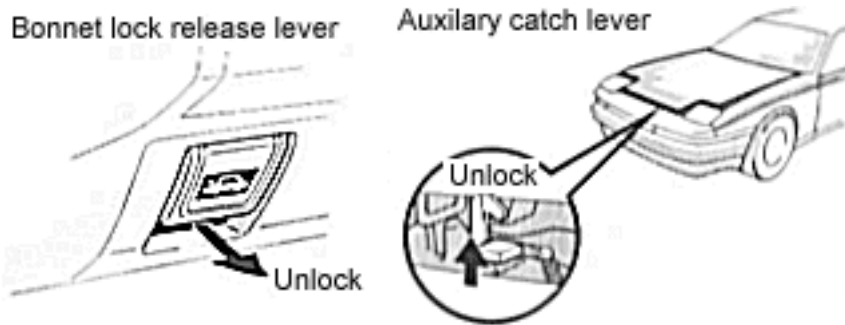

To open the bonnet, pull the bonnet lock release lever under the dash. The bonnet will spring up slightly. In front of the vehicle, press up on the auxiliary catch lever and lift the bonnet.

Before closing the hood, check to see that you have not forgotten any tools, rags, etc. Then lower the bonnet and make sure it locks into place. If necessary, press down gently on the front edge to lock it.

OPERATION OF INSTRUMENTS AND CONTROLS



Fuel Tank Cap

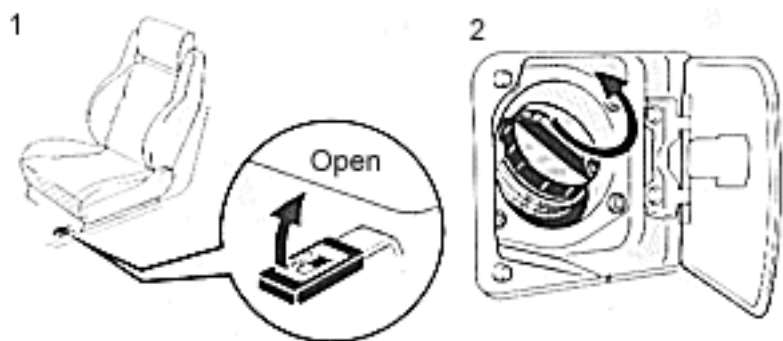

1. To open the fuel filler door, pull the lever up.
2. To remove the fuel tank cap, turn the cap slowly counterclockwise, then pause slightly before removing it.
It is not unusual to hear a slight swoosh when the cap is opened. When installing, turn the cap clockwise till you hear a click.

CAUTION:

- Do not smoke, cause sparks or allow open flames when refuelling. The fumes are inflammable.
- When opening the cab, do not remove the cap quickly. Fuel may be under pressure and spray out of the fuel filler neck under hot weather conditions, etc., which may cause injury.
- Make sure that the cap is tightened securely to prevent fuel spillage in case of an accident.
- Use only a genuine Toyota fuel tank cap for replacement. It has a built-in check valve.

OPERATION OF INSTRUMENTS AND CONTROLS



Sports Roof

DETACHING FROM VEHICLE:

1. Get the tool bag out of the console box.

In the tool bag, you will find a special kit consisting of a wrench and handle for turning the bolts, caps for covering the front bolts and plugs for stopping the rear holes.

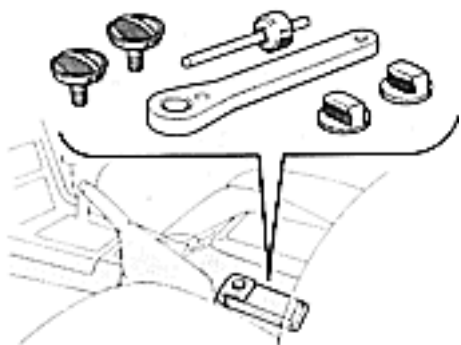

2. Loosen the bolts in the order shown by turning the wrench counterclockwise with the "LOOSEN" side of the handle toward you.

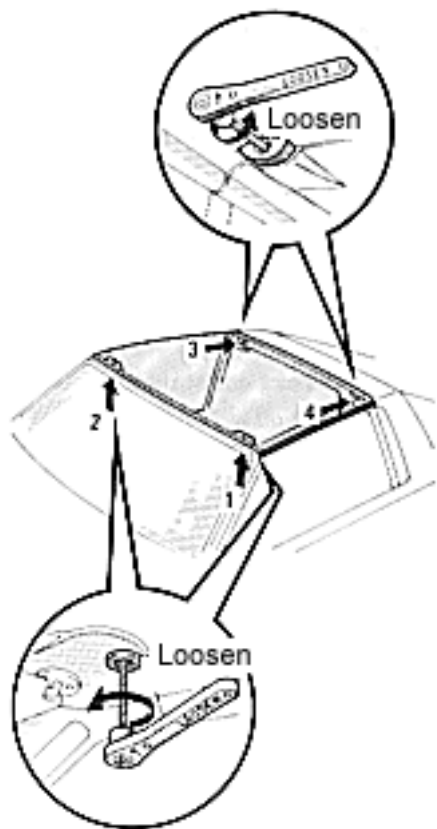

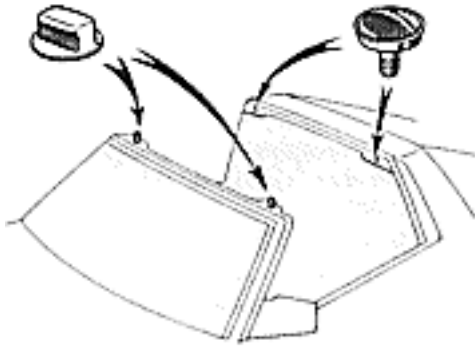

3. After removing the roof, put the caps on the front bolts, and insert the plugs into the read holes.

CAUTION:

- Do not stick your head, arms, etc. out of the opening while the vehicle is moving.
- Never attempt to remove the roof while driving.
- Do not sit on top of the vehicle around the opening.

STOWING IN LUGGAGE COMPARTMENT:

For front edge

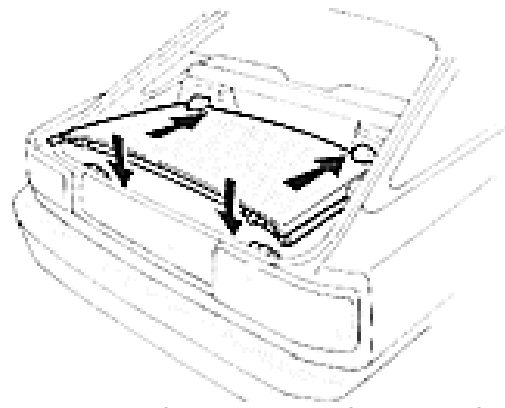
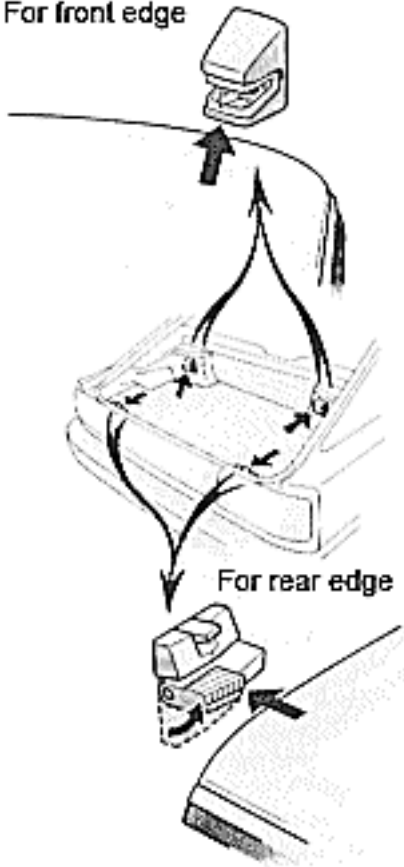

Insert the front edge of the roof to the front holders, then engage the rear edge with the rear holders.

Put the front edge on the triangle marks of the front holders.

To engage the rear edge of the roof with the rear holders, set up the holders and put the rear edge on the holders while pushing the front edge fully forward against the front holders.

NOTICE:

To avoid damaging the roof panel, do not press on the center of the stowed roof panel and do not put anything on the stowed roof panel.

CAUTION:

To minimize the risk of personal injury, make sure all four ends of the roof are securely locked in the holders after installation.

REINSTALLING ON THE VEHICLE:

Remove

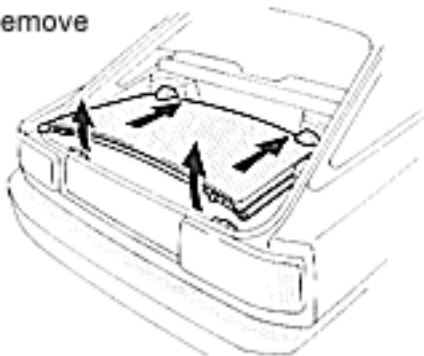

Putting rear holder back



1. Lift up the rear edge while pushing it fully forward and pull the front edge off the holders. After removing the roof, put back the holders while pulling up the lock release knob.

NOTICE:

Do not operate the knob until the roof has been removed.

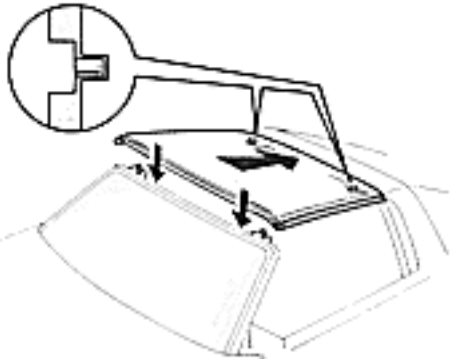

2. Place the rear edge on first and then the front edge.
Before installation, be sure to take the caps and the plugs off.

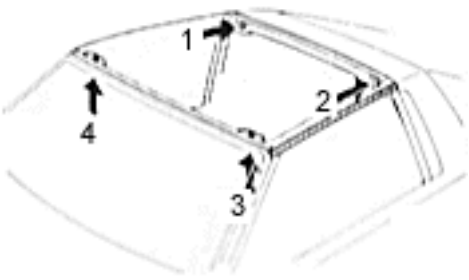

3. Tighten the bolts in the order of the rear reight, rear left, front left, and front right.
Face the "TIGHTEN" side of the wrench handle toward you, and turn it clockwise.

CAUTION:

To minimize the risk of personal injury, make sure all four ends of the roof are securely fixed on the brackets after installation.

OPERATION OF INSTRUMENTS AND CONTROLS



Seats, Seat belts, Steering wheel and Mirrors

- **Front seats**
 - **Fold-down rear seat**
 - **Headrests**
 - **Seat heater switches**
 - **Seat belts**
 - **Steering wheel**
 - **Power rear view mirror control**
 - **Folding rear view mirrors**
 - **Anti-glare inside rear view mirror**
-

OPERATION OF INSTRUMENTS AND CONTROLS



Front Seats

FRONT SEAT ADJUSTMENT PRECAUTIONS

Adjust the driver's seat so that the foot pedals, steering wheel and instrument panel controls are within easy reach of the driver.

CAUTION:

- **Adjustments should not be made while the vehicle is moving, as the seat may unexpectedly move and cause the driver to lose control of the vehicle.**
- **When adjusting the seat, be careful not to hit the seat against a passenger or luggage.**
- **After adjusting the seat position, try sliding it forward and backward to make sure it is locked in position.**
- **After adjusting the seatback, exert body pressure to make sure it is locked in position.**

ADJUSTING FRONT SEAT POSITION

Pull the lock release lever up. Then slide the seat to the desired position with slight body pressure and release the lever.

Do not place anything under the front seats. It might interfere with the seat-lock mechanism.

ADJUSTING FRONT SEATBACK ANGLE

To adjust the seatback angle, turn the knob. To change the angle further, pull the lock release lever, lean the seatback until it locks, then turn the knob for the desired angle.

ADJUSTING DRIVER'S SEAT CUSHION ANGLE

Turn the knob either way.

ADJUSTING DRIVER'S SEAT POWER LUMBER AND SIDE SUPPORTS

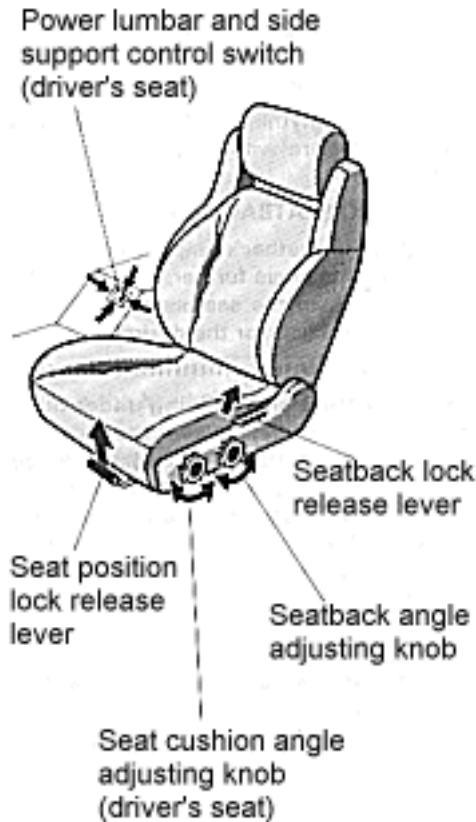

Move the control switch up or down to adjust the lumbar support and right or left to adjust the side supports. Releasing the switch will stop the move in that position. The ignition key must be in the "ON" position.

CAUTION:

To reduce the risk of sliding under the lap belt during a collision, avoid reclining the seatback any more than needed. The seat belts provide maximum protection when the driver and passenger are sitting up straight and well back in the seats. If you are reclined, the lap belt may slide past your hips and apply restraint forces directly to the abdomen. Therefore in the event of a frontal collision, the risk of personal injury may increase with increasing recline of the seatback.

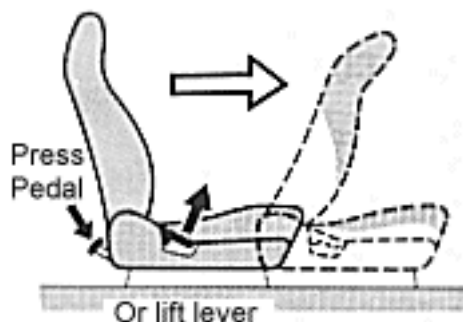

MOVING PASSENGER'S SEAT FOR REAR SEAT ENTRY Lift the seatback lock release lever or press the release pedal - the seat will automatically slide forward.

This allows passengers to get into or out of the rear seat easily. After passengers are in, list up on the seatback and push the seat rearward until it locks.

CAUTION

- **After putting back the seat, try pushing the seat forward and rearward to make sure that it is secured in place.**
 - **Never allow anyone to rest their foot on the press pedal while the vehicle is moving.**
-

OPERATION OF INSTRUMENTS AND CONTROLS



Fold-down Rear Seat

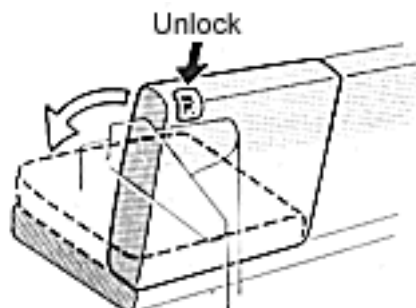

Unlock the seatback, and fold it down.

This will enlarge the luggage compartment as far as the front seatbacks. See [Luggage Stowage Precautions](#) for precautions to observe in loading luggage. If desired, each seatback may be folded separately.

CAUTION:

When returning the seatback to the up-right position:

- Make sure the seatbelts are not twisted or caught in the seatback and are arranged in their proper position ready for use.
- Make sure the seatback is securely locked by pushing forward and rearward on the top of the seatback.

OPERATION OF INSTRUMENTS AND CONTROLS



Headrests

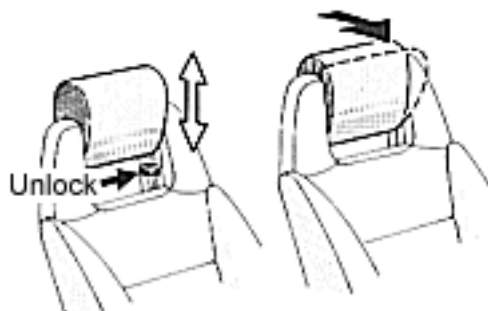

To raise the headrest, pull it up. To lower it, press the lock release button and push the headrest down. To move the headrest forward, pull on the top.

Pulling the top of the headrest as far as it can go will return it to the upright position.

The headrest is most effective when it is close to your head. Therefore, using a cushion on the seatback is not recommended.

CAUTION:

- **Adjust the top of the headrest so that it is closest to the top of your ears.**
- **After adjusting the headrest, make sure it is locked in position.**
- **Do not drive with the headrests removed.**

OPERATION OF INSTRUMENTS AND CONTROLS



Seat Heater Switches

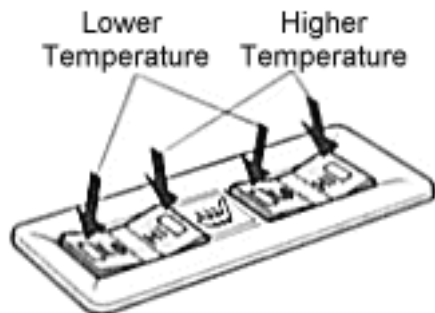

To turn on the seat heater, push the switch to "HI" (high heating temperature) or "LO" (low heating temperature).

The key must be in the "ON" position.

Pushing lightly on the opposite side will turn it off.

NOTICE:

To prevent the battery from being discharged, turn the switch on when the engine is running.

OPERATION OF INSTRUMENTS AND CONTROLS



Seat Belts

SEAT BELT PRECAUTIONS

Toyota recommends that the driver and passengers in the vehicle be properly restrained at all times with the seat belts provided. Failure to do so could increase the chance of injury and/or the severity of injury in accidents.

Child.

We recommend that the child sit in the rear seat and be restrained with the seat belt. If sitting in the front, do not allow the child to stand up or kneel on the seat, and your child should be restrained by the seat belt.

Baby or small child.

Child restraint systems are available. We recommend the use of a type which fits your vehicle. Before installation, always read the manufacturer's instruction.

Pregnant woman.

Toyota recommends the use of a seat belt. Ask your doctor for specific recommendations. The lap belt should be worn securely and as low as possible over the hips and not the waist.

Injured person.

Toyota recommends the use of a seat belt. Depending on the injury, however, first check with your doctor.

If seat belt regulations exist in the country where you reside, please contact your Toyota dealer for seat belt replacement or installation.

CAUTION:

When using the seat belts, observe the following:

- **Use the belt for only one person at a time. Do not use a single belt for two or more people - even children.**
- **After inserting the tab, make sure that the connection is secure and the belt is not twisted.**
- **Avoid reclining the seatbacks too much. The seat belts provide maximum protection when the seatbacks are in the upright position. (See the [seat adjustment instructions](#).)**
- **Be careful not to damage the belt webbing or hardware, and take care that they**

do not get caught or pinched in the seat or doors.

- **Inspect the belt system periodically. Check for cuts, frays and loose parts. Damaged parts should be replaced. Do not disassemble or modify the system.**
- **Keep the belts clean and dry. If they need cleaning, use a mild soap solution or lukewarm water. Never use bleach, dye or abrasive cleaners - they may severely weaken the belts.**
- **Replace the belt assembly if it has been used in a severe impact. The entire assembly should be replaced even if damage is not obvious.**

3-POINT TYPE



Adjust the seat as needed and sit up straight and well back in the seat. To fasten your belt, pull it out of the retractor and insert it into the buckle.

You will hear a click when the tab locks into the buckle.

The seat belt length automatically adjusts to your size and the seat position.

The retractor will lock the belt during a sudden stop or on impact. It also may lock if you lean forward too quickly. A slow, easy motion will allow the belt to extend, and you can move around freely.

If the seat belt can not be pulled out of the retractor, firmly pull the belt and release it. You will then be able to smoothly pull the belt out of the retractor.

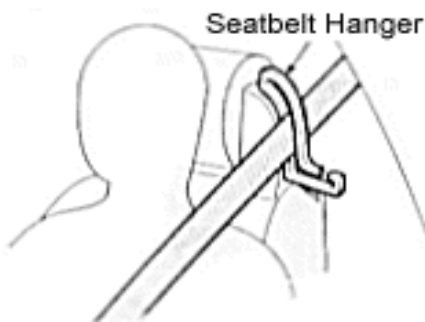

Seats with a seat belt hanger - Pass the shoulder belt through the seat belt hanger.



Adjust the position of the lap and shoulder belts.

Position the lap belt as low as possible on your hips - not on your waist, then adjust it to a snug fit by pulling the shoulder portion upward through the latch plate.

Keep as low on hip bone as possible

CAUTION

- **High-positioned lap belts and loose-fitting shoulder belts both could increase the chance of injury due to sliding under the lap belt during an accident.**
- **For your safety, do not place the shoulder belt under your arm.**

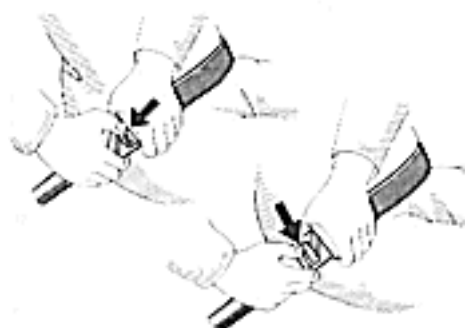

To release the belt, press the buckle-release button and allow the belt to retract.

On seats with a belt hanger, you need not remove the belt from the belt hanger except when the passengers get into or out of the rear seat. If the belt does not retract smoothly, pull it out and check for kinks or twists. Then make sure that it remains untwisted as it retracts.

2-POINT TYPE

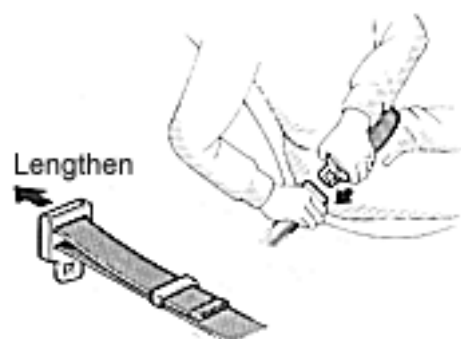

Sit up straight and well back in the seat. To fasten your belt, insert the tab into the buckle.

You will hear a click when the tab locks into the buckle. If the belt is not long enough for you, hold the tab at a right angle to the belt and pull on the tab.

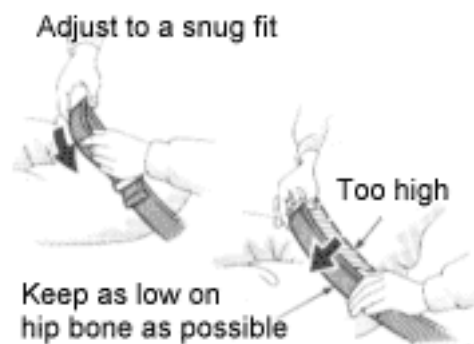

Remove excess length of the belt and adjust the belt position.

To shorten the belt, pull the free end of the belt.

Position the lap belt as low as possible on your hips - not your waist, then adjust it to a snug fit.

CAUTION:

High-positioned lap belts could increase the chance of injury due to sliding under the lap belt during an accident.



To release the belt, press the buckle-release button.

OPERATION OF INSTRUMENTS AND CONTROLS

Steering Wheel



TILT STEERING WHEEL

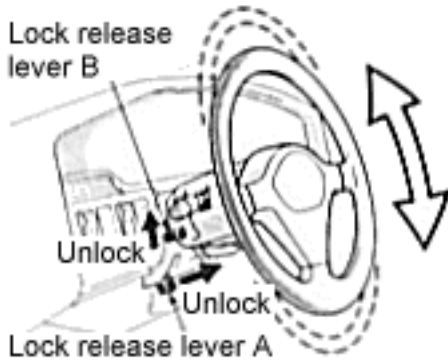

To change the steering wheel angle, pull up the lock release lever A, tilt the steering wheel to the desired angle and release the lever. For easy entry and exit to the seat, the steering wheel can be swung up by pulling the lock release lever B.

After entering the seat, pull the steering wheel down. It will return to the previous position.

TELESCOPIC STEERING COLUMN

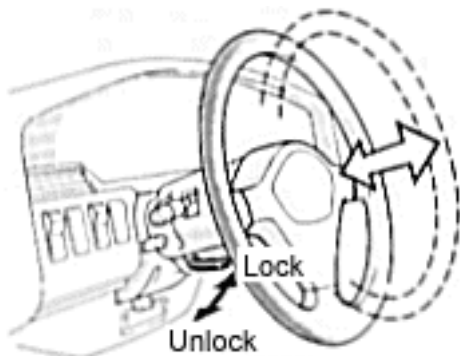

To adjust the steering column length, push down the lock release lever, push or pull the steering wheel to the desired position, and pull the lever fully up to its original position.

CAUTION

- The steering wheel should not be adjusted while the vehicle is moving.
- After adjusting the steering wheel, try moving it up and down or forward and rearward to make sure it is locked in position.

OPERATION OF INSTRUMENTS AND CONTROLS



Mirrors

POWER REAR VIEW MIRROR CONTROL

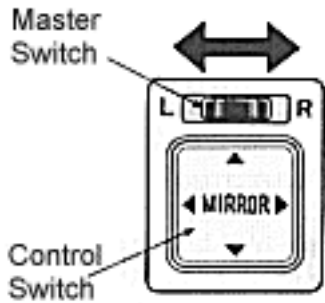

To adjust a power rear view mirror, first place the master switch at "R" (right) OR "L" (left) depending on which mirror needs adjusting, then push the control switch in the desired direction.

If the engine is not running, the key must be in the "ACC" position.

NOTICE:

If ice should jam the mirror, do not operate the control or scrape the mirror face. Use a spray de-icer to free the mirror.

FOLDING REAR VIEW MIRRORS

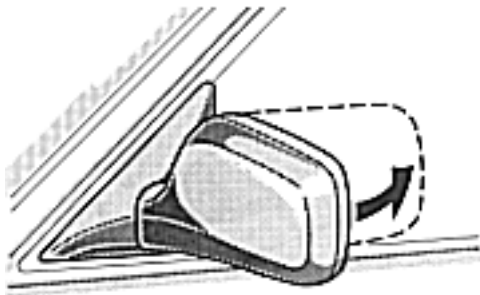

To fold the rear view mirror, push backward.

The rear view mirrors can be folded backward for parking in restricted areas.

ANTI-GLARE INSIDE REAR VIEW MIRROR



Pull the lever toward you to reduce the glare from the headlights of the vehicle behind you during night driving.

Before adjusting the mirror to the position with most clarity, push the day-night change lever away from you (daylight driving position).

Remember that by reducing glare you also lose some rear view clarity.

OPERATION OF INSTRUMENTS AND CONTROLS



Lights, Wipers and Defogger

- Headlight and turn signal switch
- Headlight beam level control switch
- Emergency flasher switch
- Instrument panel light control
- Front fog light switch
- Rear fog light switch
- Interior lights
- Ignition switch and step lights
- Luggage compartment light
- Windshield wiper and washer switch
- Rear window wiper and washer switch
- Headlight cleaner switch
- Rear window defogger switch

OPERATION OF INSTRUMENTS AND CONTROLS



Headlight and Turn Signal Switch

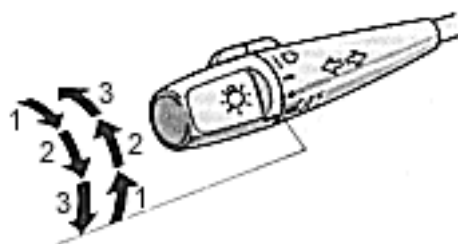

To turn the lights on, twist the knob on the end of the lever.

However, on some models, front fog lights and all lights below but the headlights also turn on when the engine is started with the headlight switch off or at the first click-stop position.

Forward -

FIRST CLICKSTOP: No operation.

SECOND CLICKSTOP: Only the parking, tail, license plate and instrument panel lights turn on.

THIRD CLICKSTOP: The headlights also turn on.

Backward -

FIRST CLICKSTOP: Only the headlights turn off (Headlights stay in the raised position).

SECOND CLICKSTOP: All other lights turn off (Headlights stay in the raised position).

THIRD CLICKSTOP: The headlights retract.

On vehicles sold in the United Kingdom and Germany, adjust the headlight beam level before turning on the headlights. (See [Headlight Beam Level Control Switch](#).)

The headlights automatically turn off when the ignition is turned off. To turn them on again, turn the key to the "ON" position or actuate the headlight switch. The buzzer will remind you to turn the lights off when the driver's door is opened if the ignition switch is turned to the "LOCK" position with the headlight switch on.

If the headlight retractable system does not operate, see Part 4 for emergency information.

NOTICE:

- To prevent the battery from being discharged, do not leave the lights on for a long period when the engine is not running.
- If there is a possibility that the retractable system could freeze, keep the headlights in the raised position.
- If the headlights are frozen, do not attempt to raise or retract them but wait until the system thaws out.

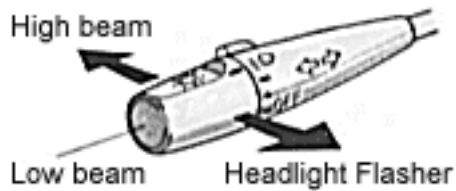

For high beam, push the lever away from you. Pull it toward you for low beam. For the headlight flasher, pull the lever all the way back, and release.

A blue light on the dashboard indicates high beam is on.

On vehicles sold in Austria, the front fog lights will also flash when the headlight flasher is used.

The headlight flasher works even when the headlight switch is off.

If the switch is off, hold the lever for a second before releasing it. The headlights will rise and come on. They will automatically retract after the lever is release.

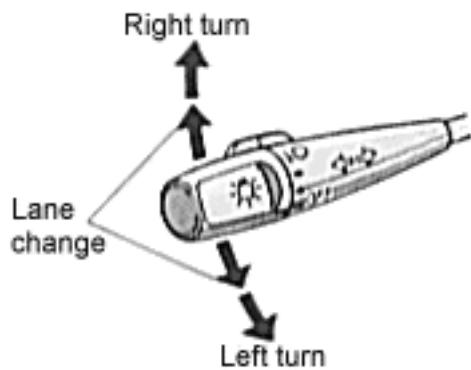

For signaling turns, move the lever up or down in the conventional manner.

The key must be in the "ON" position.

The turn signal is self-cancelling after a turn, but after a lane change, you may have to cancel it by hand. You can also signal a lane change by moving the turn signal lever partway and holding it there. If the green dashboard light flashes faster than normal, it indicates that the front or rear turn signal bulb has burned out.

OPERATION OF INSTRUMENTS AND CONTROLS



Headlight Beam Level Control Switch



To adjust the headlight beam level, turn the switch.

Listed below are examples of proper switch settings. For loading conditions other than those listed, adjust the switch position so that the beam level is the same as the one obtained according to the list when only the driver is in the vehicle. The higher the number of the switch position, the lower the headlight beam level.

Always keep the headlight beam at the proper level, or your headlights may dazzle other road users.

Loading condition and switch position

United Kingdom

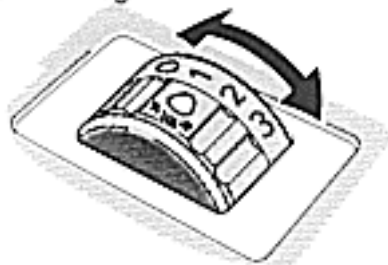

Driver only	0
Driver + front passenger	0
Full passengers (including driver)	1
Full passengers (including driver) & full luggage loading	2
Driver & full luggage loading	3

OPERATION OF INSTRUMENTS AND CONTROLS



Emergency Flasher Switch

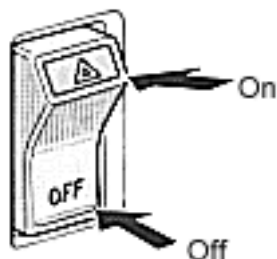

To turn on the emergency flashers, push the switch.

All the turn signal lights will flash.

Turn on the emergency flashers to warn other drivers if your vehicle must be stopped where it might be a traffic hazard.

Always pull as far off the road as possible.

The turn signal light switch will not work when the emergency flashers are in operation.

NOTICE:

To prevent the battery from being discharged, do not leave the switch on longer than necessary when the engine is not running.

OPERATION OF INSTRUMENTS AND CONTROLS



Instrument Panel Light Control

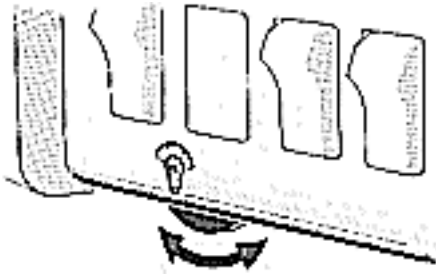

To adjust the brightness of the instrument panel lights, turn the knob.

OPERATION OF INSTRUMENTS AND CONTROLS



Fog Lights

Front Fog Light Switch (except Austria)

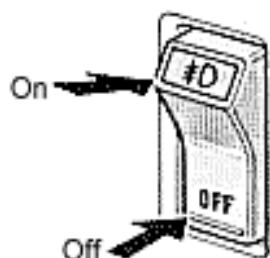

To turn on the front fog lights, push the switch. They will come on when the headlights and/or tail lights are turned on.

On vehicles sold in Switzerland, the front fog lights will be off when the headlights are on high beam.

Rear Fog Light Switch

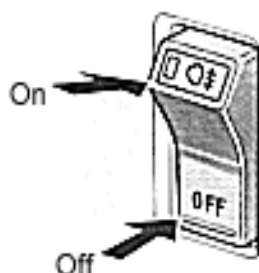

To turn on the rear fog lights, push the switch. They will come on when either the headlights or front fog lights are turned on.

OPERATION OF INSTRUMENTS AND CONTROLS



Cabin Lights

Interior Lights

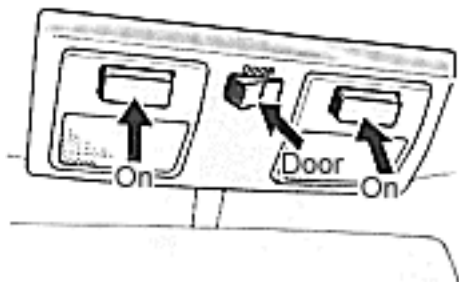

To turn on the interior light, push the switch

With the DOOR switch pushed in, both lights come on when either of the side doors is opened.

Ignition Switch and Step Lights

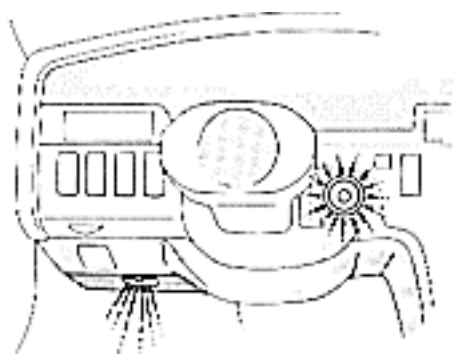

For easy access to the ignition switch, the ignition switch and step lights are designed to come on when either of the side doors is opened.

The lights remain on for a certain time after both doors are closed.

Luggage Compartment Light

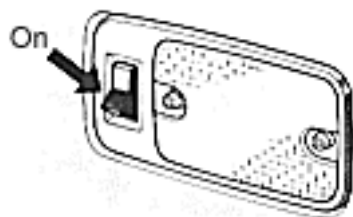

To turn the luggage compartment light on, open the back door and push the switch. Closing the back door will turn the light off.



OPERATION OF INSTRUMENTS AND CONTROLS

Washer and Wiper Controls

Windshield wiper and washer switch

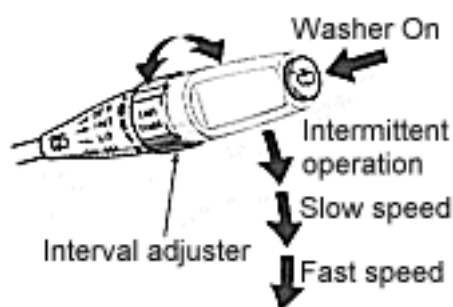

To turn the wipers on, move the lever. To make the washer squirt, push the button on the end of the lever.

The key must be in the "ON" position.

The wipers will operate at intervals when the lever is in the "INT" position. With the lever in this position, the wipers can be adjusted to operate at intervals of 3 to 12 seconds depending on the interval adjuster setting

between "S" and "F".

Also the wipers will automatically operate a couple of times after the washer squirts even with the lever in the "OFF" position.

If the washer does not work, check to see whether the washer tank is empty. For information on adding washer fluid, see [Adding Washer Fluid](#).

In cold weather, warm the windshield with the defroster before using the washer. This will help prevent icing, which could block your vision.

NOTICE:

Do not operate the wipers if the windshield is dry. It may scratch the glass.

Rear window wiper and washer switch

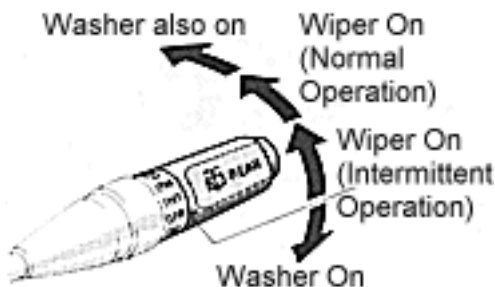

To turn the rear wiper and washer on, twist the knob at the end of the lever.

The key must be in the "ON" position.

The wiper will operate at intervals when the knob is in the "INT" position.

The washer squirts at the two marked knob positions. The knob will automatically return from these positions when it is released.

If the washer does not work, check to see whether the washer tank is empty. For information on adding washer fluid, see [Adding Washer Fluid](#).

NOTICE:

Do not operate the rear wiper if the rear window is dry. It may scratch the glass.

Headlight cleaner switch

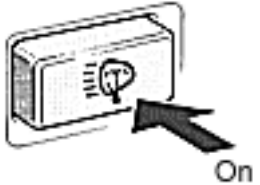

To spray fluid on the headlights, turn the headlights on and push the switch.

The key must be in the "ON" position.

Check the fluid level of the see-through headlight cleaner tank every so often.

Use washer fluid for replenishment. For information on adding fluid, see "Adding washer fluid" in Chapter 7-3.

NOTICE:

Do not turn the headlight cleaner on with the tank empty. It may cause the cleaner motor to overheat.

OPERATION OF INSTRUMENTS AND CONTROLS



Rear Window Defogger Switch

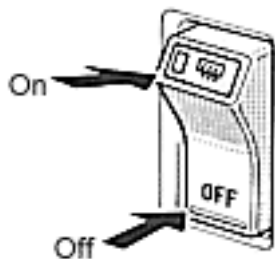

To defog or defrost the rear window, push the switch.

The key must be in the "ON" position.

The thin heater wires on the inside of the rear window and heater panels in the outside rear view mirrors will quickly clear the surfaces. An indicator light will illuminate to indicate the defogger is operating. Keep your hands off the mirror faces when the switch is on.

When the surface has cleared, turn the defogger off. Continuous use may cause the battery to discharge, especially during stop-and-go driving. The defogger is not designed for drying rain water or for melting snow.

The system will automatically shut off after the defogger has operated about 15 minutes. If further defrosting or defogging is desired, simply actuate the switch again.

If the outside rear view mirrors are heavily coated with ice, use a spray de-icer before operating the switch.

NOTICE:

When cleaning the inside of the rear window, be careful not to scratch or damage the heater wires.

OPERATION OF INSTRUMENTS AND CONTROLS



Gauges, Meters and Warning Lights

- [Fuel gauge](#)
- [Engine temperature gauge](#)
- [Oil pressure gauge](#)
- [Turbo boost gauge](#)
- [Voltmeter](#)
- [Tachometer](#)
- [Odometer and trip meter](#)
- [Warning lights and buzzers](#)
- [Econodrive monitor](#)

OPERATION OF INSTRUMENTS AND CONTROLS

Gauges



Fuel Gauge

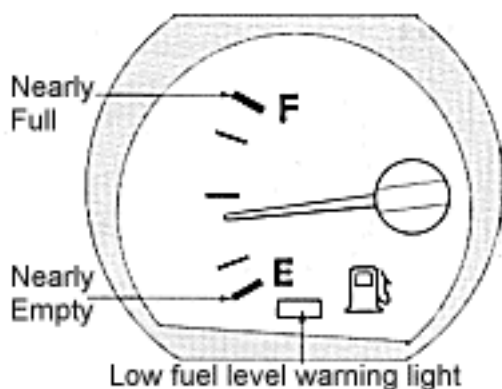

The gauge works when the ignition switch is on and indicates approximate quantity of fuel remaining in the tank.

It is a good idea to keep the tank over 1/4 full.

This fuel gauge has a non-return type needle. Therefore the needle will remain at the indicated fuel level position regardless of the position of the ignition switch.

Do not drive with the fuel level below the "E" or with the low fuel level warning light on. It may cause engine misfire and damage to the catalytic convertor.

Engine Temperature Gauge

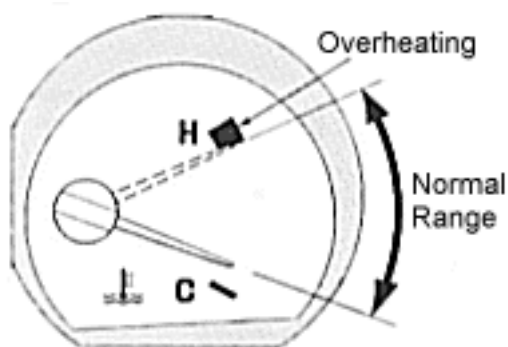

The gauge indicates the engine coolant temperature when the ignition switch is on. The engine operating temperature will vary with changes in weather and engine load.

If the needle points to the red zone or high, stop your vehicle and allow it to cool.

Your vehicle may overheat during severe operating conditions, such as

- Driving up a long hill on a hot day.
- Reducing speed or stopping after high speed driving
- Idling for a long period with the air conditioner on in stop-and-go traffic.
- Towing a trailer.

NOTICE:

Do not continue driving with an overheated engine. See [If Your Vehicle Overheats](#).

Oil Pressure Gauge

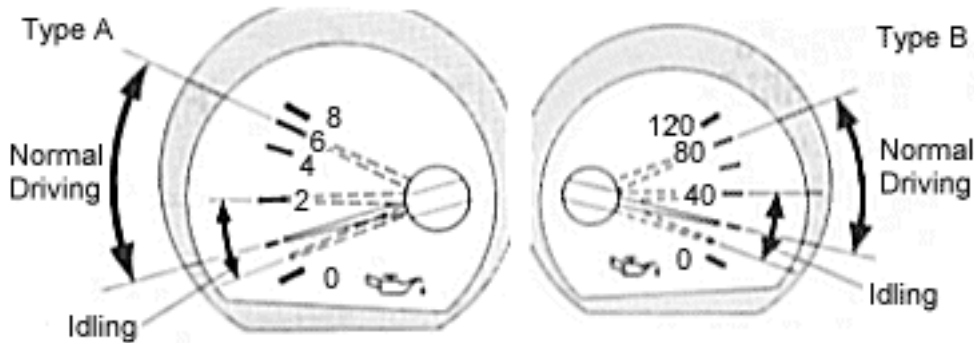

The oil pressure gauge indicates engine oil pressure when the ignition is on. Check it while driving to make sure that the needle is in the proper range.

If the oil pressure should stay below the normal range, pull off the road to a safe place and stop the engine

immediately. Call a Toyota dealer or qualified repair shop for assistance.

Oil pressure may not build up when the oil level is too low. The oil pressure gauge is not designed to indicate oil level, and the oil level must be checked using the level dipstick.

NOTICE:

Do not drive the vehicle with the oil pressure below the normal range until the cause is fixed - It may ruin the engine.

Turbo Boost Pressure Gauge (7M-GTE engine)

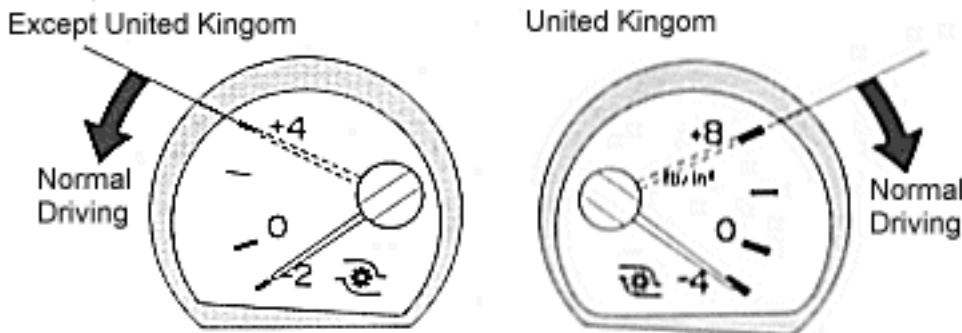

The gauge indicates the boost pressure in the turbocharging system.

NOTICE:

Avoid continuous pressures over normal range. It may cause engine damage.

OPERATION OF INSTRUMENTS AND CONTROLS



Meters

Voltmeter

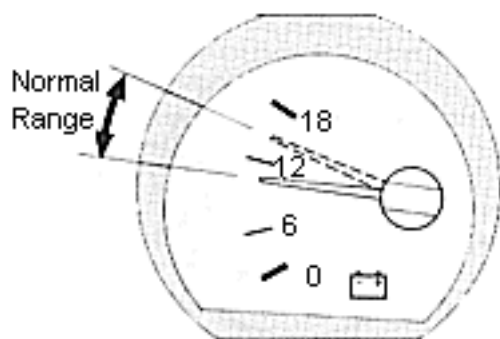

The voltmeter tells whether the battery is charged or discharged. Check it while the engine is running - the needle should always indicate as shown.

If the needle reads below or above the normal range while the engine is running. It indicates the charging system needs immediate repair.

However, it is normal for the needle to drop below the normal range during engine starting.

Tachometer

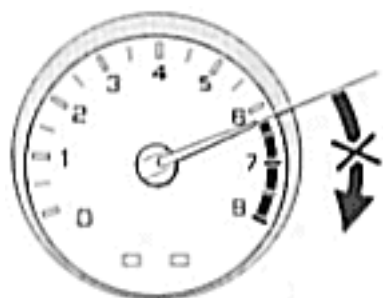

Do not run into red zone

The tachometer indicates engine speed in thousands of rpm (revolutions per minute). Use it while driving to select correct shift points and to prevent engine lugging and overrevving.

Driving with the engine running too fast causes excessive engine wear and poor fuel economy. Remember, in most cases the slower the engine speed, the greater the fuel economy.

NOTICE:

Do not run the needle into the red zone. This may cause severe engine damage.

Speedometer, Odometer and Trip meter

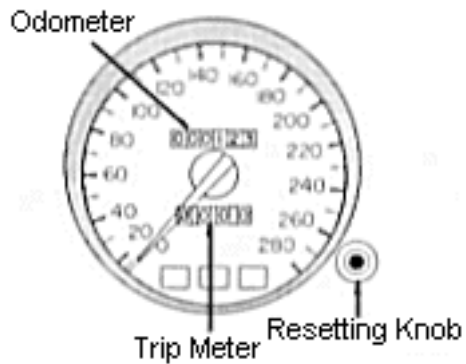

The odometer records the total distance the vehicle has been driven. The trip meter may be set to zero to record the distance on each trip. To set the trip, press the knob in and release it.

The black digits in white indicate tenths of kilometers or miles.

OPERATION OF INSTRUMENTS AND CONTROLS



Warning Lights



Brake System Warning light

This light has the following functions:

- **Parking brake reminder.**

If this light is on, make sure the parking brake is fully released. The light should go off.

- **Stop light failure warning. (except germany)**

If the light comes on when the brake pedal is depressed, it indicates one or more stop lights has burned out.

Have defective bulbs replaced as soon as possible.

- **Low brake fluid level warning.**

If this light comes on and stays on while you are driving, slow down and pull off the road. Then stop the vehicle carefully. There may be a problem somewhere in the brake system. Check the fluid level of the see-through reservoir.

To make sure that the parking brake is fully release.

If the brake fluid level is low ...

At a safe place, test your brakes by starting and stopping.

- If you judge that the brakes still work adequately, drive cautiously to your nearest dealer or shop for repairs.
- If the brakes are not working, have the vehicle towed in for repairs. ([Towing Information](#))

CAUTION:

Continued normal driving with low brake fluid level is dangerous.

If the brake fluid level is correct ...

Have the warning system checked by your Toyota dealer.

Discharge Warning Light

This light warns that the battery is being discharged.

If it comes on while you are driving, there is a problem somewhere in the charging system. The engine ignition will continue to operate, however, until the battery is discharged. Turn off the air conditioner, blower, radio etc. and drive directly to the nearest Toyota dealer or repair shop.

Engine System Warning Light

This light warns that there is a problem somewhere in your engine electrical system. If it comes on while you are driving, have your vehicle checked/repared by your Toyota dealer as soon as possible.

Low Fuel Level Warning Light

This light comes on when the fuel level in the tank becomes nearly empty. Fill up the tank as soon as possible.

Low Engine Oil Warning Light

The light warns that the engine oil is too low. Add oil as soon as possible. (For instructions, see [Checking the Engine Oil Level](#))

NOTICE:

Continued driving with low engine oil will cause the engine to be damaged.

Anti-lock Brake System Warning Light

This light warns that there is a problem somewhere in your anti-lock brake system. When the anti-lock brake system warning light is on (and the brake system warning light is off), the brake system operates conventionally but without anti-lock function.

If it comes on while you are driving, have your vehicle checked by your Toyota dealer as soon as possible.

Open Door Warning Light

This light remains on until all the side doors are completely closed.

Rear Bulb Failure Warning Light

If this light comes on when the headlight switch is turned on (at the second or third clickstop), it indicates that one or more of the tail lights are burned out (all models) or the "TAIL (RH)" or "TAIL (LH)" fuse has blown out (Germany only).

Have defective bulbs and blown fuses replaced as soon as possible.

Engine Temperature Warning Light and Buzzer

The light and buzzer operate at high speeds to warn that the engine is almost overheating.

If they come on, drive at reduced speeds until they go off. After the light and buzzer go off, you may drive at

high speeds again.

NOTICE:

Continued high speed driving with the light and buzzer on could result in engine overheating.

[top](#)

Light Reminder Buzzer

This buzzer will sound when the driver's door is opened if the ignition switch is turned to the "LOCK" position with the headlight switch on. Removing the key will not stop the buzzer as long as the headlight switch is on.

[top](#)

CHECKING WARNING LIGHTS (except the low fuel level warning light)

1. Apply the parking brake.
2. Open one of the side doors. The open door warning light should come on.
3. Close the side door. The open door warning light should go off.
4. Turn the ignition key to "ON", but do not start the engine.
All the warning lights except the open door warning light should come on. The anti-lock brake system warning light goes off after 3 seconds.

If any warning light or buzzer does not function as described above, either the bulb is burned out or the circuit is in need of repair. Have it checked by your Toyota dealer as soon as possible.

[top](#)

OPERATION OF INSTRUMENTS AND CONTROLS



Econodrive Monitor

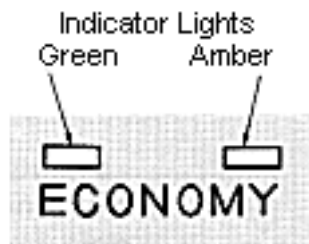

The econodrive monitor keeps you informed of your fuel economy by the color. For best fuel economy, try to keep it in the green.

An amber color indicates increased fuel consumption. Accelerating slowly and smoothly will help keep it in the green.

OPERATION OF INSTRUMENTS AND CONTROLS



Ignition switch, Transmission and Parking Brake

- [Ignition switch with steering lock](#)
- [Automatic transmission](#)
- [Manual transmission](#)
- [Parking brake](#)
- [Cruise control](#)

OPERATION OF INSTRUMENTS AND CONTROLS



Ignition switch with steering lock

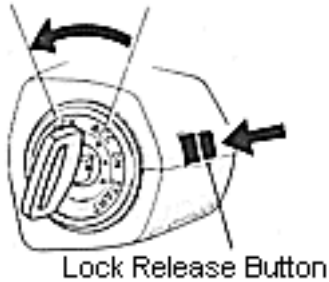

- "START" - Starter motor on. The key will return to the "ON" position when release.

For starting tips see Part 3.

- "ON" - engine on and all accessories on

This is the normal driving position.

- "ACC" - Accessories such as the radio operate, but the engine is off.
- "LOCK" - Engine is off and the steering wheel is locked. The key can be removed only at this position.

You must press in the lock release button to turn the key to the "LOCK" position.

When starting the engine, the key may seem stuck at the "LOCK" position. To free it, first be sure the key is pushed all the way in, and then rock the steering wheel slightly while turning the key gently.

CAUTION:

Never remove the key when the vehicle is moving, as this will lock the steering wheel and result in loss of steering control.

NOTICE:

Do not leave the key in the "ON" position if the engine is not running. The battery will discharge and the ignition could be damaged.

OPERATION OF INSTRUMENTS AND CONTROLS



Automatic Transmission

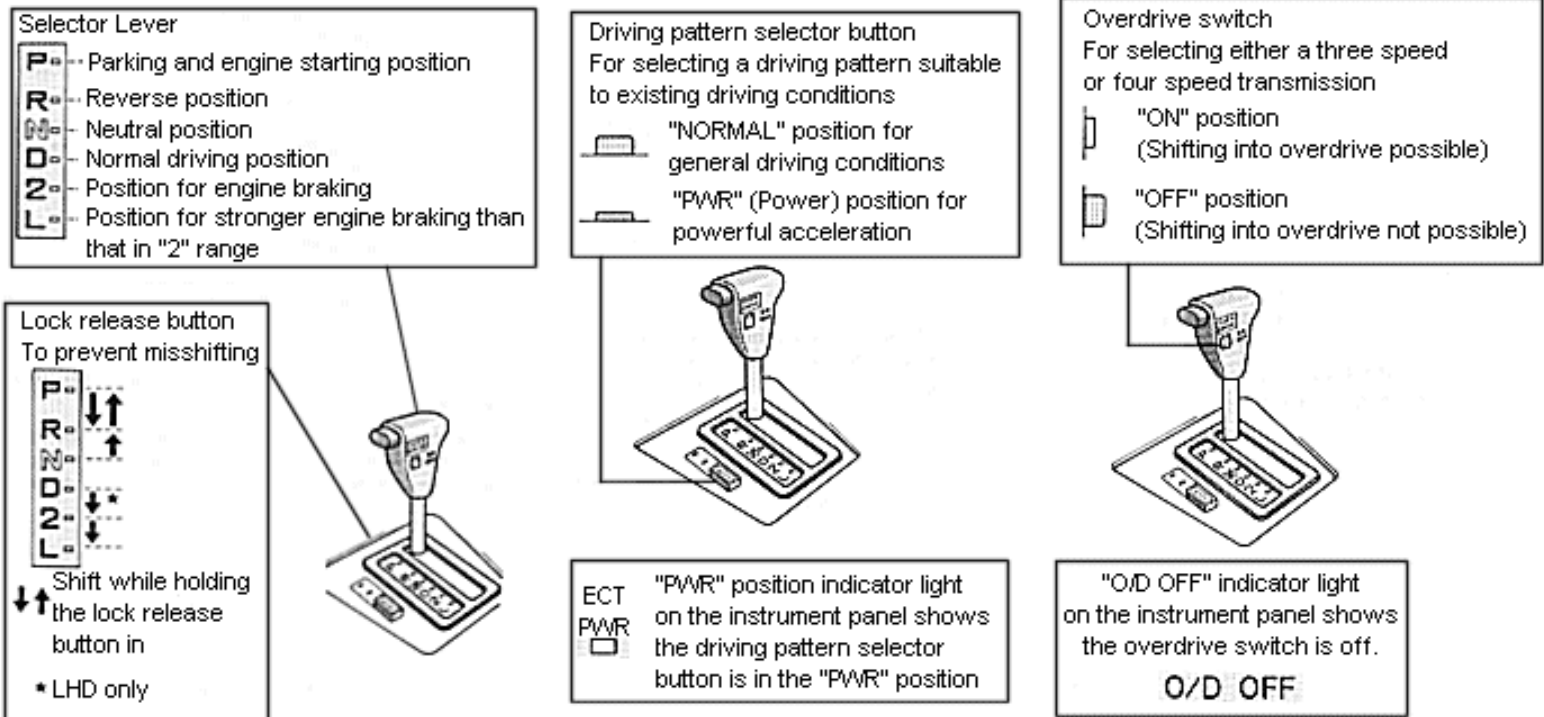

(a) Normal driving

1. Start the engine as instructed in "How to start the engine" in Part 3. The transmission must be in "P" or "N". The engine will not start in "R", "2", "L" or "D" range even if the key is turned.
2. Set the driving pattern selector button to the "NORM" position. Your transmission is fitted with a driving pattern selector button which allows you to select either "NORM" or "PWR" to suit your driving condition. For ordinary driving, Toyota recommends that you use the "NORM" position to improve fuel economy. For powerful acceleration, use the "PWR" position. In the "PWR" position, the "PWR" position indicator light is on and the transmission is shifted up and down at a higher vehicle speed than in the "NORM" position.
3. Push the overdrive switch to set it on. Always turn the overdrive switch on for better fuel economy and quieter driving (See [\(b\) Using engine braking](#) and [\(f\) Good driving practice](#) for exceptions.)
4. With your foot holding down the brake pedal, shift the selector lever to "D".

CAUTION:

Never put your foot on the accelerator pedal while shifting.

5. Release the parking brake and brake pedal. Depress the accelerator pedal slowly for smooth starting. The vehicle will start in the first gear and automatically shift to the second, third and overdrive gears according to the vehicle speed. However, while the engine coolant temperature is low and the vehicle is travelling at low speed, the transmission will not be shifted into the third gear and overdrive gear even with the overdrive switch on. In "D" range, the automatic transmission system will select the most suitable gear for the running conditions such as hill climbing, hard towing, etc. If you need to accelerate rapidly while driving, push the accelerator pedal all the way to the floor. The transmission will

automatically downshift to the third, second or first gear, according to the vehicle speed.
If engine braking is needed, such as in descending a long hill, see [\(b\) Using engine braking](#).

(b) Using engine braking

To use the braking power of the engine, downshift the transmission in the way described below:

- Turn off the overdrive switch. (This is effective only when you are driving in the "D" range.) The "O/D OFF" indicator light will come on and the transmission will downshift to the third gear.
- Shift into the "2" range. The transmission will downshift to the second gear when the vehicle speed is or becomes lower than the speed listed below and more powerful engine braking will be obtained.
- Shift into the "L" range. the transmission will downshift to the first gear when the vehicle speed is or becomes lower than the speed listed below and maximum engine braking will be applied.

7M-GE engine.

"2" 117 km/h (73 mph)

"L" 64 km/h (40 mph)

7M-GTE engine.

"2" 126 km/h (78 mph)

"L" 69 km/h (43 mph)

CAUTION:

Be careful when downshifting on a slippery surface. Abrupt shifting could cause the vehicle to spin or skid.

(c) Using the "2" and "L" ranges

The "2" and "L" ranges are used for strong engine braking as described previously.

With the selector lever in "2" or "L", you can start the vehicle in motion as with the lever in "D".

With the selector lever in "2", the vehicle will start in the first gear and automatically shift to the second gear.

With the selector lever in "L", the transmission is engaged in the first gear.

NOTICE:

Be careful not to overrev the engine. Watch the tachometer to keep engine rpm from going into the red zone. The maximum allowable speed (approximate) for each range is given below for your reference:

7M-GE engine.

"2" 117 km/h (73 mph)

"L" 64 km/h (40 mph)

7M-GTE engine.

"2" 126 km/h (78 mph)

"L" 69 km/h (43 mph)

Do not continue hill climbing or hard towing for a long time in the "2" or "L" range. It may cause severe automatic transmission damage from overheating. To prevent such damage, "D" range should be used in the climbing or hard towing.

(d) Backing up

1. Bring the vehicle to a complete stop.
 2. Pull the parking brake lever up fully to securely apply the parking brake
 3. With the brake pedal held down with your foot, shift the selector lever to the "R" range.
-

(e) Parking

1. Bring the vehicle to a complete stop.
2. Pull the parking brake lever up fully to securely apply the parking brake
3. With the brake pedal held down with your foot, shift the selector lever to the "P" range.

CAUTION:

While the vehicle is in motion, never attempt to move the selector lever into "P" under any circumstances.

Serious mechanical damage and loss of vehicle control may result.

(f) Good driving practice

- If the transmission is repeatedly upshifted and downshifted between the third and overdrive gears when climbing a gentle slope, it is suggested that the overdrive switch be turned off. Be sure to turn the switch on immediately afterward.
- When towing a trailer, in order to maintain engine braking efficiency, do not use overdrive.

CAUTION:

Always keep your foot on the brake pedal while stopping with the engine running. This prevents the vehicle from creeping.

NOTICE:

Do not hold the vehicle on an upgrade with the accelerator pedal. It can cause the transmission to overheat. Always use the brake pedal or parking brake.

(g) If the "O/D OFF" indicator light flashes

Contact your Toyota dealer as soon as possible. There may be a trouble in the transmission system.

OPERATION OF INSTRUMENTS AND CONTROLS



Manual Transmission

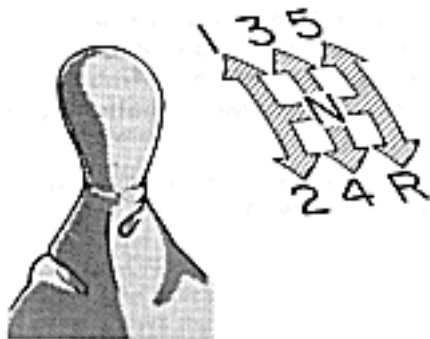

The shift pattern is conventional as shown.

Press the clutch pedal down fully while shifting, and then release it slowly. Do not rest your foot on the pedal while driving, because it will cause a clutch trouble. And do not use the clutch to hold the vehicle when stopped on an uphill grade - use the parking brake.

Recommended shifting speeds.

The transmission is fully synchronized and upshifting or downshifting is easy.

For the best compromise between fuel economy and vehicle performance, you should upshift or downshift at approximately the following speeds:

Upshifting

gear	km/h (mph)
1 to 2	24 (15)
2 to 3	40 (25)
3 to 4	65 (40)
4 to 5	72 (45)

Downshifting

gear	km/h (mph)
2 to 1	20 (12)
3 to 2	30 (19)
4 to 3	40 (25)
5 to 4	50 (31)

Upshifting too soon or downshifting too late will cause lugging and, possibly, pinging. Regularly revving the engine to maximum speed in each gear will cause excessive engine wear and high fuel consumption.

Maximum allowable speeds

To get on a highway or to pass slower traffic, maximum acceleration may be necessary. Make sure you observe the following maximum allowable speeds in each gear:

7M-GE engine

gear	km/h (mph)
1	58 (36)

7M-GTE engine

gear	km/h (mph)
1	62 (39)

2	101 (63)	2	103 (64)
3	150 (93)	3	154 (96)

NOTICE

Do not downshift if you are going faster than the maximum allowable speed for the next lower gear.

Good driving practice

- If it is difficult to shift into reverse, put the transmission in neutral, release the clutch pedal momentarily, and then try again.
- When towing a trailer, in order to maintain engine braking efficiency, do not use the fifth gear.

CAUTION:

Be careful when downshifting on a slippery surface. Abrupt shifting could cause the vehicle to spin or skid.

NOTICE:

Make sure the vehicle is completely stopped before shifting into reverse.

OPERATION OF INSTRUMENTS AND CONTROLS



Parking brake

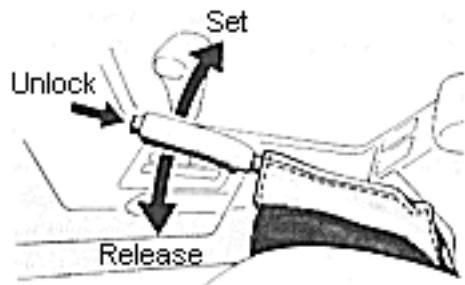

To set: Pull up the lever.

To release: Pull up slightly, press the thumb button, and lower.

Before leaving your vehicle, firmly apply the parking brake.

CAUTION:

Before driving, be sure the parking brake is fully released and the parking brake reminder light is off.

OPERATION OF INSTRUMENTS AND CONTROLS



Cruise control

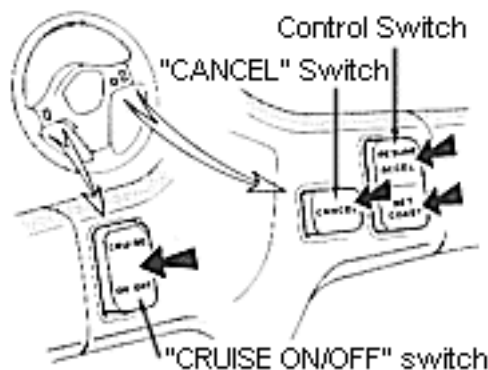

The cruise control allows you to cruise the vehicle at a desired speed over 40 km/h (25mph) even with your foot off the accelerator pedal.

Your cruising speed can be maintained up or down grades within the limits of engine performance, although a slight speed change may occur when driving up or down the grades. On steeper hills, a greater speed change will occur so it is better to drive without the cruise control.

CAUTION:

To help maintain maximum control of your vehicle, do not use the cruise control when driving in heavy or varying traffic, or on slippery (rainy, icy or snow covered) or winding roads.

TURNING ON THE SYSTEM

To operate the cruise control, push the "CRUISE ON/OFF" switch. This turns the system on. The indicator light in the instrument panel shows that you can now set the vehicle at a desired cruising speed. Another push on the switch will turn the system completely off.

CAUTION:

To avoid accidental cruise control engagement, keep the "CRUISE ON/OFF" switch off when not using the cruise control.

SETTING AT A DESIRED SPEED

Bring the vehicle to a desired speed, push the control switch on the "SET (COAST)" side and release it. This sets the vehicle at that speed. Now you may take your foot off the accelerator pedal. If you need acceleration - for example, when passing - depress the accelerator pedal enough for the vehicle to exceed the set speed. When you release it, the vehicle will return to the speed set prior to the acceleration.

CAUTION:(for manual transmission)

While driving with the cruise control on, do not shift to neutral without depressing the clutch pedal, as this may cause engine racing or overrevving.

CANCELLING THE PRESET SPEED

You can cancel the preset speed by:

- a. depressing the brake pedal.
- b. depressing the clutch pedal (manual transmission).
- c. placing the selector lever in "N" (automatic transmission).
- d. pushing the "CANCEL" switch.

If the vehicle speed falls below 40 km/h (25 mph), the preset speed will automatically cancel out.

If the vehicle speed drops 16km/h (10 mph) below the preset speed, the preset speed will also automatically cancel out.

If the preset speed automatically cancels out other than for the above cases or, if the indicator light flashes several times, the cruise control may be malfunctioning. In such cases, have your vehicle checked by your Toyota dealer at the earliest opportunity.

RESETTING AT A FASTER SPEED

Push the control switch on the "ACCEL (RESUME)" side and hold it. Release the switch when the desired speed is attained. While the switch is held, the vehicle will gradually gain speed.

However, a faster way to reset is to accelerate the vehicle and then push the control switch on the "SET (COAST)" side.

RESETTING AT A SLOWER SPEED

Push the control switch on the "COAST (SET)" side and hold it. Release the switch when the desired speed is attained. While the switch is held, the vehicle speed will gradually decrease.

However, a faster way to reset is to depress the brake pedal and then push the control switch on the "SET (COAST)" side.

RESUMING THE PRESET SPEED

Push the control switch on the "RESUME (ACCEL)" side. The vehicle will resume the speed set prior to cancellation unless the vehicle slows down to less than 40 km/h (25 mph) or to a speed 16 km/h (10 mph) below the preset speed.

OPERATION OF INSTRUMENTS AND CONTROLS



Car audio and Air conditioning system

- [Car audio operating tips](#)
- [AM-FM radio with electronic tuner and cassette tape player](#)
- [Automatic air conditioner controls](#)
- [Heater controls](#)
- [Dashboard vents](#)

OPERATION OF INSTRUMENTS AND CONTROLS



Car audio operating tips

You can listen to the car audio when the ignition key is at "ON" or "ACC". However, if the engine is not running, the key must be in the "ACC" position.

RADIO

FM broadcasts have a range of about 40 km or 25 miles. When driving away from a station you may have to fine-tune your radio and turn up the volume as the station gets weaker. Because FM uses a line-of-sight signal, tall buildings or hills may sometimes block reception. These are all normal characteristics of FM reception and do not indicate any problem with radio itself.

The antenna automatically extends to its full height when the radio and ignition are turned on, and retracts when either is turned off.

Before extending the antenna, confirm that no one is close enough to get pushed.

NOTICE:

To prevent damage to the antenna, make sure it is retracted before running your vehicle through an automatic car wash.

CASSETTE TAPE PLAYER

Use only cassette tapes of good quality, having no damage. Avoid using tapes with a total playing time longer than 90 minutes.

Using damaged tapes will cause trouble with the tape player. Longer tapes are not recommended because of the thinness.

Be sure that the tape is not slack and that the label is firmly stuck on the shell before insertion.

Have the tape firmly wound around the tape by turning the hub with a pencil or the like.

Be careful not to touch the exposed tape surface.

When not in use, take the cassette out of the player, put it back into its case and store it away from dust, magnets and direct sunlight.

Leaving the cassettes on the dashboard in the sun could result in damaged tapes.

Keep the playback head, capstan and pinch roller clean.

Remove tape coating residue accumulated on the head, capstan and pinch roller once or twice a month. A cleaning tape is available on the market.

NOTICE:

Do not oil any part of the tape player and do not insert metal goods or a magnet into the slot, or the tape player may be damaged.

OPERATION OF INSTRUMENTS AND CONTROLS



Select Your Radio/Cassette Player

August 1992

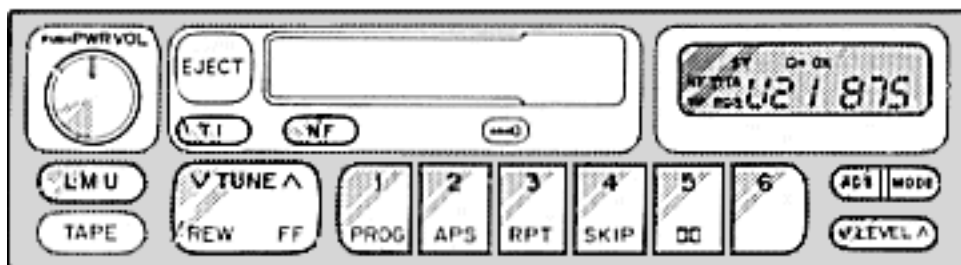
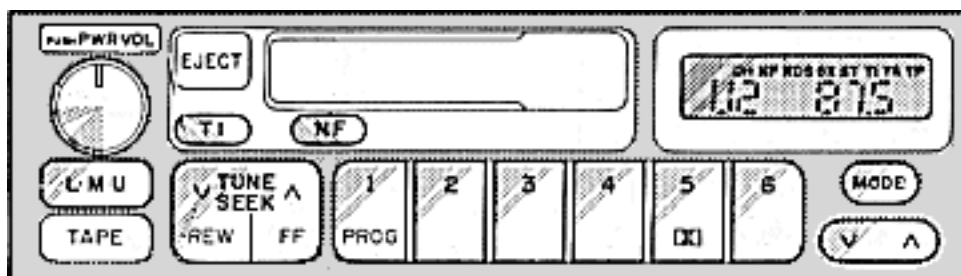



OPERATION OF INSTRUMENTS AND CONTROLS

Automatic Air Conditioner Controls

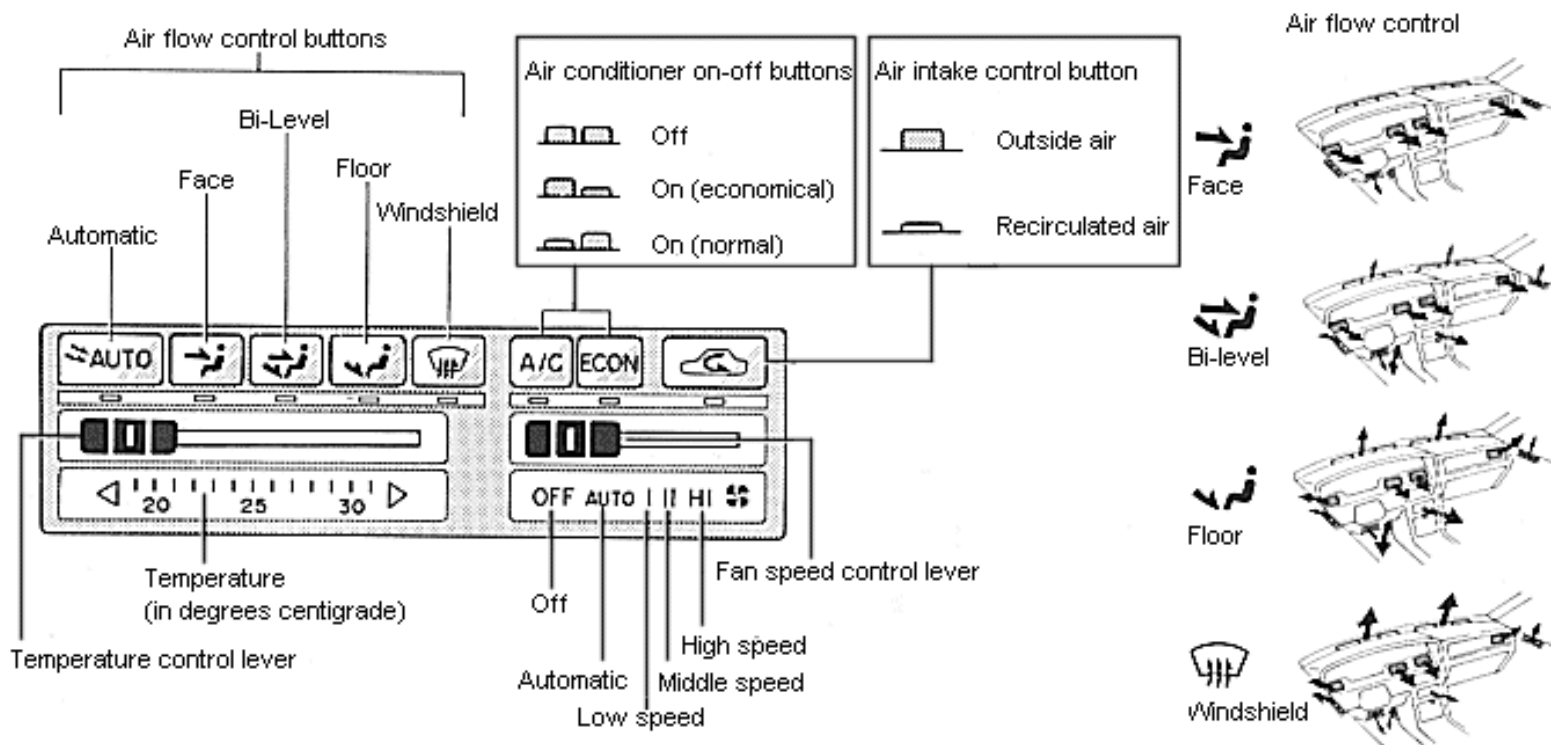

The automatic air conditioner is an air conditioner that automatically maintains the set temperature.

This air conditioner features automatic fan speed and air flow control which automatically selects the most suitable fan speed and air flow to control the temperature.

You may use manual controls if you desire your own way of setting.

(A) CLIMATE CONTROL

Setting Operation

- Place the temperature control lever at the desired temperature level.
The temperature control lever is used to set the desired passenger compartment temperature. The temperature of air delivered to the passenger compartment will be controlled automatically according to the setting. The figures on the panel indicate degrees centigrade.
- Leave the air intake control button out in the "OUTSIDE AIRE" position.
The air intake control button is used to select intake air, either outside air or recirculated air. With the button in the "OUTSIDE AIR" position, the system will take fresh outside air into the unit.
If quick circulation of conditioned air is desired, press the air intake control button to select the "RECIRCULATED AIR" position for recirculated air.
For normal use, it is best to keep the air intake control button for outside air. If recirculated air is used during heating, the windows will fog up more easily.
- Press in the "AUTO" button of the air flow control buttons.
The air flow control buttons are used to select the air flow outlets air is delivered from. If the "AUTO" button is used, the air flow outlets will be selected automatically according to the temperature of the delivered air.
If manual air flow is desired see [Manual control on air flow and fan speed](#).
- Move the fan speed control lever to the "AUTO" position.

The fan speed control lever is used to turn on and off the fan and select the fan speed. The "AUTO" position controls the fan speed automatically according to the temperature setting. If the "AUTO" position is used in cold weather, the fan will not operate until engine coolant warms up sufficiently.

If manual fan speed control is desired, see [Manual control on air flow and fan speed](#).

5. Press in either of the air condition on-off buttons.

The air conditioner on-off buttons are used to turn on and off the air conditioner.

With the "A/C" button pressed in, the air conditioner turns on and operates at its maximum capability for normal operation. Pressing in the "ECON" button operates the air conditioner at saved capability for economical operation.

If the system is used for ventilation or heating in dry weather, press the air conditioner on-off button once again. This turns off the air conditioner and improves fuel economy. For year-round automatic temperature control including cooling and dehumidifying operation, use the air conditioner.

Manual control on air flow and fan speed

If manual air flow selection is desired ...

The air flow outlets from which air is delivered can be selected manually by pressing in the appropriate air flow control button. The function of each button is as follows:

FACE button

This button directs the air flow to face level.

BI-LEVEL button

This button directs the air flow to face level and the floor. Except in ventilation, the air to the floor is slightly warmer than that to face level.

FLOOR button

This button directs the air flow mostly to the floor and face level. During heating, heated air is delivered to the floor, and unheated air is delivered to the face level.

WINDSHIELD button

This button directs the air flow mostly to the windshield, front side windows and face level. During heating, heated air is delivered to the windshield and front side windows, and unheated air is delivered to face level. As the button is pressed in, the air intake control button will come out to the "OUTSIDE AIR" position.

Do not use the WINDSHIELD button during cooling operation in extremely humid weather. The difference between the temperature of the outside air and that of the windshield could cause the outer surface of the windshield to fog up blocking your vision.

If manual fan speed control is desired ...

The fan speed can be fixed at your desired speed by moving the fan speed control lever to the appropriate position. The higher the fan speed is, the more air is delivered. Moving the lever to the "OFF" position turns off the fan.

(B) WINDSHIELD DEFOGGING AND DEFROSTING

See [CLIMATE CONTROL](#) for details on each button or lever function.

To remove interior fog on the windshield

1. Place the temperature control lever at the desired temperature level.
2. Press in the WINDSHIELD button of the air flow control buttons.
3. Move the fan speed control lever anywhere except the "OFF" position.
4. Press in either of the air conditioner on-off buttons.

To remove frost or exterior fog on the windshield

1. Place the temperature control lever at the maximum temperature.
 2. Press in the WINDSHIELD button of the air flow control buttons.
 3. Move the fan speed control lever to the "HI" position.
 4. Leave the air conditioner on-off buttons in the "OFF" position.
-

(C) OPERATING TIPS

- Be sure the air inlet grilles in front of the windshield are not blocked by leaves or other obstructions.
 - If air flow control is not satisfactory, check the dashboard vents. See [Dashboard vents](#)
 - To help cool down the interior after parking in the hot sun, drive for the first few minutes with the windows open. After the excess heat has blown away, close the windows.
 - When driving on dusty roads, close all windows. If dust thrown up by the vehicle is still drawn into the vehicle after closing the windows, it is recommended that the air intake control button be set to the "OUTSIDE AIR" position and the fan speed control lever anywhere except the "OFF" position.
 - If following another vehicle on a dusty road, or driving in windy and dusty conditions, it is recommended that the air intake control button be temporarily pressed in, which will close off the outside passage and prevent outside air and dust from entering the vehicle interior.
-

OPERATION OF INSTRUMENTS AND CONTROLS

Heater controls

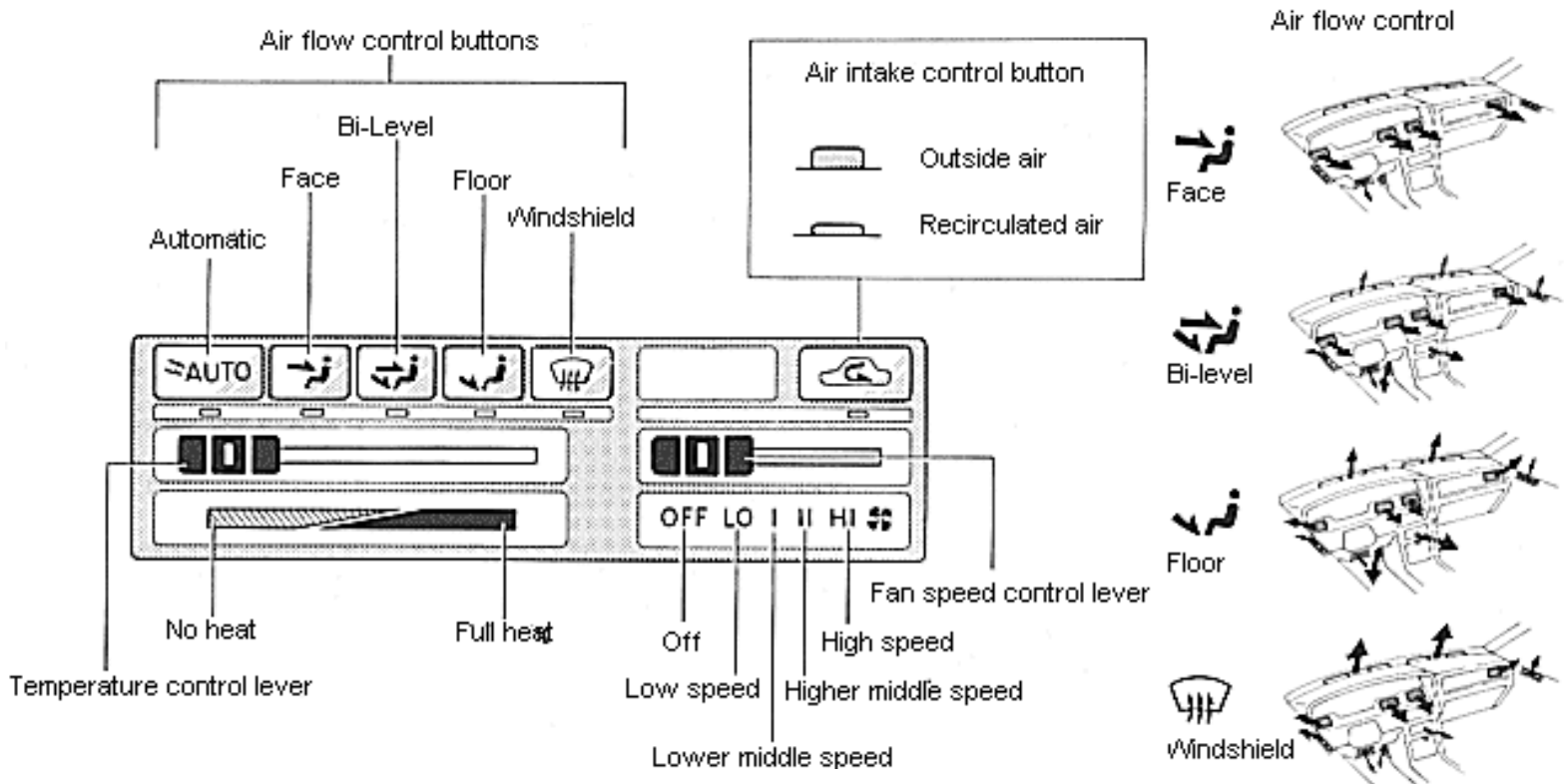

This heater features automatic air flow control which automatically selects the most suitable air flow to control the temperature.

You may use manual controls if you desire your own way of setting.

(a) Controls and functions

The temperature control lever is used to turn on and off the heater and adjust the temperature of the heated air. Move the lever toward the FULL HEATING position for high temperature. Moving the lever to the NO HEAT position turns off the heater.

The air intake control button is used to select intake air, either outside air or recirculated air

With the button in the OUTSIDE AIR position, the system will take fresh outside air into the unit. For recirculated air, press in the button to the RECIRCULATED AIR position. Pressing the button once again will let the button out in the OUTSIDE AIR position.

The air flow control buttons are used to select the air flow outlets air is delivered from.

See [Air flow selection](#) for detailed information.

The fan speed control lever is used to turn on and off the fan and select the fan speed.

The higher the fan speed setting is, the more air is delivered. Moving the lever to the "OFF" position turns the fan.

(b) Heating

1. Place the temperature control lever anywhere except the NO HEAT position.
If heated air is desired at face level, place the lever around the middle.
 2. Leave the air intake control button in the OUTSIDE AIR position.
If quick circulation of heated air is desired, press in the button.
For normal use, it is best to leave the button out. Otherwise the windows will fog up more easily.
 3. Press in the "AUTO" button of the air flow control buttons.
If heated air is desired at face level, press in the BI-LEVEL button.
For detailed information on air flow control including other settings, see [Air flow selection](#).
 4. Move the fan speed control lever anywhere except the "OFF" position.
-

(c) Ventilation

1. Place the temperature control lever at the NO HEAT position.
 2. Leave the air intake control button in the OUTSIDE AIR position.
 3. Press in the "AUTO" button of the air flow control buttons.
For detailed information on air flow control including other settings see [Air flow selection](#).
 4. Move the fan speed control lever anywhere except the "OFF" position.
-

(d) Windshield defogging and defrosting

1. Place the temperature control lever at the FULL HEATING position.
 2. Press in the WINDSHIELD button of the air flow control buttons.
For detailed information on air flow control see [Air flow selection](#).
 3. Move the fan speed control lever to the "HI" position.
-

(e) Air flow selection

AUTO button

This selects the air flow outlets automatically according to the temperature setting.

FACE button

This button directs the air flow to face level.

BI-LEVEL button

This button directs the air flow to face level and the floor. Except in ventilation, the air to the floor is slightly warmer than that to face level.

FLOOR button

This button directs the air flow mostly to the floor and face level. During heating, heated air is delivered to the floor, and unheated air is delivered to the face level.

WINDSHIELD button

This button directs the air flow mostly to the windshield, front side windows and face level. During heating, heated air is delivered to the windshield and front side windows, and unheated air is delivered to face level. As the button is pressed in, the air intake control button will come out to the "OUTSIDE AIR" position.

(f) Operating tips

- Be sure the air inlet grilles in front of the windshield are not blocked by leaves or other obstructions.
 - If air flow control is not satisfactory, check the dashboard vents. See [Dashboard vents](#)
 - To help cool down the interior after parking in the hot sun, drive for the first few minutes with the windows open. After the excess heat has blown away, close the windows.
 - When driving on dusty roads, close all windows. If dust thrown up by the vehicle is still drawn into the vehicle after closing the windows, it is recommended that the air intake control button be set to the "OUTSIDE AIR" position and the fan speed control lever anywhere except the "OFF" position.
 - If following another vehicle on a dusty road, or driving in windy and dusty conditions, it is recommended that the air intake control button be temporarily pressed in, which will close off the outside passage and prevent outside air and dust from entering the vehicle interior.
-

OPERATION OF INSTRUMENTS AND CONTROLS



Dashboard vents

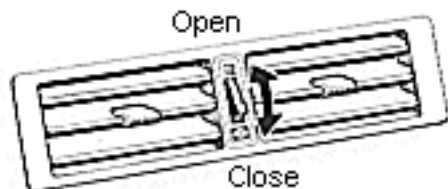

The dashboard vents may be opened or closed as shown.

OPERATION OF INSTRUMENTS AND CONTROLS



Other equipments

- [Clock](#)
- [Cigarette lighter and ashtray](#)
- [Glovebox](#)
- [Cup holder](#)
- [Luggage cover](#)

OPERATION OF INSTRUMENTS AND CONTROLS



Other equipment

Clock

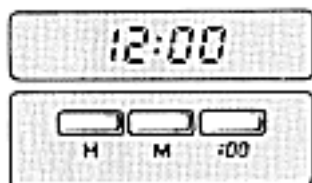

The digital clock indicates the time with the ignition key at the "ACC" or "ON" position. To reset the hour, depress the "H" button. To reset the minutes, depress the "M" button. To adjust the time to a full hour, depress the ":00" button.

For example, if the ":00" button is depressed when the time is between 1:01 - 1:29, the time will change to 1:00. If the time is between 1:30 - 1:59 the time will change to 2:00.

When the instrument panel lights are turned on, the brightness of the time indication will be reduced.

Once the electrical power source has been disconnected from the clock, the time is automatically set to 1:00 (one o'clock).

Cigarette Lighter and Ashtray

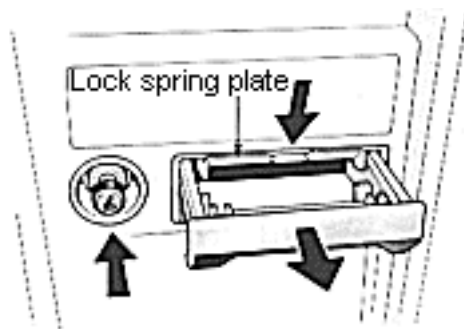

To operate the cigarette lighter, press it in. When it becomes heated, it automatically pops out ready for use.

If the engine is not running, the key must be in the "ACC" position.

Do not hold the cigarette lighter pressed in.

When finished with your cigarette, thoroughly extinguish it in the ashtray to prevent other cigarette butts from catching fire. After using the ashtray, push it back in completely.

To remove the ashtray, press down on the lock spring plate and pull out. Use a Toyota genuine cigarette lighter or equivalent for replacement.

Glovebox

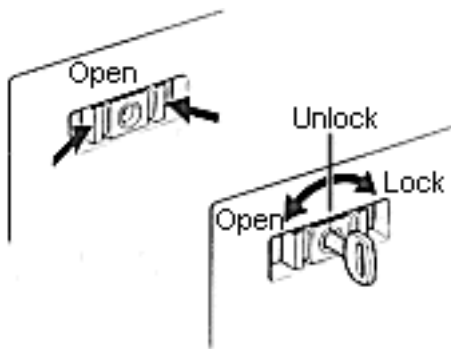

To open the glovebox door, compress the lock release buttons. To lock the glovebox door, insert the master key and turn it clockwise. With the instrument panel lights on, the glovebox light will come on when the door is open.

CAUTION:

To reduce the chance of injury in case of an accident or a sudden stop, always keep the glovebox door closed while driving.

Cup Holder

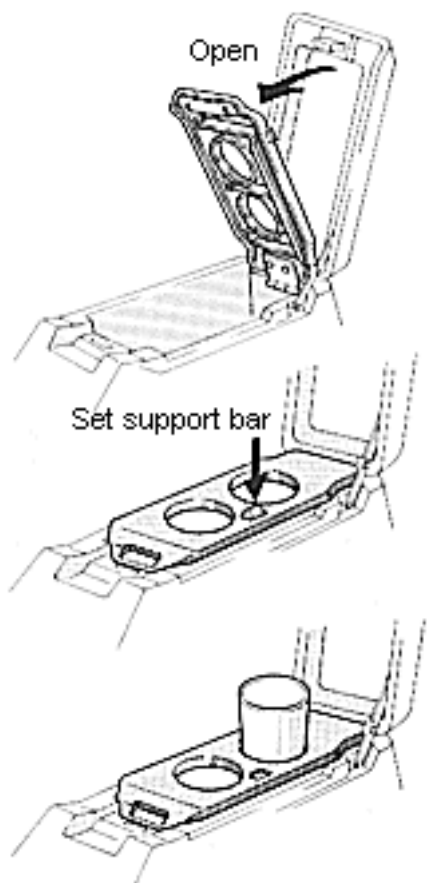

To use the cup holder, open the console box lid, swing down the cup holder and push the button to set the support bar.

The cup holder is designed for holding cup or drink-cans fit snugly in its holes.

CAUTION:

- **Do not place anything else on the cup holder, as such items may be thrown about and possible injure people in the vehicle during sudden braking or an accident.**
- **Keep the console box lid shut when the cup holder is not in use.**

Luggage Cover

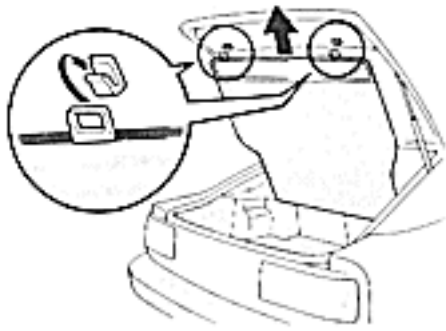

To use the luggage cover, pull it out of the retractor and hook it to the inside of the back door.

INFORMATION BEFORE DRIVING YOUR TOYOTA



- [Break-in Period](#)
- [Fuel](#)
- [Operation in Foreign Countries](#)
- [Catalytic Converter](#)
- [Engine Exhaust Cautions](#)
- [Facts about Engine Oil Consumption](#)
- [Platinum-tipped Spark Plugs](#)
- [Brake System](#)
- [Brake Pad Wear Indicators](#)
- [Luggage Stowage Precautions](#)
- [Your Toyota's Identification](#)

INFORMATION BEFORE DRIVING YOUR TOYOTA

Break-in Period



Drive gently and avoid high rpm.

For future economy and long life of your vehicle, we recommend that you follow the simple tips given below for the first 2000km (1200 miles):

- Do not run the engine over 4000 rpm. Maintain engine speed between 2000 and 4000 rpm.
 - Avoid full-throttle starts
 - Try to avoid hard stops during the first 300 km (200 miles).
 - Do not drive slowly with the transmission in a high gear.
 - Do not drive for a long time at any single speed, either fast or slow.
 - Do not tow a trailer during the first 800 km (500 miles).
-

INFORMATION BEFORE DRIVING YOUR TOYOTA



Fuel

Selecting the proper fuel is essential to satisfactory performance of the engine.

Engine damage caused by use of improper fuels is not covered under Toyota's new vehicle warranty.

FUEL TYPE

Use only unleaded gasoline

To help prevent gas station mixups, your vehicle has a new smaller fuel tank opening. The special nozzle on pumps with unleaded fuel will fit it, but the larger standard nozzle on pumps with leaded gas will not.

NOTICE:

Do not use leaded gasoline. Use of leaded gasoline will cause the catalytic converter to lose its effectiveness and the emission control system to function improperly. Also, this can increase maintenance costs.

OCTANE NUMBER

7M-GTE engine:

For optimum engine performance. Toyota recommends using premium type gasoline with an octane number of 95 or higher (Research Octane Number).

However, if such premium type cannot be obtained, you may use gasoline with an octane number as low as 91.

7M-GE engine:

Select the octane number of 97 or higher (Research Octane Number).

Use of fuel with an octane number lower than stated will cause persistent heavy knocking. If severe, this will lead to engine damage.

If your engine knocks...

If you detect heavy knocking even when using the recommended fuel, or if you hear steady knocking while holding a steady speed on level roads, consult your Toyota dealer.

However, now and then, you may notice light knocking for a short time while accelerating or driving up hills. This is no cause for concern.

FUEL TANK CAPACITY

70 Litres (18.5 US Gallons, 15.4 Imperial Gallons)

Operation in Foreign Countries

If you plan to drive your Toyota in another country...

First

comply with the vehicle registration laws.

Second

confirm the availability of the correct fuel.

INFORMATION BEFORE DRIVING YOUR TOYOTA Exhaust System



Catalytic Converter

7M-GE engine

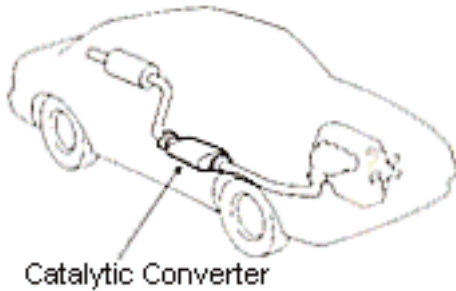

7M-GTE engine

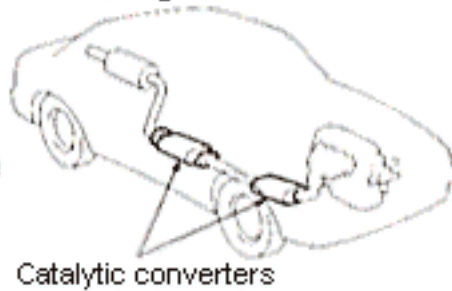

The catalytic converter is an emission control device installed in the exhaust system.

It looks somewhat like a muffler, but its purpose is to reduce pollutants in the exhaust gas.

CAUTION:

- Keep people and combustible materials away from the exhaust pipe while the engine is running. The exhaust gas is very hot.
- Do not drive, idle or park your vehicle over anything that might burn easily such as grass, leaves, paper or rags.

NOTICE:

A large amount of unburned gas flowing into the converter may cause it to overheat and create a fire hazard. To prevent this and other damage, observe the following precautions:

- Use only unleaded gasoline.
- Do not drive with an extremely low fuel level; running out of gas could cause the engine to misfire, creating an excessive load on the converter.
- Do not allow the engine to run at idle speed for more than 20 minutes.
- Avoid racing the engine.
- Do not push-start or pull-start your vehicle
- Do not turn off the ignition while the vehicle is moving.
- Keep your engine in good running order. Malfunctions in the engine electrical, ignition or fuel systems could cause an extremely high converter temperature.
- If the engine becomes difficult to start or stalls frequently, take your vehicle in for a check-up as

sson as possible. Remember, your Toyota dealer knows your vehicle and its catalytic converter system best.

- To insure that the converter and the entire emission control system operate properly, your vehicle must receive the periodic inspections required by the Toyota Maintenance Schedule.

Engine Exhaust Cautions

CAUTION:

- **Avoid inhaling the exhaust. It contains carbon monoxide, which is a colorless and odorless gas. It can cause unconsciousness or even death.**
- **Make sure the exhaust system has no holes or loose connections. The system should be checked from time to time. If you hit something, or notice a change in the sound of the exhaust, have the system checked immediately.**
- **Do not run the engine in a garage or enclosed area except for the time needed to drive the vehicle in or out. The exhaust gasses cannot escape, making this a particularly dangerous situation.**
- **Do not remain for a long time in a parked vehicle with the engine running. If it unavoidable, however, do so only in an unconfined area and adjust the heating or cooling system to force outside air into the vehicle.**
- **Keep the trunk lid, back door or tailgate closed while driving. An open or unsealed trunk lid, back door or tailgate may cause exhaust gases to be drawn into the vehicle. If you must drive with the trunk lid, back door or tailgate open to accommodate a large object, close the windows, open all the dashboard vents and have the heating or cooling system deliver fresh air into the vehicle by turning the fan to high speed with the air intake control button set in the OUTSIDE AIR mode.**
- **To allow proper operation of your vehicle's ventilation system, keep the inlet grilles in front of the windshield clear of snow, leaves or other obstructions.**
- **If you smell exhaust fumes in the vehicle, drive with the windows open and the trunk lid, back door or tailgate closed. Have the cause immediately located and corrected.**

INFORMATION BEFORE DRIVING YOUR TOYOTA



Facts about engine oil consumption

FUNCTIONS OF ENGINE OIL

Engine oil has the primary functions of lubricating and cooling the inside of the engine, and plays a major role in maintaining the engine in proper working order.

ENGINE OIL CONSUMPTION It is normal that an engine should consume some engine oil during normal engine operation. The causes of oil consumption in a normal engine are as follows.

- Oil is used to lubricate pistons, piston rings and cylinders. A thin film of oil is left on the cylinder wall when a piston moves downwards in the cylinder. High negative pressure generated when the vehicle is decelerating sucks some of this oil into the combustion chamber. This oil as well as some part of the oil film left on the cylinder wall is burned by the high temperature combustion gasses during the combustion process.
- Oil is also used to lubricate the stems of the intake valves. Some of this oil is sucked into the combustion chamber together with the intake air and is burned along with the fuel. High temperature exhaust gases also burn the oil used to lubricate the exhaust valve stems.

The amount of engine oil consumed depends on the viscosity of the oil, the quality of the oil and the conditions the vehicle is driven under.

More oil is consumed under such driven conditions as high speeds and frequent acceleration and deceleration.

A new engine consumes more oil, since its pistons, piston rings and cylinder walls have not become conditioned.

When judging the amount of oil consumption, note the oil may become diluted and make it difficult to judge the true level accurately.

As an example, if a vehicle is used for repeated short trips, and consumes a normal amount of oil, the dipstick may not show any drop in the oil level at all, even after 1000 km (600 miles) or more. This is because the oil is gradually becoming diluted with fuel or moisture, making it appear that the oil level has not changed.

The diluting ingredients evaporate out when the vehicle is then driven at high speeds, as on an expressway, making it appear that oil is excessively consumed after driving at high speeds.

IMPORTANCE OF ENGINE OIL LEVEL CHECK

One of the most important points in proper vehicle maintenance is to keep the engine oil at the optimum level so that oil function will not be impaired. Therefore, it is essential that the oil level be checked regularly. Toyota recommends that the oil level be checked every time you refuel the vehicle.

NOTICE:

Failure to check the oil level regularly could lead to serious engine troubles due to insufficient oil.

For detailed information on oil level check, see [Checking the Engine Oil Level](#).

INFORMATION BEFORE DRIVING YOUR TOYOTA



Platinum-tipped spark plugs

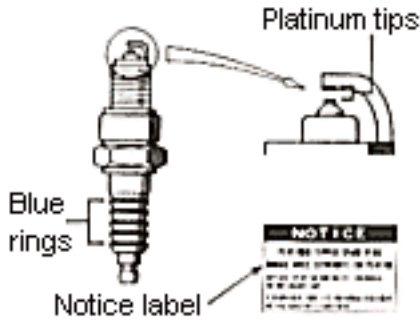

Your engine uses platinum-tipped spark plugs which do not require replacement as frequently as the conventional type. The spark plus should be replaces at regular intervals (Follow your maintenance schedule.)

When the spark plugs need to be replaces, have them replaced by a qualified technician.

The platinum-tipped spark plugs are identified by blue rings on the ceramic. They will last much longer than the conventional type.

INFORMATION BEFORE DRIVING YOUR TOYOTA

Brake System



Tandem master cylinder brake system

The tandem master cylinder brake system is a hydraulic system with two separate subsystems. If either subsystem should fail, the other will still work. However, the pedal will be harder to press, and your stopping distance will be longer. Also the brake system warning light may come on.

CAUTION:

Do not rely on a single brake system. Have your brakes fixed immediately.

Brake booster

The brake booster uses engine vacuum to power-assist the brakes. If the engine should quit while you are driving, you can bring the vehicle to a stop with normal pedal pressure. There is enough reserve vacuum for one or two stops - but no more!

CAUTION:

- **Do not pump the brake pedal if the engine stalls. Each push on the pedal uses up your vacuum reserve.**
- **Even if the power assist is completely lost, the brakes will still work. But you will have to push the pedal hard - much harder than normal. And your braking distance will be longer.**

Anti-lock brake system (vehicles with anti-lock brake system warning light)

The anti-lock brake system is designed to prevent lock-up of the wheels during sudden braking or braking on slippery surfaces to help the vehicle remain steerable and stable in such situations.

The system functions with normal pedal operation. When the anti-lock function is in action, a pulsation of the brake pedal may result, together with a characteristic noise. This indicates that the system is functioning properly.

When driving with the anti-lock brake system, keep the following in mind and adjust your driving according to the road and traffic conditions:

- Even with the anti-lock brake system, your vehicle still requires a sufficient stopping distance. Always maintain a safe distance from the vehicle in front of you.
- Always slow down when cornering. The anti-lock brake system cannot prevent accidents resulting from excessive speeds.
- On rough, gravel or snow covered roads, etc., operation of the anti-lock brake system may result in a longer stopping distance than for vehicles not fitted with an anti-lock brake system, so take this into account and reduce your speed.
- Avoid high speeds on wet roads. The anti-lock brake system cannot eliminate the risk of aquaplaning.

If the anti-lock brake system should fail, the brake system operates conventionally but without anti-lock function. Have your vehicle checked by your Toyota dealer as soon as possible.

Brake Pad Wear Indicators

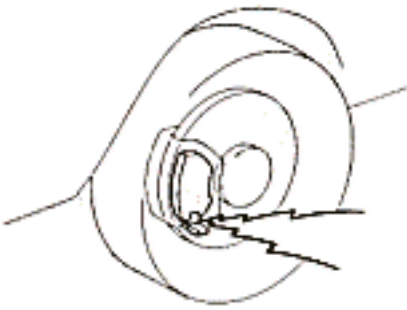

The brake pad wear indicators on your disc brakes give a warning noise when the brake pads are worn to where replacement is required.

If you hear a squealing or scraping noise while driving, have the brake pads checked and replaced by your nearest Toyota dealer immediately.

Avoid continuous driving with the warning noise.

Continuous driving without replacing the brake pads will cause expensive rotor damage and increasing brake pedal effort to get the same stopping distance.

INFORMATION BEFORE DRIVING YOUR TOYOTA



Luggage stowage precautions

When stowing luggage or cargo in or on the vehicle, observe the following:

- Put luggage or cargo in the luggage compartment when at all possible. Be sure all items are secured in place.
- Be careful to keep the vehicle balanced. Locating the weight as far forward as possible helps maintain this.
- For better fuel economy, do not carry unneeded weight.

CAUTION:

- **To prevent luggage or packages from sliding forward during braking, do not stack anything in the luggage compartment higher than the seatbacks.**
- **Never allow anyone to ride in the luggage compartment. It is not designed for passengers. They could be injured in sudden braking.**
- **Do not place anything on the luggage cover. Such items may be thrown about and possible injure peopler in the vehicle during sudden braking or an accident.**

NOTICE:

If using a roof luggage carrier on sports roofs, avoid prolonged driving on rough roads with heavy items on the roof luggage carrier.

INFORMATION BEFORE DRIVING YOUR TOYOTA



Your Toyota's Identity

Vehicle Identification Number
Manufacturer's
plate

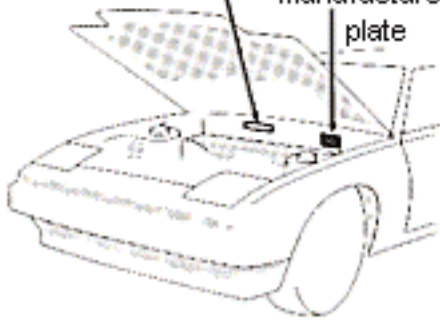

The vehicle identification number (VIN) is the legal identifier for your vehicle.

The vehicle identification number (VIN) is also on the manufacturer's plate.

This is the primary identification number for your Toyota. It is used in registering the ownership of your vehicle.

The engine number is stamped on the engine block as shown.

STARTING AND DRIVING



- [Before Starting the Engine](#)
- [How to Start the Engine \(German Owners\)](#)
- [Precautions for Turning Off a Turbo Engine](#)
- [Pretrip Safety Check](#)
- [Tips for Driving in Various Conditions](#)
- [Winter Driving Tips](#)
- [Trailer Towing](#)
- [How to Save Fuel and Make Your Vehicle last Longer](#)

STARTING AND DRIVING

Starting and Stopping the engine



Before starting the engine.

1. Check the area around the vehicle before entering it.
2. Adjust [seat position](#), [seatback angle](#), and [headrest height](#) and [steering wheel angle](#).
3. Adjust [inside](#) and [outside rear view mirrors](#).
4. Close all doors.
5. Fasten [seat belts](#).

How to start the engine

a. Before cranking

1. Apply the [parking brake](#) firmly
2. Turn off unnecessary [lights](#) and [accessories](#)
3. **Manual Transmission**

Press the clutch pedal to the floor and shift the transmissio into neutral. Hold the clutch pedal to the floor until the engine is started.

Automatic Tranmission

Put the selector lever in "P". If you need to restart the engine while the vehicle is moving, put the selector lever in "N". A starter safety device will prevent the started from operating if the selector lever is in any drive position.

4. [Automatic Transmission](#) only

Depress the brake pedal and hold it to the floor until driving off.

b. Starting the engine

Before starting the engine, be sure to follow the instructions in [Before cranking](#).

Normal starting procedure.

The electronic furl injection system in your engine automatically controls the proper air-fuel misture for starting. You can start a cold or hot engine as follows:

1. With your foot off the accelerator pedal, crank the engine by turning the key to **"START"**. Release it when the engine starts.
2. After the engine runs for about 10 seconds, you are ready to drive.

If the weather is below freezing, let the engine warm up for a few minutes before driving.

If the engine stalls...

Simply restart it, using the correct procedure given in [norml starting](#).

If the engine will not start ...

See [If the engine will not start](#).

NOTICE:

- **Do not crank for more than 15 seconds at a time. This may overheat the starter and wiring systems.**
- **Do not race a cold engine.**
- **If the engine becomes difficult to start or stalls frequently, have the engine checked immediately.**

Precautions for turning off a turbo engine (7M-GTE engine).

After high-speed or extended driving etc., requiring a heavy engine load, the engine should be allowed to idle as shown in the chart, before turning it off.

Driving condition and required idling time.

Normal city driving.

Idling time -- Not necessary

High-speed driving.

About 80 km/h (50 mph)

Idling time -- About 20 seconds

About 100 km/h (63 mph)

Idling time -- About 1 minute

Above 100 km/h (63 mph)

Idling time -- About 2 minutes

Steep mountain slopes driving.

Idling time -- About 2 minutes

NOTICE:

Never turn the engine off immediately after a heavy load. This may cause severe engine damage.

STARTING AND DRIVING



Pretrip safety check

It is a good idea to review the safety check before starting out on a trip. A few minutes of checking can help ensure safe and pleasant driving. Just a basic familiarity with your vehicle is required and a careful eye! Or if you would like, your Toyota dealer will be please to make this check for you at nominal cost.

CAUTION:

If you make this check in an enclosed garage, make sure there is adequate ventilation. engine exhaust is poisonous.

BEFORE STARTING THE ENGINE

Outside the vehicle.

Tires

Check the pressure with a gauge and look carefully for cut, damage, or excessive wear.

Wheel nuts

Make sure no nuts are missing or loose.

Fluid leaks

After the vehicle has been parked for a while, check underneath for leaking fuel, oil, water or fluid. (Water dripping from the air conditioner after use is normal.)

Wiper blades

Look for wear or cracks.

Lights

Make sure that the headlights, stop lights, tail lights, turn signals and other lights are all working. Check the headlight aim.

Inside the vehicle.

Spare tire, jack and wheel nut wrench

Check the tire pressure and make sure you have your jack and wheel nut wrench.

Seat belts

Check that the buckles lock securely. Make sure that the belts are not worn or frayed.

Horn

Does it work?

Instruments and controls

Especially make sure that the warning lights, instrument lights, and defroster are working.

Wipers and washer

Make sure that they both work and that the wipers do not streak.

Brakes

Make sure that the pedal has enough clearance. (See [Checking the Brake Pedal Clearance.](#))

Spare fuses

Make sure you have spare fuses. They should cover all the amperage ratings designated on the fuse box lid.

In the engine compartment.

Coolant level

Make sure that the coolant level is correct. (See [Checking the Engine Coolant Level.](#))

Radiator and hoses

Make sure that the front of the radiator is clean - not blocked with leaves, dirt or bugs. Check the hoses for cracks, kinks, rot and loose connections.

Battery and cables

All the battery cells should be filled to the proper level with distilled water. Look for corroded or loose terminals and a cracked case. Check the cables for good condition and connections.

Wiring

Look for damaged, loose or disconnected wires.

Brakes and clutch fluid levels

Make sure that the brake and clutch fluid levels are correct. (See [Checking the Brake and Clutch Fluid.](#))

Engine drive belts.

Check all belts for fraying, cracks, wear or oiliness. apply thumb pressure between the pulleys. The deflection of each belt should be within the specified limits. (See [Checking the Engine Drive Belts.](#))

Fuel lines

Check the lines for leaks or loose connections.

AFTER STARTING THE ENGINE

Exhaust system

Look for cracks, holes and loose supports. If you notice any change in the sound of the exhaust or smell exhaust fumes, have the cause located and corrected immediately. (See [Carbon Monoxide Warning](#))

Automatic transmission fluid

Check the dipstick with the engine idling and the selector lever in "P". (See [Checking Automatic Transmission Oil.](#))

Power steering fluid

With the engine idling, give the steering wheel several end-to-end turns and check the fluid level. (See [Checking the Power Steering Fluid.](#))

Engine oil level

Stop the engine and check the dipstick with the vehicle parked on a level spot. (See [Checking the Engine Oil Level.](#))

WHILE DRIVING

Instruments

Make sure that the speedometer and gauges are working.

Brakes

At a safe place make sure the brakes do not pull.

Anything unusual?

Look for loose parts and leaks. Listen for abnormal noises.

If everything looks O.K., set your mind at ease and enjoy your trip.

STARTING AND DRIVING



Tips for Driving in Various Conditions

- Always slow down in gusty crosswinds. This will allow you much better control.
- Drive slowly onto curbs and, if possible, at a right angle. Avoid driving onto high, sharp-edged objects and other road hazards. Failure to do so can lead to severe tire damage resulting in tire bursts.
- When parking on a hill, turn the front wheels until they touch the curb so that the vehicle will not roll. Apply the parking brake, and place the transmission in "P" (automatic) or in first or reverse (manual). If necessary, block the wheels.
- Washing your vehicle or driving through deep water may get the brakes wet. To see whether they are wet, check that there is no traffic near you, and then press the pedal lightly. If you do not feel a normal braking force, the brakes are probably wet. To dry them, drive the vehicle cautiously while lightly pressing the brake pedal with the parking brake pulled. If they still do not work safely, pull to the side of the road and call a Toyota dealer for assistance.

CAUTION:

- **Before driving off, make sure that the parking brake is fully release and the parking brake reminder light is off.**
- **Do not leave your vehicle unattended while the engine is running.**
- **Do not rest your foot on the brake pedal while driving. It can cause dangerous overheating, needless wear, and poor fuel economy.**
- **To drive down a long or steep hill, reduce your speed and downshift. Remember, if you ride the brakes excessively, they may overheat and not work properly.**
- **Be careful when accelerating, upshifting, downshifting or braking on a slippery surface. Sudden acceleration or engine braking could cause the vehicle to spin or skid.**
- **Do not continue normal driving when the brakes are wet. If they are wet, your vehicle will require a longer stopping distance, and it may pull to one side when the brakes are applied. Also, the parking brake will not hold the vehicle securely.**

NOTICE:

When driving on wet roads, avoid driving through large amounts of standing water on the road. large amounts of water entering the engine compartment may cause damage to the engine and/or electrical components.

STARTING AND DRIVING



Winter Driving Tips

- **Make sure you have ethylene-glycol antifreeze in the radiator.**

NOTICE:

Do not use alcohol type antifreeze.

- **Check the condition of the battery and cables.**

Cold temperatures reduce the capacity of any battery, so it must be in top shape to provide enough power for winter starting. [Checking the Battery Condition and Fluid Levels](#). Your Toyota dealer and most service stations will be pleased to check the level of charge.

- **Make sure the engine oil viscosity is suitable for the cold weather.**

[Recommended Viscosity](#). Leaving a heavy summer oil in your vehicle during winter months may cause harder starting. If you are not sure about which oil to use, call your Toyota dealer - they will be pleased to help.

- **Keep the door locks from freezing.**

Squirt lock de-icer or glycerine into the locks to keep them from freezing. To open a frozen lock, try heating the key before inserting it.

- **Keep the retractable headlights raised when there is a possibility they could freeze.**

- **Use a washer fluid containing an antifreeze solution.**

This product is available at your Toyota dealer and most auto parts stores. Follow the manufacturer's directions for how much to mix with water.

NOTICE:

Do not use engine antifreeze or any other substitute as washer fluid because it may damage your vehicle's paint.

- **Do not use your parking brake when there is a possibility it could freeze.**

When parking, put the transmission into "P" (automatic) or into first or reverse (manual) and block the front wheels. Do not use the parking brake, or snow or water accumulated in and around the parking brake mechanism may freeze the parking brake making it hard to release.

- **Keep ice and snow from accumulating under the fenders.**

Ice and snow build up under your fenders can make steering difficult. During bad winter driving, stop and check under the fenders occasionally.

- **Depending on where you are driving, we recommend you carry some emergency equipment.**

Some of the things you might put in the vehicle are tire chains, window scraper, bag of sand or salt, flares, small shovel, jumper cables, etc.

STARTING AND DRIVING



Trailer Towing

Your vehicle is designed primarily as a passenger-carrying vehicle. Towing a trailer will have an adverse effect on handling, performance, braking, durability and driving economy (fuel consumption, etc.). Your safety and satisfaction depend on the proper use of correct equipment and cautious driving habits. For your safety and the safety of others, you must not overload your vehicle or trailer. Toyota warranties do not apply to damage or malfunction caused by towing a trailer for commercial purposes. Ask your local Toyota dealer for further details before towing, as there are additional legal requirements in some countries.

WEIGHT LIMITS

Before towing, confirm the towing capacity with your local Toyota dealer or the vehicle documents and make sure your trailer is within the towing capacity.

Towing capacity has been tested at sea-level. If you have to go to a high mountain area, keep in mind that the engine power and towing capacity will decrease.

TOWING BRACKETS

Toyota recommends using only Toyota-genuine-bracket.

TIRES

- Ensure that your vehicle's tires are properly inflated. ([Checking Tyre Pressure.](#))
- The trailer tires should be inflated to the pressure recommended by the trailer manufacturer in respect to the total trailer weight.

TRAILER LIGHTS

- Check for correct operation of the turn signals and stop lights each time you hitch up. Direct splicing may damage your vehicle's electrical system and cause a malfunction of your lights.

BREAK-IN SCHEDULE

- Toyota recommends that you do not tow a trailer with a new vehicle or a vehicle with any new power train components (engine, transmission, differential, wheel bearings, etc.) for the first 800 km (500 miles) of driving.

MAINTENANCE

- If you tow a trailer, your vehicle will require more frequent maintenance due to the additional load.

PRE-TOWING SAFETY CHECK

- Be sure not to exceed designated maximum load for the ball coupling of the towing bracket. Please remember that the ball coupling load will increase the load on the vehicle. Maximum permissible rear axle capacity must not be exceeded.
- Be sure the trailer cargo is securely loaded so that it may not shift.
- If the traffic behind the trailer cannot be seen properly with the standard rear view mirrors, additional outside mirrors will be necessary. Both outside mirrors must be fitted on folding arms and adjusted to give a good rear view at all times.

TRAILER TOWING TIPS

When towing a trailer, your vehicle will handle differently than when not towing. The three main causes of vehicle-trailer accidents are driver error, excessive speed and improper trailer loading. Keep these in mind when towing:

- Before starting out, check operation of the lights and all vehicle-trailer connections. After driving a short distance, stop and recheck the lights and connections. Before actually towing a trailer, practice turning, stopping and backing with a trailer in an area away from traffic until you learn the feel.
- Because stopping distance may be increased, vehicle-to-vehicle distance should be increased when towing a trailer. For each 10 km/h (6mph) of speed, allow at least one vehicle and trailer length between you and the vehicle ahead. Avoid sudden braking as you may skid, resulting in jackknifing and loss of control. This is especially true on wet or slippery surfaces.
- Avoid jerky starts or sudden acceleration. If your vehicle has a manual transmission, prevent excessive clutch slippage by keeping engine rpm low and not racing the engine. Always start out in first gear.
- Avoid jerky steering and sharp turns. The trailer could hit your vehicle in a tight turn. Slow down before making a turn to avoid the necessity of sudden braking.
- Backing with a trailer is difficult and requires practice. Have someone guide you when backing to reduce the risk of an accident.
- Remember that when making a turn, the trailer wheels will be closer to the vehicles wheels to the inside of the turn. Therefore, compensate for this by making a larger than normal turning radius with your vehicle.
- Crosswinds and rough roads will adversely affect handling of your vehicle and trailer, causing sway, pay attention to the rear from time to time to prepare yourself for being passed by large trucks or buses, which may cause your vehicle and trailer to sway. If swaying happens, firmly grip the steering wheel and reduce speed immediately but gradually. Never increase speed. If it is necessary to reduce speed, brake slowly. Steer straight ahead. If you make no extreme correction with the steering or brakes, the vehicle and trailer will stabilize.
- Be careful when passing other vehicles. Passing requires considerable distance. After passing a vehicle, do not forget the length of your trailer and be sure you have plenty of room before changing lanes.
- In order to maintain engine braking efficiency, do not use fifth gear (manual) or overdrive (automatic).
- Because of the added load of the trailer, your vehicle's engine may overheat on hot days (at temperatures over 30°C (85°F) when going up a long or steep grade with a trailer. If the engine temperature gauge indicates overheating, immediately turn off the air conditioner (if in use), pull off the road and stop in a safe spot. Refer to [If Your Vehicle Overheats](#).
- Always place wheel blocks under both the vehicle and trailer wheels when parking. Apply the parking brake firmly. Put the transmission in "P" (automatic) or in first or reverse (manual).

CAUTION:

- **Observe the legal maximum speeds for trailer towing.**
 - **Slow down and downshift before descending steep or long downhill grades. Do not make sudden downshifts.**
 - **Avoid holding the brake pedal down too long or too frequently. This could cause the brakes to overheat and result in reduced braking efficiency.**
-

STARTING AND DRIVING



How to Save Fuel and Make Your Vehicle last Longer

Getting more kilometers/mileage from a litre/gallon of fuel is easy - just take it easy. It will help make your vehicle last longer, too. Here are some specific tips on how to save money on both fuel and repairs:

- **Keep your tyres inflated at the correct pressure.** Underinflation causes tyre wear and wastes fuel. [Checking Tyre Pressure.](#)
- **Do not carry unneeded weight in your vehicle.** Excess weight puts a heavier load on the engine, causing greater fuel consumption.
- **Avoid length warm-up idling.** Once the engine is running smoothly, begin driving - but gently. Remember, however, that in cold winter days this may take a little longer.
- **Accelerate slowly and smoothly.** Avoid jackrabbit starts. Get into high gear as quickly as possible.
- **Avoid long engine idling.** If you have a long wait and you are not in traffic, it is better to turn off the engine and start again later.
- **Avoid engine lug or overreccing.** Use a gear range suitable for the road on which you are travelling.
- **Avoid continuous speeding up and slowing down.** Stop-and-go driving wastes fuel.
- **Avoid unnecessary stopping and braking.** Maintain a steady pace. Try to time the traffic signals so you only need to stop as little as possible or take advantage of through streets to avoid traffic lights. Keep a proper distance from other vehicles to avoid sudden braking. This will also reduce wear on your brakes.
- **Avoid heavy traffic or traffic jams whenever possible.**
- **Maintain a moderate speed on highways.** The faster you drive, the greater the fuel consumption. By reducing your speed, you will cut down on fuel consumption.
- **Keep the front wheels in proper alignment.** Avoid hitting the curb and slow down on rough roads. Improper alignment not only causes faster tyre wear but also puts an extra load on the engine, which, in turn, wastes fuel.
- **Keep the bottom of your vehicle free from mud, etc.** This not only lessens weight but also helps prevent corrosion.
- **Keep your vehicle tuned-up and in top shape.** A dirty air cleaner, improper valve clearance, dirty plugs, dirty oil and grease, brakes not adjusted, etc. all lower engine performance and contribute to poor fuel economy. For longer life of all parts and lower operating costs, keep all maintenance work on schedule, and if you often drive under severe conditions, see that your vehicle receives more frequent maintenance.

CAUTION:

Never turn off the engine to coast down hills. Your power steering and brake booster will not function without the engine running. Also, the emission control system operates properly when the engine is running.

IN CASE OF AN EMERGENCY



1. [If Your Vehicle Will Not Start](#)
2. [If Your Engine Stalls While Driving](#)
3. [If Your Vehicle Overheats](#)
4. [If You Have a Flat Tyre](#)
5. [If Your Vehicle Needs To Be Towed \(Germany Only\)](#)
6. [If a Retractable Headlight Does Not Operate](#)
7. [If You Lose Your Keys](#)

IN CASE OF AN EMERGENCY



If Your Vehicle Will Not Start

(a) Simple Checks.

Before making these checks, make sure you have followed the correct starting procedure given in [How To Start The Engine](#) and that you have sufficient fuel.

If the engine is not turning over or is turning over too slowly ...

1. Check that the battery terminals are tight and clean.
2. If the battery terminals are O.K., switch on the interior light.
3. If the light is out, dim or goes out when the start is cranked, the battery is discharged. You may try [jump starting](#). But your vehicle cannot be push started.
4. If the light is O.K., but the engine still will not start, it needs adjustment or repair. Call a Toyota dealer or qualified repair shop.

NOTICE:

Do not pull-start the vehicle. It may damage the vehicle or cause a collision when the engine starts. Do not try push-starting either. The catalytic converter may overheat and become a fire hazard.

If the engine turns over at its normal speed but it will not start ...

1. 7M-GE engine only ... Check that all the push-on connectors are tight at the ignition coil, distributor, and spark plugs. (See [Engine Compartment Overview](#) for location of these parts)
2. If the connectors are O.K. the engine may be flooded because of repeated cranking. See [Starting the flooded engine](#) for further instructions.

(b) Starting a Flooded Engine.

If the engine will not start, your engine may be flooded because of repeat cranking.

If this happens, turn the key to "START" with the accelerator pedal held down. Keep the key and accelerator pedal held for 15 seconds and then release them. Then try starting the engine with your foot off the accelerator pedal.

If the engine does not start after 15 seconds of cranking, release the key, wait a few minutes and try again. If the engine still will not start, it needs adjustment or repair. Call a Toyota dealer or qualified repair shop for assistance.

NOTICE:

Do not crank for more than 15 seconds at a time. This may overheat the starter and wiring systems.

(c) Jump Starting.

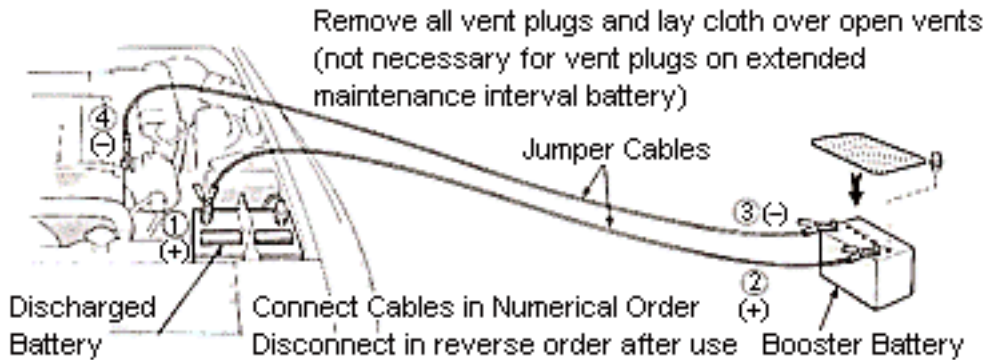

To avoid serious personal injury and damage to your vehicle which might result from battery exposure, acid burns, electrical burns, or damaged electronic components, these instructions must be followed precisely.

If you are unsure about how to follow this procedure, we strongly recommend that you seek the help

of a competent mechanic or towing service.

CAUTION:

- **Batteries contain sulfuric acid which is poisonous and corrosive. Wear protective safety glasses when jump starting, and avoid spilling acid on your skin, clothing, or vehicle.**
- **If you should accidentally get acid on yourself or in your eyes, remove any contaminated clothing and flush the affected areas with water for at least 15 minutes. Then get immediate medical attention. If possible, continue to apply water with a sponge or cloth while en route to the medical office.**
- **The gas normally produced by a battery will explode if a flame or spark is brought near. Use only standardised jumper cable and do not smoke or light a match while jump starting.**

NOTICE:

The battery used for boosting must be 12V. Do not jump start unless you are sure that the booster battery is correct.

JUMP STARTING PROCEDURE

1. If the booster battery is installed in another vehicle, make sure the vehicles are not touching. Turn off all unnecessary lights and accessories.
2. Remove all the vent plugs from the booster battery. Lay a cloth over the open vents on the booster

battery. (This helps reduce the explosion hazard.)

If the booster battery is an extended maintenance interval battery, it is not necessary to remove the vent plugs.

3. If the engine in the vehicle with the booster battery is not running, start it and let it run for a few minutes. During jumping run the engine at about 2000 rpm with the accelerator pedal lightly depressed.
4. Connect the jumper cables in the exact order shown in the illustration: positive-to-positive (+), and negative to engine or body ground (--). Note that you first connect the positive cable to the discharged battery. Next, connect the negative cable to the booster battery and then to a solid, stationary metallic point (e.g. engine hanging hook) away from the battery. Do not connect it to or near any part that moves when the engine is cranked.

NOTICE:

When making the connections, do not lean over the battery or accidentally let the jumper cables or clamps touch anything except the correct battery terminals or the ground.

5. Start your engine in the normal way. After starting, run it at about 2000 rpm for several minutes with the accelerator pedal lightly depressed.
6. Carefully disconnect the cables in the exact reverse order: the negative cable and then the positive cable.
7. Carefully dispose of the battery cover cloths - they may now contain sulfuric acid.
8. Replace all battery vent plugs

If the cause of your battery discharging is not apparent (e.g. lights left on), you should have it checked.

IN CASE OF AN EMERGENCY



If Your Engine Stalls While Driving

1. Reduce your speed gradually, keeping a straight line. Move cautiously off the road to a safe place.
2. Turn on your emergency flashers.
3. Try starting the engine again.

If the engine will not start, see [If Your Vehicle Will Not Start](#).

CAUTION:

If the engine is not running, the power assist for the brakes and steering will not work so steering and braking will be much harder than usual.

IN CASE OF AN EMERGENCY



If Your Vehicle Overheats

If your temperature gauge indicates overheating, if you experience a loss of power, or if you hear a loud knocking or pinging noise, the engine has probably overheated. You should follow this procedure ...

1. Pull safely off the road, stop the vehicle and turn on your emergency flashers. Put the transmission in "P" (automatic) or neutral (manual) and apply the parking brake. Turn off the air conditioner if it is being used.
2. If coolant or steam is boiling out of the radiator or reservoir, stop the engine. Wait until the steam subsides before opening the hood. If there is no coolant boiling over or steam, leave the engine running.

CAUTION:

To help avoid personal injury, keep the hood closed until there is no steam. Escaping steam or coolant is a sign of high pressure.

3. Visually check to see if the engine drive belt (fan belt) is broken or loose. Look for obvious coolant leaks from the radiator, hoses, and under the vehicle. However, note that water draining from the air conditioner is normal if it has been used.

CAUTION:

When the engine is running, keep hands and clothing away from the moving fan and engine drive belts.

4. If the engine drive belt is broken or the coolant is leaking, stop the engine immediately. Call a Toyota dealer for assistance.
5. If the engine drive belt is O.K. and there are no obvious leaks, you may help the engine cool down more quickly by running it at about 1500 rpm for a few minutes with the accelerator pedal lightly depressed.
6. Check the coolant reservoir. If it is dry, add water to the reservoir while the engine is running. Fill it about half full.

CAUTION:

Do not attempt to remove the radiator cap when the engine and radiator are hot. Serious injury could result from scalding hot fluid and steam blown out under pressure.

7. After the engine temperature has cooled to normal, again check the coolant level in the reservoir. If necessary, bring it up to half full again. Serious coolant loss indicates a leak in the system. you should have it checked as soon as possible at your Toyota dealer.
-

IN CASE OF AN EMERGENCY



If You Have a Flat Tyre

1. Reduce your speed gradually, keeping a straight line. Move cautiously off the road to a safe place well away from the traffic. Avoid stopping on the center divider of a highway. Park on a level spot with firm ground.
2. Stop the engine and turn on your emergency flashers.
3. Firmly set the parking brake and put the transmission in "P" (automatic) or reverse (manual).
4. Have everyone get out of the vehicle on the side away from traffic.
5. Read the following instructions thoroughly.

CAUTION:

When jacking, be sure to observe the following to reduce the possibility of personal injury:

- Follow jacking instructions.
- Use a jack only for lifting your vehicle during wheel changing.
- Never get beneath the vehicle when supported by a jack.
- Do not start or run the engine while your vehicle is supported by a jack.

NOTICE

Do not continue driving with a delated tyre. Driving even a short distance can damage a tyre beyond repair.

If your vehicle is equipped with a 205/55R16 spare tyre or 225/50ZR16 spare tyre with turning direction indicators, keep the following in mind.

For the 205/55R16 spare tyre.

The 205/55R16 spare tyre is designed for temporary emergency use only.

The original 225/50ZR16 tyre should be repaired and replaced as soon as possible.

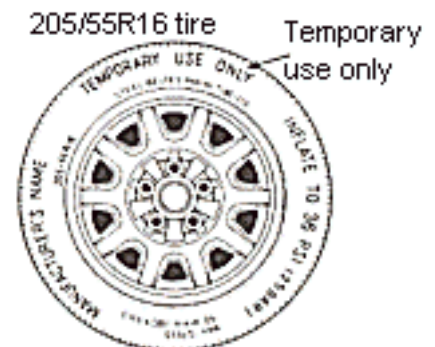

CAUTION:

- **Do not use more than one 205/55R16 spare tyre at the same time.**
- **Do not exceed 80 km/h (50 mph) when driving with the 205/55R16 spare tyre.**

For the 225/50ZR16 spare tyre with turning direction indicators.

Your spare tyre is of a uni-directional type, and is intended for use on the right side on left-hand drive vehicles and the left side on right-hand drive vehicles.

If you use the spare tyre on the opposite side to the designated side, have the flat tyre repaired and replace the flat tyre with it as soon as possible.

225/50ZR tire with turning direction indicators

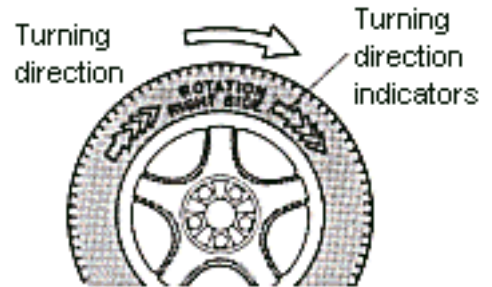

... Required tools and spare tyre

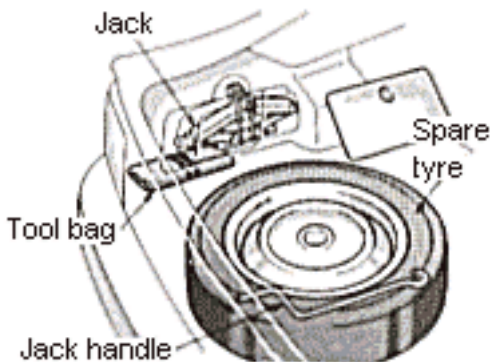

Required tools inside the tool bag

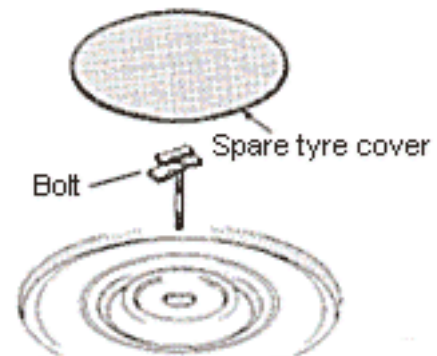
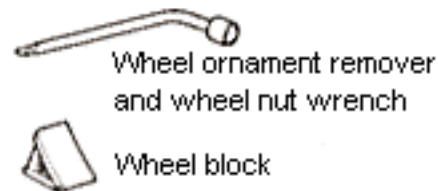

1. Get the tool bag, jack, jack handle and spare tyre.

To prepare yourself for an emergency, you should familiarize yourself with the use of the jack, each of the tools and their storage locations.

To remove the spare tyre

1. Remove the spare tyre cover.
2. Loosen the bolt and remove it.

When storing the spare tyre, put it into place with the cuter side of the wheel facing up. Then secure the tyre by repeating the above removal steps in reverse order to prevent it from flying forward during a collision or sudden braking.

... Blocking the wheel

2. **Block the wheel diagonally opposite the flat tyre to keep the vehicle from rolling when it is jacked up.**

When blocking the wheel, place the wheel block from the front for the front wheels or from the rear for the rear wheels.

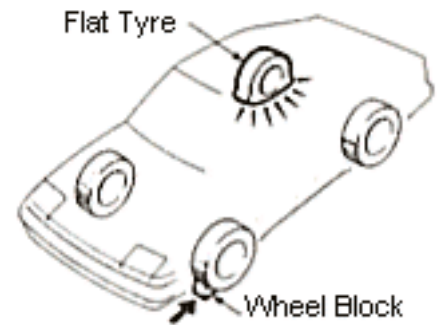

... Removing wheel ornament

3. **Remove the wheel ornament.**

Pry off the wheel ornament, using the beveled end of the wheel nut wrench as shown. To avoid personal injury, do not attempt to pull off the ornament by hand.

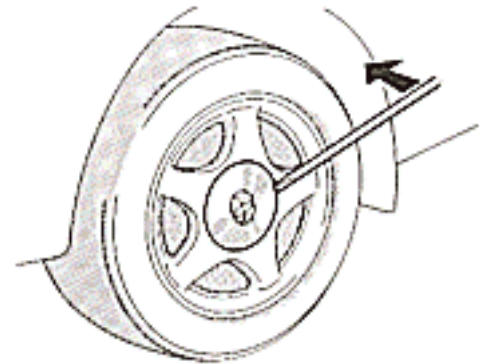

... Loosening wheel nuts

4. **Loosen all the wheel nuts.**

Always loosen the wheel nuts before raising the vehicle. The nuts turn counterclockwise to loosen. To get maximum leverage, fit the wrench to the nut so that the handle is on the right side, as shown above. Grip the wrench near the end of the handle and pull up on the handle. Be careful that the wrench does not slip off the nut. Do not remove the nuts yet -- just unscrew them about one-half turn.

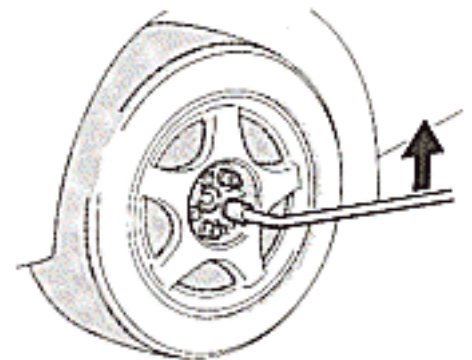

... Positioning the jack

5. **Position the jack at the correct jack point as shown.**

Make sure that the jack is positioned on a level and solid place.

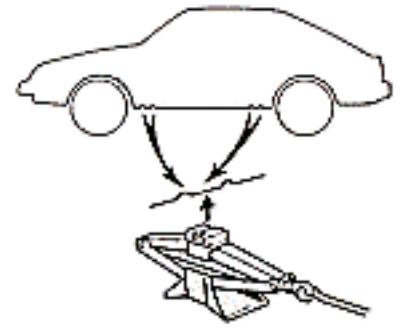

... Raising your vehicle

6. **After making sure that no one is in the vehicle, raise it high enough so that the spare tyre can be installed.**

Remember you will need more ground clearance when putting on the spare tyre than when removing the flat tyre

To raise the vehicle, insert the jack handle into the jack (it is a loose fit)

and turn it clockwise. As the jack touches the vehicle and begins to lift, double-check that it is properly positioned.

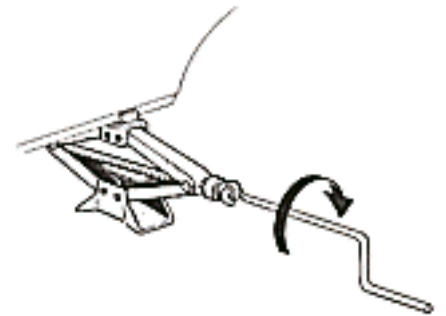

CAUTION:

Never get under the vehicle when it is supported by the jack alone.

... Changing wheels

7. **Remove the wheel nuts and change tyres.**

Lift the flat tyre straight off and put it aside.

Roll the spare wheel into position and align the holes in the wheel with the bolts. Then lift up the wheel and get at least the top bolt started through its hole. Wiggle the tyre and press it back over the other bolts.

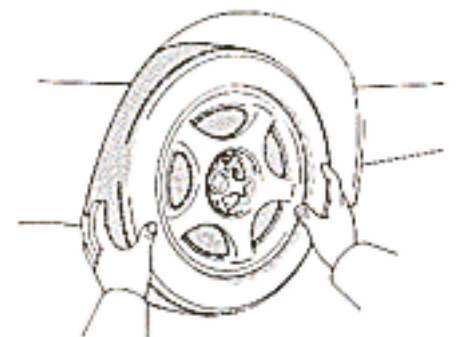

Before putting on wheels, remove any corrosion on the mounting surfaces with a wire brush or such. Installation of wheels without good metal-to-metal contact at the mounting surface can cause wheel nuts to loosen and eventually cause a wheel to come off while driving. Therefore after the first 1600km (1000 miles), check to see that the wheel nuts are tight.

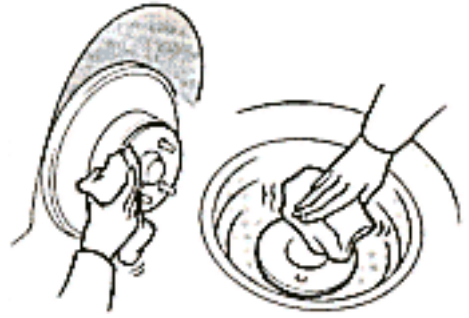

... Reinstalling the wheel nuts

8. Reinstall all wheel nuts finger tight.

Reinstall the wheel nuts and tighten them as much as you can be hand. Press back on the tyre and see if you can tighten them more

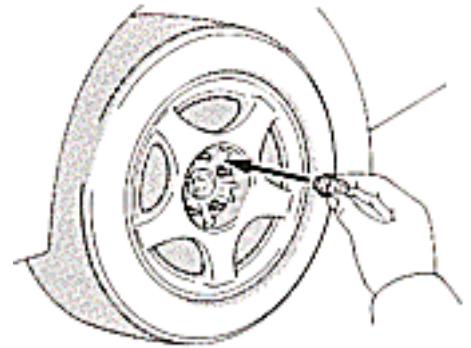

... Lowering your vehicle

9. Lower the vehicle completely and tighten the wheel nuts.

Turn the jack handle counterclockwise to lower the vehicle. Use the wheel nut wrench to tighten the nuts. Do not use other tools or any additional leverage other than your hands, such as a hammer, pipe or your foot. Make sure the wrench is securely engaged over the nut.

Tighten each nut a little at a time in the order shown. Repeat the process until all nuts are tight.

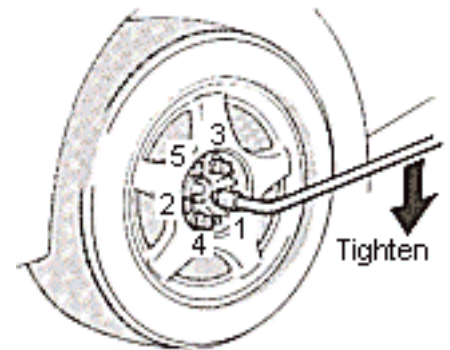

... Reinstalling wheel ornament

10. Reinstall the wheel ornament.

Turn the jack handle counterclockwise to lower the vehicle.
Put the wheel ornament into position and then tap it firmly with the side or heel of your hand to snap it into place.
The wheel ornament cannot be installed on the 205/55R16 tyre.

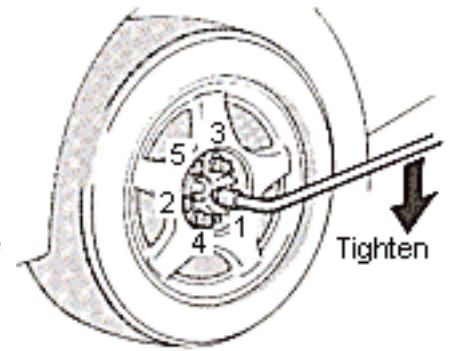

... After changing wheels

11. Check the air pressure of the replaced tyre.

Adjust the air pressure to the [pressure specified](#). If the pressure is lower, drive slowly to the nearest service station and fill to the correct pressure.
Do not forget to reinstall the tyre inflation valve cap as tyre and moisture could get into the valve core and possibly cause air leakage. If the cap is missing, have a new one put on as soon as possible.

12. Restow all the tools, jack and flat tyre securely.

As soon as possible after changing wheels, tighten the wheel nuts to the [torque specified](#) with a torque wrench, have a technician repair the flat tyre and replace the spare tyre with it.
This is the same procedure for changing or rotating your tyres.

CAUTION:

Before driving, make sure all the tools, jack and flat tyre are securely in place in their storage location to reduce the possibility of personal injury during a collision or sudden braking.

IN CASE OF AN EMERGENCY

If Your Vehicle Needs to be Towed



If towing is necessary, we recommend you have it done by your Toyota dealer or a commercial tow truck service.

Proper equipment will help ensure that your vehicle is not damaged while being towed. Commercial operators are generally aware of the state/provincial and local laws pertaining to towing.

Your vehicle can be damaged if it is towed incorrectly. Although most operators know the correct procedure, it is possible to make a mistake. To avoid damage to your vehicle, make sure the following few precautions are observed. If necessary, show this page to the tow truck driver.

TOWING PRECAUTIONS

Use a safety chain system for all towing, and abide by the state/provincial and local laws. The wheels and axle on the ground must be in good condition. If they are damaged, use a towing dolly.

(a) Using flat bed truck

Toyota recommends this as the best method for your vehicle.

(b) Towing with wheel lift type truck

From front ...

- Manual Transmission:

We recommend using a towing dolly under the rear wheels. If you do not use a towing dolly, release the parking brake and put the transmission in neutral.

- Automatic transmission:

Use a towing dolly under the rear wheels.

NOTICE:

Never tow a vehicle with an automatic transmission from the front with the rear wheels on the ground, as this may cause serious damage to the transmission.

From rear ... Place the ignition key in the "ACC" position.

NOTICE:

Do not tow with the key removed or in the "LOCK" position, as the steering lock mechanism is not strong enough to hold the front wheels straight while towing.

(a) Using flat bed truck



(b) Towing with wheel lift type truck

... from front



... from rear



(c) Towing with sling type truck



(c) Towing with sling type truck

From front ...

NOTICE:

Do not tow with sling type truck. This may cause body damage.

From rear ...Follow the instructions for towing from rear in [Towing with Wheel Lift Type Truck](#).

Emergency towing (Germany)

If towing service is not available in an emergency, your vehicle may be temporarily trailed by a cable secured to the emergency towing eyelet under the rear of the vehicle.



Emergency Towing Eyelet

A driver must be in the vehicle to steer it and operate the brakes. Towing in this manner may be done only on hard-surfaced roads for a short distance and at low speeds. Also, the wheels, axles, drive train, steering and brakes must all be in good condition.

Before towing, release the parking brake and put the transmission in neutral (manual) or "N" (automatic). The key must be in "ACC" (engine off) or "ON" (engine running).

CAUTION:

If the engine is not running, the power assist for the brakes and steering will not work so steering and braking will be much harder than usual.

IN CASE OF AN EMERGENCY

If a Retractable Headlight Does Not Operate



Turn the ignition and headlight switches off and pull out the "RTR 30 A" fuse

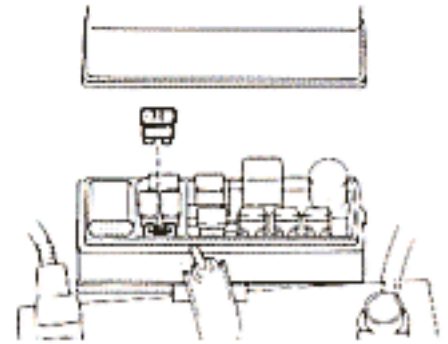

CAUTION:

Unless power is disconnected, there is danger of the headlights suddenly retracting or extending and causing injury.

To raise or lower an inoperative headlight, remove the cover from the manual operation knob next to the inoperative headlight, and turn the knob clockwise.

After the headlights are extended, turn on the light switch and check to see that the lights come on.

When the headlights are retracted, they should match the silhouette of the vehicle body.

Be sure to have the system checked by your Toyota dealer as soon as possible.

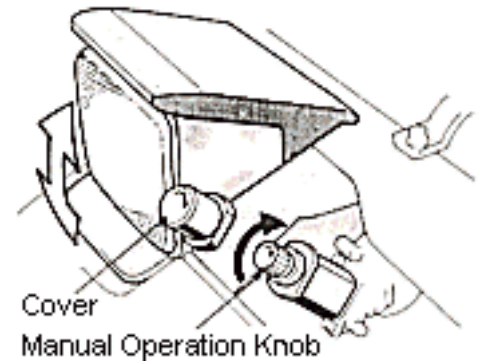

IN CASE OF AN EMERGENCY



Lost Keys

Many Toyota dealers can make a new key if you can give them the key number.

See the suggestion given in [Keys](#).

If your keys are locked in the vehicle and you cannot get a duplicate, many Toyota dealers can still open the door for you, using their special tools. If you must break a window to get in, we suggest breaking the smallest side window because it is the least expensive to replace. Be extremely cautious to avoid cuts from the glass.

CORROSION PREVENTION AND APPEARANCE CARE



1. [Protecting Your Toyota From Corrosion](#)
2. [Washing and Waxing Your Toyota](#)
3. [Cleaning the Interior](#)

CORROSION PREVENTION AND APPEARANCE CARE



Protecting Your Toyota From Corrosion

Toyota, through its diligent research, design and utilizing the most advanced technology available, has done its part to help prevent corrosion and has provided you with the finest quality vehicle construction. Now, it is up to you. Proper care of your Toyota can help ensure long-term corrosion prevention.

The most common causes of corrosion to your vehicle are:

- The accumulation of road salt, dirt and moisture in hard-to-reach areas under the vehicle.
- Chipping of paint, or undercoating caused by minor accidents or by stones and gravel.

Care is especially important if you live in particular areas or operate your vehicle under certain environmental conditions:

- Road salt or dust control chemicals will accelerate corrosion, as will the presence of salt in the air near the sea-coast or in areas of industrial pollution.
- High humidity accelerates corrosion especially when temperatures range just above the freezing point.
- Wetness or dampness to certain parts of your vehicle for an extended period of time, may cause corrosion even though other parts of the vehicle may be dry.
- High temperatures will cause corrosion to those components of the vehicle which are prevented from quick-drying due to lack of proper ventilation.

The above signifies the necessity to keep your vehicle clean as possible and to repair any damage to paint or protective coatings as soon as possible.

To help prevent corrosion on your Toyota, follow these guidelines:

Wash your vehicle frequently. It is, of course, necessary to keep your vehicle clean by regular washing, but to prevent corrosion, the following points should be observed:

- If you drive on salted roads in the winter or if you live near the ocean, you should hose off the undercarriage at least once a month to minimize corrosion.
- High pressure water or steam is effective for cleaning the vehicle's underside and wheel housings. Pay particular attention to these areas as it is difficult to see all the mud and dirt. It will do more harm than good to simply wet the mud and debris without removing them. The lower edge of doors, rocker panels and frame members have drain holes which should not be allowed to clog with dirt as trapped water in these areas can cause corrosion.
- Wash the underside of the vehicle thoroughly when winter is over.

See [Washing and Waxing Your Toyota](#).

Check the condition of your vehicle's paint and trim. If you find any chips or scratches in the paint, touch

them up immediately to prevent corrosion from starting. If the chips or scratches have gone through the bare metal, have a qualified body shop make the repair.

Check the interior of your vehicle. Water and dirt can accumulate under the floor mats and could cause corrosion. Occasionally check under the mats to make sure the area is dry. Be particularly careful when transporting chemicals, cleansers, fertilizers, salt, etc., and these should be transported in proper containers. If a spill or leak should occur, immediately clean and dry the area.

Use mud shields on your wheels. If you drive on salted or gravel roads, mud shields help protect your vehicle. Full-size shields, which come as near to the ground as possible, are the best. We recommend that the fittings and the area where the shields are installed be treated to resist corrosion. Your Toyota dealer will be happy to assist in supplying and installing the shields if they are recommended for your area.

Do not park your vehicle in a damp, poor ventilated garage. If you wash your vehicle in the garage, or if you drive it covered with water or snow, your garage may be so damp it will cause corrosion. Even if your garage is heated, a wet vehicle can corrode if the ventilation is poor.

CORROSION PREVENTION AND APPEARANCE CARE



Washing and Waxing Your Toyota

Wash your vehicle in the shade when the body is not hot to the touch. Use a mild carwash soap and rinse it well.

Dirt can cause small scratches in the paint and the chemicals in some dirt and air pollutants can cause deterioration of the paint and trim. Therefore, frequent washing is recommended. If you park or drive your Toyota near the ocean or on salted roads, it is especially important to prevent corrosion.

Your vehicle can be washed in an automatic car wash. Remember, however, that the paint surface could then be scratched with the brushes. Scratches reduce the paint's gloss retention and durability. They can become apparent easily, especially on the darker paints.

The following is the adequate procedure of car washing by hand.

1. Begin by rinsing all loose dirt off the vehicle with a hose. If the underside has picked up mud or road salt, use a hard, direct stream from a hose to remove it.
2. Wash with a commercial car-wash product available at your Toyota dealer or autoparts store. Follow the manufacturer's mixing instructions carefully. Dip your sponge or cloth into the wash bucket frequently and do not rub too hard - let the soap and water remove the dirt. To clean aluminium wheels, use only a mild soap or neutral detergent.
On plastic bumpers, remove dirt carefully and do not scrub with abrasive cleaners. The bumper face is soft.
Road tar may be removed with turpentine. Use warm water and car-wash soap for insects and tree sap. Commercial products are also available.

NOTICE:

Do not use gasoline or strong solvents, which may be toxic or cause damage.

3. Rinse the vehicle thoroughly. If any soap dries on the vehicle, it may cause streaking. In hot weather, you may have to rinse each section of the vehicle right after you wash it.
4. Dry the vehicle thoroughly. If any soap dries on the vehicle with a moist chamois or soft towel. The main purpose of drying is to remove excess water so that the vehicle will air dry without water spots. So do not rub or press hard, which might scratch the paint.
5. If you detect any stone chips or scratches in the paint, touch them up immediately to protect the bare metal from corrosion.

If you detect any stone chips or scratches in the paint, touch them up immediately to protect the bare metal from corrosion.

After washing your vehicle, make sure the brakes are fully dry before driving.

Polishing and waxing is recommended to maintain the original beauty of your Toyota's finish.

1. Always wash and dry the vehicle before you begin waxing, even if you are using a combined cleaner

and wax.

2. Use a good quality polish and wax. If the finish has become extremely weathered, use a car-cleaning polish, followed by a separate wax. Carefully follow the manufacturer's instructions and precautions. Be sure to polish and wax the chrome trim as well as the paint.
3. Wax the vehicle again when water does not bead but remains on the surface in large patches.

NOTICE:

Always remove the plastic bumpers if your vehicle is re-painted and placed in a high heat paint waxing booth. High temperatures could damage the bumpers.

Touch-up paint may be used to cover small chips or scratches.

Apply the paint soon after the damage occurs or corrosion may set in. To do a good job, use a small artist's brush and stir the paint well. Make sure the area is clean and dry. To apply the touch-up paint so it is hardly noticeable, the trick is to apply it only to the bare spots. Apply only the smallest amount possible and do not paint the surface around the scratch or chip.

CORROSION PREVENTION AND APPEARANCE CARE



Cleaning the Interior

The vinyl upholstery may be easily cleaned with a mild soap or detergent and water.

First vacuum over the upholstery to remove loose dirt. Then, using a sponge or soft cloth, apply the soap solution to the vinyl. After allowing it to soak in for a few minutes to loosen the dirt, remove the dirt and wipe off the soap with a clean damp cloth. If all the dirt does not come off, repeat the procedure. Commercial foaming-type vinyl cleaners are also available which work well. Follow the manufacturer's instructions.

NOTICE:

Do not use solvent, thinner, gasoline or window cleaner on the interior.

Use a good foam-type shampoo to clean the carpets.

Begin by vacuuming thoroughly to remove as much dirt as possible. Several types of foam cleaners are available: some are in aerosol cans and others are powders or liquids which you mix with water to produce a foam. To shampoo the carpets, use a sponge or brush to apply the foam. Rub in overlapping circles. Do not apply water - the best results are obtained by keeping the carpet as dry as possible. Read the shampoo instructions and follow them closely.

The seat belts may be cleaned with mild soap and water or with lukewarm water.

Use a cloth or sponge. As you are cleaning, check the belts for excessive wear, fraying or cuts.

NOTICE:

Do not use dye or bleach on the belts - it may weaken them.

The windows may be cleaned with any household window cleaner.

NOTICE:

When cleaning the inside of the windows, be careful not to scratch or damage the heater wires on the rear window.

Care in maintaining the surface beauty of the leather upholstery is important as improper cleaning could result in discoloration or staining.

Apply a small amount of saddle or leather soap with a soft cloth. Allow the soap solution to loosen the soil for a few minutes. Then thoroughly wipe off all the soap solution with a damp clean cloth. Use of a nylon brush, synthetic fiber cloth, etc. may scratch the fine grained surface of the leather. Never use organic substances such as benzene, alcohol and gasoline or alkaline and acid solutions for cleaning the leather as these could cause discoloring.

After cleaning or wherever any part of the leather gets wet, dry with a soft clean cloth. Allow it to air-dry in the shade with a breeze. Avoid direct sunlight.

Leather upholstery precautions

- Mildew may develop on soiled leather upholstery. Be especially careful to avoid oil spots. try to maintain your upholstery in a constant clean condition.
- Long exposure to the direct rays of the sun may cause the leather surface to harden and shrink. Keep your vehicle in a shaded area, especially in the summer.
- As the interior temperature of your vehicle is apt to rise during hot summer days avoid placing items of vinyl or plastic or containing wax on the upholstery as these tend to stick to leather when warm.

If you have any questions about the cleaning of your Toyota, your local Toyota dealer will be pleased to answer them.

MAINTENANCE REQUIREMENTS



1. [Maintenance Facts](#)
2. [Does Your Vehicle Need Repairing?](#)

MAINTENANCE REQUIREMENTS



Maintenance Facts



Regular Maintenance is Essential

We urge you to protect your new vehicle by having your Toyota serviced according to the maintenance schedule given in the separate booklet. Regular maintenance will aid:

- Good fuel economy
- Long vehicle life
- Driving enjoyment
- Safety
- Reliability
- Warranty coverage
- Compliance with government regulations

Your Toyota has been designed for economical driving and economical maintenance. Many formerly required maintenance items are no longer required or are not required as often. To make sure that your vehicle runs at peak efficiency, follow the maintenance schedule.

For full details of your maintenance schedule, read the separate "Toyota Service Booklet" or "Toyota Warranty Booklet".

Where to go for service?

It makes good sense to take your vehicle to your local Toyota dealer for service.

Toyota technicians are well-trained specialists. And they are receiving the latest service information through technical bulletins, service tips and in-dealership training programs. They learn to work on Toyotas before they work on your vehicle, rather than while they are working on it. Doesn't that seem like the best way?

Your Toyota dealer has invested a lot of money in special Toyota tools and service equipment. It helps do the job better and at less cost.

Your Toyota dealer's service department will perform all of the scheduled maintenance on your vehicle - reliably and economically.

What about do-it-yourself maintenance?

Many of the maintenance items are easy to do yourself if you have a little mechanical ability and a few basic automotive tools. Simple instructions for you to perform them are presented in [Do-It-Yourself Maintenance](#).

Note, however, that some maintenance tasks require special tools and skills. These are best performed by qualified technicians. Even if you are an experienced do-it-yourself mechanic, we recommend that repairs and maintenance be conducted by your Toyota dealer who will keep a record of maintenance on your Toyota. This

record could be helpful should you ever require Warranty Service.

The service interval for scheduled maintenance is determined by the odometer or time interval, whichever comes first, shown in the schedule.

Rubber hoses (for cooling and heater system, brake system and fuel system) should be inspected by a qualified technician, in accordance with the Toyota maintenance schedule.

They are particularly important maintenance items. have any deteriorated or damaged hoses replaced immediately. Note that rubber hoses will deteriorate with age, resulting in swelled, chafed or cracked condition.

MAINTENANCE REQUIREMENTS



Does your vehicle need repairing?

Be on the alert for changes in performance, sounds, and visual tip-offs that indicate service is needed. Some important clues are as follows:

- Engine missing, stumbling, or pinging.
- Appreciable loss of power.
- Strange engine noises.
- A leak under the vehicle (however, water dripping from the air conditioner after use is normal.)
- Change in exhaust sound. (This may indicate a dangerous carbon monoxide leak. Drive with the windows open and have the exhaust system checked immediately.)
- Flat-looking tyre; excessive tyre squeal when cornering; uneven tyre wear.
- Vehicle pulls to one side when driving straight on a level road.
- Strange noises related to suspension movement.
- Loss of brake effectiveness; spongy feeling brake or clutch pedal; pedal almost touches floor; vehicle pulls to one side when braking.
- Engine temperature continually higher than normal.
- Engine continually runs hot; oil pressure gauge stays low.

If you notice any of these clues, take your vehicle to your Toyota dealer as soon as possible. It probably needs adjustment or repair.

CAUTION:

Do not continue driving with the vehicle unchecked. It could result in serious vehicle damage and possibly personal injury.

DO-IT-YOURSELF MAINTENANCE - INTRODUCTION



- [Engine Compartment Overview](#)
 - [Fuse and Circuit Breaker Locations](#)
 - [Do-It-Yourself Service Precautions](#)
-

DO-IT-YOURSELF MAINTENANCE - INTRODUCTION

Engine Compartment Overview



Engine Compartment Overview (7M-GE engine)

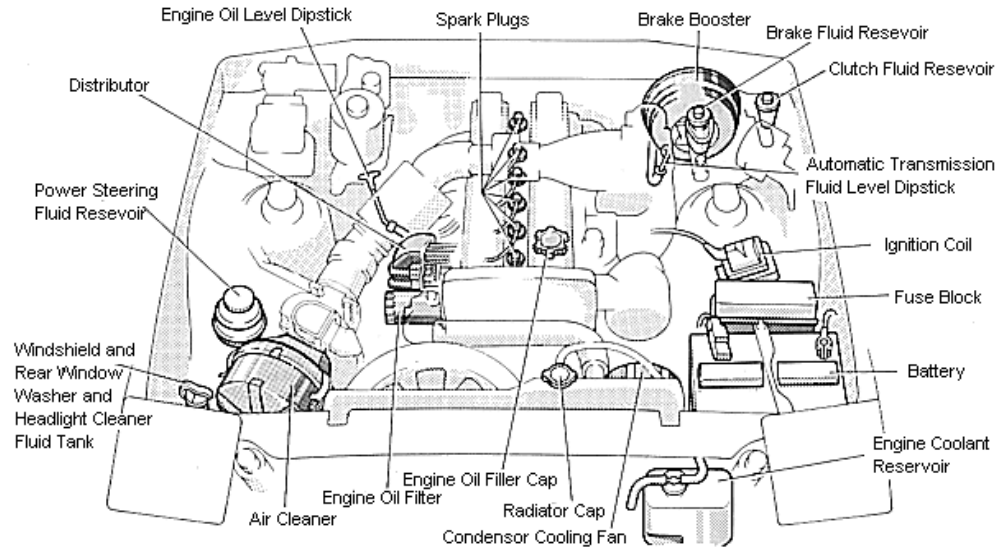

Engine Compartment Overview (7M-GTE engine)

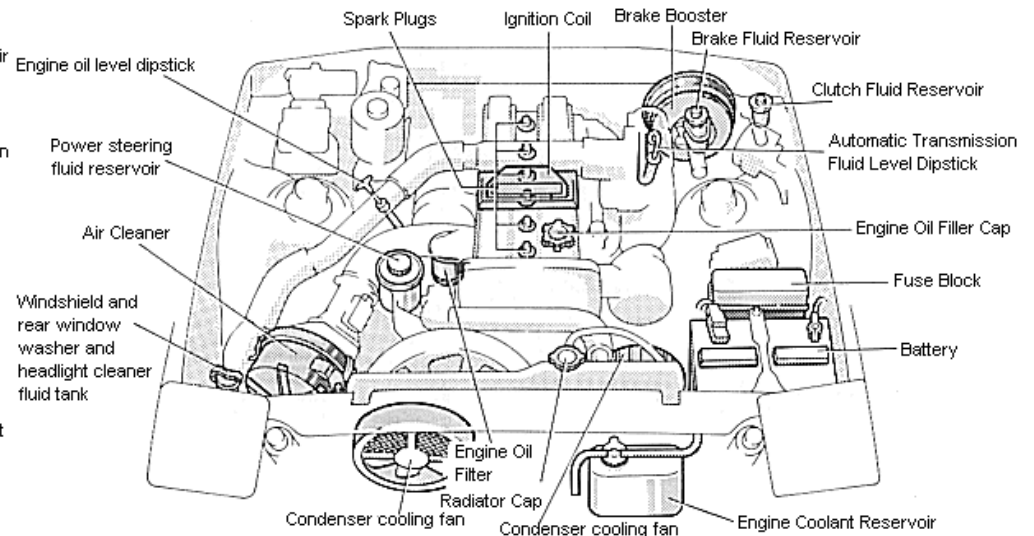

DO-IT-YOURSELF MAINTENANCE - INTRODUCTION



Fuse and circuit breaker location

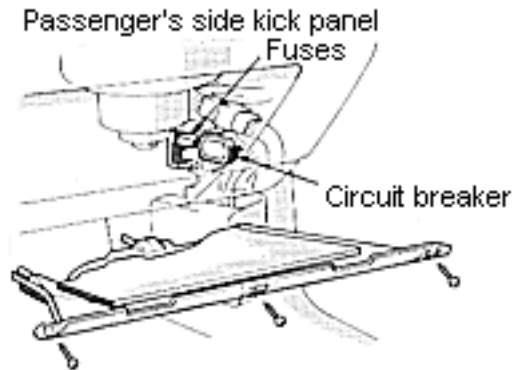
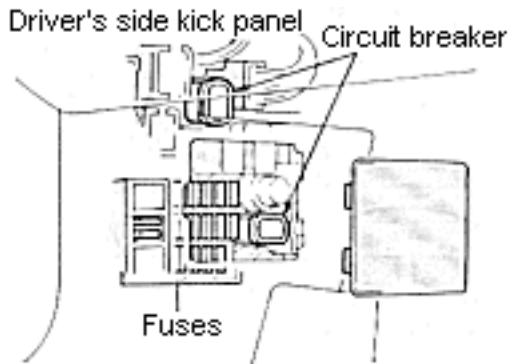
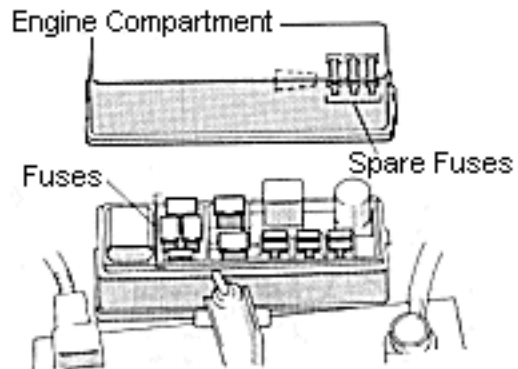
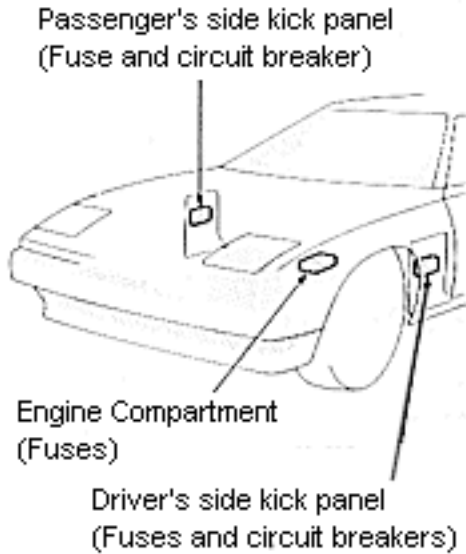

DO-IT-YOURSELF MAINTENANCE - INTRODUCTION



Do-It-Yourself Service Precautions

If you perform maintenance by yourself, be sure to follow the correct procedure given in this part.

You should be aware that improper or incomplete servicing may result in operating problems. This part gives instructions only for those items that are relatively easy for an owner to perform. As explained in [Part 6](#), there are still a number of items that must be done by a qualified technician with special tools. Utmost care should be taken when working on your vehicle to prevent accidental injury. Here are a few precautions that you should be especially careful to observe:

CAUTION:

- **When the engine is running, keep hands, clothing, and tools away from the moving fan and engine drive belt. (Removing rings, watches and tie is advisable.)**
- **Right after driving, the engine, radiator and exhaust manifold will be hot, so be careful not to touch them. Oil and fluid may also be hot.**
- **Do not smoke, cause sparks or allow open flames around fuel or battery. The fumes are flammable.**
- **Be extremely cautious when working on the battery. It contains poisonous and corrosive sulfuric acid.**
- **Do not get under your vehicle with just the body jack supporting it. Always use automotive jack stands or other solid supports.**
- **Be sure that the ignition is off if you work near the condenser cooling fans or radiator grille. With the ignition on, the condenser cooling fans will automatically start to run if the air conditioner is on.**
- **Use eye protection whenever you work on or under your vehicle where you may be exposed to flying or falling material, fluid spray, etc.**

NOTICE:

Remember that battery and ignition cables carry high currents or voltages. Be careful of accidentally causing a short circuit. When closing the engine hood, check to see that you have not forgotten any tools, rags, etc.

DO-IT-YOURSELF MAINTENANCE - ENGINE AND CHASSIS



- [Checking the Engine Drive Belts](#)
 - [Checking the Engine Oil Level](#)
 - [Changing the Engine Oil and Filter](#)
 - [Checking the Engine Coolant Level](#)
 - [Changing the Engine Coolant](#)
 - [Checking and Replacing the Air Cleaner Element](#)
 - [Checking the Clutch Pedal Freeplay](#)
 - [Checking the Brake and Clutch Fluid](#)
 - [Checking the Brake Pedal Freeplay](#)
 - [Checking the Brake Pedal Clearance](#)
 - [Checking the Parking Brake Adjustment](#)
 - [Checking the Brake Booster](#)
 - [Checking the Power Steering Fluid](#)
 - [Checking the Steering Wheel Freeplay](#)
 - [Checking Manual Transmission Oil](#)
 - [Checking Automatic Transmission Oil](#)
 - [Checking Differential Oil](#)
 - [Checking Tyre Pressure](#)
 - [Checking and Replacing Tyres](#)
 - [Rotating Tyres](#)
 - [Installing Snow Tyres and Chains](#)
 - [Replacing Wheels](#)
 - [Aluminium Wheel Precautions](#)
-

DO-IT-YOURSELF MAINTENANCE - ENGINE AND CHASSIS



Checking the Engine Drive Belts

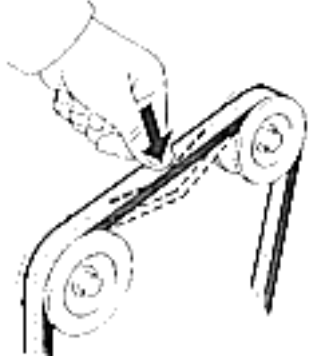

Visually inspect the condition of the drive belts. Check their tension by applying thumb pressure midway between the pulleys.

- a. With the engine turned off, check the belt for cracks, fraying, excessive wear, or oil stains. Have belts in poor condition immediately replaced by your Toyota dealer.
- b. With your thumb, press hard on each belt midway between the pulleys. Each belt should deflect no more than the amount specified in Part 8. If a belt is loose, have it adjusted by your Toyota dealer.

CAUTION:

When the engine is hot, be careful not to touch the radiator or engine.



DO-IT-YOURSELF MAINTENANCE - ENGINE AND CHASSIS

Checking the Engine Oil Level

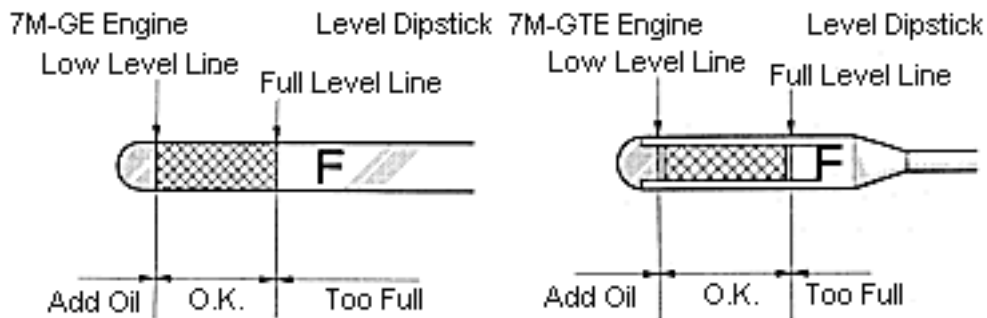

With the engine at operating temperature and turned off, check the oil level on the dipstick.

1. To get a true reading, the vehicle should be on a level spot. After turning off the engine, wait a few minutes for the oil to drain back into the bottom of the engine.
2. Pull out the dipstick, and wipe it clean with a rag.
3. Reinsert the dipstick - push it in as far as it will go, or the reading will not be correct.
4. Pull the dipstick out and look at the oil level on the end.

If the oil level is below or only slightly above the low level line, add engine oil of the same type as already in the engine.

Remove the oil filler cap and add engine oil in small quantities at a time, check the dipstick.

The approximate quantity of oil needed to fill between the low level line and the full level line on the dipstick is indicated below for reference.

When the oil level reaches within the correct range, install the filler cap hand tight.

Oil Quantity : 1.0 Litre (1.1 US Quart, 0.9 Imperial Quart)

NOTICE:

Avoid overfilling, or the engine could be damaged.

Check the oil level on the dipstick once again after adding oil.

DO-IT-YOURSELF MAINTENANCE - ENGINE AND CHASSIS



Changing the Engine Oil and Filter

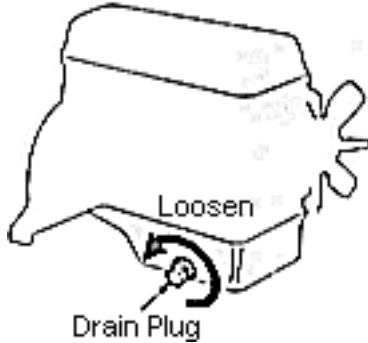

1. **Warm up the engine for a few minutes and then turn it off. Remove the oil filler cap.**

a. Park the vehicle on a level spot. Warm up the engine until the engine temperature gauge shows a rise. (Warm oil will drain faster and more thoroughly.) Turn the engine off.

b. Remove the oil filler cap. This allows air to enter the engine as the oil drains.

2. **Remove the drain plug and allow the oil to drain fully.**

a. Place a drain pan under the drain plug.

b. Using a wrench, remove the drain plug. Allow the oil to drain fully.

CAUTION:

The oil may be hot - be careful not to burn yourself.

3. **Remove the old oil filter and install a new one. Reinstall the drain plug.**

a. Using an oil filter wrench, (Any of several common types will work), loosen the oil filter. It turns counter-clockwise. Once loose you may unscrew it the rest of the way by hand. When removing it, hold up the end so that the oil does not spill out.

b. With a clean rag, wipe off the mounting surface on the engine so that the new filter will seat well. Make sure that the old gasket has not stuck to the mounting surface. If it has, remove it before installing the new filter.

c. Smear a little engine oil on the rubber gasket of the new oil filter.

d. Screw the new filter into place and tighten it until the gasket contacts the seat. Then give it an additional 3/4 turn to seat the filter with the oil filter wrench.

e. Reinstall the drain plug and a new gasket. Tighten the plug with your wrench, but do not force it and strip the threads.

CAUTION:

Be careful not to touch the hot exhaust manifold.

4. **Add oil and install the filler cap. Start the engine and check of leaks at the filter or drain plug.**

a. See the following "Engine oil selection" for proper engine oil selection. Engine oil additives are neither needed nor recommended.

b. After adding the oil, make sure that the filler cap is installed hand tight. You should double check the oil level on the dipstick.

c. With the engine running, look carefully for any small leaks from around the oil filter or drain

- plug. Any leak indicates a faulty installation.
- d. Turn the engine off and wait a few minutes. Check the oil level again and add oil if necessary.

CAUTION:

- **Used engine oil contains potential harmful contaminants which may cause skin disorders such as inflammation or skin cancer, so care should be taken to avoid prolonged and repeated contact with it. To remove engine oil from your skin, wash thoroughly with soap and water.**
- **Do not leave used oil within the reach of children.**
- **Dispose of used oil and filter only in a safe and acceptable manner. Do not dispose of used oil and filter in household trash, in sewers or on the ground. Call your dealer or a service station for information concerning recycling or disposal.**

Engine oil specification.

Use engine oil of API grade SG or better. (If it is impossible to get SG or better grade, you may use SF grade.) Recommended viscosity is as follows.

Recommended Viscosity (SAE):

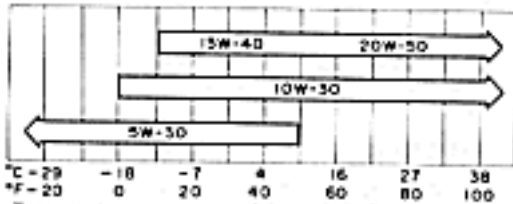

Temperature range anticipated before next oil change.

DO-IT-YOURSELF MAINTENANCE - ENGINE AND CHASSIS



Checking the Engine Coolant Level

Look at the see-through coolant reservoir tank. The coolant level is satisfactory if it is between the "FULL" and "LOW" lines on the tank. If the level is low, add coolant of the same type as already in the system.

The coolant level in the reservoir tank will vary with engine temperature. However, if the level is on or below the "LOW" line, add coolant. Bring the level up to the "FULL" line.

Always use the same type of coolant as already in the cooling system. For information on coolant, see [Changing the Engine Coolant](#).

If the coolant level drops within a short time after replenishing, there may be a leak in the system. Visually check the radiator, hoses, radiator cap, drain plug and water pump.

If no leak can be found, have the cap pressure tested at your Toyota dealer.

CAUTION:

To prevent burning yourself, do not remove the radiator cap when the engine is hot.

DO-IT-YOURSELF MAINTENANCE -

ENGINE AND CHASSIS

Changing the Engine Coolant

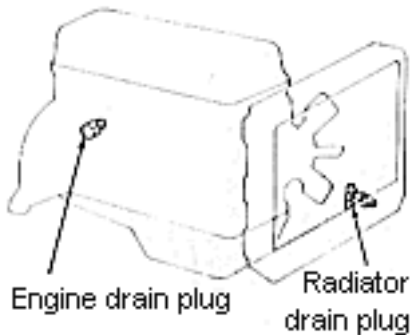

1. Drain the cooling system and flush it out with water

- a. Park the vehicle on a level spot, where the coolant can drain into a suitable disposable container.
- b. Remove the radiator cap and loosen (turn counterclockwise) the two drain plugs.

CAUTION:

To prevent burning yourself, do not remove the radiator cap or loosen the drain plugs if the engine is hot.

2. Close the two drain plugs and fill the system with coolant. Install the radiator cap.

- a. Make sure that both drain plugs are securely tightened.
- b. Pour the proper amount of antifreeze or anticorrosive into the radiator. Then fill it with clean demineralised or distilled water until the radiator is full.

NOTICE:

Add only demineralised or distilled water to fill the radiator.

- c. Wait for a few minutes and add water again in small quantities until the water level does not drop.
- d. Start the engine, and top up the radiator with water. Fill the reservoir half full.
- e. Install the radiator and reservoir caps and double-check that the drain plugs are not leaking

NOTICE:

If you spill some of the coolant, be sure to wash it off with water to prevent it from damaging the parts or the painting.

Coolant type selection

Your coolant must contain either ethylene-glycol antifreeze or anticorrosive.

Ethylene-Glycol antifreeze is the antifreeze contained in the coolant your new Toyota is delivered with. In addition to preventing freezing and subsequent damage to the engine, this will prevent corrosion.

Anticorrosive may only be used in regions where there is no possibility of the coolant freezing. Use Toyota "RADIATOR CONDITIONER" anticorrosive or equivalent.

Read the antifreeze or anticorrosive container for information on freeze or corrosion protection. Follow the manufacturer's directions for how much to mix with water. The total capacity of the coolant system is given in Part 8. As for antifreeze, we recommend 50% solution be used for your Toyota, or a sufficient quantity to provide protection to about -35°C (-31°F).

NOTICE:

Do not use alcohol type antifreeze or plain water alone.

DO-IT-YOURSELF MAINTENANCE - ENGINE AND CHASSIS



Checking and Replacing the Air Filter Element

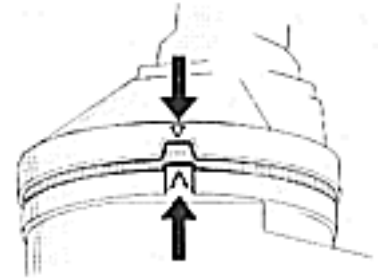
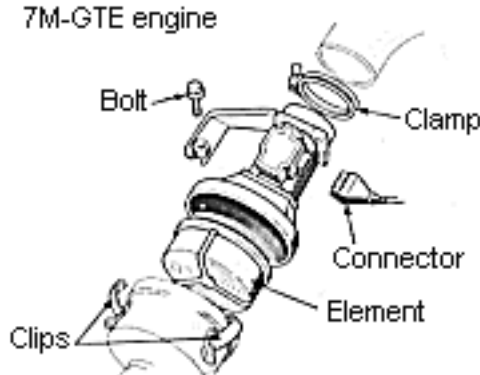
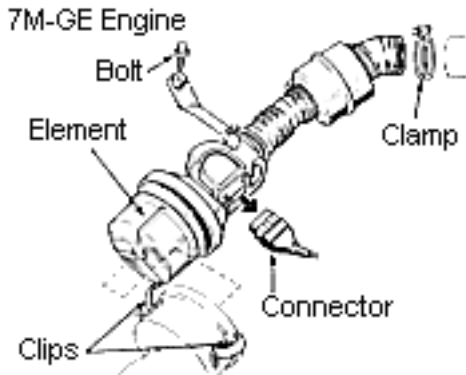

1. **To inspect the element, loosen the clamp, pull off the connector, and remove the retainer bolt. Then release the clips and take out the element.**
Inspect the outer surface of the element. If it is dirty, it should be replaced. If it is just moderately dusty, it may be cleaned by blowing compressed air from the inside. Do not wash or oil the element.
2. **To install an element, put it properly in place and reinstall the cover with the tab fitted into the cutout provided.**

Before installing, remove any dust from where the element seats.

NOTICE:

Do not drive with the air cleaner removed, or excessive engine wear could result. Also, backfiring could cause a fire in the engine compartment.

DO-IT-YOURSELF MAINTENANCE - ENGINE AND CHASSIS



Checking Clutch Pedal Freeplay

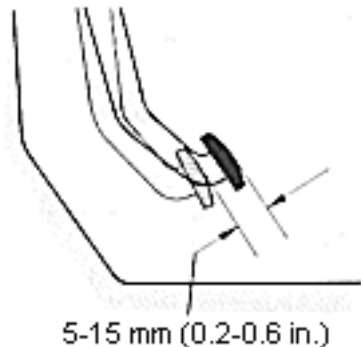

Press down lightly on the clutch pedal and measure the distance it moves freely before the clutch resistance is felt. The freeplay should be within the limits shown.

If the freeplay is more or less, have your Toyota dealer inspect the clutch.

DO-IT-YOURSELF MAINTENANCE - ENGINE AND CHASSIS



Checking Brake and Clutch Fluid

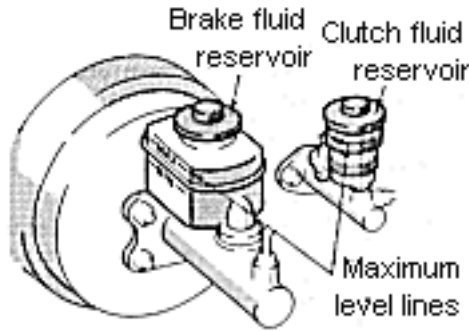

To check the fluids, simply look at the see-through reservoirs. The brake and clutch fluid levels should be within 10mm (0.4in.) and 5mm (0.2in) respectively below each maximum level line.

It is a good habit to check these fluid reservoirs every time you check the engine oil level.

It is normal for the brake fluid level to go down slightly as the pads wear. So be sure to keep the reservoir filled.

If any reservoir needs frequent refilling, it may indicate a serious mechanical problem.

If the level is low, add SAE J1703 or FMVSS No. 116 DOT 3 brake fluid to the brake or clutch reservoir.

Remove and replace the reservoir covers by hand. Fill the brake fluid to the correct level when you put the cover back on.

Use only newly opened brake fluid. Once opened, brake fluid absorbs moisture from the air, and excess moisture can cause a dangerous loss of braking. Also, for this reason, you should have the brake fluid drained and replaced periodically.

CAUTION:

Use caution in filling the reservoir, because brake fluid can harm your eyes and damage painted surfaces. If fluid gets in your eyes, flush your eyes with clean water

NOTICE:

If you spill some fluid, be sure to wash it off with water to prevent it from damaging the parts or painting.

DO-IT-YOURSELF MAINTENANCE - ENGINE AND CHASSIS



Checking Brake Pedal Freeplay

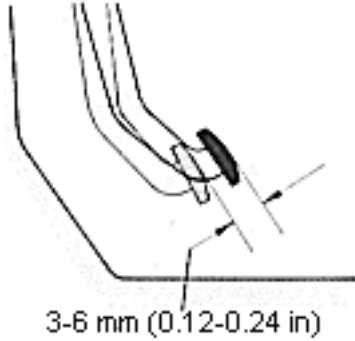

With the engine stopped, first reduce the vacuum in the booster by depressing the brake pedal several times. Then lightly and slowly press down on the pedal with your fingers and measure the distance it moves before slight resistance is felt.

If the freeplay is more or less than specification, have your Toyota dealer adjust the brakes.

DO-IT-YOURSELF MAINTENANCE - ENGINE AND CHASSIS



Checking Brake Pedal Clearance

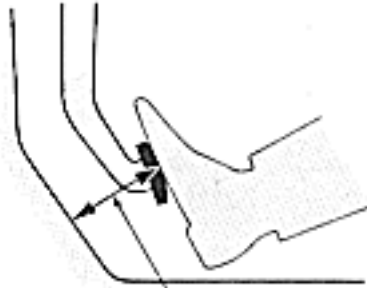

80 mm (3.1 in) minimum

With the engine running, have someone press the brake pedal several times and press hard (approximately 490 N (50 kgf, 110 lb.f) on it. The distance from the asphalt sheet to the top surface of the pedal should not be less than specified.

If the clearance is less, have your Toyota dealer adjust the brakes.

DO-IT-YOURSELF MAINTENANCE - ENGINE AND CHASSIS



Checking Parking Brake Adjustment

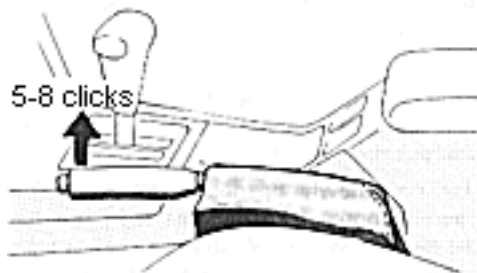

Count the number of clicks as you slowly pull on the parking brake as far as it will go (approximately 196N (20kgf, 44lb.f)). The adjustment is correct if you hear the number of clicks specified.

If you count more or less clicks, have the parking brake adjusted by your Toyota dealer.

DO-IT-YOURSELF MAINTENANCE -

ENGINE AND CHASSIS

Checking the Brake Booster



Sit in the driver's seat and follow the instructions given below. If your brakes do not operate as described, have them checked at your Toyota dealer.

1. With the engine stopped, depress the brake pedal several times: the travel distance should not change.
 2. With the brake fully depressed, start the engine: the pedal should move down a little when the engine starts.
 3. Depress the brake, stop the engine, and hold the pedal in for about 30 seconds: the pedal should neither sink nor rise.
 4. Restart the engine, run it for about a minute and turn it off. Then firmly depress the brake several times : the pedal travel should decrease with each application.
-

DO-IT-YOURSELF MAINTENANCE - ENGINE AND CHASSIS



Checking the Power Steering Fluid

7M-GE Engine

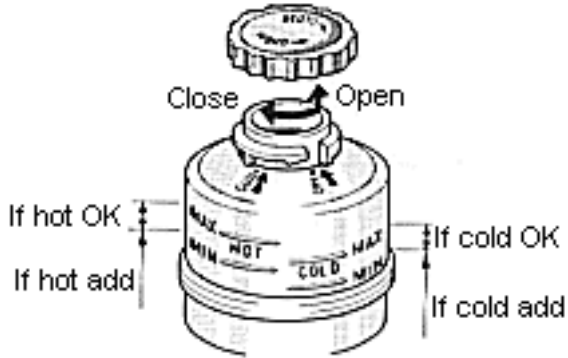

Check the fluid level through the reservoir. If necessary, add DEXRON®-II automatic transmission fluid.

If the vehicle has been driven around 80 km/h (50 mph) for about 20 minutes (a little more in frigid temperatures), the fluid is hot (60°C-80°C (140°F-175°F). you may also check the level when the fluid is cold (about room temperature, 10°C-30°C or 50°F-85°F) if the engine has not been run for about five hours.

Clean all dirt from outside of the reservoir tank and look at the fluid level. If the fluid is cold, the level should be in the "COLD" range. Similarly, if it is hot, the fluid level should be in the "HOT" range. If

the level is at the low side of either range, add DEXRON®-II automatic transmission fluid to bring the level within the range.

To remove the filler cap, turn it counterclockwise and lift up. to reinstall it, turn it clockwise. After replacing the filler cap, visually check the steering box case, vane pump and hose connections for leaks or damage.

CAUTION:

The reservoir tank may be hot so be careful not to burn yourself.

NOTICE:

Avoid overfilling, or the power steering could be damaged.

7M-GTE Engine

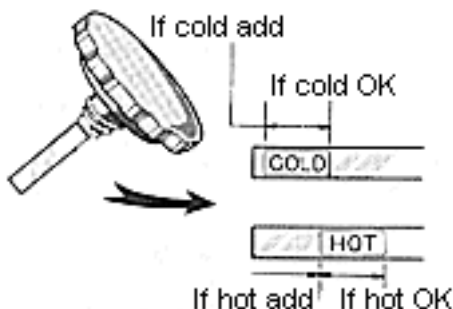

Check the fluid level on the dipstick. If necessary, add DEXRON®-II automatic transmission fluid.

If the vehicle has been driven around 80 km/h (50 mph) for about 20 minutes (a little more in frigid temperatures), the fluid is hot (60°C-80°C (140°F-175°F). you may also check the level when the fluid is cold (about room temperature, 10°C-30°C or 50°F-85°F) if the engine has not been run for about five hours.

- a. Clean all the dirt from outside of the reservoir tank.
- b. Remove the filler cap by turning it counterclockwise and wipe the dipstick clean.
- c. Reinstall the filler cap.
- d. Remove the filler cap again, and look at the fluid level. If the fluid is cold, the level should be in the "COLD" range on the dipstick. Similarly, if it is hot, the fluid level should be in the "HOT" range. If the level is at the low side of either range, add DEXRON®-II automatic transmission fluid to bring the level within the range.
- e. After replacing the filler cap, visually check the steering box case, vane pump and hose connections for leaks or damage.

CAUTION:

The reservoir tank may be hot so be careful not to burn yourself.

NOTICE:

Avoid overfilling, or the power steering could be damaged.

DO-IT-YOURSELF MAINTENANCE - ENGINE AND CHASSIS



Checking the Steering Wheel Freeplay

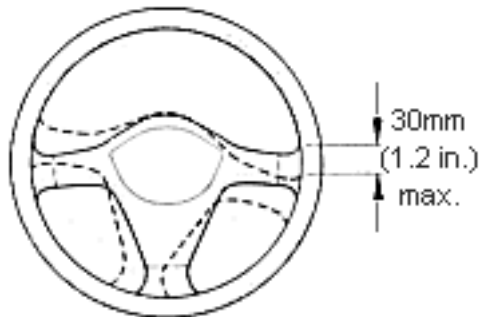

With the vehicle stopped and the front wheels pointed straight ahead, turn the steering wheel lightly to both sides. If the freeplay is more than specified, have it inspected by your Toyota dealer



DO-IT-YOURSELF MAINTENANCE - ENGINE AND CHASSIS

Checking Manual Transmission Oil

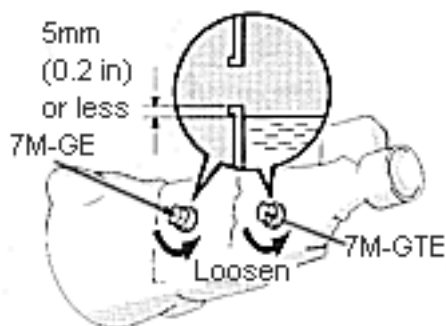

Remove the filler plug and feel inside the hole with your finger. The oil level should be no more than 5 mm (0.2 in.) below the bottom edge of the hole. If the level is O.K., reinstall the plug and tighten it.

- a. Make sure the vehicle is level while making this check.
- b. After installing the plug, visually check the transmission case for leaks or damage.

CAUTION:

Right after driving the oil may be hot, so be careful.

If the level is low, add multipurpose gear oil (API GL-4 or GL-5) until it begins to run out of the filler hole. Reinstall the plug securely.

Recommended viscosity:

7M-GE Engine

SAE 80W, 80W-90 or 75W-90

7M-GTE Engine

SAE 75W-90

- a. Fill the lubricant filler with gear oil.
- b. Put the end of the tube into the filler hole and add oil until it begins to run out.
- c. Install and retighten the filler plug.



DO-IT-YOURSELF MAINTENANCE - ENGINE AND CHASSIS

Checking Automatic Transmission Fluid

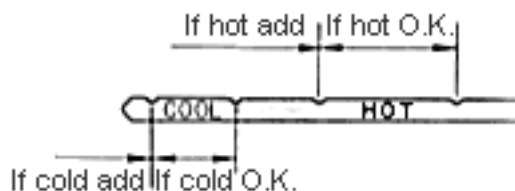

1. Check the fluid level when the transmission is hot (normal operating temperature).

If the vehicle has been driven over 16 km or 10 miles (24 km or 15 miles in frigid temperatures) and the fluid temperature is 70°C - 80°C (160°F - 175°F), the transmission is hot.

If the vehicle has just been driven for a long time at high speed or in city traffic in hot weather, or if the vehicle has been pulling a trailer, an accurate fluid level cannot be obtained. Check the level after the fluid has cooled down (about 30 minutes).

You may check the level when the transmission is cold. If the vehicle has not been driven for over five hours and the fluid is about room temperature 20°C - 30°C (70°F - 85°F), the transmission is cold. However, checking a cold transmission is to be used for your reference only and the transmission must be checked again for correct level at normal operating temperature.

2. With the vehicle level, first set the parking brake and then start the engine. While the engine is idling, depress the brake pedal and shift the selector lever into each range from "P" to "L" and return to "P". With the engine still idling, check the fluid level and condition on the dipstick.

- a. Pull out the dipstick and wipe it clean.
- b. Reinsert the dipstick - push it in as far as it will go.
- c. Pull the dipstick out and look at the fluid level. If the transmission is hot, the fluid level should be in the "HOT" range on the dipstick. Similarly, if it is cold, the level should be in the "COOL" range.
- d. While checking the fluid level, also check the condition. If the fluid is black or if it smells burnt, have it changed.

CAUTION:

When the engine is running, keep hands and clothing away from the moving fan and engine drive belts.

3. If the level is low, add DEXRON®-II automatic transmission fluid.

If the level is at the low side of either range, add DEXRON®-II automatic transmission fluid to bring the level within the range. (Fluid is added through the dipstick tube, using a funnel.)

NOTICE:

Avoid overfilling, or the transmission could be damaged.

DO-IT-YOURSELF MAINTENANCE - ENGINE AND CHASSIS



Checking Differential Oil

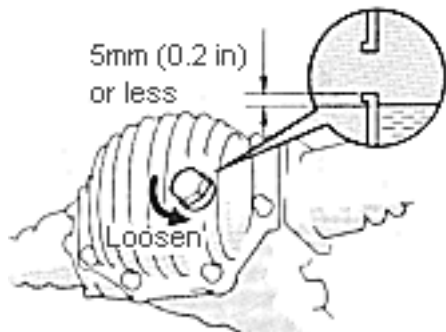

Remove the filler plug and feel inside the hole with your finger. The oil level should be no more than 5mm (0.2in.) below the bottom edge of the hole. If the level is O.K., reinstall the plug and tighten it.

- Make sure the vehicle is parked on a level spot.
- After installing the plug, visually check the differential and axle for leaks or damage.

CAUTION:

Right after driving the oil may be hot, so be careful.

If the level is low, add hypoid gear oil for limited-slip differential (API-GL5) until it begins to run out of the filler hole. Reinstall the plug.

Recommended viscosity:

Above -18°C (0°F)

SAE 90

Below -18°C (0°F)

SAE 80W or 80W90

- Fill the lubricant filler with gear oil.
- Put the end of the tube into the filler hole, and add oil until it begins to run out.
- Install and retighten the filler plug.

DO-IT-YOURSELF MAINTENANCE -

ENGINE AND CHASSIS

Checking Tyre Pressure



Keep your tyre pressures at the proper level.

The recommended cold tyre pressures and tyre sizes are given in Part 8.

You should check the tyre pressures every two weeks, or at least once a month. And don't forget the spare!

Incorrect tyre pressure can reduce tyre life and make your vehicle less safe to drive.

Low tyre pressure results in excessive wear, poor handling, reduced fuel economy, and the possibility of blowouts from overheated tyres. Also, low tyre pressure can cause poor sealing of the tyre bead. If the tyre pressure is excessively low, there is the possibility of wheel deformation and/or tyre separation.

High tyre pressure produces a harsh ride, handling problems, excessive wear at the center of the tyre tread, and a greater possibility of tyre damage from road hazards.

If a tyre frequently needs refilling, have it checked by your Toyota dealer.

The following instructions for checking tyre pressure should be observed:

- **The pressure should be checked only when the tyres are cold.** If your vehicle has been parked for at least 3 hours and has not been driven for more than 1.5 km or 1 mile since, you will get an accurate cold tyre pressure reading.
- **Always use a tyre pressure gauge.** The appearance of a tyre can be misleading. Besides, tyre pressures that are even just a few pounds off can degrade handling and ride.
- **Do not bleed or reduce tyre pressure after driving.** It is normal for the tyre pressure to be higher after driving.
- **Be sure to reinstall the tyre inflation valve caps.** Without the valve caps, dirt or moisture could get into the valve core and cause air leakage. If the caps have been lost, have new ones put on as soon as possible.

DO-IT-YOURSELF MAINTENANCE -

ENGINE AND CHASSIS

Checking and Replacing Tyres



CHECKING YOUR TYRES

Check the tyre tread for the tread wear indicators. If the indicators show, replace the tyres.

The tyres of your Toyota have built-in tread wear indicators to help you know when the tyres need replacement. When the tread depth wears to 1.6mm (0.06 in.) or less, the indicators will appear. If you can see the indicators in two or more adjacent grooves, the tyres should be replaced. The lower the tread, the higher the risk of skidding.

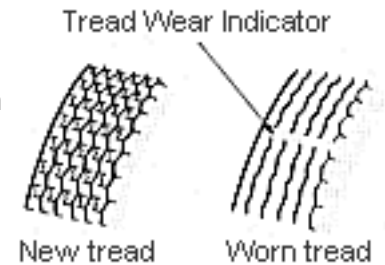

The effectiveness of snow tyres is lost if the tread wears down below 4mm (0.16 in.).

Check the tyres regularly for damage such as cuts, splits and cracks. If any damage is found, consult with a technician and have the tyre repaired or replaced.

Even if the damage does not appear serious, a qualified technician should examine the damage. Objects which have penetrated the tyre may have caused internal damage.

Any tyres which are over six years old must be checked by a qualified technician even if damage is not obvious.

Tyres deteriorate with age even if they have never or seldom been used. This also applies to the spare tyres and tyres stored for future use.

REPLACING YOUR TYRES

When replacing a tyre, use only the same size and construction as originally installed and with the same or greater load capacity.

Using any other size or type of tyre may seriously affect handling, ride, speedometer/odometer calibration, ground clearance, and clearance between the body and tyre or snow chains.

Contact your Toyota dealer for 205/55R16 spare tyres.

CAUTION:

Do not mix radial, bias belted or bias-ply tyres on your vehicle. It can cause dangerous handling characteristics, resulting in loss of control. In Germany, use of different tyre construction combinations is forbidden by SrVZO.

Never use second-hand tyres on your Toyota.

Using tyres whose previous history is unknown is a risk.

Toyota recommends all four tyres, or at least both of the front or rear tyres be replaced at a time as a set.

See [If you have a flat tyre](#) for tyre change procedure.

When a tyre is replaced, the wheel should always be balanced.

An unbalanced wheel may affect vehicle handling and tyre life. Wheels can get out of balance with regular use and should therefore be balanced occasionally.

When replacing a tubeless tyre, the air valve should also be replaced with a new one.

DO-IT-YOURSELF MAINTENANCE - ENGINE AND CHASSIS



Rotating Tyres

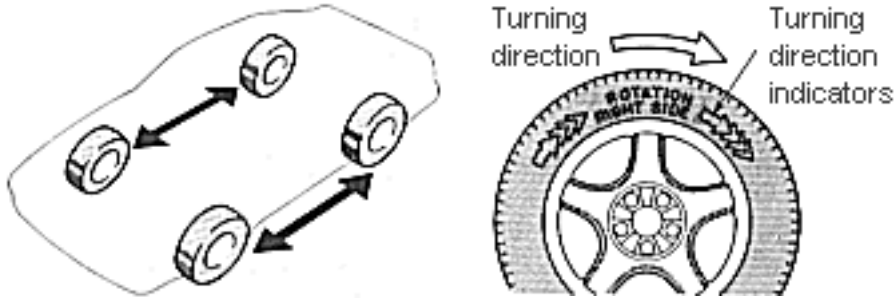

To equalise the wear of your tyres, rotate the tyres every 10000km (6000 miles).

If your tyres are marked with turning direction indicators, they are uni-directional tyre tyres and can be rotated only between the front and rear.

See [If you have a flat tyre](#) for tyre change procedure.

When rotating tyres, check for uneven wear and damage. Abnormal wear is usually caused by incorrect tyre pressure, improper wheel alignment, out-of-balance wheels, or severe braking.

CAUTION:

Do not include the 205/55R16 spare tyre when rotating the tyres. It is designed for temporary use only.



DO-IT-YOURSELF MAINTENANCE - ENGINE AND CHASSIS

Installing Snow Tyres and Chains

WHEN TO USE SNOW TYRES OR CHAINS

Snow tyres or chains are recommended when driving on snow or ice.

On wet or dry roads, conventional tyres provide better traction than snow tyres.

SNOW TYRE SELECTION

If you need snow tyres, select the 225/50R16 or 205/55R16 snow tyres for your Toyota.

Do not use tyres other than those mentioned above. Do not install studded tyres without first checking local regulations for possible restrictions.

SNOW TYRE INSTALLATION

Snow tyres should be installed on all wheels. Installing snow tyres on the rear wheels only can lead to an excessive difference in road grip capability between the front and rear tyres which could cause loss of vehicle control.

Snow tyres should be inflated as specified in Part 8.

When storing removed tyres, you should store them in a cool dry place.

Mark the direction of rotation and be sure to install them in the same direction when replacing.

CAUTION:

- **Do not drive with the snow tyres incorrectly inflated.**
- **Observe permissible maximum speed for your snow tyres and the legal speed limit.**

TYRE CHAIN SELECTION

Use the tyre chains of correct size.

Regulations regarding the use of tyre chains vary according to location or type of road, so always check them before installing chains.

CHAIN INSTALLATION

Install the chains on the rear tyres as tightly as possible. Do not use tyre chains on the front tyres. Retighten chains after driving 0.5-1.0 km (¼-½ mile).

When installing chains on your tyres, carefully follow the instructions of the chain manufacturer.

If wheel covers are used, they will be scratched by the chain band, so remove the covers before putting on the chains.

CAUTION:

- **Do not exceed 50 km/h (30 mph) or the chain manufacturer's recommended speed limit, whichever is lower.**
- **Drive carefully avoiding bumps, holes, and sharp turns, which may cause the vehicle to bounce.**
- **Avoid sharp turns of locked wheel braking as use of chains may adversely affect vehicle handling.**

DO-IT-YOURSELF MAINTENANCE - ENGINE AND CHASSIS



Replacing Wheels

WHEN TO REPLACE YOUR WHEELS

If you have wheel damage such as bends, cracks or heavy corrosion, the wheel should be replaced. If you fail to replace damaged wheels, the tyre may slip off the wheel or they may cause loss of handling control.

WHEEL SELECTION

When replacing wheels, care should be taken to ensure that the wheels are replaced by ones with the same load capacity, diameter, rim width and offset.

Correct replacement wheels are available at your Toyota dealer.

A wheel of a different size or type may adversely affect handling, wheel and bearing life, brake cooling, speedometer/odometer calibration, stopping ability, headlight aim, bumper height, vehicle ground clearance, and tyre or snow chain clearance to the body and chassis.

Replacement with used wheels is not recommended as they may have been subjected to rough treatment or high mileage and could fail without warning. Also, bent wheels which have been straightened may have structural damage and therefore should not be used. Never use an inner tube in a leaking wheel which is designed for a tubeless tyre.

DO-IT-YOURSELF MAINTENANCE -

ENGINE AND CHASSIS

Aluminium Wheel Precautions



- After driving your vehicle the first 1600 km (1000 miles), check that the wheel nuts are tight.
 - If you have rotated, repaired, or changed your tyres, check that the wheel nuts are still tight after driving 1600 km (1000 miles).
 - When using tyre chains, be careful not to damage the aluminium wheels.
 - Use only the Toyota wheel nuts and wrench designed for your aluminium wheels.
 - When balancing your wheels, use only Toyota balance weights or equivalent and a plastic or rubber hammer.
 - As with any wheel, periodically check your aluminium wheels for damage. If damaged, replace immediately.
-

DO-IT-YOURSELF MAINTENANCE - ELECTRICAL COMPONENT



- [Checking Battery Condition and Fluid Levels](#)
 - [Battery Recharging Precautions](#)
 - [Checking and Replacing Fuses](#)
 - [Checking the Circuit Breakers](#)
 - [Replacing the Windshield Wiper Blades](#)
 - [Replacing the Rear Wiper Blade](#)
 - [Adding Washer Fluid](#)
 - [Replacing Semi-Sealed Beam Headlight Bulbs](#)
 - [Replacing Front Fog Light Bulbs](#)
 - [Replacing Light Bulbs](#)
-

DO-IT-YOURSELF MAINTENANCE - ELECTRICAL COMPONENT



Checking the Battery Condition and Fluid Level

CAUTION:

BATTERY PRECAUTIONS:

The battery produces an inflammable and explosive hydrogen gas.

- Do not cause a spark from the battery with tools.
- Do not smoke or light a match near the battery.

The electrolyte contains poisonous and corrosive sulfuric acid.

- Avoid contact with eyes, skin, or clothes.
- Never ingest electrolyte.
- Wear protective safety glasses when working near the battery.
- Keep children away from the battery.

EMERGENCY MEASURES:

- If electrolyte gets in your eyes, flush your eyes with clean water for at least 15 minutes and get immediate medical attention. If possible, continue to apply water with a sponge or cloth while on route to the medical office.
- If electrolyte gets on your skin, thoroughly wash the contacted area. If you feel pain or burning, get medical attention immediately.
- If electrolyte gets on your clothes, there is a possibility of the it soaking through to your skin, so immediately take off the exposed clothing and follow the procedure above, if necessary.
- If you happen to swallow electrolyte, drink a large quantity of milk or water. Follow with Milk of Magnesia, beaten raw egg, or vegetable oil. Then go immediately for emergency help.

1. Check the battery for corroded or loose connectors, crack or loose hold-down clamps.

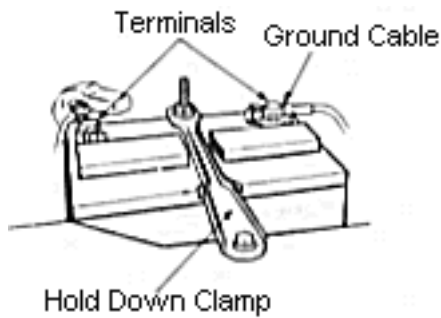

- a. If the battery is corroded, wash it off with a solution of warm water and baking soda. Coat the outside of the terminals with grease to prevent further corrosion.
- b. If the connectors are loose, tighten the clamp bolts, but do not over tighten.
- c. Tighten the hold-down clamps only enough to keep the battery firmly in place. Overtightening may damage the battery case.

NOTICE

Be sure the engine and all accessories are off before performing maintenance.

Remove the ground cable first, and reinstall it last.

Be carefull not to cause a short circuit with tools.

2. Check the indicator as shown.

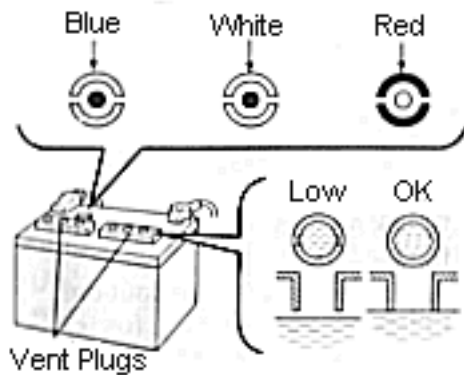

BLUE - Good Condition.

RED - Add Distilled Water.

WHITE - Charging Necessary.

If the indicator is red, check the electrolyte level as shown.

- a. When checking the electrolyte level, remove the vent plugs and look at all six cells, not just one or two.
- b. Replenish the battery with distilled water.
- c. After replenishing, be sure to securely tighten the vent plugs.

NOTICE

Do not overfill the battery or the electrolyte may squirt out of the battery during periods of heavy charging, causing corrosion or damage.

DO-IT-YOURSELF MAINTENANCE - ELECTRICAL COMPONENT

Battery Recharging Precautions



During recharging, the battery is producing hydrogen gas.

Therefore, before recharging:

1. Remove the vent plugs
2. If recharging with the battery installed on the vehicle, be sure to disconnect the ground cable.
3. Be sure the power switch on the recharger is off when connecting the charger cables to the battery and when disconnecting them.

CAUTION:

Always charge the battery in an unconfined area. Do not charge the battery in a garage or closed room where there is not sufficient ventilation.

NOTICE:

Never recharge the battery while the engine is running. Also be sure all accessories are turned off.

DO-IT-YOURSELF MAINTENANCE - ELECTRICAL COMPONENT

Checking and Replacing Fuses

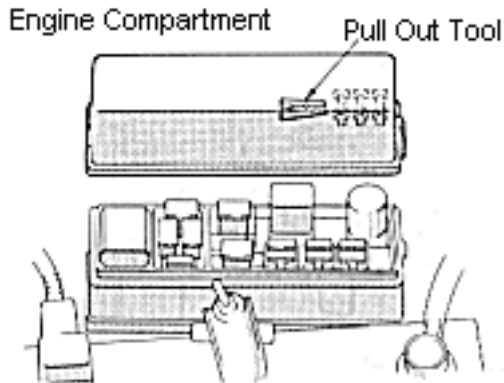

Type A



Good



Blown

Type B



Good



Blown

If the headlights or other electrical components do not work, check the fuses. If any of the fuses are blown, they must be replaced. See [Fuse and Circuit Breaker Locations](#) for locations of the fuses.

Turn the ignition switch and inoperative component off. Pull a suspected fuse straight out and check it.

Determine which fuse may be causing the problem. The lid of the fuse boxes show the name of the circuit for each fuse. See Part 8 of this manual for the functions controlled by each circuit.

Type A fuses pull out by using the pullout tool.

If you are not sure whether the fuse has blown, try replacing it with one that you know is good.

If the fuse has blown, push a new fuse into the clip.

Install only a fuse with an amperage rating designated on the fuse box lid.

If you do not have a spare fuse, in an emergency, you could pull out the "CIG", "RADIO" or "DOME" fuse, which may be dispensable for normal driving, and use it if its amperage rating is the same.

If you cannot use one of the same amperage, use one that is lower, but as close as possible, to the rating. If the amperage is lower than that specified, the fuse might blow out again, but this does not indicate that anything is wrong. Be sure to get a correct fuse as soon as possible, and return the substitute to its original clip.

It is a good idea to purchase a set of spare fuses, and keep them in your vehicle for emergencies.

If the new fuse immediately blows out, there is a problem with the electrical system. Have your Toyota dealer correct it as soon as possible.

CAUTION:

Never use a fuse with a higher amperage rating or any other object in place of a fuse. This may cause extensive damage and possibly a fire.

DO-IT-YOURSELF MAINTENANCE - ELECTRICAL COMPONENT

Checking the Circuit Breakers



In the event that the rear window defogger, air conditioner system, power windows or power door locks does not operate, check it's circuit breaker (C.B.)

See [Fuse and Circuit Breaker Locations](#) for locations of the circuit breaker.

To reset the circuit breaker, first turn the ignition switch off, and carefully insert a thin object, such as a toothpick, needle, or safety pin into the hole in the circuit breaker, until you hear a click. The component should now operate. This may be done without removing the circuit breaker.

If the circuit breaker immediately goes off again, or the component does not operate, turn off the component switch, and have the electrical system checked by your Toyota dealer as soon as possible.

See part 8 for the name of the components affected by each circuit breaker.



DO-IT-YOURSELF MAINTENANCE - ELECTRICAL COMPONENT

Replacing the Windshield Wiper Blades

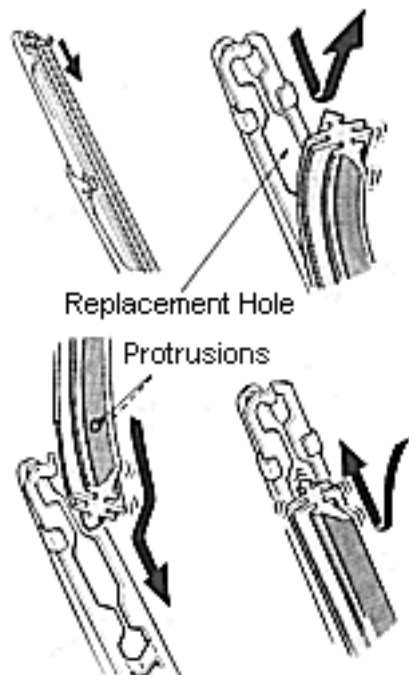

When the wipers no longer clean adequately, the wiper blades may be worn or cracked requiring replacement.

- Pull the top end of the rubber inward until the rubber blade is free of the end slot, and you can see the replacement hole.
- Pull the rubber blade out of the replacement hole.
- To install a new rubber, insert the end with small protrusions into the replacement hole, and work the rubber along the slot in the blade frame.
- Once all of the rubber is in the frame slot, allow it to expand and fill in the end.

NOTICE:

Be carefull not to scratch the glass surface with the wiper frame.

DO-IT-YOURSELF MAINTENANCE - ELECTRICAL COMPONENT



Replacing the Rear Wiper Blade

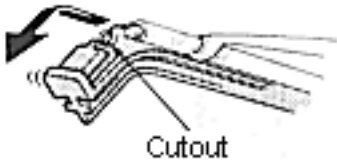

When the wipers no longer clean adequately, the wiper blades may be worn or cracked requiring replacement.



- a. Pull out the tip of the blade a little, and you will see a cutout
- b. Disengage the tip of the blade from the cutout.
- c. Slide the blade out the other end of the frame to remove it.
- d. To install a new rubber, insert the end of the blade into the slot of the frame working it in until it can go no further.
- e. Engage by stretching the tip of the blade over the end of the frame



NOTICE:

Be carefull not to scratch the glass surface with the wiper frame.

DO-IT-YOURSELF MAINTENANCE - ELECTRICAL COMPONENT



Adding Washer Fluid

If any washer does not work, the washer tank may be empty. Add washer fluid.

You may use plain water as washer fluid. However, in cold areas where temperatures range below freezing point, use washer fluid containing antifreeze. This product is available at your Toyota dealer and most auto parts stores. Follow the manufacturer's directions for how much to mix with water.

NOTICE:

Do not use engine antifreeze or any other substitute because it may damage your vehicle's paint.

DO-IT-YOURSELF MAINTENANCE - ELECTRICAL COMPONENT



Replacing Semi-Sealed Beam Headlight Bulbs

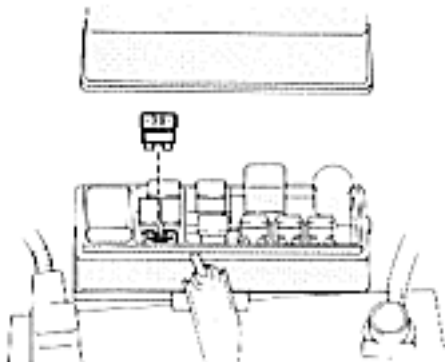

1. **Raise the headlights and turn the lights off with the headlights raised. Then pull out the "RTR 30 A" fuse.**

CAUTION:

Unless power is disconnected, there is a danger of the headlights suddenly retracting and causing injury.

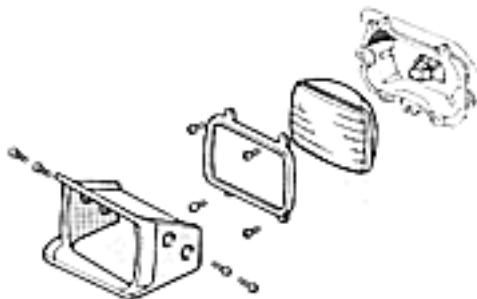

2. **Loosen the ornament screws and remove the ornament. Loosen the retainer screws and take out the beam unit together with the retainer, unplugging the connector. Remove the rubber cover.**
If the connector is tight, wiggle it.

NOTICE:

Never attempt to loosen the headlight aim adjusting screws.

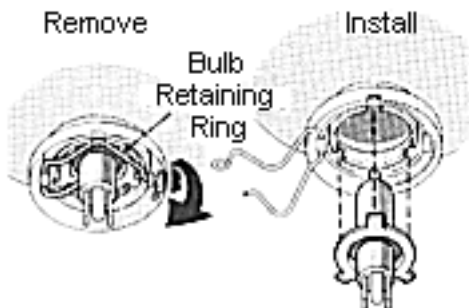

3. **Release the bulb retaining spring and remove the bulb. Install a new bulb and bulb retaining spring.**
To install a bulb, align the tabs of the bulb with the cutouts of the mounting hole.

Bulb Selection

Use a bulb with a 60/55 W (H4).

NOTICE:

Only use a bulb of the specified type above. Do not touch the glass part of the bulb with bare hands. If you do, clean the glass with alcohol and a clean rag.

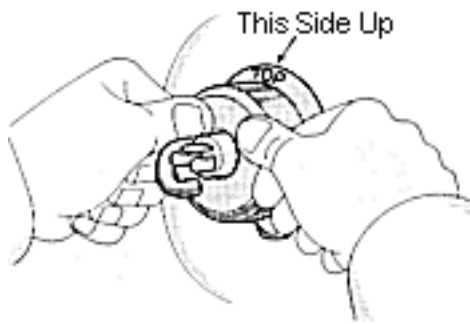

- 4. Install the rubber cover with the "TOP" mark upward. and snugle onto the boss.**

Make sure the rubber fits snugly on the bulb base and the mounting body.

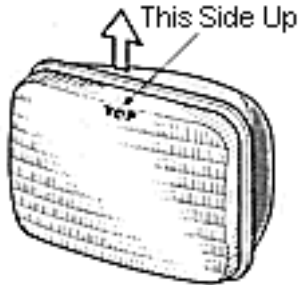

- 5. Install the unit with the "TOP" mark on the glass upward, plugging the connector. Put the retainer on the unit, tighten the screws and install the ornament. Put back the fuse.**

After replacement, have the headlight aim checked by your Toyota dealer.



DO-IT-YOURSELF MAINTENANCE - ELECTRICAL COMPONENT

Replacing Front Fog Light Bulbs

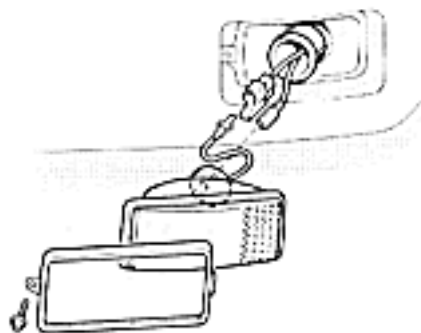

Remove

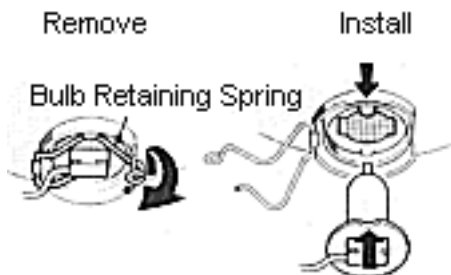

Install

1. **Loosen the retainer screw and take out the beam unit together with the retainer. Remove the rubber cover, and disconnect the cords.**

Before replacement, make sure the front fog light or driving light switch is off.

If the connector is tight, wiggle it.

2. **Release the bulb retaining spring and remove the bulb. Install a new bulb and bulb retaining spring.**

To install a bulb, align the protrusion of the bulb with the cutout of the mounting hole.

Bulb Selection

Use a bulb with a 55 W (H3).

NOTICE:

Only use a bulb of the specified type above.

Do not touch the glass part of the bulb with bare hands. If you do, clean the glass with alcohol and a clean rag.

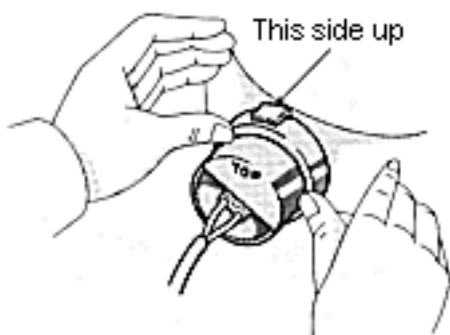

3. **Connect the cords. Install the rubber cover with the tab upward. and snuggle onto the boss.**

Make sure the rubber fits snugly on the mounting body.

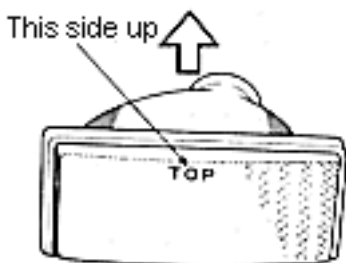

4. **Install the unit with the "TOP" mark on the glass upward, plugging the connector. Install the retainer.**



DO-IT-YOURSELF MAINTENANCE - ELECTRICAL COMPONENT

Replacing Light Bulbs

The illustrations which follow show how to gain access to the bulbs. When replacing a bulb, make sure the light switch is off. Use bulbs with the wattage rating given below.

The single end bulbs are removed by pressing in and turning counterclockwise. The double ended bulbs (*) or wedge base bulbs (**) pull straight out of the holder clips.

NOTICE:

Use only a bulb of the listed type.

No. Light Bulb	W
1 Parking Lights (**)	5
2 Front Turn Signal Lights	21
3 Side Turn Signal Lights (**)	5
4 Rear Turn Signal Lights	21
5 Stop and Tail Lights	21/5
6 Rear Fog Lights	21
7 Reversing Lights	21
8 License Plate Lights	
Side Light Type	7½
Lower Light Type (**)	5
9 Interior Lights	8
10 Glovebox Lights (**)	1.4
11 Door Courtesy Lights (*)	5
12 Luggage Compartment Lights (*)	5

Front Cluster Lights

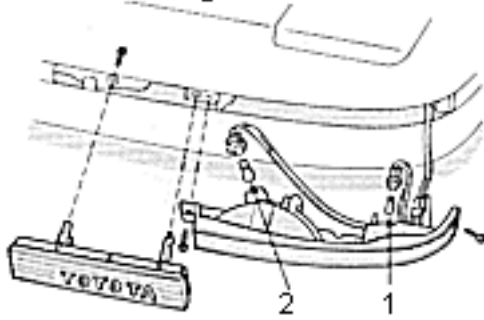

Rear Light Cluster

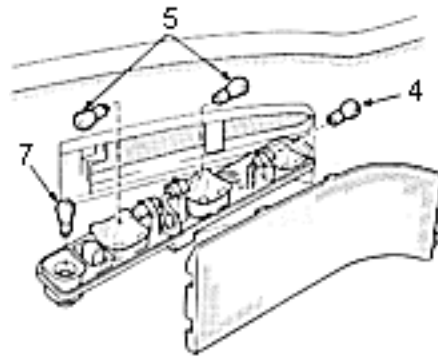

Side Turn Signal

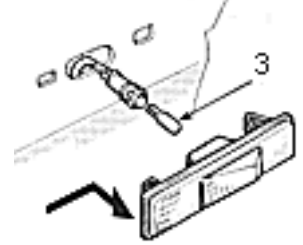

Rear Fog Light

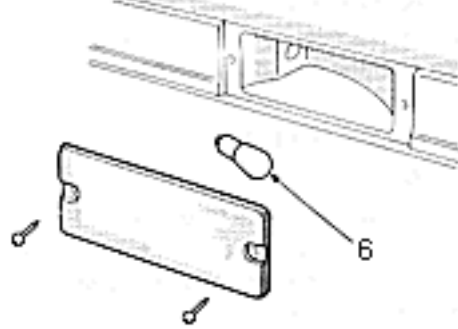

License Plate (Side)

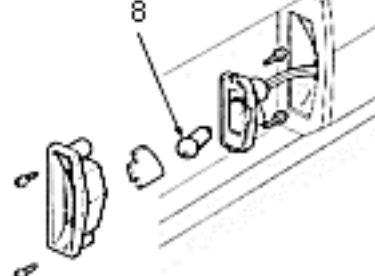

License Plate (Below)

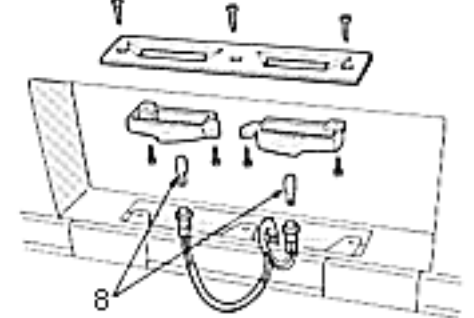

Interior Lights

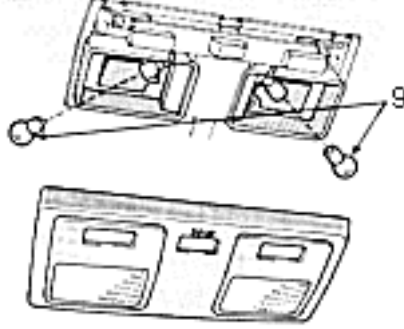

Door Light

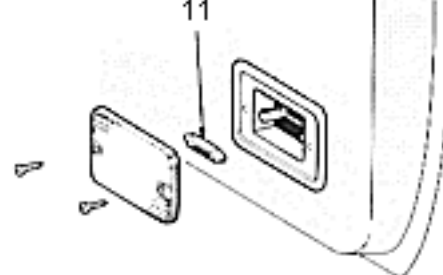

Glovebox Light

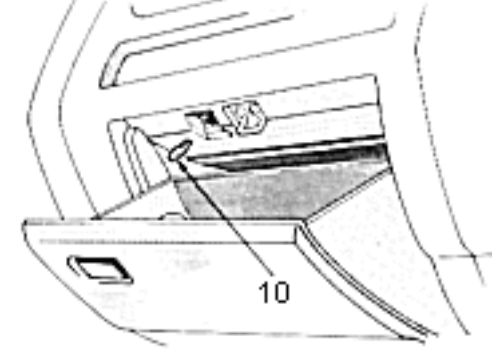

Luggage Light

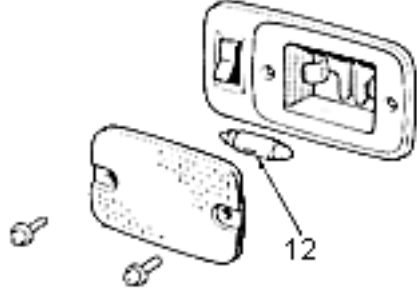

SPECIFICATIONS



- [Dimensions](#)
 - [Engine](#)
 - [Fuel](#)
 - [Service Specifications](#)
 - [Tyres](#)
 - [Fuses and Circuit Breakers](#)
-

SPECIFICATIONS



Dimensions

Overall Length mm 4620 4630 *

in. 181.9 182.3

Overall Width mm 1745

in. 68.7

Overall Height mm 1300

in. 51.2

Wheelbase mm 2595

in. 102.2

Front Tread mm 1485

in. 58.5

Rear Tread mm 1480

in. 58.3

* Vehicles with front license plate moulding.

SPECIFICATIONS

Engine



Model:

GM-GE and 7M-GTE

Type:

7M-GE engine

6 cylinder in-line, 4 cycle, gasoline.

7M-GTE engine

6 cylinder in-line, 4 cycle, gasoline, turbocharged.

Bore and Stroke, mm (in.):

83.0 x 91.0 (3.27 x 3.58)

Displacement, cm³ (cu. in.):

2954 (180.2)

SPECIFICATIONS



Fuel

Fuel type:

7M-GE engine:

For optimum engine performance, Toyota recommends using premium type unleaded gasoline with an octane number of 95 or higher (Research Octane Number).

If such premium type cannot be obtained, you may use unleaded gasoline with an octane number as low as 91.

7M-GTE engine:

Unleaded gasoline with an octane number of 97 or higher (Research Octane Number).

Fuel Tank Capacity, L (US gal, Imp gal)

70 (18.5, 15.4)

SPECIFICATIONS

Service Specifications



- [Engine](#)
- [Engine Lubrication](#)
- [Cooling System](#)
- [Battery](#)
- [Clutch](#)
- [Manual Transmission](#)
- [Automatic Transmission](#)
- [Differential](#)
- [Brakes](#)
- [Steering](#)

ENGINE

Valve Clearance (engine cold), mm (in.):

Intake 0.15 - 0.25 (0.006 - 0.010)

Exhaust 0.20 - 0.30 (0.008 - 0.012)

Spark Plug Type:

7M-GE

NIPPONDENSO PQ16R

NGK BCPR5EP11

7M-GTE

NIPPONDENSO PQ20R-P8

NGK BCPR6EP-N8

Spark Plug Gap, mm (in.):

7M-GE 1.1 (0.043)

7M-GTE 0.8 (0.031)

Drivebelt Deflection with 98 N (10 kgf, 22 lb.) thumb pressure (used belt), mm (in.):

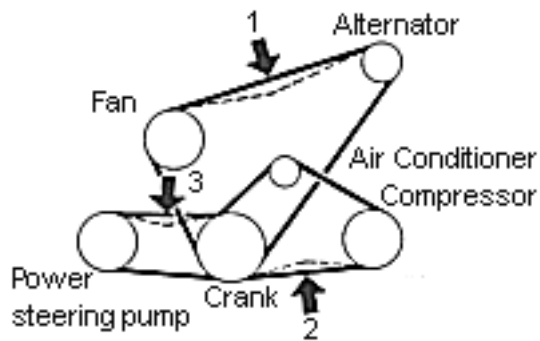

1 15.0 - 17.0 (0.59 - 0.67)

2 10.5 - 12.0 (0.41 - 0.47)

3 9.0 - 11.0 (0.35 - 0.43)

Ignition Timing

10° BTDC (with terminals E₁-TE₁ of check connector connected.)

[top](#)

ENGINE LUBRICATION

Oil Capacity, L (qt., Imp qt.):

7M-GE

Dry Fill 5.1 (5.4, 4.5)

Drain and Refill

With Filter 4.4 (4.7, 3.9)

Without Filter 4.1 (4.3, 3.6)

7M-GTE

Dry Fill 5.5 (5.8, 4.8)

Drain and Refill

With Filter 4.7 (5.0, 4.1)

Without Filter 4.4 (4.7, 3.9)

Oil Grade (API):

SG or better. (If it is impossible to get SG or better grade, you may use SF grade)

Recommended Oil Viscosity (SAE):

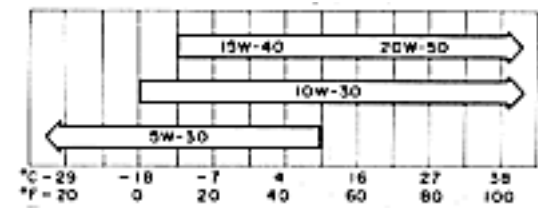

Temperature range expected before next oil change.

[top](#)

COOLING SYSTEM

Total Capacity, L (qt. Imp qt):

7M-GE 8.1 (8.6, 7.1)

7M-GTE Manual 8.2 (8.7, 7.2)

7M-GTE Automatic 8.1 (8.6, 7.1)

Coolant Type:

With Ethylene Glycol antifreeze or anticorrosive (Toyota "Radiator Conditioner" anticorrosive or equivalent)

Do not use alcohol type antifreeze.

[top](#)

BATTERY

Specific Gravity Reading at 20°C (68°F)

1.260 Fully Charged

1.160 Half Charged

1.060 Discharged

Charging Rates.

Quick Charge 15 A max

Slow Charge 5 A max

[top](#)

CLUTCH

Pedal Freeplay, mm (in.):

5 - 15 (0.2 - 0.6)

Fluid Type

SAE J1703 or FMVSS No 116 DOT 3

[top](#)

MANUAL TRANSMISSION

Oil Capacity L (qt, Imp qt)

7M-GE 2.4 (2.5, 2.1)

7M-GTE 3.0 (3.2, 2.6)

Oil Type:

Multipurpose gear oil API GL-4 or GL-5

Recommended Viscosity

7M-GE

SAE 80W, 80W-90 or 75W-90

7M-GTE

SAE 75W-90

[top](#)

AUTOMATIC TRANSMISSION

Fluid Capacity L (qt, Imp qt)

Dry Fill 7.2 (7.6, 6.3)

Drain and Refill <1.6 (1.7, 1.4)

Fluid Type:

Automatic Transmission Fluid DEXRON®-II

[top](#)

DIFFERENTIAL

Oil Capacity L (qt, Imp qt):

1.3 (1.4, 1.1)

Oil Type :

Hypoid Gear Oil for Limited Slip Differential API GL-5

Recommended Viscosity

below -18°C SAE 80W or 80W-90

above -18°C SAE 90

[top](#)

BRAKES

Minimum Brake Pedal Clearance when depressed, mm (in.):

80 (3.1)

Pedal Freeplay, mm (in.):

3 - 6 (0.12 - 0.24)

Parking Brake Adjustment

5 - 8 clicks

Fluid Type

SAE J1703 or FMVSS No 116 DOT 3

[top](#)

STEERING

Wheel Freeplay

Less than 30mm (1.2 in.)

Power Steering Fluid Type

Automatic Transmission Fluid DEXRON®-II

[top](#)

SPECIFICATIONS



Tyres

Tyre Size

Conventional Tyre

Spare Tyre

225/50ZR16

205/55R16

Except Spare Tyre

225/50ZR16

Snow Tyre

225/50R16

205/55R16

Tyre Pressure, kPa (kg/cm² or bar, psi)

Conventional Tyre

225/50ZR16

Over 210 km/h (130mph)

For all loads including full rated loads (4 or 5 passengers)

Front 300 (3.0, 44)

Rear 320 (3.2, 46)

For reduced loads (1-3 passengers)

Front 260 (2.6, 38)

Rear 280 (2.8, 41)

Under 210 km/h (130 mph)

For all loads including full rated loads (4 or 5 passengers)

Front 270 (2.7, 39)

Rear 290 (2.9, 42)

For reduced loads (1-3 passengers)

Front 230 (2.3, 33)

Rear 250 (2.5, 36)

205/55R16

250 (2.5, 36)

Snow Tyre

225/50R16

Front 230 (2.3, 33)

Rear 250 (2.5, 36)

205/55R16

250 (2.5, 36)

8 Tyres

Wheel Nut Torue, N.m (kgf.m, ft.lb)

103 (10.5 , 76)

SPECIFICATIONS

Fuses and Circuit Breakers



LHD Vehicles (ex. Germany)

Vehicles sold in Germany

Right Hand Drive Vehicle

Engine Compartment

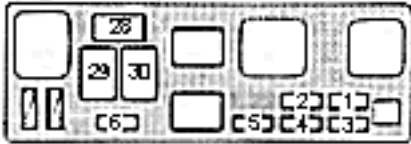

Engine Compartment

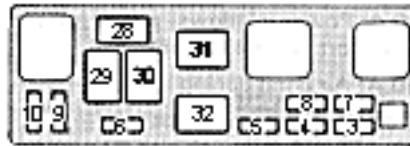

Engine Compartment

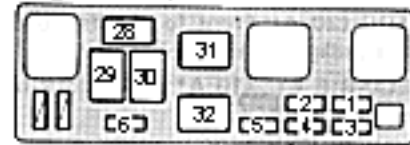

Driver's Side Kick Panel

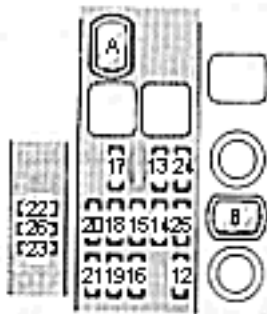

Driver's Side Kick Panel

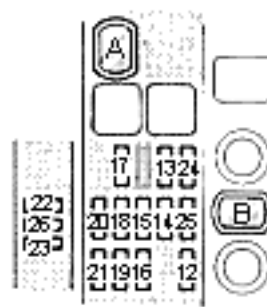

Driver's Side Kick Panel

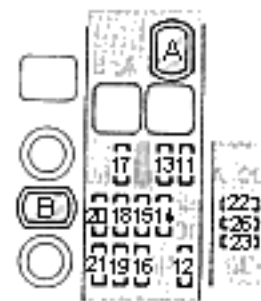

Passenger's Side Kick Panel



Passenger's Side Kick Panel



Passenger's Side Kick Panel



Fuses (type A)

1. **HEAD (RH) 15 A:** Right-hand headlight, Front fog lights.
2. **HEAD (LH) 15 A:** Left-hand headlight, Front fog lights.
3. **EFI 15 A:** Electronic Fuel Injection system.
4. **DOME 20 A:** Interior lights, door courtesy lights, luggage compartment light, step light, ignition switch light, clock, open door warning light, radio, cassette tape player, power antenna, air conditioning system, electronically controlled automatic transmission system, gauges and meters.
5. **HAZ-HORN 15 A:** Emergency flashers, horns.
6. **RTR 30 A:** Retractable headlight system.
7. **HEAD HI (RH) 15 A *3:** Right-hand headlight (high beam)
8. **HEAD HI (LH) 15 A *3:** Left-hand headlight (high beam)
9. **HEAD LO (RH) 15 A *3:** Right-hand headlight (low beam)
10. **HEAD LO (LH) 15 A *3:** Left-hand headlight (low beam)
11. **TAIL 15 A:** Tail lights, parking lights, front fog lights, license plate lights, instrument panel lights, glovebox light.
12. **IGN 7.5 A:** Charging system, discharge warning light, electronic fuel injection system.
13. **STOP 20 A *2 (15 A *1):** Stoplight, cruise control system cancel device, anti-lock brake system.
14. **MIR-HTR 10 A:** Outside rear view mirror defogger.
15. **TURN 7.5 A:** Turn signal lights, emergency flashers.
16. **ECU-IG 15 A:** Cruise control system, electronically controlled automatic transmission system, anti-lock

brake system, power steering system, retractable headlight system, power door lock system, power antenna.

17. **GAUGE 7.5 A:** Gauges and meters, warning lights and buzzer (except discharge and open door warning lights), econodrive monitor, reversing lights, air conditioning system, electronically controlled automatic transmission system, rear window defogger, power windows, power door lock system, power antenna.
18. **RADIO 7.5 A:** Radio, cassette tape player, power rear view mirrors.
19. **WIPER 20 A:** Windshield wipers and washer, rear window wiper and washer, headlight cleaner.
20. **CIG 15 A:** Cigarette lighter, digital clock display, power antenna, air conditioning system.
21. **ENGINE 15 A:** Charging system.
22. **FOG 20 A:** Front fog lights, rear fog lights, headlight beam level control.
23. **ECU-B 5 A*1 (10 A*2):** Anti-lock brake system.
24. **TAIL (RH) 10 A:** Right-hand tail light, instrument panel lights, glovebox light.
25. **TAIL (LH) 10 A:** Left-hand tail light, left-hand license plate light.
26. **SEAT HTR 15 A:** Seat heaters
27. **10 A:** Air conditioning system.

Fuses (type B)

28. **ALT 100 A:** Retractable headlight system, air conditioning system, charging system, "[CDS](#)", "[FOG](#)", "[ECU-B](#)"
29. **ABS 60 A:** Anti-lock brake system.
30. **CDS 40 A:** Condenser cooling fans.
31. **AM1 40 A:** Charging system, headlight cleaner, power windows, power lumbar and side support control system, "[CIG](#)", "[RADIO](#)", "[GAUGE](#)", "[WIPER](#)", "[TURN](#)", "[ECU-IG](#)", "[SEAT HTR](#)"
32. **AM2 30A:** Electric fuel injection system, ignition system.

Circuit breakers

- A. **30 A:** Rear window defogger.
- B. **30 A:** Power windows, power lumbar and side support control system.
- C. **40 A:** Air conditioning system.

*1: Left-hand drive vehicles

*2: Right-hand drive vehicles

*3: Vehicles sold in Germany

DO-IT-YOURSELF MAINTENANCE



- [Introduction](#)
 - [Engine and Chassis](#)
 - [Electrical Components](#)
-

IN CASE OF AN EMERGENCY

If Your Vehicle Needs to be Towed



If towing is necessary, we recommend you have it done by your Toyota dealer or a commercial tow truck service.

Proper equipment will help ensure that your vehicle is not damaged while being towed. Commercial operators are generally aware of the state/provincial and local laws pertaining to towing.

Your vehicle can be damaged if it is towed incorrectly. Although most operators know the correct procedure, it is possible to make a mistake. To avoid damage to your vehicle, make sure the following few precautions are observed. If necessary, show this page to the tow truck driver.

TOWING PRECAUTIONS

Use a safety chain system for all towing, and abide by the state/provincial and local laws. The wheels and axle on the ground must be in good condition. If they are damaged, use a towing dolly.

(a) Using flat bed truck

Toyota recommends this as the best method for your vehicle.

(b) Towing with wheel lift type truck

From front ...

- Manual Transmission:

We recommend using a towing dolly under the rear wheels. If you do not use a towing dolly, release the parking brake and put the transmission in neutral.

- Automatic transmission:

Use a towing dolly under the rear wheels.

NOTICE:

Never tow a vehicle with an automatic transmission from the front with the rear wheels on the ground, as this may cause serious damage to the transmission.

From rear ... Place the ignition key in the "ACC" position.

NOTICE:

Do not tow with the key removed or in the "LOCK" position, as the steering lock mechanism is not strong enough to hold the front wheels straight while towing.

(a) Using flat bed truck



(b) Towing with wheel lift type truck

... from front



... from rear



(c) Towing with sling type truck



(c) Towing with sling type truck

From front ...

NOTICE:

Do not tow with sling type truck. This may cause body damage.

From rear ...Follow the instructions for towing from rear in [Towing with Wheel Lift Type Truck](#).

Emergency towing (Germany)

If towing service is not available in an emergency, your vehicle may be temporarily trailed by a cable secured to the emergency towing eyelet through the front bumper.

A driver must be in the vehicle to steer it and operate the brakes. Towing in this manner may be done only on hard-surfaced roads for a short distance and at low speeds. Also, the wheels, axles, drive train, steering and brakes must all be in good condition.

Before towing, release the parking brake and put the transmission in neutral (manual) or "N" (automatic). The key must be in "ACC" (engine off) or "ON" (engine running).



Emergency Towing Eyelet

CAUTION:

If the engine is not running, the power assist for the brakes and steering will not work so steering and braking will be much harder than usual.

STARTING AND DRIVING

Starting and Stopping the engine



Before starting the engine.

1. Check the area around the vehicle before entering it.
2. Adjust [seat position](#), [seatback angle](#), and [headrest height](#) and [steering wheel angle](#).
3. Adjust [inside](#) and [outside rear view mirrors](#).
4. Close all doors.
5. Fasten [seat belts](#).

How to start the engine

a. Before cranking

1. Apply the [parking brake](#) firmly
2. Turn off unnecessary [lights](#) and [accessories](#)
3. **Manual Transmission**

Press the clutch pedal to the floor and shift the transmissio into neutral. Hold the clutch pedal to the floor until the engine is started.

Automatic Tranmission

Put the selector lever in "P". If you need to restart the engine while the vehicle is moving, put the selector lever in "N". A starter safety device will prevent the started from operating if the selector lever is in any drive position.

4. [Automatic Transmission](#) only

Depress the brake pedal and hold it to the floor until driving off.

b. Starting the engine

Before starting the engine, be sure to follow the instructions in [Before cranking](#).

Normal starting procedure.

The electronic furl injection system in your engine automatically controls the proper air-fuel misture for starting. You can start a cold or hot engine as follows:

1. With your foot off the accelerator pedal, crank the engine by turning the key to ["START"](#).
Release it when the engine starts.
2. After the engine runs for about 10 seconds, you are ready to drive.

If the weather is below freezing, let the engine warm up for a few minutes before driving.

If the engine stalls...

Simply restart it, using the correct procedure given in [norml starting](#).

If the engine will not start ...

See "If the engine will not start" in Part 4.

NOTICE:

- **Do not crank for more than 15 seconds at a time. This may overheat the starter and wiring systems.**
- **Do not race a cold engine.**
- **If the engine becomes difficult to start or stalls frequently, have the engine checked immediately.**

Precautions for turning off a turbo engine (7M-GTE engine).

After high-speed or extended driving etc., requiring a heavy engine load, the engine should be allowed to idle as shown in the chart, before turning it off.

Driving condition and required idling time.

Normal city driving.

Idling time -- Not necessary

High-speed driving.

About 80 km/h (50 mph)

Idling time -- About 20 seconds

About 100 km/h (63 mph)

Idling time -- About 1 minute

Above 100 km/h (63 mph)

Idling time -- About 2 minutes

Steep mountain slopes driving.

Idling time -- About 2 minutes

NOTICE:

Never turn the engine off immediately after a heavy load. This may cause severe engine damage.

STARTING AND DRIVING

Starting and Stopping the engine



Before starting the engine.

1. Check the area around the vehicle before entering it.
2. Adjust [seat position](#), [seatback angle](#), and [headrest height](#) and [steering wheel angle](#).
3. Adjust [inside](#) and [outside rear view mirrors](#).
4. Close all doors.
5. Fasten [seat belts](#).

How to start the engine

a. Before cranking

1. Apply the [parking brake](#) firmly
2. Turn off unnecessary [lights](#) and [accessories](#)
3. **Manual Transmission**

Press the clutch pedal to the floor and shift the transmissio into neutral. Hold the clutch pedal to the floor until the engine is started.

Automatic Tranmission

Put the selector lever in "P". If you need to restart the engine while the vehicle is moving, put the selector lever in "N". A starter safety device will prevent the started from operating if the selector lever is in any drive position.

4. [Automatic Transmission](#) only

Depress the brake pedal and hold it to the floor until driving off.

b. Starting the engine

Before starting the engine, be sure to follow the instructions in [Before cranking](#).

Normal starting procedure.

The electronic furl injection system in your engine automatically controls the proper air-fuel misture for starting. You can start a cold or hot engine as follows:

With your foot off the accelerator pedal, crank the engine by turning the key to "[START](#)". Release it when the engine starts.

Engine should be warmed up by driving, not in idle. For warming up drive with smoothly turning engine until engine temperature is within normal range.

If the engine stalls...

Simply restart it, using the correct procedure given in [norml starting](#).

If the engine will not start ...

See [If the engine will not start.](#)

NOTICE:

- **Do not crank for more than 15 seconds at a time. This may overheat the starter and wiring systems.**
 - **Do not race a cold engine.**
 - **If the engine becomes difficult to start or stalls frequently, have the engine checked immediately.**
-

Precautions for turning off a turbo engine (7M-GTE engine).

After high-speed or extended driving etc., requiring a heavy engine load, the engine should be allowed to idle as shown in the chart, before turning it off.

Driving condition and required idling time.

Normal city driving.

Idling time -- Not necessary

High-speed driving.

About 80 km/h (50 mph)

Idling time -- About 20 seconds

About 100 km/h (63 mph)

Idling time -- About 1 minute

Above 100 km/h (63 mph)

Idling time -- About 2 minutes

Steep mountain slopes driving.

Idling time -- About 2 minutes

NOTICE:

Never turn the engine off immediately after a heavy load. This may cause severe engine damage.

OPERATION OF INSTRUMENTS AND CONTROLS

AM/FM radio with electronic tuner and cassette tape player (type A)

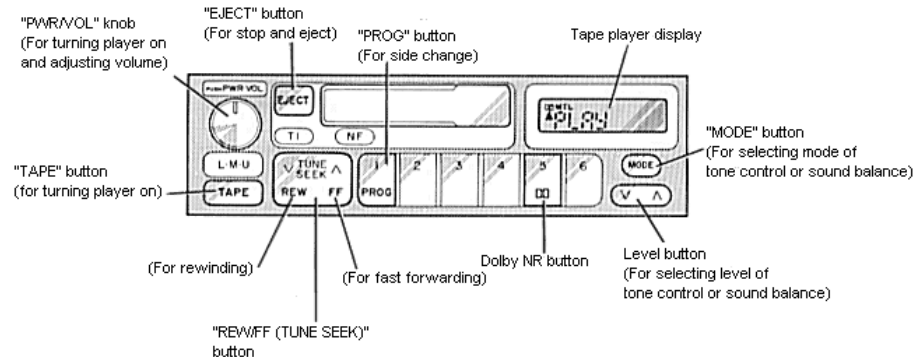
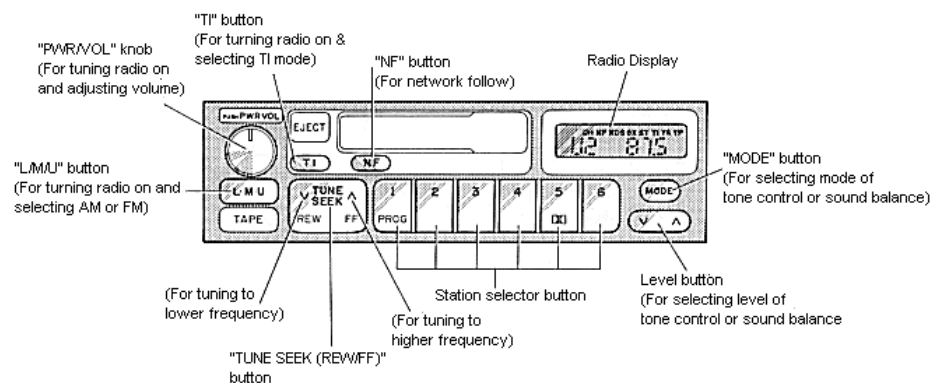

(a) Listening to the radio

1. Push the "L/M/U" button to turn the radio on and select either an AM or FM broadcast, or push the "TI" button to receive a TI (Traffic Information) station. (See [Receiving traffic information from the RDS \(Radio Data System\)](#).)
"L", "M", or "U" will appear on the display.
The radio can also be turned on by pushing the "PWR/VOL" knob if the radio was on when the system was turned off.
2. Turn the "PWR/VOL" knob to adjust the volume.
3. Tune in the desired station. (See [Selecting a station](#) and [Presetting a station](#).)
The radio will change automatically to stereo reception when an FM stereo broadcast is being received. At the same time, "ST" will appear on the display. When the receiving signal gets weak, the channel separation will automatically be reduced for the lowest noise. If the signal becomes extremely weak, the radio will switch over to monaural reception.
4. Adjust the tone and sound balance (See [Adjusting the tone](#) and [Adjusting the sound balance](#).)
5. To turn the radio off, push the "PWR/VOL" knob.

(b) Selecting a station

Tune in the desired station using one of the following methods. The frequency will appear on the display.

Preset tuning:

Use for tuning-in to a desired present station. (See [Presetting a station](#).)

1. Push the "L/M/U" button repeatedly until the desired selection appears on the display.
2. Push the station selector button which has been preset to the desired station. The radio will tune in to the station and the button number will appear on the display.

Seek tuning:

Use for automatic station search and stop.

Push the "TUNE SEEK (REW/FF)" button on either side and hold it until a beep is heard. The radio will begin seeking up or down for a station of the nearest frequency and will stop on reception. Each time you push the button, stations will be sought out one after another.

If the radio cannot seek out any stations in one pass because of too weak signals, the radio will begin seeking again with sensitivity boosted for searching out weak stations. At this time, "DX" will appear on the display.

Manual tuning:

Push the "TUNE SEEK (REW/FF)" button on either side within 0.5 second. Each time you push the button, the radio will step up or down to another frequency where stations could exist.

(c) Presetting a station

1. Push the "L/M/U" button repeatedly until the desired selection, "L", "M", or "U" appears on the display.
You can preset any desired six stations in each selection. When you preset a station, check which selection you have used.
2. Tune in the desired station. (See [Selecting a station](#).)
3. Push one of the station selector buttons and hold it until a beep is heard. This sets the station to the button and the button number will appear on the display.

I-7 AM/FM radio with electronic tuner and cassette tape player (type A)

To change the preset station to a different one, follow the same procedure.

The preset station will be cancelled when the power source is severed (battery disconnected, burnt fuse, etc.)

(d) Receiving traffic information from the RDS (Radio Data System)

1. The radio will automatically switch to the RDS mode to receive an RDS station while tuned to FM broadcasts. At this time, "RDS" and the name of the RDS station will appear on the display.

When you tune in a new FM station with RDS mode, the new frequency will appear on the display for 5 seconds before the name appears.

2. Tune in the desired station that broadcasts traffic information by using one of the following methods. When the radio receives a station which broadcasts traffic information, "TP" (Traffic Program) will also appear on the display. You can then listen to regular programs and to traffic information between the regular programs.

Preset tuning, seek tuning and manual tuning:

Use for tuning-in to a desired station. (See [Selecting a station.](#))

TI (Traffic Information) tuning:

Use for receiving TI stations all over the band.

- a. The radio is switched to the TI mode by pushing the "TI" button. At this time, "TI" will appear on the display.

If the radio does not receive a TI station for 20 seconds after the "TI" button is pushed, the radio will begin seeking a TI station by using the AF (Alternative Frequencies) list from the TI station and will stop on receiving a TI station. A beep will sound and "SEARCH" will appear on the display to tell you when this feature starts operation.

If the radio cannot find any station in one pass because the signals are too weak, the radio will begin seeking again with sensitivity boosted to search out weak stations. At this time, "DX" will appear on the display. If the signal gets extremely weak, the radio will stop seeking a station and "NOTHING" will appear on the display for 2 seconds. After this, if the radio cannot receive a TI station for 20 seconds, the radio will begin seeking again.

When "TI" appears on the display, the radio will receive a TI station only if seek tuning is used.

- b. If the selected station is broadcasting another program when traffic information is desired, push the "TI" button until "TA" (Traffic Announcement) appears. When "TA" appears on the display, the radio mutes all programs but the traffic program, or, if a cassette is inserted in the slot, the cassette will be played until traffic information begins. When the traffic information ends or the signal gets weak, the initial programming is resumed.

- c. To return to normal mode from the TI mode, push the "TI" button until "TI" and "TA" disappear from the display.

RDS auto tuning:

Use for seeking RDS stations all over the band.

- a. Push the "NF" (Network Follow) button for less than 2 seconds to receive the same program while tuning in an RDS station. At this time, "NF" will appear on the display. When reception conditions worsen, a network which broadcasts the same program will be selected using the AF list from the RDS station.

To change the NF mode, push the "NF" button for at least 2 seconds. When "REG ON" appears on the display, the radio will select the RDS station which has the same PI (Program Identification) code. When "REG OFF" appears on the display, the radio will select the RDS station which has the same three-digit number PII code.

- b. If the radio cannot find an RDS station for 40 seconds, the radio will mute all programs and begin seeking an RDS station of the same PI code by using the AF list. If the radio cannot seek out any station in one pass because the signals are too weak, the radio will begin seeking all the FM broadcasts again. A beep will sound and "SEARCH" will appear on the display to tell you when this feature starts operation.

If the signal gets extremely weak, the radio will stop seeking a station and "NOTHING" will appear on the display for 2 seconds.

- c. If a cassette is inserted in the slot with "NF" appearing on the display, the cassette can be played until an "FM" station is received.

- d. To cancel the NF mode, push the "NF" button twice. "NF" will then disappear from the display.
-

(e) Adjusting the tone

To adjust a low-pitch tone, push the "MODE" button repeatedly until "BASS 0" appears on the display, then push the level button (to either the left or right side) to suit your preference. The low-pitch tone level can be changed from "BASS -10" to "BASS +10" and the level will appear on the display.

To adjust a high-pitch tone, push the "MODE" button repeatedly until "TREB 0" appears on the display, then push the level button (to either the left or right side) to suit your preference. The high-pitch tone level can be changed from "TREB -10" to "TREB +10" and the level will appear on the display.

(f) Adjusting the sound balance

To balance the sound between the right and left speakers, push the "MODE" button repeatedly until "BAL 0" appears on the display, then push the level button (to either the left or the right side) to suit your preference. The sound balance of the left and right speakers can be changed from "BAL L14" to "BAL R14" and the sound balance will appear on the display.

To balance the sound between the front and rear speakers, push the "MODE" button repeatedly until "FAD 0" appears on the display, then push the level button (to either the left or right side) to suit your preference. The sound balance of the front and rear speakers can be changed from "FADE F14" to "FADE R14" and the sound balance will appear on the display.

(g) Listening to the cassette tape

1. Put the cassette into the slot, with the tape side to the right and lightly push it in. The tape player will grab the cassette and slide it into place to play it. If the radio is on when inserting the cassette, the radio will automatically turn off.

If the cassette is already in the slot, push the "TAPE" button.

1-7 AM/FM radio with electronic tuner and cassette tape player (type A)

At this time, "PLAY" will appear on the display.

The tape player can also be turned on by pushing the "PWR/VOL" knob if the tape player was playing when the system was turned off by pushing the knob.

When a metal or chrome equivalent tape is inserted, the player will automatically adapt to it and "MTL" will appear on the display.

2. If using a tape recorded with Dolby NR*, push the DOBLY NR button. The Dolby noise reduction system will operate. To play a tape recorded without Dobby NR*, push the button once again.
Dolby noise reduction manufactured under license from Dolby Laboratories Licensing Corporation "DOLBY" and the double D symbol are trademarks of Dolby Laboratories Licensing Corporation.
 3. Turn the "PWR/VOL" knob to adjust the volume.
 4. Select your program. (See [Selecting a program.](#))
 5. Adjust the tone and sound balance. (See [Adjusting the tone](#) and [Adjusting the sound balance.](#))
 6. To turn the player off, push the "PWR/VOL" knob.
 7. To eject the cassette, push the "EJECT" button. As this is done, the player will turn off. If the radio was on when the cassette tape was inserted, it will automatically turn on again.
The key can be at any position to eject the cassette.
-

(h) Selecting a program

1. Push the "PROG" button to select a side to play. The tape operation indicator display shows you which side is being played.
The player will automatically reverse directions at the end of the tape to play the other side.
 2. Push the "REW/FF (TUNE SEEK)" button on either side to fast forward or rewind the tape. At this time "FF" or "REW" will appear on the display. To stop either fast forwarding or rewinding, push the "TAPE" button. The tape will resume playing.
-

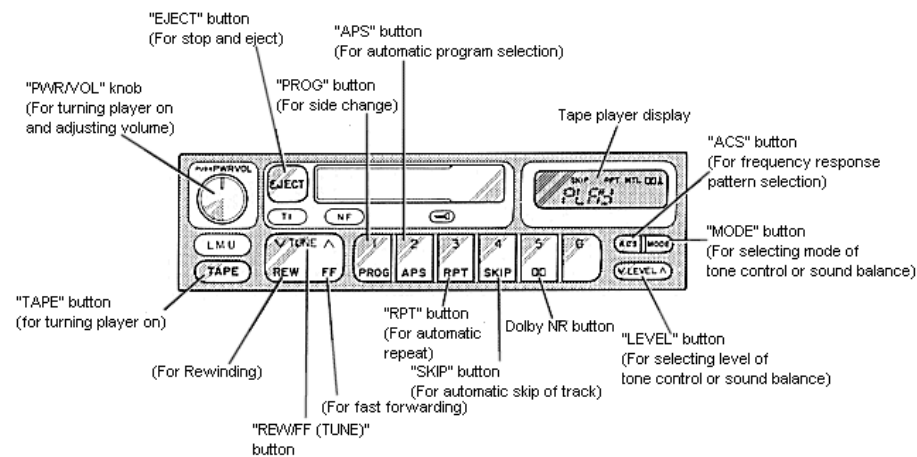
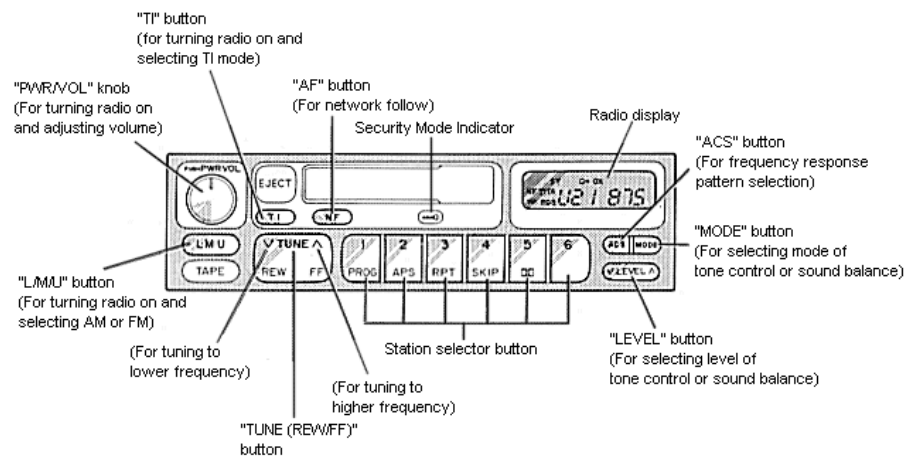
OPERATION OF INSTRUMENTS AND CONTROLS**AM/FM radio with electronic tuner and cassette tape player (type B)****(a) Listening to the radio**

1. Push the "L/M/U" button to turn the radio on and select either an AM or FM broadcast, or push the "TI" button to receive a TI (Traffic Information) station. (See [Receiving traffic information from the RDS \(Radio Data System\)](#).)

"L", "M", "U1" or "U2" will appear on the display.

The radio can also be turned on by pushing the "PWR/VOL" knob if the radio was on when the system was turned off.

2. Turn the "PWR/VOL" knob to adjust the volume.
3. Tune in the desired station. (See [Selecting a station](#) and [Presetting a station](#).)

The radio will charge automatically to stereo reception when an FM stereo broadcast is being received. At the same time, "ST" will appear on the display. When the receiving signal gets weak, the channel separation will automatically be reduced for the lowest noise. If the signal becomes extremely weak, the radio will switch over to monaural reception.

4. Adjust the tone and sound balance (See [Adjusting the tone](#) and [Adjusting the sound balance](#).)
5. To turn the radio off, push the "PWR/VOL" knob.

(b) Selecting a station

Tune in the desired station using one of the following methods. The frequency will appear on the display.

Preset tuning:

Use for tuning-in to a desired present station. (See [Presetting a station](#).)

1. Push the "L/M/U" button repeatedly until the desired selection appears on the display.
2. Push the station selector button which has been preset to the desired station. The radio will tune in to the station and the button number will appear on the display.

Seek tuning:

Use for automatic station search and stop.

Push the "TUNE SEEK (REW/FF)" button on either side and hold it until a beep is heard. The radio will begin seeking up or down for a station of the nearest frequency and will stop on reception. Each time you push the button, stations will be sought out one after another.

If the radio cannot seek out any stations in one pass because of too weak signals, the radio will begin seeking again with sensitivity boosted for searching out weak stations. At this time, "DX" will appear on the display.

Manual tuning:

Push the "TUNE SEEK (REW/FF)" button on either side within 0.5 second. Each time you push the button, the radio will step up or down to another frequency where stations could exist.

(c) Presetting a station

1. Push the "L/M/U" button repeatedly until the desired selection, "L", "M", "U1" or "U2" appears on the display.
You can preset any desired six stations in each selection. When you preset a station, check which selection you have used.

1-7 AM/FM radio with electronic tuner and cassette tape player (type B)

2. Tune in the desired station. (See [Selecting a station.](#))
3. Push one of the station selector buttons and hold it until a beep is heard. This sets the station to the button and the nutton number will appear on the display.

To change the preset station to a different one, follow the same procedure.

The preset station will be cancelled when the power source is severed (battery disconnected, burnt fuse, etc.)

(d) Receiving traffic information from the RDS (Radio Data System)

1. The radio will automatically switch to the RDS mode to receive an RDS station while tuned to FM broadcasts. At this time, "RDS" and the name of the RDS station will appear on the display. When you tune in a new FM station with RDS mode, the new frquency will appear on the display for 5 seconds before the name appears.
2. Tune in the desired station that broadcasts traffic information by using one of the following methods. When the radio receives a station which broadcasts traffic information, "TP" (Traffic Program) will also appear on the display. You can then listen to regular programs and to traffic information between the regular programs.

Preset turning, seek tuning and manual tuning:

Use for tuning-in to a desired station. (See [Selecting a station.](#))

TI (Traffic Information) tuning:

Use for receiving TI stations all over the band.

- a. The radio is switched to the TI mode by pushing the "TI" button. At this time, "TI" will appear on the display. If the radio does not receive a TI station for 20 seconds after the "TI" button is psuhed, the radio will begin seeking a TI station by using the AF (Alternative Frequencies) list from the TI station and will stop on receiving a TI station. A beep will sound and "SEARCH" will appear on the display to tell you when this feature starts operation. If the radio cannot find any station in one pass because the signals are too weak, the radio will begin seeking again with sensitivity boosted to search out weak stations. At this time, "DX" will appear on the display. If the signal gets extremely weak, the radio wil stop seeking a station and "NOTHING" will appear on the display for 2 seconds. After this, if the radio cannot receive a TI station for 20 seconds, the radio will begin seeking again. When "TI" appears on the display, the radio will receive a TI station only if seek tuning is used.
- b. If the selected station is broadcasting another program when traffic information is desired, push the "TI" button until "TA" (Traffic Announcement) appears. When "TA" appears on the display, the radio mutes all programs but the traffic program, or, if a cassette is inserted in the slot, the cassette will be played until traffic information begins. When the traffic information ends or the signal gets weak, the initial programming is resumed.
- c. To return to normal mode from the TI mode, push the "TI" button until "TI" and "TA" disappear from the display.

RDS auto tuning:

Use for seeking RDS stations all over the band.

- a. Push the "NF" (Network Follow) button for less than 2 seconds to receive the same program while tuning in an RDS station. At this time, "NF" will appear on the display. When reception conditions worsen, a network which broadcasts the same program will be selected using the AF list from the RDS station. To change the NF mode, push the "NF" button for at least 2 seconds. When "REG ON" appears on the display, the radio will select the RDS station which has the same PI (Program Identification) code. When "REG OFF" appears on the display, the radio will select the RDS station which has the same three-digit number PII code.
 - b. If the radio cannot find an RDS station for 40 seconds, the radio will mute all programs and begin seeking an RDS station of the same PI code by using the AF list. If the radio cannot seek out any station in one pass because the signals are too weak, the radio will begin seeking all the FM broadcasts again. A beep will sound and "SEARCH" will appear on the display to tell you when this feature starts operation. If the dignal gets extremely weak, the radio will stop seeking a station and "NOTHING" will appear on the display for 2 seconds.
 - c. If a cassette is inserted in the slot with "NF" appearing on the display, the cassette can be played until an "FM" stationis received.
 - d. To cancel the NF mode, push the "NF" button twice. "NF" will then disappear from the display.
-

(e) Adjusting the tone

Automatic tone adjustment

Push the "ACS" button repeatedly until the desired frequency response pattern appears on the display. This function automatically controls the tone in accordance with the selected pattern. To cancel it, push the button until "DEFEAT" appears on the display. This allows you to adjust the tone manually.

Manual tone adjustment

Before using the tone controls, push the "ACS" button repeatedly until "DEFEAT" appears on the display.

To adjust a low-pitch tone, push the "MODE" button repeatedly until "BASS 0" appears on the display, then push the level button (to either the left or right side) to suit your preference. The low-pitch tone level canbe changed from "BASS -10" to "BASS +10" and the level will appear on the display.

To adjust a high-pitch tone, push the "MODE" button repeatedly until "TREB 0" appears on the display, then push the level buton (to either the left or right side) to suit your preference. The high-pitch tone level can be changed from "TREB -10" to "TREB +10" and the level will appear on the display.

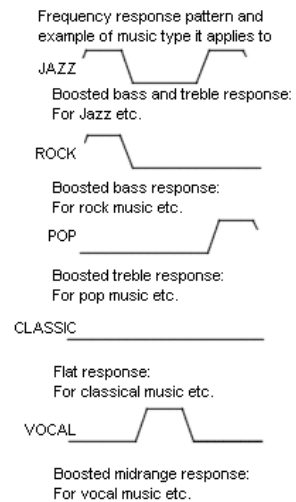

(f) Adjusting the sound balance

To balance the sound between the right and left speakers, push the "MODE" button repeatedly until "BAL 0" appears on the display, then push the level button (to either the left or the right side) to suit your preference. The sound balance of the left and right speakers can be changed from "BAL L10" to "BAL R10" and the sound balance will appear on the display.

To balance the sound between the front and rear speakers, push the "MODE" button repeatedly until "FAD 0" appears on the display, then push the level button (to either the left or right side) to suit your preference. The sound balance of the front and rear speakers can be changed from "FADE F10" to "FADE R10" and the sound balance will appear on the display.

(g) Listening to the cassette tape

1. Put the cassette into the slot, with the tape side to the right and lightly push it in. The tape player will grab the cassette and slide it into place to play it. If the radio is on when inserting the cassette, the radio will automatically turn off. If the cassette is already in the slot, push the "TAPE" button. At this time, "PLAY" will appear on the display. The tape player can also be turned on by pushing the "PWR/VOL" knob if the tape player was playing when the system was turned off by pushing the knob. When a metal or chrome equivalent tape is inserted, the player will automatically adapt to it and "MTL" will appear on the display.
 2. If using a tape recorded with Dolby NR*, push the DOBLY NR button. The Dolby noise reduction system will operate. To play a tape recorded without Dobby NR*, push the button once again. Dolby noise reduction manufactured under license from Dolby Laboratories Licensing Corporation "DOLBY" and the double D symbol are trademarks of Dolby Laboratories Licensing Corporation.
 3. Turn the "PWR/VOL" knob to adjust the volume.
 4. Select your program. (See [Selecting a program.](#))
 5. Adjust the tone and sound balance. (See [Adjusting the tone](#) and [Adjusting the sound balance.](#))
 6. If desired, other functions may be used for your convenience. (See [Other tape player functions.](#))
 7. To turn the player off, push the "PWR/VOL" knob.
 8. To eject the cassette, push the "EJECT" button. As this is done, the player will turn off. If the radio was on when the cassette tape was inserted, it will automatically turn on again. The key can be at any position to eject the cassette.
-

(h) Selecting a program

1. Push the "PROG" button to select a side to play. The tape operation indicator display shows you which side is being played. The player will automatically reverse directions at the end of the tape to play the other side.
2. Push the "REW/FF (TUNE SEEK)" button on either side to fast forward or rewind the tape. At this time "FF" or "REW" will appear on the display. To stop either fast forwarding or rewinding, push the "TAPE" button. The tape will resume playing.

Manual program selection

Push the "REW/FF (TUNE)" button on either side to fast forward or rewind the tape. At this time, "FF" or "REW" will appear on the display. To stop either fast forwarding or rewinding, push the "TAP" button. The tape will resume playing.

Automatic program selection:

Use for quick access to a desired program.

1. Push the "APS" button. "APS" and program number "1" will appear on the display.
2. Repeat the push until the number indicates how many programs ahead of/behind the one currently being played you wish to listen to (include the program you are currently listening to when counting back previous programs). The maximum number of settings is nine.

The tenth push on the button will cancel the function and "APS" will go off.

3. Push the "REW/FF (TUNE)" button to get the tape going in the direction of the program. At this time "FF" or "REW" will also appear on the display. The player will automatically stop at the beginning of the selected program and play it.

If the number you set exceeds the number of the programs remaining on the side currently being played, the tape will fast forward to the beginning of the other side (when fast forwarding) or rewind to the beginning of that side (when rewinding).

This function does not work properly unless the blank portions on the tape have 3 seconds or more between one program and another.

(i) Other tape player functions.

"RPT" button:

Use for automatic repeat of the program currently being listened to.

Push the "RPT" button while the program is being played. As this is done, "RPT" will appear on the display. When the program is finished, the tape will automatically be rewound to the beginning of the program and the program will be played again. To cancel it, press the button once again.

This function does not work properly unless the blank portions on the tape have 3 seconds or more between one program and another.

"SKIP" button:

Use for automatic skip of blank portions between programs.

Push the "SKIP" button. "SKIP" appears in the display. The player will automatically skip any blank portions of 15 seconds or more, and play the next program, even if it is on the other side. To cancel it, push the button once again.

(j) Anti-theft system.

To deter theft of your radio unit, the system is designed so that the radio unit becomes inoperable if the unit is stolen from the vehicle.

Setting the anti-theft system

The system is not preset at the factory. You must input a three-digit identification number decided by you.

"SECURITY"

1. Make sure the radio unit is turned off with the ignition switch in "ACC".
2. While holding the "1 (PROG)" and "6" buttons in, push and hold the PWR/VOL knob until "SECURITY" appears on the display.

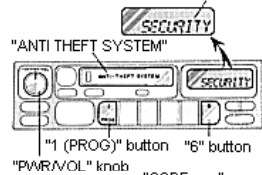

3. Press the "1 (PROG)" button while holding the "TUNE (REW/FF)" button in. "CODE ---" will appear on the display.

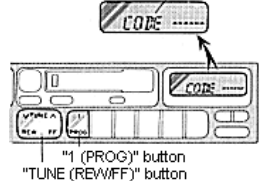

4. Input your identification number by pressing the "1 (PROG)", "2 (APS)", "3 (RPT)" buttons repeatedly. Use the "1 (PROG)" button for the first digit, the "2 (APS)" button for the second digit and "3 (RPT)" button for the last digit. For example, if your number is 210, press the "1 (PROG)" button three times, the "2 (APS)" button twice and the "3 (RPT)" button once. If the display returns to "CODE ---" while inputting, try again.

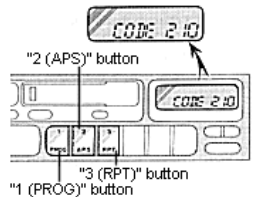

We recommend that your identification number be associated with something easy to remember. In case you are unsure of the number, write it in a notebook you normally carry. Do not leave it behind in your vehicle.

1-7 AM/FM radio with electronic tuner and cassette tape player (type B)

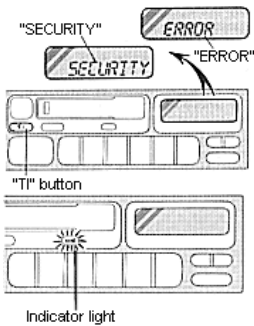

5. With your identification number appearing on the display, press the "TI" button and hold it in until "SECURITY" appears on the display. "SECURITY" will go off to indicate the system is set. If invalid buttons have been used, "ERROR" will appear on the display before "SECURITY" appears. Try again from step 3.

- With your identification number One the system is set, the indicator light turns on and off with the ignition switch in "OFF" and "SECURITY" will appear each time the key is turned to the "ACC" position. To change the identification number for some reason, cancel the system (See [Cancelling the anti-theft system.](#)) and set it again with a new number.

The system will be activated if the electrical power source is disconnected from the radio unit. When the system is activated, the audio system cannot be turned on even after the power supply resumes and "SECURITY" will appear on the display. If this happens, such as when the battery is discharged, see [If the anti-theft system is activated.](#)

Cancelling the anti-theft system

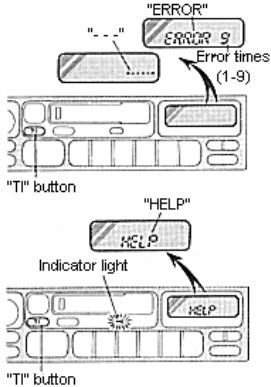

1. Follow the steps 1 to 4 described in [Setting the anti-theft system.](#)
2. With your identification number appearing on the display, press the "TI" button and hold it in until "- -" appears on the display. "- -" will go off to indicate the system is cancelled. If invalid buttons have been used, "ERROR" will appear on the display and "SECURITY" appears. Try again from step 3 in [Setting the anti-theft system.](#)
The figure with "ERROR" indicates how many errors you have made. You may make up to nine errors, but no more!

NOTICE:

A tenth error will activate the anti-theft system and "HELP" will appear on the display. The audio system will be completely inoperable. At this time, the indicator light also comes on. If this occurs, contact your Toyota dealer.

At the time or resale of your vehicle, cancel the system for the new owner.

If the anti-theft system is activated

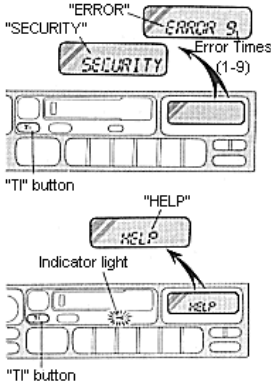

The audio system make inoperable by the activated anti-theft system will be operable if you give it the correct identification number.

1. Follow the steps 3 and 4 described in [Setting the anti-theft system.](#)
2. With your identification number appearing on the display, press the "TI" button and hold it in until "SECURITY" appears on the display. "SECURITY" will go off to indicate that the system is reset, and the audio system is operable. If invalid buttons have been used, "ERROR" will appear on the display before "SECURITY" appears. Try again from the beginning.

See [Cancelling the anti-theft system](#) for notes on the figure with "ERROR".

OPERATION OF INSTRUMENTS AND CONTROLS



Instrument Panel Overview (LHD)

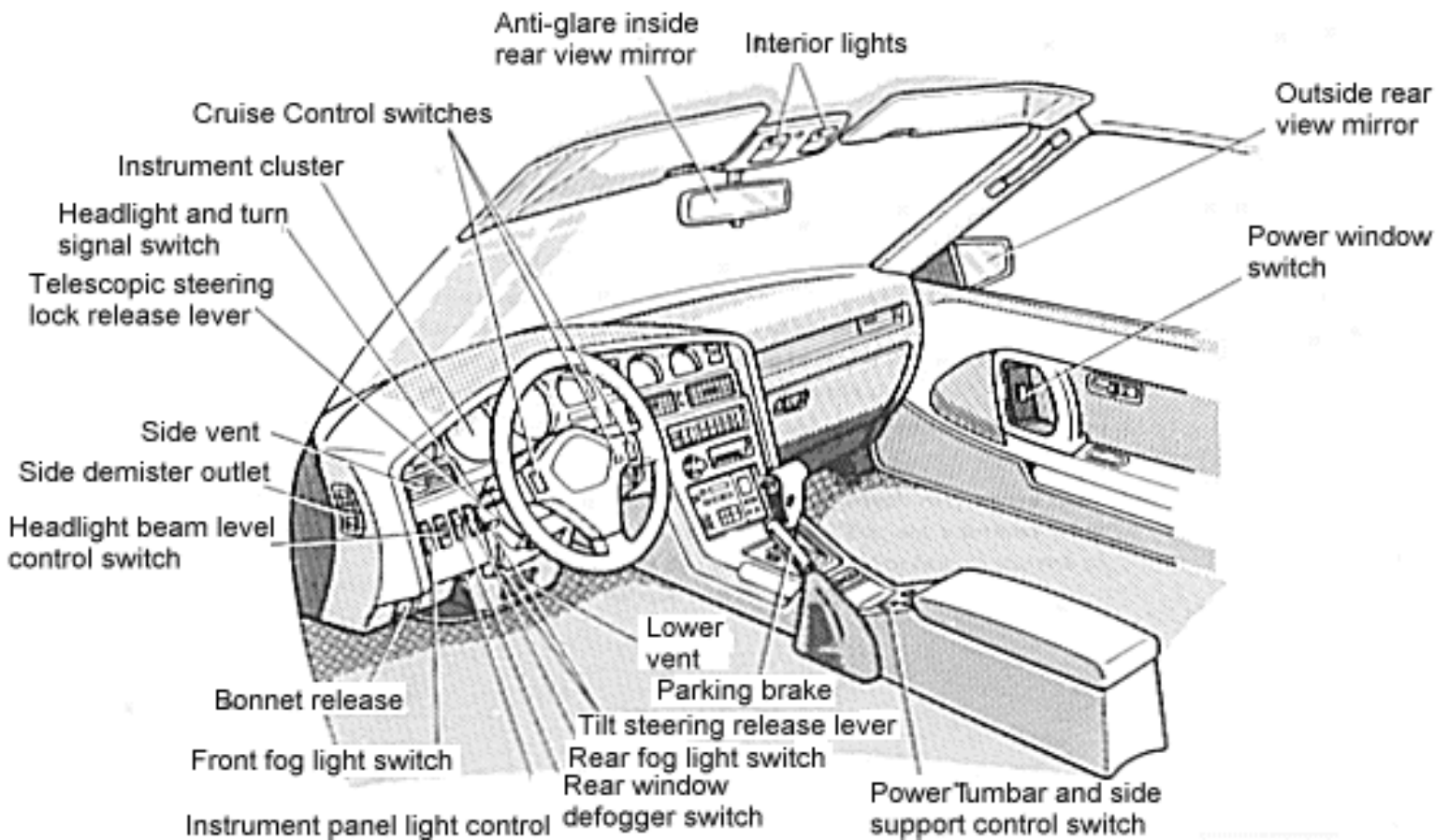

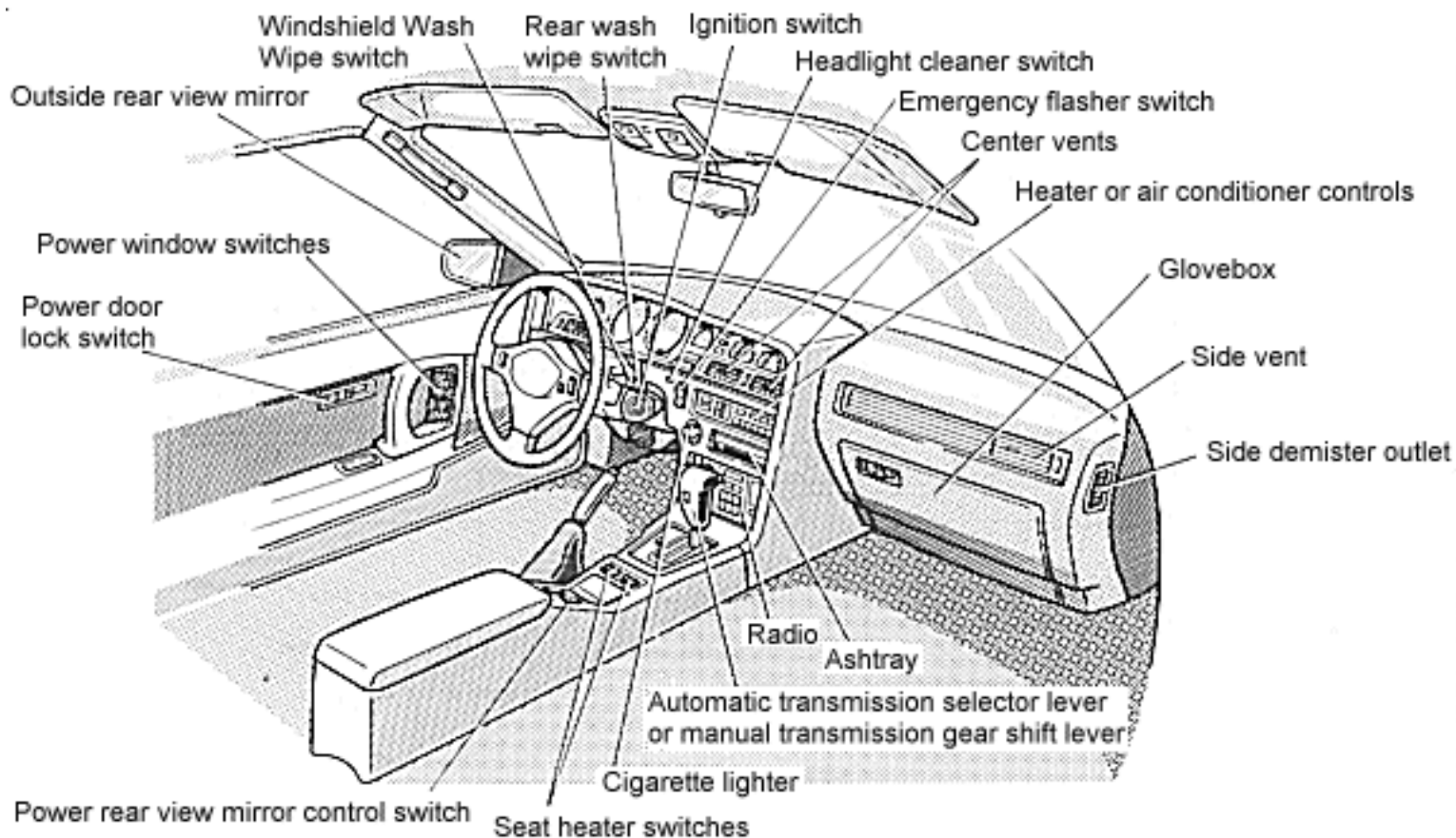

OPERATION OF INSTRUMENTS AND CONTROLS



Instrument Cluster Overview (LHD)

