



SureRide™ / Titan Child Restraint System

Owner's Manual

Keep for future use.

Rear-facing

2.3 - 18 kg
(5 - 40 lbs)

48 - 102 cm
(19 - 40 in.)

Forward-facing

10 - 29.4 kg
(22 - 65 lbs)

71 - 137 cm
(28 - 54 in.)

Para instrucciones en Español,
llamar al: 1-800-233-5921

WARNING:

To reduce the risk of serious injury
or death, read this owner's manual prior
to installing and using this child restraint.

More children are killed every year as passengers in car crashes than by any other type of injury.

To reduce the risk of **SERIOUS INJURY** or **DEATH**, read this owner's manual and your vehicle owner's manual before installing and using this child restraint. Using a child restraint makes a big difference. By properly using this child restraint and following these instructions (and the instructions that accompany your vehicle), you will greatly reduce the risk of serious injury or death to your child from a crash. Do not be misled by the commonly used term "safety seat;" no restraint system can prevent all injuries in all crashes. Many properly restrained adults and children are injured in motor vehicle crashes, including relatively minor crashes. A properly used child restraint is the best way to minimize injuries to your child and to increase the chances for your child's survival in most crashes.

Table of Contents

Premature Infant Use	2
Warnings	3
Safe Practices	7
Recall Information for U.S. Customers.....	8
Public Notice for Canadian Customers.....	8
Motor Vehicle/Aircraft Usage	9
LATCH Information	9
Symbol Legend.....	9
Care and Cleaning	10
Storing Your Instructions.....	10
Visual Glossary	12
Using the SureRide™ Rear-facing	14
Using the SureRide Forward-facing	16
Installation	
Rear-facing Using a Seat Belt	18
Rear-facing Using the LATCH System	21
Forward-facing Using a Seat Belt.....	25
Installing Tether Strap	27
Forward-facing Using the LATCH System	28
Positioning the Harness Strap	32
Adjusting the Recline Stand	34
Using the Locking Clip.....	36
Securing Your Child	38
Adjusting the Crotch Strap	39
Adjusting the Harness Strap	40
Removing Your Child from the Restraint	41
Removing the Tether Strap	41
Removing the LATCH System.....	42
Installing the Accessories.....	44
Replacement Parts	46
Limited Warranty	47

U.S. REGULATORY NOTICE

This child restraint meets all applicable requirements of Federal Motor Vehicle Safety Standard 213.

For Canadian Models

CANADIAN REGULATORY NOTICE

This child restraint meets all applicable requirements of Canadian Motor Vehicle Safety Standards CMVSS 213 and 213.1.

Child Requirements

- **No restraint can guarantee absolute protection from injury in every crash.**
- **This child restraint is designed for use by children in rear-facing and forward-facing positions.** To use this child restraint properly, children **MUST** meet weight/size specifications as follows:

For Rear-facing Use

- 2.3 to 18 kg (5 to 40 lbs)
- 48 to 102 cm (19 to 40 inches)
- **Top of head is at least 25 mm (1 inch) below the top of the child restraint seat back.**

*The American Academy of Pediatrics recommends that children ride in the **rear-facing** position to the highest weight or height allowed by the child restraint.*

Note: Once your child **exceeds 18 kg (40 lbs) OR** the top of their head is **within 25 mm (1 inch)** of the top of the child restraint seat back, you **MUST** use this child restraint in the **forward-facing position.**

For Forward-facing Use

- 10 to 29.4 kg (22 to 65 lbs)
- 71 to 137 cm (28 to 54 inches)
- At least one year of age

Note: Once your child **exceeds 29.4 kg (65 lbs) OR** is **taller than 137 cm (54 inches)**, they can no longer safely use this child restraint, and you should consider using a booster seat.

PREMATURE INFANT USE

Before using this child restraint for preterm or low birth weight infants you must read and follow the guidelines in this section.

According to the U.S. National Highway Traffic Safety Administration, a properly installed child restraint reduces the risk of death by over 70 percent for infants involved in crashes. Federal Motor Vehicle Safety Standard (FMVSS) 213 establishes design and dynamic performance requirements for child restraint systems. However, the standard has no minimum weight limit and does not address the special medical needs of preterm or low-birth weight infants. To ensure that preterm and low-birth weight infants are transported safely, the guidelines published by the American Academy of Pediatrics (AAP) in Pediatrics 2009;123:1424–1429 must be followed.

All children should ride rear-facing in the vehicle as long as possible. Preterm and low-birth weight infants are at additional risk of breathing difficulties and heart problems when placed in a child restraint. Evenflo requires that the evaluation recommended by the AAP be conducted for all infants born earlier than 37 weeks and all newborn infants who weigh less than 5 pounds at birth before their first car trip to check for breathing difficulties or heart rate problems when traveling in a rear-facing child restraint.

The AAP recommends that appropriate hospital staff observe your infant in the child restraint for a period of 90 to 120 minutes or the duration of travel, whichever is longer. This period of observation must be performed with the infant properly positioned as described in these instructions and with the child restraint placed at an angle that is approved for use in the vehicle. The hospital staff will check for any breathing difficulties or heart rate problems. Your child's pediatrician will let you know if there are any special considerations for travel. The number of trips and the duration of time the infant is seated in the child restraint should be minimized. A caregiver should ride in the back seat to monitor the infant during travel.

You can learn more about the AAP's recommendations for observation of newborns and the guidelines for safe transportation of preterm and low-birth weight infants, as well as other resources for parents and medical professionals, at <http://www.aap.org/healthtopics/carseatsafety.cfm>.

! WARNING

Air Bag Warnings

- **DO NOT** use this restraint in the front seat of a vehicle equipped with an air bag. Interaction between a rear-facing restraint and air bags may cause serious injury or death. Air bags may cause serious injury or death to children 12 and under. If your vehicle has an air bag, refer to your vehicle owner's manual for child restraint installation.
- If the rear seat of your vehicle is equipped with side air bags, refer to the following information for proper usage:
Vehicles built prior to the 2002 model year: **DO NOT** use this restraint in a vehicle seating position equipped with a side air bag unless authorized by the vehicle manufacturer.
Model year 2002 and newer vehicles: Refer to your vehicle owner's manual before placing this restraint in a seating position equipped with a side air bag.
- **DO NOT** place any objects between the restraint and the side air bag, as an expanding air bag may cause the items to strike your child.

! WARNING



DO NOT place rear-facing child seat on front seat with air bag. **DEATH or SERIOUS INJURY** can occur. The back seat is the safest place for children 12 and under.

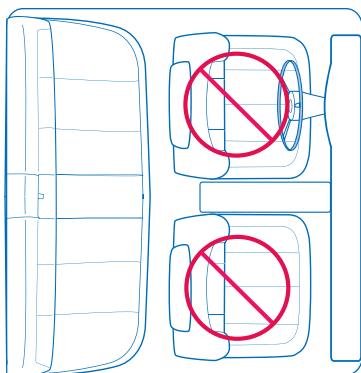

WARNING

Location Warnings

- According to statistics, children are safer when properly restrained in a rear seating position than in the front seating position. Generally, the center rear position is safest and should be used if available.
- **ONLY** use this child restraint on forward-facing vehicle seats. **DO NOT** use this restraint with vehicle seats that face the rear or side.
- **ONLY** use this child restraint on vehicle seats with backs that lock into place.
- Some child restraints do not fit all vehicles or all seating locations. There are many thousands of combinations of vehicle makes, models, child restraint configurations, seat belt designs, and seat cushion shapes. The easiest way to determine whether your child restraint is suitable for a particular seating position is to check for a tight installation. If the child restraint cannot be properly installed, **DO NOT** use the child restraint. Consult vehicle owner's manual, try a different seating location, or call Evenflo at **1-800-233-5921 (U.S.) or 1-937-773-3971 (Canada)**.

Premature Infants

- **DO NOT** use this or any child restraint with a premature infant until after consulting your doctor. Premature infants may have difficulty breathing when in a sitting position.



Rear-facing Warnings

- **DO NOT** use this child restraint rear-facing in a vehicle equipped with lap belts that only lock during a sudden stop or crash (emergency locking retractors). You must use a seating location with a locking seat belt. Check your vehicle owner's manual to see if you have emergency locking retractors.
- When using this restraint rear-facing, **DO NOT** loosen the vehicle seat belt to provide more leg room as this will prevent the child restraint from protecting your child.
- **DO NOT** use the top two sets of harness slots rear-facing. The harness may not properly restrain the child during a crash.
- The headrest on the vehicle seat that the child faces should be placed in the lowest position. The vehicle seat back must be fully padded and free of any hard objects.
- Fold-down armrests could pose a hazard to a rear-facing child in certain types of collisions. Consult your vehicle owner's manual before installing any rear-facing child restraint in front of a fold-down armrest.

WARNING

- **NEVER** turn a child restraint forward-facing with an infant who weighs less than 10 kg (22 lbs) or who is less than one year of age. Crash forces may cause serious neck injury or death.



Forward-facing Warnings

- If your child weighs more than 29.4 kg (65 lbs) or his/her shoulders are above the highest harness level, you **MUST** discontinue using this child restraint, as it may no longer adequately protect your child.
- **DO NOT** use the three sets of lower harness slots forward-facing. The harness may not properly restrain the child during a crash.

Seat Belt Warnings

- **DO NOT** use this child restraint in a vehicle with door-mounted seat belts.
- **DO NOT** use this child restraint in a vehicle with seat belts that automatically move along the vehicle frame when the door is opened. These seat belts will not hold a child restraint properly.
- Use only with vehicle seat belts that can be pulled tight and will stay locked.
- **DO NOT** use this child restraint if it moves more than 25 mm (1 inch) forward or side-to-side at the belt path. Serious injury or death may result from poor installation. Move the child restraint to another seating location.
- **DO NOT** allow the seat belt release button to touch the child restraint. Accidental contact may cause the seat belt to release. If necessary, turn the seat belt release button away from the child restraint or move the child restraint to a different location.
- Failure to adjust the harness or seat belts snugly around your child may result in your child striking the vehicle's interior during a sudden stop or crash. Serious injury or death may occur.
- If the vehicle seat belts are not routed and fastened correctly, the child restraint may not protect your child in a crash.
- Remove locking clip from vehicle seat belt when not used with a child restraint, or the vehicle seat belt will not properly restrain an adult or child. Serious injury could occur.



LATCH (Lower Universal Anchorage System [UAS] or Isofix) Warnings

- **ONLY** use for securing child restraint to lower LATCH anchor points.
- **ALWAYS** read and follow exactly the instructions that

WARNING

LATCH (Lower Universal Anchorage System [UAS] or Isofix) Warnings – cont.

accompany your vehicle and child restraint.

- **NEVER** attach two hooks to one vehicle lower anchor point.
- **DO NOT** use the vehicle seat belts to install a child restraint when using the LATCH system.
- **ONLY** use the LATCH system as described in these instructions. Serious injury or death may result from misuse.
- **ALWAYS** be sure that the LATCH hook is fully engaged onto the LATCH anchor point by pulling hard on the LATCH harness. If it is not totally engaged, the LATCH system will not secure your child restraint. Serious injury or death may result.
- **DO NOT** use this child restraint if it moves more than 25 mm (1 inch) forward or side-to-side at the belt path. Serious injury or death may result from poor installation. Try again or use the vehicle belts to install the child restraint.
- To avoid a strangulation hazard, you **MUST** store the unused LATCH harness, with all slack removed, in the storage area on the back of the seat. Roll or fold the excess LATCH strap and secure with a rubber band to prevent serious injury to vehicle occupants.
- In addition to these instructions, read and follow your vehicle owner's manual regarding installation of child restraints and LATCH. If there is a discrepancy, follow your vehicle owner's manual.



Top Tether Warnings

- Failure to secure the top tether strap (provided) as specified in these instructions could result in serious injury.
- The top tether strap **MUST** be used if your vehicle has a plain lap belt that only locks during a sudden stop or crash (emergency locking retractors) AND/OR if your vehicle has seat belts whose buckles extend from a slot in the vehicle seat cushion in front of the crease where the seat and back cushions meet. Otherwise, the child restraint cannot be installed tightly, increasing the risk of injury to your child. Check your vehicle owner's manual to see if your vehicle has emergency locking retractors.
- To avoid a strangulation hazard, you **MUST** tightly roll or fold excess tether strap and secure with the strap/rubber band. Attach the tether hook to the storage clip when not in use. This will keep an unused tether from hitting someone during a crash.

WARNING

Additional Warnings

- **DO NOT** use child restraint if it is damaged, broken, or missing parts.
- **DO NOT** use this restraint if it has been involved in a crash. It must be replaced.
- **NEVER** leave child unattended.
- In hot or sunny weather, **ALWAYS** check the seat, the buckle and LATCH hooks, and adjuster for hot areas before placing a child into the child restraint. Your child could be burned. Cover the child restraint with a light colored blanket when you leave the vehicle.
- This child restraint must be securely belted to the vehicle at all times. An unsecured child restraint may injure someone if a crash occurs.
- **DO NOT** attach additional padding, toys, or other devices not made by Evenflo to the child restraint. Items not tested with the child restraint could injure the child.
- Failure to follow installation instructions could result in serious injury or death. These instructions and the instructions in your vehicle owner's manual must be followed carefully. If there is a conflict between the two, the vehicle owner's manual regarding child restraint installation must be followed.
- In cold weather, **DO NOT** dress the child in bulky clothing like snowsuits if the child is riding in a child restraint. Bulky coats/snowsuits make it difficult to properly tighten the harness to the child, which may allow the child to be ejected from the restraint during a crash.

Safe Practices

- **Everyone rides buckled up or the vehicle does not go.** Make no exceptions for adults or children. If someone unbuckles, stop the vehicle. Being firm and consistent from the start will mean fewer discipline problems as children get older. An unrestrained person can be thrown into and injure other passengers.
- Many safety advocates and healthcare professionals recommend that children ride rear-facing for as long as possible. See limitations recommended on rear-facing use on page one.
- **NEVER** try to tend to a crying baby's needs while driving. **NEVER** take a baby out of a child restraint for comforting while the vehicle is moving.
- **DO NOT** allow a child in a vehicle to have objects such as lollipops or ice cream on a stick. The object can injure the child if the vehicle swerves or hits a bump.

- **DO NOT** feed an infant who is riding in a child restraint.
- Put sharp or heavy items in the trunk. Anything loose can be deadly in a crash.
- Dress the child in clothing with legs. Since the harness must pass between the child's legs, clothing with legs permits a tighter fit.
- In hot, sunny weather, cover the seat and buckle with a light colored blanket when you leave the vehicle.
- For child restraints equipped with leather seat pads, cover your seat with a blanket in warm weather. Leather can become very hot in direct sunlight.
- In cold weather, a child may need an extra blanket for warmth. Secure the child in the child restraint and cover both the child and the restraint with a blanket.

Recall Information for U.S. Customers

- Child restraints could be recalled for safety reasons. You must register this restraint to be reached in a recall. Send your name, address, and the restraint's model number and manufacturing date to **Evenflo Company, Inc., 1801 Commerce Dr., Piqua, OH 45356** or call 1-800-233-5921. You may also register online at:
www.evenflo.com/registercarseat.
- For recall information, call the U.S. Government's Vehicle Safety Hotline at 1-888-327-4236 (TTY:1-800-424-9153) or go to: **<http://www.NHTSA.gov>**.

Public Notice for Canadian Customers

- Child restraints could be recalled for safety reasons. You must register this restraint to be reached in a recall. Send your name, address, and the restraint's model number and manufacturing date to **Evenflo Company, Inc., 1801 Commerce Dr., Piqua, OH 45356**, call 1-937-773-3971, or register online at:
www.evenflo.com/registercarseatcanada.
- For public notice information, call Transport Canada at 1-800-333-0510 (1-613-993-9851 in Ottawa region).

Motor Vehicle/Aircraft Usage

When used with the internal harness and properly installed pursuant to these instructions, this restraint is certified for use only in passenger and multi-purpose passenger motor vehicles, buses, and trucks equipped with Type I or II seat belts and in aircraft.

Airplane installation is the same as Type I vehicle installation. Turn the top of the airplane seat belt buckle away from the restraint for easy release and removal.



LATCH Information

“LATCH” (**L**ower **A**nchors and **T**ethers for **C**hildren) is a system for attaching the child restraint to your vehicle seat. It can be used in place of the seat belts in vehicles with **LATCH** anchors. Refer to your vehicle owner’s manual for the locations of **LATCH** anchors.

Note: Your vehicle owner’s manual may refer to this system as “Universal Anchorage System” or “ISOFIX.”

Symbol Legend



Air Bag Symbol – Alerts you to important information about air bag safety.



LATCH Symbol – Alerts you to important information about LATCH safety.



Tether Anchor Symbol – Alerts you to important information about tether anchor safety.

Care and Cleaning

- To help protect the vehicle upholstery, place a towel beneath and behind the child restraint.
- Plastic and metal parts may be wiped clean with mild soap and water and dried with a soft cloth. Do not use abrasive cleaners or solvents.
- Take care not to damage any labels.
- The harness can be wiped clean with mild soap and water. Allow harness to air dry. **DO NOT** immerse buckle in water or lubricate buckle.
- Machine wash the seat pad separately in cold water, delicate cycle, and tumble dry 10 to 15 minutes on low heat.
- **NEVER** use child restraint without the seat pad.
- Leather pads (not available on all models) may be cleaned. For best results spot clean with mild soap and water or with a mixture of 10 parts water to 1 part mild alcohol. Allow to air dry. **DO NOT MACHINE WASH.**

Storing Your Instructions

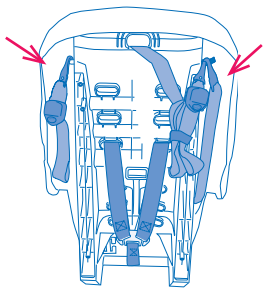

After thoroughly reading and following these instructions, **store the instructions in the clips on the sides of your child restraint.**

For future reference, record the **model number** of your child restraint **AND** the **date of manufacture** below.

Model Number: _____

Date of Manufacture: _____

This page is intentionally blank.

Visual Glossary

Your vehicle components may be significantly different than pictured. Consult your owner's manual to help you identify your vehicle components.

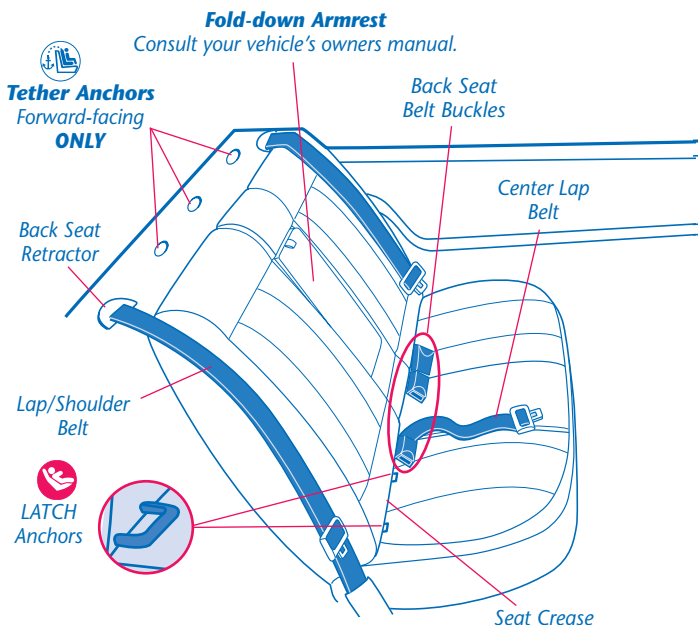

IMPORTANT: If your vehicle has **side air bags**, please refer to the warnings on page 3.

Front View

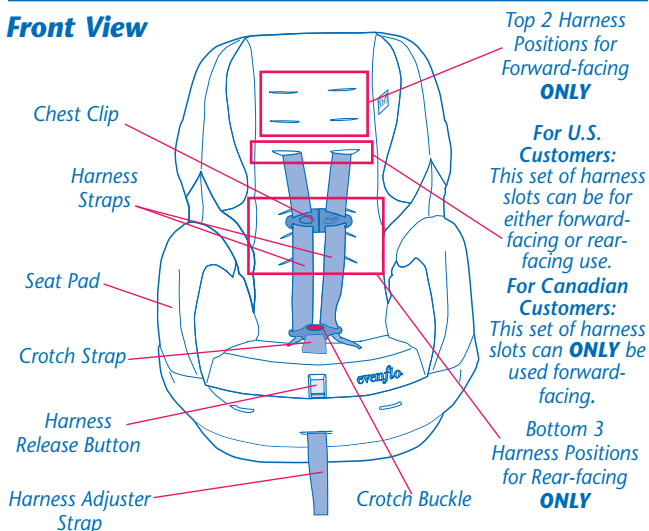

Front Seat Lap and Shoulder Belts

Headrests

Must be in the lowest position where the child restraint is located.

⚠ WARNING	
	DO NOT place rear-facing child seat on front seat with air bag. DEATH or SERIOUS INJURY can occur. The back seat is the safest place for children 12 and under.

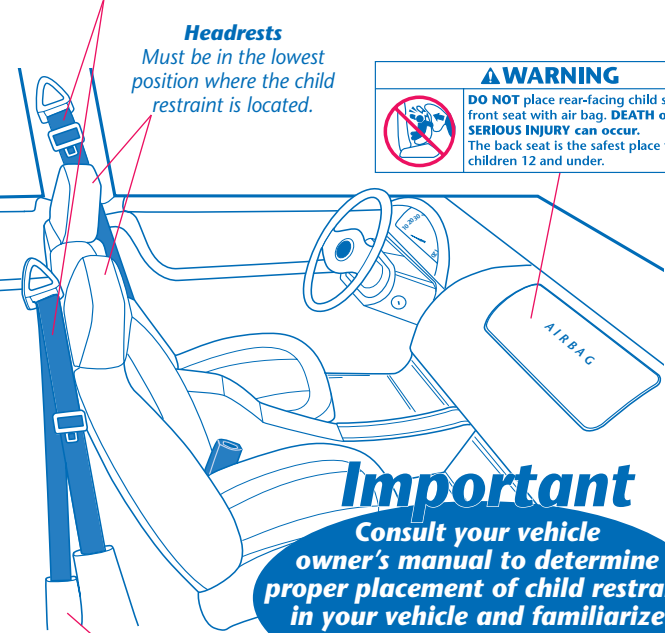

Front Seat Retractor

Important

Consult your vehicle owner's manual to determine proper placement of child restraint in your vehicle and familiarize yourself with your vehicle's components.

Back View

Tether Strap and Hook

Instruction Storage Area

LATCH Hook

Harness Straps

Locking Clip

Note: Recline Stand is nested below child restraint.

LATCH Hook

Top 2 Harness Positions for Forward-facing **ONLY**

For U.S. Customers: This set of harness slots can be for either forward-facing or rear-facing use.
For Canadian Customers: This set of harness slots can **ONLY** be used forward-facing.

Bottom 3 Harness Positions for Rear-facing **ONLY**

Splitter Plate

Using the SureRide Rear-facing

Child Requirements:

- **Weight:** 2.3 to 18 kg (5 to 40 lbs)
- **Height:** 48 to 102 cm (19 to 40 inches) **AND** the top of child's head is at least 25 mm (1 inch) below top of the child restraint seat back.

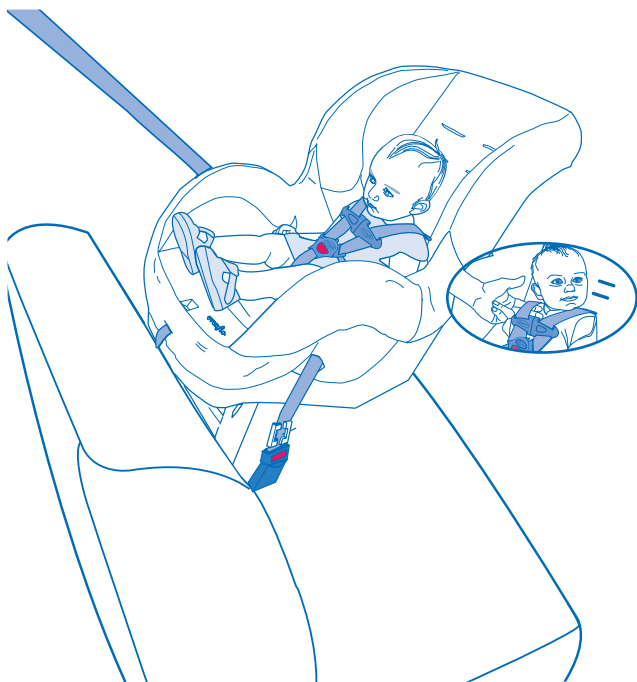

Note: Once your child exceeds 18 kg (40 lbs) **OR** the top of their head is within 25 mm (1 inch) of the top of the child restraint seat back, you **MUST** use this child restraint in the **forward-facing position**.

WARNING

When using this restraint rear-facing, **DO NOT** loosen the vehicle seat belt to provide more leg room, as this will prevent the child restraint from protecting your child.

1. Secure child restraint to the vehicle seat.

- Recline stand is flipped to the *recline* position (page 34).
- Install with vehicle seat belt (page 18) **or** LATCH system (page 21).
- Towel rolled up and placed beneath the Recline Stand, if necessary (page 36).
- Install locking clip, if necessary (page 36).

2. Set the child in the child restraint.

Top of head is at least 25 mm (1 inch) below the top of the child restraint seat back (page 1).

3. Fasten the buckle. Refer to page 38.

4. Make necessary adjustments.

- Crotch strap is snug against the child (page 39).
- Harness straps **MUST** be on the child's shoulders and snug, with no more than two-fingers width of space between the child and the harness strap (page 38).

5. Position and connect chest clip.

Chest clip/harness tie **MUST** be at armpit level (page 38).

6. Check your work.

- Recline stand is flipped to the *recline* position (page 34).
- The child restraint **DOES NOT** move more than 25 mm (1 inch) forward or side-to-side (pages 20 and 24).
- The child's back and bottom are flat against the back and bottom surfaces of the child restraint (page 38).
- Shoulder harness straps **MUST** start at or below shoulder height using the strap slots closest to your child's shoulders (page 32).
- Buckle tongues are fully engaged (page 38).
- The level arrow is level with the ground (page 18).

Using the SureRide Forward-facing

Child Requirements:

- **Weight:** 10 to 29.4 kg (22 to 65 lbs)
- **Height:** 71 to 137 cm (28 to 54 inches) **AND** the tops of the child's ears are at or below the child restraint seat back.
- **Age:** At least one year of age

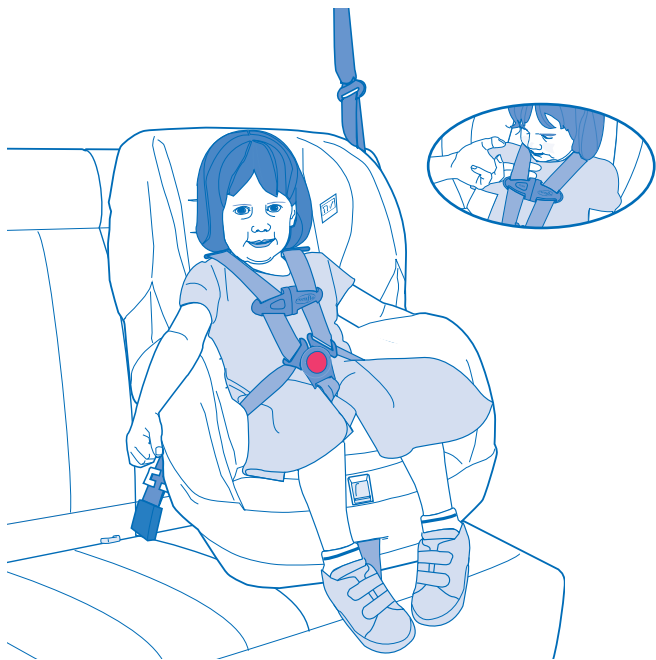

Note: Once your child exceeds 29.4 kg (65 lbs) **OR** is taller than 137 cm (54 inches), they can no longer safely use this child restraint, and you should consider using a booster seat.

WARNING

If your child weighs more than 29.4 kg (65 lbs) or their shoulders are above the highest harness level, you **MUST** discontinue use, or the child restraint will not protect your child.

1. Secure child restraint to the vehicle seat.

- Recline stand is flipped to the *upright* position (page 34).
- Install with vehicle seat belt (page 25) **or** LATCH system (page 28).
- Canadian consumers: Install tether strap (pages 27 and 31).
- Install locking clip, if necessary (page 36).

2. Set the child in the child restraint.

Tops of the child's ears are at or below the child restraint seat back (page 1).

3. Fasten the buckle. Refer to page 38.

4. Make necessary adjustments.

- Crotch strap is snug against the child (page 39).
- Harness straps **MUST** be on the child's shoulders and snug, with no more than two-fingers width of space between the child and the harness strap (page 38).

5. Position and connect chest clip.

Chest clip/harness tie **MUST** be at armpit level (page 38).

6. Check your work.

- Recline stand is flipped to the *upright* position (page 34).
- The child restraint **DOES NOT** move more than 25 mm (1 inch) forward or side-to-side (pages 26 and 30).
- The child's back and bottom are flat against the back and bottom surfaces of the child restraint (page 38).
- Shoulder harness straps **MUST** start at or above shoulder height, AND you must use the strap slots closest to your child's shoulders (page 32).
- Buckle tongues are fully engaged (page 38).



Installing Your Child Restraint Rear-facing Using a Seat Belt

1



⚠ WARNING

NEVER turn a child restraint forward-facing with an infant who weighs less than 10 kg (22 lbs) or who is less than one year of age. Crash forces may cause serious injury or death.

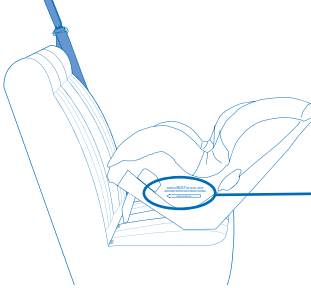

Infants **MUST** always ride facing the rear of the vehicle. The back of the child restraint supports and protects the baby and absorbs crash forces. Adjust the child restraint to the *recline position* (page 34). Place the child restraint in your vehicle **rear-facing**. Adjust the restraint so that the level arrow **A** is level with the ground.

2

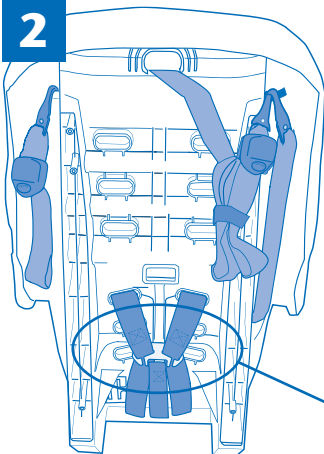

Attach the harness straps **B** to the splitter plate **C** using the *infant position* (page 33) on the harness straps. As your child grows, you can attach the harness straps **B** to the splitter plate using the pockets at the end of the straps.

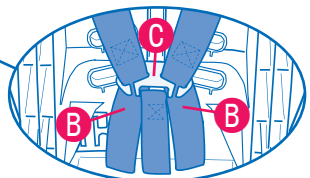



3

! WARNING

DO NOT use the two upper harness slots **rear-facing**. The harness may not properly restrain the child during a crash.

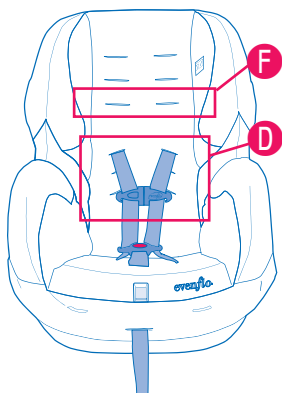

Make sure the harness straps are in one of the **three lower strap slots D**. The harness straps should start at shoulder height or lower, using the strap slots closest to your child's shoulders **E**, as shown.



U.S. Customers Only: For a taller child, the fourth set of harness slots **F** can be used. **Note:** These slots **MUST** start at shoulder height or lower and be the closest slots to your child's shoulders.

4

Lap Belt Only

Lap & Shoulder Belt Combination

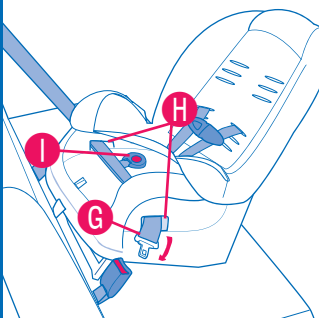
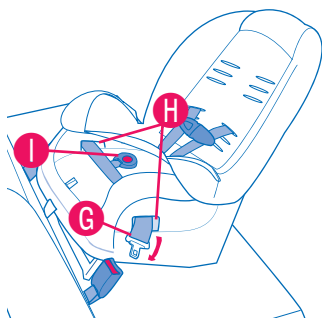

Pull the seat pad off of the front of the child restraint. Route the vehicle seat belt **G** through the rear-facing belt path **H** and continue through the opposite opening of the child restraint. **IMPORTANT:** Make sure the seat belt **G** is **in front of the crotch strap I**, as shown. Fasten the vehicle seat belt depending on your type of seat belt.

Note: You **MUST** use a locking clip with lap/shoulder seat belt combinations that have a buckle tongue that slides freely along the belt without locking into place. To install a locking clip, refer to page 36.



5

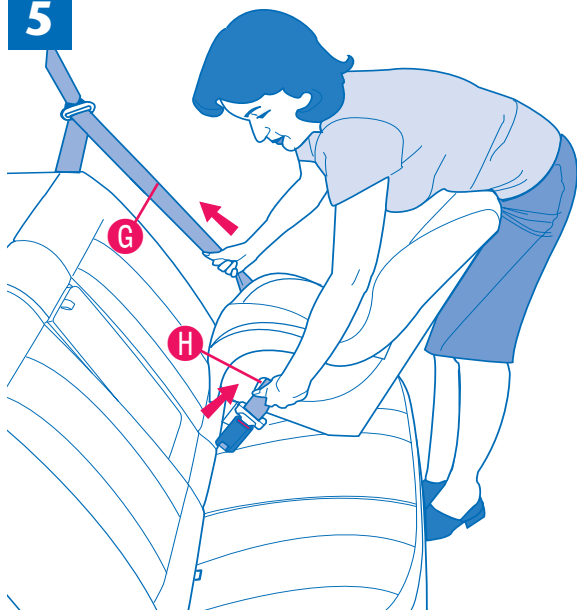

! WARNING

- If vehicle seat belts are not routed and fastened correctly, the child restraint may not protect your child in a crash.
- **DO NOT** use this child restraint if it moves more than 25 mm (1 inch) forward or side-to-side at the vehicle belt path. Serious injury or death may result from poor installation. If you cannot tightly secure the child restraint, try again or move it to another location.

The seat belt must be as tight as possible.

Put your full weight onto the child restraint as you tighten the seat belt **G**.

Check your work. If you can move the child restraint more than 25 mm (1 inch) forward or side-to-side at the belt path **H**, the seat belt is not tight enough, and you **MUST** try again.



Installing Your Child Restraint Rear-facing Using the LATCH System

LATCH is a system for attaching the child restraint to your vehicle seat. It is to be used in place of your vehicle's seat belts and can be used in vehicles with LATCH anchors. Your vehicle owner's manual may refer to this system as ISOFIX or Universal Anchorage System (UAS).

! WARNING

- **ONLY** use for securing child restraint to lower LATCH anchor points.
- **ALWAYS** read and follow exactly the instructions that accompany your vehicle and child restraint.
- **NEVER** attach two hooks to one vehicle lower anchor point.
- **DO NOT** use the vehicle seat belts to install a child restraint when using the LATCH system.
- **ONLY** use the LATCH system as described in these instructions. Serious injury or death may result from misuse.
- **ALWAYS** be sure that the LATCH hook is fully engaged onto the LATCH anchor point by pulling hard on the LATCH harness. If it is not totally engaged, the LATCH system will not secure your child restraint. Serious injury or death may result.
- To avoid a strangulation hazard, you **MUST** store the unused LATCH harness, with all slack removed, in the storage area on the back of the seat. Roll or fold the excess LATCH strap and secure with a rubber band to prevent serious injury to vehicle occupants.
- In addition to these instructions, read and follow your vehicle owner's manual regarding installation of child restraints and LATCH. If there is a discrepancy, follow your vehicle owner's manual.



1 **! WARNING**

NEVER turn a child restraint forward-facing with an infant who weighs less than 10 kg (22 lbs) or who is less than one year of age. Crash forces may cause serious injury or death.

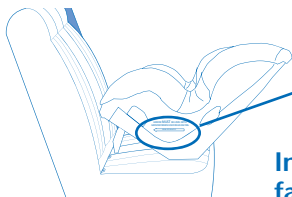
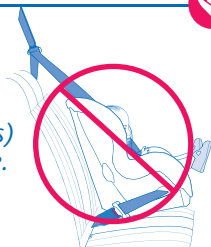

Infants **MUST** always ride facing the rear of the vehicle.

The back of the child restraint supports and protects the baby and absorbs crash forces.

Adjust the child restraint to the *recline position* (page 34). Place the child restraint in your vehicle **rear-facing**. Adjust the restraint so that the level arrow **A** is level with the ground.

2

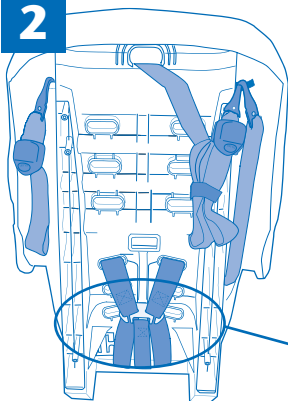

Attach the harness straps **B** to the splitter plate **C** using the *infant position* (page 33) on the harness straps. As your child grows, you can attach the harness straps **B** to the splitter plate using the pockets at the end of the straps.

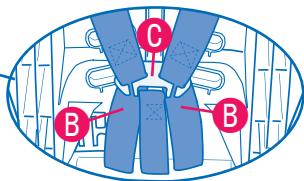

3

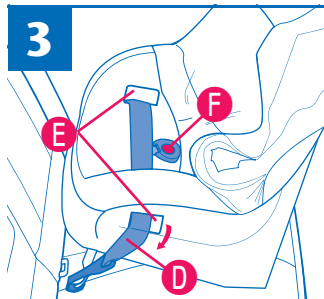

Pull seat pad from front of child restraint.

Route the LATCH strap **D** through the rear-facing belt path **E**.

IMPORTANT: Make sure the LATCH strap **D** is **in front of the crotch strap **F****, as shown.



4

! WARNING

DO NOT use the two upper harness slots **rear-facing**. The harness may not properly restrain the child during a crash.

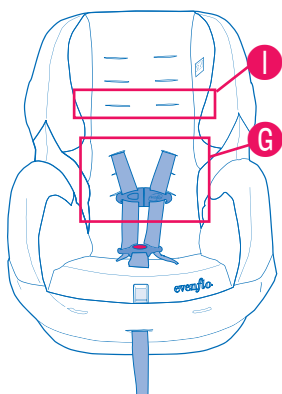

Make sure the harness straps are in one of the **three lower strap slots** **G**. The harness straps should start at shoulder height or lower, using the strap slots closest to your child's shoulders **H**, as shown.



U.S. Customers Only: For a taller child, the fourth set of harness slots **I** can be used.

Note: These slots **MUST** start at shoulder height or lower and be the closest slots to your child's shoulders.

5

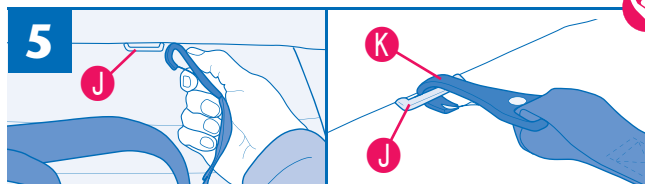

Refer to your owner's manual to locate the lower anchors **J** on your vehicle seat. Attach the right hook **K** to the right anchor **J** and the left hook to the left anchor. **DOUBLE CHECK** that the LATCH hook is fully engaged by pulling hard on the LATCH harness.

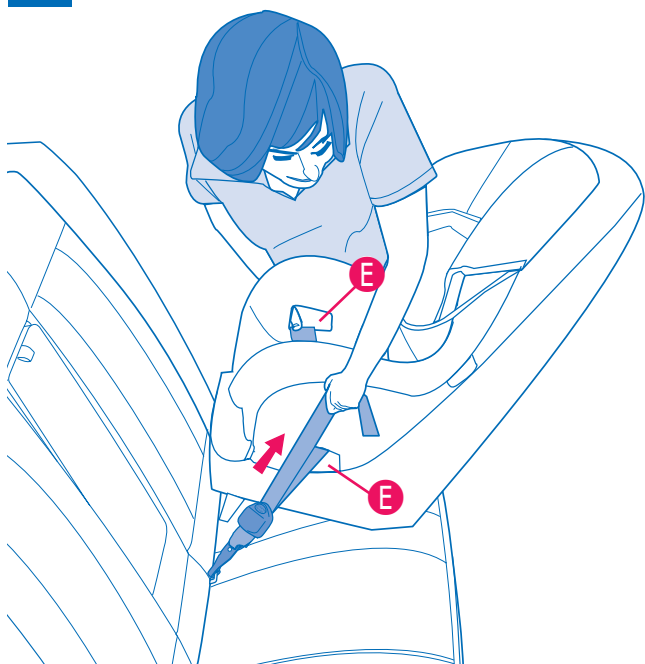

! WARNING

DO NOT use this child restraint if it moves more than 25 mm (1 inch) forward or side-to-side at the vehicle belt path. Serious injury or death may result from poor installation. If you cannot tightly secure the child restraint, try again or move it to another location.

The LATCH harness must be as tight as possible. Using your full weight, push the child restraint firmly onto the vehicle seat while pulling up on the LATCH strap to tighten.

Check your work. If you can move the child restraint more than 25 mm (1 inch) forward or side-to-side at the belt path **E**, the LATCH harness is not tight enough. You will need to try again or find another location for your child restraint.

To remove the LATCH system, go to page 42.



Installing Your Child Restraint Forward-facing Using a Seat Belt

1

⚠ WARNING

DO NOT use the three lower harness slots **forward-facing**. The harness may not properly restrain the child in the event of a crash.

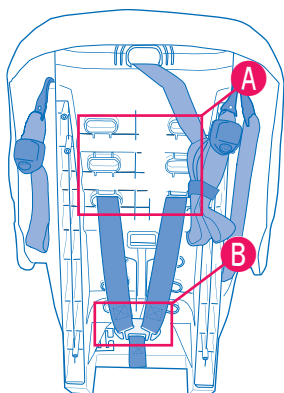

Make sure that the harness straps are in one of the three **upper strap slots** **A** and the splitter plate is attached to the bottom of the harness strap in the **toddler position** **B** (page 33). This will provide more room for your toddler to fit comfortably.

2



Adjust the child restraint to the **upright position** (page 34). Place the child restraint in your vehicle **forward-facing**.

3

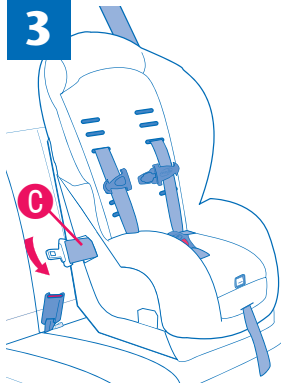

⚠ WARNING

If the vehicle belts are not routed and fastened correctly, the child restraint may not protect your child in a crash.

Thread the vehicle seat belt **C** through the child restraint.

Note: Lift the pad away for easier access.

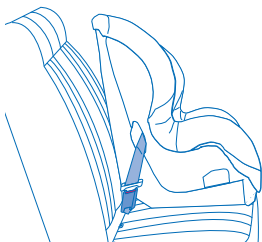
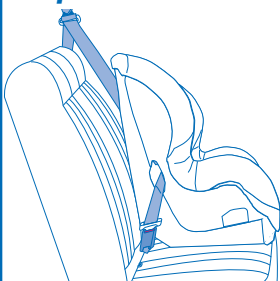
**4****Lap Belt Only****Lap & Shoulder Belt**

Fasten the vehicle seat belt as shown, depending on your type of seat belt.

Note: You **MUST** use a locking clip with lap/shoulder seat belt combinations that have a buckle tongue that slides freely along the belt without locking into place. To install a locking clip, refer to page 36.

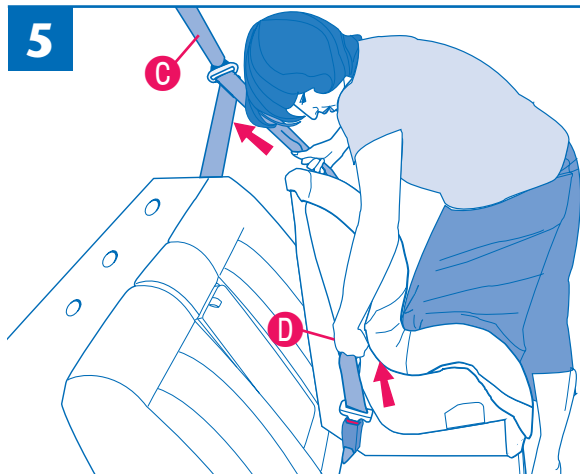
5

⚠ WARNING

DO NOT use this child restraint if it moves more than 25 mm (1 inch) forward or side-to-side at the vehicle belt path. Serious injury or death may result from poor installation. Move the child restraint to another seating location or try to tighten the seat belt again.

The seat belt must be as tight as possible.

Using your knee, put your full weight onto the seat as you tighten the seat belt **C**.

Check your work. If you can move the child restraint more than 25 mm (1 inch) forward or side-to-side at the vehicle seat belt path **D**, the seat belt is not tight enough, and you will need to try again.

**6**

! WARNING

- Failure to follow these instructions could result in serious injury to your child or other vehicle occupants.
- The tether strap is for **forward-facing use only**.

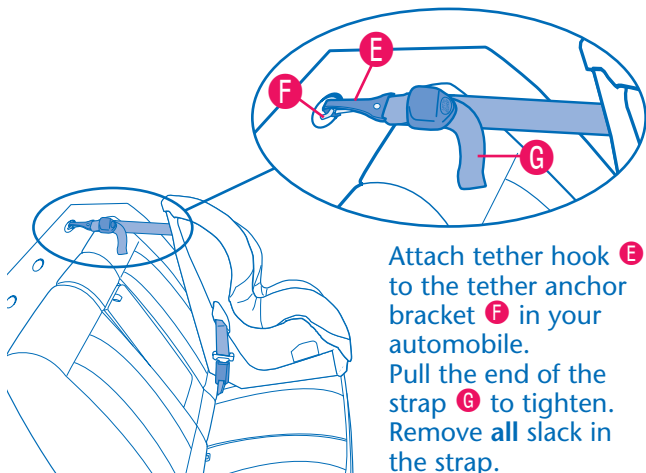

Attach tether hook **E** to the tether anchor bracket **F** in your automobile. Pull the end of the strap **G** to tighten. Remove **all** slack in the strap.

! WARNING

- To avoid a strangulation hazard, you **MUST** tightly roll or fold excess tether strap and secure with the strap/rubber band.
- Attach the tether hook to the storage clip when not in use. This will keep an unused tether from hitting someone during a crash.

After adjusting the top tether strap, you may have excess strap; **DO NOT** cut it off. If you do, it may not be long enough to use in another vehicle. Instead, **tightly roll up the excess tether strap and place the rubber band around the bundle.**

Note: Refer to your **vehicle owner's manual** for the location of the tether anchor bracket in your vehicle. Older vehicles may not come equipped with anchor bracket hardware. Check with your vehicle dealer. If you have questions regarding tether anchors that are not addressed by the vehicle owner's manual or answered by an authorized dealer/vehicle manufacturer, call Evenflo's ParentLink at **1-800-233-5921 (U.S.) or 1-937-773-3971 (Canada).**



Installing Your Child Restraint Forward-facing Using the LATCH System

LATCH is a system for attaching the child restraint to your vehicle seat. It is to be used in place of your vehicle's seat belts and can be used in vehicles with LATCH anchors. Your vehicle owner's manual may refer to this system as ISOFIX or Universal Anchorage System (UAS).

IMPORTANT: Use vehicle belt (not LATCH connectors) for internal harness installations with children weighing more than 24.9 kg (55 lbs).

⚠ WARNING

- **ONLY** use for securing child restraint to lower LATCH anchor points.
- **ALWAYS** read and follow exactly the instructions that accompany your vehicle and child restraint.
- **NEVER** attach two hooks to one vehicle lower anchor point.
- **DO NOT** use the vehicle seat belts to install a child restraint when using the LATCH system.
- **ONLY** use the LATCH system as described in these instructions. Serious injury or death may result from misuse.
- **ALWAYS** be sure that the LATCH hook is fully engaged onto the LATCH anchor point by pulling hard on the LATCH harness. If it is not totally engaged, the LATCH system will not secure your child restraint. Serious injury or death may result.
- To avoid a strangulation hazard, you **MUST** store the unused LATCH harness, with all slack removed, in the storage area on the back of the seat. Roll or fold the excess LATCH strap and secure with a rubber band to prevent serious injury to vehicle occupants.
- In addition to these instructions, read and follow your vehicle owner's manual regarding installation of child restraints and LATCH. If there is a discrepancy, follow your vehicle owner's manual.

**1**

! **WARNING**

DO NOT use the three lower harness slots **forward-facing**. The harness may not properly restrain the child in the event of a crash.

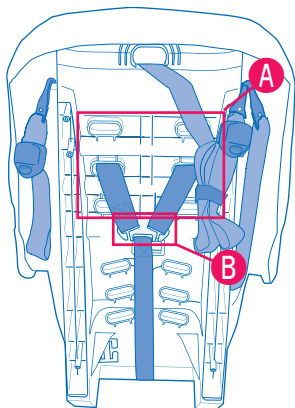

Make sure that the harness straps are in one of the three **upper strap slots** **A** and the splitter plate is attached to the bottom of the harness strap in the **toddler position** **B** (page 33). This will provide more room for your toddler to fit comfortably.

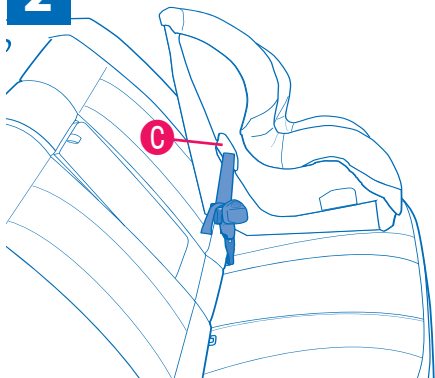
2

Adjust the child restraint to the **upright position** (page 34) and place it in your vehicle **forward-facing**, as shown. Route the LATCH harness and hook through each side of the forward-facing belt path **C**.

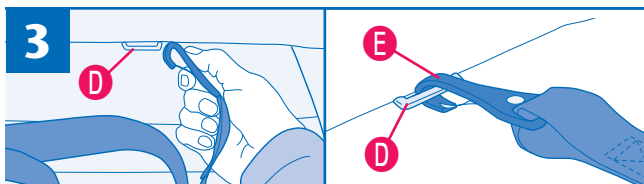

Refer to your owner's manual to locate the lower anchors **D** on your vehicle seat. Attach the right hook **E** to the right anchor **D** and the left hook to the left anchor.

DOUBLE CHECK that the LATCH hook is fully engaged by pulling hard on the LATCH harness.

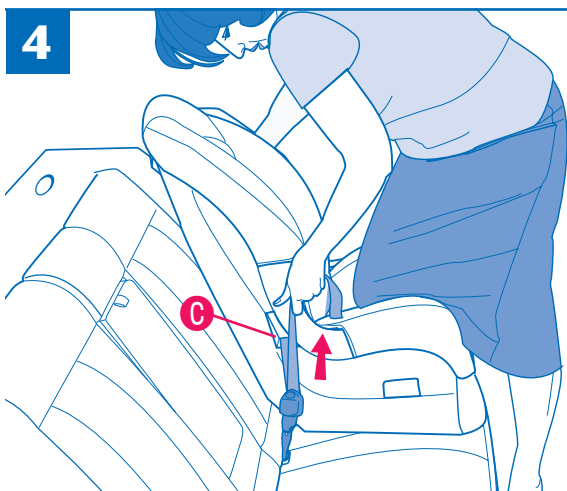

WARNING

DO NOT use this child restraint if it moves more than 25 mm (1 inch) forward or side-to-side at the vehicle belt path. Serious injury or death may result from poor installation. If you cannot tightly secure the child restraint, try again or move it to another location.

The LATCH harness must be as tight as possible.

Using your full weight, push the child restraint firmly onto the vehicle seat while pulling up on the LATCH strap to tighten.

Check your work. If you can move the child restraint more than 25 mm (1 inch) forward or side-to-side at the belt path **C**, the LATCH harness is not tight enough. You will need to try again or find another location for your child restraint.

To remove the LATCH system, go to page 42.

**5**

! WARNING

- Failure to follow these instructions could result in serious injury to your child or other vehicle occupants.
- The tether strap is for **forward-facing use only**.

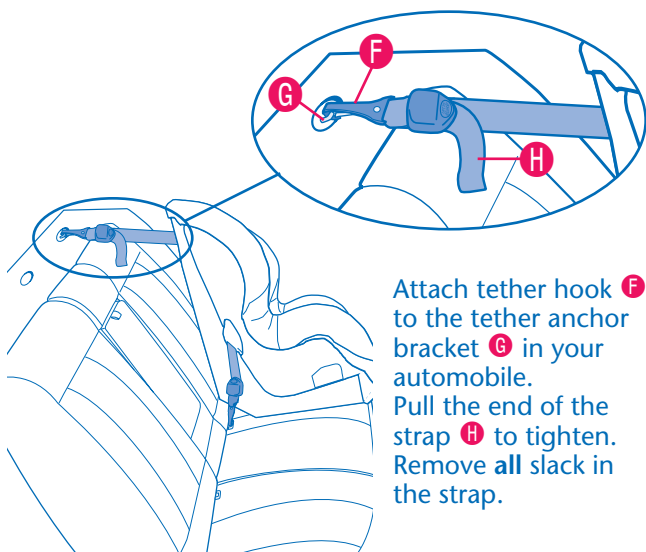

Attach tether hook **F** to the tether anchor bracket **G** in your automobile. Pull the end of the strap **H** to tighten. Remove **all** slack in the strap.

! WARNING

- To avoid a strangulation hazard, you **MUST** tightly roll or fold excess tether strap and secure with the strap/rubber band.
- Attach the tether hook to the storage clip when not in use. This will keep an unused tether from hitting someone during a crash.

After adjusting the top tether strap, you may have excess strap; **DO NOT** cut it off. If you do, it may not be long enough to use in another vehicle. Instead, **tightly roll up the excess tether strap and place the rubber band around the bundle.**

Note: Refer to your **vehicle owner's manual** for the location of the tether anchor bracket in your vehicle. Older vehicles may not come equipped with anchor bracket hardware. Check with your vehicle dealer. If you have questions regarding tether anchors that are not addressed by the vehicle owner's manual or answered by an authorized dealer/vehicle manufacturer, call Evenflo's ParentLink at **1-800-233-5921 (U.S.) or 1-937-773-3971 (Canada).**

Positioning the Harness Strap

U.S. Customers Only:

B

Rear-facing and Forward-facing

This set of harness slots can be for either forward-facing or rear-facing use.

U.S. and Canadian Customers:

A

Rear-facing ONLY

Bottom Three Harness Positions

C Forward-facing ONLY

Top Two Harness Positions

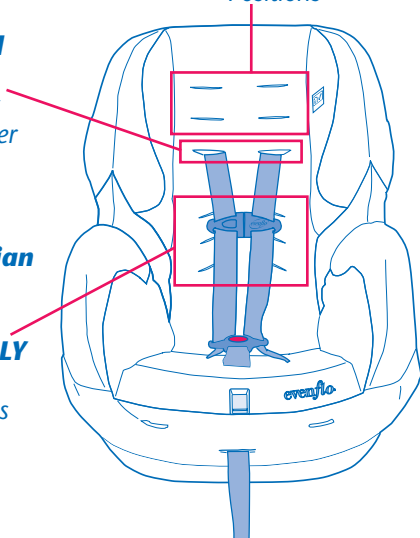

Shoulder harness straps on this child restraint are adjustable to six positions.

U.S. Customers Only: Rear-facing, the shoulder harness straps **MUST** start at or below shoulder height using the strap slots closest to your child's shoulders in one of the four lower harness positions **A** and **B**. The child's head **MUST** be at least 25 mm (1 inch) below the top of the seat back.

Canadian Customers: Rear-facing, the shoulder harness straps **MUST** start at or below shoulder height using the strap slots closest to your child's shoulders in one of the three lower harness positions **A**. The child's head **MUST** be at least 25 mm (1 inch) below the top of the seat back.

U.S. and Canadian Customers: Forward-facing, you **MUST** use one of the top three harness positions **B** and **C**. If the tops of the child's ears are above the top of the seat back, the child's shoulders fall above the upper harness slots, or the child weighs more than 29.4 kg (65 lbs), you **MUST** discontinue use of this child restraint. We recommend that you move your child to a larger child restraint or a booster seat. You **MUST** use the harness slots at or above the child's shoulders **AND** closest to your child's shoulders.

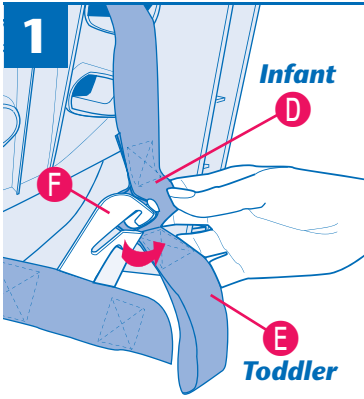

There are two positions on the harness straps. The top loop **D** is for infant use. The bottom pocket **E** is for use as your child grows. To change the harness strap position, loosen the shoulder harness as shown on page 40, step 2. Slide the harness strap off the splitter plate **F**.

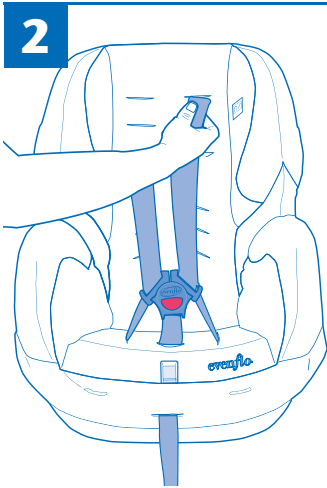

Pull harness strap through to the front of the child restraint. Thread each harness strap through the appropriate slot. Pull the harness strap to the back of the child restraint.

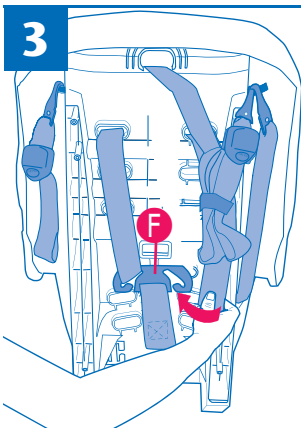

Reattach the splitter plate **F** to the appropriate pocket on the harness strap.

Adjusting the Recline Stand

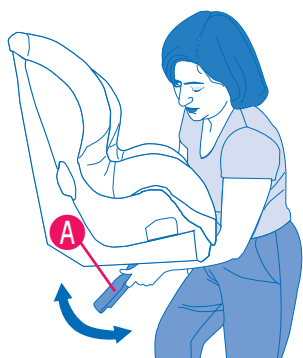

Lift the child restraint and flip the recline stand **A**, located under the child restraint seat, to either the *upright* or *recline* position.

Note: Recline position is to be used for rear-facing **ONLY**.

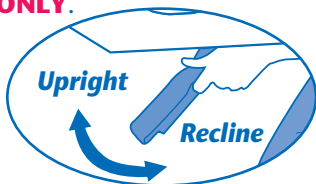

FOR CANADIAN CONSUMERS ONLY:

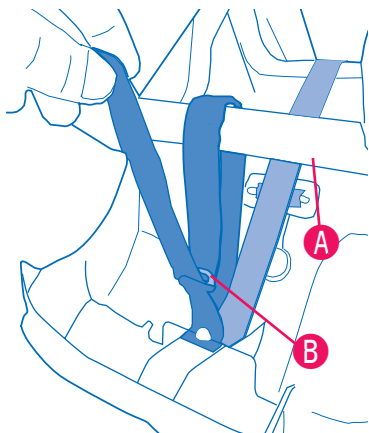

Wrap Velcro® strap around the recline stand **A** and insert the end of the strap through the D-ring **B**, as shown.

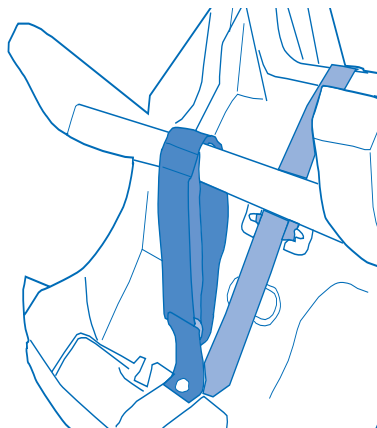

Pull tightly and adhere Velcro® to itself, as shown.

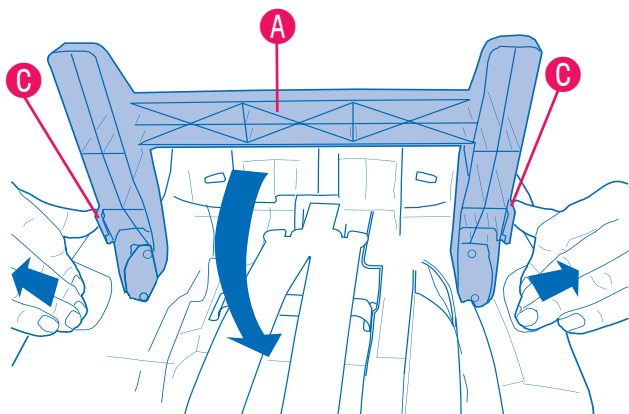

To fold the recline stand **A**, turn the child restraint upside down. Pull the shell walls away from the locking tabs **C** on the sides of the recline stand and rotate the recline stand downward until it lies flat, as shown.

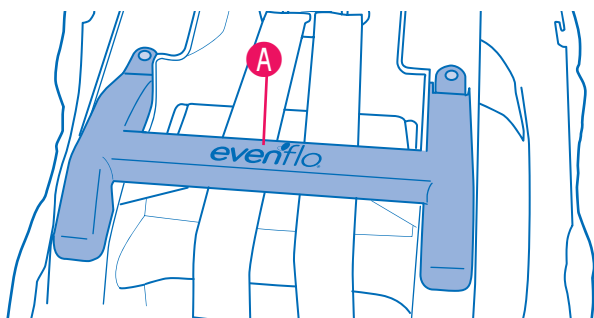

Rear-facing Recline

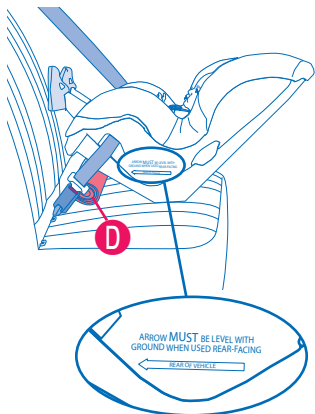

The child restraint **MUST** be in the **RECLINE** position for rear-facing infant use. Child **MUST** weigh 2.3 to 18 kg (5 to 40 lbs).

If the level line is not parallel to the ground, use a tightly rolled towel or small blanket **D** beneath the front edge of the recline stand.

Forward-facing Upright

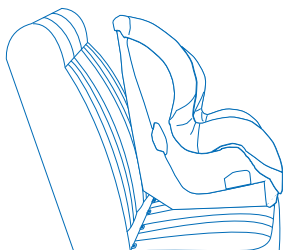

The child restraint **MUST** be in the **UPRIGHT** position for forward-facing toddler use.

Child **MUST** weigh 10 to 29.4 kg (22 to 65 lbs) and be at least one year of age.

Using the Locking Clip

To view a video about installing a locking clip, go to www.evenflo.com.

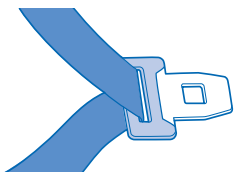

Use the locking clip with:

- Lap/shoulder seat belt combinations that have a buckle tongue that slides freely along the belt without locking into place; **OR**
- Seat belts equipped with an emergency locking retractor (ELR). Some ELR vehicle belts can be switched so that they lock when tightened. **It may not be necessary to use a locking clip in these situations.**

Locking Clip

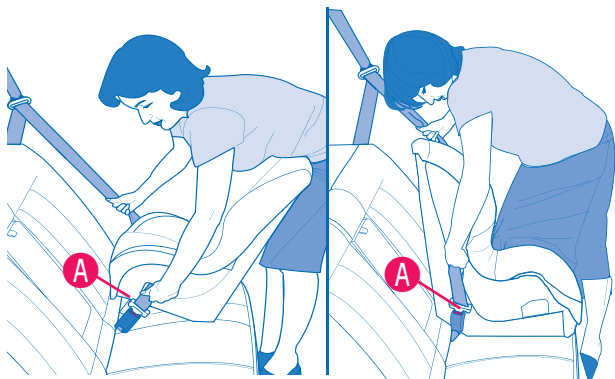

Consult your vehicle owner's manual before installing the locking clip.

1**Rear-facing
Installation****Forward-facing
Installation**

Using your full weight, press down on the child restraint as you tighten the seat belt. While holding the lap and shoulder belts together just behind the free sliding buckle tongue **A**, unfasten the seat belt.

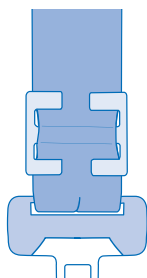
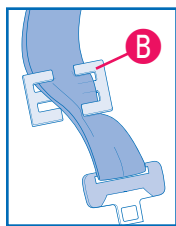
2

Locking clip **MUST** be placed within **13 mm (0.5 in.)** of buckle tongue.

Thread the locking clip **B** onto the seat belt and slide it into place.

Re-buckle the seat belt. Locking clip must be placed within 13 mm (0.5 inch) of buckle tongue.

! WARNING

Remove locking clip from vehicle seat belt when not used with a child restraint, or the vehicle seat belt will not properly restrain an adult or child. Serious injury could occur.

Securing Your Child



Place baby in the child restraint. **The baby's back and bottom should be flat against the restraint.** If there is a gap, the baby will not be comfortable.

1

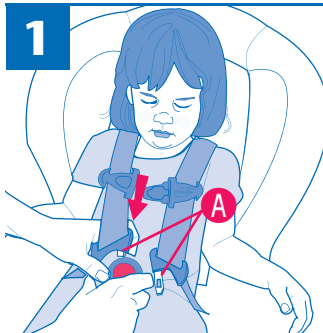

Bring each harness strap over the child's shoulders. Insert the buckle tongues **A** into the buckle.

Pull up on the harness strap to check that the buckle tongues are fastened.

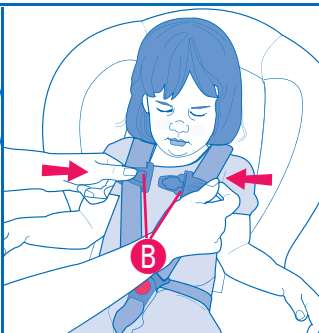

Fasten the chest clip **B** by snapping the two halves together, as shown.

Slide chest clip to armpit level.

2

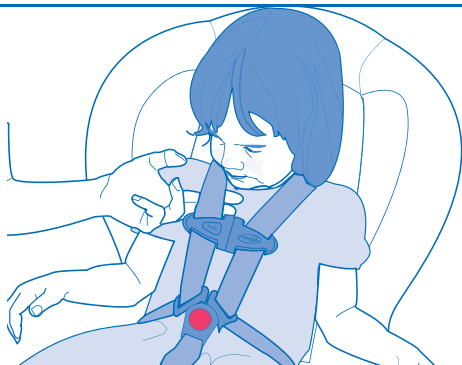

The harness straps must be snug against the child. A snug strap should not allow any slack. It should lay in a relatively straight line without sagging. It should not press on the child's flesh or push the child's body into an unnatural position. Check the harness straps near the shoulders for slack and adjust as needed.

Adjusting the Crotch Strap

This Child Restraint Has Two Buckle Harness Positions

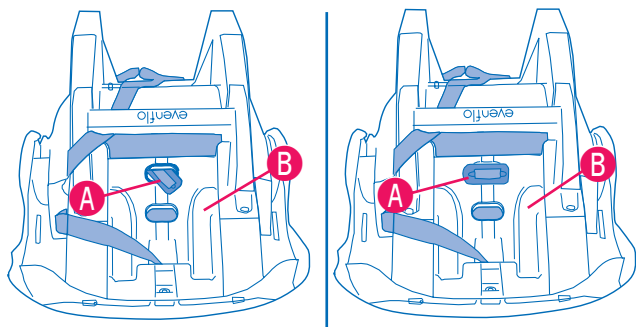

To reposition the crotch strap, first turn the child restraint upside down. Turn the crotch strap harness anchor **A** sideways and push it through the slot in the bottom of the seat shell **B**.

Reposition the harness anchor into the other slot. Make certain the harness anchor is properly seated against the seat shell **B**.

Note: The crotch strap should be snug against the child. Choose the slot that is closest to the child AND the most comfortable for the child but **NEVER** under the child's bottom.

For Newborn Position

Place the anchor **A** through the rear slot, then feed it through the front slot.

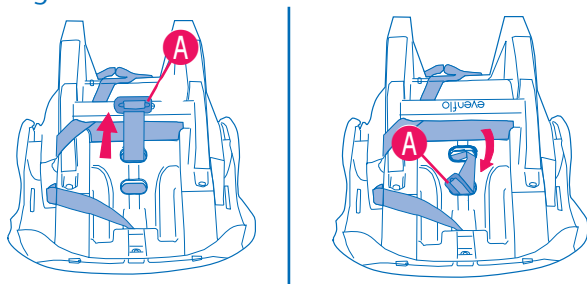

Make sure the anchor is completely through the front slot and is lying flat against the bottom of the seat.



IMPORTANT: Do not use this configuration for infants weighing more than 4.5 kg (10 lbs).

Adjusting the Harness Strap

1

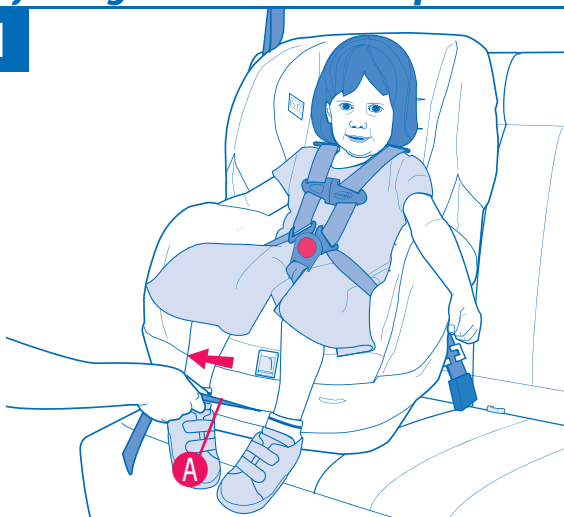

To tighten the harness straps, pull on the long harness adjuster strap **A** on the front of the seat.

2

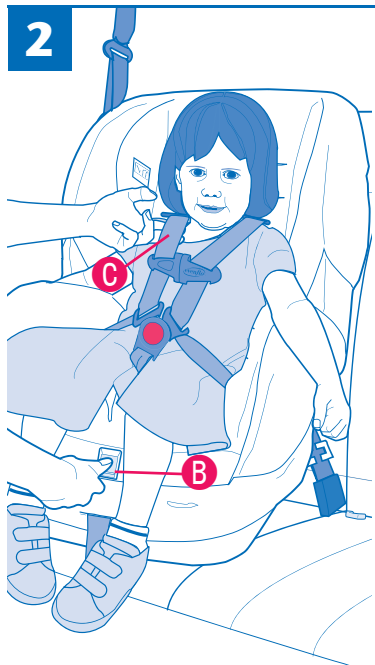

To loosen the harness straps, push the harness release button **B** on the front of the seat. At the same time, pull up on the harness strap **C** near the child's shoulders.

Removing Your Child from the Restraint

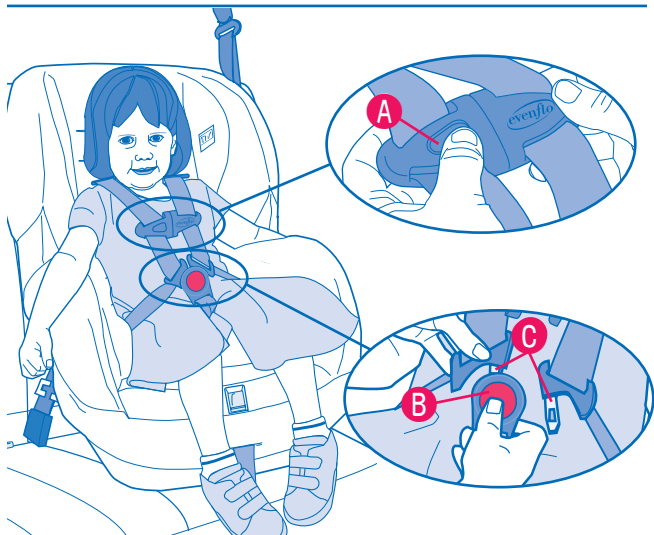

Push the release button **A** and pull the chest clip apart. Press the red buckle release **B** and remove the buckle tongues **C**.

Removing the Tether Strap



1

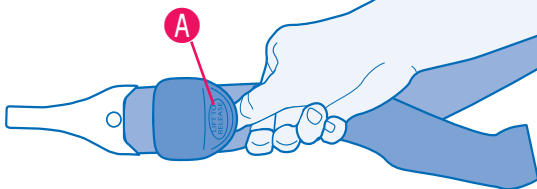

Tilt the adjuster **A** and slide the strap to loosen.

2

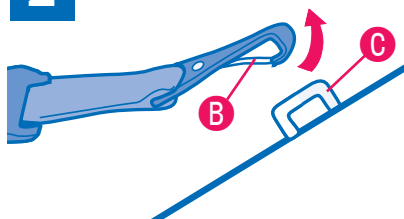

Press the tab **B** and twist, then remove the hook from the anchor **C**.

3

! WARNING

- To avoid a strangulation hazard, you **MUST** tightly roll or fold excess tether strap and secure with the strap/rubber band.
- Attach the tether hook to the storage clip when not in use. This will keep an unused tether from hitting someone during a crash.

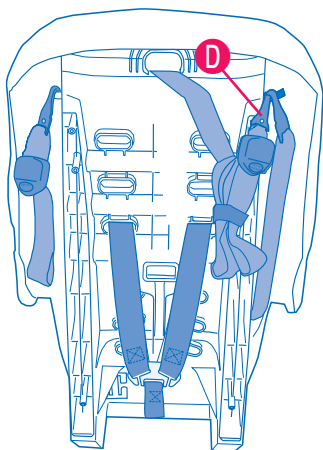

When the tether strap is not in use, you **MUST** attach the hook **D** to the back of the child restraint and tightly roll and secure the strap with the strap/rubber band. A loose tether strap and hook may injure your child.

Removing the LATCH System

1

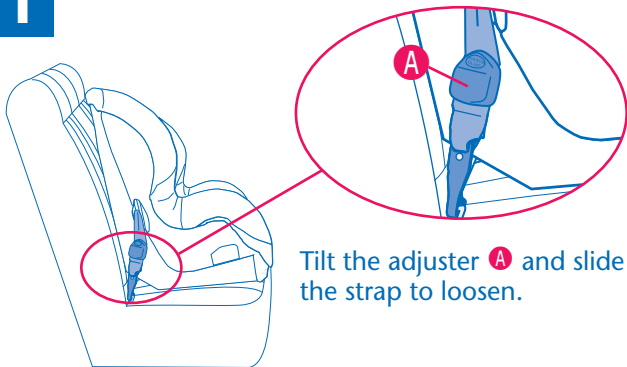

Tilt the adjuster **A** and slide the strap to loosen.

2

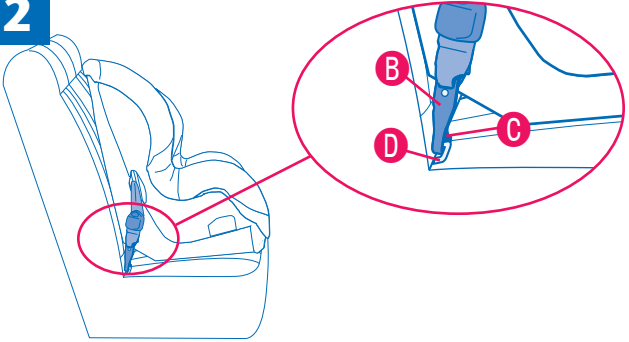

To remove the hook **B**, press the tab **C** and twist, then remove from anchor **D**.

3

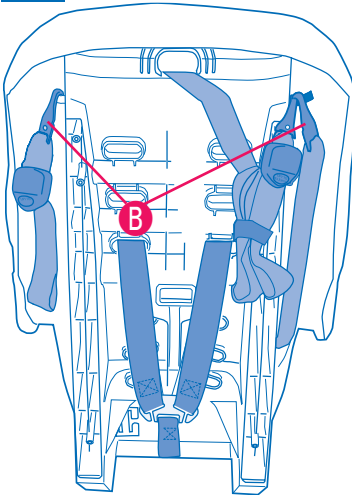

When the LATCH system is not in use, you **MUST** attach the hooks **B** to the back of the child restraint. A loose LATCH harness strap and hook may injure your child.

Installing the Accessories

Not available on all models.

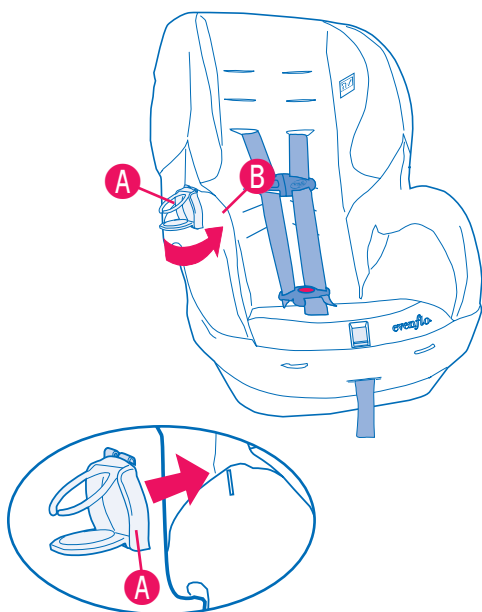

⚠ WARNING

- Use the fold-down cup holder with the child restraint in the **forward-facing** position **ONLY**.
- **DO NOT** use the accessories to store cans or hard cups. Only for use with soft cups (such as styrofoam or paper).
- **DO NOT** place any cups that contain hot liquids (such as coffee or tea) in the accessories.
- **DO NOT** snap any other items to this child restraint unless it has been certified for use with this specific child restraint.

To install the fold-down cup holder **A**, move seat pad **B** out of the way and install the cup holder onto the side of the restraint.

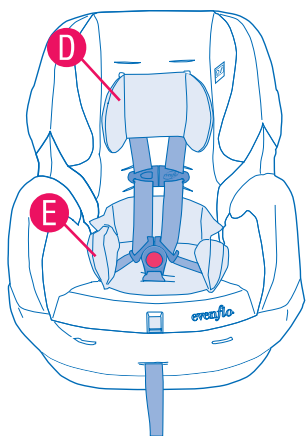

The optional Head Pillow **D** attaches easily and helps support the child's head.

The optional Body Pillow **E**, when placed in the restraint, as shown, helps support your child.

Replacement Parts

Not available on all models. Styles may vary.

To order replacement parts, you can order online at www.evenflo.com or contact Evenflo. When you contact us, please have the product model number and date of manufacture (found on the back of the child restraint).



1 Locking Clip



2 Chest Clip



3 Crotch Strap

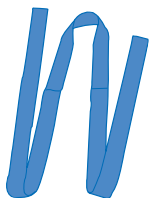

4 Harness

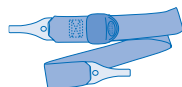

5 LATCH Harness



6 Tether

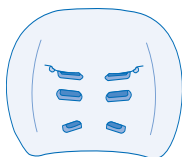

7 Head Foam



8 Cup Holder

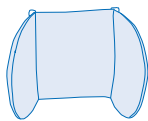

9 Head Pillow

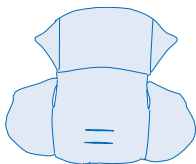

10 Body Pillow

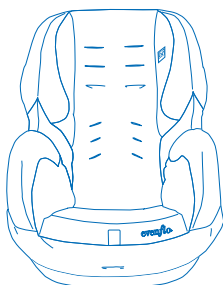

11 Seat pad

Proper Disposal of This Child Restraint

At the end of this child restraint's useful life, Evenflo encourages you to dispose of it properly. Most of the components in this child restraint are recyclable.

1. Remove all fabric and padding.
2. Remove all screws and disassemble the restraint.
3. Recycle all plastic/foam parts and discard the rest.

If your local recycling center won't accept the padding, you may dispose of it in the landfill.

NOTE: Evenflo uses recycled materials in the manufacturing process whenever possible but never for components that are critical for safety.

Limited Warranty

For a period of 90 days from the original purchase of this Product, Evenflo warrants to the original end user (“Purchaser”) this Product (including any accessories) against defects in material or workmanship. Evenflo’s sole obligation under this express limited warranty shall be, at Evenflo’s option, to repair or replace any Product that is determined to be defective by Evenflo and determined to be covered by this warranty.

Repair or replacement as provided under this warranty is the exclusive remedy of the Purchaser. Proof of purchase in the form of a receipted invoice or bill of sale evidencing that the Product is within the warranty period must be presented to obtain warranty service. This express limited warranty is extended by Evenflo ONLY to the original Purchaser of the Product and is not assignable or transferable to subsequent purchasers or end users of the Product. For warranty service, contact Evenflo’s ParentLink Consumer Resource Center.

EXCEPT TO THE EXTENT PROHIBITED BY APPLICABLE LAW, ANY IMPLIED WARRANTY OF MERCHANTABILITY OR FITNESS FOR A PARTICULAR PURPOSE ON THIS PRODUCT IS HEREBY DISCLAIMED. EVENFLO SHALL NOT BE LIABLE FOR ANY INCIDENTAL, CONSEQUENTIAL, SPECIAL OR PUNITIVE DAMAGES OF ANY KIND FOR BREACH OF THE EXPRESS LIMITED WARRANTY ON THIS PRODUCT, OR ANY WARRANTY IMPLIED BY OPERATION OF LAW. OTHER THAN THE EXPRESS LIMITED WARRANTY SET FORTH ABOVE, THERE ARE NO OTHER WARRANTIES THAT ACCOMPANY THIS PRODUCT AND ANY ORAL, WRITTEN OR ANY OTHER EXPRESS REPRESENTATION OF ANY KIND IS HEREBY DISCLAIMED.

ParentLink®

answers. advice. affirmation.™

• **www.evenflo.com**

- **USA: 1-800-233-5921 8 AM – 5 PM E.T.**
- **Canada: 1-937-773-3971**
- **México: 01-800-706-12-00**

ParentLink®

answers. advice. affirmation.™

• **www.evenflo.com**

- *USA: 1-800-233-5921 8 AM – 5 PM E.T.*
- *Canada: 1-937-773-3971*
- *México: 01-800-706-12-00*