



Wherever you go, there we are.®

Surface Applied (Retrofit) TWSI Submittal Package



ADA Solutions, LLC.

323 Andover Street

Suite 3

Wilmington, MA 01887

Tel: 800-372-0519

Fax: 978-262-9125

www.adatale.com

ADA Solutions, LLC. appreciates your interest in the Surface Applied Tactile Walking Surface Indicator (TWSI) Panels. Our Tactile Walking Surface Indicator (TWSI) Panels are easy to install and are made with HD exterior-grade fibreglass reinforced polymer composite material. (TWSI) Panels are also known as; Detectable Warning Tiles, Tactile Warning Plates and ADA Pads.

This informative submittal package includes:

- **Product data sheet**
- **Product specifications**
- **Installation manuals**
- **Detail drawings**
- **Test results**
- **Cleaning and maintenance instructions**
- **Sample warranty form**
- **Sample certificate of compliance**
- **Standard colours**

The information contained within this submittal document details the various design and functionality features that make ADA Solutions, LLC. TWSI Panels best suited for your project requirements. However, if you require any additional information, such as project-specific detail drawings and specifications, we would be pleased to produce expedited detailed documents to address your project requirements specifically.

The principal features and benefits of ADA Solutions, LLC. TWSI Panel System represents the latest design innovations for tactile warning and alert indicator panels. The primary features and benefits of ADA Solutions, LLC. TWSI Panel Systems include but are not limited to the following:

- Industry-leading Anti-Slip Surface
- Fibreglass Reinforced Polymer Composite Material throughout the panel body including raised truncated domes
- Matte finish with uniform colour throughout the entire panel
- SA-TWSI does not rely on surface coatings or paint for colour and UV stabilization.
- 60mm (2.35") Centre to Centre Dome Spacing – AODA/OBC/CSA/ISO Compliant
- Tactile body thickness is 4.8mm (3/16") with four (4) 12.7mm (1/2") bevelled edges
- Stainless steel pins with a 6.35mm x 38mm (1/4" x 1 1/2") composite sleeve anchors included with each panel
- 296mL (10 oz.) cartridge of Chem-Link M1 Structural Adhesive included with each panel
- Available in various sizes and colours
- Industry-leading Seven (7) Year Warranty
- Manufactured in an ISO 9001 QC Approved Facility
- Complies with all ASTM & ULC Test Requirements

By specifying ADA Solutions, LLC. Surface Applied TWSI Panels ensures consistent, hassle-free, fully compliant installations each time. The use of ADA Solutions, LLC. Surface Applied with an inline truncated dome pattern on all curb ramps and walking surfaces at the locations and to the dimensions shown on the drawings, by the contract documents and as directed by the project owner. Surface Applied Tactile panels are also known as Surface Mount Tactile Warning Tiles or Retrofit Tactile Warning Tiles.

We trust this overview of ADA Solutions, LLC. Surface Applied TWSI Panel System, together with the information contained in our submittal package, helps determine the ADA Solutions, LLC. Surface Applied TWSI Panel System best suited to your project requirements. If you would like to speak directly with me or customer service representatives, please call us directly by dialling Toll-Free at (800) 372-0519 or my number below.

Yours truly,

Sandro Pinto
Sales Manager - Canada

ADA Solutions, LLC.
spinto@surewerx.com
Cell: 905-699-3999

SURFACE APPLIED TACTILE WALKING SURFACE INDICATOR PANELS

SECTION 1 - GENERAL

1.01 RELATED DOCUMENTS

- A. Drawings and general provisions of Contract, including General and Special Conditions and Division 1 Specifications Section, apply to this Section.
- B. ISO 23599:2018 - Assistive Products for Blind and Vision-Impaired Persons - Tactile Walking Surface Indicators.
- C. ISO 21542:2011 - Building Construction - Accessibility and Usability of the Built Environment.
- D. CSA B651-18 - Accessible Design for the Built Environment.
- E. Accessibility for Ontarians With Disabilities Act (AODA), 2005 - O. Reg. 413/12: Integrated Accessibility Standards Regulation (IASR) 191/11 – Sections 80.25 to 80.29
- F. Ministry of Municipal Affairs and Housing – Ontario Building Code (OBC)
- G. National Building Code of Canada
- H. ISO 9001 – Certificate No. 0502011, ISO 1409 & ISO/B 16949 Certified Manufacturing Facility located in Jefferson, OH.

1.02 DESCRIPTION

- A. This Section includes Specifications for furnishing and installing Surface Applied Tactile Walking Surface Indicator (SA-TWSI) panels with an inline truncated dome pattern retrofitted onto all public spaces at the locations and to the dimensions shown on the Drawings, by the Contract Documents and as directed by the Engineer/Architect. (*Surface Applied TWSI is also known as Surface Mount Tactile Warning Tiles or Retrofit Tactile Warning Tiles*).

1.03 SUBMITTALS

- A. **Product Data Sheet:** Submit ADA Solutions, LLC. literature describing products, installation procedures and routine maintenance.
- B. **Samples for Verification Purposes:** Submit two (2) tactile walking surface indicators samples. Samples shall be appropriately labelled and shall contain the following information: Name of Project, Submitted by Date of Submittal, and Manufacturer's Name.
- C. **Shop Drawings:** Submit Standard Manufacturer Shop Drawings showing all pertinent characteristics of the Structural Composite Shell Surface Applied Tactile Walking Surface Indicator (SA-TWSI), including profile, sound-on-cane contact amplification feature, panel surface profile, plans of panel placement including joints, fastener locations, and material to be used as well as outlining installation materials and procedures.
- D. **Material Test Reports:** Submit all current test reports from qualified, accredited independent testing laboratories by ASTM and UL/Canada guidelines and indicating that materials proposed for use are in

compliance with specification requirements and meet or exceed the properties shown on these specifications. All tests conducted on a Surface Applied TWSI panel.

- E. **Maintenance Instructions:** Submit copies of the manufacturer's specified installation and maintenance practices for each type of TWSI panel and accessories as required.

1.04 QUALITY ASSURANCE

- A. Provide Surface Applied TWSI panels and accessories as produced by a single manufacturer with a minimum of five (5) years' experience in the manufacturing of Surface Applied TWSI panels.
- B. Installer's Qualifications: Engage an experienced installer certified in writing by Surface Applied TWSI panel manufacturer as qualified for installation, who has completed installations similar in material, design, and extent to that indicated for the Contract.
- C. Surface Applied Tactile Walking Surface Indicator Panels (SA-TWSI) shall meet or exceed the following test criteria using the most current test methods:

Test Reference	Test Description	Requirements
AASHTO-H20	Load Bearing at 7,257 kg (16,000lb)	No Damage
ASTM D 695	Compressive Strength	≥ 199 Mpa (29,800 psi)
ASTM D 790	Flexural Strength	≥ 202 Mpa (29,300 psi)
ASTM D 638	Tensile Strength	≥ 80 Mpa (11,600 psi)
ASTM D 696	Linear Coefficient of Thermal Expansion	2.32 x 10 ⁻⁵ / °C
ASTM C 1028	Static Coefficient of Friction	≥ 1.05 Wet / ≥ 1.18 Dry
ASTM E 84	Flame Spread Index – (Class A)	≤ 25
CAN/ULC S102.2	Smoke Developed Index – (Class A)	≤ 5
	Flame Spread Index – (Class A)	≤ 5
ASTM D 570	Water Absorption	≤ 0.10%
ASTM C 501	Abrasion Resistance (Iw)	≥ 549
ASTM G 155	Accelerated Weathering @ 2,000hrs	ΔE < 5
ASTM C 1026	Freeze/Thaw/Heat	No Disintegration
ASTM B 117	Salt Spray @ 200hrs	No Change
ASTM D 1037	Accelerated Aging	No Failure
ASTM D 543	Chemical Resistance	No Failure
ASTM 1308	Chemical Stain Testing	No Deterioration

- D. Polymer Composite Surface Applied TWSI panels are manufactured with fibreglass and carbon-reinforced polyester-based Sheet Molding Compound (SMC). An exterior grade matte finish that is homogeneous, colourfast and UV stable throughout the entire panel, including the raised truncated domes. TWSI Products that rely on surface paints, coatings or supplemental compounds are not permitted. The truncated domes must contain sufficient levels of fibreglass reinforcement to ensure durability. Panels manufactured without fibreglass reinforcement such as Vitrified Polymer Composite (VPC) shall not be used on this project. The panel shall incorporate an in-line pattern of truncated domes measuring nominal 5mm (0.2") height, 23mm (0.9") base diameter, 12mm (0.47") top diameter, and spaced centre-to-centre 60mm (2.35") as measured side by side.

E. Stamped concrete, polymer concrete or concrete pavers/tile, brick, and cast-iron TWSI Products are not acceptable for use on this project.

F. Dimensions: Surface Applied TWSI panels shall be held within the following sizes and tolerances:

Part Number	Fastener #	Part Size	
2436IDRET2	8	610mm x 931mm (24" x 36.65")	
2448IDRET2	15	610mm x 1236mm (24" x 48.65")	
2460IDRET2	18	610mm x 1540mm (24" x 60.65")	
3648IDRET2	20	915mm x 1236mm (36" x 48.65")	
3660IDRET2	24	915mm x 1540mm (36" x 60.65")	
24RADRET	16	610mmx845mm (For 3048mm, 4572mm, 6096mm radii)	24" x 33.25" (For 10', 15' and 20' radii)
Note: Tolerances (Side to Side & End to End) ± 0.1250mm (0.0049")			
Note: TWSI body thickness - 4.8mm (3/16") with four (4) 12.7mm (1/2") bevelled edges			

1.05 DELIVERY, STORAGE AND HANDLING

- A. Surface Applied TWSI panels shall be suitably packaged or crated to prevent damage in shipment and handling.
- B. Surface Applied TWSI panels shall be delivered to a location at the building site for storage before installation. Store SA-TWSI panels in an area that is within an acceptable temperature range 4°C - 32°C (40°F - 90°F) and maintain the storage facility in a clean, dry condition to prevent contamination or damage to SA-TWSI panels.

1.06 SITE CONDITIONS

- A. Environmental Conditions and Protection: Maintain a minimum temperature of 4°C (40°F) in spaces to receive Surface Applied TWSI panels for at least 24 hours before installation, during installation, and for not less than 24 hours after installation.
- B. The use of water for work, cleaning or dust control, etc. shall be contained and controlled and shall not be allowed to come into contact with the general public. Provide barricades or screens to protect the general public.

1.07 MANUFACTURER'S WARRANTY

- A. Surface Applied TWSI panels shall are warranted in writing for seven (7) years from the date of completion. The guarantee includes manufacturing defects, breakage, cracking, UV stability, deformation, workmanship and replaceability.

1.08 INSTALLATION WARRANTY

- A. Surface Applied TWSI panel installation shall are warranted in writing for two (2) years by the installer. Alternate products approved before the tendering phase must be guaranteed for three (3) years by the installer. Products must be guaranteed from defective work and loosening of panels.

SECTION 2 - PRODUCTS

2.01 MANUFACTURERS

- A. Fibreglass Reinforced Polymer Composite Surface Applied TWSI Panels by ADA Solutions, LLC. 323 Andover Street, Suite 3, Wilmington, MA 01887 – Toll-Free: (800) 372-0519, spinto@surewerx.com, www.adatile.com.
- B. Existing engineered and field-tested products, which have been in successful service for five (5) years, are subject to compliance with requirements, may be incorporated in work and shall meet or exceed the specified test criteria and characteristics. Requests for Approved Equal Status must be submitted and approved by the Owner before the Tender Phase of the Project.
- C. Colour: Colour shall be homogeneous throughout the panel and domes.

Colour	Colour Standard	Colour Description
Federal Yellow (Y)	Federal Standard 595B Table IV	Colour No. 33538
Brick Red (R)	Federal Standard 595B Table IV	Colour No. 20109
Clay Red (CR)	Federal Standard 595B Table IV	Colour No. 22144
Safety Red (SR)	Federal Standard 595B Table IV	Colour No. 31350
Black (B)	Federal Standard 595B Table IV	Colour No. 37038
Dark Gray (G)	Federal Standard 595B Table IV	Colour No. 36081
Safety Blue (B)	Federal Standard 595B Table IV	Colour No. 15187
White (W)	Federal Standard 595B Table IV	Colour No. 27925
Seattle Yellow (SY)	Federal Standard 595B Table IV	Colour No. 23594
Houston Beige		Pantone #7529C

2.02 EQUIPMENT

- A. The contractor shall provide all tools, equipment and services required for satisfactory installation. The following tools and accessories:
 - Black felt markers or carpenter's pencils
 - Mini grinder + 102mm (4") diamond cup wheel
 - A blower or Air compressor
 - Acetone (appropriate amount for installation)
 - Cleaning rags for cleaning back of panel and flooring
 - 6.35mm (1/4") x 6.35mm (1/4") square notch trowel
 - Caulking gun (for adhesive & sealant cartridges)
 - Utility knife
 - Table Saw or Skil Saw may be required if cutting is necessary
 - Rotary hammer drill + 6.35mm (1/4") masonry drill bit 127mm (5") long
 - Nylon or leather mallet
 - Countersink bit (2.54mm (0.10") depth / 1143mm (0.45") diameter) for creating additional fastener holes if necessary to secure gaps on the perimeter of the panel
 - Rounded plastic applicator or spatula for smoothing the sealant
 - Duct tape (for taping perimeter of the panels/flooring before caulking sealant)
 - Safety cones to prevent pedestrian traffic on the panels while the sealant cures

SECTION 3 - EXECUTION

3.01 PREPARATION

- A. During all flooring preparation of the Surface Applied TWSI panels, ensure the flooring is in a suitable condition.
- B. Before construction, refer any discrepancies to the Project Architect/Engineer for further instructions.
- C. Ensure that adequate safety guidelines are in place and that they are following the applicable industry and federal/provincial government standards.
- D. Before installation, the contractor is to ensure all submittals have been reviewed and approved by the Project Architect/Engineer. Surface Applied TWSI Panels shall be installed as per manufacturer's instructions.
- E. Before placement of the Surface Applied TWSI panel system, review manufacturer's instructions and the contract drawings with the contractor before the construction and refer all discrepancies to the project engineer/manager.
- F. Environmental Conditions: Air and flooring temperatures must exceed 4°C (40°F) for at least eight (8) daytime hours for a sound and proper installation. A propane torch may be used to boost the flooring temperature to expedite the cure of adhesives and sealants.
- G. Cutting of SA-TWSI panels may be required to accommodate specific site conditions. All possible attempts shall be made to minimize the cutting of the SA-TWSI panels. The minimum acceptable width of the cut of the SA-TWSI panel shall be 229mm (9").

3.02 INSTALLATION

- A. Under the Accessibility For Ontarians With Disabilities Act (AODA), 2005 - O. Reg. 413/12: Integrated Accessibility Standards Regulation (IASR) 191/11 – Sections 80.25 to 80.29, and as per ISO 23599:2018 - Assistive Products for Blind and Vision-Impaired Persons - Tactile Walking Surface Indicators, the Surface Applied Tactile Walking Surface Indicator Panels shall be set back from the curb ramp (backside) as per provincial accessibility requirements by the full width of the curb ramp (flare to flare) and $\geq 560\text{mm}$ (22") (recommended 610mm (24")) in the path of travel. Please contact ADA Solutions, LLC. Sales Manager for other layout applications relating to the accessibility code requirements.
- B. Set the panel true and square to the curb ramp area as detailed in the design drawings, so that its location can be marked on the concrete surface. A thin permanent marker works well. Remove the panel when done, marking its location. Allow 3.2mm (1/8") separation between successive SA-TWSI panels for expansion/contraction.
- C. Cutting of SA-TWSI panels may be required to accommodate specific site conditions. All possible attempts shall be made to minimize the cutting of the SA-TWSI panels. The minimum acceptable width of the cut of the SA-TWSI panel shall be 229mm (9").
- D. Before installing the SA-TWSI panels, the flooring surfaces must be inspected to ensure that they are clean, dry, free of voids, curing compounds, projections, loose material, dust, oil, grease, sealers. Determined to be structurally sound with a minimum five (5) day concrete cure period (unless otherwise directed by the SA-TWSI panel manufacturer) and that the surface is flat. As necessary, the flooring surface may be mechanically cleaned with a diamond cup grinder or shot blaster to remove any dirt or foreign material. However, a broom or leaf blower is usually adequate for cleaning of the substrate.

- E. Using Acetone, wipe the backside of the panel around the perimeter and along the internal cross pattern, to remove any dirt or dust particles from the area to receive the adhesive.
- F. Apply the adhesive to the back of the panel following the perimeter and internal cross pattern established by the panel manufacturer. Sufficient adhesive must be placed on the prescribed areas to have full coverage across the 51mm (2") width of the adhesive locator. It shall be applied to within 6.35mm (1/4") continuously around the perimeter edge of the panel. One (1) 296mL (10Oz.) cartridge of adhesive shall be applied to the back of each panel, sizes 610mm x 915mm (24" x 36") and up to 610mm x 1540mm (24" x 60"). Two (2) adhesive cartridges should be used for sizes 915mm x 1236mm (36" x 48") and 915mm x 1540mm (36" x 60").
- G. Working from the centre of the panel outwards, proceed to drill and install all fasteners in the panel's moulded recesses. By standing with both feet applying pressure around the moulded recess provided in the panel, drill holes true and straight to a depth of 51mm x 6.35mm (2" x 1/4") using the recommended 6.35mm (1/4") appropriate drill bit for the flooring surface. As necessary, additional countersink holes may be added to the SA-TWSI panel by using a 5 point, 12.7mm (1/2") 82° countersink to create the required holes. Drill through the panel without the hammer option (on the drill) until the panel has been successfully penetrated. Once through the panel, switch to the hammer option (on the drill) and drill into the substrate. NOTE: Maintaining foot pressure on both sides of the hole while drilling prevents dust from accumulating between the panel and flooring, which can affect the panel being installed flush and may compromise installation integrity.
- H. Immediately after drilling each hole, before moving on to the next, and while still applying foot pressure, mechanically fasten panels to the flooring surface using nylon or leather-bound mallet to set the fasteners. Ensure the fastener has been placed to full depth in the dome, straight, and flush to the top of the dome. Drive the pin of the fastener with the mallet, taking care to avoid any inadvertent blows to the truncated dome or panel surface.
- I. Following the installation of the fasteners, the dust should be vacuumed, brushed or blown away from the panel's surface and an adjacent surface. Using Acetone on a rag, wipe the surface around the perimeter of the panel to ensure a clean, dry surface to receive perimeter sealant.
- J. Perimeter caulking sealant should be applied following the sealant manufacturer's recommendations.
- K. Tape all perimeter edges of the panel back 1mm (0.04") from the panel's perimeter edge and tape the adjacent concrete back 12mm (0.47") from the panel's perimeter edge to maintain a straight and even caulking line. Apply sealant around panel perimeter using care to work sealant into any void between the panel and flooring surface. Tool the perimeter caulking with a rounded plastic applicator or spatula to create a cove profile between the panel and adjacent surface. Remove the tape immediately after tooling the perimeter caulking sealant.
- L. Do not allow foot traffic on installed panels until the perimeter caulking sealant has cured sufficiently to avoid tracking. The curing time is weather dependent. Follow the adhesive manufacturer's temperature application recommendations. Adhesive or caulking on the surface of the panel can be removed with Acetone.
- M. A polyurethane sealant such as Chemlink M1, Sikaflex 1a or BASF NP1 shall be applied to the edge treatment for a watertight Tactile Walking Surface Indicator panel installation.

3.03 CLEANING AND PROTECTING

- A. Protect SA-TWSI Panels against damage during the construction period to comply with SA-TWSI Panels manufacturer's specifications.

- B. Protect SA-TWSI panels against damage from rolling loads following installation by covering with plywood or hardwood.
- D. If requested by the Project Manager, clean SA-TWSI Panels not more than Four (4) days before the date scheduled for inspection intended to establish the date of substantial completion in each area of the project. Clean SA-TWSI panel by the method specified by ADA Solutions, LLC.
- E. Comply with ADA Solutions, LLC. maintenance manual for cleaning and maintaining the panel surface. It is recommended to perform annual inspections for safety and panel integrity.

END OF SECTION
Updated 01/10/2020

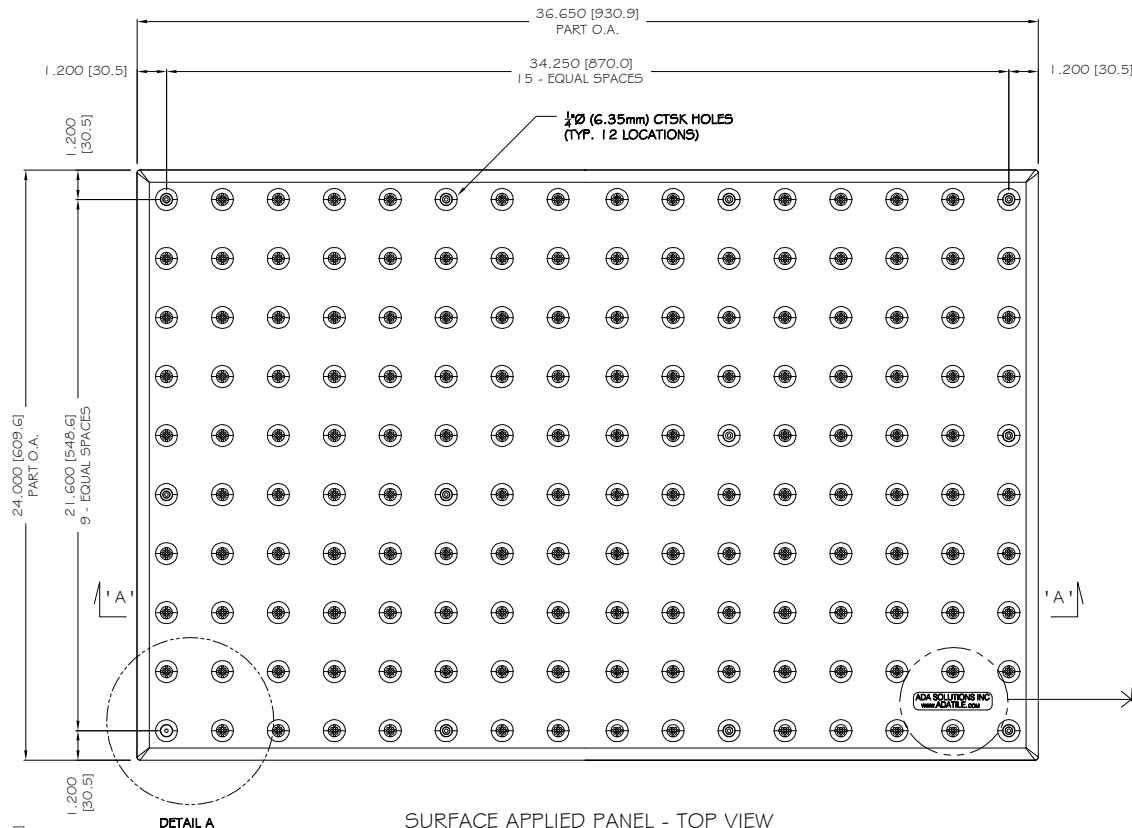

SURFACE APPLIED PANEL - TOP VIEW

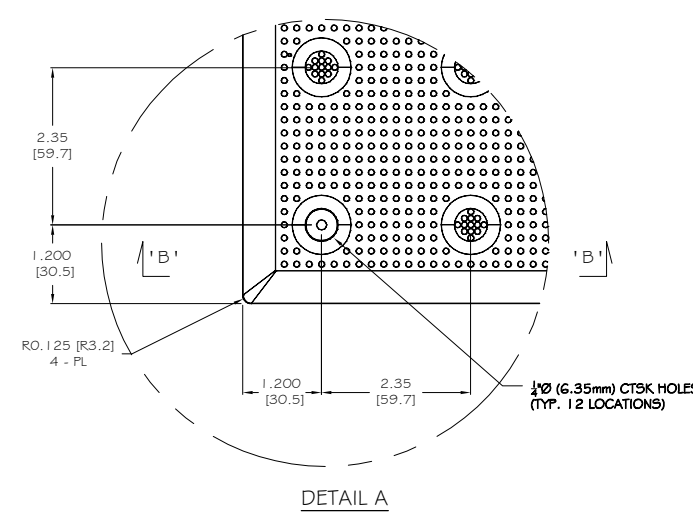

DETAIL A

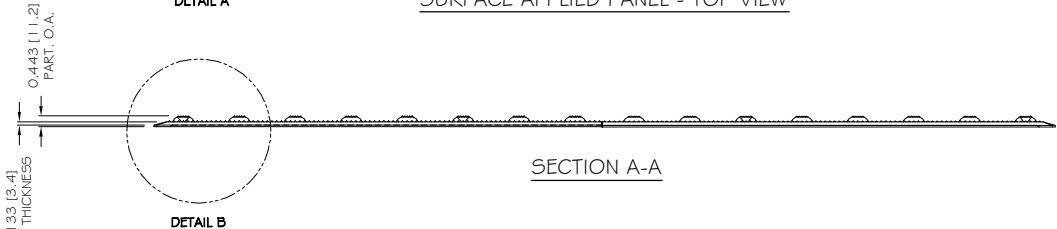
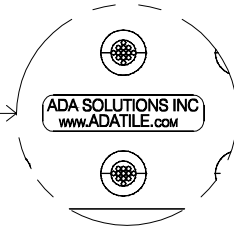

SECTION A-A

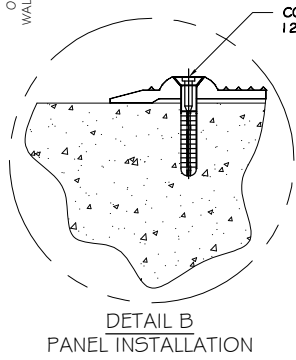

**DETAIL B
PANEL INSTALLATION**

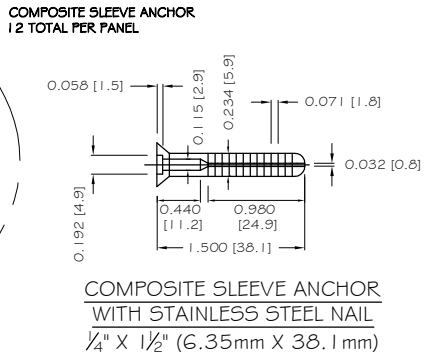

**COMPOSITE SLEEVE ANCHOR
WITH STAINLESS STEEL NAIL
1/4" X 1 1/2" (6.35mm X 38.1mm)**

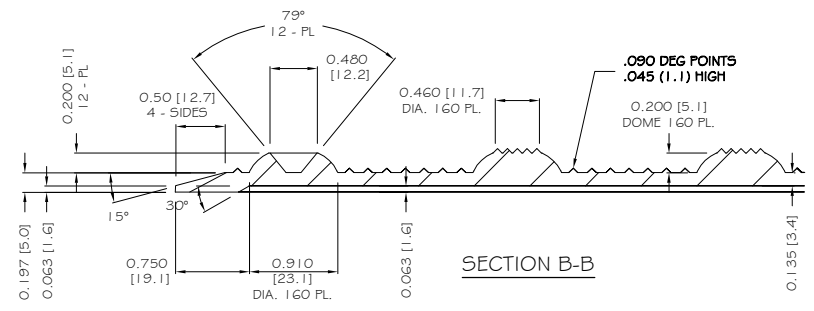

SECTION B-B

ALL DIMENSIONS NOMINAL PRIMARY DIMENSION INCHES mm IN PARENTHESES	
TRADE TACTILE WARNING SURFACE	PART NO. 2436IDRET2_
MATERIAL SMC COMPOSITE	
PROJECT SURFACE APPLIED TACTILE WARNING SURFACE PANEL 12-ANCHOR LOCATIONS 2.35" (59.7MM) IN LINE TRUNCATED DOME PART SIZE: 24" x 36" (610MM X 914MM) PLANS AND DETAILS	
DRAWING NO. ADA-SA2436_2	DATE 06-16-17
 ADA SOLUTIONS, INC. DETECTABLE WARNING SURFACES FOR PEDESTRIAN CROSSINGS WWW.ADATILE.COM PHONE: (800)372-0519 EMAIL: INFO@ADATILE.COM	

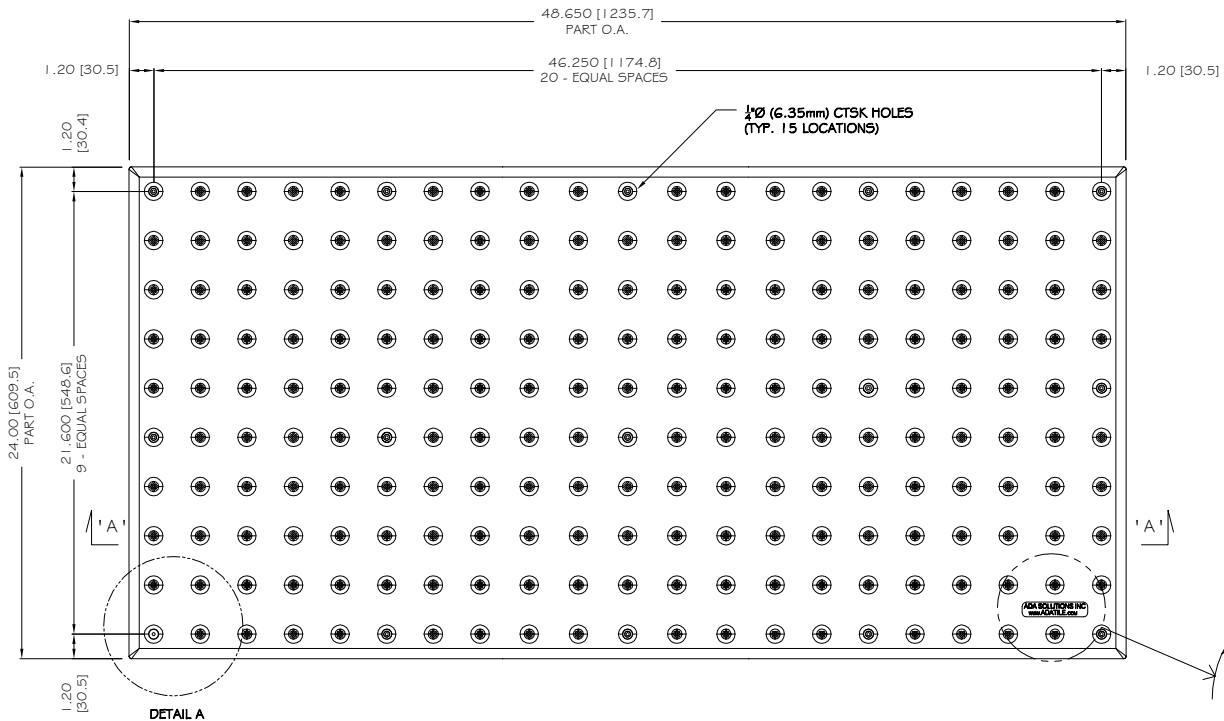

SURFACE APPLIED PANEL - TOP VIEW

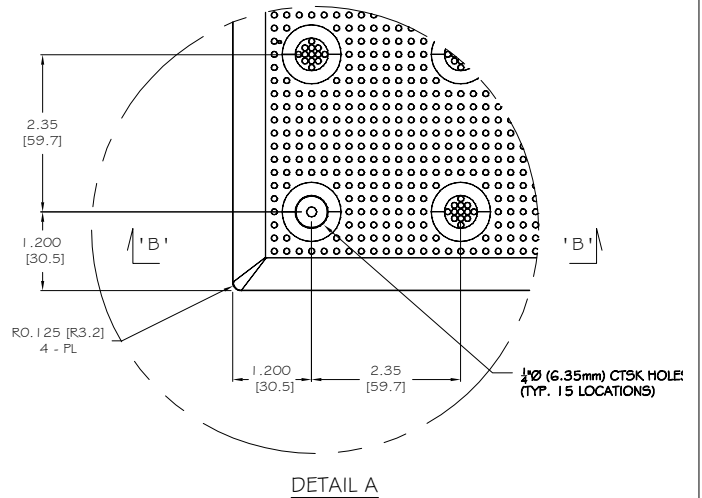

DETAIL A

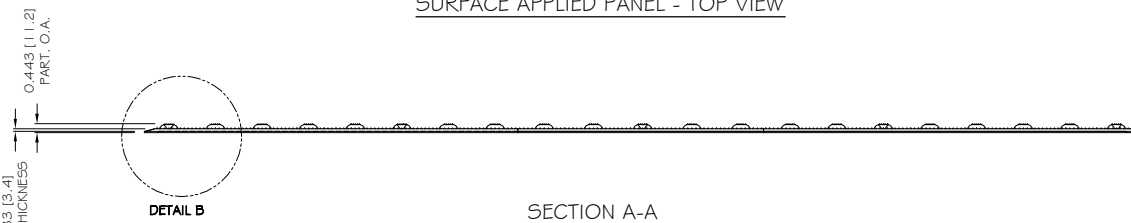
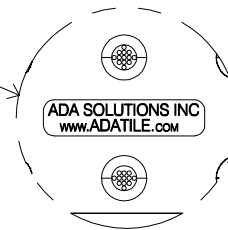

SECTION A-A

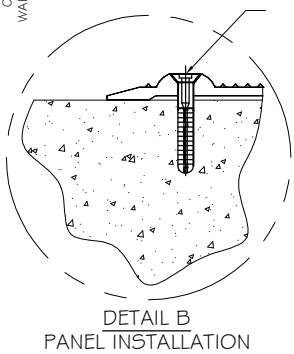

DETAIL B
PANEL INSTALLATION

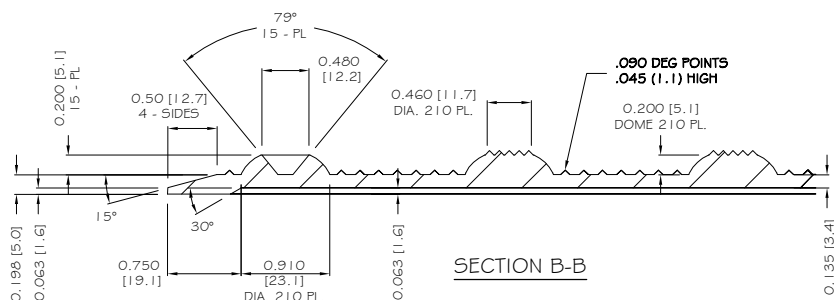
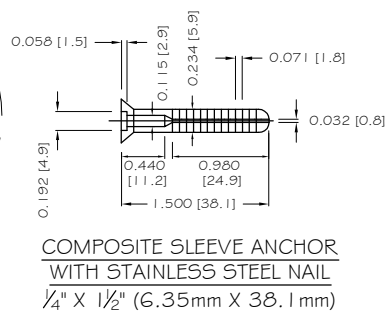

SECTION B-B

ALL DIMENSIONS NOMINAL PRIMARY DIMENSION INCHES mm IN PARENTHESES	
TRADE TACTILE WARNING SURFACE	PART NO. 2448IDRET2_
MATERIAL SMC COMPOSITE	
PROJECT SURFACE APPLIED TACTILE WARNING SURFACE PANEL 15-ANCHOR LOCATIONS 2.35" (59.7MM) IN LINE TRUNCATED DOME PART SIZE: 24" x 48" (610MM X 1219MM) PLANS AND DETAILS	
DRAWING NO. ADA-SA2448_2	DATE 06-16-17
 WWW.ADATILE.COM PHONE: (800)372-0519 EMAIL: INFO@ADATILE.COM	

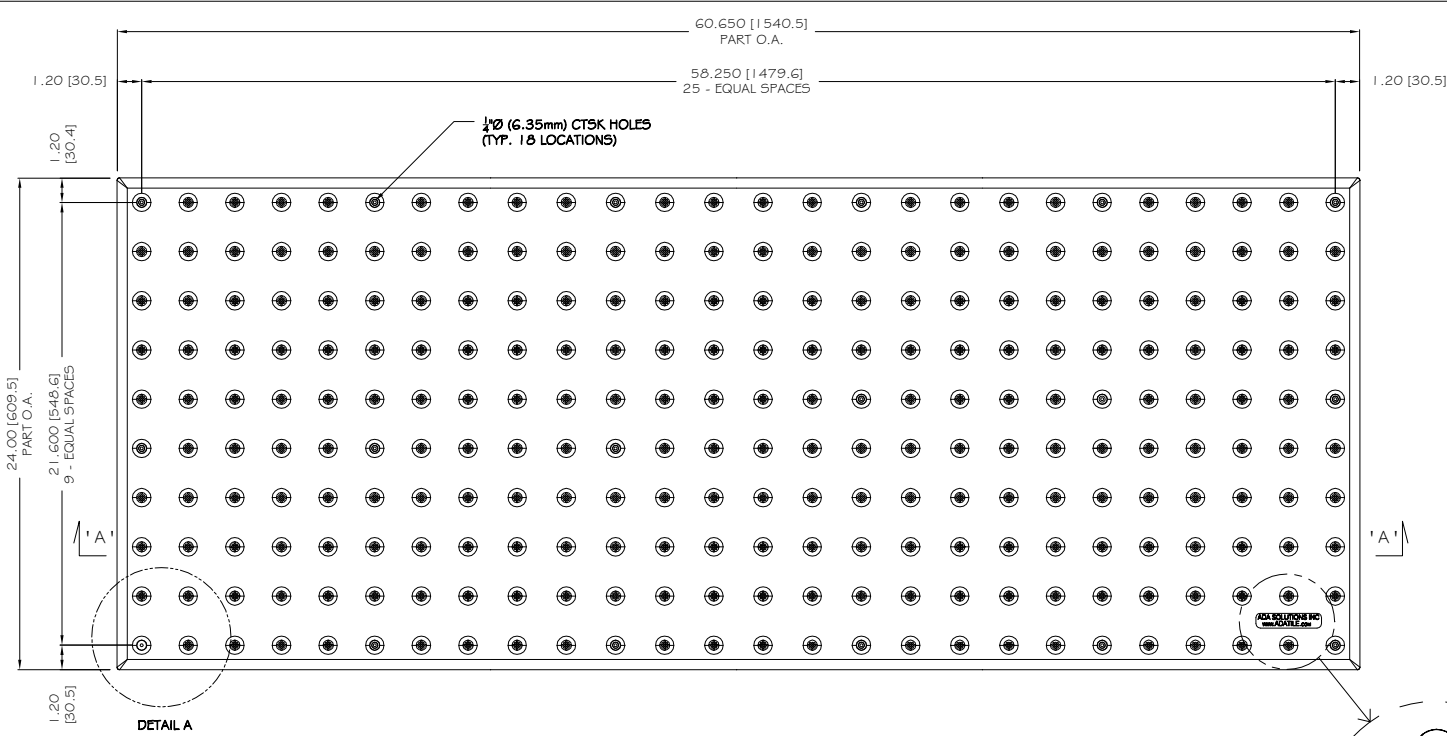

SURFACE APPLIED PANEL - TOP VIEW

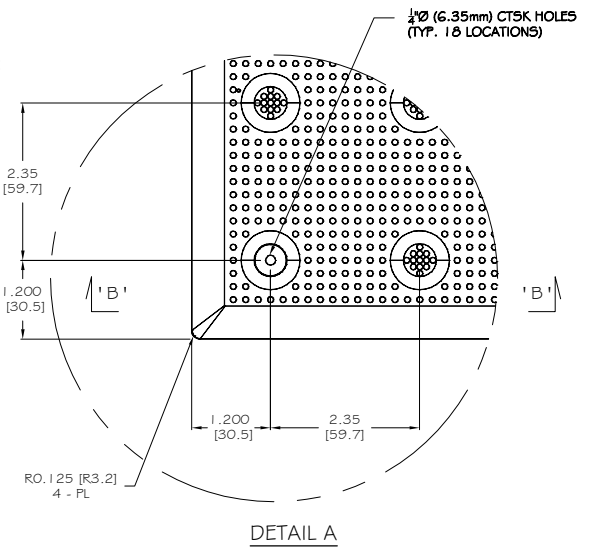

DETAIL A

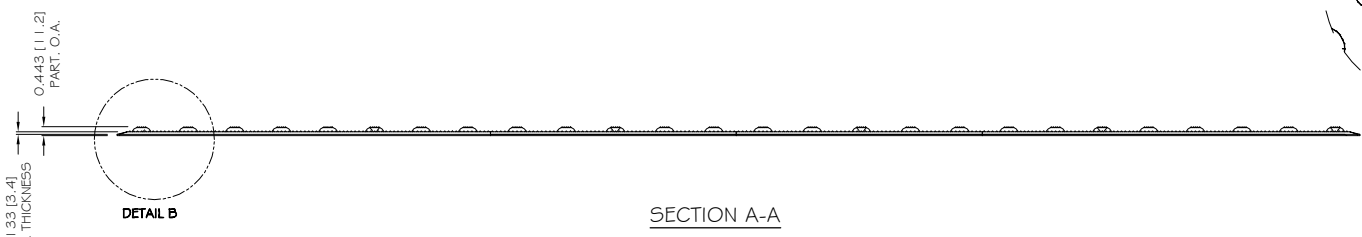

SECTION A-A

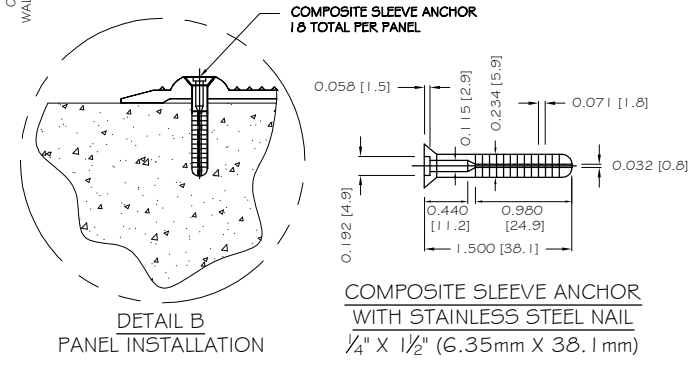

COMPOSITE SLEEVE ANCHOR WITH STAINLESS STEEL NAIL
 1/4" X 1/2" (6.35mm X 38.1mm)

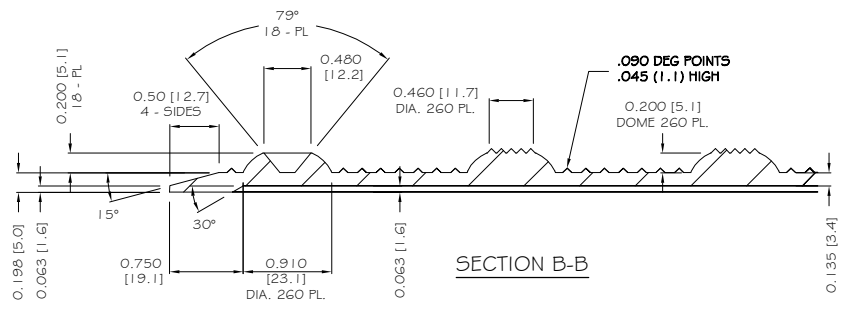

SECTION B-B

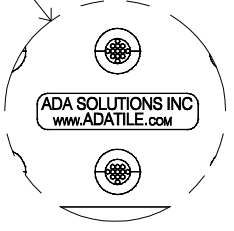

ALL DIMENSIONS NOMINAL PRIMARY DIMENSION INCHES mm IN PARENTHESES	
TRADE TACTILE WARNING SURFACE	PART NO. 2460IDRET2_
MATERIAL SMC COMPOSITE	
PROJECT SURFACE APPLIED TACTILE WARNING SURFACE PANEL 18-ANCHOR LOCATIONS 2.35" (59.7MM) IN LINE TRUNCATED DOME PART SIZE: 24" x 60" (610MM X 1524MM) PLANS AND DETAILS	
DRAWING NO. ADA-SA2460_2	DATE 06-16-17
 ADA SOLUTIONS, INC. DETECTABLE WARNING SURFACES FOR PEDESTRIAN CROSSINGS WWW.ADATILE.COM PHONE: (800)372-0519 EMAIL: INFO@ADATILE.COM	

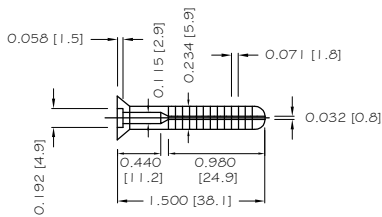
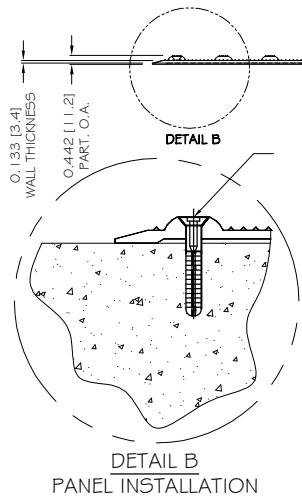
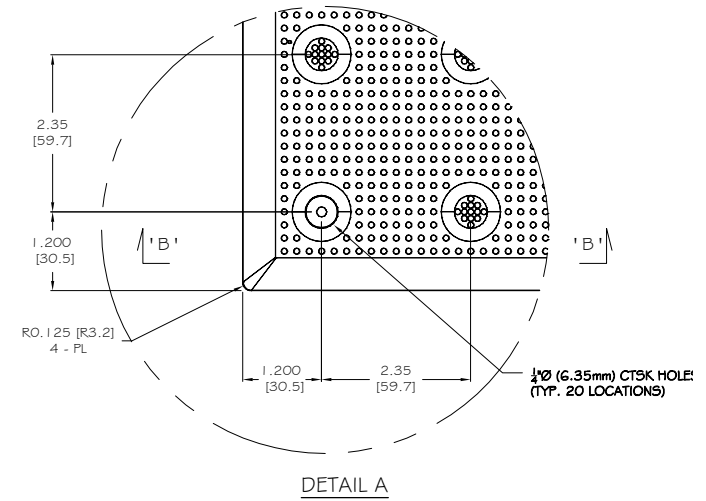
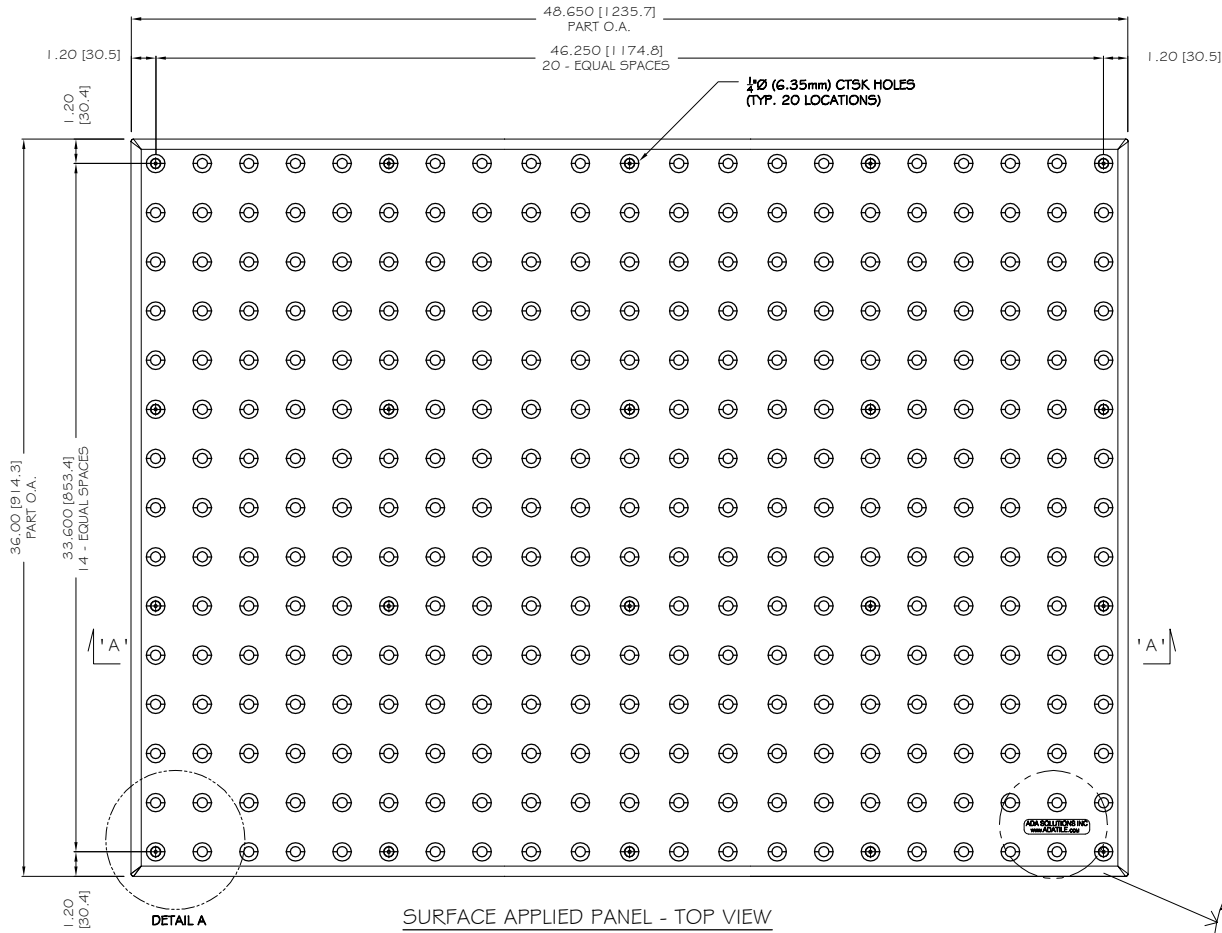

COMPOSITE SLEEVE ANCHOR
WITH STAINLESS STEEL NAIL
1/4" X 1 1/2" (6.35mm X 38.1mm)

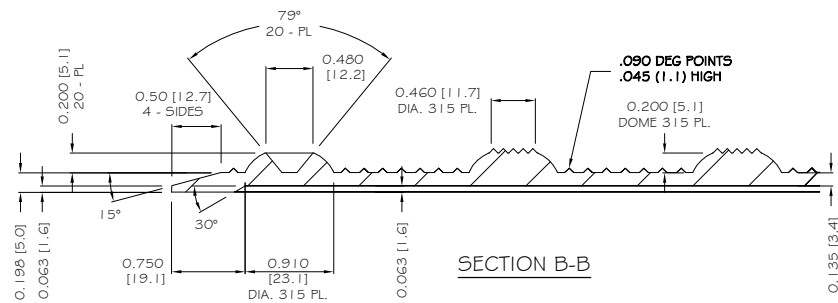

ADA SOLUTIONS INC
www.ADATILE.com

ADA SOLUTIONS INC
www.ADATILE.com

ALL DIMENSIONS NOMINAL
PRIMARY DIMENSION INCHES
mm IN PARENTHESES

TRADE TACTILE WARNING SURFACE	PART NO. 3648IDRET2_
MATERIAL SMC COMPOSITE	

PROJECT
SURFACE APPLIED TACTILE
WARNING SURFACE PANEL
20-ANCHOR LOCATIONS
2.35" (59.7MM) IN LINE TRUNCATED DOME
PART SIZE: 36" x 48" (914MM X 1219MM)
PLANS AND DETAILS

DRAWING NO. ADA-SA3648_2	DATE 06-16-17
-----------------------------	------------------



WWW.ADATILE.COM
PHONE: (800)372-0519
EMAIL: INFO@ADATILE.COM

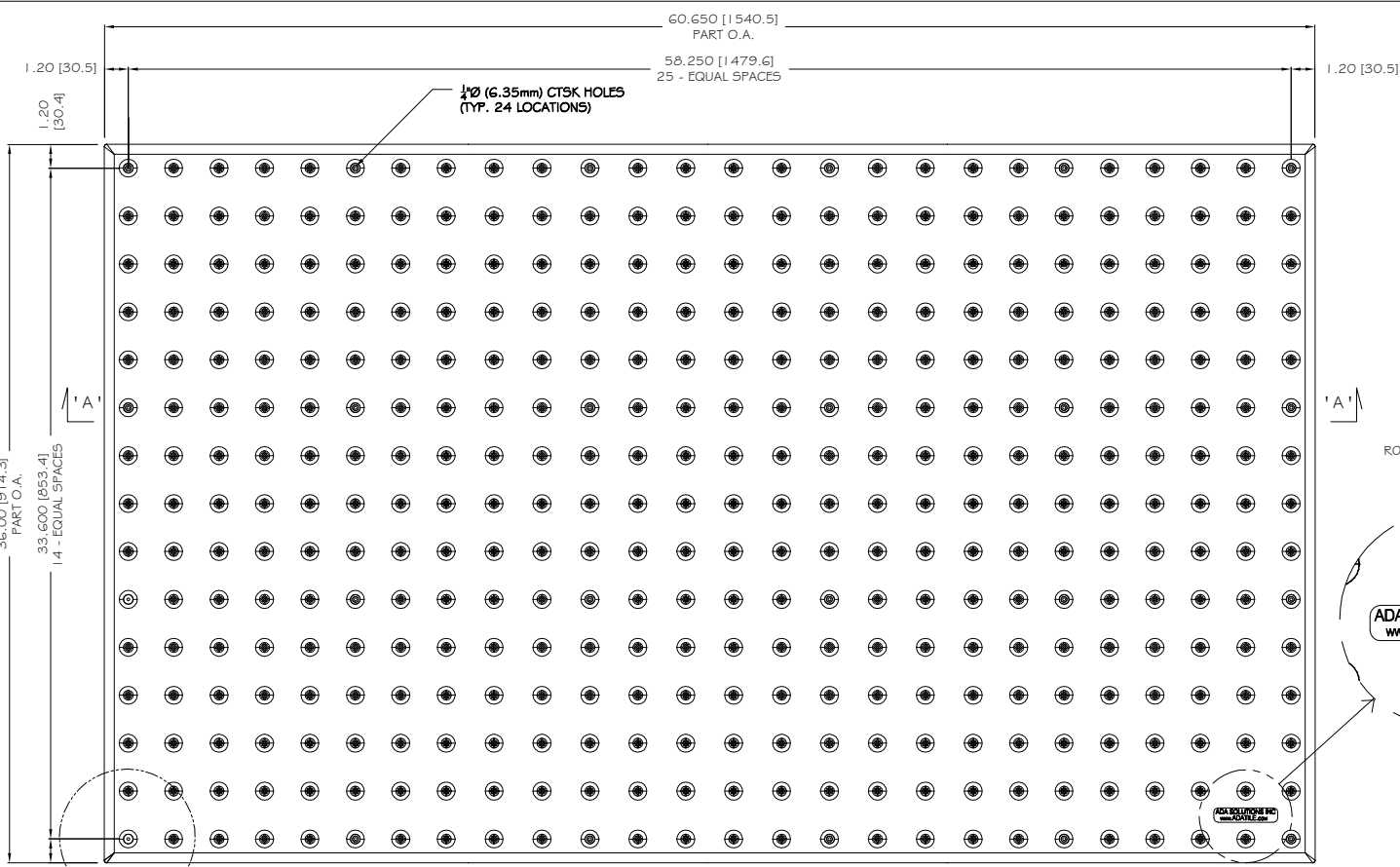

SURFACE APPLIED PANEL - TOP VIEW

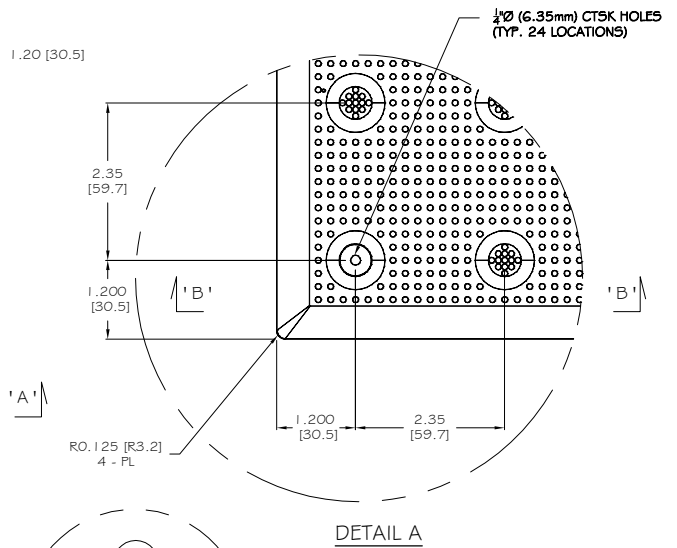

DETAIL A

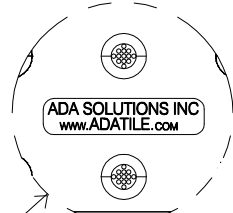

SECTION A-A

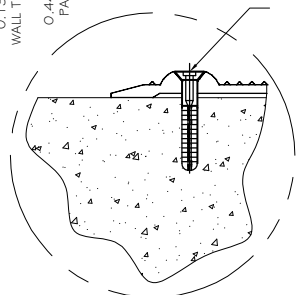

DETAIL B
PANEL INSTALLATION

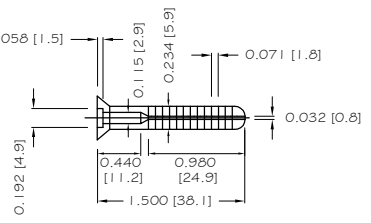

COMPOSITE SLEEVE ANCHOR
WITH STAINLESS STEEL NAIL
1/4" X 1/2" (6.35mm X 38.1mm)

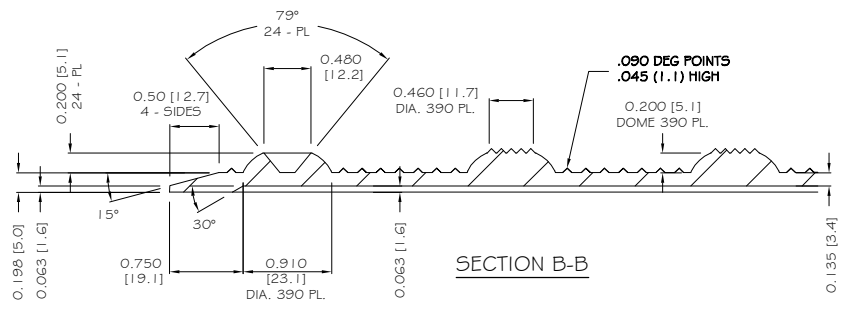

SECTION B-B

ALL DIMENSIONS NOMINAL
PRIMARY DIMENSION INCHES
mm IN PARENTHESES

TRADE TACTILE WARNING SURFACE	PART NO. 3660IDRET2_
MATERIAL SMC COMPOSITE	

PROJECT
 SURFACE APPLIED TACTILE
 WARNING SURFACE PANEL
 24-ANCHOR LOCATIONS
 2.35" (59.7MM) IN LINE TRUNCATED DOME
 PART SIZE: 36" x 60" (914MM X 1524MM)
 PLANS AND DETAILS

DRAWING NO. ADA-SA3660_2	DATE 06-16-17
-----------------------------	------------------



WWW.ADATILE.COM
 PHONE: (800)372-0519
 EMAIL: INFO@ADATILE.COM

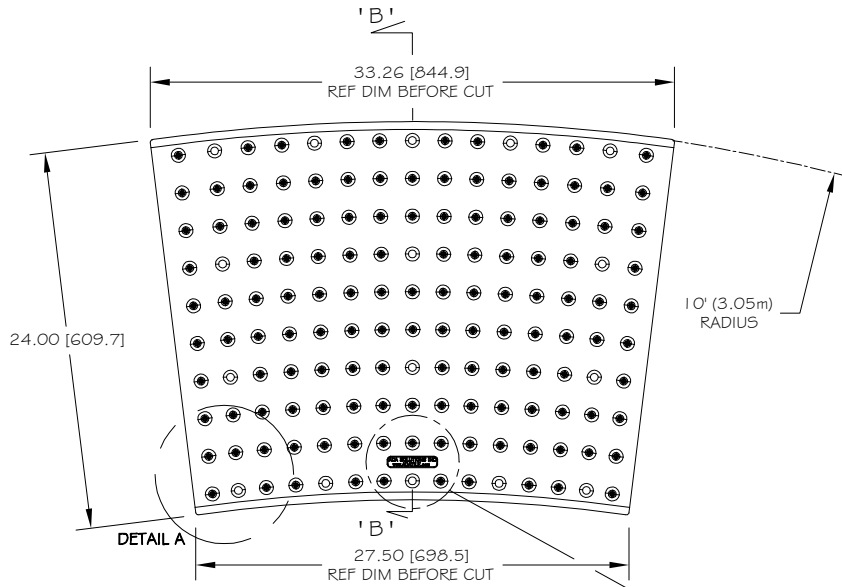

TOP VIEW

SIDE VIEW

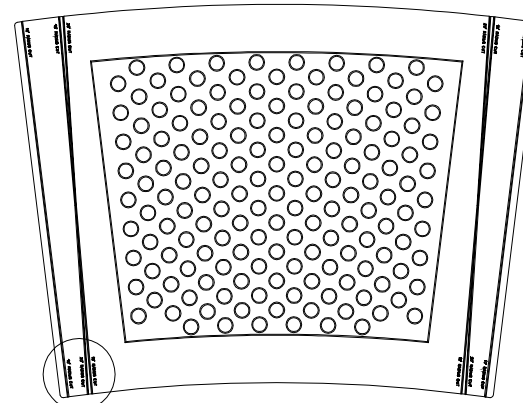

BOTTOM VIEW

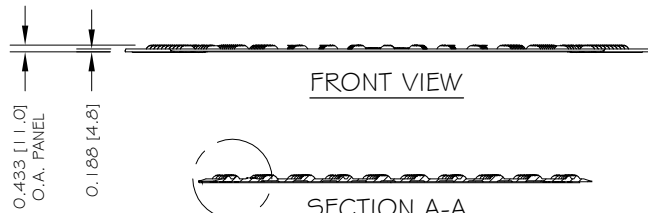

FRONT VIEW



SECTION A-A

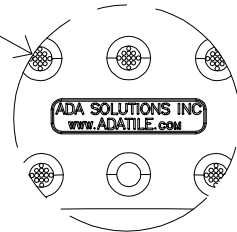

16 - ANCHOR LOCATIONS

LABELED RADIUS CUT LINES

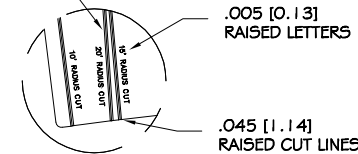

DETAIL C

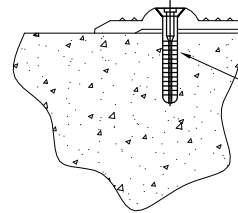

SECTION B-B
PANEL INSTALLATION

COMPOSITE SLEEVE ANCHOR
16 TOTAL PER PANEL

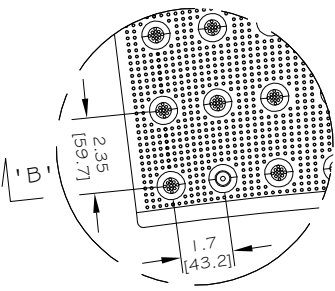

DETAIL A

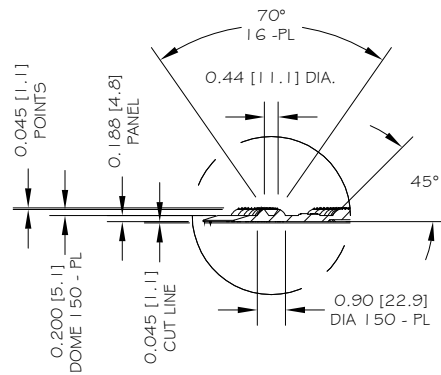

DETAIL B

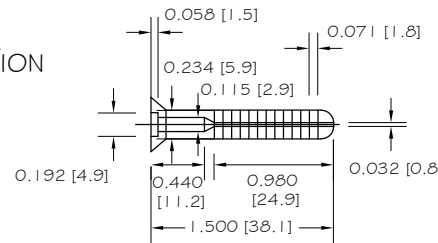

COMPOSITE SLEEVE ANCHOR
WITH STAINLESS STEEL NAIL
1/4" X 1 1/2" (6.35mm x 38.1mm)

Curb Radius	'A' Dimension	'B' Dimension
10'	2' - 8 ⁵ / ₁₆ "	2' - 2 ⁷ / ₁₆ "
15'	2' - 3 ⁵ / ₈ "	1' - 11 ⁷ / ₁₆ "
20'	2' - 3 ¹ / ₁₆ "	1' - 11 ¹⁵ / ₁₆ "

IMPERIAL UNIT CHART

Curb Radius (m)	'A' Dimension (mm)	'B' Dimension (mm)
3.05	821	671
4.57	702	595
6.10	687	608

METRIC UNIT CHART

ALL DIMENSIONS NOMINAL
PRIMARY DIMENSION INCHES
mm IN PARENTHESES

U.S. PATENT #9,365,984

TRADE TACTILE WARNING SURFACE	PART NO. 24RADRET_
MATERIAL SMC COMPOSITE	

PROJECT
SURFACE APPLIED TACTILE
WARNING SURFACE PANEL
16-ANCHOR LOCATIONS
2.350" (59.7mm) IN LINE TRUNCATED DOME
PART SIZE 24" (610mm) x 10' (3.05m),
15' (4.57m), 20' (6.10m) RADIAL
PLANS AND DETAILS

DRAWING NO. ADA-SA24RAD	DATE 06-16-17
----------------------------	------------------



WWW.ADATILE.COM
PHONE: (800)372-0519
EMAIL: INFO@ADATILE.COM

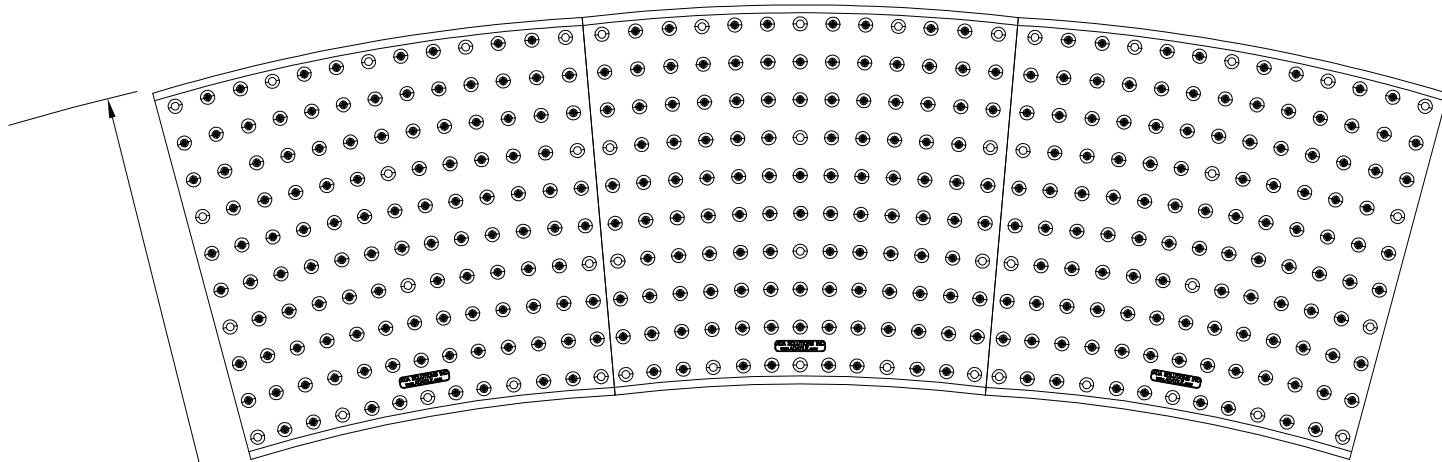

TOP VIEW OF PANEL LAYOUT IN A 15' (4.57m) RADIUS

R15' [R4.57m]

ALL DIMENSIONS NOMINAL PRIMARY DIMENSION INCHES mm IN PARENTHESES U.S. PATENT #9,365,984	
TRADE TACTILE WARNING SURFACE	PART NO. 24RADRET_
MATERIAL SMC COMPOSITE	
PROJECT SURFACE APPLIED TACTILE WARNING SURFACE PANEL LAYOUT 2.350" (59.7mm) IN LINE TRUNCATED DOME PART SIZE 24" (610mm) x 15' (4.57m) RADIAL	
DRAWING NO. ADA-SA24RADLAY	DATE 06-16-17
 ADA SOLUTIONS, INC. DETECTABLE WARNING SURFACES FOR PEDESTRIAN CROSSINGS WWW.ADATILE.COM PHONE: (800)372-0519 EMAIL: INFO@ADATILE.COM	



Composite Tactile Walking Surface Indicator Products

MAINTENANCE GUIDELINES:

1. ADA Composite Tactile Walking Surface Indicator Products:
 - A. [Surface Applied \(SA\)](#) TWSI Panels
 - B. [Cast-In-Place \(CIP\)](#) Permanently Embedded Composite Shell TWSI Panels
 - C. [Cast-In-Place Replaceable \(CIPR\) Wet Set](#) TWSI Panels
2. Cleaning of ADA Composite Tactile Walking Surface Indicator Products:
 - A. All Composite TWSI Products can be periodically pressure washed as required for cleanliness.
 - B. Keep water pressure nozzle at least 152mm (6") above the surface to be cleaned.
 - C. Any standard industrial cleaning solution can be used to clean the TWSI products.
 - D. Gum, Asphalt, and similar contaminants: Carefully scrape material off TWSI Products. A solvent such as acetone or xylene may be used to dissolve any residual contamination.
3. Fasteners: [Surface Applied](#) and [Cast-In-Place Replaceable \(Wet Set\)](#) Tactile Walking Surface Indicators Products only.
 - A. Inspect [Surface Applied](#) fasteners and [Cast-In-Place Replaceable \(Wet Set\)](#) caps to ensure they are securely installed and at appropriate finish grade.
 - B. Adjust fastener installation as necessary.
4. Sealant: [Surface Applied](#) TWSI Panels only.
 - A. Inspect sealant for integrity.
 - B. Replace any loose, damaged, or missing sealant.
 - C. Clean TWSI Panel and Substrate.
 - D. Install new sealant in accordance with sealant manufacturers recommendations (generally on a clean, dry substrate in a temperature range of 5°C to 35°C (41°F to 95°F)).

Thank you,

Brad D'Andrea
ADA Solutions, Inc.

**U.S. Patent # 7,779,581 + One or More U.S. Patents Pending

Tel: 800.372.0519 Fax: 978.262.9125
www.adatale.com



Wherever you go, there we are.®

Tactile Walking Surface Indicators (7) Year Product Warranty

Contract Number: (INSERT HERE)
Completion Date: (INSERT HERE)
Project Description: (INSERT HERE)
No. – Type of Panels: (INSERT HERE) | (INSERT HERE)
Project Installer: (INSERT HERE)
Project Owner: (INSERT HERE)

**Warranty becomes effective 24 hours after the date of installation*

ADA SOLUTIONS, INC. ("ADA Tactile Systems") warrants to the Project Owner and Project Purchaser that the Tactile Walking Surface Indicators ("TWSI") product supplied by ADA is free from defects in workmanship and material including deformation, discoloration, severe fading, and breakage for a period of Seven (7) Years from the date of acceptance of the Project. The warranty is valid only upon completion of the job, proper maintenance of the TWSI product, and payment in full to ADA.

EXCLUSIVE REMEDIES: ADA, at its cost, will repair or replace any defective material promptly reported during the warranty period to ADA. This warranty includes labour costs and the cost of removal of the TWSI product(s). Repair or replacements will be done on site.

All TWSI products manufactured by ADA Solutions, Inc. are hereby warranted to comply fully with all applicable AODA, CSA B651 (R2017), ISO 23599:2012, ISO 21542:2011, and NBC.

WARRANTY LIMITATIONS: ADA's warranty does not apply to conditions resulting from improper use, improper installation, external causes, acts of God, intentional misuse or abuse, neglected or improper annual maintenance, vandalism, modifications to the TWSI product, with the exception of the Owner's right to immediately eliminate an unsafe condition.

DISCLAIMER OF WARRANTY: The above warranty is the Owner's and Purchaser's exclusive warranty. No other warranty expressed or implied shall apply. ADA specifically makes no warranty of merchantability and/or fitness for a particular purpose. (In no event will ADA be liable for any damages, lost profit, consequential or economic damages) .

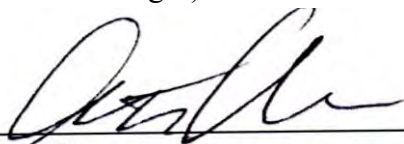

Scott Ober
 Vice President
 ADA Solutions, Inc.

323 Andover Street - Suite 3 ■ Wilmington, MA 01887
 Tel: 800.372.0519 Fax: 978.262.9125
www.adatale.com



Wherever you go, there we are.®

Certificate of Compliance

Contract Number: (INSERT HERE) _____

Date: (INSERT HERE) _____

Project Description: (INSERT HERE) _____

Installer: (INSERT HERE) _____

Owner: (INSERT HERE) _____

MANUFACTURER: ADA Solutions, Inc.

SUBJECT: Tactile Walking Surface Indicators

PRODUCT: Fibreglass and carbon reinforced polyester based composite. Sheet moulded compound (SMC) Colour-fast and UV stable; Cast-in-Place Pavers, Cast-in-Place Replaceable and Cast-in-Place Radius Replaceable as well our line of Cast Iron TWSI products.

We certify that the above material(s) conform(s) with all Tactile Walking Surface Indicator requirements as specified by the:

- ISO 23599:2012 - Assistive Products for Blind and Vision-Impaired Persons - Tactile Walking Surface Indicators.
- ISO 21542:2011 - Building Construction - Accessibility and Usability of the Built Environment. CSA B651-12 (R 2017) - Accessible Design for the Built Environment.
- Accessibility For Ontarians With Disabilities Act (AODA), 2005 - O. Reg. 413/12: Integrated Accessibility Standards Regulation (IASR) 191/11 – Sections 80.25 to 80.29
- National Building Code of Canada

Please feel free to contact us with any questions or requests for additional information.

Sincerely,

Brad D'Andrea
ADA Solutions, Inc.
brad@adatile.com
O: (978) 262-9900
C: (978) 831-3060



ADA SOLUTIONS, INC.
DETECTABLE WARNING SURFACES

Colour Chart

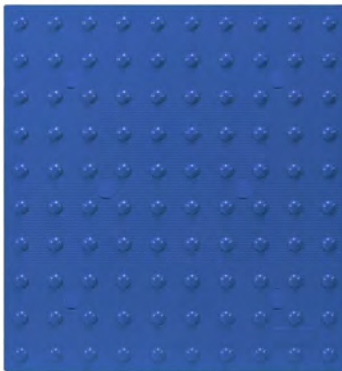

Safety Blue (B) Colour No. 15187

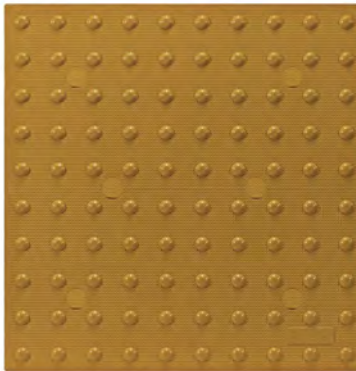

Seattle Yellow (SY) Colour No. 23594

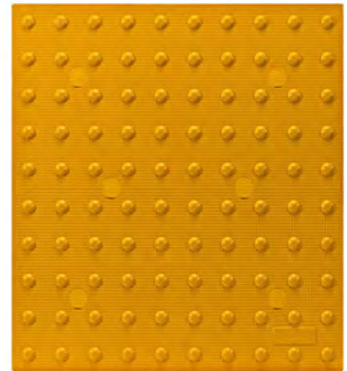

Federal Yellow (Y) Colour No. 33538

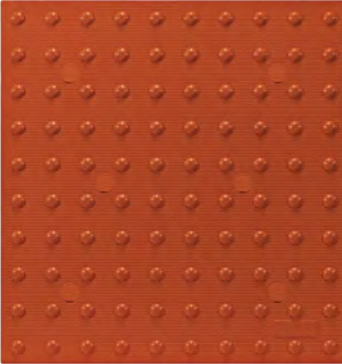

Clay Red (CR) Colour No. 22144

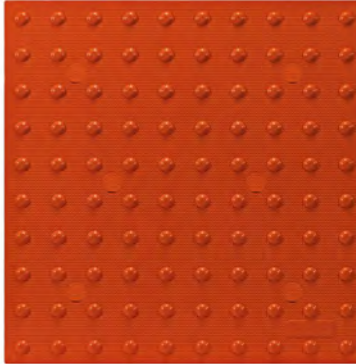

Brick Red (R) Colour No. 20109

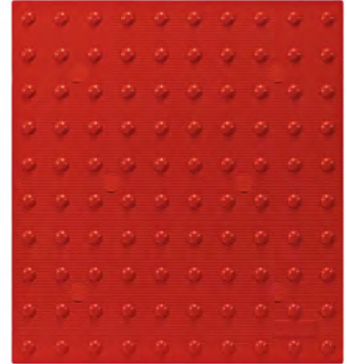

Safety Red (SR) Colour No. 31350

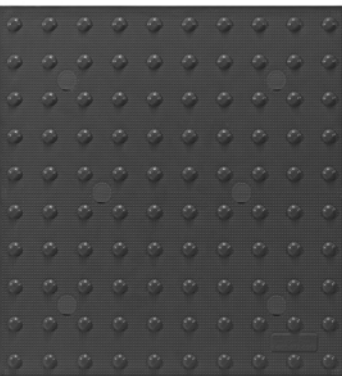

Dark Grey (G) Colour No. 36081

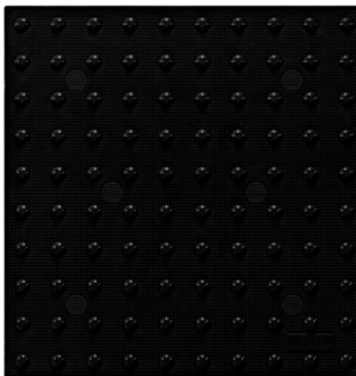

Black (B) Colour No. 37038

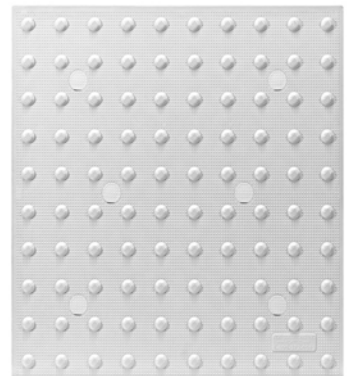

White (W) Colour No. 27925



Material Safety Data Sheet

Prepared By: Scott Ober

1. MATERIAL IDENTIFICATION

Product Name: Reinforced Molding Compound

Chemical Family: Polyester/Vinyl Ester

Chemical Formula: Proprietary

Material Use: Sheet Molding Compound

Manufacturer: ADA Solutions, Inc.

2. INGREDIENTS

Hazardous Ingredients	Approximate Concentration %	CAS No. or UN No.	Exposure Limits
Organic Peroxide	0.1 – 1.5%	CAS#614-45-9	N/A
Carbon Black	0.01 – 0.05%	CAS#1333-86-4	N/A

3. PHYSICAL DATA

Appearance and Odor: Solid mass, no odor

Specific Gravity: 1.1 – 2.0

Freezing Point: N/A

Solubility in Water: N/A

% Volatile by Volume: N/A

Boiling Point: N/A

pH: N/A

4. FIRE AND EXPLOSION INFORMATION HEALTH HAZARD DATA

Flammability: Class A Rating

Means of Extinction: Water or Chemical Fire Extinguisher

Special Procedures: None

Explosion Data: None Known

Sensitivity Mech. N/A

Impact:

Hazardous Combustion: None Known

Auto Ignition Temp.: 490 Degrees C

Sensitivity to Static: N/A

5. HEALTH HAZARD DATA

Permissible Exposure: N/A for product (See section 2)

6. REACTIVITY DATA

Chemical Stability: Yes
Reactivity: N/A

7. SPILL OR LEAK PROCEDURES

Spill: None (Solid Mass Product)
Waste Disposal: Recycle or deposit in landfill in accordance with
Local, State & Federal Regulations.

8. PROTECTIVE EQUIPMENT TO BE USED

Protective Gloves: Wear resistant gloves
Eye Protection: Safety glasses when cutting tiles

9. LEGAL DISCLAIMER

The information contained in this data sheet is furnished in good faith and without warranty, representations, or inducement or license of any kind, except that it is accurate to the best of ADA Solutions, Inc.'s knowledge, or was obtained from sources believed by ADA Solutions, Inc. to be reliable. The accuracy, adequacy or completeness of health and safety precautions set forth herein cannot be guaranteed, and the buyer is solely responsible for ensuring that the product is used, handled, stored, and disposed of safely and in compliance with applicable federal, state and local laws. ADA Solutions, Inc. disclaims liability for loss, damage, or personal injury that arises from, or is in any way related to, use of the information contained in this data sheet.



Safety Data Sheet: Molded SMC Tactile Warning Surface and Wayfinding Products

According to Federal Register / Vol.77, No.58 / March 26, 2012 / Rules and Regulations

SECTION 1: Identification of the Substance / Mixture and of the Company / Undertaking

1.1 Product Identifier

Product Molded SMC (Sheet Molding Compound) Parts.

1.2 Relevant Identified Uses of the Substance or Mixture

Use: PROWAG, ADA/ABA, CBC-2013 compliant Tactile Warning Surface and Wayfinding Products to warn pedestrians of curb ramps, hazardous vehicular areas and vertical drop-offs such as platform edges.

1.2 Details of the Supplier of the Safety Data Sheet

Continental Structural Plastics	ADA Solutions, Inc.
255 Rex Boulevard	323 Andover Street – Suite 3
Auburn Hills, MI 48326	Wilmington, MA 01887
Telephone : (248) 823-5664 or (248) 237-7800	Telephone: (800) 372-0519 or (978) 262-9900

1.2 Emergency Telephone Number

Emergency Number 24 Hour Contact CHEMTREC 1-800-424-9300

SECTION 2 : Hazards Identification

2.1 Classification of the Substance or Mixture

GHS – US Classification None

2.2 Label Elements

GHS - US Labelling:

Hazard Pictograms (GHS-US)	None
Signal Word (GHS-US)	None
Hazard Statement (GHS-US)	None

Precautionary Statements (GHS-US)	P264 - Wash hands and face thoroughly after handling. P280 - Wear protective gloves and eye protection. P302+P352 - If on skin : wash with soap and water. P305+P351+P338 - If in eyes : rinse cautiously with water for several minutes. Remove contact lenses if present and continue rinsing. P501 - Dispose of contents in compliance with federal, state and local regulation.
-----------------------------------	---

2.3 Other Hazards

No Additional Information Available.



Safety Data Sheet: Molded SMC Tactile Warning Surface and Wayfinding Products

According to Federal Register / Vol.77, No.58 / March 26, 2012 / Rules and Regulations

SECTION 3 : Composition / Information on Ingredients

3.1 Substances

Not Applicable.

3.2 Components of Sheet Molding Compound

Ingredient Name	Product Identifier	GHS-US Classification
None	(CAS No.) : N/A	Not Classified

Sheet Molding Compound Molded Parts would be considered "articles" as defined under Section 29 CFR 1910.1200 (c). This Safety Data Sheet is prepared for dust generating processes (grinding, cutting, drilling, etc.) from the molded SMC parts.

SECTION 4 : First-Aid Measures

4.1 Description of First-Aid Measures

First-Aid Measures after Inhalation	Assure fresh air breathing. Allow the person to rest.
First-Aid Measures after Skin Contact	Do not rub affected area. Wash with plenty of soap and water. If skin irritation occurs, get medical advice / attention.
First-Aid Measures after Eye Contact	Rinse immediately with plenty of water. Obtain medical attention if pain blinking or redness persists. Direct contact with eyes is likely irritating.
First-Aid Measures after Ingestion	Rinse mouth. DO NOT induce vomiting. Seek emergency medical attention.

4.2 Most Important Symptoms and Effects, both Acute and Delayed

Symptoms / Injuries	None other than listed in sections below
Symptoms / Injuries after Inhalation	Shortness of breath
Symptoms / Injuries after Skin Contact	Causes skin irritation

4.3 Indication of any Immediate Medical Attention and Special Treatment Needed

No Additional Information Available.

SECTION 5 : Firefighting Measures

5.1 Extinguishing Media

Extinguishing Media Foam. Dry powder. Carbon dioxide. Water spray. Sand.

5.2 Special Hazards Arising from the Substance or Mixture

Fire Hazard	Not applicable
Explosion Hazard	Not applicable

5.3 Advice for Firefighters

Firefighting Instructions	Use water spray or fog for cooling containers. Exercise caution when fighting any fire. Avoid firefighting water to enter environment. In case of fire : evacuate area.
Precaution during Firefighting	Do not enter fire area without proper protective equipment, including respiratory protection.



Safety Data Sheet: Molded SMC Tactile Warning Surface and Wayfinding Products

According to Federal Register / Vol.77, No.58 / March 26, 2012 / Rules and Regulations

SECTION 6 : Accidental Release Measures

6.1 Personal Precautions, Protective Equipment and Emergency Procedures

General Measures Not Applicable

6.1.1 For Non-emergency Personnel

Emergency Procedures Not Applicable

6.1.2 For Emergency Responders

Protective Equipment Not Applicable

Emergency Procedures Ventilate area

6.2 Environmental Precautions

Precautionary Actions Not Applicable

6.3 Methods and Material for Containment and Clean-up

Methods for Cleaning Up On land; sweep, shovel or lift into suitable containers.

6.4 Reference to Other Sections

See Section 8. Exposure Controls and Personal Protection.

SECTION 7 : Handling and Storage

7.1 Precautions for Safe Handling

Precautions for Safe Handling Wash hands and other exposed areas with mild soap and water before eating, drinking, smoking or leaving work. Provide good ventilation in process area to prevent formation of dust. Keep away from sources of ignition - no smoking. Obtain special instructions before use. Wash hands and face thoroughly after handling.

7.2 Conditions for Safe Storage - Including any Incompatibilities

Storage Conditions Not Applicable

Incompatible Products Not Applicable

Incompatible Materials Not Applicable

Storage Area Not Applicable

7.3 Specific End Use(s)

Molded Fiberglass Reinforced Plastic Parts.

SECTION 8 : Exposure Controls / Personal Protection

8.1 Exposure Parameters / Control

SMC Dust (CAS No. N/A)

USA ACGIH ACGIH TWA (mg/m³) 10 mg/m³ Inhalable Dust

USA OSHA OSHA PEL (TWA) (mg/m³) 15 mg/m³ Total Dust



Safety Data Sheet: Molded SMC Tactile Warning Surface and Wayfinding Products

According to Federal Register / Vol.77, No.58 / March 26, 2012 / Rules and Regulations

SECTION 8 : Exposure Controls / Personal Protection (Continued)

8.2 Exposure Controls

Appropriate Engineering Controls	Ensure that eyewash stations and safety showers are close to the workstation location. Ensure exposure below occupational exposure limits. Proper ventilation required.
Personal Protective Equipment	Avoid all unnecessary exposure. Safety glasses and gloves.
Hand Protection	Wear protective gloves.
Eye Protection	Safety glasses or goggles.
Respiratory Protection	Wear approved mask when Necessary.

SECTION 9 : Physical and Chemical Properties

9.1 Information on Basic Physical and Chemical Properties

Physical State	Solid
Color	Various
Odor	None
Odor Threshold	Not Applicable
pH	Not Applicable
Relative Evaporation Rate (butyl Ac=1)	Not Applicable
Melting Point	Not Applicable
Freezing Point	Not Applicable
Boiling Point	Not Applicable
Flash Point	Not Applicable
Self Ignition Temperature	No Data Available
Decomposition Temperature	No Data Available
Flammability (Solid, Gas)	Not Applicable
Vapor Pressure	Not Applicable
Relative Vapor Density @ 20 deg. C	Not Applicable
Relative Density	Specific Gravity - (1.15 - 2.00)
Solubility	Insoluble in water
Viscosity (Kinematic)	Not Applicable
Viscosity (Dynamic)	Not Applicable
Explosive Properties	Not Applicable
Oxidizing Properties	No Data Available
Explosive Limits	Not Applicable

9.2 Other Information

No Additional Information Available.



Safety Data Sheet: Molded SMC Tactile Warning Surface and Wayfinding Products

According to Federal Register / Vol.77, No.58 / March 26, 2012 / Rules and Regulations

SECTION 10 : Physical and Chemical Properties

10.1 Reactivity

No reactivity hazard other than the effects described in sub sections below.

10.2 Chemical Stability

Stable

10.3 Possibility of Hazardous Reactions

Not Applicable

10.4 Conditions to Avoid

Not Applicable

10.5 Incompatible Materials

Not Applicable

10.6 Hazardous Decomposition Products

Not Applicable

SECTION 11 : Toxicological Information

11.1 Information on Toxicological Effects

Acute Toxicity	Not classified
Skin Corrosion / Irritation	May cause skin irritation.
Eye Damage / Irritation	May cause eye irritation.
Respiratory or Skin Sensitization	Not classified
Germ Cell Mutagenicity	Not classified based on available data, the classification criteria not met.
Carcinogenicity	Persistence and degradability
Reproductive Toxicity	Not classified based on available data, the classification criteria not met.
Specific Target Organ Toxicity (1-Expos.)	Not classified based on available data, the classification criteria not met.
Specific Target Organ Toxicity (Repeat)	Not classified based on available data, the classification criteria not met.
Aspiration Hazard	Not classified based on available data, the classification criteria not met.
Potential Adverse Human Health Effects	Not classified based on available data, the classification criteria not met.
Symptoms / Injuries after Inhalation	Possible shortness of breath.
Symptoms / Injuries after Skin Contact	May cause skin irritation.

SECTION 12 : Ecological Information

12.1 Toxicity

No additional information available.

12.2 Persistence and Degradability

Molded SMC Parts

Persistence and degradability Not applicable

12.3 Bio accumulative Potential

Molded SMC Parts

Bio accumulative potential Not applicable

12.4 Mobility in Soil

Not applicable

12.5 Other Adverse Effects

None known



Safety Data Sheet: Molded SMC Tactile Warning Surface and Wayfinding Products

According to Federal Register / Vol.77, No.58 / March 26, 2012 / Rules and Regulations

SECTION 13 : Disposal Considerations

13.1 Waste Disposal / Treatment Methods

Waste Disposal Recommendations Dispose of in a safe manner in accordance with local, state and federal regulations.

SECTION 14 : Transportation Information

**** THIS PRODUCT NOT REGULATED BY USDOT ****

14.1 UN Number

UN-No. (DOT) Not applicable

14.2 UN Proper Shipping Name

DOT Proper Shipping Name Not applicable

14.3 Additional Information

Other Information Not applicable

SECTION 15 : Regulatory Information

15.1 US Federal Regulations

Sheet Molding Compound

EPA TSCA Regulatory Flag Not applicable

SARA Section 311 / 312 Hazard Classes Not applicable

SARA Section 313 TRI - Emission Reporting

Not Applicable

Material			Material		

15.2 US Federal Regulations

CANADA

EU - Regulations

Classification According to Regulation (EC) No.1272 / 2008 [CLP]

Classification According to Directive 67 / 548 / EEC or 1999 / 45 / EC

15.2.2 National Regulations

No additional information available.

15.3 US State Regulations

Not regulated.



Safety Data Sheet: Molded SMC Tactile Warning Surface and Wayfinding Products

According to Federal Register / Vol.77, No.58 / March 26, 2012 / Rules and Regulations

SECTION 16 : Other Information

Date Prepared: January 27, 2016

HMIS Label – SMC	
0	FIRE HAZARD
1	HEALTH HAZARD
0	REACTIVITY
B	PERSONAL PROTECTION

SDC – US (GHS HazCom – 2012)

The information herein contained is given in good faith, but no warrants expressed or implied are made.