 SURFACE VEHICLE RECOMMENDED PRACTICE	SAE J1939-71 JAN2008	
	Issued	1994-08
	Revised	2008-01
		Superseding J1939-71 NOV2006
Vehicle Application Layer (Through February 2007)		

RATIONALE

New parameters and parameter groups are reviewed and discussed by the Subcommittee on a regular basis. This SAE Recommended Practice has been updated to reflect all changes and additions approved and balloted through February 2007.

FOREWORD

This series of SAE Recommended Practices has been developed by the Truck and Bus Control and Communications Network Subcommittee of the Truck and Bus Electrical and Electronics Committee. The objectives of the subcommittee are to develop information reports, recommended practices, and standards concerned with the requirements design and usage of devices that transmit electronic signals and control information among vehicle components. The usage of these documents is not limited to truck and bus applications; other applications may be accommodated with immediate support being provided for construction and agricultural equipment, and stationary power systems. These documents are intended as a guide toward standard practice and are subject to change so as to keep pace with experience and technical advances.

New parameters and parameter groups are reviewed and discussed by the Subcommittee on a regular basis. This documents reflects all changes and additions approved and balloted through February 2007.

1. SCOPE

As described in the parent document, SAE J1939, there is a minimum of seven documents required to fully define a complete version of this network. This particular SAE Recommended Practice, SAE J1939-71, describes an Application Layer for vehicle use.

SAE Technical Standards Board Rules provide that: "This report is published by SAE to advance the state of technical and engineering sciences. The use of this report is entirely voluntary, and its applicability and suitability for any particular use, including any patent infringement arising therefrom, is the sole responsibility of the user."

SAE reviews each technical report at least every five years at which time it may be reaffirmed, revised, or cancelled. SAE invites your written comments and suggestions.

Copyright © 2008 SAE International

All rights reserved. No part of this publication may be reproduced, stored in a retrieval system or transmitted, in any form or by any means, electronic, mechanical, photocopying, recording, or otherwise, without the prior written permission of SAE.

TO PLACE A DOCUMENT ORDER: **Tel: 877-606-7323 (inside USA and Canada)**
 Tel: 724-776-4970 (outside USA)
 Fax: 724-776-0790
 Email: CustomerService@sae.org
SAE WEB ADDRESS: **<http://www.sae.org>**

2. REFERENCES

2.1 Applicable Publications

General information regarding this series of recommended practices is found in SAE J1939. Unless otherwise specified, the latest issue of SAE publications shall apply.

2.1.1 SAE Publications

Available from SAE, 400 Commonwealth Drive, Warrendale, PA 15096-0001, Tel: 877-606-7323 (inside USA and Canada) or 724-776-4970 (outside USA), www.sae.org.

SAE J1349 Engine Power Test Code-Spark Ignition and Compression Ignition-Net Power Rating

SAE J1843 Accelerator Pedal Position Sensor for Use with Electronic Controls in Medium- and Heavy-Duty Diesel On-Highway Engines

SAE J1922 Powertrain Control Interface for Electronic Controls Used in Medium- and Heavy-Duty Diesel On-Highway Engines

SAE J1939 Recommended Practice for a Serial Control and Communication Vehicle Network

SAE J1939-21 Data Link Layer

2.1.2 ISO Publications

Available from ANSI, 11 West 42nd Street, New York, NY 10036-8002.

2.1.3 Other Publications

Patent EP000001386774B1, "Control Apparatus for Brakes of a Commercial Vehicle", Held by Knorr-Bremse Systeme, Germany, Date 8/1/2003, included with permission from the patent holder

3. DEFINITIONS

See SAE J1939 for terms and definitions that are not defined in this document.

4. ABBREVIATIONS

ACC	Adaptive Cruise Control or Autonomous Cruise Control
ATA	American Trucking Association
CTI	Central Tire Inflation
EBS	Electronic Braking System
FMS	Fleet Management System
Kp	Engine endspeed governor gain
ROP	Roll Over Prevention
VDC	Vehicle Dynamic (Stability) Control
VGT	Variable Geometry Turbocharger
VMRS	Vehicle Maintenance Reporting System

See SAE J1939 for additional abbreviations that may be used in this document.

5. TECHNICAL REQUIREMENTS

The Application Layer provides a means for application processes to access the OSI environment. This layer contains management functions and generally useful mechanisms to support applications.

5.1 General Guidelines

5.1.1 Signal Characterization

It is the intent of the SAE J1939 network to provide current data and signals from a source so that it may be used by other nodes. It is recommended that the time between physical data acquisition of a signal and the transmission of the data should not exceed two times the repetition rate defined for the data. Additional constraints may be defined for certain parameters (see also 5.1.7.2).

5.1.2 Message Format

The message format of SAE J1939 uses the parameter group number as the label for a group of parameters. Each of the parameters within the group can be expressed in ASCII, as scaled data defined by the ranges described in 5.1.4, or as function states consisting of two or more bits. Alphanumeric data will be transmitted with the most significant byte first. Unless otherwise specified, alphanumeric characters will conform to the ISO Latin 1 ASCII character set as shown in section 5.1.3. Other parameters consisting of 2 or more data bytes shall be transmitted least significant byte first.

The type of data shall also be identified for each parameter. Data may be either status or measured. Status specifies the present state of a multi-state parameter or function as a result of action taken by the transmitting node. This action is the result of a calculation which uses local and/or network "measured" and/or "status" information. Note that specific confirmation of this action is not necessarily assured. For instance, the status may indicate that a solenoid has been activated, yet no measurement may have been taken to ensure the solenoid accomplished its function. Examples of status-type data are: engine brakes are enabled, PTO speed control is active, cruise control is active, the cruise control is in the "set" state of operation (as opposed to a measured indication that the "set" switch contacts are closed), fault codes, torque/speed control override modes, desired speed/speed limit, engine torque mode, engine's desired operating speed, engine's operating speed asymmetry adjustment, etc.

Measured data conveys the current value of a parameter as measured or observed by the transmitting node to determine the condition of the defined parameter. Examples of measured-type data are: boost pressure, ignition on/off, cruise set switch activated, maximum cruise speed, cruise set speed, engine speed, percent load at current speed, etc.

A device shall not receive SPN data from the network segment and retransmit that same SPN data using the same SPN back onto the same network segment.

5.1.3 ISO Latin 1 Character Set

Horizontal boldface characters are the single hexadecimal digit representing the lower nibble of the single byte code for the character. Vertical boldface characters are the single hexadecimal digit representing the upper nibble of the single byte code for the character.

	0	1	2	3	4	5	6	7	8	9	A	B	C	D	E	F
0	----- should not be displayed -----															
1	----- should not be displayed -----															
2	space	!	"	#	\$	%	&	'	()	*	+	,	-	.	/
3	0	1	2	3	4	5	6	7	8	9	:	;	<	=	>	?
4	@	A	B	C	D	E	F	G	H	I	J	K	L	M	N	O
5	P	Q	R	S	T	U	V	W	X	Y	Z	[\]	^	_
6	`	a	b	c	d	e	f	g	h	i	j	k	l	m	n	o
7	p	q	r	s	t	u	v	w	x	y	z	{		}	~	nil
8	----- should not be displayed -----															
9	----- should not be displayed -----															
A	nil	ı	ç	£	¤	¥		\$	¨	©	ª	«	□	~	®	□
B	□	±	²	³	´	µ	¶	·	¸	¹	º	»	¼	½	¾	¿
C	À	Á	Â	Ã	Ä	Å	Æ	Ç	È	É	Ê	Ë	Ì	Í	Î	Ï
D	Ð	Ñ	Ò	Ó	Ô	Õ	Ö	□	Ø	Ù	Ú	Û	Ü	Ý	Þ	ß
E	à	á	â	ã	ä	å	æ	ç	è	é	ê	ë	ì	í	î	ï
F	ð	ñ	ò	ó	ô	õ	ö	□	ø	ù	ú	û	ü	ý	þ	ÿ

5.1.4 Parameter Ranges

Table 1 defines the ranges used to determine the validity of a transmitted signal. Table 2 defines the ranges used to denote the state of a discrete parameter and Table 3 defines the ranges used to denote the state of a control mode command. The values in the range “error indicator” provide a means for a module to immediately indicate that valid parametric data is not currently available due to some type of error in the sensor, sub-system, or module.

The values in the range “not available” provide a means for a module to transmit a message which contains a parameter that is not available or not supported in that module. The values in the range “not requested” provide a means for a device to transmit a command message and identify those parameters where no response is expected from the receiving device.

If a component failure prevents the transmission of valid data for a parameter, the error indicator as described in Tables 1 and 2 should be used in place of that parameter’s data. However, if the measured or calculated data has yielded a value that is valid yet exceeds the defined parameter range, the error indicator should not be used. The data should be transmitted using the appropriate minimum or maximum parameter value.

5.1.5 Assignment of Ranges to New Parameters

This section is intended to define a set of recommended SLOTS (Scaling, Limit, Offset, and Transfer Function) which can be used when parameters are added to J1939. This permits data consistency to be maintained as much as possible between parameters of a given type (temperature, pressure, speed, etc.). Each SLOT is intended to provide a range and resolution suitable for most parameters within a given type. When necessary, a different scaling factor or offset can be used. All SLOTS should be based on a power of 2 scaling from another SLOT. This will minimize the math required for any internal scaling and reduce the opportunity for misinterpreted values. Offsets should be selected preferably on the following basis:

- a. Offset = 0, or
- b. Offset = 50% (equal \pm range)

Appendix A defines the recommended SLOTS to be used when ranges are assigned to new parameters.

(R) Unless otherwise specified, all pressure SLOTS are measured as gage pressure.

TABLE 1 - TRANSMITTED SIGNAL RANGES

Range Name	1 byte	2 bytes	4 bytes	ASCII
Valid Signal	0 to 250 00 ₁₆ to FA ₁₆	0 to 64 255 0000 ₁₆ to FAFF ₁₆	0 to 4 211 081 215 00000000 ₁₆ to FFFFFFFF ₁₆	1 to 254 01 ₁₆ to FE ₁₆
Parameter specific indicator	251 FB ₁₆	64 256 to 64 511 FB00 ₁₆ to FBFF ₁₆	4 211 081 216 to 4 227 858 431 FBxxxxxx ₁₆	none
Reserved range for future indicator bits	252 to 253 FC ₁₆ to FD ₁₆	64 512 to 65 023 FC00 ₁₆ to FDFF ₁₆	4 227 858 432 to 4 261 412 863 FC000000 ₁₆ to FDFFFFFF ₁₆	none
Error indicator	254 FE ₁₆	65 024 to 65 279 FExx ₁₆	4 261 412 864 to 4 278 190 079 FExxxxxx ₁₆	0 00 ₁₆
Not available or not requested	255 FF ₁₆	65 280 to 65 535 FFxx ₁₆	4 278 190 080 to 4 294 967 294 FFxxxxxx ₁₆	255 FF ₁₆

TABLE 2 - TRANSMITTED VALUES FOR DISCRETE PARAMETERS (MEASURED)

Range Name	Transmitted Value
Disabled (off, passive, etc.)	00
Enabled (on, active, etc.)	01
Error indicator	10
Not available or not installed	11

TABLE 3 - TRANSMITTED VALUES FOR CONTROL COMMANDS (STATUS)

Range Name	Transmitted Value
Command to disable function (turn off, etc.)	00
Command to enable function (turn on, etc.)	01
Reserved	10
Don't care/take no action (leave function as is)	11

5.1.6 Adding Parameters to Groups

Several of the Parameter Groups contain bytes that are not defined and may be replaced with new parameters as appropriate. If existing parameter group definitions do not permit the inclusion of a new parameter, a new parameter group may be defined. Refer to SAE J1939 for additional definitions and abbreviations for instructions for adding new parameters to parameter groups and for requesting new parameter group numbers.

In general, parameters should be grouped into parameter groups as follows:

- a. By function (Oil, Coolant, Fuel, etc.) and not by type (temperature, pressure, speed, etc.)
- b. With similar update rates (to minimize unnecessary overhead)
- c. By common subsystem (the device likely to measure and send data)

5.1.7 Transmission Repetition Rates (Update Rates)

5.1.7.1 Definition of Transmission Repetition Rate

All transmission repetition rates defined in SAE J1939/71 are nominal rates. The actual transmission repetition rate on the network should be at this rate plus/minus the "typical" jitter which occurs in microcontroller based systems. The average rate should be the nominal value.

5.1.7.2 Transmission Repetition Rate for Engine Speed and Directly Associated Data (Crank Angle or Time Based Update Rates)

Some parameters may be calculated and/or updated based on engine crank angle rather than at a specific time interval. When this is the case the reference to a specific update rate is not accurate because this time will change based on the speed of the engine. The primary goal is to minimize the latency associated with sampling, calculating and transmitting the data without overburdening the network. There are many approaches to sampling the data to be converted and sent over the network. The two preferred approaches are: (a) Time-based sampling, calculating and transmission; and (b) A hybrid time-based and engine crank angle-based sampling, calculating and transmission where the number of crank angle degrees between updates is modified based on the current operating speed in order to maintain an update rate within an acceptable range (see Figure 1). Because there are multiple ways to acquire and transmit data onto the network the following guidelines have been defined for the engine speed and directly associated data.

1. At speeds above 500 rpm, the time from sampling to message transmission shall not exceed 12 ms. Systems that acquire engine speed information via period measurement inherently have less time delay at higher speeds. Above 1000 rpm, for instance, the time from sampling to message transmission shall range from 5 to 30 ms. Less time is required because the period measurement takes less time at higher speeds. How much time is saved depends on the number of crank angle degrees used to perform the period measurement.
2. "Normal" update rates:
 - a. Time based updates will occur every 20 ms.
 - b. Hybrid time based and engine crank angle based updates are shown in Figure 1

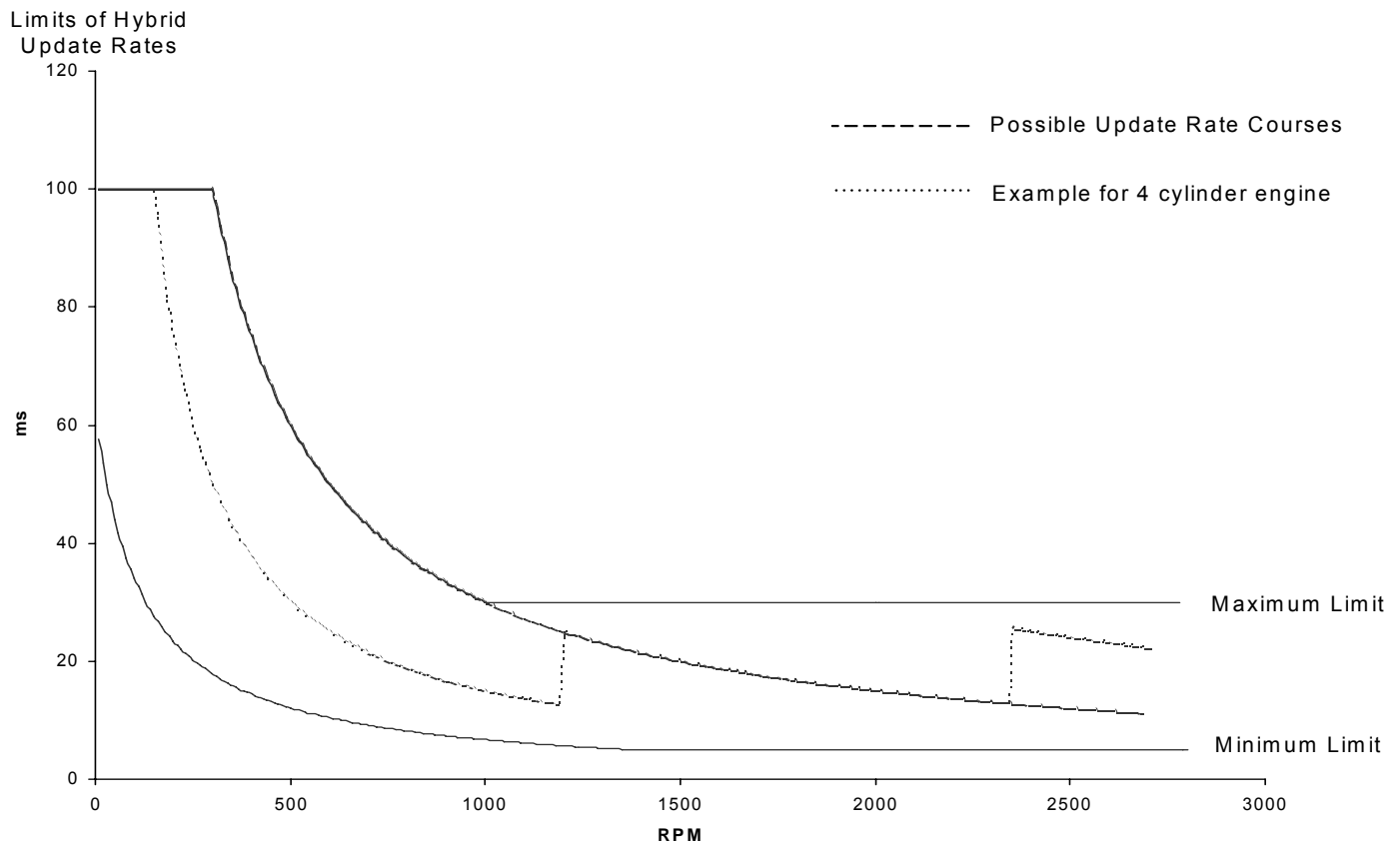

FIGURE 1 - LIMITS OF HYBRID UPDATE RATES

5.1.8 Naming Convention for Engine Parameters

When there are multiple instances of the same parameter on the same component (i.e., exhaust ports), the following naming convention will be used. While facing the engine from the flywheel housing, left bank (LB) parameters are assigned prior to the right bank (RB) parameters. Front parameters are assigned prior to the rear or back parameters (with the rear/back being the end containing the flywheel housing). For a six cylinder in-line engine, the position furthest from the flywheel will be identified as 1. For a 12 cylinder "V" engine, the position furthest from the flywheel on the left bank will be identified as 1, followed by the position next closest to the flywheel on the left bank. When only one parameter is required or available, the parameter denoted as number 1 should be used. (i.e., an engine having only one turbocharger would use Turbocharger 1 Compressor Inlet Temperature when broadcasting the temperature).

5.2 Parameter Definitions

This section provides a description of each parameter used for in the SAE J1939 network. The description includes data length, data type, resolution, range, and a tag (label) for reference.

After power on, a node should internally set the "availability bits" of received parameters as not available and operate with default values until valid data is received. When transmitting, undefined bytes should be sent as 255 (FF₁₆) and undefined bits should be sent as 1.

5.2.1 Control Parameters

5.2.1.1 Net Brake Torque (Power)

The measured torque (or power output) of a “fully equipped” engine. A fully equipped engine is an engine equipped with accessories necessary to perform its intended service. This includes, but is not restricted to, the basic engine, including fuel, oil, and cooling pumps, plus intake air system, exhaust system, cooling system, alternator, starter, emissions, and noise control. Accessories which are not necessary for the operation of the engine, but may be engine mounted, are not considered part of a fully equipped engine. These items include, but are not restricted to, power steering pump systems, vacuum pumps, and compressor systems for air conditioning, brakes, and suspensions. When these accessories are integral with the engine, the torque/power absorbed in an unloaded condition may be determined and added to the net brake torque. (Refer to SAE J1349.)

Net brake torque is calculated by subtracting friction torque from indicated torque for the purposes of this document.

5.2.1.2 Friction Torque

The torque required to drive the engine alone as “fully equipped.”

5.2.1.3 Indicated Torque

Indicated torque is the torque developed in the cylinders. It is defined as the sum of the net brake torque and friction torque.

5.3 Application Notes

5.3.1 Parameters with Multiple Sources

Each parameter received by a node for control purposes shall be configurable by the system integrator to identify the primary source of the data, as well as the secondary source, if applicable. It is to be expected that the system integrator configure each receiving device on a network identically. A secondary source of data is defined to be a device on the network that measures the data independently of the primary source of that data.

5.4 Conventions for SPN Start Position and Unused Bits in Message Definitions

The purpose of this section is to explain the convention in the PGN definition for identify the position of parameters within the PGN data field. This section explains how to determine the bits occupied by the parameter data and how to deal with the unspecified bits in the data field definition.

5.4.1 SPN Start Position and the Data Field Bits Occupied

The data field space occupied by a parameter is determined by the 'Starting Position' and 'Length' attributes listed next to the Parameter in the PGN definition. Each of the different Start Position conventions (indication techniques) used within the PGN definitions are explained in the tables below. The indication conventions are grouped according to whether the parameter data length is an integer number of bytes (1 byte, 2 byte, etc.), a fractional byte length (2 bits, 4 bits, 10 bits, etc.), or variable byte length.

Start Position	Length	Interpretation
R	Y byte	Indicates the parameter occupies the whole number of bytes starting with byte 'R'. Examples 3 1 byte: Parameter occupies byte 3 2 7 bytes: Parameter occupies bytes 2 through 8
R	8 bits	Indicates the parameter occupies all 8 bits of byte 'R'. Example 3 8 bits: Parameter occupies byte 3
R-S	Y bytes	Indicates the parameter occupies the 'Y' bytes from byte 'R' through byte 'S'. Examples 3-5 3 bytes: Parameter occupies bytes 3, 4, and 5 17-20 4 bytes: Parameter occupies bytes 17, 18, 19, and 20
R, S	Y bytes	Indicates the parameter occupies the 'Y' bytes from byte 'R' through byte 'S'. Example 3, 4 2 bytes: Parameter occupies bytes 3 and 4

TABLE 4 - CONVENTIONS FOR PARAMETERS WITH INTEGER BYTE LENGTH

Start Position	Length	Interpretation
R.x	Y bits	Indicates the parameter occupies 'Y' number of bits of byte 'R' starting at bit 'x' in byte 'R'. Examples 1.5 4 bits: Parameter occupies byte 1, bits 8-5 3.1 2 bits: Parameter occupies byte 3, bits 2-1
R.x-S	Y bits	Indicates the parameter occupies the most significant bits of byte 'R' from bit 'x' to bit 8 plus all whole bytes up to 'S'. Example (PGN 64982) 1.7-2 10 bits: Parameter occupies byte 1, bits 8-7 and all of byte 2 (where the least significant 2 bits are in byte 1 and the 8 most significant bits are in byte 2 (byte 2 bit 8 is most significant bit of the 10 bits))
R-S.x	Y bits	Indicates the parameter occupies all whole byte from 'R' up to 'S' and the remaining modulo-8 number of bits starting from bit 'x' in byte 'S'. Example (SPN 3169) 6, 7.1 12 bits: Parameter occupies byte 6 and byte 7, bits 4-1 (where 4 most significant bits at byte 7, bits 4-1 and least significant 8 bits in byte 6) Example (SPN 3036, J1939-73) 6-8.6 19 bits: Parameter occupies byte 6, 7 and byte 8, bits 8-6 (where 3 most significant bits at byte 8, bits 8-6 and least significant 8 bits in byte 6)

TABLE 5 - CONVENTIONS FOR PARAMETERS WITH FRACTIONAL BYTE LENGTHS

Start Position	Length	Interpretation
R-'N'	Variable – up to Y characters ("*" delimited)	Indicates the parameter starts at byte 'R' and continues through some variable number of bytes where the end is denoted by an asterisk character in the data stream. Example 2-N Variable - up to 200 characters ("*" delimited): Parameter starts at byte 2 and continues up to the asterisk character (at byte 202 at the highest)
R to 'N' 'N'+1 to 'P'	Variable – up to Y characters Variable – up to Y characters	Indicates the first parameter starts at byte 'R' and continues through some variable number of bytes to the end denoted by an asterisk. And indicates the second parameter starts at the first byte following the asterisk delimiter for the first parameter and continues through some variable number of bytes to the end denoted by an asterisk. Example (PGN 64958) 5 to A Variable - up to 100 characters: Parameter starts at byte 5 and continues up to the asterisk character (byte 105 at the highest) A+1 to B Variable - up to 100 characters: Parameter starts at first byte after the delimiter for the previous and continues up to the next asterisk character
'n'	Variable – up to Y characters ("*" delimited)	Indicates the parameter is the nth field and continues some variable number of bytes where the end is denoted by an asterisk character in the data stream. Example (PGN 64965) c Variable - up to 200 characters ("*" delimited): Parameter is the 3rd field and continues up to the asterisk character (200 bytes beyond start of 3rd field at the highest)
'n'	Y bytes	Indicates the parameter is sequentially field 'n' and occupies Y number of bytes from the point that the field starts. Example a 5 bytes:Parameter is the first field and consists of 5 bytes from the start of that field

TABLE 6 - CONVENTIONS FOR PARAMETERS WITH VARIABLE LENGTH AND FIELDS

5.4.2 Unspecified bits in the PGN Data Field Definition

The J1939-71 PGN Definitions only list the data field bits and bytes that have parameter assignments. Any bits of the PGN data field that are not assigned to a parameter are not shown in the PGN definition. The 'Data Length' attribute of the PGN definition specifies the byte length of the data field for the PGN.

Bits within this data field byte length that are not accounted for by the collection of parameters in the PGN are unspecified bits. When transmitted, the message data field for the transmitted PGN must be at least the minimum length specified by the 'Data Length' attribute. All unspecified bits within the transmitted message data length must be filled with a value of one (1). The unspecified bits are available for assignment to parameters at some future time.

5.4.2.1 Example using PGN 65213

The PGN Data Length and PGN data content for PGN 65213 are shown below. The 'Data Length' attribute for this PGN indicates the PGN has a message data field length of 8 bytes. Only 28 bits of the message data field have data assignments – byte 1, bits 4-1 of byte 2, byte 3 and byte 4. There are 36 unspecified bits in the message – bits 8-5 of byte 2 and bytes 5-8. When transmitted, the message data field for this PGN must be 8 bytes in length. The 36 unspecified bits must be filled each with a one (1) and the assigned 28 bits must be filled appropriately.

PGN 65213 Fan Drive – FD

Data Length:8

Start Position	Length	Parameter Name	SPN
1	1 byte	Estimated Percent Fan Speed	975
2.1	4 bits	Fan Drive State	977
3-4	2 bytes	Fan Speed	1639

Byte 1				Byte 2				Byte 3				Byte 4											
8	7	6	5	4	3	2	1	8	7	6	5	4	3	2	1	8	7	6	5	4	3	2	1
SPN 975				1	1	1	1	SPN 977				SPN 1639											

Byte 5				Byte 6				Byte 7				Byte 8											
8	7	6	5	4	3	2	1	8	7	6	5	4	3	2	1	8	7	6	5	4	3	2	1
1	1	1	1	1	1	1	1	1	1	1	1	1	1	1	1	1	1	1	1	1	1	1	1

TABLE 7 – EXAMPLE PGN 65213

6. NOTES

6.1 Marginal Indicia

The (R) is for the convenience of the user in locating areas where technical revisions have been made to the previous issue of the report. If the symbol is next to the report title, it indicates a complete revision of the report.

PREPARED BY THE SAE TRUCK AND BUS CONTROL AND COMMUNICATIONS NETWORK
SUBCOMMITTEE OF THE SAE TRUCK AND BUS ELECTRICAL AND ELECTRONICS COMMITTEE

APPENDIX A SLOTS

Slot Name	Slot Type	Units	Range	Offset	Length	Slot Identifier
Diagnostic						202
SAEac01	Acceleration	m/s ²	-15.687 to +15.687 m/s ²	-15.687 m/s ²	2 bytes	115
SAEac02	Acceleration	m/s ²	-12.5 to +12.5 m/s ²	-12.5 m/s ²	1 byte	140
SAEad01	Angle/Direction	deg	-210 to 211.1008122 deg	-210 deg	4 bytes	7
SAEad02	Angle/Direction	deg	-3276.8 to 3148.7 sec	-3,276.8 sec	2 bytes	10
SAEad03	Angle/Direction	deg	-31.374 to +31.374 rad	-31.374 rad	2 bytes	113
SAEad04	Angle/Direction	deg	-200 to 301.99 deg	-200 deg	2 bytes	8
SAEad05	Angle/Direction	deg	0 to 501.99 deg	0	2 bytes	9
SAEad06	Angle/Direction	deg	-125 to 125 deg	-125 deg	1 byte	11
SAEad07	Angle/Direction	deg	-125 to 125 deg	-125 deg	2 bytes	136
SAEad08	Angle/Direction	deg	-64 to 64.51 deg	-64	2 bytes	242
SAEad09	Angle/Direction	deg	-12.5 to 12.5 deg	-12.5 deg	1 byte	244
SAEad10	Angle/Direction	deg	-65 to 60 deg	-65 deg	1 byte	248
SAEat0001	ASCII, text	ASCII	0 to 255 per byte	0	1 byte	94
SAEat0002	ASCII, text	ASCII	0 to 255 per byte	0	2 bytes	131
SAEat0004	ASCII, text	ASCII	0 to 255 per byte	0	4 bytes	212
					Variable - up to 5 characters followed by an "***	
(R) SAEat0005	ASCII, text	ASCII	0 to 255 per byte	0	delimiter	109
(R) SAEat0005nd	ASCII, text (non-delimited)	ASCII	0 to 255 per byte	0	5 bytes	273
SAEat0007	ASCII, text	ASCII	0 to 255 per byte	0	7 bytes	110
SAEat0016	ASCII, text	ASCII	0 to 255 per byte	0	16 bytes	282
(R) SAEat0025	ASCII, text	ASCII	0 to 255 per byte	0	25 bytes	271
					Variable - up to 100 characters	
SAEat0100nd	ASCII, text (non-delimited)	ASCII	0 to 255 per byte	0		228
					Variable - up to 200 characters ("*** delimited)	
SAEat0200	ASCII, text	ASCII	0 to 255 per byte	0		108
					Variable - up to 200 characters	
SAEat0200nd	ASCII, text (non-delimited)	ASCII	0 to 255 per byte	0		258
SAEat1728	ASCII, text	ASCII	0 to 255 per byte	0	Variable ("*** delimited)	111
SAEba01	Brake Applications	brake appl	0 to 4,227,858,431 appl	0	4 bytes	81
SAEbm08	Bit mapped	bit-mapped	bit-mapped	0	8 bits	275
SAEbm16	Bit mapped	bit-mapped	bit-mapped	0	16 bits	276
SAEbm64	Bit mapped	bit-mapped	bit-mapped	0	64 bits	278
SAEbs01	Bit Field	bit	0 to 1	0	1 bit	86
SAEbs02	Bit Field	bit	0 to 3	0	2 bits	87
SAEbs03	Bit Field	bit	0 to 7	0	3 bits	88
SAEbs04	Bit Field	bit	0 to 15	0	4 bits	89
SAEbs05	Bit Field	bit	0 to 31	0	5 bits	90
SAEbs06	Bit Field	bit	0 to 63	0	6 bits	91
SAEbs07	Bit Field	bit	0 to 127	0	7 bits	92
SAEbs08	Bit Field	bit	0 to 255	0	8 bits	93
SAEbs11	Bit Field	bit	0 to 2047	0	11 bits	218
SAEbs12	Bit Field	bit	0 to 4095	0	12 bits	281
SAEbs21	Bit Field	bit	0 to 2097151	0	21 bits	217
SAEbs24	Bit Field	bit	0 to 16777215	0	24 bits	280
SAEbs32	Bit Field	bit	0 to 4294967296	0	32 bits	245
SAEby01	Number of bytes	bytes	0 to 250	0	1 byte	239
SAEca01	Capacity, Battery	mAhr	0 to 64255mAhr (64.255Ahr)	0	2 bytes	211
SAEcb01	Control byte	binary	0 to 255	0	1 byte	120
SAEcd01	Calendar, days	Days	0 to 62.5 days	0	1 byte	60
SAEcm01	Calendar, months	Months	0 to 250 months	0	1 byte	62
		microSiemens/mm	0 to 1250 microSiemens/mm	0	1 byte	255
SAEco01	Conductivity					
SAEct01	Count	count	-32 to 29 turns	-32 turns	6 bits	141
SAEct02	Count	count	0 to 250	0	1 byte	129

Slot Name	Slot Type	Units	Range	Offset	Length	Slot Identifier
SAEct03	Count	count	0 to 255	0	1 byte	133
SAEct04	Count	count	0 to 64,255 counts	0	2 bytes	12
SAEct05	Count	count	0 to 65,535 counts	0	2 bytes	208
SAEct06	Count	count	0 to 16,777,216 counts	0	3 bytes	207
SAEct07	Count	count	0 to 4,294,967,295 counts	0	4 bytes	209
SAEct08	Count	count	0 to 15	0	4 bits	220
SAEct09	Count	count	-125 to 125 counts	-125	1 byte	230
SAEct10	Count	count	0 to 31	0	5 bits	232
SAEct11	Count	count	0 to 4095	0	12 bits	233
SAEct12	Count	count	0 to 127	0	7 bits	260
SAEew01	Calendar, weeks	Weeks	-125 to 125 weeks	-125 weeks	1 byte	65
SAEcy01	Calendar, years	Years	1985 to 2235 years	1985 years	1 byte	66
SAEde01	Dielectricity		0 to 25.0	0	1 byte	139
SAEds02	Distance	m	-209.7152 to 211.3929215 m	-209.7152 m	4 bytes	142
SAEds03	Distance	m	-3,200 to 3,225.5 mm	-3,200 mm	2 bytes	13
SAEds04	Distance	m	0 to 6,425.5 mm (0 to 6.4255 m)	0	2 bytes	14
SAEds05	Distance	m	0 to 4,211,081.215 m	0	4 bytes	126
SAEds06	Distance	m	-2500 to 5531.875 m	-2500 m	2 bytes	39
SAEds07	Distance	m	0 to 250 m	0	1 byte	95
SAEds08	Distance	m	-125 to 125 m	-125 m	1 byte	15
SAEds09	Distance	m	0 to 21,055,406 km	0	4 bytes	38
SAEds10	Distance	m	0 to 526,385,151.9 km	0	4 bytes	36
SAEds11	Distance	m	-160,635 to 160,640 km	-160,635 km	2 bytes	37
SAEds12	Distance	m	0 to 64,255 mm	0	2 bytes	231
SAEds13	Distance	mm	0 to 2500 mm (0 to 2.500 m)	0	1 byte	234
SAEds14	Distance	m	-32000 to 32255 mm (-32.000 to 32.255 m)	0	2 bytes	235
SAEds15	Distance	km	0 to 64,255 km	0	2 bytes	270
SAEec01	Electrical Current	Amps	-1600 to 1612.75 A	-1600 A	2 bytes	104
SAEec02	Electrical Current	Amps	-125 to 125 A	-125 A	1 byte	40
SAEec03	Electrical Current	Amps	0 to 250 A	0	1 byte	41
SAEec04	Electrical Current	Amps	0 to 64,255 Amps	0	2 bytes	146
SAEec05	Electrical Current	Amps	0 to 3212.75 A	0	2 bytes	250
SAEec06	Electrical Current	Amps	0 to 64.255 A	0	2 bytes	143
SAEeg01	Economy, gaseous	km/kg	0 to 125.5 km/kg	0	2 bytes	17
SAEel01	Economy, liquid	km/L	0 to 125.5 km/L	0	2 bytes	16
SAEen01	Energy	kWh	0 to 4211081215 kWh	0	4 bytes	150
SAEer01	Energy, reactive	kVArh	0 to 4211081215 kVArh	0	4 bytes	257
SAEev01	Electrical Voltage	Volts	0 to 3212.75 V	0	2 bytes	80
SAEev02	Electrical Voltage	Volts	0 to 64,255 Volts	0	2 bytes	145
SAEev03	Electrical Voltage	Volts	0 to 642.55 Volts	0	2 bytes	221
SAEev04	Electrical Voltage	Volts	-1606.00 to 1606.75 V	-1606.00 V	2 bytes	249
SAEev05	Electrical Voltage	Volts	0 to 32,899,071 V	0	4 bytes	252
SAEfg01	Flow rate, gaseous	kg/h	0 to 3212.75 kg/h	0	2 bytes	18
SAEfg02	Flow rate, gaseous	kg/h	0 to 12851 kg/h per bit	0	2 bytes	262
SAEfl01	Flow rate, liquid	l/h	0 to 3,212.75 L/h	0	2 bytes	42
SAEfm00	FMI	binary	0 to 31	0	5 bits	215
SAEq01	Frequency	Hz	0 to 501.9921875 Hz	0	2 bytes	144
SAEfr01	Force	N	0 to 321,275 N	0	2 bytes	43
SAEfr02	Force	N	-320,000 to 322,550 N	-320,000 N	2 bytes	127
SAEfr03	Force	N	-100 kN to 150 kN	-100 kN	1 byte	135
SAEfug01	Fuel Used, gaseous	kg	0 to 2,105,540,607.5 kg	0	4 bytes	21
SAEful01	Fuel Used, liquid	l	0 to 2,105,540,607.5 L	0	4 bytes	20
SAEfv01	Flow rate, volumetric	m ³ /h	0 to 6425.5 m ³ /h	0	2 bytes	19
SAEgf01	Group Function	binary	0 to 255	0	1 byte	121
SAEgg01	Governor gain	%/rpm	0 to 50.2 %/rpm	0	2 bytes	22
SAEgr01	Gear Ratio		0 to 642.55	0	2 bytes	23
SAEgv01	Gear Value	gear value	-125 to 125	-125	1 byte	24
SAEgv02	Gear Value	gear value	0 to 250	0	1 byte	101
SAEid01	Identifier, component/software	ID	0 to 250 ID	0	1 byte	25
SAEie01	Inertia	kg/m ²	0 to 257.02 kg-m ²	0	2 bytes	112
SAEio01	Intensity, optical	mW/cm ²	0 to 100 mW/cm ²	0	1 byte	204
SAEkv01	Kinematic viscosity	mm ² /s	0 to 250 mm ² /s	0	1 byte	26
SAEmc01	Mass, cargo	kg	0 to 32,127.5 kg	0	2 bytes	27
SAEmc02	Mass, cargo	kg	0 to 128,510 kg	0	2 bytes	28
SAEmc03	Mass, cargo	kg	0 to 642,550 kg	0	2 bytes	29
SAEmc04	Mass, cargo	kg	0 to 6425.5 kg	0	2 bytes	226

Slot Name	Slot Type	Units	Range	Offset	Length	Slot Identifier
SAEmc05	Mass,cargo	g	0 to 6425.5 g	0	2 bytes	227
SAEmc06	Mass,cargo	kg	0 to 32,899,070 kg	0	3 bytes	122
SAEmc07	Mass,cargo	kg	-16,449,535 to 16,449,535 kg	-16,449,535	3 bytes	267
SAEmd01	Manufacturer defined		manufacturer defined	manufacturer defined	Variable	283
SAENm01	Name (long)	binary	0 to (2 ⁶⁴ - 1)	0	8 bytes	159
SAEOC00	OC	binary	0 to 127	0	7 bits	216
SAEpa01	Power, Apparent	VA	-2,000,000,000 to +2,211,081,215 VA	-2,000,000,000	4 bytes	148
SAEpc01	Percent, position/level	%	0 to 160.6375 %	0	2 bytes	30
SAEpc02	Percent, position/level	%	0 to 102 %	0	10 bits	205
SAEpc03	Percent, position/level	%	0 to 100 %	0	1 byte	44
SAEpc04	Percent, position/level	%	-100 to 100 %	-100 %	1 byte	128
SAEpc05	Percent, position/level	%	-125 to 125 %	-125 %	1 byte	45
SAEpc06	Percent, position/level	%	0 to 250 %	0	1 byte	46
SAEpc07	Percent, position/level	%	-100 to 100 %	-100	2 bytes	251
SAEpc08	Percent, position/level	%	-251 to 250.99 %	-251	2 bytes	256
SAEpc09	Percent, position/level	%	-125 to 132.02%	-125	2 bytes	264
(R) SAEpc10	Percent, position/level	%	0 to 0.875%	0	4 bits	268
SAEpc15	Percent, concentration	%	0 to 62.5 %	0	1 byte	254
SAEpc16	Percent, concentration	%	-12% to 21%	-12 %	2 bytes	237
SAEpd01	Proprietary Data	Manufacturer Determined	Manufacturer Determined	Manufacturer Determined	64 to 14,280 bits	154
SAEpf01	Power Factor		-1.00000 to +2.921814	-1	2 bytes	151
SAEpg00	PGN	binary	0 to 16,777,215	0	3 bytes	116
SAEpp01	Parts Per Million	ppm	-200 to 3012.75 ppm	-200 ppm	2 bytes	236
SAEpr01	Pressure	kPa	-250 kPa TO 251.99 kPa	-250 kPa	2 bytes	52
SAEpr02	Pressure	kPa	0 to 12.5 kPa	0	1 byte	48
SAEpr03	Pressure	kPa	0 to 6,425.5 kPa	0	2 bytes	85
SAEpr04	Pressure	kPa	0 to +8031.875 kPa (0 to 1164.62 psi)	0	2 bytes	138
SAEpr05	Pressure	kPa	0 to 125 kPa	0	1 byte	54
SAEpr06	Pressure	kPa	0 to 32,127.5 kPa	0	2 bytes	50
SAEpr07	Pressure	kPa	0 to 500 kPa	0	1 byte	53
SAEpr08	Pressure	kPa	0 to 128,510 kPa	0	2 bytes	106
SAEpr09	Pressure	kPa	0 to 251 Mpa	0	2 bytes	51
SAEpr10	Pressure	kPa	0 to 1000 kPa	0	1 byte	47
SAEpr11	Pressure	kPa	0 to 1,250 kPa	0	1 byte	1
SAEpr12	Pressure	kPa	0 to 321,275 kPa	0	2 bytes	130
SAEpr13	Pressure	kPa	0 to 2,000 kPa	0	1 byte	2
SAEpr14	Pressure	kPa	0 to 4000 kPa	0	1 byte	49
SAEpr15	Pressure	kPa	0 to 25 MPa	0	1 byte	161
SAEpr16	Pressure	kPa	0 to 12,500 kPa	0	1 byte	229
SAEpr17	Pressure	kPa	-7 to 403 kPa	-7 kPa	1 byte	246
SAEprc01	Pressure Rate Change	Pa/s	0 Pa/s to 6425.5 Pa/s	0	2 bytes	162
SAEpt01	Power, Reactive	VAr	-2,000,000,000 to +2,211,081,215 VAr	-2,000,000,000	4 bytes	149
SAEpw01	Power, Real	W	-2,000,000,000 to +2,211,081,215 Watts	-2,000,000,000	4 bytes	147
SAEpw02	Power, Real	W	0 to 128,510 W	0	2 bytes	107
SAEpw03	Power, Real	kW	0 to 32,127.5 kW	0	2 bytes	55
SAEr01	Ratio	Ratio	0 to 64.255	0	2 bytes	32
SAEr02	Ratio	Ratio	0 to 25.0	0	1 byte	31
SAEr03	Ratio	Ratio	0 to 250	0	1 byte	56
SAEra01	Range	range	-32 to 29 ranges	-32 ranges	6 bits	263
SAErc01	Road Curvature	1/km	-250 to 251.992 1/km	-250 1/km	2 bytes	96
SAErc02	Road Curvature	deg	-90 to 90 deg	-90 deg	2 bytes	261
SAEre01	Record	Record	0 to 250 records	0	1 byte	33
SAEr01	Revolutions	r	0 to 4,211,081,215,000 r	0	4 bytes	34
SAEsa01	Source Address	SA	0 to 255	0	1 byte	35
SAEse01	Selection	selection	0 to 255	0	1 byte	259
SAEsg01	Specific Gravity		0 to 6.4255	0	2 bytes	82
SAESP00	SPN	binary	0 to 524,287	0	19 bits	214
SAEsr01	Specific Resistance	Mohm*m	0 to 25 Mohm*m	0	1 byte	83
SAEst01	Step	step	0 to 250 steps	0	1 byte	84
SAEtc01	Trouble code	trouble code	0 to 250	0	1 byte	274
SAEtd01	Transfer Data	Request Dependent	9 to 1777 bytes of data	Request Dependent	72 to 14,216 bits	155

Slot Name	Slot Type	Units	Range	Offset	Length	Slot Identifier
SAEtd02	Transport Data	Request Dependent	9 to 1784 bytes of data	Request Dependent	72 to 14,272 bits	158
SAEtd03	Test data	Request Dependent	Not defined	Not defined	2 bytes	277
SAEtm01	Time	Seconds	0 to 642.55 ms	0	2 bytes	57
SAEtm02	Time	Seconds	0 to 64.255 s	0	2 bytes	132
SAEtm03	Time	Seconds	0 to 25 s	0	1 byte	59
SAEtm04	Time	Seconds	0 to 62.5 s	0	1 byte	63
SAEtm05	Time	Seconds	0 to 64.255 s	0	2 bytes	64
SAEtm06	Time	Seconds	0 to 4,211,081,215 s	0	4 bytes	6
SAEtm07	Time	Seconds	-125 to 125 mins	-125 min	1 byte	99
SAEtm08	Time	Seconds	0 to 250 mins	0	1 byte	61
SAEtm09	Time	Seconds	0 to 210,554,060.75 hr	0	4 bytes	58
SAEtm10	Time	Seconds	-125 to 125 hr	-125 hr	1 byte	4
SAEtm11	Time	Seconds	0 to 250 hr	0	1 byte	3
SAEtm12	Time	Seconds	-32,127 to 32,128 hr	-32,127 hr	2 bytes	5
SAEtm13	Time	Seconds	0 to 3.289856 s	0	2 bytes	206
SAEtm14	Time	Seconds	0 to 6,425.5 hours	0	2 bytes	224
SAEtm15	Time	Minutes	0 to 64.255 mins	0	2 bytes	238
SAEtm16	Time	milliseconds	0 to 125 ms	0	1 byte	241
SAEtm17	Time	milliseconds	0 to 250 ms	0	1 byte	247
SAEtp01	Temperature	C	-40 to 210 deg C	-40 deg C	1 byte	67
SAEtp02	Temperature	C	-273 to 1735 deg C	-273 deg C	2 bytes	68
SAEtq01	Torque	Nm	-32,000 to 32,255 Nm	-32,000 Nm	2 bytes	69
SAEtq02	Torque	Nm	0 to 64,255 Nm	0	2 bytes	70
SAEtq03	Torque	Nm	0 to 128,510 Nm	0	2 bytes	98
SAEtq04	Torque	Nm	0 to 7500 Nm	0	1 byte	137
SAEva01	Velocity, angular	rad/s	-3.92 to +3.92 rad/s	-3.92 rad/s	2 bytes	114
SAEva02	Velocity, angular	deg/sec	-64 to 64.51 deg/sec	-64 deg/sec	2 bytes	243
SAEvd01	VariantData	VariantDetermined	Variant Determined	Variant Determined	4 bytes	134
SAEvl01	Velocity, linear	m/s	0 to 64.255 m/s	0	2 bytes	125
SAEvl02	Velocity, linear	kph	0 to 250.996 km/h	0	2 bytes	71
SAEvl03	Velocity, linear	kph	-250 to 251.992 km/h	-250 km/h	2 bytes	72
SAEvl04	Velocity, linear	kph	-7.8125 to 7.8125 km/h	-7.8125 km/h	1 byte	74
SAEvl05	Velocity, linear	kph	0 to 250 km/h	0	1 byte	73
SAEvm01	Velocity, magnitude	m/h	0 to 128510 m/h	0	2 bytes	219
SAEvm1	Volume	liters	0 to 2,105,540,607.5 L	0	4 bytes	75
SAEvm2	Volume	liters	0 to 32127.5 liters	0	2 bytes	222
SAEvm3	Volume	liters	-62.5 to 62.5 L	-62.5 L	1 bytes	225
SAEvr01	Velocity, rotational	rpm	0 to 8,031.875 rpm	0	2 bytes	76
SAEvr02	Velocity, rotational	rpm	0 to 32,127.5 rpm	0	2 bytes	78
SAEvr03	Velocity, rotational	rpm	0 to 257,020 rpm	0	2 bytes	77
SAEvr04	Velocity, rotational	rpm	0 to 2,500 rpm	0	1 byte	79
SAEvr05	Velocity, rotational	rpm	0 to 8,000 rpm	0	1 byte	97
SAEvr06	Velocity, rotational	rpm	0 to 64255 rpm	0	2 bytes	223

APPENDIX B SPNs

SPN 16 *Engine Fuel Filter (Suction Side) Differential Pressure (see also SPN 1382)*

Differential pressure measured across the fuel filter located between the fuel tank and the supply pump. See Figures SPN16_A & SPN16_B.

Data Length: 1 byte
 Resolution: 2 kPa/bit, 0 offset
 Data Range: 0 to 500 kPa Operational Range: same as data range
 Type: Measured
 Supporting information: See Appendix D - SPN 16
 PGN

SPN 21 *Engine ECU Temperature (use SPN 1136)*

Temperature of the engine electronic control unit.

(21, 1207 are not to be used - obsolete)

Data Length: 2 bytes
 Resolution: 0.03125 deg C/bit, -273 deg C offset
 Data Range: -273 to 1735 deg C Operational Range: same as data range
 Type: Measured
 Supporting information:
 PGN

SPN 22 *Engine Extended Crankcase Blow-by Pressure*

Differential crankcase blow-by pressure as measured through a tube with a venturi.

(1264 not to be used – obsolete)

Data Length: 1 byte
 Resolution: 0.05 kPa/bit, 0 offset
 Data Range: 0 to 12.5 kPa Operational Range: same as data range
 Type: Measured
 Supporting information:
 PGN 65263

SPN 27 *Engine Exhaust Gas Recirculation Valve Position*

The position of the exhaust gas recirculation valve expressed as a percentage of full travel. Zero percent means the valve is closed and no exhaust gas is flowing into the intake air stream. One hundred percent means the valve is fully opened.

Data Length: 2 bytes
 Resolution: 0.0025 %/bit, 0 offset
 Data Range: 0 to 160.6375 % Operational Range: same as data range
 Type: Measured
 Supporting information:
 PGN 64916

SPN 29 Accelerator Pedal Position 2

The ratio of actual position of the second analog engine speed/torque request input device (such as an accelerator pedal or throttle lever) to the maximum position of the input device. This parameter is intended for secondary accelerator control in an application. If an application has only one accelerator control, use SPN 91.

In marine applications, this will typically be the operator's second throttle lever.

If a low idle validation switch is used in conjunction with accelerator pedal position 2, use Accelerator Pedal Low Idle Switch 2, SPN 2970.

NOTE—See SPNs 91, 28, and 974 for additional accelerator position parameters.

Data Length: 1 byte
Resolution: 0.4 %/bit, 0 offset
Data Range: 0 to 100 % Operational Range: same as data range
Type: Measured
Supporting information:
PGN 61443

SPN 38 (R) Fuel Level 2

Ratio of volume of fuel to the total volume of fuel in the second or right-side storage container. When Fuel Level 2 is not used, Fuel Level 1 (SPN 96) represents the total fuel in all fuel storage containers.

Data Length: 1 byte
Resolution: 0.4 %/bit, 0 offset
Data Range: 0 to 100 % Operational Range: same as data range
Type: Measured
Supporting information:
PGN 65276

SPN 39 Tire Pressure Check Interval

The interval at which the system will check the tire pressures (e.g., 5, 10, 15 min.).

NOTE - A value of 0 indicates continuous (real time) pressure readings.

Data Length: 1 byte
Resolution: 1 min/bit, 0 offset
Data Range: 0 to 250 mins Operational Range: same as data range
Type: Status
Supporting information:
PGN 65144

SPN 46 Pneumatic Supply Pressure

The pneumatic pressure in the main reservoir, sometimes referred to as the wet tank.

Data Length: 1 byte
Resolution: 8 kPa/bit, 0 offset
Data Range: 0 to 2,000 kPa Operational Range: same as data range
Type: Measured
Supporting information:
PGN 65198

SPN 51 Engine Throttle Position

The position of the valve used to regulate the supply of a fluid, usually air or fuel/air mixture, to an engine. 0% represents no supply and 100% is full supply.

Data Length: 1 byte
Resolution: 0.4 %/bit, 0 offset
Data Range: 0 to 100 % Operational Range: same as data range
Type: Measured
Supporting information:
PGN 65266

SPN 52 Engine Intercooler Temperature

Temperature of liquid found in the intercooler located after the turbocharger.

Data Length: 1 byte
Resolution: 1 deg C/bit, -40 deg C offset
Data Range: -40 to 210 deg C Operational Range: same as data range
Type: Measured
Supporting information:
PGN 65262

SPN 53 Transmission Synchronizer Clutch Value

The current modulated value for the air supply to the synchronizer clutch.

Data Length: 1 byte
Resolution: 0.4 %/bit, 0 offset
Data Range: 0 to 100 % Operational Range: same as data range
Type: Measured
Supporting information:
PGN 65221

SPN 54 Transmission Synchronizer Brake Value

The current modulated value for the air supply to the synchronizer brake.

Data Length: 1 byte
Resolution: 0.4 %/bit, 0 offset
Data Range: 0 to 100 % Operational Range: same as data range
Type: Measured
Supporting information:
PGN 65221

SPN 59 **Transmission Shift Finger Gear Position**

The current position of the shift finger in the gear direction.

Data Length: 1 byte
Resolution: 0.4 %/bit, 0 offset
Data Range: 0 to 100 % Operational Range: same as data range
Type: Measured
Supporting information:
PGN 65223

SPN 60 **Transmission Shift Finger Rail Position**

The current position of the shift finger in the rail direction.

Data Length: 1 byte
Resolution: 0.4 %/bit, 0 offset
Data Range: 0 to 100 % Operational Range: same as data range
Type: Measured
Supporting information:
PGN 65223

SPN 69 **Two Speed Axle Switch**

Switch signal which indicates the current axle range.

00 - Low speed range
01 - High speed range
10 - Error
11 - Not available

Data Length: 2 bits
Resolution: 4 states/2 bit, 0 offset
Data Range: 0 to 3 Operational Range: same as data range
Type: Measured
Supporting information:
PGN 65265

SPN 70 **Parking Brake Switch**

Switch signal which indicates when the parking brake is set. In general the switch actuated by the operator's park brake control, whether a pedal, lever or other control mechanism. (See also SPN 619)

00 - Parking brake not set
01 - Parking brake set
10 - Error
11 - Not available

Data Length: 2 bits
Resolution: 4 states/2 bit, 0 offset
Data Range: 0 to 3 Operational Range: same as data range
Type: Measured
Supporting information:
PGN 65265

SPN 72 Engine Blower Bypass Valve Position

Relative position of the blower bypass valve.

Data Length: 1 byte

Resolution: 0.4 %/bit, 0 offset

Data Range: 0 to 100 % Operational Range: same as data range

Type: Measured

Supporting information:

PGN 65277

SPN 73 Auxiliary Pump Pressure

Gage pressure of auxiliary water pump driven as a PTO device.

Data Length: 1 byte

Resolution: 16 kPa/bit, 0 offset

Data Range: 0 to 4000 kPa Operational Range: same as data range

Type: Measured

Supporting information:

PGN 65278

SPN 74 Maximum Vehicle Speed Limit

Maximum vehicle velocity allowed.

Data Length: 1 byte

Resolution: 1 km/h per bit, 0 offset

Data Range: 0 to 250 km/h Operational Range: same as data range

Type: Measured

Supporting information:

PGN 65261

SPN 75 Steering Axle Temperature

Temperature of lubricant in steering axle.

Data Length: 1 byte

Resolution: 1 deg C/bit, -40 deg C offset

Data Range: -40 to 210 deg C Operational Range: same as data range

Type: Measured

Supporting information:

PGN 65273

SPN 79 Road Surface Temperature

Indicated temperature of road surface over which vehicle is operating.

Data Length: 2 bytes

Resolution: 0.03125 deg C/bit, -273 deg C offset

Data Range: -273 to 1735 deg C Operational Range: same as data range

Type: Measured

Supporting information:

PGN 65269

SPN 80 Washer Fluid Level

Ratio of volume of liquid to total container volume of fluid reservoir in windshield wash system.

Data Length: 1 byte

Resolution: 0.4 %/bit, 0 offset

Data Range: 0 to 100 % Operational Range: same as data range

Type: Measured

Supporting information:

PGN 65276

SPN 81 (R) Engine Diesel Particulate Filter Inlet Pressure

Exhaust back pressure as a result of particle accumulation on filter media placed in the exhaust stream. See SPN 3609 for better resolution.

Data Length: 1 byte

Resolution: 0.5 kPa/bit, 0 offset

Data Range: 0 to 125 kPa Operational Range: same as data range

Type: Measured

Supporting information:

PGN 65270

SPN 82 Engine Air Start Pressure

Gage pressure of air in an engine starting system that utilizes compressed air to provide the force required to rotate the crankshaft.

Data Length: 1 byte

Resolution: 4 kPa/bit, 0 offset

Data Range: 0 to 1000 kPa Operational Range: same as data range

Type: Measured

Supporting information:

PGN 65246

SPN 84 Wheel-Based Vehicle Speed

Speed of the vehicle as calculated from wheel or tailshaft speed.

Data Length: 2 bytes

Resolution: 1/256 km/h per bit, 0 offset

Data Range: 0 to 250.996 km/h Operational Range: same as data range

Type: Measured

Supporting information:

PGN 65265

SPN 86 Cruise Control Set Speed

Value of set (chosen) velocity of velocity control system.

Data Length: 1 byte

Resolution: 1 km/h per bit, 0 offset

Data Range: 0 to 250 km/h Operational Range: same as data range

Type: Measured

Supporting information:

PGN 65265

SPN 87 Cruise Control High Set Limit Speed

Maximum vehicle velocity at which cruise can be set.

Data Length: 1 byte

Resolution: 1 km/h per bit, 0 offset

Data Range: 0 to 250 km/h Operational Range: same as data range

Type: Measured

Supporting information:

PGN 65261

SPN 88 Cruise Control Low Set Limit Speed

Minimum vehicle velocity at which cruise can be set or minimum vehicle velocity for cruise operation before it will exit cruise control operation.

Data Length: 1 byte

Resolution: 1 km/h per bit, 0 offset

Data Range: 0 to 250 km/h Operational Range: same as data range

Type: Measured

Supporting information:

PGN 65261

SPN 90 Power Takeoff Oil Temperature

Temperature of lubricant in device used to transmit engine power to auxiliary equipment.

Data Length: 1 byte

Resolution: 1 deg C/bit, -40 deg C offset

Data Range: -40 to 210 deg C Operational Range: same as data range

Type: Measured

Supporting information:

PGN 65264

SPN 91 Accelerator Pedal Position 1

The ratio of actual position of the analog engine speed/torque request input device (such as an accelerator pedal or throttle lever) to the maximum position of the input device. This parameter is intended for the primary accelerator control in an application. If an application has only one accelerator control, use SPN 91.

For on-highway vehicles, this will typically be the operator's accelerator pedal. Although it is used as an input to determine powertrain demand, it also provides anticipatory information to transmission and ASR algorithms about driver actions.

In marine applications, this will typically be the operator's throttle lever.

If a low idle validation switch is used in conjunction with accelerator pedal position 1, use Accelerator Pedal Low Idle Switch 1, SPN 558.

Data Length: 1 byte

Resolution: 0.4 %/bit, 0 offset

Data Range: 0 to 100 % Operational Range: same as data range

Type: Measured

Supporting information:

PGN 61443

SPN 92 Engine Percent Load At Current Speed

The ratio of actual engine percent torque (indicated) to maximum indicated torque available at the current engine speed, clipped to zero torque during engine braking.

Data Length: 1 byte

Resolution: 1 %/bit, 0 offset

Data Range: 0 to 250 % Operational Range: 0 to 125%

Type: Status

Supporting information:

PGN 61443

SPN 94 Engine Fuel Delivery Pressure

Gage pressure of fuel in system as delivered from supply pump to the injection pump. See Figures SPN16_A & SPN16_B.

Data Length: 1 byte

Resolution: 4 kPa/bit, 0 offset

Data Range: 0 to 1000 kPa Operational Range: same as data range

Type: Measured

Supporting information:

PGN 65263

SPN 95 Engine Fuel Filter Differential Pressure

Change in fuel delivery pressure, measured across the filter, due to accumulation of solid or semisolid matter on the filter element. See Figures SPN16_A & SPN16_B.

Data Length: 1 byte
 Resolution: 2 kPa/bit, 0 offset
 Data Range: 0 to 500 kPa Operational Range: same as data range
 Type: Measured
 Supporting information:
 PGN 65276

SPN 96 (R) Fuel Level 1

Ratio of volume of fuel to the total volume of fuel storage container.

When Fuel Level 2 (SPN 38) is not used, Fuel Level 1 represents the total fuel in all fuel storage containers. When Fuel Level 2 is used, Fuel Level 1 represents the fuel level in the primary or left-side fuel storage container.

Data Length: 1 byte
 Resolution: 0.4 %/bit, 0 offset
 Data Range: 0 to 100 % Operational Range: same as data range
 Type: Measured
 Supporting information:
 PGN 65276

SPN 97 Water In Fuel Indicator

Signal which indicates the presence of water in the fuel.

00 - No
 01 - Yes
 10 - Error
 11 - Not available

Data Length: 2 bits
 Resolution: 4 states/2 bit, 0 offset
 Data Range: 0 to 3 Operational Range: same as data range
 Type: Measured
 Supporting information:
 PGN 65279

SPN 98 Engine Oil Level

Ratio of current volume of engine sump oil to maximum required volume.

Data Length: 1 byte
 Resolution: 0.4 %/bit, 0 offset
 Data Range: 0 to 100 % Operational Range: same as data range
 Type: Measured
 Supporting information:
 PGN 65263

SPN 99 Engine Oil Filter Differential Pressure

Change in engine oil pressure, measured across the filter, due to the filter and any accumulation of solid or semisolid material on or in the filter.

Data Length: 1 byte
Resolution: 0.5 kPa/bit, 0 offset
Data Range: 0 to 125 kPa Operational Range: same as data range
Type: Measured
Supporting information:
PGN 65276

SPN 100 Engine Oil Pressure

Gage pressure of oil in engine lubrication system as provided by oil pump.

Data Length: 1 byte
Resolution: 4 kPa/bit, 0 offset
Data Range: 0 to 1000 kPa Operational Range: same as data range
Type: Measured
Supporting information:
PGN 65263

SPN 101 Engine Crankcase Pressure

Gage pressure inside engine crankcase.

Data Length: 2 bytes
Resolution: 1/128 kPa/bit, -250 kPa offset
Data Range: -250 kPa TO 251.99 kPa Operational Range: same as data range
Type: Measured
Supporting information:
PGN 65263

SPN 102 Engine Intake Manifold #1 Pressure

The gage pressure measurement of the air intake manifold. If there are multiple air pressure sensors in the intake stream, this is the last one in flow direction before entering the combustion chamber. This should be the pressure used to drive gauges and displays. See also SPNs 1127-1130 and SPN 3562 for alternate range and resolution. If there is only one pressure measurement of the air intake manifold to report and this range and resolution is adequate, this parameter should

Data Length: 1 byte
Resolution: 2 kPa/bit, 0 offset
Data Range: 0 to 500 kPa Operational Range: same as data range
Type: Measured
Supporting information:
PGN 65270

SPN 103 Engine Turbocharger 1 Speed

Rotational velocity of rotor in the turbocharger.

Data Length: 2 bytes

Resolution: 4 rpm/bit, 0 offset

Data Range: 0 to 257,020 rpm Operational Range: same as data range

Type: Measured

Supporting information:

PGN 65245

SPN 104 Engine Turbocharger Lube Oil Pressure 1

Gage pressure of oil in turbocharger lubrication system.

Data Length: 1 byte

Resolution: 4 kPa/bit, 0 offset

Data Range: 0 to 1000 kPa Operational Range: same as data range

Type: Measured

Supporting information:

PGN 65245

SPN 105 Engine Intake Manifold 1 Temperature

Temperature of pre-combustion air found in intake manifold of engine air supply system.

Data Length: 1 byte

Resolution: 1 deg C/bit, -40 deg C offset

Data Range: -40 to 210 deg C Operational Range: same as data range

Type: Measured

Supporting information:

PGN 65270

SPN 106 Engine Air Inlet Pressure

Absolute air pressure at inlet to intake manifold or air box.

Data Length: 1 byte

Resolution: 2 kPa/bit, 0 offset

Data Range: 0 to 500 kPa Operational Range: same as data range

Type: Measured

Supporting information:

PGN 65270

SPN 107 Engine Air Filter 1 Differential Pressure

Change in engine air system pressure, measured across the filter, due to the filter and any accumulation of solid foreign matter on or in the filter.

This is the measurement of the first filter in a multiple air filter system. In a single air filter application, this is the only SPN used. Filter numbering follows the guidelines noted in section, Naming Convention For Engine Parameters.

Data Length: 1 byte
Resolution: 0.05 kPa/bit, 0 offset
Data Range: 0 to 12.5 kPa Operational Range: same as data range
Type: Measured
Supporting information:
PGN 65270

SPN 108 Barometric Pressure

Absolute air pressure of the atmosphere. See Figures SPN16_A & SPN16_B.

Data Length: 1 byte
Resolution: 0.5 kPa/bit, 0 offset
Data Range: 0 to 125 kPa Operational Range: same as data range
Type: Measured
Supporting information:
PGN 65269

SPN 109 Engine Coolant Pressure

Gage pressure of liquid found in engine cooling system.

Data Length: 1 byte
Resolution: 2 kPa/bit, 0 offset
Data Range: 0 to 500 kPa Operational Range: same as data range
Type: Measured
Supporting information:
PGN 65263

SPN 110 Engine Coolant Temperature

Temperature of liquid found in engine cooling system.

Data Length: 1 byte
Resolution: 1 deg C/bit, -40 deg C offset
Data Range: -40 to 210 deg C Operational Range: same as data range
Type: Measured
Supporting information:
PGN 65262

SPN 111 Engine Coolant Level

Ratio of volume of liquid found in engine cooling system to total cooling system volume. Typical monitoring location is in the coolant expansion tank.

Data Length: 1 byte
Resolution: 0.4 %/bit, 0 offset
Data Range: 0 to 100 % Operational Range: same as data range
Type: Measured
Supporting information:
PGN 65263

SPN 112 Engine Coolant Filter Differential Pressure

Change in coolant pressure, measured across the filter, due to the filter and any accumulation of solid or semisolid matter on or in the filter.

Data Length: 1 byte
Resolution: 0.5 kPa/bit, 0 offset
Data Range: 0 to 125 kPa Operational Range: same as data range
Type: Measured
Supporting information:
PGN 65270

SPN 114 Net Battery Current

Net flow of electrical current into/out of the battery or batteries.

Data Length: 1 byte
Resolution: 1 A/bit, -125 A offset
Data Range: -125 to 125 A Operational Range: same as data range
Type: Measured
Supporting information:
PGN 65271

SPN 115 Alternator Current

Measure of electrical current flow from the alternator. Alternator Current (High Range/Resolution) parameter SPN 1795 has a higher range and resolution of the same parameter.

Data Length: 1 byte
Resolution: 1 A/bit, 0 offset
Data Range: 0 to 250 A Operational Range: same as data range
Type: Measured
Supporting information:
PGN 65271

SPN 116 Brake Application Pressure

Gage pressure of compressed air or fluid in vehicle braking system measured at the brake chamber when brake shoe (or pad) is placed against brake drum (or disc).

Data Length: 1 byte
Resolution: 4 kPa/bit, 0 offset
Data Range: 0 to 1000 kPa Operational Range: same as data range
Type: Measured
Supporting information:
PGN 65274

SPN 117 Brake Primary Pressure

Gage pressure of air in the primary, or supply side, of the air brake system.

Data Length: 1 byte
Resolution: 4 kPa/bit, 0 offset
Data Range: 0 to 1000 kPa Operational Range: same as data range
Type: Measured
Supporting information:
PGN 65274

SPN 118 Brake Secondary Pressure

Gage pressure of air in the secondary, or service side, of the air brake system.

Data Length: 1 byte
Resolution: 4 kPa/bit, 0 offset
Data Range: 0 to 1000 kPa Operational Range: same as data range
Type: Measured
Supporting information:
PGN 65274

SPN 119 Hydraulic Retarder Pressure

Gage pressure of oil in hydraulic retarder system.

Data Length: 1 byte
Resolution: 16 kPa/bit, 0 offset
Data Range: 0 to 4000 kPa Operational Range: same as data range
Type: Measured
Supporting information:
PGN 65275

SPN 120 Hydraulic Retarder Oil Temperature

Temperature of oil found in a hydraulic retarder.

Data Length: 1 byte

Resolution: 1 deg C/bit, -40 deg C offset

Data Range: -40 to 210 deg C Operational Range: same as data range

Type: Measured

Supporting information:

PGN 65275

SPN 123 Clutch Pressure

Gage pressure of oil within a wet clutch.

Data Length: 1 byte

Resolution: 16 kPa/bit, 0 offset

Data Range: 0 to 4000 kPa Operational Range: same as data range

Type: Measured

Supporting information:

PGN 65272

SPN 124 Transmission Oil Level

Ratio of volume of transmission sump oil to recommended volume.

Data Length: 1 byte

Resolution: 0.4 %/bit, 0 offset

Data Range: 0 to 100 % Operational Range: same as data range

Type: Measured

Supporting information:

PGN 65272

SPN 126 Transmission Filter Differential Pressure

Change in transmission fluid pressure, measured after the filter, due to accumulation of solid or semisolid material on or in the filter.

Data Length: 1 byte

Resolution: 2 kPa/bit, 0 offset

Data Range: 0 to 500 kPa Operational Range: same as data range

Type: Measured

Supporting information:

PGN 65272

SPN 127 *Transmission Oil Pressure*

Gage pressure of lubrication fluid in transmission, measured after pump.

Data Length: 1 byte

Resolution: 16 kPa/bit, 0 offset

Data Range: 0 to 4000 kPa Operational Range: same as data range

Type: Measured

Supporting information:

PGN 65272

SPN 129 *Engine Injector Metering Rail 2 Pressure (duplicate, use SPN 1349)*

The gage pressure of fuel in the metering rail #2 as delivered from the supply pump to the injector metering inlet. See Figure SPN16_A for fuel system related parameters. Although the figure does not show rail #2 it does show the relationship of rail pressure to other signals.

(Obsolete - use SPN 1349)

Data Length: 2 bytes

Resolution: 1/256 MPa/bit, 0 offset

Data Range: 0 to 251 Mpa Operational Range: same as data range

Type: Measured

Supporting information:

PGN

SPN 132 *Engine Inlet Air Mass Flow Rate*

Mass flow rate of fresh air entering the engine air intake, before any EGR mixer, if used. Flow rate of fresh air conducted to the engine cylinders to support combustion.

Data Length: 2 bytes

Resolution: 0.05 kg/h per bit, 0 offset

Data Range: 0 to 3212.75 kg/h Operational Range: same as data range

Type: Measured

Supporting information:

PGN 61450

SPN 136 *Auxiliary Vacuum Pressure Reading*

Identifies the current vacuum pressure (relative to atmosphere) that is configured uniquely per application. Not to be used in place of defined parameters.

Data Length: 2 bytes

Resolution: 0.5 kPa/bit, 0 offset

Data Range: 0 to 32,127.5 kPa Operational Range: same as data range

Type: Measured

Supporting information:

PGN 65143

SPN 137 Auxiliary Gage Pressure Reading 1

Identifies the current gage pressure (relative to atmosphere) that is configured uniquely per application. Not to be used in place of defined parameters.

Data Length: 2 bytes
Resolution: 0.5 kPa/bit, 0 offset
Data Range: 0 to 32,127.5 kPa Operational Range: same as data range
Type: Measured
Supporting information:
PGN 65143

SPN 138 Auxiliary Absolute Pressure Reading

Identifies the current absolute pressure (relative to 0 pressure) that is configured uniquely per application. Not to be used in place of defined parameters.

Data Length: 2 bytes
Resolution: 0.5 kPa/bit, 0 offset
Data Range: 0 to 32,127.5 kPa Operational Range: same as data range
Type: Measured
Supporting information:
PGN 65143

SPN 141 Trailer, Tag Or Push Channel Tire Pressure Target

The tire pressure control system's target gage pressure for the trailer, tag, or push group of tires.

Data Length: 2 bytes
Resolution: 0.5 kPa/bit, 0 offset
Data Range: 0 to 32,127.5 kPa Operational Range: same as data range
Type: Measured
Supporting information:
PGN 65145

SPN 142 Drive Channel Tire Pressure Target

The tire pressure control system's target gage pressure for the drive group of tires.

Data Length: 2 bytes
Resolution: 0.5 kPa/bit, 0 offset
Data Range: 0 to 32,127.5 kPa Operational Range: same as data range
Type: Measured
Supporting information:
PGN 65145

SPN 143 Steer Channel Tire Pressure Target

The tire pressure control system's target gage pressure for the steer group of tires.

Data Length: 2 bytes

Resolution: 0.5 kPa/bit, 0 offset

Data Range: 0 to 32,127.5 kPa Operational Range: same as data range

Type: Measured

Supporting information:

PGN 65145

SPN 144 Trailer, Tag Or Push Channel Tire Pressure

The latest gage pressure reading of the trailer, tag, or push group of tires, as opposed to the pressure in each tire.

Data Length: 2 bytes

Resolution: 0.5 kPa/bit, 0 offset

Data Range: 0 to 32,127.5 kPa Operational Range: same as data range

Type: Measured

Supporting information:

PGN 65146

SPN 145 Drive Channel Tire Pressure

The latest gage pressure reading of the drive group of tires, as opposed to the pressure in each tire.

Data Length: 2 bytes

Resolution: 0.5 kPa/bit, 0 offset

Data Range: 0 to 32,127.5 kPa Operational Range: same as data range

Type: Measured

Supporting information:

PGN 65146

SPN 146 Steer Channel Tire Pressure

The latest gage pressure reading of the steer group of tires, as opposed to the pressure in each tire.

Data Length: 2 bytes

Resolution: 0.5 kPa/bit, 0 offset

Data Range: 0 to 32,127.5 kPa Operational Range: same as data range

Type: Measured

Supporting information:

PGN 65146

SPN 156 Engine Injector Timing Rail 1 Pressure

The gage pressure of fuel in the timing rail delivered from the supply pump to the injector timing inlet.

Data Length: 2 bytes

Resolution: 1/256 MPa/bit, 0 offset

Data Range: 0 to 251 Mpa Operational Range: same as data range

Type: Measured

Supporting information: See Appendix D - SPN 16

PGN 65243

SPN 157 Engine Injector Metering Rail 1 Pressure

The gage pressure of fuel in the primary, or first, metering rail as delivered from the supply pump to the injector metering inlet. See Figure SPN16_A.

Data Length: 2 bytes

Resolution: 1/256 MPa/bit, 0 offset

Data Range: 0 to 251 Mpa Operational Range: same as data range

Type: Measured

Supporting information:

PGN 65243

SPN 158 Keyswitch Battery Potential

Battery potential measured at the input of the electronic control unit supplied through a keyswitch or similar switching

Data Length: 2 bytes

Resolution: 0.05 V/bit, 0 offset

Data Range: 0 to 3212.75 V Operational Range: same as data range

Type: Measured

Supporting information:

PGN 65271

SPN 159 Engine Gas Supply Pressure

Gage pressure of gas supply to fuel metering device.

Data Length: 2 bytes

Resolution: 0.5 kPa/bit, 0 offset

Data Range: 0 to 32,127.5 kPa Operational Range: same as data range

Type: Measured

Supporting information:

PGN 65277

SPN 160 *Main Shaft Speed*

Rotational velocity of the first intermediate shaft of the transmission.

Data Length: 2 bytes

Resolution: 0.125 rpm/bit, 0 offset

Data Range: 0 to 8,031.875 rpm Operational Range: same as data range

Type: Measured

Supporting information:

PGN

SPN 161 *Transmission Input Shaft Speed*

Rotational velocity of the primary shaft transferring power into the transmission. When a torque converter is present, it is the output of the torque converter.

Data Length: 2 bytes

Resolution: 0.125 rpm/bit, 0 offset

Data Range: 0 to 8,031.875 rpm Operational Range: same as data range

Type: Measured

Supporting information:

PGN 61442

SPN 162 *Transmission Requested Range*

Range selected by the operator. Characters may include P, Rx, Rx-1...R2, R1, R, Nx, Nx-1...N2, N1, N, D, D1, D2..., Dx, L, L1, L2..., Lx-1, 1, 2, 3,... If only one displayed character is required, the second character shall be used and the first character shall be a space (ASCII 32) or a control character (ASCII 0 to 31). If the first character is a control character, refer to the manufacturer's application document for definition.

Data Length: 2 bytes

Resolution: ASCII, 0 offset

Data Range: 0 to 255 per byte Operational Range: same as data range

Type: Status

Supporting information:

PGN 61445

SPN 163 *Transmission Current Range*

Range currently being commanded by the transmission control system. Characters may include P, Rx, Rx-1...R2, R1, R, Nx, Nx-1...N2, N1, N, D, D1, D2..., Dx, L, L1, L2..., Lx-1, 1, 2, 3,... If only one displayed character is required, the second character shall be used and the first character shall be a space (ASCII 32) or a control character (ASCII 0 to 31). If the first character is a control character, refer to the manufacturer's application document for definition.

Data Length: 2 bytes

Resolution: ASCII, 0 offset

Data Range: 0 to 255 per byte Operational Range: same as data range

Type: Status

Supporting information:

PGN 61445

SPN 164 Engine Injection Control Pressure

The gage pressure of the engine oil in the hydraulic accumulator that powers an intensifier used for fuel injection.

Data Length: 2 bytes

Resolution: 1/256 MPa/bit, 0 offset

Data Range: 0 to 251 Mpa Operational Range: same as data range

Type: Measured

Supporting information:

PGN 65243

SPN 165 Compass Bearing

Present compass bearing of vehicle.

Data Length: 2 bytes

Resolution: 1/128 deg/bit, 0 offset

Data Range: 0 to 501.99 deg Operational Range: same as data range

Type: Measured

Supporting information:

PGN 65256

SPN 166 Engine Rated Power

Net brake power that the engine will deliver continuously, specified for a given application at a rated speed.

Data Length: 2 bytes

Resolution: 0.5 kW/bit, 0 offset

Data Range: 0 to 32,127.5 kW Operational Range: same as data range

Type: Measured

Supporting information:

PGN 65214

SPN 167 Charging System Potential (Voltage)

Electrical potential measured at the charging system output. The charging system may be any device charging the batteries. This includes alternators, generators, solid state charger and other charging devices.

Data Length: 2 bytes

Resolution: 0.05 V/bit, 0 offset

Data Range: 0 to 3212.75 V Operational Range: same as data range

Type: Measured

Supporting information:

PGN 65271

SPN 168 Battery Potential / Power Input 1

This parameter measures the first source of battery potential as measured at the input of the ECM/actuator etc. coming from one or more batteries, irrespective of the distance between the component and the battery. This SPN is also used when ECM's are interconnected in a series configuration, where the source of power is coming directly or indirectly from the same battery/batteries.

Data Length: 2 bytes
Resolution: 0.05 V/bit, 0 offset
Data Range: 0 to 3212.75 V Operational Range: same as data range
Type: Measured
Supporting information: See Appendix D - PGN 65104
PGN 65271

SPN 169 Cargo Ambient Temperature

Temperature of air inside vehicle container used to accommodate cargo.

Data Length: 2 bytes
Resolution: 0.03125 deg C/bit, -273 deg C offset
Data Range: -273 to 1735 deg C Operational Range: same as data range
Type: Measured
Supporting information:
PGN 65276

SPN 170 Cab Interior Temperature

Temperature of air inside the part of the vehicle that encloses the driver and vehicle operating controls.

Note: See SPN 1662 and SPN 1691.

Data Length: 2 bytes
Resolution: 0.03125 deg C/bit, -273 deg C offset
Data Range: -273 to 1735 deg C Operational Range: same as data range
Type: Measured
Supporting information:
PGN 65269

SPN 171 Ambient Air Temperature

Temperature of air surrounding vehicle.

Data Length: 2 bytes
Resolution: 0.03125 deg C/bit, -273 deg C offset
Data Range: -273 to 1735 deg C Operational Range: same as data range
Type: Measured
Supporting information:
PGN 65269

SPN 172 Engine Air Inlet Temperature

Temperature of air entering vehicle air induction system.

Data Length: 1 byte

Resolution: 1 deg C/bit, -40 deg C offset

Data Range: -40 to 210 deg C Operational Range: same as data range

Type: Measured

Supporting information:

PGN 65269

SPN 173 Engine Exhaust Gas Temperature

Temperature of combustion byproducts leaving the engine. See SPNs 2433 and 2434 for engines with more than one exhaust gas temperature measurement.

Data Length: 2 bytes

Resolution: 0.03125 deg C/bit, -273 deg C offset

Data Range: -273 to 1735 deg C Operational Range: same as data range

Type: Measured

Supporting information:

PGN 65270

SPN 174 Engine Fuel Temperature 1

Temperature of fuel (or gas) passing through the first fuel control system. See SPN 3468 for the second control system

Data Length: 1 byte

Resolution: 1 deg C/bit, -40 deg C offset

Data Range: -40 to 210 deg C Operational Range: same as data range

Type: Measured

Supporting information:

PGN 65262

SPN 175 Engine Oil Temperature 1

Temperature of the engine lubricant.

Data Length: 2 bytes

Resolution: 0.03125 deg C/bit, -273 deg C offset

Data Range: -273 to 1735 deg C Operational Range: same as data range

Type: Measured

Supporting information:

PGN 65262

SPN 176 Engine Turbocharger Oil Temperature

Temperature of the turbocharger lubricant.

Data Length: 2 bytes

Resolution: 0.03125 deg C/bit, -273 deg C offset

Data Range: -273 to 1735 deg C Operational Range: same as data range

Type: Measured

Supporting information:

PGN 65262

SPN 177 Transmission Oil Temperature

Temperature of the transmission lubricant.

Data Length: 2 bytes

Resolution: 0.03125 deg C/bit, -273 deg C offset

Data Range: -273 to 1735 deg C Operational Range: same as data range

Type: Measured

Supporting information:

PGN 65272

SPN 180 Trailer Weight

Total mass of freight-carrying vehicle designed to be pulled by truck, including the weight of the contents.

Data Length: 2 bytes

Resolution: 2 kg/bit, 0 offset

Data Range: 0 to 128,510 kg Operational Range: same as data range

Type: Measured

Supporting information:

PGN 65258

SPN 181 Cargo Weight

The mass of freight carried.

Data Length: 2 bytes

Resolution: 2 kg/bit, 0 offset

Data Range: 0 to 128,510 kg Operational Range: same as data range

Type: Measured

Supporting information:

PGN 65258

SPN 182 Engine Trip Fuel

Fuel consumed during all or part of a journey.

Data Length: 4 bytes

Resolution: 0.5 L/bit, 0 offset

Data Range: 0 to 2,105,540,607.5 L Operational Range: same as data range

Type: Measured

Supporting information:

PGN 65257

SPN 183 Engine Fuel Rate

Amount of fuel consumed by engine per unit of time.

Data Length: 2 bytes

Resolution: 0.05 L/h per bit, 0 offset

Data Range: 0 to 3,212.75 L/h Operational Range: same as data range

Type: Measured

Supporting information:

PGN 65266

SPN 184 Engine Instantaneous Fuel Economy

Current fuel economy at current vehicle velocity.

Data Length: 2 bytes

Resolution: 1/512 km/L per bit, 0 offset

Data Range: 0 to 125.5 km/L Operational Range: same as data range

Type: Measured

Supporting information:

PGN 65266

SPN 185 Engine Average Fuel Economy

Average of instantaneous fuel economy for that segment of vehicle operation of interest.

Data Length: 2 bytes

Resolution: 1/512 km/L per bit, 0 offset

Data Range: 0 to 125.5 km/L Operational Range: same as data range

Type: Measured

Supporting information:

PGN 65266

SPN 186 **Power Takeoff Speed**

Rotational velocity of device used to transmit engine power to auxiliary equipment.

Data Length: 2 bytes

Resolution: 0.125 rpm/bit, 0 offset

Data Range: 0 to 8,031.875 rpm Operational Range: same as data range

Type: Measured

Supporting information:

PGN 65264

SPN 187 **Power Takeoff Set Speed**

Rotational velocity selected by operator for device used to transmit engine power to auxiliary equipment.

Data Length: 2 bytes

Resolution: 0.125 rpm/bit, 0 offset

Data Range: 0 to 8,031.875 rpm Operational Range: same as data range

Type: Measured

Supporting information:

PGN 65264

SPN 188 **Engine Speed At Idle, Point 1 (Engine Configuration)**

Stationary low idle speed of engine which includes influences due to engine temperature (after power up) and other stationary changes (calibration offsets, sensor failures, etc). This parameter is point 1 of the engine configuration map (see PGN 65251).

Data Length: 2 bytes

Resolution: 0.125 rpm/bit, 0 offset

Data Range: 0 to 8,031.875 rpm Operational Range: same as data range

Type: Measured

Supporting information:

PGN 65251

SPN 189 **Engine Rated Speed**

The maximum governed rotational velocity of the engine crankshaft under full load conditions. Note that the engine speed at point 2 (SPN 528) is equal to rated engine speed only in the case when the engine has not been derated. Please also reference PGN 65251.

Data Length: 2 bytes

Resolution: 0.125 rpm/bit, 0 offset

Data Range: 0 to 8,031.875 rpm Operational Range: same as data range

Type: Measured

Supporting information:

PGN 65214

SPN 190 Engine Speed

Actual engine speed which is calculated over a minimum crankshaft angle of 720 degrees divided by the number of cylinders.

Data Length: 2 bytes
 Resolution: 0.125 rpm/bit, 0 offset
 Data Range: 0 to 8,031.875 rpm Operational Range: same as data range
 Type: Measured
 Supporting information:
 PGN 61444

SPN 191 Transmission Output Shaft Speed

Calculated speed of the transmission output shaft.

Data Length: 2 bytes
 Resolution: 0.125 rpm/bit, 0 offset
 Data Range: 0 to 8,031.875 rpm Operational Range: same as data range
 Type: Measured
 Supporting information:
 PGN 61442

SPN 233 Unit Number (Power Unit)

Owner assigned unit number for the power unit of the vehicle.

NOTE: The ASCII character "*" is reserved as a delimiter.

Data Length: Variable - up to 200 characters ("*" delimited)
 Resolution: ASCII, 0 offset
 Data Range: 0 to 255 per byte Operational Range: same as data range
 Type: Measured
 Supporting information:
 PGN 65259

SPN 234 Software Identification

Software identification of an electronic module. As an example, this parameter may be represented with ASCII characters MMDDYYaa where MM is the month, DD is the day, YY is the year, and aa is the revision number.

NOTE The ASCII character "*" is reserved as a delimiter.

Data Length: Variable - up to 200 characters ("*" delimited)
 Resolution: ASCII, 0 offset
 Data Range: 0 to 255 per byte Operational Range: same as data range
 Type: Measured
 Supporting information:
 PGN 65242

SPN 235 Engine Total Idle Hours

Accumulated time of operation of the engine while under idle conditions.

Data Length: 4 bytes
Resolution: 0.05 hr/bit, 0 offset
Data Range: 0 to 210,554,060.75 hr Operational Range: same as data range
Type: Measured
Supporting information:
PGN 65244

SPN 236 Engine Total Idle Fuel Used

Accumulated amount of fuel used during vehicle operation while under idle conditions.

Data Length: 4 bytes
Resolution: 0.5 L/bit, 0 offset
Data Range: 0 to 2,105,540,607.5 L Operational Range: same as data range
Type: Measured
Supporting information:
PGN 65244

SPN 237 Vehicle Identification Number

Vehicle Identification Number (VIN) as assigned by the vehicle manufacturer.

NOTE The ASCII character "*" is reserved as a delimiter.

Data Length: Variable - up to 200 characters ("*" delimited)
Resolution: ASCII, 0 offset
Data Range: 0 to 255 per byte Operational Range: same as data range
Type: Measured
Supporting information:
PGN 65260

SPN 241 Tire Pressure

Pressure at which air is contained in cavity formed by tire and rim.

Data Length: 1 byte
Resolution: 4 kPa/bit, 0 offset
Data Range: 0 to 1000 kPa Operational Range: same as data range
Type: Measured
Supporting information:
PGN 65268

SPN 242 **Tire Temperature**

Temperature at the surface of the tire sidewall.

Data Length: 2 bytes

Resolution: 0.03125 deg C/bit, -273 deg C offset

Data Range: -273 to 1735 deg C Operational Range: same as data range

Type: Measured

Supporting information:

PGN 65268

SPN 244 **Trip Distance**

Distance traveled during all or part of a journey.

NOTE See SPN 918 for alternate resolution.

Data Length: 4 bytes

Resolution: 0.125 km/bit, 0 offset

Data Range: 0 to 526,385,151.9 km Operational Range: same as data range

Type: Measured

Supporting information:

PGN 65248

SPN 245 **Total Vehicle Distance**

Accumulated distance traveled by vehicle during its operation.

NOTE See SPN 917 for alternate resolution.

Data Length: 4 bytes

Resolution: 0.125 km/bit, 0 offset

Data Range: 0 to 526,385,151.9 km Operational Range: same as data range

Type: Measured

Supporting information:

PGN 65248

SPN 246 **Total Vehicle Hours**

Accumulated time of operation of vehicle.

Data Length: 4 bytes

Resolution: 0.05 hr/bit, 0 offset

Data Range: 0 to 210,554,060.75 hr Operational Range: same as data range

Type: Measured

Supporting information:

PGN 65255

SPN 247 Engine Total Hours of Operation

Accumulated time of operation of engine.

Data Length: 4 bytes

Resolution: 0.05 hr/bit, 0 offset

Data Range: 0 to 210,554,060.75 hr Operational Range: same as data range

Type: Measured

Supporting information:

PGN 65253

SPN 248 Total Power Takeoff Hours

Accumulated time of operation of power takeoff device.

Data Length: 4 bytes

Resolution: 0.05 hr/bit, 0 offset

Data Range: 0 to 210,554,060.75 hr Operational Range: same as data range

Type: Measured

Supporting information:

PGN 65255

SPN 249 Engine Total Revolutions

Accumulated number of revolutions of engine crankshaft during its operation.

Data Length: 4 bytes

Resolution: 1000 r/bit, 0 offset

Data Range: 0 to 4,211,081,215,000 r Operational Range: same as data range

Type: Measured

Supporting information:

PGN 65253

SPN 250 Engine Total Fuel Used

Accumulated amount of fuel used during vehicle operation.

Data Length: 4 bytes

Resolution: 0.5 L/bit, 0 offset

Data Range: 0 to 2,105,540,607.5 L Operational Range: same as data range

Type: Measured

Supporting information:

PGN 65257

SPN 354 **Relative Humidity**

Measures humidity of combustion air prior to entry into turbocharger

Data Length: 1 byte

Resolution: 0.4 %/bit, 0 offset

Data Range: 0 to 100 % Operational Range: same as data range

Type: Measured

Supporting information:

PGN 65164

SPN 407 **Axle Group Full Weight Calibration**

The full weight calibration measurement of an axle group

Data Length: 2 bytes

Resolution: 2 kg/bit, 0 offset

Data Range: 0 to 128,510 kg Operational Range: same as data range

Type: Measured

Supporting information:

PGN 64873

SPN 408 **Axle Group Empty Weight Calibration**

The empty weight calibration measurement of an axle group

Data Length: 2 bytes

Resolution: 2 kg/bit, 0 offset

Data Range: 0 to 128,510 kg Operational Range: same as data range

Type: Measured

Supporting information:

PGN 64873

SPN 409 **Axle Group Weight**

Total mass imposed on the road surface by all the tires in the axle group

Data Length: 2 bytes

Resolution: 2 kg/bit, 0 offset

Data Range: 0 to 128,510 kg Operational Range: same as data range

Type: Measured

Supporting information:

PGN 64874

SPN 411 Engine Exhaust Gas Recirculation Differential Pressure

Differential pressure across the Exhaust Gas Recirculation (EGR) system

Data Length: 2 bytes

Resolution: 1/128 kPa/bit, -250 kPa offset

Data Range: -250 kPa TO 251.99 kPa Operational Range: same as data range

Type: Measured

Supporting information:

PGN 65188

SPN 412 Engine Exhaust Gas Recirculation Temperature

Temperature of Recirculated Exhaust Gas

Data Length: 2 bytes

Resolution: 0.03125 deg C/bit, -273 deg C offset

Data Range: -273 to 1735 deg C Operational Range: same as data range

Type: Measured

Supporting information:

PGN 65188

SPN 413 Net Vehicle Weight Change

Identifies the net vehicle weight change from the time of last vehicle net weight zeroing.

Data Length: 3 bytes

Resolution: 2 kg/bit, -16,449,535 offset

Data Range: -16,449,535 to 16,449,535 Operational Range: same as data range

Type: Measured

Supporting information:

PGN 64872

SPN 417 Gross Combination Weight

Total weight of the truck and all the trailers with on-board scales.

Data Length: 3 bytes

Resolution: 2 kg/bit, 0 offset

Data Range: 0 to 32,899,070 kg Operational Range: same as data range

Type: Measured

Supporting information:

PGN 64872

SPN 441 Auxiliary Temperature 1

Temperature measured by auxiliary temperature sensor #1. Not to be used in place of existing SPNs.

Data Length: 1 byte

Resolution: 1 deg C/bit, -40 deg C offset

Data Range: -40 to 210 deg C Operational Range: same as data range

Type: Measured

Supporting information:

PGN 65164

SPN 442 Auxiliary Temperature 2

Temperature measured by auxiliary temperature sensor #2. Not to be used in place of existing SPNs.

Data Length: 1 byte

Resolution: 1 deg C/bit, -40 deg C offset

Data Range: -40 to 210 deg C Operational Range: same as data range

Type: Measured

Supporting information:

PGN 65164

SPN 444 Battery Potential / Power Input 2

This parameter measures the second source of battery potential as measured at the input of the ECM/actuator etc. coming from one or more batteries, irrespective of the distance between the component and the battery. This SPN is also used when ECM's are interconnected in a series configuration, where the source of power is coming directly or indirectly from the same battery/batteries.

Data Length: 2 bytes

Resolution: 0.05 V/bit, 0 offset

Data Range: 0 to 3212.75 V Operational Range: same as data range

Type: Measured

Supporting information: See Appendix D - PGN 65104

PGN 65165

SPN 509 Milepost Identification

Used to identify the milepost as detected by a milepost sensor

Data Length: Variable - up to 100 characters

Resolution: ASCII, 0 offset

Data Range: 0 to 255 per byte Operational Range: same as data range

Type: Measured

Supporting information:

PGN 64959

SPN 512 *Driver's Demand Engine - Percent Torque*

The requested torque output of the engine by the driver. It is based on input from the following requestors external to the powertrain: operator (via the accelerator pedal), cruise control and/or road speed limit governor. Dynamic commands from internal powertrain functions such as smoke control, low- and high-speed engine governing; ASR and shift control are excluded from this calculation. The data is transmitted in indicated torque as a percent of the reference engine torque. See PGN 65251 for the engine configuration message. Several status bits are defined separately to indicate the request which is currently being honored. This parameter may be used for shift scheduling.

Data Length: 1 byte
 Resolution: 1 %/bit, -125 % offset
 Data Range: -125 to 125 % Operational Range: 0 to 125%
 Type: Measured
 Supporting information: See Appendix D - SPN 512
 PGN 61444

SPN 513 *Actual Engine - Percent Torque*

The calculated output torque of the engine. The data is transmitted in indicated torque as a percent of reference engine torque (see the engine configuration message, PGN 65251). The engine percent torque value will not be less than zero and it includes the torque developed in the cylinders required to overcome friction.

Data Length: 1 byte
 Resolution: 1 %/bit, -125 % offset
 Data Range: -125 to 125 % Operational Range: 0 to 125%
 Type: Measured
 Supporting information:
 PGN 61444

SPN 514 *Nominal Friction - Percent Torque*

The calculated torque that indicates the amount of torque required by the basic engine itself added by the loss torque of accessories. It contains the frictional and thermodynamic loss of the engine itself, and the losses of fuel, oil and cooling pumps. The data is transmitted in indicated torque as a percent of reference engine torque (see the engine configuration message, PGN 65251).

The realization can be done by a map dependent on engine speed and engine temperature and an offset value for additional loss torques.

See SPN 2978 for an indicator that describes the possible inclusion of engine parasitic losses such as cooling fan, etc. in this parameter value.

Data Length: 1 byte
 Resolution: 1 %/bit, -125 % offset
 Data Range: -125 to 125 % Operational Range: same as data range
 Type: Status
 Supporting information:
 PGN 65247

SPN 515 Engine's Desired Operating Speed

An indication by the engine of the optimal operating speed of the engine for the current existing conditions. These conditions may include the torque generated to accommodate powertrain demands from the operator (via the accelerator pedal), cruise control, road speed limit governors, or ASR. Dynamic commands from functions such as smoke control or shift control are excluded from this calculation.

Data Length: 2 bytes
 Resolution: 0.125 rpm/bit, 0 offset
 Data Range: 0 to 8,031.875 rpm Operational Range: (upper byte resolution = 32 rpm/bit)
 Type: Status
 Supporting information:
 PGN 65247

SPN 517 Navigation-Based Vehicle Speed

Speed of the vehicle as calculated from a device such as a Global Positioning System (GPS).

Data Length: 2 bytes
 Resolution: 1/256 km/h per bit, 0 offset
 Data Range: 0 to 250.996 km/h Operational Range: same as data range
 Type: Measured
 Supporting information:
 PGN 65256

SPN 518 Engine Requested Torque/Torque Limit

Parameter provided to the engine or retarder in the torque/speed control message for controlling or limiting the output torque.

Requested torque to the engine is measured in indicated torque as a percentage of reference engine torque (see the engine configuration message, PGN 65251). This is the engine torque at which the engine is expected to operate if the torque control mode is active or the engine torque which the engine is not expected to exceed if the torque limit mode is active.

Zero torque can be requested which implies zero fuel and, according to Figures SPN512_A and SPN512_B, the engine will not be allowed to stall. The actual engine percent torque (SPN 513) should be zero and the engine should decelerate until the low idle governor kicks in, at which time the actual engine percent torque will be calculated as shown in Figures SPN512_A and SPN512_B and the engine torque mode bits (SPN 899) should be equal to 0000b - Low Idle Governor.

Requested torque to the retarder is measured in indicated torque as a percentage of reference retarder torque (see the retarder configuration message, PGN 65249). The logic used in enabling or disabling the retarder is based on the override control mode priority bits (SPN 897).

A zero torque request to the retarder is a disable request, and is used by a J1939 node to prevent the retarder from being activated by other combinations of inputs outside of J1939 commands. The Torque Limit Mode is commonly used for this purpose.

Data Length: 1 byte
 Resolution: 1 %/bit, -125 % offset
 Data Range: -125 to 125 % Operational Range: 0 to 125% engine torque requests, -125% to 0% for retarder torque requests
 Type: Status
 Supporting information: See Appendix D - SPN 518
 PGN 0

SPN 519 Engine's Desired Operating Speed Asymmetry Adjustment

This byte is utilized in transmission gear selection routines and indicates the engine's preference of lower versus higher engine speeds should its desired speed not be achievable. This is a scaled ratio such that 125 represents an equal preference for a speed lower or higher than the engine's indicated desired speed. The higher the asymmetry adjustment value is above 125, the more the engine prefers to be operated at or above its indicated desired speed. Conversely, the lower the asymmetry adjustment value is below 125, the more the engine prefers to operate at or below its indicated desired speed. Typically, the engine's asymmetry adjustment will be predicated on fuel consumption considerations, and under these conditions, the method for computing the asymmetry adjustment is indicated in Figure SPN519_A. The engine may include other factors into its asymmetry adjustment calculation such as temperatures, pressures, and other operating parameters.

Data Length: 1 byte
 Resolution: 1/bit, 0 offset
 Data Range: 0 to 250 Operational Range: same as data range
 Type: Status
 Supporting information: See Appendix D - SPN 519
 PGN 65247

SPN 520 Actual Retarder - Percent Torque

Actual braking torque of the retarder as a percent of retarder configuration reference torque SPN 556.

Data Length: 1 byte
 Resolution: 1 %/bit, -125 % offset
 Data Range: -125 to 125 % Operational Range: -125% to 0 %
 Type: Measured
 Supporting information:
 PGN 61440

SPN 521 Brake Pedal Position

Ratio of brake pedal position to maximum pedal position. Used for electric brake applications. 0% means no braking. Also when there are two brake pedals on the machine (Left Brake Pedal Position SPN 3033 and Right Brake Pedal Position SPN 3032) the maximum of the two should be transmitted for Brake Pedal Position.

Data Length: 1 byte
 Resolution: 0.4 %/bit, 0 offset
 Data Range: 0 to 100 % Operational Range: same as data range
 Type: Measured
 Supporting information:
 PGN 61441

SPN 522 Percent Clutch Slip

Parameter which represents the ratio of input shaft speed to current engine speed (in percent).

Percent Clutch Slip = $((\text{Engine rpm} - \text{Input shaft rpm}) / (\text{Engine rpm})) \times 100$

Data Length: 1 byte
 Resolution: 0.4 %/bit, 0 offset
 Data Range: 0 to 100 % Operational Range: same as data range
 Type: Measured
 Supporting information:
 PGN 61442

SPN 523 *Transmission Current Gear*

The gear currently engaged in the transmission or the last gear engaged while the transmission is in the process of shifting to the new or selected gear. Transitions toward a destination gear will not be indicated. Once the selected gear has been engaged then Transmission Current Gear (SPN 525) will reflect that gear.

Data Length: 1 byte

Resolution: 1 gear value/bit, -125 offset

Data Range: -125 to 125

Operational Range: -125 to +125, negative values are reverse gears, positive values are forward gears, zero is neutral. 251 (0xFB) is park.

Type: Measured

Supporting information:

PGN 61445

SPN 524 *Transmission Selected Gear*

The gear that the transmission will attempt to achieve during the current shift if a shift is in progress, or the next shift if one is pending (i.e., waiting for torque reduction to initiate the shift).

Data Length: 1 byte

Resolution: 1 gear value/bit, -125 offset

Data Range: -125 to 125

Operational Range: -125 to +125, negative values are reverse gears, positive values are forward gears, zero is neutral. 251 (0xFB) is park.

Type: Status

Supporting information:

PGN 61445

SPN 525 Transmission Requested Gear

Gear requested by the operator, ABS, or engine.

Negative values are reverse gears, positive values are forward gears, zero is neutral, parameter specific indicators are listed below.

Parameter specific values for this parameter are as follows:

0xFD (253 dec) = Hold current gear
 0xFC (252 dec) = Forward Drive Position
 0xFB (251 dec) = 'Park' position
 0xFA (250 dec) = Forward 'Low' position
 0xF9 (249 dec) = Upshift 1 gear from current position
 0xF8 (248 dec) = Upshift 2 gears from current position
 0xF7 (247 dec) = Downshift 1 gear from current position
 0xF6 (246 dec) = Downshift 2 gears from current position
 0xF5 (245 dec) = D-1: 1st forward selector position referenced from 'Drive'
 0xF4 (244 dec) = D-2: 2nd forward selector position referenced from 'Drive'
 0xF3 (243 dec) = D-3: 3rd forward selector position referenced from 'Drive'
 0xF2 (242 dec) = D-4: 4th forward selector position referenced from 'Drive'
 0xF1 (241 dec) = D-5: 5th forward selector position referenced from 'Drive'
 0xF0 (240 dec) = D-6: 6th forward selector position referenced from 'Drive'
 0xEF (239 dec) = D-7: 7th forward selector position referenced from 'Drive'
 0xEE (238 dec) = Between two shift selector positions (if detail is unknown)
 0xED (237 dec) = Between two reverse shift selector positions
 0xEC (236 dec) = Between two forward shift selector positions
 0xEB (235 dec) = Between D-7 and D-6 shift selector positions
 0xEA (234 dec) = Between D-6 and D-5 shift selector positions
 0xE9 (233 dec) = Between D-5 and D-4 shift selector positions
 0xE8 (232 dec) = Between D-4 and D-3 shift selector positions
 0xE7 (231 dec) = Between D-3 and D-2 shift selector positions
 0xE6 (230 dec) = Between D-2 and D-1 shift selector positions
 0xE5 (229 dec) = Between D-1 and 'Drive' shift selector positions
 0xE4 (228 dec) = Between 'Drive' and 'Neutral' shift selector positions
 0xE3 (227 dec) = Between 'Neutral' and 'Reverse' shift selector positions
 0xE2 (226 dec) = Between 'Reverse' and 'Park' shift selector positions
 0xE1 (225 dec) = Press of momentary button to reselect current position
 0xE0 (224 dec) = Position unknown and/or no buttons pressed
 0xDF (223 dec) = Reverse Selector Position

0xDE - 0xBE (222 dec - 190 dec) = Reserved

0x3C - 0x00 (60 dec - 0 dec) = Reserved

Forward selector position from drive (0xF5 to 0xEF) – Indicates shift selector position in reference to the 'Drive' position on the selector. It is possible that the shift selector software may not know the number of forward ranges. The shift selector may identify the position selected by the operator while the transmission ECU determines what range or gear that represents. If there is a digital display, the transmission ECU would communicate what is to be displayed via another message such as ETC#2 or ETC#7.

For example: Consider a vehicle with a 5-speed automatic transmission with the shift lever on the column. Suppose that shift selector has a limited number of positions, such that having positions for D-4-3-2-1 is not an option. For this example, assume there are only have enough lever positions for D-3-2-1. Pulling the lever into "D" will put the transmission in 5th (highest gear). It is desired that pulling the lever to the physical "3" position will limit the transmission to a maximum range of 3rd gear.

When the selector is pulled down into "3", the shifter selector itself has no way of correlating this physical lever position to the desired gear; it would have to be calibrated with software to tell it this information. If not calibrated, the shift selector cannot directly command the transmission to go to 3rd gear; it only knows it's one notch below drive.

However, if "D-1" (lever position, as opposed to desired gear) is broadcast by the selector, the transmission ECU can receive this and then make the determination of what range is desired. The benefit is that no specific calibration of the shift selector is required.

Between selector positions (0xEE to 0xE2) – Indicates the shift selector is not in an appropriate position. If a lever-type shift selector with a mechanical display is stuck between detents, it may appear to the operator that it is in the desired position when in fact it is not. The shift selector may be capable of reporting only that it is between positions or that it is between forward or reverse positions. If known, the transmission ECU may respond differently depending on which positions are involved.

Reselect current position (0xE1) - If the TC1 message continues to send the position last selected, then a capability to reselect the same position is required. For example: If a 'Neutral to Drive' shift is selected and that shift is inhibited (say

for high engine speed), it may be necessary for the operator to reselect 'Drive' after the inhibit conditions pass in order for the transmission ECU to honor the request.

Position unknown and/or no buttons pressed (0xE0) - A push-button style shift selector with momentary contact buttons may send this indicator after initialization before any buttons are pressed, or before the transmission ECU determines and communicates the initial selection. This indicator could also be sent between button presses as an alternative to sending the last button press.

Data Length: 1 byte
 Resolution: 1 gear value/bit, -125 offset
 Data Range: -125 to 125 Operational Range: -64 to 64
 Type: Status
 Supporting information:
 PGN 256

SPN 526 *Transmission Actual Gear Ratio*

Actual ratio of input shaft speed to output shaft speed.

Data Length: 2 bytes
 Resolution: 0.001/bit, 0 offset
 Data Range: 0 to 64.255 Operational Range: same as data range
 Type: Measured
 Supporting information:
 PGN 61445

SPN 527 *Cruise Control States*

This parameter is used to indicate the current state, or mode, of operation by the cruise control device. This is a status parameter.

000 - Off/Disabled
 001 - Hold
 010 - Accelerate
 011 - Decelerate
 100 - Resume
 101 - Set
 110 - Accelerator Override
 111 - Not available

Data Length: 3 bits
 Resolution: 8 states/3 bit, 0 offset
 Data Range: 0 to 7 Operational Range: same as data range
 Type: Status
 Supporting information: See Appendix D - SPN 527
 PGN 65265

SPN 528 Engine Speed At Point 2 (Engine Configuration)

Engine speed of point 2 of the engine torque map (see PGN 65251 and supporting document). In engine configuration mode 1 and 3, point 2 is defined as the kick-in point from which torque is reduced to zero. In mode 2 (see Table PGN65251_A), there are no special requirements for the definition of this point.

Data Length: 2 bytes
Resolution: 0.125 rpm/bit, 0 offset
Data Range: 0 to 8,031.875 rpm Operational Range: same as data range
Type: Measured
Supporting information:
PGN 65251

SPN 529 Engine Speed At Point 3 (Engine Configuration)

Engine speed of point 3, 4, and 5 of the engine torque map (see PGN 65251 and supporting document). It is recommended that one of these points indicate the peak torque point for the current engine torque map. Points 3, 4, and 5 are optional and lie between idle and point 2.

Data Length: 2 bytes
Resolution: 0.125 rpm/bit, 0 offset
Data Range: 0 to 8,031.875 rpm Operational Range: same as data range
Type: Measured
Supporting information:
PGN 65251

SPN 530 Engine Speed At Point 4 (Engine Configuration)

Engine speed of point 3, 4, and 5 of the engine torque map (see PGN 65251 and supporting document). It is recommended that one of these points indicate the peak torque point for the current engine torque map. Points 3, 4, and 5 are optional and lie between idle and point 2.

Data Length: 2 bytes
Resolution: 0.125 rpm/bit, 0 offset
Data Range: 0 to 8,031.875 rpm Operational Range: same as data range
Type: Measured
Supporting information:
PGN 65251

SPN 531 Engine Speed At Point 5 (Engine Configuration)

Engine speed of point 3, 4, and 5 of the engine torque map (see PGN 65251 and supporting document). It is recommended that one of these points indicate the peak torque point for the current engine torque map. Points 3, 4, and 5 are optional and lie between idle and point 2.

Data Length: 2 bytes
Resolution: 0.125 rpm/bit, 0 offset
Data Range: 0 to 8,031.875 rpm Operational Range: same as data range
Type: Measured
Supporting information:
PGN 65251

SPN 532 Engine Speed At High Idle, Point 6 (Engine Configuration)

Engine speed of high idle (point 6) of the engine torque map (see PGN 65251 and supporting document). In engine configuration mode 3 (see Figure PGN65251_C), point 6 is not defined by the engine torque map but by the governor characteristic and the zero torque line.

Data Length: 2 bytes
 Resolution: 0.125 rpm/bit, 0 offset
 Data Range: 0 to 8,031.875 rpm Operational Range: same as data range
 Type: Measured
 Supporting information:
 PGN 65251

SPN 533 Engine Maximum Momentary Override Speed, Point 7 (Engine Configuration)

The maximum engine speed above high idle allowed by the engine control during a momentary high idle override. This duration of the override is limited by the maximum momentary override time limit, SPN 534.

Data Length: 2 bytes
 Resolution: 0.125 rpm/bit, 0 offset
 Data Range: 0 to 8,031.875 rpm Operational Range: same as data range
 Type: Measured
 Supporting information:
 PGN 65251

SPN 534 Engine Maximum Momentary Override Time Limit (Engine Configuration)

The maximum time limit allowed to override the engine's high idle speed.

Data Length: 1 byte
 Resolution: 0.1 s/bit, 0 offset
 Data Range: 0 to 25 s Operational Range: 0 to 25 sec, 0 = no override of high idle allowed, 255 = not applicable (no time restriction)
 Type: Measured
 Supporting information:
 PGN 65251

SPN 535 Engine Requested Speed Control Range Lower Limit (Engine Configuration)

The minimum engine speed that the engine will allow when operating in a speed control/limit mode.

Data Length: 1 byte
 Resolution: 10 rpm/bit, 0 offset
 Data Range: 0 to 2,500 rpm Operational Range: same as data range
 Type: Measured
 Supporting information:
 PGN 65251

SPN 536 Engine Requested Speed Control Range Upper Limit (Engine Configuration)

The maximum engine speed regardless of load that the engine will allow when operating in a speed control/limit mode, excluding any maximum momentary engine override speed, if supported.

Data Length: 1 byte
Resolution: 10 rpm/bit, 0 offset
Data Range: 0 to 2,500 rpm Operational Range: same as data range
Type: Measured
Supporting information:
PGN 65251

SPN 537 Engine Requested Torque Control Range Lower Limit (Engine Configuration)

The minimum engine torque that the engine will allow when operating in a torque control/limit mode.

Data Length: 1 byte
Resolution: 1 %/bit, -125 % offset
Data Range: -125 to 125 % Operational Range: 0 to 125%
Type: Measured
Supporting information:
PGN 65251

SPN 538 Engine Requested Torque Control Range Upper Limit (Engine Configuration)

The maximum engine torque that the engine will allow when operating in a torque control/limit mode.

Data Length: 1 byte
Resolution: 1 %/bit, -125 % offset
Data Range: -125 to 125 % Operational Range: 0 to 125%
Type: Measured
Supporting information:
PGN 65251

SPN 539 Engine Percent Torque At Idle, Point 1 (Engine Configuration)

The torque limit that indicates the available engine torque which can be provided by the engine at idle speed. This parameter may be influenced by engine temperature (after power up) and other stationary changes (calibration offsets, sensor failures, etc.) See also SPN 188. The data is transmitted in indicated torque as a percent of the reference engine torque.

Data Length: 1 byte
Resolution: 1 %/bit, -125 % offset
Data Range: -125 to 125 % Operational Range: 0 to 125%
Type: Measured
Supporting information:
PGN 65251

SPN 540 Engine Percent Torque At Point 2 (Engine Configuration)

The torque limit that indicates the available engine torque which can be provided by the engine at point 2 of the engine map (see PGN 65251 and supporting documents). In engine configuration mode 1 and 3 (see Table PGN65251_A see PGN 65251), point 2 is defined as the kick-in point from which torque is reduced to zero. In mode 2, there are no special requirements for the definition of this point. The data is transmitted in indicated torque as a percent of the reference engine torque.

Data Length: 1 byte
 Resolution: 1 %/bit, -125 % offset
 Data Range: -125 to 125 % Operational Range: 0 to 125%
 Type: Measured
 Supporting information:
 PGN 65251

SPN 541 Engine Percent Torque At Point 3 (Engine Configuration)

The torque limit that indicates the available engine torque which can be provided by the engine at point 3, 4, and 5 of the engine map (see PGN 65251 and supporting documents).. It is required that one of these points indicate the peak torque point for the current engine torque map. Points 3, 4, and 5 lie between idle and point 2. The data is transmitted in indicated torque as a percent of the reference engine torque.

Data Length: 1 byte
 Resolution: 1 %/bit, -125 % offset
 Data Range: -125 to 125 % Operational Range: 0 to 125%
 Type: Measured
 Supporting information:
 PGN 65251

SPN 542 Engine Percent Torque At Point 4 (Engine Configuration)

The torque limit that indicates the available engine torque which can be provided by the engine at point 3, 4, and 5 of the engine map (see PGN 65251 and supporting documents). It is required that one of these points indicate the peak torque point for the current engine torque map. Points 3, 4, and 5 lie between idle and point 2. The data is transmitted in indicated torque as a percent of the reference engine torque.

Data Length: 1 byte
 Resolution: 1 %/bit, -125 % offset
 Data Range: -125 to 125 % Operational Range: 0 to 125%
 Type: Measured
 Supporting information:
 PGN 65251

SPN 543 Engine Percent Torque At Point 5 (Engine Configuration)

The torque limit that indicates the available engine torque which can be provided by the engine at point 3, 4, and 5 of the engine map (see PGN 65251 and supporting documents). It is required that one of these points indicate the peak torque point for the current engine torque map. Points 3, 4, and 5 lie between idle and point 2. The data is transmitted in indicated torque as a percent of the reference engine torque.

Data Length: 1 byte
 Resolution: 1 %/bit, -125 % offset
 Data Range: -125 to 125 % Operational Range: 0 to 125%
 Type: Measured
 Supporting information:
 PGN 65251

SPN 544 Engine Reference Torque (Engine Configuration)

This parameter is the 100% reference value for all defined indicated engine torque parameters. It is only defined once and doesn't change if a different engine torque map becomes valid.

Data Length: 2 bytes
 Resolution: 1 Nm/bit, 0 offset
 Data Range: 0 to 64,255 Nm Operational Range: same as data range
 Type: Measured
 Supporting information:
 PGN 65251

SPN 545 Engine Gain (Kp) Of The Endspped Governor (Engine Configuration)

The endspped governor is defined as a linear line with the following equations (Capital letters mean physical values, small letters mean normalized values). Refer to Figures PGN65251_A and PGN65251_B.

The gain KP/kp is defined as a positive value. The factor 4096 is necessary for realizing flat curves with sufficient resolution as well as very steep curves.

$KP = \text{delta Torque} / \text{delta Speed}$
 $kp \text{ (normalized)} = KP * 250/100\% * 8031 \text{ rpm}/64255 * 4096 = KP * 1280 \text{ rpm}/\%$

Data Length: 2 bytes
 Resolution: 1/1280 %/rpm per bit, 0 offset
 Data Range: 0 to 50.2 %/rpm Operational Range: same as data range
 Type: Measured
 Supporting information:
 PGN 65251

SPN 546 Retarder Speed At Idle, Point 1 (Retarder Configuration)

Please reference PGN 65249

Data Length: 2 bytes
 Resolution: 0.125 rpm/bit, 0 offset
 Data Range: 0 to 8,031.875 rpm Operational Range: same as data range
 Type: Measured
 Supporting information:
 PGN 65249

SPN 547 Retarder Speed At Peak Torque, Point 5 (Retarder Configuration)

Please reference PGN 65249

Data Length: 2 bytes
 Resolution: 0.125 rpm/bit, 0 offset
 Data Range: 0 to 8,031.875 rpm Operational Range: same as data range
 Type: Measured
 Supporting information:
 PGN 65249

SPN 548 *Maximum Retarder Speed, Point 2 (Retarder Configuration)*

Maximum speed of retarder (Please reference PGN 65249).

Data Length: 2 bytes

Resolution: 0.125 rpm/bit, 0 offset

Data Range: 0 to 8,031.875 rpm Operational Range: same as data range

Type: Measured

Supporting information:

PGN 65249

SPN 549 *Retarder Speed At Point 3 (Retarder Configuration)*

Retarder speed of point 3 of the engine retarder torque map. Please reference PGN 65249.

Data Length: 2 bytes

Resolution: 0.125 rpm/bit, 0 offset

Data Range: 0 to 8,031.875 rpm Operational Range: same as data range

Type: Measured

Supporting information:

PGN 65249

SPN 550 *Retarder Speed At Point 4 (Retarder Configuration)*

Retarder speed of point 4 of the engine retarder torque map. Please reference PGN 65249.

Data Length: 2 bytes

Resolution: 0.125 rpm/bit, 0 offset

Data Range: 0 to 8,031.875 rpm Operational Range: same as data range

Type: Measured

Supporting information:

PGN 65249

SPN 551 *Percent Torque At Idle, Point 1 (Retarder Configuration)*

The torque limit that indicates the available retarder torque which can be provided by the retarder at idle speed. The data is transmitted in indicated torque as a percent of the reference retarder torque.

Data Length: 1 byte

Resolution: 1 %/bit, -125 % offset

Data Range: -125 to 125 % Operational Range: -125 to 0%

Type: Measured

Supporting information:

PGN 65249

SPN 552 Percent Torque At Maximum Speed, Point 2 (Retarder Configuration)

The torque limit that indicates the available retarder torque which can be provided by the retarder at its maximum speed. Please reference PGN 65249. The data is transmitted in indicated torque as a percent of the reference retarder torque.

Data Length: 1 byte
Resolution: 1 %/bit, -125 % offset
Data Range: -125 to 125 % Operational Range: -125 to 0%
Type: Measured
Supporting information:
PGN 65249

SPN 553 Percent Torque At Point 3 (Retarder Configuration)

The torque limit that indicates the available retarder torque which can be provided by the retarder at points 3 and 4 of the retarder torque map. Please reference PGN 65249. The data is transmitted in indicated torque as a percent of the reference retarder torque.

Data Length: 1 byte
Resolution: 1 %/bit, -125 % offset
Data Range: -125 to 125 % Operational Range: -125 to 0%
Type: Measured
Supporting information:
PGN 65249

SPN 554 Percent Torque At Point 4 (Retarder Configuration)

The torque limit that indicates the available retarder torque which can be provided by the retarder at points 3 and 4 of the retarder torque map. Please reference PGN 65249. The data is transmitted in indicated torque as a percent of the reference retarder torque.

Data Length: 1 byte
Resolution: 1 %/bit, -125 % offset
Data Range: -125 to 125 % Operational Range: -125 to 0%
Type: Measured
Supporting information:
PGN 65249

SPN 555 Percent Torque At Peak Torque, Point 5 (Retarder Configuration)

The torque limit that indicates the available retarder torque which can be provided by the retarder at point 5 of the retarder torque map. Please reference PGN 65249. The data is transmitted in indicated torque as a percent of the reference retarder torque.

Data Length: 1 byte
Resolution: 1 %/bit, -125 % offset
Data Range: -125 to 125 % Operational Range: -125 to 0%
Type: Measured
Supporting information:
PGN 65249

SPN 556 Reference Retarder Torque (Retarder Configuration)

This parameter is the 100% reference value for all defined indicated retarder torque parameters. It is only defined once and doesn't change if a different retarder torque map becomes valid.

Data Length: 2 bytes
 Resolution: 1 Nm/bit, 0 offset
 Data Range: 0 to 64,255 Nm Operational Range: same as data range
 Type: Measured
 Supporting information:
 PGN 65249

SPN 557 Retarder Control Method (Retarder Configuration)

This parameter identifies the number of steps used by the retarder.

Data Length: 1 byte
 Resolution: 1 step/bit, 0 offset
 Data Range: 0 to 250 steps Operational Range: 0: continuous control, 1 On/Off control, 2 to 250: Number of steps
 Type: Measured
 Supporting information:
 PGN 65249

SPN 558 Accelerator Pedal 1 Low Idle Switch

Switch signal which indicates the state of the accelerator pedal 1 low idle switch. The low idle switch is defined in SAE Recommended Practice J1843.

00 - Accelerator pedal 1 not in low idle condition
 01 - Accelerator pedal 1 in low idle condition
 10 - Error
 11 - Not available

Data Length: 2 bits
 Resolution: 4 states/2 bit, 0 offset
 Data Range: 0 to 3 Operational Range: same as data range
 Type: Measured
 Supporting information:
 PGN 61443

SPN 559 Accelerator Pedal Kickdown Switch

Switch signal which indicates whether the accelerator pedal kickdown switch is opened or closed. The kickdown switch is defined in SAE J1843.

00 - Kickdown passive
 01 - Kickdown active
 10 - Error
 11 - Not available

Data Length: 2 bits
 Resolution: 4 states/2 bit, 0 offset
 Data Range: 0 to 3 Operational Range: same as data range
 Type: Measured
 Supporting information:
 PGN 61443

SPN 560 *Transmission Driveline Engaged*

Driveline engaged indicates the transmission controlled portion of the driveline is engaged sufficiently to allow a transfer of torque through the transmission. Driveline engaged is ACTIVE whenever the transmission is in gear and the clutch (if controlled by the transmission controller) is less than 100% clutch slip (clutch able to transfer torque). This parameter should be used in conjunction with the parameter "Shift in Process" (SPN 574). While a shift is in process, the receiver should not assume that the driveline is either fully engaged or disengaged (i.e., cruise control).

00 - Driveline disengaged
 01 - Driveline engaged
 10 - Error
 11 - Not available

Data Length: 2 bits
 Resolution: 4 states/2 bit, 0 offset
 Data Range: 0 to 3 Operational Range: same as data range
 Type: Measured
 Supporting information:
 PGN 61442

SPN 561 *ASR Engine Control Active*

State signal which indicates that ASR engine control has been commanded to be active. Active means that ASR actually tries to control the engine. This state signal is independent of other control commands to the engine (e.g., from the transmission) which may have higher priority.

00 - ASR engine control passive but installed
 01 - ASR engine control active
 10 - Reserved
 11 - Not available

Data Length: 2 bits
 Resolution: 4 states/2 bit, 0 offset
 Data Range: 0 to 3 Operational Range: same as data range
 Type: Status
 Supporting information:
 PGN 61441

SPN 562 *ASR Brake Control Active*

State signal which indicates that ASR brake control is active. Active means that ASR actually controls wheel brake pressure at one or more wheels of the driven axle(s).

00 - ASR brake control passive but installed
 01 - ASR brake control active
 10 - Reserved
 11 - Not available

Data Length: 2 bits
 Resolution: 4 states/2 bit, 0 offset
 Data Range: 0 to 3 Operational Range: same as data range
 Type: Status
 Supporting information:
 PGN 61441

SPN 563 *Anti-Lock Braking (ABS) Active*

State signal which indicates that the ABS is active. The signal is set active when wheel brake pressure actually starts to be modulated by ABS and is reset to passive when all wheels are in a stable condition for a certain time. The signal can also be set active when driven wheels are in high slip (e.g., caused by retarder). Whenever the ABS system is not fully operational (due to a defect or during off-road ABS operation), this signal is only valid for that part of the system that is still working. When ABS is switched off completely, the flag is set to passive regardless of the current wheel slip conditions.

00 - ABS passive but installed
01 - ABS active
10 - Reserved
11 - Not available

Data Length: 2 bits
Resolution: 4 states/2 bit, 0 offset
Data Range: 0 to 3 Operational Range: same as data range
Type: Status
Supporting information:
PGN 61441

SPN 564 *Differential Lock State - Central*

State used which indicates the condition of the central differential lock. The differential locks are located as defined in attached figure SPN564_A.

00 Differential lock disengaged
01 Differential lock engaged
10 Error
11 Not available

Data Length: 2 bits
Resolution: 4 states/2 bit, 0 offset
Data Range: 0 to 3 Operational Range: same as data range
Type: Status
Supporting information: See Appendix D - SPN 564
PGN 61446

SPN 565 *Differential Lock State - Central Front*

State used which indicates the condition of the central front differential lock. The differential locks are located as defined in figure SPN564_A.

00 Differential lock disengaged
01 Differential lock engaged
10 Error
11 Not available

Data Length: 2 bits
Resolution: 4 states/2 bit, 0 offset
Data Range: 0 to 3 Operational Range: same as data range
Type: Status
Supporting information:
PGN 61446

SPN 566 **Differential Lock State - Central Rear**

State used which indicates the condition of the central rear differential lock. The differential locks are located as defined in figure SPN564_A.

00 Differential lock disengaged
01 Differential lock engaged
10 Error
11 Not available

Data Length: 2 bits
Resolution: 4 states/2 bit, 0 offset
Data Range: 0 to 3 Operational Range: same as data range
Type: Status
Supporting information:
PGN 61446

SPN 567 **Differential Lock State - Front Axle 1**

State used which indicates the condition of the front axle 1 differential lock. The differential locks are located as defined in figure SPN564_A.

00 Differential lock disengaged
01 Differential lock engaged
10 Error
11 Not available

Data Length: 2 bits
Resolution: 4 states/2 bit, 0 offset
Data Range: 0 to 3 Operational Range: same as data range
Type: Status
Supporting information:
PGN 61446

SPN 568 **Differential Lock State - Front Axle 2**

State used which indicates the condition of the front axle 2 differential lock. The differential locks are located as defined in figure SPN 564_A.

00 Differential lock disengaged
01 Differential lock engaged
10 Error
11 Not available

Data Length: 2 bits
Resolution: 4 states/2 bit, 0 offset
Data Range: 0 to 3 Operational Range: same as data range
Type: Status
Supporting information:
PGN 61446

SPN 569 Differential Lock State - Rear Axle 1

State used which indicates the condition of the rear axle 1 differential lock. The differential locks are located as defined in figure SPN 564_A.

00 Differential lock disengaged
 01 Differential lock engaged
 10 Error
 11 Not available

Data Length: 2 bits
 Resolution: 4 states/2 bit, 0 offset
 Data Range: 0 to 3 Operational Range: same as data range
 Type: Status
 Supporting information:
 PGN 61446

SPN 570 Differential Lock State - Rear Axle 2

State used which indicates the condition of the rear axle 2 differential lock. The differential locks are located as defined in figure SPN 564_A.

00 Differential lock disengaged
 01 Differential lock engaged
 10 Error
 11 Not available

Data Length: 2 bits
 Resolution: 4 states/2 bit, 0 offset
 Data Range: 0 to 3 Operational Range: same as data range
 Type: Status
 Supporting information:
 PGN 61446

SPN 571 Retarder Enable - Brake Assist Switch

Switch signal which indicates whether the operator wishes the retarder to be enabled for vehicle braking assist. The retarder does not check this switch, nor does the enabling of this switch engage the retarder. When this switch is "enabled," the devices constructing TSC1 – destination retarder messages may command retarder torque for braking. For example, the cruise control should not request retarder torque if this switch is not "enabled." The switch exists to prevent the engine retarder from being asked to be engaged via TSC1 in a noise sensitive area. See also SPN 572

00 Retarder - brake assist disabled
 01 Retarder - brake assist enabled
 10 Error
 11 Not available

Data Length: 2 bits
 Resolution: 4 states/2 bit, 0 offset
 Data Range: 0 to 3 Operational Range: same as data range
 Type: Measured
 Supporting information:
 PGN 61440

SPN 572 **Retarder Enable - Shift Assist Switch**

Switch signal which indicates whether the operator wishes the retarder to be enabled for transmission shift assist. The retarder does not check this switch, nor does the enabling of this switch engage the retarder. When this switch is "enabled," the transmission may activate the retarder (via the TSC1 message) to increase the rate of engine deceleration to assist in shift control. The switch exists to prevent the engine retarder from being asked to be engaged via TSC1 in a noise sensitive area. See SPN 571.

00 Retarder - shift assist disabled
01 Retarder - shift assist enabled
10 Error
11 Not available

Data Length: 2 bits
Resolution: 4 states/2 bit, 0 offset
Data Range: 0 to 3 Operational Range: same as data range
Type: Measured
Supporting information:
PGN 61440

SPN 573 **Transmission Torque Converter Lockup Engaged**

State signal which indicates whether the torque converter lockup is engaged.

00 Torque converter lockup disengaged
01 Torque converter lockup engaged
10 Error
11 Not available

Data Length: 2 bits
Resolution: 4 states/2 bit, 0 offset
Data Range: 0 to 3 Operational Range: same as data range
Type: Status
Supporting information:
PGN 61442

SPN 574 **Transmission Shift In Process**

Indicates that the transmission is in process of shifting from the current gear to the selected gear. This state is generally ACTIVE during the entire time that the transmission controls the vehicle. This includes any transmission clutch control, all engine control sequences, pulling to transmission neutral, and engaging the destination gear (e.g., until it is no longer sending commands and/or limits to the engine). See also SPN 560. (See Figure SPN574_A)

00 - Shift is not in process
01 - Shift in process
10 - Error
11 - Not available

Data Length: 2 bits
Resolution: 4 states/2 bit, 0 offset
Data Range: 0 to 3 Operational Range: same as data range
Type: Measured
Supporting information: See Appendix D - SPN 574
PGN 61442

SPN 575 *ABS Off-road Switch*

Switch signal which indicates the position of the ABS off-road switch.

00 - ABS off-road switch passive
 01 - ABS off-road switch active
 10 - Error
 11 - Not available

Data Length: 2 bits
 Resolution: 4 states/2 bit, 0 offset
 Data Range: 0 to 3 Operational Range: same as data range
 Type: Measured
 Supporting information:
 PGN 61441

SPN 576 *ASR Off-road Switch*

Switch signal which indicates the position of the ASR off-road switch.

00 - ASR off-road switch passive
 01 - ASR off-road switch active
 10 - Error
 11 - Not available

Data Length: 2 bits
 Resolution: 4 states/2 bit, 0 offset
 Data Range: 0 to 3 Operational Range: same as data range
 Type: Measured
 Supporting information:
 PGN 61441

SPN 577 *ASR "Hill Holder" Switch*

Switch signal which indicates the position of the ASR "hill holder" switch.

00 - ASR "hill holder" switch passive
 01 - ASR "hill holder" switch active
 10 - Error
 11 - Not available

Data Length: 2 bits
 Resolution: 4 states/2 bit, 0 offset
 Data Range: 0 to 3 Operational Range: same as data range
 Type: Measured
 Supporting information:
 PGN 61441

SPN 578 **Drive Axle Temperature**

Temperature of axle lubricant in drive axle.

Data Length: 1 byte

Resolution: 1 deg C/bit, -40 deg C offset

Data Range: -40 to 210 deg C Operational Range: same as data range

Type: Measured

Supporting information:

PGN 65273

SPN 579 **Drive Axle Lift Air Pressure**

Gage pressure of air in system that utilizes compressed air to provide force between axle and frame.

Data Length: 1 byte

Resolution: 4 kPa/bit, 0 offset

Data Range: 0 to 1000 kPa Operational Range: same as data range

Type: Measured

Supporting information:

PGN 65273

SPN 580 **Altitude**

Altitude of the vehicle referenced to sea level at standard atmospheric pressure and temperature.

Data Length: 2 bytes

Resolution: 0.125 m/bit, -2500 m offset

Data Range: -2500 to 5531.875 m Operational Range: same as data range

Type: Measured

Supporting information:

PGN 65256

SPN 581 **Transmission Gear Ratio**

The transmission configuration describes the number of forward gears, the number of reverse gears, and the ratio of each gear with the following resolution.

Data Length: 2 bytes

Resolution: 0.001/bit, 0 offset

Data Range: 0 to 64.255 Operational Range: same as data range

Type: Measured

Supporting information:

PGN 65250

SPN 582 Axle Weight

Total mass imposed by the tires on the road surface at the specified axle.

Data Length: 2 bytes

Resolution: 0.5 kg/bit, 0 offset

Data Range: 0 to 32,127.5 kg Operational Range: same as data range

Type: Measured

Supporting information:

PGN 65258

SPN 583 Pitch

Pitch of the vehicle as calculated by the navigation device(s).

Data Length: 2 bytes

Resolution: 1/128 deg/bit, -200 deg offset

Data Range: -200 to 301.99 deg Operational Range: -200 deg (DECENT) to +301.992 deg (ASCENT)

Type: Measured

Supporting information:

PGN 65256

SPN 584 Latitude

Latitude position of the vehicle.

Data Length: 4 bytes

Resolution: 10^{-7} deg/bit, -210 deg offset

Data Range: -210 to 211.1008122 deg Operational Range: -210 deg (SOUTH) to +211.108122 deg (NORTH)

Type: Measured

Supporting information:

PGN 65267

SPN 585 Longitude

Longitude position of the vehicle.

Data Length: 4 bytes

Resolution: 10^{-7} deg/bit, -210 deg offset

Data Range: -210 to 211.1008122 deg Operational Range: -210 deg (WEST) to +211.108122 deg (EAST)

Type: Measured

Supporting information:

PGN 65267

SPN 586 (R) Make

Make of the component corresponding to the codes defined in the American Trucking Association Vehicle Maintenance Reporting Standard (ATA/VMRS).

Data Length: Variable - up to 5 characters ("*" delimited)
Resolution: ASCII, 0 offset
Data Range: 0 to 255 per byte Operational Range: same as data range
Type: Measured
Supporting information:
PGN 65259

SPN 587 Model

Model of the component.

NOTE - The ASCII character "*" is reserved as a delimiter.

Data Length: Variable - up to 200 characters ("*" delimited)
Resolution: ASCII, 0 offset
Data Range: 0 to 255 per byte Operational Range: same as data range
Type: Measured
Supporting information:
PGN 65259

SPN 588 Serial Number

Serial number of the component.

NOTE - The ASCII character "*" is reserved as a delimiter.

Data Length: Variable - up to 200 characters ("*" delimited)
Resolution: ASCII, 0 offset
Data Range: 0 to 255 per byte Operational Range: same as data range
Type: Measured
Supporting information:
PGN 65259

SPN 589 Alternator Speed

Actual rotation speed of the alternator.

Data Length: 2 bytes
Resolution: 0.5 rpm/bit, 0 offset
Data Range: 0 to 32,127.5 rpm Operational Range: same as data range
Type: Measured
Supporting information:
PGN 65237

SPN 590 Engine Idle Shutdown Timer State

Status signal which indicates the current mode of operation of the idle shutdown timer system. See Figure SPN590_A.

00 - Inactive
01 - Active
10 - Error
11 - Not available

Data Length: 2 bits
Resolution: 4 states/2 bit, 0 offset
Data Range: 0 to 3 Operational Range: same as data range
Type: Status
Supporting information: See Appendix D - SPN 590
PGN 65252

SPN 591 Engine Idle Shutdown Timer Function

Parameter which indicates the configuration of the idle shutdown timer system.

00 - Disabled in calibration
01 - Enabled in calibration
10 - Error
11 - Not available

Data Length: 2 bits
Resolution: 4 states/2 bit, 0 offset
Data Range: 0 to 3 Operational Range: same as data range
Type: Measured
Supporting information:
PGN 65252

SPN 592 Engine Idle Shutdown Timer Override

Status signal which indicates the status of the override feature of the idle shutdown timer system. See Figure SPN590_A.

00 - Inactive
01 - Active
10 - Error
11 - Not available

Data Length: 2 bits
Resolution: 4 states/2 bit, 0 offset
Data Range: 0 to 3 Operational Range: same as data range
Type: Status
Supporting information:
PGN 65252

SPN 593 Engine Idle Shutdown has Shutdown Engine

Status signal which identifies whether or not the engine has been shutdown by the idle shutdown timer system. See Figure SPN590_A.

00 - No
01 - Yes
10 - Error
11 - Not available

Data Length: 2 bits
Resolution: 4 states/2 bit, 0 offset
Data Range: 0 to 3 Operational Range: same as data range
Type: Status
Supporting information:
PGN 65252

SPN 594 Engine Idle Shutdown Driver Alert Mode

Status signal which indicates the status of the driver alert mode of the idle shutdown timer system. While the driver alert mode is active, the idle shutdown timer may be overridden. See Figure SPN590_A.

00 - Inactive
01 - Active
10 - Error
11 - Not available

Data Length: 2 bits
Resolution: 4 states/2 bit, 0 offset
Data Range: 0 to 3 Operational Range: same as data range
Type: Status
Supporting information:
PGN 65252

SPN 595 Cruise Control Active

Cruise control is switched on. It is not ensured that the engine is controlled by cruise control, as in the case of a large driver's demand the engine is controlled by the driver while cruise control is active (maximum selection of cruise control and driver's demand). The cruise control is set to 0 if a switch off condition occurs.

00 - Cruise control switched off
01 - Cruise control switched on
10 - Error
11 - Not available

Data Length: 2 bits
Resolution: 4 states/2 bit, 0 offset
Data Range: 0 to 3 Operational Range: same as data range
Type: Measured
Supporting information:
PGN 65265

SPN 596 Cruise Control Enable Switch

Switch signal which indicates that it is possible to manage the cruise control function.

00 - Cruise control disabled
01 - Cruise control enabled
10 - Error
11 - Not available

Data Length: 2 bits
Resolution: 4 states/2 bit, 0 offset
Data Range: 0 to 3 Operational Range: same as data range
Type: Measured
Supporting information:
PGN 65265

SPN 597 Brake Switch

Switch signal which indicates that the driver operated brake foot pedal is being pressed. This brake foot pedal is controlling the vehicles' service brake (total vehicle braking application, not park brakes). It is necessary for safe drivetrain behavior that the switch activates before the physical braking components are activated (i.e. Disengage the cruise control function prior to the activation of friction brakes).

00 - Brake pedal released
01 - Brake pedal depressed
10 - Error
11 - Not Available

Data Length: 2 bits
Resolution: 4 states/2 bit, 0 offset
Data Range: 0 to 3 Operational Range: same as data range
Type: Measured
Supporting information:
PGN 65265

SPN 598 Clutch Switch

Switch signal which indicates that the clutch pedal is being pressed. It is necessary for a safe drivetrain behavior that the clutch switch is set before the clutch is opened (cruise control function).

00 - Clutch pedal released
01 - Clutch pedal depressed
10 - Error
11 - Not available

Data Length: 2 bits
Resolution: 4 states/2 bit, 0 offset
Data Range: 0 to 3 Operational Range: same as data range
Type: Measured
Supporting information:
PGN 65265

SPN 599 **Cruise Control Set Switch**

Switch signal of the cruise control activator which indicates that the activator is in the position "set."

00 - Cruise control activator not in the position "set"
01 - Cruise control activator in position "set"
10 - Error
11 - Not available

Data Length: 2 bits
Resolution: 4 states/2 bit, 0 offset
Data Range: 0 to 3 Operational Range: same as data range
Type: Measured
Supporting information:
PGN 65265

SPN 600 **Cruise Control Coast (Decelerate) Switch**

Switch signal of the cruise control activator which indicates that the activator is in the position "coast (decelerate)."

00 - Cruise control activator not in the position "coast"
01 - Cruise control activator in position "coast"
10 - Error
11 - Not available

Data Length: 2 bits
Resolution: 4 states/2 bit, 0 offset
Data Range: 0 to 3 Operational Range: same as data range
Type: Measured
Supporting information:
PGN 65265

SPN 601 **Cruise Control Resume Switch**

Switch signal of the cruise control activator which indicates that the activator is in the position "resume."

00 - Cruise control activator not in the position "resume"
01 - Cruise control activator in position "resume"
10 - Error
11 - Not available

Data Length: 2 bits
Resolution: 4 states/2 bit, 0 offset
Data Range: 0 to 3 Operational Range: same as data range
Type: Measured
Supporting information:
PGN 65265

SPN 602 Cruise Control Accelerate Switch

Switch signal of the cruise control activator which indicates that the activator is in the position "accelerate."

00 - Cruise control activator not in the position "accelerate"
 01 - Cruise control activator in position "accelerate"
 10 - Error
 11 - Not available

Data Length: 2 bits
 Resolution: 4 states/2 bit, 0 offset
 Data Range: 0 to 3 Operational Range: same as data range
 Type: Measured
 Supporting information:
 PGN 65265

SPN 604 Transmission Neutral Switch

Identifies the status of the switch that indicates neutral.

00 - Off
 01 - On
 10 - Error
 11 - Not available

Data Length: 2 bits
 Resolution: 4 states/2 bit, 0 offset
 Data Range: 0 to 3 Operational Range: same as data range
 Type: Status
 Supporting information:
 PGN 65219

SPN 605 Refrigerant High Pressure Switch

Switch signal which indicates the position of the high pressure switch in the coolant circuit of an air conditioning system. When the switch is enabled, the pressure inside the circuit is too high and the compressor clutch may be disengaged.

00 - Pressure normal
 01 - Pressure too high, compressor clutch may be disengaged
 10 - Error
 11 - Not available

Data Length: 2 bits
 Resolution: 4 states/2 bit, 0 offset
 Data Range: 0 to 3 Operational Range: same as data range
 Type: Measured
 Supporting information:
 PGN 65252

SPN 606 Engine Momentary Overspeed Enable

Command signal used to indicate that the engine speed may be boosted up to the maximum engine overspeed value to accommodate transmission downshifts. The maximum time for overspeed is limited by the time defined in the engine configuration message (see PGN 65,251). The transmission module must command a "override disabled" state at least once before the engine will accept a subsequent request for overspeed.

00 Momentary engine overspeed is disabled
01 Momentary engine overspeed is enabled
10 Reserved
11 Take no action

Data Length: 2 bits
Resolution: 4 states/2 bit, 0 offset
Data Range: 0 to 3 Operational Range: same as data range
Type: Status
Supporting information:
PGN 61442

SPN 607 Progressive Shift Disable

Command signal used to indicate that progressive shifting by the engine should be disallowed.

00 Progressive shift is not disabled
01 Progressive shift is disabled
10 Reserved
11 Take no action

Data Length: 2 bits
Resolution: 4 states/2 bit, 0 offset
Data Range: 0 to 3 Operational Range: same as data range
Type: Status
Supporting information:
PGN 61442

SPN 619 Parking Brake Actuator

Signal which indicates the current state of the actuator(s) that control the parking brake (see also SPN 70).

00 - Parking brake actuator inactive
01 - Parking brake actuator active
10 - Error
11 - Not available

Data Length: 2 bits
Resolution: 4 states/2 bit, 0 offset
Data Range: 0 to 3 Operational Range: same as data range
Type: Measured
Supporting information:
PGN 65274

SPN 626 Engine Start Enable Device 1

Devices that assist an Engine in starting, e.g. intake heaters and ether. Primary starting aid.
Parameter indicating whether the start enable device 1 is ON or OFF

00 - start enable OFF
01 - start enable ON
10 - reserved
11 - not available

Data Length: 2 bits
Resolution: 4 states/2 bit, 0 offset
Data Range: 0 to 3 Operational Range: same as data range
Type: Status
Supporting information:
PGN 64966

SPN 632 Engine Fuel Shutoff 1 Control

Control setting for fuel shutoff 1. The second instance is SPN 2807. For a single fuel shutoff system, this represents its commanded position. For a dual fuel shutoff system, this SPN is representative of the upstream fuel shutoff commanded position. When fuel (gas) is desired at the engine, the fuel shutoff is opened. Otherwise, it is closed.

00 = Open (fuel supplied to engine)
01 = Closed (no fuel supplied to engine)
10 = Reserved
11 = Don't care / take no action

In addition to communicating desired action of fuel shutoff 1 and its driver status, this new SPN can be used to communicate whether fuel shutoff 1 feedback position (if available) matches the commanded position, through the use of FMIs.

Data Length: 2 bits
Resolution: 4 states/2 bit, 0 offset
Data Range: 0 to 3 Operational Range: same as data range
Type: Status
Supporting information:
PGN 64914

SPN 633 Engine Fuel Actuator 1 Control Command

The control command to fuel actuator 1, normalized to percent, where 0% represents fully closed and 100% represents fully open. Typically, this fuel actuator is used to regulate low pressure natural gas flow rate, mixing into the air flow, which together then come into the engine. Using the standard convention for determining the position. Left/front is #1 and right/rear is #2 (SPN 1244).

Data Length: 2 bytes
Resolution: 0.0025 %/bit, 0 offset
Data Range: 0 to 160.6375 % Operational Range: 0 to 100%
Type: Status
Supporting information:
PGN 61466

SPN 641 Engine Variable Geometry Turbocharger Actuator #1

Actuator that controls the variable geometry turbocharger geometry. The control command to the actuator, normalized to percent, where 0% nominally represents fully closed (smallest turbocharger geometry) and 100% represents fully open (largest geometry turbocharger).

Data Length: 1 byte
Resolution: 0.4 %/bit, 0 offset
Data Range: 0 to 100 % Operational Range: same as data range
Type: Status
Supporting information:
PGN 64931

SPN 681 Transmission Gear Shift Inhibit Request

Command signal to inhibit gear shifts.

00 Gear shifts are allowed (disable function)
01 Gear shifts are inhibited (enable function)
10 Reserved
11 Take no action (leave function as is)

Data Length: 2 bits
Resolution: 4 states/2 bit, 0 offset
Data Range: 0 to 3 Operational Range: same as data range
Type: Status
Supporting information:
PGN 256

SPN 682 Transmission Torque Converter Lockup Disable Request

Command signal to prevent torque converter lockup, which may cause problems in certain circumstances for ASR.

00 Allow torque converter lockup
01 Disable torque converter lockup
10 Reserved
11 Take no action

Data Length: 2 bits
Resolution: 4 states/2 bit, 0 offset
Data Range: 0 to 3 Operational Range: same as data range
Type: Status
Supporting information:
PGN 256

SPN 683 *Disengage Driveline Request*

Command signal used to simply disengage the driveline, e.g., to prevent engine drag torque from causing high wheel slip on slippery surfaces.

00 Allow driveline engagement
01 Disengage driveline
10 Reserved
11 Take no action

Data Length: 2 bits
Resolution: 4 states/2 bit, 0 offset
Data Range: 0 to 3 Operational Range: same as data range
Type: Status
Supporting information:
PGN 256

SPN 684 *Requested Percent Clutch Slip*

Parameter which represents the percent clutch slip requested by a device.

Data Length: 1 byte
Resolution: 0.4 %/bit, 0 offset
Data Range: 0 to 100 % Operational Range: same as data range
Type: Status
Supporting information:
PGN 256

SPN 685 *Disengage Differential Lock Request - Front Axle 1*

Command signal used to disengage the various differential locks, e.g., to allow an undistributed individual wheel control by ABS. The differential locks are located as defined in Figure SPN564_A.

00 Engage differential lock
01 Disengage differential lock
10 Reserved
11 Take no action

Data Length: 2 bits
Resolution: 4 states/2 bit, 0 offset
Data Range: 0 to 3 Operational Range: same as data range
Type: Status
Supporting information:
PGN 256

SPN 686 ***Disengage Differential Lock Request - Front Axle 2***

Command signal used to disengage the various differential locks, e.g., to allow an undistributed individual wheel control by ABS. The differential locks are located as defined in Figure SPN564_A.

00 Engage differential lock
01 Disengage differential lock
10 Reserved
11 Take no action

Data Length: 2 bits
Resolution: 4 states/2 bit, 0 offset
Data Range: 0 to 3 Operational Range: same as data range
Type: Status
Supporting information:
PGN 256

SPN 687 ***Disengage Differential Lock Request - Rear Axle 1***

Command signal used to disengage the various differential locks, e.g., to allow an undistributed individual wheel control by ABS. The differential locks are located as defined in Figure SPN564_A.

00 Engage differential lock
01 Disengage differential lock
10 Reserved
11 Take no action

Data Length: 2 bits
Resolution: 4 states/2 bit, 0 offset
Data Range: 0 to 3 Operational Range: same as data range
Type: Status
Supporting information:
PGN 256

SPN 688 ***Disengage Differential Lock Request - Rear Axle 2***

Command signal used to disengage the various differential locks, e.g., to allow an undistributed individual wheel control by ABS. The differential locks are located as defined in Figure SPN564_A.

00 Engage differential lock
01 Disengage differential lock
10 Reserved
11 Take no action

Data Length: 2 bits
Resolution: 4 states/2 bit, 0 offset
Data Range: 0 to 3 Operational Range: same as data range
Type: Status
Supporting information:
PGN 256

SPN 689 *Disengage Differential Lock Request - Central*

Command signal used to disengage the various differential locks, e.g., to allow an undistributed individual wheel control by ABS. The differential locks are located as defined in Figure SPN564_A.

00 Engage differential lock
 01 Disengage differential lock
 10 Reserved
 11 Take no action

Data Length: 2 bits
 Resolution: 4 states/2 bit, 0 offset
 Data Range: 0 to 3 Operational Range: same as data range
 Type: Status
 Supporting information:
 PGN 256

SPN 690 *Disengage Differential Lock Request - Central Front*

Command signal used to disengage the various differential locks, e.g., to allow an undistributed individual wheel control by ABS. The differential locks are located as defined in Figure SPN564_A.

00 Engage differential lock
 01 Disengage differential lock
 10 Reserved
 11 Take no action

Data Length: 2 bits
 Resolution: 4 states/2 bit, 0 offset
 Data Range: 0 to 3 Operational Range: same as data range
 Type: Status
 Supporting information:
 PGN 256

SPN 691 *Disengage Differential Lock Request - Central Rear*

Command signal used to disengage the various differential locks, e.g., to allow an undistributed individual wheel control by ABS. The differential locks are located as defined in Figure SPN564_A.

00 Engage differential lock
 01 Disengage differential lock
 10 Reserved
 11 Take no action

Data Length: 2 bits
 Resolution: 4 states/2 bit, 0 offset
 Data Range: 0 to 3 Operational Range: same as data range
 Type: Status
 Supporting information:
 PGN 256

SPN 695 Engine Override Control Mode

The override control mode defines which sort of command is used:

- 00 Override disabled - Disable any existing control commanded by the source of this command.
- 01 Speed control - Govern speed to the included "desired speed" value.
- 10 Torque control - Control torque to the included "desired torque" value.
- 11 Speed/torque limit control - Limit speed and/or torque based on the included limit values. The speed limit governor is a droop governor where the speed limit value defines the speed at the maximum torque available during this operation.

If a device wants to know whether it has access to the engine, there are several possibilities:

- a. Comparing its command with the actual engine broadcasts.
- b. Looking at command modes from other devices.
- c. Looking to the engine and retarder torque mode.

Remarks:

- a. The realization of a torque limit (minimum selection) is possible by setting the speed limit to a high value (0xFAFF).
- b. The realization of a speed limit (minimum selection) is possible by setting the torque limit to a high value (0xFA).
- c. Limiting the retarder torque means to limit the magnitude of the torque request. As the brake torque is represented by negative torque values, the limitation must be done by a maximum selection of the requested torque and the retarder internal torque signals.
- d. For torque increasing functions, time limits for the torque or speed value (command) and the direct modes are desirable.
- e. The selection of which device has control of the engine's speed or torque depends on the override mode priority (see SPN 897) with the highest priority device gaining control. In the case of two devices with identical priority, the engine responds to speed/torque control commands over speed/torque limit commands and will act on the speed or torque commands on a first come, first served basis. The torque limit will be a "lowest wins" selection (e.g., if one device commands 60% limit and another 80% limit, then the engine will limit torque to 60%). Figure SPN695_A provides a flowchart of the torque/speed control priority selection logic.

Data Length: 2 bits

Resolution: 4 states/2 bit, 0 offset

Data Range: 0 to 3 Operational Range: same as data range

Type: Status

Supporting information: See Appendix D - SPN 695

PGN 0

SPN 696 Engine Requested Speed Control Conditions

This mode tells the engine control system the governor characteristics that are desired during speed control. The four characteristics defined are:

- 00 Transient Optimized for driveline disengaged and non-lockup conditions
- 01 Stability Optimized for driveline disengaged and non-lockup conditions
- 10 Stability Optimized for driveline engaged and/or in lockup condition 1 (e.g., vehicle driveline)
- 11 Stability Optimized for driveline engaged and/or in lockup condition 2 (e.g., PTO driveline)

00b - This speed governor gain selection is adjusted to provide rapid transition between speed setpoints. RPM overshoot and undershoot may be greater than what is seen when the "speed control characteristic" is set to be stability optimized.

01b - This control condition has been optimized to minimize rpm overshoot and undershoot given an expected plant consisting of the engine and its accessory loads. This gain adjustment is not intended to compensate for driveline characteristics. This characteristic is most appropriate when no driveline is connected.

10b - This control condition has been optimized to minimize rpm overshoot and undershoot given a more complex plant. For instance, the more complex plant would contain the engine, its accessory loads and the driveline characteristics. As an example, the driveline characteristics might include the effective spring mass relationship of pumps, tires, clutches, axles, driveshafts, and multiple gear ratios. This characteristic is most appropriate when a driveline is engaged.

11b - This speed control characteristic is available for applications requiring compensation for more than one driveline characteristic. It has been optimized to minimize rpm overshoot and undershoot given a more complex plant of the second variety. This more complex plant would again contain the engine, its accessory loads and a second driveline characteristic unique from the one described in speed control characteristic 10b.

Data Length: 2 bits
 Resolution: 4 states/2 bit, 0 offset
 Data Range: 0 to 3 Operational Range: same as data range
 Type: Status
 Supporting information:
 PGN 0

SPN 701 Auxiliary I/O #01

Identifies the current status of auxiliary input/output functions that are configured uniquely per application.

- 00 - Auxiliary channel off
- 01 - Auxiliary channel on
- 10 - Error
- 11 - Not available

Data Length: 2 bits
 Resolution: 4 states/2 bit, 0 offset
 Data Range: 0 to 3 Operational Range: same as data range
 Type: Dependent upon Application
 Supporting information:
 PGN 65241

SPN 702 Auxiliary I/O #02

Identifies the current status of auxiliary input/output functions that are configured uniquely per application.

00 - Auxiliary channel off
01 - Auxiliary channel on
10 - Error
11 - Not available

Data Length: 2 bits
Resolution: 4 states/2 bit, 0 offset
Data Range: 0 to 3 Operational Range: same as data range
Type: Dependent upon Application
Supporting information:
PGN 65241

SPN 703 Auxiliary I/O #03

Identifies the current status of auxiliary input/output functions that are configured uniquely per application.

00 - Auxiliary channel off
01 - Auxiliary channel on
10 - Error
11 - Not available

Data Length: 2 bits
Resolution: 4 states/2 bit, 0 offset
Data Range: 0 to 3 Operational Range: same as data range
Type: Dependent upon Application
Supporting information:
PGN 65241

SPN 704 Auxiliary I/O #04

Identifies the current status of auxiliary input/output functions that are configured uniquely per application.

00 - Auxiliary channel off
01 - Auxiliary channel on
10 - Error
11 - Not available

Data Length: 2 bits
Resolution: 4 states/2 bit, 0 offset
Data Range: 0 to 3 Operational Range: same as data range
Type: Dependent upon Application
Supporting information:
PGN 65241

SPN 705 Auxiliary I/O #05

Identifies the current status of auxiliary input/output functions that are configured uniquely per application.

00 - Auxiliary channel off
01 - Auxiliary channel on
10 - Error
11 - Not available

Data Length: 2 bits
Resolution: 4 states/2 bit, 0 offset
Data Range: 0 to 3 Operational Range: same as data range
Type: Dependent upon Application
Supporting information:
PGN 65241

SPN 706 Auxiliary I/O #06

Identifies the current status of auxiliary input/output functions that are configured uniquely per application.

00 - Auxiliary channel off
01 - Auxiliary channel on
10 - Error
11 - Not available

Data Length: 2 bits
Resolution: 4 states/2 bit, 0 offset
Data Range: 0 to 3 Operational Range: same as data range
Type: Dependent upon Application
Supporting information:
PGN 65241

SPN 707 Auxiliary I/O #07

Identifies the current status of auxiliary input/output functions that are configured uniquely per application.

00 - Auxiliary channel off
01 - Auxiliary channel on
10 - Error
11 - Not available

Data Length: 2 bits
Resolution: 4 states/2 bit, 0 offset
Data Range: 0 to 3 Operational Range: same as data range
Type: Dependent upon Application
Supporting information:
PGN 65241

SPN 708 Auxiliary I/O #08

Identifies the current status of auxiliary input/output functions that are configured uniquely per application.

00 - Auxiliary channel off
01 - Auxiliary channel on
10 - Error
11 - Not available

Data Length: 2 bits
Resolution: 4 states/2 bit, 0 offset
Data Range: 0 to 3 Operational Range: same as data range
Type: Dependent upon Application
Supporting information:
PGN 65241

SPN 709 Auxiliary I/O #09

Identifies the current status of auxiliary input/output functions that are configured uniquely per application.

00 - Auxiliary channel off
01 - Auxiliary channel on
10 - Error
11 - Not available

Data Length: 2 bits
Resolution: 4 states/2 bit, 0 offset
Data Range: 0 to 3 Operational Range: same as data range
Type: Dependent upon Application
Supporting information:
PGN 65241

SPN 710 Auxiliary I/O #10

Identifies the current status of auxiliary input/output functions that are configured uniquely per application.

00 - Auxiliary channel off
01 - Auxiliary channel on
10 - Error
11 - Not available

Data Length: 2 bits
Resolution: 4 states/2 bit, 0 offset
Data Range: 0 to 3 Operational Range: same as data range
Type: Dependent upon Application
Supporting information:
PGN 65241

SPN 711 Auxiliary I/O #11

Identifies the current status of auxiliary input/output functions that are configured uniquely per application.

00 - Auxiliary channel off
01 - Auxiliary channel on
10 - Error
11 - Not available

Data Length: 2 bits
Resolution: 4 states/2 bit, 0 offset
Data Range: 0 to 3 Operational Range: same as data range
Type: Dependent upon Application
Supporting information:
PGN 65241

SPN 712 Auxiliary I/O #12

Identifies the current status of auxiliary input/output functions that are configured uniquely per application.

00 - Auxiliary channel off
01 - Auxiliary channel on
10 - Error
11 - Not available

Data Length: 2 bits
Resolution: 4 states/2 bit, 0 offset
Data Range: 0 to 3 Operational Range: same as data range
Type: Dependent upon Application
Supporting information:
PGN 65241

SPN 713 Auxiliary I/O #13

Identifies the current status of auxiliary input/output functions that are configured uniquely per application.

00 - Auxiliary channel off
01 - Auxiliary channel on
10 - Error
11 - Not available

Data Length: 2 bits
Resolution: 4 states/2 bit, 0 offset
Data Range: 0 to 3 Operational Range: same as data range
Type: Dependent upon Application
Supporting information:
PGN 65241

SPN 714 Auxiliary I/O #14

Identifies the current status of auxiliary input/output functions that are configured uniquely per application.

00 - Auxiliary channel off
01 - Auxiliary channel on
10 - Error
11 - Not available

Data Length: 2 bits
Resolution: 4 states/2 bit, 0 offset
Data Range: 0 to 3 Operational Range: same as data range
Type: Dependent upon Application
Supporting information:
PGN 65241

SPN 715 Auxiliary I/O #15

Identifies the current status of auxiliary input/output functions that are configured uniquely per application.

00 - Auxiliary channel off
01 - Auxiliary channel on
10 - Error
11 - Not available

Data Length: 2 bits
Resolution: 4 states/2 bit, 0 offset
Data Range: 0 to 3 Operational Range: same as data range
Type: Dependent upon Application
Supporting information:
PGN 65241

SPN 716 Auxiliary I/O #16

Identifies the current status of auxiliary input/output functions that are configured uniquely per application.

00 - Auxiliary channel off
01 - Auxiliary channel on
10 - Error
11 - Not available

Data Length: 2 bits
Resolution: 4 states/2 bit, 0 offset
Data Range: 0 to 3 Operational Range: same as data range
Type: Dependent upon Application
Supporting information:
PGN 65241

SPN 723 (R) Engine Speed 2

The engine speed as measured by speed sensor 2

Note: This is for the engine speed from the 2nd engine speed sensor. This may be different than SPN 190 when used in multiple engine speed sensor configurations. In an application with multiple engine speed sensors, SPN 190 data can be derived from any of the speed sensors.

Data Length: 2 bytes
Resolution: 0.5 rpm/bit, 0 offset
Data Range: 0 to 32,127.5 rpm Operational Range: same as data range
Type: Measured
Supporting information:
PGN 61473

SPN 740 Transmission Lockup Clutch Actuator

Identifies the status of the actuator that controls the lockup clutch.

00 - Off
01 - On
10 - Error
11 - Not available

Data Length: 2 bits
Resolution: 4 states/2 bit, 0 offset
Data Range: 0 to 3 Operational Range: same as data range
Type: Status
Supporting information:
PGN 65223

SPN 748 Transmission Output Retarder

Identifies the status of the transmission output retarder.

00 - Off
01 - On
10 - Error
11 - Not available

Data Length: 2 bits
Resolution: 4 states/2 bit, 0 offset
Data Range: 0 to 3 Operational Range: same as data range
Type: Status
Supporting information:
PGN 65218

SPN 767 **Transmission Reverse Direction Switch**

Identifies the status of the switch that indicates reverse direction.

00 - Off
01 - On
10 - Error
11 - Not available

Data Length: 2 bits
Resolution: 4 states/2 bit, 0 offset
Data Range: 0 to 3 Operational Range: same as data range
Type: Status
Supporting information:
PGN 65219

SPN 768 **Transmission Range High Actuator**

Identifies the status of the range high actuator in the auxiliary unit.

00 -Off
01 -On
10 - Error
11 - Not available

Data Length: 2 bits
Resolution: 4 states/2 bit, 0 offset
Data Range: 0 to 3 Operational Range: same as data range
Type: Status
Supporting information:
PGN 65223

SPN 769 **Transmission Range Low Actuator**

Identifies the status of the range low actuator in the auxiliary unit.

00 - Off
01 - On
10 - Error
11 - Not available

Data Length: 2 bits
Resolution: 4 states/2 bit, 0 offset
Data Range: 0 to 3 Operational Range: same as data range
Type: Status
Supporting information:
PGN 65223

SPN 770 ***Transmission Splitter Direct Actuator***

Identifies the status of the splitter direct actuator in the auxiliary unit.

00 - Off
01 - On
10 - Error
11 - Not available

Data Length: 2 bits
Resolution: 4 states/2 bit, 0 offset
Data Range: 0 to 3 Operational Range: same as data range
Type: Status
Supporting information:
PGN 65223

SPN 771 ***Transmission Splitter Indirect Actuator***

Identifies the status of the splitter indirect actuator in the auxiliary unit.

00 - Off
01 - On
10 - Error
11 - Not available

Data Length: 2 bits
Resolution: 4 states/2 bit, 0 offset
Data Range: 0 to 3 Operational Range: same as data range
Type: Status
Supporting information:
PGN 65223

SPN 772 ***Transmission Shift Finger Rail Actuator 1***

Identifies the status of the actuator that moves the shift finger identified as rail actuator #1.

00 - Off
01 - On
10 - Error
11 - Not available

Data Length: 2 bits
Resolution: 4 states/2 bit, 0 offset
Data Range: 0 to 3 Operational Range: same as data range
Type: Status
Supporting information:
PGN 65223

SPN 773 **Transmission Shift Finger Gear Actuator 1**

Identifies the status of the actuator that moves the shift finger identified as gear actuator #1.

00 - Off
01 - On
10 - Error
11 - Not available

Data Length: 2 bits
Resolution: 4 states/2 bit, 0 offset
Data Range: 0 to 3 Operational Range: same as data range
Type: Status
Supporting information:
PGN 65223

SPN 778 **Transmission High Range Sense Switch**

Identifies the status of the switch that represents high range.

00 - Off
01 - On
10 - Error
11 - Not available

Data Length: 2 bits
Resolution: 4 states/2 bit, 0 offset
Data Range: 0 to 3 Operational Range: same as data range
Type: Status
Supporting information:
PGN 65219

SPN 779 **Transmission Low Range Sense Switch**

Identifies the status of the switch that represents low range.

00 - Off
01 - On
10 - Error
11 - Not available

Data Length: 2 bits
Resolution: 4 states/2 bit, 0 offset
Data Range: 0 to 3 Operational Range: same as data range
Type: Status
Supporting information:
PGN 65219

SPN 780 *Transmission Shift Finger Neutral Indicator*

Indicates the status of the shift finger in the neutral position.

00 - Off
01 - On
10 - Error
11 - Not available

Data Length: 2 bits
Resolution: 4 states/2 bit, 0 offset
Data Range: 0 to 3 Operational Range: same as data range
Type: Status
Supporting information:
PGN 65223

SPN 781 *Transmission Shift Finger Engagement Indicator*

Identifies the status of the shift finger in the engagement position.

00 - Off
01 - On
10 - Error
11 - Not available

Data Length: 2 bits
Resolution: 4 states/2 bit, 0 offset
Data Range: 0 to 3 Operational Range: same as data range
Type: Status
Supporting information:
PGN 65223

SPN 782 *Transmission Shift Finger Center Rail Indicator*

Identifies the status of the shift finger in the center rail position.

00 - Off
01 - On
10 - Error
11 - Not available

Data Length: 2 bits
Resolution: 4 states/2 bit, 0 offset
Data Range: 0 to 3 Operational Range: same as data range
Type: Status
Supporting information:
PGN 65223

SPN 783 **Transmission Shift Finger Rail Actuator 2**

Identifies the status of the actuator that moves the shift finger identified as rail actuator #2.

00 - Off
01 - On
10 - Error
11 - Not available

Data Length: 2 bits
Resolution: 4 states/2 bit, 0 offset
Data Range: 0 to 3 Operational Range: same as data range
Type: Status
Supporting information:
PGN 65223

SPN 784 **Transmission Shift Finger Gear Actuator 2**

Identifies the status of the actuator that moves the shift finger identified as gear actuator #2.

00 - Off
01 - On
10 - Error
11 - Not available

Data Length: 2 bits
Resolution: 4 states/2 bit, 0 offset
Data Range: 0 to 3 Operational Range: same as data range
Type: Status
Supporting information:
PGN 65223

SPN 786 **Transmission Defuel Actuator**

Identifies the status of the actuator that controls the engine defuel mechanism.

00 - Off
01 - On
10 - Error
11 - Not available

Data Length: 2 bits
Resolution: 4 states/2 bit, 0 offset
Data Range: 0 to 3 Operational Range: same as data range
Type: Status
Supporting information:
PGN 65223

SPN 787 *Transmission Inertia Brake Actuator*

Identifies the status of the actuator that controls the inertia brake.

00 - Off
01 - On
10 - Error
11 - Not available

Data Length: 2 bits
Resolution: 4 states/2 bit, 0 offset
Data Range: 0 to 3 Operational Range: same as data range
Type: Status
Supporting information:
PGN 65223

SPN 788 *Transmission Clutch Actuator*

Identifies the status of the actuator that controls the clutch.

00 - Off
01 - On
10 - Error
11 - Not available

Data Length: 2 bits
Resolution: 4 states/2 bit, 0 offset
Data Range: 0 to 3 Operational Range: same as data range
Type: Status
Supporting information:
PGN 65223

SPN 875 *Refrigerant Low Pressure Switch*

Switch signal which indicates the position of the low pressure switch in the coolant circuit of an air conditioning system. When the switch is enabled, the pressure inside the circuit is too low and the compressor clutch may be disengaged.

00 - Pressure normal
01 - Pressure too low, compressor clutch may be disengaged
10 - Error
11 - Not available

Data Length: 2 bits
Resolution: 4 states/2 bit, 0 offset
Data Range: 0 to 3 Operational Range: same as data range
Type: Measured
Supporting information:
PGN 65252

SPN 897 ***Override Control Mode Priority***

This field is used as an input to the engine or retarder to determine the priority of the Override Control Mode received in the Torque/Speed Control message (see PGN 0). The default is 11 (Low priority). It is not required to use the same priority during the entire override function. For example, the transmission can use priority 01 (High priority) during a shift, but can set the priority to 11 (Low priority) at the end of the shift to allow traction control to also interact with the torque limit of the engine.

The four priority levels defined are:

00 Highest priority
 01 High priority
 10 Medium priority
 11 Low priority

00b - Highest Priority = Used for situations that require immediate action by the receiving device in order to provide safe vehicle operation (i.e., braking systems). This level of priority should only be used in safety critical conditions.

01b - High Priority = Used for control situations that require prompt action in order to provide safe vehicle operation. An example is when the transmission is performing a shift and requires control of the engine in order to control driveline reengagement.

10b - Medium Priority = Used for powertrain control operations which are related to assuring that the vehicle is in a stable operating condition. An example is when the traction control system is commanding the engine in order to achieve traction stability.

11b - Low Priority = Used to indicate that the associated command desires powertrain control but is needed for function which improves the driver comfort which may be overridden by other devices. An example is cruise control or the non-critical part of a transmission shift to a new gear.

Data Length: 2 bits

Resolution: 4 states/2 bit, 0 offset

Data Range: 0 to 3 Operational Range: same as data range

Type: Status

Supporting information:

PGN 0

SPN 898 ***Engine Requested Speed/Speed Limit***

Parameter provided to the engine from external sources in the torque/speed control message. This is the engine speed which the engine is expected to operate at if the speed control mode is active or the engine speed which the engine is not expected to exceed if the speed limit mode is active.

Data Length: 2 bytes

Resolution: 0.125 rpm/bit, 0 offset

Data Range: 0 to 8,031.875 rpm Operational Range: same as data range

Type: Status

Supporting information:

PGN 0

SPN 899 Engine Torque Mode

State signal which indicates which engine torque mode is currently generating, limiting, or controlling the torque. Note that the modes are not in prioritized order. Not all modes may be relevant for a given device. Some devices may not implement all functions. For typical priorities refer to Figures SPN512_A and SPN512_B for engine control. The data type of this parameter is measured.

Mode 0000b means "No request": engine torque may range from 0 to full load only due to low idle governor output.

Modes 0001b to 1110b indicate that there is either a torque request or the identified function is currently controlling the engine: engine torque may range from 0 (no fueling) to the upper limit.

Data Length: 4 bits
Resolution: 16 states/4 bit, 0 offset
Data Range: 0 to 15 Operational Range: same as data range
Type: Measured
Supporting information: See Appendix D - SPN 899
PGN 61444

SPN 900 Retarder Torque Mode

State signal which indicates which retarder torque mode is currently generating, limiting, or controlling the torque. Note that the modes are not in prioritized order. Not all modes may be relevant for a given device. Some devices may not implement all functions. For typical priorities refer to Tables SPN518_A to SPN518_B for retarder control. The data type of this parameter is measured.

Mode 0000b means "No request": retarder torque = 0 (no braking).

Modes 0001b to 1110b indicate that there is either a torque request or the identified function is currently controlling the retarder: retarder torque may range from 0 (no braking) to the upper limit.

Data Length: 4 bits
Resolution: 16 states/4 bit, 0 offset
Data Range: 0 to 15 Operational Range: same as data range
Type: Measured
Supporting information: See Appendix D - SPN 899
PGN 61440

SPN 901 Retarder Type

A vehicle retarder is a supplementary device to the wheel brakes for the driver to better control the vehicle. The wheel brakes used in the vehicle are not designed for continuous retarding operation. In a prolonged period of braking, the brakes can be thermally over-stressed, causing the braking effect to be reduced or even lead to complete braking system failure. The vehicle retarder is designed for continuous operation for braking during downhill operation and is also used for braking the vehicle to comply with speed limits and traffic conditions.

This parameter provides some indication of the retarder dynamics. It is used in the retarder configuration message. The data type of this parameter is measured.

0000 Electric/Magnetic
0001 Hydraulic
0010 Cooled Friction
0011 Compression Release (Engine retarder)
0100 Exhaust
0101-1101 Not defined
1110 Other
1111 Not available

Data Length: 4 bits
Resolution: 16 states/4 bit, 0 offset
Data Range: 0 to 15 Operational Range: same as data range
Type: Measured
Supporting information: See Appendix D - SPN 901
PGN 65249

SPN 902 Retarder Location

This parameter defines whether the "torque/speed curve" defined by the retarder configuration message (PGN 65249) is dependent on engine rpm, output shaft rpm, or other parameter. The data type of this parameter is measured.

0000 (Primary) Engine Compression Release Brake (Engine rpm)
0001 (Primary) Engine Exhaust Brake (Exhaust pressure)
0010 (Primary) Transmission Input (Engine rpm)
0011 (Secondary) Transmission Output (Output Shaft rpm)
0100 (Secondary) Driveline (Output Shaft rpm)
0101 Trailer (Vehicle speed)
0110-1101 Not defined
1110 Other
1111 Not available

Data Length: 4 bits
Resolution: 16 states/4 bit, 0 offset
Data Range: 0 to 15 Operational Range: same as data range
Type: Measured
Supporting information:
PGN 65249

SPN 903 **Transmission Forward Direction Switch**

Identifies the status of the switch that indicates forward direction.

00 - Off
 01 - On
 10 - Error
 11 - Not available

Data Length: 2 bits
 Resolution: 4 states/2 bit, 0 offset
 Data Range: 0 to 3 Operational Range: same as data range
 Type: Status
 Supporting information:
 PGN 65219

SPN 904 **Front Axle Speed**

The average speed of the two front wheels.

Data Length: 2 bytes
 Resolution: 1/256 km/h per bit, 0 offset
 Data Range: 0 to 250.996 km/h Operational Range: same as data range
 Type: Measured
 Supporting information:
 PGN 65215

SPN 905 **Relative Speed; Front Axle, Left Wheel**

The speed of the front axle, left wheel relative to the front axle speed, SPN 904.

Data Length: 1 byte
 Resolution: 1/16 km/h per bit, -7.8125 km/h offset
 Data Range: -7.8125 to 7.8125 km/h Operational Range: same as data range
 Type: Measured
 Supporting information:
 PGN 65215

SPN 906 **Relative Speed; Front Axle, Right Wheel**

The speed of the front axle, right wheel relative to the front axle speed, SPN 904.

Data Length: 1 byte
 Resolution: 1/16 km/h per bit, -7.8125 km/h offset
 Data Range: -7.8125 to 7.8125 km/h Operational Range: same as data range
 Type: Measured
 Supporting information:
 PGN 65215

SPN 907 **Relative Speed; Rear Axle #1, Left Wheel**

The speed of the rear axle #1, left wheel relative to the front axle speed, SPN 904.

Data Length: 1 byte

Resolution: 1/16 km/h per bit, -7.8125 km/h offset

Data Range: -7.8125 to 7.8125 km/h Operational Range: same as data range

Type: Measured

Supporting information:

PGN 65215

SPN 908 **Relative Speed; Rear Axle #1, Right Wheel**

The speed of the rear axle #1, right wheel relative to the front axle speed, SPN 904.

Data Length: 1 byte

Resolution: 1/16 km/h per bit, -7.8125 km/h offset

Data Range: -7.8125 to 7.8125 km/h Operational Range: same as data range

Type: Measured

Supporting information:

PGN 65215

SPN 909 **Relative Speed; Rear Axle #2, Left Wheel**

The speed of the rear axle #2, left wheel relative to the front axle speed, SPN 904.

Data Length: 1 byte

Resolution: 1/16 km/h per bit, -7.8125 km/h offset

Data Range: -7.8125 to 7.8125 km/h Operational Range: same as data range

Type: Measured

Supporting information:

PGN 65215

SPN 910 **Relative Speed; Rear Axle #2, Right Wheel**

The speed of the rear axle #2, right wheel relative to the front axle speed, SPN 904.

Data Length: 1 byte

Resolution: 1/16 km/h per bit, -7.8125 km/h offset

Data Range: -7.8125 to 7.8125 km/h Operational Range: same as data range

Type: Measured

Supporting information:

PGN 65215

SPN 911 Service Component Identification

Identification of component needing service. See Table SPN911_A.

Data Length: 1 byte

Resolution: 1 ID/bit, 0 offset

Data Range: 0 to 250 ID Operational Range: same as data range

Type: Measured

Supporting information: See Appendix D - SPN 911

PGN 65216

SPN 912 Service Component Identification

Identification of component needing service. See Table SPN911_A.

Data Length: 1 byte

Resolution: 1 ID/bit, 0 offset

Data Range: 0 to 250 ID Operational Range: same as data range

Type: Measured

Supporting information:

PGN 65216

SPN 913 Service Component Identification

Identification of component needing service. See Table SPN911_A.

Data Length: 1 byte

Resolution: 1 ID/bit, 0 offset

Data Range: 0 to 250 ID Operational Range: same as data range

Type: Measured

Supporting information:

PGN 65216

SPN 914 Service Distance

The distance which can be traveled by the vehicle before the next service inspection is required. A negative distance is transmitted if the service inspection has been passed. The component that requires service is identified by the service component identification (see SPN 911-913, 1379, and 1584).

Data Length: 2 bytes

Resolution: 5 km/bit, -160,635 km offset

Data Range: -160,635 to 160,640 km Operational Range: same as data range

Type: Measured

Supporting information:

PGN 65216

SPN 915 Service Delay/Calendar Time Based

The time in weeks until the next vehicle service inspection is required. A negative value is transmitted if the service inspection has been passed. The component that requires service is identified by the service component identification (see SPN 911-913, 1379, and 1584).

Data Length: 1 byte
Resolution: 1 week/bit, -125 weeks offset
Data Range: -125 to 125 weeks Operational Range: same as data range
Type: Measured
Supporting information:
PGN 65216

SPN 916 Service Delay/Operational Time Based

The time in vehicle operational time until the next vehicle service inspection is required. A negative value is transmitted if the service inspection has been passed. The component that requires service is identified by the service component identification (see SPN 911-913, 1379, and 1584).

Data Length: 2 bytes
Resolution: 1 hr/bit, -32,127 hr offset
Data Range: -32,127 to 32,128 hr Operational Range: same as data range
Type: Measured
Supporting information:
PGN 65216

SPN 917 High Resolution Total Vehicle Distance

Accumulated distance traveled by the vehicle during its operation.

NOTE - See SPN 245 for alternate resolution.

Data Length: 4 bytes
Resolution: 5 m/bit, 0 offset
Data Range: 0 to 21,055,406 km Operational Range: same as data range
Type: Measured
Supporting information:
PGN 65217

SPN 918 High Resolution Trip Distance

Distance traveled during all or part of a journey.

NOTE - See SPN 244 for alternate resolution.

Data Length: 4 bytes
Resolution: 5 m/bit, 0 offset
Data Range: 0 to 21,055,406 km Operational Range: same as data range
Type: Measured
Supporting information:
PGN 65217

SPN 927 Location

To identify to which of several similar devices (such as tires or fuel tanks) the information applies.

The low order 4 bits represent a position number, counting left to right when facing in the direction of normal vehicle travel (forward).

The high order 4 bits represent a position number, counting front to back on the vehicle.

The value 0xFF indicates not available.

It is recommended that output devices add 1 to the position number (range 1 to 15, not 0 to 14) for use by drivers and service technicians.

Examples: Tire pressure for location 0x00 would be left front tire.

Tire pressure for location 0x23 would be right outside rear rear on a 3-axle tractor with dual axle per side (3rd axle, 4th tire).

Data Length: 8 bits
Resolution: 256 states/8 bit, 0 offset
Data Range: 0 to 255 Operational Range: same as data range
Type: Measured
Supporting information:
PGN 61446

SPN 928 Axle Location

To identify to which of several similar devices (such as tires or fuel tanks) the information applies.

The low order 4 bits represent a position number, counting left to right when facing in the direction of normal vehicle travel (forward).

The high order 4 bits represent a position number, counting front to back on the vehicle.

The value 0xFF indicates not available.

It is recommended that output devices add 1 to the position number (range 1 to 15, not 0 to 14) for use by drivers and service technicians.

Examples: Tire pressure for location 0x00 would be left front tire.

Tire pressure for location 0x23 would be right outside rear rear on a 3-axle tractor with dual axle per side (3rd axle, 4th tire).

Data Length: 8 bits
Resolution: 256 states/8 bit, 0 offset
Data Range: 0 to 255 Operational Range: same as data range
Type: Measured
Supporting information:
PGN 65258

SPN 929 **Tire Location**

Identifies which tire is associated with the parametric data in this PGN.

The low order 4 bits represent a position number, counting left to right when facing in the direction of normal vehicle travel (forward).

The high order 4 bits represent a position number, counting front to back on the vehicle.

The value 0xFF indicates not available.

It is recommended that output devices add 1 to the position number (range 1 to 15, not 0 to 14) for use by drivers and service technicians.

Examples: Tire pressure for location 0x00 would be left front tire.

Tire pressure for location 0x23 would be right outside rear rear on a 3-axle tractor with dual axle per side (3rd axle, 4th tire).

Data Length: 8 bits
Resolution: 256 states/8 bit, 0 offset
Data Range: 0 to 255 Operational Range: same as data range
Type: Measured
Supporting information:
PGN 65268

SPN 930 **Drive Axle Location**

To identify to which of several similar devices (such as tires or fuel tanks) the information applies.

The low order 4 bits represent a position number, counting left to right when facing in the direction of normal vehicle travel (forward).

The high order 4 bits represent a position number, counting front to back on the vehicle.

The value 0xFF indicates not available.

It is recommended that output devices add 1 to the position number (range 1 to 15, not 0 to 14) for use by drivers and service technicians.

Examples: Tire pressure for location 0x00 would be left front tire.

Tire pressure for location 0x23 would be right outside rear rear on a 3-axle tractor with dual axle per side (3rd axle, 4th tire).

Data Length: 8 bits
Resolution: 256 states/8 bit, 0 offset
Data Range: 0 to 255 Operational Range: same as data range
Type: Measured
Supporting information:
PGN 65273

SPN 957 **Number of Forward Gear Ratios**

Number of forward gear ratios in the transmission, provided as part of the configuration.

Data Length: 1 byte
Resolution: 1 gear value/bit, 0 offset
Data Range: 0 to 250 Operational Range: 0 to 125 gear ratios
Type: Measured
Supporting information:
PGN 65250

SPN 958 **Number of Reverse Gear Ratios**

Number of reverse gear ratios in the transmission, provided as part of the transmission configuration.

Data Length: 1 byte

Resolution: 1 gear value/bit, 0 offset

Data Range: 0 to 250

Operational Range: 0 to 125 gear ratios

Type: Measured

Supporting information:

PGN 65250

SPN 959 **Seconds**

Part of a parameter used to represent time.

Data Length: 1 byte

Resolution: 0.25 s/bit, 0 offset

Data Range: 0 to 62.5 s

Operational Range: 0 to 59.75 sec

Type: Measured

Supporting information:

PGN 65254

SPN 960 **Minutes**

Part of a parameter used to represent time.

Data Length: 1 byte

Resolution: 1 min/bit, 0 offset

Data Range: 0 to 250 mins

Operational Range: 0 to 59 min

Type: Measured

Supporting information:

PGN 65254

SPN 961 **Hours**

Part of a parameter used to represent time.

Data Length: 1 byte

Resolution: 1 hr/bit, 0 offset

Data Range: 0 to 250 hr

Operational Range: 0 to 23 hr

Type: Measured

Supporting information:

PGN 65254

SPN 962 Day

Part of a parameter used to represent a calendar date.

NOTE - A value of 0 for the date is null. The values 1, 2, 3, and 4 are used to identify the first day of the month; 5, 6, 7, and 8 identify the second day of the month; etc.

Data Length: 1 byte
Resolution: 0.25 days/bit, 0 offset
Data Range: 0 to 62.5 days Operational Range: 0.25 to 31.75 day
Type: Measured
Supporting information:
PGN 65254

SPN 963 Month

Part of a parameter used to represent a calendar date.

NOTE - A value of 0 for the month is null. The value 1 identifies January; 2 identifies February; etc.

Data Length: 1 byte
Resolution: 1 month/bit, 0 offset
Data Range: 0 to 250 months Operational Range: 1 to 12 month
Type: Measured
Supporting information:
PGN 65254

SPN 964 Year

Part of a parameter used to represent a calendar date.

NOTE - A value of 0 for the year identifies the year 1985; a value of 1 identifies 1986; etc.

Data Length: 1 byte
Resolution: 1 year/bit, 1985 years offset
Data Range: 1985 to 2235 years Operational Range: same as data range
Type: Measured
Supporting information:
PGN 65254

SPN 965 Number of Software Identification Fields

Number of software identification designators represented in the software identification parameter group.

Data Length: 1 byte
Resolution: 1 step/bit, 0 offset
Data Range: 0 to 250 steps Operational Range: 0 to 125
Type: Measured
Supporting information:
PGN 65242

SPN 966 Engine Test Mode Switch

Switch signal which indicates the position of the engine test mode switch.

00 - Off
01 - On
10 - Error
11 - Not available

Data Length: 2 bits
Resolution: 4 states/2 bit, 0 offset
Data Range: 0 to 3 Operational Range: same as data range
Type: Measured
Supporting information:
PGN 65265

SPN 967 Engine Idle Decrement Switch

Switch signal which indicates the position of the idle decrement switch.

00 - Off
01 - On
10 - Error
11 - Not available

Data Length: 2 bits
Resolution: 4 states/2 bit, 0 offset
Data Range: 0 to 3 Operational Range: same as data range
Type: Measured
Supporting information:
PGN 65265

SPN 968 Engine Idle Increment Switch

Switch signal which indicates the position of the idle increment switch.

00 - Off
01 - On
10 - Error
11 - Not available

Data Length: 2 bits
Resolution: 4 states/2 bit, 0 offset
Data Range: 0 to 3 Operational Range: same as data range
Type: Measured
Supporting information:
PGN 65265

SPN 969 Remote Accelerator Enable Switch

Switch signal which indicates that the remote accelerator has been enabled and controls the engine.

00 - Off
01 - On
10 - Error
11 - Not available

NOTE—The accelerator interlock switch (see SPN 972) must be disabled in order for the remote accelerator to perform engine control.

Data Length: 2 bits
Resolution: 4 states/2 bit, 0 offset
Data Range: 0 to 3 Operational Range: same as data range
Type: Measured
Supporting information:
PGN 61441

SPN 970 Engine Auxiliary Shutdown Switch

Switch signal which requests that all engine fueling stop.

00 - Off
01 - On
10 - Error
11 - Not available

Data Length: 2 bits
Resolution: 4 states/2 bit, 0 offset
Data Range: 0 to 3 Operational Range: same as data range
Type: Measured
Supporting information:
PGN 61441

SPN 971 Engine Derate Switch

Switch signal used to activate the torque limiting feature of the engine. The specific nature of torque limiting should be verified with the manufacturer.

00 - Off
01 - On
10 - Error
11 - Not available

Data Length: 2 bits
Resolution: 4 states/2 bit, 0 offset
Data Range: 0 to 3 Operational Range: same as data range
Type: Measured
Supporting information:
PGN 61441

SPN 972 Accelerator Interlock Switch

Switch signal used to disable the accelerator and remote accelerator inputs, causing the engine to return to idle.

00 - Off
 01 - On
 10 - Error
 11 - Not available

Data Length: 2 bits
 Resolution: 4 states/2 bit, 0 offset
 Data Range: 0 to 3 Operational Range: same as data range
 Type: Measured
 Supporting information:
 PGN 61441

SPN 973 Engine Retarder Selection

The position of the operator controlled selector, expressed as a percentage and determined by the ratio of the current position of the selector to its maximum possible position. Zero percent means no braking torque is requested by the operator from the engine while 100% means maximum braking.

Data Length: 1 byte
 Resolution: 0.4 %/bit, 0 offset
 Data Range: 0 to 100 % Operational Range: same as data range
 Type: Measured
 Supporting information:
 PGN 61441

SPN 974 Remote Accelerator Pedal Position

The ratio of actual position of the remote analog engine speed/torque request input device (such as an accelerator pedal or throttle lever) to the maximum position of the input device.

For example, in on-highway vehicles this could be an accelerator control device that is external to the drivers cab or an accelerator that is controlled by a hand lever from the operators seat.

The Remote Accelerator Enable Switch is SPN 969. This parameter enables the remote accelerator operation.

NOTE—See SPNs 28, 29, and 91 for additional accelerator position parameters. If only one accelerator position exists on a vehicle, SPN 91 shall be used

Data Length: 1 byte
 Resolution: 0.4 %/bit, 0 offset
 Data Range: 0 to 100 % Operational Range: same as data range
 Type: Measured
 Supporting information:
 PGN 61443

SPN 975 ***Estimated Percent Fan Speed***

Estimated fan speed as a ratio of the fan drive (current speed) to the fully engaged fan drive (maximum fan speed). A two state fan (off/on) will use 0% and 100% respectively. A three state fan (off/intermediate/on) will use 0%, 50% and 100% respectively. A variable speed fan will use 0% to 100%. Multiple fan systems will use 0 to 100% to indicate the percent cooling capacity being provided.

Note that the intermediate fan speed of a three state fan will vary with different fan drives, therefore 50% is being used to indicate that the intermediate speed is required from the fan drive.

Data Length: 1 byte

Resolution: 0.4 %/bit, 0 offset

Data Range: 0 to 100 %

Operational Range: same as data range

Type: Status

Supporting information:

PGN 65213

SPN 976 (R) PTO Governor State

This parameter is used to indicate the current state or mode of operation by the power takeoff (PTO) governor. In lieu of support for PTO Drive Engagement parameters, this parameter may represent the status of a PTO drive. The broadcasting device must ensure that each achieved state is conveyed in at least one message broadcast before a transition to another state is allowed.

00000 Off/Disabled
 00001 Hold
 00010 Remote Hold
 00011 Standby
 00100 Remote Standby
 00101 Set
 00110 Decelerate/Coast
 00111 Resume
 01000 Accelerate
 01001 Accelerator Override
 01010 Preprogrammed set speed 1
 01011 Preprogrammed set speed 2
 01100 Preprogrammed set speed 3
 01101 Preprogrammed set speed 4
 01110 Preprogrammed set speed 5
 01111 Preprogrammed set speed 6
 10000 Preprogrammed set speed 7
 10001 Preprogrammed set speed 8
 10010 PTO set speed memory 1
 10011 PTO set speed memory 2
 10100-11110 Not defined
 11111 Not available

Off/Disabled 00000b — Used to indicate that the PTO governor enable switch is in the off position.

Hold 00001b — Used to indicate that the PTO governor is active and currently maintaining a captured operating speed.

Remote Hold 00010b — Used to indicate that the remote PTO governor is active and the PTO governor is currently maintaining a captured operating speed.

Standby 00011b — Used to indicate that the PTO governor device enable switch is in the ON position and it is possible to manage the PTO governor.

Remote Standby 00100b — Used to indicate that the remote PTO governor device enable switch is in the ON position and it is possible to manage the PTO governor.

Set 00101b — Used to indicate that the PTO governor is establishing current speed as the operating speed (captured value).

Decelerate/Coast 00110b — Used to indicate that the PTO governor is in the process of ramping down, or coasting, from the current operating speed.

Resume 00111b — Used to indicate that the PTO governor is in the process of resuming the operating speed to a previously captured value.

Accelerate 01000b — Used to indicate that the PTO governor is in the process of ramping up the operating speed.

Accelerator Override 01001b—Used to indicate that the PTO governor is active but for the present time the engine is controlled by a large driver's demand.

Preprogrammed PTO Governor Set Speed 1 01010b—Used to indicate that the PTO device is establishing a first preprogrammed PTO governor set speed (user programmable) as the current operating speed.

Preprogrammed PTO Governor Set Speed 2 01011b—Used to indicate that the PTO device is establishing a second preprogrammed PTO governor set speed (user programmable) as the current operating speed.

Preprogrammed PTO Governor Set Speed 3 01100b —Used to indicate that the remote PTO device is establishing a third preprogrammed PTO governor set speed (user programmable) as the current operating speed.

Preprogrammed PTO Governor Set Speed 4 01101b —Used to indicate that the remote PTO device is establishing a fourth preprogrammed PTO governor set speed (user programmable) as the current operating speed.

Preprogrammed PTO Governor Set Speed 5 01110b —Used to indicate that the remote PTO device is establishing a fifth preprogrammed PTO governor set speed (user programmable) as the current operating speed.

Preprogrammed PTO Governor Set Speed 6 01111b—Used to indicate that the remote PTO device is establishing a sixth preprogrammed PTO governor set speed (user programmable) as the current operating speed.

Preprogrammed PTO Governor Set Speed 7 10000b —Used to indicate that the remote PTO device is establishing a seventh preprogrammed PTO governor set speed (user programmable) as the current operating speed.

Preprogrammed PTO Governor Set Speed 8 10001b —Used to indicate that the remote PTO device is establishing a eighth preprogrammed PTO governor set speed (user programmable) as the current operating speed.

PTO set speed memory 1 10010b —Used to indicate that PTO set speed memory one set state is active.

PTO set speed memory 2 10011b — Used to indicate that PTO set speed memory two set state is active.

Data Length: 5 bits

Resolution: 32 states/5 bit, 0 offset

Data Range: 0 to 31

Operational Range: same as data range

Type: Status

Supporting information:

PGN 65265

SPN 977 Fan Drive State

This parameter is used to indicate the current state or mode of operation by the fan drive.

0000 Fan off
 0001 Engine system—General
 0010 Excessive engine air temperature
 0011 Excessive engine oil temperature
 0100 Excessive engine coolant temperature
 0101 Excessive transmission oil temperature
 0110 Excessive hydraulic oil temperature
 0111 Default Operation
 1000 Not defined
 1001 Manual control
 1010 Transmission retarder
 1011 A/C system
 1100 Timer
 1101 Engine brake
 1110 Other
 1111 Not available

Fan off 0000b —Used to indicate that the fan clutch is disengaged and the fan is inactive

Engine system—General 0001b —Used to indicate that the fan is active due to an engine system not otherwise defined.

Excessive engine air temperature 0010b —Used to indicate that the fan is active due to high air temperature.

Excessive engine oil temperature 0011b —Used to indicate that the fan is active due to high oil temperature.

Excessive engine coolant temperature 0100b —Used to indicate that the fan is active due to high coolant temperature.

Manual control 1001b —Used to indicate that the fan is active as requested by the operator.

Transmission retarder 1010b —Used to indicate that the fan is active as required by the transmission retarder.

A/C system 1011b —Used to indicate that the fan is active as required by the air conditioning system.

Timer 1100b —Used to indicate that the fan is active as required by a timing function.

Engine brake 1101b —Used to indicate that the fan is active as required to assist engine braking.

Excessive transmission oil temperature - 0101b - Used to indicate fan is active due to excessive transmission oil temperature.

Excessive hydraulic oil temperature - 0110b - Used to indicate fan is active due to excessive hydraulic oil temperature.

Default Operation - 0111b - Used to indicate fan is active due to a error condition resulting in default operation

Data Length: 4 bits

Resolution: 16 states/4 bit, 0 offset

Data Range: 0 to 15

Operational Range: same as data range

Type: Status

Supporting information:

PGN 65213

SPN 978 Engine Remote PTO Governor Variable Speed Control Switch

Switch signal which indicates that the remote PTO governor toggle switch is in the enabled (ON) position. If the toggle switch is enabled and other conditions are satisfied then the remote PTO governor feature is activated and the PTO governor will control at a variable speed.

00 - Off
01 - On
10 - Error
11 - Not available

Data Length: 2 bits
Resolution: 4 states/2 bit, 0 offset
Data Range: 0 to 3 Operational Range: same as data range
Type: Measured
Supporting information:
PGN 65264

SPN 979 Engine Remote PTO Governor Preprogrammed Speed Control Switch

Switch signal which indicates that the remote PTO governor toggle switch is in the enabled (ON) position. If the toggle switch is enabled and other conditions are satisfied then the remote PTO governor feature is activated and the PTO governor will control at the preprogrammed speed.

00 - Off
01 - On
10 - Error
11 - Not available

Data Length: 2 bits
Resolution: 4 states/2 bit, 0 offset
Data Range: 0 to 3 Operational Range: same as data range
Type: Measured
Supporting information:
PGN 65264

SPN 980 Engine PTO Governor Enable Switch

Switch signal which indicates that the PTO governor toggle switch is in the enabled (ON) position and therefore it is possible to manage the PTO control function.

00 - Off
01 - On
10 - Error
11 - Not available

Data Length: 2 bits
Resolution: 4 states/2 bit, 0 offset
Data Range: 0 to 3 Operational Range: same as data range
Type: Measured
Supporting information:
PGN 65264

SPN 981 Engine PTO Governor Accelerate Switch

Switch signal of the PTO control activator which indicates that the activator is in the position to "accelerate" the PTO governor set speed.

00 - Off
01 - On
10 - Error
11 - Not available

Data Length: 2 bits
Resolution: 4 states/2 bit, 0 offset
Data Range: 0 to 3 Operational Range: same as data range
Type: Measured
Supporting information:
PGN 65264

SPN 982 Engine PTO Governor Resume Switch

Switch signal of the PTO control activator which indicates that the activator is in the position to "resume" a previously established PTO governor set speed.

00 - Off
01 - On
10 - Error
11 - Not available

Data Length: 2 bits
Resolution: 4 states/2 bit, 0 offset
Data Range: 0 to 3 Operational Range: same as data range
Type: Measured
Supporting information:
PGN 65264

SPN 983 Engine PTO Governor Coast/Decelerate Switch

Switch signal of the PTO control activator which indicates that the activator is in the position to "coast/decelerate" the PTO governor set speed.

00 - Off
01 - On
10 - Error
11 - Not available

Data Length: 2 bits
Resolution: 4 states/2 bit, 0 offset
Data Range: 0 to 3 Operational Range: same as data range
Type: Measured
Supporting information:
PGN 65264

SPN 984 Engine PTO Governor Set Switch

Switch signal of the PTO control activator which indicates that the activator is in the position to "set" the engine PTO governor set speed.

00 - Off
01 - On
10 - Error
11 - Not available

Data Length: 2 bits
Resolution: 4 states/2 bit, 0 offset
Data Range: 0 to 3 Operational Range: same as data range
Type: Measured
Supporting information:
PGN 65264

SPN 985 A/C High Pressure Fan Switch

Switch signal which indicates that the pressure in the coolant circuit of an air conditioning system is high and the fan may be engaged.

00 - Pressure normal
01 - Pressure high, fan may be engaged
10 - Error
11 - Not available

Data Length: 2 bits
Resolution: 4 states/2 bit, 0 offset
Data Range: 0 to 3 Operational Range: same as data range
Type: Measured
Supporting information:
PGN 65252

SPN 986 Requested Percent Fan Speed

Fan speed as a ratio of the actual fan drive (current speed) to the fully engaged fan drive (maximum fan speed). A two state fan (off/on) will use 0% and 100% respectively. A three state fan (off/intermediate/on) will use 0%, 50% and 100% respectively. A variable speed fan will use 0% to 100%. Multiple fan systems will use 0 to 100% to indicate the percent cooling capacity being provided. Feedback to this request is provided using the estimated fan speed (see SPN 975).

Note that the intermediate fan speed of a three state fan will vary with different fan drives, therefore 50% is being used to indicate that the intermediate speed is required from the fan drive.

Data Length: 1 byte
Resolution: 0.4 %/bit, 0 offset
Data Range: 0 to 100 % Operational Range: same as data range
Type: Status
Supporting information:
PGN 57344

SPN 988 ***Trip Group 1***

Command signal used to reset the PGNs and parameters as defined in Table SPN988_A.

00 Take no action
01 Reset
10 Reserved
11 Not applicable

Data Length: 2 bits
Resolution: 4 states/2 bit, 0 offset
Data Range: 0 to 3 Operational Range: same as data range
Type: Status
Supporting information: See Appendix D - SPN 988
PGN 56832

SPN 989 ***Trip Group 2 - Proprietary***

Command signal used to reset proprietary parameters associated with a trip but not defined within this document.

00 Take no action
01 Reset
10 Reserved
11 Not applicable

Data Length: 2 bits
Resolution: 4 states/2 bit, 0 offset
Data Range: 0 to 3 Operational Range: same as data range
Type: Status
Supporting information:
PGN 56832

SPN 990 ***Total Compression Brake Distance***

Total distance over which the compression brakes have been active for the life of the engine.

Data Length: 4 bytes
Resolution: 0.125 km/bit, 0 offset
Data Range: 0 to 526,385,151.9 km Operational Range: same as data range
Type: Measured
Supporting information:
PGN 65212

SPN 991 ***Trip Compression Brake Distance***

Total distance over which the compression brakes have been active since the last trip reset.

Data Length: 4 bytes
Resolution: 0.125 km/bit, 0 offset
Data Range: 0 to 526,385,151.9 km Operational Range: same as data range
Type: Measured
Supporting information:
PGN 65212

SPN 992 ***Trip Service Brake Distance***

Total distance over which the service brakes have been active since the last trip reset.

Data Length: 4 bytes
 Resolution: 0.125 km/bit, 0 offset
 Data Range: 0 to 526,385,151.9 km Operational Range: same as data range
 Type: Measured
 Supporting information:
 PGN 65212

SPN 993 ***Trip Service Brake Applications***

Total number of times the service brakes have been activated since the last trip reset. Brake applications of less than 0.5 s are not counted and lengthy brake applications (longer than 0.5 s) are counted as a single event.

NOTE - Definition and resolution shall stay the same if brakes are applied by only the tractor, only the trailer or both.

Data Length: 4 bytes
 Resolution: 1 brake appl/bit, 0 offset
 Data Range: 0 to 4,227,858,431 appl Operational Range: same as data range
 Type: Measured
 Supporting information:
 PGN 65212

SPN 994 ***Trip Fan On Time***

Total time the fan has been on (due to an automatic trigger or manual trigger) since the last trip reset. The fan could be requested to be on by the engine system, a manual switch, and/or the A/C system. Whichever system requests the fan activation first shall have the time accumulated against it. The sum total of these three values shall equal the trip fan on time.

NOTE—If the fan has been requested to be on by a component that is not one of the defined categories, this time shall be accumulated in the Engine System category by default.

Data Length: 4 bytes
 Resolution: 0.05 hr/bit, 0 offset
 Data Range: 0 to 210,554,060.75 hr Operational Range: same as data range
 Type: Measured
 Supporting information:
 PGN 65211

SPN 995 ***Trip Fan On Time Due to the Engine System***

Total time the fan has been on due to engine triggers (i.e., excluding time on due to an operator manual switch or A/C system) since the last trip reset. For the time to be accumulated against the engine system, it is necessary that it be the first to request the fan activation or it be the only system requesting fan activation.

Data Length: 4 bytes
 Resolution: 0.05 hr/bit, 0 offset
 Data Range: 0 to 210,554,060.75 hr Operational Range: same as data range
 Type: Measured
 Supporting information:
 PGN 65211

SPN 996 ***Trip Fan On Time Due to a Manual Switch***

Total time the fan has been on due to manual activation by the operator (i.e., excluding time on due to automatic triggers) since the last trip reset. For the time to be accumulated against the manual switch, it is necessary that it be the first to request the fan activation or it be the only system requesting fan activation.

Data Length: 4 bytes
 Resolution: 0.05 hr/bit, 0 offset
 Data Range: 0 to 210,554,060.75 hr Operational Range: same as data range
 Type: Measured
 Supporting information:
 PGN 65211

SPN 997 ***Trip Fan On Time Due to the A/C System***

Total time the fan has been on due to the A/C system since the last trip reset. For the time to be accumulated against the A/C system, it is necessary that it be the first to request the fan activation or it be the only system requesting fan activation.

Data Length: 4 bytes
 Resolution: 0.05 hr/bit, 0 offset
 Data Range: 0 to 210,554,060.75 hr Operational Range: same as data range
 Type: Measured
 Supporting information:
 PGN 65211

SPN 998 ***Trip Distance on VSL***

Total distance accumulated while the engine torque mode is road speed governing since the last trip reset.

Data Length: 4 bytes
 Resolution: 0.125 km/bit, 0 offset
 Data Range: 0 to 526,385,151.9 km Operational Range: same as data range
 Type: Measured
 Supporting information:
 PGN 65210

SPN 999 ***Trip Gear Down Distance***

Total distance accumulated while the vehicle has operated in the gear which is one gear down from top gear and exceeds a calibrated minimum time (typically the time to shift the transmission) since the last trip reset.

Data Length: 4 bytes
 Resolution: 0.125 km/bit, 0 offset
 Data Range: 0 to 526,385,151.9 km Operational Range: same as data range
 Type: Measured
 Supporting information:
 PGN 65210

SPN 1000 *Trip Distance in Top Gear*

Total distance accumulated while the vehicle has operated in top gear for a calibrated minimum time since the last trip reset.

Data Length: 4 bytes
 Resolution: 0.125 km/bit, 0 offset
 Data Range: 0 to 526,385,151.9 km Operational Range: same as data range
 Type: Measured
 Supporting information:
 PGN 65210

SPN 1001 *Trip Drive Fuel Used*

Total fuel consumed while the engine speed is greater than zero, vehicle speed is greater than or equal to 2 km/h, and neither the PTO or the remote PTO is controlling the engine power output, since the last trip reset.

NOTE—This parameter is intended for liquid fueled engines. See SPN 1007 for alternate resolution.

Data Length: 4 bytes
 Resolution: 0.5 L/bit, 0 offset
 Data Range: 0 to 2,105,540,607.5 L Operational Range: same as data range
 Type: Measured
 Supporting information:
 PGN 65209

SPN 1002 (R) *Trip PTO Governor Moving Fuel Used*

Total fuel consumed while either the PTO or remote PTO governors are in the hold state, the engine speed is greater than zero, and vehicle speed is greater than or equal to 2 km/h, since the last trip reset.

NOTE—This parameter is intended for liquid fueled engines. See SPN 1008 for alternate resolution.

Data Length: 4 bytes
 Resolution: 0.5 L/bit, 0 offset
 Data Range: 0 to 2,105,540,607.5 L Operational Range: same as data range
 Type: Measured
 Supporting information:
 PGN 65209

SPN 1003 (R) *Trip PTO Governor Non-moving Fuel Used*

Total fuel consumed while either the PTO or remote PTO governors are in the hold state, the engine speed is greater than zero, and vehicle speed is less than 2 km/h, since the last trip reset.

NOTE—This parameter is intended for liquid fueled engines. See SPN 1009 for alternate resolution.

Data Length: 4 bytes
 Resolution: 0.5 L/bit, 0 offset
 Data Range: 0 to 2,105,540,607.5 L Operational Range: same as data range
 Type: Measured
 Supporting information:
 PGN 65209

SPN 1004 (R) Trip Vehicle Idle Fuel Used

Total fuel consumed while neither the PTO or remote PTO governor is in the hold state, the engine speed is greater than zero, and vehicle speed is less than 2 km/h, since the last trip reset.

In marine applications, this parameter is defined as the total fuel consumed while the engine speed is greater than zero, and less than or equal to 50 RPM greater than low idle, since the last trip reset.

NOTE—This parameter is intended for liquid fueled engines. See SPN 1010 for alternate resolution.

Data Length: 4 bytes
 Resolution: 0.5 L/bit, 0 offset
 Data Range: 0 to 2,105,540,607.5 L Operational Range: same as data range
 Type: Measured
 Supporting information:
 PGN 65209

SPN 1005 Trip Cruise Fuel Used

Total fuel consumed while the engine is in the cruise hold state since the last trip reset. If both cruise control and VSL (vehicle speed limiter) are commanding the same amount of fuel, the cruise control is deemed the active torque mode and fuel will be accumulated in "trip cruise fuel used" parameter. If fuel commanded due to the accelerator pedal position is larger than fuel commanded by cruise control (e.g., accelerator override torque mode), the cruise control is not deemed the active torque mode and fuel will not be accumulated in the "trip cruise fuel used" parameter.

NOTE—This parameter is intended for liquid fueled engines. See SPN 1011 for alternate resolution.

Data Length: 4 bytes
 Resolution: 0.5 L/bit, 0 offset
 Data Range: 0 to 2,105,540,607.5 L Operational Range: same as data range
 Type: Measured
 Supporting information:
 PGN 65209

SPN 1006 (R) Trip Drive Fuel Economy

Trip drive fuel economy is equal to the distance traveled by vehicle in the drive state (engine speed greater than zero, vehicle speed greater than or equal to 2 km/h, and neither the PTO or remote PTO governors are controlling engine power output) divided by trip drive fuel used (SPN 1001), since the last trip reset.

NOTE—This parameter is intended for liquid fueled engines. See SPN 1012 for alternate resolution.

Data Length: 2 bytes
 Resolution: 1/512 km/L per bit, 0 offset
 Data Range: 0 to 125.5 km/L Operational Range: same as data range
 Type: Measured
 Supporting information:
 PGN 65209

SPN 1007 (R) Trip Drive Fuel Used (Gaseous)

Total fuel consumed while the engine speed is greater than zero, vehicle speed is greater than or equal to 2 km/h, and neither the PTO or the remote PTO governors are controlling the engine power output, since the last trip reset.

NOTE—This parameter is intended for gaseous fueled engines. See SPN 1001 for alternate resolution.

Data Length: 4 bytes
Resolution: 0.5 kg/bit, 0 offset
Data Range: 0 to 2,105,540,607.5 kg Operational Range: same as data range
Type: Measured
Supporting information:
PGN 65208

SPN 1008 (R) Trip PTO Governor Moving Fuel Used (Gaseous)

Total fuel consumed while the PTO or remote PTO governors are in the hold state, the engine speed is greater than zero, and vehicle speed is greater than or equal to 2 km/h, since the last trip reset.

NOTE—This parameter is intended for gaseous fueled engines. See SPN 1002 for alternate resolution.

Data Length: 4 bytes
Resolution: 0.5 kg/bit, 0 offset
Data Range: 0 to 2,105,540,607.5 kg Operational Range: same as data range
Type: Measured
Supporting information:
PGN 65208

SPN 1009 (R) Trip PTO Governor Non-moving Fuel Used (Gaseous)

Total fuel consumed while the PTO or remote PTO governors are in the hold state, the engine speed is greater than zero, and vehicle speed is less than to 2 km/h, since the last trip reset.

NOTE—This parameter is intended for gaseous fueled engines. See SPN 1003 for alternate resolution.

Data Length: 4 bytes
Resolution: 0.5 kg/bit, 0 offset
Data Range: 0 to 2,105,540,607.5 kg Operational Range: same as data range
Type: Measured
Supporting information:
PGN 65208

SPN 1010 (R) Trip Vehicle Idle Fuel Used (Gaseous)

Total fuel consumed while neither the PTO or remote PTO governors are active, the engine speed is greater than zero, and vehicle speed is less than to 2 km/h, since the last trip reset.

NOTE—This parameter is intended for gaseous fueled engines. See SPN 1004 for alternate resolution. Trip vehicle idle fuel while in fast idle (vehicle speed less than 2 km/h with engine speed greater than 700 rpm) shall be accumulated in the trip vehicle idle fuel category. All other fuel usage scenarios that do not fall directly in the categories defined shall be accumulated in trip drive fuel used.

Data Length: 4 bytes
Resolution: 0.5 kg/bit, 0 offset
Data Range: 0 to 2,105,540,607.5 kg Operational Range: same as data range
Type: Measured
Supporting information:
PGN 65208

SPN 1011 Trip Cruise Fuel Used (Gaseous)

Total fuel consumed while the engine is in the cruise hold state since the last trip reset. If both cruise control and VSL (vehicle speed limiter) are commanding the same amount of fuel, the cruise control is deemed the active torque mode and fuel will be accumulated in "trip cruise fuel used" parameter. If fuel commanded due to the accelerator pedal position is larger than fuel commanded by cruise control (e.g., accelerator override torque mode), the cruise control is not deemed the active torque mode and fuel will not be accumulated in the "trip cruise fuel used" parameter.

NOTE—This parameter is intended for gaseous fueled engines. See SPN 1005 for alternate resolution.

Data Length: 4 bytes
 Resolution: 0.5 kg/bit, 0 offset
 Data Range: 0 to 2,105,540,607.5 kg Operational Range: same as data range
 Type: Measured
 Supporting information:
 PGN 65208

SPN 1012 (R) Trip Drive Fuel Economy (Gaseous)

Trip drive fuel economy is equal to the distance traveled by vehicle in the drive state (engine speed greater than zero, vehicle speed greater than or equal to 2 km/h, and neither the PTO or remote PTO governors are controlling engine power output) divided by trip drive fuel used (SPN 1007), since the last trip reset.

NOTE—This parameter is intended for gaseous fueled engines. See SPN 1006 for alternate resolution.

Data Length: 2 bytes
 Resolution: 1/512 km/kg per bit, 0 offset
 Data Range: 0 to 125.5 km/kg Operational Range: same as data range
 Type: Measured
 Supporting information:
 PGN 65208

SPN 1013 Trip Maximum Engine Speed

Maximum engine speed achieved since the last trip reset.

Data Length: 2 bytes
 Resolution: 0.125 rpm/bit, 0 offset
 Data Range: 0 to 8,031.875 rpm Operational Range: same as data range
 Type: Measured
 Supporting information:
 PGN 65207

SPN 1014 (R) Trip Average Engine Speed

Average speed of the engine since the last trip reset.

NOTE — Excludes ignition-on time without the engine speed above zero. Includes idle, engine PTO governor (moving and non-moving), and drive operation.

Data Length: 2 bytes
 Resolution: 0.125 rpm/bit, 0 offset
 Data Range: 0 to 8,031.875 rpm Operational Range: same as data range
 Type: Measured
 Supporting information: See Appendix D - SPN 1014
 PGN 65207

SPN 1015 (R) Trip Drive Average Load Factor

Average engine load factor while engine speed is greater than zero, vehicle speed is greater than or equal to 2 km/h, and both the PTO (moving/non-moving) and remote PTO governors are not in the hold state, since the last trip reset. Engine operation during cruise control operation is included.

In marine applications, this parameter is defined as the average engine load factor while engine speed is greater than zero, since last trip reset.

Data Length: 1 byte
 Resolution: 0.4 %/bit, 0 offset
 Data Range: 0 to 100 % Operational Range: same as data range
 Type: Measured
 Supporting information:
 PGN 65207

SPN 1016 (R) Total Drive Average Load Factor

Average engine load factor while engine speed is greater than zero, vehicle speed is greater than or equal to 2 km/h, and both the PTO (moving/non-moving) and remote PTO governors are not in the hold state, over the life of the engine. Engine operation during cruise control operation is included.

In marine applications, this parameter is defined as the average engine load factor while engine speed is greater than zero.

Data Length: 1 byte
 Resolution: 0.4 %/bit, 0 offset
 Data Range: 0 to 100 % Operational Range: same as data range
 Type: Measured
 Supporting information:
 PGN 65207

SPN 1017 Total Engine Cruise Time

Total time that the engine has operated in the cruise hold state, excluding time in accelerator override, over the life of the engine.

Data Length: 4 bytes
 Resolution: 0.05 hr/bit, 0 offset
 Data Range: 0 to 210,554,060.75 hr Operational Range: same as data range
 Type: Measured
 Supporting information:
 PGN 65207

SPN 1018 Trip Maximum Vehicle Speed

Maximum vehicle speed achieved while the engine speed is greater than zero and the accelerator pedal position (APS) is at a value greater than 0%, since the last trip reset.

Data Length: 2 bytes
 Resolution: 1/256 km/h per bit, 0 offset
 Data Range: 0 to 250.996 km/h Operational Range: same as data range
 Type: Measured
 Supporting information:
 PGN 65206

SPN 1019 Trip Cruise Distance

Total distance that the engine has operated in the cruise hold state, excluding time in accelerator override, since the last trip reset.

Data Length: 4 bytes
Resolution: 0.125 km/bit, 0 offset
Data Range: 0 to 526,385,151.9 km Operational Range: same as data range
Type: Measured
Supporting information:
PGN 65206

SPN 1020 Trip Number of Hot Shutdowns

Total number of hot shutdowns since the last trip reset. A hot shutdown is based on operation at high load or high engine speed or for long operating periods without allowing the engine to cool sufficiently.

Data Length: 2 bytes
Resolution: 1 count/bit, 0 offset
Data Range: 0 to 64,255 counts Operational Range: same as data range
Type: Measured
Supporting information:
PGN 65205

SPN 1021 Trip Number of Idle Shutdowns

Total number of times the engine has been shutdown due to idling too long (at normal idle or fast idle) since the last trip reset.

Data Length: 2 bytes
Resolution: 1 count/bit, 0 offset
Data Range: 0 to 64,255 counts Operational Range: same as data range
Type: Measured
Supporting information:
PGN 65205

SPN 1022 Trip Number of Idle Shutdown Overrides

Total number of times an operator disables idle shutdown to prevent an engine shutdown, since the last trip reset.

Data Length: 2 bytes
Resolution: 1 count/bit, 0 offset
Data Range: 0 to 64,255 counts Operational Range: same as data range
Type: Measured
Supporting information:
PGN 65205

SPN 1023 ***Trip Sudden Decelerations***

Total number of decelerations whenever the vehicle deceleration is more than XYZ km/h/sec (where XYZ is a calibratable threshold), since the last trip reset. A lengthy deceleration shall be counted as one sudden deceleration.

Data Length: 2 bytes
Resolution: 1 count/bit, 0 offset
Data Range: 0 to 64,255 counts Operational Range: same as data range
Type: Measured
Supporting information:
PGN 65205

SPN 1024 ***Trip Time in VSL***

Total time accumulated when the engine has operated on the vehicle speed limiter (VSL) while not in the cruise hold state, since the last trip reset. The engine torque mode is equal to road speed governor during this operation.

Data Length: 4 bytes
Resolution: 0.05 hr/bit, 0 offset
Data Range: 0 to 210,554,060.75 hr Operational Range: same as data range
Type: Measured
Supporting information:
PGN 65204

SPN 1025 ***Trip Time in Top Gear***

Total time accumulated when the vehicle has operated in top gear for a calibrated minimum time, since the last trip reset.

Data Length: 4 bytes
Resolution: 0.05 hr/bit, 0 offset
Data Range: 0 to 210,554,060.75 hr Operational Range: same as data range
Type: Measured
Supporting information:
PGN 65204

SPN 1026 ***Trip Time in Gear Down***

Total time accumulated when the vehicle has operated in one gear down from the top gear for a calibrated minimum time, since the last trip reset.

Data Length: 4 bytes
Resolution: 0.05 hr/bit, 0 offset
Data Range: 0 to 210,554,060.75 hr Operational Range: same as data range
Type: Measured
Supporting information:
PGN 65204

SPN 1027 Trip Time in Derate by Engine

Total time accumulated when the engine final fueling has been derated due to an engine protection algorithm, since the last reset.

Data Length: 4 bytes
 Resolution: 0.05 hr/bit, 0 offset
 Data Range: 0 to 210,554,060.75 hr Operational Range: same as data range
 Type: Measured
 Supporting information:
 PGN 65204

SPN 1028 (R) Total Engine PTO Governor Fuel Used

Total fuel used while the PTO or remote PTO governors are in the hold state and engine speed is above zero, over the life of the engine.

NOTE—This parameter is intended for liquid fueled engines. See SPN 1030 for alternate resolution.

Data Length: 4 bytes
 Resolution: 0.5 L/bit, 0 offset
 Data Range: 0 to 2,105,540,607.5 L Operational Range: same as data range
 Type: Measured
 Supporting information:
 PGN 65203

SPN 1029 (R) Trip Average Fuel Rate

Average fuel rate, equal to trip fuel divided by trip time while the engine speed is above zero, since the last trip reset. This includes idle, engine PTO governor (both moving and non-moving) and drive operation but excludes ignition-on time while the engine speed is at zero rpm.

NOTE—This parameter is intended for liquid fueled engines. See SPN 1031 for alternate resolution.

Data Length: 2 bytes
 Resolution: 0.05 L/h per bit, 0 offset
 Data Range: 0 to 3,212.75 L/h Operational Range: same as data range
 Type: Measured
 Supporting information:
 PGN 65203

SPN 1030 (R) Total Engine PTO Governor Fuel Used (Gaseous)

Total fuel used while the PTO or remote PTO governors are in the hold state and engine speed is above zero, over the life of the engine.

NOTE—This parameter is intended for gaseous fueled engines. See SPN 1028 for alternate resolution.

Data Length: 4 bytes
 Resolution: 0.5 kg/bit, 0 offset
 Data Range: 0 to 2,105,540,607.5 kg Operational Range: same as data range
 Type: Measured
 Supporting information:
 PGN 65202

SPN 1031 (R) Trip Average Fuel Rate (Gaseous)

Average fuel rate, equal to trip fuel divided by trip time while the engine speed is above zero, since the last trip reset. This includes idle, engine PTO governor (both moving and non-moving) and drive operation but excludes ignition-on time while the engine speed is at zero rpm.

NOTE—This parameter is intended for gaseous fueled engines. See SPN 1029 for alternate resolution.

Data Length: 2 bytes
 Resolution: 0.05 kg/h per bit, 0 offset
 Data Range: 0 to 3212.75 kg/h Operational Range: same as data range
 Type: Measured
 Supporting information:
 PGN 65202

SPN 1032 Total ECU Distance

Total distance accumulated over the life of the ECU. When the ECU is replaced this value shall be reset.

Data Length: 4 bytes
 Resolution: 0.125 km/bit, 0 offset
 Data Range: 0 to 526,385,151.9 km Operational Range: same as data range
 Type: Measured
 Supporting information:
 PGN 65201

SPN 1033 Total ECU Run Time

Total time accumulated over the life of the ECU, from ignition switch ON to ignition switch OFF. When the ECU is replaced this value shall be reset.

Data Length: 4 bytes
 Resolution: 0.05 hr/bit, 0 offset
 Data Range: 0 to 210,554,060.75 hr Operational Range: same as data range
 Type: Measured
 Supporting information:
 PGN 65201

SPN 1034 Trip Cruise Time

Total time accumulated while the engine is in the cruise hold state, excluding time in accelerator override, since the last trip reset.

Data Length: 4 bytes
 Resolution: 0.05 hr/bit, 0 offset
 Data Range: 0 to 210,554,060.75 hr Operational Range: same as data range
 Type: Measured
 Supporting information:
 PGN 65200

SPN 1035 (R) Trip PTO Governor Time

Total time accumulated while the engine is in the PTO or remote PTO governor hold state since the last trip reset.

Data Length: 4 bytes

Resolution: 0.05 hr/bit, 0 offset

Data Range: 0 to 210,554,060.75 hr Operational Range: same as data range

Type: Measured

Supporting information:

PGN 65200

SPN 1036 Trip Engine Running Time

Total time accumulated while the engine speed is greater than zero since the last trip reset. Note that time with the ignition switch on but engine speed at zero is not included.

Data Length: 4 bytes

Resolution: 0.05 hr/bit, 0 offset

Data Range: 0 to 210,554,060.75 hr Operational Range: same as data range

Type: Measured

Supporting information:

PGN 65200

SPN 1037 (R) Trip Idle Time

Total time accumulated while the engine speed is greater than zero, both the PTO and remote PTO governors are inactive, and the vehicle speed is less than 2 km/h, since the last trip reset.

In marine applications, this parameter is defined as the total time accumulated while the engine speed is greater than zero, and less than or equal to 50 RPM greater than low idle, since the last trip reset.

Data Length: 4 bytes

Resolution: 0.05 hr/bit, 0 offset

Data Range: 0 to 210,554,060.75 hr Operational Range: same as data range

Type: Measured

Supporting information:

PGN 65200

SPN 1038 Trip Air Compressor On Time

Total time that the air compressor is on and compressing air since the last trip reset.

Data Length: 4 bytes

Resolution: 0.05 hr/bit, 0 offset

Data Range: 0 to 210,554,060.75 hr Operational Range: same as data range

Type: Measured

Supporting information:

PGN 65200

SPN 1039 (R) Trip Fuel (Gaseous)

Total fuel consumed (trip drive fuel + trip PTO governor moving fuel + trip PTO governor non-moving fuel + trip idle fuel) since the last trip reset.

Data Length: 4 bytes
Resolution: 0.5 kg/bit, 0 offset
Data Range: 0 to 2,105,540,607.5 kg Operational Range: same as data range
Type: Measured
Supporting information:
PGN 65199

SPN 1040 (R) Total Fuel Used (Gaseous)

Total fuel consumed (trip drive fuel + trip PTO governor moving fuel + trip PTO governor non-moving fuel + trip idle fuel) over the life of the engine.

Data Length: 4 bytes
Resolution: 0.5 kg/bit, 0 offset
Data Range: 0 to 2,105,540,607.5 kg Operational Range: same as data range
Type: Measured
Supporting information:
PGN 65199

SPN 1081 Engine Wait to Start Lamp

Lamp signal which indicates that the engine is too cold to start and the operator should wait until the signal becomes inactive (turns off).

00 - Off
01 - On
10 - Error
11 - Not available

Data Length: 2 bits
Resolution: 4 states/2 bit, 0 offset
Data Range: 0 to 3 Operational Range: same as data range
Type: Status
Supporting information:
PGN 65252

SPN 1082 Engine Coolant Load Increase

Status of an event, external to the engine, that may increase the nominal temperature of the engine coolant liquid.

00 - No coolant load increase
01 - Coolant load increase possible
10 - Error
11 - Not available

Data Length: 2 bits
Resolution: 4 states/2 bit, 0 offset
Data Range: 0 to 3 Operational Range: same as data range
Type: Status
Supporting information:
PGN 61440

SPN 1083 Auxiliary I/O Channel #1

Auxiliary channel of data (16 bit) read by the ECU. This data is in A/D counts and is manufacturer specific. It may be configured uniquely per application.

Data Length: 2 bytes
 Resolution: 1 count/bit, 0 offset
 Data Range: 0 to 64,255 counts Operational Range: same as data range
 Type: Measured
 Supporting information:
 PGN 65241

SPN 1084 Auxiliary I/O Channel #2

Auxiliary channel of data (16 bit) read by the ECU. This data is in A/D counts and is manufacturer specific. It may be configured uniquely per application.

Data Length: 2 bytes
 Resolution: 1 count/bit, 0 offset
 Data Range: 0 to 64,255 counts Operational Range: same as data range
 Type: Measured
 Supporting information:
 PGN 65241

SPN 1085 Intended Retarder Percent Torque

Braking torque of retarder that the retarder is currently trying to achieve. This value takes into account all static limitations, but not the limitations due to the dynamic behavior of the retarder. This value, if unchanged over a certain time, can and will be reached by the actual retarder - percent torque (See SPN 520).

Data Length: 1 byte
 Resolution: 1 %/bit, -125 % offset
 Data Range: -125 to 125 % Operational Range: -125 to 0%
 Type: Status
 Supporting information: See Appendix D - SPN 1085
 PGN 61440

SPN 1086 Parking and/or Trailer Air Pressure

The pneumatic pressure in the circuit or reservoir for the parking brake and/or the trailer supply.

Data Length: 1 byte
 Resolution: 8 kPa/bit, 0 offset
 Data Range: 0 to 2,000 kPa Operational Range: same as data range
 Type: Measured
 Supporting information:
 PGN 65198

SPN 1087 Service Brake Circuit 1 Air Pressure

The pneumatic pressure in the primary service brake circuit or reservoir, supplying the rear axle.

Data Length: 1 byte

Resolution: 8 kPa/bit, 0 offset

Data Range: 0 to 2,000 kPa Operational Range: same as data range

Type: Measured

Supporting information:

PGN 65198

SPN 1088 Service Brake Circuit 2 Air Pressure

The pneumatic pressure in the secondary service brake circuit or reservoir, supplying the front axle.

Data Length: 1 byte

Resolution: 8 kPa/bit, 0 offset

Data Range: 0 to 2,000 kPa Operational Range: same as data range

Type: Measured

Supporting information:

PGN 65198

SPN 1089 Auxiliary Equipment Supply Pressure

The pneumatic pressure in the auxiliary circuit.

Data Length: 1 byte

Resolution: 8 kPa/bit, 0 offset

Data Range: 0 to 2,000 kPa Operational Range: same as data range

Type: Measured

Supporting information:

PGN 65198

SPN 1090 Air Suspension Supply Pressure

The pneumatic pressure in the circuit for the electronically controlled air suspension system.

Data Length: 1 byte

Resolution: 8 kPa/bit, 0 offset

Data Range: 0 to 2,000 kPa Operational Range: same as data range

Type: Measured

Supporting information:

PGN 65198

SPN 1091 Brake Application Pressure High Range, Front Axle, Left Wheel

The brake application pressure for the left wheel on the front axle.

Data Length: 1 byte

Resolution: 5 kPa/bit, 0 offset

Data Range: 0 to 1,250 kPa Operational Range: same as data range

Type: Measured

Supporting information:

PGN 65197

SPN 1092 Brake Application Pressure High Range, Front Axle, Right Wheel

The brake application pressure for the right wheel on the front axle.

Data Length: 1 byte

Resolution: 5 kPa/bit, 0 offset

Data Range: 0 to 1,250 kPa Operational Range: same as data range

Type: Measured

Supporting information:

PGN 65197

SPN 1093 Brake Application Pressure High Range, Rear Axle #1, Left Wheel

The brake application pressure for the left wheel on the rear axle #1.

Data Length: 1 byte

Resolution: 5 kPa/bit, 0 offset

Data Range: 0 to 1,250 kPa Operational Range: same as data range

Type: Measured

Supporting information:

PGN 65197

SPN 1094 Brake Application Pressure High Range, Rear Axle #1, Right Wheel

The brake application pressure for the right wheel on the rear axle #1.

Data Length: 1 byte

Resolution: 5 kPa/bit, 0 offset

Data Range: 0 to 1,250 kPa Operational Range: same as data range

Type: Measured

Supporting information:

PGN 65197

SPN 1095 Brake Application Pressure High Range, Rear Axle #2, Left Wheel

The brake application pressure for the left wheel on the rear axle #2.

Data Length: 1 byte

Resolution: 5 kPa/bit, 0 offset

Data Range: 0 to 1,250 kPa Operational Range: same as data range

Type: Measured

Supporting information:

PGN 65197

SPN 1096 Brake Application Pressure High Range, Rear Axle #2, Right Wheel

The brake application pressure for the right wheel on the rear axle #2.

Data Length: 1 byte

Resolution: 5 kPa/bit, 0 offset

Data Range: 0 to 1,250 kPa Operational Range: same as data range

Type: Measured

Supporting information:

PGN 65197

SPN 1097 Brake Application Pressure High Range, Rear Axle #3, Left Wheel

The brake application pressure for the left wheel on the rear axle #3.

Data Length: 1 byte

Resolution: 5 kPa/bit, 0 offset

Data Range: 0 to 1,250 kPa Operational Range: same as data range

Type: Measured

Supporting information:

PGN 65197

SPN 1098 Brake Application Pressure High Range, Rear Axle #3, Right Wheel

The brake application pressure for the right wheel on the rear axle #3.

Data Length: 1 byte

Resolution: 5 kPa/bit, 0 offset

Data Range: 0 to 1,250 kPa Operational Range: same as data range

Type: Measured

Supporting information:

PGN 65197

SPN 1099 Brake Lining Remaining, Front Axle, Left Wheel

The percentage of brake lining which can still be measured for the left wheel on the front axle. 100% represents new brake linings, 0% represents totally worn brake linings.

Data Length: 1 byte
Resolution: 0.4 %/bit, 0 offset
Data Range: 0 to 100 % Operational Range: same as data range
Type: Measured
Supporting information:
PGN 65196

SPN 1100 Brake Lining Remaining, Front Axle, Right Wheel

The percentage of brake lining which can still be measured for the right wheel on the front axle. 100% represents new brake linings, 0% represents totally worn brake linings.

Data Length: 1 byte
Resolution: 0.4 %/bit, 0 offset
Data Range: 0 to 100 % Operational Range: same as data range
Type: Measured
Supporting information:
PGN 65196

SPN 1101 Brake Lining Remaining, Rear Axle #1, Left Wheel

The percentage of brake lining which can still be measured for the left wheel on the rear axle #1. 100% represents new brake linings, 0% represents totally worn brake linings.

Data Length: 1 byte
Resolution: 0.4 %/bit, 0 offset
Data Range: 0 to 100 % Operational Range: same as data range
Type: Measured
Supporting information:
PGN 65196

SPN 1102 Brake Lining Remaining, Rear Axle #1, Right Wheel

The percentage of brake lining which can still be measured for the right wheel on the rear axle #1. 100% represents new brake linings, 0% represents totally worn brake linings.

Data Length: 1 byte
Resolution: 0.4 %/bit, 0 offset
Data Range: 0 to 100 % Operational Range: same as data range
Type: Measured
Supporting information:
PGN 65196

SPN 1103 Brake Lining Remaining, Rear Axle #2, Left Wheel

The percentage of brake lining which can still be measured for the left wheel on the rear axle #2. 100% represents new brake linings, 0% represents totally worn brake linings.

Data Length: 1 byte
Resolution: 0.4 %/bit, 0 offset
Data Range: 0 to 100 % Operational Range: same as data range
Type: Measured
Supporting information:
PGN 65196

SPN 1104 Brake Lining Remaining, Rear Axle #2, Right Wheel

The percentage of brake lining which can still be measured for the right wheel on the rear axle #2. 100% represents new brake linings, 0% represents totally worn brake linings.

Data Length: 1 byte
Resolution: 0.4 %/bit, 0 offset
Data Range: 0 to 100 % Operational Range: same as data range
Type: Measured
Supporting information:
PGN 65196

SPN 1105 Brake Lining Remaining, Rear Axle #3, Left Wheel

The percentage of brake lining which can still be measured for the left wheel on the rear axle #3. 100% represents new brake linings, 0% represents totally worn brake linings.

Data Length: 1 byte
Resolution: 0.4 %/bit, 0 offset
Data Range: 0 to 100 % Operational Range: same as data range
Type: Measured
Supporting information:
PGN 65196

SPN 1106 Brake Lining Remaining, Rear Axle #3, Right Wheel

The percentage of brake lining which can still be measured for the right wheel on the rear axle #3. 100% represents new brake linings, 0% represents totally worn brake linings.

Data Length: 1 byte
Resolution: 0.4 %/bit, 0 offset
Data Range: 0 to 100 % Operational Range: same as data range
Type: Measured
Supporting information:
PGN 65196

SPN 1107 Engine Protection System Timer State

Status signal which indicates the current mode of the engine protection system timer system. See Figure SPN1107_A.

00 - Inactive
01 - Active
10 - Error
11 - Not available

Data Length: 2 bits
Resolution: 4 states/2 bit, 0 offset
Data Range: 0 to 3 Operational Range: same as data range
Type: Status
Supporting information: See Appendix D - SPN 1107
PGN 65252

SPN 1108 Engine Protection System Timer Override

Status signal which indicates the status of the override feature of the engine protection system timer. See Figure SPN1107_A.

00 - Inactive
01 - Active
10 - Error
11 - Not available

Data Length: 2 bits
Resolution: 4 states/2 bit, 0 offset
Data Range: 0 to 3 Operational Range: same as data range
Type: Status
Supporting information:
PGN 65252

SPN 1109 Engine Protection System Approaching Shutdown

Status signal which indicates that engine shutdown is imminent. This engine protection signal can be a result of different systems failing, i.e., engine overheating. See Figure SPN1107_A.

00 - Not approaching
01 - Approaching
10 - Error
11 - Not available

Data Length: 2 bits
Resolution: 4 states/2 bit, 0 offset
Data Range: 0 to 3 Operational Range: same as data range
Type: Status
Supporting information:
PGN 65252

SPN 1110 Engine Protection System has Shutdown Engine

Status signal which indicates whether or not the engine protection system has shutdown the engine. See Figure SPN1107_A.

00 - No
 01 - Yes
 10 - Error
 11 - Not available

Data Length: 2 bits
 Resolution: 4 states/2 bit, 0 offset
 Data Range: 0 to 3 Operational Range: same as data range
 Type: Status
 Supporting information:
 PGN 65252

SPN 1111 Engine Protection System Configuration

Parameter which indicates the configuration of the engine shutdown system.

00 - Disabled in calibration
 01 - Enabled in calibration
 10 - Error
 11 - Not available

Data Length: 2 bits
 Resolution: 4 states/2 bit, 0 offset
 Data Range: 0 to 3 Operational Range: same as data range
 Type: Status
 Supporting information:
 PGN 65252

SPN 1113 Recommended Gear

The transmission calculates this gear continuously. In dangerous situations this gear may be selected to gain back vehicle control.

Data Length: 1 byte
 Resolution: 1 gear value/bit, -125 offset
 Data Range: -125 to 125 Operational Range: -125 to +125, negative values are reverse gears, positive values are forward gears, zero is neutral. 251 (0xFB) is park.
 Type: Status
 Supporting information:
 PGN 65195

SPN 1114 Lowest Possible Gear

The transmission calculates this gear continuously. Together with the highest possible gear (see SPN 1115), it enables a management computer to know the exact range of available gears.

Data Length: 1 byte
 Resolution: 1 gear value/bit, -125 offset
 Data Range: -125 to 125 Operational Range: -125 to +125, negative values are reverse gears, positive values are forward gears, zero is neutral. 251 (0xFB) is park.
 Type: Status
 Supporting information:
 PGN 65195

SPN 1115 Highest Possible Gear

The transmission calculates this gear continuously. Together with the lowest possible gear (see SPN 1114), it enables a management computer to know the exact range of available gears.

Data Length: 1 byte
 Resolution: 1 gear value/bit, -125 offset
 Data Range: -125 to 125 Operational Range: -125 to +125, negative values are reverse gears, positive values are forward gears, zero is neutral. 251 (0xFB) is park.
 Type: Status
 Supporting information:
 PGN 65195

SPN 1116 Engine Gaseous Fuel Correction Factor

A correction to a predefined gaseous fuel energy (expressed in energy per unit volume) represented as a percentage. The actual fuel energy used to control the engine is the product of the gaseous fuel correction factor and the energy of the gas.

Data Length: 1 byte
 Resolution: 1 %/bit, 0 offset
 Data Range: 0 to 250 % Operational Range: same as data range
 Type: Measured
 Supporting information:
 PGN 65194

SPN 1117 Engine Desired Rated Exhaust Oxygen

The desired amount of oxygen in the exhaust at rated conditions represented as a percentage by volume with respect to the total volume of exhaust gases leaving the engine.

Data Length: 2 bytes
 Resolution: 0.0025 %/bit, 0 offset
 Data Range: 0 to 160.6375 % Operational Range: same as data range
 Type: Measured
 Supporting information:
 PGN 65193

SPN 1118 Engine Desired Exhaust Oxygen

The desired amount of oxygen in the exhaust represented as a percentage by volume with respect to the total volume of exhaust gases leaving the engine.

Data Length: 2 bytes
 Resolution: 0.0025 %/bit, 0 offset
 Data Range: 0 to 160.6375 % Operational Range: same as data range
 Type: Measured
 Supporting information:
 PGN 65193

SPN 1119 Engine Actual Exhaust Oxygen

The actual amount of oxygen in the exhaust represented as a percentage by volume with respect to the total volume of exhaust gases leaving the engine.

Data Length: 2 bytes
Resolution: 0.0025 %/bit, 0 offset
Data Range: 0 to 160.6375 % Operational Range: same as data range
Type: Measured
Supporting information:
PGN 65193

SPN 1120 Articulation Angle

Angle of deflection of an articulated transit vehicle. A right turn is indicated with a positive angle and a left turn is indicated with a negative angle.

Data Length: 1 byte
Resolution: 1 deg/bit, -125 deg offset
Data Range: -125 to 125 deg Operational Range: same as data range
Type: Measured
Supporting information:
PGN 65192

SPN 1121 EBS Brake Switch

Switch signal which indicates that the brake pedal is being pressed. The EBS brake switch is independent of the brake light switch and has no provisions for external connections.

00 - Brake pedal is not being pressed
01 - Brake pedal is being pressed
10 - Error
11 - Not available

Data Length: 2 bits
Resolution: 4 states/2 bit, 0 offset
Data Range: 0 to 3 Operational Range: same as data range
Type: Measured
Supporting information:
PGN 61441

SPN 1122 Engine Alternator Bearing 1 Temperature

Temperature of the bearing inside the alternator. Bearing 1 is the left or rear bearing.

Data Length: 1 byte
Resolution: 1 deg C/bit, -40 deg C offset
Data Range: -40 to 210 deg C Operational Range: same as data range
Type: Measured
Supporting information:
PGN 65191

SPN 1123 Engine Alternator Bearing 2 Temperature

Temperature of the bearing inside the alternator. Bearing 2 is the right or front bearing.

Data Length: 1 byte

Resolution: 1 deg C/bit, -40 deg C offset

Data Range: -40 to 210 deg C Operational Range: same as data range

Type: Measured

Supporting information:

PGN 65191

SPN 1124 Engine Alternator Winding 1 Temperature

Temperature of the windings inside the alternator.

Data Length: 1 byte

Resolution: 1 deg C/bit, -40 deg C offset

Data Range: -40 to 210 deg C Operational Range: same as data range

Type: Measured

Supporting information:

PGN 65191

SPN 1125 Engine Alternator Winding 2 Temperature

Temperature of the windings inside the alternator.

Data Length: 1 byte

Resolution: 1 deg C/bit, -40 deg C offset

Data Range: -40 to 210 deg C Operational Range: same as data range

Type: Measured

Supporting information:

PGN 65191

SPN 1126 Engine Alternator Winding 3 Temperature

Temperature of the windings inside the alternator.

Data Length: 1 byte

Resolution: 1 deg C/bit, -40 deg C offset

Data Range: -40 to 210 deg C Operational Range: same as data range

Type: Measured

Supporting information:

PGN 65191

SPN 1127 Engine Turbocharger 1 Boost Pressure

Gage pressure of air measured downstream of the compressor discharge side of the turbocharger. See also SPN 102 for alternate range and resolution. If there is only one boost pressure to report and the range and resolution in SPN 102 is adequate, then it should be used.

Data Length: 2 bytes
Resolution: 0.125 kPa/bit, 0 offset
Data Range: 0 to +8031.875 kPa (0 to Operational Range: same as data range
Type: Measured
Supporting information:
PGN 65190

SPN 1128 Engine Turbocharger 2 Boost Pressure

Gage pressure of air measured downstream of the compressor discharge side of the turbocharger. See also SPN 102 for alternate range and resolution. If there is only one boost pressure to report and the range and resolution in SPN 102 is adequate, then it should be used.

Data Length: 2 bytes
Resolution: 0.125 kPa/bit, 0 offset
Data Range: 0 to +8031.875 kPa (0 to Operational Range: same as data range
Type: Measured
Supporting information:
PGN 65190

SPN 1129 Engine Turbocharger 3 Boost Pressure

Gage pressure of air measured downstream of the compressor discharge side of the turbocharger. See also SPN 102 for alternate range and resolution. If there is only one boost pressure to report and the range and resolution in SPN 102 is adequate, then it should be used.

Data Length: 2 bytes
Resolution: 0.125 kPa/bit, 0 offset
Data Range: 0 to +8031.875 kPa (0 to Operational Range: same as data range
Type: Measured
Supporting information:
PGN 65190

SPN 1130 Engine Turbocharger 4 Boost Pressure

Gage pressure of air measured downstream of the compressor discharge side of the turbocharger. See also SPN 102 for alternate range and resolution. If there is only one boost pressure to report and the range and resolution in SPN 102 is adequate, then it should be used.

Data Length: 2 bytes
Resolution: 0.125 kPa/bit, 0 offset
Data Range: 0 to +8031.875 kPa (0 to Operational Range: same as data range
Type: Measured
Supporting information:
PGN 65190

SPN 1131 Engine Intake Manifold 2 Temperature

Temperature of pre-combustion air found in intake manifold of engine air supply system.

Data Length: 1 byte

Resolution: 1 deg C/bit, -40 deg C offset

Data Range: -40 to 210 deg C Operational Range: same as data range

Type: Measured

Supporting information:

PGN 65189

SPN 1132 Engine Intake Manifold 3 Temperature

Temperature of pre-combustion air found in intake manifold of engine air supply system.

Data Length: 1 byte

Resolution: 1 deg C/bit, -40 deg C offset

Data Range: -40 to 210 deg C Operational Range: same as data range

Type: Measured

Supporting information:

PGN 65189

SPN 1133 Engine Intake Manifold 4 Temperature

Temperature of pre-combustion air found in intake manifold of engine air supply system.

Data Length: 1 byte

Resolution: 1 deg C/bit, -40 deg C offset

Data Range: -40 to 210 deg C Operational Range: same as data range

Type: Measured

Supporting information:

PGN 65189

SPN 1134 Engine Intercooler Thermostat Opening

The current position of the thermostat used to regulate the temperature of the engine intercooler. A value of 0% represents the thermostat being completely closed and 100% represents the thermostat being completely open.

Data Length: 1 byte

Resolution: 0.4 %/bit, 0 offset

Data Range: 0 to 100 % Operational Range: same as data range

Type: Measured

Supporting information:

PGN 65262

SPN 1135 Engine Oil Temperature 2

Temperature of the engine lubricant.

Data Length: 2 bytes

Resolution: 0.03125 deg C/bit, -273 deg C offset

Data Range: -273 to 1735 deg C Operational Range: same as data range

Type: Measured

Supporting information:

PGN 65188

SPN 1136 Engine ECU Temperature

Temperature of the engine electronic control unit.

Data Length: 2 bytes

Resolution: 0.03125 deg C/bit, -273 deg C offset

Data Range: -273 to 1735 deg C Operational Range: same as data range

Type: Measured

Supporting information:

PGN 65188

SPN 1137 Engine Exhaust Gas Port 1 Temperature

Temperature at the cylinder exhaust port of the engine.

Data Length: 2 bytes

Resolution: 0.03125 deg C/bit, -273 deg C offset

Data Range: -273 to 1735 deg C Operational Range: same as data range

Type: Measured

Supporting information:

PGN 65187

SPN 1138 Engine Exhaust Gas Port 2 Temperature

Temperature at the cylinder exhaust port of the engine.

Data Length: 2 bytes

Resolution: 0.03125 deg C/bit, -273 deg C offset

Data Range: -273 to 1735 deg C Operational Range: same as data range

Type: Measured

Supporting information:

PGN 65187

SPN 1139 Engine Exhaust Gas Port 3 Temperature

Temperature at the cylinder exhaust port of the engine.

Data Length: 2 bytes

Resolution: 0.03125 deg C/bit, -273 deg C offset

Data Range: -273 to 1735 deg C Operational Range: same as data range

Type: Measured

Supporting information:

PGN 65187

SPN 1140 Engine Exhaust Gas Port 4 Temperature

Temperature at the cylinder exhaust port of the engine.

Data Length: 2 bytes

Resolution: 0.03125 deg C/bit, -273 deg C offset

Data Range: -273 to 1735 deg C Operational Range: same as data range

Type: Measured

Supporting information:

PGN 65187

SPN 1141 Engine Exhaust Gas Port 5 Temperature

Temperature at the cylinder exhaust port of the engine.

Data Length: 2 bytes

Resolution: 0.03125 deg C/bit, -273 deg C offset

Data Range: -273 to 1735 deg C Operational Range: same as data range

Type: Measured

Supporting information:

PGN 65186

SPN 1142 Engine Exhaust Gas Port 6 Temperature

Temperature at the cylinder exhaust port of the engine.

Data Length: 2 bytes

Resolution: 0.03125 deg C/bit, -273 deg C offset

Data Range: -273 to 1735 deg C Operational Range: same as data range

Type: Measured

Supporting information:

PGN 65186

SPN 1143 Engine Exhaust Gas Port 7 Temperature

Temperature at the cylinder exhaust port of the engine.

Data Length: 2 bytes

Resolution: 0.03125 deg C/bit, -273 deg C offset

Data Range: -273 to 1735 deg C Operational Range: same as data range

Type: Measured

Supporting information:

PGN 65186

SPN 1144 Engine Exhaust Gas Port 8 Temperature

Temperature at the cylinder exhaust port of the engine.

Data Length: 2 bytes

Resolution: 0.03125 deg C/bit, -273 deg C offset

Data Range: -273 to 1735 deg C Operational Range: same as data range

Type: Measured

Supporting information:

PGN 65186

SPN 1145 Engine Exhaust Gas Port 9 Temperature

Temperature at the cylinder exhaust port of the engine.

Data Length: 2 bytes

Resolution: 0.03125 deg C/bit, -273 deg C offset

Data Range: -273 to 1735 deg C Operational Range: same as data range

Type: Measured

Supporting information:

PGN 65185

SPN 1146 Engine Exhaust Gas Port 10 Temperature

Temperature at the cylinder exhaust port of the engine.

Data Length: 2 bytes

Resolution: 0.03125 deg C/bit, -273 deg C offset

Data Range: -273 to 1735 deg C Operational Range: same as data range

Type: Measured

Supporting information:

PGN 65185

SPN 1147 Engine Exhaust Gas Port 11 Temperature

Temperature at the cylinder exhaust port of the engine.

Data Length: 2 bytes

Resolution: 0.03125 deg C/bit, -273 deg C offset

Data Range: -273 to 1735 deg C Operational Range: same as data range

Type: Measured

Supporting information:

PGN 65185

SPN 1148 Engine Exhaust Gas Port 12 Temperature

Temperature at the cylinder exhaust port of the engine.

Data Length: 2 bytes

Resolution: 0.03125 deg C/bit, -273 deg C offset

Data Range: -273 to 1735 deg C Operational Range: same as data range

Type: Measured

Supporting information:

PGN 65185

SPN 1149 Engine Exhaust Gas Port 13 Temperature

Temperature at the cylinder exhaust port of the engine.

Data Length: 2 bytes

Resolution: 0.03125 deg C/bit, -273 deg C offset

Data Range: -273 to 1735 deg C Operational Range: same as data range

Type: Measured

Supporting information:

PGN 65184

SPN 1150 Engine Exhaust Gas Port 14 Temperature

Temperature at the cylinder exhaust port of the engine.

Data Length: 2 bytes

Resolution: 0.03125 deg C/bit, -273 deg C offset

Data Range: -273 to 1735 deg C Operational Range: same as data range

Type: Measured

Supporting information:

PGN 65184

SPN 1151 Engine Exhaust Gas Port 15 Temperature

Temperature at the cylinder exhaust port of the engine.

Data Length: 2 bytes

Resolution: 0.03125 deg C/bit, -273 deg C offset

Data Range: -273 to 1735 deg C Operational Range: same as data range

Type: Measured

Supporting information:

PGN 65184

SPN 1152 Engine Exhaust Gas Port 16 Temperature

Temperature at the cylinder exhaust port of the engine.

Data Length: 2 bytes

Resolution: 0.03125 deg C/bit, -273 deg C offset

Data Range: -273 to 1735 deg C Operational Range: same as data range

Type: Measured

Supporting information:

PGN 65184

SPN 1153 Engine Exhaust Gas Port 17 Temperature

Temperature at the cylinder exhaust port of the engine.

Data Length: 2 bytes

Resolution: 0.03125 deg C/bit, -273 deg C offset

Data Range: -273 to 1735 deg C Operational Range: same as data range

Type: Measured

Supporting information:

PGN 65183

SPN 1154 Engine Exhaust Gas Port 18 Temperature

Temperature at the cylinder exhaust port of the engine.

Data Length: 2 bytes

Resolution: 0.03125 deg C/bit, -273 deg C offset

Data Range: -273 to 1735 deg C Operational Range: same as data range

Type: Measured

Supporting information:

PGN 65183

SPN 1155 Engine Exhaust Gas Port 19 Temperature

Temperature at the cylinder exhaust port of the engine.

Data Length: 2 bytes

Resolution: 0.03125 deg C/bit, -273 deg C offset

Data Range: -273 to 1735 deg C Operational Range: same as data range

Type: Measured

Supporting information:

PGN 65183

SPN 1156 Engine Exhaust Gas Port 20 Temperature

Temperature at the cylinder exhaust port of the engine.

Data Length: 2 bytes

Resolution: 0.03125 deg C/bit, -273 deg C offset

Data Range: -273 to 1735 deg C Operational Range: same as data range

Type: Measured

Supporting information:

PGN 65183

SPN 1157 Engine Main Bearing 1 Temperature

Temperature of the main bearing which supports the crankshaft of the engine.

Data Length: 2 bytes

Resolution: 0.03125 deg C/bit, -273 deg C offset

Data Range: -273 to 1735 deg C Operational Range: same as data range

Type: Measured

Supporting information:

PGN 65182

SPN 1158 Engine Main Bearing 2 Temperature

Temperature of the main bearing which supports the crankshaft of the engine.

Data Length: 2 bytes

Resolution: 0.03125 deg C/bit, -273 deg C offset

Data Range: -273 to 1735 deg C Operational Range: same as data range

Type: Measured

Supporting information:

PGN 65182

SPN 1159 Engine Main Bearing 3 Temperature

Temperature of the main bearing which supports the crankshaft of the engine.

Data Length: 2 bytes

Resolution: 0.03125 deg C/bit, -273 deg C offset

Data Range: -273 to 1735 deg C Operational Range: same as data range

Type: Measured

Supporting information:

PGN 65182

SPN 1160 Engine Main Bearing 4 Temperature

Temperature of the main bearing which supports the crankshaft of the engine.

Data Length: 2 bytes

Resolution: 0.03125 deg C/bit, -273 deg C offset

Data Range: -273 to 1735 deg C Operational Range: same as data range

Type: Measured

Supporting information:

PGN 65182

SPN 1161 Engine Main Bearing 5 Temperature

Temperature of the main bearing which supports the crankshaft of the engine.

Data Length: 2 bytes

Resolution: 0.03125 deg C/bit, -273 deg C offset

Data Range: -273 to 1735 deg C Operational Range: same as data range

Type: Measured

Supporting information:

PGN 65181

SPN 1162 Engine Main Bearing 6 Temperature

Temperature of the main bearing which supports the crankshaft of the engine.

Data Length: 2 bytes

Resolution: 0.03125 deg C/bit, -273 deg C offset

Data Range: -273 to 1735 deg C Operational Range: same as data range

Type: Measured

Supporting information:

PGN 65181

SPN 1163 Engine Main Bearing 7 Temperature

Temperature of the main bearing which supports the crankshaft of the engine.

Data Length: 2 bytes

Resolution: 0.03125 deg C/bit, -273 deg C offset

Data Range: -273 to 1735 deg C Operational Range: same as data range

Type: Measured

Supporting information:

PGN 65181

SPN 1164 Engine Main Bearing 8 Temperature

Temperature of the main bearing which supports the crankshaft of the engine.

Data Length: 2 bytes

Resolution: 0.03125 deg C/bit, -273 deg C offset

Data Range: -273 to 1735 deg C Operational Range: same as data range

Type: Measured

Supporting information:

PGN 65181

SPN 1165 Engine Main Bearing 9 Temperature

Temperature of the main bearing which supports the crankshaft of the engine.

Data Length: 2 bytes

Resolution: 0.03125 deg C/bit, -273 deg C offset

Data Range: -273 to 1735 deg C Operational Range: same as data range

Type: Measured

Supporting information:

PGN 65180

SPN 1166 Engine Main Bearing 10 Temperature

Temperature of the main bearing which supports the crankshaft of the engine.

Data Length: 2 bytes

Resolution: 0.03125 deg C/bit, -273 deg C offset

Data Range: -273 to 1735 deg C Operational Range: same as data range

Type: Measured

Supporting information:

PGN 65180

SPN 1167 Engine Main Bearing 11 Temperature

Temperature of the main bearing which supports the crankshaft of the engine.

Data Length: 2 bytes

Resolution: 0.03125 deg C/bit, -273 deg C offset

Data Range: -273 to 1735 deg C Operational Range: same as data range

Type: Measured

Supporting information:

PGN 65180

SPN 1168 Engine Turbocharger Lube Oil Pressure 2

Gage pressure of oil in turbocharger lubrication system.

Data Length: 1 byte

Resolution: 4 kPa/bit, 0 offset

Data Range: 0 to 1000 kPa Operational Range: same as data range

Type: Measured

Supporting information:

PGN 65179

SPN 1169 Engine Turbocharger 2 Speed

Rotational velocity of rotor in the turbocharger.

Data Length: 2 bytes

Resolution: 4 rpm/bit, 0 offset

Data Range: 0 to 257,020 rpm Operational Range: same as data range

Type: Measured

Supporting information:

PGN 65179

SPN 1170 Engine Turbocharger 3 Speed

Rotational velocity of rotor in the turbocharger.

Data Length: 2 bytes

Resolution: 4 rpm/bit, 0 offset

Data Range: 0 to 257,020 rpm Operational Range: same as data range

Type: Measured

Supporting information:

PGN 65179

SPN 1171 Engine Turbocharger 4 Speed

Rotational velocity of rotor in the turbocharger.

Data Length: 2 bytes

Resolution: 4 rpm/bit, 0 offset

Data Range: 0 to 257,020 rpm Operational Range: same as data range

Type: Measured

Supporting information:

PGN 65179

SPN 1172 Engine Turbocharger 1 Compressor Inlet Temperature

Temperature of the air entering the compressor side of the turbocharger.

Data Length: 2 bytes

Resolution: 0.03125 deg C/bit, -273 deg C offset

Data Range: -273 to 1735 deg C Operational Range: same as data range

Type: Measured

Supporting information:

PGN 65178

SPN 1173 Engine Turbocharger 2 Compressor Inlet Temperature

Temperature of the air entering the compressor side of the turbocharger.

Data Length: 2 bytes

Resolution: 0.03125 deg C/bit, -273 deg C offset

Data Range: -273 to 1735 deg C Operational Range: same as data range

Type: Measured

Supporting information:

PGN 65178

SPN 1174 Engine Turbocharger 3 Compressor Inlet Temperature

Temperature of the air entering the compressor side of the turbocharger.

Data Length: 2 bytes

Resolution: 0.03125 deg C/bit, -273 deg C offset

Data Range: -273 to 1735 deg C Operational Range: same as data range

Type: Measured

Supporting information:

PGN 65178

SPN 1175 Engine Turbocharger 4 Compressor Inlet Temperature

Temperature of the air entering the compressor side of the turbocharger.

Data Length: 2 bytes

Resolution: 0.03125 deg C/bit, -273 deg C offset

Data Range: -273 to 1735 deg C Operational Range: same as data range

Type: Measured

Supporting information:

PGN 65178

SPN 1176 Engine Turbocharger 1 Compressor Inlet Pressure

Gage pressure of the air entering the compressor side of the turbocharger.

Data Length: 2 bytes

Resolution: 1/128 kPa/bit, -250 kPa offset

Data Range: -250 kPa TO 251.99 kPa Operational Range: same as data range

Type: Measured

Supporting information:

PGN 65177

SPN 1177 Engine Turbocharger 2 Compressor Inlet Pressure

Gage pressure of the air entering the compressor side of the turbocharger.

Data Length: 2 bytes

Resolution: 1/128 kPa/bit, -250 kPa offset

Data Range: -250 kPa TO 251.99 kPa Operational Range: same as data range

Type: Measured

Supporting information:

PGN 65177

SPN 1178 Engine Turbocharger 3 Compressor Inlet Pressure

Gage pressure of the air entering the compressor side of the turbocharger.

Data Length: 2 bytes

Resolution: 1/128 kPa/bit, -250 kPa offset

Data Range: -250 kPa TO 251.99 kPa Operational Range: same as data range

Type: Measured

Supporting information:

PGN 65177

SPN 1179 Engine Turbocharger 4 Compressor Inlet Pressure

Gage pressure of the air entering the compressor side of the turbocharger.

Data Length: 2 bytes

Resolution: 1/128 kPa/bit, -250 kPa offset

Data Range: -250 kPa TO 251.99 kPa Operational Range: same as data range

Type: Measured

Supporting information:

PGN 65177

SPN 1180 Engine Turbocharger 1 Turbine Inlet Temperature

Temperature of the combustion by-products entering the turbine side of the turbocharger.

Data Length: 2 bytes

Resolution: 0.03125 deg C/bit, -273 deg C offset

Data Range: -273 to 1735 deg C Operational Range: same as data range

Type: Measured

Supporting information:

PGN 65176

SPN 1181 Engine Turbocharger 2 Turbine Inlet Temperature

Temperature of the combustion by-products entering the turbine side of the turbocharger.

Data Length: 2 bytes

Resolution: 0.03125 deg C/bit, -273 deg C offset

Data Range: -273 to 1735 deg C Operational Range: same as data range

Type: Measured

Supporting information:

PGN 65176

SPN 1182 Engine Turbocharger 3 Turbine Inlet Temperature

Temperature of the combustion by-products entering the turbine side of the turbocharger.

Data Length: 2 bytes

Resolution: 0.03125 deg C/bit, -273 deg C offset

Data Range: -273 to 1735 deg C Operational Range: same as data range

Type: Measured

Supporting information:

PGN 65176

SPN 1183 Engine Turbocharger 4 Turbine Inlet Temperature

Temperature of the combustion by-products entering the turbine side of the turbocharger.

Data Length: 2 bytes

Resolution: 0.03125 deg C/bit, -273 deg C offset

Data Range: -273 to 1735 deg C Operational Range: same as data range

Type: Measured

Supporting information:

PGN 65176

SPN 1184 Engine Turbocharger 1 Turbine Outlet Temperature

Temperature of the combustion by-products exiting the turbine side of the turbocharger.

Data Length: 2 bytes

Resolution: 0.03125 deg C/bit, -273 deg C offset

Data Range: -273 to 1735 deg C Operational Range: same as data range

Type: Measured

Supporting information:

PGN 65175

SPN 1185 Engine Turbocharger 2 Turbine Outlet Temperature

Temperature of the combustion by-products exiting the turbine side of the turbocharger.

Data Length: 2 bytes

Resolution: 0.03125 deg C/bit, -273 deg C offset

Data Range: -273 to 1735 deg C Operational Range: same as data range

Type: Measured

Supporting information:

PGN 65175

SPN 1186 Engine Turbocharger 3 Turbine Outlet Temperature

Temperature of the combustion by-products exiting the turbine side of the turbocharger.

Data Length: 2 bytes

Resolution: 0.03125 deg C/bit, -273 deg C offset

Data Range: -273 to 1735 deg C Operational Range: same as data range

Type: Measured

Supporting information:

PGN 65175

SPN 1187 Engine Turbocharger 4 Turbine Outlet Temperature

Temperature of the combustion by-products exiting the turbine side of the turbocharger.

Data Length: 2 bytes

Resolution: 0.03125 deg C/bit, -273 deg C offset

Data Range: -273 to 1735 deg C Operational Range: same as data range

Type: Measured

Supporting information:

PGN 65175

SPN 1188 Engine Turbocharger 1 Wastegate Drive

Position of the wastegate drive. A value of 0% represents fully closed and a value of 100% represents fully open.

Data Length: 1 byte

Resolution: 0.4 %/bit, 0 offset

Data Range: 0 to 100 % Operational Range: same as data range

Type: Measured

Supporting information:

PGN 65174

SPN 1189 Engine Turbocharger 2 Wastegate Drive

Position of the wastegate drive. A value of 0% represents fully closed and a value of 100% represents fully open.

Data Length: 1 byte

Resolution: 0.4 %/bit, 0 offset

Data Range: 0 to 100 % Operational Range: same as data range

Type: Measured

Supporting information:

PGN 65174

SPN 1190 Engine Turbocharger 3 Wastegate Drive

Position of the wastegate drive. A value of 0% represents fully closed and a value of 100% represents fully open.

Data Length: 1 byte

Resolution: 0.4 %/bit, 0 offset

Data Range: 0 to 100 % Operational Range: same as data range

Type: Measured

Supporting information:

PGN 65174

SPN 1191 Engine Turbocharger 4 Wastegate Drive

Position of the wastegate drive. A value of 0% represents fully closed and a value of 100% represents fully open.

Data Length: 1 byte
Resolution: 0.4 %/bit, 0 offset
Data Range: 0 to 100 % Operational Range: same as data range
Type: Measured
Supporting information:
PGN 65174

SPN 1192 Engine Turbocharger Wastegate Actuator Control Air Pressure

Gage pressure of the air used to control the actuator which opens and closes the wastegate valve.

Data Length: 1 byte
Resolution: 4 kPa/bit, 0 offset
Data Range: 0 to 1000 kPa Operational Range: same as data range
Type: Measured
Supporting information:
PGN 65174

SPN 1193 Engine Operation Time Since Rebuild

The time in engine operation since the last engine rebuild.

Data Length: 4 bytes
Resolution: 1 s/bit, 0 offset
Data Range: 0 to 4,211,081,215 s Operational Range: same as data range
Type: Measured
Supporting information:
PGN 65173

SPN 1194 Anti-theft Encryption Seed Present Indicator

Indicates the presence of the encryption seed random number.

00 - Random number is not present
01 - Random number is present
10 - Error
11 - Not available

Data Length: 2 bits
Resolution: 4 states/2 bit, 0 offset
Data Range: 0 to 3 Operational Range: same as data range
Type: Status
Supporting information:
PGN 56320

SPN 1195 *Anti-theft Password Valid Indicator*

Indicates the presence of a validated password.

00 - Password is not a validated password
01 - Password is a validated password
10 - Error
11 - Not available

Data Length: 2 bits
Resolution: 4 states/2 bit, 0 offset
Data Range: 0 to 3 Operational Range: same as data range
Type: Status
Supporting information:
PGN 56320

SPN 1196 *Anti-theft Component Status States*

Indicates whether or not the component can be started.

00 Unlocked
01 Locked
10 Blocked
11 Not defined

00b - Unlocked = This state indicates that the component can be started without the end user being required to enter a password.

01b - Locked = This state indicates that the component can NOT be started (i.e., Unlocked) without the end user being required to enter a password.

10b - Blocked = This state indicates that a Lock or Unlock command cannot be executed because some other algorithm or command of higher priority is commanding differently.

Data Length: 2 bits
Resolution: 4 states/2 bit, 0 offset
Data Range: 0 to 3 Operational Range: same as data range
Type: Status
Supporting information:
PGN 56320

SPN 1197 *Anti-theft Modify Password States*

This parameter is used to indicate whether a password request was successfully performed, or if the request could not be performed due to system constraints or if the request was not a valid request.

00 Ok
01 Full_of_Passwords
10 Empty_of_Passwords
11 Not_valid

00b - Ok = This state indicates that the request was successfully performed.

01b - Full_Of_Passwords = This state indicates that the component can NOT store any additional passwords in its memory.

10b - Empty_Of_Passwords = This state indicates that the component would be empty of passwords (an unacceptable condition) if the password under which the end user is logged in, is deleted. Thus the delete password command is not successfully executed.

Note that if the Delete_Password command is sent to a component that does not currently have a password the Empty_Of_Passwords state indicator shall be used.

11b - Not_Valid = This state indicates that the request is not a valid one.

Data Length: 2 bits
Resolution: 4 states/2 bit, 0 offset
Data Range: 0 to 3 Operational Range: same as data range
Type: Status
Supporting information:
PGN 56320

SPN 1198 *Anti-theft Random Number*

A seven byte random numeric code provided by the component in response to an anti-theft request. This parameter is sent as a numeric value utilizing the full range of 0 to 0xFFFFFFFFFFFFFFF. The most significant byte is sent first, not following the rules of Table 1.

Data Length: 7 bytes
Resolution: ASCII, 0 offset
Data Range: 0 to 255 per byte Operational Range: same as data range
Type: Status
Supporting information:
PGN 56320

SPN 1199 *Anti-theft Encryption Indicator States*

This parameter is used to indicate if a random number seed is being requested, or if an encrypted password is being provided to the component.

00 Encryption_Seed_Request
01 Encrypted_Code_Present
10 Not defined
11 Not_Available

00b - Encryption_Seed_Request = This state represents a request to the component to provide a random number seed.

01b - Encrypted_Code_Present = This state is used to indicate that an encrypted password is being provided to the component.

11b - Not_Available = This state is used to indicate that a random number is NOT being requested nor is an encrypted password being provided to the component.

Data Length: 2 bits

Resolution: 4 states/2 bit, 0 offset

Data Range: 0 to 3 Operational Range: same as data range

Type: Status

Supporting information:

PGN 56576

SPN 1200 *Anti-theft Desired Exit Mode States*

This parameter is used to specify the desired triggers that are to be used by the component in deciding when to transition to the Locked state.

00 Lock_Upon_Operator_Request
01 Lock_When_Key_Off
10 Not defined
11 Not_Available

00b - Lock_Upon_Operator_Request—This state is used to indicate that the end user would have to manually enter a password to Lock the engine.

01b - Lock_When_Keyoff—This state is used to indicate that the component would automatically transition to the Locked state when the end user turns off the engine (i.e. without the end user being required to manually enter the password).

11b - Not_Available—This state indicates that the option is not selectable or changeable by the operator via using current tool.

Data Length: 2 bits

Resolution: 4 states/2 bit, 0 offset

Data Range: 0 to 3 Operational Range: same as data range

Type: Status

Supporting information:

PGN 56576

SPN 1201 *Anti-theft Command States*

This parameter is used to identify the specific requests being sent to the component.

000 Add_Password
 001 Delete_Password
 010 Change_Password
 011 Lock_or_Unlock
 100 Check_Status
 101 Login
 110-111 Not defined

000b - Add_Password—This state represents a request to the component to add a password to the list of passwords that the component has stored as valid codes. This command will not be performed if the component has already stored, the maximum number of passwords that it is capable of storing. The Login command must precede this command.

001b - Delete_Password—This state represents a request to the component to delete the password (the same one used when the end-user logged in). See SPN 1197 for limitations.

010b - Change_Password—This state represents a request to the component to change the password (the same one that the end-user logged in with) to a different password, which is to be specified by the end user. The Login command must precede this command.

011b - Lock_Or_Unlock—This state represents a request to the component to change from the Locked state to the Unlocked state or from the Unlocked state to the Locked state.

100b - Check_Status—This state represents a request to check to see if the component is in the Locked or Unlocked state.

101b - Login—This state represents a request to validate the end user, before performing commands such as Add_Password and Change_Password.

Data Length: 3 bits
 Resolution: 8 states/3 bit, 0 offset
 Data Range: 0 to 7 Operational Range: same as data range
 Type: Status
 Supporting information:
 PGN 56576

SPN 1202 *Anti-theft Password Representation*

This parameter is the seven byte numeric code (i.e., 'encrypted password' or 'key') that is generated based on the encryption algorithm, the password supplied by the end user, and the random number seed given by the component. This parameter is sent as a numeric value utilizing the full range of 0 to 0xFFFFFFFFFFFFFFFF. The most significant byte is sent first, not following the rules of Table 1.

Data Length: 7 bytes
 Resolution: ASCII, 0 offset
 Data Range: 0 to 255 per byte Operational Range: same as data range
 Type: Status
 Supporting information:
 PGN 56576

SPN 1203 Engine Auxiliary Coolant Pressure

Gage pressure of coolant found in the intercooler which is located after the turbocharger.

Data Length: 1 byte

Resolution: 4 kPa/bit, 0 offset

Data Range: 0 to 1000 kPa Operational Range: same as data range

Type: Measured

Supporting information:

PGN 65172

SPN 1204 Electrical Load

Electrical power delivered by the engine to the electrical system connected to the generator.

Data Length: 2 bytes

Resolution: 0.5 kW/bit, 0 offset

Data Range: 0 to 32,127.5 kW Operational Range: same as data range

Type: Measured

Supporting information:

PGN 65171

SPN 1205 Safety Wire Status

Status signal which indicates that the safety wire has been activated. When the safety wire is activated, the engine will not operate. This is used for maintenance purposes.

00 - Safety wire has not been activated

01 - Safety wire has been activated

10 - Error

11 - Not available

Data Length: 2 bits

Resolution: 4 states/2 bit, 0 offset

Data Range: 0 to 3 Operational Range: same as data range

Type: Status

Supporting information:

PGN 65171

SPN 1206 Engine Turning Gear Engaged

Status signal which indicates that the turning gear is engaged. The turning gear is used to turn the flywheel/crankshaft, for maintenance purposes, while the engine is not running.

00 - Not engaged

01 - Engaged

10 - Error

11 - Not available

Data Length: 2 bits

Resolution: 4 states/2 bit, 0 offset

Data Range: 0 to 3 Operational Range: same as data range

Type: Measured

Supporting information:

PGN

SPN 1207 Engine ECU Temperature (OBSOLETE use SPN 1136)

Temperature of the engine electronic control unit.

(21, 1207 are not to be used - obsolete)

Data Length: 2 bytes

Resolution: 0.03125 deg C/bit, -273 deg C offset

Data Range: -273 to 1735 deg C Operational Range: same as data range

Type: Measured

Supporting information:

PGN

SPN 1208 Engine Pre-filter Oil Pressure

Gage pressure of the engine oil before the oil reaches the oil filter.

Data Length: 1 byte

Resolution: 4 kPa/bit, 0 offset

Data Range: 0 to 1000 kPa Operational Range: same as data range

Type: Measured

Supporting information:

PGN 65170

SPN 1209 Engine Exhaust Gas Pressure

Gage pressure of the exhaust gasses as measured at the turbine inlet of the turbocharger.

Data Length: 2 bytes

Resolution: 1/128 kPa/bit, -250 kPa offset

Data Range: -250 kPa TO 251.99 kPa Operational Range: same as data range

Type: Measured

Supporting information:

PGN 65170

SPN 1210 Engine Fuel Rack Position

Measured position of the engine fuel rack. A value of 0% rack represents no fueling and a value of 100% rack represents maximum fueling.

Data Length: 1 byte

Resolution: 0.4 %/bit, 0 offset

Data Range: 0 to 100 % Operational Range: same as data range

Type: Measured

Supporting information:

PGN 65170

SPN 1211 Engine Build Hours Reset

Command signal used to reset the engine rebuild hours.

00 Do not reset
01 Reset
10 Reserved
11 Take no action

Data Length: 2 bits
Resolution: 4 states/2 bit, 0 offset
Data Range: 0 to 3 Operational Range: same as data range
Type: Status
Supporting information:
PGN 56832

SPN 1212 Engine Auxiliary Coolant Temperature

Temperature of coolant found in the intercooler which is located after the turbocharger.

Data Length: 1 byte
Resolution: 1 deg C/bit, -40 deg C offset
Data Range: -40 to 210 deg C Operational Range: same as data range
Type: Measured
Supporting information:
PGN 65172

SPN 1237 Engine Shutdown Override Switch

Switch signal which indicates the position of the engine shutdown override switch. This switch function allows the operator to override an impending engine shutdown.

00 - Off
01 - On
10 - Error
11 - Not available

Data Length: 2 bits
Resolution: 4 states/2 bit, 0 offset
Data Range: 0 to 3 Operational Range: same as data range
Type: Measured
Supporting information:
PGN 65265

SPN 1238 Traction Control Override Switch

Switch signal which indicates the position of the traction control override switch. The traction control override signal disables the automatic traction control function allowing the wheels to spin.

00 - Off
01 - On
10 - Error
11 - Not available or not installed

Data Length: 2 bits
Resolution: 4 states/2 bit, 0 offset
Data Range: 0 to 3 Operational Range: same as data range
Type: Measured
Supporting information:
PGN 61441

SPN 1239 Engine Fuel Leakage 1

Status signal which indicates fuel leakage in the fuel rail of the engine. Location can be either before or after the fuel pump.

00 - no leakage detected
01 - leakage detected
10 - Error
11 - Not available

Data Length: 2 bits
Resolution: 4 states/2 bit, 0 offset
Data Range: 0 to 3 Operational Range: same as data range
Type: Status
Supporting information:
PGN 65169

SPN 1240 Engine Fuel Leakage 2

Status signal which indicates fuel leakage in the fuel rail of the engine. Location can be either before or after the fuel pump.

00 - no leakage detected
01 - leakage detected
10 - Error
11 - Not available

Data Length: 2 bits
Resolution: 4 states/2 bit, 0 offset
Data Range: 0 to 3 Operational Range: same as data range
Type: Status
Supporting information:
PGN 65169

SPN 1241 Engine Gas Mass Flow Rate 1

Gas mass flow rate delivered to an engine through its first fuel control system. See SPN 3467 for the second fuel control system.

Data Length: 2 bytes
 Resolution: 0.05 kg/h per bit, 0 offset
 Data Range: 0 to 3212.75 kg/h Operational Range: same as data range
 Type: Measured
 Supporting information:
 PGN 65170

SPN 1242 Instantaneous Estimated Brake Power

Estimate of the power developed by the engine.

Data Length: 2 bytes
 Resolution: 0.5 kW/bit, 0 offset
 Data Range: 0 to 32,127.5 kW Operational Range: same as data range
 Type: Measured
 Supporting information:
 PGN 65170

SPN 1243 ABS Fully Operational

Signal which indicates whether an ABS system is fully operational or whether its functionality is reduced by a defect or by an intended action (e.g., by activation of an ABS-off-road switch or during special diagnostic procedures). There are cases where the signal is necessary to fulfill legal regulations for special applications (e.g., switching off integrated retarders).

00 - Not Fully Operational
 01 - Fully Operational
 10 - Reserved
 11 - Not available

Data Length: 2 bits
 Resolution: 4 states/2 bit, 0 offset
 Data Range: 0 to 3 Operational Range: same as data range
 Type: Status
 Supporting information:
 PGN 61441

SPN 1244 Engine Fuel Actuator 2 Control Command

The control command to fuel actuator 2, normalized to percent, where 0% represents fully closed and 100% represents fully open. Typically, this fuel actuator is used to regulate low pressure natural gas flow rate, mixing into the air flow, which together then come into the engine. Using the standard convention for determining the position. Left/front is #1 (SPN 633) and right/rear is #2.

Data Length: 2 bytes
 Resolution: 0.0025 %/bit, 0 offset
 Data Range: 0 to 160.6375 % Operational Range: 0 to 100%
 Type: Status
 Supporting information:
 PGN 61466

SPN 1246 *Number of Engine Torque History Records*

Number of torque history records contained in the engine torque history PGN. A value of 0 is broadcast if no torque history records are stored in the ECU.

Data Length: 1 byte
Resolution: 1 record/bit, 0 offset
Data Range: 0 to 250 records Operational Range: same as data range
Type: Measured
Supporting information:
PGN 65168

SPN 1247 *Engine Power*

Advertised engine power capability. Advertised power is what a customer will find on a sales sheet for an engine with a certain calibration.

Data Length: 2 bytes
Resolution: 0.5 kW/bit, 0 offset
Data Range: 0 to 32,127.5 kW Operational Range: same as data range
Type: Measured
Supporting information:
PGN 65168

SPN 1248 *Engine Peak Torque 1*

Maximum torque output of the current ECU calibration when the engine operates on torque curve 1. For calibrations that support two torque curves, this parameter shall be assigned the value of the lower curve. For calibrations that support only one curve, this parameter should be used.

Data Length: 2 bytes
Resolution: 1 Nm/bit, 0 offset
Data Range: 0 to 64,255 Nm Operational Range: same as data range
Type: Measured
Supporting information:
PGN 65168

SPN 1249 *Engine Peak Torque 2*

Maximum torque output of the current ECU calibration when the engine operates on torque curve 2. For calibrations that support two torque curves, this parameter shall be assigned the value of the higher curve. For calibrations that support only one curve, this parameter should be set to "not available".

Data Length: 2 bytes
Resolution: 1 Nm/bit, 0 offset
Data Range: 0 to 64,255 Nm Operational Range: same as data range
Type: Measured
Supporting information:
PGN 65168

SPN 1250 Calibration Record Start Month

Calendar month timestamp when an ECU record was established.

NOTE - A value of 0 for the month is null. The value 1 identifies January; 2 identifies February; etc.

Data Length: 1 byte
Resolution: 1 month/bit, 0 offset
Data Range: 0 to 250 months Operational Range: 1 to 12 month
Type: Measured
Supporting information:
PGN 65168

SPN 1251 Calibration Record Start Day

Calendar day timestamp when an ECU record was established.

NOTE - A value of 0 for the date is null. The values 1, 2, 3, and 4 are used to identify the first day of the month; 5, 6, 7, and 8 identify the second day of the month; etc.

Data Length: 1 byte
Resolution: 0.25 days/bit, 0 offset
Data Range: 0 to 62.5 days Operational Range: 0.25 to 31.75 day
Type: Measured
Supporting information:
PGN 65168

SPN 1252 Calibration Record Start Year

Calendar year timestamp when an ECU record was established.

NOTE - A value of 0 for the year identifies the year 1985; a value of 1 identifies 1986; etc.

Data Length: 1 byte
Resolution: 1 year/bit, 1985 years offset
Data Range: 1985 to 2235 years Operational Range: 1985 to 2235 year
Type: Measured
Supporting information:
PGN 65168

SPN 1253 Calibration Record Duration Time

Duration in hours for which the engine operated in the conditions captured in the current record.

Data Length: 4 bytes
Resolution: 0.05 hr/bit, 0 offset
Data Range: 0 to 210,554,060.75 hr Operational Range: same as data range
Type: Measured
Supporting information:
PGN 65168

SPN 1254 Torque Limiting Feature Status

Status of an ECU feature which limits the torque output of the engine.

00 - Disabled
01 - Enabled
10 - Error
11 - Not available

Data Length: 2 bits
Resolution: 4 states/2 bit, 0 offset
Data Range: 0 to 3 Operational Range: same as data range
Type: Status
Supporting information:
PGN 65168

SPN 1255 Transmission Gear Ratio 1

Gear ratio value stored in the ECU that is used to define a range of transmission gears for which a limit is applied to the engine output torque. Transmission gear ratio 1 should be the numerically highest transmission gear ratio breakpoint that defines ratio ranges for torque limits.

Data Length: 2 bytes
Resolution: 0.01/bit, 0 offset
Data Range: 0 to 642.55 Operational Range: same as data range
Type: Measured
Supporting information:
PGN 65168

SPN 1256 Engine Torque Limit 1, Transmission

Limit applied to the engine output torque during vehicle operation in transmission gear ratios numerically greater than transmission gear ratio 1 (see SPN 1255).

Data Length: 2 bytes
Resolution: 1 Nm/bit, 0 offset
Data Range: 0 to 64,255 Nm Operational Range: same as data range
Type: Measured
Supporting information:
PGN 65168

SPN 1257 Transmission Gear Ratio 2

Gear ratio value stored in the ECU that is used to define a range of transmission gears for which a limit is applied to the engine output torque. Transmission gear ratio 2 should be the numerically highest transmission gear ratio breakpoint less than transmission gear ratio 1 (see SPN 1255) that defines ratio ranges for torque limits.

Data Length: 2 bytes
Resolution: 0.01/bit, 0 offset
Data Range: 0 to 642.55 Operational Range: same as data range
Type: Measured
Supporting information:
PGN 65168

SPN 1258 Engine Torque Limit 2, Transmission

Limit applied to the engine output torque during vehicle operation in transmission gear ratios numerically less than or equal to transmission gear ratio 1 (see SPN 1255) and numerically greater than transmission gear ratio 2 (see SPN 1257). For example, with transmission gear ratio 1 equal to 12.0:1 and transmission gear ratio 2 equal to 5.0:1, vehicle operation in a transmission gear with a ratio of 6.0:1 will result in the application of engine torque limit 2, transmission.

Data Length: 2 bytes
Resolution: 1 Nm/bit, 0 offset
Data Range: 0 to 64,255 Nm Operational Range: same as data range
Type: Measured
Supporting information:
PGN 65168

SPN 1259 Transmission Gear Ratio 3

Gear ratio value stored in the ECU that is used to define a range of transmission gears for which a limit is applied to the engine output torque. Transmission gear ratio 3 should be the numerically highest transmission gear ratio breakpoint less than transmission gear ratio 2 (see SPN 1257) that defines ratio ranges for torque limits.

Data Length: 2 bytes
Resolution: 0.01/bit, 0 offset
Data Range: 0 to 642.55 Operational Range: same as data range
Type: Measured
Supporting information:
PGN 65168

SPN 1260 Engine Torque Limit 3, Transmission

Limit applied to the engine output torque during vehicle operation in transmission gear ratios numerically less than or equal to transmission gear ratio 2 (see SPN 1257) and numerically greater than transmission gear ratio 3 (see SPN 1259). For example, with transmission gear ratio 2 equal to 5.0:1 and transmission gear ratio 3 equal to 2.0:1, vehicle operation in a transmission gear with a ratio of 3.0:1 will result in the application of engine torque limit 3, transmission.

Data Length: 2 bytes
Resolution: 1 Nm/bit, 0 offset
Data Range: 0 to 64,255 Nm Operational Range: same as data range
Type: Measured
Supporting information:
PGN 65168

SPN 1261 Engine Torque Limit 4, Transmission

Limit applied to the engine output torque during vehicle operation in transmission gear ratios numerically less than or equal to transmission gear ratio 3 (see SPN 1259).

Data Length: 2 bytes
Resolution: 1 Nm/bit, 0 offset
Data Range: 0 to 64,255 Nm Operational Range: same as data range
Type: Measured
Supporting information:
PGN 65168

SPN 1262 Engine Torque Limit 5, Switch

Limit applied to the engine output torque based on activation of an ECU switch input.

Data Length: 2 bytes

Resolution: 1 Nm/bit, 0 offset

Data Range: 0 to 64,255 Nm Operational Range: same as data range

Type: Measured

Supporting information:

PGN 65168

SPN 1263 Engine Torque Limit 6, Axle Input

Limit applied to the engine output torque based on the maximum allowable axle input torque. Axle input torque is calculated as the current engine torque output multiplied by the transmission gear ratio.

Data Length: 2 bytes

Resolution: 2 Nm/bit, 0 offset

Data Range: 0 to 128,510 Nm Operational Range: same as data range

Type: Measured

Supporting information:

PGN 65168

SPN 1264 Engine Extended Crankcase Blow-by Pressure - duplicate (see SPN 22)

Differential crankcase blow-by pressure as measured through a tube with a venturi.

(1264 not to be used – obsolete)

Data Length: 1 byte

Resolution: 0.05 kPa/bit, 0 offset

Data Range: 0 to 12.5 kPa Operational Range: same as data range

Type: Measured

Supporting information:

PGN

SPN 1294 Engine Spark Plug 1

The measured voltage of the spark event on Cylinder #1

Data Length: 2 bytes

Resolution: 1 V/bit, 0 offset

Data Range: 0 to 64,255 Volts Operational Range: same as data range

Type: Measured

Supporting information:

PGN 64887

SPN 1295 Engine Spark Plug 2

The measured voltage of the spark event on Cylinder #2

Data Length: 2 bytes

Resolution: 1 V/bit, 0 offset

Data Range: 0 to 64,255 Volts Operational Range: same as data range

Type: Measured

Supporting information:

PGN 64887

SPN 1296 Engine Spark Plug 3

The measured voltage of the spark event on Cylinder #3

Data Length: 2 bytes

Resolution: 1 V/bit, 0 offset

Data Range: 0 to 64,255 Volts Operational Range: same as data range

Type: Measured

Supporting information:

PGN 64887

SPN 1297 Engine Spark Plug 4

The measured voltage of the spark event on Cylinder #4

Data Length: 2 bytes

Resolution: 1 V/bit, 0 offset

Data Range: 0 to 64,255 Volts Operational Range: same as data range

Type: Measured

Supporting information:

PGN 64887

SPN 1298 Engine Spark Plug 5

The measured voltage of the spark event on Cylinder #5

Data Length: 2 bytes

Resolution: 1 V/bit, 0 offset

Data Range: 0 to 64,255 Volts Operational Range: same as data range

Type: Measured

Supporting information:

PGN 64886

SPN 1299 Engine Spark Plug 6

The measured voltage of the spark event on Cylinder #6

Data Length: 2 bytes

Resolution: 1 V/bit, 0 offset

Data Range: 0 to 64,255 Volts Operational Range: same as data range

Type: Measured

Supporting information:

PGN 64886

SPN 1300 Engine Spark Plug 7

The measured voltage of the spark event on Cylinder #7

Data Length: 2 bytes

Resolution: 1 V/bit, 0 offset

Data Range: 0 to 64,255 Volts Operational Range: same as data range

Type: Measured

Supporting information:

PGN 64886

SPN 1301 Engine Spark Plug 8

The measured voltage of the spark event on Cylinder #8

Data Length: 2 bytes

Resolution: 1 V/bit, 0 offset

Data Range: 0 to 64,255 Volts Operational Range: same as data range

Type: Measured

Supporting information:

PGN 64886

SPN 1302 Engine Spark Plug 9

The measured voltage of the spark event on Cylinder #9

Data Length: 2 bytes

Resolution: 1 V/bit, 0 offset

Data Range: 0 to 64,255 Volts Operational Range: same as data range

Type: Measured

Supporting information:

PGN 64885

SPN 1303 Engine Spark Plug 10

The measured voltage of the spark event on Cylinder #10

Data Length: 2 bytes

Resolution: 1 V/bit, 0 offset

Data Range: 0 to 64,255 Volts Operational Range: same as data range

Type: Measured

Supporting information:

PGN 64885

SPN 1304 Engine Spark Plug 11

The measured voltage of the spark event on Cylinder #11

Data Length: 2 bytes

Resolution: 1 V/bit, 0 offset

Data Range: 0 to 64,255 Volts Operational Range: same as data range

Type: Measured

Supporting information:

PGN 64885

SPN 1305 Engine Spark Plug 12

The measured voltage of the spark event on Cylinder #12

Data Length: 2 bytes

Resolution: 1 V/bit, 0 offset

Data Range: 0 to 64,255 Volts Operational Range: same as data range

Type: Measured

Supporting information:

PGN 64885

SPN 1306 Engine Spark Plug 13

The measured voltage of the spark event on Cylinder #13

Data Length: 2 bytes

Resolution: 1 V/bit, 0 offset

Data Range: 0 to 64,255 Volts Operational Range: same as data range

Type: Measured

Supporting information:

PGN 64884

SPN 1307 Engine Spark Plug 14

The measured voltage of the spark event on Cylinder #14

Data Length: 2 bytes

Resolution: 1 V/bit, 0 offset

Data Range: 0 to 64,255 Volts Operational Range: same as data range

Type: Measured

Supporting information:

PGN 64884

SPN 1308 Engine Spark Plug 15

The measured voltage of the spark event on Cylinder #15

Data Length: 2 bytes

Resolution: 1 V/bit, 0 offset

Data Range: 0 to 64,255 Volts Operational Range: same as data range

Type: Measured

Supporting information:

PGN 64884

SPN 1309 Engine Spark Plug 16

The measured voltage of the spark event on Cylinder #16

Data Length: 2 bytes

Resolution: 1 V/bit, 0 offset

Data Range: 0 to 64,255 Volts Operational Range: same as data range

Type: Measured

Supporting information:

PGN 64884

SPN 1310 Engine Spark Plug 17

The measured voltage of the spark event on Cylinder #17

Data Length: 2 bytes

Resolution: 1 V/bit, 0 offset

Data Range: 0 to 64,255 Volts Operational Range: same as data range

Type: Measured

Supporting information:

PGN 64883

SPN 1311 Engine Spark Plug 18

The measured voltage of the spark event on Cylinder #18

Data Length: 2 bytes

Resolution: 1 V/bit, 0 offset

Data Range: 0 to 64,255 Volts Operational Range: same as data range

Type: Measured

Supporting information:

PGN 64883

SPN 1312 Engine Spark Plug 19

The measured voltage of the spark event on Cylinder #19

Data Length: 2 bytes

Resolution: 1 V/bit, 0 offset

Data Range: 0 to 64,255 Volts Operational Range: same as data range

Type: Measured

Supporting information:

PGN 64883

SPN 1313 Engine Spark Plug 20

The measured voltage of the spark event on Cylinder #20

Data Length: 2 bytes

Resolution: 1 V/bit, 0 offset

Data Range: 0 to 64,255 Volts Operational Range: same as data range

Type: Measured

Supporting information:

PGN 64883

SPN 1314 Engine Spark Plug 21

The measured voltage of the spark event on Cylinder #21

Data Length: 2 bytes

Resolution: 1 V/bit, 0 offset

Data Range: 0 to 64,255 Volts Operational Range: same as data range

Type: Measured

Supporting information:

PGN 64882

SPN 1315 Engine Spark Plug 22

The measured voltage of the spark event on Cylinder #22

Data Length: 2 bytes

Resolution: 1 V/bit, 0 offset

Data Range: 0 to 64,255 Volts Operational Range: same as data range

Type: Measured

Supporting information:

PGN 64882

SPN 1316 Engine Spark Plug 23

The measured voltage of the spark event on Cylinder #23

Data Length: 2 bytes

Resolution: 1 V/bit, 0 offset

Data Range: 0 to 64,255 Volts Operational Range: same as data range

Type: Measured

Supporting information:

PGN 64882

SPN 1317 Engine Spark Plug 24

The measured voltage of the spark event on Cylinder #24

Data Length: 2 bytes

Resolution: 1 V/bit, 0 offset

Data Range: 0 to 64,255 Volts Operational Range: same as data range

Type: Measured

Supporting information:

PGN 64882

SPN 1320 Engine External Shutdown Air Supply Pressure

Pressure of the air used to shut off the fuel supply to the engine.

Data Length: 2 bytes

Resolution: 0.5 kPa/bit, 0 offset

Data Range: 0 to 32,127.5 kPa Operational Range: same as data range

Type: Measured

Supporting information:

PGN 65167

SPN 1349 Engine Injector Metering Rail 2 Pressure

The gage pressure of fuel in the metering rail #2 as delivered from the supply pump to the injector metering inlet. See Figure SPN16_A for fuel system related parameters. Although the figure does not show rail #2 it does show the relationship of rail pressure to other signals.

Data Length: 2 bytes
 Resolution: 1/256 MPa/bit, 0 offset
 Data Range: 0 to 251 Mpa Operational Range: same as data range
 Type: Measured
 Supporting information:
 PGN 65243

SPN 1350 Time Since Last Service

The vehicle operation time since the last service was performed. The type of service information is identified by the service component identification number.

Data Length: 2 bytes
 Resolution: 1 hr/bit, -32,127 hr offset
 Data Range: -32,127 to 32,128 hr Operational Range: same as data range
 Type: Measured
 Supporting information:
 PGN 65166

SPN 1351 Air Compressor Status

Indicates whether the air compressor is actively compressing air.

00 Compressor not active
 01 Compressor active
 10 Error indicator
 11 Not available

Data Length: 2 bits
 Resolution: 4 states/2 bit, 0 offset
 Data Range: 0 to 3 Operational Range: same as data range
 Type: Measured
 Supporting information:
 PGN 65198

SPN 1352 Engine Cylinder 1 Knock Level

Used to indicate the level of knock for engine cylinder 1. The level of knock is reported using a relative scale where 0% is least level of knock, and increasing levels indicate more knock until 100% indicates the most severe level of knock allowed or measurable for the engine.

Data Length: 1 byte
 Resolution: 1 %/bit, 0 offset
 Data Range: 0 to 250 % Operational Range: 0 to 100%
 Type: Status
 Supporting information:
 PGN 61463

SPN 1353 Engine Cylinder 2 Knock Level

Used to indicate the level of knock for engine cylinder 2. The level of knock is reported using a relative scale where 0% is least level of knock, and increasing levels indicate more knock until 100% indicates the most severe level of knock allowed or measurable for the engine.

Data Length: 1 byte
Resolution: 1 %/bit, 0 offset
Data Range: 0 to 250 % Operational Range: same as data range
Type: Status
Supporting information:
PGN 61463

SPN 1354 Engine Cylinder 3 Knock Level

Used to indicate the level of knock for engine cylinder 3. The level of knock is reported using a relative scale where 0% is least level of knock, and increasing levels indicate more knock until 100% indicates the most severe level of knock allowed or measurable for the engine.

Data Length: 1 byte
Resolution: 1 %/bit, 0 offset
Data Range: 0 to 250 % Operational Range: same as data range
Type: Status
Supporting information:
PGN 61463

SPN 1355 Engine Cylinder 4 Knock Level

Used to indicate the level of knock for engine cylinder 4. The level of knock is reported using a relative scale where 0% is least level of knock, and increasing levels indicate more knock until 100% indicates the most severe level of knock allowed or measurable for the engine.

Data Length: 1 byte
Resolution: 1 %/bit, 0 offset
Data Range: 0 to 250 % Operational Range: same as data range
Type: Status
Supporting information:
PGN 61463

SPN 1356 Engine Cylinder 5 Knock Level

Used to indicate the level of knock for engine cylinder 5. The level of knock is reported using a relative scale where 0% is least level of knock, and increasing levels indicate more knock until 100% indicates the most severe level of knock allowed or measurable for the engine.

Data Length: 1 byte
Resolution: 1 %/bit, 0 offset
Data Range: 0 to 250 % Operational Range: same as data range
Type: Status
Supporting information:
PGN 61463

SPN 1357 Engine Cylinder 6 Knock Level

Used to indicate the level of knock for engine cylinder 6. The level of knock is reported using a relative scale where 0% is least level of knock, and increasing levels indicate more knock until 100% indicates the most severe level of knock allowed or measurable for the engine.

Data Length: 1 byte
Resolution: 1 %/bit, 0 offset
Data Range: 0 to 250 % Operational Range: same as data range
Type: Status
Supporting information:
PGN 61463

SPN 1358 Engine Cylinder 7 Knock Level

Used to indicate the level of knock for engine cylinder 7. The level of knock is reported using a relative scale where 0% is least level of knock, and increasing levels indicate more knock until 100% indicates the most severe level of knock allowed or measurable for the engine.

Data Length: 1 byte
Resolution: 1 %/bit, 0 offset
Data Range: 0 to 250 % Operational Range: same as data range
Type: Status
Supporting information:
PGN 61463

SPN 1359 Engine Cylinder 8 Knock Level

Used to indicate the level of knock for engine cylinder 8. The level of knock is reported using a relative scale where 0% is least level of knock, and increasing levels indicate more knock until 100% indicates the most severe level of knock allowed or measurable for the engine.

Data Length: 1 byte
Resolution: 1 %/bit, 0 offset
Data Range: 0 to 250 % Operational Range: same as data range
Type: Status
Supporting information:
PGN 61463

SPN 1360 Engine Cylinder 9 Knock Level

Used to indicate the level of knock for engine cylinder 9. The level of knock is reported using a relative scale where 0% is least level of knock, and increasing levels indicate more knock until 100% indicates the most severe level of knock allowed or measurable for the engine.

Data Length: 1 byte
Resolution: 1 %/bit, 0 offset
Data Range: 0 to 250 % Operational Range: same as data range
Type: Status
Supporting information:
PGN 61464

SPN 1361 Engine Cylinder 10 Knock Level

Used to indicate the level of knock for engine cylinder 10. The level of knock is reported using a relative scale where 0% is least level of knock, and increasing levels indicate more knock until 100% indicates the most severe level of knock allowed or measurable for the engine.

Data Length: 1 byte
Resolution: 1 %/bit, 0 offset
Data Range: 0 to 250 % Operational Range: same as data range
Type: Status
Supporting information:
PGN 61464

SPN 1362 Engine Cylinder 11 Knock Level

Used to indicate the level of knock for engine cylinder 11. The level of knock is reported using a relative scale where 0% is least level of knock, and increasing levels indicate more knock until 100% indicates the most severe level of knock allowed or measurable for the engine.

Data Length: 1 byte
Resolution: 1 %/bit, 0 offset
Data Range: 0 to 250 % Operational Range: same as data range
Type: Status
Supporting information:
PGN 61464

SPN 1363 Engine Cylinder 12 Knock Level

Used to indicate the level of knock for engine cylinder 12. The level of knock is reported using a relative scale where 0% is least level of knock, and increasing levels indicate more knock until 100% indicates the most severe level of knock allowed or measurable for the engine.

Data Length: 1 byte
Resolution: 1 %/bit, 0 offset
Data Range: 0 to 250 % Operational Range: same as data range
Type: Status
Supporting information:
PGN 61464

SPN 1364 Engine Cylinder 13 Knock Level

Used to indicate the level of knock for engine cylinder 13. The level of knock is reported using a relative scale where 0% is least level of knock, and increasing levels indicate more knock until 100% indicates the most severe level of knock allowed or measurable for the engine.

Data Length: 1 byte
Resolution: 1 %/bit, 0 offset
Data Range: 0 to 250 % Operational Range: same as data range
Type: Status
Supporting information:
PGN 61464

SPN 1365 Engine Cylinder 14 Knock Level

Used to indicate the level of knock for engine cylinder 14. The level of knock is reported using a relative scale where 0% is least level of knock, and increasing levels indicate more knock until 100% indicates the most severe level of knock allowed or measurable for the engine.

Data Length: 1 byte
Resolution: 1 %/bit, 0 offset
Data Range: 0 to 250 % Operational Range: same as data range
Type: Status
Supporting information:
PGN 61464

SPN 1366 Engine Cylinder 15 Knock Level

Used to indicate the level of knock for engine cylinder 15. The level of knock is reported using a relative scale where 0% is least level of knock, and increasing levels indicate more knock until 100% indicates the most severe level of knock allowed or measurable for the engine.

Data Length: 1 byte
Resolution: 1 %/bit, 0 offset
Data Range: 0 to 250 % Operational Range: same as data range
Type: Status
Supporting information:
PGN 61464

SPN 1367 Engine Cylinder 16 Knock Level

Used to indicate the level of knock for engine cylinder 16. The level of knock is reported using a relative scale where 0% is least level of knock, and increasing levels indicate more knock until 100% indicates the most severe level of knock allowed or measurable for the engine.

Data Length: 1 byte
Resolution: 1 %/bit, 0 offset
Data Range: 0 to 250 % Operational Range: same as data range
Type: Status
Supporting information:
PGN 61464

SPN 1368 Engine Cylinder 17 Knock Level

Used to indicate the level of knock for engine cylinder 17. The level of knock is reported using a relative scale where 0% is least level of knock, and increasing levels indicate more knock until 100% indicates the most severe level of knock allowed or measurable for the engine.

Data Length: 1 byte
Resolution: 1 %/bit, 0 offset
Data Range: 0 to 250 % Operational Range: same as data range
Type: Status
Supporting information:
PGN 61465

SPN 1369 Engine Cylinder 18 Knock Level

Used to indicate the level of knock for engine cylinder 18. The level of knock is reported using a relative scale where 0% is least level of knock, and increasing levels indicate more knock until 100% indicates the most severe level of knock allowed or measurable for the engine.

Data Length: 1 byte
Resolution: 1 %/bit, 0 offset
Data Range: 0 to 250 % Operational Range: same as data range
Type: Status
Supporting information:
PGN 61465

SPN 1370 Engine Cylinder 19 Knock Level

Used to indicate the level of knock for engine cylinder 19. The level of knock is reported using a relative scale where 0% is least level of knock, and increasing levels indicate more knock until 100% indicates the most severe level of knock allowed or measurable for the engine.

Data Length: 1 byte
Resolution: 1 %/bit, 0 offset
Data Range: 0 to 250 % Operational Range: same as data range
Type: Status
Supporting information:
PGN 61465

SPN 1371 Engine Cylinder 20 Knock Level

Used to indicate the level of knock for engine cylinder 20. The level of knock is reported using a relative scale where 0% is least level of knock, and increasing levels indicate more knock until 100% indicates the most severe level of knock allowed or measurable for the engine.

Data Length: 1 byte
Resolution: 1 %/bit, 0 offset
Data Range: 0 to 250 % Operational Range: same as data range
Type: Status
Supporting information:
PGN 61465

SPN 1372 Engine Cylinder 21 Knock Level

Used to indicate the level of knock for engine cylinder 21. The level of knock is reported using a relative scale where 0% is least level of knock, and increasing levels indicate more knock until 100% indicates the most severe level of knock allowed or measurable for the engine.

Data Length: 1 byte
Resolution: 1 %/bit, 0 offset
Data Range: 0 to 250 % Operational Range: same as data range
Type: Status
Supporting information:
PGN 61465

SPN 1373 Engine Cylinder 22 Knock Level

Used to indicate the level of knock for engine cylinder 22. The level of knock is reported using a relative scale where 0% is least level of knock, and increasing levels indicate more knock until 100% indicates the most severe level of knock allowed or measurable for the engine.

Data Length: 1 byte
Resolution: 1 %/bit, 0 offset
Data Range: 0 to 250 % Operational Range: same as data range
Type: Status
Supporting information:
PGN 61465

SPN 1374 Engine Cylinder 23 Knock Level

Used to indicate the level of knock for engine cylinder 23. The level of knock is reported using a relative scale where 0% is least level of knock, and increasing levels indicate more knock until 100% indicates the most severe level of knock allowed or measurable for the engine.

Data Length: 1 byte
Resolution: 1 %/bit, 0 offset
Data Range: 0 to 250 % Operational Range: same as data range
Type: Status
Supporting information:
PGN 61465

SPN 1375 Engine Cylinder 24 Knock Level

Used to indicate the level of knock for engine cylinder 24. The level of knock is reported using a relative scale where 0% is least level of knock, and increasing levels indicate more knock until 100% indicates the most severe level of knock allowed or measurable for the engine.

Data Length: 1 byte
Resolution: 1 %/bit, 0 offset
Data Range: 0 to 250 % Operational Range: same as data range
Type: Status
Supporting information:
PGN 61465

SPN 1376 Battery 2 Potential (Voltage) (duplicate - see also SPN 444)

The voltage for isolated battery #2.

Data Length: 2 bytes
Resolution: 0.05 V/bit, 0 offset
Data Range: 0 to 3212.75 V Operational Range: same as data range
Type: Measured
Supporting information:
PGN

SPN 1377 Engine Synchronization Switch

This is the On/Off operation of the Multiple Unit Synchronization functionality. When it is enabled (i.e. On) the master engine will synchronize one or more slave engines to operate at the same speed. This switch position indicates whether this feature is disabled (off) or enabled (on).

00 Functionality is disabled (off)
01 Functionality is enabled (on)
10 Error
11 Not available or Unused

Data Length: 2 bits
Resolution: 4 states/2 bit, 0 offset
Data Range: 0 to 3 Operational Range: same as data range
Type: Measured
Supporting information:
PGN 64971

SPN 1379 Service Component Identification

Identification of component needing service. See Table SPN911_A.

Data Length: 1 byte
Resolution: 1 ID/bit, 0 offset
Data Range: 0 to 250 ID Operational Range: same as data range
Type: Measured
Supporting information:
PGN 65166

SPN 1380 Engine Oil Level Remote Reservoir

Ratio of current volume of engine oil in a remote reservoir to the maximum required volume. If a single switch (on/off) is used, 20% and 100% respectively will be used where 100% means no oil needs to be added and 20% means oil needs to be added. If two switches are used, 20%, 50%, and 100% will be used where 20% indicates the oil is critically low, 50% indicates the oil level is low, and 100% means no oil needs to be added. For continuous sensors, the actual measured percent will be used.

Data Length: 1 byte
Resolution: 0.4 %/bit, 0 offset
Data Range: 0 to 100 % Operational Range: same as data range
Type: Measured
Supporting information:
PGN 65130

SPN 1381 Engine Fuel Supply Pump Inlet Pressure

Absolute pressure of fuel at the fuel supply pump inlet. See Figures SPN16_A & SPN16_B

Data Length: 1 byte
Resolution: 2 kPa/bit, 0 offset
Data Range: 0 to 500 kPa Operational Range: same as data range
Type: Measured
Supporting information:
PGN 65130

SPN 1382 Engine Fuel Filter (suction side) Differential Pressure

Differential pressure measured across the fuel filter located between the fuel tank and the supply pump. See Figures SPN16_A and SPN16_B.

Data Length: 1 byte
Resolution: 2 kPa/bit, 0 offset
Data Range: 0 to 500 kPa Operational Range: same as data range
Type: Measured
Supporting information:
PGN 65130

SPN 1385 Auxiliary Temperature #1 (duplicate see also SPN 441)

Temperature measured by auxiliary temperature sensor #1 or #2. Not to be used in place of existing SPNs.

Data Length: 1 byte
Resolution: 1 deg C/bit, -40 deg C offset
Data Range: -40 to 210 deg C Operational Range: same as data range
Type: Measured
Supporting information:
PGN

SPN 1386 Auxiliary Temperature #2 (duplicate see also SPN 442)

Temperature measured by auxiliary temperature sensor #1 or #2. Not to be used in place of existing SPNs.

Data Length: 1 byte
Resolution: 1 deg C/bit, -40 deg C offset
Data Range: -40 to 210 deg C Operational Range: same as data range
Type: Measured
Supporting information:
PGN

SPN 1387 Auxiliary Pressure #1

Pressure measured by auxiliary pressure sensor #1. Not to be used in place of existing SPNs.

Data Length: 1 byte
Resolution: 16 kPa/bit, 0 offset
Data Range: 0 to 4000 kPa Operational Range: same as data range
Type: Measured
Supporting information:
PGN 65164

SPN 1388 Auxiliary Pressure #2

Pressure measured by auxiliary pressure sensor #2. Not to be used in place of existing SPNs.

Data Length: 1 byte

Resolution: 16 kPa/bit, 0 offset

Data Range: 0 to 4000 kPa Operational Range: same as data range

Type: Measured

Supporting information:

PGN 65164

SPN 1389 Engine Fuel Specific Gravity

This parameter conveys the specific gravity of the gaseous fuel being used by the engine. The specific gravity of the fuel can then be used to compute the density of the fuel.

Data Length: 2 bytes

Resolution: 0.0001/bit, 0 offset

Data Range: 0 to 6.4255 Operational Range: 0 to 2.0000

Type: Status

Supporting information:

PGN 65202

SPN 1390 Engine Fuel Valve 1 Inlet Absolute Pressure

The absolute pressure of gas on the inlet side of the first system control valve. See SPN 3466 for Engine Fuel Valve 2.

Data Length: 2 bytes

Resolution: 0.1 kPa/bit, 0 offset

Data Range: 0 to 6,425.5 kPa Operational Range: same as data range

Type: Measured

Supporting information:

PGN 65163

SPN 1391 Engine Fuel Valve Differential Pressure

The differential pressure between the inlet and the outlet of a gaseous fuel valve.

Data Length: 2 bytes

Resolution: 0.1 kPa/bit, 0 offset

Data Range: 0 to 6,425.5 kPa Operational Range: same as data range

Type: Measured

Supporting information:

PGN 65163

SPN 1392 Engine Air to Fuel Differential Pressure

This differential pressure between the gaseous fuel and the air intake manifold.

Data Length: 2 bytes

Resolution: 0.1 kPa/bit, 0 offset

Data Range: 0 to 6,425.5 kPa Operational Range: same as data range

Type: Measured

Supporting information:

PGN 65163

SPN 1393 Engine Cylinder #1 Ignition Transformer Secondary Output

This parameter indicates the relative intensity of the secondary output voltage of the ignition transformer.

Data Length: 1 byte

Resolution: 1 %/bit, -125 % offset

Data Range: -125 to 125 % Operational Range: same as data range

Type: Measured

Supporting information:

PGN 65160

SPN 1394 Engine Cylinder #2 Ignition Transformer Secondary Output

This parameter indicates the relative intensity of the secondary output voltage of the ignition transformer.

Data Length: 1 byte

Resolution: 1 %/bit, -125 % offset

Data Range: -125 to 125 % Operational Range: same as data range

Type: Measured

Supporting information:

PGN 65160

SPN 1395 Engine Cylinder #3 Ignition Transformer Secondary Output

This parameter indicates the relative intensity of the secondary output voltage of the ignition transformer.

Data Length: 1 byte

Resolution: 1 %/bit, -125 % offset

Data Range: -125 to 125 % Operational Range: same as data range

Type: Measured

Supporting information:

PGN 65160

SPN 1396 Engine Cylinder #4 Ignition Transformer Secondary Output

This parameter indicates the relative intensity of the secondary output voltage of the ignition transformer.

Data Length: 1 byte

Resolution: 1 %/bit, -125 % offset

Data Range: -125 to 125 % Operational Range: same as data range

Type: Measured

Supporting information:

PGN 65160

SPN 1397 Engine Cylinder #5 Ignition Transformer Secondary Output

This parameter indicates the relative intensity of the secondary output voltage of the ignition transformer.

Data Length: 1 byte

Resolution: 1 %/bit, -125 % offset

Data Range: -125 to 125 % Operational Range: same as data range

Type: Measured

Supporting information:

PGN 65160

SPN 1398 Engine Cylinder #6 Ignition Transformer Secondary Output

This parameter indicates the relative intensity of the secondary output voltage of the ignition transformer.

Data Length: 1 byte

Resolution: 1 %/bit, -125 % offset

Data Range: -125 to 125 % Operational Range: same as data range

Type: Measured

Supporting information:

PGN 65160

SPN 1399 Engine Cylinder #7 Ignition Transformer Secondary Output

This parameter indicates the relative intensity of the secondary output voltage of the ignition transformer.

Data Length: 1 byte

Resolution: 1 %/bit, -125 % offset

Data Range: -125 to 125 % Operational Range: same as data range

Type: Measured

Supporting information:

PGN 65160

SPN 1400 Engine Cylinder #8 Ignition Transformer Secondary Output

This parameter indicates the relative intensity of the secondary output voltage of the ignition transformer.

Data Length: 1 byte

Resolution: 1 %/bit, -125 % offset

Data Range: -125 to 125 % Operational Range: same as data range

Type: Measured

Supporting information:

PGN 65160

SPN 1401 Engine Cylinder #9 Ignition Transformer Secondary Output

This parameter indicates the relative intensity of the secondary output voltage of the ignition transformer.

Data Length: 1 byte

Resolution: 1 %/bit, -125 % offset

Data Range: -125 to 125 % Operational Range: same as data range

Type: Measured

Supporting information:

PGN 65161

SPN 1402 Engine Cylinder #10 Ignition Transformer Secondary Output

This parameter indicates the relative intensity of the secondary output voltage of the ignition transformer.

Data Length: 1 byte

Resolution: 1 %/bit, -125 % offset

Data Range: -125 to 125 % Operational Range: same as data range

Type: Measured

Supporting information:

PGN 65161

SPN 1403 Engine Cylinder #11 Ignition Transformer Secondary Output

This parameter indicates the relative intensity of the secondary output voltage of the ignition transformer.

Data Length: 1 byte

Resolution: 1 %/bit, -125 % offset

Data Range: -125 to 125 % Operational Range: same as data range

Type: Measured

Supporting information:

PGN 65161

SPN 1404 Engine Cylinder #12 Ignition Transformer Secondary Output

This parameter indicates the relative intensity of the secondary output voltage of the ignition transformer.

Data Length: 1 byte

Resolution: 1 %/bit, -125 % offset

Data Range: -125 to 125 % Operational Range: same as data range

Type: Measured

Supporting information:

PGN 65161

SPN 1405 Engine Cylinder #13 Ignition Transformer Secondary Output

This parameter indicates the relative intensity of the secondary output voltage of the ignition transformer.

Data Length: 1 byte

Resolution: 1 %/bit, -125 % offset

Data Range: -125 to 125 % Operational Range: same as data range

Type: Measured

Supporting information:

PGN 65161

SPN 1406 Engine Cylinder #14 Ignition Transformer Secondary Output

This parameter indicates the relative intensity of the secondary output voltage of the ignition transformer.

Data Length: 1 byte

Resolution: 1 %/bit, -125 % offset

Data Range: -125 to 125 % Operational Range: same as data range

Type: Measured

Supporting information:

PGN 65161

SPN 1407 Engine Cylinder #15 Ignition Transformer Secondary Output

This parameter indicates the relative intensity of the secondary output voltage of the ignition transformer.

Data Length: 1 byte

Resolution: 1 %/bit, -125 % offset

Data Range: -125 to 125 % Operational Range: same as data range

Type: Measured

Supporting information:

PGN 65161

SPN 1408 Engine Cylinder #16 Ignition Transformer Secondary Output

This parameter indicates the relative intensity of the secondary output voltage of the ignition transformer.

Data Length: 1 byte

Resolution: 1 %/bit, -125 % offset

Data Range: -125 to 125 % Operational Range: same as data range

Type: Measured

Supporting information:

PGN 65161

SPN 1409 Engine Cylinder #17 Ignition Transformer Secondary Output

This parameter indicates the relative intensity of the secondary output voltage of the ignition transformer.

Data Length: 1 byte

Resolution: 1 %/bit, -125 % offset

Data Range: -125 to 125 % Operational Range: same as data range

Type: Measured

Supporting information:

PGN 65162

SPN 1410 Engine Cylinder #18 Ignition Transformer Secondary Output

This parameter indicates the relative intensity of the secondary output voltage of the ignition transformer.

Data Length: 1 byte

Resolution: 1 %/bit, -125 % offset

Data Range: -125 to 125 % Operational Range: same as data range

Type: Measured

Supporting information:

PGN 65162

SPN 1411 Engine Cylinder #19 Ignition Transformer Secondary Output

This parameter indicates the relative intensity of the secondary output voltage of the ignition transformer.

Data Length: 1 byte

Resolution: 1 %/bit, -125 % offset

Data Range: -125 to 125 % Operational Range: same as data range

Type: Measured

Supporting information:

PGN 65162

SPN 1412 Engine Cylinder #20 Ignition Transformer Secondary Output

This parameter indicates the relative intensity of the secondary output voltage of the ignition transformer.

Data Length: 1 byte
Resolution: 1 %/bit, -125 % offset
Data Range: -125 to 125 % Operational Range: same as data range
Type: Measured
Supporting information:
PGN 65162

SPN 1413 Engine Cylinder #1 Ignition Timing

The ignition timing of the cylinder.

Data Length: 2 bytes
Resolution: 1/128 deg/bit, -200 deg offset
Data Range: -200 to 301.99 deg Operational Range: same as data range
Type: Status
Supporting information:
PGN 65154

SPN 1414 Engine Cylinder #2 Ignition Timing

The ignition timing of the cylinder.

Data Length: 2 bytes
Resolution: 1/128 deg/bit, -200 deg offset
Data Range: -200 to 301.99 deg Operational Range: same as data range
Type: Status
Supporting information:
PGN 65154

SPN 1415 Engine Cylinder #3 Ignition Timing

The ignition timing of the cylinder.

Data Length: 2 bytes
Resolution: 1/128 deg/bit, -200 deg offset
Data Range: -200 to 301.99 deg Operational Range: same as data range
Type: Status
Supporting information:
PGN 65154

SPN 1416 Engine Cylinder #4 Ignition Timing

The ignition timing of the cylinder.

Data Length: 2 bytes

Resolution: 1/128 deg/bit, -200 deg offset

Data Range: -200 to 301.99 deg Operational Range: same as data range

Type: Status

Supporting information:

PGN 65154

SPN 1417 Engine Cylinder #5 Ignition Timing

The ignition timing of the cylinder.

Data Length: 2 bytes

Resolution: 1/128 deg/bit, -200 deg offset

Data Range: -200 to 301.99 deg Operational Range: same as data range

Type: Status

Supporting information:

PGN 65155

SPN 1418 Engine Cylinder #6 Ignition Timing

The ignition timing of the cylinder.

Data Length: 2 bytes

Resolution: 1/128 deg/bit, -200 deg offset

Data Range: -200 to 301.99 deg Operational Range: same as data range

Type: Status

Supporting information:

PGN 65155

SPN 1419 Engine Cylinder #7 Ignition Timing

The ignition timing of the cylinder.

Data Length: 2 bytes

Resolution: 1/128 deg/bit, -200 deg offset

Data Range: -200 to 301.99 deg Operational Range: same as data range

Type: Status

Supporting information:

PGN 65155

SPN 1420 Engine Cylinder #8 Ignition Timing

The ignition timing of the cylinder.

Data Length: 2 bytes

Resolution: 1/128 deg/bit, -200 deg offset

Data Range: -200 to 301.99 deg Operational Range: same as data range

Type: Status

Supporting information:

PGN 65155

SPN 1421 Engine Cylinder #9 Ignition Timing

The ignition timing of the cylinder.

Data Length: 2 bytes

Resolution: 1/128 deg/bit, -200 deg offset

Data Range: -200 to 301.99 deg Operational Range: same as data range

Type: Status

Supporting information:

PGN 65156

SPN 1422 Engine Cylinder #10 Ignition Timing

The ignition timing of the cylinder.

Data Length: 2 bytes

Resolution: 1/128 deg/bit, -200 deg offset

Data Range: -200 to 301.99 deg Operational Range: same as data range

Type: Status

Supporting information:

PGN 65156

SPN 1423 Engine Cylinder #11 Ignition Timing

The ignition timing of the cylinder.

Data Length: 2 bytes

Resolution: 1/128 deg/bit, -200 deg offset

Data Range: -200 to 301.99 deg Operational Range: same as data range

Type: Status

Supporting information:

PGN 65156

SPN 1424 Engine Cylinder #12 Ignition Timing

The ignition timing of the cylinder.

Data Length: 2 bytes

Resolution: 1/128 deg/bit, -200 deg offset

Data Range: -200 to 301.99 deg Operational Range: same as data range

Type: Status

Supporting information:

PGN 65156

SPN 1425 Engine Cylinder #13 Ignition Timing

The ignition timing of the cylinder.

Data Length: 2 bytes

Resolution: 1/128 deg/bit, -200 deg offset

Data Range: -200 to 301.99 deg Operational Range: same as data range

Type: Status

Supporting information:

PGN 65157

SPN 1426 Engine Cylinder #14 Ignition Timing

The ignition timing of the cylinder.

Data Length: 2 bytes

Resolution: 1/128 deg/bit, -200 deg offset

Data Range: -200 to 301.99 deg Operational Range: same as data range

Type: Status

Supporting information:

PGN 65157

SPN 1427 Engine Cylinder #15 Ignition Timing

The ignition timing of the cylinder.

Data Length: 2 bytes

Resolution: 1/128 deg/bit, -200 deg offset

Data Range: -200 to 301.99 deg Operational Range: same as data range

Type: Status

Supporting information:

PGN 65157

SPN 1428 Engine Cylinder #16 Ignition Timing

The ignition timing of the cylinder.

Data Length: 2 bytes

Resolution: 1/128 deg/bit, -200 deg offset

Data Range: -200 to 301.99 deg Operational Range: same as data range

Type: Status

Supporting information:

PGN 65157

SPN 1429 Engine Cylinder #17 Ignition Timing

The ignition timing of the cylinder.

Data Length: 2 bytes

Resolution: 1/128 deg/bit, -200 deg offset

Data Range: -200 to 301.99 deg Operational Range: same as data range

Type: Status

Supporting information:

PGN 65158

SPN 1430 Engine Cylinder #18 Ignition Timing

The ignition timing of the cylinder.

Data Length: 2 bytes

Resolution: 1/128 deg/bit, -200 deg offset

Data Range: -200 to 301.99 deg Operational Range: same as data range

Type: Status

Supporting information:

PGN 65158

SPN 1431 Engine Cylinder #19 Ignition Timing

The ignition timing of the cylinder.

Data Length: 2 bytes

Resolution: 1/128 deg/bit, -200 deg offset

Data Range: -200 to 301.99 deg Operational Range: same as data range

Type: Status

Supporting information:

PGN 65158

SPN 1432 Engine Cylinder #20 Ignition Timing

The ignition timing of the cylinder.

Data Length: 2 bytes

Resolution: 1/128 deg/bit, -200 deg offset

Data Range: -200 to 301.99 deg Operational Range: same as data range

Type: Status

Supporting information:

PGN 65158

SPN 1433 Engine Desired Ignition Timing #1

A programmable timing value specific to the engine's application. Factors affecting this value include both fuel type and the nature of the load being driven.

Data Length: 2 bytes

Resolution: 1/128 deg/bit, -200 deg offset

Data Range: -200 to 301.99 deg Operational Range: same as data range

Type: Status

Supporting information:

PGN 65159

SPN 1434 Engine Desired Ignition Timing #2

A programmable timing value specific to the engine's application. Factors affecting this value include both fuel type and the nature of the load being driven.

Data Length: 2 bytes

Resolution: 1/128 deg/bit, -200 deg offset

Data Range: -200 to 301.99 deg Operational Range: same as data range

Type: Status

Supporting information:

PGN 65159

SPN 1435 Engine Desired Ignition Timing #3

A programmable timing value specific to the engine's application. Factors affecting this value include both fuel type and the nature of the load being driven.

Data Length: 2 bytes

Resolution: 1/128 deg/bit, -200 deg offset

Data Range: -200 to 301.99 deg Operational Range: same as data range

Type: Status

Supporting information:

PGN 65159

SPN 1436 Engine Actual Ignition Timing

The actual ignition timing at the current engine conditions. This parameter may or may not be equal to one of the desired timing parameters (see SPNs 1433-1435), depending on the status of the engine.

Data Length: 2 bytes
Resolution: 1/128 deg/bit, -200 deg offset
Data Range: -200 to 301.99 deg Operational Range: same as data range
Type: Status
Supporting information:
PGN 65159

SPN 1437 Road Speed Limit Status

Status (active or not active) of the system used to limit maximum vehicle velocity.

00 - Active
01 - Not Active
10 - Error
11 - Not available

NOTE - While somewhat inconsistent with other J1939 status parameters, the states defining 00 = active and 01 = inactive for Road Speed Limit Status are NOT typographical errors, and should be implemented as stated.

Data Length: 2 bits
Resolution: 4 states/2 bit, 0 offset
Data Range: 0 to 3 Operational Range: same as data range
Type: Status
Supporting information:
PGN 61443

SPN 1438 ABS/EBS Amber Warning Signal (Powered Vehicle)

This parameter commands the ABS/EBS amber/yellow optical warning signal

00 Off
01 On
10 Reserved
11 Take no action

Data Length: 2 bits
Resolution: 4 states/2 bit, 0 offset
Data Range: 0 to 3 Operational Range: same as data range
Type: Status
Supporting information:
PGN 61441

SPN 1439 EBS Red Warning Signal

This parameter commands the EBS red optical warning signal

00 Off
01 On
10 Reserved
11 Take no action

Data Length: 2 bits
Resolution: 4 states/2 bit, 0 offset
Data Range: 0 to 3 Operational Range: same as data range
Type: Status
Supporting information:
PGN 61441

SPN 1440 Engine Fuel Flow Rate 1

The rate at which the fuel is flowing through a fuel valve.

Data Length: 2 bytes
Resolution: 0.1 m³/h per bit, 0 offset
Data Range: 0 to 6425.5 m³/h Operational Range: same as data range
Type: Measured
Supporting information:
PGN 65153

SPN 1441 Engine Fuel Flow Rate 2

The rate at which the fuel is flowing through a fuel valve.

Data Length: 2 bytes
Resolution: 0.1 m³/h per bit, 0 offset
Data Range: 0 to 6425.5 m³/h Operational Range: same as data range
Type: Measured
Supporting information:
PGN 65153

SPN 1442 Engine Fuel Valve 1 Position

The position of a gaseous fuel valve that is metering the fuel flow to the engine. 0% indicates no fuel flow through valve and 100% means maximum fuel flow through valve.

Data Length: 1 byte
Resolution: 0.4 %/bit, 0 offset
Data Range: 0 to 100 % Operational Range: same as data range
Type: Measured
Supporting information:
PGN 65153

SPN 1443 Engine Fuel Valve 2 Position

The position of a gaseous fuel valve that is metering the fuel flow to the engine. 0% indicates no fuel flow through valve and 100% means maximum fuel flow through valve.

Data Length: 1 byte
Resolution: 0.4 %/bit, 0 offset
Data Range: 0 to 100 % Operational Range: same as data range
Type: Measured
Supporting information:
PGN 65153

SPN 1444 Engine Cylinder #1 Combustion Time

The amount of time from when the ignition of the fuel is initiated to when the fuel is completely ignited (i.e., the flame front has propagated across the cylinder).

Data Length: 2 bytes
Resolution: 0.01 ms/bit, 0 offset
Data Range: 0 to 642.55 ms Operational Range: same as data range
Type: Measured
Supporting information:
PGN 65147

SPN 1445 Engine Cylinder #2 Combustion Time

The amount of time from when the ignition of the fuel is initiated to when the fuel is completely ignited (i.e., the flame front has propagated across the cylinder).

Data Length: 2 bytes
Resolution: 0.01 ms/bit, 0 offset
Data Range: 0 to 642.55 ms Operational Range: same as data range
Type: Measured
Supporting information:
PGN 65147

SPN 1446 Engine Cylinder #3 Combustion Time

The amount of time from when the ignition of the fuel is initiated to when the fuel is completely ignited (i.e., the flame front has propagated across the cylinder).

Data Length: 2 bytes
Resolution: 0.01 ms/bit, 0 offset
Data Range: 0 to 642.55 ms Operational Range: same as data range
Type: Measured
Supporting information:
PGN 65147

SPN 1447 Engine Cylinder #4 Combustion Time

The amount of time from when the ignition of the fuel is initiated to when the fuel is completely ignited (i.e., the flame front has propagated across the cylinder).

Data Length: 2 bytes

Resolution: 0.01 ms/bit, 0 offset

Data Range: 0 to 642.55 ms Operational Range: same as data range

Type: Measured

Supporting information:

PGN 65147

SPN 1448 Engine Cylinder #5 Combustion Time

The amount of time from when the ignition of the fuel is initiated to when the fuel is completely ignited (i.e., the flame front has propagated across the cylinder).

Data Length: 2 bytes

Resolution: 0.01 ms/bit, 0 offset

Data Range: 0 to 642.55 ms Operational Range: same as data range

Type: Measured

Supporting information:

PGN 65148

SPN 1449 Engine Cylinder #6 Combustion Time

The amount of time from when the ignition of the fuel is initiated to when the fuel is completely ignited (i.e., the flame front has propagated across the cylinder).

Data Length: 2 bytes

Resolution: 0.01 ms/bit, 0 offset

Data Range: 0 to 642.55 ms Operational Range: same as data range

Type: Measured

Supporting information:

PGN 65148

SPN 1450 Engine Cylinder #7 Combustion Time

The amount of time from when the ignition of the fuel is initiated to when the fuel is completely ignited (i.e., the flame front has propagated across the cylinder).

Data Length: 2 bytes

Resolution: 0.01 ms/bit, 0 offset

Data Range: 0 to 642.55 ms Operational Range: same as data range

Type: Measured

Supporting information:

PGN 65148

SPN 1451 Engine Cylinder #8 Combustion Time

The amount of time from when the ignition of the fuel is initiated to when the fuel is completely ignited (i.e., the flame front has propagated across the cylinder).

Data Length: 2 bytes

Resolution: 0.01 ms/bit, 0 offset

Data Range: 0 to 642.55 ms Operational Range: same as data range

Type: Measured

Supporting information:

PGN 65148

SPN 1452 Engine Cylinder #9 Combustion Time

The amount of time from when the ignition of the fuel is initiated to when the fuel is completely ignited (i.e., the flame front has propagated across the cylinder).

Data Length: 2 bytes

Resolution: 0.01 ms/bit, 0 offset

Data Range: 0 to 642.55 ms Operational Range: same as data range

Type: Measured

Supporting information:

PGN 65149

SPN 1453 Engine Cylinder #10 Combustion Time

The amount of time from when the ignition of the fuel is initiated to when the fuel is completely ignited (i.e., the flame front has propagated across the cylinder).

Data Length: 2 bytes

Resolution: 0.01 ms/bit, 0 offset

Data Range: 0 to 642.55 ms Operational Range: same as data range

Type: Measured

Supporting information:

PGN 65149

SPN 1454 Engine Cylinder #11 Combustion Time

The amount of time from when the ignition of the fuel is initiated to when the fuel is completely ignited (i.e., the flame front has propagated across the cylinder).

Data Length: 2 bytes

Resolution: 0.01 ms/bit, 0 offset

Data Range: 0 to 642.55 ms Operational Range: same as data range

Type: Measured

Supporting information:

PGN 65149

SPN 1455 Engine Cylinder #12 Combustion Time

The amount of time from when the ignition of the fuel is initiated to when the fuel is completely ignited (i.e., the flame front has propagated across the cylinder).

Data Length: 2 bytes

Resolution: 0.01 ms/bit, 0 offset

Data Range: 0 to 642.55 ms Operational Range: same as data range

Type: Measured

Supporting information:

PGN 65149

SPN 1456 Engine Cylinder #13 Combustion Time

The amount of time from when the ignition of the fuel is initiated to when the fuel is completely ignited (i.e., the flame front has propagated across the cylinder).

Data Length: 2 bytes

Resolution: 0.01 ms/bit, 0 offset

Data Range: 0 to 642.55 ms Operational Range: same as data range

Type: Measured

Supporting information:

PGN 65150

SPN 1457 Engine Cylinder #14 Combustion Time

The amount of time from when the ignition of the fuel is initiated to when the fuel is completely ignited (i.e., the flame front has propagated across the cylinder).

Data Length: 2 bytes

Resolution: 0.01 ms/bit, 0 offset

Data Range: 0 to 642.55 ms Operational Range: same as data range

Type: Measured

Supporting information:

PGN 65150

SPN 1458 Engine Cylinder #15 Combustion Time

The amount of time from when the ignition of the fuel is initiated to when the fuel is completely ignited (i.e., the flame front has propagated across the cylinder).

Data Length: 2 bytes

Resolution: 0.01 ms/bit, 0 offset

Data Range: 0 to 642.55 ms Operational Range: same as data range

Type: Measured

Supporting information:

PGN 65150

SPN 1459 Engine Cylinder #16 Combustion Time

The amount of time from when the ignition of the fuel is initiated to when the fuel is completely ignited (i.e., the flame front has propagated across the cylinder).

Data Length: 2 bytes
Resolution: 0.01 ms/bit, 0 offset
Data Range: 0 to 642.55 ms Operational Range: same as data range
Type: Measured
Supporting information:
PGN 65150

SPN 1460 Engine Cylinder #17 Combustion Time

The amount of time from when the ignition of the fuel is initiated to when the fuel is completely ignited (i.e., the flame front has propagated across the cylinder).

Data Length: 2 bytes
Resolution: 0.01 ms/bit, 0 offset
Data Range: 0 to 642.55 ms Operational Range: same as data range
Type: Measured
Supporting information:
PGN 65151

SPN 1461 Engine Cylinder #18 Combustion Time

The amount of time from when the ignition of the fuel is initiated to when the fuel is completely ignited (i.e., the flame front has propagated across the cylinder).

Data Length: 2 bytes
Resolution: 0.01 ms/bit, 0 offset
Data Range: 0 to 642.55 ms Operational Range: same as data range
Type: Measured
Supporting information:
PGN 65151

SPN 1462 Engine Cylinder #19 Combustion Time

The amount of time from when the ignition of the fuel is initiated to when the fuel is completely ignited (i.e., the flame front has propagated across the cylinder).

Data Length: 2 bytes
Resolution: 0.01 ms/bit, 0 offset
Data Range: 0 to 642.55 ms Operational Range: same as data range
Type: Measured
Supporting information:
PGN 65151

SPN 1463 Engine Cylinder #20 Combustion Time

The amount of time from when the ignition of the fuel is initiated to when the fuel is completely ignited (i.e., the flame front has propagated across the cylinder).

Data Length: 2 bytes
 Resolution: 0.01 ms/bit, 0 offset
 Data Range: 0 to 642.55 ms Operational Range: same as data range
 Type: Measured
 Supporting information:
 PGN 65151

SPN 1464 Engine Desired Combustion Time

The desired combustion time based upon engine load and speed lookup maps.

Data Length: 2 bytes
 Resolution: 0.01 ms/bit, 0 offset
 Data Range: 0 to 642.55 ms Operational Range: same as data range
 Type: Measured
 Supporting information:
 PGN 65152

SPN 1465 Engine Average Combustion Time

The average combustion time of all cylinders of an engine.

Data Length: 2 bytes
 Resolution: 0.01 ms/bit, 0 offset
 Data Range: 0 to 642.55 ms Operational Range: same as data range
 Type: Measured
 Supporting information:
 PGN 65152

SPN 1466 Steer Channel Mode

Indicates the functional mode of steer channel of the tire pressure control system.

0000 Maintain
 0001 Inflate
 0010 Deflate
 0011 Confirm
 0100 Inflate Wait – System will inflate when conditions allow
 0101 Deflate Wait – System will deflate when conditions allow
 0110 Pressure Check
 0111-1101 Reserved
 1110 Error Condition
 1111 Not available

Data Length: 4 bits
 Resolution: 16 states/4 bit, 0 offset
 Data Range: 0 to 15 Operational Range: same as data range
 Type: Status
 Supporting information:
 PGN 65144

SPN 1467 Trailer/tag Channel Mode

Indicates the functional mode of trailer/tag channel of the tire pressure control system.

0000 Maintain
0001 Inflate
0010 Deflate
0011 Confirm
0100 Inflate Wait – System will inflate when conditions allow
0101 Deflate Wait – System will deflate when conditions allow
0110 Pressure Check
0111-1101 Reserved
1110 Error Condition
1111 Not available

Data Length: 4 bits
Resolution: 16 states/4 bit, 0 offset
Data Range: 0 to 15 Operational Range: same as data range
Type: Status
Supporting information:
PGN 65144

SPN 1468 Drive Channel Mode

Indicates the functional mode of trailer/tag channel of the tire pressure control system.

0000 Maintain
0001 Inflate
0010 Deflate
0011 Confirm
0100 Inflate Wait – System will inflate when conditions allow
0101 Deflate Wait – System will deflate when conditions allow
0110 Pressure Check
0111-1101 Reserved
1110 Error Condition
1111 Not available

Data Length: 4 bits
Resolution: 16 states/4 bit, 0 offset
Data Range: 0 to 15 Operational Range: same as data range
Type: Status
Supporting information:
PGN 65144

SPN 1469 PCU Drive Solenoid Status

Current state of the drive solenoid used to implement a tire pressure control system in its pneumatic control unit (PCU).

00 - Off
01 - On
10 - Error
11 - Not available

Data Length: 2 bits
Resolution: 4 states/2 bit, 0 offset
Data Range: 0 to 3 Operational Range: same as data range
Type: Status
Supporting information:
PGN 65144

SPN 1470 PCU Steer Solenoid Status

Current state of the steer solenoid used to implement a tire pressure control system in its pneumatic control unit (PCU).

00 - Off
01 - On
10 - Error
11 - Not available

Data Length: 2 bits
Resolution: 4 states/2 bit, 0 offset
Data Range: 0 to 3 Operational Range: same as data range
Type: Status
Supporting information:
PGN 65144

SPN 1471 Tire Pressure Supply Switch Status

Current state of an open/closed type switch used to determine if adequate pressure exists for system implementation.

00 - Off
01 - On
10 - Error
11 - Not available

Data Length: 2 bits
Resolution: 4 states/2 bit, 0 offset
Data Range: 0 to 3 Operational Range: same as data range
Type: Status
Supporting information:
PGN 65144

SPN 1472 PCU Deflate Solenoid Status

Current state of the deflate solenoid used to implement a tire pressure control system in its pneumatic control unit (PCU).

00 - Off
01 - On
10 - Error
11 - Not available

Data Length: 2 bits
Resolution: 4 states/2 bit, 0 offset
Data Range: 0 to 3 Operational Range: same as data range
Type: Status
Supporting information:
PGN 65144

SPN 1473 PCU Control Solenoid Status

Current state of the control solenoid used to implement a tire pressure control system in its pneumatic control unit (PCU).

00 - Off
01 - On
10 - Error
11 - Not available

Data Length: 2 bits
Resolution: 4 states/2 bit, 0 offset
Data Range: 0 to 3 Operational Range: same as data range
Type: Status
Supporting information:
PGN 65144

SPN 1474 PCU Supply Solenoid Status

Current state of the supply solenoid used to implement a tire pressure control system in its pneumatic control unit (PCU).

00 - Off
01 - On
10 - Error
11 - Not available

Data Length: 2 bits
Resolution: 4 states/2 bit, 0 offset
Data Range: 0 to 3 Operational Range: same as data range
Type: Status
Supporting information:
PGN 65144

SPN 1475 PCU Trailer, Tag or Push Solenoid Status

Current state of the trailer, tag, or push solenoid used to implement a tire pressure control system in its pneumatic control unit (PCU).

00 - Off
01 - On
10 - Error
11 - Not available

Data Length: 2 bits
Resolution: 4 states/2 bit, 0 offset
Data Range: 0 to 3 Operational Range: same as data range
Type: Status
Supporting information:
PGN 65144

SPN 1480 Source Address of Controlling Device for Retarder Control

The source address of the SAE J1939 device currently controlling the retarder. It is used to expand the torque mode parameter (see SPN 899) in cases where control is in response to an ECU that is not listed in Table SPN899_A. Its value may be the source address of the ECU transmitting the message (which means that no external SAE J1939 message is providing the active command) or the source address of the SAE J1939 ECU that is currently providing the active command in a TSC1 (see PGN 0) or similar message. Note that if this parameter value is the same as the source address of the device transmitting it, the control may be due to a message on a non-SAE J1939 data link such as SAE J1922 or a proprietary link.

Data Length: 1 byte
Resolution: 1 source address/bit, 0 offset
Data Range: 0 to 255 Operational Range: 0 to 253
Type: Status
Supporting information:
PGN 61440

SPN 1481 Source Address of Controlling Device for Brake Control

The source address of the SAE J1939 device currently controlling the brake system. Its value may be the source address of the ECU transmitting the message (which means that no external SAE J1939 message is providing the active command) or the source address of the SAE J1939 ECU that is currently providing the active command in a TSC1 (see PGN 0) or similar message. Note that if this parameter value is the same as the source address of the device transmitting it, the control may be due to a message on a non-SAE J1939 data link such as SAE J1922 or a proprietary link.

Data Length: 1 byte
Resolution: 1 source address/bit, 0 offset
Data Range: 0 to 255 Operational Range: 0 to 253
Type: Status
Supporting information:
PGN 61441

SPN 1482 Source Address of Controlling Device for Transmission Control

The source address of the SAE J1939 device currently controlling the transmission. Its value may be the source address of the ECU transmitting the message (which means that no external SAE J1939 message is providing the active command) or the source address of the SAE J1939 ECU that is currently providing the active command in a TSC1 (see PGN 0) or similar message. Note that if this parameter value is the same as the source address of the device transmitting it, the control may be due to a message on a non-SAE J1939 data link such as SAE J1922 or a proprietary link.

Data Length: 1 byte
Resolution: 1 source address/bit, 0 offset
Data Range: 0 to 255 Operational Range: 0 to 253
Type: Status
Supporting information:
PGN 61442

SPN 1483 Source Address of Controlling Device for Engine Control

The source address of the SAE J1939 device currently controlling the engine. It is used to expand the torque mode parameter (see SPN 899) in cases where control is in response to an ECU that is not listed in Table SPN899_A. Its value may be the source address of the ECU transmitting the message (which means that no external SAE J1939 message is providing the active command) or the source address of the SAE J1939 ECU that is currently providing the active command in a TSC1 (see PGN 0) or similar message. Note that if this parameter value is the same as the source address of the device transmitting it, the control may be due to a message on a non-J1939 data link such as SAE J1922 or a proprietary link.

Data Length: 1 byte
 Resolution: 1 source address/bit, 0 offset
 Data Range: 0 to 255 Operational Range: 0 to 253
 Type: Status
 Supporting information:
 PGN 61444

SPN 1487 Illumination Brightness Percent

Commanded backlight brightness level for all cab displays

Data Length: 1 byte
 Resolution: 0.4 %/bit, 0 offset
 Data Range: 0 to 100 % Operational Range: same as data range
 Type: Status
 Supporting information:
 PGN 53248

SPN 1573 LED Display Data #1

Informs display devices how to display the current vertical position.

0000010 High Coarse LED on
 00000100 High Fine LED on
 00001000 On-grade LED on
 00010000 Low Fine LED on
 00100000 Low Coarse LED on
 All other values Reserved

Data Length: 8 bits
 Resolution: 256 states/8 bit, 0 offset
 Data Range: 0 to 255 Operational Range: same as data range
 Type: Status
 Supporting information:
 PGN 65142

SPN 1574 Laser Strike Vertical Deviation

The calculated distance from the laser strike position to the current land leveling system reference point.

Data Length: 2 bytes
 Resolution: 0.1 mm/bit, -3,200 mm offset
 Data Range: -3,200 to 3,225.5 mm Operational Range: -3200 to +3200 mm, negative values are below grade, positive values are above grade, zero is on grade, 0xFE03 indicates that the sensor can not sense the laser
 Type: Measured

Supporting information:
 PGN 65141

SPN 1575 *Modify Leveling System Set Point*

Used to control and coordinate the set point for the leveling system.

Operating Range: -3200 to +3200 mm, negative values are below current position, positive values are above current position, zero is no change.

Parameter specific parameter:

0xFE01 indicates Stop modifying the set point

0xFE03 indicates Raise the current set point by 5 mm

0xFE11 indicates Lower the current set point by 5 mm

0xFE13 indicates Search for laser or target

0xFE15 indicates go to the Park position

0xFE17 indicates go to the Bench position

Data Length: 2 bytes

Resolution: 0.1 mm/bit, -3,200 mm offset

Data Range: -3,200 to 3,225.5 mm Operational Range: same as data range

Type: Measured

Supporting information:

PGN 65140

SPN 1576 *Mast Position*

Used to monitor the position of the sensor attached to the land leveling mast.

Data Length: 2 bytes

Resolution: 0.1 mm/bit, -3,200 mm offset

Data Range: -3,200 to 3,225.5 mm Operational Range: -3200 to +3200 mm, negative values are below current position, positive values are above current position, zero is no change.

Type: Measured

Supporting information:

PGN 65139

SPN 1577 *Blade Duration and Direction*

Used to indicate the duration and direction that the land leveling system blade moves.

Data Length: 2 bytes

Resolution: 0.1 sec/bit, -3,276.8 sec offset

Data Range: -3276.8 to 3148.7 sec Operational Range: -3276.8 to 3276.8 sec, negative values indicate move the blade up, positive values indicate move the blade down, zero indicates no change

Type: Status

Supporting information:

PGN 65138

SPN 1578 *Blade Control Mode*

Allows the user to select the type of blade control for the land leveling system.

00000000 Manual mode
 00000001 Automatic mode
 00000010 Inactive automatic mode
 All other values Reserved

Data Length: 8 bits
 Resolution: 256 states/8 bit, 0 offset
 Data Range: 0 to 255 Operational Range: same as data range
 Type: Status
 Supporting information:
 PGN 65138

SPN 1579 *Laser Tracer Target Deviation*

The calculated distance for the laser target to the current laser tracer reference point.

Parameter specific parameter: 0xFE03 indicates that the sensor can not sense the laser

Data Length: 2 bytes
 Resolution: 0.1 mm/bit, -3,200 mm offset
 Data Range: -3,200 to 3,225.5 mm Operational Range: -3200 to +3200 mm, negative values are below setpoint, positive values are above setpoint, zero is on grade.
 Type: Measured
 Supporting information:
 PGN 65137

SPN 1580 *Laser Tracer Vertical Distance*

The elevation of the laser tracer sensor in a laser leveling system.

Data Length: 2 bytes
 Resolution: 0.1 mm/bit, 0 offset
 Data Range: 0 to 6,425.5 mm (0 to Operational Range: 0 to 6400 mm
 Type: Measured
 Supporting information:
 PGN 65137

SPN 1581 *Laser Tracer Horizontal Deviation*

The calculated percent deviation between the target distance and the center of the laser tracer.

Data Length: 1 byte
 Resolution: 1 %/bit, 0 offset
 Data Range: 0 to 250 % Operational Range: 0 to 200%, 0 to 99% indicates target is left of center, 101 to 200% indicates target is right of center, 100% indicates target is centered, 0xFF indicates previous pass mode and thus no horizontal deviation
 Type: Measured

Supporting information:
 PGN 65137

SPN 1582 LED Display Data #2

Informs display devices how to display the current position of the laser tracer.

00000001 On-grade "A" LED on
 00000010 On-grade "B" LED on
 00000100 On-grade "C" LED on
 00001000 Up LED on
 00010000 Down LED on
 00100000 Left LED on
 01000000 Right LED on
 All other values Reserved

Data Length: 8 bits
 Resolution: 256 states/8 bit, 0 offset
 Data Range: 0 to 255 Operational Range: same as data range
 Type: Status
 Supporting information:
 PGN 65137

SPN 1583 Laser Tracer Information

Provides the status of the laser tracer to the operator.

00000001 Laser power is on
 00000010 Laser is ready
 00000100 Valid target (1 = yes)
 00001000 Previous pass (1 = yes)
 00010000 Stringline (1 = yes)
 00100000 Curb (1 = yes)
 All other values Reserved

Data Length: 8 bits
 Resolution: 256 states/8 bit, 0 offset
 Data Range: 0 to 255 Operational Range: same as data range
 Type: Status
 Supporting information:
 PGN 65137

SPN 1584 Service Component Identification

Identification of component needing service. See Table SPN911_A.

Data Length: 1 byte
 Resolution: 1 ID/bit, 0 offset
 Data Range: 0 to 250 ID Operational Range: same as data range
 Type: Measured
 Supporting information:
 PGN 56832

SPN 1585 *Powered Vehicle Weight*

Total mass imposed by the tires of the powered vehicle on the road surface. Does not include the trailer.

Data Length: 2 bytes

Resolution: 10 kg/bit, 0 offset

Data Range: 0 to 642,550 kg Operational Range: same as data range

Type: Measured

Supporting information:

PGN 65136

SPN 1586 *Speed of forward vehicle*

Absolute velocity of the preceding vehicle situated within 250 m in the same lane and moving in the same direction.

Data Length: 1 byte

Resolution: 1 km/h per bit, 0 offset

Data Range: 0 to 250 km/h Operational Range: 0xFF = no vehicle detected

Type: Measured

Supporting information:

PGN 65135

SPN 1587 *Distance to forward vehicle*

Distance to the preceding vehicle situated within 250 m in the same lane and moving in the same direction.

Data Length: 1 byte

Resolution: 1 m/bit, 0 offset

Data Range: 0 to 250 m Operational Range: 0xFF = no vehicle detected

Type: Measured

Supporting information:

PGN 65135

SPN 1588 *Adaptive Cruise Control Set Speed*

Value of the desired (chosen) velocity of the adaptive cruise control system.

Data Length: 1 byte

Resolution: 1 km/h per bit, 0 offset

Data Range: 0 to 250 km/h Operational Range: 0 to 120 km/h

Type: Status

Supporting information:

PGN 65135

SPN 1589 Adaptive cruise control set distance mode

Selected distance mode for adaptive cruise control.

000 ACC Distance mode #1 (largest distance)
 001 ACC Distance mode #2
 010 ACC Distance mode #3
 011 ACC Distance mode #4
 100 ACC Distance mode #5 (shortest distance)
 101 Conventional cruise control mode
 110 Error condition
 111 Not available/not valid

Data Length: 3 bits
 Resolution: 8 states/3 bit, 0 offset
 Data Range: 0 to 7 Operational Range: same as data range
 Type: Status
 Supporting information:
 PGN 65135

SPN 1590 Adaptive Cruise Control Mode

This parameter is used to indicate the current state, or mode, of operation by the Adaptive Cruise Control (ACC) device. The states characterize independent system states (e.g., it is not possible to express distance control active and overtake mode simultaneously). ACC must not switch itself off while active because the driver expects it to work. So if an error occurs, the ACC must signal that to the driver so that the driver knows that he has to switch off the ACC.

000 Off (Standby, enabled, ready for activation)
 001 Speed control active
 010 Distance control active
 011 Overtake mode
 100 Hold mode
 101 Finish mode
 110 Disabled or error condition
 111 Not available/not valid

000b - Off—Used to indicate the ACC is enabled in calibration or configuration and there are no faults that would prevent the system from operating.

001b - Speed Control Active—Used to indicate that ACC is on but not currently sending control messages. In other words, there is no target ahead and regular vehicle cruise control is controlling the vehicle speed to the driver's set speed.

010b - Distance Control Active—Used to indicate that ACC is on and actively sending control messages to maintain the appropriate following interval.

011b - Overtake Mode—Used to indicate that ACC is on but temporarily disabled because the driver is manually overriding cruise control by using either the accelerator pedal or the cruise control "accel" switch.

100b - Hold Mode—Used to indicate that the ACC has lost the previous target vehicle and is in HOLD mode. In this mode, the ACC shall limit the speed to the speed held when the target was lost. For example, if the driver activates the typical cruise buttons (Resume/Inc/Dec) the HOLD mode shall be exited and normal cruise functionality resumed. If a new target is detected, the Distance Control Active mode (010b) is again entered, unless existing conditions prohibit this.

101b - Finish Mode—Used to indicate that ACC is on with no target ahead, and ACC is currently sending control messages to return to the driver's set speed. This occurs when the target the ACC system was tracking moves out of the way so ACC returns the vehicle to the driver's set speed.

110b - Disabled or Error Condition—Used to indicate that ACC is in an error state and can not operate.

Data Length: 3 bits
 Resolution: 8 states/3 bit, 0 offset
 Data Range: 0 to 7 Operational Range: same as data range
 Type: Status
 Supporting information:
 PGN 65135

SPN 1591 *Road curvature*

Estimated value of the current road curvature for use by the adaptive cruise control system. Positive values are used for left curves. Curvature is the inverse of the radius and is zero for straight roads.

Data Length: 2 bytes
Resolution: 1/128 1/km per bit, -250 1/km offset
Data Range: -250 to 251.992 1/km Operational Range: same as data range
Type: Status
Supporting information:
PGN 65135

SPN 1592 *Front Axle, Left Wheel Speed*

High resolution measurement of the speed of the left wheel on the front axle.

Data Length: 2 bytes
Resolution: 1/256 km/h per bit, 0 offset
Data Range: 0 to 250.996 km/h Operational Range: same as data range
Type: Measured
Supporting information:
PGN 65134

SPN 1593 *Front axle, right wheel speed*

High resolution measurement of the speed of the right wheel on the front axle.

Data Length: 2 bytes
Resolution: 1/256 km/h per bit, 0 offset
Data Range: 0 to 250.996 km/h Operational Range: same as data range
Type: Measured
Supporting information:
PGN 65134

SPN 1594 *Rear axle, left wheel speed*

High resolution measurement of the speed of the left wheel on the rear axle.

Data Length: 2 bytes
Resolution: 1/256 km/h per bit, 0 offset
Data Range: 0 to 250.996 km/h Operational Range: same as data range
Type: Measured
Supporting information:
PGN 65134

SPN 1595 **Rear axle, right wheel speed**

High resolution measurement of the speed of the right wheel on the rear axle.

Data Length: 2 bytes

Resolution: 1/256 km/h per bit, 0 offset

Data Range: 0 to 250.996 km/h Operational Range: same as data range

Type: Measured

Supporting information:

PGN 65134

SPN 1601 **Local minute offset**

Local offset in minutes from a reference time.

Data Length: 1 byte

Resolution: 1 min/bit, -125 min offset

Data Range: -125 to 125 mins Operational Range: -59 to +59 min

Type: Measured

Supporting information:

PGN 65254

SPN 1602 **Local hour offset**

Local offset in hours from a reference time

Data Length: 1 byte

Resolution: 1 hr/bit, -125 hr offset

Data Range: -125 to 125 hr Operational Range: -23 to +23 h

Type: Measured

Supporting information:

PGN 65254

SPN 1603 **Adjust seconds**

Part of the parameter used to set the time.

Data Length: 1 byte

Resolution: 0.25 s/bit, 0 offset

Data Range: 0 to 62.5 s Operational Range: 0 to 59.75 s

Type: Measured

Supporting information:

PGN 54528

SPN 1604 Adjust minutes

Part of the parameter used to set the time.

Data Length: 1 byte

Resolution: 1 min/bit, 0 offset

Data Range: 0 to 250 mins

Operational Range: 0 to 59 min

Type: Measured

Supporting information:

PGN 54528

SPN 1605 Adjust hours

Part of the parameter used to set the time.

Data Length: 1 byte

Resolution: 1 hr/bit, 0 offset

Data Range: 0 to 250 hr

Operational Range: 0 to 23 h

Type: Measured

Supporting information:

PGN 54528

SPN 1606 Adjust month

Part of a parameter used to set a calendar date.

NOTE - A value of 0 for the month is null. The value 1 identifies January; 2 identifies February; etc.

Data Length: 1 byte

Resolution: 1 month/bit, 0 offset

Data Range: 0 to 250 months

Operational Range: 1 to 12 month

Type: Measured

Supporting information:

PGN 54528

SPN 1607 Adjust day

Part of a parameter used to set a calendar date.

NOTE - A value of 0 for the date is null. The values 1, 2, 3, and 4 are used to identify the first day of the month; 5, 6, 7, and 8 identify the second day of the month; etc.

Data Length: 1 byte

Resolution: 0.25 days/bit, 0 offset

Data Range: 0 to 62.5 days

Operational Range: 0.25 to 31.75 day

Type: Measured

Supporting information:

PGN 54528

SPN 1608 *Adjust year*

Part of a parameter used to set a calendar date.

NOTE - A value of 0 for the year identifies the year 1985; a value of 1 identifies 1986; etc.

Data Length: 1 byte
 Resolution: 1 year/bit, 1985 years offset
 Data Range: 1985 to 2235 years Operational Range: 1985 to 2235 year
 Type: Measured
 Supporting information:
 PGN 54528

SPN 1609 *Adjust local minute offset*

Used to set the local offset in minutes from a reference time.

Data Length: 1 byte
 Resolution: 1 min/bit, -125 min offset
 Data Range: -125 to 125 mins Operational Range: -59 to +59 min
 Type: Measured
 Supporting information:
 PGN 54528

SPN 1610 *Adjust local hour offset*

Used to set the local offset in hours from a reference time

Data Length: 1 byte
 Resolution: 1 hr/bit, -125 hr offset
 Data Range: -125 to 125 hr Operational Range: -24 to +23 h
 Type: Measured
 Supporting information:
 PGN 54528

SPN 1611 *Vehicle motion*

Indicates whether motion of the vehicle is detected or not.

00 Vehicle motion not detected
 01 Vehicle motion detected
 10 - Error
 11 - Not available

Data Length: 2 bits
 Resolution: 4 states/2 bit, 0 offset
 Data Range: 0 to 3 Operational Range: same as data range
 Type: Measured
 Supporting information:
 PGN 65132

SPN 1612 *Driver 1 working state*

State of work of the driver.

000 Rest - sleeping
001 Driver available – short break
010 Work – loading, unloading, working in an office
011 Drive – behind wheel
100-101 Reserved
110 Error
111 Not available

Data Length: 3 bits
Resolution: 8 states/3 bit, 0 offset
Data Range: 0 to 7 Operational Range: same as data range
Type: Status
Supporting information:
PGN 65132

SPN 1613 *Driver 2 working state*

State of work of the driver.

000 Rest - sleeping
001 Driver available – short break
010 Work – loading, unloading, working in an office
011 Drive – behind wheel
100-101 Reserved
110 Error
111 Not available

Data Length: 3 bits
Resolution: 8 states/3 bit, 0 offset
Data Range: 0 to 7 Operational Range: same as data range
Type: Status
Supporting information:
PGN 65132

SPN 1614 *Vehicle Overspeed*

Indicates whether the vehicle is exceeding the legal speed limit set in the tachograph.

00 No overspeed
01 Overspeed
10 Error
11 Not available

Data Length: 2 bits
Resolution: 4 states/2 bit, 0 offset
Data Range: 0 to 3 Operational Range: same as data range
Type: Measured
Supporting information:
PGN 65132

SPN 1615 Driver card, driver 1

Indicates the presence of a driver card

00 - Driver card not present
01 - Driver card present
10 - Error
11 - Not available

Data Length: 2 bits
Resolution: 4 states/2 bit, 0 offset
Data Range: 0 to 3 Operational Range: same as data range
Type: Measured
Supporting information:
PGN 65132

SPN 1616 Driver card, driver 2

Indicates the presence of a driver card

00 - Driver card not present
01 - Driver card present
10 - Error
11 - Not available

Data Length: 2 bits
Resolution: 4 states/2 bit, 0 offset
Data Range: 0 to 3 Operational Range: same as data range
Type: Measured
Supporting information:
PGN 65132

SPN 1617 Driver 1 Time Related States

Indicates if the driver approaches or exceeds working time limits (or other limits).

0000 Normal/No limits reached
0001 Limit #1 – 15 min before 4 ½ h
0010 Limit #2 – 4 ½ h reached
0011 Limit #3 – 15 min before 9 h
0100 Limit #4 – 9 h reached
0101 Limit #5 – 15 min before 16 h (not having 8h rest during the last 24h)
0110 Limit #6 – 16 h reached
0111-1100 Reserved
1101 Other
1110 Error
1111 Not available

Data Length: 4 bits
Resolution: 16 states/4 bit, 0 offset
Data Range: 0 to 15 Operational Range: same as data range
Type: Measured
Supporting information:
PGN 65132

SPN 1618 *Driver 2 Time Related States*

Indicates if the driver approaches or exceeds working time limits (or other limits).

0000 Normal/No limits reached
 0001 Limit #1 – 15 min before 4 ½ h
 0010 Limit #2 – 4 ½ h reached
 0011 Limit #3 – 15 min before 9 h
 0100 Limit #4 – 9 h reached
 0101 Limit #5 – 15 min before 16 h (not having 8h rest during the last 24h)
 0110 Limit #6 – 16 h reached
 0111-1100 Reserved
 1101 Other
 1110 Error
 1111 Not available

Data Length: 4 bits
 Resolution: 16 states/4 bit, 0 offset
 Data Range: 0 to 15 Operational Range: same as data range
 Type: Measured
 Supporting information:
 PGN 65132

SPN 1619 *Direction indicator*

Indicates the direction of the vehicle.

00 - Forward
 01 - Reverse
 10 - Error
 11 - Not available

Data Length: 2 bits
 Resolution: 4 states/2 bit, 0 offset
 Data Range: 0 to 3 Operational Range: same as data range
 Type: Measured
 Supporting information:
 PGN 65132

SPN 1620 *Tachograph performance*

Indicates the tachograph performance; including electronic or mechanical analysis, instrument analysis, speed sensor analysis, mass storage analysis, and printer analysis.

00 - Normal performance
 01 - Performance analysis
 10 - Error
 11 - Not available

Data Length: 2 bits
 Resolution: 4 states/2 bit, 0 offset
 Data Range: 0 to 3 Operational Range: same as data range
 Type: Status
 Supporting information:
 PGN 65132

SPN 1621 Handling information

Indicates that handling information is present. Information could include "no printer paper", "no driver card", etc.

00 - No handling information
 01 - Handling information
 10 - Error
 11 - Not available

Data Length: 2 bits
 Resolution: 4 states/2 bit, 0 offset
 Data Range: 0 to 3 Operational Range: same as data range
 Type: Status
 Supporting information:
 PGN 65132

SPN 1622 System event

Indicates that a tachograph event has occurred. This may include power supply interruption, interruption of the speed sensor, incorrect data on the driver card, driving without a driver card, illegal removal of a driver card, insertion of a driver card during driving, and time adjustment.

00 - No tachograph event
 01 - Tachograph event
 10 - Error
 11 - Not available

Data Length: 2 bits
 Resolution: 4 states/2 bit, 0 offset
 Data Range: 0 to 3 Operational Range: same as data range
 Type: Status
 Supporting information:
 PGN 65132

SPN 1623 Tachograph output shaft speed

Calculated speed of the transmission output shaft.

Data Length: 2 bytes
 Resolution: 0.125 rpm/bit, 0 offset
 Data Range: 0 to 8,031.875 rpm Operational Range: same as data range
 Type: Measured
 Supporting information:
 PGN 65132

SPN 1624 Tachograph vehicle speed

Speed of the vehicle registered by the tachograph.

Data Length: 2 bytes
 Resolution: 1/256 km/h per bit, 0 offset
 Data Range: 0 to 250.996 km/h Operational Range: same as data range
 Type: Measured
 Supporting information:
 PGN 65132

SPN 1625 Driver 1 identification

Used to obtain the driver identity.

Data Length: Variable ("**" delimited)

Resolution: ASCII, 0 offset

Data Range: 0 to 255 per byte Operational Range: same as data range

Type: Measured

Supporting information:

PGN 65131

SPN 1626 Driver 2 identification

Used to obtain the driver identity.

Data Length: Variable ("**" delimited)

Resolution: ASCII, 0 offset

Data Range: 0 to 255 per byte Operational Range: same as data range

Type: Measured

Supporting information:

PGN 65131

SPN 1632 Engine Torque Limit Feature

Torque limit rating described in the current record.

000 Reserved

001 Highest torque rating

010 First torque rating

011 Previous torque rating (rating prior to the current rating)

100 Current torque rating

101-110 Reserved

111 Not available

Data Length: 3 bits

Resolution: 8 states/3 bit, 0 offset

Data Range: 0 to 7 Operational Range: same as data range

Type: Status

Supporting information:

PGN 65168

SPN 1633 Cruise Control Pause Switch

Switch signal which indicates the position of the Cruise Control Pause Switch used on Remote Cruise Control applications. The Cruise Control Pause Switch signal temporarily disables the Cruise Control function.

00 - Off

01 - On

10 - Error Indicator

11 -Take No Action

Data Length: 2 bits

Resolution: 4 states/2 bit, 0 offset

Data Range: 0 to 3 Operational Range: same as data range

Type: Measured

Supporting information:

PGN 65265

SPN 1636 Engine Intake Manifold 1 Air Temperature (High Resolution)

Temperature of pre-combustion air found in intake manifold of engine air supply system. The higher resolution is required for control purposes.

Data Length: 2 bytes
Resolution: 0.03125 deg C/bit, -273 deg C offset
Data Range: -273 to 1735 deg C Operational Range: same as data range
Type: Measured
Supporting information:
PGN 65129

SPN 1637 Engine Coolant Temperature (High Resolution)

Temperature of liquid found in engine cooling system. The higher resolution is required for control purposes.

Data Length: 2 bytes
Resolution: 0.03125 deg C/bit, -273 deg C offset
Data Range: -273 to 1735 deg C Operational Range: same as data range
Type: Measured
Supporting information:
PGN 65129

SPN 1638 Hydraulic Temperature

Temperature of hydraulic fluid.

Data Length: 1 byte
Resolution: 1 deg C/bit, -40 deg C offset
Data Range: -40 to 210 deg C Operational Range: same as data range
Type: Measured
Supporting information:
PGN 65128

SPN 1639 Fan Speed

The speed of the fan associated with engine coolant system.

Data Length: 2 bytes
Resolution: 0.125 rpm/bit, 0 offset
Data Range: 0 to 8,031.875 rpm Operational Range: same as data range
Type: Measured
Supporting information:
PGN 65213

SPN 1653 Vehicle Limiting Speed Governor Enable Switch

Switch signal which enables the Vehicle Limiting Speed Governor (VLSG) such that the vehicle speed may be either increased or decreased when the engine is off idle.

00 - Switch disabled
01 - Switched enabled
10 - Error
11 - Not available

Data Length: 2 bits
Resolution: 4 states/2 bit, 0 offset
Data Range: 0 to 3 Operational Range: same as data range
Type: Measured
Supporting information:
PGN 57344

SPN 1654 Vehicle Limiting Speed Governor Increment Switch

Switch signal which increases the Vehicle Limiting Speed Governor (VLSG).

00 - Switch in the off state
01 - Switch in the on state - increase
10 - Error
11 - Not available

Data Length: 2 bits
Resolution: 4 states/2 bit, 0 offset
Data Range: 0 to 3 Operational Range: same as data range
Type: Measured
Supporting information:
PGN 57344

SPN 1655 Vehicle Limiting Speed Governor Decrement Switch

Switch signal which decreases the Vehicle Limiting Speed Governor (VLSG).

00 - Switch in the off state
01 - Switch in the on state - decrease
10 - Error
11 - Not available

Data Length: 2 bits
Resolution: 4 states/2 bit, 0 offset
Data Range: 0 to 3 Operational Range: same as data range
Type: Measured
Supporting information:
PGN 57344

SPN 1656 Engine Automatic Start Enable Switch

Switch signal which enables the idle management system to be enabled. When this system is enabled with the engine in an idle mode and safe operating conditions existing, then the engine may be started or stopped automatically.

00 - Switch in the off state
01 - Switch in the on state
10 - Error
11 - Not available

Data Length: 2 bits
Resolution: 4 states/2 bit, 0 offset
Data Range: 0 to 3 Operational Range: same as data range
Type: Measured
Supporting information:
PGN 57344

SPN 1665 Engine Turbocharger Oil Level Switch

Switch signal which indicates the presence of oil at the turbocharger

Data Length: 2 bits
Resolution: 4 states/2 bit, 0 offset
Data Range: 0 to 3 Operational Range: same as data range
Type: Measured
Supporting information:
PGN 65245

SPN 1666 Automatic Gear Shifting Enable Switch

Data Length: 2 bits
Resolution: 4 states/2 bit, 0 offset
Data Range: 0 to 3 Operational Range: same as data range
Type: Measured
Supporting information:
PGN 57344

SPN 1667 Retarder Requesting Brake Light

Data Length: 2 bits
Resolution: 4 states/2 bit, 0 offset
Data Range: 0 to 3 Operational Range: same as data range
Type: Status
Supporting information:
PGN 61440

SPN 1675 Engine Starter Mode

There are several phases in a starting action and different reasons why a start cannot take place.

0000 start not requested
 0001 starter active, gear not engaged
 0010 starter active, gear engaged
 0011 start finished; starter not active after having been actively engaged (after 50ms mode goes to 0000)
 0100 starter inhibited due to engine already running
 0101 starter inhibited due to engine not ready for start (preheating)
 0110 starter inhibited due to driveline engaged or other transmission inhibit
 0111 starter inhibited due to active immobilizer
 1000 starter inhibited due to starter over-temp
 1001-1011 Reserved
 1100 starter inhibited - reason unknown
 1101 error (legacy implementation only, use 1110)
 1110 error
 1111 not available

Data Length: 4 bits
 Resolution: 16 states/4 bit, 0 offset
 Data Range: 0 to 15 Operational Range: same as data range
 Type: Status
 Supporting information:
 PGN 61444

SPN 1676 Auxiliary Heater Water Pump Status

Parameter indicating whether the auxiliary heater water pump is running

00 Water Pump is not running
 01 Water Pump is running
 10 Reserved
 11 Not available

Data Length: 2 bits
 Resolution: 4 states/2 bit, 0 offset
 Data Range: 0 to 3 Operational Range: same as data range
 Type: Status
 Supporting information:
 PGN 65133

SPN 1677 Auxiliary Heater Mode

State of the auxiliary heater

0000 Heater not active
 0001 Off due to ADR per European Regulations for Transport of hazardous materials
 0010 Economy mode
 0011 Normal mode
 0100-1101 Not defined
 1110 Error
 1111 Not available

Data Length: 4 bits
 Resolution: 16 states/4 bit, 0 offset
 Data Range: 0 to 15 Operational Range: same as data range
 Type: Status
 Supporting information:
 PGN 65133

SPN 1678 Cab Ventilation

Indicates whether the cab is being ventilated or not.

00 Cab not ventilated
01 Cab is ventilated
10 Reserved
11 Not available

Data Length: 2 bits
Resolution: 4 states/2 bit, 0 offset
Data Range: 0 to 3 Operational Range: same as data range
Type: Status
Supporting information:
PGN 65133

SPN 1679 Engine Heating Zone

Parameter indicating whether the engine zone is being heated.

00 Engine heating zone off
01 Engine heating zone on
10 Reserved
11 Not available

Data Length: 2 bits
Resolution: 4 states/2 bit, 0 offset
Data Range: 0 to 3 Operational Range: same as data range
Type: Status
Supporting information:
PGN 65133

SPN 1680 Cab Heating Zone

Parameter indicating whether the cab zone is being heated.

00 Cab heating zone off
01 Cab heating zone on
10 Reserved
11 Not available

Data Length: 2 bits
Resolution: 4 states/2 bit, 0 offset
Data Range: 0 to 3 Operational Range: same as data range
Type: Status
Supporting information:
PGN 65133

SPN 1681 *Battery Main Switch Hold State*

Parameter indicating whether the battery main switch is held due to an external request or not. The state battery main switch held indicates that the battery main switch is about to switch off.

00 Battery main switch not held
01 Battery main switch held
10 Reserved
11 Don't care/take no action

Data Length: 2 bits
Resolution: 4 states/2 bit, 0 offset
Data Range: 0 to 3 Operational Range: same as data range
Type: Measured
Supporting information:
PGN 65126

SPN 1682 *Battery Main Switch Hold Request*

Request to hold the battery main switch.

00 Release Battery Main Switch
01 Hold Battery Main Switch
10 undefined
11 Don't care/take no action

Data Length: 2 bits
Resolution: 4 states/2 bit, 0 offset
Data Range: 0 to 3 Operational Range: same as data range
Type: Status
Supporting information:
PGN 57344

SPN 1683 *Auxiliary Heater Mode Request*

Request to activate the auxiliary heater.

0000 De-activate auxiliary heater
0001 Off due to ADR per European Regulations for Transport of hazardous materials
0010 Economy mode
0011 Normal mode
0100-1101 Not defined
1110 Reserved
1111 Don't care/take no action

Data Length: 4 bits
Resolution: 16 states/4 bit, 0 offset
Data Range: 0 to 15 Operational Range: same as data range
Type: Status
Supporting information:
PGN 57344

SPN 1684 Auxiliary Heater Coolant Pump Request

Indicates whether to activate the auxiliary heater coolant water pump.

00 Deactivate water pump
01 Activate water pump
10 Reserved
11 Don't care/take no action

Data Length: 2 bits
Resolution: 4 states/2 bit, 0 offset
Data Range: 0 to 3 Operational Range: same as data range
Type: Status
Supporting information:
PGN 57344

SPN 1685 Request Engine Zone Heating

Request to activate engine zone heating.

00 Do not heat engine zone
01 Heat engine zone
10 Reserved
11 Don't care/take no action

Data Length: 2 bits
Resolution: 4 states/2 bit, 0 offset
Data Range: 0 to 3 Operational Range: same as data range
Type: Status
Supporting information:
PGN 57344

SPN 1686 Request Cab Zone Heating

Request to activate cab zone heating.

00 Do not cab engine zone
01 Heat cab zone
10 Reserved
11 Don't care/take no action

Data Length: 2 bits
Resolution: 4 states/2 bit, 0 offset
Data Range: 0 to 3 Operational Range: same as data range
Type: Status
Supporting information:
PGN 57344

SPN 1687 Auxiliary Heater Output Coolant Temperature

Temperature of the auxiliary heater output coolant (I.e. water in a water heater system.)

Data Length: 1 byte

Resolution: 1 deg C/bit, -40 deg C offset

Data Range: -40 to 210 deg C Operational Range: same as data range

Type: Measured

Supporting information:

PGN 65133

SPN 1688 Auxiliary Heater Input Air Temperature

Temperature of the input air in an auxiliary heater system.

Data Length: 1 byte

Resolution: 1 deg C/bit, -40 deg C offset

Data Range: -40 to 210 deg C Operational Range: same as data range

Type: Measured

Supporting information:

PGN 65133

SPN 1689 Auxiliary Heater Output Power Percent

Current auxiliary heater output power, relative to the auxiliary heater maximum output power.

Data Length: 1 byte

Resolution: 0.4 %/bit, 0 offset

Data Range: 0 to 100 % Operational Range: same as data range

Type: Measured

Supporting information:

PGN 65133

SPN 1690 Auxiliary Heater Maximum Output Power

The maximum output power of the auxiliary heater.

Data Length: 2 bytes

Resolution: 2 W/bit, 0 offset

Data Range: 0 to 128,510 W Operational Range: same as data range

Type: Measured

Supporting information:

PGN 65127

SPN 1691 Cab Interior Temperature Command

Parameter used to command a certain cab interior temperature.

Note: See SPN 1662 and SPN 170.

Data Length: 2 bytes
Resolution: 0.03125 deg C/bit, -273 deg C offset
Data Range: -273 to 1735 deg C Operational Range: same as data range
Type: Status
Supporting information:
PGN 57344

SPN 1692 Engine Desired Absolute Intake Manifold Pressure (Turbo Boost Limit)

The desired absolute intake manifold pressure of the engine.

Data Length: 2 bytes
Resolution: 0.1 kPa/bit, 0 offset
Data Range: 0 to 6,425.5 kPa Operational Range: same as data range
Type: Status
Supporting information:
PGN 65194

SPN 1693 Engine Turbocharger Wastegate Valve Position

The position of the turbocharger wastegate valve (not the electronic wastegate control valve).

Data Length: 1 byte
Resolution: 0.4 %/bit, 0 offset
Data Range: 0 to 100 % Operational Range: same as data range
Type: Measured
Supporting information:
PGN 65194

SPN 1694 Engine Gas Mass Flow Sensor Fueling Correction

The amount of fuel the Gas Mass Flow Sensor is sensing should be added or subtracted compared to the maximum amount of fuel the control system allows the sensor to add or subtract.

Data Length: 1 byte
Resolution: 1 %/bit, -125 % offset
Data Range: -125 to 125 % Operational Range: same as data range
Type: Measured
Supporting information:
PGN 65194

SPN 1695 Engine Exhaust Gas Oxygen Sensor Fueling Correction

The amount of fueling change required by the system based on the measured Exhaust Oxygen value compared to the maximum fueling change permitted by the system, expressed as percentages.

Data Length: 1 byte
Resolution: 1 %/bit, -125 % offset
Data Range: -125 to 125 % Operational Range: same as data range
Type: Status
Supporting information:
PGN 65193

SPN 1696 (R) Engine Exhaust Gas Oxygen Sensor Closed Loop Operation

Indicates whether the engine is using the Exhaust Gas Oxygen sensor to control the air/fuel ratio.

00 Engine not using the Exhaust Gas Oxygen sensor (open loop)
01 Engine using the Exhaust Gas Oxygen sensor for a closed loop operation
10 Reserved
11 Don't Care/take no action

See also SPN 4240 for an implementation with more states.

Data Length: 2 bits
Resolution: 4 states/2 bit, 0 offset
Data Range: 0 to 3 Operational Range: same as data range
Type: Status
Supporting information:
PGN 65193

SPN 1697 CTI Wheel End Electrical Fault

Indicates the status of electrical fault on CTI wheel interface.

00 Ok (No Fault)
01 Not Defined
10 Error
11 Not Supported

Data Length: 2 bits
Resolution: 4 states/2 bit, 0 offset
Data Range: 0 to 3 Operational Range: same as data range
Type: Measured
Supporting information:
PGN 65268

SPN 1698 CTI Tire Status

Indicates the status of the tire.

00 Ok (no fault)
01 Tire leak detected
10 Error
11 Not Supported

Data Length: 2 bits
Resolution: 4 states/2 bit, 0 offset
Data Range: 0 to 3 Operational Range: same as data range
Type: Measured
Supporting information:
PGN 65268

SPN 1699 CTI Wheel Sensor Status

Indicates whether the wheel is being monitored by the CTI controller.

00 Off / isolated from CTI Pressure Controller
01 On (tire is polled)
10 Not Defined
11 Not Supported

Data Length: 2 bits
Resolution: 4 states/2 bit, 0 offset
Data Range: 0 to 3 Operational Range: same as data range
Type: Measured
Supporting information:
PGN 65268

SPN 1700 Lane Departure Imminent, Left Side

Indicates departure imminent on left side of lane.

00 Not imminent
01 Imminent
10 Reserved
11 Not used

Data Length: 2 bits
Resolution: 4 states/2 bit, 0 offset
Data Range: 0 to 3 Operational Range: same as data range
Type: Status
Supporting information:
PGN 61447

SPN 1701 Lane Departure Imminent, Right Side

Indicates departure imminent on right side of lane.

00 Not imminent
01 Imminent
10 Reserved
11 Not Used

Data Length: 2 bits
Resolution: 4 states/2 bit, 0 offset
Data Range: 0 to 3 Operational Range: same as data range
Type: Status
Supporting information:
PGN 61447

SPN 1702 Lane Departure Indication Enable Status

Indicates whether lane departure indication is active.

00 Lane Departure indication disabled
01 Lane Departure Indication enabled
10 Reserved
11 Not Used

Data Length: 2 bits
Resolution: 4 states/2 bit, 0 offset
Data Range: 0 to 3 Operational Range: same as data range
Type: Status
Supporting information:
PGN 65115

SPN 1710 Lane Tracking Status Left Side

Indicates whether the left side is tracking lane.

00 Not Tracking Left side
01 Tracking Left side
10 Reserved
11 Don't care/Take no action

Data Length: 2 bits
Resolution: 4 states/2 bit, 0 offset
Data Range: 0 to 3 Operational Range: same as data range
Type: Status
Supporting information:
PGN 65115

SPN 1711 Lane Tracking Status Right Side

Indicates whether right side is tracking lane.

00 Not Tracking Right side
 01 Tracking Right side
 10 Reserved
 11 Don't Care/take no action

Data Length: 2 bits
 Resolution: 4 states/2 bit, 0 offset
 Data Range: 0 to 3 Operational Range: same as data range
 Type: Status
 Supporting information:
 PGN 65115

SPN 1712 Engine Extended Range Requested Speed Control Range Upper Limit (Engine configuration)

The maximum engine speed regardless of load that the engine will allow when operating in a speed control/limit mode, excluding any maximum momentary engine override speed, if supported.

When the limit is higher than 2500 RPM the 'Requested Speed Control Range Upper Limit (Engine Configuration)' parameter (see SPN 536) will be transmitted with a value of 2500 RPM.

Data Length: 2 bytes
 Resolution: 0.125 rpm/bit, 0 offset
 Data Range: 0 to 8,031.875 rpm Operational Range: same as data range
 Type: Measured
 Supporting information:
 PGN 65251

SPN 1713 Hydraulic Oil Filter Restriction Switch

This switch indicates whether hydraulic oil filter is clogged. This is not the transmission oil filter restriction switch, which is SPN 3359.

00 No restriction
 01 Restriction exists on oil filter
 10 Error
 11 Not Available

Data Length: 2 bits
 Resolution: 4 states/2 bit, 0 offset
 Data Range: 0 to 3 Operational Range: same as data range
 Type: Measured
 Supporting information:
 PGN 65128

SPN 1714 Operator Seat Direction Switch

Senses whether the operator seat is in the forward driving position

00 Operator seat not facing forward
 01 Operator seat is facing forward
 10 Error
 11 Not Available

Data Length: 2 bits
 Resolution: 4 states/2 bit, 0 offset
 Data Range: 0 to 3 Operational Range: same as data range
 Type: Measured
 Supporting information:
 PGN 57344

SPN 1715 Drivers Demand Retarder - Percent Torque

The Drivers demand retarder – percent torque is the maximum torque selected by the driver when one or more modes are selected by the driver, such as hand lever, switch, constant torque, constant velocity, etc.

Data Length: 1 byte
 Resolution: 1 %/bit, -125 % offset
 Data Range: -125 to 125 % Operational Range: -125% to 0%
 Type: Status
 Supporting information:
 PGN 61440

SPN 1716 Retarder Selection, non-engine

The “Retarder Selection, non-engine” is the position of the driver’s selector for retarders that are not part of the engine system, expressed as percent and determined by the ratio of current position to the maximum possible position. The physical device may be a lever, rotary dial, combination of switches, or other device that the driver can use to select the type or amount of retardation needed.

Data Length: 1 byte
 Resolution: 0.4 %/bit, 0 offset
 Data Range: 0 to 100 % Operational Range: same as data range
 Type: Measured
 Supporting information:
 PGN 61440

SPN 1717 Actual Maximum Available Retarder - Percent Torque

This is the maximum amount of torque that the retarder can immediately deliver. It is the same as the maximum torque shown in the Retarder’s Configuration message, but allows for a much faster rate of change than could be communicated by reissuing the configuration message.

Application Note: The purpose for this parameter is to allow a “Master” retarder controller to more accurately allocate the vehicle’s retarder requirements among multiple retarders. Its value should be the same as the value in the Configuration message at the time that message is assembled for broadcast, but may vary between those broadcasts.

Data Length: 1 byte
 Resolution: 1 %/bit, -125 % offset
 Data Range: -125 to 125 % Operational Range: -125 % to 0
 Type: Measured
 Supporting information:
 PGN 61440

SPN 1718 *Damper Stiffness Request Front Axle*

Demand value for the shock absorber control at the front axle.

Data Length: 1 byte

Resolution: 0.4 %/bit, 0 offset

Data Range: 0 to 100 % Operational Range: same as data range

Type: Status

Supporting information:

PGN 53760

SPN 1719 *Damper Stiffness Request Rear Axle*

Demand value for the shock absorber control at the rear axle.

Data Length: 1 byte

Resolution: 0.4 %/bit, 0 offset

Data Range: 0 to 100 % Operational Range: same as data range

Type: Status

Supporting information:

PGN 53760

SPN 1720 *Damper Stiffness Request Lift / Tag Axle*

Demand value for the shock absorber control at the lift or tag axle

Data Length: 1 byte

Resolution: 0.4 %/bit, 0 offset

Data Range: 0 to 100 % Operational Range: same as data range

Type: Status

Supporting information:

PGN 53760

SPN 1721 *Relative Level Front Axle Left*

Information of the height at the left side of the front axle referred to normal level 1. For explanations of normal level 1 see SPN 1734 - Nominal Level Front Axle.

Data Length: 2 bytes

Resolution: 0.1 mm/bit, -3,200 mm offset

Data Range: -3,200 to 3,225.5 mm Operational Range: same as data range

Type: Measured

Supporting information:

PGN 65113

SPN 1722 *Relative Level Front Axle Right*

Information of the height at the right side of the front axle referred to normal level 1. For explanations of normal level 1 see SPN 1734 - Nominal Level Front Axle.

Data Length: 2 bytes
Resolution: 0.1 mm/bit, -3,200 mm offset
Data Range: -3,200 to 3,225.5 mm Operational Range: same as data range
Type: Measured
Supporting information:
PGN 65113

SPN 1723 *Relative Level Rear Axle Right*

Information of the height at the left side of the rear axle referred to normal level 1. For explanations of normal level 1 see parameter SPN 1734 - Nominal Level Front Axle.

Data Length: 2 bytes
Resolution: 0.1 mm/bit, -3,200 mm offset
Data Range: -3,200 to 3,225.5 mm Operational Range: same as data range
Type: Measured
Supporting information:
PGN 65113

SPN 1724 *Relative Level Rear Axle Left*

Information of the height at the left side of the rear axle referred to normal level 1. For explanations of normal level 1 see parameter SPN 1734 - Nominal Level Front Axle.

Data Length: 2 bytes
Resolution: 0.1 mm/bit, -3,200 mm offset
Data Range: -3,200 to 3,225.5 mm Operational Range: same as data range
Type: Measured
Supporting information:
PGN 65113

SPN 1725 *Bellow Pressure Front Axle Left*

Information of the pressure of the air suspension bellow at the left side of the front axle

Data Length: 2 bytes
Resolution: 0.1 kPa/bit, 0 offset
Data Range: 0 to 6,425.5 kPa Operational Range: same as data range
Type: Measured
Supporting information:
PGN 65112

SPN 1726 Bellow Pressure Front Axle Right

Information of the pressure of the air suspension bellow at the right side of the front axle

Data Length: 2 bytes

Resolution: 0.1 kPa/bit, 0 offset

Data Range: 0 to 6,425.5 kPa Operational Range: same as data range

Type: Measured

Supporting information:

PGN 65112

SPN 1727 Bellow Pressure Rear Axle Left

Information of the pressure of the air suspension bellow at the left side of the rear axle

Data Length: 2 bytes

Resolution: 0.1 kPa/bit, 0 offset

Data Range: 0 to 6,425.5 kPa Operational Range: same as data range

Type: Measured

Supporting information:

PGN 65112

SPN 1728 Bellow Pressure Rear Axle Right

Information of the pressure of the air suspension bellow at the right side of the rear axle

Data Length: 2 bytes

Resolution: 0.1 kPa/bit, 0 offset

Data Range: 0 to 6,425.5 kPa Operational Range: same as data range

Type: Measured

Supporting information:

PGN 65112

SPN 1729 Damper Stiffness Front Axle

Damper stiffness information of the shock absorber control at the front axle

Data Length: 1 byte

Resolution: 0.4 %/bit, 0 offset

Data Range: 0 to 100 % Operational Range: same as data range

Type: Status

Supporting information:

PGN 65111

SPN 1730 *Damper Stiffness Rear Axle*

Damper stiffness information of the shock absorber control at the rear axle

Data Length: 1 byte

Resolution: 0.4 %/bit, 0 offset

Data Range: 0 to 100 % Operational Range: same as data range

Type: Status

Supporting information:

PGN 65111

SPN 1731 *Damper Stiffness Lift / Tag Axle*

Damper stiffness information of the shock absorber control at the lift of tag axle

Data Length: 1 byte

Resolution: 0.4 %/bit, 0 offset

Data Range: 0 to 100 % Operational Range: same as data range

Type: Status

Supporting information:

PGN 65111

SPN 1732 *Level Preset Front Axle Left*

Set value for nominal level 'preset level' at the left side of the front axle. This value is referred to 'Normal level 1'. For explanations of normal level 1 see parameter SPN 1734 - Nominal Level Front Axle.

Data Length: 2 bytes

Resolution: 0.1 mm/bit, -3,200 mm offset

Data Range: -3,200 to 3,225.5 mm Operational Range: same as data range

Type: Status

Supporting information:

PGN 53504

SPN 1733 Nominal Level Rear Axle

Signal which indicates the nominal (desired) height of the rear axle to be controlled by the suspension system.

For further explanations see SPN 1734 - Nominal Level Front Axle.

0000 Level not specified,(i.e. the nominal level is none of the specified levels, no error condition)
0001 "Normal Level 1,(i.e. the level prescribed for normal driving, given by design)
0010 "Normal Level 2,(i.e. a level permitted for driving, for example to lower the vehicle in case of high speed)
0011 "Normal Level 3,(i.e. a level permitted for driving, for example to lift the vehicle in case of offroad)
0100 "Preset Level,(i.e. a level to be defined externally via CAN)
0101 "Customer Level,(i.e. a level to be defined by customer via parameter setting)
0110 "Upper Level,(i.e. the highest level to be controlled)
0111 "Lower Level,(i.e. the lowest level to be controlled)
1000-1101 Not defined
1110 Error
1111 Not available

Data Length: 4 bits
Resolution: 16 states/4 bit, 0 offset
Data Range: 0 to 15 Operational Range: same as data range
Type: Status
Supporting information:
PGN 65114

SPN 1734 Nominal Level Front Axle

Signal which indicates the nominal (desired) height of the front axle to be controlled by the suspension system.

These heights are discrete levels. They are the upper level, lower level, normal level 1, normal level 2, normal level 3, customer level, and preset level. Refer to Figure SPN1734_A.

- Upper Level is the highest mechanically available height of the vehicle.
- Lower Level is the lowest mechanically available height of the vehicle.

Normal Levels 1, 2 and 3 are heights normally used during driving.
· Normal Level 1 is most often used and is given by design.
· Normal Level 2 may be chosen, for example, to be lower than Normal Level 1 for the purpose of reducing fuel consumption while driving on highways.
· Normal Level 3 may be chosen above Normal Level 1 for driving off road.

The preset level has to be set by means of ASC 6 (PGN: 53504).

0000 Level not specified,(i.e. the nominal level is none of the specified levels, no error condition)
0001 "Normal Level 1,(i.e. the level prescribed for normal driving, given by design)
0010 "Normal Level 2,(i.e. a level permitted for driving, for example to lower the vehicle in case of high speed)
0011 "Normal Level 3,(i.e. a level permitted for driving, for example to lift the vehicle in case of offroad)
0100 "Preset Level,(i.e. a level to be defined externally via CAN)
0101 "Customer Level,(i.e. a level to be defined by customer via parameter setting)
0110 "Upper Level,(i.e. the highest level to be controlled)
0111 "Lower Level,(i.e. the lowest level to be controlled)
1000-1101 Not defined
1110 Error
1111 Not available

Data Length: 4 bits
Resolution: 16 states/4 bit, 0 offset
Data Range: 0 to 15 Operational Range: same as data range
Type: Status
Supporting information: See Appendix D - SPN 1734
PGN 65114

SPN 1735 Level Preset Rear Axle Right

Set value for nominal level 'preset level' at the right side of the rear axle. This value is referred to 'Normal level 1'. For explanations of normal level 1 see SPN 1734 - Nominal Level Front Axle.

Data Length: 2 bytes
Resolution: 0.1 mm/bit, -3,200 mm offset
Data Range: -3,200 to 3,225.5 mm Operational Range: same as data range
Type: Status
Supporting information:
PGN 53504

SPN 1736 Above Nominal Level Rear Axle

Signal which indicates whether the actual height of the rear axle is above the nominal (desired) level of the rear axle. For explanations of nominal level see parameter SPN 1734 - Nominal Level Front Axle.

00 Not above
01 Above
10 Error
11 Not available

Data Length: 2 bits
Resolution: 4 states/2 bit, 0 offset
Data Range: 0 to 3 Operational Range: same as data range
Type: Measured
Supporting information:
PGN 65114

SPN 1737 Above Nominal Level Front Axle

Signal which indicates whether the actual height of the front axle is above the nominal (desired) level of the front axle. For explanations of nominal level see SPN 1734 - Nominal Level Front Axle.

00 Not above
01 Above
10 Error
11 Not available

Data Length: 2 bits
Resolution: 4 states/2 bit, 0 offset
Data Range: 0 to 3 Operational Range: same as data range
Type: Measured
Supporting information:
PGN 65114

SPN 1738 Below Nominal Level Front Axle

Signal which indicates whether the actual height of the front axle is below the nominal (desired) level for the front axle. For explanations of nominal level see parameter SPN 1734 - Nominal Level Front Axle.

00 Not below
01 Below
10 Error
11 Not available

Data Length: 2 bits
Resolution: 4 states/2 bit, 0 offset
Data Range: 0 to 3 Operational Range: same as data range
Type: Measured
Supporting information:
PGN 65114

SPN 1739 Lifting Control Mode Front Axle

Signal which indicates the actual lifting level change at the front axle

00 Lifting not active
01 Lifting active
10 Error
11 Not available

Data Length: 2 bits
Resolution: 4 states/2 bit, 0 offset
Data Range: 0 to 3 Operational Range: same as data range
Type: Status
Supporting information:
PGN 65114

SPN 1740 Lowering Control Mode Front Axle

Signal which indicates the actual lowering level change at the front axle

00 Lowering not active
01 Lowering active
10 Error
11 Not available

Data Length: 2 bits
Resolution: 4 states/2 bit, 0 offset
Data Range: 0 to 3 Operational Range: same as data range
Type: Status
Supporting information:
PGN 65114

SPN 1741 Level Control Mode

Signal which indicates the actual control mode of the air suspension system

0000 Normal operation; i.e. the system performs a "pure" control of the vehicle height
0001 Traction help (load transfer); i.e. the driven axle is loaded to a maximum value given by legislation or design
0010 Load fixing; i.e. the driven axlen is loaded to a value defined by the driver
0011 Pressure ratio 1; i.e. the ratio between the pressures at the driven axle and at the third axle is controlled, so that the ratio equals a fixed value 1
0100 Pressure ratio 2; i.e. the ratio between the pressures at the driven axle and at the third axle is controlled, so that the ratio equals a fixed value 2
0101 Optimum traction 1; i.e. the pressure at the driven axle is controlled at a fixed value 1
0110 Optimum traction 2; i.e. the pressure at the driven axle is controlled at a fixed value 2
0111 Traction help - load reduce; (i.e. the driven axle load is reduced to normal load condition)
1000 Exhausting bellow function; i.e. the bellows are exhausted totally
1001 Air suspension control prohibited (i.e. hold current pressures in all suspension devices.)
1010-1101 Not defined
1110 Error
1111 Not available

Data Length: 4 bits
Resolution: 16 states/4 bit, 0 offset
Data Range: 0 to 15 Operational Range: same as data range
Type: Status
Supporting information:
PGN 65114

SPN 1742 Kneeling Information

Signal which indicates the actual level change in case of kneeling function

0000 Not active,(i.e. the kneeling function is not active")
0001 Lowering active,(i.e. the vehicle is lowered due to a kneeling request)
0010 Kneeling level reached,(i.e. the vehicle is at the fixed kneeling level)
0011 Lifting active,(i.e. the vehicle is lifted due to a recover request)
0100 Kneeling aborted,(i.e. in case of manual actuation the request was dropped before the kneeling level was reached)
0101-1101 Not defined
1110 Error
1111 Not available

Data Length: 4 bits
Resolution: 16 states/4 bit, 0 offset
Data Range: 0 to 15 Operational Range: same as data range
Type: Status
Supporting information:
PGN 65114

SPN 1743 Lift Axle 1 Position

Signal which indicates the position / load condition of lift axle / tag axle #1. Numbering of lift/tag axles starts at front axle.

00 Lift axle position down / tag axle laden
01 Lift axle position up / tag axle unladen
10 Error
11 Not available

Data Length: 2 bits
Resolution: 4 states/2 bit, 0 offset
Data Range: 0 to 3 Operational Range: same as data range
Type: Measured
Supporting information:
PGN 65114

SPN 1744 Door Release

Signal which indicates that the doors may be opened. [Please note: doors instead of door!]
In case a kneeling request is active the ASC indicates during lowering the vehicle „doors shall not be opened“ as a security information until the kneeling level is reached. Then "doors may be opened" is sent.

00 Doors may not be opened
01 Doors may be opened
10 Error
11 Not available

Data Length: 2 bits
Resolution: 4 states/2 bit, 0 offset
Data Range: 0 to 3 Operational Range: same as data range
Type: Status
Supporting information:
PGN 65114

SPN 1745 Vehicle Motion Inhibit

Signal which indicates whether vehicle motion is inhibited.

00 Vehicle may be moved
01 Vehicle motion is inhibited
10 Error
11 Not available

Data Length: 2 bits
Resolution: 4 states/2 bit, 0 offset
Data Range: 0 to 3 Operational Range: same as data range
Type: Status
Supporting information:
PGN 65114

SPN 1746 Security Device

The signal which indicates the status of the security device. An example of a security device is a curbstone feeler installed beneath the doors of a bus. If the security device becomes active during kneeling the kneeling process (lowering) is stopped and the vehicle lifts back to the starting level.

00 Not active
01 Active
10 Error
11 Not available

Data Length: 2 bits
Resolution: 4 states/2 bit, 0 offset
Data Range: 0 to 3 Operational Range: same as data range
Type: Status
Supporting information:
PGN 65114

SPN 1747 Kneeling Control Mode Request

Command signal to select the kneeling functionality

00 Automatically actuated
01 Manually actuated
10 Reserved
11 Don't care/take no action

Data Length: 2 bits
Resolution: 4 states/2 bit, 0 offset
Data Range: 0 to 3 Operational Range: same as data range
Type: Status
Supporting information:
PGN 53760

SPN 1748 Kneeling Request Right Side

Command signal to activate the kneeling functionality on the right side of the vehicle

00 No kneeling request
01 Kneeling request
10 Reserved
11 Don't care/take no action

Data Length: 2 bits
Resolution: 4 states/2 bit, 0 offset
Data Range: 0 to 3 Operational Range: same as data range
Type: Status
Supporting information:
PGN 53760

SPN 1749 *Kneeling Request Left Side*

Command signal to activate the kneeling functionality on the left side of the vehicle

00 No kneeling request
 01 Kneeling request
 10 Reserved
 11 Don't care/take no action

Data Length: 2 bits

Resolution: 4 states/2 bit, 0 offset

Data Range: 0 to 3

Operational Range: same as data range

Type: Status

Supporting information:

PGN 53760

SPN 1750 *Nominal Level Request Rear Axle*

Command signal to activate a level of the rear axle programmed and/or memorized in the ECU. For explanations of nominal level see SPN 1734 - Nominal Level Front Axle.

0000 No level request
 0001 Normal Level 1,(i.e. the level prescribed for normal driving, given by design)
 0010 Normal Level 2,(i.e. a level permitted for driving, for example to lower the vehicle in case of high speed)
 0011 Normal Level 3,(i.e. a level permitted for driving, for example to lift the vehicle in case of offroad)
 0100 Preset Level,(i.e. a level to be defined externally via CAN)
 0101 Customer Level,(i.e. a level to be defined by customer via parameter setting)
 0110 Upper Level,(i.e. the highest level to be controlled)
 0111 Lower Level,(i.e. the lowest level to be controlled)
 1000 Stop level change,(i.e. the level change in process shall be stopped immediately)
 1001-1101 Not defined
 1110 Reserved
 1111 Don't care/take no action

Data Length: 4 bits

Resolution: 16 states/4 bit, 0 offset

Data Range: 0 to 15

Operational Range: same as data range

Type: Status

Supporting information:

PGN 53760

SPN 1751 Nominal Level Request Front Axle

Command signal to activate a level of the front axle programmed and/or memorized in the ECU For explanations of nominal level see SPN 1734 - Nominal Level Front Axle.

0000 No level request
0001 Normal Level 1,(i.e. the level prescribed for normal driving, given by design)
0010 Normal Level 2,(i.e. a level permitted for driving, for example to lower the vehicle in case of high speed)
0011 Normal Level 3,(i.e. a level permitted for driving, for example to lift the vehicle in case of offroad)
0100 Preset Level,(i.e. a level to be defined externally via CAN)
0101 Customer Level,(i.e. a level to be defined by customer via parameter setting)
0110 Upper Level,(i.e. the highest level to be controlled)
0111 Lower Level,(i.e. the lowest level to be controlled)
1000 Stop level change,(i.e. the level change in process shall be stopped immediately)
1001-1101 Not defined
1110 Reserved
1111 Don't care/take no action

Data Length: 4 bits
Resolution: 16 states/4 bit, 0 offset
Data Range: 0 to 15 Operational Range: same as data range
Type: Status
Supporting information:
PGN 53760

SPN 1752 Lift Axle 1 Position Command

Signal to command the position/load condition of lift/tag axle #1. Numbering of lift/tag axles starts at front axle.

00 Lift axle position down / tag axle laden
01 Lift axle position up / tag axle unladen
10 Reserved
11 Don't care/take no action

Data Length: 2 bits
Resolution: 4 states/2 bit, 0 offset
Data Range: 0 to 3 Operational Range: same as data range
Type: Status
Supporting information:
PGN 53760

SPN 1753 Level Control Mode Request

Command signal to activate a level control mode

0000 Normal operation; i.e. the system performs a ""pure"" control of the vehicle height
 0001 Traction help (load transfer); i.e. the driven axle is loaded to a maximum value given by legislation or design
 0010 Load fixing; i.e. the driven axle is loaded to a value defined by the driver
 0011 Pressure ratio 1; i.e. the ratio between the pressures at the driven axle and at the third axle is controlled, so that the ratio equals a fixed value 1
 0100 Pressure ratio 2; i.e. the ratio between the pressures at the driven axle and at the third axle is controlled, so that the ratio equals a fixed value 2
 0101 Optimum traction 1; i.e. the pressure at the driven axle is controlled at a fixed value 1
 0110 Optimum traction 2; i.e. the pressure at the driven axle is controlled at a fixed value 2
 0111 Traction help - load reduce; (i.e. reduce axle load of driven axle to normal load condition)
 1000 Exhaust bellows
 1001 -1101 Not defined
 1110 Reserved
 1111 Don't care/take no action

Data Length: 4 bits
 Resolution: 16 states/4 bit, 0 offset
 Data Range: 0 to 15 Operational Range: same as data range
 Type: Status
 Supporting information:
 PGN 53760

SPN 1754 Below Nominal Level Rear Axle

Signal which indicates whether the actual height of the rear axle is below the nominal (desired) level for the rear axle. For explanations of nominal level see SPN 1734 - Nominal Level Front Axle.

00 Not below
 01 Below
 10 Error
 11 Not available

Data Length: 2 bits
 Resolution: 4 states/2 bit, 0 offset
 Data Range: 0 to 3 Operational Range: same as data range
 Type: Status
 Supporting information:
 PGN 65114

SPN 1755 Lowering Control Mode Rear Axle

Signal which indicates the actual lowering level change at the rear axle

00 Lowering not active
 01 Lowering active
 10 Error
 11 Not available

Data Length: 2 bits
 Resolution: 4 states/2 bit, 0 offset
 Data Range: 0 to 3 Operational Range: same as data range
 Type: Status
 Supporting information:
 PGN 65114

SPN 1756 *Lifting Control Mode Rear Axle*

Signal which indicates the actual lifting level change at the rear axle

00 Lifting not active
 01 Lifting active
 10 Error
 11 Not available

Data Length: 2 bits
 Resolution: 4 states/2 bit, 0 offset
 Data Range: 0 to 3 Operational Range: same as data range
 Type: Status
 Supporting information:
 PGN 65114

SPN 1757 *Level Preset Front Axle Right*

Set value for nominal level 'preset level' at the right side of the front axle. This value is referred to 'Normal level 1'. For explanations of normal level 1 see SPN 1734 - Nominal Level Front Axle.

Data Length: 2 bytes
 Resolution: 0.1 mm/bit, -3,200 mm offset
 Data Range: -3,200 to 3,225.5 mm Operational Range: same as data range
 Type: Status
 Supporting information:
 PGN 53504

SPN 1758 *Level Preset Rear Axle Left*

Set value for nominal level 'preset level' at the left side of the rear axle. This value is referred to 'Normal level 1'. For explanations of normal level 1 see SPN 1734 - Nominal Level Front Axle.

Data Length: 2 bytes
 Resolution: 0.1 mm/bit, -3,200 mm offset
 Data Range: -3,200 to 3,225.5 mm Operational Range: same as data range
 Type: Status
 Supporting information:
 PGN 53504

SPN 1759 *Blade Height Set Point - High Resolution*

High resolution for the laser guided blade set point. The high resolution required for more accurate control and 'accurate' unit conversions.

Negative values are below grade, positive values are above grade, zero is on grade.

Data Length: 4 bytes
 Resolution: 100 mm/bit, -209.7152 m offset
 Data Range: -209.7152 to 211.3929215 m Operational Range: -209.7152m to 209.7152m
 Type: Measured
 Supporting information:
 PGN 65140

SPN 1760 Gross Combination Vehicle Weight

The total weight of the truck and all attached trailers.

Data Length: 2 bytes

Resolution: 10 kg/bit, 0 offset

Data Range: 0 to 642,550 kg Operational Range: same as data range

Type: Measured

Supporting information:

PGN 65136

SPN 1761 Catalyst Tank Level

A special catalyst uses chemical substance to reach legal requirement for NOX emissions. This parameter indicates the level within that catalyst tank.

0 % = Empty

100% = Full

Data Length: 1 byte

Resolution: 0.4 %/bit, 0 offset

Data Range: 0 to 100 % Operational Range: same as data range

Type: Measured

Supporting information:

PGN 65110

SPN 1762 Hydraulic Pressure

Hydraulic pressure measured at the output of the hydraulic pump.

Data Length: 2 bytes

Resolution: 2 kPa/bit, 0 offset

Data Range: 0 to 128,510 kPa Operational Range: same as data range

Type: Measured

Supporting information:

PGN 61448

SPN 1763 Engine Hydraulic Pressure Governor Mode Indicator

Mode for governor operation is hydraulic pressure control.

00 Disabled

01 Enabled

10 Error Indicator

11 Not Available

Data Length: 2 bits

Resolution: 4 states/2 bit, 0 offset

Data Range: 0 to 3 Operational Range: same as data range

Type: Status

Supporting information:

PGN 61448

SPN 1764 Engine Hydraulic Pressure Governor Switch

Switch that sets the mode of hydraulic governor

00 Pressure Mode Inactive
01 Pressure Mode Active
10 Error Indicator
11 Not Available

Data Length: 2 bits
Resolution: 4 states/2 bit, 0 offset
Data Range: 0 to 3 Operational Range: same as data range
Type: Measured
Supporting information:
PGN 61448

SPN 1765 Engine Requested Fuel Valve 1 Position

The requested position of a gaseous fuel valve 1 that is metering the fuel flow to the engine.

Data Length: 1 byte
Resolution: 0.4 %/bit, 0 offset
Data Range: 0 to 100 % Operational Range: same as data range
Type: Status
Supporting information:
PGN 65153

SPN 1766 Engine Requested Fuel Valve 2 Position

The requested position of a gaseous fuel valve 2 that is metering the fuel flow to the engine, as requested by the Engine Control Unit.

Data Length: 1 byte
Resolution: 0.4 %/bit, 0 offset
Data Range: 0 to 100 % Operational Range: same as data range
Type: Status
Supporting information:
PGN 65153

SPN 1767 Specific Heat Ratio

The specific heat ratio of the fuel.

Data Length: 2 bytes
Resolution: 0.001/bit, 0 offset
Data Range: 0 to 64.255 Operational Range: 0 to 2.0000
Type: Status
Supporting information:
PGN 65109

SPN 1768 Engine Low Limit Threshold for Maximum RPM from Engine

Minimum allowable value for maximum continuous RPM from engine

Data Length: 1 byte

Resolution: 32 rpm/bit, 0 offset

Data Range: 0 to 8,000 rpm Operational Range: same as data range

Type: Status

Supporting information:

PGN 65108

SPN 1769 Engine High Limit Threshold for Minimum Continuous Engine RPM

Maximum allowable value for minimum continuous RPM from engine

Data Length: 1 byte

Resolution: 32 rpm/bit, 0 offset

Data Range: 0 to 8,000 rpm Operational Range: same as data range

Type: Status

Supporting information:

PGN 65108

SPN 1770 Engine Low Limit Threshold for Maximum Torque from Engine

Minimum allowable value for maximum continuous torque from engine

Data Length: 1 byte

Resolution: 1 %/bit, -125 % offset

Data Range: -125 to 125 % Operational Range: same as data range

Type: Status

Supporting information:

PGN 65108

SPN 1771 Engine High Limit Threshold for Minimum Continuous Torque from Engine

Maximum allowable value for minimum continuous torque from engine

Data Length: 1 byte

Resolution: 1 %/bit, -125 % offset

Data Range: -125 to 125 % Operational Range: same as data range

Type: Status

Supporting information:

PGN 65108

SPN 1772 Engine Maximum Continuous RPM

Applied limit for maximum continuous engine RPM

Data Length: 1 byte

Resolution: 32 rpm/bit, 0 offset

Data Range: 0 to 8,000 rpm Operational Range: same as data range

Type: Status

Supporting information:

PGN 65108

SPN 1773 Engine Minimum Continuous RPM

Applied limit for minimum continuous engine RPM

Data Length: 1 byte

Resolution: 32 rpm/bit, 0 offset

Data Range: 0 to 8,000 rpm Operational Range: same as data range

Type: Status

Supporting information:

PGN 65108

SPN 1774 Engine Maximum Continuous Torque

Applied limit for maximum continuous engine torque.

Data Length: 1 byte

Resolution: 1 %/bit, -125 % offset

Data Range: -125 to 125 % Operational Range: same as data range

Type: Status

Supporting information:

PGN 65108

SPN 1775 Engine Minimum Continuous Torque

Applied limit for minimum continuous engine torque

Data Length: 1 byte

Resolution: 1 %/bit, -125 % offset

Data Range: -125 to 125 % Operational Range: same as data range

Type: Status

Supporting information:

PGN 65108

SPN 1776 *Low Limit Threshold for Maximum RPM from Retarder*

Minimum allowable value for maximum continuous retarder speed

Data Length: 1 byte

Resolution: 32 rpm/bit, 0 offset

Data Range: 0 to 8,000 rpm Operational Range: same as data range

Type: Status

Supporting information:

PGN 65107

SPN 1777 *High Limit Threshold for Minimum Continuous RPM from Retarder*

Maximum allowable value for minimum continuous retarder speed

Data Length: 1 byte

Resolution: 32 rpm/bit, 0 offset

Data Range: 0 to 8,000 rpm Operational Range: same as data range

Type: Status

Supporting information:

PGN 65107

SPN 1778 *Low Limit Threshold for Maximum Torque from Retarder*

Minimum allowable value for maximum continuous retarder torque.

Data Length: 1 byte

Resolution: 1 %/bit, -125 % offset

Data Range: -125 to 125 % Operational Range: same as data range

Type: Status

Supporting information:

PGN 65107

SPN 1779 *High Limit Threshold for Minimum Continuous Torque from Retarder*

Maximum allowable value for minimum continuous retarder torque.

Data Length: 1 byte

Resolution: 1 %/bit, -125 % offset

Data Range: -125 to 125 % Operational Range: same as data range

Type: Status

Supporting information:

PGN 65107

SPN 1780 **Maximum Continuous Retarder Speed**

Applied limit for maximum continuous retarder RPM

Data Length: 1 byte

Resolution: 32 rpm/bit, 0 offset

Data Range: 0 to 8,000 rpm Operational Range: same as data range

Type: Status

Supporting information:

PGN 65107

SPN 1781 **Minimum Continuous Retarder Speed**

Applied limit for minimum continuous retarder RPM

Data Length: 1 byte

Resolution: 32 rpm/bit, 0 offset

Data Range: 0 to 8,000 rpm Operational Range: same as data range

Type: Status

Supporting information:

PGN 65107

SPN 1782 **Maximum Continuous Retarder Torque**

Applied limit for maximum continuous retarder torque.

Data Length: 1 byte

Resolution: 1 %/bit, -125 % offset

Data Range: -125 to 125 % Operational Range: same as data range

Type: Status

Supporting information:

PGN 65107

SPN 1783 **Minimum Continuous Retarder Torque**

Applied limit for minimum continuous retarder torque

Data Length: 1 byte

Resolution: 1 %/bit, -125 % offset

Data Range: -125 to 125 % Operational Range: same as data range

Type: Status

Supporting information:

PGN 65107

SPN 1784 Engine Speed Limit Request - Minimum Continuous

Requested minimum continuous engine speed

Data Length: 1 byte

Resolution: 32 rpm/bit, 0 offset

Data Range: 0 to 8,000 rpm Operational Range: same as data range

Type: Status

Supporting information:

PGN 52992

SPN 1785 Engine Speed Limit Request - Maximum Continuous

Requested maximum continuous engine speed

Data Length: 1 byte

Resolution: 32 rpm/bit, 0 offset

Data Range: 0 to 8,000 rpm Operational Range: same as data range

Type: Status

Supporting information:

PGN 52992

SPN 1786 Engine Torque Limit Request - Minimum Continuous

Requested minimum continuous engine torque (operating range: 0 to 125%)

Data Length: 1 byte

Resolution: 1 %/bit, -125 % offset

Data Range: -125 to 125 % Operational Range: 0 to 125%

Type: Status

Supporting information:

PGN 52992

SPN 1787 Engine Torque Limit Request - Maximum Continuous

Requested maximum continuous engine torque (operating range: 0 to 125%)

Data Length: 1 byte

Resolution: 1 %/bit, -125 % offset

Data Range: -125 to 125 % Operational Range: 0 to 125%

Type: Status

Supporting information:

PGN 52992

SPN 1788 Minimum Continuous Retarder Speed Limit Request

Requested minimum continuous retarder speed

Data Length: 1 byte

Resolution: 32 rpm/bit, 0 offset

Data Range: 0 to 8,000 rpm Operational Range: same as data range

Type: Status

Supporting information:

PGN 52992

SPN 1789 Maximum Continuous Retarder Speed Limit Request

Requested maximum continuous retarder speed

Data Length: 1 byte

Resolution: 32 rpm/bit, 0 offset

Data Range: 0 to 8,000 rpm Operational Range: same as data range

Type: Status

Supporting information:

PGN 52992

SPN 1790 Minimum Continuous Retarder Torque Limit Request

Requested minimum continuous retarder torque (operating range: -125 to 0%)

Data Length: 1 byte

Resolution: 1 %/bit, -125 % offset

Data Range: -125 to 125 % Operational Range: -125 to 0%

Type: Status

Supporting information:

PGN 52992

SPN 1791 Maximum Continuous Retarder Torque Limit Request

Requested maximum continuous retarder torque (operating range: -125 to 0%)

Data Length: 1 byte

Resolution: 1 %/bit, -125 % offset

Data Range: -125 to 125 % Operational Range: -125 to 0%

Type: Status

Supporting information:

PGN 52992

SPN 1792 Tractor-Mounted Trailer ABS Warning Signal

This parameter commands the tractor-mounted trailer ABS optical warning signal.

00 Off
01 On
10 Reserved
11 Take no action

Data Length: 2 bits
Resolution: 4 states/2 bit, 0 offset
Data Range: 0 to 3 Operational Range: same as data range
Type: Status
Supporting information:
PGN 61441

SPN 1793 ATC/ASR Information Signal

This parameter commands the ATC/ASR driver information signal, for example a dash lamp.

00 Off
01 On
10 Reserved
11 Take no action

Data Length: 2 bits
Resolution: 4 states/2 bit, 0 offset
Data Range: 0 to 3 Operational Range: same as data range
Type: Status
Supporting information:
PGN 61441

SPN 1794 Engine Moment of Inertia

Moment of inertia for the engine, including items driven full-time by the engine such as fuel, oil and cooling pumps. The inertia from the following items are not included: flywheel, alternator, compressor, fan, and other engine-driven accessories.

Data Length: 2 bytes
Resolution: 0.004 kg-m²/bit, 0 offset
Data Range: 0 to 257.02 kg-m² Operational Range: same as data range
Type: Status
Supporting information:
PGN 65251

SPN 1795 Alternator Current (High Range/Resolution)

This parameter indicates the amount of electrical current output from the alternator of the main vehicle. Alternator Current (SPN 115) has a lower range and resolution.

Data Length: 2 bytes
Resolution: 0.05 A/bit, -1600 A offset
Data Range: -1600 to 1612.75 A Operational Range: same as data range
Type: Measured
Supporting information:
PGN 65106

SPN 1796 ACC Distance Alert Signal

Signal to indicate to the operator that the ACC system is not able to maintain the distance to the target. Example: Target stopping rapidly. This signal may be used to activate warning sounds or indicators.

00 ACC DAS Not Active
01 ACC DAS Active
10 Reserved
11 Take no action

Data Length: 2 bits
Resolution: 4 states/2 bit, 0 offset
Data Range: 0 to 3 Operational Range: same as data range
Type: Status
Supporting information:
PGN 65135

SPN 1797 ACC System Shutoff Warning

Signal to warn the driver of system deactivation due to non-driver actions. Example: Attempting to control vehicle speed below or above limits of ACC. This signal may be used to activate warning sounds or indicators.

00 ACC SSOW Not Active
01 ACC SSOW Active
10 Reserved
11 Take no action

Data Length: 2 bits
Resolution: 4 states/2 bit, 0 offset
Data Range: 0 to 3 Operational Range: same as data range
Type: Status
Supporting information:
PGN 65135

SPN 1798 ACC Target Detected

Signal to indicate to the driver that the ACC system has detected a target.

00 No targets detected
01 Target detected
10 Reserved
11 Take no action

Data Length: 2 bits
Resolution: 4 states/2 bit, 0 offset
Data Range: 0 to 3 Operational Range: same as data range
Type: Status
Supporting information:
PGN 65135

SPN 1799 Requested ACC Distance Mode

The Requested Distance Control Mode to the ACC system from the operators interface.

The ACC Set Distance Mode (SPN 1589) indicates the selected Distance Control Mode for the ACC system. This parameter is the driver requested setting for this.

000 Requested ACC Distance Mode #1 (largest distance)
 001 Requested ACC Distance Mode #2
 010 Requested ACC Distance Mode #3
 011 Requested ACC Distance Mode #4
 100 Requested ACC Distance Mode #5 (shortest distance)
 101 not defined
 110 error condition
 111 not available

Data Length: 3 bits
 Resolution: 8 states/3 bit, 0 offset
 Data Range: 0 to 7 Operational Range: same as data range
 Type: Measured
 Supporting information:
 PGN 65105

SPN 1800 Battery 1 Temperature

Temperature of the battery 1. The relation to physical location is determined by the equipment manufacturer.

Data Length: 1 byte
 Resolution: 1 deg C/bit, -40 deg C offset
 Data Range: -40 to 210 deg C Operational Range: same as data range
 Type: Measured
 Supporting information:
 PGN 65104

SPN 1801 Battery 2 Temperature

Temperature of the battery 2. The relation to physical location is determined by the equipment manufacturer.

Data Length: 1 byte
 Resolution: 1 deg C/bit, -40 deg C offset
 Data Range: -40 to 210 deg C Operational Range: same as data range
 Type: Measured
 Supporting information:
 PGN 65104

SPN 1802 Engine Intake Manifold 5 Temperature

Temperature of pre-combustion air found in intake manifold number 5 of engine air supply system.

Data Length: 1 byte
 Resolution: 1 deg C/bit, -40 deg C offset
 Data Range: -40 to 210 deg C Operational Range: same as data range
 Type: Measured
 Supporting information:
 PGN 65189

SPN 1803 Engine Intake Manifold 6 Temperature

Temperature of pre-combustion air found in intake manifold number 6 of engine air supply system.

Data Length: 1 byte

Resolution: 1 deg C/bit, -40 deg C offset

Data Range: -40 to 210 deg C Operational Range: same as data range

Type: Measured

Supporting information:

PGN 65189

SPN 1804 Engine Start Enable Device 2

Devices that assist an engine in starting, e.g. intake heaters, ether, or an alternate/secondary starting aid. May be of the same type or different than Start Enable Device 1 (SPN 626). Parameter indicating whether the start enable device 2 is ON or OFF.

00 - start enable OFF

01 - start enable ON

10 - reserved

11 - not available

Data Length: 2 bits

Resolution: 4 states/2 bit, 0 offset

Data Range: 0 to 3 Operational Range: same as data range

Type: Status

Supporting information:

PGN 64966

SPN 1805 LED Display Mode Control

This parameter informs the system what the selected Display mode will be.

0000 - Center On-Grade Display Mode 1 (5 CHANNEL)

0001 - Offset On-Grade Display Mode

0010 - Center On-Grade Display Mode 2 (7 CHANNEL)

0011 - 1110 Reserved

1111 - Not Available or Not Applicable

Data Length: 4 bits

Resolution: 16 states/4 bit, 0 offset

Data Range: 0 to 15 Operational Range: same as data range

Type: Status

Supporting information:

PGN 65142

SPN 1806 LED Display Deadband Control

This parameter informs the system what the selected Display deadband will be.

0000 +/- 4.5 mm (0.015 feet, 0.18 inches)
 0001 +/- 12 mm (0.040 feet, 0.45 inches)
 0010 +/- 24 mm (0.080 feet, 0.96 inches)
 0011 +/- 5 mm (0.017 feet, 0.2 inches)
 0100 +/- 1 mm (0.003 feet, 0.04 inches)
 0101 - 1110 Reserved
 1111 Not Available or Not applicable

Data Length: 4 bits
 Resolution: 16 states/4 bit, 0 offset
 Data Range: 0 to 15 Operational Range: same as data range
 Type: Status
 Supporting information:
 PGN 65142

SPN 1807 Steering Wheel Angle

The main operator's steering wheel angle (on the steering column, not the actual wheel angle). The vehicle being steered to the left results in a positive steering wheel angle.

Data Length: 2 bytes
 Resolution: 1/1024 rad per bit, -31.374 rad offset
 Data Range: -31.374 to +31.374 rad Operational Range: same as data range
 Type: Measured
 Supporting information:
 PGN 61449

SPN 1808 Yaw Rate

Indicates the rotation about the vertical axis. A positive yaw rate signal results when the vehicle turns counter-clockwise.

Data Length: 2 bytes
 Resolution: 1/8192 rad/s per bit, -3.92 rad/s offset
 Data Range: -3.92 to +3.92 rad/s Operational Range: same as data range
 Type: Measured
 Supporting information:
 PGN 61449

SPN 1809 Lateral Acceleration

Indicates a lateral acceleration of the vehicle. A positive lateral acceleration signal results when the vehicle is accelerated to the left.

Data Length: 2 bytes
 Resolution: 1/2048 m/s² per bit, -15.687 m/s² offset
 Data Range: -15.687 to +15.687 m/s² Operational Range: same as data range
 Type: Measured
 Supporting information:
 PGN 61449

SPN 1810 Longitudinal Acceleration

Indicates the longitudinal acceleration of the vehicle. A positive longitudinal acceleration signal results when the vehicle speed increases, regardless of driving the vehicle forward or backward.

Data Length: 1 byte
 Resolution: 0.1 m/s² per bit, -12.5 m/s² offset
 Data Range: -12.5 to +12.5 m/s² Operational Range: same as data range
 Type: Measured
 Supporting information:
 PGN 61449

SPN 1811 Steering Wheel Turn Counter

Indicates number of steering wheel turns, absolute position or relative position at ignition on. Positive values indicate left turns.

Data Length: 6 bits
 Resolution: 1 turn/bit, -32 turns offset
 Data Range: -32 to 29 turns Operational Range: -10 to +10 Turns
 Type: Measured
 Supporting information:
 PGN 61449

SPN 1812 Steering Wheel Angle Sensor Type

Indicates whether the steering wheel angle sensor is capable of absolute measuring of the number of steering wheel turns or not (relative measuring to position at ignition on).

00 Relative measuring principle
 01 Absolute measuring principle
 10 Reserved
 11 Not Available

Data Length: 2 bits
 Resolution: 4 states/2 bit, 0 offset
 Data Range: 0 to 3 Operational Range: same as data range
 Type: Status
 Supporting information:
 PGN 61449

SPN 1813 VDC Information Signal

This parameter commands the VDC information signal, for example a dash lamp.

00 Off
 01 On
 10 Reserved
 11 Don't care/Take no action

Data Length: 2 bits
 Resolution: 4 states/2 bit, 0 offset
 Data Range: 0 to 3 Operational Range: same as data range
 Type: Status
 Supporting information:
 PGN 65103

SPN 1814 VDC Fully Operational

Signal that indicates whether VDC is fully operational or whether its functionality is reduced by a permanent or temporary (e.g. low voltage) defect, by intended action (e.g. disabled by a switch or during special diagnostic procedures), not configured or not yet fully initialized (e.g. missing initialization or configuration message). VDC contains ROP and YC.

00 Not fully operational
 01 Fully operational
 10 Reserved
 11 Don't care/Take no action

Data Length: 2 bits
 Resolution: 4 states/2 bit, 0 offset
 Data Range: 0 to 3 Operational Range: same as data range
 Type: Status
 Supporting information:
 PGN 65103

SPN 1815 VDC brake light request

Indicates whether VDC requests to turn the vehicle brake lights on

00 Turn brake light not on
 01 Turn brake light on
 10 Reserved
 11 Don't care/Take no action

Data Length: 2 bits
 Resolution: 4 states/2 bit, 0 offset
 Data Range: 0 to 3 Operational Range: same as data range
 Type: Status
 Supporting information:
 PGN 65103

SPN 1816 ROP Engine Control active

State Signal which indicates that the Roll Over Prevention (ROP) has commanded engine control to be active. Within the physical limits, ROP attempts to prevent rolling over of the vehicle. Active means that ROP actually tries to control the engine. This state signal is independent of other control commands to the engine which may have higher priority.

00 ROP engine control passive but installed
 01 ROP engine control active
 10 Reserved
 11 Don't care/Take no action

Data Length: 2 bits
 Resolution: 4 states/2 bit, 0 offset
 Data Range: 0 to 3 Operational Range: same as data range
 Type: Status
 Supporting information:
 PGN 65103

SPN 1817 YC Engine Control active

State Signal which indicates that the Yaw Control (YC) has commanded engine control to be active. Within the physical limits, YC attempts to prevent yawing of the vehicle. Active means that YC actually tries to control the engine. This state signal is independent of other control commands to the engine which may have higher priority.

00 YC engine control passive but installed
01 YC engine control active
10 Reserved
11 Don't care/Take no action

Data Length: 2 bits
Resolution: 4 states/2 bit, 0 offset
Data Range: 0 to 3 Operational Range: same as data range
Type: Status
Supporting information:
PGN 65103

SPN 1818 ROP Brake Control active

State signal which indicates that Roll over Prevention (ROP) has activated brake control. Active means that ROP actually controls wheel brake pressure at one or more wheels of the vehicle or vehicle combination. Within the physical limits, ROP attempts to prevent rolling over of the vehicle.

00 ROP brake control passive but installed
01 ROP brake control active
10 Reserved
11 Don't care/Take no action

Data Length: 2 bits
Resolution: 4 states/2 bit, 0 offset
Data Range: 0 to 3 Operational Range: same as data range
Type: Status
Supporting information:
PGN 65103

SPN 1819 YC Brake Control active

State signal which indicates that Yaw Control (YC) has activated brake control. Active means that YC actually controls wheel brake pressure at one or more wheels of the vehicle or vehicle combination. Within the physical limits, YC attempts to prevent yawing of the vehicle.

00 YC brake control passive but installed
01 YC brake control active
10 Reserved
11 Don't care/Take no action

Data Length: 2 bits
Resolution: 4 states/2 bit, 0 offset
Data Range: 0 to 3 Operational Range: same as data range
Type: Status
Supporting information:
PGN 65103

SPN 1820 Ramp / Wheel Chair Lift Position

Signal which indicates the actual position of the ramp / wheel chair lift.

00 Inside bus
01 Outside bus
10 Error
11 Not available

Data Length: 2 bits
Resolution: 4 states/2 bit, 0 offset
Data Range: 0 to 3 Operational Range: same as data range
Type: Measured
Supporting information:
PGN 65102

SPN 1821 Position of doors

Signal which indicates the actual position of the doors.

0000 At least 1 door is open
0001 Closing last door
0010 All doors closed
0011-1101 Not defined
1110 Error
1111 Not available

Data Length: 4 bits
Resolution: 16 states/4 bit, 0 offset
Data Range: 0 to 15 Operational Range: same as data range
Type: Measured
Supporting information:
PGN 65102

SPN 1822 Lift Axle 2 Position

Signal which indicates the position / load condition of lift axle / tag axle #2. Numbering of lift/tag axles starts at front axle.

00 Lift axle position down / tag axle laden
01 Lift axle position up / tag axle unladen
10 Error
11 Not available

Data Length: 2 bits
Resolution: 4 states/2 bit, 0 offset
Data Range: 0 to 3 Operational Range: same as data range
Type: Measured
Supporting information:
PGN 65114

SPN 1823 Rear Axle in Bumper Range

Signal which indicates that the vehicle height at the rear axle (SPNs 1723 and 1724) is within the bumper range.

00 Actual level out of bumper range
01 Actual level within bumper range
10 Error
11 Not available

Data Length: 2 bits
Resolution: 4 states/2 bit, 0 offset
Data Range: 0 to 3 Operational Range: same as data range
Type: Measured
Supporting information:
PGN 65114

SPN 1824 Front Axle in Bumper Range

Signal which indicates that the vehicle height at the front axle (SPNs 1721 and 1722) is within the bumper range.

00 Actual level out of bumper range
01 Actual level within bumper range
10 Error
11 Not available

Data Length: 2 bits
Resolution: 4 states/2 bit, 0 offset
Data Range: 0 to 3 Operational Range: same as data range
Type: Measured
Supporting information:
PGN 65114

SPN 1825 Suspension Remote control 2

Signal which indicates that the suspension system is controlled by remote control #2. Remote control is an external unit to operate the suspension system.

00 Not active
01 Active
10 Error
11 Not available

Data Length: 2 bits
Resolution: 4 states/2 bit, 0 offset
Data Range: 0 to 3 Operational Range: same as data range
Type: Measured
Supporting information:
PGN 65114

SPN 1826 Suspension Remote Control 1

Signal which indicates that the suspension system is controlled by remote control #1. Remote control is an external unit to operate the suspension system.

00 Not active
 01 Active
 10 Error
 11 Not available

Data Length: 2 bits
 Resolution: 4 states/2 bit, 0 offset
 Data Range: 0 to 3 Operational Range: same as data range
 Type: Measured
 Supporting information:
 PGN 65114

SPN 1827 Suspension Control Refusal Information

Signal which indicates that the air suspension control cannot perform a request due to the operating conditions. It also provides a reason for the refusal.

0000 Actual request not refused
 0001 Axle load limit reached (load transfer)
 0010 Would exceed axle load limit (tag axle)
 0011 Bogie differential not locked
 0100 Above speed limit
 0101 Below speed limit
 0110 General reject; i.e. no specified reason applies
 0111 - 1101 Not defined
 1110 Error
 1111 Not available

Data Length: 4 bits
 Resolution: 16 states/4 bit, 0 offset
 Data Range: 0 to 15 Operational Range: same as data range
 Type: Status
 Supporting information:
 PGN 65114

SPN 1828 Lift Axle 2 Position Command

Signal to command the position / load condition of lift / tag axle #2. Numbering of lift/tag axles starts at front axle.

00 Lift axle position down / tag axle laden
 01 Lift axle position up / tag axle unladen
 10 Reserved
 11 Don't care/take no action

Data Length: 2 bits
 Resolution: 4 states/2 bit, 0 offset
 Data Range: 0 to 3 Operational Range: same as data range
 Type: Status
 Supporting information:
 PGN 53760

SPN 1829 *Kneeling Command - Rear Axle*

Command signal to activate the kneeling functionality at the rear axle of the vehicle.

00 Deactivate kneeling
01 Activate kneeling
10 Reserved
11 Don't care/take no action

Data Length: 2 bits
Resolution: 4 states/2 bit, 0 offset
Data Range: 0 to 3 Operational Range: same as data range
Type: Status
Supporting information:
PGN 53760

SPN 1830 *Kneeling Command - Front Axle*

Command signal to activate the kneeling functionality at the front axle of the vehicle

00 Deactivate kneeling
01 Activate kneeling
10 Reserved
11 Don't care/take no action

Data Length: 2 bits
Resolution: 4 states/2 bit, 0 offset
Data Range: 0 to 3 Operational Range: same as data range
Type: Status
Supporting information:
PGN 53760

SPN 1831 *Electronic Shock Absorber Control Mode - Lift/Tag Axle*

Signal which indicates the current mode of operation of the electronic shock absorber control at the lift/tag axle.

00 Normal operation dampers passive
01 Normal operation dampers active
10 Error
11 Not available

Data Length: 2 bits
Resolution: 4 states/2 bit, 0 offset
Data Range: 0 to 3 Operational Range: same as data range
Type: Measured
Supporting information:
PGN 65111

SPN 1832 Electronic Shock Absorber Control Mode - Rear Axle

Signal which indicates the current mode of operation of the electronic shock absorber control at the rear axle.

00 Normal operation dampers passive
 01 Normal operation dampers active
 10 Error
 11 Not available

Data Length: 2 bits
 Resolution: 4 states/2 bit, 0 offset
 Data Range: 0 to 3 Operational Range: same as data range
 Type: Measured
 Supporting information:
 PGN 65111

SPN 1833 Electronic Shock Absorber Control Mode - Front Axle

Signal which indicates the current mode of operation of the electronic shock absorber control at the front axle.

00 Normal operation dampers passive
 01 Normal operation dampers active
 10 Error
 11 Not available

Data Length: 2 bits
 Resolution: 4 states/2 bit, 0 offset
 Data Range: 0 to 3 Operational Range: same as data range
 Type: Measured
 Supporting information:
 PGN 65111

SPN 1834 Engine Total Average Fuel Rate

Average fuel rate, equal to total fuel used divided by total engine hours, over the life of the engine

Data Length: 2 bytes
 Resolution: 0.05 L/h per bit, 0 offset
 Data Range: 0 to 3,212.75 L/h Operational Range: same as data range
 Type: Measured
 Supporting information:
 PGN 65101

SPN 1835 Engine Total Average Fuel Economy

Average fuel economy, equal to total vehicle distance divided by total fuel used, over the life of the engine

Data Length: 2 bytes
 Resolution: 1/512 km/L per bit, 0 offset
 Data Range: 0 to 125.5 km/L Operational Range: same as data range
 Type: Measured
 Supporting information:
 PGN 65101

SPN 1836 Trailer ABS Status

State signal which indicates that ABS in the trailer is actively controlling the brakes. A message is sent to the tractor from the trailer (i.e. by PLC). The receiving device in the tractor transfers this information to the J1939 network. At the beginning of power on the message is sent by the trailer to indicate if this status information is supported. Timeout of the trailer ABS active can be done by monitoring of the Trailer warning light information.

00 Trailer ABS Status Information Available But Not Active
01 Trailer ABS Active
10 Reserved
11 Trailer ABS Status Information Not Available or Parameter Not Supported

Data Length: 2 bits
Resolution: 4 states/2 bit, 0 offset
Data Range: 0 to 3 Operational Range: same as data range
Type: Status
Supporting information:
PGN 61441

SPN 1837 Convoy Driving Lamp Select

Black Out Convoy Driving Lamp Selection

00 Off
01 On
10 Reserved
11 Not Supported

Data Length: 2 bits
Resolution: 4 states/2 bit, 0 offset
Data Range: 0 to 3 Operational Range: same as data range
Type: Status
Supporting information:
PGN 65100

SPN 1838 Convoy Lamp Select

Black Out Convoy Lamp Selection

00 Off
01 On
10 Reserved
11 Not Supported

Data Length: 2 bits
Resolution: 4 states/2 bit, 0 offset
Data Range: 0 to 3 Operational Range: same as data range
Type: Status
Supporting information:
PGN 65100

SPN 1839 Front Black Out Marker Lamp Select

Front Black Out Marker Lamp Selection

00 Off
01 On
10 Reserved
11 Not Supported

Data Length: 2 bits
Resolution: 4 states/2 bit, 0 offset
Data Range: 0 to 3 Operational Range: same as data range
Type: Status
Supporting information:
PGN 65100

SPN 1840 Rear Black Out Marker Select

Rear Black Out Marker Selection

00 Off
01 On
10 Reserved
11 Not Supported

Data Length: 2 bits
Resolution: 4 states/2 bit, 0 offset
Data Range: 0 to 3 Operational Range: same as data range
Type: Status
Supporting information:
PGN 65100

SPN 1841 Black Out Brake/Stop Lamp Select

Black Out Brake/Stop Lamp Selection

00 Off
01 On
10 Reserved
11 Not Supported

Data Length: 2 bits
Resolution: 4 states/2 bit, 0 offset
Data Range: 0 to 3 Operational Range: same as data range
Type: Status
Supporting information:
PGN 65100

SPN 1842 *Black Out Work Lamp Select*

Black Out Work Lamp Selection

00 Off
01 On
10 Reserved
11 Not Supported

Data Length: 2 bits
Resolution: 4 states/2 bit, 0 offset
Data Range: 0 to 3 Operational Range: same as data range
Type: Status
Supporting information:
PGN 65100

SPN 1843 *Night Vision Illuminator Select*

Night Vision Illuminator Selection

00 Off
01 On
10 Reserved
11 Not Supported

Data Length: 2 bits
Resolution: 4 states/2 bit, 0 offset
Data Range: 0 to 3 Operational Range: same as data range
Type: Status
Supporting information:
PGN 65100

SPN 1844 *Operators Black Out Intensity Selection*

Operators Selection of lamp intensity in black out mode. This parameter provides the operators selected illumination intensity as a percentage of available full scale. This parameter would be typically used as a dash or instrument cluster intensity adjustment.

Data Length: 1 byte
Resolution: 0.4 %/bit, 0 offset
Data Range: 0 to 100 % Operational Range: same as data range
Type: Status
Supporting information:
PGN 65100

SPN 1845 Transmission Torque Limit

Parameter provided to the engine from the transmission as a torque limit to be invoked by the engine in the event that J1939 communication with the transmission is lost.

The intention is to protect transmissions that use a continuous torque limit during torque converter mode or operation in specific lower gears, where stall or drivetrain torque may reach levels higher than the gearbox capacity. If communication is lost during torque limited operation, unrestricted engine torque output could harm the transmission.

It is recommended that engines use reception of the ETC#1 message as a transmission "heartbeat". In the event that the ETC#1 message is not received in a time period of 5 times its' broadcast rate (5 x 10 ms = 50 ms), the engine should invoke a torque limit holding the engine to less than or equal to the value of the Transmission Torque Limit parameter. The engine may release the limit when transmission-to-engine communication is re-established.

A value of 0xFF00 to 0xFFFF indicates that no transmission torque limit is desired.

It is expected that the engine will record this torque value in non-volatile memory and will include this in the engine configuration PGN as parameter Engine Default Torque Limit (SPN 1846)

If the engine observes change in this parameter value on power-up, the engine should record the new value.

Data Length: 2 bytes
 Resolution: 1 Nm/bit, 0 offset
 Data Range: 0 to 64,255 Nm Operational Range: same as data range
 Type: Measured
 Supporting information:
 PGN 65099

SPN 1846 Engine Default Torque Limit

Companion parameter to Transmission Torque Limit (SPN 1845). This "echo" parameter provides confirmation to the transmission that the engine has received and will invoke the requested Transmission Torque Limit in the event that J1939 communication is lost between the two devices.

If the engine supports this protection logic, the Engine Default Torque Limit parameter should be set equal to the Transmission Torque Limit parameter as received in the Transmission Configuration 2 message (PGN 65099). Otherwise, an Engine Default Torque Limit value of FF00 to FFFF indicates that no engine default torque limit has been received or set.

The intention is to protect transmissions that use a continuous torque limit during torque converter mode or operation in specific lower gears, where stall or drivetrain torque may reach levels higher than the gearbox capacity. If communication is lost during torque limited operation, unrestricted engine torque output could harm the transmission.

It is recommended that engines use reception of the ETC#1 message as a transmission "heartbeat". In the event that the ETC#1 message is not received in a time period of 5 times its' broadcast rate (5 x 10 ms = 50 ms), the engine should invoke a torque limit holding the engine to less than or equal to the value of the Transmission Torque Limit parameter. The engine may release the limit when engine-to-transmission communication is re-established.

Data Length: 2 bytes
 Resolution: 1 Nm/bit, 0 offset
 Data Range: 0 to 64,255 Nm Operational Range: same as data range
 Type: Measured
 Supporting information:
 PGN 65251

SPN 1849 *Transmission Requested Range Display Flash State*

State signal indicating a transmission request for the display of the Transmission Requested Range parameter (SPN 162) to flash or not to flash. The 'Transmission Requested Range Display Flash State' indicator can be utilized by (but not limited to) the shift console, instrument cluster, or cab display. Definition of the cause of this state is at the discretion of the transmission manufacturer. The flash period shall be 700 ms @ 50% duty cycle.

Transmission manufacturers may want to flash the Transmission Requested Range display depending on certain events. It could be because a gear could not be attained, or because fluid is low, etc. Indicator should be on for 350 ms and off for 350 ms.

Transmissions supporting both this parameter and the Transmission Requested Range Display Blank State should treat the active states of these parameters as mutually exclusive; both parameters should not indicate "active" at the same time.

00 Inactive; Transmission Requested Range display should not be flashing
01 Active; Transmission Requested Range display should be flashing
10 Reserved
11 Take no action

Data Length: 2 bits
Resolution: 4 states/2 bit, 0 offset
Data Range: 0 to 3 Operational Range: same as data range
Type: Status
Supporting information:
PGN 65098

SPN 1850 *Transmission Requested Range Display Blank State*

State signal indicating a transmission request for the display of the Transmission Requested Range parameter (SPN162) to be blanked or not blanked. The 'Transmission Requested Range Display Blank State' indicator can be utilized by (but not limited to) the shift console, instrument cluster, or cab display. Definition of the cause of this state is at the discretion of the transmission manufacturer

Transmission manufacturers may want to blank the Transmission Requested Range display depending on certain events. Typically it is an indication of a shift selector problem.

Transmissions supporting both this parameter and the Transmission Requested Range Display Flash State should treat the active states of these parameters as mutually exclusive; both parameters should not indicate "active" at the same time.

00 Inactive; Transmission Requested Range display should not be blanked
01 Active; Transmission Requested Range display should be blanked
10 Reserved
11 Take no action

Data Length: 2 bits
Resolution: 4 states/2 bit, 0 offset
Data Range: 0 to 3 Operational Range: same as data range
Type: Status
Supporting information:
PGN 65098

SPN 1851 *Transmission Shift Inhibit Indicator*

State signal indicating a transmission request for the Shift Inhibit Indicator to be active or inactive. The shift inhibit indicator can be of lamp or text form, located on (but not limited to) the shift console, instrument cluster, or cab display. Definition of the cause of the 'range inhibit' state is at the discretion of the transmission manufacturer.

Transmission manufacturers may want to indicate that they currently cannot make a requested shift. This could be due to inappropriate vehicle speed or other restrictions.

00 Inactive; shift is not inhibited
 01 Active; shift is inhibited
 10 Reserved
 11 Take no action

Data Length: 2 bits
 Resolution: 4 states/2 bit, 0 offset
 Data Range: 0 to 3 Operational Range: same as data range
 Type: Status
 Supporting information:
 PGN 65098

SPN 1852 *Transmission Mode 1*

Indicates whether transmission mode 1 is enabled. Modes are manufacturer specific and are not necessarily mutually exclusive. See also 2536.

00 Disable
 01 Enable
 10 Reserved
 11 Take no action

Data Length: 2 bits
 Resolution: 4 states/2 bit, 0 offset
 Data Range: 0 to 3 Operational Range: same as data range
 Type: Status
 Supporting information:
 PGN 256

SPN 1853 *Transmission Mode 2*

Indicates whether transmission mode 2 is enabled. Modes are manufacturer specific and are not necessarily mutually exclusive. See also SPN 2537.

00 Disable
 01 Enable
 10 Reserved
 11 Take no action

Data Length: 2 bits
 Resolution: 4 states/2 bit, 0 offset
 Data Range: 0 to 3 Operational Range: same as data range
 Type: Status
 Supporting information:
 PGN 256

SPN 1854 Transmission Mode 3

Indicates whether transmission mode 3 is enabled. Modes are manufacturer specific and are not necessarily mutually exclusive. See also SPN 2538.

00 Disable
01 Enable
10 Reserved
11 Take no action

Data Length: 2 bits
Resolution: 4 states/2 bit, 0 offset
Data Range: 0 to 3 Operational Range: same as data range
Type: Status
Supporting information:
PGN 256

SPN 1855 Transmission Mode 4

Indicates whether transmission mode 4 is enabled. Modes are manufacturer specific and are not necessarily mutually exclusive. See also SPN 2539.

00 Disable
01 Enable
10 Reserved
11 Take no action

Data Length: 2 bits
Resolution: 4 states/2 bit, 0 offset
Data Range: 0 to 3 Operational Range: same as data range
Type: Status
Supporting information:
PGN 256

SPN 1856 Seat Belt Switch

State of switch used to determine if Seat Belt is buckled

00 NOT Buckled
01 OK - Seat Belt is buckled
10 Error - Switch state cannot be determined
11 Not Available

Data Length: 2 bits
Resolution: 4 states/2 bit, 0 offset
Data Range: 0 to 3 Operational Range: same as data range
Type: Measured
Supporting information:
PGN 57344

SPN 1857 Winch Oil Pressure Switch

State of switch used to determine if Winch Oil Pressure is above desired minimum

00 NOT OK- Oil pressure is too low
01 OK - Oil pressure is above minimum
10 Error - Switch state cannot be determined
11 Not Available

Data Length: 2 bits
Resolution: 4 states/2 bit, 0 offset
Data Range: 0 to 3 Operational Range: same as data range
Type: Measured
Supporting information:
PGN 65128

SPN 2347 High Beam Head Light Command

Command to activate or de-activate the tractor high beam head light lamps.

00 De-activate
01 Activate
10 Reserved
11 Don't Care

Data Length: 2 bits
Resolution: 4 states/2 bit, 0 offset
Data Range: 0 to 3 Operational Range: same as data range
Type: Status
Supporting information:
PGN 65089

SPN 2348 High Beam Head Light Data

This parameter provides measured data from the tractor high beam head light lamps.

00 De-activate
01 Activate
10 Fault Detected
11 Not Available

Data Length: 2 bits
Resolution: 4 states/2 bit, 0 offset
Data Range: 0 to 3 Operational Range: same as data range
Type: Measured
Supporting information:
PGN 65088

SPN 2349 *Low Beam Head Light Command*

Command to activate or de-activate the tractor low beam head light lamps.

00 De-activate
01 Activate
10 Reserved
11 Don't Care

Data Length: 2 bits
Resolution: 4 states/2 bit, 0 offset
Data Range: 0 to 3 Operational Range: same as data range
Type: Status
Supporting information:
PGN 65089

SPN 2350 *Low Beam Head Light Data*

This parameter provides measured data from the tractor low beam head light lamps.

00 De-activate
01 Activate
10 Fault Detected
11 Not Available

Data Length: 2 bits
Resolution: 4 states/2 bit, 0 offset
Data Range: 0 to 3 Operational Range: same as data range
Type: Measured
Supporting information:
PGN 65088

SPN 2351 *Alternate Beam Head Light Command*

Command to activate or de-activate the tractor alternate head lights (only low beam is available on alternate head lights).
The alternate position lights are intended for use with loader and snow plows that tend to block the primary head lights.

00 De-activate
01 Activate
10 Reserved
11 Don't Care

Data Length: 2 bits
Resolution: 4 states/2 bit, 0 offset
Data Range: 0 to 3 Operational Range: same as data range
Type: Status
Supporting information:
PGN 65089

SPN 2352 *Alternate Beam Head Light Data*

This parameter provides measured data from the tractor alternate beam head light lamps.

00 De-activate
01 Activate
10 Fault Detected
11 Not Available

Data Length: 2 bits
Resolution: 4 states/2 bit, 0 offset
Data Range: 0 to 3 Operational Range: same as data range
Type: Measured
Supporting information:
PGN 65088

SPN 2353 *Tractor Front Low Mounted Work Lights Command*

Command to activate or de-activate the tractor front low mounted work lights.

00 De-activate
01 Activate
10 Reserved
11 Don't Care

Data Length: 2 bits
Resolution: 4 states/2 bit, 0 offset
Data Range: 0 to 3 Operational Range: same as data range
Type: Status
Supporting information:
PGN 65089

SPN 2354 *Tractor Front Low Mounted Work Lights*

This parameter provides measured data from the tractor front low mounted work lights.

00 De-activate
01 Activate
10 Fault Detected
11 Not Available

Data Length: 2 bits
Resolution: 4 states/2 bit, 0 offset
Data Range: 0 to 3 Operational Range: same as data range
Type: Measured
Supporting information:
PGN 65088

SPN 2355 Tractor Front High Mounted Work Lights Command

Command to activate or de-activate the tractor front high mounted work lights.

00 De-activate
01 Activate
10 Reserved
11 Don't Care

Data Length: 2 bits
Resolution: 4 states/2 bit, 0 offset
Data Range: 0 to 3 Operational Range: same as data range
Type: Status
Supporting information:
PGN 65089

SPN 2356 Tractor Front High Mounted Work Lights

This parameter provides measured data from the tractor front high mounted work lights.

00 De-activate
01 Activate
10 Fault Detected
11 Not Available

Data Length: 2 bits
Resolution: 4 states/2 bit, 0 offset
Data Range: 0 to 3 Operational Range: same as data range
Type: Measured
Supporting information:
PGN 65088

SPN 2357 Tractor Underside Mounted Work Lights Command

Command to activate or de-activate the tractor underside mounted work lights.

00 De-activate
01 Activate
10 Reserved
11 Don't Care

Data Length: 2 bits
Resolution: 4 states/2 bit, 0 offset
Data Range: 0 to 3 Operational Range: same as data range
Type: Status
Supporting information:
PGN 65089

SPN 2358 Tractor Underside Mounted Work Lights

This parameter provides measured data from the tractor underside mounted work lights.

00 De-activate
01 Activate
10 Fault Detected
11 Not Available

Data Length: 2 bits
Resolution: 4 states/2 bit, 0 offset
Data Range: 0 to 3 Operational Range: same as data range
Type: Measured
Supporting information:
PGN 65088

SPN 2359 Tractor Rear Low Mounted Work Lights Command

Command to activate or de-activate the tractor rear low mounted work lights.

00 De-activate
01 Activate
10 Reserved
11 Don't Care

Data Length: 2 bits
Resolution: 4 states/2 bit, 0 offset
Data Range: 0 to 3 Operational Range: same as data range
Type: Status
Supporting information:
PGN 65089

SPN 2360 Tractor Rear Low Mounted Work Lights

This parameter provides measured data from the tractor rear low mounted work lights.

00 De-activate
01 Activate
10 Fault Detected
11 Not Available

Data Length: 2 bits
Resolution: 4 states/2 bit, 0 offset
Data Range: 0 to 3 Operational Range: same as data range
Type: Measured
Supporting information:
PGN 65088

SPN 2361 Tractor Rear High Mounted Work Lights Command

Command to activate or de-activate the tractor rear high mounted work lights.

00 De-activate
01 Activate
10 Reserved
11 Don't Care

Data Length: 2 bits
Resolution: 4 states/2 bit, 0 offset
Data Range: 0 to 3 Operational Range: same as data range
Type: Status
Supporting information:
PGN 65089

SPN 2362 Tractor Rear High Mounted Work Lights

This parameter provides measured data from the tractor rear high mounted work lights.

00 De-activated
01 Activated
10 Fault Detected
11 Not Available

Data Length: 2 bits
Resolution: 4 states/2 bit, 0 offset
Data Range: 0 to 3 Operational Range: same as data range
Type: Measured
Supporting information:
PGN 65088

SPN 2363 Tractor Side Low Mounted Work Lights Command

Command to activate or de-activate the tractor side low mounted work lights.

00 De-activate
01 Activate
10 Reserved
11 Don't Care

Data Length: 2 bits
Resolution: 4 states/2 bit, 0 offset
Data Range: 0 to 3 Operational Range: same as data range
Type: Status
Supporting information:
PGN 65089

SPN 2364 Tractor Side Low Mounted Work Lights

This parameter provides measured data from the tractor side low mounted work lights.

00 De-activated
01 Activated
10 Fault Detected
11 Not Available

Data Length: 2 bits
Resolution: 4 states/2 bit, 0 offset
Data Range: 0 to 3 Operational Range: same as data range
Type: Measured
Supporting information:
PGN 65088

SPN 2365 Tractor Side High Mounted Work Lights Command

Command to activate or de-activate the tractor side high mounted work lights.

00 De-activate
01 Activate
10 Reserved
11 Don't Care

Data Length: 2 bits
Resolution: 4 states/2 bit, 0 offset
Data Range: 0 to 3 Operational Range: same as data range
Type: Status
Supporting information:
PGN 65089

SPN 2366 Tractor Side High Mounted Work Lights

This parameter provides measured data from the tractor side high mounted work lights.

00 De-activated
01 Activated
10 Fault Detected
11 Not Available

Data Length: 2 bits
Resolution: 4 states/2 bit, 0 offset
Data Range: 0 to 3 Operational Range: same as data range
Type: Measured
Supporting information:
PGN 65088

SPN 2367 *Left Turn Signal Lights Command*

Command to activate or de-activate left turn signal lights on the tractor and all connected implements

00 De-activate
01 Activate
10 Reserved
11 Don't Care

Data Length: 2 bits
Resolution: 4 states/2 bit, 0 offset
Data Range: 0 to 3 Operational Range: same as data range
Type: Status
Supporting information:
PGN 65089

SPN 2368 *Left Turn Signal Lights*

This parameter provides measured data from the tractor and attached implement left turn signal lights.

00 De-activated
01 Activated
10 Fault Detected
11 Not Available

Data Length: 2 bits
Resolution: 4 states/2 bit, 0 offset
Data Range: 0 to 3 Operational Range: same as data range
Type: Measured
Supporting information:
PGN 65088

SPN 2369 *Right Turn Signal Lights Command*

Command to activate or de-activate right turn signal lights on the tractor and all connected implements

00 De-activate
01 Activate
10 Reserved
11 Don't Care

Data Length: 2 bits
Resolution: 4 states/2 bit, 0 offset
Data Range: 0 to 3 Operational Range: same as data range
Type: Status
Supporting information:
PGN 65089

SPN 2370 *Right Turn Signal Lights*

This parameter provides measured data from the tractor and attached implement right turn signal lights.

00 De-activated
01 Activated
10 Fault Detected
11 Not Available

Data Length: 2 bits
Resolution: 4 states/2 bit, 0 offset
Data Range: 0 to 3 Operational Range: same as data range
Type: Measured
Supporting information:
PGN 65088

SPN 2371 *Left Stop Light Command*

Command to activate or de-activate the tractor and implement left stop lights

00 De-activate
01 Activate
10 Reserved
11 Don't Care

Data Length: 2 bits
Resolution: 4 states/2 bit, 0 offset
Data Range: 0 to 3 Operational Range: same as data range
Type: Status
Supporting information:
PGN 65089

SPN 2372 *Left Stop Light*

This parameter provides measured data from the tractor and attached implement left stop lights.

00 De-activated
01 Activated
10 Fault Detected
11 Not Available

Data Length: 2 bits
Resolution: 4 states/2 bit, 0 offset
Data Range: 0 to 3 Operational Range: same as data range
Type: Measured
Supporting information:
PGN 65088

SPN 2373 *Right Stop Light Command*

Command to activate or de-activate the tractor and implement right stop light

00 De-activate
01 Activate
10 Reserved
11 Don't Care

Data Length: 2 bits
Resolution: 4 states/2 bit, 0 offset
Data Range: 0 to 3 Operational Range: same as data range
Type: Status
Supporting information:
PGN 65089

SPN 2374 *Right Stop Light*

This parameter provides measured data from the tractor and attached implement right stop lights.

00 De-activated
01 Activated
10 Fault Detected
11 Not Available

Data Length: 2 bits
Resolution: 4 states/2 bit, 0 offset
Data Range: 0 to 3 Operational Range: same as data range
Type: Measured
Supporting information:
PGN 65088

SPN 2375 *Center Stop Light Command*

Command to activate or de-activate the tractor and implement center stop light

00 De-activate
01 Activate
10 Reserved
11 Don't Care

Data Length: 2 bits
Resolution: 4 states/2 bit, 0 offset
Data Range: 0 to 3 Operational Range: same as data range
Type: Status
Supporting information:
PGN 65089

SPN 2376 Center Stop Light

This parameter provides measured data from the tractor and attached implement center stop lights.

00 De-activated
 01 Activated
 10 Fault Detected
 11 Not Available

Data Length: 2 bits
 Resolution: 4 states/2 bit, 0 offset
 Data Range: 0 to 3 Operational Range: same as data range
 Type: Measured
 Supporting information:
 PGN 65088

SPN 2377 Tractor Marker Light Command

Command to activate or de-activate tractor and implement front position lights, rear red tail lights, side amber running lights, license plate lights and instrument and switch back lights.

00 De-activate
 01 Activate
 10 Reserved
 11 Don't Care

Data Length: 2 bits
 Resolution: 4 states/2 bit, 0 offset
 Data Range: 0 to 3 Operational Range: same as data range
 Type: Status
 Supporting information:
 PGN 65089

SPN 2378 Tractor Marker Light

This parameter provides measured data from the tractor and attached implement marker lights, including front position lights, rear tail lights, side running lights, license plate lights and instruments and switch back lights.

00 De-activated
 01 Activated
 10 Fault Detected
 11 Not Available

Data Length: 2 bits
 Resolution: 4 states/2 bit, 0 offset
 Data Range: 0 to 3 Operational Range: same as data range
 Type: Measured
 Supporting information:
 PGN 65088

SPN 2379 *Implement Marker Light Command*

Command to activate or de-activate implement front position lights, rear red tail lights, side amber running lights, license plate lights and instrument and switch back lights.

00 De-activate
01 Activate
10 Reserved
11 Don't Care

Data Length: 2 bits
Resolution: 4 states/2 bit, 0 offset
Data Range: 0 to 3 Operational Range: same as data range
Type: Status
Supporting information:
PGN 65089

SPN 2380 *Implement Marker Light*

This parameter provides measured data from an attached implement marker lights, including front position lights, rear tail lights, side running lights, license plate lights and instruments and switch back lights.

00 De-activated
01 Activated
10 Fault Detected
11 Not Available

Data Length: 2 bits
Resolution: 4 states/2 bit, 0 offset
Data Range: 0 to 3 Operational Range: same as data range
Type: Measured
Supporting information:
PGN 65088

SPN 2381 *Tractor Clearance Light Command*

Command to activate or de-activate the tractor high mounted clearance and center ID lights

00 De-activate
01 Activate
10 Reserved
11 Don't Care

Data Length: 2 bits
Resolution: 4 states/2 bit, 0 offset
Data Range: 0 to 3 Operational Range: same as data range
Type: Status
Supporting information:
PGN 65089

SPN 2382 Tractor Clearance Light

This parameter provides measured data from the tractor high mounted clearance and center ID lights.

00 De-activated
01 Activated
10 Fault Detected
11 Not Available

Data Length: 2 bits
Resolution: 4 states/2 bit, 0 offset
Data Range: 0 to 3 Operational Range: same as data range
Type: Measured
Supporting information:
PGN 65088

SPN 2383 Implement Clearance Light Command

Command to activate or de-activate the implement high mounted clearance and lights.

00 De-activate
01 Activate
10 Reserved
11 Don't Care

Data Length: 2 bits
Resolution: 4 states/2 bit, 0 offset
Data Range: 0 to 3 Operational Range: same as data range
Type: Status
Supporting information:
PGN 65089

SPN 2384 Implement Clearance Light

This parameter provides measured data from an attached implement high mounted clearance lights.

00 De-activated
01 Activated
10 Fault Detected
11 Not Available

Data Length: 2 bits
Resolution: 4 states/2 bit, 0 offset
Data Range: 0 to 3 Operational Range: same as data range
Type: Measured
Supporting information:
PGN 65088

SPN 2385 Rotating Beacon Light Command

Command to activate or de-activate slow moving vehicle indicator lights on tractor and/or implements. Activation of the slow moving vehicle lights implies that the controller should manipulate the lighting as appropriate to provide the slow moving vehicle lighting function.

00 De-activate
01 Activate
10 Reserved
11 Don't Care

Data Length: 2 bits
Resolution: 4 states/2 bit, 0 offset
Data Range: 0 to 3 Operational Range: same as data range
Type: Status
Supporting information:
PGN 65089

SPN 2386 Rotating Beacon Light

This parameter provides measured data from the beacon light on tractor or attached implements.

00 De-activated
01 Activated
10 Fault Detected
11 Not Available

Data Length: 2 bits
Resolution: 4 states/2 bit, 0 offset
Data Range: 0 to 3 Operational Range: same as data range
Type: Measured
Supporting information:
PGN 65088

SPN 2387 Tractor Front Fog Lights Command

Command to activate or de-activate tractor front fog lights.

00 De-activate
01 Activate
10 Reserved
11 Don't Care

Data Length: 2 bits
Resolution: 4 states/2 bit, 0 offset
Data Range: 0 to 3 Operational Range: same as data range
Type: Status
Supporting information:
PGN 65089

SPN 2388 Tractor Front Fog Lights

This parameter provides measured data from the tractor front fog lights.

00 De-activated
01 Activated
10 Fault Detected
11 Not Available

Data Length: 2 bits
Resolution: 4 states/2 bit, 0 offset
Data Range: 0 to 3 Operational Range: same as data range
Type: Measured
Supporting information:
PGN 65088

SPN 2389 Rear Fog Light Command

Command to activate or de-activate tractor or implement rear fog lights.

00 De-activate
01 Activate
10 Reserved
11 Don't Care

Data Length: 2 bits
Resolution: 4 states/2 bit, 0 offset
Data Range: 0 to 3 Operational Range: same as data range
Type: Status
Supporting information:
PGN 65089

SPN 2390 Rear Fog Lights

This parameter provides measured data from the tractor and/or implement rear fog lights.

00 De-activated
01 Activated
10 Fault Detected
11 Not Available

Data Length: 2 bits
Resolution: 4 states/2 bit, 0 offset
Data Range: 0 to 3 Operational Range: same as data range
Type: Measured
Supporting information:
PGN 65088

SPN 2391 Back Up Light and Alarm Horn Command

Command to activate or de-activate the back up lights and/ or associated alarm if required

00 De-activate
01 Activate
10 Reserved
11 Don't Care

Data Length: 2 bits
Resolution: 4 states/2 bit, 0 offset
Data Range: 0 to 3 Operational Range: same as data range
Type: Status
Supporting information:
PGN 65089

SPN 2392 Back Up Light and Alarm Horn

This parameter provides measured data from the back up lights and/ or associated alarm.

00 De-activated
01 Activated
10 Fault Detected
11 Not Available

Data Length: 2 bits
Resolution: 4 states/2 bit, 0 offset
Data Range: 0 to 3 Operational Range: same as data range
Type: Measured
Supporting information:
PGN 65088

SPN 2393 Lighting Data Request Command

Command to provide a response of the light state

00 De-activate
01 Activate
10 Reserved
11 Don't Care

Data Length: 2 bits
Resolution: 4 states/2 bit, 0 offset
Data Range: 0 to 3 Operational Range: same as data range
Type: Status
Supporting information:
PGN 65089

SPN 2394 *Implement Rear Work Light*

This parameter provides measured data from the implement rear work lamps.

00 De-activate
01 Activate
10 Fault Detected
11 Not Available

Data Length: 2 bits
Resolution: 4 states/2 bit, 0 offset
Data Range: 0 to 3 Operational Range: same as data range
Type: Measured
Supporting information:
PGN 65088

SPN 2395 *Implement OEM Option 1 Light Command*

Command to activate or de-activate an implement OEM option 1 light. This is provided to meet special needs on implements, such as tank inspection or filling lights.

00 De-activate
01 Activate
10 Reserved
11 Don't Care

Data Length: 2 bits
Resolution: 4 states/2 bit, 0 offset
Data Range: 0 to 3 Operational Range: same as data range
Type: Status
Supporting information:
PGN 65089

SPN 2396 *Implement OEM Option 1 Light*

This parameter provides measured data from the implement OEM option 1 light.

00 De-activate
01 Activate
10 Fault Detected
11 Not Available

Data Length: 2 bits
Resolution: 4 states/2 bit, 0 offset
Data Range: 0 to 3 Operational Range: same as data range
Type: Measured
Supporting information:
PGN 65088

SPN 2397 *Implement OEM Option 2 Light Command*

Command to activate or de-activate an implement OEM option 2 light. This is provided to meet special needs on implements, such as tank inspection or filling lights.

00 De-activate
01 Activate
10 Reserved
11 Don't Care

Data Length: 2 bits
Resolution: 4 states/2 bit, 0 offset
Data Range: 0 to 3 Operational Range: same as data range
Type: Status
Supporting information:
PGN 65089

SPN 2398 *Implement OEM Option 2 Light*

This parameter provides measured data from the implement OEM option 2 light.

00 De-activate
01 Activate
10 Fault Detected
11 Not Available

Data Length: 2 bits
Resolution: 4 states/2 bit, 0 offset
Data Range: 0 to 3 Operational Range: same as data range
Type: Measured
Supporting information:
PGN 65088

SPN 2399 *Implement Left Forward Work Light Command*

Command to activate or de-activate the forward facing work lights toward the left end of the implement.

00 De-activate
01 Activate
10 Reserved
11 Don't Care

Data Length: 2 bits
Resolution: 4 states/2 bit, 0 offset
Data Range: 0 to 3 Operational Range: same as data range
Type: Status
Supporting information:
PGN 65089

SPN 2400 *Implement Left Forward Work Light*

This parameter provides measured data from the forward facing work lights toward the left end of the implement.

00 De-activate
01 Activate
10 Fault Detected
11 Not Available

Data Length: 2 bits
Resolution: 4 states/2 bit, 0 offset
Data Range: 0 to 3 Operational Range: same as data range
Type: Measured
Supporting information:
PGN 65088

SPN 2401 *Implement Right Forward Work Light Command*

Command to activate or de-activate the forward facing work lights toward the right end of the implement.

00 De-activate
01 Activate
10 Reserved
11 Don't Care

Data Length: 2 bits
Resolution: 4 states/2 bit, 0 offset
Data Range: 0 to 3 Operational Range: same as data range
Type: Status
Supporting information:
PGN 65089

SPN 2402 *Implement Right Forward Work Light*

This parameter provides measured data from the forward facing work lights toward the right end of the implement.

00 De-activate
01 Activate
10 Fault Detected
11 Not Available

Data Length: 2 bits
Resolution: 4 states/2 bit, 0 offset
Data Range: 0 to 3 Operational Range: same as data range
Type: Measured
Supporting information:
PGN 65088

SPN 2403 *Running Light Command*

Command to activate or de-activate the tractor or powered vehicle running lights. Usually only used for on road vehicles.

00 De-activate
01 Activate
10 Reserved
11 Don't care

Data Length: 2 bits
Resolution: 4 states/2 bit, 0 offset
Data Range: 0 to 3 Operational Range: same as data range
Type: Status
Supporting information:
PGN 65089

SPN 2404 *Running Light*

This parameter provides measured data from the vehicle's running lights.

00 De-activate
01 Activate
10 Fault Detected
11 Not Available

Data Length: 2 bits
Resolution: 4 states/2 bit, 0 offset
Data Range: 0 to 3 Operational Range: same as data range
Type: Measured
Supporting information:
PGN 65088

SPN 2405 *Implement Rear Work Light Command*

Command to activate or de-activate implement rear work lights. (This is also the same as Reversing Lights for truck applications.)

00 De-activate
01 Activate
10 Reserved
11 Don't Care

Data Length: 2 bits
Resolution: 4 states/2 bit, 0 offset
Data Range: 0 to 3 Operational Range: same as data range
Type: Status
Supporting information:
PGN 65089

SPN 2406 Implement Right Facing Work Light Command

Command to activate or de-activate work lights mounted on an implement to illuminate beyond right end of the implement.

00 De-activate
01 Activate
10 Reserved
11 Don't Care

Data Length: 2 bits
Resolution: 4 states/2 bit, 0 offset
Data Range: 0 to 3 Operational Range: same as data range
Type: Status
Supporting information:
PGN 65089

SPN 2407 Implement Right Facing Work Light

This parameter provides measured data from the work lights mounted on an implement to illuminate beyond right end of the implement.

00 De-activate
01 Activate
10 Fault Detected
11 Not Available

Data Length: 2 bits
Resolution: 4 states/2 bit, 0 offset
Data Range: 0 to 3 Operational Range: same as data range
Type: Measured
Supporting information:
PGN 65088

SPN 2432 Engine Demand – Percent Torque

The requested torque output of the engine by all dynamic internal inputs, including smoke control, noise control and low and high speed governing.

Data Length: 1 byte
Resolution: 1 %/bit, -125 % offset
Data Range: -125 to 125 % Operational Range: -125% to +125%
Type: Measured
Supporting information: See Appendix D - SPN 2432
PGN 61444

SPN 2433 Engine Exhaust Gas Temperature - Right Manifold

Temperature of combustion byproducts within the right engine exhaust manifold. Single manifold engines should use exhaust temperature (SPN 173).

Data Length: 2 bytes
Resolution: 0.03125 deg C/bit, -273 deg C offset
Data Range: -273 to 1735 deg C Operational Range: same as data range
Type: Measured
Supporting information:
PGN 65031

SPN 2434 Engine Exhaust Gas Temperature - Left Manifold

Temperature of combustion byproducts within the left engine exhaust manifold. Single manifold engines should use exhaust temperature (SPN 173).

Data Length: 2 bytes
Resolution: 0.03125 deg C/bit, -273 deg C offset
Data Range: -273 to 1735 deg C Operational Range: same as data range
Type: Measured
Supporting information:
PGN 65031

SPN 2435 Sea Water Pump Outlet Pressure

Gauge pressure of liquid found at outlet of sea water pump in sea water cooling system.

Data Length: 1 byte
Resolution: 2 kPa/bit, 0 offset
Data Range: 0 to 500 kPa Operational Range: same as data range
Type: Measured
Supporting information:
PGN 65172

SPN 2536 Transmission Mode 1 Indicator

This state signal is the transmission's indication that it is operating under transmission mode 1 (SPN 1852) as commanded via the TC1 message (PGN 256). The definition of the transmission mode is left to the discretion of the transmission manufacturer.

00 Transmission Mode 1 not active
01 Transmission Mode 1 Active
10 Error
11 Not available

Data Length: 2 bits
Resolution: 4 states/2 bit, 0 offset
Data Range: 0 to 3 Operational Range: same as data range
Type: Status
Supporting information:
PGN 65098

SPN 2537 Transmission Mode 2 Indicator

This state signal is the transmission's indication that it is operating under transmission mode 2 (SPN 1853) as commanded via the TC1 message (PGN 256). The definition of the transmission mode is left to the discretion of the transmission manufacturer.

00 Transmission Mode 2 not active
01 Transmission Mode 2 Active
10 Error
11 Not available

Data Length: 2 bits
Resolution: 4 states/2 bit, 0 offset
Data Range: 0 to 3 Operational Range: same as data range
Type: Status
Supporting information:
PGN 65098

SPN 2538 Transmission Mode 3 Indicator

This state signal is the transmission's indication that it is operating under transmission mode 3 (SPN 1854) as commanded via the TC1 message (PGN 256). The definition of the transmission mode is left to the discretion of the transmission manufacturer.

00 Transmission Mode 3 not active
01 Transmission Mode 3 Active
10 Error
11 Not available

Data Length: 2 bits
Resolution: 4 states/2 bit, 0 offset
Data Range: 0 to 3 Operational Range: same as data range
Type: Status
Supporting information:
PGN 65098

SPN 2539 Transmission Mode 4 Indicator

This state signal is the transmission's indication that it is operating under transmission mode 4 (SPN 1855) as commanded via the TC1 message (PGN 256). The definition of the transmission mode is left to the discretion of the transmission manufacturer.

00 Transmission Mode 4 not active
01 Transmission Mode 4 Active
10 Error
11 Not available

Data Length: 2 bits
Resolution: 4 states/2 bit, 0 offset
Data Range: 0 to 3 Operational Range: same as data range
Type: Status
Supporting information:
PGN 65098

SPN 2576 Laser Receiver Type

Identifies which type of Laser Receiver transmitted the message.

0 = Reserved
1 = Linear Laser Receiver
2 = 1 Meter Survey Receiver
3 = 2 Meter Survey Receiver
4 = 2.5 Meter Survey Receiver
5-250 = Reserved

Data Length: 1 byte
Resolution: 1 count/bit, 0 offset
Data Range: 0 to 250 Operational Range: 1-4
Type: Status
Supporting information:
PGN 65141

SPN 2577 *Display Deadbands*

Sets Display Deadbands mode.

0000 - Narrow = +/- 4.5mm
0001 - Standard = +/- 12mm
0010 - Wide = +/- 24mm
0011 - 1110 Reserved
1111 Not Available

Data Length: 4 bits
Resolution: 16 states/4 bit, 0 offset
Data Range: 0 to 15 Operational Range: same as data range
Type: Status
Supporting information:
PGN 65142

SPN 2578 *LED Pattern Control*

Sets LED Pattern control mode on laser leveling systems.

0000 - 5 Channel
0001 - Offset
0010 - 7 Channel
0011 - 1110 Reserved
1111 Not Available

Data Length: 4 bits
Resolution: 16 states/4 bit, 0 offset
Data Range: 0 to 15 Operational Range: same as data range
Type: Status
Supporting information:
PGN 65142

SPN 2579 *Net Battery Current (High Range/Resolution)*

Net flow of electrical current into/out-of the battery or batteries. This parameter is the high range and resolution of SPN 114 - Net Battery Current.

Data Length: 2 bytes
Resolution: 0.05 A/bit, -1600 A offset
Data Range: -1600 to 1612.75 A Operational Range: same as data range
Type: Measured
Supporting information:
PGN 65106

SPN 2580 *Hydraulic Brake Pressure Circuit 1*

Gage hydraulic pressure in circuit 1 of the hydraulic brake system

Data Length: 1 byte
Resolution: 100 kPa/bit, 0 offset
Data Range: 0 to 25 MPa Operational Range: same as data range
Type: Measured
Supporting information:
PGN 64998

SPN 2581 Hydraulic Brake Pressure Circuit 2

Gage hydraulic pressure in circuit 2 of the hydraulic brake system

Data Length: 1 byte

Resolution: 100 kPa/bit, 0 offset

Data Range: 0 to 25 MPa Operational Range: same as data range

Type: Measured

Supporting information:

PGN 64998

SPN 2582 Hydraulic Brake Pressure Supply State Circuit 1

Signal which indicates whether the hydraulic brake pressure supply of circuit 1 is reliable; that is, able to support continued braking.

00 Supply is not reliable

01 Supply is reliable

10 Error indicator

11 Not available

Data Length: 2 bits

Resolution: 4 states/2 bit, 0 offset

Data Range: 0 to 3 Operational Range: same as data range

Type: Measured

Supporting information:

PGN 64998

SPN 2583 Hydraulic Brake Pressure Supply State Circuit 2

Signal which indicates whether the hydraulic brake pressure supply of circuit 2 is reliable; that is, able to support continued braking.

00 Supply is not reliable

01 Supply is reliable

10 Error indicator

11 Not available

Data Length: 2 bits

Resolution: 4 states/2 bit, 0 offset

Data Range: 0 to 3 Operational Range: same as data range

Type: Measured

Supporting information:

PGN 64998

SPN 2584 Hydraulic Brake Pressure Warning State Circuit 1

Signal which indicates whether the hydraulic brake pressure of circuit 1 is below the warning level

00 Pressure level sufficient
01 Pressure level below warning level
10 Error indicator
11 Not available

Data Length: 2 bits
Resolution: 4 states/2 bit, 0 offset
Data Range: 0 to 3 Operational Range: same as data range
Type: Measured
Supporting information:
PGN 64998

SPN 2585 Hydraulic Brake Pressure Warning State Circuit 2

Signal which indicates whether the hydraulic brake pressure of circuit 2 is below the warning level

00 Pressure level sufficient
01 Pressure level below warning level
10 Error indicator
11 Not available

Data Length: 2 bits
Resolution: 4 states/2 bit, 0 offset
Data Range: 0 to 3 Operational Range: same as data range
Type: Measured
Supporting information:
PGN 64998

SPN 2586 Tire Air Leakage Rate

The pressure loss rate of a tire.

Data Length: 2 bytes
Resolution: 0.1 Pa/s per bit, 0 offset
Data Range: 0 Pa/s to 6425.5 Pa/s Operational Range: same as data range
Type: Measured
Supporting information:
PGN 65268

SPN 2587 *Tire Pressure Threshold Detection*

Signal indicating the pressure level of the tire. The levels defined represent different pressure conditions of the tire:

000 Extreme over pressure - The tire pressure is at a level where the safety of the vehicle may be jeopardised.
001 Over pressure - The tire pressure is higher than the pressure defined by the vehicle or tire manufacturer.
010 No warning pressure - The tire pressure is within the thresholds defined by the vehicle or tire manufacturer.
011 Under pressure - The tire pressure is lower than the pressure defined by the vehicle or tire manufacturer.
100 Extreme under pressure - The tire pressure is at a level where the safety of the vehicle may be jeopardised.
101 Not defined
110 Error indicator
111 Not available

Data Length: 3 bits
Resolution: 8 states/3 bit, 0 offset
Data Range: 0 to 7 Operational Range: same as data range
Type: Measured
Supporting information:
PGN 65268

SPN 2588 *Maximum Vehicle Speed Limit 1*

The lowest Maximum Vehicle Speed Limit. This value is the similar to SPN 74. However, SPN 74 was not specifically defined to convey the applied vehicle speed limit or what was possible to be applied. This new SPN is the lowest vehicle speed limit that is possible. Additionally, the lowest vehicle speed limit shall be applied when the J1939 network is no longer providing input regarding the Selected Maximum Vehicle Speed Limit. Exceptions to this exist when the device performing the maximum vehicle speed limiting function has methods of selecting the thresholds separately from the Selected Maximum Vehicle Speed Limit parameter.

Data Length: 1 byte
Resolution: 1 km/h per bit, 0 offset
Data Range: 0 to 250 km/h Operational Range: same as data range
Type: Status
Supporting information:
PGN 64997

SPN 2589 *Maximum Vehicle Speed Limit 2*

The highest of the two lowest vehicle speed limits

Data Length: 1 byte
Resolution: 1 km/h per bit, 0 offset
Data Range: 0 to 250 km/h Operational Range: same as data range
Type: Status
Supporting information:
PGN 64997

SPN 2590 *Maximum Vehicle Speed Limit 3*

The highest of the three lowest vehicle speed limits

Data Length: 1 byte
Resolution: 1 km/h per bit, 0 offset
Data Range: 0 to 250 km/h Operational Range: same as data range
Type: Status
Supporting information:
PGN 64997

SPN 2591 **Maximum Vehicle Speed Limit 4**

The highest of the four lowest vehicle speed limits

Data Length: 1 byte

Resolution: 1 km/h per bit, 0 offset

Data Range: 0 to 250 km/h Operational Range: same as data range

Type: Status

Supporting information:

PGN 64997

SPN 2592 **Maximum Vehicle Speed Limit 5**

The highest of the five lowest vehicle speed limits

Data Length: 1 byte

Resolution: 1 km/h per bit, 0 offset

Data Range: 0 to 250 km/h Operational Range: same as data range

Type: Status

Supporting information:

PGN 64997

SPN 2593 **Maximum Vehicle Speed Limit 6**

The highest of the six lowest vehicle speed limits

Data Length: 1 byte

Resolution: 1 km/h per bit, 0 offset

Data Range: 0 to 250 km/h Operational Range: same as data range

Type: Status

Supporting information:

PGN 64997

SPN 2594 **Maximum Vehicle Speed Limit 7**

The highest of the seven lowest vehicle speed limits

Data Length: 1 byte

Resolution: 1 km/h per bit, 0 offset

Data Range: 0 to 250 km/h Operational Range: same as data range

Type: Status

Supporting information:

PGN 64997

SPN 2595 Applied Vehicle Speed Limit

The vehicle speed limit in effect.

Data Length: 1 byte

Resolution: 1 km/h per bit, 0 offset

Data Range: 0 to 250 km/h

Operational Range: same as data range

Type: Status

Supporting information:

PGN 64997

SPN 2596 Selected Maximum Vehicle Speed Limit

User selected maximum vehicle speed, must equal one of the maximum vehicle speeds #1-#7 from PGN 64997 - maximum vehicle speed limit status . If different maximum vehicle speed requests are present from different devices, the lowest requested value should be used.

Data Length: 1 byte

Resolution: 1 count/bit, 0 offset

Data Range: 0 to 250

Operational Range: 1 through 7 are allowed. 8 through 250 are not allowed.

Type: Status

Supporting information:

PGN 57344

SPN 2597 Implement Left Facing Work Light Command

Command to activate or de-activate work lights mounted on an implement to illuminate beyond left end of the implement.

00 De-activate

01 Activate

10 Reserved

11 Don't Care

Data Length: 2 bits

Resolution: 4 states/2 bit, 0 offset

Data Range: 0 to 3

Operational Range: same as data range

Type: Status

Supporting information:

PGN 65089

SPN 2598 Implement Left Facing Work Light

This parameter provides measured data from the work lights mounted on an implement to illuminate beyond left end of the implement.

00 De-activate

01 Activate

10 Fault Detected

11 Not Available

Data Length: 2 bits

Resolution: 4 states/2 bit, 0 offset

Data Range: 0 to 3

Operational Range: same as data range

Type: Measured

Supporting information:

PGN 65088

SPN 2599 Fire Apparatus Pump Engagement

The measured status of the pump used to provide water in fire fighting apparatus for distribution of water through water cannons or fire hoses.

00 Pump not engaged
01 Pump engaged
10 Error
11 Not available or not installed

Data Length: 2 bits
Resolution: 4 states/2 bit, 0 offset
Data Range: 0 to 3 Operational Range: same as data range
Type: Measured
Supporting information:
PGN 61448

SPN 2600 Payload Percentage

The current payload of the equipment, reported as a percentage of the equipment's rated payload limit.

Data Length: 1 byte
Resolution: 1 %/bit, 0 offset
Data Range: 0 to 250 % Operational Range: same as data range
Type: Measured
Supporting information:
PGN 64996

SPN 2601 Travel Velocity Control Position

The position of the travel velocity control component reported as a percentage of the control's full displacement in each direction respectively. Positive position values indicate forward travel direction; negative position values indicate reverse, or backward, travel direction; and zero (0) percent position indicates the control device is in the neutral position. Higher percent for a particular travel direction indicates a higher desired travel speed in that direction.

Data Length: 1 byte
Resolution: 1 %/bit, -125 % offset
Data Range: -125 to 125 % Operational Range: same as data range
Type: Measured
Supporting information:
PGN 64995

SPN 2602 Hydraulic Oil Level

This parameter indicates the level of the hydraulic fluid in tank as a ratio of current volume to total tank volume. This parameter is intended for reporting the hydraulic fluid level in the system tank or reservoir. This hydraulic fluid is for the entire hydraulics system of a piece of equipment.

Data Length: 1 byte
Resolution: 0.4 %/bit, 0 offset
Data Range: 0 to 100 % Operational Range: same as data range
Type: Measured
Supporting information:
PGN 65128

SPN 2603 *Pneumatic Supply Pressure Request*

Command signal to influence the pneumatic pressure in the main reservoir. This parameter is the setpoint for the parameter SPN 46.

Data Length: 1 byte
Resolution: 8 kPa/bit, 0 offset
Data Range: 0 to 2,000 kPa Operational Range: same as data range
Type: Status
Supporting information:
PGN 64994

SPN 2604 *Parking and/or Trailer Air Pressure Request*

Command signal to influence the pneumatic pressure in the circuit or reservoir for the parking brake and/or the trailer supply. This parameter is the setpoint for the parameter SPN 1086.

Data Length: 1 byte
Resolution: 8 kPa/bit, 0 offset
Data Range: 0 to 2,000 kPa Operational Range: same as data range
Type: Status
Supporting information:
PGN 64994

SPN 2605 *Service Brake Air Pressure Request, Circuit #1*

Command signal to influence the pneumatic pressure in the service brake circuit or reservoir #1. This parameter is the setpoint for the parameter SPN 1087.

Data Length: 1 byte
Resolution: 8 kPa/bit, 0 offset
Data Range: 0 to 2,000 kPa Operational Range: same as data range
Type: Status
Supporting information:
PGN 64994

SPN 2606 *Service Brake Air Pressure Request, Circuit #2*

Command signal to influence the pneumatic pressure in the service brake circuit or reservoir #2. This parameter is the setpoint for the parameter SPN 1088.

Data Length: 1 byte
Resolution: 8 kPa/bit, 0 offset
Data Range: 0 to 2,000 kPa Operational Range: same as data range
Type: Status
Supporting information:
PGN 64994

SPN 2607 Auxiliary Equipment Supply Pressure Request

Command signal to influence the pneumatic pressure in the auxiliary circuit. This parameter is the setpoint for the parameter SPN 1089.

Data Length: 1 byte
Resolution: 8 kPa/bit, 0 offset
Data Range: 0 to 2,000 kPa Operational Range: same as data range
Type: Status
Supporting information:
PGN 64994

SPN 2608 Air Suspension Supply Pressure Request

Command signal to influence the pneumatic pressure in the circuit for the electronically controlled air suspension system. This parameter is the setpoint for the parameter SPN 1090.

Data Length: 1 byte
Resolution: 8 kPa/bit, 0 offset
Data Range: 0 to 2,000 kPa Operational Range: same as data range
Type: Status
Supporting information:
PGN 64994

SPN 2609 Cab A/C Refrigerant Compressor Outlet Pressure

This is the gage pressure at the compressor outlet in the cab air conditioning system.

Data Length: 1 byte
Resolution: 16 kPa/bit, 0 offset
Data Range: 0 to 4000 kPa Operational Range: same as data range
Type: Measured
Supporting information:
PGN 64993

SPN 2610 Solar Intensity Percent

This is the solar radiation (power density) falling on the vehicle in percent of the maximum sensor value (SPN 2611). Currently this is in the infra-red spectrum.

Data Length: 1 byte
Resolution: 0.4 %/bit, 0 offset
Data Range: 0 to 100 % Operational Range: same as data range
Type: Measured
Supporting information:
PGN 64992

SPN 2611 *Solar Sensor Maximum*

This is the maximum value which can be reported by the sensor for the solar intensity. (This is a configuration parameter)

Data Length: 1 byte

Resolution: 0.4 mW/cm² per bit, 0 offset

Data Range: 0 to 100 mW/cm² Operational Range: same as data range

Type: Status

Supporting information:

PGN 64992

SPN 2612 *Front Wheel Drive Actuator Status*

Feedback on the front wheel drive actuator.

00 Front Wheel Drive Actuator not engaged

01 Front Wheel Drive Actuator engaged

10 Error

11 Not Available

Data Length: 2 bits

Resolution: 4 states/2 bit, 0 offset

Data Range: 0 to 3 Operational Range: same as data range

Type: Measured

Supporting information:

PGN 64991

SPN 2613 *Drive Axle Lube Pressure*

The drive axle lubricant pressure with location determined by Drive Axle Location (SPN 930).

Data Length: 1 byte

Resolution: 4 kPa/bit, 0 offset

Data Range: 0 to 1000 kPa Operational Range: same as data range

Type: Measured

Supporting information:

PGN 65273

SPN 2614 *Steering Axle Lube Pressure*

The steering axle lubricant pressure.

Data Length: 1 byte

Resolution: 4 kPa/bit, 0 offset

Data Range: 0 to 1000 kPa Operational Range: same as data range

Type: Measured

Supporting information:

PGN 65273

SPN 2615 Engine Throttle Synchronization Mode Status

The status of the Throttle Synchronization Mode. Throttle Synchronization Mode is used to indicate which throttle, if any, is currently being used for the synchronized throttle.

0000 Not Synchronized
0001 Synchronized Center
0010 Synchronized Port
0011 Synchronized Starboard
0100 Synchronized Master
0101-1110 Reserved
1111 Take no action

Data Length: 4 bits
Resolution: 16 states/4 bit, 0 offset
Data Range: 0 to 15 Operational Range: same as data range
Type: Status
Supporting information:
PGN 64988

SPN 2616 Trolling Mode Status

The status of the Trolling Mode. Trolling mode limits the top speed. Full range travel of the throttle level spans from low idle engine speed to maximum trolling speed.

00 Trolling mode is OFF.
01 Trolling mode is ACTIVE.
10 Reserved
11 Take no action

Data Length: 2 bits
Resolution: 4 states/2 bit, 0 offset
Data Range: 0 to 3 Operational Range: same as data range
Type: Status
Supporting information:
PGN 64988

SPN 2617 Slow Vessel Mode Status

The status of the Slow Vessel Mode. Slow Vessel Mode puts the engine in a lower-than-normal low idle speed during docking or other slow vessel operations.

00 Slow vessel mode is OFF.
01 Slow vessel mode is ACTIVE.
10 Reserved
11 Take no action

Data Length: 2 bits
Resolution: 4 states/2 bit, 0 offset
Data Range: 0 to 3 Operational Range: same as data range
Type: Status
Supporting information:
PGN 64988

SPN 2629 Engine Turbocharger 1 Compressor Outlet Temperature

Temperature of the air exiting the turbocharger 1 compressor outlet

Data Length: 2 bytes

Resolution: 0.03125 deg C/bit, -273 deg C offset

Data Range: -273 to 1735 deg C Operational Range: same as data range

Type: Measured

Supporting information:

PGN 64979

SPN 2630 Engine Charge Air Cooler Outlet Temperature

Temperature of combustion air after it exits from the Charge Air Cooler but before any mixing of Recirculated Exhaust Gas.

Data Length: 2 bytes

Resolution: 0.03125 deg C/bit, -273 deg C offset

Data Range: -273 to 1735 deg C Operational Range: same as data range

Type: Measured

Supporting information:

PGN 65129

SPN 2631 Engine Charge Air Cooler Outlet Pressure

Measures pressure of air at outlet from charge air cooler

Data Length: 1 byte

Resolution: 2 kPa/bit, 0 offset

Data Range: 0 to 500 kPa Operational Range: same as data range

Type: Measured

Supporting information:

PGN 64938

SPN 2659 Engine Exhaust Gas Recirculation (EGR) Mass Flow Rate

Flow rate of gas through the EGR system. Flow rate of the exhaust gas being recirculated into the combustion air.

Data Length: 2 bytes

Resolution: 0.05 kg/h per bit, 0 offset

Data Range: 0 to 3212.75 kg/h Operational Range: same as data range

Type: Measured

Supporting information:

PGN 61450

SPN 2660 Joystick 1 X-Axis Position

The position of the joystick in the relative motion of travel from the neutral position. Position value of 0 is Neutral and position value 1000 (100%) is the end of linear zone. Value of 1022 indicates an error has occurred.

Data Length: 10 bits
Resolution: 0.1 %/bit, 0 offset
Data Range: 0 to 102 % Operational Range: 0.0 to 100.0%
Type: Measured
Supporting information:
PGN 64982

SPN 2661 Joystick 1 Y-Axis Position

The position of the joystick in the relative motion of travel from the neutral position. Position value of 0 is Neutral and position value 1000 (100%) is the end of linear zone. Value of 1022 indicates an error has occurred.

Data Length: 10 bits
Resolution: 0.1 %/bit, 0 offset
Data Range: 0 to 102 % Operational Range: 0.0 to 100.0%
Type: Measured
Supporting information:
PGN 64982

SPN 2662 Joystick 1 Grip X-Axis Position

The position of the joystick grip in the relative motion of travel from the neutral position. Position value of 0 is Neutral and position value 1000 (100%) is the end of linear zone. Value of 1022 indicates an error has occurred.

Data Length: 10 bits
Resolution: 0.1 %/bit, 0 offset
Data Range: 0 to 102 % Operational Range: 0.0 to 100.0%
Type: Measured
Supporting information:
PGN 64983

SPN 2663 Joystick 1 Grip Y-Axis Position

The position of the joystick grip in the relative motion of travel from the neutral position. Position value of 0 is Neutral and position value 1000 (100%) is the end of linear zone. Value of 1022 indicates an error has occurred.

Data Length: 10 bits
Resolution: 0.1 %/bit, 0 offset
Data Range: 0 to 102 % Operational Range: 0.0 to 100.0%
Type: Measured
Supporting information:
PGN 64983

SPN 2664 Joystick 1 Theta-Axis Position

The position of the joystick in the relative motion of travel from the neutral position. Position value of 0 is Neutral and position value 1000 (100%) is the end of linear zone. Value of 1022 indicates an error has occurred.

Data Length: 10 bits
 Resolution: 0.1 %/bit, 0 offset
 Data Range: 0 to 102 % Operational Range: 0.0 to 100.0%
 Type: Measured
 Supporting information:
 PGN 64983

SPN 2665 Joystick 1 X-Axis Lever Right Positive Position Status

Reports when the current joystick position is on the positive travel side (forward, right, clockwise, up) relative to the neutral position for that axis of travel.

00 Not on Positive side of Neutral
 01 On positive side of Neutral
 10 Error Indicator
 11 Not Available

Data Length: 2 bits
 Resolution: 4 states/2 bit, 0 offset
 Data Range: 0 to 3 Operational Range: same as data range
 Type: Measured
 Supporting information:
 PGN 64982

SPN 2666 Joystick 1 Y-Axis Lever Forward Positive Position Status

Reports when the current joystick position is on the positive travel side (forward, right, clockwise, up) relative to the neutral position for that axis of travel.

00 Not on Positive side of Neutral
 01 On positive side of Neutral
 10 Error Indicator
 11 Not Available

Data Length: 2 bits
 Resolution: 4 states/2 bit, 0 offset
 Data Range: 0 to 3 Operational Range: same as data range
 Type: Measured
 Supporting information:
 PGN 64982

SPN 2667 Joystick 1 Grip X-Axis Lever Right Positive Position Status

Reports when the current joystick grip position is on the positive travel side (forward, right, clockwise, up) relative to the neutral position for that axis of travel.

00 Not on Positive side of Neutral
01 On positive side of Neutral
10 Error Indicator
11 Not Available

Data Length: 2 bits
Resolution: 4 states/2 bit, 0 offset
Data Range: 0 to 3 Operational Range: same as data range
Type: Measured
Supporting information:
PGN 64983

SPN 2668 Joystick 1 Grip Y-Axis Lever Forward Positive Position Status

Reports when the current joystick grip position is on the positive travel side (forward, right, clockwise, up) relative to the neutral position for that axis of travel.

00 Not on Positive side of Neutral
01 On positive side of Neutral
10 Error Indicator
11 Not Available

Data Length: 2 bits
Resolution: 4 states/2 bit, 0 offset
Data Range: 0 to 3 Operational Range: same as data range
Type: Measured
Supporting information:
PGN 64983

SPN 2669 Joystick 1 Theta-Axis Clockwise Positive Position Status

Reports when the current joystick position is on the positive travel side (forward, right, clockwise, up) relative to the neutral position for that axis of travel.

00 Not on Positive side of Neutral
01 On positive side of Neutral
10 Error Indicator
11 Not Available

Data Length: 2 bits
Resolution: 4 states/2 bit, 0 offset
Data Range: 0 to 3 Operational Range: same as data range
Type: Measured
Supporting information:
PGN 64983

SPN 2670 Joystick 1 X-Axis Lever Left Negative Position Status

Reports when the current joystick position is on the negative travel side (back, left, counterclockwise, down) relative to the neutral position for that axis of travel.

00 Not on negative side of Neutral
 01 On negative side of Neutral
 10 Error Indicator
 11 Not Available

Data Length: 2 bits
 Resolution: 4 states/2 bit, 0 offset
 Data Range: 0 to 3 Operational Range: same as data range
 Type: Measured
 Supporting information:
 PGN 64982

SPN 2671 Joystick 1 Y-Axis Lever Back Negative Position Status

Reports when the current joystick position is on the negative travel side (back, left, counterclockwise, down) relative to the neutral position for that axis of travel.

00 Not on negative side of Neutral
 01 On negative side of Neutral
 10 Error Indicator
 11 Not Available

Data Length: 2 bits
 Resolution: 4 states/2 bit, 0 offset
 Data Range: 0 to 3 Operational Range: same as data range
 Type: Measured
 Supporting information:
 PGN 64982

SPN 2672 Joystick 1 Grip X-Axis Lever Left Negative Position Status

Reports when the current joystick grip position is on the negative travel side (back, left, counterclockwise, down) relative to the neutral position for that axis of travel.

00 Not on negative side of Neutral
 01 On negative side of Neutral
 10 Error Indicator
 11 Not Available

Data Length: 2 bits
 Resolution: 4 states/2 bit, 0 offset
 Data Range: 0 to 3 Operational Range: same as data range
 Type: Measured
 Supporting information:
 PGN 64983

SPN 2673 Joystick 1 Grip Y-Axis Lever Back Negative Position Status

Reports when the current joystick grip position is on the negative travel side (back, left, counterclockwise, down) relative to the neutral position for that axis of travel.

00 Not on negative side of Neutral
01 On negative side of Neutral
10 Error Indicator
11 Not Available

Data Length: 2 bits
Resolution: 4 states/2 bit, 0 offset
Data Range: 0 to 3 Operational Range: same as data range
Type: Measured
Supporting information:
PGN 64983

SPN 2674 Joystick 1 Theta-Axis Counter Clockwise Negative Position Status

Reports when the current joystick position is on the negative travel side (back, left, counterclockwise, down) relative to the neutral position for that axis of travel.

00 Not on negative side of Neutral
01 On negative side of Neutral
10 Error Indicator
11 Not Available

Data Length: 2 bits
Resolution: 4 states/2 bit, 0 offset
Data Range: 0 to 3 Operational Range: same as data range
Type: Measured
Supporting information:
PGN 64983

SPN 2675 Joystick 1 X-Axis Neutral Position Status

Reports when the current joystick position is in the neutral position for that axis of travel. The neutral position measurement must be determined from some mechanism other than the axis position measurement device.

00 Not in Neutral Position
01 In Neutral Position
10 Error Indicator
11 Not Available

Data Length: 2 bits
Resolution: 4 states/2 bit, 0 offset
Data Range: 0 to 3 Operational Range: same as data range
Type: Measured
Supporting information:
PGN 64982

SPN 2676 Joystick 1 Y-Axis Neutral Position Status

Reports when the current joystick position is in the neutral position for that axis of travel. The neutral position measurement must be determined from some mechanism other than the axis position measurement device.

00 Not in Neutral Position
01 In Neutral Position
10 Error Indicator
11 Not Available

Data Length: 2 bits
Resolution: 4 states/2 bit, 0 offset
Data Range: 0 to 3 Operational Range: same as data range
Type: Measured
Supporting information:
PGN 64982

SPN 2677 Joystick 1 Grip X-Axis Neutral Position Status

Reports when the current joystick grip position is in the neutral position for that axis of travel. The neutral position measurement must be determined from some mechanism other than the axis position measurement device.

00 Not in Neutral Position
01 In Neutral Position
10 Error Indicator
11 Not Available

Data Length: 2 bits
Resolution: 4 states/2 bit, 0 offset
Data Range: 0 to 3 Operational Range: same as data range
Type: Measured
Supporting information:
PGN 64983

SPN 2678 Joystick 1 Grip Y-Axis Neutral Position Status

Reports when the current joystick grip position is in the neutral position for that axis of travel. The neutral position measurement must be determined from some mechanism other than the axis position measurement device.

00 Not in Neutral Position
01 In Neutral Position
10 Error Indicator
11 Not Available

Data Length: 2 bits
Resolution: 4 states/2 bit, 0 offset
Data Range: 0 to 3 Operational Range: same as data range
Type: Measured
Supporting information:
PGN 64983

SPN 2679 Joystick 1 Theta-Axis Neutral Position Status

Reports when the current joystick position is in the neutral position for that axis of travel. The neutral position measurement must be determined from some mechanism other than the axis position measurement device.

00 Not in Neutral Position
01 In Neutral Position
10 Error Indicator
11 Not Available

Data Length: 2 bits
Resolution: 4 states/2 bit, 0 offset
Data Range: 0 to 3 Operational Range: same as data range
Type: Measured
Supporting information:
PGN 64983

SPN 2680 Joystick 1 X-Axis Detent Position Status

Reports when the current joystick position is in the detent position for that axis of travel.

00 Not in the Detent Position
01 In the Detent Position
10 Error Indicator
11 Not Available

Data Length: 2 bits
Resolution: 4 states/2 bit, 0 offset
Data Range: 0 to 3 Operational Range: same as data range
Type: Measured
Supporting information:
PGN 64982

SPN 2681 Joystick 1 Y-Axis Detent Position Status

Reports when the current joystick position is in the detent position for that axis of travel.

00 Not in the Detent Position
01 In the Detent Position
10 Error Indicator
11 Not Available

Data Length: 2 bits
Resolution: 4 states/2 bit, 0 offset
Data Range: 0 to 3 Operational Range: same as data range
Type: Measured
Supporting information:
PGN 64982

SPN 2682 Joystick 1 Grip X-Axis Detent Position Status

Reports when the current joystick grip position is in the detent position for that axis of travel.

00 Not in the Detent Position
01 In the Detent Position
10 Error Indicator
11 Not Available

Data Length: 2 bits
Resolution: 4 states/2 bit, 0 offset
Data Range: 0 to 3 Operational Range: same as data range
Type: Measured
Supporting information:
PGN 64983

SPN 2683 Joystick 1 Grip Y-Axis Detent Position Status

Reports when the current joystick grip position is in the detent position for that axis of travel.

00 Not in the Detent Position
01 In the Detent Position
10 Error Indicator
11 Not Available

Data Length: 2 bits
Resolution: 4 states/2 bit, 0 offset
Data Range: 0 to 3 Operational Range: same as data range
Type: Measured
Supporting information:
PGN 64983

SPN 2684 Joystick 1 Theta-Axis Detent Position Status

Reports when the current joystick position is in the detent position for that axis of travel.

00 Not in the Detent Position
01 In the Detent Position
10 Error Indicator
11 Not Available

Data Length: 2 bits
Resolution: 4 states/2 bit, 0 offset
Data Range: 0 to 3 Operational Range: same as data range
Type: Measured
Supporting information:
PGN 64983

SPN 2685 Joystick 1 Button 1 Pressed Status

Reports when the joystick button has been pressed.

00 Button not pressed
01 Button pressed
10 Error Indicator
11 Not Available

Data Length: 2 bits
Resolution: 4 states/2 bit, 0 offset
Data Range: 0 to 3 Operational Range: same as data range
Type: Measured
Supporting information:
PGN 64982

SPN 2686 Joystick 1 Button 2 Pressed Status

Reports when the joystick button has been pressed.

00 Button not pressed
01 Button pressed
10 Error Indicator
11 Not Available

Data Length: 2 bits
Resolution: 4 states/2 bit, 0 offset
Data Range: 0 to 3 Operational Range: same as data range
Type: Measured
Supporting information:
PGN 64982

SPN 2687 Joystick 1 Button 3 Pressed Status

Reports when the joystick button has been pressed.

00 Button not pressed
01 Button pressed
10 Error Indicator
11 Not Available

Data Length: 2 bits
Resolution: 4 states/2 bit, 0 offset
Data Range: 0 to 3 Operational Range: same as data range
Type: Measured
Supporting information:
PGN 64982

SPN 2688 Joystick 1 Button 4 Pressed Status

Reports when the joystick button has been pressed.

00 Button not pressed
01 Button pressed
10 Error Indicator
11 Not Available

Data Length: 2 bits
Resolution: 4 states/2 bit, 0 offset
Data Range: 0 to 3 Operational Range: same as data range
Type: Measured
Supporting information:
PGN 64982

SPN 2689 Joystick 1 Button 5 Pressed Status

Reports when the joystick button has been pressed.

00 Button not pressed
01 Button pressed
10 Error Indicator
11 Not Available

Data Length: 2 bits
Resolution: 4 states/2 bit, 0 offset
Data Range: 0 to 3 Operational Range: same as data range
Type: Measured
Supporting information:
PGN 64982

SPN 2690 Joystick 1 Button 6 Pressed Status

Reports when the joystick button has been pressed.

00 Button not pressed
01 Button pressed
10 Error Indicator
11 Not Available

Data Length: 2 bits
Resolution: 4 states/2 bit, 0 offset
Data Range: 0 to 3 Operational Range: same as data range
Type: Measured
Supporting information:
PGN 64982

SPN 2691 Joystick 1 Button 7 Pressed Status

Reports when the joystick button has been pressed.

00 Button not pressed
01 Button pressed
10 Error Indicator
11 Not Available

Data Length: 2 bits
Resolution: 4 states/2 bit, 0 offset
Data Range: 0 to 3 Operational Range: same as data range
Type: Measured
Supporting information:
PGN 64982

SPN 2692 Joystick 1 Button 8 Pressed Status

Reports when the joystick button has been pressed.

00 Button not pressed
01 Button pressed
10 Error Indicator
11 Not Available

Data Length: 2 bits
Resolution: 4 states/2 bit, 0 offset
Data Range: 0 to 3 Operational Range: same as data range
Type: Measured
Supporting information:
PGN 64982

SPN 2693 Joystick 1 Button 9 Pressed Status

Reports when the joystick button has been pressed.

00 Button not pressed
01 Button pressed
10 Error Indicator
11 Not Available

Data Length: 2 bits
Resolution: 4 states/2 bit, 0 offset
Data Range: 0 to 3 Operational Range: same as data range
Type: Measured
Supporting information:
PGN 64982

SPN 2694 Joystick 1 Button 10 Pressed Status

Reports when the joystick button has been pressed.

00 Button not pressed
01 Button pressed
10 Error Indicator
11 Not Available

Data Length: 2 bits
Resolution: 4 states/2 bit, 0 offset
Data Range: 0 to 3 Operational Range: same as data range
Type: Measured
Supporting information:
PGN 64982

SPN 2695 Joystick 1 Button 11 Pressed Status

Reports when the joystick button has been pressed.

00 Button not pressed
01 Button pressed
10 Error Indicator
11 Not Available

Data Length: 2 bits
Resolution: 4 states/2 bit, 0 offset
Data Range: 0 to 3 Operational Range: same as data range
Type: Measured
Supporting information:
PGN 64982

SPN 2696 Joystick 1 Button 12 Pressed Status

Reports when the joystick button has been pressed.

00 Button not pressed
01 Button pressed
10 Error Indicator
11 Not Available

Data Length: 2 bits
Resolution: 4 states/2 bit, 0 offset
Data Range: 0 to 3 Operational Range: same as data range
Type: Measured
Supporting information:
PGN 64982

SPN 2697 Joystick 2 X-Axis Position

The position of the joystick in the relative motion of travel from the neutral position. Position value of 0 is Neutral and position value 1000 (100%) is the end of linear zone. Value of 1022 indicates an error has occurred.

Data Length: 10 bits
Resolution: 0.1 %/bit, 0 offset
Data Range: 0 to 102 % Operational Range: 0.0 to 100.0%
Type: Measured
Supporting information:
PGN 64984

SPN 2698 Joystick 2 Y-Axis Position

The position of the joystick in the relative motion of travel from the neutral position. Position value of 0 is Neutral and position value 1000 (100%) is the end of linear zone. Value of 1022 indicates an error has occurred.

Data Length: 10 bits
Resolution: 0.1 %/bit, 0 offset
Data Range: 0 to 102 % Operational Range: 0.0 to 100.0%
Type: Measured
Supporting information:
PGN 64984

SPN 2699 Joystick 2 Grip X-Axis Position

The position of the joystick grip in the relative motion of travel from the neutral position. Position value of 0 is Neutral and position value 1000 (100%) is the end of linear zone. Value of 1022 indicates an error has occurred.

Data Length: 10 bits
Resolution: 0.1 %/bit, 0 offset
Data Range: 0 to 102 % Operational Range: 0.0 to 100.0%
Type: Measured
Supporting information:
PGN 64985

SPN 2700 Joystick 2 Grip Y-Axis Position

The position of the joystick grip in the relative motion of travel from the neutral position. Position value of 0 is Neutral and position value 1000 (100%) is the end of linear zone. Value of 1022 indicates an error has occurred.

Data Length: 10 bits
Resolution: 0.1 %/bit, 0 offset
Data Range: 0 to 102 % Operational Range: 0.0 to 100.0%
Type: Measured
Supporting information:
PGN 64985

SPN 2701 Joystick 2 Theta-Axis Position

The position of the joystick in the relative motion of travel from the neutral position. Position value of 0 is Neutral and position value 1000 (100%) is the end of linear zone. Value of 1022 indicates an error has occurred.

Data Length: 10 bits
 Resolution: 0.1 %/bit, 0 offset
 Data Range: 0 to 102 % Operational Range: 0.0 to 100.0%
 Type: Measured
 Supporting information:
 PGN 64985

SPN 2702 Joystick 2 X-Axis Lever Right Positive Position Status

Reports when the current joystick position is on the positive travel side (forward, right, clockwise, up) relative to the neutral position for that axis of travel.

00 Not on Positive side of Neutral
 01 On positive side of Neutral
 10 Error Indicator
 11 Not Available

Data Length: 2 bits
 Resolution: 4 states/2 bit, 0 offset
 Data Range: 0 to 3 Operational Range: same as data range
 Type: Measured
 Supporting information:
 PGN 64984

SPN 2703 Joystick 2 Y-Axis Lever Forward Positive Position Status

Reports when the current joystick position is on the positive travel side (forward, right, clockwise, up) relative to the neutral position for that axis of travel.

00 Not on Positive side of Neutral
 01 On positive side of Neutral
 10 Error Indicator
 11 Not Available

Data Length: 2 bits
 Resolution: 4 states/2 bit, 0 offset
 Data Range: 0 to 3 Operational Range: same as data range
 Type: Measured
 Supporting information:
 PGN 64984

SPN 2704 Joystick 2 Grip X-Axis Lever Right Positive Position Status

Reports when the current joystick grip position is on the positive travel side (forward, right, clockwise, up) relative to the neutral position for that axis of travel.

00 Not on Positive side of Neutral
01 On positive side of Neutral
10 Error Indicator
11 Not Available

Data Length: 2 bits
Resolution: 4 states/2 bit, 0 offset
Data Range: 0 to 3 Operational Range: same as data range
Type: Measured
Supporting information:
PGN 64985

SPN 2705 Joystick 2 Grip Y-Axis Lever Forward Positive Position Status

Reports when the current joystick grip position is on the positive travel side (forward, right, clockwise, up) relative to the neutral position for that axis of travel.

00 Not on Positive side of Neutral
01 On positive side of Neutral
10 Error Indicator
11 Not Available

Data Length: 2 bits
Resolution: 4 states/2 bit, 0 offset
Data Range: 0 to 3 Operational Range: same as data range
Type: Measured
Supporting information:
PGN 64985

SPN 2706 Joystick 2 Theta-Axis Clockwise Positive Position Status

Reports when the current joystick position is on the positive travel side (forward, right, clockwise, up) relative to the neutral position for that axis of travel.

00 Not on Positive side of Neutral
01 On positive side of Neutral
10 Error Indicator
11 Not Available

Data Length: 2 bits
Resolution: 4 states/2 bit, 0 offset
Data Range: 0 to 3 Operational Range: same as data range
Type: Measured
Supporting information:
PGN 64985

SPN 2707 Joystick 2 X-Axis Lever Left Negative Position Status

Reports when the current joystick position is on the negative travel side (back, left, counterclockwise, down) relative to the neutral position for that axis of travel.

00 Not on negative side of Neutral
01 On negative side of Neutral
10 Error Indicator
11 Not Available

Data Length: 2 bits
Resolution: 4 states/2 bit, 0 offset
Data Range: 0 to 3 Operational Range: same as data range
Type: Measured
Supporting information:
PGN 64984

SPN 2708 Joystick 2 Y-Axis Lever Back Negative Position Status

Reports when the current joystick position is on the negative travel side (back, left, counterclockwise, down) relative to the neutral position for that axis of travel.

00 Not on negative side of Neutral
01 On negative side of Neutral
10 Error Indicator
11 Not Available

Data Length: 2 bits
Resolution: 4 states/2 bit, 0 offset
Data Range: 0 to 3 Operational Range: same as data range
Type: Measured
Supporting information:
PGN 64984

SPN 2709 Joystick 2 Grip X-Axis Lever Left Negative Position Status

Reports when the current joystick grip position is on the negative travel side (back, left, counterclockwise, down) relative to the neutral position for that axis of travel.

00 Not on negative side of Neutral
01 On negative side of Neutral
10 Error Indicator
11 Not Available

Data Length: 2 bits
Resolution: 4 states/2 bit, 0 offset
Data Range: 0 to 3 Operational Range: same as data range
Type: Measured
Supporting information:
PGN 64985

SPN 2710 Joystick 2 Grip Y-Axis Lever Back Negative Position Status

Reports when the current joystick grip position is on the negative travel side (back, left, counterclockwise, down) relative to the neutral position for that axis of travel.

00 Not on negative side of Neutral
01 On negative side of Neutral
10 Error Indicator
11 Not Available

Data Length: 2 bits
Resolution: 4 states/2 bit, 0 offset
Data Range: 0 to 3 Operational Range: same as data range
Type: Measured
Supporting information:
PGN 64985

SPN 2711 Joystick 2 Theta-Axis Counter Clockwise Negative Position Status

Reports when the current joystick position is on the negative travel side (back, left, counterclockwise, down) relative to the neutral position for that axis of travel.

00 Not on negative side of Neutral
01 On negative side of Neutral
10 Error Indicator
11 Not Available

Data Length: 2 bits
Resolution: 4 states/2 bit, 0 offset
Data Range: 0 to 3 Operational Range: same as data range
Type: Measured
Supporting information:
PGN 64985

SPN 2712 Joystick 2 X-Axis Neutral Position Status

Reports when the current joystick position is in the neutral position for that axis of travel. The neutral position measurement must be determined from some mechanism other than the axis position measurement device.

00 Not in Neutral Position
01 In Neutral Position
10 Error Indicator
11 Not Available

Data Length: 2 bits
Resolution: 4 states/2 bit, 0 offset
Data Range: 0 to 3 Operational Range: same as data range
Type: Measured
Supporting information:
PGN 64984

SPN 2713 Joystick 2 Y-Axis Neutral Position Status

Reports when the current joystick position is in the neutral position for that axis of travel. The neutral position measurement must be determined from some mechanism other than the axis position measurement device.

00 Not in Neutral Position
01 In Neutral Position
10 Error Indicator
11 Not Available

Data Length: 2 bits
Resolution: 4 states/2 bit, 0 offset
Data Range: 0 to 3 Operational Range: same as data range
Type: Measured
Supporting information:
PGN 64984

SPN 2714 Joystick 2 Grip X-Axis Neutral Position Status

Reports when the current joystick grip position is in the neutral position for that axis of travel. The neutral position measurement must be determined from some mechanism other than the axis position measurement device.

00 Not on negative side of Neutral
01 On negative side of Neutral
10 Error Indicator
11 Not Available

Data Length: 2 bits
Resolution: 4 states/2 bit, 0 offset
Data Range: 0 to 3 Operational Range: same as data range
Type: Measured
Supporting information:
PGN 64985

SPN 2715 Joystick 2 Grip Y-Axis Neutral Position Status

Reports when the current joystick grip position is in the neutral position for that axis of travel. The neutral position measurement must be determined from some mechanism other than the axis position measurement device.

00 Not in Neutral Position
01 In Neutral Position
10 Error Indicator
11 Not Available

Data Length: 2 bits
Resolution: 4 states/2 bit, 0 offset
Data Range: 0 to 3 Operational Range: same as data range
Type: Measured
Supporting information:
PGN 64985

SPN 2716 Joystick 2 Theta-Axis Neutral Position Status

Reports when the current joystick position is in the neutral position for that axis of travel. The neutral position measurement must be determined from some mechanism other than the axis position measurement device.

00 Not in Neutral Position
01 In Neutral Position
10 Error Indicator
11 Not Available

Data Length: 2 bits
Resolution: 4 states/2 bit, 0 offset
Data Range: 0 to 3 Operational Range: same as data range
Type: Measured
Supporting information:
PGN 64985

SPN 2717 Joystick 2 X-Axis Detent Position Status

Reports when the current joystick position is in the detent position for that axis of travel.

00 Not in the Detent Position
01 In the Detent Position
10 Error Indicator
11 Not Available

Data Length: 2 bits
Resolution: 4 states/2 bit, 0 offset
Data Range: 0 to 3 Operational Range: same as data range
Type: Measured
Supporting information:
PGN 64984

SPN 2718 Joystick 2 Y-Axis Detent Position Status

Reports when the current joystick position is in the detent position for that axis of travel.

00 Not in the Detent Position
01 In the Detent Position
10 Error Indicator
11 Not Available

Data Length: 2 bits
Resolution: 4 states/2 bit, 0 offset
Data Range: 0 to 3 Operational Range: same as data range
Type: Measured
Supporting information:
PGN 64984

SPN 2719 Joystick 2 Grip X-Axis Detent Position Status

Reports when the current joystick grip position is in the detent position for that axis of travel.

00 Not in the Detent Position
01 In the Detent Position
10 Error Indicator
11 Not Available

Data Length: 2 bits
Resolution: 4 states/2 bit, 0 offset
Data Range: 0 to 3 Operational Range: same as data range
Type: Measured
Supporting information:
PGN 64985

SPN 2720 Joystick 2 Grip Y-Axis Detent Position Status

Reports when the current joystick grip position is in the detent position for that axis of travel.

00 Not in the Detent Position
01 In the Detent Position
10 Error Indicator
11 Not Available

Data Length: 2 bits
Resolution: 4 states/2 bit, 0 offset
Data Range: 0 to 3 Operational Range: same as data range
Type: Measured
Supporting information:
PGN 64985

SPN 2721 Joystick 2 Theta-Axis Detent Position Status

Reports when the current joystick position is in the detent position for that axis of travel.

00 Not in the Detent Position
01 In the Detent Position
10 Error Indicator
11 Not Available

Data Length: 2 bits
Resolution: 4 states/2 bit, 0 offset
Data Range: 0 to 3 Operational Range: same as data range
Type: Measured
Supporting information:
PGN 64985

SPN 2722 Joystick 2 Button 1 Pressed Status

Reports when the joystick button has been pressed.

00 Button not pressed
01 Button pressed
10 Error Indicator
11 Not Available

Data Length: 2 bits
Resolution: 4 states/2 bit, 0 offset
Data Range: 0 to 3 Operational Range: same as data range
Type: Measured
Supporting information:
PGN 64984

SPN 2723 Joystick 2 Button 2 Pressed Status

Reports when the joystick button has been pressed.

00 Button not pressed
01 Button pressed
10 Error Indicator
11 Not Available

Data Length: 2 bits
Resolution: 4 states/2 bit, 0 offset
Data Range: 0 to 3 Operational Range: same as data range
Type: Measured
Supporting information:
PGN 64984

SPN 2724 Joystick 2 Button 3 Pressed Status

Reports when the joystick button has been pressed.

00 Button not pressed
01 Button pressed
10 Error Indicator
11 Not Available

Data Length: 2 bits
Resolution: 4 states/2 bit, 0 offset
Data Range: 0 to 3 Operational Range: same as data range
Type: Measured
Supporting information:
PGN 64984

SPN 2725 Joystick 2 Button 4 Pressed Status

Reports when the joystick button has been pressed.

00 Button not pressed
01 Button pressed
10 Error Indicator
11 Not Available

Data Length: 2 bits
Resolution: 4 states/2 bit, 0 offset
Data Range: 0 to 3 Operational Range: same as data range
Type: Measured
Supporting information:
PGN 64984

SPN 2726 Joystick 2 Button 5 Pressed Status

Reports when the joystick button has been pressed.

00 Button not pressed
01 Button pressed
10 Error Indicator
11 Not Available

Data Length: 2 bits
Resolution: 4 states/2 bit, 0 offset
Data Range: 0 to 3 Operational Range: same as data range
Type: Measured
Supporting information:
PGN 64984

SPN 2727 Joystick 2 Button 6 Pressed Status

Reports when the joystick button has been pressed.

00 Button not pressed
01 Button pressed
10 Error Indicator
11 Not Available

Data Length: 2 bits
Resolution: 4 states/2 bit, 0 offset
Data Range: 0 to 3 Operational Range: same as data range
Type: Measured
Supporting information:
PGN 64984

SPN 2728 Joystick 2 Button 7 Pressed Status

Reports when the joystick button has been pressed.

00 Button not pressed
01 Button pressed
10 Error Indicator
11 Not Available

Data Length: 2 bits
Resolution: 4 states/2 bit, 0 offset
Data Range: 0 to 3 Operational Range: same as data range
Type: Measured
Supporting information:
PGN 64984

SPN 2729 Joystick 2 Button 8 Pressed Status

Reports when the joystick button has been pressed.

00 Button not pressed
01 Button pressed
10 Error Indicator
11 Not Available

Data Length: 2 bits
Resolution: 4 states/2 bit, 0 offset
Data Range: 0 to 3 Operational Range: same as data range
Type: Measured
Supporting information:
PGN 64984

SPN 2730 Joystick 2 Button 9 Pressed Status

Reports when the joystick button has been pressed.

00 Button not pressed
01 Button pressed
10 Error Indicator
11 Not Available

Data Length: 2 bits
Resolution: 4 states/2 bit, 0 offset
Data Range: 0 to 3 Operational Range: same as data range
Type: Measured
Supporting information:
PGN 64984

SPN 2731 Joystick 2 Button 10 Pressed Status

Reports when the joystick button has been pressed.

00 Button not pressed
01 Button pressed
10 Error Indicator
11 Not Available

Data Length: 2 bits
Resolution: 4 states/2 bit, 0 offset
Data Range: 0 to 3 Operational Range: same as data range
Type: Measured
Supporting information:
PGN 64984

SPN 2732 Joystick 2 Button 11 Pressed Status

Reports when the joystick button has been pressed.

00 Button not pressed
01 Button pressed
10 Error Indicator
11 Not Available

Data Length: 2 bits
Resolution: 4 states/2 bit, 0 offset
Data Range: 0 to 3 Operational Range: same as data range
Type: Measured
Supporting information:
PGN 64984

SPN 2733 Joystick 2 Button 12 Pressed Status

Reports when the joystick button has been pressed.

00 Button not pressed
01 Button pressed
10 Error Indicator
11 Not Available

Data Length: 2 bits
Resolution: 4 states/2 bit, 0 offset
Data Range: 0 to 3 Operational Range: same as data range
Type: Measured
Supporting information:
PGN 64984

SPN 2734 Joystick 3 X-Axis Position

The position of the joystick in the relative motion of travel from the neutral position. Position value of 0 is Neutral and position value 1000 (100%) is the end of linear zone. Value of 1022 indicates an error has occurred.

Data Length: 10 bits
Resolution: 0.1 %/bit, 0 offset
Data Range: 0 to 102 % Operational Range: 0.0 to 100.0%
Type: Measured
Supporting information:
PGN 64986

SPN 2735 Joystick 3 Y-Axis Position

The position of the joystick in the relative motion of travel from the neutral position. Position value of 0 is Neutral and position value 1000 (100%) is the end of linear zone. Value of 1022 indicates an error has occurred.

Data Length: 10 bits
Resolution: 0.1 %/bit, 0 offset
Data Range: 0 to 102 % Operational Range: 0.0 to 100.0%
Type: Measured
Supporting information:
PGN 64986

SPN 2736 Joystick 3 Grip X-Axis Position

The position of the joystick grip in the relative motion of travel from the neutral position. Position value of 0 is Neutral and position value 1000 (100%) is the end of linear zone. Value of 1022 indicates an error has occurred.

Data Length: 10 bits
Resolution: 0.1 %/bit, 0 offset
Data Range: 0 to 102 % Operational Range: 0.0 to 100.0%
Type: Measured
Supporting information:
PGN 64987

SPN 2737 Joystick 3 Grip Y-Axis Position

The position of the joystick grip in the relative motion of travel from the neutral position. Position value of 0 is Neutral and position value 1000 (100%) is the end of linear zone. Value of 1022 indicates an error has occurred.

Data Length: 10 bits
Resolution: 0.1 %/bit, 0 offset
Data Range: 0 to 102 % Operational Range: 0.0 to 100.0%
Type: Measured
Supporting information:
PGN 64987

SPN 2738 Joystick 3 Theta-Axis Position

The position of the joystick in the relative motion of travel from the neutral position. Position value of 0 is Neutral and position value 1000 (100%) is the end of linear zone. Value of 1022 indicates an error has occurred.

Data Length: 10 bits
Resolution: 0.1 %/bit, 0 offset
Data Range: 0 to 102 % Operational Range: 0.0 to 100.0%
Type: Measured
Supporting information:
PGN 64987

SPN 2739 Joystick 3 X-Axis Lever Right Positive Position Status

Reports when the current joystick position is on the positive travel side (forward, right, clockwise, up) relative to the neutral position for that axis of travel.

00 Not on Positive side of Neutral
01 On positive side of Neutral
10 Error Indicator
11 Not Available

Data Length: 2 bits
Resolution: 4 states/2 bit, 0 offset
Data Range: 0 to 3 Operational Range: same as data range
Type: Measured
Supporting information:
PGN 64986

SPN 2740 Joystick 3 Y-Axis Lever Forward Positive Position Status

Reports when the current joystick position is on the positive travel side (forward, right, clockwise, up) relative to the neutral position for that axis of travel.

00 Not on Positive side of Neutral
01 On positive side of Neutral
10 Error Indicator
11 Not Available

Data Length: 2 bits
Resolution: 4 states/2 bit, 0 offset
Data Range: 0 to 3 Operational Range: same as data range
Type: Measured
Supporting information:
PGN 64986

SPN 2741 Joystick 3 Grip X-Axis Lever Right Positive Position Status

Reports when the current joystick grip position is on the positive travel side (forward, right, clockwise, up) relative to the neutral position for that axis of travel.

00 Not on Positive side of Neutral
01 On positive side of Neutral
10 Error Indicator
11 Not Available

Data Length: 2 bits
Resolution: 4 states/2 bit, 0 offset
Data Range: 0 to 3 Operational Range: same as data range
Type: Measured
Supporting information:
PGN 64987

SPN 2742 Joystick 3 Grip Y-Axis Lever Forward Positive Position Status

Reports when the current joystick grip position is on the positive travel side (forward, right, clockwise, up) relative to the neutral position for that axis of travel.

00 Not on Positive side of Neutral
01 On positive side of Neutral
10 Error Indicator
11 Not Available

Data Length: 2 bits
Resolution: 4 states/2 bit, 0 offset
Data Range: 0 to 3 Operational Range: same as data range
Type: Measured
Supporting information:
PGN 64987

SPN 2743 Joystick 3 Theta-Axis Clockwise Positive Position Status

Reports when the current joystick position is on the positive travel side (forward, right, clockwise, up) relative to the neutral position for that axis of travel.

00 Not on Positive side of Neutral
01 On positive side of Neutral
10 Error Indicator
11 Not Available

Data Length: 2 bits
Resolution: 4 states/2 bit, 0 offset
Data Range: 0 to 3 Operational Range: same as data range
Type: Measured
Supporting information:
PGN 64987

SPN 2744 Joystick 3 X-Axis Lever Left Negative Position Status

Reports when the current joystick position is on the negative travel side (back, left, counterclockwise, down) relative to the neutral position for that axis of travel.

00 Not on negative side of Neutral
01 On negative side of Neutral
10 Error Indicator
11 Not Available

Data Length: 2 bits
Resolution: 4 states/2 bit, 0 offset
Data Range: 0 to 3 Operational Range: same as data range
Type: Measured
Supporting information:
PGN 64986

SPN 2745 Joystick 3 Y-Axis Lever Back Negative Position Status

Reports when the current joystick position is on the negative travel side (back, left, counterclockwise, down) relative to the neutral position for that axis of travel.

00 Not on negative side of Neutral
01 On negative side of Neutral
10 Error Indicator
11 Not Available

Data Length: 2 bits
Resolution: 4 states/2 bit, 0 offset
Data Range: 0 to 3 Operational Range: same as data range
Type: Measured
Supporting information:
PGN 64986

SPN 2746 Joystick 3 Grip X-Axis Lever Left Negative Position Status

Reports when the current joystick grip position is on the negative travel side (back, left, counterclockwise, down) relative to the neutral position for that axis of travel.

00 Not on negative side of Neutral
01 On negative side of Neutral
10 Error Indicator
11 Not Available

Data Length: 2 bits
Resolution: 4 states/2 bit, 0 offset
Data Range: 0 to 3 Operational Range: same as data range
Type: Measured
Supporting information:
PGN 64987

SPN 2747 Joystick 3 Grip Y-Axis Lever Back Negative Position Status

Reports when the current joystick grip position is on the negative travel side (back, left, counterclockwise, down) relative to the neutral position for that axis of travel.

00 Not on negative side of Neutral
01 On negative side of Neutral
10 Error Indicator
11 Not Available

Data Length: 2 bits
Resolution: 4 states/2 bit, 0 offset
Data Range: 0 to 3 Operational Range: same as data range
Type: Measured
Supporting information:
PGN 64987

SPN 2748 Joystick 3 Theta-Axis Counter Clockwise Negative Position Status

Reports when the current joystick position is on the negative travel side (back, left, counterclockwise, down) relative to the neutral position for that axis of travel.

00 Not on negative side of Neutral
01 On negative side of Neutral
10 Error Indicator
11 Not Available

Data Length: 2 bits
Resolution: 4 states/2 bit, 0 offset
Data Range: 0 to 3 Operational Range: same as data range
Type: Measured
Supporting information:
PGN 64987

SPN 2749 Joystick 3 X-Axis Neutral Position Status

Reports when the current joystick position is in the neutral position for that axis of travel. The neutral position measurement must be determined from some mechanism other than the axis position measurement device.

00 Not in Neutral Position
01 In Neutral Position
10 Error Indicator
11 Not Available

Data Length: 2 bits
Resolution: 4 states/2 bit, 0 offset
Data Range: 0 to 3 Operational Range: same as data range
Type: Measured
Supporting information:
PGN 64986

SPN 2750 Joystick 3 Y-Axis Neutral Position Status

Reports when the current joystick position is in the neutral position for that axis of travel. The neutral position measurement must be determined from some mechanism other than the axis position measurement device.

00 Not in Neutral Position
01 In Neutral Position
10 Error Indicator
11 Not Available

Data Length: 2 bits
Resolution: 4 states/2 bit, 0 offset
Data Range: 0 to 3 Operational Range: same as data range
Type: Measured
Supporting information:
PGN 64986

SPN 2751 Joystick 3 Grip X-Axis Neutral Position Status

Reports when the current joystick grip position is in the neutral position for that axis of travel. The neutral position measurement must be determined from some mechanism other than the axis position measurement device.

00 Not on negative side of Neutral
01 On negative side of Neutral
10 Error Indicator
11 Not Available

Data Length: 2 bits
Resolution: 4 states/2 bit, 0 offset
Data Range: 0 to 3 Operational Range: same as data range
Type: Measured
Supporting information:
PGN 64987

SPN 2752 Joystick 3 Grip Y-Axis Neutral Position Status

Reports when the current joystick grip position is in the neutral position for that axis of travel. The neutral position measurement must be determined from some mechanism other than the axis position measurement device.

00 Not in Neutral Position
01 In Neutral Position
10 Error Indicator
11 Not Available

Data Length: 2 bits
Resolution: 4 states/2 bit, 0 offset
Data Range: 0 to 3 Operational Range: same as data range
Type: Measured
Supporting information:
PGN 64987

SPN 2753 Joystick 3 Theta-Axis Neutral Position Status

Reports when the current joystick position is in the neutral position for that axis of travel. The neutral position measurement must be determined from some mechanism other than the axis position measurement device.

00 Not in Neutral Position
01 In Neutral Position
10 Error Indicator
11 Not Available

Data Length: 2 bits
Resolution: 4 states/2 bit, 0 offset
Data Range: 0 to 3 Operational Range: same as data range
Type: Measured
Supporting information:
PGN 64987

SPN 2754 Joystick 3 X-Axis Detent Position Status

Reports when the current joystick position is in the detent position for that axis of travel.

00 Not in the Detent Position
01 In the Detent Position
10 Error Indicator
11 Not Available

Data Length: 2 bits
Resolution: 4 states/2 bit, 0 offset
Data Range: 0 to 3 Operational Range: same as data range
Type: Measured
Supporting information:
PGN 64986

SPN 2755 Joystick 3 Y-Axis Detent Position Status

Reports when the current joystick position is in the detent position for that axis of travel.

00 Not in the Detent Position
01 In the Detent Position
10 Error Indicator
11 Not Available

Data Length: 2 bits
Resolution: 4 states/2 bit, 0 offset
Data Range: 0 to 3 Operational Range: same as data range
Type: Measured
Supporting information:
PGN 64986

SPN 2756 Joystick 3 Grip X-Axis Detent Position Status

Reports when the current joystick grip position is in the detent position for that axis of travel.

00 Not in the Detent Position
01 In the Detent Position
10 Error Indicator
11 Not Available

Data Length: 2 bits
Resolution: 4 states/2 bit, 0 offset
Data Range: 0 to 3 Operational Range: same as data range
Type: Measured
Supporting information:
PGN 64987

SPN 2757 Joystick 3 Grip Y-Axis Detent Position Status

Reports when the current joystick grip position is in the detent position for that axis of travel.

00 Not in the Detent Position
01 In the Detent Position
10 Error Indicator
11 Not Available

Data Length: 2 bits
Resolution: 4 states/2 bit, 0 offset
Data Range: 0 to 3 Operational Range: same as data range
Type: Measured
Supporting information:
PGN 64987

SPN 2758 Joystick 3 Theta-Axis Detent Position Status

Reports when the current joystick position is in the detent position for that axis of travel.

00 Not in the Detent Position
01 In the Detent Position
10 Error Indicator
11 Not Available

Data Length: 2 bits
Resolution: 4 states/2 bit, 0 offset
Data Range: 0 to 3 Operational Range: same as data range
Type: Measured
Supporting information:
PGN 64987

SPN 2759 Joystick 3 Button 1 Pressed Status

Reports when the joystick button has been pressed.

00 Button not pressed
01 Button pressed
10 Error Indicator
11 Not Available

Data Length: 2 bits
Resolution: 4 states/2 bit, 0 offset
Data Range: 0 to 3 Operational Range: same as data range
Type: Measured
Supporting information:
PGN 64986

SPN 2760 Joystick 3 Button 2 Pressed Status

Reports when the joystick button has been pressed.

00 Button not pressed
01 Button pressed
10 Error Indicator
11 Not Available

Data Length: 2 bits
Resolution: 4 states/2 bit, 0 offset
Data Range: 0 to 3 Operational Range: same as data range
Type: Measured
Supporting information:
PGN 64986

SPN 2761 Joystick 3 Button 3 Pressed Status

Reports when the joystick button has been pressed.

00 Button not pressed
01 Button pressed
10 Error Indicator
11 Not Available

Data Length: 2 bits
Resolution: 4 states/2 bit, 0 offset
Data Range: 0 to 3 Operational Range: same as data range
Type: Measured
Supporting information:
PGN 64986

SPN 2762 Joystick 3 Button 4 Pressed Status

Reports when the joystick button has been pressed.

00 Button not pressed
01 Button pressed
10 Error Indicator
11 Not Available

Data Length: 2 bits
Resolution: 4 states/2 bit, 0 offset
Data Range: 0 to 3 Operational Range: same as data range
Type: Measured
Supporting information:
PGN 64986

SPN 2763 Joystick 3 Button 5 Pressed Status

Reports when the joystick button has been pressed.

00 Button not pressed
01 Button pressed
10 Error Indicator
11 Not Available

Data Length: 2 bits
Resolution: 4 states/2 bit, 0 offset
Data Range: 0 to 3 Operational Range: same as data range
Type: Measured
Supporting information:
PGN 64986

SPN 2764 Joystick 3 Button 6 Pressed Status

Reports when the joystick button has been pressed.

00 Button not pressed
01 Button pressed
10 Error Indicator
11 Not Available

Data Length: 2 bits
Resolution: 4 states/2 bit, 0 offset
Data Range: 0 to 3 Operational Range: same as data range
Type: Measured
Supporting information:
PGN 64986

SPN 2765 Joystick 3 Button 7 Pressed Status

Reports when the joystick button has been pressed.

00 Button not pressed
01 Button pressed
10 Error Indicator
11 Not Available

Data Length: 2 bits
Resolution: 4 states/2 bit, 0 offset
Data Range: 0 to 3 Operational Range: same as data range
Type: Measured
Supporting information:
PGN 64986

SPN 2766 Joystick 3 Button 8 Pressed Status

Reports when the joystick button has been pressed.

00 Button not pressed
01 Button pressed
10 Error Indicator
11 Not Available

Data Length: 2 bits
Resolution: 4 states/2 bit, 0 offset
Data Range: 0 to 3 Operational Range: same as data range
Type: Measured
Supporting information:
PGN 64986

SPN 2767 Joystick 3 Button 9 Pressed Status

Reports when the joystick button has been pressed.

00 Button not pressed
01 Button pressed
10 Error Indicator
11 Not Available

Data Length: 2 bits
Resolution: 4 states/2 bit, 0 offset
Data Range: 0 to 3 Operational Range: same as data range
Type: Measured
Supporting information:
PGN 64986

SPN 2768 Joystick 3 Button 10 Pressed Status

Reports when the joystick button has been pressed.

00 Button not pressed
01 Button pressed
10 Error Indicator
11 Not Available

Data Length: 2 bits
Resolution: 4 states/2 bit, 0 offset
Data Range: 0 to 3 Operational Range: same as data range
Type: Measured
Supporting information:
PGN 64986

SPN 2769 Joystick 3 Button 11 Pressed Status

Reports when the joystick button has been pressed.

00 Button not pressed
01 Button pressed
10 Error Indicator
11 Not Available

Data Length: 2 bits
Resolution: 4 states/2 bit, 0 offset
Data Range: 0 to 3 Operational Range: same as data range
Type: Measured
Supporting information:
PGN 64986

SPN 2770 Joystick 3 Button 12 Pressed Status

Reports when the joystick button has been pressed.

00 Button not pressed
01 Button pressed
10 Error Indicator
11 Not Available

Data Length: 2 bits
Resolution: 4 states/2 bit, 0 offset
Data Range: 0 to 3 Operational Range: same as data range
Type: Measured
Supporting information:
PGN 64986

SPN 2789 Engine Turbocharger 1 Calculated Turbine Inlet Temperature

Calculated value of turbine inlet temperature based on engine operating conditions, such as intake manifold temperature, charge fuel ratio, injection timing, and engine speed. Use SPN 1180 for actual measured inlet temperature.

Data Length: 2 bytes
 Resolution: 0.03125 deg C/bit, -273 deg C offset
 Data Range: -273 to 1735 deg C Operational Range: same as data range
 Type: Status
 Supporting information:
 PGN 64981

SPN 2790 Engine Turbocharger 1 Calculated Turbine Outlet Temperature

Calculated value of turbocharger compressor outlet air temperature. Temperature of air exiting the turbocharger compressor and before entering charge air cooler. The estimate is based on turbo speed and measured turbocharger compressor inlet temperature. Use SPN 1184 for actual measured outlet temperature.

Data Length: 2 bytes
 Resolution: 0.03125 deg C/bit, -273 deg C offset
 Data Range: -273 to 1735 deg C Operational Range: same as data range
 Type: Status
 Supporting information:
 PGN 64981

SPN 2791 Engine Exhaust Gas Recirculation (EGR) Valve Control

Desired percentage of maximum Exhaust Gas Recirculation (EGR) valve opening. 0% means valve is closed. 100% means maximum valve opening (full gas flow).

Data Length: 2 bytes
 Resolution: 0.0025 %/bit, 0 offset
 Data Range: 0 to 160.6375 % Operational Range: 0 to 100%
 Type: Status
 Supporting information:
 PGN 64981

SPN 2792 Engine Variable Geometry Turbocharger (VGT) Air Control Shutoff Valve

Isolates vehicle brake air from the Variable Geometry Turbocharger (VGT) system when engine is not running. This valve prevents vehicle air from bleeding off through the VGT Control Valve when engine is not in use. Primary vehicle air system from air tanks feed the VGT Air Control Shutoff Valve, which in turn provides air to the VGT Control Valve when the key switch is 'ON'. The VGT Control Valve delivers air to the VGT actuator to adjust turbocharger geometry.

00 VGT Air Control Shutoff Valve is Off
 01 VGT Air Control Shutoff Valve is On
 10 Reserved
 11 Not available

Data Length: 2 bits
 Resolution: 4 states/2 bit, 0 offset
 Data Range: 0 to 3 Operational Range: same as data range
 Type: Status
 Supporting information:
 PGN 64981

SPN 2793 Laser Strike Data Latency

Time from laser strike to CAN message transmission. This parameter will be reported by survey receiver type devices only. Byte 3 (SPN 2576) of PGN 65141 identifies the type of Laser Receiver.

Data Length: 2 bytes
 Resolution: 51.2 us/bit, 0 offset
 Data Range: 0 to 3.289856 s Operational Range: same as data range
 Type: Measured
 Supporting information:
 PGN 65141

SPN 2794 Absolute Laser Strike Position

Laser Strike location on the survey type laser receiver.

Data Length: 2 bytes
 Resolution: 0.1 mm/bit, 0 offset
 Data Range: 0 to 6,425.5 mm (0 to Operational Range: same as data range
 Type: Measured
 Supporting information:
 PGN 65141

SPN 2795 Engine Variable Geometry Turbocharger (VGT) 1 Actuator Position

Sensor that measures the position of the variable geometry turbocharger actuator. A position of 0% indicates the actuator is in the position creating the smallest geometry turbocharger. A position of 100% represents the largest geometry turbocharger.

Data Length: 1 byte
 Resolution: 0.4 %/bit, 0 offset
 Data Range: 0 to 100 % Operational Range: same as data range
 Type: Measured
 Supporting information:
 PGN 64981

SPN 2796 Transfer Case Selector Switch

Operator switch to select the condition of the transfer case. States 000 and 001 should be used if the transfer case only functions to switch between 2-wheel and 4-wheel drive. If the transfer case includes a High / Low Range function, states 011 and 100 should be supported as well. For reporting the status of the transfer case, see SPN 3645.

000: 2 wheel high (Normal or 'On Highway' Range)
 001: 4 wheel high (Normal or 'On Highway' Range)
 010: Neutral
 011: 2 wheel low (or 'Off Highway' Range)
 100: 4 wheel low (or 'Off Highway' Range)
 101: Reserved for SAE assignment
 110: Error indicator
 111: Not available

Data Length: 3 bits
 Resolution: 8 states/3 bit, 0 offset
 Data Range: 0 to 7 Operational Range: same as data range
 Type: Measured
 Supporting information:
 PGN 64980

SPN 2799 Engine Turbocharger 2 Compressor Outlet Temperature

Temperature of the air exiting the turbocharger 2 compressor outlet

Data Length: 2 bytes

Resolution: 0.03125 deg C/bit, -273 deg C offset

Data Range: -273 to 1735 deg C Operational Range: same as data range

Type: Measured

Supporting information:

PGN 64979

SPN 2800 Engine Turbocharger 3 Compressor Outlet Temperature

Temperature of the air exiting the turbocharger 3 compressor outlet

Data Length: 2 bytes

Resolution: 0.03125 deg C/bit, -273 deg C offset

Data Range: -273 to 1735 deg C Operational Range: same as data range

Type: Measured

Supporting information:

PGN 64979

SPN 2801 Engine Turbocharger 4 Compressor Outlet Temperature

Temperature of the air exiting the turbocharger 4 compressor outlet

Data Length: 2 bytes

Resolution: 0.03125 deg C/bit, -273 deg C offset

Data Range: -273 to 1735 deg C Operational Range: same as data range

Type: Measured

Supporting information:

PGN 64979

SPN 2802 Data Memory Usage

The used storage capacity of the data buffer memory internal to an ECU, such as a data logger.

Data Length: 1 byte

Resolution: 0.4 %/bit, 0 offset

Data Range: 0 to 100 % Operational Range: same as data range

Type: Measured

Supporting information:

PGN 64978

SPN 2803 *Keep-Alive Battery Consumption*

The capacity consumed from the direct battery connection since the key was last turned off. This value is maintained and does not accumulate while the key switch is on. The value is reset to 0 when the key switch is turned to the off position.

Data Length: 2 bytes

Resolution: 1 mAhr/bit, 0 offset

Data Range: 0 to 64255mAhr (64.255Ahr) Operational Range: same as data range

Type: Measured

Supporting information:

PGN 64978

SPN 2804 *FMS-standard Diagnostics Supported*

Status signal which indicates if the FMS Vehicle Interface (FMS Gateway) supports the handling of diagnostic messages from the vehicle network onto the FMS network.

The FMS gateway does NOT support the re-broadcast of diagnostics messages present on the vehicle network.

If this 'FMS-standard Diagnostics Supported' feature is supported by the FMS Gateway, the FMS Gateway will support the requests for diagnostics information (from the FMS device) onto the vehicle network and pass the responses onto the FMS network.

Note: This feature of the FMS Gateway is independent of the 'FMS-standard Requests Supported'. The FMS Gateway may support diagnostics without supporting the 'FMS-standard Requests Supported' function, or visa-versa.

00 Diagnostics Is Not Supported

01 Diagnostics Is Supported

10 Reserved

11 Don't care

Data Length: 2 bits

Resolution: 4 states/2 bit, 0 offset

Data Range: 0 to 3 Operational Range: same as data range

Type: Status

Supporting information:

PGN 64977

SPN 2805 FMS-standard Requests Supported

Status signal which indicates if the FMS Vehicle Interface (FMS Gateway) will respond to requests from the FMS device for the PGNs listed in the FMS Interface Specification.

This mode is to support FMS gateway devices that only operate in a 'Request' mode.

The FMS PGNs may also be broadcast periodically in this mode.

The FMS Gateway will NOT support the requests for information not included in the FMS Interface Specification onto the vehicle network."

00 On request mode is not supported

01 On request mode is supported

10 Reserved

11 Don't care

Data Length: 2 bits

Resolution: 4 states/2 bit, 0 offset

Data Range: 0 to 3

Operational Range: same as data range

Type: Status

Supporting information:

PGN 64977

SPN 2806 FMS-standard SW-version supported.

Information that identifies which issue level of the FMS-standard document the software included in the FMS gateway supports. Four bytes, representing xx.yy type revision level identification.

Information to be ASCII equivalent of the numeric revision level of the FMS document, 00.01 to 99.99. The first released version will be 01.00.

Note:

Byte 2 and byte 3 represents the SW version supported for trucks. Version number in the format ab.cd where Byte 2 represents "a" ASCII and Byte 3 represents "b" ASCII.

Byte 4 and byte 5 represents the SW version supported for bus and coaches; version number in the format ab.cd where Byte 4 represents "c" ASCII and Byte 5 represents "d" ASCII.

Data Length: 4 bytes

Resolution: ASCII, 0 offset

Data Range: 0 to 255 per byte

Operational Range: same as data range

Type: Measured

Supporting information:

PGN 64977

SPN 2807 Engine Fuel Shutoff 2 Control

Control setting for fuel shutoff 2. First instance is SPN 632. For a dual fuel shutoff system, this SPN is representative of the downstream fuel shutoff commanded position. When fuel (gas) is desired at the engine, the fuel shutoff is opened. Otherwise, it is closed.

00 = Open (fuel supplied to engine)
01 = Closed (no fuel supplied to engine)
10 = Reserved
11 = Don't care / take no action

In addition to communicating desired action of fuel shutoff 2 and its driver status, this new SPN can be used to communicate whether fuel shutoff 2 feedback position (if available) matches the commanded position, through the use of FMIs.

Data Length: 2 bits
Resolution: 4 states/2 bit, 0 offset
Data Range: 0 to 3 Operational Range: same as data range
Type: Status
Supporting information:
PGN 64914

SPN 2809 Engine Air Filter 2 Differential Pressure

Change in engine air system pressure, measured across the second air filter, due to the filter and any accumulation of solid foreign matter on or in the filter.

This is for monitoring the air filter on the inlet to the second turbocharger. Filter numbering follows the guidelines noted in section Naming Convention For Engine Parameters.

Data Length: 1 byte
Resolution: 0.05 kPa/bit, 0 offset
Data Range: 0 to 12.5 kPa Operational Range: same as data range
Type: Measured
Supporting information:
PGN 64976

SPN 2810 Engine Air Filter 3 Differential Pressure

Change in engine air system pressure, measured across the third air filter, due to the filter and any accumulation of solid foreign matter on or in the filter.

This is for monitoring the air filter on the inlet to the third turbocharger. Filter numbering follows the guidelines noted in section Naming Convention For Engine Parameters.

Data Length: 1 byte
Resolution: 0.05 kPa/bit, 0 offset
Data Range: 0 to 12.5 kPa Operational Range: same as data range
Type: Measured
Supporting information:
PGN 64976

SPN 2811 Engine Air Filter 4 Differential Pressure

Change in engine air system pressure, measured across the fourth air filter, due to the filter and any accumulation of solid foreign matter on or in the filter.

This is for monitoring the air filter on the inlet to the fourth turbocharger. Filter numbering follows the guidelines noted in section Naming Convention For Engine Parameters.

Data Length: 1 byte
Resolution: 0.05 kPa/bit, 0 offset
Data Range: 0 to 12.5 kPa Operational Range: same as data range
Type: Measured
Supporting information:
PGN 64976

SPN 2812 Engine Overspeed Test

The engine overspeed test signal as measured by the reporting ECM. Engine Overspeed Test is a mechanism to simulate engine overspeed situations, while operating the engine within the engine's safe operating range.

State signal which indicates when the overspeed test input to the ECM is being driven.

00 Engine Overspeed Test Not Active
01 Engine Overspeed Test Active
10 Reserved
11 Not Available

Data Length: 2 bits
Resolution: 4 states/2 bit, 0 offset
Data Range: 0 to 3 Operational Range: same as data range
Type: Measured
Supporting information:
PGN 65252

SPN 2813 Engine Air Shutoff Command Status

State signal which indicates when the Air Shutoff driver output is being driven. Disabled means controller wants air flowing to the engine. Status of the airflow shutoff as being commanded by the ECU.

00 Air Shutoff Disabled, not attempting to shutoff engine air supply
01 Air Shutoff Enabled, attempting to shutoff engine air supply
10 Reserved
11 Not Available

Data Length: 2 bits
Resolution: 4 states/2 bit, 0 offset
Data Range: 0 to 3 Operational Range: same as data range
Type: Status
Supporting information:
PGN 65252

SPN 2814 Engine Alarm Output Command Status

State signal which indicates when the Alarm driver output is being driven. Not active means the Controller has no alarm level conditions.

00 Engine Alarm Output Command Not Active
 01 Engine Alarm Output Command Active
 10 Reserved
 11 Not Available

Data Length: 2 bits
 Resolution: 4 states/2 bit, 0 offset
 Data Range: 0 to 3 Operational Range: same as data range
 Type: Status
 Supporting information:
 PGN 65252

SPN 2815 Engine Alarm Acknowledge

The Engine Alarm Acknowledge Input signal as measured by the reporting ECM. The Engine Alarm Acknowledge is a mechanism for external acknowledgement of the SPN 2814, Engine Alarm Output Command.

00 Engine Alarm Acknowledge Not Active
 01 Engine Alarm Acknowledge Active
 10 Error
 11 Not Available

Data Length: 2 bits
 Resolution: 4 states/2 bit, 0 offset
 Data Range: 0 to 3 Operational Range: same as data range
 Type: Measured
 Supporting information:
 PGN 65252

SPN 2863 Front Operator Wiper Switch

State of operation selected by operator switch for the Wiper in front of the operator position. This parameter, 'Front Operator Wiper Switch' should be used for the control information if either of the other wiper switch parameters is 'Not Available' and the associated wiper still needs to be controlled.

0000 Off
 0001 Low
 0010 Medium
 0011 High
 0100 Delayed 1 (used for the first delay choice when the wiper switch position controls the delay)
 0101 Delayed 2 (used for the second delay choice when the wiper switch position controls the delay)
 0110 Mist (position where external sensor controls wiper rate)
 0111 - 1110 Reserved
 1111 Not available (do not change)

Data Length: 4 bits
 Resolution: 16 states/4 bit, 0 offset
 Data Range: 0 to 15 Operational Range: same as data range
 Type: Measured
 Supporting information:
 PGN 64973

SPN 2864 Front Non-operator Wiper Switch

State of operation selected by operator switch for the front wiper not in front of the operator position. The parameter, 'Front Operator Washer Switch' should be used for the control information if this parameter is 'Not Available' and the associated washer still needs to be controlled.

0000 Off
0001 Low
0010 Medium
0011 High
0100 Delayed 1 (used for the first delay choice when the wiper switch position controls the delay)
0101 Delayed 2 (used for the second delay choice when the wiper switch position controls the delay)
0110 Mist (position where external sensor controls wiper rate)
0111 - 1110 Reserved
1111 Not available (do not change)

Data Length: 4 bits
Resolution: 16 states/4 bit, 0 offset
Data Range: 0 to 15 Operational Range: same as data range
Type: Measured
Supporting information:
PGN 64973

SPN 2865 Rear Wiper Switch

State of operation selected by operator switch for the rear wiper. The parameter, 'Front Operator Washer Switch' should be used for the control information if this parameter is 'Not Available' and the associated washer still needs to be controlled.

0000 Off
0001 Low
0010 Medium
0011 High
0100 Delayed 1 (used for the first delay choice when the wiper switch position controls the delay)
0101 Delayed 2 (used for the second delay choice when the wiper switch position controls the delay)
0110 Mist (position where external sensor controls wiper rate)
0111 - 1110 Reserved
1111 Not available (do not change)

Data Length: 4 bits
Resolution: 16 states/4 bit, 0 offset
Data Range: 0 to 15 Operational Range: same as data range
Type: Measured
Supporting information:
PGN 64973

SPN 2866 Front Operator Washer Switch

State of operation selected by operator switch for the washer in front of the operator position. This parameter, 'Front Operator Washer Switch' should be used for the control information if either of the other washer switch parameters is 'Not Available' and the associated washer still needs to be controlled.

000 Off
001 Low
010 Medium
011 High
100 - 110 Reserved
111 Not available (do not change)

Data Length: 3 bits
Resolution: 8 states/3 bit, 0 offset
Data Range: 0 to 7 Operational Range: same as data range
Type: Measured
Supporting information:
PGN 64973

SPN 2867 Front Non-operator Washer Switch

State of operation selected by operator switch for the front washer not in front of the operator position. The parameter, 'Front Operator Washer Switch' should be used for the control information if this parameter is 'Not Available' and the associated washer still needs to be controlled.

000 Off
001 Low
010 Medium
011 High
100 - 110 Reserved
111 Not available (do not change)

Data Length: 3 bits
Resolution: 8 states/3 bit, 0 offset
Data Range: 0 to 7 Operational Range: same as data range
Type: Measured
Supporting information:
PGN 64973

SPN 2868 Rear Washer Function

State of operation selected by operator switch for the rear washer. The parameter, 'Front Operator Washer Switch' should be used for the control information if this parameter is 'Not Available' and the associated washer still needs to be controlled.

000 Off
001 Low
010 Medium
011 High
100 - 110 Reserved
111 Not available (do not change)

Data Length: 3 bits
Resolution: 8 states/3 bit, 0 offset
Data Range: 0 to 7 Operational Range: same as data range
Type: Measured
Supporting information:
PGN 64973

SPN 2869 *Front Operator Wiper Delay Control*

Time between cycles of the front operator side wiper (i.e. from end of cycle 'n' to start of cycle 'n+1') as selected by the operator control (switch, etc.) in percentage of position with maximum position corresponding to maximum delay selectable.

This parameter, 'Front Operator Wiper Delay Control' should be used for the delay information if either of the other delay parameters is 'Not Available' and the function needs to be provided.

Data Length: 1 byte
Resolution: 0.4 %/bit, 0 offset
Data Range: 0 to 100 % Operational Range: same as data range
Type: Measured
Supporting information:
PGN 64973

SPN 2870 *Front Non-operator Wiper Delay Control*

Time between cycles of the front non-operator side wiper (i.e. from end of cycle 'n' to start of cycle 'n+1') as selected by the operator control (switch, etc.) in percentage of position with maximum position corresponding to maximum delay selectable. The parameter, 'Front Operator Wiper Delay Control' should be used for the delay information if this parameter is 'Not Available' and the function needs to be provided.

Data Length: 1 byte
Resolution: 0.4 %/bit, 0 offset
Data Range: 0 to 100 % Operational Range: same as data range
Type: Measured
Supporting information:
PGN 64973

SPN 2871 *Rear Wiper Delay Control*

Time between cycles of the rear wiper (i.e. from end of cycle 'n' to start of cycle 'n+1') as selected by the operator control (switch, etc.) in percentage of position with maximum position corresponding to maximum delay selectable. The parameter, 'Front Operator Wiper Delay Control' should be used for the delay information if this parameter is 'Not Available' and the function needs to be provided.

Data Length: 1 byte
Resolution: 0.4 %/bit, 0 offset
Data Range: 0 to 100 % Operational Range: same as data range
Type: Measured
Supporting information:
PGN 64973

SPN 2872 Main Light Switch

A 4 bit parameter to indicate the selected position of the operator's main light switch.

0000 Off - The position by which the operator selects that none of the lamps are to be on.
0001 Park On - The position by which the operator selects that the park lamps are to be on.
0010 Headlight On - The position by which the operator selects that the headlamps are to be on.
0011 Headlight and Park On - The position by which the operator selects that Both the Headlamps and the Park lamps are to be on.
0100 - 0111 Reserved
1000 Delayed Off - The position by which the operator selects that a certain set of lamps are to come On and then are to be turned Off following a delay time (Operators Desired - Delayed Lamp Off Time).
1001 - 1101 Reserved
1110 Error
1111 Not available (do not change)

Data Length: 4 bits
Resolution: 16 states/4 bit, 0 offset
Data Range: 0 to 15 Operational Range: same as data range
Type: Measured
Supporting information:
PGN 64972

SPN 2873 Work Light Switch

A 4 bit parameter to indicate the selected position of the operator's work light switch. In Ag applications the work lights are often referred to as field lights. In on-highway applications the work lights are often referred to as clearance lights and may or may not be operated by a switch separate from the main light switch.

0000 Off - The position by which the operator selects that none of the work lamps are to be on.
0001 Work Light Combination #1 On - The position by which the operator selects that the lamps in the combination defined as Work Light Combination #1 are to be on.
0010 Work Light Combination #2 On - The position by which the operator selects that the lamps in the combination defined as Work Light Combination #2 are to be on.
0011 Work Light Combination #3 On - The position by which the operator selects that the lamps in the combination defined as Work Light Combination #3 are to be on.
0100 Work Light Combination #4 On - The position by which the operator selects that the lamps in the combination defined as Work Light Combination #4 are to be on.
0101-1101 Reserved
1110 Error
1111 Not available (do not change)

Data Length: 4 bits
Resolution: 16 states/4 bit, 0 offset
Data Range: 0 to 15 Operational Range: same as data range
Type: Measured
Supporting information:
PGN 64972

SPN 2874 High-Low Beam Switch

A 2 bit parameter to indicate the selected position of the operator's high/low beam select switch.

00 Low Beam Selected
01 High Beam Selected
10 Error
11 Not available (do not change)

Data Length: 2 bits
Resolution: 4 states/2 bit, 0 offset
Data Range: 0 to 3 Operational Range: same as data range
Type: Measured
Supporting information:
PGN 64972

SPN 2875 Hazard Light Switch

A 2 bit parameter to indicate the selected position of the operator's hazard light switch.

00 Hazard Lamps to be Off
01 Hazard Lamps to be Flashing
10 Error
11 Not available (do not change)

Data Length: 2 bits
Resolution: 4 states/2 bit, 0 offset
Data Range: 0 to 3 Operational Range: same as data range
Type: Measured
Supporting information:
PGN 64972

SPN 2876 Turn Signal Switch

A 4 bit parameter to indicate the selected position of the operator's turn signal switch.

0000 No Turn being signaled
0001 Left Turn to be Flashing
0010 Right turn to be Flashing
0011 - 1101 Reserved
1110 Error (to include both left and right selected simultaneously)
1111 Not available (do not change)

Data Length: 4 bits
Resolution: 16 states/4 bit, 0 offset
Data Range: 0 to 15 Operational Range: same as data range
Type: Measured
Supporting information:
PGN 64972

SPN 2877 *Operators Desired - Delayed Lamp Off Time*

A 16 bit parameter to be associated with Delayed Off position (1000 binary) of the Main Light Switch. This parameter indicates the time the operator wishes to have elapse following the Main Light switch being placed in Delayed Off position before the defined lights turn back off. The Operator's definition as to which lamps are to turn On (and then Off of course) when the Main Light Switch is in the Delayed Off position. The specific lamps are not identified within this message, but are to be stored by whatever device (ecu) is planning to send the lamp command message for said lamps. Said device must also provide the means for the operator to enter and/or adjust said definition.

Data Length: 2 bytes
 Resolution: 1 s/bit, 0 offset
 Data Range: 0 to 64,255 s Operational Range: same as data range
 Type: Measured
 Supporting information:
 PGN 64972

SPN 2878 *Operators Desired Back-light*

A 8 bit parameter to indicate the level of back lighting the operator has selected for displays. This is to be differentiated from the Illumination Brightness Percent (SPN:1487 PGN:53248 Cab Illumination Message) which is sent to the displays to tell them what level to be at. This is the operator desired level (as sensed by operator controls) for those system where the operator controls are monitored by an ecu separate from the ecu sending the command to the displays. Note each display (if appropriate) will need to have its own balance function to compensate its nominal brightness to the same level of that of all other displays. This is especially important for systems with back-lights which may change noticeable with aging. In other words it will be necessary within a vehicle to scale all of the displays down to the same level as the dimmest display (since, obviously you can not make the dimmest brighter).

Data Length: 1 byte
 Resolution: 0.4 %/bit, 0 offset
 Data Range: 0 to 100 % Operational Range: same as data range
 Type: Measured
 Supporting information:
 PGN 64972

SPN 2879 *Engine Alternate Droop Accelerator 2 Select*

Same description as Engine Alternate Droop Accelerator 1 Select (SPN 2881) except that the selections may apply to Accelerator 2.

0000 – Normal Droop Setting is selected
 0001 thru 1101 – One of Alternate Droop Setting 1 through 13 (in sequential order) is selected
 1110 – Error condition
 1111 – Not available

Data Length: 4 bits
 Resolution: 16 states/4 bit, 0 offset
 Data Range: 0 to 15 Operational Range: same as data range
 Type: Measured
 Supporting information:
 PGN 64971

SPN 2880 Engine Operator Primary Intermediate Speed Select

Allows the operator to select one of 13 preprogrammed Intermediate Speed Control settings. If no speed setting is requested, the engine operates normally. The Intermediate Speed Control is widely used in the Industrial application to control the engine to an intermediate speed setting which can either replace the accelerator position control altogether, or limit the accelerator position control to a selectable speed point minimum or maximum.

0000 – indicates that the ISC functionality is not requested, engine operates normally
0001 thru 1101 – indicates that the ISC Setting 1 thru 13 (in sequential order) is selected
1110 – error condition
1111 – not available

Data Length: 4 bits
Resolution: 16 states/4 bit, 0 offset
Data Range: 0 to 15 Operational Range: same as data range
Type: Measured
Supporting information:
PGN 64970

SPN 2881 Engine Alternate Droop Accelerator 1 Select

In some off-highway applications it may be desirable to have multiple droop settings available across the range of engine operation. For example, in an agricultural tractor application, this functionality allows a higher engine speed during low load so as to maximize vehicle speed driven between fields on the road. Another use of the alternate droop settings would be to provide functionality for maintaining an engine speed independent of the applied load on demand. There is a normal droop setting, and up to 13 additional preprogrammed droop settings which are user selectable by switching. The selections apply to Accelerator 1.

0000 – Normal Droop Setting is selected
0001 thru 1101 – One of Alternate Droop Setting 1 through 13 (in sequential order) is selected
1110 – Error condition
1111 – Not available

Data Length: 4 bits
Resolution: 16 states/4 bit, 0 offset
Data Range: 0 to 15 Operational Range: same as data range
Type: Measured
Supporting information:
PGN 64971

SPN 2882 Engine Alternate Rating Select

In some off-highway applications it may be desirable to have multiple engine ratings available for selection by the operator. There is the default engine rating, which provides the maximum available power across the range of operation. There are additional engine ratings which the user can select that allow for alternate fueling across the operational range. Engine rating selection number 1 is the maximum rating. Selection number 2 is the next highest, selection 3 next highest, etc. The selection impacts the operating points in the Engine Configuration.

0 – indicates that Maximum Power Fueling is selected
 1 – indicates that the Alternate Power Fueling 1 is selected
 2 – indicates that the Alternate Power Fueling 2 is selected
 3 – indicates that the Alternate Power Fueling 3 is selected
 4 thru 253 - indicates that the Alternate Power Fueling 4 thru 253 (in sequential order) is selected.
 254 – Error condition.
 255 – Not available

Data Length: 1 byte
 Resolution: 1 selection/bit, 0 offset
 Data Range: 0 to 255 Operational Range: same as data range
 Type: Measured
 Supporting information:
 PGN 64971

SPN 2883 Engine Alternate Low Idle Switch

Operator switch which selects between two low idle speeds, default and alternate.

The normal programmed low idle is the default low idle, and when the Alternate Low Idle switch is activated, a alternate preprogrammed low idle speed is selected. The accelerator position control operates as normal but is now bounded to a different low idle speed. This selection impacts Point 1 on the Engine Configuration.

00 Default low idle point is selected
 01 Alternate low idle point is selected
 10 Error
 11 Not available or Unused

Data Length: 2 bits
 Resolution: 4 states/2 bit, 0 offset
 Data Range: 0 to 3 Operational Range: same as data range
 Type: Measured
 Supporting information:
 PGN 64971

SPN 2884 Engine Auxiliary Governor Switch

This is the On/Off operation of the Auxiliary Governor feature switch. This feature is used to allow engine speed to be controlled by an auxiliary input such as pressure or tailshaft speed. This switch position indicates whether this feature is requested or not.

00 – Auxiliary Governor is disabled
 01 – Auxiliary Governor is enabled
 10 – Error condition
 11 – Not available

Data Length: 2 bits
 Resolution: 4 states/2 bit, 0 offset
 Data Range: 0 to 3 Operational Range: same as data range
 Type: Measured
 Supporting information:
 PGN 64971

SPN 2885 Engine Alternate Droop Auxiliary Input Select

In some off-highway applications it may be desirable to have multiple droop settings available across the range of engine operation. For example, in an agricultural tractor application, this functionality allows a higher engine speed during low load so as to maximize vehicle speed driven between fields on the road. Another use of the alternate droop settings would be to provide functionality for maintaining an engine speed independent of the applied load on demand. There is a normal droop setting, and up to 13 additional preprogrammed droop settings which are user selectable by switching. The selections apply to the Alternate Droop Auxiliary Input.

0000 – Normal Droop Setting is selected

0001 thru 1101 – One of Alternate Droop Setting 1 through 13 (in sequential order) is selected

1110 – Error condition

1111 – Not available

Data Length: 4 bits
 Resolution: 16 states/4 bit, 0 offset
 Data Range: 0 to 15 Operational Range: same as data range
 Type: Measured
 Supporting information:
 PGN 64971

SPN 2886 Engine Alternate Droop Remote Accelerator Select

In some off-highway applications it may be desirable to have multiple droop settings available across the range of engine operation. For example, in an agricultural tractor application, this functionality allows a higher engine speed during low load so as to maximize vehicle speed driven between fields on the road. Another use of the alternate droop settings would be to provide functionality for maintaining an engine speed independent of the applied load on demand. There is a normal droop setting, and up to 13 additional preprogrammed droop settings which are user selectable by switching. The selections apply to the Remote Accelerator.

0000 – Normal Droop Setting is selected

0001 thru 1101 – One of Alternate Droop Setting 1 through 13 (in sequential order) is selected

1110 – Error condition

1111 – Not available

Data Length: 4 bits
 Resolution: 16 states/4 bit, 0 offset
 Data Range: 0 to 15 Operational Range: same as data range
 Type: Measured
 Supporting information:
 PGN 64971

SPN 2887 Total Count of Configuration Changes Made

Total number of times changes have been made to any of the configurable parameters.

Data Length: 2 bytes
 Resolution: 1 count/bit, 0 offset
 Data Range: 0 to 64,255 counts Operational Range: same as data range
 Type: Measured
 Supporting information:
 PGN 64969

SPN 2888 Engine Alternate Rating Select State

In some off-highway applications it may be desirable to have multiple engine ratings available for selection by the operator. There is the default engine rating, which provides the maximum available power across the range of operation. There are additional engine ratings which the engine controller may use that allow for alternate fueling across the operational range. Engine rating number 1 is the maximum rating. Rating number 2 is the next highest, rating 3 next highest, etc.

00 – Control state is Maximum Power Fueling
 01 – Control state is Alternate Power Fueling 1
 02 – Control state is Alternate Power Fueling 2
 03 – Control state is Alternate Power Fueling 3
 04 thru 253 - Control state is Alternate Power Fueling 4 thru 253 (in sequential order)
 254 – SAE reserved
 255 – Not available
 Data Length: 8 bits
 Resolution: 256 states/8 bit, 0 offset
 Data Range: 0 to 255 Operational Range: same as data range
 Type: Status
 Supporting information:
 PGN 64967

SPN 2889 Engine Alternate Droop Accelerator 1 Select State

In some off-highway applications it may be desirable to have multiple droop settings available across the range of engine operation. For example, in an agricultural tractor application, this functionality allows a higher engine speed during low load so as to maximize vehicle speed driven between fields on the road. Another use of the alternate droop settings would be to provide functionality for maintaining an engine speed independent of the applied load on demand. There is a normal droop setting, and up to 13 additional preprogrammed droop settings which are user selectable by switching. The selections may apply to Accelerator 1. This parameter indicates which state has been selected by the controlling ECM.

0000 – Control state is Normal Droop Setting
 0001 thru 1101 – Control state is one of Alternate Droop Setting 1 through 13 (in sequential order)
 1110 – SAE reserved
 1111 – Not available
 Data Length: 4 bits
 Resolution: 16 states/4 bit, 0 offset
 Data Range: 0 to 15 Operational Range: same as data range
 Type: Status
 Supporting information:
 PGN 64967

SPN 2890 Engine Multi-Unit Sync State

This feature is widely used in Industry to operate multiple engines from a single command source. A master engine will “synchronize” one or more slave engines to operate at the same speed. This feature is requested by an operator switch, this parameter indicates the state of the feature as determined by the controlling ECM.

00 Control State is Functionality disabled (off)
 01 Control State is Functionality enabled (on)
 10 SAE reserved
 11 Not available
 Data Length: 2 bits
 Resolution: 4 states/2 bit, 0 offset
 Data Range: 0 to 3 Operational Range: same as data range
 Type: Status
 Supporting information:
 PGN 64967

SPN 2891 Engine Alternate Low Idle Select State

In many applications, it is desirable that an alternate low idle speed setting be made available via switch input. The normal programmed low idle is the default low idle, and when the Alternate Low Idle feature is activated, an alternate preprogrammed low idle speed is selected. The accelerator position control operates as normal but is now bounded to a different low idle speed. This selection impacts Point 1 on the Engine Configuration.

00 – Normal idle state
01 – Alternate idle state
10 – SAE reserved
11 – not available

Data Length: 2 bits
Resolution: 4 states/2 bit, 0 offset
Data Range: 0 to 3 Operational Range: same as data range
Type: Status
Supporting information:
PGN 64967

SPN 2892 Engine Operator Primary Intermediate Speed Select State

13 preprogrammed intermediate speed control settings are available for the controlling ECM to select. If no speed setting is requested, the engine operates normally. The Intermediate Speed Control is widely used in the Industrial application to control the engine to an intermediate speed setting which can either replace the accelerator position control altogether, or limit the accelerator position control to a selectable speed point minimum or maximum. This parameter indicates which state has been selected by the controlling ECM.

0000 – Control state is ISC functionality is not requested, engine operates normally
0001 thru 1101 – Control state is ISC Setting 1 thru 13 (in sequential order)
1110 – SAE reserved
1111 – not available

Data Length: 4 bits
Resolution: 16 states/4 bit, 0 offset
Data Range: 0 to 15 Operational Range: same as data range
Type: Status
Supporting information:
PGN 64968

SPN 2893 Engine Alternate Droop Accelerator 2 Select State

In some off-highway applications it may be desirable to have multiple droop settings available across the range of engine operation. For example, in an agricultural tractor application, this functionality allows a higher engine speed during low load so as to maximize vehicle speed driven between fields on the road. Another use of the alternate droop settings would be to provide functionality for maintaining an engine speed independent of the applied load on demand. There is a normal droop setting, and up to 13 additional preprogrammed droop settings which are user selectable by switching. The selections apply to Accelerator 2.

0000 – Control's state is Normal Droop Setting
0001 thru 1101 – Control's state is One of Alternate Droop Setting 1 through 13 (in sequential order)
1110 – SAE reserved
1111 – Not available

Data Length: 4 bits
Resolution: 16 states/4 bit, 0 offset
Data Range: 0 to 15 Operational Range: same as data range
Type: Status
Supporting information:
PGN 64967

SPN 2894 Engine Alternate Droop Remote Accelerator Select State

In some off-highway applications it may be desirable to have multiple droop settings available across the range of engine operation. For example, in an agricultural tractor application, this functionality allows a higher engine speed during low load so as to maximize vehicle speed driven between fields on the road. Another use of the alternate droop settings would be to provide functionality for maintaining an engine speed independent of the applied load on demand. There is a normal droop setting, and up to 13 additional preprogrammed droop settings which are user selectable by switching. The selections apply to Remote Accelerator.

0000 – Control state is Normal Droop Setting
 0001 thru 1101 – Control state is One of Alternate Droop Setting 1 through 13 (in sequential order)
 1110 – SAE reserved
 1111 – Not available

Data Length: 4 bits
 Resolution: 16 states/4 bit, 0 offset
 Data Range: 0 to 15 Operational Range: same as data range
 Type: Status
 Supporting information:
 PGN 64967

SPN 2895 Engine Alternate Droop Auxiliary Input Select State

In some off-highway applications it may be desirable to have multiple droop settings available across the range of engine operation. For example, in an agricultural tractor application, this functionality allows a higher engine speed during low load so as to maximize vehicle speed driven between fields on the road. Another use of the alternate droop settings would be to provide functionality for maintaining an engine speed independent of the applied load on demand. There is a normal droop setting, and up to 13 additional preprogrammed droop settings which are user selectable by switching. The selections apply to Auxiliary Input.

0000 – Control state is Normal Droop Setting
 0001 thru 1101 – Control state is One of Alternate Droop Setting 1 through 13 (in sequential order)
 1110 – SAE reserved
 1111 – Not available

Data Length: 4 bits
 Resolution: 16 states/4 bit, 0 offset
 Data Range: 0 to 15 Operational Range: same as data range
 Type: Status
 Supporting information:
 PGN 64967

SPN 2896 Engine Auxiliary Governor State

This is the Engine Auxiliary Governor feature. This feature is used to allow engine speed to be controlled by an auxiliary input such as pressure or tailshaft speed. This feature is requested by an operator switch, this parameter indicates the state of the feature as determined by the controlling ECM.

00 – Control State is Auxiliary Governor disabled
 01 – Control State is Auxiliary Governor enabled
 10 – SAE reserved
 11 – Not available

Data Length: 2 bits
 Resolution: 4 states/2 bit, 0 offset
 Data Range: 0 to 3 Operational Range: same as data range
 Type: Status
 Supporting information:
 PGN 64967

SPN 2897 (R) Operator Engine PTO Governor Memory Select Switch

Measured state of the operator's engine PTO governor memory select switch. This switch selects which of the two available memory locations is to be used to store the dynamically assigned value. This speed will be set using the PTO governor set switch and modified using the PTO governor accelerate and coast/decelerate switches.

00 PTO set speed memory 1 selected
01 PTO set speed memory 2 selected
10 error
11 not available

Data Length: 2 bits
Resolution: 4 states/2 bit, 0 offset
Data Range: 0 to 3 Operational Range: same as data range
Type: Measured
Supporting information:
PGN 65264

SPN 2898 Engine Start Enable Device 2 Configuration

The start enable device installed for start enable device 2.

0000 - no start enable device 2 installed
0001 - glow plugs installed
0010 - fuelled start installed
0011 - ether injection installed
0100 - electric inlet air heater installed
0101 - 1110 - reserved
1111 - not available

Data Length: 4 bits
Resolution: 16 states/4 bit, 0 offset
Data Range: 0 to 15 Operational Range: same as data range
Type: Status
Supporting information:
PGN 64966

SPN 2899 Engine Start Enable Device 1 Configuration

The start enable device installed for start enable device 1.

0000 - no start enable device 1 installed
0001 - glow plugs installed
0010 - fuelled start installed
0011 - ether injection installed
0100 - electric inlet air heater installed
0101 - 1110 - reserved
1111 - not available

Data Length: 4 bits
Resolution: 16 states/4 bit, 0 offset
Data Range: 0 to 15 Operational Range: same as data range
Type: Status
Supporting information:
PGN 64966

SPN 2900 Transmission Engine Crank Enable

State signal from the transmission indicating if the transmission's status is such that engine cranking is allowed (i.e. at a minimum, transmission is in neutral and the driveline is disengaged). As sender of this information, the transmission is responsible for correct indication immediately upon first broadcast of this parameter.

As with hard-wired neutral start implementations, those utilizing this parameter should consider the impact of the transmission or other controllers 'resetting' due to voltage drops during the engine start sequence.

The vehicle system design should also consider the impact of timing latency in the engine starting sequence. For example, the turn of an ignition key from 'off' to 'start' may happen more quickly than the transmission controller can boot up, determine its' current state of being, and begin broadcasting information over the J1939 datalink.

00 - Cranking disabled; engine cranking is prohibited by the transmission
01 - Cranking enabled; engine cranking is allowed by the transmission
10 - Error
11 - Not available

Data Length: 2 bits
Resolution: 4 states/2 bit, 0 offset
Data Range: 0 to 3 Operational Range: same as data range
Type: Status
Supporting information:
PGN 65098

SPN 2901 ECU Part Number

The part number of the physical ECU.

Data Length: Variable - up to 200 characters ("*" delimited)
Resolution: ASCII, 0 offset
Data Range: 0 to 255 per byte Operational Range: same as data range
Type: Measured
Supporting information:
PGN 64965

SPN 2902 ECU Serial Number

The serial number of the physical ECU.

Data Length: Variable - up to 200 characters ("*" delimited)
Resolution: ASCII, 0 offset
Data Range: 0 to 255 per byte Operational Range: same as data range
Type: Measured
Supporting information:
PGN 64965

SPN 2903 ECU Location

The location of the ECU within a network.

Data Length: Variable - up to 200 characters ("*" delimited)

Resolution: ASCII, 0 offset

Data Range: 0 to 255 per byte Operational Range: same as data range

Type: Measured

Supporting information:

PGN 64965

SPN 2904 ECU Type

The type of ECU. One example of a use of the ECU type could be for classifying ECU capabilities, such as I/O.

Data Length: Variable - up to 200 characters ("*" delimited)

Resolution: ASCII, 0 offset

Data Range: 0 to 255 per byte Operational Range: same as data range

Type: Measured

Supporting information:

PGN 64965

SPN 2911 Halt brake switch

Switch signal which indicates the position of the halt brake switch.

00 Halt brake switch passive

01 Halt brake switch active

10 Error

11 Not available

Data Length: 2 bits

Resolution: 4 states/2 bit, 0 offset

Data Range: 0 to 3 Operational Range: same as data range

Type: Measured

Supporting information:

PGN 61441

SPN 2912 (R) Hill holder mode

Signal which indicates the current mode of the hill holder function.

000 Inactive

001 Active

010 Active, but will change to inactive in a short time. (This mode may be used to warn the driver)

011 - 101 Reserved

110 Hill holder not functional

111 Not available

Data Length: 3 bits

Resolution: 8 states/3 bit, 0 offset

Data Range: 0 to 7 Operational Range: same as data range

Type: Status

Supporting information:

PGN 64964

SPN 2913 Halt brake mode

Signal which indicates the current mode of the halt brake function.

000	Inactive	
001	Active	
010	Active, but not functioning properly. (This mode may be used to warn the driver)	
011 - 101	Not defined	
110	Reserved	
111	Not available	

Data Length:	3 bits	
Resolution:	8 states/3 bit, 0 offset	
Data Range:	0 to 7	Operational Range: same as data range
Type:	Status	
Supporting information:		
PGN	64964	

SPN 2914 XBR EBI Mode

The XBR EBI (Endurance Brake Integration) Mode is used as an input for the brake system to prescribe the use of endurance brakes like retarders or engine brakes.

00 - No Endurance Brake Integration allowed

The demanded acceleration must be realized by the brake system by using only the foundation brakes. During an active XBR request, the brake system must not actively demand brake torque from other braking devices like retarders or engine brakes.

01 - Only Endurance Brakes allowed

The demanded acceleration must be realized by the brake system by demanding brake torque from other brake devices like retarders or engine brakes. The foundation brake itself must not be used (e.g. to reduce brake lining wear).

10 - Endurance Brake Integration allowed

The demanded acceleration may be realized by the brake system by using the foundation brakes and/or by demanding brake torque from other brake devices like retarders or engine brakes.

11 - Not defined

Data Length:	2 bits	
Resolution:	4 states/2 bit, 0 offset	
Data Range:	0 to 3	Operational Range: same as data range
Type:	Status	
Supporting information:		
PGN	1024	

SPN 2915 XBR Priority

The XBR Priority is used as an input to the brake system to manage the priority of overlapping external and internal requests.

00 - Highest priority – used for emergency situations, e.g. for future Collision Avoidance System. This mode overrides any brake protection measures of the brake system.

01 - High priority – not defined

10 - Medium priority – used for ACC-Systems. This mode does not override brake protection measures of the brake system.

11 - Low priority – used in "override disabled" XBR Control Mode

Data Length:	2 bits	
Resolution:	4 states/2 bit, 0 offset	
Data Range:	0 to 3	Operational Range: same as data range
Type:	Status	
Supporting information:		
PGN	1024	

SPN 2919 Foundation Brake Use

This parameter indicates if the brake system presently uses the foundation brakes.

00 Foundation brakes not in use
 01 Foundation brakes in use
 10 Reserved
 11 Not available

Data Length: 2 bits
 Resolution: 4 states/2 bit, 0 offset
 Data Range: 0 to 3 Operational Range: same as data range
 Type: Status
 Supporting information:
 PGN 64964

SPN 2920 External Acceleration Demand

Parameter provided to the brake system from external sources. This is the acceleration which the brake system is expected to realize. It is specified as an absolute acceleration in reference to the road. Positive values lead to increasing vehicle speed, negative values lead to decreasing vehicle speed. Note: Normally only the negative data range is used, but e.g. in case of downhill driving also positive values are possible.

Data Length: 2 bytes
 Resolution: 1/2048 m/s² per bit, -15.687 m/s² offset
 Data Range: -15.687 to +15.687 m/s² Operational Range: -10.0 to +10.0 m/s²
 Type: Status
 Supporting information:
 PGN 1024

SPN 2921 XBR Acceleration Limit

The brake system may temporarily or generally limit the maximum brake performance available for external systems. A temporary limit may be necessary due to high brake temperature; a general limit may be defined by the vehicle manufacturer, e.g. a value of -2.5 m/s² due to liability reasons. The actual limit is communicated to the external systems that request braking. The limit is only effective in the XBR Priorities 01 to 11. It is specified as an absolute acceleration in reference to the road.

Data Length: 1 byte
 Resolution: 0.1 m/s² per bit, -12.5 m/s² offset
 Data Range: -12.5 to +12.5 m/s² Operational Range: -10.0 to +10.0 m/s²
 Type: Status
 Supporting information:
 PGN 64964

SPN 2922 Steerable Lift Axle Lowering Inhibit

A signal which indicates if lowering of lifted axle is allowed or inhibited.

00 Lowering allowed
 01 Lowering inhibited
 10 Reserved
 11 Not available

Data Length: 2 bits
 Resolution: 4 states/2 bit, 0 offset
 Data Range: 0 to 3 Operational Range: same as data range
 Type: Status
 Supporting information:
 PGN 61451

SPN 2923 Status of Steering Axle

A signal which indicates different states of the steering axle

0000 Axle steering not active (adhesion steering)
 0001 Axle steering active
 0010 Axle centered
 0011 Axle centered, because of an error
 0100 Axle not active because of an error (adhesion steering)
 0101 Axle steering in special mode (diagnosis, calibration mode)
 0110-1110 Reserved for SAE Assignment
 1111 Not available

Data Length: 4 bits
 Resolution: 16 states/4 bit, 0 offset
 Data Range: 0 to 15 Operational Range: same as data range
 Type: Status
 Supporting information:
 PGN 61451

SPN 2924 Steering Type

Indicates the different types of steering systems (ref. ECE Regulation 79 paragraph 2.5)

0000 Main steering system
 0001 Auxiliary steering equipment
 0010-1110 Reserved for Assignment by SAE
 1111 Not Available

0000 Main steering system - The steering equipment of a vehicle which is mainly responsible for determining the direction of travel.

0001 Auxiliary steering equipment - A system in which the wheels on axle(s) of vehicles of categories M and N are steered in addition to the wheels of the main steering equipment in the same or opposite direction to those of the main steering equipment and/or the steering angle of the front and/or the rear wheels may be adjusted relative to vehicle behaviour.

Data Length: 4 bits
 Resolution: 16 states/4 bit, 0 offset
 Data Range: 0 to 15 Operational Range: same as data range
 Type: Status
 Supporting information:
 PGN 61451

SPN 2925 *Type of Steering Forces*

Type of Steering Forces (Ref. ECE Regulation 79 paragraph 2.5)

0000	Manual steering equipment
0001	Power assisted steering equipment
0010	Full power steering equipment
0011	Self tracking steering equipment
0100-1110	Reserved for SAE assignment
1111	Not Available

0000 Manual steering equipment - The steering forces result solely from the muscular effort of the driver.

0001 Power assisted steering equipment - The steering forces result from both the muscular effort of the driver and the energy supply or supplies.

0010 Full power steering equipment - The steering forces are provided solely by one or more energy supplies.

0011 Self tracking steering equipment - A system designed to create a change of steering angle on one or more wheels only when acted upon by forces and/or moments applied through the tire to road contact.

Data Length:	4 bits	
Resolution:	16 states/4 bit, 0 offset	
Data Range:	0 to 15	Operational Range: same as data range
Type:	Status	
Supporting information:		
PGN	61451	

SPN 2926 *Type of Steering Transmission*

Type of Steering Transmission (Ref. ECE Regulation 79 paragraph 2.6)

0000	Purely mechanical steering transmission
0001	Purely hydraulic steering transmission
0010	Purely electric steering transmission
0011	Hybrid steering transmission
0100-1110	Reserved for SAE assignment
1111	Not available

0000 Purely mechanical steering transmission - A steering transmission in which the steering forces are transmitted entirely by mechanical means.

0001 Purely hydraulic steering transmission - A steering transmission in which the steering forces, somewhere in the transmission, are transmitted only by hydraulic means.

0010 Purely electric steering transmission - A steering transmission in which the steering forces, somewhere in the transmission, are transmitted only through electric means.

0011 Hybrid steering transmission - A steering transmission in which part of the steering forces is transmitted through one and the other part through another of the above mentioned means. However, in the case where any mechanical part of the transmission is designed only to give position feedback and is too weak to transmit the total sum of the steering forces, this system shall be considered to be purely hydraulic or purely electric steering transmission.

Data Length:	4 bits	
Resolution:	16 states/4 bit, 0 offset	
Data Range:	0 to 15	Operational Range: same as data range
Type:	Status	
Supporting information:		
PGN	61451	

SPN 2927 *Actual Inner wheel steering angle*

Signal which indicates the actual inner wheel steering angle. See Figure SPN2927_A for explanation of positive and negative angles.

Data Length: 2 bytes
 Resolution: 1/256 deg/bit, -125 deg offset
 Data Range: -125 to 125 deg Operational Range: same as data range
 Type: Measured
 Supporting information: See Appendix D - SPN 2927
 PGN 61451

SPN 2928 *Axle Location*

To identify to which of several similar devices (such as tires or fuel tanks) the information applies.

The low order 4 bits represent a position number, counting left to right when facing in the direction of normal vehicle travel (forward).

The high order 4 bits represent a position number, counting front to back on the vehicle.

The value 0xFF indicates not available.

It is recommended that output devices add 1 to the position number (range 1 to 15, not 0 to 14) for use by drivers and service technicians.

Examples: Tire pressure for location 0x00 would be left front tire.

Tire pressure for location 0x23 would be right outside rear rear on a 3-axle tractor with dual axle per side (3rd axle, 4th tire).

Data Length: 8 bits
 Resolution: 256 states/8 bit, 0 offset
 Data Range: 0 to 255 Operational Range: same as data range
 Type: Measured
 Supporting information:
 PGN 61451

SPN 2930 *Hydraulic Brake System Audible Warning Command*

Signal which commands an audible warning by the hydraulic braking system.

00 Audible warning off
 01 Audible warning on
 10 Reserved
 11 Don't care

Data Length: 2 bits
 Resolution: 4 states/2 bit, 0 offset
 Data Range: 0 to 3 Operational Range: same as data range
 Type: Status
 Supporting information:
 PGN 64998

SPN 2931 Hydraulic Brake Fluid Level Switch

Signal which indicates whether the hydraulic fluid level in the reservoir(s) is sufficient.

00 Fluid level is not sufficient
 01 Fluid level is sufficient
 10 Error indicator
 11 Not available

Data Length: 2 bits
 Resolution: 4 states/2 bit, 0 offset
 Data Range: 0 to 3 Operational Range: same as data range
 Type: Measured
 Supporting information:
 PGN 64998

SPN 2945 Active Shift Console Indicator

Signal from transmission control unit indicating which shift console (primary or secondary) it currently considers as the active shift selector input.

00 Primary shift console is active
 01 Secondary shift console is active
 10 Reserved
 11 Not available

Note: In some applications such as refuse trucks, the transmission can be operated from two positions in the vehicle. The transmission control unit will accept changes in transmission requested gear (SPN 525) from the operator only from the active shift console. The transmission control unit determines which shift console is active based on a switch input controlled by the operator and transmission system state criteria.

Data Length: 2 bits
 Resolution: 4 states/2 bit, 0 offset
 Data Range: 0 to 3 Operational Range: same as data range
 Type: Status
 Supporting information:
 PGN 65098

SPN 2948 Engine Intake Valve Actuation System Oil Pressure

The gage pressure of the oil in the hydraulic system that powers the engine intake valve actuation system

Data Length: 2 bytes
 Resolution: 1/256 MPa/bit, 0 offset
 Data Range: 0 to 251 Mpa Operational Range: same as data range
 Type: Measured
 Supporting information:
 PGN 64961

SPN 2970 Accelerator Pedal 2 Low Idle Switch

Switch signal which indicates the state of the accelerator pedal 2 low idle switch. The low idle switch is defined in SAE J1843.

00 Accelerator pedal 2 not in low idle condition
 01 Accelerator pedal 2 in low idle condition
 10 Error
 11 Not available

Data Length: 2 bits
 Resolution: 4 states/2 bit, 0 offset
 Data Range: 0 to 3 Operational Range: same as data range
 Type: Measured
 Supporting information:
 PGN 61443

SPN 2978 Estimated Engine Parasitic Losses - Percent Torque

The calculated torque that indicates the estimated amount of torque loss due to engine parasitics, such as cooling fan, air compressor, air conditioning, etc. It is expressed as a percent of Engine Reference Torque.

When the data value of this parameter is equal to FB it means that all parasitic losses calculated by the engine are included in the Engine's Nominal Friction Percent Torque (SPN 514).

Data Length: 1 byte
 Resolution: 1 %/bit, -125 % offset
 Data Range: -125 to 125 % Operational Range: 0 to 125%
 Type: Status
 Supporting information:
 PGN 65247

SPN 2979 Vehicle Acceleration Rate Limit Status

Status (active or not active) of the system used to limit maximum forward vehicle acceleration.

00 Limit not active
 01 Limit active
 10 Reserved
 11 Not available

NOTE: The effects of emission control limits, such as engine exhaust smoke control, are specifically excluded; they are not considered to be part of a function to limit vehicle acceleration.

Data Length: 2 bits
 Resolution: 4 states/2 bit, 0 offset
 Data Range: 0 to 3 Operational Range: same as data range
 Type: Status
 Supporting information:
 PGN 61443

SPN 2980 Engine Fuel Valve 1 Outlet Absolute Pressure

Absolute Pressure of gas on outlet side of the first or only fuel system control valve. See SPN 3469 for the second fuel control valve.

Data Length: 2 bytes

Resolution: 0.1 kPa/bit, 0 offset

Data Range: 0 to 6,425.5 kPa Operational Range: same as data range

Type: Measured

Supporting information:

PGN 65163

SPN 2983 Clutch Life Remaining

Signal which indicates the actual clutch life remaining in percent. One hundred percent means the clutch is brand new and zero percent means the clutch is at the end of its life.

Data Length: 1 byte

Resolution: 0.4 %/bit, 0 offset

Data Range: 0 to 100 % Operational Range: same as data range

Type: Measured

Supporting information:

PGN 65195

SPN 2984 Automatic traction help (load transfer)

This signal enables the traction help (load transfer) in case of an active ASR function

00 Disable automatic traction help

01 Enable automatic traction help

10 Reserved

11 Don't care

Data Length: 2 bits

Resolution: 4 states/2 bit, 0 offset

Data Range: 0 to 3 Operational Range: same as data range

Type: Status

Supporting information:

PGN 53760

SPN 2985 *Transmission Shift Selector Display Mode Switch*

Status of the operator's switch used to 'toggle' through multiple display modes of a shift selector display.

When a shift selector display is capable of displaying more than just range information, this switch is toggled by the operator to move through the different display modes. If the selector has only two display modes, this switch may behave as a typical SPST switch. If the selector has more than two display modes, the switch may be momentary, where each activation indicates that the selector has scrolled through to the next subsequent display mode.

00 Off
01 On
10 Error
11 Not available

Data Length: 2 bits
Resolution: 4 states/2 bit, 0 offset
Data Range: 0 to 3 Operational Range: same as data range
Type: Measured
Supporting information:
PGN 256

SPN 2986 *Engine Intake Valve Actuation System Oil Temperature*

The temperature of the oil in the hydraulic system that powers the intake valve actuation system.

Data Length: 2 bytes
Resolution: 0.03125 deg C/bit, -273 deg C offset
Data Range: -273 to 1735 deg C Operational Range: same as data range
Type: Measured
Supporting information:
PGN 65129

SPN 3026 Transmission Oil Level Measurement Status

Indicates if conditions are acceptable to obtain a valid transmission oil level measurement as conveyed in SPN 124 Transmission Oil Level or SPN 3027 Transmission Oil Level High / Low. If conditions are not acceptable, this parameter conveys to the operator what prevents conditions from being acceptable. Only one condition can be conveyed in this parameter at any given point in time. If multiple conditions exist, it is not important which condition is actually broadcast, as the driver must 'correct' each and every condition as it is presented before a valid oil level reading can be made. If multiple conditions exist that prevent a valid reading, the sender should broadcast one of those conditions until it is corrected; then the next condition can be conveyed to the operator, and so on.

0000 Conditions valid for transmission oil level measurement
 0001 Conditions not valid – Settling timer still counting down
 0010 Conditions not valid – Transmission in gear
 0011 Conditions not valid – Transmission fluid temperature too low
 0100 Conditions not valid – Transmission fluid temperature too high
 0101 Conditions not valid – Vehicle moving; output shaft speed too high
 0110 Conditions not valid – Vehicle not level
 0111 Conditions not valid – Engine speed too low
 1000 Conditions not valid – Engine speed too high
 1001 Conditions not valid – No request for reading
 1010 Not defined
 1011 Not defined
 1100 Not defined
 1101 Conditions not valid - Other
 1110 Error
 1111 Not available

Data Length: 4 bits
 Resolution: 16 states/4 bit, 0 offset
 Data Range: 0 to 15 Operational Range: same as data range
 Type: Status
 Supporting information:
 PGN 65272

SPN 3027 Transmission Oil Level High / Low

Amount of current volume of transmission sump oil compared to recommended volume. Positive values indicate overflow. Zero means the transmission fluid is filled to the recommended level.

Parameter Specific Indicator:
 A value of FB hex indicates conditions are not acceptable for a valid fluid level measurement.

Data Length: 1 bytes
 Resolution: 0.5 L/bit, -62.5 L offset
 Data Range: -62.5 to 62.5 L Operational Range: same as data range
 Type: Measured
 Supporting information:
 PGN 65272

SPN 3028 *Transmission Oil Level Countdown Timer*

Once all vehicle conditions (such as vehicle stopped, etc) are met, some transmissions may require a 'settling time' to allow the fluid level to normalize. This parameter indicates how much of the required settling time remains. When time reaches 0, a valid oil level measurement value will be broadcast in SPN 3027 Transmission Oil Level High / Low.

0000 less than 1 minute
 0001 One minute
 0010 Two minutes
 0011 Three minutes
 0100 Four minutes
 0101 Five minutes
 0110 Six minutes
 0111 Seven minutes
 1000 Eight minutes
 1001 Nine minutes
 1010 Ten minutes
 1011 Eleven minutes
 1100 Twelve minutes
 1101 Thirteen minutes
 1110 Error
 1111 Not Available

Data Length: 4 bits
 Resolution: 16 states/4 bit, 0 offset
 Data Range: 0 to 15 Operational Range: 0 to 13 minutes
 Type: Measured
 Supporting information:
 PGN 65272

SPN 3030 *Transmission Torque Converter Ratio*

Ratio of the transmissions torque converter output torque to torque converter input torque at current speed.

The ratio of 1.000 (03 E8 hex) indicates torque converter lockup.
 If the ratio is less than 1 and the ratio can not be properly determined it shall be set to a value of FB00 hex.
 Ratios above 1 indicate torque converter multiplication.

Data Length: 2 bytes
 Resolution: 0.001/bit, 0 offset
 Data Range: 0 to 64.255 Operational Range: same as data range
 Type: Measured
 Supporting information:
 PGN 61452

SPN 3031 *Catalyst Tank Temperature*

Temperature of the reagent in the storage tank.

Data Length: 1 byte
 Resolution: 1 deg C/bit, -40 deg C offset
 Data Range: -40 to 210 deg C Operational Range: same as data range
 Type: Measured
 Supporting information:
 PGN 65110

SPN 3043 Type of Passenger Count

Used to notify transit link devices of the type of passenger counting system used in the vehicle. Some passenger counting systems indicate real-time boarding and exiting data for other devices to accumulate. Other types of passenger counters report a current on-board total relative to a transit door status, a fare collection status, or other signal which can define the end of the boarding/exiting period and a stable underway totalized passenger count.

0 - absolute passenger count
 1 - boarding passenger
 2 - exiting passenger
 3 - boarding passenger (second passenger stream)
 4 - exiting passenger (second passenger stream)
 5 to 250 - reserved for future assignment
 251 to 253 - reserved
 254 - error indicator
 255 - not available

Data Length: 8 bits
 Resolution: 256 states/8 bit, 0 offset
 Data Range: 0 to 255 Operational Range: same as data range
 Type: Measured
 Supporting information:
 PGN 64960

SPN 3044 Silent Alarm Status

Used to report silent alarm push button status.

00 - Off
 01 - On
 10 - Error condition
 11 - Not available

Data Length: 2 bits
 Resolution: 4 states/2 bit, 0 offset
 Data Range: 0 to 3 Operational Range: same as data range
 Type: Status
 Supporting information:
 PGN 64960

SPN 3045 Vehicle Use Status

Used to indicate the proper or unauthorized use of the vehicle. The administrative control device or any device issuing the vehicle use status PID should be sensitive to the run switch status (SPN 3046) and any other locally defined criteria for authorized use (i.e., driver log-ons) before the vehicle use status PID is used to generate an unauthorized use alarm.

00 - Normal use
 01 - Unauthorized use
 10 - Error condition
 11 - Not available

Data Length: 2 bits
 Resolution: 4 states/2 bit, 0 offset
 Data Range: 0 to 3 Operational Range: same as data range
 Type: Status
 Supporting information:
 PGN 64960

SPN 3046 **Transit Run Status**

Status of the run switch for the vehicle.

00 - Off
01 - On
10 - Error condition
11 - Not available

Data Length: 2 bits
Resolution: 4 states/2 bit, 0 offset
Data Range: 0 to 3 Operational Range: same as data range
Type: Status
Supporting information:
PGN 64960

SPN 3047 **Patron Count**

Count of the number of passengers on a transit vehicle. If the type of passenger count (SPN 3043) is 0, the patron count indicates the number of patrons currently on vehicle after the door has closed. If the type of passenger count is 1 to 4, the patron count indicates an incremental count of passengers since the last data transmittal.

Data Length: 1 byte
Resolution: 1 count/bit, 0 offset
Data Range: 0 to 250 Operational Range: same as data range
Type: Measured
Supporting information:
PGN 64960

SPN 3070 **Number of bytes in the Milepost Identification**

Number of bytes in the Milepost Identification

Data Length: 1 byte
Resolution: 1 byte/bit, 0 offset
Data Range: 0 to 250 Operational Range: 0 to 100 bytes
Type: Measured
Supporting information:
PGN 64959

SPN 3071 **Number of bytes in the Transit Assigned Route Identity**

Number of bytes in the Transit Assigned Route Identity

Data Length: 1 byte
Resolution: 1 byte/bit, 0 offset
Data Range: 0 to 250 Operational Range: 1 to 100 bytes
Type: Measured
Supporting information:
PGN 64958

SPN 3072 **Number of bytes in the Transit Assigned Run Identity**

Number of bytes in the Transit Assigned Run Identity

Data Length: 1 byte

Resolution: 1 byte/bit, 0 offset

Data Range: 0 to 250 Operational Range: 1 to 100 bytes

Type: Measured

Supporting information:

PGN 64958

SPN 3073 **Number of bytes in the Transit Assigned Block Identity**

Number of bytes in the Transit Assigned Block Identity

Data Length: 1 byte

Resolution: 1 byte/bit, 0 offset

Data Range: 0 to 250 Operational Range: 1 to 100 bytes

Type: Measured

Supporting information:

PGN 64958

SPN 3074 **Transit Assigned Route Identity**

Identifies the transit route assigned to a specific vehicle

Data Length: Variable - up to 100 characters

Resolution: ASCII, 0 offset

Data Range: 0 to 255 per byte Operational Range: same as data range

Type: Measured

Supporting information:

PGN 64958

SPN 3075 **Transit Assigned Run Identity**

Identifies the transit run assigned to a specific vehicle

Data Length: Variable - up to 100 characters

Resolution: ASCII, 0 offset

Data Range: 0 to 255 per byte Operational Range: same as data range

Type: Measured

Supporting information:

PGN 64958

SPN 3076 **Transit Assigned Block Identity**

Identifies the transit block assigned to a specific vehicle

Data Length: Variable - up to 100 characters

Resolution: ASCII, 0 offset

Data Range: 0 to 255 per byte Operational Range: same as data range

Type: Measured

Supporting information:

PGN 64958

SPN 3078 **Agency**

The identity of the agency involved in this transaction

Data Length: 1 byte

Resolution: 1 count/bit, 0 offset

Data Range: 0 to 255 Operational Range: same as data range

Type: Measured

Supporting information:

PGN 64958

SPN 3079 **Intersection Preemption Request/Response**

Status of the intersection signal preemption

00 - Message is a request directed to the emitter

01 - Message is a response from the emitter

10 - Error condition

11 - Not available

Data Length: 2 bits

Resolution: 4 states/2 bit, 0 offset

Data Range: 0 to 3 Operational Range: same as data range

Type: Measured

Supporting information:

PGN 64957

SPN 3080 **Transit Route ID Usage**

Transit route ID usage

00 - Transit route ID not used for interleaved data

01 - Transit route ID used for interleaved data (if range code not enabled)

10 - Error condition

11 - Not available

Data Length: 2 bits

Resolution: 4 states/2 bit, 0 offset

Data Range: 0 to 3 Operational Range: same as data range

Type: Measured

Supporting information:

PGN 64957

SPN 3081 Range Code Enable

Range code enable

00 - Range code not used for interleaved data
01 - Range code used for interleaved data
10 - Error condition
11 - Not available

Data Length: 2 bits
Resolution: 4 states/2 bit, 0 offset
Data Range: 0 to 3 Operational Range: same as data range
Type: Measured
Supporting information:
PGN 64957

SPN 3082 Strobe Activation Control Status

Strobe activation control status

00 - Deactivate strobe
01 - Activate strobe
10 - Error condition
11 - Not available

Note: Strobe will flash if not overridden by transit door status, strobe is working, and emitter is in the normal mode.

Data Length: 2 bits
Resolution: 4 states/2 bit, 0 offset
Data Range: 0 to 3 Operational Range: same as data range
Type: Measured
Supporting information:
PGN 64957

SPN 3083 Transit Door Enable

Transit door enable

00 - Ignore transit door status
01 - Transit door status will override strobe activation
10 - Error condition
11 - Not available

Data Length: 2 bits
Resolution: 4 states/2 bit, 0 offset
Data Range: 0 to 3 Operational Range: same as data range
Type: Measured
Supporting information:
PGN 64957

SPN 3084 **Priority of Response Sent by Emitter**

Priority of response sent by emitter

0000 - Reserved
 0001 - Low priority
 0010 - Probe priority
 0011 - High priority
 0100 to 1000 - Reserved
 1001 - Priority set by hardware to low priority
 1010 - Priority set by hardware to probe priority
 1011 - Priority set by hardware to high priority
 1100 to 1101 - Reserved
 1110 - Error condition
 1111 - Not available

Data Length: 4 bits
 Resolution: 16 states/4 bit, 0 offset
 Data Range: 0 to 15 Operational Range: same as data range
 Type: Measured
 Supporting information:
 PGN 64957

SPN 3085 **Vehicle ID**

Numerical designation of the vehicle. 65535 is used to represent the vehicle ID is not available.

Data Length: 2 bytes
 Resolution: 1 count/bit, 0 offset
 Data Range: 0 to 65,535 counts Operational Range: 0 to 65,534
 Type: Measured
 Supporting information:
 PGN 64957

SPN 3086 **Transmission Ready for Brake Release**

This parameter indicates that enough torque / motive force is available at the transmission output shaft to release all the brakes without a risk of unintentional movement in the opposite direction.

00 - Transmission Not Ready for Brake Release
 01 - Transmission Ready for Brake Release
 10 - Reserved
 11 - Don't Care

Data Length: 2 bits
 Resolution: 4 states/2 bit, 0 offset
 Data Range: 0 to 3 Operational Range: same as data range
 Type: Status
 Supporting information:
 PGN 65098

SPN 3087 Auxiliary Level

Level measured by a sensor.

Data Length: 2 bytes

Resolution: 0.1 mm/bit, 0 offset

Data Range: 0 to 6,425.5 mm (0 to

Operational Range: same as data range

Type: Measured

Supporting information:

PGN 65164

SPN 3156 Blade Control Mode Switch

This parameter indicates the blade control mode switch state the user has set for the land leveling system. The switch value directly correlates to the current switch state, regardless of the switch being used. This parameter is intended for use in systems using only one parameter to control the blade movement (i.e. elevation). Systems using two independent parameters to control blade position, i.e. one blade edge maintains a constant elevation and the other blade edge maintains a constant blade angle, should use parameters specific to that usage. Only one of the following states will be active at a time. Below are the data values defined for each switch type that may be used in this application. The purpose of the following switch information is to define what data should be reported based on what type of switch is used.

1. A toggle button with two states can be used, in which the button is either in the manual or the auto position at all times.

Toggle button usage is as follows:

Manual Position = 0010 Manual button pressed
Auto Position = 0011 Automatic button pressed

2. The momentary rocker switch may be used, where the default is the no button pressed position. The user can press the rocker into the manual position, and when pressure is released, it will return to the no button pressed position. The user may also press the rocker into the auto position, and when pressure is released, it will return to the no button pressed position. Momentary rocker button usage is as follows:

No Button Pressed = 0000 No button pressed
Manual Button Pressed = 0010 Manual button pressed
Auto Button Pressed = 0011 Automatic button pressed

3. The momentary contact button pair may be used, where the default is no buttons being pressed. The user can press the manual button, and when pressure is released, it will return to the no button pressed position. The user may press the auto button, and when pressure is released, it will return to the no button pressed position. Momentary contact buttons (button pair) usage is as follows:

No Button Pressed = 0000 No button pressed
Manual Button Pressed = 0010 Manual button pressed
Auto Button Pressed = 0011 Automatic button pressed

4. The momentary contact single button may be used, where the default is no button being pressed. The user can press the button, which is the button pressed position, and when pressure is released, it will return to the no button pressed position. The controller receiving this command will keep track of what mode the blade is in, auto or manual. When the button is pressed, the "mode button pressed" state is reported and the receiving controller then changes the current mode to its opposite value (i.e. manual to automatic or vice-versa). Momentary contact button (single button) usage is as follows:

No Button Pressed = 0000 No button pressed
Button Pressed = 0001 Mode button pressed

Data Values and Descriptions:

0000 No button pressed
0001 Mode button pressed
0010 Manual button pressed
0011 Automatic button pressed
1110 Error Indicator
1111 Not Installed
All other values are reserved

Notes:

1. The switch state can be read in two ways. One method uses the direct analog switch input to determine the switch state, while the second method relies on a secondary control to read the analog input, then relay the information on the data link. The parameter is designed to provide the actual switch state to other controls that need the information.
2. Other systems with automated blade controls should be able to use this parameter, since it is a measured switch value.

Data Length: 4 bits
Resolution: 16 states/4 bit, 0 offset
Data Range: 0 to 15 Operational Range: same as data range
Type: Measured
Supporting information:
PGN 61453

SPN 3157 *Desired Grade Offset Switch*

This parameter indicates the grade offset switch state the user has set for the land leveling system. The desired grade offset value is the vertical offset measured from a given elevation reference point to the bottom edge of the blade. This parameter is intended for use in systems using only elevation offset to control the blade movement (i.e. elevation). Systems using two independent parameters to control blade position, i.e. one edge maintains a constant elevation and the other blade edge maintains a constant angle, should use parameters specific to that usage. Only one of the following states will be active at a time. Below are the data values defined for each switch type that may be used in this application. The purpose of the following switch information is to define what data should be reported based on what type of switch is used.

1. The momentary rocker switch may be used, where the default is the no button pressed position. The user can press the rocker into the increment button pressed position, and when pressure is released, it will return to the no button pressed position. The user may also press the rocker into the decrement button pressed position, and when pressure is released, it will return to the no button pressed position. Momentary rocker button usage is as follows:

No Button Pressed = 0000 No button pressed
 Increment Button Pressed = 0001 Increment button pressed
 Decrement Button Pressed = 0010 Decrement button pressed

2. The momentary contact button pair may be used, where the default is the no buttons pressed position. The user can press the increment button, and when pressure is released, it will return to the no buttons pressed position. The user may press the decrement button, and when pressure is released, it will return to the no buttons pressed position. Momentary contact button (button pair) usage is as follows:

No Button Pressed = 0000 No button pressed
 Increment Button Pressed = 0001 Increment button pressed
 Decrement Button Pressed = 0010 Decrement button pressed

Data Values and Descriptions:

0000 No button pressed
 0001 Increment button pressed
 0010 Decrement button pressed
 1110 Error Indicator
 1111 Not installed
 All other values are reserved

Notes:

1. The switch state can be read in two ways. One method uses the direct analog switch input to determine the switch state, while the second method relies on a secondary control to read the analog input, then relay the information on the data link. The parameter is designed to provide the actual switch state to other controls that need the information.
2. Other systems with automated blade controls should be able to use this parameter, since it is a measured switch value.

Data Length: 4 bits
 Resolution: 16 states/4 bit, 0 offset
 Data Range: 0 to 15 Operational Range: same as data range
 Type: Measured
 Supporting information:
 PGN 61453

SPN 3158 Blade Auto Mode Command

Allows other controllers to command to the primary control system what they think is the appropriate auto control mode to be engaged in, based on the information they have available to them. When in automatic mode, the blade automatically adjusts its position to the center of the blade to maintain a desired grade offset. Only one of the following states will be active at a time. Below is extended information describing each command. The purpose of this information is to define what command state should be reported based on what auto control mode command is deemed appropriate by the operational specifications of the system.

0000 Auto Allowed - Auto mode permitted as appropriate (auto button was pushed or directly returned from Suspend Auto condition)

0001 Activity Allows Auto - Auto mode permitted only if the primary control system detects operator activity. The control issuing this command does not have sufficient information/reason to absolutely allow Auto mode (state 0000) or not allow Auto mode (state 0100). The control issuing this command is permitting the primary control system to operate in auto mode only if the primary control system detects operator activity, such as direct input to the primary control system.

If the primary control system does not detect operator activity, then the control issuing this command is not allowing auto mode. For example, the control issuing this command has detected no operator activity yet it acknowledges that there may be other sources of operator activity that might make auto mode permissible.

0010 Suspend Auto - Auto mode is temporarily not allowed and the control issuing this command wants the primary control system to automatically return to the previous state (Auto or Manual) when the suspend auto condition is removed.

0011 Service Mode - Auto mode is permitted only for special services such as calibrations.

0100 Auto Not Allowed - Auto mode is not allowed under any condition

Data Values and Descriptions:

0000 Auto Allowed

0001 Activity Allows Auto - must detect operator before auto allowed

0010 Suspend Auto - temporarily suspend auto mode

0011 Service Mode - auto allowed only during service modes

0100 Auto Not Allowed

1110 Error Indicator

1111 Not Supported

All other values are reserved

Note:

The control issuing this command is aware that it does not have access to all information that the primary controller of the Land Leveling System attachment has access to. Therefore, it commands the Land Leveling system to activate a auto blade mode based on the input it has access to. In some cases, like in the "Activity Allows Auto" situation, the control knows the Land Leveling system has access to an additional display (which has switches and several buttons) which may help determine if an operator is present. On the other hand, the control may also have information the primary controller of the Land Leveling System does not have access to, like the parking brake status.

Data Length: 4 bits

Resolution: 16 states/4 bit, 0 offset

Data Range: 0 to 15

Operational Range: same as data range

Type: Status

Supporting information:

PGN 61453

SPN 3159 Trip Number

The identity number assigned to this trip.

Data Length: 2 bytes

Resolution: 1 count/bit, 0 offset

Data Range: 0 to 65,535 counts

Operational Range: same as data range

Type: Measured

Supporting information:

PGN 64956

SPN 3160 Assigned Route

The identity number assigned to this route.

Note: This is the numerical value for the route as opposed to the "Transit Assigned Route Identity" (SPN 3074) which is variable length ASCII or the "Route number" (SPN 3169) which is 12 bit numeric.

Data Length: 2 bytes
Resolution: 1 count/bit, 0 offset
Data Range: 0 to 65,535 counts Operational Range: same as data range
Type: Measured
Supporting information:
PGN 64956

SPN 3161 Pattern Number

The agency defined pattern number for this trip

Data Length: 2 bytes
Resolution: 1 count/bit, 0 offset
Data Range: 0 to 65,535 counts Operational Range: same as data range
Type: Measured
Supporting information:
PGN 64956

SPN 3162 Assigned Run

The agency defined run number for this trip

Data Length: 2 bytes
Resolution: 1 count/bit, 0 offset
Data Range: 0 to 65,535 counts Operational Range: same as data range
Type: Measured
Supporting information:
PGN 64956

SPN 3163 Assigned Block

The agency defined block number for this trip

Data Length: 2 bytes
Resolution: 1 count/bit, 0 offset
Data Range: 0 to 65,535 counts Operational Range: same as data range
Type: Measured
Supporting information:
PGN 64956

SPN 3164 *Driver's farebox security code*

Security code for the farebox, numerical only.

Note: 0 = Farebox is in reporting status
1 - 65535 = security code

Data Length: 2 bytes
Resolution: 1 count/bit, 0 offset
Data Range: 0 to 65,535 counts Operational Range: same as data range
Type: Measured
Supporting information:
PGN 64956

SPN 3165 *Fare Validity*

Agency defined value indicating validity of this fare

Data Length: 4 bits
Resolution: 1 count/bit, 0 offset
Data Range: 0 to 15 Operational Range: same as data range
Type: Measured
Supporting information:
PGN 64955

SPN 3166 *Pass Category*

Agency defined value indicating the category of the passenger associated with this fare

Data Length: 4 bits
Resolution: 1 count/bit, 0 offset
Data Range: 0 to 15 Operational Range: same as data range
Type: Measured
Supporting information:
PGN 64955

SPN 3167 *Initial Fare Agency*

Identifies where the initial fare is paid

Note: The definition of the agency numbering plan shall be agreed by the operating agency and the farebox manufacturer.
The value of 0 is reserved, the usable range is 1 to 31.

Data Length: 5 bits
Resolution: 1 count/bit, 0 offset
Data Range: 0 to 31 Operational Range: 1 to 31
Type: Measured
Supporting information:
PGN 64955

SPN 3168 Transfer Sold

Indicates that a transfer was sold or issued on this transaction including its type and/or restrictions. The final definitions of the transfer issued information shall be agreed by the operating agency and the farebox manufacturer.

Note: A non-zero value indicates that a transfer was sold or issued. The value of zero is reserved to indicate that no transfer has been sold or issued.

Data Length: 1 byte
Resolution: 1 count/bit, 0 offset
Data Range: 0 to 255 Operational Range: same as data range
Type: Measured
Supporting information:
PGN 64955

SPN 3169 Route Number

The route number issuing the transfer.

Data Length: 12 bits
Resolution: 1 count/bit, 0 offset
Data Range: 0 to 4095 Operational Range: same as data range
Type: Measured
Supporting information:
PGN 64955

SPN 3170 Transaction Type

Enumerated value representing the type of transaction completed

0000 = Cash
0001 = Token
0010 = Ticket
0011 = Pass
0100 = Card
0101 = Permit
0110 = Transfer
0111 = Free
1000-1011 = Reserved for assignment
1100-1111 = Agency defined

Data Length: 4 bits
Resolution: 16 states/4 bit, 0 offset
Data Range: 0 to 15 Operational Range: same as data range
Type: Measured
Supporting information:
PGN 64955

SPN 3171 **Passenger Type**

Enumerated value representing the type/class of passenger, as defined by the agency.

Data Length: 4 bits
Resolution: 16 states/4 bit, 0 offset
Data Range: 0 to 15 Operational Range: same as data range
Type: Measured
Supporting information:
PGN 64955

SPN 3172 **Type of Service**

The type of service provided

000 = Local service
001 = Express service
010-111 = Agency defined
Data Length: 3 bits
Resolution: 8 states/3 bit, 0 offset
Data Range: 0 to 7 Operational Range: same as data range
Type: Measured
Supporting information:
PGN 64955

SPN 3173 **Transfer Type**

The kind of transfer used

00000 = North
00001 = South
00010 = East
00011 = West
00100 = In
00101 = Out
00110-11111 = Agency defined
Data Length: 5 bits
Resolution: 32 states/5 bit, 0 offset
Data Range: 0 to 31 Operational Range: same as data range
Type: Measured
Supporting information:
PGN 64955

SPN 3174 ***Trip Direction***

The general direction of travel for this trip.

0000 = North
 0001 = South
 0010 = East
 0011 = West
 0100 = In
 0101 = Out
 0110-1111 = Agency defined

Data Length: 4 bits
 Resolution: 16 states/4 bit, 0 offset
 Data Range: 0 to 15 Operational Range: same as data range
 Type: Measured
 Supporting information:
 PGN 64956

SPN 3175 ***Fare Presets***

Fare Presets

00000000 to 00001111 = Agency defined
 00010000 to 11111111 = Reserved for assignment

Data Length: 8 bits
 Resolution: 256 states/8 bit, 0 offset
 Data Range: 0 to 255 Operational Range: same as data range
 Type: Measured
 Supporting information:
 PGN 64956

SPN 3176 ***Type of Fare***

Type of Fare

0000 = Cash/No detail
 0001 = Token A
 0010 = Token B
 0011 = Ticket A
 0100 = Ticket B
 0101 = Pass A
 0110 = Pass B
 0111-1010 = Reserved for assignment
 1011-1111 = Agency defined

Data Length: 4 bits
 Resolution: 16 states/4 bit, 0 offset
 Data Range: 0 to 15 Operational Range: same as data range
 Type: Measured
 Supporting information:
 PGN 64955

SPN 3177 **Payment Details**

Payment details.

0000 = Not an upgrade
0001 = Cash
0010 = Token
0011 = Ticket
0100 = Pass
0101 = Card
0110-1010 = Reserved for assignment
1011-1111 = Agency defined

Data Length: 4 bits
Resolution: 16 states/4 bit, 0 offset
Data Range: 0 to 15 Operational Range: same as data range
Type: Measured
Supporting information:
PGN 64955

SPN 3178 **Farebox Service Status**

Indicates if the farebox is in or out of service.

00 = Farebox out of service
01 = Farebox in service
10 = Error Condition
11 = Not available

Data Length: 2 bits
Resolution: 4 states/2 bit, 0 offset
Data Range: 0 to 3 Operational Range: same as data range
Type: Measured
Supporting information:
PGN 64956

SPN 3179 **Farebox Emergency Status**

Indicates if a farebox emergency condition exists.

00 = Non-emergency condition
01 = Emergency condition
10 = Error Condition
11 = Not available

Data Length: 2 bits
Resolution: 4 states/2 bit, 0 offset
Data Range: 0 to 3 Operational Range: same as data range
Type: Measured
Supporting information:
PGN 64954

SPN 3180 Trip Status

Trip Status

000 = Undefined
 001 = Trip start
 010 = Trip end
 011 = Undefined
 100 = Undefined
 101 = Layover start
 110 = Layover end
 111 = Undefined

Data Length: 3 bits
 Resolution: 8 states/3 bit, 0 offset
 Data Range: 0 to 7 Operational Range: same as data range
 Type: Measured
 Supporting information:
 PGN 64956

SPN 3181 Farebox Alarm Identifier

Indicates the nature of the farebox alarm condition.

0000000 = Voltage dropout
 0000001 = Voltage restored
 0000010 = Probe started
 0000011 = Probe completed
 0000100 = Cashbox removed
 0000101 = Cashbox restored
 0000110 = Cashbox door timeout
 0000111 = Cashbox opened in service, considered an alarm condition
 0001000 = Insufficient fare accepted
 0001001 = Coinbox 75% full
 0001010 = Coinbox full
 0001011 = Currency box 75% full
 0001100 = Currency box less than 75% full
 0001101 = Currency box full
 0001110 = Card/pass box 75% full
 0001111 = Card/pass box less than 75% full
 0010000 = Card/pass box full
 0010001 = Coin de-jam operated
 0010010 = Farebox set in manual bypass
 0010011 = Farebox reset to automatic mode
 0010100 = Pass/transfer jam
 0010101 = Pass/transfer jam cleared
 0010110 = Paper currency jam
 0010111 = Paper currency jam cleared
 0011000 = Maintenance access in service, considered an alarm condition
 0011001 = Maintenance access out of service
 0011010-1100000 = Reserved - to be assigned
 1100001-1111111 = Agency defined

Data Length: 7 bits
 Resolution: 128 states/7 bit, 0 offset
 Data Range: 0 to 127 Operational Range: same as data range
 Type: Measured
 Supporting information:
 PGN 64954

SPN 3188 XBR Message Checksum

The XBR message checksum is used to verify the signal path from the demanding device to the brake controller on electronic brake systems. The support of this parameter is mandatory if PGN 1024 is supported as there is no means to indicate "not available".

The 4 bit checksum is the sum of the high nibble and the low nibble of the sum of the identifier, the first 7 data bytes and the 4 bit message counter. It is calculated as follows:

Checksum = (Byte1 + Byte2 + Byte3 + Byte4 + Byte5 + Byte6 + Byte7 + message counter & 0x0F + message ID low byte + message ID mid low byte + message ID mid high byte + message ID high byte)

Checksum = ((Checksum >> 4) + Checksum) & 0x0F

Note: A failure in the communication sets the XBR system state:

- to '01' for failed XBR 'priority 01, 10 or 11' messages
- to '10' for failed XBR 'priority 00' messages.

Data Length: 4 bits
Resolution: 1 count/bit, 0 offset
Data Range: 0 to 15 Operational Range: same as data range
Type: Status
Supporting information:
PGN 1024

SPN 3189 XBR Message Counter

The XBR message counter is to verify the signal path from the demanding device to the brake controller on electronic brake systems. The support of this parameter is mandatory.

Note: The initial value of the 4 bit message counter for the first message during a driving cycle is arbitrary. In every following message the counter is incremented by 1 (0 follows 15).

Data Length: 4 bits
Resolution: 1 count/bit, 0 offset
Data Range: 0 to 15 Operational Range: same as data range
Type: Status
Supporting information:
PGN 1024

SPN 3190 *Tire Location*

Identifies which tire is associated with the parametric data in this PGN.

The low order 4 bits represent a position number, counting left to right when facing in the direction of normal vehicle travel (forward).

The high order 4 bits represent a position number, counting front to back on the vehicle.

The value 0xFF indicates not available.

It is recommended that output devices add 1 to the position number (range 1 to 15, not 0 to 14) for use by drivers and service technicians.

Examples: Tire pressure for location 0x00 would be left front tire.

Tire pressure for location 0x23 would be right outside rear rear on a 3-axle tractor with dual axle per side (3rd axle, 4th tire).

Data Length: 8 bits
 Resolution: 256 states/8 bit, 0 offset
 Data Range: 0 to 255 Operational Range: same as data range
 Type: Measured
 Supporting information:
 PGN 64953

SPN 3191 *Reference Tire Pressure*

Reference value of the tire pressure as basis for the tire pressure monitoring

Data Length: 1 byte
 Resolution: 8 kPa/bit, 0 offset
 Data Range: 0 to 2,000 kPa Operational Range: same as data range
 Type: Status
 Supporting information:
 PGN 64953

SPN 3192 *Tire Location*

Identifies which tire is associated with the parametric data in this PGN.

The low order 4 bits represent a position number, counting left to right when facing in the direction of normal vehicle travel (forward).

The high order 4 bits represent a position number, counting front to back on the vehicle.

The value 0xFF indicates not available.

It is recommended that output devices add 1 to the position number (range 1 to 15, not 0 to 14) for use by drivers and service technicians.

Examples: Tire pressure for location 0x00 would be left front tire.

Tire pressure for location 0x23 would be right outside rear rear on a 3-axle tractor with dual axle per side (3rd axle, 4th tire).

Data Length: 8 bits
 Resolution: 256 states/8 bit, 0 offset
 Data Range: 0 to 255 Operational Range: same as data range
 Type: Measured
 Supporting information:
 PGN 44544

SPN 3193 Reference Tire Pressure Setting

Reference value of the tire pressure setting as basis for the tire pressure monitoring

Data Length: 1 byte

Resolution: 8 kPa/bit, 0 offset

Data Range: 0 to 2,000 kPa Operational Range: same as data range

Type: Status

Supporting information:

PGN 44544

SPN 3215 Prohibit air suspension control

This parameter is an external request to the air suspension control system to prohibit all air suspension control. If the request is accepted, response intended to be sent in ASC1 (additional status requested in ASC1), there will be no control either for height changes or axle load distribution changes, i.e. hold current pressures in all suspension devices.

00 No request

01 Request prohibit air suspension control

10 Error indicator

11 Not available

Data Length: 2 bits

Resolution: 4 states/2 bit, 0 offset

Data Range: 0 to 3 Operational Range: same as data range

Type: Status

Supporting information:

PGN 53760

SPN 3216 Aftertreatment 1 Intake NOx

The amount of combined NO and NO₂ in the exhaust entering the aftertreatment system measured by a NO_x sensor at the aftertreatment intake, represented in NO_x molecule parts per million non-NO_x molecules in exhaust bank 1.

Data Length: 2 bytes

Resolution: 0.05 ppm/bit, -200 ppm offset

Data Range: -200 to 3012.75 ppm Operational Range: same as data range

Type: Measured

Supporting information:

PGN 61454

SPN 3217 (R) Aftertreatment 1 Intake %O2

The actual oxidation factor (%O2) of the gas within the exhaust stream. For positive values, the parameter represents the percent oxygen in excess of the amount required for stoichiometric combustion. For negative values, the parameter is proportional to the amount of oxygen being pumped by the sensor. This value is measured by a sensor at the aftertreatment intake in exhaust bank 1.

A value of -12% (0x0000) indicates rich, a value of 21% (0xFAFF) indicates lean. These data points could optionally be used with switching O2 sensors to indicate those states as alternatives to broadcasting the threshold %O2 values. Diagnostic Tools could change display to use the text "Rich" or "Lean" in place of the implied %O2 values which would also be acceptable for display.

Data Length: 2 bytes
 Resolution: 0.000514 %/bit, -12 % offset
 Data Range: -12% to 21% Operational Range: same as data range
 Type: Measured
 Supporting information:
 PGN 61454

SPN 3218 Aftertreatment 1 Intake Gas Sensor Power In Range

Indicates that the power supplied to the aftertreatment intake gas sensor, either NOx or O2, is within the manufacturer's specification in exhaust bank 1.

00 - Not in range
 01 - In range
 10 - Error
 11 - Not available

Data Length: 2 bits
 Resolution: 4 states/2 bit, 0 offset
 Data Range: 0 to 3 Operational Range: same as data range
 Type: Status
 Supporting information:
 PGN 61454

SPN 3219 Aftertreatment 1 Intake Gas Sensor at Temperature

Indicates that the heater element of the aftertreatment intake gas sensor, either NOx or O2, is within the manufacturer's specified range for accurate measurements in exhaust bank 1.

Data Length: 2 bits
 Resolution: 4 states/2 bit, 0 offset
 Data Range: 0 to 3 Operational Range: same as data range
 Type: Status
 Supporting information:
 PGN 61454

SPN 3220 *Aftertreatment 1 Intake NOx Reading Stable*

Indicates that the NOx reading of the aftertreatment intake NOx sensor is stable as determined by the manufacturer's control software in exhaust bank 1.

00 - Not stable
01 - Stable
10 - Error
11 - Not available

Data Length: 2 bits
Resolution: 4 states/2 bit, 0 offset
Data Range: 0 to 3 Operational Range: same as data range
Type: Status
Supporting information:
PGN 61454

SPN 3221 *Aftertreatment 1 Intake Wide-Range % O2 Reading Stable*

Indicates that the %O2 reading of the aftertreatment intake gas sensor, either NOx or O2, is stable as determined by the manufacturer's control software in exhaust bank 1.

00 - Not stable
01 - Stable
10 - Error
11 - Not available

Data Length: 2 bits
Resolution: 4 states/2 bit, 0 offset
Data Range: 0 to 3 Operational Range: same as data range
Type: Status
Supporting information:
PGN 61454

SPN 3222 *Aftertreatment 1 Intake Gas Sensor Heater Preliminary FMI*

Used to identify the applicable J1939-73 FMI detected in the heater of the intake exhaust gas sensor, either NOx or O2, by the manufacturer's sensor control software in exhaust bank 1. When there is no failure FMI 31 is sent. In the case of multiple failures the most severe is communicated.

Data Length: 5 bits
Resolution: Binary, 0 offset
Data Range: 0 to 31 Operational Range: same as data range
Type: Status
Supporting information:
PGN 61454

SPN 3227 (R) Aftertreatment 1 Outlet %O2

The actual oxidation factor (%O2) of the gas within the exhaust stream. For positive values, the parameter represents the percent oxygen in excess of the amount required for stoichiometric combustion. For negative values, the parameter is proportional to the amount of oxygen being pumped by the sensor. This value is measured by a sensor at the aftertreatment outlet in exhaust bank 1.

A value of -12% (0x0000) indicates rich, a value of 21% (0xFAFF) indicates lean. These data points could optionally be used with switching O2 sensors to indicate those states as alternatives to broadcasting the threshold %O2 values. Diagnostic Tools could change display to use the text "Rich" or "Lean" in place of the implied %O2 values which would also be acceptable for display.

Data Length: 2 bytes
Resolution: 0.000514 %/bit, -12 % offset
Data Range: -12% to 21% Operational Range: same as data range
Type: Measured
Supporting information:
PGN 61455

SPN 3228 Aftertreatment 1 Outlet Gas Sensor Power In Range

Indicates that the power supplied to the aftertreatment outlet gas sensor, either NOx or O2, is within the manufacturer's specification in exhaust bank 1.

00 - Not in range
01 - In range
10 - Error
11 - Not available

Data Length: 2 bits
Resolution: 4 states/2 bit, 0 offset
Data Range: 0 to 3 Operational Range: same as data range
Type: Status
Supporting information:
PGN 61455

SPN 3229 Aftertreatment 1 Outlet Gas Sensor at Temperature

Indicates that the heater element of the aftertreatment outlet gas sensor, either NOx or O2, is within the manufacturer's specified range for accurate measurements in exhaust bank 1.

00 - Not in range
01 - In range
10 - Error
11 - Not available

Data Length: 2 bits
Resolution: 4 states/2 bit, 0 offset
Data Range: 0 to 3 Operational Range: same as data range
Type: Status
Supporting information:
PGN 61455

SPN 3230 *Aftertreatment 1 Outlet NOx Reading Stable*

Indicates that the NOx reading of the aftertreatment outlet NOx sensor is stable as determined by the manufacturer's control software in exhaust bank 1.

00 - Not stable
01 - Stable
10 - Error
11 - Not available

Data Length: 2 bits
Resolution: 4 states/2 bit, 0 offset
Data Range: 0 to 3 Operational Range: same as data range
Type: Status
Supporting information:
PGN 61455

SPN 3231 *Aftertreatment 1 Outlet Wide-Range %O2 Reading Stable*

Indicates that the %O2 reading of the aftertreatment outlet gas sensor, either NOx or O2, is stable as determined by the manufacturer's control software in exhaust bank 1.

00 - Not stable
01 - Stable
10 - Error
11 - Not available

Data Length: 2 bits
Resolution: 4 states/2 bit, 0 offset
Data Range: 0 to 3 Operational Range: same as data range
Type: Status
Supporting information:
PGN 61455

SPN 3232 *Aftertreatment 1 Outlet Gas Sensor Heater Preliminary FMI*

Used to identify the applicable J1939-73 FMI detected in the heater of the outlet exhaust gas sensor, either NOx or O2, by the manufacturer's sensor control software in exhaust bank 1. When there is no failure FMI 31 is sent. In the case of multiple failures the most severe is communicated.

Data Length: 5 bits
Resolution: Binary, 0 offset
Data Range: 0 to 31 Operational Range: same as data range
Type: Status
Supporting information:
PGN 61455

SPN 3233 *Aftertreatment 1 Outlet Gas Sensor Heater Control*

Indicates the heater status in the warm-up process. Upon receiving a power-up command, the gas sensor ramps up according to a manufacturer defined profile. The Preheat 1, Preheat 2, and Automatic messages are regions within this profile in exhaust bank 1.

00 - Automatic
01 - Preheat 2
10 - Preheat 1
11 - Heater off

Data Length: 2 bits
Resolution: 4 states/2 bit, 0 offset
Data Range: 0 to 3 Operational Range: same as data range
Type: Status
Supporting information:
PGN 61455

SPN 3234 *Aftertreatment 1 Outlet NOx Sensor Preliminary FMI*

Used to identify the applicable J1939-73 FMI detected in the aftertreatment outlet NOx sensor by the manufacturer's sensor control software in exhaust bank 1. When there is no failure FMI 31 is sent. In the case of multiple failures the most severe is communicated.

Data Length: 5 bits
Resolution: Binary, 0 offset
Data Range: 0 to 31 Operational Range: same as data range
Type: Status
Supporting information:
PGN 61455

SPN 3235 *Aftertreatment 1 Outlet Oxygen Sensor Preliminary FMI*

Used to identify the applicable J1939-73 FMI detected in the aftertreatment outlet oxygen sensor by the manufacturer's sensor control software in exhaust bank 1. When there is no failure FMI 31 is sent. In the case of multiple failures the most severe is communicated.

Data Length: 5 bits
Resolution: Binary, 0 offset
Data Range: 0 to 31 Operational Range: same as data range
Type: Status
Supporting information:
PGN 61455

SPN 3236 *Aftertreatment 1 Exhaust Gas Mass Flow*

Measured/calculated exhaust gas mass upstream of the aftertreatment system in exhaust bank 1 and 2.

Data Length: 2 bytes
Resolution: 0.2 kg/h per bit, 0 offset
Data Range: 0 to 12851 kg/h per bit Operational Range: same as data range
Type: Measured
Supporting information:
PGN 65247

SPN 3237 *Aftertreatment 1 Intake Dew Point*

Indicates that the temperature on the intake side of the aftertreatment system has exceeded the dew point, as estimated by the ECM in exhaust bank 1.

00 - Not exceeded the dew point
01 - Exceeded the dew point
10 - Error
11 - Not available

Data Length: 2 bits
Resolution: 4 states/2 bit, 0 offset
Data Range: 0 to 3 Operational Range: same as data range
Type: Status
Supporting information:
PGN 65247

SPN 3238 *Aftertreatment 1 Exhaust Dew Point*

Indicates that the temperature on the exhaust side of the aftertreatment has exceeded the dew point, as estimated by the ECM in exhaust bank 1.

00 - Not exceeded the dew point
01 - Exceeded the dew point
10 - Error
11 - Not available

Data Length: 2 bits
Resolution: 4 states/2 bit, 0 offset
Data Range: 0 to 3 Operational Range: same as data range
Type: Status
Supporting information:
PGN 65247

SPN 3239 *Aftertreatment 2 Intake Dew Point*

Indicates that the temperature on the intake side of the aftertreatment system has exceeded the dew point, as estimated by the ECM in exhaust bank 2.

00 - Not exceeded the dew point
01 - Exceeded the dew point
10 - Error
11 - Not available

Data Length: 2 bits
Resolution: 4 states/2 bit, 0 offset
Data Range: 0 to 3 Operational Range: same as data range
Type: Status
Supporting information:
PGN 65247

SPN 3240 *Aftertreatment 2 Exhaust Dew Point*

Indicates that the temperature on the exhaust side of the aftertreatment has exceeded the dew point, as estimated by the ECM in exhaust bank 2.

00 - Not exceeded the dew point
01 - Exceeded the dew point
10 - Error
11 - Not available

Data Length: 2 bits
Resolution: 4 states/2 bit, 0 offset
Data Range: 0 to 3 Operational Range: same as data range
Type: Status
Supporting information:
PGN 65247

SPN 3241 *Aftertreatment 1 Exhaust Gas Temperature 1*

The reading from the exhaust gas temperature sensor located farthest upstream in the aftertreatment system in exhaust bank 1.

Data Length: 2 bytes
Resolution: 0.03125 deg C/bit, -273 deg C offset
Data Range: -273 to 1735 deg C Operational Range: same as data range
Type: Measured
Supporting information:
PGN 64948

SPN 3242 (R) *Aftertreatment 1 Diesel Particulate Filter Intake Gas Temperature*

Temperature of engine combustion byproducts entering the diesel particulate filter in exhaust bank 1.

Data Length: 2 bytes
Resolution: 0.03125 deg C/bit, -273 deg C offset
Data Range: -273 to 1735 deg C Operational Range: same as data range
Type: Measured
Supporting information:
PGN 64948

SPN 3243 *Aftertreatment 1 Exhaust Gas Temperature 1 Preliminary FMI*

Used to identify the applicable J1939-73 FMI detected in the exhaust gas temperature 1 sensor by the manufacturer's sensor control software in exhaust bank 1. When there is no failure FMI 31 is sent. In the case of multiple failures the most severe is communicated.

Data Length: 5 bits
Resolution: Binary, 0 offset
Data Range: 0 to 31 Operational Range: same as data range
Type: Status
Supporting information:
PGN 64948

SPN 3244 (R) Aftertreatment 1 Diesel Particulate Filter Intake Gas Temperature Preliminary FMI

Used to identify the applicable J1939-73 FMI detected in the diesel particulate filter intake gas temperature sensor by the manufacturer's sensor control software in exhaust bank 1. When there is no failure FMI 31 is sent. In the case of multiple failures the most severe is communicated.

Data Length: 5 bits
 Resolution: Binary, 0 offset
 Data Range: 0 to 31 Operational Range: same as data range
 Type: Status
 Supporting information:
 PGN 64948

SPN 3245 Aftertreatment 1 Exhaust Gas Temperature 3

The reading from the exhaust gas temperature sensor located farthest downstream in the aftertreatment system in exhaust bank 1.

Data Length: 2 bytes
 Resolution: 0.03125 deg C/bit, -273 deg C offset
 Data Range: -273 to 1735 deg C Operational Range: same as data range
 Type: Measured
 Supporting information:
 PGN 64947

SPN 3246 (R) Aftertreatment 1 Diesel Particulate Filter Outlet Gas Temperature

Temperature of engine combustion byproducts leaving the diesel particulate filter exhaust in exhaust bank 1.

Data Length: 2 bytes
 Resolution: 0.03125 deg C/bit, -273 deg C offset
 Data Range: -273 to 1735 deg C Operational Range: same as data range
 Type: Measured
 Supporting information:
 PGN 64947

SPN 3247 Aftertreatment 1 Exhaust Gas Temperature 3 Preliminary FMI

Used to identify the applicable J1939-73 FMI detected in the exhaust gas temperature 3 sensor by the manufacturer's sensor control software in exhaust bank 1. When there is no failure FMI 31 is sent. In the case of multiple failures the most severe is communicated.

Data Length: 5 bits
 Resolution: Binary, 0 offset
 Data Range: 0 to 31 Operational Range: same as data range
 Type: Status
 Supporting information:
 PGN 64947

SPN 3248 (R) Aftertreatment 1 Diesel Particulate Filter Outlet Exhaust Gas Temperature Preliminary FMI

Used to identify the applicable J1939-73 FMI detected in the diesel particulate filter outlet gas temperature sensor by the manufacturer's sensor control software in exhaust bank 1. When there is no failure FMI 31 is sent. In the case of multiple failures the most severe is communicated.

Data Length: 5 bits
Resolution: Binary, 0 offset
Data Range: 0 to 31 Operational Range: same as data range
Type: Status
Supporting information:
PGN 64947

SPN 3249 Aftertreatment 1 Exhaust Gas Temperature 2

The reading from the exhaust gas temperature sensor located midstream of the other two temperature sensors in the aftertreatment system in exhaust bank 1.

Data Length: 2 bytes
Resolution: 0.03125 deg C/bit, -273 deg C offset
Data Range: -273 to 1735 deg C Operational Range: same as data range
Type: Measured
Supporting information:
PGN 64946

SPN 3250 (R) Aftertreatment 1 Diesel Particulate Filter Intermediate Gas Temperature

Temperature of engine combustion byproducts at a mid-point in the diesel particulate filter in exhaust bank 1.

Data Length: 2 bytes
Resolution: 0.03125 deg C/bit, -273 deg C offset
Data Range: -273 to 1735 deg C Operational Range: same as data range
Type: Measured
Supporting information:
PGN 64946

SPN 3251 (R) Aftertreatment 1 Diesel Particulate Filter Differential Pressure

Exhaust differential pressure measured between the intake and exhaust of a diesel particulate filter in exhaust bank 1.

Data Length: 2 bytes
Resolution: 0.1 kPa/bit, 0 offset
Data Range: 0 to 6,425.5 kPa Operational Range: same as data range
Type: Measured
Supporting information:
PGN 64946

SPN 3252 *Aftertreatment 1 Exhaust Gas Temperature 2 Preliminary FMI*

Used to identify the applicable J1939-73 FMI detected in the exhaust gas temperature 2 sensor by the manufacturer's sensor control software in exhaust bank 1. When there is no failure FMI 31 is sent. In the case of multiple failures the most severe is communicated.

Data Length: 5 bits
 Resolution: Binary, 0 offset
 Data Range: 0 to 31 Operational Range: same as data range
 Type: Status
 Supporting information:
 PGN 64946

SPN 3253 (R) *Aftertreatment 1 Diesel Particulate Filter Delta Pressure Preliminary FMI*

Used to identify the applicable J1939-73 FMI detected in the diesel particulate filter differential pressure sensor by the manufacturer's sensor control software in exhaust bank 1. When there is no failure FMI 31 is sent. In the case of multiple failures the most severe is communicated.

Data Length: 5 bits
 Resolution: Binary, 0 offset
 Data Range: 0 to 31 Operational Range: same as data range
 Type: Status
 Supporting information:
 PGN 64946

SPN 3254 (R) *Aftertreatment 1 Diesel Particulate Filter Intermediate Gas Temperature Preliminary FMI*

Used to identify the applicable J1939-73 FMI detected in the diesel particulate filter intermediate gas temperature sensor by the manufacturer's sensor control software in exhaust bank 1. When there is no failure FMI 31 is sent. In the case of multiple failures the most severe is communicated.

Data Length: 5 bits
 Resolution: Binary, 0 offset
 Data Range: 0 to 31 Operational Range: same as data range
 Type: Status
 Supporting information:
 PGN 64946

SPN 3255 *Aftertreatment 2 Intake NOx*

The amount of combined NO and NO₂ in the exhaust entering the aftertreatment system measured by a NO_x sensor at the aftertreatment intake, represented in NO_x molecule parts per million non-NO_x molecules in exhaust bank 2. (For a single exhaust bank system, refer to parameters in PGNs AT11, ATO1, EEC3, AT12, ATO2 and ATM1.)

Data Length: 2 bytes
 Resolution: 0.05 ppm/bit, -200 ppm offset
 Data Range: -200 to 3012.75 ppm Operational Range: same as data range
 Type: Measured
 Supporting information:
 PGN 61456

SPN 3256 (R) Aftertreatment 2 Intake %O2

The actual oxidation factor (%O2) of the gas within the exhaust stream. For positive values, the parameter represents the percent oxygen in excess of the amount required for stoichiometric combustion. For negative values, the parameter is proportional to the amount of oxygen being pumped by the sensor. This value is measured by a sensor at the aftertreatment intake in exhaust bank 2. (For a single exhaust bank system, refer to parameters in PGNs AT11, ATO1, EEC3, AT12, ATO2 and ATM1.)

A value of -12% (0x0000) indicates rich, a value of 21% (0xFAFF) indicates lean. These data points could optionally be used with switching O2 sensors to indicate those states as alternatives to broadcasting the threshold %O2 values. Diagnostic Tools could change display to use the text "Rich" or "Lean" in place of the implied %O2 values which would also be acceptable for display.

Data Length: 2 bytes
 Resolution: 0.000514 %/bit, -12 % offset
 Data Range: -12% to 21% Operational Range: same as data range
 Type: Measured
 Supporting information:
 PGN 61456

SPN 3257 Aftertreatment 2 Intake Gas Sensor Power In Range

Indicates that the power supplied to the aftertreatment intake gas sensor, either NOx or O2, is within the manufacturer's specification in exhaust bank 2. (For a single exhaust bank system, refer to parameters in PGNs AT11, ATO1, EEC3, AT12, ATO2 and ATM1.)

00 - Not in range
 01 - In range
 10 - Error
 11 - Not available

Data Length: 2 bits
 Resolution: 4 states/2 bit, 0 offset
 Data Range: 0 to 3 Operational Range: same as data range
 Type: Status
 Supporting information:
 PGN 61456

SPN 3258 Aftertreatment 2 Intake Gas Sensor at Temperature

Indicates that the heater element of the aftertreatment intake gas sensor, either NOx or O2, is within the manufacturer's specified range for accurate measurements in exhaust bank 2. (For a single exhaust bank system, refer to parameters in PGNs AT11, ATO1, EEC3, AT12, ATO2 and ATM1.)

00 - Not in range
 01 - In range
 10 - Error
 11 - Not available

Data Length: 2 bits
 Resolution: 4 states/2 bit, 0 offset
 Data Range: 0 to 3 Operational Range: same as data range
 Type: Status
 Supporting information:
 PGN 61456

SPN 3259 *Aftertreatment 2 Intake NOx Reading Stable*

Indicates that the NOx reading of the aftertreatment intake NOx sensor is stable as determined by the manufacturer's control software in exhaust bank 2. (For a single exhaust bank system, refer to parameters in PGNs AT11, ATO1, EEC3, AT12, ATO2 and ATM1.)

00 - Not stable
01 - Stable
10 - Error
11 - Not available

Data Length: 2 bits
Resolution: 4 states/2 bit, 0 offset
Data Range: 0 to 3 Operational Range: same as data range
Type: Status
Supporting information:
PGN 61456

SPN 3260 *Aftertreatment 2 Intake Wide-Range % O2 Reading Stable*

Indicates that the %O2 reading of the aftertreatment intake gas sensor, either NOx or O2, is stable as determined by the manufacturer's control software in exhaust bank 2. (For a single exhaust bank system, refer to parameters in PGNs AT11, ATO1, EEC3, AT12, ATO2 and ATM1.)

00 - Not stable
01 - Stable
10 - Error
11 - Not available

Data Length: 2 bits
Resolution: 4 states/2 bit, 0 offset
Data Range: 0 to 3 Operational Range: same as data range
Type: Status
Supporting information:
PGN 61456

SPN 3261 *Aftertreatment 2 Intake Gas Sensor Heater Preliminary FMI*

Used to identify the applicable J1939-73 FMI detected in the heater of the intake exhaust gas sensor, either NOx or O2, by the manufacturer's sensor control software in exhaust bank 2. When there is no failure FMI 31 is sent. In the case of multiple failures the most severe is communicated. (For a single exhaust bank system, refer to parameters in PGNs AT11, ATO1, EEC3, AT12, ATO2 and ATM1.)

Data Length: 5 bits
Resolution: Binary, 0 offset
Data Range: 0 to 31 Operational Range: same as data range
Type: Status
Supporting information:
PGN 61456

SPN 3262 *Aftertreatment 2 Intake Gas Sensor Heater Control*

Indicates the heater status in the warm-up process. Upon receiving a power-up command, the gas sensor ramps up according to a manufacturer defined profile. The Preheat 1, Preheat 2, and Automatic messages are regions within this profile in exhaust bank 2. (For a single exhaust bank system, refer to parameters in PGNs AT11, ATO1, EEC3, AT12, ATO2 and ATM1.)

00 - Automatic
01 - Preheat 2
10 - Preheat 1

Data Length: 2 bits
Resolution: 4 states/2 bit, 0 offset
Data Range: 0 to 3 Operational Range: same as data range
Type: Status
Supporting information:
PGN 61456

SPN 3263 *Aftertreatment 2 Intake NOx Sensor Preliminary FMI*

Used to identify the applicable J1939-73 FMI detected in the aftertreatment intake NOx sensor by the manufacturer's sensor control software in exhaust bank 2. When there is no failure FMI 31 is sent. In the case of multiple failures the most severe is communicated. (For a single exhaust bank system, refer to parameters in PGNs AT11, ATO1, EEC3, AT12, ATO2 and ATM1.)

Data Length: 5 bits
Resolution: Binary, 0 offset
Data Range: 0 to 31 Operational Range: same as data range
Type: Status
Supporting information:
PGN 61456

SPN 3264 *Aftertreatment 2 Intake Oxygen Sensor Preliminary FMI*

Used to identify the applicable J1939-73 FMI detected in the aftertreatment intake oxygen sensor by the manufacturer's sensor control software in exhaust bank 2. When there is no failure FMI 31 is sent. In the case of multiple failures the most severe is communicated. (For a single exhaust bank system, refer to parameters in PGNs AT11, ATO1, EEC3, AT12, ATO2 and ATM1.)

Data Length: 5 bits
Resolution: Binary, 0 offset
Data Range: 0 to 31 Operational Range: same as data range
Type: Status
Supporting information:
PGN 61456

SPN 3265 *Aftertreatment 2 Outlet NOx*

The amount of combined NO and NO2 in the exhaust entering the aftertreatment system measured by a NOx sensor at the aftertreatment outlet, represented in NOx molecule parts per million non-NOx molecules in exhaust bank 2. (For a single exhaust bank system, refer to parameters in PGNs AT11, ATO1, EEC3, AT12, ATO2 and ATM1.)

Data Length: 2 bytes
Resolution: 0.05 ppm/bit, -200 ppm offset
Data Range: -200 to 3012.75 ppm Operational Range: same as data range
Type: Measured
Supporting information:
PGN 61457

SPN 3266 (R) Aftertreatment 2 Outlet %O2

The actual oxidation factor (%O₂) of the gas within the exhaust stream. For positive values, the parameter represents the percent oxygen in excess of the amount required for stoichiometric combustion. For negative values, the parameter is proportional to the amount of oxygen being pumped by the sensor. This value is measured by a sensor at the aftertreatment outlet in exhaust bank 2. (For a single exhaust bank system, refer to parameters in PGNs AT11, ATO1, EEC3, AT12, ATO2 and ATM1.)

A value of -12% (0x0000) indicates rich, a value of 21% (0xFAFF) indicates lean. These data points could optionally be used with switching O₂ sensors to indicate those states as alternatives to broadcasting the threshold %O₂ values. Diagnostic Tools could change display to use the text "Rich" or "Lean" in place of the implied %O₂ values which would also be acceptable for display.

Data Length: 2 bytes
 Resolution: 0.000514 %/bit, -12 % offset
 Data Range: -12% to 21% Operational Range: same as data range
 Type: Measured
 Supporting information:
 PGN 61457

SPN 3267 Aftertreatment 2 Outlet Gas Sensor Power In Range

Indicates that the power supplied to the aftertreatment outlet gas sensor, either NO_x or O₂, is within the manufacturer's specification in exhaust bank 2. (For a single exhaust bank system, refer to parameters in PGNs AT11, ATO1, EEC3, AT12, ATO2 and ATM1.)

00 - Not in range
 01 - In range
 10 - Error
 11 - Not available

Data Length: 2 bits
 Resolution: 4 states/2 bit, 0 offset
 Data Range: 0 to 3 Operational Range: same as data range
 Type: Status
 Supporting information:
 PGN 61457

SPN 3268 Aftertreatment 2 Outlet Gas Sensor at Temperature

Indicates that the heater element of the aftertreatment outlet gas sensor, either NO_x or O₂, is within the manufacturer's specified range for accurate measurements in exhaust bank 2. (For a single exhaust bank system, refer to parameters in PGNs AT11, ATO1, EEC3, AT12, ATO2 and ATM1.)

00 - Not in range
 01 - In range
 10 - Error
 11 - Not available

Data Length: 2 bits
 Resolution: 4 states/2 bit, 0 offset
 Data Range: 0 to 3 Operational Range: same as data range
 Type: Status
 Supporting information:
 PGN 61457

SPN 3269 *Aftertreatment 2 Outlet NOx Reading Stable*

Indicates that the NOx reading of the aftertreatment outlet NOx sensor is stable as determined by the manufacturer's control software in exhaust bank 2. (For a single exhaust bank system, refer to parameters in PGNs AT11, ATO1, EEC3, AT12, ATO2 and ATM1.)

00 - Not stable
01 - Stable
10 - Error
11 - Not available

Data Length: 2 bits
Resolution: 4 states/2 bit, 0 offset
Data Range: 0 to 3 Operational Range: same as data range
Type: Status
Supporting information:
PGN 61457

SPN 3270 *Aftertreatment 2 Outlet Wide-Range % O2 Reading Stable*

Indicates that the %O2 reading of the aftertreatment outlet gas sensor, either NOx or O2, is stable as determined by the manufacturer's control software in exhaust bank 2. (For a single exhaust bank system, refer to parameters in PGNs AT11, ATO1, EEC3, AT12, ATO2 and ATM1.)

00 - Not stable
01 - Stable
10 - Error
11 - Not available

Data Length: 2 bits
Resolution: 4 states/2 bit, 0 offset
Data Range: 0 to 3 Operational Range: same as data range
Type: Status
Supporting information:
PGN 61457

SPN 3271 *Aftertreatment 2 Outlet Gas Sensor Heater Preliminary FMI*

Used to identify the applicable J1939-73 FMI detected in the heater of the outlet exhaust gas sensor, either NOx or O2, by the manufacturer's sensor control software in exhaust bank 2. When there is no failure FMI 31 is sent. In the case of multiple failures the most severe is communicated. (For a single exhaust bank system, refer to parameters in PGNs AT11, ATO1, EEC3, AT12, ATO2 and ATM1.)

Data Length: 5 bits
Resolution: Binary, 0 offset
Data Range: 0 to 31 Operational Range: same as data range
Type: Status
Supporting information:
PGN 61457

SPN 3272 *Aftertreatment 2 Outlet Gas Sensor Heater Control*

Indicates the heater status in the warm-up process. Upon receiving a power-up command, the gas sensor ramps up according to a manufacturer defined profile. The Preheat 1, Preheat 2, and Automatic messages are regions within this profile in exhaust bank 2. (For a single exhaust bank system, refer to parameters in PGNs AT11, ATO1, EEC3, AT12, ATO2 and ATM1.)

00 - Automatic
01 - Preheat 2
10 - Preheat 1
11 - Heater off

Data Length: 2 bits
Resolution: 4 states/2 bit, 0 offset
Data Range: 0 to 3 Operational Range: same as data range
Type: Status
Supporting information:
PGN 61457

SPN 3273 *Aftertreatment 2 Outlet NOx Sensor Preliminary FMI*

Used to identify the applicable J1939-73 FMI detected in the aftertreatment outlet NOx sensor by the manufacturer's sensor control software in exhaust bank 2. When there is no failure FMI 31 is sent. In the case of multiple failures the most severe is communicated. (For a single exhaust bank system, refer to parameters in PGNs AT11, ATO1, EEC3,

Data Length: 5 bits
Resolution: Binary, 0 offset
Data Range: 0 to 31 Operational Range: same as data range
Type: Status
Supporting information:
PGN 61457

SPN 3274 *Aftertreatment 2 Outlet Oxygen Sensor Preliminary FMI*

Used to identify the applicable J1939-73 FMI detected in the aftertreatment outlet oxygen sensor by the manufacturer's sensor control software in exhaust bank 2. When there is no failure FMI 31 is sent. In the case of multiple failures the most severe is communicated. (For a single exhaust bank system, refer to parameters in PGNs AT11, ATO1, EEC3, AT12,

Data Length: 5 bits
Resolution: Binary, 0 offset
Data Range: 0 to 31 Operational Range: same as data range
Type: Status
Supporting information:
PGN 61457

SPN 3275 *Aftertreatment 2 Exhaust Gas Temperature 1*

The reading from the exhaust gas temperature sensor located farthest upstream in the aftertreatment system in exhaust bank 2. (For a single exhaust bank system, refer to parameters in PGNs AT11, ATO1, EEC3, AT12, ATO2 and ATM1.)

Data Length: 2 bytes
Resolution: 0.03125 deg C/bit, -273 deg C offset
Data Range: -273 to 1735 deg C Operational Range: same as data range
Type: Measured
Supporting information:
PGN 64945

SPN 3276 (R) Aftertreatment 2 Diesel Particulate Filter Intake Gas Temperature

Temperature of engine combustion byproducts entering the diesel particulate filter in exhaust bank 2. (For a single exhaust bank system, refer to parameters in PGNs AT11, ATO1, EEC3, AT12, ATO2 and ATM1.)

Data Length: 2 bytes
Resolution: 0.03125 deg C/bit, -273 deg C offset
Data Range: -273 to 1735 deg C Operational Range: same as data range
Type: Measured
Supporting information:
PGN 64945

SPN 3277 Aftertreatment 2 Exhaust Gas Temperature 1 Preliminary FMI

Used to identify the applicable J1939-73 FMI detected in the exhaust gas temperature 1 sensor by the manufacturer's sensor control software in exhaust bank 2. When there is no failure FMI 31 is sent. In the case of multiple failures the most severe is communicated. (For a single exhaust bank system, refer to parameters in PGNs AT11, ATO1, EEC3, AT12, ATO2 and ATM1.)

Data Length: 5 bits
Resolution: Binary, 0 offset
Data Range: 0 to 31 Operational Range: same as data range
Type: Status
Supporting information:
PGN 64945

SPN 3278 (R) Aftertreatment 2 Diesel Particulate Filter Intake Gas Temperature Preliminary FMI

Used to identify the applicable J1939-73 FMI detected in the diesel particulate filter intake gas temperature sensor by the manufacturer's sensor control software in exhaust bank 2. When there is no failure FMI 31 is sent. In the case of multiple failures the most severe is communicated. (For a single exhaust bank system, refer to parameters in PGNs AT11, ATO1, EEC3, AT12, ATO2 and ATM1.)

Data Length: 5 bits
Resolution: Binary, 0 offset
Data Range: 0 to 31 Operational Range: same as data range
Type: Status
Supporting information:
PGN 64945

SPN 3279 Aftertreatment 2 Exhaust Gas Temperature 3

The reading from the exhaust gas temperature sensor located farthest downstream in the aftertreatment system in exhaust bank 2. (For a single exhaust bank system, refer to parameters in PGNs AT11, ATO1, EEC3, AT12, ATO2 and ATM1.)

Data Length: 2 bytes
Resolution: 0.03125 deg C/bit, -273 deg C offset
Data Range: -273 to 1735 deg C Operational Range: same as data range
Type: Measured
Supporting information:
PGN 64944

SPN 3280 (R) Aftertreatment 2 Diesel Particulate Filter Outlet Gas Temperature

Temperature of engine combustion byproducts leaving the diesel particulate filter exhaust in exhaust bank 2. (For a single exhaust bank system, refer to parameters in PGNs AT11, ATO1, EEC3, AT12, ATO2 and ATM1.)

Data Length: 2 bytes
 Resolution: 0.03125 deg C/bit, -273 deg C offset
 Data Range: -273 to 1735 deg C Operational Range: same as data range
 Type: Measured
 Supporting information:
 PGN 64944

SPN 3281 Aftertreatment 2 Exhaust Gas Temperature 3 Preliminary FMI

Used to identify the applicable J1939-73 FMI detected in the exhaust gas temperature 3 sensor by the manufacturer's sensor control software in exhaust bank 2. When there is no failure FMI 31 is sent. In the case of multiple failures the most severe is communicated. (For a single exhaust bank system, refer to parameters in PGNs AT11, ATO1, EEC3, AT12, ATO2 and ATM1.)

Data Length: 5 bits
 Resolution: Binary, 0 offset
 Data Range: 0 to 31 Operational Range: same as data range
 Type: Status
 Supporting information:
 PGN 64944

SPN 3282 (R) Aftertreatment 2 Diesel Particulate Filter Exhaust Gas Temperature Preliminary FMI

Used to identify the applicable J1939-73 FMI detected in the diesel particulate filter outlet gas temperature sensor by the manufacturer's sensor control software in exhaust bank 2. When there is no failure FMI 31 is sent. In the case of multiple failures the most severe is communicated. (For a single exhaust bank system, refer to parameters in PGNs AT11, ATO1, EEC3, AT12, ATO2 and ATM1.)

Data Length: 5 bits
 Resolution: Binary, 0 offset
 Data Range: 0 to 31 Operational Range: same as data range
 Type: Status
 Supporting information:
 PGN 64944

SPN 3283 Aftertreatment 2 Exhaust Gas Temperature 2

The reading from the exhaust gas temperature sensor located midstream of the other two temperature sensors in the aftertreatment system in exhaust bank 2. (For a single exhaust bank system, refer to parameters in PGNs AT11, ATO1, EEC3, AT12, ATO2 and ATM1.)

Data Length: 2 bytes
 Resolution: 0.03125 deg C/bit, -273 deg C offset
 Data Range: -273 to 1735 deg C Operational Range: same as data range
 Type: Measured
 Supporting information:
 PGN 64943

SPN 3284 (R) Aftertreatment 2 Diesel Particulate Filter Intermediate Gas Temperature

Temperature of engine combustion byproducts at a mid-point in the diesel particulate filter in exhaust bank 2. (For a single exhaust bank system, refer to parameters in PGNs ATI1, ATO1, EEC3, ATI2, ATO2 and ATM1.)

Data Length: 2 bytes
 Resolution: 0.03125 deg C/bit, -273 deg C offset
 Data Range: -273 to 1735 deg C Operational Range: same as data range
 Type: Measured
 Supporting information:
 PGN 64943

SPN 3285 (R) Aftertreatment 2 Diesel Particulate Filter Differential Pressure

Exhaust differential pressure measured between the intake and exhaust of a diesel particulate filter in exhaust bank 2. (For a single exhaust bank system, refer to parameters in PGNs ATI1, ATO1, EEC3, ATI2, ATO2 and ATM1.)

Data Length: 2 bytes
 Resolution: 0.1 kPa/bit, 0 offset
 Data Range: 0 to 6,425.5 kPa Operational Range: same as data range
 Type: Measured
 Supporting information:
 PGN 64943

SPN 3286 Aftertreatment 2 Exhaust Gas Temperature 2 Preliminary FMI

Used to identify the applicable J1939-73 FMI detected in the exhaust gas temperature 2 sensor by the manufacturer's sensor control software in exhaust bank 2. When there is no failure FMI 31 is sent. In the case of multiple failures the most severe is communicated. (For a single exhaust bank system, refer to parameters in PGNs ATI1, ATO1, EEC3, ATI2, and ATM1.)

Data Length: 5 bits
 Resolution: Binary, 0 offset
 Data Range: 0 to 31 Operational Range: same as data range
 Type: Status
 Supporting information:
 PGN 64943

SPN 3287 (R) Aftertreatment 2 Diesel Particulate Filter Delta Pressure Preliminary FMI

Used to identify the applicable J1939-73 FMI detected in the diesel particulate filter differential pressure sensor by the manufacturer's sensor control software in exhaust bank 2. When there is no failure FMI 31 is sent. In the case of multiple failures the most severe is communicated. (For a single exhaust bank system, refer to parameters in PGNs ATI1, ATO1, EEC3, ATI2, ATO2 and ATM1.)

Data Length: 5 bits
 Resolution: Binary, 0 offset
 Data Range: 0 to 31 Operational Range: same as data range
 Type: Status
 Supporting information:
 PGN 64943

SPN 3288 (R) Aftertreatment 2 Diesel Particulate Filter Intermediate Gas Temperature Preliminary FMI

Used to identify the applicable J1939-73 FMI detected in the diesel particulate filter intermediate gas temperature sensor by the manufacturer's sensor control software in exhaust bank 2. When there is no failure FMI 31 is sent. In the case of multiple failures the most severe is communicated. (For a single exhaust bank system, refer to parameters in PGNs AT11, ATO1, EEC3, AT12, ATO2 and ATM1.)

Data Length: 5 bits
 Resolution: Binary, 0 offset
 Data Range: 0 to 31 Operational Range: same as data range
 Type: Status
 Supporting information:
 PGN 64943

SPN 3289 (R) Transmission Requested Gear Feedback

Feedback of the SPN 525 Transmission Requested Gear input as received from the shift selector, ABS or engine via PGN 256, Transmission Control 1 (TC1) or other transmission selector input. Scaling, values and parameter specific indicators are identical to those listed for SPN 525 Requested Gear.

This feedback from the transmission allows shift selectors and other TC1 input devices to verify that their Transmission Requested Gear command has been properly received by the transmission. (This parameter is not intended for driver display purposes).

In systems with mechanical or electrical shift selectors which do not support J1939 communication, this parameter allows the transmission ECU to convey the requested gear as interpreted by the transmission from its mechanical or electrical shift selector.

Data Length: 1 byte
 Resolution: 1 gear value/bit, -125 offset
 Data Range: -125 to 125 Operational Range: same as data range
 Type: Status
 Supporting information:
 PGN 65098

SPN 3307 **Fifth Wheel Error Status**

Fifth wheel error state which conveys information when coupling status is incomplete or bad.

0000 0 - Improper Couple
0001 1 - Locks Closed / No Kingpin at Startup
0010 2 - Kingpin / Locks Open at Startup
0011 3 - Not Used
0100 4 - Not Used
0101 5 - Coupling Sequence Error
0110 6 - Coupling Sequence Error / Kingpin
0111 7 - Coupling Timing Error
1000 8 - Kingpin Missing More Than 5 Seconds
1001 9 - Kingpin / Lock Open (Handle Pulled)
1010 10 - Not Used
1011 11 - Not Used
1100 12 - Not Used
1101 13 - Not Used
1110 14 - Not Used
1111 15 - Not available

Data Length: 4 bits
Resolution: 16 states/4 bit, 0 offset
Data Range: 0 to 15 Operational Range: same as data range
Type: Status
Supporting information:
PGN 64942

SPN 3308 **Fifth Wheel Vertical Force**

The amount of load being applied to the fifth wheel by the trailer. Zero load is indicated without a trailer.

Data Length: 2 bytes
Resolution: 5 N/bit, 0 offset
Data Range: 0 to 321,275 N Operational Range: same as data range
Type: Measured
Supporting information:
PGN 61458

SPN 3309 **Fifth Wheel Drawbar Force**

Fifth wheel drawbar force, with the trailer held stationary a positive force is generated by the vehicle pulling forward.

Data Length: 2 bytes
Resolution: 10 N/bit, -320,000 N offset
Data Range: -320,000 to 322,550 N Operational Range: same as data range
Type: Measured
Supporting information:
PGN 61458

SPN 3310 Fifth Wheel Roll Moment

Fifth wheel roll moment force - If the moment is positive, the trailer is rolling clockwise relative to the normal vehicle forward motion.

Data Length: 2 bytes
 Resolution: 10 N/bit, -320,000 N offset
 Data Range: -320,000 to 322,550 N Operational Range: same as data range
 Type: Measured
 Supporting information:
 PGN 61458

SPN 3311 Fifth Wheel Slider Position

Slider position measurement. Zero equals fully back position, that is, the farthest to the rear of the vehicle.

Data Length: 1 byte
 Resolution: 10 mm/bit, 0 offset
 Data Range: 0 to 2500 mm (0 to 2.500 Operational Range: same as data range
 Type: Measured
 Supporting information:
 PGN 64942

SPN 3312 Fifth Wheel Lock Ready to Couple Indicator

Indicates to the vehicle operator that the fifth wheel lock is open and ready to couple.

00 Lock not open, not ready to couple
 01 Lock open, ready to couple
 10 Error
 11 Not Available

Data Length: 2 bits
 Resolution: 4 states/2 bit, 0 offset
 Data Range: 0 to 3 Operational Range: same as data range
 Type: Status
 Supporting information:
 PGN 64942

SPN 3313 Fifth Wheel Lock Couple Status Indicator

Indicates results of coupling operation to the vehicle operator. For incomplete couples further information can be obtained from the fifth wheel error status SPN.

00 Incomplete or bad couple, truck should not be moved
 01 Successful couple detected
 10 Error
 11 Not Available

Data Length: 2 bits
 Resolution: 4 states/2 bit, 0 offset
 Data Range: 0 to 3 Operational Range: same as data range
 Type: Status
 Supporting information:
 PGN 64942

SPN 3314 Fifth Wheel Release Control

Operator input used to release the fifth wheel. Fifth Wheel Release Control Security Lockout and other conditions must be properly enabled before this will function.

00 Coupler Locked
01 Coupler Unlocked, trailer can be unhitched or hitched
10 Error
11 Not Available

Data Length: 2 bits
Resolution: 4 states/2 bit, 0 offset
Data Range: 0 to 3 Operational Range: same as data range
Type: Measured
Supporting information:
PGN 64980

SPN 3315 Fifth Wheel Release Control Security Lockout

Operator's fifth wheel release control interlock. This operator input must be enabled prior to activating the fifth wheel release control (SPN 3314).

00 Fifth wheel release Disabled
01 Fifth wheel release Enabled
10 Error
11 Not Available

Data Length: 2 bits
Resolution: 4 states/2 bit, 0 offset
Data Range: 0 to 3 Operational Range: same as data range
Type: Measured
Supporting information:
PGN 64980

SPN 3316 Fifth Wheel Slider Lock Indicator

Indicates to vehicle operator that the fifth wheel slider is in position and locked.

00 Not Locked
01 Locked
10 Error
11 Not Available

Data Length: 2 bits
Resolution: 4 states/2 bit, 0 offset
Data Range: 0 to 3 Operational Range: same as data range
Type: Measured
Supporting information:
PGN 64942

SPN 3317 **Fifth Wheel Roll Warning Indicator**

Indicates to the vehicle operator that the roll moment has exceeded a preset limit.

00 Limit not exceeded

01 Limit exceeded

10 error

11 Not Available

Data Length: 2 bits

Resolution: 4 states/2 bit, 0 offset

Data Range: 0 to 3 Operational Range: same as data range

Type: Status

Supporting information:

PGN 61458

SPN 3318 **Pitch Angle**

The angle between the vehicle x-axis and the ground plane.

Data Length: 2 bytes

Resolution: 0.002 deg/bit, -64 offset

Data Range: -64 to 64.51 deg Operational Range: same as data range

Type: Measured

Supporting information:

PGN 61459

SPN 3319 **Roll Angle**

The angle between the vehicle y-axis and the ground plane.

Data Length: 2 bytes

Resolution: 0.002 deg/bit, -64 offset

Data Range: -64 to 64.51 deg Operational Range: same as data range

Type: Measured

Supporting information:

PGN 61459

SPN 3322 **Pitch Rate**

Pitch rate is the rate-of-change of the pitch angle over time, where the pitch angle vector is in the direction of travel of the vehicle.

Data Length: 2 bytes

Resolution: 0.002 deg/sec per bit, -64 deg/sec offset

Data Range: -64 to 64.51 deg/sec Operational Range: same as data range

Type: Measured

Supporting information:

PGN 61459

SPN 3323 **Pitch Angle Figure of Merit**

Figure of merit for pitch angle measurement.

Bit 2 Bit 1

0 0 Pitch angle fully functional. Data is within sensor specification.
 0 1 Pitch angle degraded. Data is suspect due to environmental conditions.
 1 0 Error
 1 1 Not available

Data Length: 2 bits
 Resolution: 4 states/2 bit, 0 offset
 Data Range: 0 to 3 Operational Range: same as data range
 Type: Status
 Supporting information:
 PGN 61459

SPN 3324 **Roll Angle Figure of Merit**

Figure of merit for roll angle measurement.

Bit 4 Bit 3

0 0 Roll angle fully functional. Data is within sensor specification.
 0 1 Roll angle degraded. Data is suspect due to environmental conditions.
 1 0 Error
 1 1 Not available

Data Length: 2 bits
 Resolution: 4 states/2 bit, 0 offset
 Data Range: 0 to 3 Operational Range: same as data range
 Type: Status
 Supporting information:
 PGN 61459

SPN 3325 **Pitch Rate Figure of Merit**

Figure of merit for the pitch rate measurement.

Bit 6 Bit 5

0 0 Pitch rate fully functional. Data is within sensor specification.
 0 1 Pitch rate degraded. Data is suspect due to environmental conditions.
 1 0 Error
 1 1 Not available

Data Length: 2 bits
 Resolution: 4 states/2 bit, 0 offset
 Data Range: 0 to 3 Operational Range: same as data range
 Type: Status
 Supporting information:
 PGN 61459

SPN 3326 Pitch and Roll Compensated

Compensated mode for the pitch and roll measurements. Compensation is the use of multiple sensors together to enhance the output of pitch and roll measurements.

Bit 8 Bit 7

0 0 Compensation Off
 0 1 Compensation On
 1 0 Error
 1 1 Not Available

Data Length: 2 bits

Resolution: 4 states/2 bit, 0 offset

Data Range: 0 to 3 Operational Range: same as data range

Type: Status

Supporting information:

PGN 61459

SPN 3327 Roll and Pitch Measurement Latency

The estimated measurement latency of the measurement. NOTE: This is only the sensor latency and does not include any additional latencies that might exist because of the CAN Bus or overall system implementation. Latency is the time from sensor readings to the queuing of the message data for CAN transmission.

Data Length: 1 byte

Resolution: 0.5 ms/bit, 0 offset

Data Range: 0 to 125 ms Operational Range: same as data range

Type: Measured

Supporting information:

PGN 61459

SPN 3331 Blade Rotation Angle

The blade rotation angle measurement around the yaw (z-axis).

Data Length: 2 bytes

Resolution: 1/128 deg/bit, -200 deg offset

Data Range: -200 to 301.99 deg Operational Range: same as data range

Type: Measured

Supporting information:

PGN 61460

SPN 3332 *Blade Rotation Angle Figure of Merit*

Figure of merit for blade rotation measurement.

Bits

00 Blade Rotation Angle fully functional. Data is within sensor specification.

01 Blade Rotation Angle degraded. Data is suspect due to environmental conditions.

10 Blade Rotation Angle failed. Roll sensor failed to operate correctly.

11 Blade Rotation Angle not available

Data Length: 2 bits

Resolution: 4 states/2 bit, 0 offset

Data Range: 0 to 3

Operational Range: same as data range

Type: Status

Supporting information:

PGN 61460

SPN 3334 Left Blade Control Mode Operator Control

This parameter indicates the left blade control mode operator control state the user has set for the land leveling system. The operator control value directly relates to the current operator control state correlating to the left edge of the blade. The purpose of this parameter is to set the control mode (auto/manual) for the left side of the blade. For this system, the left and right side of the blade can be adjusted independently of each other to either change the elevation from a given reference point or the blade angle (also known as blade tilt)/cross slope depending on the function requested by the operator.

This parameter is intended for use in systems using two parameters (right/left) to control the blade as described above. Systems using only one parameter to control blade position, i.e. elevation, should use the Blade Control Mode Switch parameter. Only one of the following states will be active at a time. In the example below, data values are defined for each switch type that may be used in an application. The purpose of the following switch information is to define what data should be reported based on what type of switch is used.

1. A toggle button with two states can be used, in which the button is either in the manual or the auto position at all times.

Toggle button usage is as follows:

Manual Button Pressed = 0010 Manual Operator Control Request
 Automatic Button Pressed = 0011 Automatic Operator Control Request
 Invalid Switch Input(ex. auto and manual read/pressed simultaneously) = 1110 Error Indicator

2. The momentary rocker switch may be used, where the default is the no button pressed position. The user can press the rocker into the manual position, and when pressure is released, it will return to the no button pressed position. The user may also press the rocker into the auto position, and when pressure is released, it will return to the no button pressed position.

Momentary rocker button usage is as follows:

No button pressed = 0000 No change
 Manual Button Pressed = 0010 Manual Operator Control Request
 Automatic Button Pressed = 0011 Automatic Operator Control Request
 Invalid Switch Input(ex. auto and manual read/pressed simultaneously) = 1110 Error Indicator

3. The momentary contact button pair may be used, where the default is no buttons being pressed. The user can press the manual button, and when pressure is released, it will return to the no button pressed position. The user may press the auto button, and when pressure is released, it will return to the no button pressed position.

Momentary contact buttons (button pair) usage is as follows:

No button pressed = 0000 No change
 Manual Button Pressed = 0010 Manual Operator Control Request
 Automatic Button Pressed = 0011 Automatic Operator Control Request
 Invalid Switch Input(ex. auto and manual read/pressed simultaneously) = 1110 Error Indicator

4. The momentary contact single button may be used, where the default is no button being pressed. The user can press the button, which is the button pressed position, and when pressure is released, it will return to the no button pressed position. The controller receiving this command will keep track of what mode the blade is in, auto or manual. If the blade is in manual mode to begin with, one press of the button will change to mode to auto. If the button is pressed again, the blade will be put into manual mode.

Momentary contact button (single button) usage is as follows:

No button pressed = 0000 No change
 Mode Button Pressed = 0001 Momentary Operator Control Request

Data Values and Descriptions:

0000 No Change
 0001 Momentary Operator Control Request
 0010 Manual Operator Control Request
 0011 Automatic Operator Control Request
 1100 - 1101 Reserved
 1110 Error Indicator
 1111 Not Installed

Notes:

1. The operator control state can be read in two ways. One method uses the direct operator control input to determine the operator control state, while the second method relies on a secondary control to read the operator control input, then relay

the information on the data link. The parameter is designed to provide the actual operator control state to other controls that need the information.

2. Other systems with automated blade controls should be able to use this parameter, since it is an actual operator control value.

Data Length: 4 bits

Resolution: 16 states/4 bit, 0 offset

Data Range: 0 to 15

Operational Range: same as data range

Type: Measured

Supporting information:

PGN 61453

SPN 3335 Right Blade Control Mode Operator Control

This parameter indicates the right blade control mode operator control state the user has set for the land leveling system. The operator control value directly relates to the current operator control state correlating to the left edge of the blade. The purpose of this parameter is to set the control mode (auto/manual) for the left side of the blade. For this system, the left and right side of the blade can be adjusted independently of each other to either change the elevation from a given reference point or the blade angle (also known as blade tilt)/cross slope depending on the function requested by the operator.

This parameter is intended for use in systems using two parameters(right/left) to control the blade as described above. Systems using only one parameter to control blade position, i.e. elevation, should use the Blade Control Mode Switch parameter. Only one of the following states will be active at a time. In the example below, data values are defined for each switch type that may be used in an application. The purpose of the following switch information is to define what data should be reported based on what type of switch is used.

1. A toggle button with two states can be used, in which the button is either in the manual or the auto position at all times.

Toggle button usage is as follows:

Manual Button Pressed = 0010 Manual Operator Control Request
Automatic Button Pressed = 0011 Automatic Operator Control Request
Invalid Switch Input(ex. auto and manual read/pressed simultaneously) = 1110 Error Indicator

2. The momentary rocker switch may be used, where the default is the no button pressed position. The user can press the rocker into the manual position, and when pressure is released, it will return to the no button pressed position. The user may also press the rocker into the auto position, and when pressure is released, it will return to the no button pressed position.

Momentary rocker button usage is as follows:

No button pressed = 0000 No change
Manual Button Pressed = 0010 Manual Operator Control Request
Automatic Button Pressed = 0011 Automatic Operator Control Request
Invalid Switch Input(ex. auto and manual read/pressed simultaneously) = 1110 Error Indicator

3. The momentary contact button pair may be used, where the default is no buttons being pressed. The user can press the manual button, and when pressure is released, it will return to the no button pressed position. The user may press the auto button, and when pressure is released, it will return to the no button pressed position.

Momentary contact buttons (button pair) usage is as follows:

No button pressed = 0000 No change
Manual Button Pressed = 0010 Manual Operator Control Request
Automatic Button Pressed = 0011 Automatic Operator Control Request
Invalid Switch Input(ex. auto and manual read/pressed simultaneously) = 1110 Error Indicator

4. The momentary contact single button may be used, where the default is no button being pressed. The user can press the button, which is the button pressed position, and when pressure is released, it will return to the no button pressed position. The controller receiving this command will keep track of what mode the blade is in, auto or manual. If the blade is in manual mode to begin with, one press of the button will change to mode to auto. If the button is pressed again, the blade will be put into manual mode.

Momentary contact button (single button) usage is as follows:

No button pressed = 0000 No change
Mode Button Pressed = 0001 Momentary Operator Control Request

Data Values and Descriptions:

0000 No Change
0001 Momentary Operator Control Request
0010 Manual Operator Control Request
0011 Automatic Operator Control Request
1110 Error Indicator
1111 Not Installed

Data Length: 4 bits

Resolution: 16 states/4 bit, 0 offset

Data Range: 0 to 15 Operational Range: same as data range

Type: Measured

Supporting information:

PGN 61453

SPN 3336 Left Desired Blade Offset Operator Control

This parameter indicates the left blade offset operator control state the user has set for the land leveling system. The left desired blade offset value is the offset measured from a given reference point to the bottom left edge of the blade. This parameter will only be used when the control mode for land leveling system has been set to auto. The purpose of this parameter is to adjust the elevation from a given reference point or the blade angle(also known as blade tilt)/cross slope depending on the function being requested by the operator for the left side of the blade.

This parameter is intended for use in systems using two parameters(left/right) to control the blade as described above. Systems using only one parameter to control blade position, i.e. elevation, should use the Desired Blade Offset Switch parameter. Only one of the following states will be active at a time.

In the example below, data values are defined for each switch type that may be used in an application. The purpose of the following switch information is to define what data should be reported based on what type of switch is used.

1. The momentary rocker switch may be used, where the default is the neutral position with no buttons pressed. The user can press the rocker into the increment button pressed position, and when pressure is released, it will return to the neutral position. The user may also press the rocker into the decrement button pressed position, and when pressure is released, it will return to the neutral position. Momentary rocker button usage is as follows:

Neutral position = 0000 No Operator Control Request
 Increment Button Pressed = 0001 Increment Operator Control Request
 Decrement Button Pressed = 0010 Decrement Operator Control Request
 Invalid Switch Input(ex. inc./dec. values read simultaneously) = 1110 Error Indicator

2. The momentary contact button pair may be used, where the default is the neutral position with no buttons pressed. The user can press the increment button, and when pressure is released, it will return to the neutral position. The user may press the decrement button, and when pressure is released, it will return to the neutral position. Momentary contact button (button pair) usage is as follows:

No Button Pressed = 0000 No Operator Control Request
 Increment Button Pressed = 0001 Increment Operator Control Request
 Decrement Button Pressed = 0010 Decrement Operator Control Request
 Invalid Switch Input(ex. inc./dec. values read simultaneously) = 1110 Error Indicator

Data Values and Descriptions:

0000 No Operator Control Request
 0001 Increment Operator Control Request
 0010 Decrement Operator Control Request
 0011 - 1101 Reserved
 1110 Error Indicator
 1111 Not installed

Notes:

1. The operator control state can be read in two ways. One method uses the direct operator control input to determine the operator control state, while the second method relies on a secondary control to read the operator control input, then relay the information on the data link. The parameter is designed to provide the actual operator control state to other controls that need the information.
2. Other systems with automated blade controls should be able to use this parameter, since it is an actual operator control value.

Data Length: 4 bits
 Resolution: 16 states/4 bit, 0 offset
 Data Range: 0 to 15 Operational Range: same as data range
 Type: Measured
 Supporting information:
 PGN 61453

SPN 3337 Right Desired Blade Offset Operator Control

This parameter indicates the right blade offset operator control state the user has set for the land leveling system. The right desired blade offset value is the offset measured from a given reference point to the bottom right edge of the blade. This parameter will only be used when the control mode for land leveling system has been set to auto. The purpose of this parameter is to adjust the elevation from a given reference point or the blade angle(also known as blade tilt)/cross slope depending on the function being requested by the operator for the left side of the blade.

This parameter is intended for use in systems using two parameters(left/right) to control the blade as described above. Systems using only one parameter to control blade position, i.e. elevation, should use the Desired Blade Offset Switch parameter. Only one of the following states will be active at a time.

In the example below, data values are defined for each switch type that may be used in an application. The purpose of the following switch information is to define what data should be reported based on what type of switch is used.

1. The momentary rocker switch may be used, where the default is the neutral position with no buttons pressed. The user can press the rocker into the increment button pressed position, and when pressure is released, it will return to the neutral position. The user may also press the rocker into the decrement button pressed position, and when pressure is released, it will return to the neutral position. Momentary rocker button usage is as follows:

Neutral position = 0000 No Operator Control Request
 Increment Button Pressed = 0001 Increment Operator Control Request
 Decrement Button Pressed = 0010 Decrement Operator Control Request
 Invalid Switch Input(ex. inc./dec. values read simultaneously) = 1110 Error Indicator

2. The momentary contact button pair may be used, where the default is the neutral position with no buttons pressed. The user can press the increment button, and when pressure is released, it will return to the neutral position. The user may press the decrement button, and when pressure is released, it will return to the neutral position. Momentary contact button (button pair) usage is as follows:

No Button Pressed = 0000 No Operator Control Request
 Increment Button Pressed = 0001 Increment Operator Control Request
 Decrement Button Pressed = 0010 Decrement Operator Control Request
 Invalid Switch Input(ex. inc./dec. values read simultaneously) = 1110 Error Indicator

Data Values and Descriptions:

0000 No Operator Control Request
 0001 Increment Operator Control Request
 0010 Decrement Operator Control Request
 0011 - 1101 Reserved
 1110 Error Indicator
 1111 Not installed

Notes:

1. The operator control state can be read in two ways. One method uses the direct operator control input to determine the operator control state, while the second method relies on a secondary control to read the operator control input, then relay the information on the data link. The parameter is designed to provide the actual operator control state to other controls that need the information.
2. Other systems with automated blade controls should be able to use this parameter, since it is an actual operator control value.

Data Length: 4 bits
 Resolution: 16 states/4 bit, 0 offset
 Data Range: 0 to 15 Operational Range: same as data range
 Type: Measured
 Supporting information:
 PGN 61453

SPN 3338 Side-shift Blade Control Mode Operator Control

This parameter indicates the side-shift offset operator control state the user has set for the land leveling system. When an implement moves in a side-shift direction, it moves from side to side, usually along its longitudinal axis. The desired side-shift offset value is the offset measured from a given vertical reference point to the center of the blade.

Only one of the following states will be active at a time. In the example below, the data values are defined for each switch type that may be used in an application. The purpose of the following switch information is to define what data should be reported based on what type of switch is used.

1. The momentary rocker switch may be used, where the default is the neutral position with no buttons pressed. The user can press the rocker into the increment button pressed position, and when pressure is released, it will return to the neutral position. The user may also press the rocker into the decrement button pressed position, and when pressure is released, it will return to the neutral position. Momentary rocker button usage is as follows:

- Neutral position = 0000 No Operator Control Request
- Increment Button Pressed = 0001 Increment Operator Control Request
- Decrement Button Pressed = 0010 Decrement Operator Control Request

2. The momentary contact button pair may be used, where the default is the neutral position with no buttons pressed. The user can press the increment button, and when pressure is released, it will return to the neutral position. The user may press the decrement button, and when pressure is released, it will return to the neutral position. Momentary contact button (button pair) usage is as follows:

- No Button Pressed = 0000 No Operator Control Request
- Increment Button Pressed = 0001 Increment Operator Control Request
- Decrement Button Pressed = 0010 Decrement Operator Control Request

Data Values and Descriptions:

0000 No Operator Control Request
 0001 Increment Operator Control Request
 0010 Decrement Operator Control Request
 0011-1101 Reserved
 1110 Error Indicator
 1111 Not installed

Data Length:	4 bits	
Resolution:	16 states/4 bit, 0 offset	
Data Range:	0 to 15	Operational Range: same as data range
Type:	Measured	
Supporting information:		
PGN	61453	

SPN 3339 Side-shift Desired Blade Offset Operator Control

This parameter indicates the side-shift blade control mode operator control state the user has set for the land leveling system. When an implement moves in a side-shift direction, it moves from side to side, usually along its longitudinal axis.

The operator control value directly correlates to the current operator control state. Only one of the following states will be active at a time. In the example below, the data values are defined for each switch type that may be used in an application. The purpose of the following switch information is to define what data should be reported based on what type of switch is used.

1. A toggle button with two states can be used, in which the button is either in the manual or the auto position at all times.

Toggle button usage is as follows:

Manual Position = 0010 Manual Operator Control Request
Auto Position = 0011 Automatic Operator Control Request

2. The momentary rocker switch may be used, where the default is the no button pressed position. The user can press the rocker into the manual position, and when pressure is released, it will return to the no button pressed position. The user may also press the rocker into the auto position, and when pressure is released, it will return to the no button pressed position. Momentary rocker button usage is as follows:

No Button Pressed = 0000 No Operator Control Request
Manual Button Pressed = 0010 Manual Operator Control Request
Auto Button Pressed = 0011 Automatic Operator Control Request

3. The momentary contact button pair may be used, where the default is no buttons being pressed. The user can press the manual button, and when pressure is released, it will return to the no button pressed position. The user may press the auto button, and when pressure is released, it will return to the no button pressed position. Momentary contact buttons (button pair) usage is as follows:

No Button Pressed = 0000 No Operator Control Request
Manual Button Pressed = 0010 Manual Operator Control Request
Auto Button Pressed = 0011 Automatic Operator Control Request

4. The momentary contact single button may be used, where the default is no button being pressed. The user can press the button, which is the button pressed position, and when pressure is released, it will return to the no button pressed position. The controller receiving this command will keep track of what mode the blade is in, auto or manual. If the blade is in manual mode to begin with, one press of the button will change to mode to auto. If the button is pressed again, the blade will be put into manual mode. Momentary contact button (single button) usage is as follows:

No Button Pressed = 0000 No Operator Control Request
Button Pressed = 0001 Momentary Operator Control Request

Data Values and Descriptions:

0000 No Operator Control Request
0001 Momentary Operator Control Request
0010 Manual Operator Control Request
0011 Automatic Operator Control Request
0100 - 1101 Reserved
1110 Error Indicator
1111 Not Installed

Data Length: 4 bits
Resolution: 16 states/4 bit, 0 offset
Data Range: 0 to 15 Operational Range: same as data range
Type: Measured
Supporting information:
PGN 61453

SPN 3340 Engine Charge Air Cooler 1 Inlet Pressure

Pressure of air at inlet to 1st or only charge air cooler, from multiple first stage turbochargers being cooled and feeding multiple second stage turbochargers.

Data Length: 1 byte
Resolution: 2 kPa/bit, 0 offset
Data Range: 0 to 500 kPa Operational Range: same as data range
Type: Measured
Supporting information:
PGN 64938

SPN 3341 Engine Charge Air Cooler 2 Inlet Pressure

Pressure of air at inlet to 2nd charge air cooler, from multiple first stage turbochargers being cooled and feeding multiple second stage turbochargers.

Data Length: 1 byte
Resolution: 2 kPa/bit, 0 offset
Data Range: 0 to 500 kPa Operational Range: same as data range
Type: Measured
Supporting information:
PGN 64938

SPN 3342 Engine Coolant Pump Differential Pressure

The differential pressure measured across the input and output of the engine coolant pump.

Data Length: 1 byte
Resolution: 1.64 kPa/bit, -7 kPa offset
Data Range: -7 to 403 kPa Operational Range: same as data range
Type: Measured
Supporting information:
PGN 64938

SPN 3343 Engine Centrifugal Oil Filter speed

The speed of a rotating (centrifugal) engine oil filter.

Data Length: 2 bytes
Resolution: 4 rpm/bit, 0 offset
Data Range: 0 to 257,020 rpm Operational Range: same as data range
Type: Measured
Supporting information:
PGN 64938

SPN 3344 Support Variable Rate TSC1 Message

This parameter indicates which TSC1 transmission rates are supported by the engine ECU in addition to the required 10ms transmission rate for temporary powertrain control purposes.

Bit Position	Transmission Rate
1	1000 ms transmission rate
2	750 ms transmission rate
3	500 ms transmission rate
4	250 ms transmission rate
5	100 ms transmission rate
6	50 ms transmission rate
7	20 ms transmission rate
8	Reserved for SAE assignment (set to one)

Where 0 = Transmission Rate Supported by Engine and 1 = Transmission Rate Not supported by Engine

Note: FF for this byte implies that the engine only supports standard temporary power train control (e.g. 10 ms)

Data Length:	8 bits	
Resolution:	256 states/8 bit, 0 offset	
Data Range:	0 to 255	Operational Range: same as data range
Type:	Status	
Supporting information:		
PGN	65251	

SPN 3345 Support TSC1 Control Purpose Group 1

This parameter indicates which TSC1 control purposes are supported in group 1 of 4. One bit is used to convey the support of each Control Purpose. A value of 0 equals supported and a value of 1 equals not supported. This bit logic is used to allow the default to FF to be backward compatible.

This group of 4 parameters (SPNs 3345, 3346, 3347, and 3348) indicates which TSC1 Control Purposes are supported by the engine ECU in addition to the Temporary Powertrain Control Purpose (which is denoted as control purpose P32). All ones in the Group 1 through 4 parameters indicates the engine only supports Temporary Powertrain Control.

Group 1 of 4

Bit Position	Control Purpose Value	Control Purpose Description
1	P1	Accelerator Pedal/Operator Selection
2	P2	Cruise Control
3	P3	PTO Governor
4	P4	Road Speed Governor
5	P5	Reserved for assignment by SAE
6	P6	Reserved for assignment by SAE
7	P7	Reserved for assignment by SAE
8	P8	Reserved for assignment by SAE

Where 0 = Control Purpose is supported and 1 = Control Purpose is not supported

Data Length:	8 bits	
Resolution:	256 states/8 bit, 0 offset	
Data Range:	0 to 255	Operational Range: same as data range
Type:	Status	
Supporting information:		
PGN	65251	

SPN 3346 Support TSC1 Control Purpose Group 2

This parameter indicates which TSC1 control purposes are supported in group 2 of 4. One bit is used to convey the support of each Control Purpose. A value of 0 equals supported and a value of 1 equals not supported. This bit logic is used to allow the default to FF to be backward compatible.

This group of 4 parameters (SPNs 3345, 3346, 3347, and 3348) indicates which TSC1 Control Purposes are supported by the engine ECU in addition to the Temporary Powertrain Control Purpose (which is denoted as control purpose P32). All ones in the Group 1 through 4 parameters indicates the engine only supports Temporary Powertrain Control.

Group 2 of 4

Bit Position	Control Purpose Value	Control Purpose Description
1	P9	Reserved for assignment by SAE
2	P10	Reserved for assignment by SAE
3	P11	Reserved for assignment by SAE
4	P12	Reserved for assignment by SAE
5	P13	Reserved for assignment by SAE
6	P14	Reserved for assignment by SAE
7	P15	Reserved for assignment by SAE
8	P16	Reserved for assignment by SAE

Where 0 = Control Purpose is supported and 1 = Control Purpose is not supported

Data Length: 8 bits
 Resolution: 256 states/8 bit, 0 offset
 Data Range: 0 to 255 Operational Range: same as data range
 Type: Status
 Supporting information:
 PGN 65251

SPN 3347 Support TSC1 Control Purpose Group 3

This parameter indicates which TSC1 control purposes are supported in group 3 of 4. One bit is used to convey the support of each Control Purpose. A value of 0 equals supported and a value of 1 equals not supported. This bit logic is used to allow the default to FF to be backward compatible.

This group of 4 parameters (SPNs 3345, 3346, 3347, and 3348) indicates which TSC1 Control Purposes are supported by the engine ECU in addition to the Temporary Powertrain Control Purpose (which is denoted as control purpose P32). All ones in the Group 1 through 4 parameters indicates the engine only supports Temporary Powertrain Control.

Group 3 of 4

Bit Position	Control Purpose Value	Control Purpose Description
1	P17	Reserved for assignment by SAE
2	P18	Reserved for assignment by SAE
3	P19	Reserved for assignment by SAE
4	P20	Reserved for assignment by SAE
5	P21	Reserved for assignment by SAE
6	P22	Reserved for assignment by SAE
7	P23	Reserved for assignment by SAE
8	P24	Reserved for assignment by SAE

Where 0 = Control Purpose is supported and 1 = Control Purpose is not supported

Data Length: 8 bits
 Resolution: 256 states/8 bit, 0 offset
 Data Range: 0 to 255 Operational Range: same as data range
 Type: Status
 Supporting information:
 PGN 65251

SPN 3348 Support TSC1 Control Purpose Group 4

This parameter indicates which TSC1 control purposes are supported in group 4 of 4. One bit is used to convey the support of each Control Purpose. A value of 0 equals supported and a value of 1 equals not supported. This bit logic is used to allow the default to FF to be backward compatible.

This group of 4 parameters (SPNs 3345, 3346, 3347, and 3348) indicates which TSC1 Control Purposes are supported by the engine ECU in addition to the Temporary Powertrain Control Purpose (which is denoted as control purpose P32). All ones in the Group 1 through 4 parameters indicates the engine only supports Temporary Powertrain Control.

Group 4 of 4

Bit Position	Control Purpose Value	Control Purpose Description
1	P25	Reserved for assignment by SAE
2	P26	Reserved for assignment by SAE
3	P27	Reserved for assignment by SAE
4	P28	Reserved for assignment by SAE
5	P29	Reserved for assignment by SAE
6	P30	Reserved for assignment by SAE
7	P31	Reserved for assignment by SAE
8	See Note	Not assignable, must always be set to 1.

Where 0 = Control Purpose is supported and 1 = Control Purpose is not supported

NOTE: P32 is always supported and is Temporary Power Train Control (the original use of the TSC1 Command). The engine configuration will not indicate separate support of Temporary Power Train Control mode.

Data Length: 8 bits
 Resolution: 256 states/8 bit, 0 offset
 Data Range: 0 to 255 Operational Range: same as data range
 Type: Status
 Supporting information:
 PGN 65251

SPN 3349 TSC1 Transmission Rate

This parameter indicates the transmission rate at which the sending device will transmit the TSC1 message. The engine shall adjust its timeout for TSC1 messages accordingly. Variable TSC1 transmission rates shall only apply to messages sent to the engine.

A value of all ones is to be used in TSC1 messages directed to retarders because the TSC1 Transmission Rate parameter is not applicable for retarders. All TSC1 messages sent to the retarder shall use the standard 50 ms rate.

Devices sending TSC1 messages to the engine should only invoke alternative transmission rates which the engine has indicated it supports in SPN 3344 – Support Variable Rate TSC1 Message.

000 = 1000 ms transmission rate
 001 = 750 ms transmission rate
 010 = 500 ms transmission rate
 011 = 250 ms transmission rate
 100 = 100 ms transmission rate
 101 = 50 ms transmission rate
 110 = 20 ms transmission rate
 111 = Use standard TSC1 transmission rates of 10 ms to engine

Note: Sending devices shall not send variable rate TSC1 messages to the engine for unsupported control purposes.

Data Length: 3 bits
 Resolution: 8 states/3 bit, 0 offset
 Data Range: 0 to 7 Operational Range: same as data range
 Type: Status
 Supporting information:
 PGN 0

SPN 3350 TSC1 Control Purpose

State signal which indicates which control mode the sending device is using to generate the TSC1 command. Note that the modes are not in prioritized order. Not all modes may be relevant for a given device. Some devices may not implement all functions. For typical priorities refer to Figures SPN512_A, SPN512_B for engine control and Figure SPN695_A. The TSC1 control purpose shall only apply to messages sent to the engine.

A value of all ones is to be used in TSC1 messages directed to retarders because the TSC1 Control Purpose parameter is not applicable for retarders.

00000 = P1 = Accelerator Pedal/Operator Selection
 00001 = P2 = Cruise Control
 00010 = P3 = PTO Governor
 00011 = P4 = Road Speed Governor
 00100 = P5 = Engine Protection
 00101 - 11110 = P6-P31 = Reserved for SAE Assignment
 11111 = P32 = Temporary Power Train Control (Original use of TSC1 Command)

Note: Sending devices shall not send variable rate TSC1 messages to the engine for unsupported control purposes.

Data Length: 5 bits
 Resolution: 32 states/5 bit, 0 offset
 Data Range: 0 to 31 Operational Range: same as data range
 Type: Status
 Supporting information:
 PGN 0

SPN 3353 Alternator 1 Status

Alternator 1 operating status.

00 Alternator 1 not charging
 01 Alternator 1 charging
 10 error
 11 not available

Data Length: 2 bits
 Resolution: 4 states/2 bit, 0 offset
 Data Range: 0 to 3 Operational Range: same as data range
 Type: Measured
 Supporting information:
 PGN 65237

SPN 3354 Alternator 2 Status

Alternator 2 operating status.

00 Alternator 2 not charging
 01 Alternator 2 charging
 10 error
 11 not available

Data Length: 2 bits
 Resolution: 4 states/2 bit, 0 offset
 Data Range: 0 to 3 Operational Range: same as data range
 Type: Measured
 Supporting information:
 PGN 65237

SPN 3355 Alternator 3 Status

Alternator 3 operating status.

00 Alternator 3 not charging
 01 Alternator 3 charging
 10 error
 11 not available

Data Length: 2 bits
 Resolution: 4 states/2 bit, 0 offset
 Data Range: 0 to 3 Operational Range: same as data range
 Type: Measured
 Supporting information:
 PGN 65237

SPN 3356 Alternator 4 Status

Alternator 4 operating status.

00 Alternator 4 not charging
 01 Alternator 4 charging
 10 error
 11 not available

Data Length: 2 bits
 Resolution: 4 states/2 bit, 0 offset
 Data Range: 0 to 3 Operational Range: same as data range
 Type: Measured
 Supporting information:
 PGN 65237

SPN 3357 Actual Maximum Available Engine - Percent Torque

This is the maximum amount of torque that the engine can immediately deliver as a percentage of the reference engine torque (SPN 544). The Actual Maximum Available Engine - Percent Torque shall take into consideration all engine torque derates (e.g. air fuel ratio control (AFC), noise control, etc.) that could potentially be active in the system. This parameter differentiates itself from the engine percent torque points 1 through 5 of the engine configuration map because it takes into account all dynamic internal inputs such as AFC and that it is updated on a 50ms basis.

Data Length: 1 byte
 Resolution: 0.4 %/bit, 0 offset
 Data Range: 0 to 100 % Operational Range: same as data range
 Type: Measured
 Supporting information:
 PGN 61443

SPN 3358 Engine Exhaust Gas Recirculation Inlet Pressure

EGR inlet gage pressure is measured after the EGR cooler and before the EGR valve.

Data Length: 1 byte
 Resolution: 2 kPa/bit, 0 offset
 Data Range: 0 to 500 kPa Operational Range: same as data range
 Type: Measured
 Supporting information:
 PGN 64961

SPN 3359 *Transmission Oil Filter Restriction Switch*

This switch indicates whether the transmission oil filter is clogged.

00 - No restriction
01 - Restriction exists on oil filter
10 - Error
11 - Not available

Data Length: 2 bits
Resolution: 4 states/2 bit, 0 offset
Data Range: 0 to 3 Operational Range: same as data range
Type: Status
Supporting information:
PGN 64917

SPN 3365 *Relative Blade Height*

The measured vertical distance from a fixed location on the machine blade to a ground-based reference (i.e. relative height). Examples of a ground based reference include a curb, a stringline or the ground itself. The measurement may be positive or negative based on the initial reference used.

Data Length: 2 bytes
Resolution: 0.1 mm/bit, -3,200 mm offset
Data Range: -3,200 to 3,225.5 mm Operational Range: same as data range
Type: Measured
Supporting information:
PGN 61460

SPN 3366 *Relative Blade Height and Blade Rotation Angle Measurement Latency*

The estimated measurement latency of the measurement.

NOTE: This is only the sensor latency and does not include any additional latencies that might exist because of the CAN Bus or overall system implementation.

For example, if the technique used is a sonic pulse/echo system, the round trip time divided by two will be a reasonably accurate estimate of the measurement latency if the processing time is small with respect to the propagation time.

Data Length: 1 byte
Resolution: 0.5 ms/bit, 0 offset
Data Range: 0 to 125 ms Operational Range: same as data range
Type: Measured
Supporting information:
PGN 61460

SPN 3367 *Relative Blade Height Figure of Merit*

Figure of merit for blade height measurement.

Bits

- 00 Relative Blade Height fully functional. Data is within sensor specification.
- 01 Relative Blade Height degraded. Data is suspect due to environmental conditions.
- 10 Relative Blade Height failed.
- 11 Relative Blade Height not available

Data Length: 2 bits
Resolution: 4 states/2 bit, 0 offset
Data Range: 0 to 3 Operational Range: same as data range
Type: Status
Supporting information:
PGN 61460

SPN 3368 *Network Transceiver Status 1*

Indicates the status of the transceiver for the wireless communications network type

- 0 = Off
- 1 = On
- 2 = Not Authorized to Operate on Network
- 3-250 = Reserved for Future Assignment
- 251-253 = Reserved
- 254 = Error
- 255 = Not Available

Data Length: 8 bits
Resolution: 256 states/8 bit, 0 offset
Data Range: 0 to 255 Operational Range: same as data range
Type: Status
Supporting information:
PGN 64937

SPN 3369 *Network Service Status 1*

Indicates the status of the Service for the wireless communications network type

- 0 = Local Service
- 1 = Roaming Service
- 2 = Service not available
- 3 = Not Authorized to Operate on Service
- 4-250 = Reserved for Future Assignment
- 251-253 = Reserved
- 254 = Error
- 255 = Not Available

Data Length: 8 bits
Resolution: 256 states/8 bit, 0 offset
Data Range: 0 to 255 Operational Range: same as data range
Type: Status
Supporting information:
PGN 64937

SPN 3370 Network Antenna Status 1

Indicates the status of the antenna for the wireless communications network type

0 = Off
1 = On
2-250 = Reserved for Future Assignment
251-253 = Reserved
254 = Error
255 = Not Available

Data Length: 8 bits
Resolution: 256 states/8 bit, 0 offset
Data Range: 0 to 255 Operational Range: same as data range
Type: Status
Supporting information:
PGN 64937

SPN 3371 Network Signal Strength 1

Indicates the signal strength for the wireless communications network type.

Data Length: 1 byte
Resolution: 0.4 %/bit, 0 offset
Data Range: 0 to 100 % Operational Range: same as data range
Type: Status
Supporting information:
PGN 64937

SPN 3372 Wireless Communication Network Type 1

Type of Wireless Communication Network

0 = Cellular network #1
1 = Cellular network #2
2 = Wireless LAN #1
3 = Wireless LAN #2
4 = Satellite network
5-250 = Reserved for Future Assignment
251-253 = Reserved
254 = Error
255 = Not Available

Data Length: 8 bits
Resolution: 256 states/8 bit, 0 offset
Data Range: 0 to 255 Operational Range: same as data range
Type: Status
Supporting information:
PGN 64937

SPN 3387 Engine Cylinder 1 Combustion Status

This parameter is used to indicate state of combustion in engine cylinder #1

00 No combustion
01 Combustion exists
10 Error
11 Not available

Data Length: 2 bits
Resolution: 4 states/2 bit, 0 offset
Data Range: 0 to 3 Operational Range: same as data range
Type: Status
Supporting information:
PGN 61462

SPN 3388 Engine Cylinder 2 Combustion Status

This parameter is used to indicate state of combustion in engine cylinder #2

00 No combustion
01 Combustion exists
10 Error
11 Not available

Data Length: 2 bits
Resolution: 4 states/2 bit, 0 offset
Data Range: 0 to 3 Operational Range: same as data range
Type: Status
Supporting information:
PGN 61462

SPN 3389 Engine Cylinder 3 Combustion Status

This parameter is used to indicate state of combustion in engine cylinder #3

00 No combustion
01 Combustion exists
10 Error
11 Not available

Data Length: 2 bits
Resolution: 4 states/2 bit, 0 offset
Data Range: 0 to 3 Operational Range: same as data range
Type: Status
Supporting information:
PGN 61462

SPN 3390 Engine Cylinder 4 Combustion Status

This parameter is used to indicate state of combustion in engine cylinder #4

00 No combustion
01 Combustion exists
10 Error
11 Not available

Data Length: 2 bits
Resolution: 4 states/2 bit, 0 offset
Data Range: 0 to 3 Operational Range: same as data range
Type: Status
Supporting information:
PGN 61462

SPN 3391 Engine Cylinder 5 Combustion Status

This parameter is used to indicate state of combustion in engine cylinder #5

00 No combustion
01 Combustion exists
10 Error
11 Not available

Data Length: 2 bits
Resolution: 4 states/2 bit, 0 offset
Data Range: 0 to 3 Operational Range: same as data range
Type: Status
Supporting information:
PGN 61462

SPN 3392 Engine Cylinder 6 Combustion Status

This parameter is used to indicate state of combustion in engine cylinder #6

00 No combustion
01 Combustion exists
10 Error
11 Not available

Data Length: 2 bits
Resolution: 4 states/2 bit, 0 offset
Data Range: 0 to 3 Operational Range: same as data range
Type: Status
Supporting information:
PGN 61462

SPN 3393 Engine Cylinder 7 Combustion Status

This parameter is used to indicate state of combustion in engine cylinder #7

00 No combustion
01 Combustion exists
10 Error
11 Not available

Data Length: 2 bits
Resolution: 4 states/2 bit, 0 offset
Data Range: 0 to 3 Operational Range: same as data range
Type: Status
Supporting information:
PGN 61462

SPN 3394 Engine Cylinder 8 Combustion Status

This parameter is used to indicate state of combustion in engine cylinder #8

00 No combustion
01 Combustion exists
10 Error
11 Not available

Data Length: 2 bits
Resolution: 4 states/2 bit, 0 offset
Data Range: 0 to 3 Operational Range: same as data range
Type: Status
Supporting information:
PGN 61462

SPN 3395 Engine Cylinder 9 Combustion Status

This parameter is used to indicate state of combustion in engine cylinder #9

00 No combustion
01 Combustion exists
10 Error
11 Not available

Data Length: 2 bits
Resolution: 4 states/2 bit, 0 offset
Data Range: 0 to 3 Operational Range: same as data range
Type: Status
Supporting information:
PGN 61462

SPN 3396 Engine Cylinder 10 Combustion Status

This parameter is used to indicate state of combustion in engine cylinder #10

00 No combustion
01 Combustion exists
10 Error
11 Not available

Data Length: 2 bits
Resolution: 4 states/2 bit, 0 offset
Data Range: 0 to 3 Operational Range: same as data range
Type: Status
Supporting information:
PGN 61462

SPN 3397 Engine Cylinder 11 Combustion Status

This parameter is used to indicate state of combustion in engine cylinder #11

00 No combustion
01 Combustion exists
10 Error
11 Not available

Data Length: 2 bits
Resolution: 4 states/2 bit, 0 offset
Data Range: 0 to 3 Operational Range: same as data range
Type: Status
Supporting information:
PGN 61462

SPN 3398 Engine Cylinder 12 Combustion Status

This parameter is used to indicate state of combustion in engine cylinder #12

00 No combustion
01 Combustion exists
10 Error
11 Not available

Data Length: 2 bits
Resolution: 4 states/2 bit, 0 offset
Data Range: 0 to 3 Operational Range: same as data range
Type: Status
Supporting information:
PGN 61462

SPN 3399 Engine Cylinder 13 Combustion Status

This parameter is used to indicate state of combustion in engine cylinder #13

00 No combustion
01 Combustion exists
10 Error
11 Not available

Data Length: 2 bits
Resolution: 4 states/2 bit, 0 offset
Data Range: 0 to 3 Operational Range: same as data range
Type: Status
Supporting information:
PGN 61462

SPN 3400 Engine Cylinder 14 Combustion Status

This parameter is used to indicate state of combustion in engine cylinder #14

00 No combustion
01 Combustion exists
10 Error
11 Not available

Data Length: 2 bits
Resolution: 4 states/2 bit, 0 offset
Data Range: 0 to 3 Operational Range: same as data range
Type: Status
Supporting information:
PGN 61462

SPN 3401 Engine Cylinder 15 Combustion Status

This parameter is used to indicate state of combustion in engine cylinder #15

00 No combustion
01 Combustion exists
10 Error
11 Not available

Data Length: 2 bits
Resolution: 4 states/2 bit, 0 offset
Data Range: 0 to 3 Operational Range: same as data range
Type: Status
Supporting information:
PGN 61462

SPN 3402 Engine Cylinder 16 Combustion Status

This parameter is used to indicate state of combustion in engine cylinder #16

00 No combustion
01 Combustion exists
10 Error
11 Not available

Data Length: 2 bits

Resolution: 4 states/2 bit, 0 offset

Data Range: 0 to 3

Operational Range: same as data range

Type: Status

Supporting information:

PGN 61462

SPN 3403 Engine Cylinder 17 Combustion Status

This parameter is used to indicate state of combustion in engine cylinder #17

00 No combustion
01 Combustion exists
10 Error
11 Not available

Data Length: 2 bits

Resolution: 4 states/2 bit, 0 offset

Data Range: 0 to 3

Operational Range: same as data range

Type: Status

Supporting information:

PGN 61462

SPN 3404 Engine Cylinder 18 Combustion Status

This parameter is used to indicate state of combustion in engine cylinder #18

00 No combustion
01 Combustion exists
10 Error
11 Not available

Data Length: 2 bits

Resolution: 4 states/2 bit, 0 offset

Data Range: 0 to 3

Operational Range: same as data range

Type: Status

Supporting information:

PGN 61462

SPN 3405 Engine Cylinder 19 Combustion Status

This parameter is used to indicate state of combustion in engine cylinder #19

00 No combustion
01 Combustion exists
10 Error
11 Not available

Data Length: 2 bits
Resolution: 4 states/2 bit, 0 offset
Data Range: 0 to 3 Operational Range: same as data range
Type: Status
Supporting information:
PGN 61462

SPN 3406 Engine Cylinder 20 Combustion Status

This parameter is used to indicate state of combustion in engine cylinder #20

00 No combustion
01 Combustion exists
10 Error
11 Not available

Data Length: 2 bits
Resolution: 4 states/2 bit, 0 offset
Data Range: 0 to 3 Operational Range: same as data range
Type: Status
Supporting information:
PGN 61462

SPN 3407 Engine Cylinder 21 Combustion Status

This parameter is used to indicate state of combustion in engine cylinder #21

00 No combustion
01 Combustion exists
10 Error
11 Not available

Data Length: 2 bits
Resolution: 4 states/2 bit, 0 offset
Data Range: 0 to 3 Operational Range: same as data range
Type: Status
Supporting information:
PGN 61462

SPN 3408 Engine Cylinder 22 Combustion Status

This parameter is used to indicate state of combustion in engine cylinder #22

00 No combustion
01 Combustion exists
10 Error
11 Not available

Data Length: 2 bits

Resolution: 4 states/2 bit, 0 offset

Data Range: 0 to 3

Operational Range: same as data range

Type: Status

Supporting information:

PGN 61462

SPN 3409 Engine Cylinder 23 Combustion Status

This parameter is used to indicate state of combustion in engine cylinder #23

00 No combustion
01 Combustion exists
10 Error
11 Not available

Data Length: 2 bits

Resolution: 4 states/2 bit, 0 offset

Data Range: 0 to 3

Operational Range: same as data range

Type: Status

Supporting information:

PGN 61462

SPN 3410 Engine Cylinder 24 Combustion Status

This parameter is used to indicate state of combustion in engine cylinder #24

00 No combustion
01 Combustion exists
10 Error
11 Not available

Data Length: 2 bits

Resolution: 4 states/2 bit, 0 offset

Data Range: 0 to 3

Operational Range: same as data range

Type: Status

Supporting information:

PGN 61462

SPN 3411 Status 2 of doors

Composite indication of all bus door statuses. Enabled means the bus doors are able to be automatically opened or closed.

00 all bus doors are disabled
01 at least 1 bus door enabled
10 error
11 not available

Data Length: 2 bits
Resolution: 4 states/2 bit, 0 offset
Data Range: 0 to 3 Operational Range: same as data range
Type: Measured
Supporting information:
PGN 65102

SPN 3412 Lock Status of Door 1

Lock status of bus door 1

00 unlocked
01 locked
10 error
11 not available

Data Length: 2 bits
Resolution: 4 states/2 bit, 0 offset
Data Range: 0 to 3 Operational Range: same as data range
Type: Measured
Supporting information:
PGN 64933

SPN 3413 Open Status of Door 1

Open status of bus door 1

00 door closed
01 door opened
10 error
11 not available

Data Length: 2 bits
Resolution: 4 states/2 bit, 0 offset
Data Range: 0 to 3 Operational Range: same as data range
Type: Measured
Supporting information:
PGN 64933

SPN 3414 *Enable Status of Door 1*

Enable status of bus door 1. Enabled means the bus doors are able to be automatically opened or closed.

00 door disabled
01 door enabled
10 error
11 not available

Data Length: 2 bits
Resolution: 4 states/2 bit, 0 offset
Data Range: 0 to 3 Operational Range: same as data range
Type: Measured
Supporting information:
PGN 64933

SPN 3415 *Lock Status of Door 2*

Lock status of bus door 2

00 unlocked
01 locked
10 error
11 not available

Data Length: 2 bits
Resolution: 4 states/2 bit, 0 offset
Data Range: 0 to 3 Operational Range: same as data range
Type: Measured
Supporting information:
PGN 64933

SPN 3416 *Open Status of Door 2*

Open status of bus door 2

00 door closed
01 door opened
10 error
11 not available

Data Length: 2 bits
Resolution: 4 states/2 bit, 0 offset
Data Range: 0 to 3 Operational Range: same as data range
Type: Measured
Supporting information:
PGN 64933

SPN 3417 *Enable Status of Door 2*

Enable status of bus door 2. Enabled means the bus doors are able to be automatically opened or closed.

00 door disabled
01 door enabled
10 error
11 not available

Data Length: 2 bits
Resolution: 4 states/2 bit, 0 offset
Data Range: 0 to 3 Operational Range: same as data range
Type: Measured
Supporting information:
PGN 64933

SPN 3418 *Lock Status of Door 3*

Lock status of bus door 3

00 unlocked
01 locked
10 error
11 not available

Data Length: 2 bits
Resolution: 4 states/2 bit, 0 offset
Data Range: 0 to 3 Operational Range: same as data range
Type: Measured
Supporting information:
PGN 64933

SPN 3419 *Open Status of Door 3*

Open status of bus door 3

00 door closed
01 door opened
10 error
11 not available

Data Length: 2 bits
Resolution: 4 states/2 bit, 0 offset
Data Range: 0 to 3 Operational Range: same as data range
Type: Measured
Supporting information:
PGN 64933

SPN 3420 Enable Status of Door 3

Enable status of bus door 3. Enabled means the bus doors are able to be automatically opened or closed.

00 door disabled
01 door enabled
10 error
11 not available

Data Length: 2 bits
Resolution: 4 states/2 bit, 0 offset
Data Range: 0 to 3 Operational Range: same as data range
Type: Measured
Supporting information:
PGN 64933

SPN 3421 Lock Status of Door 4

Lock status of bus door 4

00 unlocked
01 locked
10 error
11 not available

Data Length: 2 bits
Resolution: 4 states/2 bit, 0 offset
Data Range: 0 to 3 Operational Range: same as data range
Type: Measured
Supporting information:
PGN 64933

SPN 3422 Open Status of Door 4

Open status of bus door 4

00 door closed
01 door opened
10 error
11 not available

Data Length: 2 bits
Resolution: 4 states/2 bit, 0 offset
Data Range: 0 to 3 Operational Range: same as data range
Type: Measured
Supporting information:
PGN 64933

SPN 3423 *Enable Status of Door 4*

Enable status of bus door 4. Enabled means the bus doors are able to be automatically opened or closed.

00 door disabled
01 door enabled
10 error
11 not available

Data Length: 2 bits
Resolution: 4 states/2 bit, 0 offset
Data Range: 0 to 3 Operational Range: same as data range
Type: Measured
Supporting information:
PGN 64933

SPN 3424 *Lock Status of Door 5*

Lock status of bus door 5

00 unlocked
01 locked
10 error
11 not available

Data Length: 2 bits
Resolution: 4 states/2 bit, 0 offset
Data Range: 0 to 3 Operational Range: same as data range
Type: Measured
Supporting information:
PGN 64933

SPN 3425 *Open Status of Door 5*

Open status of bus door 5

00 door closed
01 door opened
10 error
11 not available

Data Length: 2 bits
Resolution: 4 states/2 bit, 0 offset
Data Range: 0 to 3 Operational Range: same as data range
Type: Measured
Supporting information:
PGN 64933

SPN 3426 *Enable Status of Door 5*

Enable status of bus door 5. Enabled means the bus doors are able to be automatically opened or closed.

00 door disabled
01 door enabled
10 error
11 not available

Data Length: 2 bits
Resolution: 4 states/2 bit, 0 offset
Data Range: 0 to 3 Operational Range: same as data range
Type: Measured
Supporting information:
PGN 64933

SPN 3427 *Lock Status of Door 6*

Lock status of bus door 6

00 unlocked
01 locked
10 error
11 not available

Data Length: 2 bits
Resolution: 4 states/2 bit, 0 offset
Data Range: 0 to 3 Operational Range: same as data range
Type: Measured
Supporting information:
PGN 64933

SPN 3428 *Open Status of Door 6*

Open status of bus door 6

00 door closed
01 door opened
10 error
11 not available

Data Length: 2 bits
Resolution: 4 states/2 bit, 0 offset
Data Range: 0 to 3 Operational Range: same as data range
Type: Measured
Supporting information:
PGN 64933

SPN 3429 *Enable Status of Door 6*

Enable status of bus door 6. Enabled means the bus doors are able to be automatically opened or closed.

00 door disabled
01 door enabled
10 error
11 not available

Data Length: 2 bits
Resolution: 4 states/2 bit, 0 offset
Data Range: 0 to 3 Operational Range: same as data range
Type: Measured
Supporting information:
PGN 64933

SPN 3430 *Lock Status of Door 7*

Lock status of bus door 7

00 unlocked
01 locked
10 error
11 not available

Data Length: 2 bits
Resolution: 4 states/2 bit, 0 offset
Data Range: 0 to 3 Operational Range: same as data range
Type: Measured
Supporting information:
PGN 64933

SPN 3431 *Open Status of Door 7*

Open status of bus door 7

00 door closed
01 door opened
10 error
11 not available

Data Length: 2 bits
Resolution: 4 states/2 bit, 0 offset
Data Range: 0 to 3 Operational Range: same as data range
Type: Measured
Supporting information:
PGN 64933

SPN 3432 *Enable Status of Door 7*

Enable status of bus door 7. Enabled means the bus doors are able to be automatically opened or closed.

00 door disabled
01 door enabled
10 error
11 not available

Data Length: 2 bits
Resolution: 4 states/2 bit, 0 offset
Data Range: 0 to 3 Operational Range: same as data range
Type: Measured
Supporting information:
PGN 64933

SPN 3433 *Lock Status of Door 8*

Lock status of bus door 8

00 unlocked
01 locked
10 error
11 not available

Data Length: 2 bits
Resolution: 4 states/2 bit, 0 offset
Data Range: 0 to 3 Operational Range: same as data range
Type: Measured
Supporting information:
PGN 64933

SPN 3434 *Open Status of Door 8*

Open status of bus door 8

00 door closed
01 door opened
10 error
11 not available

Data Length: 2 bits
Resolution: 4 states/2 bit, 0 offset
Data Range: 0 to 3 Operational Range: same as data range
Type: Measured
Supporting information:
PGN 64933

SPN 3435 *Enable Status of Door 8*

Enable status of bus door 8. Enabled means the bus doors are able to be automatically opened or closed.

00 door disabled
01 door enabled
10 error
11 not available

Data Length: 2 bits
Resolution: 4 states/2 bit, 0 offset
Data Range: 0 to 3 Operational Range: same as data range
Type: Measured
Supporting information:
PGN 64933

SPN 3436 *Lock Status of Door 9*

Lock status of bus door 9

00 unlocked
01 locked
10 error
11 not available

Data Length: 2 bits
Resolution: 4 states/2 bit, 0 offset
Data Range: 0 to 3 Operational Range: same as data range
Type: Measured
Supporting information:
PGN 64933

SPN 3437 *Open Status of Door 9*

Open status of bus door 9

00 door closed
01 door opened
10 error
11 not available

Data Length: 2 bits
Resolution: 4 states/2 bit, 0 offset
Data Range: 0 to 3 Operational Range: same as data range
Type: Measured
Supporting information:
PGN 64933

SPN 3438 *Enable Status of Door 9*

Enable status of bus door 9. Enabled means the bus doors are able to be automatically opened or closed.

00 door disabled
01 door enabled
10 error
11 not available

Data Length: 2 bits
Resolution: 4 states/2 bit, 0 offset
Data Range: 0 to 3 Operational Range: same as data range
Type: Measured
Supporting information:
PGN 64933

SPN 3439 *Lock Status of Door 10*

Lock status of bus door 10

00 unlocked
01 locked
10 error
11 not available

Data Length: 2 bits
Resolution: 4 states/2 bit, 0 offset
Data Range: 0 to 3 Operational Range: same as data range
Type: Measured
Supporting information:
PGN 64933

SPN 3440 *Open Status of Door 10*

Open status of bus door 10

00 door closed
01 door opened
10 error
11 not available

Data Length: 2 bits
Resolution: 4 states/2 bit, 0 offset
Data Range: 0 to 3 Operational Range: same as data range
Type: Measured
Supporting information:
PGN 64933

SPN 3441 Enable Status of Door 10

Enable status of bus door 10. Enabled means the bus doors are able to be automatically opened or closed.

00 door disabled
01 door enabled
10 error
11 not available

Data Length: 2 bits
Resolution: 4 states/2 bit, 0 offset
Data Range: 0 to 3 Operational Range: same as data range
Type: Measured
Supporting information:
PGN 64933

SPN 3442 Network Transceiver Status 2

Indicates the status of the transceiver for the wireless communications network type

0 = Off
1 = On
2 = Not Authorized to Operate on Network
3-250 = Reserved for Future Assignment
251-253 = Reserved
254 = Error
255 = Not Available

Data Length: 8 bits
Resolution: 256 states/8 bit, 0 offset
Data Range: 0 to 255 Operational Range: same as data range
Type: Status
Supporting information:
PGN 64936

SPN 3443 Network Service Status 2

Indicates the status of the Service for the wireless communications network type

0 = Local Service
1 = Roaming Service
2 = Service not available
3 = Not Authorized to Operate on Service
4-250 = Reserved for Future Assignment
251-253 = Reserved
254 = Error
255 = Not Available

Data Length: 8 bits
Resolution: 256 states/8 bit, 0 offset
Data Range: 0 to 255 Operational Range: same as data range
Type: Status
Supporting information:
PGN 64936

SPN 3444 Network Antenna Status 2

Indicates the status of the antenna for the wireless communications network type

0 = Off
1 = On
2-250 = Reserved for Future Assignment
251-253 = Reserved
254 = Error
255 = Not Available

Data Length: 8 bits
Resolution: 256 states/8 bit, 0 offset
Data Range: 0 to 255 Operational Range: same as data range
Type: Status
Supporting information:
PGN 64936

SPN 3445 Network Signal Strength 2

Indicates the signal strength for the wireless communications network type.

Data Length: 1 byte
Resolution: 0.4 %/bit, 0 offset
Data Range: 0 to 100 % Operational Range: same as data range
Type: Status
Supporting information:
PGN 64936

SPN 3446 Wireless Communication Network Type 2

Type of Wireless Communication Network

0 = Cellular network #1
1 = Cellular network #2
2 = Wireless LAN #1
3 = Wireless LAN #2
4 = Satellite network
5-250 = Reserved for Future Assignment
251-253 = Reserved
254 = Error
255 = Not Available

Data Length: 8 bits
Resolution: 256 states/8 bit, 0 offset
Data Range: 0 to 255 Operational Range: same as data range
Type: Status
Supporting information:
PGN 64936

SPN 3447 (R) Remote PTO Governor Preprogrammed Speed Control Switch #2

Switch signal which indicates that the remote PTO governor toggle switch #2 is in the enabled (ON) position. If the toggle switch is enabled and other conditions are satisfied then the remote PTO governor control feature is activated and the PTO governor will control at the preprogrammed speed #2.

00 - Off
01 - On
10 - Error
11 - Not Available

Note: This switch is different than the 1-8 Preprogrammed Set Speeds because this is a physical switch input, not a user programmable set speed (although the associated PTO set speed for this toggle switch is user defined).

Data Length: 2 bits
Resolution: 4 states/2 bit, 0 offset
Data Range: 0 to 3 Operational Range: same as data range
Type: Measured
Supporting information:
PGN 65264

SPN 3448 Auxiliary Input Ignore Switch

Switch signal which overrides other switch input's ability to disable an engine's operating condition.

00 - Off
01 - On
10 - Error
11 - Not Available

This switch input can be used to prevent the PTO from disengaging if another switch input's state changes. For example, if the PTO is normally disengaged when the clutch is depressed, then this switch would allow the user to use PTO while depressing the clutch.

Data Length: 2 bits
Resolution: 4 states/2 bit, 0 offset
Data Range: 0 to 3 Operational Range: same as data range
Type: Measured
Supporting information:
PGN 65264

SPN 3452 Enable Switch – Transmission input shaft PTO 1

Status of the operator's switch or other input which indicates the desire for engaging the first PTO drive mounted on the transmission case. There may be more than one PTO drive mounted on the transmission case.

00 Enable switch off – PTO operation not desired
01 Enable switch on – PTO operation desired
10 Error
11 Not available

Data Length: 2 bits
Resolution: 4 states/2 bit, 0 offset
Data Range: 0 to 3 Operational Range: same as data range
Type: Status
Supporting information:
PGN 64932

SPN 3453 *Enable Switch – Transmission input shaft PTO 2*

Status of the operator's switch or other input which indicates the desire for engaging the second PTO drive mounted on the transmission case. If there is only one PTO drive on the transmission case, use SPN 3452 Enable Switch – Transmission input shaft PTO 1.

00 Enable switch off – PTO operation not desired
01 Enable switch off – PTO operation desired
10 Error
11 Not available

Data Length: 2 bits
Resolution: 4 states/2 bit, 0 offset
Data Range: 0 to 3 Operational Range: same as data range
Type: Status
Supporting information:
PGN 64932

SPN 3454 *Enable Switch – Transmission output shaft PTO*

Status of the operator's switch or other input which indicates the desire for engaging the PTO drive mounted on the transmission output shaft.

00 Enable switch off – PTO operation not desired
01 Enable switch off – PTO operation desired
10 Error
11 Not available

Data Length: 2 bits
Resolution: 4 states/2 bit, 0 offset
Data Range: 0 to 3 Operational Range: same as data range
Type: Status
Supporting information:
PGN 64932

SPN 3455 *Enable Switch – Transfer case output shaft PTO*

Status of the operator's switch or other input which indicates the desire for engaging the PTO drive mounted on the output shaft of the transfer case.

00 Enable switch off – PTO operation not desired
01 Enable switch off – PTO operation desired
10 Error
11 Not available

Data Length: 2 bits
Resolution: 4 states/2 bit, 0 offset
Data Range: 0 to 3 Operational Range: same as data range
Type: Status
Supporting information:
PGN 64932

SPN 3456 Engagement Consent – Transmission input shaft PTO 1

Status of the transmission controller's consent to engage the first or sole PTO drive mounted on the transmission case. The controller in charge of the PTO drive should monitor this parameter and only engage the drive when consent is given. If consent is removed, while the PTO drive is engaged, the drive controller should disengage the drive as soon as possible.

Engaging the drive or continuing drive engagement when consent is removed may result in damage to the transmission and / or the PTO drive mechanism.

00 Consent not given – PTO drive should not be engaged
 01 Consent given – PTO drive may be engaged
 10 Error
 11 Not available

Data Length: 2 bits
 Resolution: 4 states/2 bit, 0 offset
 Data Range: 0 to 3 Operational Range: same as data range
 Type: Status
 Supporting information:
 PGN 64932

SPN 3457 Engagement Consent – Transmission input shaft PTO 2

Status of the transmission controller's consent to engage the second PTO drive mounted on the transmission case. The controller in charge of the PTO drive should monitor this parameter and only engage the drive when consent is given. If consent is removed while the PTO drive is engaged, the drive controller should disengage the drive as soon as possible. Engaging the drive or continuing drive engagement when consent is removed may result in damage to the transmission and / or the PTO drive mechanism. If there is only one PTO drive on the transmission case, use SPN 3456 Engagement Consent – Transmission input shaft PTO 1.

00 Consent not given – PTO drive should not be engaged
 01 Consent given – PTO drive may be engaged
 10 Error
 11 Not available

Data Length: 2 bits
 Resolution: 4 states/2 bit, 0 offset
 Data Range: 0 to 3 Operational Range: same as data range
 Type: Status
 Supporting information:
 PGN 64932

SPN 3458 Engagement Consent – Transmission output shaft PTO

Status of the transmission controller's consent to engage the PTO drive connected to the transmission output shaft. The controller in charge of the PTO drive should monitor this parameter and only engage the drive when consent is given. If consent is removed, while the PTO drive is engaged, the drive controller should disengage the drive as soon as possible. Engaging the drive or continuing drive engagement when consent is removed may result in damage to the transmission and / or the PTO drive mechanism.

00 Consent not given – PTO drive should not be engaged
 01 Consent given – PTO drive may be engaged
 10 Error
 11 Not available

Data Length: 2 bits
 Resolution: 4 states/2 bit, 0 offset
 Data Range: 0 to 3 Operational Range: same as data range
 Type: Status
 Supporting information:
 PGN 64932

SPN 3459 Engagement Consent – Transfer case output shaft PTO

Status of the transmission controller's consent to engage the PTO drive connected to the transfer case output shaft. The controller in charge of the PTO drive should monitor this parameter and only engage the drive when consent is given. If consent is removed, while the PTO drive is engaged, the drive controller should disengage the drive as soon as possible. Engaging the drive or continuing drive engagement when consent is removed may result in damage to the transmission and / or the PTO drive mechanism.

00 Consent not given – PTO drive should not be engaged
01 Consent given – PTO drive may be engaged
10 Error
11 Not available

Data Length: 2 bits
Resolution: 4 states/2 bit, 0 offset
Data Range: 0 to 3 Operational Range: same as data range
Type: Status
Supporting information:
PGN 64932

SPN 3460 Engagement Status – Transmission input shaft PTO 1

Reports if this specific PTO drive is engaged. This parameter should be broadcast only by the controller(s) receiving feedback about the specific drive.

For example, a pressure switch may be used to determine if a PTO-driven pump has been engaged. If the Body Controller (SA33) were monitoring this feedback signal, it should be the node broadcasting this parameter.

00 Drive not engaged
01 Drive is engaged
10 Error
11 Not available

Data Length: 2 bits
Resolution: 4 states/2 bit, 0 offset
Data Range: 0 to 3 Operational Range: same as data range
Type: Status
Supporting information:
PGN 64932

SPN 3461 Engagement Status – Transmission input shaft PTO 2

Reports if this specific PTO drive is engaged. This parameter should be broadcast only by the controller(s) receiving feedback about the specific drive.

For example, a pressure switch may be used to determine if a PTO-driven pump has been engaged. If the Body Controller (SA33) were monitoring this feedback signal, it should be the node broadcasting this parameter.

If there is only one PTO drive on the transmission case, SPN 3460 Engagement Status – Transmission input shaft PTO 1 should be used.

00 Drive not engaged
01 Drive is engaged
10 Error
11 Not available

Data Length: 2 bits

Resolution: 4 states/2 bit, 0 offset

Data Range: 0 to 3

Operational Range: same as data range

Type: Status

Supporting information:

PGN 64932

SPN 3462 Engagement Status – Transmission output shaft PTO

Reports if this specific PTO drive is engaged. This parameter should be broadcast only by the controller(s) receiving feedback about the specific drive.

For example, a pressure switch may be used to determine if a PTO-driven pump has been engaged. If the Body Controller (SA33) were monitoring this feedback signal, it should be the node broadcasting this parameter.

00 Drive not engaged
01 Drive is engaged
10 Error
11 Not available

Data Length: 2 bits

Resolution: 4 states/2 bit, 0 offset

Data Range: 0 to 3

Operational Range: same as data range

Type: Status

Supporting information:

PGN 64932

SPN 3463 Engagement Status – Transfer case output shaft PTO

Reports if this specific PTO drive is engaged. This parameter should be broadcast only by the controller(s) receiving feedback about the specific drive.

For example, a pressure switch may be used to determine if a PTO-driven pump has been engaged. If the Body Controller (SA33) were monitoring this feedback signal, it should be the node broadcasting this parameter.

00 Drive not engaged
 01 Drive is engaged
 10 Error
 11 Not available

Data Length: 2 bits
 Resolution: 4 states/2 bit, 0 offset
 Data Range: 0 to 3 Operational Range: same as data range
 Type: Status
 Supporting information:
 PGN 64932

SPN 3464 Engine Throttle Actuator 1 Control Command

The control command to throttle actuator 1, normalized to percent, where 0% represents fully closed and 100% represents fully open. Typically, this throttle actuator is used to regulate air or air / fuel mix to the engine. Using the standard convention for determining the position. Left/front is #1 and right/rear is #2 (SPN 3465).

Data Length: 2 bytes
 Resolution: 0.0025 %/bit, 0 offset
 Data Range: 0 to 160.6375 % Operational Range: 0 to 100%
 Type: Status
 Supporting information:
 PGN 61466

SPN 3465 Engine Throttle Actuator 2 Control Command

The control command to throttle actuator 2, normalized to percent, where 0% represents fully closed and 100% represents fully open. Typically, this throttle actuator is used to regulate air or air / fuel mix to the engine. Using the standard convention for determining the position. Left/front is #1 (SPN 3464) and right/rear is #2.

Data Length: 2 bytes
 Resolution: 0.0025 %/bit, 0 offset
 Data Range: 0 to 160.6375 % Operational Range: 0 to 100%
 Type: Status
 Supporting information:
 PGN 61466

SPN 3466 Engine Fuel Valve 2 Inlet Absolute Pressure

Absolute pressure of gas on inlet side of the second fuel system control valve, using standard convention for determining position. Left/front is #1 (SPN 1390) and right/rear is #2.

Data Length: 2 bytes
 Resolution: 0.1 kPa/bit, 0 offset
 Data Range: 0 to 6,425.5 kPa Operational Range: same as data range
 Type: Measured
 Supporting information:
 PGN 64930

SPN 3467 Engine Gas 2 Mass Flow Rate

Gas mass flow rate delivered to an engine through its second fuel control system, using standard convention for determining position. Left/front is #1 (SPN 1241) and right/rear is #2.

Data Length: 2 bytes
Resolution: 0.05 kg/h per bit, 0 offset
Data Range: 0 to 3212.75 kg/h Operational Range: same as data range
Type: Measured
Supporting information:
PGN 64930

SPN 3468 Engine Fuel Temperature 2

Temperature 2 of fuel (or gas). See SPN 174 for fuel temperature 1.

Data Length: 1 byte
Resolution: 1 deg C/bit, -40 deg C offset
Data Range: -40 to 210 deg C Operational Range: same as data range
Type: Measured
Supporting information:
PGN 64930

SPN 3469 Engine Fuel Valve 2 Outlet Absolute Pressure

Absolute pressure of gas on outlet side of the second fuel system control valve. See SPN 2980 for the first or only fuel system control valve.

Data Length: 2 bytes
Resolution: 0.1 kPa/bit, 0 offset
Data Range: 0 to 6,425.5 kPa Operational Range: same as data range
Type: Measured
Supporting information:
PGN 64930

SPN 3470 Engine Turbocharger Compressor Control

The control command to a compressor bypass actuator, normalized to percent, where 0% nominally represents fully closed and 100% represents fully open. Typically, the turbocharger compressor bypass actuator is used to keep the engine out of surge by metering compressed air (charge).

Data Length: 2 bytes
Resolution: 0.0025 %/bit, 0 offset
Data Range: 0 to 160.6375 % Operational Range: 0 to 100%
Type: Status
Supporting information:
PGN 64931

SPN 3479 *Aftertreatment 1 Fuel Pressure Control*

Position that the controller is commanding the aftertreatment 1 fuel pressure control to maintain. 0% = fully closed, 100% = fully open.

Data Length: 2 bytes
Resolution: 0.0025 %/bit, 0 offset
Data Range: 0 to 160.6375 % Operational Range: same as data range
Type: Status
Supporting information:
PGN 64929

SPN 3480 *Aftertreatment 1 Fuel Pressure 1*

First fuel pressure measurement for the aftertreatment 1 system

Data Length: 2 bytes
Resolution: 0.1 kPa/bit, 0 offset
Data Range: 0 to 6,425.5 kPa Operational Range: same as data range
Type: Measured
Supporting information:
PGN 64929

SPN 3481 *Aftertreatment 1 Fuel Rate*

Rate of fuel being delivered to aftertreatment 1 for regeneration

Data Length: 2 bytes
Resolution: 0.05 L/h per bit, 0 offset
Data Range: 0 to 3,212.75 L/h Operational Range: same as data range
Type: Measured
Supporting information:
PGN 64929

SPN 3482 *Aftertreatment 1 Fuel Enable Actuator*

Indicates whether aftertreatment 1 fuel enable actuator is on or off

00 not active
01 active
10 reserved for SAE assignment
11 not available

Data Length: 2 bits
Resolution: 4 states/2 bit, 0 offset
Data Range: 0 to 3 Operational Range: same as data range
Type: Status
Supporting information:
PGN 64929

SPN 3483 *Aftertreatment 1 Regeneration Status*

Indicates whether regeneration is active or inactive in aftertreatment 1.

00 not active
 01 active
 10 reserved for SAE assignment
 11 not available

Data Length: 2 bits
 Resolution: 4 states/2 bit, 0 offset
 Data Range: 0 to 3 Operational Range: same as data range
 Type: Status
 Supporting information:
 PGN 64929

SPN 3484 *Aftertreatment 1 Ignition*

Indicates whether aftertreatment 1 ignition circuit is energized by the ECM.

00 not active
 01 active
 10 reserved for SAE assignment
 11 not available

Data Length: 2 bits
 Resolution: 4 states/2 bit, 0 offset
 Data Range: 0 to 3 Operational Range: same as data range
 Type: Status
 Supporting information:
 PGN 64929

SPN 3485 *Aftertreatment 1 Supply Air Pressure*

Pressure of the supply air for aftertreatment 1. Supply air is the air supplied from a pneumatic line for an air-assisted or pneumatic actuator. One example is an air assisted fuel injector (the supply air assists in the atomization of fuel).

Data Length: 2 bytes
 Resolution: 0.1 kPa/bit, 0 offset
 Data Range: 0 to 6,425.5 kPa Operational Range: same as data range
 Type: Measured
 Supporting information:
 PGN 64927

SPN 3486 *Aftertreatment 1 Purge Air Pressure*

Pressure of the purge air supply for aftertreatment 1

Data Length: 2 bytes
 Resolution: 0.1 kPa/bit, 0 offset
 Data Range: 0 to 6,425.5 kPa Operational Range: same as data range
 Type: Measured
 Supporting information:
 PGN 64927

SPN 3487 *Aftertreatment 1 Air Pressure Control*

Position that the controller is commanding the aftertreatment 1 air pressure control to maintain. 0% = fully closed, 100% = fully open

Data Length: 2 bytes
Resolution: 0.0025 %/bit, 0 offset
Data Range: 0 to 160.6375 % Operational Range: same as data range
Type: Measured
Supporting information:
PGN 64927

SPN 3488 *Aftertreatment 1 Air Pressure Actuator Position*

Position of the aftertreatment 1 air pressure actuator as measured by a position feedback sensor.

Data Length: 1 byte
Resolution: 0.4 %/bit, 0 offset
Data Range: 0 to 100 % Operational Range: same as data range
Type: Measured
Supporting information:
PGN 64927

SPN 3489 *Aftertreatment 1 Air Enable Actuator*

Indicates whether aftertreatment 1 air enable actuator is on or off

00 not active
01 active
10 reserved for SAE assignment
11 not available

Data Length: 2 bits
Resolution: 4 states/2 bit, 0 offset
Data Range: 0 to 3 Operational Range: same as data range
Type: Status
Supporting information:
PGN 64927

SPN 3490 *Aftertreatment 1 Purge Air Actuator*

Indicates whether aftertreatment 1 purge air actuator is on or off

00 not active
01 active
10 reserved for SAE assignment
11 not available

Data Length: 2 bits
Resolution: 4 states/2 bit, 0 offset
Data Range: 0 to 3 Operational Range: same as data range
Type: Status
Supporting information:
PGN 64927

SPN 3491 *Aftertreatment 1 Atomization Air Actuator*

Indicates whether aftertreatment 1 atomization air actuator is on or off

00 not active
 01 active
 10 reserved for SAE assignment
 11 not available

Data Length: 2 bits
 Resolution: 4 states/2 bit, 0 offset
 Data Range: 0 to 3 Operational Range: same as data range
 Type: Status
 Supporting information:
 PGN 64927

SPN 3492 *Aftertreatment 1 Air System Relay*

Indicates whether aftertreatment 1 air system relay is on or off

00 not active
 01 active
 10 reserved for SAE assignment
 11 not available

Data Length: 2 bits
 Resolution: 4 states/2 bit, 0 offset
 Data Range: 0 to 3 Operational Range: same as data range
 Type: Status
 Supporting information:
 PGN 64927

SPN 3493 *Aftertreatment 2 Fuel Pressure Control*

Position that the controller is commanding the aftertreatment 2 fuel pressure control to maintain. 0% = fully closed, 100% = fully open.

Data Length: 2 bytes
 Resolution: 0.0025 %/bit, 0 offset
 Data Range: 0 to 160.6375 % Operational Range: same as data range
 Type: Status
 Supporting information:
 PGN 64928

SPN 3494 *Aftertreatment 2 Fuel Pressure 1*

Pressure of the fuel for Aftertreatment 2.

Data Length: 2 bytes
 Resolution: 0.1 kPa/bit, 0 offset
 Data Range: 0 to 6,425.5 kPa Operational Range: same as data range
 Type: Measured
 Supporting information:
 PGN 64928

SPN 3495 *Aftertreatment 2 Fuel Rate*

Rate of fuel being delivered to aftertreatment 2 for regeneration

Data Length: 2 bytes

Resolution: 0.05 L/h per bit, 0 offset

Data Range: 0 to 3,212.75 L/h Operational Range: same as data range

Type: Measured

Supporting information:

PGN 64928

SPN 3496 *Aftertreatment 2 Fuel Enable Actuator*

Indicates whether aftertreatment 2 fuel enable actuator is on or off

00 not active

01 active

10 reserved for SAE assignment

11 not available

Data Length: 2 bits

Resolution: 4 states/2 bit, 0 offset

Data Range: 0 to 3 Operational Range: same as data range

Type: Status

Supporting information:

PGN 64928

SPN 3497 *Aftertreatment 2 Regeneration Status*

Indicates whether regeneration is active or inactive in aftertreatment 2.

00 not active

01 active

10 reserved for SAE assignment

11 not available

Data Length: 2 bits

Resolution: 4 states/2 bit, 0 offset

Data Range: 0 to 3 Operational Range: same as data range

Type: Status

Supporting information:

PGN 64928

SPN 3498 Aftertreatment 2 Ignition

Indicates whether aftertreatment 2 ignition circuit is energized by the ECM.

00 not active
 01 active
 10 reserved for SAE assignment
 11 not available

Data Length: 2 bits
 Resolution: 4 states/2 bit, 0 offset
 Data Range: 0 to 3 Operational Range: same as data range
 Type: Status
 Supporting information:
 PGN 64928

SPN 3499 Aftertreatment 2 Supply Air Pressure

Pressure of the supply air for aftertreatment 2. Supply air is the air supplied from a pneumatic line for an air-assisted or pneumatic actuator. One example is an air assisted fuel injector (the supply air assists in the atomization of fuel).

Data Length: 2 bytes
 Resolution: 0.1 kPa/bit, 0 offset
 Data Range: 0 to 6,425.5 kPa Operational Range: same as data range
 Type: Measured
 Supporting information:
 PGN 64926

SPN 3500 Aftertreatment 2 Purge Air Pressure

Pressure of the purge air supply for aftertreatment 2

Data Length: 2 bytes
 Resolution: 0.1 kPa/bit, 0 offset
 Data Range: 0 to 6,425.5 kPa Operational Range: same as data range
 Type: Measured
 Supporting information:
 PGN 64926

SPN 3501 Aftertreatment 2 Air Pressure Control

Position that the controller is commanding the aftertreatment 2 air pressure control to maintain. 0% = fully closed, 100% = fully open

Data Length: 2 bytes
 Resolution: 0.0025 %/bit, 0 offset
 Data Range: 0 to 160.6375 % Operational Range: same as data range
 Type: Measured
 Supporting information:
 PGN 64926

SPN 3502 *Aftertreatment 2 Air Pressure Actuator Position*

Position of the aftertreatment 2 air pressure actuator as measured by a position feedback sensor.

Data Length: 1 byte

Resolution: 0.4 %/bit, 0 offset

Data Range: 0 to 100 % Operational Range: same as data range

Type: Measured

Supporting information:

PGN 64926

SPN 3503 *Aftertreatment 2 Air Enable Actuator*

Indicates whether aftertreatment 2 air enable actuator is on or off

00 not active

01 active

10 reserved for SAE assignment

11 not available

Data Length: 2 bits

Resolution: 4 states/2 bit, 0 offset

Data Range: 0 to 3 Operational Range: same as data range

Type: Status

Supporting information:

PGN 64926

SPN 3504 *Aftertreatment 2 Purge Air Actuator*

Indicates whether aftertreatment 2 purge air actuator is on or off

00 not active

01 active

10 reserved for SAE assignment

11 not available

Data Length: 2 bits

Resolution: 4 states/2 bit, 0 offset

Data Range: 0 to 3 Operational Range: same as data range

Type: Status

Supporting information:

PGN 64926

SPN 3505 *Aftertreatment 2 Atomization Air Actuator*

Indicates whether aftertreatment 2 atomization air actuator is on or off

00 not active
01 active
10 reserved for SAE assignment
11 not available

Data Length: 2 bits
Resolution: 4 states/2 bit, 0 offset
Data Range: 0 to 3 Operational Range: same as data range
Type: Status
Supporting information:
PGN 64926

SPN 3506 *Aftertreatment 2 Air System Relay*

Indicates whether aftertreatment 2 air system relay is on or off

00 not active
01 active
10 reserved for SAE assignment
11 not available

Data Length: 2 bits
Resolution: 4 states/2 bit, 0 offset
Data Range: 0 to 3 Operational Range: same as data range
Type: Status
Supporting information:
PGN 64926

SPN 3509 *Sensor supply voltage 1*

Sensor ECU supply voltage 1

Data Length: 2 bytes
Resolution: 0.05 V/bit, 0 offset
Data Range: 0 to 3212.75 V Operational Range: same as data range
Type: Measured
Supporting information:
PGN 64925

SPN 3510 *Sensor supply voltage 2*

Sensor ECU supply voltage 2

Data Length: 2 bytes
Resolution: 0.05 V/bit, 0 offset
Data Range: 0 to 3212.75 V Operational Range: same as data range
Type: Measured
Supporting information:
PGN 64925

SPN 3511 Sensor supply voltage 3

Sensor ECU supply voltage 3

Data Length: 2 bytes

Resolution: 0.05 V/bit, 0 offset

Data Range: 0 to 3212.75 V Operational Range: same as data range

Type: Measured

Supporting information:

PGN 64925

SPN 3512 Sensor supply voltage 4

Sensor ECU supply voltage 4

Data Length: 2 bytes

Resolution: 0.05 V/bit, 0 offset

Data Range: 0 to 3212.75 V Operational Range: same as data range

Type: Measured

Supporting information:

PGN 64925

SPN 3513 Sensor supply voltage 5

Sensor ECU supply voltage 5

Data Length: 2 bytes

Resolution: 0.05 V/bit, 0 offset

Data Range: 0 to 3212.75 V Operational Range: same as data range

Type: Measured

Supporting information:

PGN 64924

SPN 3514 Sensor supply voltage 6

Sensor ECU supply voltage 6

Data Length: 2 bytes

Resolution: 0.05 V/bit, 0 offset

Data Range: 0 to 3212.75 V Operational Range: same as data range

Type: Measured

Supporting information:

PGN 64924

SPN 3515 Catalyst Reagent Temperature 2

Temperature of the catalyst reagent at the device measuring reagent quality

Data Length: 1 byte

Resolution: 1 deg C/bit, -40 deg C offset

Data Range: -40 to 210 deg C Operational Range: same as data range

Type: Measured

Supporting information:

PGN 64923

SPN 3516 Catalyst Reagent Concentration

A measure of the concentration of urea in water. Zero percent means that the tank contains no urea. A 32.5% value indicates that the reagent is of the proper concentration. The 32.5% value indicates that the concentration is highest quality.

Data Length: 1 byte

Resolution: 0.25 %/bit, 0 offset

Data Range: 0 to 62.5 % Operational Range: same as data range

Type: Measured

Supporting information:

PGN 64923

SPN 3517 Catalyst Tank Level 2

The measure of the reagent level in the catalyst tank.

Data Length: 2 bytes

Resolution: 0.1 mm/bit, 0 offset

Data Range: 0 to 6,425.5 mm (0 to Operational Range: same as data range

Type: Measured

Supporting information:

PGN 65110

SPN 3518 Catalyst Reagent Conductivity

A measure of the conductivity of the reagent or fluid at the sensor. The conductivity is an indication of the reagent's chemical make up.

Data Length: 1 byte

Resolution: 5 microSiemens/mm, 0 offset

Data Range: 0 to 1250 Operational Range: same as data range

Type: Measured

Supporting information:

PGN 64923

SPN 3519 Catalyst Reagent Temperature 2 Preliminary FMI

Used to identify the applicable J1939-73 FMI that applies to the most significant failure of the catalyst temperature

Data Length: 5 bits
Resolution: Binary, 0 offset
Data Range: 0 to 31 Operational Range: same as data range
Type: Status
Supporting information:
PGN 64923

SPN 3520 Catalyst Reagent Properties Preliminary FMI

Used to identify the applicable J1939-73 FMI that applies to the most significant failure of the catalyst reagent properties sensor. This may be used for indicating failures of the catalyst reagent concentration, catalyst reagent conductivity or catalyst reagent type.

Data Length: 5 bits
Resolution: Binary, 0 offset
Data Range: 0 to 31 Operational Range: same as data range
Type: Status
Supporting information:
PGN 64923

SPN 3521 Catalyst Reagent Type

This parameter indicates what reagent is in the tank.

0000 - Catalyst reagent is urea
0001 - Catalyst reagent is water
0010 - Catalyst reagent is diesel
0011 - Catalyst reagent is proper
0100 to 1100 - Reserved for SAE assignment
1101 - Not able to determine catalyst reagent type (type unknown)
1110 - Error detected with urea reagent type detection
1111 - Not available

Data Length: 4 bits
Resolution: 16 states/4 bit, 0 offset
Data Range: 0 to 15 Operational Range: same as data range
Type: Status
Supporting information:
PGN 64923

SPN 3522 Aftertreatment 1 Total Fuel Used

Total amount of fuel used by aftertreatment device 1 over the lifetime of the device.

Data Length: 4 bytes
Resolution: 0.5 L/bit, 0 offset
Data Range: 0 to 2,105,540,607.5 L Operational Range: same as data range
Type: Measured
Supporting information:
PGN 64920

SPN 3523 *Aftertreatment 1 Total Regeneration Time*

Total amount of time that aftertreatment device 1 has been regenerating over the lifetime of the device.

Data Length: 4 bytes

Resolution: 1 s/bit, 0 offset

Data Range: 0 to 4,211,081,215 s Operational Range: same as data range

Type: Measured

Supporting information:

PGN 64920

SPN 3524 *Aftertreatment 1 Total Disabled Time*

Total amount of time that aftertreatment 1 regeneration has been manually disabled.

Data Length: 4 bytes

Resolution: 1 s/bit, 0 offset

Data Range: 0 to 4,211,081,215 s Operational Range: same as data range

Type: Measured

Supporting information:

PGN 64920

SPN 3525 *Aftertreatment 1 Total Number of Active Regenerations*

Total number of active regenerations by aftertreatment device 1 over the lifetime of the device.

Data Length: 4 bytes

Resolution: 1 count/bit, 0 offset

Data Range: 0 to 4,294,967,295 counts Operational Range: same as data range

Type: Status

Supporting information:

PGN 64920

SPN 3526 *Aftertreatment 2 Total Fuel Used*

Total amount of fuel used by aftertreatment device 2 over the lifetime of the device.

Data Length: 4 bytes

Resolution: 0.5 L/bit, 0 offset

Data Range: 0 to 2,105,540,607.5 L Operational Range: same as data range

Type: Status

Supporting information:

PGN 64921

SPN 3527 *Aftertreatment 2 Total Regeneration Time*

Total amount of time that aftertreatment device 2 has been regenerating over the lifetime of the device.

Data Length: 4 bytes

Resolution: 1 s/bit, 0 offset

Data Range: 0 to 4,211,081,215 s Operational Range: same as data range

Type: Status

Supporting information:

PGN 64921

SPN 3528 *Aftertreatment 2 Total Disabled Time*

Total amount of time that aftertreatment 2 regeneration has been manually disabled.

Data Length: 4 bytes

Resolution: 1 s/bit, 0 offset

Data Range: 0 to 4,211,081,215 s Operational Range: same as data range

Type: Status

Supporting information:

PGN 64921

SPN 3529 *Aftertreatment 2 Total Number of Active Regenerations*

Total number of active regenerations by aftertreatment device 2 over the lifetime of the device.

Data Length: 4 bytes

Resolution: 1 count/bit, 0 offset

Data Range: 0 to 4,294,967,295 counts Operational Range: same as data range

Type: Measured

Supporting information:

PGN 64921

SPN 3532 *Catalyst Tank Level Preliminary FMI*

Used to identify the applicable J1939-73 FMI that applies to the most significant failure of the catalyst tank level sensor. This FMI is applicable to either the catalyst tank level 1 or catalyst tank level 2 parameters.

Data Length: 5 bits

Resolution: Binary, 0 offset

Data Range: 0 to 31 Operational Range: same as data range

Type: Status

Supporting information:

PGN 65110

SPN 3533 Transmission Oil Level Switch

This switch indicates whether transmission oil level is full or empty.

00 - Empty
01 - Full or not empty
10 - Error
11 - Not available

Data Length: 2 bits
Resolution: 4 states/2 bit, 0 offset
Data Range: 0 to 3 Operational Range: same as data range
Type: Status
Supporting information:
PGN 64917

SPN 3543 Engine Operating State

This parameter is used to indicate the current state, or mode, of operation by the engine. This is a status parameter.

Bit state 0000 = Engine Stopped
Bit state 0001 = Pre-Start
Bit state 0010 = Starting
Bit state 0011 = Warm-Up
Bit state 0100 = Running
Bit state 0101 = Cool-down
Bit state 0110 = Engine Stopping
Bit state 0111 = Post-Run
Bit states 1000-1101 = available for SAE assignment
Bit state 1110 = <reserved>
Bit state 1111 = not available

STOPPED - In the stopped state, the ECM is powered and the engine is not turning. The engine is ready to start.

PRE-START - In the PRE-START state, the engine is not running. Actions are taken by various subsystem controls to prepare the engine for cranking and starting. This may include any priming, prelubrication, preheating sequences, interlocks or other start permissives. These subsystems have their own state based control and communicate their status to the engine state control logic.

STARTING - During the STARTING state, actions are taken by various subsystem controls to attempt to start the engine.

WARM-UP - During the WARM-UP state, the engine operates at reduced speed and / or load to allow the engine to come up to operating temperature.

RUNNING - In the RUNNING state, the engine is turning and is prepared to output power.

COOL-DOWN - During the COOLDOWN state, the engine operates at reduced speed and / or load to allow the engine to cool off before the engine is stopped.

STOPPING - In the STOPPING state, actions are taken by various subsystem controls to attempt to stop the engine.

POST-RUN - During the POST-RUN state, the engine is not turning. Actions are taken by various subsystem controls to prevent engine damage and extend component life. The engine is not ready to start.

Data Length: 4 bits
Resolution: 16 states/4 bit, 0 offset
Data Range: 0 to 15 Operational Range: same as data range
Type: Status
Supporting information:
PGN 64914

SPN 3544 **Time Remaining in Engine Operating State**

This parameter is used to indicate the time remaining in the current engine operating state, based on the state defined in the SPN "Engine Operating State" (SPN 3543). For the states in which time remaining is not applicable, use 65535 (\$FFFF).

Data Length: 2 bytes
 Resolution: 1 s/bit, 0 offset
 Data Range: 0 to 64,255 s Operational Range: same as data range
 Type: Status
 Supporting information:
 PGN 64914

SPN 3548 **Engine Waste Oil Reservoir Level**

Level of crankcase blowby emulsion collected by a container. Normalized to percent, 0% represents completely empty and 100% represents completely full.

Data Length: 1 byte
 Resolution: 0.4 %/bit, 0 offset
 Data Range: 0 to 100 % Operational Range: same as data range
 Type: Measured
 Supporting information:
 PGN 65130

SPN 3549 **Engine Oil-Filter Outlet Pressure**

Oil pressure (gauge) measured just downstream of oil filter. Used in conjunction with SPN1208 (pre-filter oil pressure) to determine oil filter health.

Data Length: 1 byte
 Resolution: 4 kPa/bit, 0 offset
 Data Range: 0 to 1000 kPa Operational Range: same as data range
 Type: Measured
 Supporting information:
 PGN 65130

SPN 3550 **Engine Oil Priming Pump Switch**

Switch input for activating the engine oil priming pump.

00 = Off
 01 = On
 10 = Error
 11 = Not available or not installed

Data Length: 2 bits
 Resolution: 4 states/2 bit, 0 offset
 Data Range: 0 to 3 Operational Range: same as data range
 Type: Measured
 Supporting information:
 PGN 65130

SPN 3551 Engine Oil Priming State

Determination of whether or not the engine is (or has recently been) sufficiently lubricated for starting purposes.

00 = Not sufficiently lubricated
01 = Sufficiently lubricated
10 = Unable to determine if sufficiently lubricated
11 = Not available or not installed

Data Length: 2 bits
Resolution: 4 states/2 bit, 0 offset
Data Range: 0 to 3 Operational Range: same as data range
Type: Status
Supporting information:
PGN 65130

SPN 3552 Engine Oil Pre-Heated State

Indicates whether the engine oil pre-heated sufficiently for starting purposes.

00 = Not sufficiently pre-heated
01 = Sufficiently pre-heated
10 = Unable to determine if engine oil is pre-heated sufficiently
11 = Not available or not installed

Data Length: 2 bits
Resolution: 4 states/2 bit, 0 offset
Data Range: 0 to 3 Operational Range: same as data range
Type: Status
Supporting information:
PGN 65130

SPN 3553 Engine Coolant Pre-heated State

Indicates whether the engine coolant is pre-heated sufficiently for starting purposes.

00 = Not sufficiently pre-heated
01 = Sufficiently pre-heated
10 = Unable to determine engine coolant pre-heated sufficiently
11 = Not available or not installed

Data Length: 2 bits
Resolution: 4 states/2 bit, 0 offset
Data Range: 0 to 3 Operational Range: same as data range
Type: Status
Supporting information:
PGN 65130

SPN 3554 Engine Ventilation Status

Engine ventilation control states.

000 = Sufficiently vented (all combustible gases have been evacuated from intake and exhaust systems)
 001 = Ventilation needed (combustible gases may be present in intake and exhaust systems)
 010 = Ventilation delay (delay without cranking between ventilation and start engine states)
 011 = Currently venting (engine cranks w/o gas or ignition to clear intake and exhaust systems with air)
 100 = Reserved for SAE assignment
 101 = Reserved for SAE assignment
 110 = Not able to determine if sufficiently vented
 111 = Not available or not installed

Data Length: 3 bits
 Resolution: 8 states/3 bit, 0 offset
 Data Range: 0 to 7 Operational Range: same as data range
 Type: Status
 Supporting information:
 PGN 65130

SPN 3557 Parking Brake Red Warning Signal

This parameter commands the Parking Brake red optical warning signal.

00 – off
 01 – on
 10 – Reserved
 11 – Take no action

Data Length: 2 bits
 Resolution: 4 states/2 bit, 0 offset
 Data Range: 0 to 3 Operational Range: same as data range
 Type: Status
 Supporting information:
 PGN 65274

SPN 3558 AETC Data Collection Standard

Indicates the standardized method by which torque data was obtained for the Advertised Engine Torque Curve (AETC). For example, in North America, heavy duty diesel engine specifications are typically based on SAE J1995. Other applicable SAE, ISO, or DIN standards may be added as necessary in the future.

0000 SAE J1995
 0001-1101 Not Defined
 1111 Not Available

Data Length: 4 bits
 Resolution: 16 states/4 bit, 0 offset
 Data Range: 0 to 15 Operational Range: same as data range
 Type: Status
 Supporting information:
 PGN 64912

SPN 3559 *Number of AETC data points*

Indicates the number of speed / torque data points contained in the Advertised Engine Torque Curve broadcast (AETC). A minimum of 5 points is required, with a maximum of 15 points available as needed to accurately convey the curve.

Data Length: 4 bits
Resolution: 16 states/4 bit, 0 offset
Data Range: 0 to 15 Operational Range: 5 to 15 points
Type: Measured
Supporting information: See Appendix D - PGN 64912
PGN 64912

SPN 3560 *AETC Speed Value*

Engine speed value of the data points in PGN 64912 – Advertised Engine Torque Curve (AETC).

Data Length: 2 bytes
Resolution: 0.125 rpm/bit, 0 offset
Data Range: 0 to 8,031.875 rpm Operational Range: same as data range
Type: Measured
Supporting information: See Appendix D - PGN 64912
PGN 64912

SPN 3561 *AETC Torque value*

Engine torque value of the data points in PGN 64912 – Advertised Engine Torque Curve (AETC).

Data Length: 2 bytes
Resolution: 1 Nm/bit, 0 offset
Data Range: 0 to 64,255 Nm Operational Range: same as data range
Type: Measured
Supporting information: See Appendix D - PGN 64912
PGN 64912

SPN 3562 *Engine Intake Manifold #2 Pressure*

The gage pressure measurement of the air intake manifold for bank #2 or the second air intake manifold. If there are multiple air pressure sensors in the second intake stream, this is the last one in flow direction before entering the combustion chamber. See also SPNs 1127-1130 and SPN 102 for alternate range and resolution.

Data Length: 1 byte
Resolution: 2 kPa/bit, 0 offset
Data Range: 0 to 500 kPa Operational Range: same as data range
Type: Measured
Supporting information:
PGN 64976

SPN 3563 Engine Intake Manifold #1 Absolute Pressure

The absolute pressure measurement of the air intake manifold. If there are multiple air pressure sensors in the intake stream, this is the last one in flow direction before entering the combustion chamber.

Data Length: 1 byte
Resolution: 2 kPa/bit, 0 offset
Data Range: 0 to 500 kPa Operational Range: same as data range
Type: Measured
Supporting information:
PGN 64976

SPN 3564 Lane Departure Warning Enable Command

Command to enable/disable Lane Departure Indication

00 Disable Lane Departure Warning
01 Enable Lane Departure Warning
10 Reserved
11 Don't care

Data Length: 2 bits
Resolution: 4 states/2 bit, 0 offset
Data Range: 0 to 3 Operational Range: same as data range
Type: Status
Supporting information:
PGN 43264

SPN 3565 Lane Departure Left

Indicates that the middle of vehicle departs the lane on the left side. The parameter indicates that the vehicle is changing the lane to the left.

00 Middle of the vehicle does not depart the lane to the left side
01 Middle of the vehicle departs the lane to the left side
10 Reserved
11 Take no action

Data Length: 2 bits
Resolution: 4 states/2 bit, 0 offset
Data Range: 0 to 3 Operational Range: same as data range
Type: Status
Supporting information:
PGN 61447

SPN 3566 Lane Departure Right

Indicates that the middle of vehicle departs the lane on the right side. The parameter indicates that the vehicle is changing the lane to the right.

00 Middle of the vehicle does not depart the lane to the right side
 01 Middle of the vehicle departs the lane to the right side
 10 Reserved
 11 Take no action

Data Length: 2 bits
 Resolution: 4 states/2 bit, 0 offset
 Data Range: 0 to 3 Operational Range: same as data range
 Type: Status
 Supporting information:
 PGN 61447

SPN 3589 Engine Oil Priming Pump Control

This control is used to activate a pump that lubricates the engine, particularly prior to initial engine startup.

00 = Off
 01 = On
 10 = Reserved
 11 = unavailable

Data Length: 2 bits
 Resolution: 4 states/2 bit, 0 offset
 Data Range: 0 to 3 Operational Range: same as data range
 Type: Status
 Supporting information:
 PGN 64914

SPN 3597 ECU Power Output Supply Voltage #1

The first power output from an ECM

Data Length: 2 bytes
 Resolution: 0.05 V/bit, 0 offset
 Data Range: 0 to 3212.75 V Operational Range: same as data range
 Type: Measured
 Supporting information:
 PGN 65165

SPN 3598 ECU Power Output Supply Voltage #2

The second power output from an ECM.

Data Length: 2 bytes
 Resolution: 0.05 V/bit, 0 offset
 Data Range: 0 to 3212.75 V Operational Range: same as data range
 Type: Measured
 Supporting information:
 PGN 65165

SPN 3599 ECU Power Output Supply Voltage #3

The third power output from an ECM.

Data Length: 2 bytes

Resolution: 0.05 V/bit, 0 offset

Data Range: 0 to 3212.75 V Operational Range: same as data range

Type: Measured

Supporting information:

PGN 65165

SPN 3600 Steering Straight Ahead Position Reset

Used to reset the straight ahead position for a steering sensor in the steering column or a steering controller's straight ahead position on any steerable axle.

00 Take no action - Do not Reset

01 Reset

10 Reserved, take no action

11 Not applicable

Data Length: 2 bits

Resolution: 4 states/2 bit, 0 offset

Data Range: 0 to 3 Operational Range: same as data range

Type: Status

Supporting information:

PGN 56832

SPN 3601 Engine Fuel Shutoff Valve Leak Test Control

Control setting for fuel shutoff valve proving system test. Typically, this type of system can only be used with a dual fuel shutoff system. The test consists of a small pump to pressurize the chamber between the dual fuel shutoffs when they are closed. After pressurizing, the test is passed if the pressure is above a certain threshold, indicating the fuel shutoffs are sealed completely shut without leaks. Otherwise, a low pressure indicates a leak is present past one or both of the fuel shutoffs.

00 = Off (reset / no test in process)

01 = On (test in process / test complete)

10 = Reserved

11 = Don't care / take no action

In addition to communicating desired action of the fuel shutoff valve proving system test and its driver status, this new SPN can be used to communicate whether the fuel shutoff valve proving system test failed, through the use of FMIs.

Data Length: 2 bits

Resolution: 4 states/2 bit, 0 offset

Data Range: 0 to 3 Operational Range: same as data range

Type: Status

Supporting information:

PGN 64914

SPN 3602 Engine Oil Pre-heater Control

Control setting for an electrically actuated oil pre-heating device.

00 = Off
01 = On
10 = Reserved
11 = Don't care / take no action

In addition to communicating desired action of the electrically actuated oil pre-heater and its driver status, this new SPN can be used to communicate if any attempts to adequately pre-heat the oil are unsuccessful, through the use of FMIs.

Data Length: 2 bits
Resolution: 4 states/2 bit, 0 offset
Data Range: 0 to 3 Operational Range: same as data range
Type: Status
Supporting information:
PGN 64914

SPN 3603 Engine Electrical System Power Conservation Control

Control setting for cutting power to various devices when the engine is not in use. Useful if it is desired to keep the engine in standby, with main control ECM still powered on and communicating with outside world, but actuators and certain other ECMs can be de-powered.

00 - Off (No Power conservation; all systems with supply power available)
01 - On (power conservation active; certain systems have supply power withheld)
10 - Reserved
11 - Unavailable

Data Length: 2 bits
Resolution: 4 states/2 bit, 0 offset
Data Range: 0 to 3 Operational Range: same as data range
Type: Status
Supporting information:
PGN 64914

SPN 3604 Engine Block / Coolant Pre-heater Control

Control setting for an electrically actuated engine block or coolant pre-heating device.

00 - Off
01 - On
10 - Reserved
11 - Unavailable

Data Length: 2 bits
Resolution: 4 states/2 bit, 0 offset
Data Range: 0 to 3 Operational Range: same as data range
Type: Status
Supporting information:
PGN 64914

SPN 3605 Engine Coolant Circulating Pump Control

Control setting for an electrically actuated engine coolant circulating pump.

00 = Off
01 = On
10 = Reserved
11 = Don't care / take no action

Data Length: 2 bits
Resolution: 4 states/2 bit, 0 offset
Data Range: 0 to 3 Operational Range: same as data range
Type: Status
Supporting information:
PGN 64914

SPN 3606 Engine Controlled Shutdown Request

A signal issued by the engine control system to a user or external system requesting for a controlled shutdown. This request is made when engine protection diagnostics determine a condition warrants a shutdown soon, but it is not severe enough to necessitate an immediate shutdown. This function gives notice such that the engine can be unloaded and cooled down before stopping.

00 = Off (No Shutdown Requested)
01 = On (Shutdown Requested)
10 = Reserved
11 = Don't care / take no action

Data Length: 2 bits
Resolution: 4 states/2 bit, 0 offset
Data Range: 0 to 3 Operational Range: same as data range
Type: Status
Supporting information:
PGN 64914

SPN 3607 Engine Emergency (Immediate) Shutdown Indication

A signal issued by the engine control system to a user or external system indicating that it is immediately shutting the engine down. This indication is made when engine protection diagnostics determine a condition necessitates an immediate shutdown. This function gives notice that this has occurred.

00 = Off (No Shutdown Requested)
01 = On (Shutdown Requested)
10 = Reserved
11 = Don't care / take no action

Data Length: 2 bits
Resolution: 4 states/2 bit, 0 offset
Data Range: 0 to 3 Operational Range: same as data range
Type: Status
Supporting information:
PGN 64914

SPN 3608 Engine Fuel Shutoff Vent Control

Control setting for a fuel shutoff vent. Typically, for a dual fuel shutoff system, the vent line is located between them and is plumbed to vent outside to atmosphere. The vent control typically always actuates opposite to that of the fuel shutoff(s) control. Thus, when the fuel shutoff(s) are closed, the vent is open, thereby 'ventilating' any leftover or leaking gas from the fuel shutoff. When the fuel shutoff(s) are open, the vent is closed, thereby all gas passes through to the engine.

00 = Closed (vent closed)

01 = Open (vent open)

10 = Reserved

11 = Don't care / take no action

Data Length: 2 bits

Resolution: 4 states/2 bit, 0 offset

Data Range: 0 to 3 Operational Range: same as data range

Type: Status

Supporting information:

PGN 64914

SPN 3609 (R) Diesel Particulate Filter Intake Pressure 1

This parameter indicates the diesel particulate filter intake gage pressure 1 (bank 1).

Data Length: 2 bytes

Resolution: 0.1 kPa/bit, 0 offset

Data Range: 0 to 6,425.5 kPa Operational Range: same as data range

Type: Measured

Supporting information:

PGN 64908

SPN 3610 (R) Diesel Particulate Filter Outlet Pressure 1

This parameter indicates the diesel particulate filter outlet gage pressure 1 (bank 1).

Data Length: 2 bytes

Resolution: 0.1 kPa/bit, 0 offset

Data Range: 0 to 6,425.5 kPa Operational Range: same as data range

Type: Measured

Supporting information:

PGN 64908

SPN 3611 (R) Diesel Particulate Filter Intake Pressure 2

This parameter indicates the diesel particulate filter intake gage pressure 2 (bank 2).

Data Length: 2 bytes

Resolution: 0.1 kPa/bit, 0 offset

Data Range: 0 to 6,425.5 kPa Operational Range: same as data range

Type: Measured

Supporting information:

PGN 64907

SPN 3612 (R) Diesel Particulate Filter Outlet Pressure 2

This parameter indicates the diesel particulate filter outlet gage pressure 2 (bank 2).

Data Length: 2 bytes
 Resolution: 0.1 kPa/bit, 0 offset
 Data Range: 0 to 6,425.5 kPa Operational Range: same as data range
 Type: Measured
 Supporting information:
 PGN 64907

SPN 3613 Text Display Instructions

This parameter describes the status for the display how to show the information.

0000 Clear display - The displayed information should be deleted or not displayed any more.
 0001 Hold display - The presently displayed information should be retained
 0010 Append at end of display - The transmitted information should be displayed at the end of the presently displayed information
 0011 Overwrite display - The presently displayed information is to be overwritten with the transmitted information
 0100 Overwrite substring - A portion of the presently displayed information is to be overwritten with the transmitted information starting at display text index (SPN 3614)
 0101-1110 Reserved
 1111 - Not applicable

Data Length: 4 bits
 Resolution: 16 states/4 bit, 0 offset
 Data Range: 0 to 15 Operational Range: same as data range
 Type: Status
 Supporting information:
 PGN 43008

SPN 3614 Text Display Index

Used for overwriting consecutive bytes of a displayed string when byte 1 "Text Display Instructions" state is set for "overwrite substring" mode. When used, this byte declares where in the text string that the new text will start overwriting, this number is also known as the start byte. As usual for the transmitted text string, the Text Display Characters will be sent and then terminated by the null character, this will be the stop byte indicator to declare when to stop overwriting.

EXAMPLE: To only modify 3 bytes (50, 51, 52) of an 87 byte character string.

Text Display Instructions - set to 0100b (Overwrite substring)
 Text Display Index - set to 50d (starting byte of desired overwrite)
 Text Display Characters - 3 characters sent, then the null ending byte

Data Length: 1 byte
 Resolution: 1 count/bit, 0 offset
 Data Range: 0 to 250 Operational Range: 0 to 200
 Type: Status
 Supporting information:
 PGN 43008

SPN 3615 Text Display Character

From 1 up to 200 characters to be presented on a display. Up to 4 characters can be displayed without using Transport Protocol. The Display Text characters will follow the standard J1939-71 display method. Control characters can be used but not displayed. The characters are to be terminated with a 00h which is the "null" or "/0" character.

EXAMPLE: Since this parameter starts in byte position 4, the first displayed byte would be in byte 4 of the Data Frame, the fourth displayed byte would be in byte 7 of the Data Frame, byte 8 would be the null character.

Data Length: Variable - up to 200 characters
 Resolution: ASCII, 0 offset
 Data Range: 0 to 255 per byte Operational Range: same as data range
 Type: Status
 Supporting information:
 PGN 43008

SPN 3619 Number of J2012 DTCs

The number J2012 DTCs being conveyed in PGN 64906. If the value of this parameter is zero, the device broadcasting PGN 64906 has no active or previously active J2012 DTCs.

Data Length: 1 byte
 Resolution: 1 count/bit, 0 offset
 Data Range: 0 to 250 Operational Range: same as data range
 Type: Measured
 Supporting information:
 PGN 64906

SPN 3620 J2012 DTC

Five character ASCII SAE J2012 DTC, sent most significant byte first.

Data Length: 5 bytes
 Resolution: ASCII, 0 offset
 Data Range: 0 to 255 per byte Operational Range: same as data range
 Type: Measured
 Supporting information:
 PGN 64906

SPN 3621 J2012 DTC Status

Indicates if the respective SAE J2012 DTC is active or previously active.

0 - DTC is previously active
 1 - DTC is active

Data Length: 1 bit
 Resolution: 2 states/1 bit, 0 offset
 Data Range: 0 to 1 Operational Range: same as data range
 Type: Measured
 Supporting information:
 PGN 64906

SPN 3622 J2012 DTC Occurrence Count

Number of occurrences of the respective SAE J2012 DTC being conveyed.
If more than 126 occurrences happen the value shall be set to 126.
If the occurrence count is not available to be sent then this value shall be set to 127.

Data Length: 7 bits
Resolution: 1 count/bit, 0 offset
Data Range: 0 to 127 Operational Range: 0 to 126
Type: Measured
Supporting information:
PGN 64906

SPN 3623 Vehicle Roll

This parameter indicates the roll in degrees from level. Facing the direction of travel a tip to the left would be indicated by a negative number and a tip to the right would be indicated by a positive number.

Data Length: 2 bytes
Resolution: 1/128 deg/bit, -200 deg offset
Data Range: -200 to 301.99 deg Operational Range: -90 to 90 degrees
Type: Measured
Supporting information:
PGN 64905

SPN 3624 Engine Intake Valve Actuation Oil Pressure for Cylinder #1

The gage pressure of the oil in the hydraulic accumulator that powers the engine intake valve for cylinder #1.

This intake valve pressure is at the first cylinder in the engine, while SPN 2948 reflects the intake valve pressure of the entire engine system.

Data Length: 2 bytes
Resolution: 0.1 kPa/bit, 0 offset
Data Range: 0 to 6,425.5 kPa Operational Range: same as data range
Type: Measured
Supporting information:
PGN 64904

SPN 3625 Engine Intake Valve Actuation Oil Pressure for Cylinder #2

The gage pressure of the oil in the hydraulic accumulator that powers the engine intake valve for cylinder #2.

Data Length: 2 bytes
Resolution: 0.1 kPa/bit, 0 offset
Data Range: 0 to 6,425.5 kPa Operational Range: same as data range
Type: Measured
Supporting information:
PGN 64904

SPN 3626 Engine Intake Valve Actuation Oil Pressure for Cylinder #3

The gage pressure of the oil in the hydraulic accumulator that powers the engine intake valve for cylinder #3.

Data Length: 2 bytes

Resolution: 0.1 kPa/bit, 0 offset

Data Range: 0 to 6,425.5 kPa Operational Range: same as data range

Type: Measured

Supporting information:

PGN 64904

SPN 3627 Engine Intake Valve Actuation Oil Pressure for Cylinder #4

The gage pressure of the oil in the hydraulic accumulator that powers the engine intake valve for cylinder #4.

Data Length: 2 bytes

Resolution: 0.1 kPa/bit, 0 offset

Data Range: 0 to 6,425.5 kPa Operational Range: same as data range

Type: Measured

Supporting information:

PGN 64904

SPN 3628 Engine Intake Valve Actuation Oil Pressure for Cylinder #5

The gage pressure of the oil in the hydraulic accumulator that powers the engine intake valve for cylinder #5.

Data Length: 2 bytes

Resolution: 0.1 kPa/bit, 0 offset

Data Range: 0 to 6,425.5 kPa Operational Range: same as data range

Type: Measured

Supporting information:

PGN 64903

SPN 3629 Engine Intake Valve Actuation Oil Pressure for Cylinder #6

The gage pressure of the oil in the hydraulic accumulator that powers the engine intake valve for cylinder #6.

Data Length: 2 bytes

Resolution: 0.1 kPa/bit, 0 offset

Data Range: 0 to 6,425.5 kPa Operational Range: same as data range

Type: Measured

Supporting information:

PGN 64903

SPN 3630 Engine Intake Valve Actuation Oil Pressure for Cylinder #7

The gage pressure of the oil in the hydraulic accumulator that powers the engine intake valve for cylinder #7.

Data Length: 2 bytes

Resolution: 0.1 kPa/bit, 0 offset

Data Range: 0 to 6,425.5 kPa Operational Range: same as data range

Type: Measured

Supporting information:

PGN 64903

SPN 3631 Engine Intake Valve Actuation Oil Pressure for Cylinder #8

The gage pressure of the oil in the hydraulic accumulator that powers the engine intake valve for cylinder #8.

Data Length: 2 bytes

Resolution: 0.1 kPa/bit, 0 offset

Data Range: 0 to 6,425.5 kPa Operational Range: same as data range

Type: Measured

Supporting information:

PGN 64903

SPN 3632 Engine Intake Valve Actuation Oil Pressure for Cylinder #9

The gage pressure of the oil in the hydraulic accumulator that powers the engine intake valve for cylinder #9.

Data Length: 2 bytes

Resolution: 0.1 kPa/bit, 0 offset

Data Range: 0 to 6,425.5 kPa Operational Range: same as data range

Type: Measured

Supporting information:

PGN 64902

SPN 3633 Engine Intake Valve Actuation Oil Pressure for Cylinder #10

The gage pressure of the oil in the hydraulic accumulator that powers the engine intake valve for cylinder #10.

Data Length: 2 bytes

Resolution: 0.1 kPa/bit, 0 offset

Data Range: 0 to 6,425.5 kPa Operational Range: same as data range

Type: Measured

Supporting information:

PGN 64902

SPN 3634 Engine Intake Valve Actuation Oil Pressure for Cylinder #11

The gage pressure of the oil in the hydraulic accumulator that powers the engine intake valve for cylinder #11.

Data Length: 2 bytes

Resolution: 0.1 kPa/bit, 0 offset

Data Range: 0 to 6,425.5 kPa Operational Range: same as data range

Type: Measured

Supporting information:

PGN 64902

SPN 3635 Engine Intake Valve Actuation Oil Pressure for Cylinder #12

The gage pressure of the oil in the hydraulic accumulator that powers the engine intake valve for cylinder #12.

Data Length: 2 bytes

Resolution: 0.1 kPa/bit, 0 offset

Data Range: 0 to 6,425.5 kPa Operational Range: same as data range

Type: Measured

Supporting information:

PGN 64902

SPN 3636 Engine Intake Valve Actuation Oil Pressure for Cylinder #13

The gage pressure of the oil in the hydraulic accumulator that powers the engine intake valve for cylinder #13.

Data Length: 2 bytes

Resolution: 0.1 kPa/bit, 0 offset

Data Range: 0 to 6,425.5 kPa Operational Range: same as data range

Type: Measured

Supporting information:

PGN 64901

SPN 3637 Engine Intake Valve Actuation Oil Pressure for Cylinder #14

The gage pressure of the oil in the hydraulic accumulator that powers the engine intake valve for cylinder #14.

Data Length: 2 bytes

Resolution: 0.1 kPa/bit, 0 offset

Data Range: 0 to 6,425.5 kPa Operational Range: same as data range

Type: Measured

Supporting information:

PGN 64901

SPN 3638 Engine Intake Valve Actuation Oil Pressure for Cylinder #15

The gage pressure of the oil in the hydraulic accumulator that powers the engine intake valve for cylinder #15.

Data Length: 2 bytes

Resolution: 0.1 kPa/bit, 0 offset

Data Range: 0 to 6,425.5 kPa Operational Range: same as data range

Type: Measured

Supporting information:

PGN 64901

SPN 3639 Engine Intake Valve Actuation Oil Pressure for Cylinder #16

The gage pressure of the oil in the hydraulic accumulator that powers the engine intake valve for cylinder #16.

Data Length: 2 bytes

Resolution: 0.1 kPa/bit, 0 offset

Data Range: 0 to 6,425.5 kPa Operational Range: same as data range

Type: Measured

Supporting information:

PGN 64901

SPN 3640 Engine Intake Valve Actuation Oil Pressure for Cylinder #17

The gage pressure of the oil in the hydraulic accumulator that powers the engine intake valve for cylinder #17.

Data Length: 2 bytes

Resolution: 0.1 kPa/bit, 0 offset

Data Range: 0 to 6,425.5 kPa Operational Range: same as data range

Type: Measured

Supporting information:

PGN 64900

SPN 3641 Engine Intake Valve Actuation Oil Pressure for Cylinder #18

The gage pressure of the oil in the hydraulic accumulator that powers the engine intake valve for cylinder #18.

Data Length: 2 bytes

Resolution: 0.1 kPa/bit, 0 offset

Data Range: 0 to 6,425.5 kPa Operational Range: same as data range

Type: Measured

Supporting information:

PGN 64900

SPN 3642 Engine Intake Valve Actuation Oil Pressure for Cylinder #19

The gage pressure of the oil in the hydraulic accumulator that powers the engine intake valve for cylinder #19.

Data Length: 2 bytes

Resolution: 0.1 kPa/bit, 0 offset

Data Range: 0 to 6,425.5 kPa Operational Range: same as data range

Type: Measured

Supporting information:

PGN 64900

SPN 3643 Engine Intake Valve Actuation Oil Pressure for Cylinder #20

The gage pressure of the oil in the hydraulic accumulator that powers the engine intake valve for cylinder #20.

Data Length: 2 bytes

Resolution: 0.1 kPa/bit, 0 offset

Data Range: 0 to 6,425.5 kPa Operational Range: same as data range

Type: Measured

Supporting information:

PGN 64900

SPN 3644 Engine Derate Request

This parameter is a derate request made from the engine control system to an external system, where the engine is requesting an external device to reduce the load being applied. A zero value indicates that there is no derate being requested and 100% means full derate being requested. Any non-zero value represents a derate is being requested, at a percentage of full load. The engine control system identifies any problems and determines the amount of derate the situation calls for. This parameter can be useful to customer applications that prefer awareness and control of the engine derate.

Data Length: 1 byte

Resolution: 0.4 %/bit, 0 offset

Data Range: 0 to 100 % Operational Range: same as data range

Type: Status

Supporting information:

PGN 64914

SPN 3645 Transfer case status

This parameter describes the feedback from the transfer case controller. Used by instrument clusters, tachographs, PTOs, etc.

000 2 wheel high (normal or 'On Highway' Range)

001 4 wheel high (normal or 'On Highway' Range)

010 neutral

011 2 wheel low (or 'Off Highway' Range)

100 4 wheel low (or 'Off Highway' Range)

101 Transfer Case Shift in Progress or gear not confirmed

110 error

111 not available

Data Length: 3 bits

Resolution: 8 states/3 bit, 0 offset

Data Range: 0 to 7 Operational Range: same as data range

Type: Status

Supporting information:

PGN 64899

SPN 3667 Engine Air Shutoff Status

State signal which indicates the actual measured position of the Air Shutoff.

00 - Air flow allowed to engine
01 - Air flow restricted
10 - Error
11 - Not Available

Note: This parameter, in conjunction with SPN 2813 - "Engine Air Shutoff Command Status", is provided to allow an external system to annunciate and/or alarm on either an accidental air shutoff (shutoff detected but not commanded), or a failed air shutoff (shutoff commanded but not detected).

Data Length: 2 bits
Resolution: 4 states/2 bit, 0 offset
Data Range: 0 to 3 Operational Range: same as data range
Type: Status
Supporting information:
PGN 65252

SPN 3668 Engine Intercooler Coolant Level

Ratio of volume of liquid found in an engine intercooler cooling system to total engine intercooler cooling system volume.

Data Length: 1 byte
Resolution: 0.4 %/bit, 0 offset
Data Range: 0 to 100 % Operational Range: same as data range
Type: Measured
Supporting information:
PGN 64938

SPN 3669 Engine Rotation Direction

Direction of engine rotation, as reported by the engine. Direction convention as viewed by an observer standing at the rear of the engine, viewing the flywheel.

00 - CounterClockWise (CCW)
01 - ClockWise (CW)
10 - Reserved
11 - Not Available

Data Length: 2 bits
Resolution: 4 states/2 bit, 0 offset
Data Range: 0 to 3 Operational Range: same as data range
Type: Measured
Supporting information:
PGN 65214

SPN 3670 *Maximum Crank Attempts per Start Attempt*

The number of cranking cycles that will be performed before ending the start attempt. This is intended to be used in conjunction with Crank Attempt Count on Present Start Attempt, in order to give a FMI 0 diagnostic on the latter.

Data Length: 1 byte
 Resolution: 1 count/bit, 0 offset
 Data Range: 0 to 250 Operational Range: same as data range
 Type: Status
 Supporting information:
 PGN 64895

SPN 3671 *Crank Attempt Count on Present Start Attempt*

Reports the number of cranking cycles undergone during the present start attempt.

Note: This is intended to be used in conjunction with Maximum Crank Attempts per Start Attempt, in order to give a FMI 0 diagnostic on this parameter when the count exceeds the maximum. When the engine is not in a start attempt, this parameter can either hold the last value or return a Not Available (0xFF).

Data Length: 1 byte
 Resolution: 1 count/bit, 0 offset
 Data Range: 0 to 250 Operational Range: same as data range
 Type: Status
 Supporting information:
 PGN 65214

SPN 3672 *EGR Cooler Bypass Actuator Position*

The parameter gives the % open of the EGR Cooler Bypass Actuator, where 0% = Fully Closed (no gas flowing through the bypass), and 100% = Fully Open.

Data Length: 1 byte
 Resolution: 0.4 %/bit, 0 offset
 Data Range: 0 to 100 % Operational Range: same as data range
 Type: Measured
 Supporting information:
 PGN 64897

SPN 3673 *Engine Throttle 2 Position*

The sensed position feedback of the valve, coming from a second electrical actuator for a second throttle plate, used to regulate the supply of a fluid, usually air or fuel//air mixture. 0% represents no supply and 100% is full supply. SPN 51 is used for the first throttle position feedback.

Data Length: 1 byte
 Resolution: 0.4 %/bit, 0 offset
 Data Range: 0 to 100 % Operational Range: same as data range
 Type: Measured
 Supporting information:
 PGN 65266

SPN 3675 Engine Turbocharger Compressor Bypass Actuator Position

Measures the position of the turbocharger compressor bypass actuator, where 0% represents bypass fully closed and 100% represents bypass fully open. Typically, the compressor bypass is used to lower the compressor outlet pressure and/or intake manifold pressure during situations where too much boost is being generated by the turbocharger. Typically, a compressor bypass will be plumbed from the compressor outlet or intake manifold back to the compressor inlet, with the compressor bypass actuator and valve in place to regulate bypass flow.

Data Length: 1 byte
 Resolution: 0.4 %/bit, 0 offset
 Data Range: 0 to 100 % Operational Range: same as data range
 Type: Measured
 Supporting information:
 PGN 64931

SPN 3676 Engine Aftercooler Coolant Level

Ratio of aftercooler coolant system volume of liquid to total cooling system volume. The engine aftercooler coolant level is for the low temperature (LT) cooling circuit used for the compressor outlet air or charge aftercooling.

SPN 111 "Coolant Level" is assumed to represent a high temperature (HT) cooling circuit used for cooling the engine and its various components.

Data Length: 1 byte
 Resolution: 0.4 %/bit, 0 offset
 Data Range: 0 to 100 % Operational Range: same as data range
 Type: Measured
 Supporting information:
 PGN 64938

SPN 3683 Steering Wheel Angle

The main operator's steering wheel angle (on the steering column, not the actual wheel angle). The vehicle being steered to the left results in a positive steering wheel angle.

Data Length: 2 bytes
 Resolution: 1/1024 rad per bit, -31.374 rad offset
 Data Range: -31.374 to +31.374 rad Operational Range: same as data range
 Type: Measured
 Supporting information:
 PGN 61469

SPN 3684 Steering Wheel Angle Range Counter

The signal indicates the number of steering wheel angle range overflows if the operating range of steering wheel is greater than the measuring range of sensor element. Positive values indicate left turns. If the steering wheel angle range is +/-180 degrees this signal is equivalent to a steering wheel turn counter.

Data Length: 6 bits
 Resolution: 1 range/bit, -32 ranges offset
 Data Range: -32 to 29 ranges Operational Range: same as data range
 Type: Measured
 Supporting information:
 PGN 61469

SPN 3691 *Left Headlamp Dynamic Bending Light*

This parameter indicates whether the dynamic bending light of the left headlamp is working properly.

000 Dynamic bending light deactivated. There is no problem but for some reasons (e.g. daylight present) the bending light is deactivated.

001 Dynamic bending light is working properly. Normal operation mode. Bending light is working properly.

010 Dynamic bending light fail safe position. Bending light is damaged, current position does not affect oncoming traffic.

011 Dynamic bending light failure. Bending light does not work, current position may affect oncoming traffic.

100 – 110 Reserved

111 Not available

Data Length: 3 bits

Resolution: 8 states/3 bit, 0 offset

Data Range: 0 to 7 Operational Range: same as data range

Type: Status

Supporting information:

PGN 64894

SPN 3692 *Right Headlamp Dynamic Bending Light*

This parameter indicates whether the dynamic bending light of the left headlamp is working properly.

000 Dynamic bending light deactivated. There is no problem but for some reasons (e.g. daylight present) the bending light is deactivated.

001 Dynamic bending light is working properly. Normal operation mode. Bending light is working properly.

010 Dynamic bending light fail safe position. Bending light is damaged, current position does not affect oncoming traffic.

011 Dynamic bending light failure. Bending light does not work, current position may affect oncoming traffic.

100 – 110 Reserved

111 Not available

Data Length: 3 bits

Resolution: 8 states/3 bit, 0 offset

Data Range: 0 to 7 Operational Range: same as data range

Type: Status

Supporting information:

PGN 64894

SPN 3695 (R) Diesel Particulate Filter Regeneration Inhibit Switch

Indicates the state of a switch available to the operator that inhibits diesel particulate filter regeneration.

00 not active
01 active
10 error
11 not available

This SPN would be "not active" when diesel particulate filter regeneration is allowed to occur normally (diesel particulate filter regeneration is not inhibited).

The engine controller shall inhibit regeneration when SPN 3695 is in the ON state. Regeneration shall be activated by SPN 3696 when it is in the ON state and SPN 3695 is in the OFF state.

Data Length: 2 bits
Resolution: 4 states/2 bit, 0 offset
Data Range: 0 to 3 Operational Range: same as data range
Type: Measured
Supporting information:
PGN 57344

SPN 3696 (R) Diesel Particulate Filter Regeneration Force Switch

Indicates the state of a switch available to the operator that forces diesel particulate filter regeneration.

00 not active
01 active
10 error
11 not available

This SPN would be "not active" when diesel particulate filter regeneration is allowed to occur normally (diesel particulate filter regeneration is not being forced).

The engine controller shall inhibit regeneration when SPN 3695 is in the ON state. Regeneration shall be activated by SPN 3696 when it is in the ON state and SPN 3695 is in the OFF state.

Data Length: 2 bits
Resolution: 4 states/2 bit, 0 offset
Data Range: 0 to 3 Operational Range: same as data range
Type: Measured
Supporting information:
PGN 57344

SPN 3697 (R) Diesel Particulate Filter Lamp Command

Command to control the diesel particulate filter lamp.

000 Off
001 On – solid
010 reserved for SAE assignment
011 reserved for SAE assignment
100 On – fast blink (1 HZ)
101 reserved for SAE assignment
110 reserved for SAE assignment
111 not available

This SPN would be "off" when diesel particulate filter lamp is unlit. The "on - solid" should indicate that diesel particulate filter active regeneration is needed at the lowest level of urgency and that operator intervention is required. The flashing state indicates a more severe condition requiring regeneration.

This SPN shall not be used to convey information regarding operator switch feedback from SPNs 3695 and 3696.

The ISO 2575 Symbol F21 is recommended for use with this message.

Data Length: 3 bits
Resolution: 8 states/3 bit, 0 offset
Data Range: 0 to 7 Operational Range: same as data range
Type: Status
Supporting information: See Appendix D - SPN 3697
PGN 64892

SPN 3698 Exhaust System High Temperature Lamp Command

Command to control the exhaust system high temperature lamp. This lamp indicates that the exhaust system temperature is high.

000 Off
001 On – solid
010 reserved for SAE assignment
011 reserved for SAE assignment
100 reserved for SAE assignment
101 reserved for SAE assignment
110 reserved for SAE assignment
111 not available

This SPN would be "off" when the lamp is unlit. The "on - solid" status indicates that the exhaust gas temperature is high.

This SPN shall not be used to convey information regarding operator switch feedback from SPNs 3695 and 3696.

The ISO 2575 Symbol "to be assigned" is recommended for use with this message. This symbol is the ISO exhaust gas symbol with the temperature symbol added to it.

Data Length: 3 bits
Resolution: 8 states/3 bit, 0 offset
Data Range: 0 to 7 Operational Range: same as data range
Type: Status
Supporting information: See Appendix D - SPN 3697
PGN 64892

SPN 3699 (R) Diesel Particulate Filter Passive Regeneration Status

Indicates the state of diesel particulate filter passive regeneration.

00 not active

01 active

10 reserved for SAE assignment

11 not available

Data Length: 2 bits

Resolution: 4 states/2 bit, 0 offset

Data Range: 0 to 3 Operational Range: same as data range

Type: Status

Supporting information:

PGN 64892

SPN 3700 (R) Diesel Particulate Filter Active Regeneration Status

Indicates the state of diesel particulate filter active regeneration.

00 not active

01 active

10 regeneration needed - automatically initiated active regeneration imminent

11 not available

Data Length: 2 bits

Resolution: 4 states/2 bit, 0 offset

Data Range: 0 to 3 Operational Range: same as data range

Type: Status

Supporting information: See Appendix D - SPN 3697

PGN 64892

SPN 3701 (R) Diesel Particulate Filter Status

Indicates the state of the diesel particulate filter regeneration need and urgency.

000 Regeneration not needed

001 Regeneration needed - lowest level

010 Regeneration needed - moderate level

011 Regeneration needed - highest level

100 reserved for SAE assignment

101 reserved for SAE assignment

110 reserved for SAE assignment

111 not available

Data Length: 3 bits

Resolution: 8 states/3 bit, 0 offset

Data Range: 0 to 7 Operational Range: same as data range

Type: Status

Supporting information: See Appendix D - SPN 3697

PGN 64892

SPN 3702 (R) Diesel Particulate Filter Active Regeneration Inhibited Status

Indicates the state of diesel particulate filter active regeneration inhibition.

00 not inhibited
01 inhibited
10 reserved for SAE assignment
11 not available

This SPN indicates the reason for the diesel particulate filter regeneration not being initiated or being exited prior to completion. When this state becomes active, the system will not initiate an active regeneration or will exit an active regeneration. If the reason for inhibiting is not covered by SPNs 3703 thru 3717, a request should be submitted to the SAE Truck and Bus J1939 Request Processing Group to have the reason added.

Data Length: 2 bits
Resolution: 4 states/2 bit, 0 offset
Data Range: 0 to 3 Operational Range: same as data range
Type: Status
Supporting information:
PGN 64892

SPN 3703 (R) Diesel Particulate Filter Active Regeneration Inhibited Due to Inhibit Switch

Indicates the state of diesel particulate filter active regeneration inhibition due to the Diesel Particulate Filter Regeneration Inhibit Switch.

00 not inhibited
01 inhibited
10 reserved for SAE assignment
11 not available

This SPN indicates the reason for the diesel particulate filter regeneration not being initiated or being exited prior to completion. When this state becomes active the system will not initiate an active regeneration or will exit an active regeneration. The state provides information that may be provided to the driver/service technician as to why the regeneration did not initiate or was exited.

Data Length: 2 bits
Resolution: 4 states/2 bit, 0 offset
Data Range: 0 to 3 Operational Range: same as data range
Type: Status
Supporting information: See Appendix D - SPN 3697
PGN 64892

SPN 3704 (R) Diesel Particulate Filter Active Regeneration Inhibited Due to Clutch Disengaged

Indicates the state of diesel particulate filter active regeneration inhibition due to the clutch being disengaged.

00 not inhibited
01 inhibited
10 reserved for SAE assignment
11 not available

This SPN indicates the reason for the diesel particulate filter regeneration not being initiated or being exited prior to completion. When this state becomes active the system will not initiate an active regeneration or will exit an active regeneration. The state provides information that may be provided to the driver/service technician as to why the regeneration did not initiate or was exited.

Data Length: 2 bits
Resolution: 4 states/2 bit, 0 offset
Data Range: 0 to 3 Operational Range: same as data range
Type: Status
Supporting information:
PGN 64892

SPN 3705 (R) Diesel Particulate Filter Active Regeneration Inhibited Due to Service Brake Active

Indicates the state of diesel particulate filter active regeneration inhibition due to the service brake being active.

00 not inhibited
01 inhibited
10 reserved for SAE assignment
11 not available

This SPN indicates the reason for the diesel particulate filter regeneration not being initiated or being exited prior to completion. When this state becomes active the system will not initiate an active regeneration or will exit an active regeneration. The state provides information that may be provided to the driver/service technician as to why the regeneration did not initiate or was exited.

Data Length: 2 bits
Resolution: 4 states/2 bit, 0 offset
Data Range: 0 to 3 Operational Range: same as data range
Type: Status
Supporting information:
PGN 64892

SPN 3706 (R) Diesel Particulate Filter Active Regeneration Inhibited Due to PTO Active

Indicates the state of diesel particulate filter active regeneration inhibition due to the PTO being active.

00 not inhibited
01 inhibited
10 reserved for SAE assignment
11 not available

This SPN indicates the reason for the diesel particulate filter regeneration not being initiated or being exited prior to completion. When this state becomes active the system will not initiate an active regeneration or will exit an active regeneration. The state provides information that may be provided to the driver/service technician as to why the regeneration did not initiate or was exited.

Data Length: 2 bits
Resolution: 4 states/2 bit, 0 offset
Data Range: 0 to 3 Operational Range: same as data range
Type: Status
Supporting information:
PGN 64892

SPN 3707 (R) Diesel Particulate Filter Active Regeneration Inhibited Due to Accelerator Pedal Off Idle

Indicates the state of diesel particulate filter active regeneration inhibition due to the accelerator pedal being off idle.

00 not inhibited
01 inhibited
10 reserved for SAE assignment
11 not available

This SPN indicates the reason for the diesel particulate filter regeneration not being initiated or being exited prior to completion. When this state becomes active the system will not initiate an active regeneration or will exit an active regeneration. The state provides information that may be provided to the driver/service technician as to why the regeneration did not initiate or was exited.

Data Length: 2 bits
Resolution: 4 states/2 bit, 0 offset
Data Range: 0 to 3 Operational Range: same as data range
Type: Status
Supporting information:
PGN 64892

SPN 3708 (R) Diesel Particulate Filter Active Regeneration Inhibited Due to Out of Neutral

Indicates the state of diesel particulate filter active regeneration inhibition due to the transmission being out of neutral.

00 not inhibited
01 inhibited
10 reserved for SAE assignment
11 not available

This SPN indicates the reason for the diesel particulate filter regeneration not being initiated or being exited prior to completion. When this state becomes active the system will not initiate an active regeneration or will exit an active regeneration. The state provides information that may be provided to the driver/service technician as to why the regeneration did not initiate or was exited.

Data Length: 2 bits
Resolution: 4 states/2 bit, 0 offset
Data Range: 0 to 3 Operational Range: same as data range
Type: Status
Supporting information:
PGN 64892

SPN 3709 (R) Diesel Particulate Filter Active Regeneration Inhibited Due to Vehicle Speed Above Allowed Speed

Indicates the state of diesel particulate filter active regeneration inhibition due to the vehicle speed being above an allowed limit.

00 not inhibited
01 inhibited
10 reserved for SAE assignment
11 not available

This SPN indicates the reason for the diesel particulate filter regeneration not being initiated or being exited prior to completion. When this state becomes active the system will not initiate an active regeneration or will exit an active regeneration. The state provides information that may be provided to the driver/service technician as to why the regeneration did not initiate or was exited.

Data Length: 2 bits
Resolution: 4 states/2 bit, 0 offset
Data Range: 0 to 3 Operational Range: same as data range
Type: Status
Supporting information:
PGN 64892

SPN 3710 (R) Diesel Particulate Filter Active Regeneration Inhibited Due to Parking Brake Not Set

Indicates the state of diesel particulate filter active regeneration inhibition due to the parking brake being not set.

00 not inhibited
01 inhibited
10 reserved for SAE assignment
11 not available

This SPN indicates the reason for the diesel particulate filter regeneration not being initiated or being exited prior to completion. When this state becomes active the system will not initiate an active regeneration or will exit an active regeneration. The state provides information that may be provided to the driver/service technician as to why the regeneration did not initiate or was exited.

Data Length: 2 bits
Resolution: 4 states/2 bit, 0 offset
Data Range: 0 to 3 Operational Range: same as data range
Type: Status
Supporting information:
PGN 64892

SPN 3711 (R) Diesel Particulate Filter Active Regeneration Inhibited Due to Low Exhaust Gas Temperature

Indicates the state of diesel particulate filter active regeneration inhibition due to the exhaust gas temperature being too low. This implies that the diesel particulate filter and/or oxidation catalyst are likewise too cold for active regeneration.

00 not inhibited
01 inhibited
10 reserved for SAE assignment
11 not available

This SPN indicates the reason for the diesel particulate filter regeneration not being initiated or being exited prior to completion. When this state becomes active the system will not initiate an active regeneration or will exit an active regeneration. The state provides information that may be provided to the driver/service technician as to why the regeneration did not initiate or was exited.

Data Length: 2 bits
Resolution: 4 states/2 bit, 0 offset
Data Range: 0 to 3 Operational Range: same as data range
Type: Measured
Supporting information:
PGN 64892

SPN 3712 (R) Diesel Particulate Filter Active Regeneration Inhibited Due to System Fault Active

Indicates the state of diesel particulate filter active regeneration inhibition due to a system fault being active.

00 not inhibited
01 inhibited
10 reserved for SAE assignment
11 not available

This SPN indicates the reason for the diesel particulate filter regeneration not being initiated or being exited prior to completion. When this state becomes active the system will not initiate an active regeneration or will exit an active regeneration. The state provides information that may be provided to the driver/service technician as to why the regeneration did not initiate or was exited.

Data Length: 2 bits
Resolution: 4 states/2 bit, 0 offset
Data Range: 0 to 3 Operational Range: same as data range
Type: Status
Supporting information:
PGN 64892

SPN 3713 (R) Diesel Particulate Filter Active Regeneration Inhibited Due to System Timeout

Indicates the state of diesel particulate filter active regeneration inhibition due to a system timeout.

00 not inhibited
01 inhibited
10 reserved for SAE assignment
11 not available

This SPN indicates the reason for the diesel particulate filter regeneration not being initiated or being exited prior to completion. When this state becomes active the system will not initiate an active regeneration or will exit an active regeneration. The state provides information that may be provided to the driver/service technician as to why the regeneration did not initiate or was exited.

Data Length: 2 bits
Resolution: 4 states/2 bit, 0 offset
Data Range: 0 to 3 Operational Range: same as data range
Type: Status
Supporting information:
PGN 64892

SPN 3714 (R) Diesel Particulate Filter Active Regeneration Inhibited Due to Temporary System Lockout

Indicates the state of diesel particulate filter active regeneration inhibition due to a temporary system lockout.

00 not inhibited
01 inhibited
10 reserved for SAE assignment
11 not available

This SPN indicates the reason for the diesel particulate filter regeneration not being initiated or being exited prior to completion. When this state becomes active the system will not initiate an active regeneration or will exit an active regeneration. The state provides information that may be provided to the driver/service technician as to why the regeneration did not initiate or was exited.

Data Length: 2 bits
Resolution: 4 states/2 bit, 0 offset
Data Range: 0 to 3 Operational Range: same as data range
Type: Status
Supporting information:
PGN 64892

SPN 3715 (R) Diesel Particulate Filter Active Regeneration Inhibited Due to Permanent System Lockout

Indicates the state of diesel particulate filter active regeneration inhibition due to a permanent system lockout.

00 not inhibited
01 inhibited
10 reserved for SAE assignment
11 not available

This SPN indicates the reason for the diesel particulate filter regeneration not being initiated or being exited prior to completion. When this state becomes active the system will not initiate an active regeneration or will exit an active regeneration. The state provides information that may be provided to the driver/service technician as to why the regeneration did not initiate or was exited.

Data Length: 2 bits
Resolution: 4 states/2 bit, 0 offset
Data Range: 0 to 3 Operational Range: same as data range
Type: Measured
Supporting information:
PGN 64892

SPN 3716 (R) Diesel Particulate Filter Active Regeneration Inhibited Due to Engine Not Warmed Up

Indicates the state of diesel particulate filter active regeneration inhibition due to the engine not being warmed up.

00 not inhibited
 01 inhibited
 10 reserved for SAE assignment
 11 not available

This SPN indicates the reason for the diesel particulate filter regeneration not being initiated or being exited prior to completion. When this state becomes active the system will not initiate an active regeneration or will exit an active regeneration. The state provides information that may be provided to the driver/service technician as to why the regeneration did not initiate or was exited.

Data Length: 2 bits
 Resolution: 4 states/2 bit, 0 offset
 Data Range: 0 to 3 Operational Range: same as data range
 Type: Status
 Supporting information:
 PGN 64892

SPN 3717 (R) Diesel Particulate Filter Active Regeneration Inhibited Due to Vehicle Speed Below Allowed Speed

Indicates the state of diesel particulate filter active regeneration inhibition due to vehicle speed being less than the allowed vehicle speed.

00 not inhibited
 01 inhibited
 10 reserved for SAE assignment
 11 not available

This SPN indicates the reason for the diesel particulate filter regeneration not being initiated or being exited prior to completion. When this state becomes active the system will not initiate an active regeneration or will exit an active regeneration. The state provides information that may be provided to the driver/service technician as to why the regeneration did not initiate or was exited.

Data Length: 2 bits
 Resolution: 4 states/2 bit, 0 offset
 Data Range: 0 to 3 Operational Range: same as data range
 Type: Status
 Supporting information:
 PGN 64892

SPN 3718 (R) Diesel Particulate Filter Automatic Active Regeneration Initiation Configuration

Indicates the configuration of diesel particulate filter active regeneration automatic initiation.

00 not enabled
 01 enabled
 10 reserved for SAE assignment
 11 not available

Data Length: 2 bits
 Resolution: 4 states/2 bit, 0 offset
 Data Range: 0 to 3 Operational Range: same as data range
 Type: Status
 Supporting information:
 PGN 64892

SPN 3719 (R) Diesel Particulate Filter 1 Soot Load Percent

Indicates the soot load percent of diesel particulate filter 1. 100% is the level at which active diesel particulate filter regeneration should be triggered.

100% level is the active regeneration trigger level (and if conditions are not favorable for regeneration, soot loading can continue beyond 100%). During normal operation and regeneration a value 0% will indicate a fully regenerated diesel particulate filter. Values of 25%, 50% and 75% will indicate the general level of soot prior to the 100% level where an active regeneration is needed.

Data Length: 1 byte
Resolution: 1 %/bit, 0 offset
Data Range: 0 to 250 % Operational Range: same as data range
Type: Measured
Supporting information:
PGN 64891

SPN 3720 (R) Diesel Particulate Filter 1 Ash Load Percent

Indicates the ash load percent of diesel particulate filter 1. 100% is the level at which diesel particulate filter ash service should be performed.

100% level is the target ash service interval (and if ash service is not immediately performed, ash loading can continue beyond 100%).

Data Length: 1 byte
Resolution: 1 %/bit, 0 offset
Data Range: 0 to 250 % Operational Range: same as data range
Type: Measured
Supporting information:
PGN 64891

SPN 3721 (R) Diesel Particulate Filter 1 Time Since Last Active Regeneration

Indicates the time since the last active regeneration event of diesel particulate filter 1.

Data Length: 4 bytes
Resolution: 1 s/bit, 0 offset
Data Range: 0 to 4,211,081,215 s Operational Range: same as data range
Type: Measured
Supporting information:
PGN 64891

SPN 3722 (R) Diesel Particulate Filter 2 Soot Load Percent

Indicates the soot load percent of diesel particulate filter 2. 100% is the level at which active diesel particulate filter regeneration should be triggered.

100% level is the active regeneration trigger level (and if conditions are not favorable for regeneration, soot loading can continue beyond 100%). During normal operation and regeneration a value 0% will indicate a fully regenerated diesel particulate filter. Values of 25%, 50% and 75% will indicate the general level of soot prior to the 100% level where an active regeneration is needed.

Data Length: 1 byte
 Resolution: 1 %/bit, 0 offset
 Data Range: 0 to 250 % Operational Range: same as data range
 Type: Measured
 Supporting information:
 PGN 64890

SPN 3723 (R) Diesel Particulate Filter 2 Ash Load Percent

Indicates the ash load percent of diesel particulate filter 2. 100% is the level at which diesel particulate filter ash service should be performed.

100% level is the target ash service interval (and if ash service is not immediately performed, ash loading can continue beyond 100%).

Data Length: 1 byte
 Resolution: 1 %/bit, 0 offset
 Data Range: 0 to 250 % Operational Range: same as data range
 Type: Measured
 Supporting information:
 PGN 64890

SPN 3724 (R) Diesel Particulate Filter 2 Time Since Last Active Regeneration

Indicates the time since the last active regeneration event of diesel particulate filter 2.

Data Length: 4 bytes
 Resolution: 1 s/bit, 0 offset
 Data Range: 0 to 4,211,081,215 s Operational Range: same as data range
 Type: Measured
 Supporting information:
 PGN 64890

SPN 3725 Aftertreatment 1 Total Passive Regeneration Time

Total amount of time that aftertreatment device 1 has been in passive regeneration over the lifetime of the device.

Data Length: 4 bytes
 Resolution: 1 s/bit, 0 offset
 Data Range: 0 to 4,211,081,215 s Operational Range: same as data range
 Type: Measured
 Supporting information:
 PGN 64920

SPN 3726 *Aftertreatment 1 Total Number of Passive Regenerations*

Total number of passive regenerations by aftertreatment device 1 over the lifetime of the device.

Data Length: 4 bytes

Resolution: 1 count/bit, 0 offset

Data Range: 0 to 4,294,967,295 counts Operational Range: same as data range

Type: Measured

Supporting information:

PGN 64920

SPN 3727 *Aftertreatment 1 Total Number of Active Regeneration Inhibit Requests*

Total number of aftertreatment device 1 active regeneration inhibit requests by the operator over the lifetime of the device.

Data Length: 4 bytes

Resolution: 1 count/bit, 0 offset

Data Range: 0 to 4,294,967,295 counts Operational Range: same as data range

Type: Measured

Supporting information:

PGN 64920

SPN 3728 *Aftertreatment 1 Total Number of Active Regeneration Manual Requests*

Total number of aftertreatment device 1 active regeneration manual requests by the operator over the lifetime of the device.

Data Length: 4 bytes

Resolution: 1 count/bit, 0 offset

Data Range: 0 to 4,294,967,295 counts Operational Range: same as data range

Type: Measured

Supporting information:

PGN 64920

SPN 3729 *Aftertreatment 2 Total Passive Regeneration Time*

Total amount of time that Aftertreatment device 2 has been in passive regeneration over the lifetime of the device.

Data Length: 4 bytes

Resolution: 1 s/bit, 0 offset

Data Range: 0 to 4,211,081,215 s Operational Range: same as data range

Type: Measured

Supporting information:

PGN 64921

SPN 3730 *Aftertreatment 2 Total Number of Passive Regenerations*

Total number of passive regenerations by Aftertreatment device 2 over the lifetime of the device.

Data Length: 4 bytes

Resolution: 1 count/bit, 0 offset

Data Range: 0 to 4,294,967,295 counts Operational Range: same as data range

Type: Measured

Supporting information:

PGN 64921

SPN 3731 *Aftertreatment 2 Total Number of Active Regeneration Inhibit Requests*

Total number of Aftertreatment device 2 active regeneration inhibit requests by the operator over the lifetime of the device.

Data Length: 4 bytes

Resolution: 1 count/bit, 0 offset

Data Range: 0 to 4,294,967,295 counts Operational Range: same as data range

Type: Measured

Supporting information:

PGN 64921

SPN 3732 *Aftertreatment 2 Total Number of Active Regeneration Manual Requests*

Total number of Aftertreatment device 2 active regeneration manual requests by the operator over the lifetime of the device.

Data Length: 4 bytes

Resolution: 1 count/bit, 0 offset

Data Range: 0 to 4,294,967,295 counts Operational Range: same as data range

Type: Measured

Supporting information:

PGN 64921

SPN 3733 *Aftertreatment 1 Trip Fuel Used*

Total amount of fuel used by aftertreatment device 1 during the current trip period.

NOTE: This SPN needs to be reset by the reset PGN 56832.

Data Length: 4 bytes

Resolution: 0.5 L/bit, 0 offset

Data Range: 0 to 2,105,540,607.5 L Operational Range: same as data range

Type: Measured

Supporting information:

PGN 64889

SPN 3734 *Aftertreatment 1 Trip Active Regeneration Time*

Total amount of time that aftertreatment device 1 has been in active regeneration during the current trip period.

NOTE: This SPN needs to be reset by the reset PGN 56832.

Data Length: 4 bytes
Resolution: 1 s/bit, 0 offset
Data Range: 0 to 4,211,081,215 s Operational Range: same as data range
Type: Measured
Supporting information:
PGN 64889

SPN 3735 *Aftertreatment 1 Trip Disabled Time*

Total amount of time that aftertreatment 1 regeneration has been manually disabled during the current trip period.

NOTE: This SPN needs to be reset by the reset PGN 56832.

Data Length: 4 bytes
Resolution: 1 s/bit, 0 offset
Data Range: 0 to 4,211,081,215 s Operational Range: same as data range
Type: Measured
Supporting information:
PGN 64889

SPN 3736 *Aftertreatment 1 Trip Number of Active Regenerations*

Total number of active regenerations by Aftertreatment device 1 during the current trip period.

NOTE: This SPN needs to be reset by the reset PGN 56832.

Data Length: 4 bytes
Resolution: 1 count/bit, 0 offset
Data Range: 0 to 4,294,967,295 counts Operational Range: same as data range
Type: Measured
Supporting information:
PGN 64889

SPN 3737 *Aftertreatment 1 Trip Passive Regeneration Time*

Total amount of time that aftertreatment device 1 has been in passive regeneration during the current trip period.

NOTE: This SPN needs to be reset by the reset PGN 56832.

Data Length: 4 bytes
Resolution: 1 s/bit, 0 offset
Data Range: 0 to 4,211,081,215 s Operational Range: same as data range
Type: Measured
Supporting information:
PGN 64889

SPN 3738 *Aftertreatment 1 Trip Number of Passive Regenerations*

Total number of passive regenerations by Aftertreatment device 1 during the current trip period.

NOTE: This SPN needs to be reset by the reset PGN 56832.

Data Length: 4 bytes
Resolution: 1 count/bit, 0 offset
Data Range: 0 to 4,294,967,295 counts Operational Range: same as data range
Type: Measured
Supporting information:
PGN 64889

SPN 3739 *Aftertreatment 1 Trip Number of Active Regeneration Inhibit Requests*

Total number of aftertreatment device 1 active regeneration inhibit requests by the operator during the current trip period.

NOTE: This SPN needs to be reset by the reset PGN 56832.

Data Length: 4 bytes
Resolution: 1 count/bit, 0 offset
Data Range: 0 to 4,294,967,295 counts Operational Range: same as data range
Type: Measured
Supporting information:
PGN 64889

SPN 3740 *Aftertreatment 1 Trip Number of Active Regeneration Manual Requests*

Total number of Aftertreatment device 1 active regeneration manual requests by the operator during the current trip period.

Data Length: 4 bytes
Resolution: 1 count/bit, 0 offset
Data Range: 0 to 4,294,967,295 counts Operational Range: same as data range
Type: Measured
Supporting information:
PGN 64889

SPN 3741 *Aftertreatment 2 Trip Fuel Used*

Total amount of fuel used by aftertreatment device 2 during the current trip period.

NOTE: This SPN needs to be reset by the reset PGN 56832.

Data Length: 4 bytes
Resolution: 0.5 L/bit, 0 offset
Data Range: 0 to 2,105,540,607.5 L Operational Range: same as data range
Type: Measured
Supporting information:
PGN 64888

SPN 3742 *Aftertreatment 2 Trip Active Regeneration Time*

Total amount of time that aftertreatment device 2 has been in active regeneration during the current trip period.

NOTE: This SPN needs to be reset by the reset PGN 56832.

Data Length: 4 bytes
Resolution: 1 s/bit, 0 offset
Data Range: 0 to 4,211,081,215 s Operational Range: same as data range
Type: Measured
Supporting information:
PGN 64888

SPN 3743 *Aftertreatment 2 Trip Disabled Time*

Total amount of time that aftertreatment 2 regeneration has been manually disabled during the current trip period.

NOTE: This SPN needs to be reset by the reset PGN 56832.

Data Length: 4 bytes
Resolution: 1 s/bit, 0 offset
Data Range: 0 to 4,211,081,215 s Operational Range: same as data range
Type: Measured
Supporting information:
PGN 64888

SPN 3744 *Aftertreatment 2 Trip Number of Active Regenerations*

Total number of active regenerations by aftertreatment device 2 during the current trip period.

NOTE: This SPN needs to be reset by the reset PGN 56832.

Data Length: 4 bytes
Resolution: 1 count/bit, 0 offset
Data Range: 0 to 4,294,967,295 counts Operational Range: same as data range
Type: Measured
Supporting information:
PGN 64888

SPN 3745 *Aftertreatment 2 Trip Passive Regeneration Time*

Total amount of time that aftertreatment device 2 has been in passive regeneration during the current trip period.

NOTE: This SPN needs to be reset by the reset PGN 56832.

Data Length: 4 bytes
Resolution: 1 s/bit, 0 offset
Data Range: 0 to 4,211,081,215 s Operational Range: same as data range
Type: Measured
Supporting information:
PGN 64888

SPN 3746 *Aftertreatment 2 Trip Number of Passive Regenerations*

Total number of passive regenerations by aftertreatment device 2 during the current trip period.

NOTE: This SPN needs to be reset by the reset PGN 56832.

Data Length: 4 bytes
 Resolution: 1 count/bit, 0 offset
 Data Range: 0 to 4,294,967,295 counts Operational Range: same as data range
 Type: Measured
 Supporting information:
 PGN 64888

SPN 3747 *Aftertreatment 2 Trip Number of Active Regeneration Inhibit Requests*

Total number of aftertreatment device 2 active regeneration inhibit requests by the operator during the current trip period.

NOTE: This SPN needs to be reset by the reset PGN 56832.

Data Length: 4 bytes
 Resolution: 1 count/bit, 0 offset
 Data Range: 0 to 4,294,967,295 counts Operational Range: same as data range
 Type: Measured
 Supporting information:
 PGN 64888

SPN 3748 *Aftertreatment 2 Trip Number of Active Regeneration Manual Requests*

Total number of aftertreatment device 2 active regeneration manual requests by the operator during the current trip period.

Data Length: 4 bytes
 Resolution: 1 count/bit, 0 offset
 Data Range: 0 to 4,294,967,295 counts Operational Range: same as data range
 Type: Measured
 Supporting information:
 PGN 64888

SPN 3785 *Tractor Brake Stroke Axle 1 Left*

Brake stroke status for left brake actuator on tractor axle 1.

000 - OK (Normal operation)
 001 - Non-functioning
 010 - Overstroke
 011 - Dragging brake
 100 - Reserved
 101 - Reserved
 110 - Sensor error
 111 - Not available

Data Length: 3 bits
 Resolution: 8 states/3 bit, 0 offset
 Data Range: 0 to 7 Operational Range: same as data range
 Type: Status
 Supporting information: See Appendix D - SPN 3785
 PGN 64881

SPN 3786 Tractor Brake Stroke Axle 1 Right

Brake stroke status for right brake actuator on tractor axle 1.

000 - OK (Normal operation)
001 - Non-functioning
010 - Overstroke
011 - Dragging brake
100 - Reserved
101 - Reserved
110 - Sensor error
111 - Not available

Data Length: 3 bits
Resolution: 8 states/3 bit, 0 offset
Data Range: 0 to 7 Operational Range: same as data range
Type: Status
Supporting information: See Appendix D - SPN 3785
PGN 64881

SPN 3787 Tractor Brake Stroke Axle 2 Left

Brake stroke status for left brake actuator on tractor axle 2.

000 - OK (Normal operation)
001 - Non-functioning
010 - Overstroke
011 - Dragging brake
100 - Reserved
101 - Reserved
110 - Sensor error
111 - Not available

Data Length: 3 bits
Resolution: 8 states/3 bit, 0 offset
Data Range: 0 to 7 Operational Range: same as data range
Type: Status
Supporting information: See Appendix D - SPN 3785
PGN 64881

SPN 3788 Tractor Brake Stroke Axle 2 Right

Brake stroke status for right brake actuator on tractor axle 2.

000 - OK (Normal operation)
001 - Non-functioning
010 - Overstroke
011 - Dragging brake
100 - Reserved
101 - Reserved
110 - Sensor error
111 - Not available

Data Length: 3 bits
Resolution: 8 states/3 bit, 0 offset
Data Range: 0 to 7 Operational Range: same as data range
Type: Status
Supporting information: See Appendix D - SPN 3785
PGN 64881

SPN 3789 Tractor Brake Stroke Axle 3 Left

Brake stroke status for left brake actuator on tractor axle 3.

000 - OK (Normal operation)
001 - Non-functioning
010 - Overstroke
011 - Dragging brake
100 - Reserved
101 - Reserved
110 - Sensor error
111 - Not available

Data Length: 3 bits
Resolution: 8 states/3 bit, 0 offset
Data Range: 0 to 7 Operational Range: same as data range
Type: Status
Supporting information: See Appendix D - SPN 3785
PGN 64881

SPN 3790 Tractor Brake Stroke Axle 3 Right

Brake stroke status for right brake actuator on tractor axle 3.

000 - OK (Normal operation)
001 - Non-functioning
010 - Overstroke
011 - Dragging brake
100 - Reserved
101 - Reserved
110 - Sensor error
111 - Not available

Data Length: 3 bits
Resolution: 8 states/3 bit, 0 offset
Data Range: 0 to 7 Operational Range: same as data range
Type: Status
Supporting information: See Appendix D - SPN 3785
PGN 64881

SPN 3791 Tractor Brake Stroke Axle 4 Left

Brake stroke status for left brake actuator on tractor axle 4.

000 - OK (Normal operation)
001 - Non-functioning
010 - Overstroke
011 - Dragging brake
100 - Reserved
101 - Reserved
110 - Sensor error
111 - Not available

Data Length: 3 bits
Resolution: 8 states/3 bit, 0 offset
Data Range: 0 to 7 Operational Range: same as data range
Type: Status
Supporting information: See Appendix D - SPN 3785
PGN 64881

SPN 3792 Tractor Brake Stroke Axle 4 Right

Brake stroke status for right brake actuator on tractor axle 4.

000 - OK (Normal operation)
001 - Non-functioning
010 - Overstroke
011 - Dragging brake
100 - Reserved
101 - Reserved
110 - Sensor error
111 - Not available

Data Length: 3 bits
Resolution: 8 states/3 bit, 0 offset
Data Range: 0 to 7 Operational Range: same as data range
Type: Status
Supporting information: See Appendix D - SPN 3785
PGN 64881

SPN 3793 Tractor Brake Stroke Axle 5 Left

Brake stroke status for left brake actuator on tractor axle 5.

000 - OK (Normal operation)
001 - Non-functioning
010 - Overstroke
011 - Dragging brake
100 - Reserved
101 - Reserved
110 - Sensor error
111 - Not available

Data Length: 3 bits
Resolution: 8 states/3 bit, 0 offset
Data Range: 0 to 7 Operational Range: same as data range
Type: Status
Supporting information: See Appendix D - SPN 3785
PGN 64881

SPN 3794 Tractor Brake Stroke Axle 5 Right

Brake stroke status for right brake actuator on tractor axle 5.

000 - OK (Normal operation)
001 - Non-functioning
010 - Overstroke
011 - Dragging brake
100 - Reserved
101 - Reserved
110 - Sensor error
111 - Not available

Data Length: 3 bits
Resolution: 8 states/3 bit, 0 offset
Data Range: 0 to 7 Operational Range: same as data range
Type: Status
Supporting information: See Appendix D - SPN 3785
PGN 64881

SPN 3795 Trailer Brake Stroke Axle 1 Left

Brake stroke status for left brake actuator on trailer axle 1.

000 - OK (Normal operation)
001 - Non-functioning
010 - Overstroke
011 - Dragging brake
100 - Reserved
101 - Reserved
110 - Sensor error
111 - Not available

Data Length: 3 bits
Resolution: 8 states/3 bit, 0 offset
Data Range: 0 to 7 Operational Range: same as data range
Type: Status
Supporting information: See Appendix D - SPN 3785
PGN 64881

SPN 3796 Trailer Brake Stroke Axle 1 Right

Brake stroke status for right brake actuator on trailer axle 1.

000 - OK (Normal operation)
001 - Non-functioning
010 - Overstroke
011 - Dragging brake
100 - Reserved
101 - Reserved
110 - Sensor error
111 - Not available

Data Length: 3 bits
Resolution: 8 states/3 bit, 0 offset
Data Range: 0 to 7 Operational Range: same as data range
Type: Status
Supporting information: See Appendix D - SPN 3785
PGN 64881

SPN 3797 Trailer Brake Stroke Axle 2 Left

Brake stroke status for left brake actuator on trailer axle 2.

000 - OK (Normal operation)
001 - Non-functioning
010 - Overstroke
011 - Dragging brake
100 - Reserved
101 - Reserved
110 - Sensor error
111 - Not available

Data Length: 3 bits
Resolution: 8 states/3 bit, 0 offset
Data Range: 0 to 7 Operational Range: same as data range
Type: Status
Supporting information: See Appendix D - SPN 3785
PGN 64881

SPN 3798 Trailer Brake Stroke Axle 2 Right

Brake stroke status for right brake actuator on trailer axle 2.

000 - OK (Normal operation)
001 - Non-functioning
010 - Overstroke
011 - Dragging brake
100 - Reserved
101 - Reserved
110 - Sensor error
111 - Not available

Data Length: 3 bits
Resolution: 8 states/3 bit, 0 offset
Data Range: 0 to 7 Operational Range: same as data range
Type: Status
Supporting information: See Appendix D - SPN 3785
PGN 64881

SPN 3799 Trailer Brake Stroke Axle 3 Left

Brake stroke status for left brake actuator on trailer axle 3.

000 - OK (Normal operation)
001 - Non-functioning
010 - Overstroke
011 - Dragging brake
100 - Reserved
101 - Reserved
110 - Sensor error
111 - Not available

Data Length: 3 bits
Resolution: 8 states/3 bit, 0 offset
Data Range: 0 to 7 Operational Range: same as data range
Type: Status
Supporting information: See Appendix D - SPN 3785
PGN 64881

SPN 3800 Trailer Brake Stroke Axle 3 Right

Brake stroke status for right brake actuator on trailer axle 3.

000 - OK (Normal operation)
001 - Non-functioning
010 - Overstroke
011 - Dragging brake
100 - Reserved
101 - Reserved
110 - Sensor error
111 - Not available

Data Length: 3 bits
Resolution: 8 states/3 bit, 0 offset
Data Range: 0 to 7 Operational Range: same as data range
Type: Status
Supporting information: See Appendix D - SPN 3785
PGN 64881

SPN 3801 Trailer Brake Stroke Axle 4 Left

Brake stroke status for left brake actuator on trailer axle 4.

000 - OK (Normal operation)
001 - Non-functioning
010 - Overstroke
011 - Dragging brake
100 - Reserved
101 - Reserved
110 - Sensor error
111 - Not available

Data Length: 3 bits
Resolution: 8 states/3 bit, 0 offset
Data Range: 0 to 7 Operational Range: same as data range
Type: Status
Supporting information: See Appendix D - SPN 3785
PGN 64881

SPN 3802 Trailer Brake Stroke Axle 4 Right

Brake stroke status for right brake actuator on trailer axle 4.

000 - OK (Normal operation)
001 - Non-functioning
010 - Overstroke
011 - Dragging brake
100 - Reserved
101 - Reserved
110 - Sensor error
111 - Not available

Data Length: 3 bits
Resolution: 8 states/3 bit, 0 offset
Data Range: 0 to 7 Operational Range: same as data range
Type: Status
Supporting information: See Appendix D - SPN 3785
PGN 64881

SPN 3803 Trailer Brake Stroke Axle 5 Left

Brake stroke status for left brake actuator on trailer axle 5.

000 - OK (Normal operation)
001 - Non-functioning
010 - Overstroke
011 - Dragging brake
100 - Reserved
101 - Reserved
110 - Sensor error
111 - Not available

Data Length: 3 bits
Resolution: 8 states/3 bit, 0 offset
Data Range: 0 to 7 Operational Range: same as data range
Type: Status
Supporting information: See Appendix D - SPN 3785
PGN 64881

SPN 3804 Trailer Brake Stroke Axle 5 Right

Brake stroke status for right brake actuator on trailer axle 5.

000 - OK (Normal operation)
 001 - Non-functioning
 010 - Overstroke
 011 - Dragging brake
 100 - Reserved
 101 - Reserved
 110 - Sensor error
 111 - Not available

Data Length: 3 bits
 Resolution: 8 states/3 bit, 0 offset
 Data Range: 0 to 7 Operational Range: same as data range
 Type: Status
 Supporting information: See Appendix D - SPN 3785
 PGN 64881

SPN 3807 Park Brake Release Inhibit Request

Park Brake Release Inhibit Request signals the desire that an applied park brake remain applied and limit the ability of the vehicle to be moved.

00 - Park Brake Release Inhibit not requested
 01 - Park Brake Release Inhibit requested
 10 - SAE reserved
 11 - Unavailable

This parameter provides the capability to request the device controlling a parking brake to inhibit its release. This is intended for devices to request the park brake remain applied. Status 00b is provided when conditions recommending the application of the park brake no longer exist for the sender.

Data Length: 2 bits
 Resolution: 4 states/2 bit, 0 offset
 Data Range: 0 to 3 Operational Range: same as data range
 Type: Status
 Supporting information:
 PGN 65265

SPN 3808 Park Brake Release Inhibit Status

This parameter provides reports on the status of the Park Brake Release Inhibit function.

00 - Park Brake release is not inhibited
 01 - Park Brake release is inhibited
 10 - Error (for example: Park Brake release is not inhibited, but is requested to be inhibited)
 11 - Unavailable

The device controlling the Park Brake sends a status of the inhibit function. The allowed release of the park brake is provided as status 00b. 01b indicates that the release of the park brake is inhibited. The release may be inhibited by either an external request or by local information available to the controlling device.

Data Length: 2 bits
 Resolution: 4 states/2 bit, 0 offset
 Data Range: 0 to 3 Operational Range: same as data range
 Type: Measured
 Supporting information:
 PGN 65274

SPN 3809 *Transmission Oil Level Request*

Conveys operator or vehicle system desire for a transmission oil level reading to be taken.

00 - No transmission oil level reading desired
01 - Transmission oil level reading desired
10 - Reserved
11 - Don't care / take no action

Data Length: 2 bits
Resolution: 4 states/2 bit, 0 offset
Data Range: 0 to 3 Operational Range: same as data range
Type: Status
Supporting information:
PGN 64980

SPN 3810 *Retract Status of ramp 1*

Retract status of ramp at doorway 1, counting from front to back on the vehicle.

Bit States:
00 ramp retracted
01 ramp extended
10 error
11 not available

Data Length: 2 bits
Resolution: 4 states/2 bit, 0 offset
Data Range: 0 to 3 Operational Range: same as data range
Type: Status
Supporting information:
PGN 64880

SPN 3811 *Enable status of ramp 1*

Enable status of ramp at doorway 1, counting from front to back on the vehicle.

Bit States:
00 ramp disabled
01 ramp enabled
10 error
11 not available

Data Length: 2 bits
Resolution: 4 states/2 bit, 0 offset
Data Range: 0 to 3 Operational Range: same as data range
Type: Status
Supporting information:
PGN 64880

SPN 3812 *Movement status of ramp 1*

Movement status of ramp at doorway 1, counting from front to back on the vehicle.

Bit States:

00 ramp not being moved
01 ramp being moved
10 error
11 not available

Data Length: 2 bits

Resolution: 4 states/2 bit, 0 offset

Data Range: 0 to 3

Operational Range: same as data range

Type: Status

Supporting information:

PGN 64880

SPN 3813 *Retract Status of ramp 2*

Retract status of ramp at doorway 2, counting from front to back on the vehicle.

Bit States:

00 ramp retracted
01 ramp extended
10 error
11 not available

Data Length: 2 bits

Resolution: 4 states/2 bit, 0 offset

Data Range: 0 to 3

Operational Range: same as data range

Type: Status

Supporting information:

PGN 64880

SPN 3814 *Enable status of ramp 2*

Enable status of ramp at doorway 2, counting from front to back on the vehicle.

Bit States:

00 ramp disabled
01 ramp enabled
10 error
11 not available

Data Length: 2 bits

Resolution: 4 states/2 bit, 0 offset

Data Range: 0 to 3

Operational Range: same as data range

Type: Status

Supporting information:

PGN 64880

SPN 3815 *Movement status of ramp 2*

Movement status of ramp at doorway 2, counting from front to back on the vehicle.

Bit States:

00 ramp not being moved
01 ramp being moved
10 error
11 not available

Data Length: 2 bits

Resolution: 4 states/2 bit, 0 offset

Data Range: 0 to 3

Operational Range: same as data range

Type: Status

Supporting information:

PGN 64880

SPN 3816 *Retract Status of ramp 3*

Retract status of ramp at doorway 3, counting from front to back on the vehicle.

Bit States:

00 ramp retracted
01 ramp extended
10 error
11 not available

Data Length: 2 bits

Resolution: 4 states/2 bit, 0 offset

Data Range: 0 to 3

Operational Range: same as data range

Type: Status

Supporting information:

PGN 64880

SPN 3817 *Enable status of ramp 3*

Enable status of ramp at doorway 3, counting from front to back on the vehicle.

Bit States:

00 ramp disabled
01 ramp enabled
10 error
11 not available

Data Length: 2 bits

Resolution: 4 states/2 bit, 0 offset

Data Range: 0 to 3

Operational Range: same as data range

Type: Status

Supporting information:

PGN 64880

SPN 3818 *Movement status of ramp 3*

Movement status of ramp at doorway 3, counting from front to back on the vehicle.

Bit States:

00 ramp not being moved
01 ramp being moved
10 error
11 not available

Data Length: 2 bits
Resolution: 4 states/2 bit, 0 offset
Data Range: 0 to 3 Operational Range: same as data range
Type: Status
Supporting information:
PGN 64880

SPN 3819 *Front axle group engagement status*

Front axle group engagement status

00 front axle group disengaged
01 front axle group engaged
10 error
11 not available

Data Length: 2 bits
Resolution: 4 states/2 bit, 0 offset
Data Range: 0 to 3 Operational Range: same as data range
Type: Status
Supporting information:
PGN 61446

SPN 3820 *Rear axle group engagement status*

Rear axle group engagement status

00 rear axle group disengaged
01 rear axle group engaged
10 error
11 not available

Data Length: 2 bits
Resolution: 4 states/2 bit, 0 offset
Data Range: 0 to 3 Operational Range: same as data range
Type: Status
Supporting information:
PGN 61446

SPN 3821 Engine Exhaust Gas Recirculation (EGR) Valve 2 Control

Desired percentage of maximum Exhaust Gas Recirculation (EGR) valve opening for valve 2. 0% means valve is closed. 100% means maximum valve opening (full gas flow).

Data Length: 2 bytes
Resolution: 0.0025 %/bit, 0 offset
Data Range: 0 to 160.6375 % Operational Range: same as data range
Type: Status
Supporting information:
PGN 64879

SPN 3822 Engine Exhaust Gas Recirculation Valve 2 Position

The position of the second exhaust gas recirculation valve expressed as a percentage of full travel. Zero percent means the valve is closed and no exhaust gas is flowing into the intake air stream. One hundred percent means the valve is fully opened.

Data Length: 2 bytes
Resolution: 0.0025 %/bit, 0 offset
Data Range: 0 to 160.6375 % Operational Range: same as data range
Type: Measured
Supporting information:
PGN 64916

SPN 3823 Transmission Torque Converter Oil Outlet Temperature

Temperature of transmission torque converter outlet oil.

Data Length: 2 bytes
Resolution: 0.03125 deg C/bit, -273 deg C offset
Data Range: -273 to 1735 deg C Operational Range: same as data range
Type: Measured
Supporting information:
PGN 64917

SPN 3826 Average Catalyst Reagent Consumption

Measured use of reagent by a Selective Catalytic Reduction system for exhaust emission control, averaged over the previous 15 hours of engine operation.

Used to determine whether the SCR system is using an appropriate amount of reagent, by comparing with the Commanded Reagent Consumption parameter (SPN 3828)

Data Length: 2 bytes
Resolution: 0.05 L/h per bit, 0 offset
Data Range: 0 to 3,212.75 L/h Operational Range: same as data range
Type: Measured
Supporting information:
PGN 64878

SPN 3828 Commanded Catalyst Reagent Consumption

This parameter transmits the amount of reagent that the emissions control system has requested to be used, averaged over the past 15 hours of engine operation.

Used to determine whether the SCR system is using an appropriate amount of reagent, by comparing with the Average Reagent Consumption parameter (SPN 3826).

Data Length: 2 bytes
Resolution: 0.05 L/h per bit, 0 offset
Data Range: 0 to 3,212.75 L/h Operational Range: same as data range
Type: Status
Supporting information:
PGN 64878

SPN 3830 Aftertreatment 1 Secondary Air Differential Pressure

Indicates the secondary air differential pressure for aftertreatment 1. Secondary air is air provided to the exhaust system (per SAE J2403).

Data Length: 2 bytes
Resolution: 1/128 kPa/bit, -250 kPa offset
Data Range: -250 kPa TO 251.99 kPa Operational Range: same as data range
Type: Measured
Supporting information:
PGN 64877

SPN 3831 Aftertreatment 1 Secondary Air Temperature

Indicates the secondary air temperature for aftertreatment 1. Secondary air is air provided to the exhaust system (per SAE J2403).

Data Length: 2 bytes
Resolution: 0.03125 deg C/bit, -273 deg C offset
Data Range: -273 to 1735 deg C Operational Range: same as data range
Type: Measured
Supporting information:
PGN 64877

SPN 3832 Aftertreatment 1 Secondary Air Mass Flow

Indicates the secondary air mass flow for aftertreatment 1. Secondary air is the air provided to the exhaust system (per SAE J2403).

Data Length: 2 bytes
Resolution: 0.2 kg/h per bit, 0 offset
Data Range: 0 to 12851 kg/h per bit Operational Range: same as data range
Type: Measured
Supporting information:
PGN 64877

SPN 3833 *Aftertreatment 2 Secondary Air Differential Pressure*

Indicates the secondary air differential pressure for aftertreatment 2. Secondary air is air provided to the exhaust system (per SAE J2403).

Data Length: 2 bytes
Resolution: 1/128 kPa/bit, -250 kPa offset
Data Range: -250 kPa TO 251.99 kPa Operational Range: same as data range
Type: Measured
Supporting information:
PGN 64876

SPN 3834 *Aftertreatment 2 Secondary Air Temperature*

Indicates the secondary air temperature for aftertreatment 2. Secondary air is air provided to the exhaust system (per SAE J2403).

Data Length: 2 bytes
Resolution: 0.03125 deg C/bit, -273 deg C offset
Data Range: -273 to 1735 deg C Operational Range: same as data range
Type: Measured
Supporting information:
PGN 64876

SPN 3835 *Aftertreatment 2 Secondary Air Mass Flow*

Indicates the secondary air mass flow for aftertreatment 2. Secondary air is the air provided to the exhaust system (per SAE J2403).

Data Length: 2 bytes
Resolution: 0.2 kg/h per bit, 0 offset
Data Range: 0 to 12851 kg/h per bit Operational Range: same as data range
Type: Measured
Supporting information:
PGN 64876

SPN 3837 *Aftertreatment 1 Secondary Air Pressure*

Pressure of the secondary air for aftertreatment 1. Secondary air is air provided to the exhaust system (per SAE J2403).

Data Length: 2 bytes
Resolution: 0.1 kPa/bit, 0 offset
Data Range: 0 to 6,425.5 kPa Operational Range: same as data range
Type: Measured
Supporting information:
PGN 64877

SPN 3838 *Aftertreatment 2 Secondary Air Pressure*

Pressure of the secondary air for aftertreatment 2. Secondary air is air provided to the exhaust system (per SAE J2403).

Data Length: 2 bytes

Resolution: 0.1 kPa/bit, 0 offset

Data Range: 0 to 6,425.5 kPa Operational Range: same as data range

Type: Measured

Supporting information:

PGN 64876

SPN 3839 *Brake Temperature Warning*

This parameter indicates if the temperature in the service brakes exceeds a certain value. It can be used for a warning information for the driver. The temperature warning value is vehicle manufacturer specific.

00 Not Active

01 Active

10 Reserved

11 not available

Data Length: 2 bits

Resolution: 4 states/2 bit, 0 offset

Data Range: 0 to 3 Operational Range: same as data range

Type: Status

Supporting information:

PGN 64964

SPN 3840 *Auxiliary I/O #17*

Identifies the current status of auxiliary input/output functions that are configured uniquely per application.

00 - Auxiliary channel off

01 - Auxiliary channel on

10 - Error Indicator or Not Used , depending on application

11 - Not Available or Take No Action, depending on application

Data Length: 2 bits

Resolution: 4 states/2 bit, 0 offset

Data Range: 0 to 3 Operational Range: same as data range

Type: Dependent upon Application

Supporting information:

PGN 42752

SPN 3841 Auxiliary I/O #18

Identifies the current status of auxiliary input/output functions that are configured uniquely per application.

00 - Auxiliary channel off
01 - Auxiliary channel on
10 - Error Indicator or Not Used , depending on application
11 - Not Available or Take No Action, depending on application

Data Length: 2 bits
Resolution: 4 states/2 bit, 0 offset
Data Range: 0 to 3 Operational Range: same as data range
Type: Dependent upon Application
Supporting information:
PGN 42752

SPN 3842 Auxiliary I/O #19

Identifies the current status of auxiliary input/output functions that are configured uniquely per application.

00 - Auxiliary channel off
01 - Auxiliary channel on
10 - Error Indicator or Not Used , depending on application
11 - Not Available or Take No Action, depending on application

Data Length: 2 bits
Resolution: 4 states/2 bit, 0 offset
Data Range: 0 to 3 Operational Range: same as data range
Type: Dependent upon Application
Supporting information:
PGN 42752

SPN 3843 Auxiliary I/O #20

Identifies the current status of auxiliary input/output functions that are configured uniquely per application.

00 - Auxiliary channel off
01 - Auxiliary channel on
10 - Error Indicator or Not Used , depending on application
11 - Not Available or Take No Action, depending on application

Data Length: 2 bits
Resolution: 4 states/2 bit, 0 offset
Data Range: 0 to 3 Operational Range: same as data range
Type: Dependent upon Application
Supporting information:
PGN 42752

SPN 3844 Auxiliary I/O #21

Identifies the current status of auxiliary input/output functions that are configured uniquely per application.

00 - Auxiliary channel off
01 - Auxiliary channel on
10 - Error Indicator or Not Used , depending on application
11 - Not Available or Take No Action, depending on application

Data Length: 2 bits
Resolution: 4 states/2 bit, 0 offset
Data Range: 0 to 3 Operational Range: same as data range
Type: Dependent upon Application
Supporting information:
PGN 42752

SPN 3845 Auxiliary I/O #22

Identifies the current status of auxiliary input/output functions that are configured uniquely per application.

00 - Auxiliary channel off
01 - Auxiliary channel on
10 - Error Indicator or Not Used , depending on application
11 - Not Available or Take No Action, depending on application

Data Length: 2 bits
Resolution: 4 states/2 bit, 0 offset
Data Range: 0 to 3 Operational Range: same as data range
Type: Dependent upon Application
Supporting information:
PGN 42752

SPN 3846 Auxiliary I/O #23

Identifies the current status of auxiliary input/output functions that are configured uniquely per application.

00 - Auxiliary channel off
01 - Auxiliary channel on
10 - Error Indicator or Not Used , depending on application
11 - Not Available or Take No Action, depending on application

Data Length: 2 bits
Resolution: 4 states/2 bit, 0 offset
Data Range: 0 to 3 Operational Range: same as data range
Type: Dependent upon Application
Supporting information:
PGN 42752

SPN 3847 Auxiliary I/O #24

Identifies the current status of auxiliary input/output functions that are configured uniquely per application.

00 - Auxiliary channel off
01 - Auxiliary channel on
10 - Error Indicator or Not Used , depending on application
11 - Not Available or Take No Action, depending on application

Data Length: 2 bits
Resolution: 4 states/2 bit, 0 offset
Data Range: 0 to 3 Operational Range: same as data range
Type: Dependent upon Application
Supporting information:
PGN 42752

SPN 3848 Auxiliary I/O #25

Identifies the current status of auxiliary input/output functions that are configured uniquely per application.

00 - Auxiliary channel off
01 - Auxiliary channel on
10 - Error Indicator or Not Used , depending on application
11 - Not Available or Take No Action, depending on application

Data Length: 2 bits
Resolution: 4 states/2 bit, 0 offset
Data Range: 0 to 3 Operational Range: same as data range
Type: Dependent upon Application
Supporting information:
PGN 42752

SPN 3849 Auxiliary I/O #26

Identifies the current status of auxiliary input/output functions that are configured uniquely per application.

00 - Auxiliary channel off
01 - Auxiliary channel on
10 - Error Indicator or Not Used , depending on application
11 - Not Available or Take No Action, depending on application

Data Length: 2 bits
Resolution: 4 states/2 bit, 0 offset
Data Range: 0 to 3 Operational Range: same as data range
Type: Dependent upon Application
Supporting information:
PGN 42752

SPN 3850 Auxiliary I/O #27

Identifies the current status of auxiliary input/output functions that are configured uniquely per application.

00 - Auxiliary channel off
01 - Auxiliary channel on
10 - Error Indicator or Not Used , depending on application
11 - Not Available or Take No Action, depending on application

Data Length: 2 bits
Resolution: 4 states/2 bit, 0 offset
Data Range: 0 to 3 Operational Range: same as data range
Type: Dependent upon Application
Supporting information:
PGN 42752

SPN 3851 Auxiliary I/O #28

Identifies the current status of auxiliary input/output functions that are configured uniquely per application.

00 - Auxiliary channel off
01 - Auxiliary channel on
10 - Error Indicator or Not Used , depending on application
11 - Not Available or Take No Action, depending on application

Data Length: 2 bits
Resolution: 4 states/2 bit, 0 offset
Data Range: 0 to 3 Operational Range: same as data range
Type: Dependent upon Application
Supporting information:
PGN 42752

SPN 3852 Auxiliary I/O #29

Identifies the current status of auxiliary input/output functions that are configured uniquely per application.

00 - Auxiliary channel off
01 - Auxiliary channel on
10 - Error Indicator or Not Used , depending on application
11 - Not Available or Take No Action, depending on application

Data Length: 2 bits
Resolution: 4 states/2 bit, 0 offset
Data Range: 0 to 3 Operational Range: same as data range
Type: Dependent upon Application
Supporting information:
PGN 42752

SPN 3853 Auxiliary I/O #30

Identifies the current status of auxiliary input/output functions that are configured uniquely per application.

00 - Auxiliary channel off
01 - Auxiliary channel on
10 - Error Indicator or Not Used , depending on application
11 - Not Available or Take No Action, depending on application

Data Length: 2 bits
Resolution: 4 states/2 bit, 0 offset
Data Range: 0 to 3 Operational Range: same as data range
Type: Dependent upon Application
Supporting information:
PGN 42752

SPN 3854 Auxiliary I/O #31

Identifies the current status of auxiliary input/output functions that are configured uniquely per application.

00 - Auxiliary channel off
01 - Auxiliary channel on
10 - Error Indicator or Not Used , depending on application
11 - Not Available or Take No Action, depending on application

Data Length: 2 bits
Resolution: 4 states/2 bit, 0 offset
Data Range: 0 to 3 Operational Range: same as data range
Type: Dependent upon Application
Supporting information:
PGN 42752

SPN 3855 Auxiliary I/O #32

Identifies the current status of auxiliary input/output functions that are configured uniquely per application.

00 - Auxiliary channel off
01 - Auxiliary channel on
10 - Error Indicator or Not Used , depending on application
11 - Not Available or Take No Action, depending on application

Data Length: 2 bits
Resolution: 4 states/2 bit, 0 offset
Data Range: 0 to 3 Operational Range: same as data range
Type: Dependent upon Application
Supporting information:
PGN 42752

SPN 3856 Auxiliary I/O #33

Identifies the current status of auxiliary input/output functions that are configured uniquely per application.

00 - Auxiliary channel off
01 - Auxiliary channel on
10 - Error Indicator or Not Used , depending on application
11 - Not Available or Take No Action, depending on application

Data Length: 2 bits
Resolution: 4 states/2 bit, 0 offset
Data Range: 0 to 3 Operational Range: same as data range
Type: Dependent upon Application
Supporting information:
PGN 42752

SPN 3857 Auxiliary I/O #34

Identifies the current status of auxiliary input/output functions that are configured uniquely per application.

00 - Auxiliary channel off
01 - Auxiliary channel on
10 - Error Indicator or Not Used , depending on application
11 - Not Available or Take No Action, depending on application

Data Length: 2 bits
Resolution: 4 states/2 bit, 0 offset
Data Range: 0 to 3 Operational Range: same as data range
Type: Dependent upon Application
Supporting information:
PGN 42752

SPN 3858 Auxiliary I/O #35

Identifies the current status of auxiliary input/output functions that are configured uniquely per application.

00 - Auxiliary channel off
01 - Auxiliary channel on
10 - Error Indicator or Not Used , depending on application
11 - Not Available or Take No Action, depending on application

Data Length: 2 bits
Resolution: 4 states/2 bit, 0 offset
Data Range: 0 to 3 Operational Range: same as data range
Type: Dependent upon Application
Supporting information:
PGN 42752

SPN 3859 Auxiliary I/O #36

Identifies the current status of auxiliary input/output functions that are configured uniquely per application.

00 - Auxiliary channel off
01 - Auxiliary channel on
10 - Error Indicator or Not Used , depending on application
11 - Not Available or Take No Action, depending on application

Data Length: 2 bits
Resolution: 4 states/2 bit, 0 offset
Data Range: 0 to 3 Operational Range: same as data range
Type: Dependent upon Application
Supporting information:
PGN 42752

SPN 3860 Auxiliary I/O #37

Identifies the current status of auxiliary input/output functions that are configured uniquely per application.

00 - Auxiliary channel off
01 - Auxiliary channel on
10 - Error Indicator or Not Used , depending on application
11 - Not Available or Take No Action, depending on application

Data Length: 2 bits
Resolution: 4 states/2 bit, 0 offset
Data Range: 0 to 3 Operational Range: same as data range
Type: Dependent upon Application
Supporting information:
PGN 42752

SPN 3861 Auxiliary I/O #38

Identifies the current status of auxiliary input/output functions that are configured uniquely per application.

00 - Auxiliary channel off
01 - Auxiliary channel on
10 - Error Indicator or Not Used , depending on application
11 - Not Available or Take No Action, depending on application

Data Length: 2 bits
Resolution: 4 states/2 bit, 0 offset
Data Range: 0 to 3 Operational Range: same as data range
Type: Dependent upon Application
Supporting information:
PGN 42752

SPN 3862 Auxiliary I/O #39

Identifies the current status of auxiliary input/output functions that are configured uniquely per application.

00 - Auxiliary channel off
01 - Auxiliary channel on
10 - Error Indicator or Not Used , depending on application
11 - Not Available or Take No Action, depending on application

Data Length: 2 bits
Resolution: 4 states/2 bit, 0 offset
Data Range: 0 to 3 Operational Range: same as data range
Type: Dependent upon Application
Supporting information:
PGN 42752

SPN 3863 Auxiliary I/O #40

Identifies the current status of auxiliary input/output functions that are configured uniquely per application.

00 - Auxiliary channel off
01 - Auxiliary channel on
10 - Error Indicator or Not Used , depending on application
11 - Not Available or Take No Action, depending on application

Data Length: 2 bits
Resolution: 4 states/2 bit, 0 offset
Data Range: 0 to 3 Operational Range: same as data range
Type: Dependent upon Application
Supporting information:
PGN 42752

SPN 3864 Auxiliary I/O #41

Identifies the current status of auxiliary input/output functions that are configured uniquely per application.

00 - Auxiliary channel off
01 - Auxiliary channel on
10 - Error Indicator or Not Used , depending on application
11 - Not Available or Take No Action, depending on application

Data Length: 2 bits
Resolution: 4 states/2 bit, 0 offset
Data Range: 0 to 3 Operational Range: same as data range
Type: Dependent upon Application
Supporting information:
PGN 42752

SPN 3865 Auxiliary I/O #42

Identifies the current status of auxiliary input/output functions that are configured uniquely per application.

00 - Auxiliary channel off
01 - Auxiliary channel on
10 - Error Indicator or Not Used , depending on application
11 - Not Available or Take No Action, depending on application

Data Length: 2 bits
Resolution: 4 states/2 bit, 0 offset
Data Range: 0 to 3 Operational Range: same as data range
Type: Dependent upon Application
Supporting information:
PGN 42752

SPN 3866 Auxiliary I/O #43

Identifies the current status of auxiliary input/output functions that are configured uniquely per application.

00 - Auxiliary channel off
01 - Auxiliary channel on
10 - Error Indicator or Not Used , depending on application
11 - Not Available or Take No Action, depending on application

Data Length: 2 bits
Resolution: 4 states/2 bit, 0 offset
Data Range: 0 to 3 Operational Range: same as data range
Type: Dependent upon Application
Supporting information:
PGN 42752

SPN 3867 Auxiliary I/O #44

Identifies the current status of auxiliary input/output functions that are configured uniquely per application.

00 - Auxiliary channel off
01 - Auxiliary channel on
10 - Error Indicator or Not Used , depending on application
11 - Not Available or Take No Action, depending on application

Data Length: 2 bits
Resolution: 4 states/2 bit, 0 offset
Data Range: 0 to 3 Operational Range: same as data range
Type: Dependent upon Application
Supporting information:
PGN 42752

SPN 3868 Auxiliary I/O #45

Identifies the current status of auxiliary input/output functions that are configured uniquely per application.

00 - Auxiliary channel off
01 - Auxiliary channel on
10 - Error Indicator or Not Used , depending on application
11 - Not Available or Take No Action, depending on application

Data Length: 2 bits
Resolution: 4 states/2 bit, 0 offset
Data Range: 0 to 3 Operational Range: same as data range
Type: Dependent upon Application
Supporting information:
PGN 42752

SPN 3869 Auxiliary I/O #46

Identifies the current status of auxiliary input/output functions that are configured uniquely per application.

00 - Auxiliary channel off
01 - Auxiliary channel on
10 - Error Indicator or Not Used , depending on application
11 - Not Available or Take No Action, depending on application

Data Length: 2 bits
Resolution: 4 states/2 bit, 0 offset
Data Range: 0 to 3 Operational Range: same as data range
Type: Dependent upon Application
Supporting information:
PGN 42752

SPN 3870 Auxiliary I/O #47

Identifies the current status of auxiliary input/output functions that are configured uniquely per application.

00 - Auxiliary channel off
01 - Auxiliary channel on
10 - Error Indicator or Not Used , depending on application
11 - Not Available or Take No Action, depending on application

Data Length: 2 bits
Resolution: 4 states/2 bit, 0 offset
Data Range: 0 to 3 Operational Range: same as data range
Type: Dependent upon Application
Supporting information:
PGN 42752

SPN 3871 Auxiliary I/O #48

Identifies the current status of auxiliary input/output functions that are configured uniquely per application.

00 - Auxiliary channel off
01 - Auxiliary channel on
10 - Error Indicator or Not Used , depending on application
11 - Not Available or Take No Action, depending on application

Data Length: 2 bits
Resolution: 4 states/2 bit, 0 offset
Data Range: 0 to 3 Operational Range: same as data range
Type: Dependent upon Application
Supporting information:
PGN 42752

SPN 3872 Auxiliary I/O #49

Identifies the current status of auxiliary input/output functions that are configured uniquely per application.

00 - Auxiliary channel off
01 - Auxiliary channel on
10 - Error Indicator or Not Used , depending on application
11 - Not Available or Take No Action, depending on application

Data Length: 2 bits
Resolution: 4 states/2 bit, 0 offset
Data Range: 0 to 3 Operational Range: same as data range
Type: Dependent upon Application
Supporting information:
PGN 42496

SPN 3873 Auxiliary I/O #50

Identifies the current status of auxiliary input/output functions that are configured uniquely per application.

00 - Auxiliary channel off
01 - Auxiliary channel on
10 - Error Indicator or Not Used , depending on application
11 - Not Available or Take No Action, depending on application

Data Length: 2 bits
Resolution: 4 states/2 bit, 0 offset
Data Range: 0 to 3 Operational Range: same as data range
Type: Dependent upon Application
Supporting information:
PGN 42496

SPN 3874 Auxiliary I/O #51

Identifies the current status of auxiliary input/output functions that are configured uniquely per application.

00 - Auxiliary channel off
01 - Auxiliary channel on
10 - Error Indicator or Not Used , depending on application
11 - Not Available or Take No Action, depending on application

Data Length: 2 bits
Resolution: 4 states/2 bit, 0 offset
Data Range: 0 to 3 Operational Range: same as data range
Type: Dependent upon Application
Supporting information:
PGN 42496

SPN 3875 Auxiliary I/O #52

Identifies the current status of auxiliary input/output functions that are configured uniquely per application.

00 - Auxiliary channel off
01 - Auxiliary channel on
10 - Error Indicator or Not Used , depending on application
11 - Not Available or Take No Action, depending on application

Data Length: 2 bits
Resolution: 4 states/2 bit, 0 offset
Data Range: 0 to 3 Operational Range: same as data range
Type: Dependent upon Application
Supporting information:
PGN 42496

SPN 3876 Auxiliary I/O #53

Identifies the current status of auxiliary input/output functions that are configured uniquely per application.

00 - Auxiliary channel off
01 - Auxiliary channel on
10 - Error Indicator or Not Used , depending on application
11 - Not Available or Take No Action, depending on application

Data Length: 2 bits
Resolution: 4 states/2 bit, 0 offset
Data Range: 0 to 3 Operational Range: same as data range
Type: Dependent upon Application
Supporting information:
PGN 42496

SPN 3877 Auxiliary I/O #54

Identifies the current status of auxiliary input/output functions that are configured uniquely per application.

00 - Auxiliary channel off
01 - Auxiliary channel on
10 - Error Indicator or Not Used , depending on application
11 - Not Available or Take No Action, depending on application

Data Length: 2 bits
Resolution: 4 states/2 bit, 0 offset
Data Range: 0 to 3 Operational Range: same as data range
Type: Dependent upon Application
Supporting information:
PGN 42496

SPN 3878 Auxiliary I/O #55

Identifies the current status of auxiliary input/output functions that are configured uniquely per application.

00 - Auxiliary channel off
01 - Auxiliary channel on
10 - Error Indicator or Not Used , depending on application
11 - Not Available or Take No Action, depending on application

Data Length: 2 bits
Resolution: 4 states/2 bit, 0 offset
Data Range: 0 to 3 Operational Range: same as data range
Type: Dependent upon Application
Supporting information:
PGN 42496

SPN 3879 Auxiliary I/O #56

Identifies the current status of auxiliary input/output functions that are configured uniquely per application.

00 - Auxiliary channel off
01 - Auxiliary channel on
10 - Error Indicator or Not Used , depending on application
11 - Not Available or Take No Action, depending on application

Data Length: 2 bits
Resolution: 4 states/2 bit, 0 offset
Data Range: 0 to 3 Operational Range: same as data range
Type: Dependent upon Application
Supporting information:
PGN 42496

SPN 3880 Auxiliary I/O #57

Identifies the current status of auxiliary input/output functions that are configured uniquely per application.

00 - Auxiliary channel off
01 - Auxiliary channel on
10 - Error Indicator or Not Used , depending on application
11 - Not Available or Take No Action, depending on application

Data Length: 2 bits
Resolution: 4 states/2 bit, 0 offset
Data Range: 0 to 3 Operational Range: same as data range
Type: Dependent upon Application
Supporting information:
PGN 42496

SPN 3881 Auxiliary I/O #58

Identifies the current status of auxiliary input/output functions that are configured uniquely per application.

00 - Auxiliary channel off
01 - Auxiliary channel on
10 - Error Indicator or Not Used , depending on application
11 - Not Available or Take No Action, depending on application

Data Length: 2 bits
Resolution: 4 states/2 bit, 0 offset
Data Range: 0 to 3 Operational Range: same as data range
Type: Dependent upon Application
Supporting information:
PGN 42496

SPN 3882 Auxiliary I/O #59

Identifies the current status of auxiliary input/output functions that are configured uniquely per application.

00 - Auxiliary channel off
01 - Auxiliary channel on
10 - Error Indicator or Not Used , depending on application
11 - Not Available or Take No Action, depending on application

Data Length: 2 bits
Resolution: 4 states/2 bit, 0 offset
Data Range: 0 to 3 Operational Range: same as data range
Type: Dependent upon Application
Supporting information:
PGN 42496

SPN 3883 Auxiliary I/O #60

Identifies the current status of auxiliary input/output functions that are configured uniquely per application.

00 - Auxiliary channel off
01 - Auxiliary channel on
10 - Error Indicator or Not Used , depending on application
11 - Not Available or Take No Action, depending on application

Data Length: 2 bits
Resolution: 4 states/2 bit, 0 offset
Data Range: 0 to 3 Operational Range: same as data range
Type: Dependent upon Application
Supporting information:
PGN 42496

SPN 3884 Auxiliary I/O #61

Identifies the current status of auxiliary input/output functions that are configured uniquely per application.

00 - Auxiliary channel off
01 - Auxiliary channel on
10 - Error Indicator or Not Used , depending on application
11 - Not Available or Take No Action, depending on application

Data Length: 2 bits
Resolution: 4 states/2 bit, 0 offset
Data Range: 0 to 3 Operational Range: same as data range
Type: Dependent upon Application
Supporting information:
PGN 42496

SPN 3885 Auxiliary I/O #62

Identifies the current status of auxiliary input/output functions that are configured uniquely per application.

00 - Auxiliary channel off
01 - Auxiliary channel on
10 - Error Indicator or Not Used , depending on application
11 - Not Available or Take No Action, depending on application

Data Length: 2 bits
Resolution: 4 states/2 bit, 0 offset
Data Range: 0 to 3 Operational Range: same as data range
Type: Dependent upon Application
Supporting information:
PGN 42496

SPN 3886 Auxiliary I/O #63

Identifies the current status of auxiliary input/output functions that are configured uniquely per application.

00 - Auxiliary channel off
01 - Auxiliary channel on
10 - Error Indicator or Not Used , depending on application
11 - Not Available or Take No Action, depending on application

Data Length: 2 bits
Resolution: 4 states/2 bit, 0 offset
Data Range: 0 to 3 Operational Range: same as data range
Type: Dependent upon Application
Supporting information:
PGN 42496

SPN 3887 Auxiliary I/O #64

Identifies the current status of auxiliary input/output functions that are configured uniquely per application.

00 - Auxiliary channel off
01 - Auxiliary channel on
10 - Error Indicator or Not Used , depending on application
11 - Not Available or Take No Action, depending on application

Data Length: 2 bits
Resolution: 4 states/2 bit, 0 offset
Data Range: 0 to 3 Operational Range: same as data range
Type: Dependent upon Application
Supporting information:
PGN 42496

SPN 3888 Auxiliary I/O #65

Identifies the current status of auxiliary input/output functions that are configured uniquely per application.

00 - Auxiliary channel off
01 - Auxiliary channel on
10 - Error Indicator or Not Used , depending on application
11 - Not Available or Take No Action, depending on application

Data Length: 2 bits
Resolution: 4 states/2 bit, 0 offset
Data Range: 0 to 3 Operational Range: same as data range
Type: Dependent upon Application
Supporting information:
PGN 42496

SPN 3889 Auxiliary I/O #66

Identifies the current status of auxiliary input/output functions that are configured uniquely per application.

00 - Auxiliary channel off
01 - Auxiliary channel on
10 - Error Indicator or Not Used , depending on application
11 - Not Available or Take No Action, depending on application

Data Length: 2 bits
Resolution: 4 states/2 bit, 0 offset
Data Range: 0 to 3 Operational Range: same as data range
Type: Dependent upon Application
Supporting information:
PGN 42496

SPN 3890 Auxiliary I/O #67

Identifies the current status of auxiliary input/output functions that are configured uniquely per application.

00 - Auxiliary channel off
01 - Auxiliary channel on
10 - Error Indicator or Not Used , depending on application
11 - Not Available or Take No Action, depending on application

Data Length: 2 bits
Resolution: 4 states/2 bit, 0 offset
Data Range: 0 to 3 Operational Range: same as data range
Type: Dependent upon Application
Supporting information:
PGN 42496

SPN 3891 Auxiliary I/O #68

Identifies the current status of auxiliary input/output functions that are configured uniquely per application.

00 - Auxiliary channel off
01 - Auxiliary channel on
10 - Error Indicator or Not Used , depending on application
11 - Not Available or Take No Action, depending on application

Data Length: 2 bits
Resolution: 4 states/2 bit, 0 offset
Data Range: 0 to 3 Operational Range: same as data range
Type: Dependent upon Application
Supporting information:
PGN 42496

SPN 3892 Auxiliary I/O #69

Identifies the current status of auxiliary input/output functions that are configured uniquely per application.

00 - Auxiliary channel off
01 - Auxiliary channel on
10 - Error Indicator or Not Used , depending on application
11 - Not Available or Take No Action, depending on application

Data Length: 2 bits
Resolution: 4 states/2 bit, 0 offset
Data Range: 0 to 3 Operational Range: same as data range
Type: Dependent upon Application
Supporting information:
PGN 42496

SPN 3893 Auxiliary I/O #70

Identifies the current status of auxiliary input/output functions that are configured uniquely per application.

00 - Auxiliary channel off
01 - Auxiliary channel on
10 - Error Indicator or Not Used , depending on application
11 - Not Available or Take No Action, depending on application

Data Length: 2 bits
Resolution: 4 states/2 bit, 0 offset
Data Range: 0 to 3 Operational Range: same as data range
Type: Dependent upon Application
Supporting information:
PGN 42496

SPN 3894 Auxiliary I/O #71

Identifies the current status of auxiliary input/output functions that are configured uniquely per application.

00 - Auxiliary channel off
01 - Auxiliary channel on
10 - Error Indicator or Not Used , depending on application
11 - Not Available or Take No Action, depending on application

Data Length: 2 bits
Resolution: 4 states/2 bit, 0 offset
Data Range: 0 to 3 Operational Range: same as data range
Type: Dependent upon Application
Supporting information:
PGN 42496

SPN 3895 Auxiliary I/O #72

Identifies the current status of auxiliary input/output functions that are configured uniquely per application.

00 - Auxiliary channel off
01 - Auxiliary channel on
10 - Error Indicator or Not Used , depending on application
11 - Not Available or Take No Action, depending on application

Data Length: 2 bits
Resolution: 4 states/2 bit, 0 offset
Data Range: 0 to 3 Operational Range: same as data range
Type: Dependent upon Application
Supporting information:
PGN 42496

SPN 3896 Auxiliary I/O #73

Identifies the current status of auxiliary input/output functions that are configured uniquely per application.

00 - Auxiliary channel off
01 - Auxiliary channel on
10 - Error Indicator or Not Used , depending on application
11 - Not Available or Take No Action, depending on application

Data Length: 2 bits
Resolution: 4 states/2 bit, 0 offset
Data Range: 0 to 3 Operational Range: same as data range
Type: Dependent upon Application
Supporting information:
PGN 42496

SPN 3897 Auxiliary I/O #74

Identifies the current status of auxiliary input/output functions that are configured uniquely per application.

00 - Auxiliary channel off
01 - Auxiliary channel on
10 - Error Indicator or Not Used , depending on application
11 - Not Available or Take No Action, depending on application

Data Length: 2 bits
Resolution: 4 states/2 bit, 0 offset
Data Range: 0 to 3 Operational Range: same as data range
Type: Dependent upon Application
Supporting information:
PGN 42496

SPN 3898 Auxiliary I/O #75

Identifies the current status of auxiliary input/output functions that are configured uniquely per application.

00 - Auxiliary channel off
01 - Auxiliary channel on
10 - Error Indicator or Not Used , depending on application
11 - Not Available or Take No Action, depending on application

Data Length: 2 bits
Resolution: 4 states/2 bit, 0 offset
Data Range: 0 to 3 Operational Range: same as data range
Type: Dependent upon Application
Supporting information:
PGN 42496

SPN 3899 Auxiliary I/O #76

Identifies the current status of auxiliary input/output functions that are configured uniquely per application.

00 - Auxiliary channel off
01 - Auxiliary channel on
10 - Error Indicator or Not Used , depending on application
11 - Not Available or Take No Action, depending on application

Data Length: 2 bits
Resolution: 4 states/2 bit, 0 offset
Data Range: 0 to 3 Operational Range: same as data range
Type: Dependent upon Application
Supporting information:
PGN 42496

SPN 3900 Auxiliary I/O #77

Identifies the current status of auxiliary input/output functions that are configured uniquely per application.

00 - Auxiliary channel off
01 - Auxiliary channel on
10 - Error Indicator or Not Used , depending on application
11 - Not Available or Take No Action, depending on application

Data Length: 2 bits
Resolution: 4 states/2 bit, 0 offset
Data Range: 0 to 3 Operational Range: same as data range
Type: Dependent upon Application
Supporting information:
PGN 42496

SPN 3904 Auxiliary I/O #81

Identifies the current status of auxiliary input/output functions that are configured uniquely per application.

00 - Auxiliary channel off
01 - Auxiliary channel on
10 - Error Indicator or Not Used , depending on application
11 - Not Available or Take No Action, depending on application

Data Length: 2 bits
Resolution: 4 states/2 bit, 0 offset
Data Range: 0 to 3 Operational Range: same as data range
Type: Dependent upon Application
Supporting information:
PGN 42240

SPN 3905 Auxiliary I/O #82

Identifies the current status of auxiliary input/output functions that are configured uniquely per application.

00 - Auxiliary channel off
01 - Auxiliary channel on
10 - Error Indicator or Not Used , depending on application
11 - Not Available or Take No Action, depending on application

Data Length: 2 bits
Resolution: 4 states/2 bit, 0 offset
Data Range: 0 to 3 Operational Range: same as data range
Type: Dependent upon Application
Supporting information:
PGN 42240

SPN 3906 Auxiliary I/O #83

Identifies the current status of auxiliary input/output functions that are configured uniquely per application.

00 - Auxiliary channel off
01 - Auxiliary channel on
10 - Error Indicator or Not Used , depending on application
11 - Not Available or Take No Action, depending on application

Data Length: 2 bits
Resolution: 4 states/2 bit, 0 offset
Data Range: 0 to 3 Operational Range: same as data range
Type: Dependent upon Application
Supporting information:
PGN 42240

SPN 3907 Auxiliary I/O #84

Identifies the current status of auxiliary input/output functions that are configured uniquely per application.

00 - Auxiliary channel off
01 - Auxiliary channel on
10 - Error Indicator or Not Used , depending on application
11 - Not Available or Take No Action, depending on application

Data Length: 2 bits
Resolution: 4 states/2 bit, 0 offset
Data Range: 0 to 3 Operational Range: same as data range
Type: Dependent upon Application
Supporting information:
PGN 42240

SPN 3908 Auxiliary I/O #85

Identifies the current status of auxiliary input/output functions that are configured uniquely per application.

00 - Auxiliary channel off
01 - Auxiliary channel on
10 - Error Indicator or Not Used , depending on application
11 - Not Available or Take No Action, depending on application

Data Length: 2 bits
Resolution: 4 states/2 bit, 0 offset
Data Range: 0 to 3 Operational Range: same as data range
Type: Dependent upon Application
Supporting information:
PGN 42240

SPN 3909 Auxiliary I/O #86

Identifies the current status of auxiliary input/output functions that are configured uniquely per application.

00 - Auxiliary channel off
01 - Auxiliary channel on
10 - Error Indicator or Not Used , depending on application
11 - Not Available or Take No Action, depending on application

Data Length: 2 bits
Resolution: 4 states/2 bit, 0 offset
Data Range: 0 to 3 Operational Range: same as data range
Type: Dependent upon Application
Supporting information:
PGN 42240

SPN 3910 Auxiliary I/O #87

Identifies the current status of auxiliary input/output functions that are configured uniquely per application.

00 - Auxiliary channel off
01 - Auxiliary channel on
10 - Error Indicator or Not Used , depending on application
11 - Not Available or Take No Action, depending on application

Data Length: 2 bits
Resolution: 4 states/2 bit, 0 offset
Data Range: 0 to 3 Operational Range: same as data range
Type: Dependent upon Application
Supporting information:
PGN 42240

SPN 3911 Auxiliary I/O #88

Identifies the current status of auxiliary input/output functions that are configured uniquely per application.

00 - Auxiliary channel off
01 - Auxiliary channel on
10 - Error Indicator or Not Used , depending on application
11 - Not Available or Take No Action, depending on application

Data Length: 2 bits
Resolution: 4 states/2 bit, 0 offset
Data Range: 0 to 3 Operational Range: same as data range
Type: Dependent upon Application
Supporting information:
PGN 42240

SPN 3912 Auxiliary I/O #89

Identifies the current status of auxiliary input/output functions that are configured uniquely per application.

00 - Auxiliary channel off
01 - Auxiliary channel on
10 - Error Indicator or Not Used , depending on application
11 - Not Available or Take No Action, depending on application

Data Length: 2 bits
Resolution: 4 states/2 bit, 0 offset
Data Range: 0 to 3 Operational Range: same as data range
Type: Dependent upon Application
Supporting information:
PGN 42240

SPN 3913 Auxiliary I/O #90

Identifies the current status of auxiliary input/output functions that are configured uniquely per application.

00 - Auxiliary channel off
01 - Auxiliary channel on
10 - Error Indicator or Not Used , depending on application
11 - Not Available or Take No Action, depending on application

Data Length: 2 bits
Resolution: 4 states/2 bit, 0 offset
Data Range: 0 to 3 Operational Range: same as data range
Type: Dependent upon Application
Supporting information:
PGN 42240

SPN 3914 Auxiliary I/O #91

Identifies the current status of auxiliary input/output functions that are configured uniquely per application.

00 - Auxiliary channel off
01 - Auxiliary channel on
10 - Error Indicator or Not Used , depending on application
11 - Not Available or Take No Action, depending on application

Data Length: 2 bits
Resolution: 4 states/2 bit, 0 offset
Data Range: 0 to 3 Operational Range: same as data range
Type: Dependent upon Application
Supporting information:
PGN 42240

SPN 3915 Auxiliary I/O #92

Identifies the current status of auxiliary input/output functions that are configured uniquely per application.

00 - Auxiliary channel off
01 - Auxiliary channel on
10 - Error Indicator or Not Used , depending on application
11 - Not Available or Take No Action, depending on application

Data Length: 2 bits
Resolution: 4 states/2 bit, 0 offset
Data Range: 0 to 3 Operational Range: same as data range
Type: Dependent upon Application
Supporting information:
PGN 42240

SPN 3916 Auxiliary I/O #93

Identifies the current status of auxiliary input/output functions that are configured uniquely per application.

00 - Auxiliary channel off
01 - Auxiliary channel on
10 - Error Indicator or Not Used , depending on application
11 - Not Available or Take No Action, depending on application

Data Length: 2 bits
Resolution: 4 states/2 bit, 0 offset
Data Range: 0 to 3 Operational Range: same as data range
Type: Dependent upon Application
Supporting information:
PGN 42240

SPN 3917 Auxiliary I/O #94

Identifies the current status of auxiliary input/output functions that are configured uniquely per application.

00 - Auxiliary channel off
01 - Auxiliary channel on
10 - Error Indicator or Not Used , depending on application
11 - Not Available or Take No Action, depending on application

Data Length: 2 bits
Resolution: 4 states/2 bit, 0 offset
Data Range: 0 to 3 Operational Range: same as data range
Type: Dependent upon Application
Supporting information:
PGN 42240

SPN 3918 Auxiliary I/O #95

Identifies the current status of auxiliary input/output functions that are configured uniquely per application.

00 - Auxiliary channel off
01 - Auxiliary channel on
10 - Error Indicator or Not Used , depending on application
11 - Not Available or Take No Action, depending on application

Data Length: 2 bits
Resolution: 4 states/2 bit, 0 offset
Data Range: 0 to 3 Operational Range: same as data range
Type: Dependent upon Application
Supporting information:
PGN 42240

SPN 3919 Auxiliary I/O #96

Identifies the current status of auxiliary input/output functions that are configured uniquely per application.

00 - Auxiliary channel off
01 - Auxiliary channel on
10 - Error Indicator or Not Used , depending on application
11 - Not Available or Take No Action, depending on application

Data Length: 2 bits
Resolution: 4 states/2 bit, 0 offset
Data Range: 0 to 3 Operational Range: same as data range
Type: Dependent upon Application
Supporting information:
PGN 42240

SPN 3920 Auxiliary I/O #97

Identifies the current status of auxiliary input/output functions that are configured uniquely per application.

00 - Auxiliary channel off
01 - Auxiliary channel on
10 - Error Indicator or Not Used , depending on application
11 - Not Available or Take No Action, depending on application

Data Length: 2 bits
Resolution: 4 states/2 bit, 0 offset
Data Range: 0 to 3 Operational Range: same as data range
Type: Dependent upon Application
Supporting information:
PGN 42240

SPN 3921 Auxiliary I/O #98

Identifies the current status of auxiliary input/output functions that are configured uniquely per application.

00 - Auxiliary channel off
01 - Auxiliary channel on
10 - Error Indicator or Not Used , depending on application
11 - Not Available or Take No Action, depending on application

Data Length: 2 bits
Resolution: 4 states/2 bit, 0 offset
Data Range: 0 to 3 Operational Range: same as data range
Type: Dependent upon Application
Supporting information:
PGN 42240

SPN 3922 Auxiliary I/O #99

Identifies the current status of auxiliary input/output functions that are configured uniquely per application.

00 - Auxiliary channel off
01 - Auxiliary channel on
10 - Error Indicator or Not Used , depending on application
11 - Not Available or Take No Action, depending on application

Data Length: 2 bits
Resolution: 4 states/2 bit, 0 offset
Data Range: 0 to 3 Operational Range: same as data range
Type: Dependent upon Application
Supporting information:
PGN 42240

SPN 3923 Auxiliary I/O #100

Identifies the current status of auxiliary input/output functions that are configured uniquely per application.

00 - Auxiliary channel off
01 - Auxiliary channel on
10 - Error Indicator or Not Used , depending on application
11 - Not Available or Take No Action, depending on application

Data Length: 2 bits
Resolution: 4 states/2 bit, 0 offset
Data Range: 0 to 3 Operational Range: same as data range
Type: Dependent upon Application
Supporting information:
PGN 42240

SPN 3924 Auxiliary I/O #101

Identifies the current status of auxiliary input/output functions that are configured uniquely per application.

00 - Auxiliary channel off
01 - Auxiliary channel on
10 - Error Indicator or Not Used , depending on application
11 - Not Available or Take No Action, depending on application

Data Length: 2 bits
Resolution: 4 states/2 bit, 0 offset
Data Range: 0 to 3 Operational Range: same as data range
Type: Dependent upon Application
Supporting information:
PGN 42240

SPN 3925 Auxiliary I/O #102

Identifies the current status of auxiliary input/output functions that are configured uniquely per application.

00 - Auxiliary channel off
01 - Auxiliary channel on
10 - Error Indicator or Not Used , depending on application
11 - Not Available or Take No Action, depending on application

Data Length: 2 bits
Resolution: 4 states/2 bit, 0 offset
Data Range: 0 to 3 Operational Range: same as data range
Type: Dependent upon Application
Supporting information:
PGN 42240

SPN 3926 Auxiliary I/O #103

Identifies the current status of auxiliary input/output functions that are configured uniquely per application.

00 - Auxiliary channel off
01 - Auxiliary channel on
10 - Error Indicator or Not Used , depending on application
11 - Not Available or Take No Action, depending on application

Data Length: 2 bits
Resolution: 4 states/2 bit, 0 offset
Data Range: 0 to 3 Operational Range: same as data range
Type: Dependent upon Application
Supporting information:
PGN 42240

SPN 3927 Auxiliary I/O #104

Identifies the current status of auxiliary input/output functions that are configured uniquely per application.

00 - Auxiliary channel off
01 - Auxiliary channel on
10 - Error Indicator or Not Used , depending on application
11 - Not Available or Take No Action, depending on application

Data Length: 2 bits
Resolution: 4 states/2 bit, 0 offset
Data Range: 0 to 3 Operational Range: same as data range
Type: Dependent upon Application
Supporting information:
PGN 42240

SPN 3928 Auxiliary I/O #105

Identifies the current status of auxiliary input/output functions that are configured uniquely per application.

00 - Auxiliary channel off
01 - Auxiliary channel on
10 - Error Indicator or Not Used , depending on application
11 - Not Available or Take No Action, depending on application

Data Length: 2 bits
Resolution: 4 states/2 bit, 0 offset
Data Range: 0 to 3 Operational Range: same as data range
Type: Dependent upon Application
Supporting information:
PGN 42240

SPN 3929 Auxiliary I/O #106

Identifies the current status of auxiliary input/output functions that are configured uniquely per application.

00 - Auxiliary channel off
01 - Auxiliary channel on
10 - Error Indicator or Not Used , depending on application
11 - Not Available or Take No Action, depending on application

Data Length: 2 bits
Resolution: 4 states/2 bit, 0 offset
Data Range: 0 to 3 Operational Range: same as data range
Type: Dependent upon Application
Supporting information:
PGN 42240

SPN 3930 Auxiliary I/O #107

Identifies the current status of auxiliary input/output functions that are configured uniquely per application.

00 - Auxiliary channel off
01 - Auxiliary channel on
10 - Error Indicator or Not Used , depending on application
11 - Not Available or Take No Action, depending on application

Data Length: 2 bits
Resolution: 4 states/2 bit, 0 offset
Data Range: 0 to 3 Operational Range: same as data range
Type: Dependent upon Application
Supporting information:
PGN 42240

SPN 3931 Auxiliary I/O #108

Identifies the current status of auxiliary input/output functions that are configured uniquely per application.

00 - Auxiliary channel off
01 - Auxiliary channel on
10 - Error Indicator or Not Used , depending on application
11 - Not Available or Take No Action, depending on application

Data Length: 2 bits
Resolution: 4 states/2 bit, 0 offset
Data Range: 0 to 3 Operational Range: same as data range
Type: Dependent upon Application
Supporting information:
PGN 42240

SPN 3932 Auxiliary I/O #109

Identifies the current status of auxiliary input/output functions that are configured uniquely per application.

00 - Auxiliary channel off
01 - Auxiliary channel on
10 - Error Indicator or Not Used , depending on application
11 - Not Available or Take No Action, depending on application

Data Length: 2 bits
Resolution: 4 states/2 bit, 0 offset
Data Range: 0 to 3 Operational Range: same as data range
Type: Dependent upon Application
Supporting information:
PGN 42240

SPN 3933 Auxiliary I/O #110

Identifies the current status of auxiliary input/output functions that are configured uniquely per application.

00 - Auxiliary channel off
01 - Auxiliary channel on
10 - Error Indicator or Not Used , depending on application
11 - Not Available or Take No Action, depending on application

Data Length: 2 bits
Resolution: 4 states/2 bit, 0 offset
Data Range: 0 to 3 Operational Range: same as data range
Type: Dependent upon Application
Supporting information:
PGN 42240

SPN 3934 Auxiliary I/O #111

Identifies the current status of auxiliary input/output functions that are configured uniquely per application.

00 - Auxiliary channel off
01 - Auxiliary channel on
10 - Error Indicator or Not Used , depending on application
11 - Not Available or Take No Action, depending on application

Data Length: 2 bits
Resolution: 4 states/2 bit, 0 offset
Data Range: 0 to 3 Operational Range: same as data range
Type: Dependent upon Application
Supporting information:
PGN 42240

SPN 3935 Auxiliary I/O #112

Identifies the current status of auxiliary input/output functions that are configured uniquely per application.

00 - Auxiliary channel off
01 - Auxiliary channel on
10 - Error Indicator or Not Used , depending on application
11 - Not Available or Take No Action, depending on application

Data Length: 2 bits
Resolution: 4 states/2 bit, 0 offset
Data Range: 0 to 3 Operational Range: same as data range
Type: Dependent upon Application
Supporting information:
PGN 42240

SPN 3939 Enable Switch - PTO Engine Flywheel

Status of the PTO Engine Flywheel enable switch

00 Enable switch off – PTO operation not desired
01 Enable switch on – PTO operation desired
10 Error
11 Not available

Data Length: 2 bits
Resolution: 4 states/2 bit, 0 offset
Data Range: 0 to 3 Operational Range: same as data range
Type: Status
Supporting information:
PGN 64932

SPN 3946 Engagement Consent - PTO Engine Accessory Drive 2

Engagement Consent status for the PTO engine accessory drive 2

00 Consent not given – PTO drive may not be engaged
 01 Consent given – PTO drive may be engaged
 10 Error
 11 Not available

Data Length: 2 bits
 Resolution: 4 states/2 bit, 0 offset
 Data Range: 0 to 3 Operational Range: same as data range
 Type: Status
 Supporting information:
 PGN 64932

SPN 3947 Engagement Status - PTO Engine Accessory Drive 2

Engagement status of the PTO engine accessory drive 2

00 Drive not engaged
 01 Drive engaged
 10 Error
 11 Not available

Data Length: 2 bits
 Resolution: 4 states/2 bit, 0 offset
 Data Range: 0 to 3 Operational Range: same as data range
 Type: Status
 Supporting information:
 PGN 64932

SPN 3948 At least one PTO engaged

Indicates that at least one PTO is engaged

00 No PTO drive is engaged
 01 At least one PTO drive is engaged
 10 Error
 11 Not available

Note: This parameter should only be sent by the controller that has knowledge of all PTO drives on the vehicle (e.g. the FMS gateway). Individual PTO drive controllers should broadcast this parameter as "not available".

Data Length: 2 bits
 Resolution: 4 states/2 bit, 0 offset
 Data Range: 0 to 3 Operational Range: same as data range
 Type: Status
 Supporting information:
 PGN 64932

SPN 4059 Steer Axle Group Weight Available

Indicates the availability of the steer axle group for purposes of weight measurement

00 = Steer axle group not present
01 = Steer axle group present
10 = Reserved
11 = Not available / not applicable

Data Length: 2 bits

Resolution: 4 states/2 bit, 0 offset

Data Range: 0 to 3

Operational Range: same as data range

Type: Status

Supporting information:

PGN 64875

SPN 4060 Lift Axle Group Weight Available

Indicates the availability of the lift axle group for purposes of weight measurement

00 = Lift axle group not present
01 = Lift axle group present
10 = Reserved
11 = Not available / not applicable

Data Length: 2 bits

Resolution: 4 states/2 bit, 0 offset

Data Range: 0 to 3

Operational Range: same as data range

Type: Status

Supporting information:

PGN 64875

SPN 4061 Drive Axle Group Weight Available

Indicates the availability of the drive axle group for purposes of weight measurement

00 = Drive axle group not present
01 = Drive axle group present
10 = Reserved
11 = Not available / not applicable

Data Length: 2 bits

Resolution: 4 states/2 bit, 0 offset

Data Range: 0 to 3

Operational Range: same as data range

Type: Status

Supporting information:

PGN 64875

SPN 4062 Tag Axle Group Weight Available

Indicates the availability of the tag axle group for purposes of weight measurement

00 = Tag axle group not present
01 = Tag axle group present
10 = Reserved
11 = Not available / not applicable

Data Length: 2 bits
Resolution: 4 states/2 bit, 0 offset
Data Range: 0 to 3 Operational Range: same as data range
Type: Status
Supporting information:
PGN 64875

SPN 4063 Additional Tractor Axle Group Weight Available

Indicates the availability of the additional tractor axle group for purposes of weight measurement

00 = Additional tractor axle group not present
01 = Additional tractor axle group present
10 = Reserved
11 = Not available / not applicable

Data Length: 2 bits
Resolution: 4 states/2 bit, 0 offset
Data Range: 0 to 3 Operational Range: same as data range
Type: Status
Supporting information:
PGN 64875

SPN 4064 Trailer A Axle Group Weight Available

Indicates the availability of the trailer A axle group for purposes of weight measurement

00 = Trailer A axle group not present
01 = Trailer A axle group present
10 = Reserved
11 = Not available / not applicable

Data Length: 2 bits
Resolution: 4 states/2 bit, 0 offset
Data Range: 0 to 3 Operational Range: same as data range
Type: Status
Supporting information:
PGN 64875

SPN 4065 Trailer B Axle Group Weight Available

Indicates the availability of the trailer B axle group for purposes of weight measurement

00 = Trailer B axle group not present
01 = Trailer B axle group present
10 = Reserved
11 = Not available / not applicable

Data Length: 2 bits

Resolution: 4 states/2 bit, 0 offset

Data Range: 0 to 3

Operational Range: same as data range

Type: Status

Supporting information:

PGN 64875

SPN 4066 Trailer C Axle Group Weight Available

Indicates the availability of the trailer C axle group for purposes of weight measurement

00 = Trailer C axle group not present
01 = Trailer C axle group present
10 = Reserved
11 = Not available / not applicable

Data Length: 2 bits

Resolution: 4 states/2 bit, 0 offset

Data Range: 0 to 3

Operational Range: same as data range

Type: Status

Supporting information:

PGN 64875

SPN 4067 Trailer D Axle Group Weight Available

Indicates the availability of the trailer D axle group for purposes of weight measurement

00 = Trailer D axle group not present
01 = Trailer D axle group present
10 = Reserved
11 = Not available / not applicable

Data Length: 2 bits

Resolution: 4 states/2 bit, 0 offset

Data Range: 0 to 3

Operational Range: same as data range

Type: Status

Supporting information:

PGN 64875

SPN 4068 Trailer E Axle Group Weight Available

Indicates the availability of the trailer E axle group for purposes of weight measurement

00 = Trailer E axle group not present
01 = Trailer E axle group present
10 = Reserved
11 = Not available / not applicable

Data Length: 2 bits
Resolution: 4 states/2 bit, 0 offset
Data Range: 0 to 3 Operational Range: same as data range
Type: Status
Supporting information:
PGN 64875

SPN 4069 Trailer F Axle Group Weight Available

Indicates the availability of the trailer F axle group for purposes of weight measurement

00 = Trailer F axle group not present
01 = Trailer F axle group present
10 = Reserved
11 = Not available / not applicable

Data Length: 2 bits
Resolution: 4 states/2 bit, 0 offset
Data Range: 0 to 3 Operational Range: same as data range
Type: Status
Supporting information:
PGN 64875

SPN 4070 Trailer G Axle Group Weight Available

Indicates the availability of the trailer G axle group for purposes of weight measurement

00 = Trailer G axle group not present
01 = Trailer G axle group present
10 = Reserved
11 = Not available / not applicable

Data Length: 2 bits
Resolution: 4 states/2 bit, 0 offset
Data Range: 0 to 3 Operational Range: same as data range
Type: Status
Supporting information:
PGN 64875

SPN 4071 Trailer H Axle Group Weight Available

Indicates the availability of the trailer H axle group for purposes of weight measurement

00 = Trailer H axle group not present
 01 = Trailer H axle group present
 10 = Reserved
 11 = Not available / not applicable

Data Length: 2 bits
 Resolution: 4 states/2 bit, 0 offset
 Data Range: 0 to 3 Operational Range: same as data range
 Type: Status
 Supporting information:
 PGN 64875

SPN 4072 Additional Trailer Axle Group Weight Available

Indicates the availability of the additional trailer axle group for purposes of weight measurement

00 = Additional trailer axle group not present
 01 = Additional trailer axle group present
 10 = Reserved
 11 = Not available / not applicable

Data Length: 2 bits
 Resolution: 4 states/2 bit, 0 offset
 Data Range: 0 to 3 Operational Range: same as data range
 Type: Status
 Supporting information:
 PGN 64875

SPN 4073 Axle Group Location

Specific axle group used in conjunction with and when communicating the axle group weight, listed from the front of the vehicle to the rear.

0 = Reserved
 1 = Steer axle group
 2 = Lift axle group
 3 = Drive axle group
 4 = Tag axle group
 5 = Additional tractor axle group
 6 = Trailer A axle group
 7 = Trailer B axle group
 8 = Trailer C axle group
 9 = Trailer D axle group
 10 = Trailer E axle group
 11 = Trailer F axle group
 12 = Trailer G axle group
 13 = Trailer H axle group
 14 = Additional trailer axle group
 15 = Reserved

Data Length: 4 bits
 Resolution: 16 states/4 bit, 0 offset
 Data Range: 0 to 15 Operational Range: same as data range
 Type: Measured
 Supporting information:
 PGN 64874

SPN 4074 Axle Group Location

Specific axle group used in conjunction with and when communicating the axle group calibration, listed from the front of the vehicle to the rear.

0 = Reserved
 1 = Steer axle group
 2 = Lift axle group
 3 = Drive axle group
 4 = Tag axle group
 5 = Additional tractor axle group
 6 = Trailer A axle group
 7 = Trailer B axle group
 8 = Trailer C axle group
 9 = Trailer D axle group
 10 = Trailer E axle group
 11 = Trailer F axle group
 12 = Trailer G axle group
 13 = Trailer H axle group
 14 = Additional trailer axle group
 15 = Reserved

Data Length: 4 bits
 Resolution: 16 states/4 bit, 0 offset
 Data Range: 0 to 15 Operational Range: same as data range
 Type: Measured
 Supporting information:
 PGN 64873

SPN 4075 Zero Net Vehicle Weight Change

Zero Net Vehicle Weight Change command. A controller receiving this command will record the current Gross Combination Weight as the new Zero, and future requests for Net Vehicle Weight Change will be answered with the difference between the (then) current Gross Combination Weight and the recorded value.

00 - No change to Net Vehicle Weight Change
 01 - Zero Net Vehicle Weight Change
 10 - Reserved
 11 - Not available / Not applicable

Data Length: 2 bits
 Resolution: 4 states/2 bit, 0 offset
 Data Range: 0 to 3 Operational Range: same as data range
 Type: Status
 Supporting information:
 PGN 64871

SPN 4076 Engine Coolant Temperature 2

Second temperature of liquid found in the engine cooling system. See also SPN 110.

Data Length: 1 byte
 Resolution: 1 deg C/bit, -40 deg C offset
 Data Range: -40 to 210 deg C Operational Range: same as data range
 Type: Measured
 Supporting information:
 PGN 64870

SPN 4077 *Aftertreatment 1 Fuel Pressure 2*

Second fuel pressure measurement for the aftertreatment 1 system

Data Length: 2 bytes

Resolution: 0.1 kPa/bit, 0 offset

Data Range: 0 to 6,425.5 kPa Operational Range: same as data range

Type: Measured

Supporting information:

PGN 64869

SPN 4082 *Fuel Pump Primer Control*

Parameter used to activate or deactivate a priming system on the fuel transfer system. The fuel priming system is a system that purges air in the fuel lines and may assist fuel delivery to a second pump at lower speeds.

00 = Deactivate

01 = Activate

10 = Reserved

11 = Unavailable

Data Length: 2 bits

Resolution: 4 states/2 bit, 0 offset

Data Range: 0 to 3 Operational Range: same as data range

Type: Status

Supporting information:

PGN 64914

SPN 4083 *Fuel Pump Primer Status*

Parameter used to transmit the actual status of the fuel priming system. The fuel priming system is a system that purges air in the fuel lines and may assist fuel delivery to a second pump at lower speeds.

00 – Off

01 – On

10 – Error

11 – Unavailable

Data Length: 2 bits

Resolution: 4 states/2 bit, 0 offset

Data Range: 0 to 3 Operational Range: same as data range

Type: Status

Supporting information:

PGN 65130

SPN 4086 *Valve Load Sense Pressure*

The maximum of the currently measured pressures of a valve's work port A and work port B.

Data Length: 2 bytes

Resolution: 5 kPa/bit, 0 offset

Data Range: 0 to 321,275 kPa Operational Range: same as data range

Type: Measured

Supporting information:

PGN 1792

SPN 4087 Valve Pilot Pressure

Pressure of a valve's pilot supply port.

Data Length: 1 byte

Resolution: 16 kPa/bit, 0 offset

Data Range: 0 to 4000 kPa Operational Range: same as data range

Type: Measured

Supporting information:

PGN 1792

SPN 4088 Valve Assembly Load sense Pressure

The maximum pressure of a valve assembly's current collective load sense pressures where a valve assembly can consist of two or more valves.

Data Length: 2 bytes

Resolution: 5 kPa/bit, 0 offset

Data Range: 0 to 321,275 kPa Operational Range: same as data range

Type: Measured

Supporting information:

PGN 1792

SPN 4089 Valve Assembly Supply Pressure

Pressure of the hydraulic supply port to a valve assembly.

Data Length: 2 bytes

Resolution: 5 kPa/bit, 0 offset

Data Range: 0 to 321,275 kPa Operational Range: same as data range

Type: Measured

Supporting information:

PGN 1792

SPN 4097 Aftertreatment 1 Fuel Drain Actuator

Indicates whether aftertreatment 1 fuel drain actuator is on or off

00 not active

01 active

10 reserved for SAE assignment

11 not available

Data Length: 2 bits

Resolution: 4 states/2 bit, 0 offset

Data Range: 0 to 3 Operational Range: same as data range

Type: Status

Supporting information:

PGN 64929

SPN 4098 *Aftertreatment 2 Fuel Drain Actuator*

Indicates whether aftertreatment 2 fuel drain actuator is on or off

00 not active
01 active
10 reserved for SAE assignment
11 not available

Data Length: 2 bits

Resolution: 4 states/2 bit, 0 offset

Data Range: 0 to 3

Operational Range: same as data range

Type: Status

Supporting information:

PGN 64928

SPN 4099 XBR urgency

The idea of the urgency value is to adjust the endurance brake integration behavior in the EBS system according to the traffic situation.

On low urgency values (0%, e.g. downhill cruise control or preceding vehicle far ahead) the brake system shall primarily use endurance brakes to reduce lining wear.

On high urgency values (100%, e.g. vehicle close up or a vehicle cuts into the traffic line just before host vehicle) the brake system is expected to gain the demanded deceleration (acceleration) as fast as possible.

Values:

0% - Situation not critical; low retarder dynamics are tolerated. Activation of the foundation brakes after a time if retarder performance is insufficient

y % - Faster activation of foundation brakes to compensate retarder performance, linear interpolation between 0 and 100%

100% - Low retarder dynamics shall be fully compensated by the foundation brakes

Notes:

- This parameter has only an effect if XBR EBI switch is set to "10: endurance brake integration allowed"

- XBR urgency makes sense only if the XBR request(s) is (are) processed in one device like the EBS controller which also sends TSC1 to the retarder(s). Such a data flow diagram is shown in figure PGN1024_A. When the Retarder is controlled directly by the XBR transmitter XBR urgency should be set to not available.

In adaptive cruise control (ACC) operation there are situations where it is useful to have as less lining wear as possible like keeping the set speed on going downhill. It would not be useful to activate foundation brakes in such a situation except when the capabilities of the endurance brakes are not sufficient.

In other situations like emergency braking or fast reaction on a car that cut in at a short distance in front of the own vehicle a reaction as fast as possible is needed. In such cases low retarder dynamics must be compensated by the foundation brakes.

There are two different ways to integrate the endurance brakes into the adaptive cruise control.

a) the request for deceleration could be processed by the EBS system completely. This means that the EBS receives the deceleration demand and activates the friction and/or the endurance brakes accordingly. EBS is sending the TSC1 to the retarder. (see figure PGN1024_A dataflow diagram for external brake request)

b) the ACC sends XBR to the brake controller and TSC1 to the endurance brakes.

In case "a)" the ACC system does not have direct control of the endurance brakes. To adjust the endurance brakes according to the traffic situation (high or low urgency values see above) this new SPN is needed.

If the retarder performance is not sufficient (e.g. because of high retarder temperature) the foundation brakes will be added automatically. This case of not sufficient retarder performance cannot be covered by switching EBI mode from 01 (endurance brakes only) to EBI mode 10 (endurance brake integration allowed) because the actual deceleration caused by the retarder is less than the requested deceleration. A simple switching (01 to 10) would cause an uncomfortable jerk.

NOTE: This parameter is defined in European patent EP 1 386 774 B1 (see reference in section 2.1.3) and is included with permission from the patent holder. The patent holder is prepared to grant a free license to an unrestricted number of applicants on a worldwide, non-discriminatory basis to comply with this recommended practice.

Data Length: 1 byte

Resolution: 0.4 %/bit, 0 offset

Data Range: 0 to 100 %

Operational Range: same as data range

Type: Status

Supporting information:

PGN 1024

SPN 4151 (R) Engine Exhaust Gas Temperature Average

The calculated average temperature based upon all of the engine exhaust port temperatures. This is the average temperature based upon the exhaust port temperature measurements at each of the engine cylinders.

Notes:

Use SPN 173 - Engine Exhaust Gas Temperature to report the actual measured temperature of the exhaust for the entire engine, after the turbocharger.

See SPN 2433 - Engine Exhaust Gas Temperature - Right Manifold, and SPN 2434 - Engine Exhaust Gas Temperature - Left Manifold to report the actual measured temperature of the manifold for engines requiring more than one exhaust temperature measurement.

Data Length: 2 bytes
Resolution: 0.03125 deg C/bit, -273 deg C offset
Data Range: -273 to 1735 deg C Operational Range: same as data range
Type: Status
Supporting information: See Appendix D - SPN 4151
PGN 64851

SPN 4152 (R) Engine Exhaust Gas Temperature Average - Bank 2

The calculated average temperature based upon all of the Bank 2 (right bank) engine exhaust port temperatures. This is the average temperature based upon the exhaust port temperature measurements of each of the engine cylinders on the right bank before the turbocharger.

Use SPN 2433 Engine Exhaust Gas Temperature - Right Manifold to report the actual measured temperature of the manifold on the right side as seen from the flywheel end of the engine.

Data Length: 2 bytes
Resolution: 0.03125 deg C/bit, -273 deg C offset
Data Range: -273 to 1735 deg C Operational Range: same as data range
Type: Status
Supporting information: See Appendix D - SPN 4151
PGN 64851

SPN 4153 (R) Engine Exhaust Gas Temperature Average - Bank 1

The calculated average temperature based upon all of the Bank 1 (left bank) engine exhaust port temperatures. This is the average temperature based upon the exhaust port temperature measurements of each of the engine cylinders on the left bank prior to the turbocharger.

Use SPN 2434 Engine Exhaust Gas Temperature - Left Manifold to report the actual measured temperature of the manifold on the left side as seen from the flywheel end of the engine.

Data Length: 2 bytes
Resolution: 0.03125 deg C/bit, -273 deg C offset
Data Range: -273 to 1735 deg C Operational Range: same as data range
Type: Status
Supporting information: See Appendix D - SPN 4151
PGN 64851

SPN 4154 (R) Actual Engine - Percent Torque High Resolution

This parameter displays an additional torque in percent of the reference engine torque.

When the MSB is set to 1, this parameter is not available. When the MSB is set to 0, bits 1 to 3 indicate the desired torque with resolution of 0.125%/bit. Range is from 0 to 0.875% of reference torque.

The parameter is used in combination with SPN 513 Actual Engine Torque. The resulting actual engine torque will be calculated by adding these two parameters.

Additional torque representations

0000 = +0.000%

0001 = +0.125%

.

.

.

0111 = +0.875%

1000 - 1111 = not available

For example, if SPN 513 = 150 (or 25%) and this parameter is 0100, the torque would be 25.5%.

If SPN 513 = 175 (or 50%) and this parameter is 0001, the torque would be 50.125%

If SPN 513 = 175 (or 50%) and this parameter is 1111, the torque would remain 50% (no high resolution available)

Data Length: 4 bits

Resolution: 0.125%/bit, 0 offset

Data Range: 0 to 0.875%

Operational Range: same as data range

Type: Measured

Supporting information:

PGN 61444

SPN 4155 (R) Auxiliary I/O Channel #6

Identifies the current value of auxiliary input/output channels that are configured uniquely per application.

Data Length: 2 bytes

Resolution: 1 count/bit, 0 offset

Data Range: 0 to 64,255 counts

Operational Range: same as data range

Type: Dependent upon Application

Supporting information:

PGN 2048

SPN 4156 (R) Auxiliary I/O Channel #5

Identifies the current value of auxiliary input/output channels that are configured uniquely per application.

Data Length: 2 bytes

Resolution: 1 count/bit, 0 offset

Data Range: 0 to 64,255 counts

Operational Range: same as data range

Type: Dependent upon Application

Supporting information:

PGN 2048

SPN 4157 (R) Auxiliary I/O Channel #4

Identifies the current value of auxiliary input/output channels that are configured uniquely per application.

Data Length: 2 bytes

Resolution: 1 count/bit, 0 offset

Data Range: 0 to 64,255 counts Operational Range: same as data range

Type: Dependent upon Application

Supporting information:

PGN 2048

SPN 4158 (R) Auxiliary I/O Channel #3

Identifies the current value of auxiliary input/output channels that are configured uniquely per application.

Data Length: 2 bytes

Resolution: 1 count/bit, 0 offset

Data Range: 0 to 64,255 counts Operational Range: same as data range

Type: Dependent upon Application

Supporting information:

PGN 2048

SPN 4159 (R) Auxiliary I/O Channel #10

Identifies the current value of auxiliary input/output channels that are configured uniquely per application.

Data Length: 1 byte

Resolution: 1 count/bit, 0 offset

Data Range: 0 to 250 Operational Range: same as data range

Type: Dependent upon Application

Supporting information:

PGN 40192

SPN 4160 (R) Auxiliary I/O Channel #9

Identifies the current value of auxiliary input/output channels that are configured uniquely per application.

Data Length: 1 byte

Resolution: 1 count/bit, 0 offset

Data Range: 0 to 250 Operational Range: same as data range

Type: Dependent upon Application

Supporting information:

PGN 40192

SPN 4161 (R) Auxiliary I/O Channel #8

Identifies the current value of auxiliary input/output channels that are configured uniquely per application.

Data Length: 1 byte

Resolution: 1 count/bit, 0 offset

Data Range: 0 to 250 Operational Range: same as data range

Type: Dependent upon Application

Supporting information:

PGN 40192

SPN 4162 (R) Auxiliary I/O Channel #7

Identifies the current value of auxiliary input/output channels that are configured uniquely per application.

Data Length: 1 byte

Resolution: 1 count/bit, 0 offset

Data Range: 0 to 250 Operational Range: same as data range

Type: Dependent upon Application

Supporting information:

PGN 40192

SPN 4163 (R) Auxiliary I/O Channel #14

Identifies the current value of auxiliary input/output channels that are configured uniquely per application.

Data Length: 1 byte

Resolution: 1 count/bit, 0 offset

Data Range: 0 to 250 Operational Range: same as data range

Type: Dependent upon Application

Supporting information:

PGN 40192

SPN 4164 (R) Auxiliary I/O Channel #13

Identifies the current value of auxiliary input/output channels that are configured uniquely per application.

Data Length: 1 byte

Resolution: 1 count/bit, 0 offset

Data Range: 0 to 250 Operational Range: same as data range

Type: Dependent upon Application

Supporting information:

PGN 40192

SPN 4165 (R) Auxiliary I/O Channel #12

Identifies the current value of auxiliary input/output channels that are configured uniquely per application.

Data Length: 1 byte

Resolution: 1 count/bit, 0 offset

Data Range: 0 to 250 Operational Range: same as data range

Type: Dependent upon Application

Supporting information:

PGN 40192

SPN 4166 (R) Auxiliary I/O Channel #11

Identifies the current value of auxiliary input/output channels that are configured uniquely per application.

Data Length: 1 byte

Resolution: 1 count/bit, 0 offset

Data Range: 0 to 250 Operational Range: same as data range

Type: Dependent upon Application

Supporting information:

PGN 40192

SPN 4167 (R) Auxiliary I/O Channel #18

Identifies the current value of auxiliary input/output channels that are configured uniquely per application.

Data Length: 1 byte

Resolution: 1 count/bit, 0 offset

Data Range: 0 to 250 Operational Range: same as data range

Type: Dependent upon Application

Supporting information:

PGN 39936

SPN 4168 (R) Auxiliary I/O Channel #17

Identifies the current value of auxiliary input/output channels that are configured uniquely per application.

Data Length: 1 byte

Resolution: 1 count/bit, 0 offset

Data Range: 0 to 250 Operational Range: same as data range

Type: Dependent upon Application

Supporting information:

PGN 39936

SPN 4169 (R) Auxiliary I/O Channel #16

Identifies the current value of auxiliary input/output channels that are configured uniquely per application.

Data Length: 1 byte

Resolution: 1 count/bit, 0 offset

Data Range: 0 to 250 Operational Range: same as data range

Type: Dependent upon Application

Supporting information:

PGN 39936

SPN 4170 (R) Auxiliary I/O Channel #15

Identifies the current value of auxiliary input/output channels that are configured uniquely per application.

Data Length: 1 byte

Resolution: 1 count/bit, 0 offset

Data Range: 0 to 250 Operational Range: same as data range

Type: Dependent upon Application

Supporting information:

PGN 39936

SPN 4171 (R) Auxiliary I/O Channel #22

Identifies the current value of auxiliary input/output channels that are configured uniquely per application.

Data Length: 1 byte

Resolution: 1 count/bit, 0 offset

Data Range: 0 to 250 Operational Range: same as data range

Type: Dependent upon Application

Supporting information:

PGN 39936

SPN 4172 (R) Auxiliary I/O Channel #21

Identifies the current value of auxiliary input/output channels that are configured uniquely per application.

Data Length: 1 byte

Resolution: 1 count/bit, 0 offset

Data Range: 0 to 250 Operational Range: same as data range

Type: Dependent upon Application

Supporting information:

PGN 39936

SPN 4173 (R) Auxiliary I/O Channel #20

Identifies the current value of auxiliary input/output channels that are configured uniquely per application.

Data Length: 1 byte
Resolution: 1 count/bit, 0 offset
Data Range: 0 to 250 Operational Range: same as data range
Type: Dependent upon Application
Supporting information:
PGN 39936

SPN 4174 (R) Auxiliary I/O Channel #19

Identifies the current value of auxiliary input/output channels that are configured uniquely per application.

Data Length: 1 byte
Resolution: 1 count/bit, 0 offset
Data Range: 0 to 250 Operational Range: same as data range
Type: Dependent upon Application
Supporting information:
PGN 39936

SPN 4175 (R) Diesel Particulate Filter Active Regeneration Forced Status

Indicates the forced execution status of diesel particulate filter regeneration.

000 Not Active
001 Active – Forced by Switch (See SPN 3696)
010 Active – Forced by Service Tool
011 Reserved for SAE Assignment
100 Reserved for SAE Assignment
101 Reserved for SAE Assignment
110 Reserved for SAE Assignment
111 not available

This SPN indicates the forced execution status of diesel particulate filter regeneration. The SPN would be "Not Active" when the execution of diesel particulate filter regeneration has not been forced. Either of the states "Active – Forced by Switch" and "Active – Forced by Service Tool" will be active when execution of diesel particulate filter regeneration is forced, providing feedback as to which entity forced the execution of diesel particulate filter regeneration.

Data Length: 3 bits
Resolution: 8 states/3 bit, 0 offset
Data Range: 0 to 7 Operational Range: same as data range
Type: Status
Supporting information:
PGN 64892

SPN 4176 (R) Transmission Current Range Display Blank State

State signal indicating a transmission request for the display of the Transmission Current Range parameter (SPN 163) to be blanked or not blanked. The 'Transmission Current Range Display Blank State' indicator can be utilized by (but not limited to) the shift console, instrument cluster, or cab display. Definition of the cause of this state is at the discretion of the transmission manufacturer.

00=Not Blanked
01=Blanked
10=Error
11=Not Supported

Note: This is a companion of SPN 1850, that will allow the "current range" display to be blanked as needed while still retaining a valid current range broadcast in SPN 163.

Data Length: 2 bits
Resolution: 4 states/2 bit, 0 offset
Data Range: 0 to 3 Operational Range: same as data range
Type: Status
Supporting information:
PGN 65098

SPN 4177 (R) Transmission Oil Life Remaining

Signal which indicates the actual oil life remaining in percent. 100% means the transmission oil is brand new, and 0% means the transmission oil is at the end of its life.

Data Length: 1 byte
Resolution: 0.4 %/bit, 0 offset
Data Range: 0 to 100 % Operational Range: same as data range
Type: Measured
Supporting information:
PGN 64917

SPN 4178 (R) Transmission Service Indicator

Signal from transmission indicating that some aspect of the gearbox requires servicing, such as the oil, filter, clutch(es) or other component.

00 Transmission Service Indicator is off
01 Transmission Service Indicator is on continuously
10 Transmission Service Indicator is flashing
11 Not available

Data Length: 2 bits
Resolution: 4 states/2 bit, 0 offset
Data Range: 0 to 3 Operational Range: same as data range
Type: Status
Supporting information:
PGN 65098

SPN 4180 (R) Data Dictionary Manufacturer Code

The J1939 Manufacturer Code (see J1939 Table B10) associated with the manufacturer who defined the proprietary communications method. 0x7FF reserved for "Not Available"

Data Length: 11 bits
 Resolution: 2047 states/11bit, 0 offset
 Data Range: 0 to 2047 Operational Range: same as data range
 Type: Status
 Supporting information:
 PGN 39680

SPN 4181 (R) Data Dictionary Method

A manufacturer defined code to define the proprietary communications method. The structure and interpretation of the code is manufacturer specific. This allows manufacturers to establish their own methods for reporting proprietary support for PropA, PropA2, and PropB messages.

Data Length: 21 bits
 Resolution: 2097151 states/21bit, 0 offset
 Data Range: 0 to 2097151 Operational Range: same as data range
 Type: Status
 Supporting information:
 PGN 39680

SPN 4191 (R) Engine Requested Torque - High Resolution

This parameter displays an additional torque in percent of the reference engine torque.

When the MSB is set to 1, this parameter is not available. When the MSB is set to 0, bits 1 to 3 indicate the desired torque with resolution of 0.125%/bit. Range is from 0 to 0.875% of reference torque.

The parameter is used in combination with SPN 518 Engine Requested Torque/Torque Limit. The resulting torque/torque limit will be calculated by adding these two parameters.

Validity of Engine Requested Torque High Res has no effect on SPN 518.

Additional torque representations

0000 = +0.000%
 0001 = +0.125%
 .
 .
 0111 = +0.875%
 1000 - 1111 = not available

For example, if SPN 518 = 150 (or 25%) and this parameter is 0100, the torque would be 25.5%.

If SPN 518 = 175 (or 50%) and this parameter is 0001, the torque would be 50.125%

If SPN 518 = 175 (or 50%) and this parameter is 1111, the torque would remain 50% (no high resolution available)

Data Length: 4 bits
 Resolution: 0.125%/bit, 0 offset
 Data Range: 0 to 0.875% Operational Range: same as data range
 Type: Measured
 Supporting information:
 PGN 0

SPN 4193 (R) Engine Coolant Pump Outlet Temperature

The actual value of engine coolant temperature at the coolant pump outlet

Data Length: 1 byte
 Resolution: 1 deg C/bit, -40 deg C offset
 Data Range: -40 to 210 deg C Operational Range: same as data range
 Type: Measured
 Supporting information:
 PGN 64870

SPN 4194 (R) Engine Coolant Thermostat Opening

The current position of the Thermostat used to regulate the temperature of the engine coolant. 0% represents the thermostat allows flow to completely bypass the radiator and 100% represents the flow is fully through the radiator.

Data Length: 1 byte
 Resolution: 0.4 %/bit, 0 offset
 Data Range: 0 to 100 % Operational Range: same as data range
 Type: Measured
 Supporting information:
 PGN 64870

SPN 4195 (R) Engine Coolant Thermostat Mode

Specifies if the engine coolant thermostat valve will operate in temperature control mode or position control mode.

00 = temperature control mode
 01 = position control mode (used for service only)
 10 = reserved
 11 = don't care/reserved

Data Length: 2 bits
 Resolution: 4 states/2 bit, 0 offset
 Data Range: 0 to 3 Operational Range: same as data range
 Type: Status
 Supporting information:
 PGN 64850

SPN 4196 (R) Desired Engine Coolant Pump Outlet Temperature

Desired engine coolant temperature of the engine to an electronic thermostat. If the electronic thermostat valve is operating in position control mode (see SPN 4195) then transmit 0xFF.

Data Length: 1 byte
 Resolution: 1 deg C/bit, -40 deg C offset
 Data Range: -40 to 210 deg C Operational Range: same as data range
 Type: Measured
 Supporting information:
 PGN 64850

SPN 4197 (R) Desired Engine Coolant Thermostat Opening

Indicates the desired position of the engine coolant control valve. 0% represents the thermostat allows flow to completely bypass the radiator and 100% represents the flow is fully through the radiator. If the electronic thermostat is operating in temperature control mode (SPN 4195) then transmit 0xFF.

Data Length: 1 byte
 Resolution: 0.4 %/bit, 0 offset
 Data Range: 0 to 100 % Operational Range: same as data range
 Type: Status
 Supporting information:
 PGN 64850

SPN 4198 (R) Aftercooler Coolant Thermostat Mode

Specifies if the aftercooler coolant thermostat valve will operate in temperature control mode or position control mode.

00 = temperature control mode
 01 = position control mode (used for service only)
 10 = reserved
 11 = don't care/reserved

Data Length: 2 bits
 Resolution: 4 states/2 bit, 0 offset
 Data Range: 0 to 3 Operational Range: same as data range
 Type: Status
 Supporting information:
 PGN 64849

SPN 4199 (R) Desired Aftercooler Coolant Inlet Temperature

Indicates the desired temperature of the fluid in the low temperature aftercooler circuit to an electronic thermostat. If the aftercooler coolant thermostat valve is operating in position control mode (see SPN 4198) then this value should be 0xFF.

Data Length: 1 byte
 Resolution: 1 deg C/bit, -40 deg C offset
 Data Range: -40 to 210 deg C Operational Range: same as data range
 Type: Status
 Supporting information:
 PGN 64849

SPN 4200 (R) Desired Aftercooler Coolant Thermostat Opening

Used to transmit the desired position of the low temperature aftercooler temperature control valve. 0% represents the thermostat allows flow to completely bypass the aftercooler and 100% represents the flow is fully through the aftercooler.

If the aftercooler coolant thermostat is operating in temperature control mode (see SPN 4198) then this value should be 0xFF.

Data Length: 1 byte
 Resolution: 0.4 %/bit, 0 offset
 Data Range: 0 to 100 % Operational Range: same as data range
 Type: Status
 Supporting information:
 PGN 64849

SPN 4201 (R) Engine Speed 1

The engine speed as measured by speed sensor 1.

Note: This is for the engine speed from the 1st engine speed sensor. This may be different than SPN 190 when used in multiple engine speed sensor configurations. In an application with only one speed sensor, SPN 190 will represent both the speed and the sensor for diagnostic purposes and SPN 4201 will not be used. However, in an application with multiple engine speed sensors, SPN 190 data can be derived from any of the speed sensors.

Data Length: 2 bytes
Resolution: 0.5 rpm/bit, 0 offset
Data Range: 0 to 32,127.5 rpm Operational Range: same as data range
Type: Measured
Supporting information:
PGN 61473

SPN 4202 (R) Engine Speed 3

The engine speed as measured by speed sensor 3.

Note: This is for the engine speed from the 3rd engine speed sensor. This may be different than SPN 190 when used in multiple engine speed sensor configurations. In an application with multiple engine speed sensors, SPN 190 data can be derived from any of the speed sensors.

Data Length: 2 bytes
Resolution: 0.5 rpm/bit, 0 offset
Data Range: 0 to 32,127.5 rpm Operational Range: same as data range
Type: Measured
Supporting information:
PGN 61473

SPN 4203 (R) Engine Speed Sensor 1 Timing Pattern Status

This is the timing pattern status of the engine speed sensor signal for sensor 1. The sensor may be sending a speed signal but the pattern may not be valid. Since the speed is considered valid, the error indicator will not be used in the engine speed parameter (SPN 4201). The sensor does give a speed but the pattern is not matched. In this condition, the position of the crank has not been determined so injection is not enabled. The engine speed signal provides both engine speed and crankshaft location information to the engine control. A "Not OK" status may be caused by extra or missing teeth, gear runout, etc.

00 = Not OK
01 = OK
10 = Error
11 = Not available

Note: This is intended to be used on a service tool for troubleshooting a no start condition.

Data Length: 2 bits
Resolution: 4 states/2 bit, 0 offset
Data Range: 0 to 3 Operational Range: same as data range
Type: Status
Supporting information:
PGN 61473

SPN 4204 (R) Engine Speed Sensor 2 Timing Pattern Status

This is the timing pattern status of the engine speed sensor signal for sensor 2. The sensor may be sending a speed signal but the pattern may not be valid. Since the speed is considered valid, the error indicator will not be used in the engine speed parameter (SPN 723).

00 = Not OK
01 = OK
10 = Error
11 = Not available

Note: This is intended to be used on a service tool for troubleshooting a no start condition. The sensor does give a speed but the pattern is not matched. In this condition, the position of the crank has not been determined so injection is not enabled. The engine speed signal provides both engine speed and crankshaft location information to the engine control. A "Not OK" status may be caused by extra or missing teeth, gear runout, etc.

Data Length: 2 bits
Resolution: 4 states/2 bit, 0 offset
Data Range: 0 to 3 Operational Range: same as data range
Type: Status
Supporting information:
PGN 61473

SPN 4205 (R) Engine Speed Sensor 3 Timing Pattern Status

This is the timing pattern status of the engine speed sensor signal for sensor 3. The sensor may be sending a speed signal but the pattern may not be valid. Since the speed is considered valid, the error indicator will not be used in the engine speed parameter (SPN 4202).

00 = Not OK
01 = OK
10 = Error
11 = Not available

Note: This is intended to be used on a service tool for troubleshooting a no start condition. The sensor does give a speed but the pattern is not matched. In this condition, the position of the crank has not been determined so injection is not enabled. The engine speed signal provides both engine speed and crankshaft location information to the engine control. A "Not OK" status may be caused by extra or missing teeth, gear runout, etc.

Data Length: 2 bits
Resolution: 4 states/2 bit, 0 offset
Data Range: 0 to 3 Operational Range: same as data range
Type: Status
Supporting information:
PGN 61473

SPN 4206 (R) Message Counter

The message counter is used to detect situations where the transmitting ECU malfunction repeats the same frame all the time. The receiver of the information may use the counter parameter to detect this situation. The transmitting device will increase the message counter in every cycle. The message counter will count from 0 to 7 and then wrap.

The values 0x8 thru 0xE are SAE reserved and should be ignored by the receiver.

Value 0xF (all bits set to 1) will indicate that the message counter is not available. For compatibility purposes, TSC1 should also be honored if the message counter is not available from the transmitting device.

Data Length: 4 bits
 Resolution: 1 count/bit, 0 offset
 Data Range: 0 to 15 Operational Range: 0 to 7 and 15 exclusively
 Type: Status
 Supporting information:
 PGN 0

SPN 4207 (R) Message Checksum

The checksum is used to verify the signal path from the transmitting device to the receiving device.

The checksum is the sum of the high nibble and the low nibble of the sum of the identifier, the first 7 data bytes and the message counter. It is calculated as follows:

Checksum = (Byte1 + Byte2 + Byte3 + Byte4 + Byte5 + Byte6 + Byte7 + message counter & 0x0F + message ID low byte + message ID mid low byte + message ID mid high byte + message ID high byte)

Checksum = ((Checksum >> 6) + (Checksum >>3) + Checksum) & 0x07

Value 0xF (all bits set to 1) will indicate that the checksum is not available. For compatibility purposes, TSC1 should also be honored if the checksum is not available from the transmitting device.

Data Length: 4 bits
 Resolution: 1 count/bit, 0 offset
 Data Range: 0 to 15 Operational Range: same as data range
 Type: Status
 Supporting information:
 PGN 0

SPN 4211 (R) Hydraulic Fan Motor Pressure

The hydraulic pressure used to drive the fan system, sensed before the hydraulic fan motor.

Data Length: 2 bytes
 Resolution: 0.5 kPa/bit, 0 offset
 Data Range: 0 to 32,127.5 kPa Operational Range: same as data range
 Type: Measured
 Supporting information:
 PGN 65213

SPN 4212 (R) Fan Drive Bypass Command Status

Status of the Fan Drive Bypass Command as being commanded by the ECU. The fan drive bypass diverts pump pressure away from the hydraulic motor to maintain the fan drive pressure. 0% is defined as no bypass (i.e. diverting no fan drive pressure) and 100% is defined as full bypass (i.e. diverting the maximum fan drive pressure) from the fan motor.

Data Length: 1 byte
Resolution: 0.4 %/bit, 0 offset
Data Range: 0 to 100 % Operational Range: same as data range
Type: Status
Supporting information:
PGN 65213

SPN 4233 (R) Retarder Road Speed Limit Switch

Retarder road speed limit switch states:

00 Road speed limiting by retarder is disabled
01 Road speed limiting by retarder is enabled. The road speed that the retarder will limit will be determined when the switch transitions from 00 to 01
10 Error Indicator
11 Not Available

Data Length: 2 bits
Resolution: 4 states/2 bit, 0 offset
Data Range: 0 to 3 Operational Range: same as data range
Type: Measured
Supporting information:
PGN 61440

SPN 4234 (R) Retarder Road Speed Exceeded Status

Retarder Road Speed Exceeded Status:

00 Road speed is below threshold
01 Road speed is above threshold and retarder is allowed to be activated
10 Reserved
11 Don't care/Take no action

Data Length: 2 bits
Resolution: 4 states/2 bit, 0 offset
Data Range: 0 to 3 Operational Range: same as data range
Type: Status
Supporting information:
PGN 61440

SPN 4236 (R) Short-term Fuel Trim - Bank 1

This parameter is the short-term percent change in fueling based on the O2 sensor feedback for cylinder bank 1, based on the operating point in the nominal fuel map.

Note: This is similar to SPN 1695, but with higher resolution.

Data Length: 2 bytes
Resolution: 0.1 %/bit, -100 offset
Data Range: -100 to 100 % Operational Range: same as data range
Type: Status
Supporting information:
PGN 64841

SPN 4237 (R) Long-term Fuel Trim - Bank 1

This parameter is the long-term percent change in fueling based on the O2 sensor feedback for cylinder bank 1, based on the operating point in the nominal fuel map.

Data Length: 2 bytes
Resolution: 0.1 %/bit, -100 offset
Data Range: -100 to 100 % Operational Range: same as data range
Type: Status
Supporting information:
PGN 64841

SPN 4238 (R) Short-term Fuel Trim - Bank 2

This parameter is the short-term percent change in fueling based on the O2 sensor feedback for cylinder bank 2, based on the operating point in the nominal fuel map.

Data Length: 2 bytes
Resolution: 0.1 %/bit, -100 offset
Data Range: -100 to 100 % Operational Range: same as data range
Type: Status
Supporting information:
PGN 64840

SPN 4239 (R) Long-term Fuel Trim - Bank 2

This parameter is the long-term percent change in fueling based on the O2 sensor feedback for cylinder bank 2, based on the operating point in the nominal fuel map.

Data Length: 2 bytes
Resolution: 0.1 %/bit, -100 offset
Data Range: -100 to 100 % Operational Range: same as data range
Type: Status
Supporting information:
PGN 64840

SPN 4240 (R) Engine Exhaust Gas Oxygen Sensor Closed Loop Operation, bank 1

This parameter indicates the status of the bank 1 O2 sensor feedback closed loop operation

0000 = Open loop - has not yet satisfied conditions to go closed loop
0001 = Closed loop - using oxygen sensor(s) as feedback for fuel control
0010 = Open loop due to driving conditions (e.g., power enrichment, deceleration enleanment)
0011 = Open loop - due to detected system fault
0100 = Closed loop, but fault with at least one oxygen sensor - may be using single oxygen sensor for fuel control
0101-1110 = reserved
1111 = not supported

See also SPN 1696 as an prior implementation.

Data Length: 4 bits
Resolution: 16 states/4 bit, 0 offset
Data Range: 0 to 15 Operational Range: same as data range
Type: Status
Supporting information:
PGN 64841

SPN 4241 (R) Engine Exhaust Gas Oxygen Sensor Closed Loop Operation, bank 2

This parameter indicates the status of the bank 2 O2 sensor feedback closed loop operation

0000 = Open loop - has not yet satisfied conditions to go closed loop
0001 = Closed loop - using oxygen sensor(s) as feedback for fuel control
0010 = Open loop due to driving conditions (e.g., power enrichment, deceleration enleanment)
0011 = Open loop - due to detected system fault
0100 = Closed loop, but fault with at least one oxygen sensor - may be using single oxygen sensor for fuel control
0101-1110 = reserved
1111 = not supported

Data Length: 4 bits
Resolution: 16 states/4 bit, 0 offset
Data Range: 0 to 15 Operational Range: same as data range
Type: Status
Supporting information:
PGN 64840

SPN 4242 (R) Transmission Reverse Gear Shift Inhibit Request

Allows devices external to the normal transmission shift selector system to request the transmission to inhibit shifts into any Reverse gear and force the transmission into Neutral if it is currently in Reverse or attempting to shift to Reverse. These transmission responses occur regardless of shift selector (Forward, Neutral or Reverse) position at the time the request is received.

This request would typically come from a component wishing to override the vehicle operator's ability to shift or keep the transmission in Reverse. For example, the control system of a rear-loading refuse packer may wish to prevent shifts to reverse when it detects the presence of someone behind the vehicle.

Reverse gear shift inhibits include all 'Neutral-to-Reverse' shifts and 'Forward-to-Reverse' shifts; the ability of the transmission to complete 'Neutral-to-Forward' or 'Forward-to-Forward' gear shifts is not impacted.

If the transmission is in Reverse or attempting to shift to Reverse and receives an active Reverse gear shift inhibit request (0b01), the transmission will shift to Neutral. When the request subsequently goes inactive (0b00), the transmission will remain in Neutral until it receives a selector input from the vehicle operator requesting it to shift into a Non-Neutral gear. The transmission should not automatically return to the previous gear when this signal goes inactive.

Transmission response to this request can be monitored via SPN 4261 – Transmission Reverse Gear Shift Inhibit Status, SPN 523 Transmission Current Gear, and SPN 524 Transmission Selected Gear.

00 = Allow shifts into Reverse gear

01 = Inhibit shifts into Reverse gear, and shift transmission to Neutral if already in Reverse or attempting to shift to Reverse

10 = Reserved

11 = Take no action

Data Length: 2 bits

Resolution: 4 states/2 bit, 0 offset

Data Range: 0 to 3

Operational Range: same as data range

Type: Status

Supporting information:

PGN 256

SPN 4246 (R) Transmission Mode 5

Indicates whether transmission mode 5 is enabled. Modes are manufacturer specific and are not necessarily mutually exclusive. See also SPN 4250.

00 Disable

01 Enable

10 Reserved

11 Take no action

Data Length: 2 bits

Resolution: 4 states/2 bit, 0 offset

Data Range: 0 to 3

Operational Range: same as data range

Type: Status

Supporting information:

PGN 256

SPN 4247 (R) Transmission Mode 6

Indicates whether transmission mode 6 is enabled. Modes are manufacturer specific and are not necessarily mutually exclusive. See also SPN 4251.

00 Disable
01 Enable
10 Reserved
11 Take no action

Data Length: 2 bits
Resolution: 4 states/2 bit, 0 offset
Data Range: 0 to 3 Operational Range: same as data range
Type: Status
Supporting information:
PGN 256

SPN 4248 (R) Transmission Mode 7

Indicates whether transmission mode 7 is enabled. Modes are manufacturer specific and are not necessarily mutually exclusive. See also SPN 4252.

00 Disable
01 Enable
10 Reserved
11 Take no action

Data Length: 2 bits
Resolution: 4 states/2 bit, 0 offset
Data Range: 0 to 3 Operational Range: same as data range
Type: Status
Supporting information:
PGN 256

SPN 4249 (R) Transmission Mode 8

Indicates whether transmission mode 8 is enabled. Modes are manufacturer specific and are not necessarily mutually exclusive. See also SPN 4253.

00 Disable
01 Enable
10 Reserved
11 Take no action

Data Length: 2 bits
Resolution: 4 states/2 bit, 0 offset
Data Range: 0 to 3 Operational Range: same as data range
Type: Status
Supporting information:
PGN 256

SPN 4250 (R) Transmission Mode 5 Indicator

Indicates whether transmission mode 5 is enabled. Modes are manufacturer specific and are not necessarily mutually exclusive. See also SPN 4246.

00 Disable
01 Enable
10 Reserved
11 Take no action

Data Length: 2 bits
Resolution: 4 states/2 bit, 0 offset
Data Range: 0 to 3 Operational Range: same as data range
Type: Status
Supporting information:
PGN 65098

SPN 4251 (R) Transmission Mode 6 Indicator

Indicates whether transmission mode 6 is enabled. Modes are manufacturer specific and are not necessarily mutually exclusive. See also SPN 4247.

00 Disable
01 Enable
10 Reserved
11 Take no action

Data Length: 2 bits
Resolution: 4 states/2 bit, 0 offset
Data Range: 0 to 3 Operational Range: same as data range
Type: Status
Supporting information:
PGN 65098

SPN 4252 (R) Transmission Mode 7 Indicator

Indicates whether transmission mode 7 is enabled. Modes are manufacturer specific and are not necessarily mutually exclusive. See also SPN 4248.

00 Disable
01 Enable
10 Reserved
11 Take no action

Data Length: 2 bits
Resolution: 4 states/2 bit, 0 offset
Data Range: 0 to 3 Operational Range: same as data range
Type: Status
Supporting information:
PGN 65098

SPN 4253 (R) Transmission Mode 8 Indicator

Indicates whether transmission mode 8 is enabled. Modes are manufacturer specific and are not necessarily mutually exclusive. See also SPN 4249.

00 Disable
01 Enable
10 Reserved
11 Take no action

Data Length: 2 bits
Resolution: 4 states/2 bit, 0 offset
Data Range: 0 to 3 Operational Range: same as data range
Type: Status
Supporting information:
PGN 65098

SPN 4254 (R) Transmission Mode Label

Conveys ASCII 'labels' for each of the manufacturer-specified TC1 Transmission Mode 'x' / ETC7 Transmission Mode Indicator 'x' pairs. Intended for use with on-board or service tool displays. There are up to 8 fields (for Transmission Mode 1 through Transmission Mode 8), and each is separated by an ASCII asterisk delimiter "*". It is not necessary to include all fields; however, the delimiter is always required.

Data Length: 25 bytes
Resolution: ASCII, 0 offset
Data Range: 0 to 255 per byte Operational Range: same as data range
Type: Measured
Supporting information:
PGN 64839

SPN 4255 (R) Transmission Requested Launch Gear

Initial gear for the transmission to start out in when the vehicle is launched from a standing stop, as specified by the vehicle operator or vehicle system. Automatic transmissions typically default to starting out in 1st gear. However, in applications such as those with very low gearing, it is desirable to launch the vehicle in a range higher than 1st. For example, when the vehicle has little or no payload, the operator may wish to launch from 2nd or 3rd gear to avoid stacked, unnecessary shifts in the lower ranges.

0000 = No specific launch gear requested; use default launch gear

0001 = Launch the vehicle in 1st gear

0010 = Launch the vehicle in 2nd gear

0011 = Launch the vehicle in 3rd gear

0100 = Launch the vehicle in 4th gear

0101 = Launch the vehicle in 5th gear

0110 = Launch the vehicle in 6th gear

0111 = Launch the vehicle in 7th gear

1000 = Launch the vehicle in 8th gear

1001 = Launch the vehicle in Reverse 1

1010 = Launch the vehicle in Reverse 2

1011 = Launch the vehicle in Reverse 3

1100 = Launch the vehicle in Reverse 4

1101 = Reserved

1110 = Error

1111 = Not Available

Data Length: 4 bits

Resolution: 16 states/4 bit, 0 offset

Data Range: 0 to 15

Operational Range: same as data range

Type: Measured

Supporting information:

PGN 256

SPN 4261 (R) Transmission Reverse Gear Shift Inhibit Status

Reflects the status of transmission reverse inhibit activity in response to requests via SPN 4242 - Transmission Reverse Gear Shift Inhibit Request. Typically broadcast by the transmission controller.

00 = Reverse gear shifts are currently allowed

01 = Reverse gear shifts are currently inhibited

10 = Error

11 = Not Available

Data Length: 2 bits

Resolution: 4 states/2 bit, 0 offset

Data Range: 0 to 3

Operational Range: same as data range

Type: Measured

Supporting information:

PGN 65098

APPENDIX C
PGNs

PGN 0 (R) Torque/Speed Control 1 - TSC1

NOTE - Retarder may be disabled by commanding a torque limit of 0%. Use of the limit mode allows the use of the retarder only up to the limit specified in the request. This can be used to permit retarding of up to 50%, for example, if that limit is required by some device such as an EBS, or it can disable the use of the retarder by others, as when an ABS controller detects wheel slip.

Note that the 10 ms transmission repetition rate is intended for temporary powertrain control (P32 of SPN 3350). Slower transmission rates (for control purposes P1 through P31 of SPN 3350) may be supported for longer duration control.

Transmission Repetition Rate: to engine: Control Purpose dependent or 10 ms
to retarder: 50 ms

Data Length: 8

Extended Data Page: 0

Data Page: 0

PDU Format: 0

PDU Specific: DA PGN Supporting Information:

Default Priority: 3

Parameter Group Number: 0 (0x0)

Start Position	Length	Parameter Name	SPN
1.1	2 bits	Engine Override Control Mode	695
1.3	2 bits	Engine Requested Speed Control Conditions	696
1.5	2 bits	Override Control Mode Priority	897
2-3	2 bytes	Engine Requested Speed/Speed Limit	898
4	1 byte	Engine Requested Torque/Torque Limit	518
5.1	3 bits	TSC1 Transmission Rate	3349
5.4	5 bits	TSC1 Control Purpose	3350
6.1	4 bits	Engine Requested Torque - High Resolution	4191
8.1	4 bits	Message Counter	4206
8.5	4 bits	Message Checksum	4207

PGN 256 (R) Transmission Control 1**- TC1**

Transmission Repetition Rate: when active; 50 ms to transmission and axles

Data Length: 8

Extended Data Page: 0

Data Page: 0

PDU Format: 1

PDU Specific: DA PGN Supporting Information:

Default Priority: 3

Parameter Group Number: 256 (0x100)

Start Position	Length	Parameter Name	SPN
1.1	2 bits	Transmission Gear Shift Inhibit Request	681
1.3	2 bits	Transmission Torque Converter Lockup Disable Request	682
1.5	2 bits	Disengage Driveline Request	683
1.7	2 bits	Transmission Reverse Gear Shift Inhibit Request	4242
2	1 byte	Requested Percent Clutch Slip	684
3	1 byte	Transmission Requested Gear	525
4.1	2 bits	Disengage Differential Lock Request - Front Axle 1	685
4.3	2 bits	Disengage Differential Lock Request - Front Axle 2	686
4.5	2 bits	Disengage Differential Lock Request - Rear Axle 1	687
4.7	2 bits	Disengage Differential Lock Request - Rear Axle 2	688
5.1	2 bits	Disengage Differential Lock Request - Central	689
5.3	2 bits	Disengage Differential Lock Request - Central Front	690
5.5	2 bits	Disengage Differential Lock Request - Central Rear	691
6.1	2 bits	Transmission Mode 1	1852
6.3	2 bits	Transmission Mode 2	1853
6.5	2 bits	Transmission Mode 3	1854
6.7	2 bits	Transmission Mode 4	1855
7.3	4 bits	Transmission Requested Launch Gear	4255
7.7	2 bits	Transmission Shift Selector Display Mode Switch	2985
8.1	2 bits	Transmission Mode 5	4246
8.3	2 bits	Transmission Mode 6	4247
8.5	2 bits	Transmission Mode 7	4248
8.7	2 bits	Transmission Mode 8	4249

PGN 1024**External Brake Request****- XBR**

Used for brake control by an external device. The receiver is the brake system controlling the axle and/or wheel brakes. This system has to process the demanded acceleration. Note: This PGN shall not be used for external control of engine, engine brakes (engine retarders) or driveline retarders. Use TSC1 PGN instead.

Transmission Repetition Rate: when active: 20 ms; else 200 ms

Data Length: 8

Extended Data Page: 0

Data Page: 0

PDU Format: 4

PDU Specific: DA PGN Supporting Information: See Appendix D - PGN 1024

Default Priority: 3

Parameter Group Number: 1024 (0x400)

Start Position	Length	Parameter Name	SPN
1-2	2 bytes	External Acceleration Demand	2920
3.1	2 bits	XBR EBI Mode	2914
3.3	2 bits	XBR Priority	2915
3.5	2 bits	XBR Control Mode	2916
4	1 byte	XBR urgency	4099
8.1	4 bits	XBR Message Counter	3189
8.5	4 bits	XBR Message Checksum	3188

PGN 1792**General Purpose Valve Pressure****- GPV4**

The measured load sense pressure and pilot pressure of a valve. May also include the load sense and supply pressure for a valve assembly, when available.

Transmission Repetition Rate: 100 ms
 Data Length: 8
 Extended Data Page: 0
 Data Page: 0
 PDU Format: 7
 PDU Specific: DA PGN Supporting Information:
 Default Priority: 6
 Parameter Group Number: 1792 (0x700)

Start Position	Length	Parameter Name	SPN
1-2	2 bytes	Valve Load Sense Pressure	4086
3	1 byte	Valve Pilot Pressure	4087
4-5	2 bytes	Valve Assembly Load sense Pressure	4088
6-7	2 bytes	Valve Assembly Supply Pressure	4089

PGN 2048**(R) Auxiliary Input/Output Status 5****- AUXIO5**

Notes:

Implementers are encouraged to use specific functional SPNs whenever possible.

AUXIO PGNs are intended for two categories of use in which fixed mapping to functions is not possible:

- 1) Generic I/O devices
 - 2) Applications lacking defined input and output functionality.
- Use, or request new, functionally defined parameters in all other cases.

Implementers and integrators considering using AUXIO PGNs should be cautious of conflicts that can arise from multiple users on a single system.

Transmission Repetition Rate: manufacturer defined, not faster than 20 ms
 Data Length: 8
 Extended Data Page: 0
 Data Page: 0
 PDU Format: 8
 PDU Specific: DA PGN Supporting Information:
 Default Priority: 3
 Parameter Group Number: 2048 (0x800)

Start Position	Length	Parameter Name	SPN
1-2	2 bytes	Auxiliary I/O Channel #6	4155
3-4	2 bytes	Auxiliary I/O Channel #5	4156
5-6	2 bytes	Auxiliary I/O Channel #4	4157
7-8	2 bytes	Auxiliary I/O Channel #3	4158

PGN 39680 (R) Proprietary Method Identification**- PMI**

This is a standardized mechanism for an ECU to report a listing of the manufacturer specific (i.e. proprietary) methods and formats it supports when using the PropA, PropA2, and PropB PGNs (see J1939-21). The ability to support multiple manufacturer proprietary methods allows manufacturers to collaborate on application specific communication needs that are not of interest to the SAE J1939 committee. The process of selecting a specific method for ECUs that list multiple mutually exclusive methods is intended to be defined by the manufacturer and therefore not within the scope of this PGN.

NOTE—The placement of the Data Dictionary Manufacturer Code and Data Dictionary Method bits into the 4-byte space is illustrated in Figure 39680_A (See Appendix D).

Transmission Repetition Rate: On request
 Data Length: Variable
 Extended Data Page: 0
 Data Page: 0
 PDU Format: 155
 PDU Specific: DA PGN Supporting Information: See Appendix D - PGN 39680
 Default Priority: 6
 Parameter Group Number: 39680 (0x9B00)

Start Position	Length	Parameter Name	SPN
1-2.1	11 bits	Data Dictionary Manufacturer Code	4180
2.4-4	21 bits	Data Dictionary Method	4181

PGN 39936 (R) Auxiliary Input/Output Status 7**- AUXIO7**

Notes:

Implementers are encouraged to use specific functional SPNs whenever possible.

AUXIO PGNs are intended for two categories of use in which fixed mapping to functions is not possible:

- 1) Generic I/O devices
 - 2) Applications lacking defined input and output functionality.
- Use, or request new, functionally defined parameters in all other cases.

Implementers and integrators considering using AUXIO PGNs should be cautious of conflicts that can arise from multiple users on a single system.

Transmission Repetition Rate: manufacturer defined, not faster than 100 ms
 Data Length: 8
 Extended Data Page: 0
 Data Page: 0
 PDU Format: 156
 PDU Specific: DA PGN Supporting Information:
 Default Priority: 6
 Parameter Group Number: 39936 (0x9C00)

Start Position	Length	Parameter Name	SPN
1	1 byte	Auxiliary I/O Channel #18	4167
2	1 byte	Auxiliary I/O Channel #17	4168
3	1 byte	Auxiliary I/O Channel #16	4169
4	1 byte	Auxiliary I/O Channel #15	4170
5	1 byte	Auxiliary I/O Channel #22	4171
6	1 byte	Auxiliary I/O Channel #21	4172
7	1 byte	Auxiliary I/O Channel #20	4173
8	1 byte	Auxiliary I/O Channel #19	4174

PGN 40192 (R) Auxiliary Input/Output Status 6**- AUXIO6**

Notes:

Implementers are encouraged to use specific functional SPNs whenever possible.

AUXIO PGNs are intended for two categories of use in which fixed mapping to functions is not possible:

- 1) Generic I/O devices
 - 2) Applications lacking defined input and output functionality.
- Use, or request new, functionally defined parameters in all other cases.

Implementers and integrators considering using AUXIO PGNs should be cautious of conflicts that can arise from multiple users on a single system.

Transmission Repetition Rate: manufacturer defined, not faster than 100 ms

Data Length: 8

Extended Data Page: 0

Data Page: 0

PDU Format: 157

PDU Specific: DA PGN Supporting Information:

Default Priority: 6

Parameter Group Number: 40192 (0x9D00)

Start Position	Length	Parameter Name	SPN
1	1 byte	Auxiliary I/O Channel #10	4159
2	1 byte	Auxiliary I/O Channel #9	4160
3	1 byte	Auxiliary I/O Channel #8	4161
4	1 byte	Auxiliary I/O Channel #7	4162
5	1 byte	Auxiliary I/O Channel #14	4163
6	1 byte	Auxiliary I/O Channel #13	4164
7	1 byte	Auxiliary I/O Channel #12	4165
8	1 byte	Auxiliary I/O Channel #11	4166

PGN 42240**Auxiliary Input/Output Status 4****- AUXIO4**

Notes:

Implementers are encouraged to use specific functional SPNs whenever possible.

AUXIO PGNs are intended for two categories of use in which fixed mapping to functions is not possible:

- 1) Generic I/O devices
 - 2) Applications lacking defined input and output functionality.
- Use, or request new, functionally defined parameters in all other cases.

Implementers and integrators considering using AUXIO PGNs should be cautious of conflicts that can arise from multiple users on a single system.

Transmission Repetition Rate: manufacturer defined, not faster than 100 ms
 Data Length: 8
 Extended Data Page: 0
 Data Page: 0
 PDU Format: 165
 PDU Specific: DA PGN Supporting Information:
 Default Priority: 6
 Parameter Group Number: 42240 (0xA500)

Start Position	Length	Parameter Name	SPN
1.1	2 bits	Auxiliary I/O #84	3907
1.3	2 bits	Auxiliary I/O #83	3906
1.5	2 bits	Auxiliary I/O #82	3905
1.7	2 bits	Auxiliary I/O #81	3904
2.1	2 bits	Auxiliary I/O #88	3911
2.3	2 bits	Auxiliary I/O #87	3910
2.5	2 bits	Auxiliary I/O #86	3909
2.7	2 bits	Auxiliary I/O #85	3908
3.1	2 bits	Auxiliary I/O #92	3915
3.3	2 bits	Auxiliary I/O #91	3914
3.5	2 bits	Auxiliary I/O #90	3913
3.7	2 bits	Auxiliary I/O #89	3912
4.1	2 bits	Auxiliary I/O #96	3919
4.3	2 bits	Auxiliary I/O #95	3918
4.5	2 bits	Auxiliary I/O #94	3917
4.7	2 bits	Auxiliary I/O #93	3916
5.1	2 bits	Auxiliary I/O #100	3923
5.3	2 bits	Auxiliary I/O #99	3922
5.5	2 bits	Auxiliary I/O #98	3921
5.7	2 bits	Auxiliary I/O #97	3920
6.1	2 bits	Auxiliary I/O #104	3927
6.3	2 bits	Auxiliary I/O #103	3926
6.5	2 bits	Auxiliary I/O #102	3925
6.7	2 bits	Auxiliary I/O #101	3924
7.1	2 bits	Auxiliary I/O #108	3931
7.3	2 bits	Auxiliary I/O #107	3930
7.5	2 bits	Auxiliary I/O #106	3929
7.7	2 bits	Auxiliary I/O #105	3928
8.1	2 bits	Auxiliary I/O #112	3935
8.3	2 bits	Auxiliary I/O #111	3934
8.5	2 bits	Auxiliary I/O #110	3933
8.7	2 bits	Auxiliary I/O #109	3932

PGN 42496**Auxiliary Input/Output Status 3****- AUXIO3**

Notes:

Implementers are encouraged to use specific functional SPNs whenever possible.

AUXIO PGNs are intended for two categories of use in which fixed mapping to functions is not possible:

- 1) Generic I/O devices
 - 2) Applications lacking defined input and output functionality.
- Use, or request new, functionally defined parameters in all other cases.

Implementers and integrators considering using AUXIO PGNs should be cautious of conflicts that can arise from multiple users on a single system.

Transmission Repetition Rate: manufacturer defined, not faster than 100 ms

Data Length: 8

Extended Data Page: 0

Data Page: 0

PDU Format: 166

PDU Specific: DA PGN Supporting Information:

Default Priority: 6

Parameter Group Number: 42496 (0xA600)

Start Position	Length	Parameter Name	SPN
1.1	2 bits	Auxiliary I/O #52	3875
1.3	2 bits	Auxiliary I/O #51	3874
1.5	2 bits	Auxiliary I/O #50	3873
1.7	2 bits	Auxiliary I/O #49	3872
2.1	2 bits	Auxiliary I/O #56	3879
2.3	2 bits	Auxiliary I/O #55	3878
2.5	2 bits	Auxiliary I/O #54	3877
2.7	2 bits	Auxiliary I/O #53	3876
3.1	2 bits	Auxiliary I/O #60	3883
3.3	2 bits	Auxiliary I/O #59	3882
3.5	2 bits	Auxiliary I/O #58	3881
3.7	2 bits	Auxiliary I/O #57	3880
4.1	2 bits	Auxiliary I/O #64	3887
4.3	2 bits	Auxiliary I/O #63	3886
4.5	2 bits	Auxiliary I/O #62	3885
4.7	2 bits	Auxiliary I/O #61	3884
5.1	2 bits	Auxiliary I/O #68	3891
5.3	2 bits	Auxiliary I/O #67	3890
5.5	2 bits	Auxiliary I/O #66	3889
5.7	2 bits	Auxiliary I/O #65	3888
6.1	2 bits	Auxiliary I/O #72	3895
6.3	2 bits	Auxiliary I/O #71	3894
6.5	2 bits	Auxiliary I/O #70	3893
6.7	2 bits	Auxiliary I/O #69	3892
7.1	2 bits	Auxiliary I/O #76	3899
7.3	2 bits	Auxiliary I/O #75	3898
7.5	2 bits	Auxiliary I/O #74	3897
7.7	2 bits	Auxiliary I/O #73	3896
8.1	2 bits	Auxiliary I/O #80	3903
8.3	2 bits	Auxiliary I/O #79	3902
8.5	2 bits	Auxiliary I/O #78	3901
8.7	2 bits	Auxiliary I/O #77	3900

PGN 42752**Auxiliary Input/Output Status 2****- AUXIO2**

Notes:

Implementers are encouraged to use specific functional SPNs whenever possible.

AUXIO PGNs are intended for two categories of use in which fixed mapping to functions is not possible:

- 1) Generic I/O devices
 - 2) Applications lacking defined input and output functionality.
- Use, or request new, functionally defined parameters in all other cases.

Implementers and integrators considering using AUXIO PGNs should be cautious of conflicts that can arise from multiple users on a single system.

Transmission Repetition Rate: manufacturer defined, not faster than 100 ms
 Data Length: 8
 Extended Data Page: 0
 Data Page: 0
 PDU Format: 167
 PDU Specific: DA PGN Supporting Information:
 Default Priority: 6
 Parameter Group Number: 42752 (0xA700)

Start Position	Length	Parameter Name	SPN
1.1	2 bits	Auxiliary I/O #20	3843
1.3	2 bits	Auxiliary I/O #19	3842
1.5	2 bits	Auxiliary I/O #18	3841
1.7	2 bits	Auxiliary I/O #17	3840
2.1	2 bits	Auxiliary I/O #24	3847
2.3	2 bits	Auxiliary I/O #23	3846
2.5	2 bits	Auxiliary I/O #22	3845
2.7	2 bits	Auxiliary I/O #21	3844
3.1	2 bits	Auxiliary I/O #28	3851
3.3	2 bits	Auxiliary I/O #27	3850
3.5	2 bits	Auxiliary I/O #26	3849
3.7	2 bits	Auxiliary I/O #25	3848
4.1	2 bits	Auxiliary I/O #32	3855
4.3	2 bits	Auxiliary I/O #31	3854
4.5	2 bits	Auxiliary I/O #30	3853
4.7	2 bits	Auxiliary I/O #29	3852
5.1	2 bits	Auxiliary I/O #36	3859
5.3	2 bits	Auxiliary I/O #35	3858
5.5	2 bits	Auxiliary I/O #34	3857
5.7	2 bits	Auxiliary I/O #33	3856
6.1	2 bits	Auxiliary I/O #40	3863
6.3	2 bits	Auxiliary I/O #39	3862
6.5	2 bits	Auxiliary I/O #38	3861
6.7	2 bits	Auxiliary I/O #37	3860
7.1	2 bits	Auxiliary I/O #44	3867
7.3	2 bits	Auxiliary I/O #43	3866
7.5	2 bits	Auxiliary I/O #42	3865
7.7	2 bits	Auxiliary I/O #41	3864
8.1	2 bits	Auxiliary I/O #48	3871
8.3	2 bits	Auxiliary I/O #47	3870
8.5	2 bits	Auxiliary I/O #46	3869
8.7	2 bits	Auxiliary I/O #45	3868

PGN 43008**Text Display****- DISP1**

This provides ASCII text information, for example to an display instrument. Broadcast rate should be on event and 1-5 seconds due to variable character length. This message is to convey information from an ecu to a display. In its most basic usage, it can be used to convey ASCII information to simple displays to show to the operator. The Text Display Characters will follow the standard J1939-71 display method. Control characters can be used but not displayed. The characters are to be terminated with a 00h or "null" character. Following bytes will be filled with FFh as usual. The null character will be used once per pgn transmission, regardless of character string length.

Transmission Repetition Rate: As required
 Data Length: Variable - up to 200 characters
 Extended Data Page: 0
 Data Page: 0
 PDU Format: 168
 PDU Specific: DA PGN Supporting Information:
 Default Priority: 6
 Parameter Group Number: 43008 (0xA800)

Start Position	Length	Parameter Name	SPN
1.1	4 bits	Text Display Instructions	3613
3	1 byte	Text Display Index	3614
4 to n	Variable - up to 200 characters	Text Display Character	3615

PGN 43264**Forward Lane Image Command****- FLIC**

Message containing commands, sent to the forward image controller

Transmission Repetition Rate: On event
 Data Length: 8
 Extended Data Page: 0
 Data Page: 0
 PDU Format: 169
 PDU Specific: DA PGN Supporting Information:
 Default Priority: 6
 Parameter Group Number: 43264 (0xA900)

Start Position	Length	Parameter Name	SPN
1.1	2 bits	Lane Departure Warning Enable Command	3564

PGN 44544**Tire Pressure Reference Setting****- TPRS**

For setting the tire pressure reference values.

This message is the setpoint for the PGN 64953 Tire Pressure reference information message.

Transmission Repetition Rate: As needed
 Data Length: 8
 Extended Data Page: 0
 Data Page: 0
 PDU Format: 174
 PDU Specific: DA PGN Supporting Information:
 Default Priority: 6
 Parameter Group Number: 44544 (0xAE00)

Start Position	Length	Parameter Name	SPN
1	8 bits	Tire Location	3192
2	1 byte	Reference Tire Pressure Setting	3193

PGN 52992**Continuous Torque & Speed Limit Request****- CTL**

Transmission Repetition Rate: 5 s
 Data Length: 8
 Extended Data Page: 0
 Data Page: 0
 PDU Format: 207
 PDU Specific: DA PGN Supporting Information: See Appendix D - PGN 52992
 Default Priority: 6
 Parameter Group Number: 52992 (0xCF00)

Start Position	Length	Parameter Name	SPN
1	1 byte	Engine Speed Limit Request - Minimum Continuous	1784
2	1 byte	Engine Speed Limit Request - Maximum Continuous	1785
3	1 byte	Engine Torque Limit Request - Minimum Continuous	1786
4	1 byte	Engine Torque Limit Request - Maximum Continuous	1787
5	1 byte	Minimum Continuous Retarder Speed Limit Request	1788
6	1 byte	Maximum Continuous Retarder Speed Limit Request	1789
7	1 byte	Minimum Continuous Retarder Torque Limit Request	1790
8	1 byte	Maximum Continuous Retarder Torque Limit Request	1791

PGN 53248**Cab Illumination Message****- CL**

This message contains information that controls illumination devices inside the vehicle's cab.

Transmission Repetition Rate: On change of state, but not faster than 100 ms, and every 5 s
 Data Length: 8
 Extended Data Page: 0
 Data Page: 0
 PDU Format: 208
 PDU Specific: DA PGN Supporting Information:
 Default Priority: 6
 Parameter Group Number: 53248 (0xD000)

Start Position	Length	Parameter Name	SPN
1	1 byte	Illumination Brightness Percent	1487

PGN 53504**Air Suspension Control 6****- ASC6**

Used for suspension control

Transmission Repetition Rate: 100 ms when active
 Data Length: 8
 Extended Data Page: 0
 Data Page: 0
 PDU Format: 209
 PDU Specific: DA PGN Supporting Information:
 Default Priority: 3
 Parameter Group Number: 53504 (0xD100)

Start Position	Length	Parameter Name	SPN
1-2	2 bytes	Level Preset Front Axle Left	1732
3-4	2 bytes	Level Preset Front Axle Right	1757
5-6	2 bytes	Level Preset Rear Axle Left	1758
7-8	2 bytes	Level Preset Rear Axle Right	1735

PGN 53760**Air Suspension Control 2****- ASC2**

Used for suspension control

Transmission Repetition Rate: 100 ms
 Data Length: 8
 Extended Data Page: 0
 Data Page: 0
 PDU Format: 210
 PDU Specific: DA PGN Supporting Information:
 Default Priority: 3
 Parameter Group Number: 53760 (0xD200)

Start Position	Length	Parameter Name	SPN
1.1	2 bits	Automatic traction help (load transfer)	2984
1.3	2 bits	Kneeling Request Left Side	1749
1.5	2 bits	Kneeling Request Right Side	1748
1.7	2 bits	Kneeling Control Mode Request	1747
2.1	4 bits	Nominal Level Request Front Axle	1751
2.5	4 bits	Nominal Level Request Rear Axle	1750
3.1	4 bits	Level Control Mode Request	1753
3.5	2 bits	Lift Axle 1 Position Command	1752
3.7	2 bits	Lift Axle 2 Position Command	1828
4	1 byte	Damper Stiffness Request Front Axle	1718
5	1 byte	Damper Stiffness Request Rear Axle	1719
6	1 byte	Damper Stiffness Request Lift / Tag Axle	1720
7.1	2 bits	Kneeling Command - Front Axle	1830
7.3	2 bits	Kneeling Command - Rear Axle	1829
7.5	2 bits	Prohibit air suspension control	3215

PGN 54528**Time/Date Adjust****- TDA**

Transmission Repetition Rate: As needed
 Data Length: 8
 Extended Data Page: 0
 Data Page: 0
 PDU Format: 213
 PDU Specific: DA PGN Supporting Information:
 Default Priority: 6
 Parameter Group Number: 54528 (0xD500)

Start Position	Length	Parameter Name	SPN
1	1 byte	Adjust seconds	1603
2	1 byte	Adjust minutes	1604
3	1 byte	Adjust hours	1605
4	1 byte	Adjust month	1606
5	1 byte	Adjust day	1607
6	1 byte	Adjust year	1608
7	1 byte	Adjust local minute offset	1609
8	1 byte	Adjust local hour offset	1610

PGN 56320**Anti-theft Status****- ATS**

NOTE—See Figures PGN56320_A to PGN56320_F for examples of Anti-theft message transfers. Bit 1 is the right most bit in each byte.

Transmission Repetition Rate: This message is transmitted in response to an Anti-Theft Request message. This message is also sent when the component has an abnormal power interruption. In this situation the Anti-Theft Status Report is sent without the Anti-Theft Request.

Data Length: 8
 Extended Data Page: 0
 Data Page: 0
 PDU Format: 220
 PDU Specific: DA PGN Supporting Information: See Appendix D - PGN 56320
 Default Priority: 7
 Parameter Group Number: 56320 (0xDC00)

Start Position	Length	Parameter Name	SPN
1.1	2 bits	Anti-theft Encryption Seed Present Indicator	1194
1.3	2 bits	Anti-theft Password Valid Indicator	1195
1.5	2 bits	Anti-theft Component Status States	1196
1.7	2 bits	Anti-theft Modify Password States	1197
2-8	7 bytes	Anti-theft Random Number	1198

PGN 56576**Anti-theft Request****- ATR**

NOTE—See Figures PGN56320_A thru PGN56320_F for examples of Anti-theft message transfers. Bit 1 is the right most bit in each byte.

Transmission Repetition Rate: Transmission of this message is interrupt driven. This message is also transmitted upon power-up of the interfacing device sending this message.

Data Length: 8

Extended Data Page: 0

Data Page: 0

PDU Format: 221

PDU Specific: DA PGN Supporting Information:

Default Priority: 7

Parameter Group Number: 56576 (0xDD00)

Start Position	Length	Parameter Name	SPN
1.2	2 bits	Anti-theft Encryption Indicator States	1199
1.4	2 bits	Anti-theft Desired Exit Mode States	1200
1.6	3 bits	Anti-theft Command States	1201
2	7 bytes	Anti-theft Password Representation	1202

PGN 56832**Reset****- RESET**

NOTE—This message requires an Acknowledgement response (See J1939-21, PGN 59392) from the receiving node. The use of individual proprietary protocols can still be used instead of the "trip reset" PGN to maintain security.

Transmission Repetition Rate: When needed

Data Length: 8

Extended Data Page: 0

Data Page: 0

PDU Format: 222

PDU Specific: DA PGN Supporting Information:

Default Priority: 7

Parameter Group Number: 56832 (0xDE00)

Start Position	Length	Parameter Name	SPN
1.1	2 bits	Trip Group 1	988
1.3	2 bits	Trip Group 2 - Proprietary	989
2	1 byte	Service Component Identification	1584
3.1	2 bits	Engine Build Hours Reset	1211
3.3	2 bits	Steering Straight Ahead Position Reset	3600

PGN 57344**Cab Message 1****- CM1**

Message containing parameters originating from the vehicle cab.

Transmission Repetition Rate: 1 s
 Data Length: 8
 Extended Data Page: 0
 Data Page: 0
 PDU Format: 224
 PDU Specific: DA PGN Supporting Information:
 Default Priority: 6
 Parameter Group Number: 57344 (0xE000)

Start Position	Length	Parameter Name	SPN
1	1 byte	Requested Percent Fan Speed	986
2-3	2 bytes	Cab Interior Temperature Command	1691
4.1	2 bits	Auxiliary Heater Coolant Pump Request	1684
4.3	2 bits	Battery Main Switch Hold Request	1682
4.5	2 bits	Operator Seat Direction Switch	1714
4.7	2 bits	Seat Belt Switch	1856
5.3	2 bits	Vehicle Limiting Speed Governor Decrement Switch	1655
5.5	2 bits	Vehicle Limiting Speed Governor Increment Switch	1654
5.7	2 bits	Vehicle Limiting Speed Governor Enable Switch	1653
6.1	2 bits	Diesel Particulate Filter Regeneration Inhibit Switch	3695
6.3	2 bits	Diesel Particulate Filter Regeneration Force Switch	3696
6.5	2 bits	Automatic Gear Shifting Enable Switch	1666
6.7	2 bits	Engine Automatic Start Enable Switch	1656
7.1	4 bits	Auxiliary Heater Mode Request	1683
7.5	2 bits	Request Engine Zone Heating	1685
7.7	2 bits	Request Cab Zone Heating	1686
8	1 byte	Selected Maximum Vehicle Speed Limit	2596

PGN 61440 (R) Electronic Retarder Controller 1**- ERC1**

NOTE- This message will be transmitted by several types of retarding devices such as engine compression release brakes, exhaust system restriction brakes, and driveline retarders using hydraulic, electric, or mechanical friction to slow the vehicle. The source address of the message will indicate which one, and the type and location of the retarder are available in the Retarder Configuration Message (see PGN 65249) if that detail is important to the receiver.

Users should also be aware that the Shift Assist and Brake Assist switch status in the first byte of this message are to be used by other ECUs that might request retarding force from the retarder to know when such assistance is available. The state of the "switches" will NOT prevent the retarder from activating if requested, but should be honored by the requester (by not sending a request when the appropriate "switch" is not enabled) to prevent unwarranted noise.

Transmission Repetition Rate: 100 ms
 Data Length: 8
 Extended Data Page: 0
 Data Page: 0
 PDU Format: 240
 PDU Specific: 0 PGN Supporting Information:
 Default Priority: 6
 Parameter Group Number: 61440 (0xF000)

Start Position	Length	Parameter Name	SPN
1.1	4 bits	Retarder Torque Mode	900
1.5	2 bits	Retarder Enable - Brake Assist Switch	571
1.7	2 bits	Retarder Enable - Shift Assist Switch	572
2	1 byte	Actual Retarder - Percent Torque	520
3	1 byte	Intended Retarder Percent Torque	1085
4.1	2 bits	Engine Coolant Load Increase	1082
4.3	2 bits	Retarder Requesting Brake Light	1667
4.5	2 bits	Retarder Road Speed Limit Switch	4233
4.7	2 bits	Retarder Road Speed Exceeded Status	4234
5	1 byte	Source Address of Controlling Device for Retarder Control	1480
6	1 byte	Drivers Demand Retarder - Percent Torque	1715
7	1 byte	Retarder Selection, non-engine	1716
8	1 byte	Actual Maximum Available Retarder - Percent Torque	1717

PGN 61441**Electronic Brake Controller 1****- EBC1**

Used for brake control information

Transmission Repetition Rate: 100 ms
 Data Length: 8
 Extended Data Page: 0
 Data Page: 0
 PDU Format: 240
 PDU Specific: 1 PGN Supporting Information:
 Default Priority: 6
 Parameter Group Number: 61441 (0xF001)

Start Position	Length	Parameter Name	SPN
1.1	2 bits	ASR Engine Control Active	561
1.3	2 bits	ASR Brake Control Active	562
1.5	2 bits	Anti-Lock Braking (ABS) Active	563
1.7	2 bits	EBS Brake Switch	1121
2	1 byte	Brake Pedal Position	521
3.1	2 bits	ABS Off-road Switch	575
3.3	2 bits	ASR Off-road Switch	576
3.5	2 bits	ASR "Hill Holder" Switch	577
3.7	2 bits	Traction Control Override Switch	1238
4.1	2 bits	Accelerator Interlock Switch	972
4.3	2 bits	Engine Derate Switch	971
4.5	2 bits	Engine Auxiliary Shutdown Switch	970
4.7	2 bits	Remote Accelerator Enable Switch	969
5	1 byte	Engine Retarder Selection	973
6.1	2 bits	ABS Fully Operational	1243
6.3	2 bits	EBS Red Warning Signal	1439
6.5	2 bits	ABS/EBS Amber Warning Signal (Powered Vehicle)	1438
6.7	2 bits	ATC/ASR Information Signal	1793
7	1 byte	Source Address of Controlling Device for Brake Control	1481
8.3	2 bits	Halt brake switch	2911
8.5	2 bits	Trailer ABS Status	1836
8.7	2 bits	Tractor-Mounted Trailer ABS Warning Signal	1792

PGN 61442**Electronic Transmission Controller 1****- ETC1**

Transmission Repetition Rate: 10 ms
 Data Length: 8
 Extended Data Page: 0
 Data Page: 0
 PDU Format: 240
 PDU Specific: 2 PGN Supporting Information:
 Default Priority: 3
 Parameter Group Number: 61442 (0xF002)

Start Position	Length	Parameter Name	SPN
1.1	2 bits	Transmission Driveline Engaged	560
1.3	2 bits	Transmission Torque Converter Lockup Engaged	573
1.5	2 bits	Transmission Shift In Process	574
2-3	2 bytes	Transmission Output Shaft Speed	191
4	1 byte	Percent Clutch Slip	522
5.1	2 bits	Engine Momentary Overspeed Enable	606
5.3	2 bits	Progressive Shift Disable	607
6-7	2 bytes	Transmission Input Shaft Speed	161
8	1 byte	Source Address of Controlling Device for Transmission Control	1482

PGN 61443**Electronic Engine Controller 2****- EEC2**

Identifies electronic engine control related parameters.

Transmission Repetition Rate: 50 ms
 Data Length: 8
 Extended Data Page: 0
 Data Page: 0
 PDU Format: 240
 PDU Specific: 3 PGN Supporting Information:
 Default Priority: 3
 Parameter Group Number: 61443 (0xF003)

Start Position	Length	Parameter Name	SPN
1.1	2 bits	Accelerator Pedal 1 Low Idle Switch	558
1.3	2 bits	Accelerator Pedal Kickdown Switch	559
1.5	2 bits	Road Speed Limit Status	1437
1.7	2 bits	Accelerator Pedal 2 Low Idle Switch	2970
2	1 byte	Accelerator Pedal Position 1	91
3	1 byte	Engine Percent Load At Current Speed	92
4	1 byte	Remote Accelerator Pedal Position	974
5	1 byte	Accelerator Pedal Position 2	29
6.1	2 bits	Vehicle Acceleration Rate Limit Status	2979
7	1 byte	Actual Maximum Available Engine - Percent Torque	3357

PGN 61444 (R) Electronic Engine Controller 1**- EEC1**

Engine related parameters

Transmission Repetition Rate: engine speed dependent
 Data Length: 8
 Extended Data Page: 0
 Data Page: 0
 PDU Format: 240
 PDU Specific: 4 PGN Supporting Information:
 Default Priority: 3
 Parameter Group Number: 61444 (0xF004)

Start Position	Length	Parameter Name	SPN
1.1	4 bits	Engine Torque Mode	899
1.5	4 bits	Actual Engine - Percent Torque High Resolution	4154
2	1 byte	Driver's Demand Engine - Percent Torque	512
3	1 byte	Actual Engine - Percent Torque	513
4-5	2 bytes	Engine Speed	190
6	1 byte	Source Address of Controlling Device for Engine Control	1483
7.1	4 bits	Engine Starter Mode	1675
8	1 byte	Engine Demand – Percent Torque	2432

PGN 61445 Electronic Transmission Controller 2**- ETC2**

Transmission Repetition Rate: 100 ms
 Data Length: 8
 Extended Data Page: 0
 Data Page: 0
 PDU Format: 240
 PDU Specific: 5 PGN Supporting Information:
 Default Priority: 6
 Parameter Group Number: 61445 (0xF005)

Start Position	Length	Parameter Name	SPN
1	1 byte	Transmission Selected Gear	524
2-3	2 bytes	Transmission Actual Gear Ratio	526
4	1 byte	Transmission Current Gear	523
5-6	2 bytes	Transmission Requested Range	162
7-8	2 bytes	Transmission Current Range	163

PGN 61446**Electronic Axle Controller 1****- EAC1**

NOTE - Request has to be responded to with as many messages as necessary to transmit all available information.

Transmission Repetition Rate: 500 ms
 Data Length: 8
 Extended Data Page: 0
 Data Page: 0
 PDU Format: 240
 PDU Specific: 6 PGN Supporting Information:
 Default Priority: 6
 Parameter Group Number: 61446 (0xF006)

Start Position	Length	Parameter Name	SPN
1	8 bits	Location	927
2.1	2 bits	Differential Lock State - Front Axle 1	567
2.3	2 bits	Differential Lock State - Front Axle 2	568
2.5	2 bits	Differential Lock State - Rear Axle 1	569
2.7	2 bits	Differential Lock State - Rear Axle 2	570
3.1	2 bits	Differential Lock State - Central	564
3.3	2 bits	Differential Lock State - Central Front	565
3.5	2 bits	Differential Lock State - Central Rear	566
4.1	2 bits	Front axle group engagement status	3819
4.3	2 bits	Rear axle group engagement status	3820

PGN 61447**Forward Lane Image urgent msg****- FLI1**

Transmission Repetition Rate: 50 ms (only when active)
 Data Length: 8
 Extended Data Page: 0
 Data Page: 0
 PDU Format: 240
 PDU Specific: 7 PGN Supporting Information:
 Default Priority: 4
 Parameter Group Number: 61447 (0xF007)

Start Position	Length	Parameter Name	SPN
1.1	2 bits	Lane Departure Left	3565
1.3	2 bits	Lane Departure Right	3566
1.5	2 bits	Lane Departure Imminent, Right Side	1701
1.7	2 bits	Lane Departure Imminent, Left Side	1700

PGN 61448**Hydraulic Pressure Governor Info****- HPG**

Information to be used for a hydraulic pressure governing control system

Transmission Repetition Rate: 50 ms
 Data Length: 8
 Extended Data Page: 0
 Data Page: 0
 PDU Format: 240
 PDU Specific: 8 PGN Supporting Information:
 Default Priority: 6
 Parameter Group Number: 61448 (0xF008)

Start Position	Length	Parameter Name	SPN
1-2	2 bytes	Hydraulic Pressure	1762
3.1	2 bits	Engine Hydraulic Pressure Governor Mode Indicator	1763
3.3	2 bits	Engine Hydraulic Pressure Governor Switch	1764
3.5	2 bits	Fire Apparatus Pump Engagement	2599

PGN 61449**Vehicle Dynamic Stability Control 2****- VDC2**

Contains information which relates to the vehicle's movement.

Transmission Repetition Rate: 10 ms
 Data Length: 8
 Extended Data Page: 0
 Data Page: 0
 PDU Format: 240
 PDU Specific: 9 PGN Supporting Information:
 Default Priority: 6
 Parameter Group Number: 61449 (0xF009)

Start Position	Length	Parameter Name	SPN
1-2	2 bytes	Steering Wheel Angle	1807
3.1	6 bits	Steering Wheel Turn Counter	1811
3.7	2 bits	Steering Wheel Angle Sensor Type	1812
4-5	2 bytes	Yaw Rate	1808
6-7	2 bytes	Lateral Acceleration	1809
8	1 byte	Longitudinal Acceleration	1810

PGN 61450**Engine Gas Flow Rate****- EGF1**

Flow rates of Air and mixed gasses into the engine cylinders.

Transmission Repetition Rate: 50 ms
 Data Length: 8
 Extended Data Page: 0
 Data Page: 0
 PDU Format: 240
 PDU Specific: 10 PGN Supporting Information:
 Default Priority: 3
 Parameter Group Number: 61450 (0xF00A)

Start Position	Length	Parameter Name	SPN
1-2	2 bytes	Engine Exhaust Gas Recirculation (EGR) Mass Flow Rate	2659
3-4	2 bytes	Engine Inlet Air Mass Flow Rate	132

PGN 61451**Electronic Steering Control****- ESC1**

PGN which indicates the actual angle and the status of a steerable axle

Transmission Repetition Rate: 20 ms
 Data Length: 8
 Extended Data Page: 0
 Data Page: 0
 PDU Format: 240
 PDU Specific: 11 PGN Supporting Information:
 Default Priority: 6
 Parameter Group Number: 61451 (0xF00B)

Start Position	Length	Parameter Name	SPN
1-2	2 bytes	Actual Inner wheel steering angle	2927
3	8 bits	Axle Location	2928
4.1	4 bits	Status of Steering Axle	2923
4.5	2 bits	Steerable Lift Axle Lowering Inhibit	2922
5.1	4 bits	Steering Type	2924
5.5	4 bits	Type of Steering Forces	2925
6.1	4 bits	Type of Steering Transmission	2926

PGN 61452 Electronic Transmission Controller #8 - ETC8

Electronic Transmission Controller #8

Transmission Repetition Rate: 20 ms when torque converter unlocked, 100 ms when torque converter locked
 Data Length: 8
 Extended Data Page: 0
 Data Page: 0
 PDU Format: 240
 PDU Specific: 12 PGN Supporting Information:
 Default Priority: 3
 Parameter Group Number: 61452 (0xF00C)

Start Position	Length	Parameter Name	SPN
1-2	2 bytes	Transmission Torque Converter Ratio	3030

PGN 61453 Land Leveling System Operational Information - LOI

Group of operational parameters associated with the Land Leveling System, such as switch states. This is provided to the device controlling the blade, and is usually directed at the primary land leveling controller.

Notes:

1. The parameter group is filled with SPNs sent to the Land Leveling System controller. Similar PGNs exist, 65138 for example, but PGN 65138 is sent out by the Land Leveling System primary controller to reflect the mode the land leveling system has been put into (auto, manual). This logical decision to put the system into auto/manual mode is based in part on the input from this PGN, along with other various inputs. It makes more sense to create this PGN filled with parameters sourced from the non-primary controller, rather than use the PGN sourced by the primary controller itself. In the future, other SPNs coming from the non-primary controller can be added to the PGN. There are plans to add more switch values in the future.
2. Other systems with automated blade controls should be able to use this parameter group, since it contains measured switch values.

Transmission Repetition Rate: 100 ms
 Data Length: 8
 Extended Data Page: 0
 Data Page: 0
 PDU Format: 240
 PDU Specific: 13 PGN Supporting Information:
 Default Priority: 3
 Parameter Group Number: 61453 (0xF00D)

Start Position	Length	Parameter Name	SPN
1.1	4 bits	Blade Control Mode Switch	3156
1.5	4 bits	Desired Grade Offset Switch	3157
2.1	4 bits	Blade Auto Mode Command	3158
2.5	4 bits	Left Blade Control Mode Operator Control	3334
3.1	4 bits	Right Blade Control Mode Operator Control	3335
3.5	4 bits	Left Desired Blade Offset Operator Control	3336
4.1	4 bits	Right Desired Blade Offset Operator Control	3337
4.5	4 bits	Side-shift Blade Control Mode Operator Control	3338
5.1	4 bits	Side-shift Desired Blade Offset Operator Control	3339

PGN 61454**Aftertreatment 1 Intake Gas 1****- AT1IG1**

The purpose of this PGN is to group the aftertreatment intake sensor data for bank 1. These values include the NOx, %O2, Status's of the sensors with respect to the power being supplied and the heating element, errors and stability of the readings.

Transmission Repetition Rate: 50 ms
 Data Length: 8
 Extended Data Page: 0
 Data Page: 0
 PDU Format: 240
 PDU Specific: 14 PGN Supporting Information:
 Default Priority: 6
 Parameter Group Number: 61454 (0xF00E)

Start Position	Length	Parameter Name	SPN
1-2	2 bytes	Aftertreatment 1 Intake NOx	3216
3-4	2 bytes	Aftertreatment 1 Intake %O2	3217
5.1	2 bits	Aftertreatment 1 Intake Gas Sensor Power In Range	3218
5.3	2 bits	Aftertreatment 1 Intake Gas Sensor at Temperature	3219
5.5	2 bits	Aftertreatment 1 Intake NOx Reading Stable	3220
5.7	2 bits	Aftertreatment 1 Intake Wide-Range % O2 Reading Stable	3221
6.1	5 bits	Aftertreatment 1 Intake Gas Sensor Heater Preliminary FMI	3222
6.6	2 bits	Aftertreatment 1 Intake Gas Sensor Heater Control	3223
7.1	5 bits	Aftertreatment 1 Intake NOx Sensor Preliminary FMI	3224
8.1	5 bits	Aftertreatment 1 Intake Oxygen Sensor Preliminary FMI	3225

PGN 61455**Aftertreatment 1 Outlet Gas 1****- AT1OG1**

The purpose of this PGN is to group the aftertreatment outlet sensor data for bank 1. These values include the NOx, %O2, Status's of the sensors with respect to the power being supplied and the heating element, errors and stability of the readings.

Transmission Repetition Rate: 50 ms
 Data Length: 8
 Extended Data Page: 0
 Data Page: 0
 PDU Format: 240
 PDU Specific: 15 PGN Supporting Information:
 Default Priority: 6
 Parameter Group Number: 61455 (0xF00F)

Start Position	Length	Parameter Name	SPN
1-2	2 bytes	Aftertreatment 1 Outlet NOx	3226
3-4	2 bytes	Aftertreatment 1 Outlet %O2	3227
5.1	2 bits	Aftertreatment 1 Outlet Gas Sensor Power In Range	3228
5.3	2 bits	Aftertreatment 1 Outlet Gas Sensor at Temperature	3229
5.5	2 bits	Aftertreatment 1 Outlet NOx Reading Stable	3230
5.7	2 bits	Aftertreatment 1 Outlet Wide-Range %O2 Reading Stable	3231
6.1	5 bits	Aftertreatment 1 Outlet Gas Sensor Heater Preliminary FMI	3232
6.6	2 bits	Aftertreatment 1 Outlet Gas Sensor Heater Control	3233
7.1	5 bits	Aftertreatment 1 Outlet NOx Sensor Preliminary FMI	3234
8.1	5 bits	Aftertreatment 1 Outlet Oxygen Sensor Preliminary FMI	3235

PGN 61456**Aftertreatment 2 Intake Gas 1****- AT2IG1**

The purpose of this PGN is to group the aftertreatment intake sensor data for bank 2. These values include the NOx, %O2, status of the sensors with respect to the power being supplied and the heating element, errors and stability of the readings.

Transmission Repetition Rate: 50 ms
 Data Length: 8
 Extended Data Page: 0
 Data Page: 0
 PDU Format: 240
 PDU Specific: 16 PGN Supporting Information:
 Default Priority: 6
 Parameter Group Number: 61456 (0xF010)

Start Position	Length	Parameter Name	SPN
1-2	2 bytes	Aftertreatment 2 Intake NOx	3255
3-4	2 bytes	Aftertreatment 2 Intake %O2	3256
5.1	2 bits	Aftertreatment 2 Intake Gas Sensor Power In Range	3257
5.3	2 bits	Aftertreatment 2 Intake Gas Sensor at Temperature	3258
5.5	2 bits	Aftertreatment 2 Intake NOx Reading Stable	3259
5.7	2 bits	Aftertreatment 2 Intake Wide-Range % O2 Reading Stable	3260
6.1	5 bits	Aftertreatment 2 Intake Gas Sensor Heater Preliminary FMI	3261
6.6	2 bits	Aftertreatment 2 Intake Gas Sensor Heater Control	3262
7.1	5 bits	Aftertreatment 2 Intake NOx Sensor Preliminary FMI	3263
8.1	5 bits	Aftertreatment 2 Intake Oxygen Sensor Preliminary FMI	3264

PGN 61457**Aftertreatment 2 Outlet Gas 1****- AT2OG1**

The purpose of this PGN is to group the aftertreatment outlet sensor data for bank 2. These values include the NOx, %O2, status of the sensors with respect to the power being supplied and the heating element, errors and stability of the readings.

Transmission Repetition Rate: 50 ms
 Data Length: 8
 Extended Data Page: 0
 Data Page: 0
 PDU Format: 240
 PDU Specific: 17 PGN Supporting Information:
 Default Priority: 6
 Parameter Group Number: 61457 (0xF011)

Start Position	Length	Parameter Name	SPN
1-2	2 bytes	Aftertreatment 2 Outlet NOx	3265
3-4	2 bytes	Aftertreatment 2 Outlet %O2	3266
5.1	2 bits	Aftertreatment 2 Outlet Gas Sensor Power In Range	3267
5.3	2 bits	Aftertreatment 2 Outlet Gas Sensor at Temperature	3268
5.5	2 bits	Aftertreatment 2 Outlet NOx Reading Stable	3269
5.7	2 bits	Aftertreatment 2 Outlet Wide-Range % O2 Reading Stable	3270
6.1	5 bits	Aftertreatment 2 Outlet Gas Sensor Heater Preliminary FMI	3271
6.6	2 bits	Aftertreatment 2 Outlet Gas Sensor Heater Control	3272
7.1	5 bits	Aftertreatment 2 Outlet NOx Sensor Preliminary FMI	3273
8.1	5 bits	Aftertreatment 2 Outlet Oxygen Sensor Preliminary FMI	3274

PGN 61458**Fifth Wheel Smart Systems 1****- FWSS1**

Fifth wheel smart system information. Parameters used to determine the status of the tractor to trailer coupling system integrity.

Transmission Repetition Rate: 50 ms
 Data Length: 8
 Extended Data Page: 0
 Data Page: 0
 PDU Format: 240
 PDU Specific: 18 PGN Supporting Information:
 Default Priority: 6
 Parameter Group Number: 61458 (0xF012)

Start Position	Length	Parameter Name	SPN
1	2 bytes	Fifth Wheel Vertical Force	3308
3	2 bytes	Fifth Wheel Drawbar Force	3309
5	2 bytes	Fifth Wheel Roll Moment	3310
7.1	2 bits	Fifth Wheel Roll Warning Indicator	3317

PGN 61459**Slope Sensor Information****- SSI**

The Slope Sensor Information message shall provide a measurement of the vehicles pitch angle, a measurement of the vehicles roll angle, and a measurement of the vehicles pitch rate around the y-axis.

Vehicle axis system defined in SAE J670e, Vehicle Dynamics Terminology.

8.4.7 Vehicle Roll Angle – The angle between the vehicle y-axis and the ground plane.

8.4.9 Vehicle Pitch Angle – The angle between the vehicle x-axis and the ground plane.

Note 6

"Angular rotations are positive clockwise when looking in the positive direction of the axis about which rotation occurs."

The data within the message shall contain the measured pitch, roll, and pitch rate, figure of merits for the three measurements, a compensated measurement indicator, and measurement latency for the sensor measurements.

Note 1) When this PGN is used to transmit information from a device not attached to the vehicle, the components local frame of reference shall be used.

Note 2) The NAME of the source of the PGN shall to used to associate to the frame of reference. (e.g, Machine control will report vehicle pitch and roll, blade control will report blade pitch and roll).

Transmission Repetition Rate: 10 ms
 Data Length: 8
 Extended Data Page: 0
 Data Page: 0
 PDU Format: 240
 PDU Specific: 19 PGN Supporting Information: See Appendix D - PGN 61459
 Default Priority: 3
 Parameter Group Number: 61459 (0xF013)

Start Position	Length	Parameter Name	SPN
1	2 bytes	Pitch Angle	3318
3	2 bytes	Roll Angle	3319
5	2 bytes	Pitch Rate	3322
7.1	2 bits	Pitch Angle Figure of Merit	3323
7.3	2 bits	Roll Angle Figure of Merit	3324
7.5	2 bits	Pitch Rate Figure of Merit	3325
7.7	2 bits	Pitch and Roll Compensated	3326
8	1 byte	Roll and Pitch Measurement Latency	3327

PGN 61460**Blade Information****- BI**

A measurement of the machine's relative blade height and a rotational angle measurement of the machine blade yaw angle around the machine z-axis as defined in SAE J670e, Vehicle Dynamics Terminology.

The Relative Blade Height is defined to be the relative vertical distance from a fixed location on the machine blade to a reference. The reference might be, for example, the ground or a stringline.

The data in the message is intended to be accurate enough for real-time control.

SAE J670e, Note 6

"Angular rotations are positive clockwise when looking in the positive direction of the axis about which rotation occurs."

The Blade Rotation Angle is defined to be the angle from the null position on the machine. The null position is orthogonal from the z-axis along the x-axis.

The data within the message shall contain the measured Relative Blade Height, the measured Blade Rotation Angle, a figure of merit for the Relative Blade Height, a figure of merit for the Blade Rotation Angle, and an estimated measurement latency.

Transmission Repetition Rate: 50 ms
 Data Length: 8
 Extended Data Page: 0
 Data Page: 0
 PDU Format: 240
 PDU Specific: 20 PGN Supporting Information:
 Default Priority: 3
 Parameter Group Number: 61460 (0xF014)

Start Position	Length	Parameter Name	SPN
1-2	2 bytes	Relative Blade Height	3365
3-4	2 bytes	Blade Rotation Angle	3331
5	1 byte	Relative Blade Height and Blade Rotation Angle Measurement Latency	3366
6.1	2 bits	Relative Blade Height Figure of Merit	3367
6.3	2 bits	Blade Rotation Angle Figure of Merit	3332

PGN 61462**Cylinder Combustion Status****- CCS**

Used to send the SPNs containing information relating to the state of combustion for 24 cylinders. When there is no combustion detected on any one cylinder, this PGN needs to be sent every crank revolution (engine speed dependant). If combustion is good on all cylinders, 5 seconds would be satisfactory for a transmission rate. This will allow communication between a separate module monitoring combustion inside the engine cylinders and the control module that needs this information to make engine related decisions.

Transmission Repetition Rate: Engine speed dependent when there is no combustion, once every 5 seconds otherwise
 Data Length: 8
 Extended Data Page: 0
 Data Page: 0
 PDU Format: 240
 PDU Specific: 22 PGN Supporting Information:
 Default Priority: 3
 Parameter Group Number: 61462 (0xF016)

Start Position	Length	Parameter Name	SPN
1.1	2 bits	Engine Cylinder 1 Combustion Status	3387
1.3	2 bits	Engine Cylinder 2 Combustion Status	3388
1.5	2 bits	Engine Cylinder 3 Combustion Status	3389
1.7	2 bits	Engine Cylinder 4 Combustion Status	3390
2.1	2 bits	Engine Cylinder 5 Combustion Status	3391
2.3	2 bits	Engine Cylinder 6 Combustion Status	3392
2.5	2 bits	Engine Cylinder 7 Combustion Status	3393
2.7	2 bits	Engine Cylinder 8 Combustion Status	3394
3.1	2 bits	Engine Cylinder 9 Combustion Status	3395
3.3	2 bits	Engine Cylinder 10 Combustion Status	3396
3.5	2 bits	Engine Cylinder 11 Combustion Status	3397
3.7	2 bits	Engine Cylinder 12 Combustion Status	3398
4.1	2 bits	Engine Cylinder 13 Combustion Status	3399
4.3	2 bits	Engine Cylinder 14 Combustion Status	3400
4.5	2 bits	Engine Cylinder 15 Combustion Status	3401
4.7	2 bits	Engine Cylinder 16 Combustion Status	3402
5.1	2 bits	Engine Cylinder 17 Combustion Status	3403
5.3	2 bits	Engine Cylinder 18 Combustion Status	3404
5.5	2 bits	Engine Cylinder 19 Combustion Status	3405
5.7	2 bits	Engine Cylinder 20 Combustion Status	3406
6.1	2 bits	Engine Cylinder 21 Combustion Status	3407
6.3	2 bits	Engine Cylinder 22 Combustion Status	3408
6.5	2 bits	Engine Cylinder 23 Combustion Status	3409
6.7	2 bits	Engine Cylinder 24 Combustion Status	3410

PGN 61463**Engine Knock Level #1****- KL1**

Used to send the SPNs containing information relating to the level of knock for 8 cylinders. When knock is detected on any one cylinder, this PGN needs to be sent every crank revolution (engine speed dependant). If there is no knock detected on any cylinder, 5 seconds would be satisfactory for a transmission rate. This will allow communication between a separate module monitoring combustion inside the engine cylinders and the control module that needs this information to make engine related decisions.

Transmission Repetition Rate: Engine speed dependent when knock present, once every 5 seconds otherwise
 Data Length: 8
 Extended Data Page: 0
 Data Page: 0
 PDU Format: 240
 PDU Specific: 23 PGN Supporting Information:
 Default Priority: 3
 Parameter Group Number: 61463 (0xF017)

Start Position	Length	Parameter Name	SPN
1	1 byte	Engine Cylinder 1 Knock Level	1352
2	1 byte	Engine Cylinder 2 Knock Level	1353
3	1 byte	Engine Cylinder 3 Knock Level	1354
4	1 byte	Engine Cylinder 4 Knock Level	1355
5	1 byte	Engine Cylinder 5 Knock Level	1356
6	1 byte	Engine Cylinder 6 Knock Level	1357
7	1 byte	Engine Cylinder 7 Knock Level	1358
8	1 byte	Engine Cylinder 8 Knock Level	1359

PGN 61464**Engine Knock Level #2****- KL2**

Used to send the SPNs containing information relating to the level of knock for 8 cylinders. When knock is detected on any one cylinder, this PGN needs to be sent every crank revolution (engine speed dependant). If there is no knock detected on any cylinder, 5 seconds would be satisfactory for a transmission rate. This will allow communication between a separate module monitoring combustion inside the engine cylinders and the control module that needs this information to make engine related decisions.

Transmission Repetition Rate: Engine speed dependent when knock present, once every 5 seconds otherwise
 Data Length: 8
 Extended Data Page: 0
 Data Page: 0
 PDU Format: 240
 PDU Specific: 24 PGN Supporting Information:
 Default Priority: 3
 Parameter Group Number: 61464 (0xF018)

Start Position	Length	Parameter Name	SPN
1	1 byte	Engine Cylinder 9 Knock Level	1360
2	1 byte	Engine Cylinder 10 Knock Level	1361
3	1 byte	Engine Cylinder 11 Knock Level	1362
4	1 byte	Engine Cylinder 12 Knock Level	1363
5	1 byte	Engine Cylinder 13 Knock Level	1364
6	1 byte	Engine Cylinder 14 Knock Level	1365
7	1 byte	Engine Cylinder 15 Knock Level	1366
8	1 byte	Engine Cylinder 16 Knock Level	1367

PGN 61465 Engine Knock Level #3 - KL3

Used to send the SPNs containing information relating to the level of knock for 8 cylinders. When knock is detected on any one cylinder, this PGN needs to be sent every crank revolution (engine speed dependant). If there is no knock detected on any cylinder, 5 seconds would be satisfactory for a transmission rate. This will allow communication between a separate module monitoring combustion inside the engine cylinders and the control module that needs this information to make engine related decisions.

Transmission Repetition Rate: Engine speed dependent when knock present, once every 5 seconds otherwise
 Data Length: 8
 Extended Data Page: 0
 Data Page: 0
 PDU Format: 240
 PDU Specific: 25 PGN Supporting Information:
 Default Priority: 3
 Parameter Group Number: 61465 (0xF019)

Start Position	Length	Parameter Name	SPN
1	1 byte	Engine Cylinder 17 Knock Level	1368
2	1 byte	Engine Cylinder 18 Knock Level	1369
3	1 byte	Engine Cylinder 19 Knock Level	1370
4	1 byte	Engine Cylinder 20 Knock Level	1371
5	1 byte	Engine Cylinder 21 Knock Level	1372
6	1 byte	Engine Cylinder 22 Knock Level	1373
7	1 byte	Engine Cylinder 23 Knock Level	1374
8	1 byte	Engine Cylinder 24 Knock Level	1375

PGN 61466 Engine Throttle / Fuel Actuator Control Command - TFAC

Used to control networked electronic throttle control actuator and/or fuel control actuator valves. Otherwise, this PGN can be used to monitor commanded % positioning to electronic throttle control actuator and/or fuel control actuator valves.

Transmission Repetition Rate: 50 ms
 Data Length: 8
 Extended Data Page: 0
 Data Page: 0
 PDU Format: 240
 PDU Specific: 26 PGN Supporting Information: See Appendix D - PGN 61466
 Default Priority: 4
 Parameter Group Number: 61466 (0xF01A)

Start Position	Length	Parameter Name	SPN
1-2	2 bytes	Engine Throttle Actuator 1 Control Command	3464
3-4	2 bytes	Engine Throttle Actuator 2 Control Command	3465
5-6	2 bytes	Engine Fuel Actuator 1 Control Command	633
7-8	2 bytes	Engine Fuel Actuator 2 Control Command	1244

PGN 61469 Steering Angle Sensor Information**- SAS**

Contains information which relates to a steering angle sensor.

Transmission Repetition Rate: 10 ms
 Data Length: 8
 Extended Data Page: 0
 Data Page: 0
 PDU Format: 240
 PDU Specific: 29 PGN Supporting Information:
 Default Priority: 6
 Parameter Group Number: 61469 (0xF01D)

Start Position	Length	Parameter Name	SPN
1-2	2 bytes	Steering Wheel Angle	3683
3.1	6 bits	Steering Wheel Angle Range Counter	3684
3.7	2 bits	Steering Wheel Angle Range Counter Type	3685
5-6	2 bytes	Steering Wheel Angle Range	3686
7.1	2 bits	Steering Angle Sensor Active Mode	3687
7.3	2 bits	Steering Angle Sensor Calibrated	3688
8.1	4 bits	Message Counter	3689
8.5	4 bits	Message Checksum	3690

PGN 61473 (R) Engine Speed Sensor Information**- ESSI**

This PGN contains the speed information and status signal of each engine speed sensor. This message is used for service to troubleshoot no-start or hard start problems. This message is not needed except for servicing.

Transmission Repetition Rate: Transmitted only after requested. After request, broadcast rate is engine speed dependent. Update stopped after key switch cycle.
 Data Length: 8
 Extended Data Page: 0
 Data Page: 0
 PDU Format: 240
 PDU Specific: 32 PGN Supporting Information:
 Default Priority: 6
 Parameter Group Number: 61473 (0xF021)

Start Position	Length	Parameter Name	SPN
1-2	2 bytes	Engine Speed 1	4201
3-4	2 bytes	Engine Speed 2	723
5-6	2 bytes	Engine Speed 3	4202
7.3	2 bits	Engine Speed Sensor 3 Timing Pattern Status	4205
7.5	2 bits	Engine Speed Sensor 2 Timing Pattern Status	4204
7.7	2 bits	Engine Speed Sensor 1 Timing Pattern Status	4203

PGN 64839 (R) Transmission Mode Labels**- TML**

ASCII text string describing a manufacturer-specific Transmission Mode.

NOTE – ASCII control characters are not allowed, and the ASCII character “*” is reserved as a delimiter

Transmission Repetition Rate: On request

Data Length: Variable

Extended Data Page: 0

Data Page: 0

PDU Format: 253

PDU Specific: 71 PGN Supporting Information: See Appendix D - PGN 64839

Default Priority: 7

Parameter Group Number: 64839 (0xFD47)

Start Position	Length	Parameter Name	SPN
A	25 bytes	Transmission Mode Label	4254

PGN 64840 (R) Engine Exhaust Bank 2 O2 Fuel Trim**- O2FT2**

Provides bank 2 short-term and long-term fuel trim values

Transmission Repetition Rate: On Request

Data Length: 8

Extended Data Page: 0

Data Page: 0

PDU Format: 253

PDU Specific: 72 PGN Supporting Information:

Default Priority: 6

Parameter Group Number: 64840 (0xFD48)

Start Position	Length	Parameter Name	SPN
1-2	16 bits	Long-term fuel trim - bank 2	4239
3-4	16 bits	Short-term fuel trim - bank 2	4238
5.1	4 bits	Engine Exhaust Gas Oxygen Sensor Closed Loop Operation, bank 2	4241

PGN 64841 (R) Engine Exhaust Bank 1 O2 Fuel Trim**- O2FT1**

Provides bank 1 short-term and long-term fuel trim values

Transmission Repetition Rate: On Request
 Data Length: 8
 Extended Data Page: 0
 Data Page: 0
 PDU Format: 253
 PDU Specific: 73 PGN Supporting Information:
 Default Priority: 6
 Parameter Group Number: 64841 (0xFD49)

Start Position	Length	Parameter Name	SPN
1-2	16 bits	Long-term fuel trim - bank 1	4237
3-4	16 bits	Short-term fuel trim - bank 1	4236
5.1	4 bits	Engine Exhaust Gas Oxygen Sensor Closed Loop Operation, bank 1	4240

PGN 64849 (R) Aftercooler Coolant Control Valve Command**- ACCVC**

Transmit status information from the Master ECU to an electronic thermostat

Transmission Repetition Rate: 1 sec
 Data Length: 8 bytes
 Extended Data Page: 0
 Data Page: 0
 PDU Format: 253
 PDU Specific: 81 PGN Supporting Information:
 Default Priority: 4
 Parameter Group Number: 64849 (0xFD51)

Start Position	Length	Parameter Name	SPN
1.1	2 bits	Aftercooler Coolant Thermostat Mode	4198
2	1 byte	Desired Aftercooler Coolant Inlet Temperature	4199
3	1 byte	Desired Aftercooler Coolant Thermostat Opening	4200

PGN 64850 (R) Engine Coolant Control Valve Command**- ECCVC**

Transmit status information from the Master ECU to an electronic thermostat

Transmission Repetition Rate: 1 sec
 Data Length: 8 bytes
 Extended Data Page: 0
 Data Page: 0
 PDU Format: 253
 PDU Specific: 82 PGN Supporting Information:
 Default Priority: 4
 Parameter Group Number: 64850 (0xFD52)

Start Position	Length	Parameter Name	SPN
1.1	2 bits	Engine Coolant Thermostat Mode	4195
2	1 byte	Desired Engine Coolant Pump Outlet Temperature	4196
3	1 byte	Desired Engine Coolant Thermostat Opening	4197

PGN 64851 (R) Engine Average Information**- EAI**

Reports averaged engine information

Transmission Repetition Rate: 500 ms
 Data Length: 8
 Extended Data Page: 0
 Data Page: 0
 PDU Format: 253
 PDU Specific: 83 PGN Supporting Information:
 Default Priority: 5
 Parameter Group Number: 64851 (0xFD53)

Start Position	Length	Parameter Name	SPN
1-2	2 bytes	Engine Exhaust Gas Temperature Average	4151
3-4	2 bytes	Engine Exhaust Gas Temperature Average - Bank 1	4153
5-6	2 bytes	Engine Exhaust Gas Temperature Average - Bank 2	4152

PGN 64869**Aftertreatment 1 Fuel Control 2****- AT1FC2**

Contains information about the aftertreatment 1 fuel system. See also PGN 64929.

Transmission Repetition Rate: 500 ms
 Data Length: 8
 Extended Data Page: 0
 Data Page: 0
 PDU Format: 253
 PDU Specific: 101 PGN Supporting Information:
 Default Priority: 6
 Parameter Group Number: 64869 (0xFD65)

Start Position	Length	Parameter Name	SPN
1-2	2 bytes	Aftertreatment 1 Fuel Pressure 2	4077

PGN 64870 (R) Engine Temperature 4**- ET4**

Engine temperatures

Transmission Repetition Rate: 1 s
 Data Length: 8
 Extended Data Page: 0
 Data Page: 0
 PDU Format: 253
 PDU Specific: 102 PGN Supporting Information:
 Default Priority: 6
 Parameter Group Number: 64870 (0xFD66)

Start Position	Length	Parameter Name	SPN
1	1 byte	Engine Coolant Temperature 2	4076
2	1 byte	Engine Coolant Pump Outlet Temperature	4193
3	1 byte	Engine Coolant Thermostat Opening	4194

PGN 64871 Zero Net Vehicle Weight Change**- ZNVW**

Zero Net Vehicle Weight Change

Transmission Repetition Rate: As needed
 Data Length: 8
 Extended Data Page: 0
 Data Page: 0
 PDU Format: 253
 PDU Specific: 103 PGN Supporting Information:
 Default Priority: 6
 Parameter Group Number: 64871 (0xFD67)

Start Position	Length	Parameter Name	SPN
1.1	2 bits	Zero Net Vehicle Weight Change	4075

PGN 64872 Gross Combination Vehicle Weight - GCVW

Gross Combination Vehicle Weight

Transmission Repetition Rate: On request

Data Length: 8

Extended Data Page: 0

Data Page: 0

PDU Format: 253

PDU Specific: 104 PGN Supporting Information:

Default Priority: 5

Parameter Group Number: 64872 (0xFD68)

Start Position	Length	Parameter Name	SPN
1-3	3 bytes	Gross Combination Weight	417
4-6	3 bytes	Net Vehicle Weight Change	413

PGN 64873 Axle Group Calibration Weights - AGCW

Indicates axle group calibration weights

Transmission Repetition Rate: On request. Upon request, will be broadcast an many times as required to transmit all available axle groups.

Data Length: 8

Extended Data Page: 0

Data Page: 0

PDU Format: 253

PDU Specific: 105 PGN Supporting Information:

Default Priority: 7

Parameter Group Number: 64873 (0xFD69)

Start Position	Length	Parameter Name	SPN
1.1	4 bits	Axle Group Location	4074
2-3	2 bytes	Axle Group Empty Weight Calibration	408
4-5	2 bytes	Axle Group Full Weight Calibration	407

PGN 64874**Axle Group Weight****- AGW**

Combination of specific axle group and the weight imposed on that axle group

Transmission Repetition Rate: On request. Upon request, will be broadcast an many times as required to transmit all available axle groups.

Data Length: 8
 Extended Data Page: 0
 Data Page: 0
 PDU Format: 253
 PDU Specific: 106 PGN Supporting Information:
 Default Priority: 5
 Parameter Group Number: 64874 (0xFD6A)

Start Position	Length	Parameter Name	SPN
1.1	4 bits	Axle Group Location	4073
2-3	2 bytes	Axle Group Weight	409

PGN 64875**Available Axle Group Weights****- AAGW**

Indicates which axle groups are included in the current weight calculation

Transmission Repetition Rate: As needed. Broadcast whenever an axle group equipped with an on-board scale joined or left the on-board scale subset.

Data Length: 8
 Extended Data Page: 0
 Data Page: 0
 PDU Format: 253
 PDU Specific: 107 PGN Supporting Information:
 Default Priority: 6
 Parameter Group Number: 64875 (0xFD6B)

Start Position	Length	Parameter Name	SPN
1.1	2 bits	Steer Axle Group Weight Available	4059
1.3	2 bits	Lift Axle Group Weight Available	4060
1.5	2 bits	Drive Axle Group Weight Available	4061
1.7	2 bits	Tag Axle Group Weight Available	4062
2.1	2 bits	Additional Tractor Axle Group Weight Available	4063
2.3	2 bits	Trailer A Axle Group Weight Available	4064
2.5	2 bits	Trailer B Axle Group Weight Available	4065
2.7	2 bits	Trailer C Axle Group Weight Available	4066
3.1	2 bits	Trailer D Axle Group Weight Available	4067
3.3	2 bits	Trailer E Axle Group Weight Available	4068
3.5	2 bits	Trailer F Axle Group Weight Available	4069
3.7	2 bits	Trailer G Axle Group Weight Available	4070
4.1	2 bits	Trailer H Axle Group Weight Available	4071
4.3	2 bits	Additional Trailer Axle Group Weight Available	4072

PGN 64876**Aftertreatment 2 Air Control 2****- AT2AC2**

This PGN contains information about the Aftertreatment 2 Air Control.

NOTE: This message will be transmitted by the engine or aftertreatment controller. Other aftertreatment air control information could be added in the future.

Transmission Repetition Rate: 500 msec
 Data Length: 8
 Extended Data Page: 0
 Data Page: 0
 PDU Format: 253
 PDU Specific: 108 PGN Supporting Information:
 Default Priority: 6
 Parameter Group Number: 64876 (0xFD6C)

Start Position	Length	Parameter Name	SPN
1-2	2 bytes	Aftertreatment 2 Secondary Air Differential Pressure	3833
3-4	2 bytes	Aftertreatment 2 Secondary Air Temperature	3834
5-6	2 bytes	Aftertreatment 2 Secondary Air Mass Flow	3835
7-8	2 bytes	Aftertreatment 2 Secondary Air Pressure	3838

PGN 64877**Aftertreatment 1 Air Control 2****- AT1AC2**

This PGN contains information about the Aftertreatment 1 Air Control.

NOTE: This message will be transmitted by the engine or aftertreatment controller. Other aftertreatment air control information could be added in the future.

Transmission Repetition Rate: 500 msec
 Data Length: 8
 Extended Data Page: 0
 Data Page: 0
 PDU Format: 253
 PDU Specific: 109 PGN Supporting Information:
 Default Priority: 6
 Parameter Group Number: 64877 (0xFD6D)

Start Position	Length	Parameter Name	SPN
1-2	2 bytes	Aftertreatment 1 Secondary Air Differential Pressure	3830
3-4	2 bytes	Aftertreatment 1 Secondary Air Temperature	3831
5-6	2 bytes	Aftertreatment 1 Secondary Air Mass Flow	3832
7-8	2 bytes	Aftertreatment 1 Secondary Air Pressure	3837

PGN 64878**Catalyst Use Information****- SCR1**

Used to provide information to an inspection tool regarding the proper use of reagent in SCR type emissions control systems.

Transmission Repetition Rate: On request
 Data Length: 8
 Extended Data Page: 0
 Data Page: 0
 PDU Format: 253
 PDU Specific: 110 PGN Supporting Information:
 Default Priority: 6
 Parameter Group Number: 64878 (0xFD6E)

Start Position	Length	Parameter Name	SPN
1-2	2 bytes	Average Catalyst Reagent Consumption	3826
3-4	2 bytes	Commanded Catalyst Reagent Consumption	3828

PGN 64879**Electronic Engine Controller 8****- EEC8**

Engine related parameters

Transmission Repetition Rate: On request
 Data Length: 8
 Extended Data Page: 0
 Data Page: 0
 PDU Format: 253
 PDU Specific: 111 PGN Supporting Information:
 Default Priority: 6
 Parameter Group Number: 64879 (0xFD6F)

Start Position	Length	Parameter Name	SPN
1	2 bytes	Engine Exhaust Gas Recirculation (EGR) Valve 2 Control	3821

PGN 64880**Door ramp control****- DRC**

This message reports the current status of door ramps

Transmission Repetition Rate: 1 s when active and on change of state
 Data Length: 8
 Extended Data Page: 0
 Data Page: 0
 PDU Format: 253
 PDU Specific: 112 PGN Supporting Information:
 Default Priority: 6
 Parameter Group Number: 64880 (0xFD70)

Start Position	Length	Parameter Name	SPN
1.1	2 bits	Retract Status of ramp 1	3810
1.3	2 bits	Enable status of ramp 1	3811
1.5	2 bits	Movement status of ramp 1	3812
2.1	2 bits	Retract Status of ramp 2	3813
2.3	2 bits	Enable status of ramp 2	3814
2.5	2 bits	Movement status of ramp 2	3815
3.1	2 bits	Retract Status of ramp 3	3816
3.3	2 bits	Enable status of ramp 3	3817
3.5	2 bits	Movement status of ramp 3	3818

PGN 64881**Brake actuator stroke status****- BSA**

The Brake Stroke Alert (BSA) message will provide the brake actuator stroke status for up to 20 wheel ends.

Transmission Repetition Rate: 1 sec
 Data Length: 8
 Extended Data Page: 0
 Data Page: 0
 PDU Format: 253
 PDU Specific: 113 PGN Supporting Information:
 Default Priority: 6
 Parameter Group Number: 64881 (0xFD71)

Start Position	Length	Parameter Name	SPN
1.1	3 bits	Tractor Brake Stroke Axle 1 Left	3785
1.4	3 bits	Tractor Brake Stroke Axle 1 Right	3786
1.7-2.1	3 bits	Tractor Brake Stroke Axle 2 Left	3787
2.2	3 bits	Tractor Brake Stroke Axle 2 Right	3788
2.5	3 bits	Tractor Brake Stroke Axle 3 Left	3789
2.8-3.2	3 bits	Tractor Brake Stroke Axle 3 Right	3790
3.3	3 bits	Tractor Brake Stroke Axle 4 Left	3791
3.6	3 bits	Tractor Brake Stroke Axle 4 Right	3792
4.1	3 bits	Tractor Brake Stroke Axle 5 Left	3793
4.4	3 bits	Tractor Brake Stroke Axle 5 Right	3794
4.7-5.1	3 bits	Trailer Brake Stroke Axle 1 Left	3795
5.2	3 bits	Trailer Brake Stroke Axle 1 Right	3796
5.5	3 bits	Trailer Brake Stroke Axle 2 Left	3797
5.8-6.2	3 bits	Trailer Brake Stroke Axle 2 Right	3798
6.3	3 bits	Trailer Brake Stroke Axle 3 Left	3799
6.6	3 bits	Trailer Brake Stroke Axle 3 Right	3800
7.1	3 bits	Trailer Brake Stroke Axle 4 Left	3801
7.4	3 bits	Trailer Brake Stroke Axle 4 Right	3802
7.7-8.1	3 bits	Trailer Brake Stroke Axle 5 Left	3803
8.2	3 bits	Trailer Brake Stroke Axle 5 Right	3804

PGN 64882**Engine Spark Voltage 6****- ESV6**

The PGN contains information about spark voltage values for cylinders 21 through 24. This is the secondary voltage of the combustion event.

Transmission Repetition Rate: On request
 Data Length: 8
 Extended Data Page: 0
 Data Page: 0
 PDU Format: 253
 PDU Specific: 114 PGN Supporting Information:
 Default Priority: 6
 Parameter Group Number: 64882 (0xFD72)

Start Position	Length	Parameter Name	SPN
1-2	2 bytes	Engine Spark Plug 21	1314
3-4	2 bytes	Engine Spark Plug 22	1315
5-6	2 bytes	Engine Spark Plug 23	1316
7-8	2 bytes	Engine Spark Plug 24	1317

PGN 64883**Engine Spark Voltage 5****- ESV5**

The PGN contains information about spark voltage values for cylinders 17 through 20. This is the secondary voltage of the combustion event.

Transmission Repetition Rate: On request
 Data Length: 8
 Extended Data Page: 0
 Data Page: 0
 PDU Format: 253
 PDU Specific: 115 PGN Supporting Information:
 Default Priority: 6
 Parameter Group Number: 64883 (0xFD73)

Start Position	Length	Parameter Name	SPN
1-2	2 bytes	Engine Spark Plug 17	1310
3-4	2 bytes	Engine Spark Plug 18	1311
5-6	2 bytes	Engine Spark Plug 19	1312
7-8	2 bytes	Engine Spark Plug 20	1313

PGN 64884**Engine Spark Voltage 4****- ESV4**

The PGN contains information about spark voltage values for cylinders 13 through 16. This is the secondary voltage of the combustion event.

Transmission Repetition Rate: On request
 Data Length: 8
 Extended Data Page: 0
 Data Page: 0
 PDU Format: 253
 PDU Specific: 116 PGN Supporting Information:
 Default Priority: 6
 Parameter Group Number: 64884 (0xFD74)

Start Position	Length	Parameter Name	SPN
1-2	2 bytes	Engine Spark Plug 13	1306
3-4	2 bytes	Engine Spark Plug 14	1307
5-6	2 bytes	Engine Spark Plug 15	1308
7-8	2 bytes	Engine Spark Plug 16	1309

PGN 64885**Engine Spark Voltage 3****- ESV3**

The PGN contains information about spark voltage values for cylinders 9 through 12. This is the secondary voltage of the combustion event.

Transmission Repetition Rate: On request
 Data Length: 8
 Extended Data Page: 0
 Data Page: 0
 PDU Format: 253
 PDU Specific: 117 PGN Supporting Information:
 Default Priority: 6
 Parameter Group Number: 64885 (0xFD75)

Start Position	Length	Parameter Name	SPN
1-2	2 bytes	Engine Spark Plug 9	1302
3-4	2 bytes	Engine Spark Plug 10	1303
5-6	2 bytes	Engine Spark Plug 11	1304
7-8	2 bytes	Engine Spark Plug 12	1305

PGN 64886**Engine Spark Voltage 2****- ESV2**

The PGN contains information about spark voltage values for cylinders 5 through 8. This is the secondary voltage of the combustion event.

Transmission Repetition Rate: On request
 Data Length: 8
 Extended Data Page: 0
 Data Page: 0
 PDU Format: 253
 PDU Specific: 118 PGN Supporting Information:
 Default Priority: 6
 Parameter Group Number: 64886 (0xFD76)

Start Position	Length	Parameter Name	SPN
1-2	2 bytes	Engine Spark Plug 5	1298
3-4	2 bytes	Engine Spark Plug 6	1299
5-6	2 bytes	Engine Spark Plug 7	1300
7-8	2 bytes	Engine Spark Plug 8	1301

PGN 64887**Engine Spark Voltage 1****- ESV1**

The PGN contains information about spark voltage values for cylinders 1 through 4. This is the secondary voltage of the combustion event.

Transmission Repetition Rate: On request
 Data Length: 8
 Extended Data Page: 0
 Data Page: 0
 PDU Format: 253
 PDU Specific: 119 PGN Supporting Information:
 Default Priority: 6
 Parameter Group Number: 64887 (0xFD77)

Start Position	Length	Parameter Name	SPN
1-2	2 bytes	Engine Spark Plug 1	1294
3-4	2 bytes	Engine Spark Plug 2	1295
5-6	2 bytes	Engine Spark Plug 3	1296
7-8	2 bytes	Engine Spark Plug 4	1297

PGN 64888**Aftertreatment 2 Trip Information****- AT2TI**

This PGN contains trip total information about the aftertreatment 2.

NOTE: The SPNs in this PGN need to be reset by the reset PGN 56832.

Transmission Repetition Rate: On request
 Data Length: 32
 Extended Data Page: 0
 Data Page: 0
 PDU Format: 253
 PDU Specific: 120 PGN Supporting Information:
 Default Priority: 6
 Parameter Group Number: 64888 (0xFD78)

Start Position	Length	Parameter Name	SPN
01-04	4 bytes	Aftertreatment 2 Trip Fuel Used	3741
05-08	4 bytes	Aftertreatment 2 Trip Active Regeneration Time	3742
09-12	4 bytes	Aftertreatment 2 Trip Disabled Time	3743
13-16	4 bytes	Aftertreatment 2 Trip Number of Active Regenerations	3744
17-20	4 bytes	Aftertreatment 2 Trip Passive Regeneration Time	3745
21-24	4 bytes	Aftertreatment 2 Trip Number of Passive Regenerations	3746
25-28	4 bytes	Aftertreatment 2 Trip Number of Active Regeneration Inhibit Requests	3747
29-32	4 bytes	Aftertreatment 2 Trip Number of Active Regeneration Manual Requests	3748

PGN 64889**Aftertreatment 1 Trip Information****- AT1TI**

This PGN contains trip total information about the aftertreatment 1.

NOTE: The SPNs in this PGN need to be reset by the reset PGN 56832.

Transmission Repetition Rate: On request
 Data Length: 32
 Extended Data Page: 0
 Data Page: 0
 PDU Format: 253
 PDU Specific: 121 PGN Supporting Information:
 Default Priority: 6
 Parameter Group Number: 64889 (0xFD79)

Start Position	Length	Parameter Name	SPN
01-04	4 bytes	Aftertreatment 1 Trip Fuel Used	3733
05-08	4 bytes	Aftertreatment 1 Trip Active Regeneration Time	3734
09-12	4 bytes	Aftertreatment 1 Trip Disabled Time	3735
13-16	4 bytes	Aftertreatment 1 Trip Number of Active Regenerations	3736
17-20	4 bytes	Aftertreatment 1 Trip Passive Regeneration Time	3737
21-24	4 bytes	Aftertreatment 1 Trip Number of Passive Regenerations	3738
25-28	4 bytes	Aftertreatment 1 Trip Number of Active Regeneration Inhibit Requests	3739
29-32	4 bytes	Aftertreatment 1 Trip Number of Active Regeneration Manual Requests	3740

PGN 64890**Aftertreatment 2 Service****- AT2S**

This PGN contains information about the aftertreatment 2 (diesel particulate filter 2 soot and ash load).

Transmission Repetition Rate: On request
 Data Length: 8
 Extended Data Page: 0
 Data Page: 0
 PDU Format: 253
 PDU Specific: 122 PGN Supporting Information:
 Default Priority: 6
 Parameter Group Number: 64890 (0xFD7A)

Start Position	Length	Parameter Name	SPN
1	1 byte	Diesel Particulate Filter 2 Soot Load Percent	3722
2	1 byte	Diesel Particulate Filter 2 Ash Load Percent	3723
3-6	4 bytes	Diesel Particulate Filter 2 Time Since Last Active Regeneration	3724

PGN 64891**Aftertreatment 1 Service****- AT1S**

This PGN contains information about the aftertreatment 1 (diesel particulate filter 1 soot and ash load).

Transmission Repetition Rate: On request
 Data Length: 8
 Extended Data Page: 0
 Data Page: 0
 PDU Format: 253
 PDU Specific: 123 PGN Supporting Information:
 Default Priority: 6
 Parameter Group Number: 64891 (0xFD7B)

Start Position	Length	Parameter Name	SPN
1	1 byte	Diesel Particulate Filter 1 Soot Load Percent	3719
2	1 byte	Diesel Particulate Filter 1 Ash Load Percent	3720
3-6	4 bytes	Diesel Particulate Filter 1 Time Since Last Active Regeneration	3721

PGN 64892 (R) Diesel Particulate Filter Control 1**- DPFC1**

This PGN contains information about the diesel particulate filter regeneration control.

If there are aftertreatment systems on two banks, this PGN represents the composite information from both banks.

Transmission Repetition Rate: 1 s and on change
 Data Length: 8
 Extended Data Page: 0
 Data Page: 0
 PDU Format: 253
 PDU Specific: 124 PGN Supporting Information:
 Default Priority: 6
 Parameter Group Number: 64892 (0xFD7C)

Start Position	Length	Parameter Name	SPN
1.1	3 bits	Diesel Particulate Filter Lamp Command	3697
2.1	2 bits	Diesel Particulate Filter Passive Regeneration Status	3699
2.3	2 bits	Diesel Particulate Filter Active Regeneration Status	3700
2.5	3 bits	Diesel Particulate Filter Status	3701
3.1	2 bits	Diesel Particulate Filter Active Regeneration Inhibited Status	3702
3.3	2 bits	Diesel Particulate Filter Active Regeneration Inhibited Due to Inhibit Switch	3703
3.5	2 bits	Diesel Particulate Filter Active Regeneration Inhibited Due to Clutch Disengaged	3704
3.7	2 bits	Diesel Particulate Filter Active Regeneration Inhibited Due to Service Brake Active	3705
4.1	2 bits	Diesel Particulate Filter Active Regeneration Inhibited Due to PTO Active	3706
4.3	2 bits	Diesel Particulate Filter Active Regeneration Inhibited Due to Accelerator Pedal Off Idle	3707
4.5	2 bits	Diesel Particulate Filter Active Regeneration Inhibited Due to Out of Neutral	3708
4.7	2 bits	Diesel Particulate Filter Active Regeneration Inhibited Due to Vehicle Speed Above Allowed Speed	3709
5.1	2 bits	Diesel Particulate Filter Active Regeneration Inhibited Due to Parking Brake Not Set	3710
5.3	2 bits	Diesel Particulate Filter Active Regeneration Inhibited Due to Low Exhaust Gas Temperature	3711
5.5	2 bits	Diesel Particulate Filter Active Regeneration Inhibited Due to System Fault Active	3712
5.7	2 bits	Diesel Particulate Filter Active Regeneration Inhibited Due to System Timeout	3713
6.1	2 bits	Diesel Particulate Filter Active Regeneration Inhibited Due to Temporary System Lockout	3714
6.3	2 bits	Diesel Particulate Filter Active Regeneration Inhibited Due to Permanent System Lockout	3715
6.5	2 bits	Diesel Particulate Filter Active Regeneration Inhibited Due to Engine Not Warmed Up	3716
6.7	2 bits	Diesel Particulate Filter Active Regeneration Inhibited Due to Vehicle Speed Below Allowed Speed	3717
7.1	2 bits	Diesel Particulate Filter Automatic Active Regeneration Initiation Configuration	3718
7.3	3 bits	Exhaust System High Temperature Lamp Command	3698
7.6	3 bits	Diesel Particulate Filter Active Regeneration Forced Status	4175

PGN 64894**Adaptive Front-Lighting System Status****- AFSS**

This message reports information about the current operation mode of the Adaptive Front-Lighting System (AFS). The Message may include information about dynamic bending light and light distribution. The message provides feedback to the light controller and may be used to ensure a fail safe state in case of malfunction.

Transmission Repetition Rate: On request
 Data Length: 8
 Extended Data Page: 0
 Data Page: 0
 PDU Format: 253
 PDU Specific: 126 PGN Supporting Information:
 Default Priority: 6
 Parameter Group Number: 64894 (0xFD7E)

Start Position	Length	Parameter Name	SPN
1.1	3 bits	Left Headlamp Dynamic Bending Light	3691
1.4	3 bits	Right Headlamp Dynamic Bending Light	3692
2.1	4 bits	Left Headlamp Light Distribution	3693
2.5	4 bits	Right Headlamp Light Distribution	3694

PGN 64895**Engine Configuration 2****- EC2**

Contains static information about the engine. To be used with data that will not change during vehicle operation.

Transmission Repetition Rate: On request
 Data Length: 8
 Extended Data Page: 0
 Data Page: 0
 PDU Format: 253
 PDU Specific: 127 PGN Supporting Information:
 Default Priority: 6
 Parameter Group Number: 64895 (0xFD7F)

Start Position	Length	Parameter Name	SPN
1	1 byte	Maximum Crank Attempts per Start Attempt	3670

PGN 64897**EGR Cooler Bypass****- EGRBV**

Contains information about the EGR Cooler Bypass

Transmission Repetition Rate: 500 ms
 Data Length: 8
 Extended Data Page: 0
 Data Page: 0
 PDU Format: 253
 PDU Specific: 129 PGN Supporting Information:
 Default Priority: 5
 Parameter Group Number: 64897 (0xFD81)

Start Position	Length	Parameter Name	SPN
1	1 byte	EGR Cooler Bypass Actuator Postion	3672

PGN 64899**Transfer Case Information****- TCI**

Transfer Case Information

Transmission Repetition Rate: 1 s or on change
 Data Length: 8
 Extended Data Page: 0
 Data Page: 0
 PDU Format: 253
 PDU Specific: 131 PGN Supporting Information:
 Default Priority: 6
 Parameter Group Number: 64899 (0xFD83)

Start Position	Length	Parameter Name	SPN
1.1	3 bits	Transfer case status	3643

PGN 64900**Engine Fluid Level/Pressure 9****- EFL/P9**

This message contains Engine Intake Valve Actuation Oil Pressure information.

Transmission Repetition Rate: 500 ms
 Data Length: 8
 Extended Data Page: 0
 Data Page: 0
 PDU Format: 253
 PDU Specific: 132 PGN Supporting Information:
 Default Priority: 6
 Parameter Group Number: 64900 (0xFD84)

Start Position	Length	Parameter Name	SPN
1-2	2 bytes	Engine Intake Valve Actuation Oil Pressure for Cylinder #17	3640
3-4	2 bytes	Engine Intake Valve Actuation Oil Pressure for Cylinder #18	3641
5-6	2 bytes	Engine Intake Valve Actuation Oil Pressure for Cylinder #19	3642
7-8	2 bytes	Engine Intake Valve Actuation Oil Pressure for Cylinder #20	3643

PGN 64901**Engine Fluid Level/Pressure 8****- EFL/P8**

This message contains Engine Intake Valve Actuation Oil Pressure information.

Transmission Repetition Rate: 500 ms
 Data Length: 8
 Extended Data Page: 0
 Data Page: 0
 PDU Format: 253
 PDU Specific: 133 PGN Supporting Information:
 Default Priority: 6
 Parameter Group Number: 64901 (0xFD85)

Start Position	Length	Parameter Name	SPN
1-2	2 bytes	Engine Intake Valve Actuation Oil Pressure for Cylinder #13	3636
3-4	2 bytes	Engine Intake Valve Actuation Oil Pressure for Cylinder #14	3637
5-6	2 bytes	Engine Intake Valve Actuation Oil Pressure for Cylinder #15	3638
7-8	2 bytes	Engine Intake Valve Actuation Oil Pressure for Cylinder #16	3639

PGN 64902**Engine Fluid Level/Pressure 7****- EFL/P7**

This message contains Engine Intake Valve Actuation Oil Pressure information.

Transmission Repetition Rate: 500 ms
 Data Length: 8
 Extended Data Page: 0
 Data Page: 0
 PDU Format: 253
 PDU Specific: 134 PGN Supporting Information:
 Default Priority: 6
 Parameter Group Number: 64902 (0xFD86)

Start Position	Length	Parameter Name	SPN
1-2	2 bytes	Engine Intake Valve Actuation Oil Pressure for Cylinder #9	3632
3-4	2 bytes	Engine Intake Valve Actuation Oil Pressure for Cylinder #10	3633
5-6	2 bytes	Engine Intake Valve Actuation Oil Pressure for Cylinder #11	3634
7-8	2 bytes	Engine Intake Valve Actuation Oil Pressure for Cylinder #12	3635

PGN 64903**Engine Fluid Level/Pressure 6****- EFL/P6**

This message contains Engine Intake Valve Actuation Oil Pressure information.

Transmission Repetition Rate: 500 ms
 Data Length: 8
 Extended Data Page: 0
 Data Page: 0
 PDU Format: 253
 PDU Specific: 135 PGN Supporting Information:
 Default Priority: 6
 Parameter Group Number: 64903 (0xFD87)

Start Position	Length	Parameter Name	SPN
1-2	2 bytes	Engine Intake Valve Actuation Oil Pressure for Cylinder #5	3628
3-4	2 bytes	Engine Intake Valve Actuation Oil Pressure for Cylinder #6	3629
5-6	2 bytes	Engine Intake Valve Actuation Oil Pressure for Cylinder #7	3630
7-8	2 bytes	Engine Intake Valve Actuation Oil Pressure for Cylinder #8	3631

PGN 64904**Engine Fluid Level/Pressure 5****- EFL/P5**

This message contains Engine Intake Valve Actuation Oil Pressure information.

Transmission Repetition Rate: 500 ms
 Data Length: 8
 Extended Data Page: 0
 Data Page: 0
 PDU Format: 253
 PDU Specific: 136 PGN Supporting Information:
 Default Priority: 6
 Parameter Group Number: 64904 (0xFD88)

Start Position	Length	Parameter Name	SPN
1-2	2 bytes	Engine Intake Valve Actuation Oil Pressure for Cylinder #1	3624
3-4	2 bytes	Engine Intake Valve Actuation Oil Pressure for Cylinder #2	3625
5-6	2 bytes	Engine Intake Valve Actuation Oil Pressure for Cylinder #3	3626
7-8	2 bytes	Engine Intake Valve Actuation Oil Pressure for Cylinder #4	3627

PGN 64905**Vehicle Direction/Speed 2****- VDS2**

Vehicle Direction/Speed 2 PGN contains the vehicle roll data.

Transmission Repetition Rate: On request
 Data Length: 8
 Extended Data Page: 0
 Data Page: 0
 PDU Format: 253
 PDU Specific: 137 PGN Supporting Information:
 Default Priority: 6
 Parameter Group Number: 64905 (0xFD89)

Start Position	Length	Parameter Name	SPN
1-2	2 bytes	Vehicle Roll	3623

PGN 64906**SAE J2012 DTC Display****- J2012**

Conveys basic SAE J2012 DTC information for on-board or service tool displays.

If PGN 64906 is requested and a supporting device has no active or inactive J2012 DTCs, PGN 64906 shall be sent with the first data byte (Number of J2012 DTCs) set to zero. Any unused bytes in the PGN shall be set to 255. When two or more J2012 DTCs are indicated PGN 64906 must be sent via Transport Protocol (See J1939-21).

See supporting information for data byte arrangement and example.

Transmission Repetition Rate: On request
 Data Length: Variable
 Extended Data Page: 0
 Data Page: 0
 PDU Format: 253
 PDU Specific: 138 PGN Supporting Information: See Appendix D - PGN 64906
 Default Priority: 7
 Parameter Group Number: 64906 (0xFD8A)

Start Position	Length	Parameter Name	SPN
1	1 byte	Number of J2012 DTCs	3619
2-6	5 bytes	J2012 DTC	3620
7.1	1 bit	J2012 DTC Status	3621
7.2	7 bits	J2012 DTC Occurrence Count	3622

PGN 64907**Aftertreatment 2 Gas Parameters****- AT2GP**

Diesel particulate filter gas parameters for system or bank 2

Transmission Repetition Rate: 500 ms
 Data Length: 8
 Extended Data Page: 0
 Data Page: 0
 PDU Format: 253
 PDU Specific: 139 PGN Supporting Information:
 Default Priority: 6
 Parameter Group Number: 64907 (0xFD8B)

Start Position	Length	Parameter Name	SPN
1-2	2 bytes	Diesel Particulate Filter Intake Pressure 2	3611
3-4	2 bytes	Diesel Particulate Filter Outlet Pressure 2	3612

PGN 64908**Aftertreatment 1 Gas Parameters****- AT1GP**

Diesel particulate filter gas parameters for system or bank 1

Transmission Repetition Rate: 500 ms
 Data Length: 8
 Extended Data Page: 0
 Data Page: 0
 PDU Format: 253
 PDU Specific: 140 PGN Supporting Information:
 Default Priority: 6
 Parameter Group Number: 64908 (0xFD8C)

Start Position	Length	Parameter Name	SPN
1-2	2 bytes	Diesel Particulate Filter Intake Pressure 1	3609
3-4	2 bytes	Diesel Particulate Filter Outlet Pressure 1	3610

PGN 64912**Advertised Engine Torque Curve****- AETC**

This message conveys the advertised torque curve for the engine, as typically seen on specification sheets available from most engine manufacturers. The collection conditions for the data conveyed are indicated by SPN 3558 – AETC Data Collection Standard.

This map does not contain dynamic elements, and does not change during engine operation. For engines capable of dynamically switching between torque curves or ratings during operation, this map contains values for the highest (most powerful) rating. This map is not intended for use in real time engine control, but merely to indicate what engine rating is installed in the vehicle.

Data points on the curve are in order from left to right, and, at a minimum, must span from the lowest rpm where peak torque can be produced to the high speed governor breakpoint. SPN 3559 – Number of AETC Data Points indicates the number of data point pairs being sent. A minimum of 5 points must be supported, with up to 15 available as needed to properly convey the shape of the torque curve. Speed values need not be evenly incremented.

The pair of data points (a and b) are repeated in the PGN for the number of data points identified in byte 1.

Transmission Repetition Rate: On request
 Data Length: Variable
 Extended Data Page: 0
 Data Page: 0
 PDU Format: 253
 PDU Specific: 144 PGN Supporting Information: See Appendix D - PGN 64912
 Default Priority: 6
 Parameter Group Number: 64912 (0xFD90)

Start Position	Length	Parameter Name	SPN
1.1	4 bits	AETC Data Collection Standard	3558
1.5	4 bits	Number of AETC data points	3559
a	2 bytes	AETC Speed Value	3560
b	2 bytes	AETC Torque value	3561

PGN 64914 Engine Operating Information**- EOI**

Contains engine parameters related to operation.

Transmission Repetition Rate: 250 ms
 Data Length: 8
 Extended Data Page: 0
 Data Page: 0
 PDU Format: 253
 PDU Specific: 146 PGN Supporting Information:
 Default Priority: 3
 Parameter Group Number: 64914 (0xFD92)

Start Position	Length	Parameter Name	SPN
1.1	4 bits	Engine Operating State	3543
1.5	2 bits	Fuel Pump Primer Control	4082
2-3	2 bytes	Time Remaining in Engine Operating State	3544
4.1	2 bits	Engine Fuel Shutoff Vent Control	3608
4.3	2 bits	Engine Fuel Shutoff 1 Control	632
4.5	2 bits	Engine Fuel Shutoff 2 Control	2807
4.7	2 bits	Engine Fuel Shutoff Valve Leak Test Control	3601
5.1	2 bits	Engine Oil Priming Pump Control	3589
5.3	2 bits	Engine Oil Pre-heater Control	3602
5.5	2 bits	Engine Electrical System Power Conservation Control	3603
5.7	2 bits	Engine Block / Coolant Pre-heater Control	3604
6.1	2 bits	Engine Coolant Circulating Pump Control	3605
6.3	2 bits	Engine Controlled Shutdown Request	3606
6.5	2 bits	Engine Emergency (Immediate) Shutdown Indication	3607
8	1 byte	Engine Derate Request	3644

PGN 64916 Electronic Engine Controller 7**- EEC7**

Engine related parameters

Transmission Repetition Rate: 100 ms
 Data Length: 8
 Extended Data Page: 0
 Data Page: 0
 PDU Format: 253
 PDU Specific: 148 PGN Supporting Information:
 Default Priority: 6
 Parameter Group Number: 64916 (0xFD94)

Start Position	Length	Parameter Name	SPN
1	2 bytes	Engine Exhaust Gas Recirculation Valve Position	27
3	2 bytes	Engine Exhaust Gas Recirculation Valve 2 Position	3822

PGN 64917 (R) Transmission Fluids 2**- TRF2**

Transmission Repetition Rate: 1 s
Data Length: 8
Extended Data Page: 0
Data Page: 0
PDU Format: 253
PDU Specific: 149 PGN Supporting Information:
Default Priority: 6
Parameter Group Number: 64917 (0xFD95)

Start Position	Length	Parameter Name	SPN
1.1	2 bits	Transmission Oil Filter Restriction Switch	3359
1.3	2 bits	Transmission Oil Level Switch	3533
2-3	2 bytes	Transmission Torque Converter Oil Outlet Temperature	3823
4	1 byte	Transmission Oil Life Remaining	4177

PGN 64920**Aftertreatment 1 Historical Information****- AT1HI**

Contains information about the history of the aftertreatment 1 system

Transmission Repetition Rate: On request
 Data Length: 32
 Extended Data Page: 0
 Data Page: 0
 PDU Format: 253
 PDU Specific: 152 PGN Supporting Information:
 Default Priority: 6
 Parameter Group Number: 64920 (0xFD98)

Start Position	Length	Parameter Name	SPN
01-04	4 bytes	Aftertreatment 1 Total Fuel Used	3522
05-08	4 bytes	Aftertreatment 1 Total Regeneration Time	3523
09-12	4 bytes	Aftertreatment 1 Total Disabled Time	3524
13-16	4 bytes	Aftertreatment 1 Total Number of Active Regenerations	3525
17-20	4 bytes	Aftertreatment 1 Total Passive Regeneration Time	3725
21-24	4 bytes	Aftertreatment 1 Total Number of Passive Regenerations	3726
25-28	4 bytes	Aftertreatment 1 Total Number of Active Regeneration Inhibit Requests	3727
29-32	4 bytes	Aftertreatment 1 Total Number of Active Regeneration Manual Requests	3728

PGN 64921**Aftertreatment 2 Historical information****- AT2HI**

Contains information about the history of the aftertreatment 2 system

Transmission Repetition Rate: On request
 Data Length: 32
 Extended Data Page: 0
 Data Page: 0
 PDU Format: 253
 PDU Specific: 153 PGN Supporting Information:
 Default Priority: 6
 Parameter Group Number: 64921 (0xFD99)

Start Position	Length	Parameter Name	SPN
01-04	4 bytes	Aftertreatment 2 Total Fuel Used	3526
05-08	4 bytes	Aftertreatment 2 Total Regeneration Time	3527
09-12	4 bytes	Aftertreatment 2 Total Disabled Time	3528
13-16	4 bytes	Aftertreatment 2 Total Number of Active Regenerations	3529
17-20	4 bytes	Aftertreatment 2 Total Passive Regeneration Time	3729
21-24	4 bytes	Aftertreatment 2 Total Number of Passive Regenerations	3730
25-28	4 bytes	Aftertreatment 2 Total Number of Active Regeneration Inhibit Requests	3731
29-32	4 bytes	Aftertreatment 2 Total Number of Active Regeneration Manual Requests	3732

PGN 64923**Catalyst Reagent Information****- CRI1**

Sensor Information which measures temperature, concentration, and conductivity of the catalyst reagent

Transmission Repetition Rate: 1 sec
 Data Length: 8
 Extended Data Page: 0
 Data Page: 0
 PDU Format: 253
 PDU Specific: 155 PGN Supporting Information:
 Default Priority: 6
 Parameter Group Number: 64923 (0xFD9B)

Start Position	Length	Parameter Name	SPN
1	1 byte	Catalyst Reagent Temperature 2	3515
2	1 byte	Catalyst Reagent Concentration	3516
3	1 byte	Catalyst Reagent Conductivity	3518
4.1	5 bits	Catalyst Reagent Temperature 2 Preliminary FMI	3519
5.1	5 bits	Catalyst Reagent Properties Preliminary FMI	3520
6.1	4 bits	Catalyst Reagent Type	3521

PGN 64924**Sensor Electrical Power #2****- SEP2**

Voltage supplies for sensors #2

Transmission Repetition Rate: 1 sec
 Data Length: 8
 Extended Data Page: 0
 Data Page: 0
 PDU Format: 253
 PDU Specific: 156 PGN Supporting Information: See Appendix D - PGN 65104
 Default Priority: 6
 Parameter Group Number: 64924 (0xFD9C)

Start Position	Length	Parameter Name	SPN
1-2	2 bytes	Sensor supply voltage 5	3513
3-4	2 bytes	Sensor supply voltage 6	3514

PGN 64925**Sensor Electrical Power #1****- SEP1**

Voltage supplies for sensors #1

Transmission Repetition Rate: 1 sec
 Data Length: 8
 Extended Data Page: 0
 Data Page: 0
 PDU Format: 253
 PDU Specific: 157 PGN Supporting Information: See Appendix D - PGN 65104
 Default Priority: 6
 Parameter Group Number: 64925 (0xFD9D)

Start Position	Length	Parameter Name	SPN
1-2	2 bytes	Sensor supply voltage 1	3509
3-4	2 bytes	Sensor supply voltage 2	3510
5-6	2 bytes	Sensor supply voltage 3	3511
7-8	2 bytes	Sensor supply voltage 4	3512

PGN 64926**Aftertreatment 2 Air Control 1****- AT2AC1**

Contains information about the aftertreatment 2 air system

Transmission Repetition Rate: 500 ms
 Data Length: 8
 Extended Data Page: 0
 Data Page: 0
 PDU Format: 253
 PDU Specific: 158 PGN Supporting Information:
 Default Priority: 6
 Parameter Group Number: 64926 (0xFD9E)

Start Position	Length	Parameter Name	SPN
1-2	2 bytes	Aftertreatment 2 Supply Air Pressure	3499
3-4	2 bytes	Aftertreatment 2 Purge Air Pressure	3500
5-6	2 bytes	Aftertreatment 2 Air Pressure Control	3501
7.1	1 byte	Aftertreatment 2 Air Pressure Actuator Position	3502
8.1	2 bits	Aftertreatment 2 Air System Relay	3506
8.3	2 bits	Aftertreatment 2 Atomization Air Actuator	3505
8.5	2 bits	Aftertreatment 2 Purge Air Actuator	3504
8.7	2 bits	Aftertreatment 2 Air Enable Actuator	3503

PGN 64927**Aftertreatment 1 Air Control 1****- AT1AC1**

Contains information about the aftertreatment 1 air system

Transmission Repetition Rate: 500 ms
 Data Length: 8
 Extended Data Page: 0
 Data Page: 0
 PDU Format: 253
 PDU Specific: 159 PGN Supporting Information:
 Default Priority: 6
 Parameter Group Number: 64927 (0xFD9F)

Start Position	Length	Parameter Name	SPN
1-2	2 bytes	Aftertreatment 1 Supply Air Pressure	3485
3-4	2 bytes	Aftertreatment 1 Purge Air Pressure	3486
5-6	2 bytes	Aftertreatment 1 Air Pressure Control	3487
7.1	1 byte	Aftertreatment 1 Air Pressure Actuator Position	3488
8.1	2 bits	Aftertreatment 1 Air System Relay	3492
8.3	2 bits	Aftertreatment 1 Atomization Air Actuator	3491
8.5	2 bits	Aftertreatment 1 Purge Air Actuator	3490
8.7	2 bits	Aftertreatment 1 Air Enable Actuator	3489

PGN 64928**Aftertreatment 2 Fuel Control 1****- AT2FC1**

Contains information about the aftertreatment 2 fuel system

Transmission Repetition Rate: 500 ms
 Data Length: 8
 Extended Data Page: 0
 Data Page: 0
 PDU Format: 253
 PDU Specific: 160 PGN Supporting Information:
 Default Priority: 6
 Parameter Group Number: 64928 (0xFDA0)

Start Position	Length	Parameter Name	SPN
1-2	2 bytes	Aftertreatment 2 Fuel Pressure 1	3494
3-4	2 bytes	Aftertreatment 2 Fuel Rate	3495
5-6	2 bytes	Aftertreatment 2 Fuel Pressure Control	3493
7.1	2 bits	Aftertreatment 2 Fuel Drain Actuator	4098
7.3	2 bits	Aftertreatment 2 Ignition	3498
7.5	2 bits	Aftertreatment 2 Regeneration Status	3497
7.7	2 bits	Aftertreatment 2 Fuel Enable Actuator	3496

PGN 64929**Aftertreatment 1 Fuel Control 1****- AT1FC1**

Contains information about the aftertreatment 1 fuel system

Transmission Repetition Rate: 500 ms
 Data Length: 8
 Extended Data Page: 0
 Data Page: 0
 PDU Format: 253
 PDU Specific: 161 PGN Supporting Information:
 Default Priority: 6
 Parameter Group Number: 64929 (0xFDA1)

Start Position	Length	Parameter Name	SPN
1-2	2 bytes	Aftertreatment 1 Fuel Pressure 1	3480
3-4	2 bytes	Aftertreatment 1 Fuel Rate	3481
5-6	2 bytes	Aftertreatment 1 Fuel Pressure Control	3479
7.1	2 bits	Aftertreatment 1 Fuel Drain Actuator	4097
7.3	2 bits	Aftertreatment 1 Ignition	3484
7.5	2 bits	Aftertreatment 1 Regeneration Status	3483
7.7	2 bits	Aftertreatment 1 Fuel Enable Actuator	3482

PGN 64930**Fuel Information 3 (Gaseous)****- GF13**

Gaseous fuel information 3

Transmission Repetition Rate: 500 ms
 Data Length: 8
 Extended Data Page: 0
 Data Page: 0
 PDU Format: 253
 PDU Specific: 162 PGN Supporting Information:
 Default Priority: 4
 Parameter Group Number: 64930 (0xFDA2)

Start Position	Length	Parameter Name	SPN
1-2	2 bytes	Engine Fuel Valve 2 Inlet Absolute Pressure	3466
3-4	2 bytes	Engine Gas 2 Mass Flow Rate	3467
5-6	1 byte	Engine Fuel Temperature 2	3468
7-8	2 bytes	Engine Fuel Valve 2 Outlet Absolute Pressure	3469

PGN 64931**Electronic Engine Controller 6****- EEC6**

Engine related parameters

Transmission Repetition Rate: 100 ms
 Data Length: 8
 Extended Data Page: 0
 Data Page: 0
 PDU Format: 253
 PDU Specific: 163 PGN Supporting Information:
 Default Priority: 4
 Parameter Group Number: 64931 (0xFDA3)

Start Position	Length	Parameter Name	SPN
1-2	2 bytes	Engine Turbocharger Compressor Control	3470
3	1 byte	Engine Variable Geometry Turbocharger Actuator #1	641
4	1 byte	Engine Turbocharger Compressor Bypass Actuator Position	3675

PGN 64932**PTO Drive Engagement****- PTODE**

Information relating to the request for engagement, consent for engagement, and status of engagement of various specific physical PTO drives. This message may be broadcast by one or all controllers involved in the enabling of a given PTO drive.

Transmission Repetition Rate: 100 ms
 Data Length: 8
 Extended Data Page: 0
 Data Page: 0
 PDU Format: 253
 PDU Specific: 164 PGN Supporting Information: See Appendix D - PGN 64932
 Default Priority: 6
 Parameter Group Number: 64932 (0xFDA4)

Start Position	Length	Parameter Name	SPN
1.1	2 bits	Enable Switch – Transfer case output shaft PTO	3455
1.3	2 bits	Enable Switch – Transmission output shaft PTO	3454
1.5	2 bits	Enable Switch – Transmission input shaft PTO 2	3453
1.7	2 bits	Enable Switch – Transmission input shaft PTO 1	3452
2.1	2 bits	Enable Switch - PTO Engine Flywheel	3939
2.3	2 bits	Enable Switch - PTO Engine Accessory Drive 1	3942
2.5	2 bits	Enable Switch - PTO Engine Accessory Drive 2	3945
3.1	2 bits	Engagement Consent – Transfer case output shaft PTO	3459
3.3	2 bits	Engagement Consent – Transmission output shaft PTO	3458
3.5	2 bits	Engagement Consent – Transmission input shaft PTO 2	3457
3.7	2 bits	Engagement Consent – Transmission input shaft PTO 1	3456
4.1	2 bits	Engagement Consent - PTO Engine Flywheel	3940
4.3	2 bits	Engagement Consent - PTO Engine Accessory Drive 1	3943
4.5	2 bits	Engagement Consent - PTO Engine Accessory Drive 2	3946
5.1	2 bits	Engagement Status – Transfer case output shaft PTO	3463
5.3	2 bits	Engagement Status – Transmission output shaft PTO	3462
5.5	2 bits	Engagement Status – Transmission input shaft PTO 2	3461
5.7	2 bits	Engagement Status – Transmission input shaft PTO 1	3460
6.1	2 bits	Engagement Status - PTO Engine Flywheel	3941
6.3	2 bits	Engagement Status - PTO Engine Accessory Drive 1	3944
6.5	2 bits	Engagement Status - PTO Engine Accessory Drive 2	3947
7.1	2 bits	At least one PTO engaged	3948

PGN 64933**Door Control 2****- DC2**

Used for door information.

Transmission Repetition Rate: 100 ms
 Data Length: 8
 Extended Data Page: 0
 Data Page: 0
 PDU Format: 253
 PDU Specific: 165 PGN Supporting Information:
 Default Priority: 6
 Parameter Group Number: 64933 (0xFDA5)

Start Position	Length	Parameter Name	SPN
1.1	2 bits	Lock Status of Door 1	3412
1.3	2 bits	Open Status of Door 1	3413
1.5	2 bits	Enable Status of Door 1	3414
1.7	2 bits	Lock Status of Door 2	3415
2.1	2 bits	Open Status of Door 2	3416
2.3	2 bits	Enable Status of Door 2	3417
2.5	2 bits	Lock Status of Door 3	3418
2.7	2 bits	Open Status of Door 3	3419
3.1	2 bits	Enable Status of Door 3	3420
3.3	2 bits	Lock Status of Door 4	3421
3.5	2 bits	Open Status of Door 4	3422
3.7	2 bits	Enable Status of Door 4	3423
4.1	2 bits	Lock Status of Door 5	3424
4.3	2 bits	Open Status of Door 5	3425
4.5	2 bits	Enable Status of Door 5	3426
4.7	2 bits	Lock Status of Door 6	3427
5.1	2 bits	Open Status of Door 6	3428
5.3	2 bits	Enable Status of Door 6	3429
5.5	2 bits	Lock Status of Door 7	3430
5.7	2 bits	Open Status of Door 7	3431
6.1	2 bits	Enable Status of Door 7	3432
6.3	2 bits	Lock Status of Door 8	3433
6.5	2 bits	Open Status of Door 8	3434
6.7	2 bits	Enable Status of Door 8	3435
7.1	2 bits	Lock Status of Door 9	3436
7.3	2 bits	Open Status of Door 9	3437
7.5	2 bits	Enable Status of Door 9	3438
7.7	2 bits	Lock Status of Door 10	3439
8.1	2 bits	Open Status of Door 10	3440
8.3	2 bits	Enable Status of Door 10	3441

PGN 64936 Wireless Communications Message 2 - WCM2

Message for reporting status information regarding the second instance of a wireless communications network on a device or system.

See PGN 64937 for the first wireless network.

Transmission Repetition Rate: On request
 Data Length: 8
 Extended Data Page: 0
 Data Page: 0
 PDU Format: 253
 PDU Specific: 168 PGN Supporting Information:
 Default Priority: 6
 Parameter Group Number: 64936 (0xFDA8)

Start Position	Length	Parameter Name	SPN
1	8 bits	Network Transceiver Status 2	3442
2	8 bits	Network Service Status 2	3443
3	8 bits	Network Antenna Status 2	3444
4	1 byte	Network Signal Strength 2	3445
5	8 bits	Wireless Communication Network Type 2	3446

PGN 64937 Wireless Communications Message 1 - WCM1

Message for reporting status information regarding the first instance of a wireless communications network on a device or system.

Transmission Repetition Rate: On request
 Data Length: 8
 Extended Data Page: 0
 Data Page: 0
 PDU Format: 253
 PDU Specific: 169 PGN Supporting Information:
 Default Priority: 6
 Parameter Group Number: 64937 (0xFDA9)

Start Position	Length	Parameter Name	SPN
1	8 bits	Network Transceiver Status 1	3368
2	8 bits	Network Service Status 1	3369
3	8 bits	Network Antenna Status 1	3370
4	1 byte	Network Signal Strength 1	3371
5	8 bits	Wireless Communication Network Type 1	3372

PGN 64938**Engine Fluid Level/Pressure 4****- EFL/P4**

4th PGN which identifies parameters that are either measuring various pressures within the engine or identifying engine fluid levels

Transmission Repetition Rate: 500 ms
 Data Length: 8
 Extended Data Page: 0
 Data Page: 0
 PDU Format: 253
 PDU Specific: 170 PGN Supporting Information: See Appendix D - PGN 64938
 Default Priority: 6
 Parameter Group Number: 64938 (0xFDAA)

Start Position	Length	Parameter Name	SPN
1	1 byte	Engine Charge Air Cooler 1 Inlet Pressure	3340
2	1 byte	Engine Charge Air Cooler 2 Inlet Pressure	3341
3	1 byte	Engine Coolant Pump Differential Pressure	3342
4-5	2 bytes	Engine Centrifugal Oil Filter speed	3343
6	1 byte	Engine Intercooler Coolant Level	3668
7	1 byte	Engine Aftercooler Coolant Level	3676
8	1 byte	Engine Charge Air Cooler Outlet Pressure	2631

PGN 64942**Fifth Wheel Smart Systems 2****- FWSS2**

Fifth wheel smart system information #2. Message to convey operator parameters associated with the tractor to trailer coupling control and error state.

Transmission Repetition Rate: On request
 Data Length: 8
 Extended Data Page: 0
 Data Page: 0
 PDU Format: 253
 PDU Specific: 174 PGN Supporting Information:
 Default Priority: 6
 Parameter Group Number: 64942 (0xFDAE)

Start Position	Length	Parameter Name	SPN
1.1	4 bits	Fifth Wheel Error Status	3307
1.5	2 bits	Fifth Wheel Lock Ready to Couple Indicator	3312
1.7	2 bits	Fifth Wheel Lock Couple Status Indicator	3313
2	1 byte	Fifth Wheel Slider Position	3311
3.1	2 bits	Fifth Wheel Slider Lock Indicator	3316

PGN 64943**Aftertreatment 2 Intermediate Gas****- AT2IMG**

The purpose of this PGN is to group the aftertreatment intermediate gas temperature and pressure messages for bank 2.

Transmission Repetition Rate: 500 ms
 Data Length: 8
 Extended Data Page: 0
 Data Page: 0
 PDU Format: 253
 PDU Specific: 175 PGN Supporting Information:
 Default Priority: 6
 Parameter Group Number: 64943 (0xFDAF)

Start Position	Length	Parameter Name	SPN
1	2 bytes	Aftertreatment 2 Exhaust Gas Temperature 2	3283
3	2 bytes	Aftertreatment 2 Diesel Particulate Filter Intermediate Gas Temperature	3284
5	2 bytes	Aftertreatment 2 Diesel Particulate Filter Differential Pressure	3285
7.1	5 bits	Aftertreatment 2 Exhaust Gas Temperature 2 Preliminary FMI	3286
7.6	5 bits	Aftertreatment 2 Diesel Particulate Filter Delta Pressure Preliminary FMI	3287
8.3	5 bits	Aftertreatment 2 Diesel Particulate Filter Intermediate Gas Temperature Preliminary FMI	3288

PGN 64944**Aftertreatment 2 Outlet Gas 2****- AT2OG2**

The purpose of this PGN is to group the aftertreatment outlet gas temperature messages for bank 2.

Transmission Repetition Rate: 500 ms
 Data Length: 8
 Extended Data Page: 0
 Data Page: 0
 PDU Format: 253
 PDU Specific: 176 PGN Supporting Information:
 Default Priority: 6
 Parameter Group Number: 64944 (0xFDB0)

Start Position	Length	Parameter Name	SPN
1	2 bytes	Aftertreatment 2 Exhaust Gas Temperature 3	3279
3	2 bytes	Aftertreatment 2 Diesel Particulate Filter Outlet Gas Temperature	3280
5.1	5 bits	Aftertreatment 2 Exhaust Gas Temperature 3 Preliminary FMI	3281
6.1	5 bits	Aftertreatment 2 Diesel Particulate Filter Exhaust Gas Temperature Preliminary FMI	3282

PGN 64945**Aftertreatment 2 Intake Gas 2****- AT2IG2**

The purpose of this PGN is to group the aftertreatment intake gas temperature messages for bank 2.

Transmission Repetition Rate: 500 ms
 Data Length: 8
 Extended Data Page: 0
 Data Page: 0
 PDU Format: 253
 PDU Specific: 177 PGN Supporting Information:
 Default Priority: 6
 Parameter Group Number: 64945 (0xFDB1)

Start Position	Length	Parameter Name	SPN
1	2 bytes	Aftertreatment 2 Exhaust Gas Temperature 1	3275
3	2 bytes	Aftertreatment 2 Diesel Particulate Filter Intake Gas Temperature	3276
5.1	5 bits	Aftertreatment 2 Exhaust Gas Temperature 1 Preliminary FMI	3277
6.1	5 bits	Aftertreatment 2 Diesel Particulate Filter Intake Gas Temperature Preliminary FMI	3278

PGN 64946**Aftertreatment 1 Intermediate Gas****- AT1IMG**

The purpose of this PGN is to group the aftertreatment intermediate gas temperature and pressure messages.

Transmission Repetition Rate: 500 ms
 Data Length: 8
 Extended Data Page: 0
 Data Page: 0
 PDU Format: 253
 PDU Specific: 178 PGN Supporting Information:
 Default Priority: 6
 Parameter Group Number: 64946 (0xFDB2)

Start Position	Length	Parameter Name	SPN
1	2 bytes	Aftertreatment 1 Exhaust Gas Temperature 2	3249
3	2 bytes	Aftertreatment 1 Diesel Particulate Filter Intermediate Gas Temperature	3250
5	2 bytes	Aftertreatment 1 Diesel Particulate Filter Differential Pressure	3251
7.1	5 bits	Aftertreatment 1 Exhaust Gas Temperature 2 Preliminary FMI	3252
7.6	5 bits	Aftertreatment 1 Diesel Particulate Filter Delta Pressure Preliminary FMI	3253
8.3	5 bits	Aftertreatment 1 Diesel Particulate Filter Intermediate Gas Temperature Preliminary FMI	3254

PGN 64947**Aftertreatment 1 Outlet Gas 2****- AT10G2**

The purpose of this PGN is to group the aftertreatment outlet gas temperature messages.

Transmission Repetition Rate: 500 ms
 Data Length: 8
 Extended Data Page: 0
 Data Page: 0
 PDU Format: 253
 PDU Specific: 179 PGN Supporting Information:
 Default Priority: 6
 Parameter Group Number: 64947 (0xFDB3)

Start Position	Length	Parameter Name	SPN
1	2 bytes	Aftertreatment 1 Exhaust Gas Temperature 3	3245
3	2 bytes	Aftertreatment 1 Diesel Particulate Filter Outlet Gas Temperature	3246
5.1	5 bits	Aftertreatment 1 Exhaust Gas Temperature 3 Preliminary FMI	3247
6.1	5 bits	Aftertreatment 1 Diesel Particulate Filter Outlet Exhaust Gas Temperature Preliminary FMI	3248

PGN 64948**Aftertreatment 1 Intake Gas 2****- AT11G2**

The purpose of this PGN is to group the aftertreatment intake gas temperature messages for bank 1.

Transmission Repetition Rate: 500 ms
 Data Length: 8
 Extended Data Page: 0
 Data Page: 0
 PDU Format: 253
 PDU Specific: 180 PGN Supporting Information:
 Default Priority: 6
 Parameter Group Number: 64948 (0xFDB4)

Start Position	Length	Parameter Name	SPN
1	2 bytes	Aftertreatment 1 Exhaust Gas Temperature 1	3241
3	2 bytes	Aftertreatment 1 Diesel Particulate Filter Intake Gas Temperature	3242
5.1	5 bits	Aftertreatment 1 Exhaust Gas Temperature 1 Preliminary FMI	3243
6.1	5 bits	Aftertreatment 1 Diesel Particulate Filter Intake Gas Temperature Preliminary FMI	3244

PGN 64953**Tire Pressure Reference Information****- TPRI**

Information on actual tire pressure reference value for monitoring.

NOTE—Message has to be repeated as necessary to transmit all available information. This method of location identification requires individual SPNs to be assigned to report failures specific to each individual component (I.e. each tire, each axle, etc.).

Transmission Repetition Rate: On request
 Data Length: 8
 Extended Data Page: 0
 Data Page: 0
 PDU Format: 253
 PDU Specific: 185 PGN Supporting Information:
 Default Priority: 6
 Parameter Group Number: 64953 (0xFDB9)

Start Position	Length	Parameter Name	SPN
1	8 bits	Tire Location	3190
2	1 byte	Reference Tire Pressure	3191

PGN 64954**Farebox Status****- TR6**

Used to report alarms of the fare collection unit.

Transmission Repetition Rate: On request
 Data Length: 8
 Extended Data Page: 0
 Data Page: 0
 PDU Format: 253
 PDU Specific: 186 PGN Supporting Information:
 Default Priority: 6
 Parameter Group Number: 64954 (0xFDBA)

Start Position	Length	Parameter Name	SPN
1.1	2 bits	Farebox Emergency Status	3179
2.1	7 bits	Farebox Alarm Identifier	3181

PGN 64955**Farebox Point of Sale****- TR5**

Used to report stop level point of sale detail.

Transmission Repetition Rate: On request
 Data Length: 8
 Extended Data Page: 0
 Data Page: 0
 PDU Format: 253
 PDU Specific: 187 PGN Supporting Information:
 Default Priority: 6
 Parameter Group Number: 64955 (0xFDBB)

Start Position	Length	Parameter Name	SPN
1.1	4 bits	Transaction Type	3170
1.5	4 bits	Passenger Type	3171
2.1	4 bits	Type of Fare	3176
2.5	4 bits	Payment Details	3177
3.1	4 bits	Fare Validity	3165
3.5	4 bits	Pass Category	3166
4.1	5 bits	Initial Fare Agency	3167
5.1	3 bits	Type of Service	3172
5.4	5 bits	Transfer Type	3173
6, 7.1	12 bits	Route Number	3169
8	1 byte	Transfer Sold	3168

PGN 64956**Farebox Service Detail****- TR4**

Used to identify service, assignments, and fare preset detail of the fare collection unit.

Transmission Repetition Rate: On request
 Data Length: 15
 Extended Data Page: 0
 Data Page: 0
 PDU Format: 253
 PDU Specific: 188 PGN Supporting Information:
 Default Priority: 6
 Parameter Group Number: 64956 (0xFDBC)

Start Position	Length	Parameter Name	SPN
01.1	2 bits	Farebox Service Status	3178
01.3	3 bits	Trip Status	3180
02.1	4 bits	Trip Direction	3174
03	8 bits	Fare Presets	3175
04-05	2 bytes	Trip Number	3159
06-07	2 bytes	Pattern Number	3161
08-09	2 bytes	Assigned Route	3160
10-11	2 bytes	Assigned Run	3162
12-13	2 bytes	Assigned Block	3163
14-15	2 bytes	Driver's farebox security code	3164

PGN 64957**Signal Preemption****- TR3**

Status and configuration of the device used for intersection preemption.

Transmission Repetition Rate: On request
 Data Length: 8
 Extended Data Page: 0
 Data Page: 0
 PDU Format: 253
 PDU Specific: 189 PGN Supporting Information:
 Default Priority: 6
 Parameter Group Number: 64957 (0xFDBD)

Start Position	Length	Parameter Name	SPN
1.3	2 bits	Range Code Enable	3081
1.5	2 bits	Transit Route ID Usage	3080
1.7	2 bits	Intersection Preemption Request/Response	3079
2.1	4 bits	Priority of Response Sent by Emitter	3084
2.5	2 bits	Transit Door Enable	3083
2.7	2 bits	Strobe Activation Control Status	3082
3,4	2 bytes	Vehicle ID	3085

PGN 64958**Transit Route****- TR1**

The current route assigned to this transit vehicle. The transit route information may be entered into different devices by different authorities (fare collection, radio log, unit control panel, etc.).

Transmission Repetition Rate: On request
 Data Length: variable
 Extended Data Page: 0
 Data Page: 0
 PDU Format: 253
 PDU Specific: 190 PGN Supporting Information:
 Default Priority: 6
 Parameter Group Number: 64958 (0xFDBE)

Start Position	Length	Parameter Name	SPN
1	1 byte	Agency	3078
2	1 byte	Number of bytes in the Transit Assigned Route Identity	3071
3	1 byte	Number of bytes in the Transit Assigned Run Identity	3072
4	1 byte	Number of bytes in the Transit Assigned Block Identity	3073
5 to A	Variable - up to 100 characters	Transit Assigned Route Identity	3074
A+1 to B	Variable - up to 100 characters	Transit Assigned Run Identity	3075
B+1 to C	Variable - up to 100 characters	Transit Assigned Block Identity	3076

PGN 64959 **Transit Milepost** **- TR2**

Identification of a transit route milepost

Transmission Repetition Rate: On request
 Data Length: variable
 Extended Data Page: 0
 Data Page: 0
 PDU Format: 253
 PDU Specific: 191 PGN Supporting Information:
 Default Priority: 6
 Parameter Group Number: 64959 (0xFDBF)

Start Position	Length	Parameter Name	SPN
1	1 byte	Number of bytes in the Milepost Identification	3070
2 to n	Variable - up to 100 characters	Milepost Identification	509

PGN 64960 **Passenger Counter** **- TR7**

Used to notify the transit link devices of real-time boarding and exiting passengers or to indicate the total number of passengers on vehicle referenced to the last transit stop.

Also transmits information on the use status of the vehicle.

Transmission Repetition Rate: On request
 Data Length: 8
 Extended Data Page: 0
 Data Page: 0
 PDU Format: 253
 PDU Specific: 192 PGN Supporting Information:
 Default Priority: 6
 Parameter Group Number: 64960 (0xFDC0)

Start Position	Length	Parameter Name	SPN
1	8 bits	Type of Passenger Count	3043
2	1 byte	Patron Count	3047
3.1	2 bits	Silent Alarm Status	3044
3.3	2 bits	Vehicle Use Status	3045
3.5	2 bits	Transit Run Status	3046

PGN 64961**Engine Fluid Level/Pressure 3****- EFL/P3**

3rd PGN which identifies parameters that are either measuring various pressures within the engine or identifying engine fluid levels

Transmission Repetition Rate: 500 ms

Data Length: 8

Extended Data Page: 0

Data Page: 0

PDU Format: 253

PDU Specific: 193 PGN Supporting Information:

Default Priority: 6

Parameter Group Number: 64961 (0xFDC1)

Start Position	Length	Parameter Name	SPN
1-2	2 bytes	Engine Intake Valve Actuation System Oil Pressure	2948
3	1 byte	Engine Exhaust Gas Recirculation Inlet Pressure	3358

PGN 64964**Electronic Brake Controller 5****- EBC5**

Used for information on brake control.

Transmission Repetition Rate: 100 ms

Data Length: 8

Extended Data Page: 0

Data Page: 0

PDU Format: 253

PDU Specific: 196 PGN Supporting Information:

Default Priority: 6

Parameter Group Number: 64964 (0xFDC4)

Start Position	Length	Parameter Name	SPN
1.1	2 bits	Brake Temperature Warning	3839
1.3	3 bits	Halt brake mode	2913
1.6	3 bits	Hill holder mode	2912
2.1	2 bits	Foundation Brake Use	2919
2.3	2 bits	XBR System State	2917
2.5	4 bits	XBR Active Control Mode	2918
3	1 byte	XBR Acceleration Limit	2921

PGN 64965**ECU Identification Information****- ECUID**

Message for reporting identification and information about the physical ECU and its hardware, such as the ECU's part number, serial number, build date, etc. Information about the software within the ECU should be reported using the Software Identification PGN 65242 and/or DM19.

NOTE - The fields in this message are optional and separated by an ASCII "**". It is not necessary to include parametric data for all fields; however, the delimiter ("**") is always required. An ASCII "**" is required at the end of the last included field, even if there is only one ECU identification designator. Any additional ECU identification fields defined in the future will be appended at the end, each separated by an ASCII "**" as a delimiter.

Transmission Repetition Rate: On request
 Data Length: Variable
 Extended Data Page: 0
 Data Page: 0
 PDU Format: 253
 PDU Specific: 197 PGN Supporting Information:
 Default Priority: 6
 Parameter Group Number: 64965 (0xFDC5)

Start Position	Length	Parameter Name	SPN
a	Variable - up to 200 characters (** delimited)	ECU Part Number	2901
b	Variable - up to 200 characters (** delimited)	ECU Serial Number	2902
c	Variable - up to 200 characters (** delimited)	ECU Location	2903
d	Variable - up to 200 characters (** delimited)	ECU Type	2904

PGN 64966 Cold Start Aids

-

Cold start aid information and settings.

Transmission Repetition Rate: As required
 Data Length: 8
 Extended Data Page: 0
 Data Page: 0
 PDU Format: 253
 PDU Specific: 198 PGN Supporting Information:
 Default Priority: 6
 Parameter Group Number: 64966 (0xFDC6)

Start Position	Length	Parameter Name	SPN
1.1	2 bits	Engine Start Enable Device 1	626
1.3	2 bits	Engine Start Enable Device 2	1804
2.1	4 bits	Engine Start Enable Device 1 Configuration	2899
2.5	4 bits	Engine Start Enable Device 2 Configuration	2898

PGN 64967 Off-Highway Engine Control Selection States

- OHCSS

Reports the states of off-highway engine control modes, as they apply to different modes of engine operation which may be used to aid particular working environments. These states provide the controls feedback for PGN 64971 which provides the operator inputs to the controller.

Transmission Repetition Rate: 0.5 s
 Data Length: 8
 Extended Data Page: 0
 Data Page: 0
 PDU Format: 253
 PDU Specific: 199 PGN Supporting Information:
 Default Priority: 6
 Parameter Group Number: 64967 (0xFDC7)

Start Position	Length	Parameter Name	SPN
1.1	2 bits	Engine Auxiliary Governor State	2896
1.3	2 bits	Engine Multi-Unit Sync State	2890
1.5	2 bits	Engine Alternate Low Idle Select State	2891
2	8 bits	Engine Alternate Rating Select State	2888
3.1	4 bits	Engine Alternate Droop Accelerator 1 Select State	2889
3.5	4 bits	Engine Alternate Droop Accelerator 2 Select State	2893
4.1	4 bits	Engine Alternate Droop Remote Accelerator Select State	2894
4.5	4 bits	Engine Alternate Droop Auxiliary Input Select State	2895

PGN 64968 Operator Primary Intermediate Speed Control state - ISCS

The Operator Primary Intermediate Speed Control State is used to provide the controller feedback to indicate the controls state achieved.

Transmission Repetition Rate: 1 s
 Data Length: 8
 Extended Data Page: 0
 Data Page: 0
 PDU Format: 253
 PDU Specific: 200 PGN Supporting Information:
 Default Priority: 6
 Parameter Group Number: 64968 (0xFDC8)

Start Position	Length	Parameter Name	SPN
1.1	4 bits	Engine Operator Primary Intermediate Speed Select State	2892

PGN 64969 Electronic Control Module Information - CMI

Information relating to electronic control modules

Transmission Repetition Rate: As required
 Data Length: 8
 Extended Data Page: 0
 Data Page: 0
 PDU Format: 253
 PDU Specific: 201 PGN Supporting Information:
 Default Priority: 7
 Parameter Group Number: 64969 (0xFDC9)

Start Position	Length	Parameter Name	SPN
1-2	2 bytes	Total Count of Configuration Changes Made	2887

PGN 64970**Intermediate Speed Control****- ISC**

The Intermediate Speed Control is widely used in the Industrial application to control the engine to an intermediate speed setting which can bypass the accelerator position control. An example of this operation would be in an agricultural application where an external device is connected to an output shaft from the engine which must then be controlled to a constant speed. This is accomplished by activating a switch setting, thus eliminating the need for the operator to attempt to control this speed with the accelerator position.

Transmission Repetition Rate: 1 s
 Data Length: 8
 Extended Data Page: 0
 Data Page: 0
 PDU Format: 253
 PDU Specific: 202 PGN Supporting Information:
 Default Priority: 6
 Parameter Group Number: 64970 (0xFDCA)

Start Position	Length	Parameter Name	SPN
1.1	4 bits	Engine Operator Primary Intermediate Speed Select	2880

PGN 64971**Off-Highway Engine Control Selection****- OHECS**

Allows for the selection of off-highway engine control modes, as they apply to different modes of engine operation which may be used to aid particular working environments. By offering characteristics suitable for the work in hand, the operator may select the desired mode (e.g. economy fuel ratings, droop settings, alternate idle points, multiple engine synchronization, etc.) to maximize performance under given conditions. The operator selects these inputs via hardware switch operation, whereby an overall system control communicates the information to the engine controller.

Transmission Repetition Rate: 500 ms
 Data Length: 8
 Extended Data Page: 0
 Data Page: 0
 PDU Format: 253
 PDU Specific: 203 PGN Supporting Information:
 Default Priority: 6
 Parameter Group Number: 64971 (0xFDCB)

Start Position	Length	Parameter Name	SPN
1.1	2 bits	Engine Auxiliary Governor Switch	2884
1.3	2 bits	Engine Synchronization Switch	1377
1.5	2 bits	Engine Alternate Low Idle Switch	2883
2	1 byte	Engine Alternate Rating Select	2882
3.1	4 bits	Engine Alternate Droop Accelerator 1 Select	2881
3.5	4 bits	Engine Alternate Droop Accelerator 2 Select	2879
4.1	4 bits	Engine Alternate Droop Remote Accelerator Select	2886
4.5	4 bits	Engine Alternate Droop Auxiliary Input Select	2885

PGN 64972 Operators External Light Controls Message - OEL

The message containing the information about the position of the operator's external light control switch(s). Including switches for the Headlights, turn signals, hazard light, clearance lights, marker lights, etc.

Transmission Repetition Rate: On change of switch. Maximum period of 1 second between messages. No greater than 10 messages per second for all switches.

Data Length: 8
 Extended Data Page: 0
 Data Page: 0
 PDU Format: 253
 PDU Specific: 204 PGN Supporting Information:
 Default Priority: 3
 Parameter Group Number: 64972 (0xFDCC)

Start Position	Length	Parameter Name	SPN
1.1	4 bits	Work Light Switch	2873
1.5	4 bits	Main Light Switch	2872
2.1	4 bits	Turn Signal Switch	2876
2.5	2 bits	Hazard Light Switch	2875
2.7	2 bits	High-Low Beam Switch	2874
3	1 byte	Operators Desired Back-light	2878
4-5	2 bytes	Operators Desired - Delayed Lamp Off Time	2877

PGN 64973 Operator Wiper and Washer Controls Message - OWW

Message for items related to the operators controls for the window wipers and washers on the front and rear cab windows

Transmission Repetition Rate: 200 ms
 Data Length: 8
 Extended Data Page: 0
 Data Page: 0
 PDU Format: 253
 PDU Specific: 205 PGN Supporting Information:
 Default Priority: 6
 Parameter Group Number: 64973 (0xFDCC)

Start Position	Length	Parameter Name	SPN
1.1	4 bits	Front Non-operator Wiper Switch	2864
1.5	4 bits	Front Operator Wiper Switch	2863
2.5	4 bits	Rear Wiper Switch	2865
3	1 byte	Front Operator Wiper Delay Control	2869
4	1 byte	Front Non-operator Wiper Delay Control	2870
5	1 byte	Rear Wiper Delay Control	2871
6.3	3 bits	Front Non-operator Washer Switch	2867
6.6	3 bits	Front Operator Washer Switch	2866
7.6	3 bits	Rear Washer Function	2868

PGN 64976**Inlet/Exhaust Conditions 2****- IC2**

Inlet/Exhaust Conditions 2 is a second PGN conveying this type of engine information. Also see PGN 65270.

Transmission Repetition Rate: 0.5 s
 Data Length: 8
 Extended Data Page: 0
 Data Page: 0
 PDU Format: 253
 PDU Specific: 208 PGN Supporting Information:
 Default Priority: 6
 Parameter Group Number: 64976 (0xFDD0)

Start Position	Length	Parameter Name	SPN
1	1 byte	Engine Air Filter 2 Differential Pressure	2809
2	1 byte	Engine Air Filter 3 Differential Pressure	2810
3	1 byte	Engine Air Filter 4 Differential Pressure	2811
4	1 byte	Engine Intake Manifold #2 Pressure	3562
5	1 byte	Engine Intake Manifold #1 Absolute Pressure	3563

PGN 64977**FMS-standard Interface Identity/Capabilities****- FMS**

Information which specifies the capabilities of the Fleet Management System (FMS) - standard interface device. This PGN typically is sourced from the network interconnect FMS - standard interface device.

Transmission Repetition Rate: 10 s
 Data Length: 8
 Extended Data Page: 0
 Data Page: 0
 PDU Format: 253
 PDU Specific: 209 PGN Supporting Information:
 Default Priority: 7
 Parameter Group Number: 64977 (0xFDD1)

Start Position	Length	Parameter Name	SPN
1.1	2 bits	FMS-standard Diagnostics Supported	2804
1.3	2 bits	FMS-standard Requests Supported	2805
2-5	4 bytes	FMS-standard SW-version supported.	2806

PGN 64978**ECU Performance****- EP**

Message used to transfer ECU performance parameters.

Transmission Repetition Rate: On request
 Data Length: 8
 Extended Data Page: 0
 Data Page: 0
 PDU Format: 253
 PDU Specific: 210 PGN Supporting Information:
 Default Priority: 6
 Parameter Group Number: 64978 (0xFDD2)

Start Position	Length	Parameter Name	SPN
1-2	2 bytes	Keep-Alive Battery Consumption	2803
3	1 byte	Data Memory Usage	2802

PGN 64979**Turbocharger Information 6****- TCI6**

Transmission Repetition Rate: 1 s
 Data Length: 8
 Extended Data Page: 0
 Data Page: 0
 PDU Format: 253
 PDU Specific: 211 PGN Supporting Information:
 Default Priority: 6
 Parameter Group Number: 64979 (0xFDD3)

Start Position	Length	Parameter Name	SPN
1-2	2 bytes	Engine Turbocharger 1 Compressor Outlet Temperature	2629
3-4	2 bytes	Engine Turbocharger 2 Compressor Outlet Temperature	2799
5-6	2 bytes	Engine Turbocharger 3 Compressor Outlet Temperature	2800
7-8	2 bytes	Engine Turbocharger 4 Compressor Outlet Temperature	2801

PGN 64980**Cab Message 3****- CM3**

Provides information from Cab mounted operator inputs.

Transmission Repetition Rate: On-change or every 10 s
 Data Length: 8
 Extended Data Page: 0
 Data Page: 0
 PDU Format: 253
 PDU Specific: 212 PGN Supporting Information:
 Default Priority: 6
 Parameter Group Number: 64980 (0xFDD4)

Start Position	Length	Parameter Name	SPN
1.1	3 bits	Transfer Case Selector Switch	2796
2.1	2 bits	Fifth Wheel Release Control	3314
2.3	2 bits	Fifth Wheel Release Control Security Lockout	3315
3.1	2 bits	Transmission Oil Level Request	3809

PGN 64981**Electronic Engine Controller 5****- EEC5**

Engine related parameters

Transmission Repetition Rate: On request
 Data Length: 8
 Extended Data Page: 0
 Data Page: 0
 PDU Format: 253
 PDU Specific: 213 PGN Supporting Information:
 Default Priority: 6
 Parameter Group Number: 64981 (0xFDD5)

Start Position	Length	Parameter Name	SPN
1-2	2 bytes	Engine Turbocharger 1 Calculated Turbine Inlet Temperature	2789
3-4	2 bytes	Engine Turbocharger 1 Calculated Turbine Outlet Temperature	2790
5-6	2 bytes	Engine Exhaust Gas Recirculation (EGR) Valve Control	2791
7.1	2 bits	Engine Variable Geometry Turbocharger (VGT) Air Control Shutoff Valve	2792
8	1 byte	Engine Variable Geometry Turbocharger (VGT) 1 Actuator Position	2795

PGN 64982**Basic Joystick Message 1****- BJM1**

Used to transfer information about the measured status of the 1st 2 axes and up to 12 buttons of a joystick. Additional handle information is available in the Expanded Joystick Message.

10-bit position parameters are broadcast over 2 bytes. The eight most significant bits are transmitted in the second byte, with the most significant bit at bit 8. The two least significant bits are transmitted in the first byte in bit positions 7 and 8, with the most significant of the two bits at bit 8.

10-bit position SPN	Location in PGN	
Bit 10	Byte n	Bit 8
Bit 9		Bit 7
Bit 8		Bit 6
Bit 7		Bit 5
Bit 6		Bit 4
Bit 5		Bit 3
Bit 4		Bit 2
Bit 3		Bit 1
Bit 2	Byte (n-1)	Bit 8
Bit 1		Bit 7

Transmission Repetition Rate: 100 ms or on change, not to exceed 20 ms
 Data Length: 8
 Extended Data Page: 0
 Data Page: 0
 PDU Format: 253
 PDU Specific: 214 PGN Supporting Information:
 Default Priority: 3
 Parameter Group Number: 64982 (0xFDD6)

Start Position	Length	Parameter Name	SPN
1.1	2 bits	Joystick 1 X-Axis Neutral Position Status	2675
1.3	2 bits	Joystick 1 X-Axis Lever Left Negative Position Status	2670
1.5	2 bits	Joystick 1 X-Axis Lever Right Positive Position Status	2665
1.7-2	10 bits	Joystick 1 X-Axis Position	2660
3.1	2 bits	Joystick 1 Y-Axis Neutral Position Status	2676
3.3	2 bits	Joystick 1 Y-Axis Lever Back Negative Position Status	2671
3.5	2 bits	Joystick 1 Y-Axis Lever Forward Positive Position Status	2666
3.7-4	10 bits	Joystick 1 Y-Axis Position	2661
5.5	2 bits	Joystick 1 Y-Axis Detent Position Status	2681
5.7	2 bits	Joystick 1 X-Axis Detent Position Status	2680
6.1	2 bits	Joystick 1 Button 4 Pressed Status	2688
6.3	2 bits	Joystick 1 Button 3 Pressed Status	2687
6.5	2 bits	Joystick 1 Button 2 Pressed Status	2686
6.7	2 bits	Joystick 1 Button 1 Pressed Status	2685
7.1	2 bits	Joystick 1 Button 8 Pressed Status	2692
7.3	2 bits	Joystick 1 Button 7 Pressed Status	2691
7.5	2 bits	Joystick 1 Button 6 Pressed Status	2690
7.7	2 bits	Joystick 1 Button 5 Pressed Status	2689
8.1	2 bits	Joystick 1 Button 12 Pressed Status	2696
8.3	2 bits	Joystick 1 Button 11 Pressed Status	2695
8.5	2 bits	Joystick 1 Button 10 Pressed Status	2694
8.7	2 bits	Joystick 1 Button 9 Pressed Status	2693

PGN 64983**Extended Joystick Message 1****- EJM1**

Used to transfer information about the measured status of three additional axes of a joystick and switches of the joystick grip or handle. The joystick axial motion information is available in the Basic Joystick Message.

10-bit position parameters are broadcast over 2 bytes. The eight most significant bits are transmitted in the second byte, with the most significant bit at bit 8. The two least significant bits are transmitted in the first byte in bit positions 7 and 8, with the most significant of the two bits at bit 8.

10-bit position SPN	Location in PGN	
Bit 10	Byte n	Bit 8
Bit 9		Bit 7
Bit 8		Bit 6
Bit 7		Bit 5
Bit 6		Bit 4
Bit 5		Bit 3
Bit 4		Bit 2
Bit 3		Bit 1
Bit 2	Byte (n-1)	Bit 8
Bit 1		Bit 7

Note: The term Grip used here simply refers to another set of axes separate from the previously mentioned X and Y Axis. This additional set of axes could in some cases be grip mounted sensors as opposed to the sensors mounted at the base of the handle.

Transmission Repetition Rate:	100 ms or on change, not to exceed 20 ms	
Data Length:	8	
Extended Data Page:	0	
Data Page:	0	
PDU Format:	253	
PDU Specific:	215	PGN Supporting Information:
Default Priority:	3	
Parameter Group Number:	64983	(0xFDD7)

Start Position	Length	Parameter Name	SPN
1.1	2 bits	Joystick 1 Grip X-Axis Neutral Position Status	2677
1.3	2 bits	Joystick 1 Grip X-Axis Lever Left Negative Position Status	2672
1.5	2 bits	Joystick 1 Grip X-Axis Lever Right Positive Position Status	2667
1.7-2	10 bits	Joystick 1 Grip X-Axis Position	2662
3.1	2 bits	Joystick 1 Grip Y-Axis Neutral Position Status	2678
3.3	2 bits	Joystick 1 Grip Y-Axis Lever Back Negative Position Status	2673
3.5	2 bits	Joystick 1 Grip Y-Axis Lever Forward Positive Position Status	2668
3.7-4	10 bits	Joystick 1 Grip Y-Axis Position	2663
5.1	2 bits	Joystick 1 Theta-Axis Neutral Position Status	2679
5.3	2 bits	Joystick 1 Theta-Axis Counter Clockwise Negative Position Status	2674
5.5	2 bits	Joystick 1 Theta-Axis Clockwise Positive Position Status	2669
5.7-6	10 bits	Joystick 1 Theta-Axis Position	2664
7.3	2 bits	Joystick 1 Theta-Axis Detent Position Status	2684
7.5	2 bits	Joystick 1 Grip Y-Axis Detent Position Status	2683
7.7	2 bits	Joystick 1 Grip X-Axis Detent Position Status	2682

PGN 64984**Basic Joystick Message 2****- BJM2**

Used to transfer information about the measured status of the 1st 2 axes and up to 12 buttons of a joystick. Additional handle information is available in the Expanded Joystick Message.

10-bit position parameters are broadcast over 2 bytes. The eight most significant bits are transmitted in the second byte, with the most significant bit at bit 8. The two least significant bits are transmitted in the first byte in bit positions 7 and 8, with the most significant of the two bits at bit 8.

10-bit position SPN	Location in PGN	
Bit 10	Byte n	Bit 8
Bit 9		Bit 7
Bit 8		Bit 6
Bit 7		Bit 5
Bit 6		Bit 4
Bit 5		Bit 3
Bit 4		Bit 2
Bit 3		Bit 1
Bit 2	Byte (n-1)	Bit 8
Bit 1		Bit 7

Transmission Repetition Rate: 100 ms or on change, not to exceed 20 ms
 Data Length: 8
 Extended Data Page: 0
 Data Page: 0
 PDU Format: 253
 PDU Specific: 216 PGN Supporting Information:
 Default Priority: 3
 Parameter Group Number: 64984 (0xFDD8)

Start Position	Length	Parameter Name	SPN
1.1	2 bits	Joystick 2 X-Axis Neutral Position Status	2712
1.3	2 bits	Joystick 2 X-Axis Lever Left Negative Position Status	2707
1.5	2 bits	Joystick 2 X-Axis Lever Right Positive Position Status	2702
1.7-2	10 bits	Joystick 2 X-Axis Position	2697
3.1	2 bits	Joystick 2 Y-Axis Neutral Position Status	2713
3.3	2 bits	Joystick 2 Y-Axis Lever Back Negative Position Status	2708
3.5	2 bits	Joystick 2 Y-Axis Lever Forward Positive Position Status	2703
3.7-4	10 bits	Joystick 2 Y-Axis Position	2698
5.5	2 bits	Joystick 2 Y-Axis Detent Position Status	2718
5.7	2 bits	Joystick 2 X-Axis Detent Position Status	2717
6.1	2 bits	Joystick 2 Button 4 Pressed Status	2725
6.3	2 bits	Joystick 2 Button 3 Pressed Status	2724
6.5	2 bits	Joystick 2 Button 2 Pressed Status	2723
6.7	2 bits	Joystick 2 Button 1 Pressed Status	2722
7.1	2 bits	Joystick 2 Button 8 Pressed Status	2729
7.3	2 bits	Joystick 2 Button 7 Pressed Status	2728
7.5	2 bits	Joystick 2 Button 6 Pressed Status	2727
7.7	2 bits	Joystick 2 Button 5 Pressed Status	2726
8.1	2 bits	Joystick 2 Button 12 Pressed Status	2733
8.3	2 bits	Joystick 2 Button 11 Pressed Status	2732
8.5	2 bits	Joystick 2 Button 10 Pressed Status	2731
8.7	2 bits	Joystick 2 Button 9 Pressed Status	2730

PGN 64985**Extended Joystick Message 2****- EJM2**

Used to transfer information about the measured status of three additional axes of a joystick and switches of the joystick grip or handle. The joystick axial motion information is available in the Basic Joystick Message.

10-bit position parameters are broadcast over 2 bytes. The eight most significant bits are transmitted in the second byte, with the most significant bit at bit 8. The two least significant bits are transmitted in the first byte in bit positions 7 and 8, with the most significant of the two bits at bit 8.

10-bit position SPN	Location in PGN	
Bit 10	Byte n	Bit 8
Bit 9		Bit 7
Bit 8		Bit 6
Bit 7		Bit 5
Bit 6		Bit 4
Bit 5		Bit 3
Bit 4		Bit 2
Bit 3		Bit 1
Bit 2	Byte (n-1)	Bit 8
Bit 1		Bit 7

Note: The term Grip used here simply refers to another set of axes separate from the previously mentioned X and Y Axis. This additional set of axes could in some cases be grip mounted sensors as opposed to the sensors mounted at the base of the handle.

Transmission Repetition Rate:	100 ms or on change, not to exceed 20 ms	
Data Length:	8	
Extended Data Page:	0	
Data Page:	0	
PDU Format:	253	
PDU Specific:	217	PGN Supporting Information:
Default Priority:	3	
Parameter Group Number:	64985	(0xFDD9)

Start Position	Length	Parameter Name	SPN
1.1	2 bits	Joystick 2 Grip X-Axis Neutral Position Status	2714
1.3	2 bits	Joystick 2 Grip X-Axis Lever Left Negative Position Status	2709
1.5	2 bits	Joystick 2 Grip X-Axis Lever Right Positive Position Status	2704
1.7-2	10 bits	Joystick 2 Grip X-Axis Position	2699
3.1	2 bits	Joystick 2 Grip Y-Axis Neutral Position Status	2715
3.3	2 bits	Joystick 2 Grip Y-Axis Lever Back Negative Position Status	2710
3.5	2 bits	Joystick 2 Grip Y-Axis Lever Forward Positive Position Status	2705
3.7-4	10 bits	Joystick 2 Grip Y-Axis Position	2700
5.1	2 bits	Joystick 2 Theta-Axis Neutral Position Status	2716
5.3	2 bits	Joystick 2 Theta-Axis Counter Clockwise Negative Position Status	2711
5.5	2 bits	Joystick 2 Theta-Axis Clockwise Positive Position Status	2706
5.7-6	10 bits	Joystick 2 Theta-Axis Position	2701
7.3	2 bits	Joystick 2 Theta-Axis Detent Position Status	2721
7.5	2 bits	Joystick 2 Grip Y-Axis Detent Position Status	2720
7.7	2 bits	Joystick 2 Grip X-Axis Detent Position Status	2719

PGN 64986**Basic Joystick Message 3****- BJM3**

Used to transfer information about the measured status of the 1st 2 axes and up to 12 buttons of a joystick. Additional handle information is available in the Expanded Joystick Message.

10-bit position parameters are broadcast over 2 bytes. The eight most significant bits are transmitted in the second byte, with the most significant bit at bit 8. The two least significant bits are transmitted in the first byte in bit positions 7 and 8, with the most significant of the two bits at bit 8.

10-bit position SPN	Location in PGN	
Bit 10	Byte n	Bit 8
Bit 9		Bit 7
Bit 8		Bit 6
Bit 7		Bit 5
Bit 6		Bit 4
Bit 5		Bit 3
Bit 4		Bit 2
Bit 3		Bit 1
Bit 2	Byte (n-1)	Bit 8
Bit 1		Bit 7

Transmission Repetition Rate: 100 ms or on change, not to exceed 20 ms
 Data Length: 8
 Extended Data Page: 0
 Data Page: 0
 PDU Format: 253
 PDU Specific: 218 PGN Supporting Information:
 Default Priority: 3
 Parameter Group Number: 64986 (0xFDDA)

Start Position	Length	Parameter Name	SPN
1.1	2 bits	Joystick 3 X-Axis Neutral Position Status	2749
1.3	2 bits	Joystick 3 X-Axis Lever Left Negative Position Status	2744
1.5	2 bits	Joystick 3 X-Axis Lever Right Positive Position Status	2739
1.7-2	10 bits	Joystick 3 X-Axis Position	2734
3.1	2 bits	Joystick 3 Y-Axis Neutral Position Status	2750
3.3	2 bits	Joystick 3 Y-Axis Lever Back Negative Position Status	2745
3.5	2 bits	Joystick 3 Y-Axis Lever Forward Positive Position Status	2740
3.7-4	10 bits	Joystick 3 Y-Axis Position	2735
5.5	2 bits	Joystick 3 Y-Axis Detent Position Status	2755
5.7	2 bits	Joystick 3 X-Axis Detent Position Status	2754
6.1	2 bits	Joystick 3 Button 4 Pressed Status	2762
6.3	2 bits	Joystick 3 Button 3 Pressed Status	2761
6.5	2 bits	Joystick 3 Button 2 Pressed Status	2760
6.7	2 bits	Joystick 3 Button 1 Pressed Status	2759
7.1	2 bits	Joystick 3 Button 8 Pressed Status	2766
7.3	2 bits	Joystick 3 Button 7 Pressed Status	2765
7.5	2 bits	Joystick 3 Button 6 Pressed Status	2764
7.7	2 bits	Joystick 3 Button 5 Pressed Status	2763
8.1	2 bits	Joystick 3 Button 12 Pressed Status	2770
8.3	2 bits	Joystick 3 Button 11 Pressed Status	2769
8.5	2 bits	Joystick 3 Button 10 Pressed Status	2768
8.7	2 bits	Joystick 3 Button 9 Pressed Status	2767

PGN 64987**Extended Joystick Message 3****- EJM3**

Used to transfer information about the measured status of three additional axes of a joystick and switches of the joystick grip or handle. The joystick axial motion information is available in the Basic Joystick Message.

10-bit position parameters are broadcast over 2 bytes. The eight most significant bits are transmitted in the second byte, with the most significant bit at bit 8. The two least significant bits are transmitted in the first byte in bit positions 7 and 8, with the most significant of the two bits at bit 8.

10-bit position SPN	Location in PGN	
Bit 10	Byte n	Bit 8
Bit 9		Bit 7
Bit 8		Bit 6
Bit 7		Bit 5
Bit 6		Bit 4
Bit 5		Bit 3
Bit 4		Bit 2
Bit 3		Bit 1
Bit 2	Byte (n-1)	Bit 8
Bit 1		Bit 7

Note: The term Grip used here simply refers to another set of axes separate from the previously mentioned X and Y Axis. This additional set of axes could in some cases be grip mounted sensors as opposed to the sensors mounted at the base of the handle.

Transmission Repetition Rate:	100 ms or on change, not to exceed 20 ms	
Data Length:	8	
Extended Data Page:	0	
Data Page:	0	
PDU Format:	253	
PDU Specific:	219	PGN Supporting Information:
Default Priority:	3	
Parameter Group Number:	64987	(0xFDDDB)

Start Position	Length	Parameter Name	SPN
1.1	2 bits	Joystick 3 Grip X-Axis Neutral Position Status	2751
1.3	2 bits	Joystick 3 Grip X-Axis Lever Left Negative Position Status	2746
1.5	2 bits	Joystick 3 Grip X-Axis Lever Right Positive Position Status	2741
1.7-2	10 bits	Joystick 3 Grip X-Axis Position	2736
3.1	2 bits	Joystick 3 Grip Y-Axis Neutral Position Status	2752
3.3	2 bits	Joystick 3 Grip Y-Axis Lever Back Negative Position Status	2747
3.5	2 bits	Joystick 3 Grip Y-Axis Lever Forward Positive Position Status	2742
3.7-4	10 bits	Joystick 3 Grip Y-Axis Position	2737
5.1	2 bits	Joystick 3 Theta-Axis Neutral Position Status	2753
5.3	2 bits	Joystick 3 Theta-Axis Counter Clockwise Negative Position Status	2748
5.5	2 bits	Joystick 3 Theta-Axis Clockwise Positive Position Status	2743
5.7-6	10 bits	Joystick 3 Theta-Axis Position	2738
7.3	2 bits	Joystick 3 Theta-Axis Detent Position Status	2758
7.5	2 bits	Joystick 3 Grip Y-Axis Detent Position Status	2757
7.7	2 bits	Joystick 3 Grip X-Axis Detent Position Status	2756

PGN 64988**Marine Control Information****- MCI**

This messages contains marine vessel control information for the engine

Transmission Repetition Rate: 1 s
 Data Length: 8
 Extended Data Page: 0
 Data Page: 0
 PDU Format: 253
 PDU Specific: 220 PGN Supporting Information:
 Default Priority: 6
 Parameter Group Number: 64988 (0xFDDC)

Start Position	Length	Parameter Name	SPN
1.1	4 bits	Engine Throttle Synchronization Mode Status	2615
1.5	2 bits	Trolling Mode Status	2616
1.7	2 bits	Slow Vessel Mode Status	2617

PGN 64991**Front Wheel Drive Status****- FWD**

Front wheel drive ECU information

Transmission Repetition Rate: 0.5 s
 Data Length: 8
 Extended Data Page: 0
 Data Page: 0
 PDU Format: 253
 PDU Specific: 223 PGN Supporting Information:
 Default Priority: 7
 Parameter Group Number: 64991 (0xFDDF)

Start Position	Length	Parameter Name	SPN
1.1	2 bits	Front Wheel Drive Actuator Status	2612

PGN 64992**Ambient Conditions 2****- AMB2**

This message contains measurement and configuration information about the vehicle ambient conditions.

Transmission Repetition Rate: 1 s
 Data Length: 8
 Extended Data Page: 0
 Data Page: 0
 PDU Format: 253
 PDU Specific: 224 PGN Supporting Information:
 Default Priority: 6
 Parameter Group Number: 64992 (0xFDE0)

Start Position	Length	Parameter Name	SPN
1	1 byte	Solar Intensity Percent	2610
2	1 byte	Solar Sensor Maximum	2611

PGN 64993 Cab A/C Climate System Information - CACI

This message contains measurement and condition information from cab air conditioning components.

Transmission Repetition Rate: 1 s

Data Length: 8

Extended Data Page: 0

Data Page: 0

PDU Format: 253

PDU Specific: 225 PGN Supporting Information:

Default Priority: 6

Parameter Group Number: 64993 (0xFDE1)

Start Position	Length	Parameter Name	SPN
1	1 byte	Cab A/C Refrigerant Compressor Outlet Pressure	2609

PGN 64994 Supply Pressure Demand - SPR

Used for controlling the supply pressure. Often used to raise the pressure of a supply pressure circuit in situations where more pneumatic energy is needed.

This message is the setpoint for the PGN 65198 message.

Transmission Repetition Rate: 1 s, when active

Data Length: 8

Extended Data Page: 0

Data Page: 0

PDU Format: 253

PDU Specific: 226 PGN Supporting Information:

Default Priority: 6

Parameter Group Number: 64994 (0xFDE2)

Start Position	Length	Parameter Name	SPN
1	1 byte	Pneumatic Supply Pressure Request	2603
2	1 byte	Parking and/or Trailer Air Pressure Request	2604
3	1 byte	Service Brake Air Pressure Request, Circuit #1	2605
4	1 byte	Service Brake Air Pressure Request, Circuit #2	2606
5	1 byte	Auxiliary Equipment Supply Pressure Request	2607
6	1 byte	Air Suspension Supply Pressure Request	2608

PGN 64995**Equipment Operation and Control****- EOAC**

Parameters related to the operation and controls for equipment

Transmission Repetition Rate: 250 mS
 Data Length: 8
 Extended Data Page: 0
 Data Page: 0
 PDU Format: 253
 PDU Specific: 227 PGN Supporting Information:
 Default Priority: 6
 Parameter Group Number: 64995 (0xFDE3)

Start Position	Length	Parameter Name	SPN
1	1 byte	Travel Velocity Control Position	2601

PGN 64996**Equipment Performance Data****- EPD**

Parameters related to the performance characteristics of equipment

Transmission Repetition Rate: 500 mS
 Data Length: 8
 Extended Data Page: 0
 Data Page: 0
 PDU Format: 253
 PDU Specific: 228 PGN Supporting Information:
 Default Priority: 6
 Parameter Group Number: 64996 (0xFDE4)

Start Position	Length	Parameter Name	SPN
1	1 byte	Payload Percentage	2600

PGN 64997**Maximum Vehicle Speed Limit Status****- MVS**

Reports the possible maximum vehicle speed limits, one through seven, and the applied maximum vehicle speed limit.

Transmission Repetition Rate: 1 s
 Data Length: 8
 Extended Data Page: 0
 Data Page: 0
 PDU Format: 253
 PDU Specific: 229 PGN Supporting Information:
 Default Priority: 6
 Parameter Group Number: 64997 (0xFDE5)

Start Position	Length	Parameter Name	SPN
1	1 byte	Maximum Vehicle Speed Limit 1	2588
2	1 byte	Maximum Vehicle Speed Limit 2	2589
3	1 byte	Maximum Vehicle Speed Limit 3	2590
4	1 byte	Maximum Vehicle Speed Limit 4	2591
5	1 byte	Maximum Vehicle Speed Limit 5	2592
6	1 byte	Maximum Vehicle Speed Limit 6	2593
7	1 byte	Maximum Vehicle Speed Limit 7	2594
8	1 byte	Applied Vehicle Speed Limit	2595

PGN 64998**Hydraulic Braking System****- HBS**

Used for information on a hydraulic brake system

As an example: this PGN may be used for a two circuit hydraulic brake system with separate circuits for front and rear axle. The hydraulic energy is supplied via two independent electrically driven pumps. The energy is stored in gas filled hydraulic accumulators also separated for each circuit.

Transmission Repetition Rate: 100 ms
 Data Length: 8
 Extended Data Page: 0
 Data Page: 0
 PDU Format: 253
 PDU Specific: 230 PGN Supporting Information:
 Default Priority: 3
 Parameter Group Number: 64998 (0xFDE6)

Start Position	Length	Parameter Name	SPN
1	1 byte	Hydraulic Brake Pressure Circuit 1	2580
2	1 byte	Hydraulic Brake Pressure Circuit 2	2581
3.1	2 bits	Hydraulic Brake Pressure Warning State Circuit 1	2584
3.3	2 bits	Hydraulic Brake Pressure Warning State Circuit 2	2585
3.5	2 bits	Hydraulic Brake Pressure Supply State Circuit 1	2582
3.7	2 bits	Hydraulic Brake Pressure Supply State Circuit 2	2583
4.1	2 bits	Hydraulic Brake System Audible Warning Command	2930
4.3	2 bits	Hydraulic Brake Fluid Level Switch	2931

PGN 65031**Exhaust Temperature****- ET**

Transmission Repetition Rate: 0.5 s
 Data Length: 8
 Extended Data Page: 0
 Data Page: 0
 PDU Format: 254
 PDU Specific: 7 PGN Supporting Information:
 Default Priority: 6
 Parameter Group Number: 65031 (0xFE07)

Start Position	Length	Parameter Name	SPN
1-2	2 bytes	Engine Exhaust Gas Temperature - Right Manifold	2433
3-4	2 bytes	Engine Exhaust Gas Temperature - Left Manifold	2434

PGN 65088**Lighting Data****- LD**

This lighting message is a response to the request for lighting data in the lighting command message. Each lighting controller on the tractor and attached implements must transmit this message to the Tractor ECU when requested. The tractor will use this information to determine which lighting systems are functioning. Lighting controllers that have lamp sensing capability will also report failed light bulbs. This is a legal requirement in many areas.

See PGN 65089 for the lighting command message.

Transmission Repetition Rate: As requested.
 Data Length: 8
 Extended Data Page: 0
 Data Page: 0
 PDU Format: 254
 PDU Specific: 64 PGN Supporting Information:
 Default Priority: 6
 Parameter Group Number: 65088 (0xFE40)

Start Position	Length	Parameter Name	SPN
1.1	2 bits	Running Light	2404
1.3	2 bits	Alternate Beam Head Light Data	2352
1.5	2 bits	Low Beam Head Light Data	2350
1.7	2 bits	High Beam Head Light Data	2348
2.1	2 bits	Tractor Front Fog Lights	2388
2.3	2 bits	Rotating Beacon Light	2386
2.5	2 bits	Right Turn Signal Lights	2370
2.7	2 bits	Left Turn Signal Lights	2368
3.1	2 bits	Back Up Light and Alarm Horn	2392
3.3	2 bits	Center Stop Light	2376
3.5	2 bits	Right Stop Light	2374
3.7	2 bits	Left Stop Light	2372
4.1	2 bits	Implement Clearance Light	2384
4.3	2 bits	Tractor Clearance Light	2382
4.5	2 bits	Implement Marker Light	2380
4.7	2 bits	Tractor Marker Light	2378
5.1	2 bits	Rear Fog Lights	2390
5.3	2 bits	Tractor Underside Mounted Work Lights	2358
5.5	2 bits	Tractor Rear Low Mounted Work Lights	2360
5.7	2 bits	Tractor Rear High Mounted Work Lights	2362
6.1	2 bits	Tractor Side Low Mounted Work Lights	2364
6.3	2 bits	Tractor Side High Mounted Work Lights	2366
6.5	2 bits	Tractor Front Low Mounted Work Lights	2354
6.7	2 bits	Tractor Front High Mounted Work Lights	2356
7.1	2 bits	Implement OEM Option 2 Light	2398
7.3	2 bits	Implement OEM Option 1 Light	2396
7.5	2 bits	Implement Right Facing Work Light	2407
7.7	2 bits	Implement Left Facing Work Light	2598
8.3	2 bits	Implement Right Forward Work Light	2402
8.5	2 bits	Implement Left Forward Work Light	2400
8.7	2 bits	Implement Rear Work Light	2394

PGN 65089**Lighting Command****- LC**

The lighting command message has been defined as a global message from the tractor to all lighting controllers on the tractor and attached implements. Separate messages are provided for tractor and implement work and driving lights. Additional commands have been provided for 3 optional lights on implements to meet the needs of specialty equipment. Common marking and signaling messages are provided.

This message is used to control the state of all lighting functions. The lighting command message shall be sent on each change of state of a lamp. The state values indicate the lights is to be turned ON or OFF. Flashing is accomplished by sending the lighting message with the state alternately ON or OFF. A lighting command message must be sent at least once per second. It is the responsibility of the tractor designer to provide the correct combination of lamp commands to meet local legislative directives.

See PGN 65088 for the message to provide feedback for this command message.

Transmission Repetition Rate: On change of lamp on/ off state. Maximum period of 1 second between messages. No greater than 10 messages per second for all lights.

Data Length: 8
 Extended Data Page: 0
 Data Page: 0
 PDU Format: 254
 PDU Specific: 65 PGN Supporting Information:
 Default Priority: 3
 Parameter Group Number: 65089 (0xFE41)

Start Position	Length	Parameter Name	SPN
1.1	2 bits	Running Light Command	2403
1.3	2 bits	Alternate Beam Head Light Command	2351
1.5	2 bits	Low Beam Head Light Command	2349
1.7	2 bits	High Beam Head Light Command	2347
2.1	2 bits	Tractor Front Fog Lights Command	2387
2.3	2 bits	Rotating Beacon Light Command	2385
2.5	2 bits	Right Turn Signal Lights Command	2369
2.7	2 bits	Left Turn Signal Lights Command	2367
3.1	2 bits	Back Up Light and Alarm Horn Command	2391
3.3	2 bits	Center Stop Light Command	2375
3.5	2 bits	Right Stop Light Command	2373
3.7	2 bits	Left Stop Light Command	2371
4.1	2 bits	Implement Clearance Light Command	2383
4.3	2 bits	Tractor Clearance Light Command	2381
4.5	2 bits	Implement Marker Light Command	2379
4.7	2 bits	Tractor Marker Light Command	2377
5.1	2 bits	Rear Fog Light Command	2389
5.3	2 bits	Tractor Underside Mounted Work Lights Command	2357
5.5	2 bits	Tractor Rear Low Mounted Work Lights Command	2359
5.7	2 bits	Tractor Rear High Mounted Work Lights Command	2361
6.1	2 bits	Tractor Side Low Mounted Work Lights Command	2363
6.3	2 bits	Tractor Side High Mounted Work Lights Command	2365
6.5	2 bits	Tractor Front Low Mounted Work Lights Command	2353
6.7	2 bits	Tractor Front High Mounted Work Lights Command	2355
7.1	2 bits	Implement OEM Option 2 Light Command	2397
7.3	2 bits	Implement OEM Option 1 Light Command	2395
7.5	2 bits	Implement Right Facing Work Light Command	2406
7.7	2 bits	Implement Left Facing Work Light Command	2597
8.1	2 bits	Lighting Data Request Command	2393
8.3	2 bits	Implement Right Forward Work Light Command	2401
8.5	2 bits	Implement Left Forward Work Light Command	2399
8.7	2 bits	Implement Rear Work Light Command	2405

PGN 65098 (R) Electronic Transmission Controller 7**- ETC7**

Transmission status information from the transmission controller to network.

Transmission Repetition Rate: 100 ms
 Data Length: 8
 Extended Data Page: 0
 Data Page: 0
 PDU Format: 254
 PDU Specific: 74 PGN Supporting Information:
 Default Priority: 6
 Parameter Group Number: 65098 (0xFE4A)

Start Position	Length	Parameter Name	SPN
1.1	2 bits	Transmission Current Range Display Blank State	4176
1.3	2 bits	Transmission Service Indicator	4178
1.5	2 bits	Transmission Requested Range Display Blank State	1850
1.7	2 bits	Transmission Requested Range Display Flash State	1849
2.1	2 bits	Transmission Ready for Brake Release	3086
2.3	2 bits	Active Shift Console Indicator	2945
2.5	2 bits	Transmission Engine Crank Enable	2900
2.7	2 bits	Transmission Shift Inhibit Indicator	1851
3.1	2 bits	Transmission Mode 4 Indicator	2539
3.3	2 bits	Transmission Mode 3 Indicator	2538
3.5	2 bits	Transmission Mode 2 Indicator	2537
3.7	2 bits	Transmission Mode 1 Indicator	2536
4	1 byte	Transmission Requested Gear Feedback	3289
5.1	2 bits	Transmission Mode 5 Indicator	4250
5.3	2 bits	Transmission Mode 6 Indicator	4251
5.5	2 bits	Transmission Mode 7 Indicator	4252
5.7	2 bits	Transmission Mode 8 Indicator	4253
6.1	2 bits	Transmission Reverse Gear Shift Inhibit Status	4261

PGN 65099**Transmission Configuration 2****- TCFG2**

Contains transmission configuration information.

Transmission Repetition Rate: On request or sender may transmit every 5 seconds until acknowledged by reception of the engine configuration message PGN 65251 SPN 1846.

Data Length: Variable

Extended Data Page: 0

Data Page: 0

PDU Format: 254

PDU Specific: 75 PGN Supporting Information:

Default Priority: 6

Parameter Group Number: 65099 (0xFE4B)

Start Position	Length	Parameter Name	SPN
1-2	2 bytes	Transmission Torque Limit	1845

PGN 65100**Military Lighting Command****- ML**

The message contains parameters that control military specific lights.

Transmission Repetition Rate: 500ms or upon state change, but not faster than 100 ms.

Data Length: 8

Extended Data Page: 0

Data Page: 0

PDU Format: 254

PDU Specific: 76 PGN Supporting Information:

Default Priority: 6

Parameter Group Number: 65100 (0xFE4C)

Start Position	Length	Parameter Name	SPN
1.1	2 bits	Rear Black Out Marker Select	1840
1.3	2 bits	Front Black Out Marker Lamp Select	1839
1.5	2 bits	Convoy Lamp Select	1838
1.7	2 bits	Convoy Driving Lamp Select	1837
3.7	2 bits	Black Out Brake/Stop Lamp Select	1841
4.1	2 bits	Night Vision Illuminator Select	1843
4.7	2 bits	Black Out Work Lamp Select	1842
8	1 byte	Operators Black Out Intensity Selection	1844

PGN 65101**Total Averaged Information****- TAVG**

Averages of information accumulated over the life of the engine

Transmission Repetition Rate: On request
 Data Length: 8
 Extended Data Page: 0
 Data Page: 0
 PDU Format: 254
 PDU Specific: 77 PGN Supporting Information:
 Default Priority: 7
 Parameter Group Number: 65101 (0xFE4D)

Start Position	Length	Parameter Name	SPN
1-2	2 bytes	Engine Total Average Fuel Rate	1834
3-4	2 bytes	Engine Total Average Fuel Economy	1835

PGN 65102**Door Control 1****- DC1**

Used for door information.

Transmission Repetition Rate: 100 ms
 Data Length: 8
 Extended Data Page: 0
 Data Page: 0
 PDU Format: 254
 PDU Specific: 78 PGN Supporting Information:
 Default Priority: 6
 Parameter Group Number: 65102 (0xFE4E)

Start Position	Length	Parameter Name	SPN
1.1	4 bits	Position of doors	1821
1.5	2 bits	Ramp / Wheel Chair Lift Position	1820
1.7	2 bits	Status 2 of doors	3411

PGN 65103 Vehicle Dynamic Stability Control 1 - VDC1

Contains information which relates to the VDC system status.

Transmission Repetition Rate: 100ms
 Data Length: 8
 Extended Data Page: 0
 Data Page: 0
 PDU Format: 254
 PDU Specific: 79 PGN Supporting Information:
 Default Priority: 6
 Parameter Group Number: 65103 (0xFE4F)

Start Position	Length	Parameter Name	SPN
1.1	2 bits	VDC Information Signal	1813
1.3	2 bits	VDC Fully Operational	1814
1.5	2 bits	VDC brake light request	1815
2.1	2 bits	ROP Engine Control active	1816
2.3	2 bits	ROP Brake Control active	1818
2.5	2 bits	YC Engine Control active	1817
2.7	2 bits	YC Brake Control active	1819

PGN 65104 Battery Temperature - BT1

Contains battery temperature information.

Transmission Repetition Rate: 1 s
 Data Length: 8
 Extended Data Page: 0
 Data Page: 0
 PDU Format: 254
 PDU Specific: 80 PGN Supporting Information: See Appendix D - PGN 65104
 Default Priority: 6
 Parameter Group Number: 65104 (0xFE50)

Start Position	Length	Parameter Name	SPN
1	1 byte	Battery 1 Temperature	1800
2	1 byte	Battery 2 Temperature	1801

PGN 65105 Adaptive Cruise Control, Operator Input - ACC2

The operator requested characteristics for the ACC systems operation.

Transmission Repetition Rate: 250 ms
 Data Length: 8
 Extended Data Page: 0
 Data Page: 0
 PDU Format: 254
 PDU Specific: 81 PGN Supporting Information:
 Default Priority: 6
 Parameter Group Number: 65105 (0xFE51)

Start Position	Length	Parameter Name	SPN
1.6	3 bits	Requested ACC Distance Mode	1799

PGN 65106 Vehicle Electrical Power #3 - VEP3

This contains high resolution/range parameters reported from the alternator or power generation components.

Transmission Repetition Rate: 1 s
 Data Length: 8
 Extended Data Page: 0
 Data Page: 0
 PDU Format: 254
 PDU Specific: 82 PGN Supporting Information: See Appendix D - PGN 65104
 Default Priority: 6
 Parameter Group Number: 65106 (0xFE52)

Start Position	Length	Parameter Name	SPN
1-2	2 bytes	Alternator Current (High Range/Resolution)	1795
3-4	2 bytes	Net Battery Current (High Range/Resolution)	2579

PGN 65107 Retarder Continuous Torque & Speed Limit - RTC1

Transmission Repetition Rate: 5 s
 Data Length: 8
 Extended Data Page: 0
 Data Page: 0
 PDU Format: 254
 PDU Specific: 83 PGN Supporting Information:
 Default Priority: 6
 Parameter Group Number: 65107 (0xFE53)

Start Position	Length	Parameter Name	SPN
1	1 byte	Low Limit Threshold for Maximum RPM from Retarder	1776
2	1 byte	High Limit Threshold for Minimum Continuous RPM from Retarder	1777
3	1 byte	Low Limit Threshold for Maximum Torque from Retarder	1778
4	1 byte	High Limit Threshold for Minimum Continuous Torque from Retarder	1779
5	1 byte	Maximum Continuous Retarder Speed	1780
6	1 byte	Minimum Continuous Retarder Speed	1781
7	1 byte	Maximum Continuous Retarder Torque	1782
8	1 byte	Minimum Continuous Retarder Torque	1783

PGN 65108**Engine Continuous Torque & Speed Limit****- ECT1**

Transmission Repetition Rate: 5 s
 Data Length: 8
 Extended Data Page: 0
 Data Page: 0
 PDU Format: 254
 PDU Specific: 84 PGN Supporting Information:
 Default Priority: 6
 Parameter Group Number: 65108 (0xFE54)

Start Position	Length	Parameter Name	SPN
1	1 byte	Engine Low Limit Threshold for Maximum RPM from Engine	1768
2	1 byte	Engine High Limit Threshold for Minimum Continuous Engine RPM	1769
3	1 byte	Engine Low Limit Threshold for Maximum Torque from Engine	1770
4	1 byte	Engine High Limit Threshold for Minimum Continuous Torque from Engine	1771
5	1 byte	Engine Maximum Continuous RPM	1772
6	1 byte	Engine Minimum Continuous RPM	1773
7	1 byte	Engine Maximum Continuous Torque	1774
8	1 byte	Engine Minimum Continuous Torque	1775

PGN 65109**Gaseous Fuel Properties****- GFD**

Transmission Repetition Rate: On request
 Data Length: 8
 Extended Data Page: 0
 Data Page: 0
 PDU Format: 254
 PDU Specific: 85 PGN Supporting Information:
 Default Priority: 6
 Parameter Group Number: 65109 (0xFE55)

Start Position	Length	Parameter Name	SPN
1-2	2 bytes	Specific Heat Ratio	1767

PGN 65110**Tank Information 1****- T11**

Contains information on various tank levels

Transmission Repetition Rate: 1 s
 Data Length: 8
 Extended Data Page: 0
 Data Page: 0
 PDU Format: 254
 PDU Specific: 86 PGN Supporting Information:
 Default Priority: 6
 Parameter Group Number: 65110 (0xFE56)

Start Position	Length	Parameter Name	SPN
1	1 byte	Catalyst Tank Level	1761
2	1 byte	Catalyst Tank Temperature	3031
3-4	2 bytes	Catalyst Tank Level 2	3517
5.1	5 bits	Catalyst Tank Level Preliminary FMI	3532

PGN 65111**Air Suspension Control 5****- ASC5**

Used for damper stiffness information

Transmission Repetition Rate: 100 ms
 Data Length: 8
 Extended Data Page: 0
 Data Page: 0
 PDU Format: 254
 PDU Specific: 87 PGN Supporting Information:
 Default Priority: 3
 Parameter Group Number: 65111 (0xFE57)

Start Position	Length	Parameter Name	SPN
1	1 byte	Damper Stiffness Front Axle	1729
2	1 byte	Damper Stiffness Rear Axle	1730
3	1 byte	Damper Stiffness Lift / Tag Axle	1731
4.1	2 bits	Electronic Shock Absorber Control Mode - Front Axle	1833
4.3	2 bits	Electronic Shock Absorber Control Mode - Rear Axle	1832
4.5	2 bits	Electronic Shock Absorber Control Mode - Lift/Tag Axle	1831

PGN 65112**Air Suspension Control 4****- ASC4**

Used for bellow pressure information

Transmission Repetition Rate: 100 ms
 Data Length: 8
 Extended Data Page: 0
 Data Page: 0
 PDU Format: 254
 PDU Specific: 88 PGN Supporting Information:
 Default Priority: 6
 Parameter Group Number: 65112 (0xFE58)

Start Position	Length	Parameter Name	SPN
1-2	2 bytes	Bellow Pressure Front Axle Left	1725
3-4	2 bytes	Bellow Pressure Front Axle Right	1726
5-6	2 bytes	Bellow Pressure Rear Axle Left	1727
7-8	2 bytes	Bellow Pressure Rear Axle Right	1728

PGN 65113**Air Suspension Control 3****- ASC3**

Used for height information

Transmission Repetition Rate: 100 ms
 Data Length: 8
 Extended Data Page: 0
 Data Page: 0
 PDU Format: 254
 PDU Specific: 89 PGN Supporting Information:
 Default Priority: 6
 Parameter Group Number: 65113 (0xFE59)

Start Position	Length	Parameter Name	SPN
1-2	2 bytes	Relative Level Front Axle Left	1721
3-4	2 bytes	Relative Level Front Axle Right	1722
5-6	2 bytes	Relative Level Rear Axle Left	1724
7-8	2 bytes	Relative Level Rear Axle Right	1723

PGN 65114**Air Suspension Control 1****- ASC1**

Used for suspension control information

Transmission Repetition Rate: 100 ms
 Data Length: 8
 Extended Data Page: 0
 Data Page: 0
 PDU Format: 254
 PDU Specific: 90 PGN Supporting Information:
 Default Priority: 3
 Parameter Group Number: 65114 (0xFE5A)

Start Position	Length	Parameter Name	SPN
1.1	4 bits	Nominal Level Front Axle	1734
1.5	4 bits	Nominal Level Rear Axle	1733
2.1	2 bits	Below Nominal Level Front Axle	1738
2.3	2 bits	Below Nominal Level Rear Axle	1754
2.5	2 bits	Above Nominal Level Front Axle	1737
2.7	2 bits	Above Nominal Level Rear Axle	1736
3.1	2 bits	Lowering Control Mode Front Axle	1740
3.3	2 bits	Lowering Control Mode Rear Axle	1755
3.5	2 bits	Lifting Control Mode Front Axle	1739
3.7	2 bits	Lifting Control Mode Rear Axle	1756
4.1	4 bits	Kneeling Information	1742
4.5	4 bits	Level Control Mode	1741
5.1	2 bits	Security Device	1746
5.3	2 bits	Vehicle Motion Inhibit	1745
5.5	2 bits	Door Release	1744
5.7	2 bits	Lift Axle 1 Position	1743
6.1	2 bits	Front Axle in Bumper Range	1824
6.3	2 bits	Rear Axle in Bumper Range	1823
6.7	2 bits	Lift Axle 2 Position	1822
7.1	2 bits	Suspension Remote Control 1	1826
7.3	2 bits	Suspension Remote control 2	1825
8.1	4 bits	Suspension Control Refusal Information	1827

PGN 65115**Forward Lane Image****- FLI2**

Transmission Repetition Rate: 100 ms
 Data Length: 8
 Extended Data Page: 0
 Data Page: 0
 PDU Format: 254
 PDU Specific: 91 PGN Supporting Information:
 Default Priority: 6
 Parameter Group Number: 65115 (0xFE5B)

Start Position	Length	Parameter Name	SPN
1.3	2 bits	Lane Tracking Status Right Side	1711
1.5	2 bits	Lane Tracking Status Left Side	1710
1.7	2 bits	Lane Departure Indication Enable Status	1702

PGN 65126**Battery Main Switch Information****- BM**

Transmission Repetition Rate: 1 s
 Data Length: 8
 Extended Data Page: 0
 Data Page: 0
 PDU Format: 254
 PDU Specific: 102 PGN Supporting Information:
 Default Priority: 6
 Parameter Group Number: 65126 (0xFE66)

Start Position	Length	Parameter Name	SPN
1.1	2 bits	Battery Main Switch Hold State	1681

PGN 65127**Climate Control Configuration****- CCC**

Transmission Repetition Rate: On request
 Data Length: 8
 Extended Data Page: 0
 Data Page: 0
 PDU Format: 254
 PDU Specific: 103 PGN Supporting Information:
 Default Priority: 6
 Parameter Group Number: 65127 (0xFE67)

Start Position	Length	Parameter Name	SPN
1-2	2 bytes	Auxiliary Heater Maximum Output Power	1690

PGN 65128**Vehicle Fluids****- VF**

Transmission Repetition Rate: 1 s
 Data Length: 8
 Extended Data Page: 0
 Data Page: 0
 PDU Format: 254
 PDU Specific: 104 PGN Supporting Information:
 Default Priority: 6
 Parameter Group Number: 65128 (0xFE68)

Start Position	Length	Parameter Name	SPN
1	1 byte	Hydraulic Temperature	1638
2.1	2 bits	Hydraulic Oil Filter Restriction Switch	1713
2.3	2 bits	Winch Oil Pressure Switch	1857
3	1 byte	Hydraulic Oil Level	2602

PGN 65129**Engine Temperature 3****- ET3**

This parameter group is used to transmit high resolution engine temperatures for control purposes.

Transmission Repetition Rate: 1 s
 Data Length: 8
 Extended Data Page: 0
 Data Page: 0
 PDU Format: 254
 PDU Specific: 105 PGN Supporting Information:
 Default Priority: 6
 Parameter Group Number: 65129 (0xFE69)

Start Position	Length	Parameter Name	SPN
1-2	2 bytes	Engine Intake Manifold 1 Air Temperature (High Resolution)	1636
3-4	2 bytes	Engine Coolant Temperature (High Resolution)	1637
5-6	2 bytes	Engine Intake Valve Actuation System Oil Temperature	2986
7-8	2 bytes	Engine Charge Air Cooler Outlet Temperature	2630

PGN 65130**Engine Fuel/lube systems****- EFS**

Transmission Repetition Rate: 0.5 s
 Data Length: 8
 Extended Data Page: 0
 Data Page: 0
 PDU Format: 254
 PDU Specific: 106 PGN Supporting Information:
 Default Priority: 6
 Parameter Group Number: 65130 (0xFE6A)

Start Position	Length	Parameter Name	SPN
1	1 byte	Engine Oil Level Remote Reservoir	1380
2	1 byte	Engine Fuel Supply Pump Inlet Pressure	1381
3	1 byte	Engine Fuel Filter (suction side) Differential Pressure	1382
4	1 byte	Engine Waste Oil Reservoir Level	3548
5	1 byte	Engine Oil-Filter Outlet Pressure	3549
6.1	2 bits	Engine Oil Priming Pump Switch	3550
6.3	2 bits	Engine Oil Priming State	3551
6.5	2 bits	Engine Oil Pre-Heated State	3552
6.7	2 bits	Engine Coolant Pre-heated State	3553
7.1	3 bits	Engine Ventilation Status	3554
7.4	2 bits	Fuel Pump Primer Status	4083

PGN 65131**Driver's Identification****- DI**

Field:
 a Driver 1 Identification
 Delimiter (ASCII "**")
 b Driver 2 Identification
 Delimiter (ASCII "**")

NOTE - If only driver card 1 is present, only the parameter driver 1 identification and two delimiters shall be transmitted. If only driver card 2 is present, a delimiter followed by parameter driver 2 identification and the second delimiter shall be transmitted. If no driver cards are present, only the two delimiters shall be sent.

Transmission Repetition Rate: On request
 Data Length: Variable
 Extended Data Page: 0
 Data Page: 0
 PDU Format: 254
 PDU Specific: 107 PGN Supporting Information:
 Default Priority: 6
 Parameter Group Number: 65131 (0xFE6B)

Start Position	Length	Parameter Name	SPN
1-2	Variable ("**" delimited)	Driver 1 identification	1625
3-4	Variable ("**" delimited)	Driver 2 identification	1626

PGN 65132**Tachograph****- TCO1**

Transmission Repetition Rate: 50 ms
 Data Length: 8
 Extended Data Page: 0
 Data Page: 0
 PDU Format: 254
 PDU Specific: 108 PGN Supporting Information:
 Default Priority: 3
 Parameter Group Number: 65132 (0xFE6C)

Start Position	Length	Parameter Name	SPN
1.1	3 bits	Driver 1 working state	1612
1.4	3 bits	Driver 2 working state	1613
1.7	2 bits	Vehicle motion	1611
2.1	4 bits	Driver 1 Time Related States	1617
2.5	2 bits	Driver card, driver 1	1615
2.7	2 bits	Vehicle Overspeed	1614
3.1	4 bits	Driver 2 Time Related States	1618
3.5	2 bits	Driver card, driver 2	1616
4.1	2 bits	System event	1622
4.3	2 bits	Handling information	1621
4.5	2 bits	Tachograph performance	1620
4.7	2 bits	Direction indicator	1619
5-6	2 bytes	Tachograph output shaft speed	1623
7-8	2 bytes	Tachograph vehicle speed	1624

PGN 65133**Heater Information****- HTR**

Transmission Repetition Rate: 1 s
 Data Length: 8
 Extended Data Page: 0
 Data Page: 0
 PDU Format: 254
 PDU Specific: 109 PGN Supporting Information:
 Default Priority: 6
 Parameter Group Number: 65133 (0xFE6D)

Start Position	Length	Parameter Name	SPN
1	1 byte	Auxiliary Heater Output Coolant Temperature	1687
2	1 byte	Auxiliary Heater Input Air Temperature	1688
3	1 byte	Auxiliary Heater Output Power Percent	1689
4.1	4 bits	Auxiliary Heater Mode	1677
5.1	2 bits	Auxiliary Heater Water Pump Status	1676
5.3	2 bits	Cab Ventilation	1678
5.5	2 bits	Engine Heating Zone	1679
5.7	2 bits	Cab Heating Zone	1680

PGN 65134**High Resolution Wheel Speed****- HRW**

Transmission Repetition Rate: 20 ms
 Data Length: 8
 Extended Data Page: 0
 Data Page: 0
 PDU Format: 254
 PDU Specific: 110 PGN Supporting Information:
 Default Priority: 2
 Parameter Group Number: 65134 (0xFE6E)

Start Position	Length	Parameter Name	SPN
1-2	2 bytes	Front Axle, Left Wheel Speed	1592
3-4	2 bytes	Front axle, right wheel speed	1593
5-6	2 bytes	Rear axle, left wheel speed	1594
7-8	2 bytes	Rear axle, right wheel speed	1595

PGN 65135**Adaptive Cruise Control****- ACC1**

NOTE—The ACC1 message is required whenever the engine is running and ACC is powered on and not faulted. The timeout for ACC1 message will be between 2.5 times to 5 times the update rate.

The ACC1 message is intended primarily for engines and driver display units. The receiving device should identify the ACC device based on ACC function value of 32 (headway controller) or source address of 42 (headway controller).

In the event that the engine is running, the ACC is installed and the ACC1 message is not present, the engine will disable cruise control and return to non-cruise mode; also, the driver display unit will notify the driver that ACC operation is no longer available. In addition to the ACC1 timeout, engine cruise control will also be disabled if parameter "Adaptive Cruise Control State" in ACC1 is 110b (ACC disabled or in error). In some cases, it may be possible for the driver to restart cruise control (without ACC capability) during ACC/J1939 fault by performing a reset function. See Figure PGN65135_A.

It is possible that engines and driver display units may require calibration settings in order to know if the present vehicle configuration includes an ACC system or not. A calibration setting may also be needed for defining the driver reset function.

Transmission Repetition Rate: 100 ms
 Data Length: 8
 Extended Data Page: 0
 Data Page: 0
 PDU Format: 254
 PDU Specific: 111 PGN Supporting Information: See Appendix D - PGN 65135
 Default Priority: 4
 Parameter Group Number: 65135 (0xFE6F)

Start Position	Length	Parameter Name	SPN
1	1 byte	Speed of forward vehicle	1586
2	1 byte	Distance to forward vehicle	1587
3	1 byte	Adaptive Cruise Control Set Speed	1588
4.1	3 bits	Adaptive Cruise Control Mode	1590
4.4	3 bits	Adaptive cruise control set distance mode	1589
5-6	2 bytes	Road curvature	1591
7.1	2 bits	ACC Target Detected	1798
7.3	2 bits	ACC System Shutoff Warning	1797
7.5	2 bits	ACC Distance Alert Signal	1796

PGN 65136**Combination Vehicle Weight****- CVW**

Transmission Repetition Rate: On request
 Data Length: Variable
 Extended Data Page: 0
 Data Page: 0
 PDU Format: 254
 PDU Specific: 112 PGN Supporting Information:
 Default Priority: 6
 Parameter Group Number: 65136 (0xFE70)

Start Position	Length	Parameter Name	SPN
1-2	2 bytes	Powered Vehicle Weight	1585
3-4	2 bytes	Gross Combination Vehicle Weight	1760

PGN 65137**Laser Tracer Position****- LTP**

Transmission Repetition Rate: 50 ms
 Data Length: 8
 Extended Data Page: 0
 Data Page: 0
 PDU Format: 254
 PDU Specific: 113 PGN Supporting Information:
 Default Priority: 3
 Parameter Group Number: 65137 (0xFE71)

Start Position	Length	Parameter Name	SPN
1-2	2 bytes	Laser Tracer Target Deviation	1579
3-4	2 bytes	Laser Tracer Vertical Distance	1580
5	1 byte	Laser Tracer Horizontal Deviation	1581
6	8 bits	LED Display Data #2	1582
7	8 bits	Laser Tracer Information	1583

PGN 65138**Laser Leveling System Blade Control****- LBC**

Transmission Repetition Rate: 50 ms
 Data Length: 8
 Extended Data Page: 0
 Data Page: 0
 PDU Format: 254
 PDU Specific: 114 PGN Supporting Information:
 Default Priority: 3
 Parameter Group Number: 65138 (0xFE72)

Start Position	Length	Parameter Name	SPN
1-2	2 bytes	Blade Duration and Direction	1577
3	8 bits	Blade Control Mode	1578

PGN 65139**Laser Receiver Mast Position****- LMP**

Transmission Repetition Rate: 50 ms
 Data Length: 8
 Extended Data Page: 0
 Data Page: 0
 PDU Format: 254
 PDU Specific: 115 PGN Supporting Information:
 Default Priority: 3
 Parameter Group Number: 65139 (0xFE73)

Start Position	Length	Parameter Name	SPN
1-2	2 bytes	Mast Position	1576

PGN 65140**Modify Leveling System Control Set Point****- LSP**

Transmission Repetition Rate: 50 ms
 Data Length: 8
 Extended Data Page: 0
 Data Page: 0
 PDU Format: 254
 PDU Specific: 116 PGN Supporting Information:
 Default Priority: 3
 Parameter Group Number: 65140 (0xFE74)

Start Position	Length	Parameter Name	SPN
1-2	2 bytes	Modify Leveling System Set Point	1575
3-6	4 bytes	Blade Height Set Point - High Resolution	1759

PGN 65141 Laser Leveling System Vertical Deviation - LVD

Transmission Repetition Rate: 50 ms
 Data Length: 8
 Extended Data Page: 0
 Data Page: 0
 PDU Format: 254
 PDU Specific: 117 PGN Supporting Information:
 Default Priority: 3
 Parameter Group Number: 65141 (0xFE75)

Start Position	Length	Parameter Name	SPN
1-2	2 bytes	Laser Strike Vertical Deviation	1574
3	1 byte	Laser Receiver Type	2576
4-5	2 bytes	Laser Strike Data Latency	2793
6-7	2 bytes	Absolute Laser Strike Position	2794

PGN 65142 Laser Leveling System Vertical Position Display Data - LVDD

Transmission Repetition Rate: 100 ms
 Data Length: 8
 Extended Data Page: 0
 Data Page: 0
 PDU Format: 254
 PDU Specific: 118 PGN Supporting Information:
 Default Priority: 4
 Parameter Group Number: 65142 (0xFE76)

Start Position	Length	Parameter Name	SPN
1	8 bits	LED Display Data #1	1573
2.1	4 bits	LED Display Mode Control	1805
2.5	4 bits	LED Display Deadband Control	1806
3.1	4 bits	LED Pattern Control	2578
3.5	4 bits	Display Deadbands	2577

PGN 65143**Auxiliary Pressures****- AP**

Transmission Repetition Rate: On request
 Data Length: 8
 Extended Data Page: 0
 Data Page: 0
 PDU Format: 254
 PDU Specific: 119 PGN Supporting Information:
 Default Priority: 7
 Parameter Group Number: 65143 (0xFE77)

Start Position	Length	Parameter Name	SPN
1-2	2 bytes	Auxiliary Vacuum Pressure Reading	136
3-4	2 bytes	Auxiliary Gage Pressure Reading 1	137
5-6	2 bytes	Auxiliary Absolute Pressure Reading	138

PGN 65144**Tire Pressure Control Unit Mode and Status****- TP1**

Transmission Repetition Rate: On request
 Data Length: 8
 Extended Data Page: 0
 Data Page: 0
 PDU Format: 254
 PDU Specific: 120 PGN Supporting Information:
 Default Priority: 7
 Parameter Group Number: 65144 (0xFE78)

Start Position	Length	Parameter Name	SPN
1	1 byte	Tire Pressure Check Interval	39
2.1	4 bits	Steer Channel Mode	1466
3.1	4 bits	Trailer/tag Channel Mode	1467
3.5	4 bits	Drive Channel Mode	1468
4.1	2 bits	PCU Drive Solenoid Status	1469
4.3	2 bits	PCU Steer Solenoid Status	1470
4.5	2 bits	Tire Pressure Supply Switch Status	1471
5.1	2 bits	PCU Deflate Solenoid Status	1472
5.3	2 bits	PCU Control Solenoid Status	1473
5.5	2 bits	PCU Supply Solenoid Status	1474
5.7	2 bits	PCU Trailer, Tag or Push Solenoid Status	1475

PGN 65145**Tire Pressure Control Unit Target Pressures****- TP2**

Transmission Repetition Rate: On request

Data Length: 8

Extended Data Page: 0

Data Page: 0

PDU Format: 254

PDU Specific: 121 PGN Supporting Information:

Default Priority: 7

Parameter Group Number: 65145 (0xFE79)

Start Position	Length	Parameter Name	SPN
1-2	2 bytes	Trailer, Tag Or Push Channel Tire Pressure Target	141
3-4	2 bytes	Drive Channel Tire Pressure Target	142
5-6	2 bytes	Steer Channel Tire Pressure Target	143

PGN 65146**Tire Pressure Control Unit Current Pressures****- TP3**

Transmission Repetition Rate: On request

Data Length: 8

Extended Data Page: 0

Data Page: 0

PDU Format: 254

PDU Specific: 122 PGN Supporting Information:

Default Priority: 7

Parameter Group Number: 65146 (0xFE7A)

Start Position	Length	Parameter Name	SPN
1-2	2 bytes	Trailer, Tag Or Push Channel Tire Pressure	144
3-4	2 bytes	Drive Channel Tire Pressure	145
5-6	2 bytes	Steer Channel Tire Pressure	146

PGN 65147**Combustion Time 1****- CT1**

Transmission Repetition Rate: On request
 Data Length: 8
 Extended Data Page: 0
 Data Page: 0
 PDU Format: 254
 PDU Specific: 123 PGN Supporting Information:
 Default Priority: 7
 Parameter Group Number: 65147 (0xFE7B)

Start Position	Length	Parameter Name	SPN
1-2	2 bytes	Engine Cylinder #1 Combustion Time	1444
3-4	2 bytes	Engine Cylinder #2 Combustion Time	1445
5-6	2 bytes	Engine Cylinder #3 Combustion Time	1446
7-8	2 bytes	Engine Cylinder #4 Combustion Time	1447

PGN 65148**Combustion Time 2****- CT2**

Transmission Repetition Rate: On request
 Data Length: 8
 Extended Data Page: 0
 Data Page: 0
 PDU Format: 254
 PDU Specific: 124 PGN Supporting Information:
 Default Priority: 7
 Parameter Group Number: 65148 (0xFE7C)

Start Position	Length	Parameter Name	SPN
1-2	2 bytes	Engine Cylinder #5 Combustion Time	1448
3-4	2 bytes	Engine Cylinder #6 Combustion Time	1449
5-6	2 bytes	Engine Cylinder #7 Combustion Time	1450
7-8	2 bytes	Engine Cylinder #8 Combustion Time	1451

PGN 65149**Combustion Time 3****- CT3**

Transmission Repetition Rate: On request
 Data Length: 8
 Extended Data Page: 0
 Data Page: 0
 PDU Format: 254
 PDU Specific: 125 PGN Supporting Information:
 Default Priority: 7
 Parameter Group Number: 65149 (0xFE7D)

Start Position	Length	Parameter Name	SPN
1-2	2 bytes	Engine Cylinder #9 Combustion Time	1452
3-4	2 bytes	Engine Cylinder #10 Combustion Time	1453
5-6	2 bytes	Engine Cylinder #11 Combustion Time	1454
7-8	2 bytes	Engine Cylinder #12 Combustion Time	1455

PGN 65150**Combustion Time 4****- CT4**

Transmission Repetition Rate: On request
 Data Length: 8
 Extended Data Page: 0
 Data Page: 0
 PDU Format: 254
 PDU Specific: 126 PGN Supporting Information:
 Default Priority: 7
 Parameter Group Number: 65150 (0xFE7E)

Start Position	Length	Parameter Name	SPN
1-2	2 bytes	Engine Cylinder #13 Combustion Time	1456
3-4	2 bytes	Engine Cylinder #14 Combustion Time	1457
5-6	2 bytes	Engine Cylinder #15 Combustion Time	1458
7-8	2 bytes	Engine Cylinder #16 Combustion Time	1459

PGN 65151**Combustion Time 5****- CT5**

Transmission Repetition Rate: On request
 Data Length: 8
 Extended Data Page: 0
 Data Page: 0
 PDU Format: 254
 PDU Specific: 127 PGN Supporting Information:
 Default Priority: 7
 Parameter Group Number: 65151 (0xFE7F)

Start Position	Length	Parameter Name	SPN
1-2	2 bytes	Engine Cylinder #17 Combustion Time	1460
3-4	2 bytes	Engine Cylinder #18 Combustion Time	1461
5-6	2 bytes	Engine Cylinder #19 Combustion Time	1462
7-8	2 bytes	Engine Cylinder #20 Combustion Time	1463

PGN 65152**Combustion Time 6****- CT6**

Transmission Repetition Rate: On request
 Data Length: 8
 Extended Data Page: 0
 Data Page: 0
 PDU Format: 254
 PDU Specific: 128 PGN Supporting Information:
 Default Priority: 7
 Parameter Group Number: 65152 (0xFE80)

Start Position	Length	Parameter Name	SPN
1-2	2 bytes	Engine Desired Combustion Time	1464
3-4	2 bytes	Engine Average Combustion Time	1465

PGN 65153**Fuel Information 2 (Gaseous)****- GF12**

Gaseous fuel information 2

Transmission Repetition Rate: On request
 Data Length: 8
 Extended Data Page: 0
 Data Page: 0
 PDU Format: 254
 PDU Specific: 129 PGN Supporting Information:
 Default Priority: 7
 Parameter Group Number: 65153 (0xFE81)

Start Position	Length	Parameter Name	SPN
1-2	2 bytes	Engine Fuel Flow Rate 1	1440
3-4	2 bytes	Engine Fuel Flow Rate 2	1441
5	1 byte	Engine Fuel Valve 1 Position	1442
6	1 byte	Engine Fuel Valve 2 Position	1443
7	1 byte	Engine Requested Fuel Valve 1 Position	1765
8	1 byte	Engine Requested Fuel Valve 2 Position	1766

PGN 65154**Ignition Timing 1****- IT1**

Transmission Repetition Rate: On request
 Data Length: 8
 Extended Data Page: 0
 Data Page: 0
 PDU Format: 254
 PDU Specific: 130 PGN Supporting Information:
 Default Priority: 7
 Parameter Group Number: 65154 (0xFE82)

Start Position	Length	Parameter Name	SPN
1-2	2 bytes	Engine Cylinder #1 Ignition Timing	1413
3-4	2 bytes	Engine Cylinder #2 Ignition Timing	1414
5-6	2 bytes	Engine Cylinder #3 Ignition Timing	1415
7-8	2 bytes	Engine Cylinder #4 Ignition Timing	1416

PGN 65155**Ignition Timing 2****- IT2**

Transmission Repetition Rate: On request
 Data Length: 8
 Extended Data Page: 0
 Data Page: 0
 PDU Format: 254
 PDU Specific: 131 PGN Supporting Information:
 Default Priority: 7
 Parameter Group Number: 65155 (0xFE83)

Start Position	Length	Parameter Name	SPN
1-2	2 bytes	Engine Cylinder #5 Ignition Timing	1417
3-4	2 bytes	Engine Cylinder #6 Ignition Timing	1418
5-6	2 bytes	Engine Cylinder #7 Ignition Timing	1419
7-8	2 bytes	Engine Cylinder #8 Ignition Timing	1420

PGN 65156**Ignition Timing 3****- IT3**

Transmission Repetition Rate: On request
 Data Length: 8
 Extended Data Page: 0
 Data Page: 0
 PDU Format: 254
 PDU Specific: 132 PGN Supporting Information:
 Default Priority: 7
 Parameter Group Number: 65156 (0xFE84)

Start Position	Length	Parameter Name	SPN
1-2	2 bytes	Engine Cylinder #9 Ignition Timing	1421
3-4	2 bytes	Engine Cylinder #10 Ignition Timing	1422
5-6	2 bytes	Engine Cylinder #11 Ignition Timing	1423
7-8	2 bytes	Engine Cylinder #12 Ignition Timing	1424

PGN 65157**Ignition Timing 4****- IT4**

Transmission Repetition Rate: On request
 Data Length: 8
 Extended Data Page: 0
 Data Page: 0
 PDU Format: 254
 PDU Specific: 133 PGN Supporting Information:
 Default Priority: 7
 Parameter Group Number: 65157 (0xFE85)

Start Position	Length	Parameter Name	SPN
1-2	2 bytes	Engine Cylinder #13 Ignition Timing	1425
3-4	2 bytes	Engine Cylinder #14 Ignition Timing	1426
5-6	2 bytes	Engine Cylinder #15 Ignition Timing	1427
7-8	2 bytes	Engine Cylinder #16 Ignition Timing	1428

PGN 65158**Ignition Timing 5****- IT5**

Transmission Repetition Rate: On request
 Data Length: 8
 Extended Data Page: 0
 Data Page: 0
 PDU Format: 254
 PDU Specific: 134 PGN Supporting Information:
 Default Priority: 7
 Parameter Group Number: 65158 (0xFE86)

Start Position	Length	Parameter Name	SPN
1-2	2 bytes	Engine Cylinder #17 Ignition Timing	1429
3-4	2 bytes	Engine Cylinder #18 Ignition Timing	1430
5-6	2 bytes	Engine Cylinder #19 Ignition Timing	1431
7-8	2 bytes	Engine Cylinder #20 Ignition Timing	1432

PGN 65159**Ignition Timing 6****- IT6**

Transmission Repetition Rate: On request
 Data Length: 8
 Extended Data Page: 0
 Data Page: 0
 PDU Format: 254
 PDU Specific: 135 PGN Supporting Information:
 Default Priority: 7
 Parameter Group Number: 65159 (0xFE87)

Start Position	Length	Parameter Name	SPN
1-2	2 bytes	Engine Desired Ignition Timing #1	1433
3-4	2 bytes	Engine Desired Ignition Timing #2	1434
5-6	2 bytes	Engine Desired Ignition Timing #3	1435
7-8	2 bytes	Engine Actual Ignition Timing	1436

PGN 65160**Ignition Transformer Secondary Output 1****- ISO1**

Transmission Repetition Rate: On request
 Data Length: 8
 Extended Data Page: 0
 Data Page: 0
 PDU Format: 254
 PDU Specific: 136 PGN Supporting Information:
 Default Priority: 7
 Parameter Group Number: 65160 (0xFE88)

Start Position	Length	Parameter Name	SPN
1	1 byte	Engine Cylinder #1 Ignition Transformer Secondary Output	1393
2	1 byte	Engine Cylinder #2 Ignition Transformer Secondary Output	1394
3	1 byte	Engine Cylinder #3 Ignition Transformer Secondary Output	1395
4	1 byte	Engine Cylinder #4 Ignition Transformer Secondary Output	1396
5	1 byte	Engine Cylinder #5 Ignition Transformer Secondary Output	1397
6	1 byte	Engine Cylinder #6 Ignition Transformer Secondary Output	1398
7	1 byte	Engine Cylinder #7 Ignition Transformer Secondary Output	1399
8	1 byte	Engine Cylinder #8 Ignition Transformer Secondary Output	1400

PGN 65161**Ignition Transformer Secondary Output 2****- ISO2**

Transmission Repetition Rate: On request
 Data Length: 8
 Extended Data Page: 0
 Data Page: 0
 PDU Format: 254
 PDU Specific: 137 PGN Supporting Information:
 Default Priority: 7
 Parameter Group Number: 65161 (0xFE89)

Start Position	Length	Parameter Name	SPN
1	1 byte	Engine Cylinder #9 Ignition Transformer Secondary Output	1401
2	1 byte	Engine Cylinder #10 Ignition Transformer Secondary Output	1402
3	1 byte	Engine Cylinder #11 Ignition Transformer Secondary Output	1403
4	1 byte	Engine Cylinder #12 Ignition Transformer Secondary Output	1404
5	1 byte	Engine Cylinder #13 Ignition Transformer Secondary Output	1405
6	1 byte	Engine Cylinder #14 Ignition Transformer Secondary Output	1406
7	1 byte	Engine Cylinder #15 Ignition Transformer Secondary Output	1407
8	1 byte	Engine Cylinder #16 Ignition Transformer Secondary Output	1408

PGN 65162**Ignition Transformer Secondary Output 3****- ISO3**

Transmission Repetition Rate: On request
 Data Length: 8
 Extended Data Page: 0
 Data Page: 0
 PDU Format: 254
 PDU Specific: 138 PGN Supporting Information:
 Default Priority: 7
 Parameter Group Number: 65162 (0xFE8A)

Start Position	Length	Parameter Name	SPN
1	1 byte	Engine Cylinder #17 Ignition Transformer Secondary Output	1409
2	1 byte	Engine Cylinder #18 Ignition Transformer Secondary Output	1410
3	1 byte	Engine Cylinder #19 Ignition Transformer Secondary Output	1411
4	1 byte	Engine Cylinder #20 Ignition Transformer Secondary Output	1412

PGN 65163**Gaseous Fuel Pressure****- GFP**

Transmission Repetition Rate: On request
 Data Length: 8
 Extended Data Page: 0
 Data Page: 0
 PDU Format: 254
 PDU Specific: 139 PGN Supporting Information: See Appendix D - PGN 65163
 Default Priority: 7
 Parameter Group Number: 65163 (0xFE8B)

Start Position	Length	Parameter Name	SPN
1-2	2 bytes	Engine Fuel Valve 1 Inlet Absolute Pressure	1390
3-4	2 bytes	Engine Fuel Valve Differential Pressure	1391
5-6	2 bytes	Engine Air to Fuel Differential Pressure	1392
7-8	2 bytes	Engine Fuel Valve 1 Outlet Absolute Pressure	2980

PGN 65164**Auxiliary Analog Information****- AAI**

Auxiliary Analog Information

Transmission Repetition Rate: On request
 Data Length: 8
 Extended Data Page: 0
 Data Page: 0
 PDU Format: 254
 PDU Specific: 140 PGN Supporting Information:
 Default Priority: 7
 Parameter Group Number: 65164 (0xFE8C)

Start Position	Length	Parameter Name	SPN
1	1 byte	Auxiliary Temperature 1	441
2	1 byte	Auxiliary Temperature 2	442
3	1 byte	Auxiliary Pressure #1	1387
4	1 byte	Auxiliary Pressure #2	1388
5-6	2 bytes	Auxiliary Level	3087
7	1 byte	Relative Humidity	354

PGN 65165**Vehicle Electrical Power #2****- VEP2**

Voltage data for the main vehicle Power Distribution system.

Transmission Repetition Rate: On request
 Data Length: 8
 Extended Data Page: 0
 Data Page: 0
 PDU Format: 254
 PDU Specific: 141 PGN Supporting Information: See Appendix D - PGN 65104
 Default Priority: 6
 Parameter Group Number: 65165 (0xFE8D)

Start Position	Length	Parameter Name	SPN
1-2	2 bytes	Battery Potential / Power Input 2	444
3-4	2 bytes	ECU Power Output Supply Voltage #1	3597
5-6	2 bytes	ECU Power Output Supply Voltage #2	3598
7-8	2 bytes	ECU Power Output Supply Voltage #3	3599

PGN 65166**Service 2****- S2**

NOTE - There are two acceptable formats for the Service PGN. Format 1 has only 8 bytes of data and reports the component most in need of service for each of the three categories. Format 2, however, uses the transport protocol as necessary (See J1939-21) in order to repeat these 8 bytes of service component information until all supported service components in each category have been transmitted.

Transmission Repetition Rate: On request
 Data Length: 8
 Extended Data Page: 0
 Data Page: 0
 PDU Format: 254
 PDU Specific: 142 PGN Supporting Information:
 Default Priority: 7
 Parameter Group Number: 65166 (0xFE8E)

Start Position	Length	Parameter Name	SPN
1	1 byte	Service Component Identification	1379
2-3	2 bytes	Time Since Last Service	1350

PGN 65167**Supply Pressure 2****- SP2**

Transmission Repetition Rate: 1 s
 Data Length: 8
 Extended Data Page: 0
 Data Page: 0
 PDU Format: 254
 PDU Specific: 143 PGN Supporting Information:
 Default Priority: 6
 Parameter Group Number: 65167 (0xFE8F)

Start Position	Length	Parameter Name	SPN
1-2	2 bytes	Engine External Shutdown Air Supply Pressure	1320

PGN 65168**Engine Torque History****- ETH**

NOTE - The torque history PGN is variable in length and may contain up to 125 torque history records. Each torque history record MUST BE 38 bytes in length. Any unused bytes must be 0xFF.

The last six bytes of each record are not currently defined and shall be transmitted as "not available" (0xff). In the first record, these are byte positions 34-39.

Transmission Repetition Rate: On request
 Data Length: Variable
 Extended Data Page: 0
 Data Page: 0
 PDU Format: 254
 PDU Specific: 144 PGN Supporting Information:
 Default Priority: 6
 Parameter Group Number: 65168 (0xFE90)

Start Position	Length	Parameter Name	SPN
01	1 byte	Number of Engine Torque History Records	1246
02-03	2 bytes	Engine Power	1247
04-05	2 bytes	Engine Peak Torque 1	1248
06-07	2 bytes	Engine Peak Torque 2	1249
08	1 byte	Calibration Record Start Month	1250
09	1 byte	Calibration Record Start Day	1251
10	1 byte	Calibration Record Start Year	1252
11-14	4 bytes	Calibration Record Duration Time	1253
15.1	2 bits	Torque Limiting Feature Status	1254
15.3	3 bits	Engine Torque Limit Feature	1632
16-17	2 bytes	Transmission Gear Ratio 1	1255
18-19	2 bytes	Engine Torque Limit 1, Transmission	1256
20-21	2 bytes	Transmission Gear Ratio 2	1257
22-23	2 bytes	Engine Torque Limit 2, Transmission	1258
24-25	2 bytes	Transmission Gear Ratio 3	1259
26-27	2 bytes	Engine Torque Limit 3, Transmission	1260
28-29	2 bytes	Engine Torque Limit 4, Transmission	1261
30-31	2 bytes	Engine Torque Limit 5, Switch	1262
32-33	2 bytes	Engine Torque Limit 6, Axle Input	1263

PGN 65169**Fuel Leakage****- FL**

Transmission Repetition Rate: 1 s
 Data Length: 8
 Extended Data Page: 0
 Data Page: 0
 PDU Format: 254
 PDU Specific: 145 PGN Supporting Information:
 Default Priority: 7
 Parameter Group Number: 65169 (0xFE91)

Start Position	Length	Parameter Name	SPN
1.1	2 bits	Engine Fuel Leakage 1	1239
1.3	2 bits	Engine Fuel Leakage 2	1240

PGN 65170**Engine Information****- EI**

Transmission Repetition Rate: 100 ms
 Data Length: 8
 Extended Data Page: 0
 Data Page: 0
 PDU Format: 254
 PDU Specific: 146 PGN Supporting Information:
 Default Priority: 7
 Parameter Group Number: 65170 (0xFE92)

Start Position	Length	Parameter Name	SPN
1	1 byte	Engine Pre-filter Oil Pressure	1208
2-3	2 bytes	Engine Exhaust Gas Pressure	1209
4	1 byte	Engine Fuel Rack Position	1210
5-6	2 bytes	Engine Gas Mass Flow Rate 1	1241
7-8	2 bytes	Instantaneous Estimated Brake Power	1242

PGN 65171**Engine Electrical System/Module Information****- EES**

Transmission Repetition Rate: 100 ms
 Data Length: 8
 Extended Data Page: 0
 Data Page: 0
 PDU Format: 254
 PDU Specific: 147 PGN Supporting Information: See Appendix D - PGN 65104
 Default Priority: 7
 Parameter Group Number: 65171 (0xFE93)

Start Position	Length	Parameter Name	SPN
1-2	2 bytes	Electrical Load	1204
3.1	2 bits	Safety Wire Status	1205

PGN 65172**Engine Auxiliary Coolant****- EAC**

Transmission Repetition Rate: 0.5 s
 Data Length: 8
 Extended Data Page: 0
 Data Page: 0
 PDU Format: 254
 PDU Specific: 148 PGN Supporting Information:
 Default Priority: 6
 Parameter Group Number: 65172 (0xFE94)

Start Position	Length	Parameter Name	SPN
1	1 byte	Engine Auxiliary Coolant Pressure	1203
2	1 byte	Engine Auxiliary Coolant Temperature	1212
3	1 byte	Sea Water Pump Outlet Pressure	2435

PGN 65173**Rebuild Information****- RBI**

Transmission Repetition Rate: On request
 Data Length: 8
 Extended Data Page: 0
 Data Page: 0
 PDU Format: 254
 PDU Specific: 149 PGN Supporting Information:
 Default Priority: 7
 Parameter Group Number: 65173 (0xFE95)

Start Position	Length	Parameter Name	SPN
1-4	4 bytes	Engine Operation Time Since Rebuild	1193

PGN 65174**Turbocharger Wastegate****- TCW**

Transmission Repetition Rate: 100 ms
 Data Length: 8
 Extended Data Page: 0
 Data Page: 0
 PDU Format: 254
 PDU Specific: 150 PGN Supporting Information:
 Default Priority: 6
 Parameter Group Number: 65174 (0xFE96)

Start Position	Length	Parameter Name	SPN
1	1 byte	Engine Turbocharger 1 Wastegate Drive	1188
2	1 byte	Engine Turbocharger 2 Wastegate Drive	1189
3	1 byte	Engine Turbocharger 3 Wastegate Drive	1190
4	1 byte	Engine Turbocharger 4 Wastegate Drive	1191
5	1 byte	Engine Turbocharger Wastegate Actuator Control Air Pressure	1192

PGN 65175**Turbocharger Information 5****- TC15**

Transmission Repetition Rate: 1 s
 Data Length: 8
 Extended Data Page: 0
 Data Page: 0
 PDU Format: 254
 PDU Specific: 151 PGN Supporting Information:
 Default Priority: 6
 Parameter Group Number: 65175 (0xFE97)

Start Position	Length	Parameter Name	SPN
1-2	2 bytes	Engine Turbocharger 1 Turbine Outlet Temperature	1184
3-4	2 bytes	Engine Turbocharger 2 Turbine Outlet Temperature	1185
5-6	2 bytes	Engine Turbocharger 3 Turbine Outlet Temperature	1186
7-8	2 bytes	Engine Turbocharger 4 Turbine Outlet Temperature	1187

PGN 65176**Turbocharger Information 4****- TC14**

Transmission Repetition Rate: 1 s
 Data Length: 8
 Extended Data Page: 0
 Data Page: 0
 PDU Format: 254
 PDU Specific: 152 PGN Supporting Information:
 Default Priority: 6
 Parameter Group Number: 65176 (0xFE98)

Start Position	Length	Parameter Name	SPN
1-2	2 bytes	Engine Turbocharger 1 Turbine Inlet Temperature	1180
3-4	2 bytes	Engine Turbocharger 2 Turbine Inlet Temperature	1181
5-6	2 bytes	Engine Turbocharger 3 Turbine Inlet Temperature	1182
7-8	2 bytes	Engine Turbocharger 4 Turbine Inlet Temperature	1183

PGN 65177**Turbocharger Information 3****- TCI3**

Transmission Repetition Rate: 1 s
 Data Length: 8
 Extended Data Page: 0
 Data Page: 0
 PDU Format: 254
 PDU Specific: 153 PGN Supporting Information:
 Default Priority: 6
 Parameter Group Number: 65177 (0xFE99)

Start Position	Length	Parameter Name	SPN
1-2	2 bytes	Engine Turbocharger 1 Compressor Inlet Pressure	1176
3-4	2 bytes	Engine Turbocharger 2 Compressor Inlet Pressure	1177
5-6	2 bytes	Engine Turbocharger 3 Compressor Inlet Pressure	1178
7-8	2 bytes	Engine Turbocharger 4 Compressor Inlet Pressure	1179

PGN 65178**(R) Turbocharger Information 2****- TCI2**

Transmission Repetition Rate: 1 s
 Data Length: 8
 Extended Data Page: 0
 Data Page: 0
 PDU Format: 254
 PDU Specific: 154 PGN Supporting Information:
 Default Priority: 6
 Parameter Group Number: 65178 (0xFE9A)

Start Position	Length	Parameter Name	SPN
1-2	2 bytes	Engine Turbocharger 1 Compressor Inlet Temperature	1172
3-4	2 bytes	Engine Turbocharger 2 Compressor Inlet Temperature	1173
5-6	2 bytes	Engine Turbocharger 3 Compressor Inlet Temperature	1174
7-8	2 bytes	Engine Turbocharger 4 Compressor Inlet Temperature	1175

PGN 65179**Turbocharger Information 1****- TCI1**

Transmission Repetition Rate: 1 s
 Data Length: 8
 Extended Data Page: 0
 Data Page: 0
 PDU Format: 254
 PDU Specific: 155 PGN Supporting Information:
 Default Priority: 7
 Parameter Group Number: 65179 (0xFE9B)

Start Position	Length	Parameter Name	SPN
1	1 byte	Engine Turbocharger Lube Oil Pressure 2	1168
2-3	2 bytes	Engine Turbocharger 2 Speed	1169
4-5	2 bytes	Engine Turbocharger 3 Speed	1170
6-7	2 bytes	Engine Turbocharger 4 Speed	1171

PGN 65180**Main Bearing Temperature 3****- MBT3**

Transmission Repetition Rate: 1 s
 Data Length: 8
 Extended Data Page: 0
 Data Page: 0
 PDU Format: 254
 PDU Specific: 156 PGN Supporting Information:
 Default Priority: 6
 Parameter Group Number: 65180 (0xFE9C)

Start Position	Length	Parameter Name	SPN
1-2	2 bytes	Engine Main Bearing 9 Temperature	1165
3-4	2 bytes	Engine Main Bearing 10 Temperature	1166
5-6	2 bytes	Engine Main Bearing 11 Temperature	1167

PGN 65181**Main Bearing Temperature 2****- MBT2**

Transmission Repetition Rate: 1 s
 Data Length: 8
 Extended Data Page: 0
 Data Page: 0
 PDU Format: 254
 PDU Specific: 157 PGN Supporting Information:
 Default Priority: 6
 Parameter Group Number: 65181 (0xFE9D)

Start Position	Length	Parameter Name	SPN
1-2	2 bytes	Engine Main Bearing 5 Temperature	1161
3-4	2 bytes	Engine Main Bearing 6 Temperature	1162
5-6	2 bytes	Engine Main Bearing 7 Temperature	1163
7-8	2 bytes	Engine Main Bearing 8 Temperature	1164

PGN 65182**Main Bearing Temperature 1****- MBT1**

Transmission Repetition Rate: 1 s
 Data Length: 8
 Extended Data Page: 0
 Data Page: 0
 PDU Format: 254
 PDU Specific: 158 PGN Supporting Information:
 Default Priority: 6
 Parameter Group Number: 65182 (0xFE9E)

Start Position	Length	Parameter Name	SPN
1-2	2 bytes	Engine Main Bearing 1 Temperature	1157
3-4	2 bytes	Engine Main Bearing 2 Temperature	1158
5-6	2 bytes	Engine Main Bearing 3 Temperature	1159
7-8	2 bytes	Engine Main Bearing 4 Temperature	1160

PGN 65183**Exhaust Port Temperature 5****- EPT5**

Transmission Repetition Rate: 1 s
 Data Length: 8
 Extended Data Page: 0
 Data Page: 0
 PDU Format: 254
 PDU Specific: 159 PGN Supporting Information:
 Default Priority: 7
 Parameter Group Number: 65183 (0xFE9F)

Start Position	Length	Parameter Name	SPN
1-2	2 bytes	Engine Exhaust Gas Port 17 Temperature	1153
3-4	2 bytes	Engine Exhaust Gas Port 18 Temperature	1154
5-6	2 bytes	Engine Exhaust Gas Port 19 Temperature	1155
7-8	2 bytes	Engine Exhaust Gas Port 20 Temperature	1156

PGN 65184**Exhaust Port Temperature 4****- EPT4**

Transmission Repetition Rate: 1 s
 Data Length: 8
 Extended Data Page: 0
 Data Page: 0
 PDU Format: 254
 PDU Specific: 160 PGN Supporting Information:
 Default Priority: 6
 Parameter Group Number: 65184 (0xFE A0)

Start Position	Length	Parameter Name	SPN
1-2	2 bytes	Engine Exhaust Gas Port 13 Temperature	1149
3-4	2 bytes	Engine Exhaust Gas Port 14 Temperature	1150
5-6	2 bytes	Engine Exhaust Gas Port 15 Temperature	1151
7-8	2 bytes	Engine Exhaust Gas Port 16 Temperature	1152

PGN 65185**Exhaust Port Temperature 3****- EPT3**

Transmission Repetition Rate: 1 s
 Data Length: 8
 Extended Data Page: 0
 Data Page: 0
 PDU Format: 254
 PDU Specific: 161 PGN Supporting Information:
 Default Priority: 7
 Parameter Group Number: 65185 (0xFE A1)

Start Position	Length	Parameter Name	SPN
1-2	2 bytes	Engine Exhaust Gas Port 9 Temperature	1145
3-4	2 bytes	Engine Exhaust Gas Port 10 Temperature	1146
5-6	2 bytes	Engine Exhaust Gas Port 11 Temperature	1147
7-8	2 bytes	Engine Exhaust Gas Port 12 Temperature	1148

PGN 65186**Exhaust Port Temperature 2****- EPT2**

Transmission Repetition Rate: 1 s
 Data Length: 8
 Extended Data Page: 0
 Data Page: 0
 PDU Format: 254
 PDU Specific: 162 PGN Supporting Information:
 Default Priority: 7
 Parameter Group Number: 65186 (0xFE A2)

Start Position	Length	Parameter Name	SPN
1-2	2 bytes	Engine Exhaust Gas Port 5 Temperature	1141
3-4	2 bytes	Engine Exhaust Gas Port 6 Temperature	1142
5-6	2 bytes	Engine Exhaust Gas Port 7 Temperature	1143
7-8	2 bytes	Engine Exhaust Gas Port 8 Temperature	1144

PGN 65187**Exhaust Port Temperature 1****- EPT1**

Transmission Repetition Rate: 1 s
 Data Length: 8
 Extended Data Page: 0
 Data Page: 0
 PDU Format: 254
 PDU Specific: 163 PGN Supporting Information:
 Default Priority: 7
 Parameter Group Number: 65187 (0xFE A3)

Start Position	Length	Parameter Name	SPN
1-2	2 bytes	Engine Exhaust Gas Port 1 Temperature	1137
3-4	2 bytes	Engine Exhaust Gas Port 2 Temperature	1138
5-6	2 bytes	Engine Exhaust Gas Port 3 Temperature	1139
7-8	2 bytes	Engine Exhaust Gas Port 4 Temperature	1140

PGN 65188**Engine Temperature 2****- ET2**

Transmission Repetition Rate: 1s
 Data Length: 8
 Extended Data Page: 0
 Data Page: 0
 PDU Format: 254
 PDU Specific: 164 PGN Supporting Information:
 Default Priority: 6
 Parameter Group Number: 65188 (0xFE A4)

Start Position	Length	Parameter Name	SPN
1-2	2 bytes	Engine Oil Temperature 2	1135
3-4	2 bytes	Engine ECU Temperature	1136
5-6	2 bytes	Engine Exhaust Gas Recirculation Differential Pressure	411
7-8	2 bytes	Engine Exhaust Gas Recirculation Temperature	412

PGN 65189**Intake Manifold Information 2****- IMT2**

Transmission Repetition Rate: 1 s
 Data Length: 8
 Extended Data Page: 0
 Data Page: 0
 PDU Format: 254
 PDU Specific: 165 PGN Supporting Information:
 Default Priority: 7
 Parameter Group Number: 65189 (0xFE A5)

Start Position	Length	Parameter Name	SPN
1	1 byte	Engine Intake Manifold 2 Temperature	1131
2	1 byte	Engine Intake Manifold 3 Temperature	1132
3	1 byte	Engine Intake Manifold 4 Temperature	1133
4	1 byte	Engine Intake Manifold 5 Temperature	1802
5	1 byte	Engine Intake Manifold 6 Temperature	1803

PGN 65190**Intake Manifold Information 1****- IMT1**

Transmission Repetition Rate: 0.5 s
 Data Length: 8
 Extended Data Page: 0
 Data Page: 0
 PDU Format: 254
 PDU Specific: 166 PGN Supporting Information:
 Default Priority: 6
 Parameter Group Number: 65190 (0xFE A6)

Start Position	Length	Parameter Name	SPN
1-2	2 bytes	Engine Turbocharger 1 Boost Pressure	1127
3-4	2 bytes	Engine Turbocharger 2 Boost Pressure	1128
5-6	2 bytes	Engine Turbocharger 3 Boost Pressure	1129
7-8	2 bytes	Engine Turbocharger 4 Boost Pressure	1130

PGN 65191**Alternator Temperature****- AT**

Transmission Repetition Rate: 1 s
 Data Length: 8
 Extended Data Page: 0
 Data Page: 0
 PDU Format: 254
 PDU Specific: 167 PGN Supporting Information:
 Default Priority: 7
 Parameter Group Number: 65191 (0xFE A7)

Start Position	Length	Parameter Name	SPN
1	1 byte	Engine Alternator Bearing 1 Temperature	1122
2	1 byte	Engine Alternator Bearing 2 Temperature	1123
3	1 byte	Engine Alternator Winding 1 Temperature	1124
4	1 byte	Engine Alternator Winding 2 Temperature	1125
5	1 byte	Engine Alternator Winding 3 Temperature	1126

PGN 65192**Articulation Control****- AC**

Transmission Repetition Rate: On request
 Data Length: 8
 Extended Data Page: 0
 Data Page: 0
 PDU Format: 254
 PDU Specific: 168 PGN Supporting Information:
 Default Priority: 7
 Parameter Group Number: 65192 (0xFE A8)

Start Position	Length	Parameter Name	SPN
1	1 byte	Articulation Angle	1120

PGN 65193**Exhaust Oxygen 1****- E01**

Transmission Repetition Rate: On request
 Data Length: 8
 Extended Data Page: 0
 Data Page: 0
 PDU Format: 254
 PDU Specific: 169 PGN Supporting Information:
 Default Priority: 7
 Parameter Group Number: 65193 (0xFEAA9)

Start Position	Length	Parameter Name	SPN
1-2	2 bytes	Engine Desired Rated Exhaust Oxygen	1117
3-4	2 bytes	Engine Desired Exhaust Oxygen	1118
5-6	2 bytes	Engine Actual Exhaust Oxygen	1119
7	1 byte	Engine Exhaust Gas Oxygen Sensor Fueling Correction	1695
8.7	2 bits	Engine Exhaust Gas Oxygen Sensor Closed Loop Operation	1696

PGN 65194**Alternate Fuel 2****- AF2**

Transmission Repetition Rate: On request
 Data Length: 8
 Extended Data Page: 0
 Data Page: 0
 PDU Format: 254
 PDU Specific: 170 PGN Supporting Information:
 Default Priority: 7
 Parameter Group Number: 65194 (0xFEAA)

Start Position	Length	Parameter Name	SPN
1	1 byte	Engine Gaseous Fuel Correction Factor	1116
2-3	2 bytes	Engine Desired Absolute Intake Manifold Pressure (Turbo Boost Limit)	1692
4	1 byte	Engine Turbocharger Wastegate Valve Position	1693
5	1 byte	Engine Gas Mass Flow Sensor Fueling Correction	1694

PGN 65195**Electronic Transmission Controller 6****- ETC6**

Transmission Repetition Rate: On request
 Data Length: 8
 Extended Data Page: 0
 Data Page: 0
 PDU Format: 254
 PDU Specific: 171 PGN Supporting Information:
 Default Priority: 7
 Parameter Group Number: 65195 (0xFEAB)

Start Position	Length	Parameter Name	SPN
1	1 byte	Recommended Gear	1113
2	1 byte	Highest Possible Gear	1115
3	1 byte	Lowest Possible Gear	1114
4	1 byte	Clutch Life Remaining	2983

PGN 65196**Wheel Brake Lining Remaining Information****- EBC4**

Transmission Repetition Rate: On request
 Data Length: 8
 Extended Data Page: 0
 Data Page: 0
 PDU Format: 254
 PDU Specific: 172 PGN Supporting Information:
 Default Priority: 7
 Parameter Group Number: 65196 (0xFEAC)

Start Position	Length	Parameter Name	SPN
1	1 byte	Brake Lining Remaining, Front Axle, Left Wheel	1099
2	1 byte	Brake Lining Remaining, Front Axle, Right Wheel	1100
3	1 byte	Brake Lining Remaining, Rear Axle #1, Left Wheel	1101
4	1 byte	Brake Lining Remaining, Rear Axle #1, Right Wheel	1102
5	1 byte	Brake Lining Remaining, Rear Axle #2, Left Wheel	1103
6	1 byte	Brake Lining Remaining, Rear Axle #2, Right Wheel	1104
7	1 byte	Brake Lining Remaining, Rear Axle #3, Left Wheel	1105
8	1 byte	Brake Lining Remaining, Rear Axle #3, Right Wheel	1106

PGN 65197**Wheel Application Pressure High Range Information****- EBC3**

Transmission Repetition Rate: 100 ms
 Data Length: 8
 Extended Data Page: 0
 Data Page: 0
 PDU Format: 254
 PDU Specific: 173 PGN Supporting Information:
 Default Priority: 6
 Parameter Group Number: 65197 (0xFEAD)

Start Position	Length	Parameter Name	SPN
1	1 byte	Brake Application Pressure High Range, Front Axle, Left Wheel	1091
2	1 byte	Brake Application Pressure High Range, Front Axle, Right Wheel	1092
3	1 byte	Brake Application Pressure High Range, Rear Axle #1, Left Wheel	1093
4	1 byte	Brake Application Pressure High Range, Rear Axle #1, Right Wheel	1094
5	1 byte	Brake Application Pressure High Range, Rear Axle #2, Left Wheel	1095
6	1 byte	Brake Application Pressure High Range, Rear Axle #2, Right Wheel	1096
7	1 byte	Brake Application Pressure High Range, Rear Axle #3, Left Wheel	1097
8	1 byte	Brake Application Pressure High Range, Rear Axle #3, Right Wheel	1098

PGN 65198**Air Supply Pressure****- AIR1**

Air Supply Pressure

Transmission Repetition Rate: 1 sec
 Data Length: 8
 Extended Data Page: 0
 Data Page: 0
 PDU Format: 254
 PDU Specific: 174 PGN Supporting Information:
 Default Priority: 6
 Parameter Group Number: 65198 (0xFEAE)

Start Position	Length	Parameter Name	SPN
1	1 byte	Pneumatic Supply Pressure	46
2	1 byte	Parking and/or Trailer Air Pressure	1086
3	1 byte	Service Brake Circuit 1 Air Pressure	1087
4	1 byte	Service Brake Circuit 2 Air Pressure	1088
5	1 byte	Auxiliary Equipment Supply Pressure	1089
6	1 byte	Air Suspension Supply Pressure	1090
7.1	2 bits	Air Compressor Status	1351

PGN 65199**Fuel Consumption (Gaseous)****- GFC**

Transmission Repetition Rate: On request
 Data Length: 8
 Extended Data Page: 0
 Data Page: 0
 PDU Format: 254
 PDU Specific: 175 PGN Supporting Information:
 Default Priority: 7
 Parameter Group Number: 65199 (0xFEAF)

Start Position	Length	Parameter Name	SPN
1-4	4 bytes	Trip Fuel (Gaseous)	1039
5-8	4 bytes	Total Fuel Used (Gaseous)	1040

PGN 65200**Trip Time Information 2****- TT12**

Transmission Repetition Rate: On request
 Data Length: 20
 Extended Data Page: 0
 Data Page: 0
 PDU Format: 254
 PDU Specific: 176 PGN Supporting Information:
 Default Priority: 7
 Parameter Group Number: 65200 (0xFEB0)

Start Position	Length	Parameter Name	SPN
01-04	4 bytes	Trip Cruise Time	1034
05-08	4 bytes	Trip PTO Governor Time	1035
09-12	4 bytes	Trip Engine Running Time	1036
13-16	4 bytes	Trip Idle Time	1037
17-20	4 bytes	Trip Air Compressor On Time	1038

PGN 65201**ECU History****- EH**

Transmission Repetition Rate: On request

Data Length: 8

Extended Data Page: 0

Data Page: 0

PDU Format: 254

PDU Specific: 177 PGN Supporting Information:

Default Priority: 7

Parameter Group Number: 65201 (0xFEB1)

Start Position	Length	Parameter Name	SPN
1-4	4 bytes	Total ECU Distance	1032
5-8	4 bytes	Total ECU Run Time	1033

PGN 65202**Fuel Information 1 (Gaseous)****- GF11**

Transmission Repetition Rate: On request

Data Length: 8

Extended Data Page: 0

Data Page: 0

PDU Format: 254

PDU Specific: 178 PGN Supporting Information:

Default Priority: 7

Parameter Group Number: 65202 (0xFEB2)

Start Position	Length	Parameter Name	SPN
1-4	4 bytes	Total Engine PTO Governor Fuel Used (Gaseous)	1030
5-6	2 bytes	Trip Average Fuel Rate (Gaseous)	1031
7-8	2 bytes	Engine Fuel Specific Gravity	1389

PGN 65203**Fuel Information (Liquid)****- LFI**

Transmission Repetition Rate: On request
 Data Length: 8
 Extended Data Page: 0
 Data Page: 0
 PDU Format: 254
 PDU Specific: 179 PGN Supporting Information:
 Default Priority: 7
 Parameter Group Number: 65203 (0xFEB3)

Start Position	Length	Parameter Name	SPN
1-4	4 bytes	Total Engine PTO Governor Fuel Used	1028
5-6	2 bytes	Trip Average Fuel Rate	1029

PGN 65204**Trip Time Information 1****- TTI1**

Transmission Repetition Rate: On request
 Data Length: 16
 Extended Data Page: 0
 Data Page: 0
 PDU Format: 254
 PDU Specific: 180 PGN Supporting Information:
 Default Priority: 7
 Parameter Group Number: 65204 (0xFEB4)

Start Position	Length	Parameter Name	SPN
01-04	4 bytes	Trip Time in VSL	1024
05-08	4 bytes	Trip Time in Top Gear	1025
09-12	4 bytes	Trip Time in Gear Down	1026
13-16	4 bytes	Trip Time in Derate by Engine	1027

PGN 65205**Trip Shutdown Information****- TSI**

Transmission Repetition Rate: On request
 Data Length: 8
 Extended Data Page: 0
 Data Page: 0
 PDU Format: 254
 PDU Specific: 181 PGN Supporting Information:
 Default Priority: 7
 Parameter Group Number: 65205 (0xFEB5)

Start Position	Length	Parameter Name	SPN
1-2	2 bytes	Trip Number of Hot Shutdowns	1020
3-4	2 bytes	Trip Number of Idle Shutdowns	1021
5-6	2 bytes	Trip Number of Idle Shutdown Overrides	1022
7-8	2 bytes	Trip Sudden Decelerations	1023

PGN 65206**Trip Vehicle Speed/Cruise Distance Information****- TVI**

Transmission Repetition Rate: On request
 Data Length: 8
 Extended Data Page: 0
 Data Page: 0
 PDU Format: 254
 PDU Specific: 182 PGN Supporting Information:
 Default Priority: 7
 Parameter Group Number: 65206 (0xFEB6)

Start Position	Length	Parameter Name	SPN
1-2	2 bytes	Trip Maximum Vehicle Speed	1018
3-6	4 bytes	Trip Cruise Distance	1019

PGN 65207**Engine Speed/Load Factor Information****- LF**

Transmission Repetition Rate: On request
 Data Length: 10
 Extended Data Page: 0
 Data Page: 0
 PDU Format: 254
 PDU Specific: 183 PGN Supporting Information:
 Default Priority: 7
 Parameter Group Number: 65207 (0xFEB7)

Start Position	Length	Parameter Name	SPN
1-2	2 bytes	Trip Maximum Engine Speed	1013
3-4	2 bytes	Trip Average Engine Speed	1014
5	1 byte	Trip Drive Average Load Factor	1015
6	1 byte	Total Drive Average Load Factor	1016
7-10	4 bytes	Total Engine Cruise Time	1017

PGN 65208**Trip Fuel Information (Gaseous)****- GTFI**

Transmission Repetition Rate: On request
 Data Length: 22
 Extended Data Page: 0
 Data Page: 0
 PDU Format: 254
 PDU Specific: 184 PGN Supporting Information:
 Default Priority: 7
 Parameter Group Number: 65208 (0xFEB8)

Start Position	Length	Parameter Name	SPN
01-04	4 bytes	Trip Drive Fuel Used (Gaseous)	1007
05-08	4 bytes	Trip PTO Governor Moving Fuel Used (Gaseous)	1008
09-12	4 bytes	Trip PTO Governor Non-moving Fuel Used (Gaseous)	1009
13-16	4 bytes	Trip Vehicle Idle Fuel Used (Gaseous)	1010
17-20	4 bytes	Trip Cruise Fuel Used (Gaseous)	1011
21-22	2 bytes	Trip Drive Fuel Economy (Gaseous)	1012

PGN 65209**Trip Fuel Information (Liquid)****- LTFI**

Transmission Repetition Rate: On request
 Data Length: 22
 Extended Data Page: 0
 Data Page: 0
 PDU Format: 254
 PDU Specific: 185 PGN Supporting Information:
 Default Priority: 7
 Parameter Group Number: 65209 (0xFEB9)

Start Position	Length	Parameter Name	SPN
01-04	4 bytes	Trip Drive Fuel Used	1001
05-08	4 bytes	Trip PTO Governor Moving Fuel Used	1002
09-12	4 bytes	Trip PTO Governor Non-moving Fuel Used	1003
13-16	4 bytes	Trip Vehicle Idle Fuel Used	1004
17-20	4 bytes	Trip Cruise Fuel Used	1005
21-22	2 bytes	Trip Drive Fuel Economy	1006

PGN 65210**Trip Distance Information****- TDI**

Transmission Repetition Rate: On request
 Data Length: 12
 Extended Data Page: 0
 Data Page: 0
 PDU Format: 254
 PDU Specific: 186 PGN Supporting Information:
 Default Priority: 7
 Parameter Group Number: 65210 (0xFEBA)

Start Position	Length	Parameter Name	SPN
1-4	4 bytes	Trip Distance on VSL	998
5-8	4 bytes	Trip Gear Down Distance	999
9-12	4 bytes	Trip Distance in Top Gear	1000

PGN 65211**Trip Fan Information****- TFI**

Transmission Repetition Rate: On request
 Data Length: 16
 Extended Data Page: 0
 Data Page: 0
 PDU Format: 254
 PDU Specific: 187 PGN Supporting Information:
 Default Priority: 7
 Parameter Group Number: 65211 (0xFEBC)

Start Position	Length	Parameter Name	SPN
01-04	4 bytes	Trip Fan On Time	994
05-08	4 bytes	Trip Fan On Time Due to the Engine System	995
09-12	4 bytes	Trip Fan On Time Due to a Manual Switch	996
13-16	4 bytes	Trip Fan On Time Due to the A/C System	997

PGN 65212**Compression/Service Brake Information****- CBI**

Transmission Repetition Rate: On request
 Data Length: 16
 Extended Data Page: 0
 Data Page: 0
 PDU Format: 254
 PDU Specific: 188 PGN Supporting Information:
 Default Priority: 7
 Parameter Group Number: 65212 (0xFEBC)

Start Position	Length	Parameter Name	SPN
01-04	4 bytes	Total Compression Brake Distance	990
05-08	4 bytes	Trip Compression Brake Distance	991
09-12	4 bytes	Trip Service Brake Distance	992
13-16	4 bytes	Trip Service Brake Applications	993

PGN 65213 (R) Fan Drive**- FD**

Transmission Repetition Rate: 1 s
 Data Length: 8
 Extended Data Page: 0
 Data Page: 0
 PDU Format: 254
 PDU Specific: 189 PGN Supporting Information:
 Default Priority: 6
 Parameter Group Number: 65213 (0xFEED)

Start Position	Length	Parameter Name	SPN
1	1 byte	Estimated Percent Fan Speed	975
2.1	4 bits	Fan Drive State	977
3-4	2 bytes	Fan Speed	1639
5-6	2 bytes	Hydraulic Fan Motor Pressure	4211
7	1 byte	Fan Drive Bypass Command Status	4212

PGN 65214 Electronic Engine Controller 4**- EEC4**

Transmission Repetition Rate: On request
 Data Length: 8
 Extended Data Page: 0
 Data Page: 0
 PDU Format: 254
 PDU Specific: 190 PGN Supporting Information:
 Default Priority: 7
 Parameter Group Number: 65214 (0xFEDE)

Start Position	Length	Parameter Name	SPN
1-2	2 bytes	Engine Rated Power	166
3-4	2 bytes	Engine Rated Speed	189
5.1	2 bits	Engine Rotation Direction	3669
6	1 byte	Crank Attempt Count on Present Start Attempt	3671

PGN 65215**Wheel Speed Information****- EBC2**

Transmission Repetition Rate: 100 ms
 Data Length: 8
 Extended Data Page: 0
 Data Page: 0
 PDU Format: 254
 PDU Specific: 191 PGN Supporting Information:
 Default Priority: 6
 Parameter Group Number: 65215 (0xFEBF)

Start Position	Length	Parameter Name	SPN
1-2	2 bytes	Front Axle Speed	904
3	1 byte	Relative Speed; Front Axle, Left Wheel	905
4	1 byte	Relative Speed; Front Axle, Right Wheel	906
5	1 byte	Relative Speed; Rear Axle #1, Left Wheel	907
6	1 byte	Relative Speed; Rear Axle #1, Right Wheel	908
7	1 byte	Relative Speed; Rear Axle #2, Left Wheel	909
8	1 byte	Relative Speed; Rear Axle #2, Right Wheel	910

PGN 65216**Service Information****- SERV**

Transmitted with the service component identification that has the shortest distance or nearest time until the next service inspection.

NOTE - There are two acceptable formats for the Service PGN. Format 1 has only 8 bytes of data and reports the component most in need of service for each of the three categories. Format 2, however, uses the transport layer as necessary in order to repeat these 8 bytes of service component information until all supported service components in each category have been transmitted.

Transmission Repetition Rate: On request
 Data Length: 8 bytes or variable
 Extended Data Page: 0
 Data Page: 0
 PDU Format: 254
 PDU Specific: 192 PGN Supporting Information:
 Default Priority: 6
 Parameter Group Number: 65216 (0xFEC0)

Start Position	Length	Parameter Name	SPN
1	1 byte	Service Component Identification	911
2-3	2 bytes	Service Distance	914
4	1 byte	Service Component Identification	912
5	1 byte	Service Delay/Calendar Time Based	915
6	1 byte	Service Component Identification	913
7-8	2 bytes	Service Delay/Operational Time Based	916

PGN 65217**High Resolution Vehicle Distance****- VDHR**

Transmission Repetition Rate: 1 s
 Data Length: 8
 Extended Data Page: 0
 Data Page: 0
 PDU Format: 254
 PDU Specific: 193 PGN Supporting Information:
 Default Priority: 6
 Parameter Group Number: 65217 (0xFEC1)

Start Position	Length	Parameter Name	SPN
1-4	4 bytes	High Resolution Total Vehicle Distance	917
5-8	4 bytes	High Resolution Trip Distance	918

PGN 65218**Electronic Retarder Controller 2****- ERC2**

Transmission Repetition Rate: 1 s when active; or on change of state
 Data Length: 8
 Extended Data Page: 0
 Data Page: 0
 PDU Format: 254
 PDU Specific: 194 PGN Supporting Information:
 Default Priority: 7
 Parameter Group Number: 65218 (0xFEC2)

Start Position	Length	Parameter Name	SPN
1.1	2 bits	Transmission Output Retarder	748

PGN 65219**Electronic Transmission Controller 5****- ETC5**

Transmission Repetition Rate: On request
 Data Length: 8
 Extended Data Page: 0
 Data Page: 0
 PDU Format: 254
 PDU Specific: 195 PGN Supporting Information:
 Default Priority: 7
 Parameter Group Number: 65219 (0xFEC3)

Start Position	Length	Parameter Name	SPN
1.1	2 bits	Transmission High Range Sense Switch	778
1.3	2 bits	Transmission Low Range Sense Switch	779
2.1	2 bits	Transmission Reverse Direction Switch	767
2.3	2 bits	Transmission Neutral Switch	604
2.5	2 bits	Transmission Forward Direction Switch	903

PGN 65221**Electronic Transmission Controller 4****- ETC4**

Transmission Repetition Rate: On request
 Data Length: 8
 Extended Data Page: 0
 Data Page: 0
 PDU Format: 254
 PDU Specific: 197 PGN Supporting Information:
 Default Priority: 7
 Parameter Group Number: 65221 (0xFEC5)

Start Position	Length	Parameter Name	SPN
1	1 byte	Transmission Synchronizer Clutch Value	53
2	1 byte	Transmission Synchronizer Brake Value	54

PGN 65223**Electronic Transmission Controller 3****- ETC3**

Transmission Repetition Rate: On request
 Data Length: 8
 Extended Data Page: 0
 Data Page: 0
 PDU Format: 254
 PDU Specific: 199 PGN Supporting Information:
 Default Priority: 7
 Parameter Group Number: 65223 (0xFEC7)

Start Position	Length	Parameter Name	SPN
1	1 byte	Transmission Shift Finger Gear Position	59
2	1 byte	Transmission Shift Finger Rail Position	60
3.1	2 bits	Transmission Shift Finger Neutral Indicator	780
3.3	2 bits	Transmission Shift Finger Engagement Indicator	781
3.5	2 bits	Transmission Shift Finger Center Rail Indicator	782
4.1	2 bits	Transmission Shift Finger Rail Actuator 1	772
4.3	2 bits	Transmission Shift Finger Gear Actuator 1	773
4.5	2 bits	Transmission Shift Finger Rail Actuator 2	783
4.7	2 bits	Transmission Shift Finger Gear Actuator 2	784
5.1	2 bits	Transmission Range High Actuator	768
5.3	2 bits	Transmission Range Low Actuator	769
5.5	2 bits	Transmission Splitter Direct Actuator	770
5.7	2 bits	Transmission Splitter Indirect Actuator	771
6.1	2 bits	Transmission Clutch Actuator	788
6.3	2 bits	Transmission Lockup Clutch Actuator	740
6.5	2 bits	Transmission Defuel Actuator	786
6.7	2 bits	Transmission Inertia Brake Actuator	787

PGN 65237**Alternator Information****- AS**

Transmission Repetition Rate: 1 sec
 Data Length: 8
 Extended Data Page: 0
 Data Page: 0
 PDU Format: 254
 PDU Specific: 213 PGN Supporting Information:
 Default Priority: 6
 Parameter Group Number: 65237 (0xFED5)

Start Position	Length	Parameter Name	SPN
1-2	2 bytes	Alternator Speed	589
3.1	2 bits	Alternator 1 Status	3353
3.3	2 bits	Alternator 2 Status	3354
3.5	2 bits	Alternator 3 Status	3355
3.7	2 bits	Alternator 4 Status	3356

PGN 65241**Auxiliary Input/Output Status 1****- AUXIO1**

Notes:

Implementers are encouraged to use specific functional SPNs whenever possible.

AUXIO PGNs are intended for two categories of use in which fixed mapping to functions is not possible:

- 1) Generic I/O devices
 - 2) Applications lacking defined input and output functionality.
- Use, or request new, functionally defined parameters in all other cases.

Implementers and integrators considering using AUXIO PGNs should be cautious of conflicts that can arise from multiple users on a single system.

Transmission Repetition Rate: manufacturer defined, not faster than 100 ms
 Data Length: 8
 Extended Data Page: 0
 Data Page: 0
 PDU Format: 254
 PDU Specific: 217 PGN Supporting Information:
 Default Priority: 6
 Parameter Group Number: 65241 (0xFED9)

Start Position	Length	Parameter Name	SPN
1.1	2 bits	Auxiliary I/O #04	704
1.3	2 bits	Auxiliary I/O #03	703
1.5	2 bits	Auxiliary I/O #02	702
1.7	2 bits	Auxiliary I/O #01	701
2.1	2 bits	Auxiliary I/O #08	708
2.3	2 bits	Auxiliary I/O #07	707
2.5	2 bits	Auxiliary I/O #06	706
2.7	2 bits	Auxiliary I/O #05	705
3.1	2 bits	Auxiliary I/O #12	712
3.3	2 bits	Auxiliary I/O #11	711
3.5	2 bits	Auxiliary I/O #10	710
3.7	2 bits	Auxiliary I/O #09	709
4.1	2 bits	Auxiliary I/O #16	716
4.3	2 bits	Auxiliary I/O #15	715
4.5	2 bits	Auxiliary I/O #14	714
4.7	2 bits	Auxiliary I/O #13	713
5-6	2 bytes	Auxiliary I/O Channel #1	1083
7-8	2 bytes	Auxiliary I/O Channel #2	1084

PGN 65242**Software Identification****- SOFT**

Byte: 1 Number of software identification fields

2-n Software identification(s)

Delimiter (ASCII "**")

NOTE- The software identification field is variable in length and may contain up to 125 software identification designators. An ASCII "**" is used as a delimiter to separate multiple software identifications. Additional software identification fields may be added at the end, each separated by an ASCII "**" as a delimiter. An ASCII "**" is required at the end of the last software identification field, even if there is only one software identification designator.

Transmission Repetition Rate: On request

Data Length: Variable

Extended Data Page: 0

Data Page: 0

PDU Format: 254

PDU Specific: 218 PGN Supporting Information:

Default Priority: 6

Parameter Group Number: 65242 (0xFEDA)

Start Position	Length	Parameter Name	SPN
1	1 byte	Number of Software Identification Fields	965
2-N	Variable - up to 200 characters (** delimited)	Software Identification	234

PGN 65243**Engine Fluid Level/Pressure 2****- EFL/P2**

Transmission Repetition Rate: 0.5 s
 Data Length: 8
 Extended Data Page: 0
 Data Page: 0
 PDU Format: 254
 PDU Specific: 219 PGN Supporting Information:
 Default Priority: 6
 Parameter Group Number: 65243 (0xFEDB)

Start Position	Length	Parameter Name	SPN
1-2	2 bytes	Engine Injection Control Pressure	164
3-4	2 bytes	Engine Injector Metering Rail 1 Pressure	157
5-6	2 bytes	Engine Injector Timing Rail 1 Pressure	156
7-8	2 bytes	Engine Injector Metering Rail 2 Pressure	1349

PGN 65244**Idle Operation****- IO**

Transmission Repetition Rate: On request
 Data Length: Variable
 Extended Data Page: 0
 Data Page: 0
 PDU Format: 254
 PDU Specific: 220 PGN Supporting Information:
 Default Priority: 6
 Parameter Group Number: 65244 (0xFEDC)

Start Position	Length	Parameter Name	SPN
1-4	4 bytes	Engine Total Idle Fuel Used	236
5-8	4 bytes	Engine Total Idle Hours	235

PGN 65245**Turbocharger****- TC**

Transmission Repetition Rate: 1 s
 Data Length: 8
 Extended Data Page: 0
 Data Page: 0
 PDU Format: 254
 PDU Specific: 221 PGN Supporting Information:
 Default Priority: 6
 Parameter Group Number: 65245 (0xFEDD)

Start Position	Length	Parameter Name	SPN
1	1 byte	Engine Turbocharger Lube Oil Pressure 1	104
2-3	2 bytes	Engine Turbocharger 1 Speed	103
4.7	2 bits	Engine Turbocharger Oil Level Switch	1665

PGN 65246**Air Start Pressure****- AIR2**

Transmission Repetition Rate: On request
 Data Length: 8
 Extended Data Page: 0
 Data Page: 0
 PDU Format: 254
 PDU Specific: 222 PGN Supporting Information:
 Default Priority: 6
 Parameter Group Number: 65246 (0xFEDE)

Start Position	Length	Parameter Name	SPN
1	1 byte	Engine Air Start Pressure	82

PGN 65247**Electronic Engine Controller 3****- EEC3**

Transmission Repetition Rate: 250 msec
 Data Length: 8
 Extended Data Page: 0
 Data Page: 0
 PDU Format: 254
 PDU Specific: 223 PGN Supporting Information:
 Default Priority: 6
 Parameter Group Number: 65247 (0xFEDF)

Start Position	Length	Parameter Name	SPN
1	1 byte	Nominal Friction - Percent Torque	514
2-3	2 bytes	Engine's Desired Operating Speed	515
4	1 byte	Engine's Desired Operating Speed Asymmetry Adjustment	519
5	1 byte	Estimated Engine Parasitic Losses - Percent Torque	2978
6-7	2 bytes	Aftertreatment 1 Exhaust Gas Mass Flow	3236
8.1	2 bits	Aftertreatment 1 Intake Dew Point	3237
8.3	2 bits	Aftertreatment 1 Exhaust Dew Point	3238
8.5	2 bits	Aftertreatment 2 Intake Dew Point	3239
8.7	2 bits	Aftertreatment 2 Exhaust Dew Point	3240

PGN 65248**Vehicle Distance****- VD**

Transmission Repetition Rate: 100 ms
 Data Length: 8
 Extended Data Page: 0
 Data Page: 0
 PDU Format: 254
 PDU Specific: 224 PGN Supporting Information:
 Default Priority: 6
 Parameter Group Number: 65248 (0xFEE0)

Start Position	Length	Parameter Name	SPN
1-4	4 bytes	Trip Distance	244
5-8	4 bytes	Total Vehicle Distance	245

PGN 65249**Retarder Configuration****- RC**

This map describes the stationary behavior of the retarder.

Transmission Repetition Rate: On change of torque/speed points of more than 10% since last transmission, or every 5 s.
 Data Length: 19
 Extended Data Page: 0
 Data Page: 0
 PDU Format: 254
 PDU Specific: 225 PGN Supporting Information: See Appendix D - PGN 65249
 Default Priority: 6
 Parameter Group Number: 65249 (0xFEE1)

Start Position	Length	Parameter Name	SPN
01.1	4 bits	Retarder Type	901
01.5	4 bits	Retarder Location	902
02	1 byte	Retarder Control Method (Retarder Configuration)	557
03-04	2 bytes	Retarder Speed At Idle, Point 1 (Retarder Configuration)	546
05	1 byte	Percent Torque At Idle, Point 1 (Retarder Configuration)	551
06-07	2 bytes	Maximum Retarder Speed, Point 2 (Retarder Configuration)	548
08	1 byte	Percent Torque At Maximum Speed, Point 2 (Retarder Configuration)	552
09-10	2 bytes	Retarder Speed At Point 3 (Retarder Configuration)	549
11	1 byte	Percent Torque At Point 3 (Retarder Configuration)	553
12-13	2 bytes	Retarder Speed At Point 4 (Retarder Configuration)	550
14	1 byte	Percent Torque At Point 4 (Retarder Configuration)	554
15-16	2 bytes	Retarder Speed At Peak Torque, Point 5 (Retarder Configuration)	547
17-18	2 bytes	Reference Retarder Torque (Retarder Configuration)	556
19	1 byte	Percent Torque At Peak Torque, Point 5 (Retarder Configuration)	555

PGN 65250**Transmission Configuration****- TCFG**

Total message length depends on total number of forward and reverse gear ratios.

NOTE: The first gear ratio transmitted in bytes 3,4 will be the highest reverse gear ratio. Additional 2-byte gear ratios will follow:

- 3,4 Highest reverse gear ratio
- .
- .
- a,b Lowest reverse gear ratio
- c,d Lowest forward gear ratio
- .
- .
- e,f Highest forward gear ratio

Transmission Repetition Rate: On request
 Data Length: Variable
 Extended Data Page: 0
 Data Page: 0
 PDU Format: 254
 PDU Specific: 226 PGN Supporting Information:
 Default Priority: 6
 Parameter Group Number: 65250 (0xFEE2)

Start Position	Length	Parameter Name	SPN
1	1 byte	Number of Reverse Gear Ratios	958
2	1 byte	Number of Forward Gear Ratios	957
3-4	2 bytes	Transmission Gear Ratio	581

PGN 65251**Engine Configuration 1****- EC1**

This map describes the stationary behavior of the engine and the speed dependent available indicated torque. This map should reflect the effect of changes due to barometric pressure, engine temperature, and any other stationary changes (sensor failures, etc.) which influence the engine torque curve more than 10%. This map is only valid for maximum boost pressure. At low boost pressures the torque limit may be much lower.

The engine configuration message must be sent at any time that the engine configuration map has changed by more than 10% of speed or torque (due to events other than boost pressure) since that last time the message was transmitted. As an alternative, it may be sent periodically, once every 5 s. It shall also be sent on response to a configuration request message.

The engine characteristic can be described in one of three modes. Mode 1 provides a complete curve of speed and torque points (see PGN65251_A). Modes 2 and 3 provide a partial curve of speed and torque points and a separate endspeed governor characteristic. In modes 2 and 3, the receiver of the engine configuration message has to calculate the minimum of the engine torque curve and the endspeed governor characteristic to get the final available engine torque.

Mode 2 provides a high idle point where torque equals zero (point 6) and the endspeed governor gain Kp (see Figure PGN65251_B). Mode 3 provides the kick-in point of the endspeed governor (point 2) and the governor gain Kp (see Figure PGN65251_C).

The selection of the three modes can be done by setting the parameters as shown in 'Table PGN65251_A.

Transmission Repetition Rate: On change of torque/speed points of more than 10% since last transmission.
Alternative: Every 5 s.

Data Length: 39

Extended Data Page: 0

Data Page: 0

PDU Format: 254

PDU Specific: 227 PGN Supporting Information: See Appendix D - PGN 65251

Default Priority: 6

Parameter Group Number: 65251 (0xFEE3)

Start Position	Length	Parameter Name	SPN
01-02	2 bytes	Engine Speed At Idle, Point 1 (Engine Configuration)	188
03	1 byte	Engine Percent Torque At Idle, Point 1 (Engine Configuration)	539
04-05	2 bytes	Engine Speed At Point 2 (Engine Configuration)	528
06	1 byte	Engine Percent Torque At Point 2 (Engine Configuration)	540
07-08	2 bytes	Engine Speed At Point 3 (Engine Configuration)	529
09	1 byte	Engine Percent Torque At Point 3 (Engine Configuration)	541
10-11	2 bytes	Engine Speed At Point 4 (Engine Configuration)	530
12	1 byte	Engine Percent Torque At Point 4 (Engine Configuration)	542
13-14	2 bytes	Engine Speed At Point 5 (Engine Configuration)	531
15	1 byte	Engine Percent Torque At Point 5 (Engine Configuration)	543
16-17	2 bytes	Engine Speed At High Idle, Point 6 (Engine Configuration)	532
18-19	2 bytes	Engine Gain (Kp) Of The Endspped Governor (Engine Configuration)	545
20-21	2 bytes	Engine Reference Torque (Engine Configuration)	544
22-23	2 bytes	Engine Maximum Momentary Override Speed, Point 7 (Engine Configuration)	533
24	1 byte	Engine Maximum Momentary Override Time Limit (Engine Configuration)	534
25	1 byte	Engine Requested Speed Control Range Lower Limit (Engine Configuration)	535
26	1 byte	Engine Requested Speed Control Range Upper Limit (Engine Configuration)	536
27	1 byte	Engine Requested Torque Control Range Lower Limit (Engine Configuration)	537
28	1 byte	Engine Requested Torque Control Range Upper Limit (Engine Configuration)	538
29-30	2 bytes	Engine Extended Range Requested Speed Control Range Upper Limit (Engine configuration)	1712
31-32	2 bytes	Engine Moment of Inertia	1794
33-34	2 bytes	Engine Default Torque Limit	1846
35	8 bits	Support Variable Rate TSC1 Message	3344
36	8 bits	Support TSC1 Control Purpose Group 1	3345
37	8 bits	Support TSC1 Control Purpose Group 2	3346
38	8 bits	Support TSC1 Control Purpose Group 3	3347
39	8 bits	Support TSC1 Control Purpose Group 4	3348

PGN 65252**Shutdown****- SHUTDN**

Transmission Repetition Rate: 1 s
 Data Length: 8
 Extended Data Page: 0
 Data Page: 0
 PDU Format: 254
 PDU Specific: 228 PGN Supporting Information:
 Default Priority: 6
 Parameter Group Number: 65252 (0xFEE4)

Start Position	Length	Parameter Name	SPN
1.1	2 bits	Engine Idle Shutdown has Shutdown Engine	593
1.3	2 bits	Engine Idle Shutdown Driver Alert Mode	594
1.5	2 bits	Engine Idle Shutdown Timer Override	592
1.7	2 bits	Engine Idle Shutdown Timer State	590
2.7	2 bits	Engine Idle Shutdown Timer Function	591
3.1	2 bits	A/C High Pressure Fan Switch	985
3.3	2 bits	Refrigerant Low Pressure Switch	875
3.5	2 bits	Refrigerant High Pressure Switch	605
4.1	2 bits	Engine Wait to Start Lamp	1081
5.1	2 bits	Engine Protection System has Shutdown Engine	1110
5.3	2 bits	Engine Protection System Approaching Shutdown	1109
5.5	2 bits	Engine Protection System Timer Override	1108
5.7	2 bits	Engine Protection System Timer State	1107
6.7	2 bits	Engine Protection System Configuration	1111
7.1	2 bits	Engine Alarm Acknowledge	2815
7.3	2 bits	Engine Alarm Output Command Status	2814
7.5	2 bits	Engine Air Shutoff Command Status	2813
7.7	2 bits	Engine Overspeed Test	2812
8.1	2 bits	Engine Air Shutoff Status	3667

PGN 65253**Engine Hours, Revolutions****- HOURS**

Transmission Repetition Rate: On request

Data Length: 8

Extended Data Page: 0

Data Page: 0

PDU Format: 254

PDU Specific: 229 PGN Supporting Information:

Default Priority: 6

Parameter Group Number: 65253 (0xFEE5)

Start Position	Length	Parameter Name	SPN
1-4	4 bytes	Engine Total Hours of Operation	247
5-8	4 bytes	Engine Total Revolutions	249

PGN 65254**Time/Date****- TD**

Transmission Repetition Rate: On request

Data Length: 8

Extended Data Page: 0

Data Page: 0

PDU Format: 254

PDU Specific: 230 PGN Supporting Information:

Default Priority: 6

Parameter Group Number: 65254 (0xFEE6)

Start Position	Length	Parameter Name	SPN
1	1 byte	Seconds	959
2	1 byte	Minutes	960
3	1 byte	Hours	961
4	1 byte	Month	963
5	1 byte	Day	962
6	1 byte	Year	964
7	1 byte	Local minute offset	1601
8	1 byte	Local hour offset	1602

PGN 65255**Vehicle Hours****- VH**

Transmission Repetition Rate: On request
 Data Length: 8
 Extended Data Page: 0
 Data Page: 0
 PDU Format: 254
 PDU Specific: 231 PGN Supporting Information:
 Default Priority: 6
 Parameter Group Number: 65255 (0xFEE7)

Start Position	Length	Parameter Name	SPN
1-4	4 bytes	Total Vehicle Hours	246
5-8	4 bytes	Total Power Takeoff Hours	248

PGN 65256**Vehicle Direction/Speed****- VDS**

Transmission Repetition Rate: On request
 Data Length: 8
 Extended Data Page: 0
 Data Page: 0
 PDU Format: 254
 PDU Specific: 232 PGN Supporting Information:
 Default Priority: 6
 Parameter Group Number: 65256 (0xFEE8)

Start Position	Length	Parameter Name	SPN
1-2	2 bytes	Compass Bearing	165
3-4	2 bytes	Navigation-Based Vehicle Speed	517
5-6	2 bytes	Pitch	583
7-8	2 bytes	Altitude	580

PGN 65257**Fuel Consumption (Liquid)****- LFC**

Transmission Repetition Rate: On request
 Data Length: 8
 Extended Data Page: 0
 Data Page: 0
 PDU Format: 254
 PDU Specific: 233 PGN Supporting Information:
 Default Priority: 6
 Parameter Group Number: 65257 (0xFEE9)

Start Position	Length	Parameter Name	SPN
1-4	4 bytes	Engine Trip Fuel	182
5-8	4 bytes	Engine Total Fuel Used	250

PGN 65258**Vehicle Weight****- VW**

NOTE—Request has to be responded to with as many messages as necessary to transmit all available information.

Transmission Repetition Rate: On request
 Data Length: 8
 Extended Data Page: 0
 Data Page: 0
 PDU Format: 254
 PDU Specific: 234 PGN Supporting Information:
 Default Priority: 6
 Parameter Group Number: 65258 (0xFEEA)

Start Position	Length	Parameter Name	SPN
1	8 bits	Axle Location	928
2-3	2 bytes	Axle Weight	582
4-5	2 bytes	Trailer Weight	180
6-7	2 bytes	Cargo Weight	181

PGN 65259**Component Identification****- CI**

NOTE - The make, model, serial number and unit number fields in this message are optional and separated by an ASCII "**". It is not necessary to include all fields; however, the delimiter ("**") is always required.

Field:

a Make

Delimiter (ASCII "**")

b Model

Delimiter (ASCII "**")

c Serial number

Delimiter (ASCII "**")

d Unit number (Power unit)

Delimiter (ASCII "**")

These examples are permitted uses:

aaaaa*b...b*c...c*d...d*

*b...b***

*b...b**d...d*

Transmission Repetition Rate: On request
 Data Length: Variable
 Extended Data Page: 0
 Data Page: 0
 PDU Format: 254
 PDU Specific: 235 PGN Supporting Information:
 Default Priority: 6
 Parameter Group Number: 65259 (0xFEED)

Start Position	Length	Parameter Name	SPN
a	Variable - up to 5 characters (** delimited)	Make	586
b	Variable - up to 200 characters (** delimited)	Model	587
c	Variable - up to 200 characters (** delimited)	Serial Number	588
d	Variable - up to 200 characters (** delimited)	Unit Number (Power Unit)	233

PGN 65260**Vehicle Identification****- VI**

Byte: 1-n Vehicle Identification Number
 Delimiter (ASCII "**")

Transmission Repetition Rate: On request
 Data Length: Variable
 Extended Data Page: 0
 Data Page: 0
 PDU Format: 254
 PDU Specific: 236 PGN Supporting Information:
 Default Priority: 6
 Parameter Group Number: 65260 (0xFEED)

Start Position	Length	Parameter Name	SPN
1	Variable - up to 200 characters ("**" delimited)	Vehicle Identification Number	237

PGN 65261**Cruise Control/Vehicle Speed Setup****- CCSS**

Transmission Repetition Rate: On request
 Data Length: 8
 Extended Data Page: 0
 Data Page: 0
 PDU Format: 254
 PDU Specific: 237 PGN Supporting Information:
 Default Priority: 6
 Parameter Group Number: 65261 (0xFEED)

Start Position	Length	Parameter Name	SPN
1	1 byte	Maximum Vehicle Speed Limit	74
2	1 byte	Cruise Control High Set Limit Speed	87
3	1 byte	Cruise Control Low Set Limit Speed	88

PGN 65262**Engine Temperature 1****- ET1**

Transmission Repetition Rate: 1 s
 Data Length: 8
 Extended Data Page: 0
 Data Page: 0
 PDU Format: 254
 PDU Specific: 238 PGN Supporting Information:
 Default Priority: 6
 Parameter Group Number: 65262 (0xFEEE)

Start Position	Length	Parameter Name	SPN
1	1 byte	Engine Coolant Temperature	110
2	1 byte	Engine Fuel Temperature 1	174
3-4	2 bytes	Engine Oil Temperature 1	175
5-6	2 bytes	Engine Turbocharger Oil Temperature	176
7	1 byte	Engine Intercooler Temperature	52
8	1 byte	Engine Intercooler Thermostat Opening	1134

PGN 65263**Engine Fluid Level/Pressure 1****- EFL/P1**

Transmission Repetition Rate: 0.5 s
 Data Length: 8
 Extended Data Page: 0
 Data Page: 0
 PDU Format: 254
 PDU Specific: 239 PGN Supporting Information:
 Default Priority: 6
 Parameter Group Number: 65263 (0xFEEF)

Start Position	Length	Parameter Name	SPN
1	1 byte	Engine Fuel Delivery Pressure	94
2	1 byte	Engine Extended Crankcase Blow-by Pressure	22
3	1 byte	Engine Oil Level	98
4	1 byte	Engine Oil Pressure	100
5-6	2 bytes	Engine Crankcase Pressure	101
7	1 byte	Engine Coolant Pressure	109
8	1 byte	Engine Coolant Level	111

PGN 65264**Power Takeoff Information****- PTO**

Transmission Repetition Rate: 100 ms
 Data Length: 8
 Extended Data Page: 0
 Data Page: 0
 PDU Format: 254
 PDU Specific: 240 PGN Supporting Information:
 Default Priority: 6
 Parameter Group Number: 65264 (0xFEFO)

Start Position	Length	Parameter Name	SPN
1	1 byte	Power Takeoff Oil Temperature	90
2-3	2 bytes	Power Takeoff Speed	186
4-5	2 bytes	Power Takeoff Set Speed	187
6.1	2 bits	Engine PTO Governor Enable Switch	980
6.3	2 bits	Engine Remote PTO Governor Preprogrammed Speed Control Switch	979
6.5	2 bits	Engine Remote PTO Governor Variable Speed Control Switch	978
7.1	2 bits	Engine PTO Governor Set Switch	984
7.3	2 bits	Engine PTO Governor Coast/Decelerate Switch	983
7.5	2 bits	Engine PTO Governor Resume Switch	982
7.7	2 bits	Engine PTO Governor Accelerate Switch	981
8.1	2 bits	Operator Engine PTO Governor Memory Select Switch	2897
8.3	2 bits	Remote PTO Governor Preprogrammed Speed Control Switch #2	3447
8.5	2 bits	Auxiliary Input Ignore Switch	3448

PGN 65265**Cruise Control/Vehicle Speed****- CCVS**

Transmission Repetition Rate: 100 ms
 Data Length: 8
 Extended Data Page: 0
 Data Page: 0
 PDU Format: 254
 PDU Specific: 241 PGN Supporting Information:
 Default Priority: 6
 Parameter Group Number: 65265 (0xFEf1)

Start Position	Length	Parameter Name	SPN
1.1	2 bits	Two Speed Axle Switch	69
1.3	2 bits	Parking Brake Switch	70
1.5	2 bits	Cruise Control Pause Switch	1633
1.7	2 bits	Park Brake Release Inhibit Request	3807
2-3	2 bytes	Wheel-Based Vehicle Speed	84
4.1	2 bits	Cruise Control Active	595
4.3	2 bits	Cruise Control Enable Switch	596
4.5	2 bits	Brake Switch	597
4.7	2 bits	Clutch Switch	598
5.1	2 bits	Cruise Control Set Switch	599
5.3	2 bits	Cruise Control Coast (Decelerate) Switch	600
5.5	2 bits	Cruise Control Resume Switch	601
5.7	2 bits	Cruise Control Accelerate Switch	602
6	1 byte	Cruise Control Set Speed	86
7.1	5 bits	PTO Governor State	976
7.6	3 bits	Cruise Control States	527
8.1	2 bits	Engine Idle Increment Switch	968
8.3	2 bits	Engine Idle Decrement Switch	967
8.5	2 bits	Engine Test Mode Switch	966
8.7	2 bits	Engine Shutdown Override Switch	1237

PGN 65266**Fuel Economy (Liquid)****- LFE**

Transmission Repetition Rate: 100 ms
 Data Length: 8
 Extended Data Page: 0
 Data Page: 0
 PDU Format: 254
 PDU Specific: 242 PGN Supporting Information:
 Default Priority: 6
 Parameter Group Number: 65266 (0xFEf2)

Start Position	Length	Parameter Name	SPN
1-2	2 bytes	Engine Fuel Rate	183
3-4	2 bytes	Engine Instantaneous Fuel Economy	184
5-6	2 bytes	Engine Average Fuel Economy	185
7	1 byte	Engine Throttle Position	51
8	1 byte	Engine Throttle 2 Position	3673

PGN 65267**Vehicle Position****- VP**

Transmission Repetition Rate: 5 s
 Data Length: 8
 Extended Data Page: 0
 Data Page: 0
 PDU Format: 254
 PDU Specific: 243 PGN Supporting Information:
 Default Priority: 6
 Parameter Group Number: 65267 (0xFEf3)

Start Position	Length	Parameter Name	SPN
1-4	4 bytes	Latitude	584
5-8	4 bytes	Longitude	585

PGN 65268**Tire Condition****- TIRE**

Tire Condition Message

NOTE—Message has to be repeated as necessary to transmit all available information. This method of location identification requires individual SPNs to be assigned to report failures specific to each individual component (i.e. each tire, each axle, etc.).

Transmission Repetition Rate: 10 s
 Data Length: 8
 Extended Data Page: 0
 Data Page: 0
 PDU Format: 254
 PDU Specific: 244 PGN Supporting Information:
 Default Priority: 6
 Parameter Group Number: 65268 (0xFEf4)

Start Position	Length	Parameter Name	SPN
1	8 bits	Tire Location	929
2	1 byte	Tire Pressure	241
3-4	2 bytes	Tire Temperature	242
5.1	2 bits	CTI Wheel Sensor Status	1699
5.3	2 bits	CTI Tire Status	1698
5.5	2 bits	CTI Wheel End Electrical Fault	1697
6-7	2 bytes	Tire Air Leakage Rate	2586
8.6	3 bits	Tire Pressure Threshold Detection	2587

PGN 65269**Ambient Conditions****- AMB**

Transmission Repetition Rate: 1 s
 Data Length: 8
 Extended Data Page: 0
 Data Page: 0
 PDU Format: 254
 PDU Specific: 245 PGN Supporting Information:
 Default Priority: 6
 Parameter Group Number: 65269 (0xFE5)

Start Position	Length	Parameter Name	SPN
1	1 byte	Barometric Pressure	108
2-3	2 bytes	Cab Interior Temperature	170
4-5	2 bytes	Ambient Air Temperature	171
6	1 byte	Engine Air Inlet Temperature	172
7-8	2 bytes	Road Surface Temperature	79

PGN 65270**Inlet/Exhaust Conditions 1****- IC1**

Transmission Repetition Rate: 0.5 s
 Data Length: 8
 Extended Data Page: 0
 Data Page: 0
 PDU Format: 254
 PDU Specific: 246 PGN Supporting Information:
 Default Priority: 6
 Parameter Group Number: 65270 (0xFE6)

Start Position	Length	Parameter Name	SPN
1	1 byte	Engine Diesel Particulate Filter Inlet Pressure	81
2	1 byte	Engine Intake Manifold #1 Pressure	102
3	1 byte	Engine Intake Manifold 1 Temperature	105
4	1 byte	Engine Air Inlet Pressure	106
5	1 byte	Engine Air Filter 1 Differential Pressure	107
6-7	2 bytes	Engine Exhaust Gas Temperature	173
8	1 byte	Engine Coolant Filter Differential Pressure	112

PGN 65271**Vehicle Electrical Power 1****- VEP1**

Transmission Repetition Rate: 1 s
 Data Length: 8
 Extended Data Page: 0
 Data Page: 0
 PDU Format: 254
 PDU Specific: 247 PGN Supporting Information: See Appendix D - PGN 65104
 Default Priority: 6
 Parameter Group Number: 65271 (0xFE7)

Start Position	Length	Parameter Name	SPN
1	1 byte	Net Battery Current	114
2	1 byte	Alternator Current	115
3-4	2 bytes	Charging System Potential (Voltage)	167
5-6	2 bytes	Battery Potential / Power Input 1	168
7-8	2 bytes	Keyswitch Battery Potential	158

PGN 65272**Transmission Fluids 1****- TRF1**

Transmission Repetition Rate: 1 s
 Data Length: 8
 Extended Data Page: 0
 Data Page: 0
 PDU Format: 254
 PDU Specific: 248 PGN Supporting Information:
 Default Priority: 6
 Parameter Group Number: 65272 (0xFE8)

Start Position	Length	Parameter Name	SPN
1	1 byte	Clutch Pressure	123
2	1 byte	Transmission Oil Level	124
3	1 byte	Transmission Filter Differential Pressure	126
4	1 byte	Transmission Oil Pressure	127
5-6	2 bytes	Transmission Oil Temperature	177
7	1 bytes	Transmission Oil Level High / Low	3027
8.1	4 bits	Transmission Oil Level Countdown Timer	3028
8.5	4 bits	Transmission Oil Level Measurement Status	3026

PGN 65273**Axle Information****- AI**

Axle information message

NOTE—Message must be repeated as necessary to transmit all available information. This method of location identification requires individual SPNs to be assigned to report failures specific to each individual component (I.e. each tire, each axle, etc.).

Transmission Repetition Rate: 1 s
 Data Length: 8
 Extended Data Page: 0
 Data Page: 0
 PDU Format: 254
 PDU Specific: 249 PGN Supporting Information:
 Default Priority: 6
 Parameter Group Number: 65273 (0xFE9)

Start Position	Length	Parameter Name	SPN
1	1 byte	Steering Axle Temperature	75
2	8 bits	Drive Axle Location	930
3	1 byte	Drive Axle Lift Air Pressure	579
4	1 byte	Drive Axle Temperature	578
5	1 byte	Drive Axle Lube Pressure	2613
8	1 byte	Steering Axle Lube Pressure	2614

PGN 65274**Brakes****- B**

Transmission Repetition Rate: 1 s
 Data Length: 8
 Extended Data Page: 0
 Data Page: 0
 PDU Format: 254
 PDU Specific: 250 PGN Supporting Information:
 Default Priority: 6
 Parameter Group Number: 65274 (0xFEFA)

Start Position	Length	Parameter Name	SPN
1	1 byte	Brake Application Pressure	116
2	1 byte	Brake Primary Pressure	117
3	1 byte	Brake Secondary Pressure	118
4.1	2 bits	Parking Brake Actuator	619
4.3	2 bits	Parking Brake Red Warning Signal	3557
4.5	2 bits	Park Brake Release Inhibit Status	3808

PGN 65275**Retarder fluids****- RF**

Transmission Repetition Rate: 1 s
 Data Length: 8
 Extended Data Page: 0
 Data Page: 0
 PDU Format: 254
 PDU Specific: 251 PGN Supporting Information:
 Default Priority: 6
 Parameter Group Number: 65275 (0xFEFB)

Start Position	Length	Parameter Name	SPN
1	1 byte	Hydraulic Retarder Pressure	119
2	1 byte	Hydraulic Retarder Oil Temperature	120

PGN 65276**(R) Dash Display****- DD**

Transmission Repetition Rate: 1s
 Data Length: 8
 Extended Data Page: 0
 Data Page: 0
 PDU Format: 254
 PDU Specific: 252 PGN Supporting Information:
 Default Priority: 6
 Parameter Group Number: 65276 (0xFEFC)

Start Position	Length	Parameter Name	SPN
1	1 byte	Washer Fluid Level	80
2	1 byte	Fuel Level 1	96
3	1 byte	Engine Fuel Filter Differential Pressure	95
4	1 byte	Engine Oil Filter Differential Pressure	99
5-6	2 bytes	Cargo Ambient Temperature	169
7	1 byte	Fuel Level 2	38

PGN 65277**Alternate Fuel 1****- A1**

Transmission Repetition Rate: 500 ms
 Data Length: 8
 Extended Data Page: 0
 Data Page: 0
 PDU Format: 254
 PDU Specific: 253 PGN Supporting Information:
 Default Priority: 6
 Parameter Group Number: 65277 (0xFEFD)

Start Position	Length	Parameter Name	SPN
1	1 byte	Engine Blower Bypass Valve Position	72
2-3	2 bytes	Engine Gas Supply Pressure	159

PGN 65278**Auxiliary Water Pump Pressure****- AWPP**

Transmission Repetition Rate: 1 s
 Data Length: 8
 Extended Data Page: 0
 Data Page: 0
 PDU Format: 254
 PDU Specific: 254 PGN Supporting Information:
 Default Priority: 6
 Parameter Group Number: 65278 (0xFEFE)

Start Position	Length	Parameter Name	SPN
1	1 byte	Auxiliary Pump Pressure	73

PGN 65279**Water in Fuel Indicator****- WFI**

Transmission Repetition Rate: 10 s
 Data Length: 8
 Extended Data Page: 0
 Data Page: 0
 PDU Format: 254
 PDU Specific: 255 PGN Supporting Information:
 Default Priority: 6
 Parameter Group Number: 65279 (0xFEFF)

Start Position	Length	Parameter Name	SPN
1.1	2 bits	Water In Fuel Indicator	97

**APPENDIX D
SUPPORTING INFORMATION**

SPN 16 – Fuel Filter (Suction Side) Differential Pressure

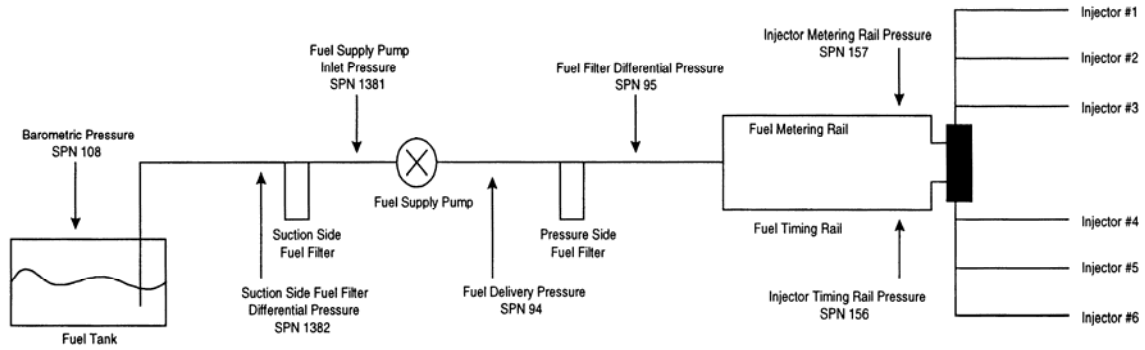

FIGURE SPN16_A - FUEL SYSTEM WITH RAILS

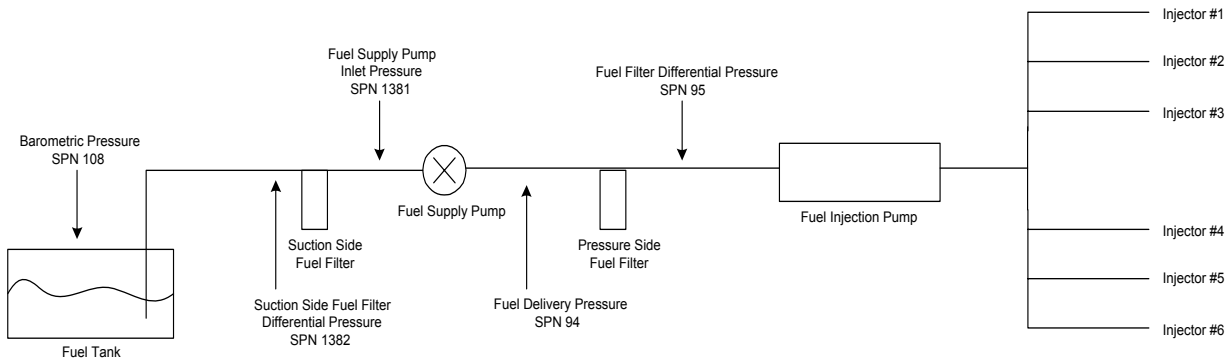

FIGURE SPN16_B - FUEL SYSTEM WITH PUMP

SPN 512 – Driver’s Demand Engine – Percent Torque

Figure SPN512_A and Figure SPN512_B show two typical torque calculations in an engine controller. On the left side of the figures there are single engine controller functions. The output torque signals of these functions are connected in the manner shown. The result is the actual engine percent torque which is realized by the engine.

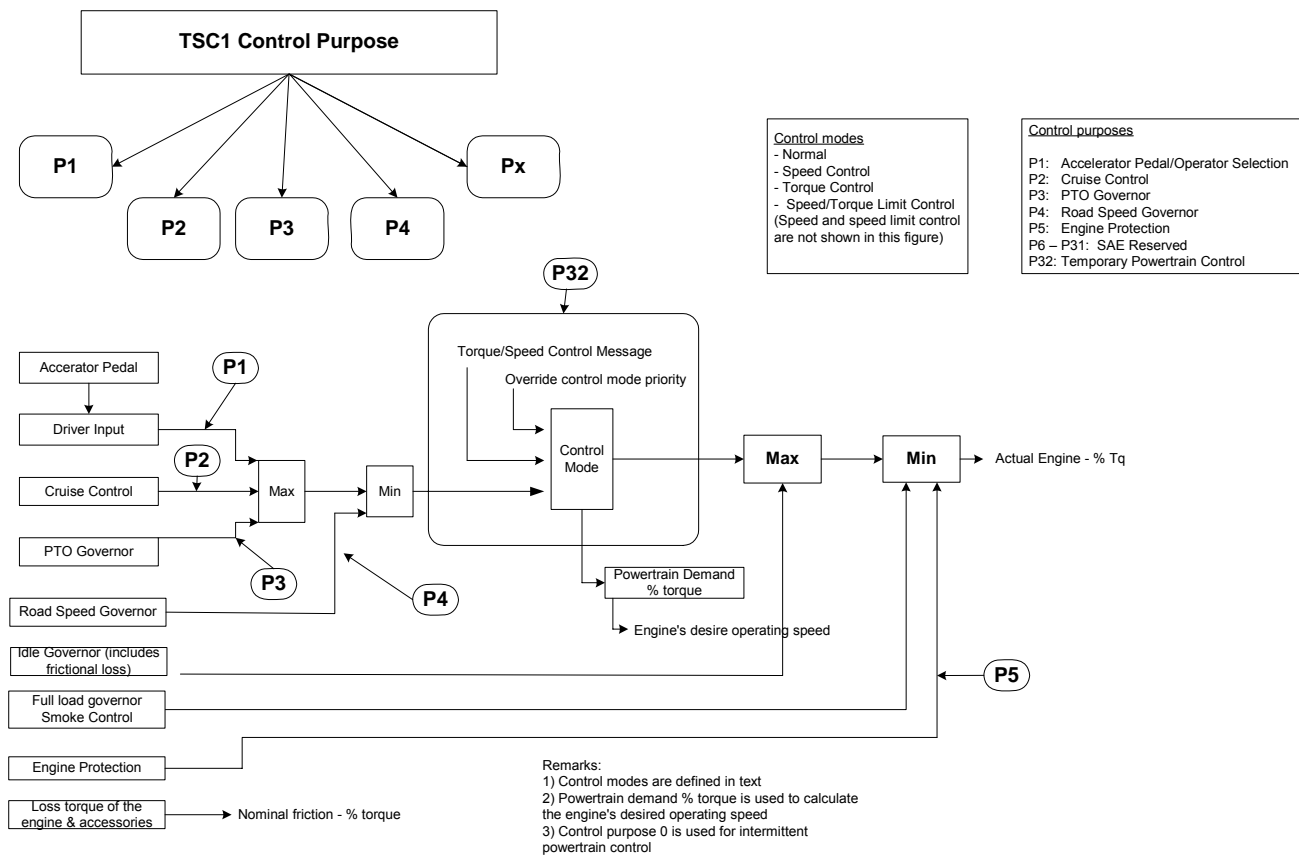

FIGURE SPN512_A - TORQUE COMMANDS AND CALCULATIONS WHEN A “MAXIMUM SELECTION FOR LOW IDLE” TECHNIQUE IS USED

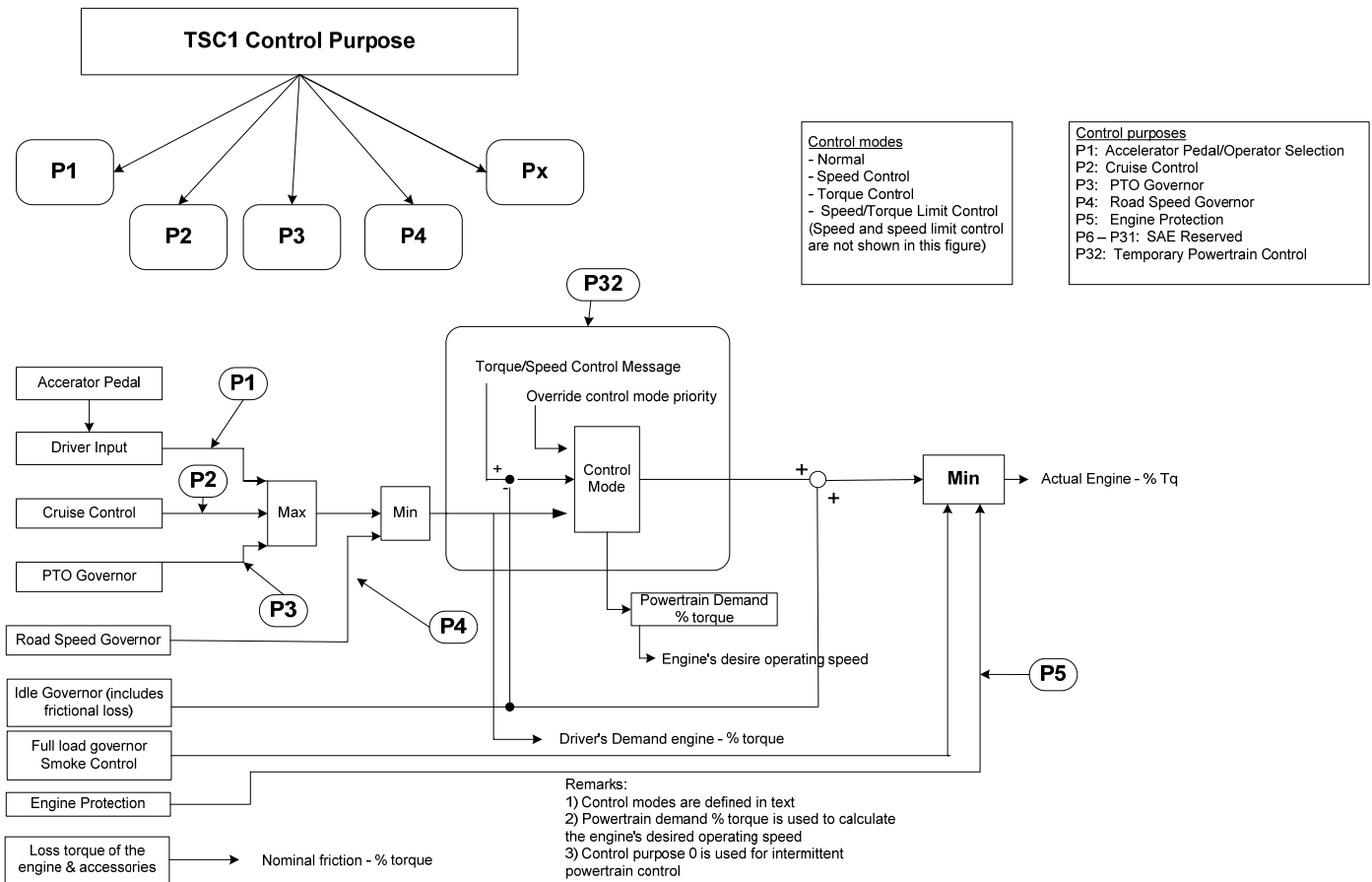

FIGURE SPN512_B - TORQUE COMMANDS AND CALCULATIONS WHEN A "SUMMATION WITH LOW IDLE" TECHNIQUE IS USED

On top of the figures, external torque commands (e.g., traction and transmission control) can control the engine. These commands can influence the engine torque by four control modes. Four engine internal signals are transmitted to the network:

- Driver's demand engine - percent torque
- Actual engine - percent torque
- Nominal friction - percent torque
- Engine's desired operating speed

The difference between Figure SPN512_A and Figure SPN512_B is the connection of the idle governor output to the torque calculation. In Figure SPN512_A there is a maximum selection, while in Figure SPN512_B a summation is used. The summation method needs a subtraction point for each external command input because the starting point of an ASR or a shift operation should be the present actual engine - percent torque value. As the actual engine - percent torque signal contains the idle governor output and the external commands are compared with the driver's demand engine - percent torque or the powertrain demand which don't contain the idle governor output, the external commands must be subtracted by the idle governor output to get the correct signals for comparison.

The advantage of the maximum selection (Figure SPN512_A) is that no other speed controller can work parallel to the idle governor. This allows for a better optimization of the different speed control loops. The advantage of the summation method (Figure SPN512_B) is that changes of the idle governor output influence the engine directly (no dead zones exist).

SPN 518 – Engine Requested Torque/Torque Limit

When preparing to send a request to a retarder, the states of the Retarder Enable - Shift Assist Switch and the Retarder Enable - Brake Assist Switch must be checked by the requesting device to determine whether the request may be sent to the Retarder. Figure SPN518_A shows how those switches and other operator and network inputs are used to create the actual retarder operating point on a system-wide basis. The Retarder may or may not be the device reading the actual switches; even if it is, it will not accept or reject a request based on its knowledge of the switch states. Its function is to send the switch states via J1939 (in its ERC1 message) and it expects other J1939 nodes to honor those switch states by refraining from sending inappropriate commands.

Several elements affect the retarder besides the Requested Torque parameter in the TSC1 message. These elements are not looked at by the retarder itself, but are used by various other devices to determine if they may ask the retarder to be engaged. These are the Retarder Enable Shift Assist Switch, and the Retarder Enable Brake Assist Switch. The relationship between those switches and the retarder (as well as that between the operator and retarder) is described in Figure SPN518_A.

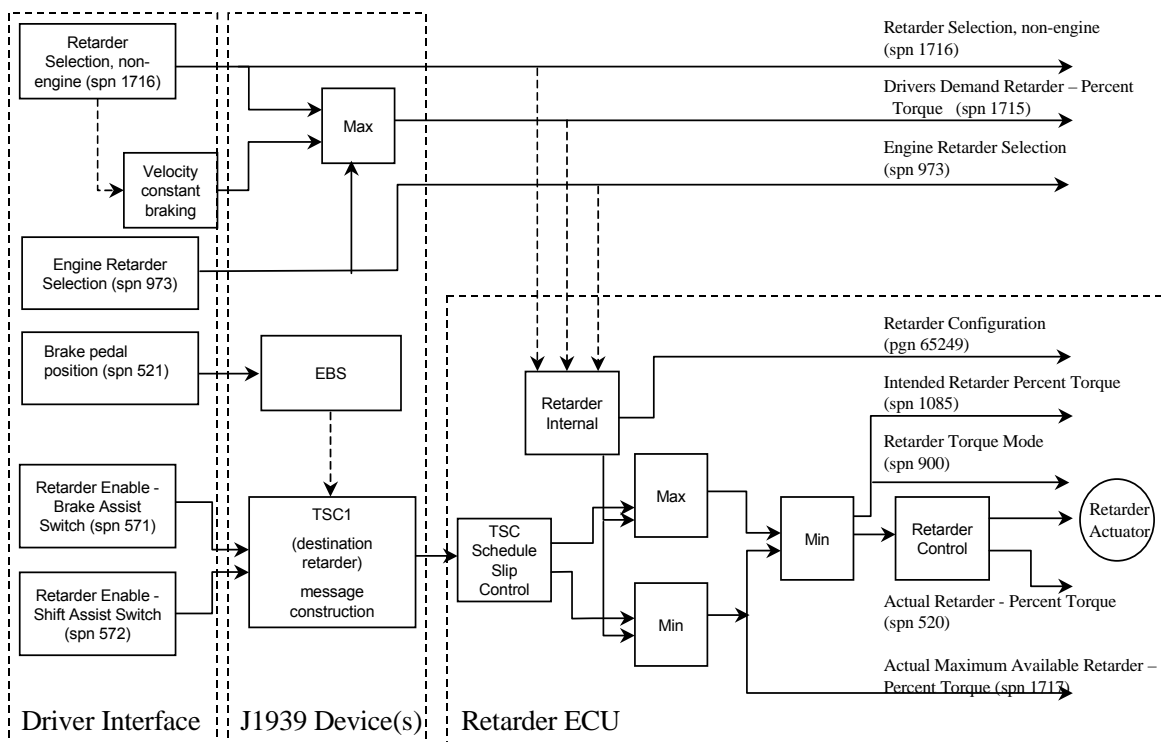

FIGURE SPN518_A - RELATIONSHIP BETWEEN OPERATOR/SWITCH INPUTS AND RETARDERS

Tables SPN518_A and SPN518_B identify many use cases. Each row is the summary of one or more uses. One of the primary communications provided by these tables is that the retarder can be activated by the J1939 TSC1 message, although the operator input is "off."

**TABLE SPN518_A—PRIMARY RETARDER – BEFORE TRANSMISSION
(Compression Release Engine Retarder)**

J1939 Inputs ¹ (TSC1)	Operator Inputs			Outputs	
	Cruise Control ²	Accel Pedal ³	Torque Request Via "Retarder Selection, Engine" ⁴	May Retarder Provide Brake Torque?	Retarder Torque Mode (base 2)
T	Any	Any	Any	No	0000
R	Any	Any	Any	Yes	> 0001
NTR	Any	T	Any	No	0000
NTR	R	ZR	R	Yes	> 0001
NTR	R	ZR	ZR	Yes	0010
NTR	NTR	ZR	R ⁵	Yes ⁵	0001
NTR	NTR	ZR	ZR	No	0000
ZR	Any	Any	Any	No	0000

Key:

T = request positive Torque

R = request Retarder torque

NTR = No Torque Request

ZR = Zero torque Requested by retarder

Any = This value has no bearing whether or not the Retarder is available. The retarder will NOT be available because some other entity is requesting positive torque.

Footnotes:

1. Note that the TSC1 inputs will override Operator Torque Selection. The J1939 devices that generate the TSC1 messages will assure that the Retarder Enable Brake Assist Switch and Retarder Enable Shift Assist Switch are enabled as appropriate before commanding the Retarder to engage. See parameters SPN 571 and 572 for descriptions of these switches. Also, for the purposes of this table, it is assumed that if the TSC1, Destination Retarder message is requesting Retarder Torque, no other TSC1, Destination Engine messages are requesting engine fueling. That arbitration is beyond the scope of this section.
2. This refers to the torque requested by the cruise control, and does not refer to the cruise switches. Cruise control is defined to be on and engaged in this column. The cruise control should not request retarder torque unless the Retarder Enable - Brake Assist Switch is enabled.
3. The Accelerator Pedal is inherently incapable of requesting negative torque. It may have no particular torque demands, or it may request some engine fueling, which prevents the retarder from engaging. Consequently, the chart is complete even though no rows exist for the AP to request retarder torque.

4. The Operator Torque Request is incapable of requesting positive torque. The table is complete without the Operator Torque Request asking for positive Engine Torque
5. This description assumes no other switch (such as brake pedal depressed) is needed in order for the operator torque request to initiate retarder braking. Other implementation specific rules would apply if such a catalyst were needed.

Table SPN518_B shows the relationship between various inputs and an after engine retarder.

The biggest difference between this type of retarder and an engine brake is that the exhaust brake may be engaged while the engine is still being fueled. Also, if cruise control is communicating with the retarder, it would do so using the TSC1 message.

Consequently, columns for accelerator pedal input and cruise control input would only serve to confuse the issue of retarder availability in Table SPN518_B.

TABLE SPN518_B—PRIMARY RETARDER – AFTER ENGINE (EXHAUST BRAKE, HYDRAULIC RETARDER)

Operator Inputs		Outputs	
J1939 Inputs ¹ (TSC1)	Torque Request Via operator torque request ²	May Retarder Provide Brake Torque?	Retarder Torque Mode (base 2)
R	R	Yes	> 0001
R	ZR	Yes	> 0001
NTR	R ³	Yes ³	0001
NTR	ZR	No	0000
ZR	Any	No	0000

Key:

R = request Retarder torque - some amount of braking torque is requested of the retarder.

ZR = Zero Retarder request - Zero percent torque is requested of the retarder

NTR = No retarder Torque Request - No request is being made of the retarder one way or another.

Any = This value has no bearing whether or not the retarder is available. In fact, because of what some other entity is requesting, the retarder will NOT be available.

Footnotes:

1. Note that the TSC1 inputs will override Operator Torque Selection. The J1939 devices that generate the TSC1 messages will assure that the Retarder Enable Brake Assist Switch and Retarder Enable Shift Assist Switch are enabled before commanding the Retarder to engage. Also, for the purposes of this table, it is assumed that if the TSC1, Destination Retarder message is requesting Retarder Torque, no other TSC1, Destination Engine messages are requesting engine fueling. That arbitration is beyond the scope of this section.
2. The Operator Torque Request is incapable of requesting positive torque. The table is complete without the Operator Torque Request asking for positive Engine Torque
3. This description assumes no other switch (such as brake pedal depressed) is needed in order for the operator torque request to initiate retarder braking. Other implementation specific rules would apply if such a requirement were needed.

SPN 519 – Desired Operating Speed Asymmetry Adjustment

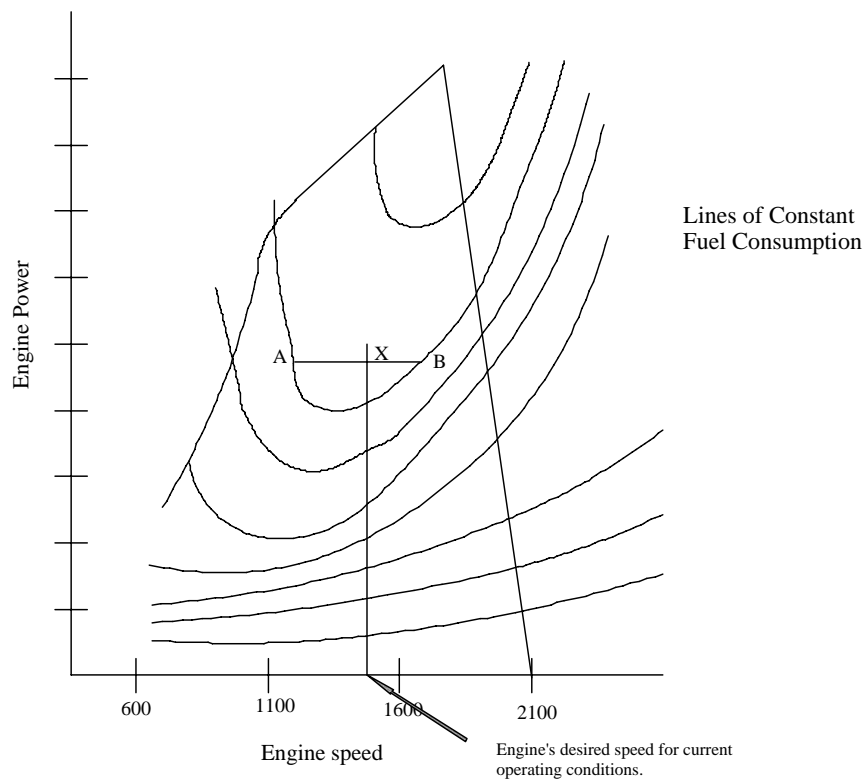

FIGURE SPN519_A—DESIRED OPERATING SPEED ASYMMETRY ADJUSTMENT

SPN 527 – Cruise Control States**TABLE SPN527_A—CRUISE CONTROL STATES**

Bit States	Cruise Control State
000	Off/Disabled
001	Hold
010	Accelerate
011	Decelerate/Coast
100	Resume
101	Set
110	Accelerator override
111	Not available

State Descriptions:

000b Off/Disabled —Used to indicate that the cruise control device is off or on standby. Note that the cruise control system switch does not necessarily have to be off to be in this mode.

001b Hold —Used to indicate that the cruise control device is active and currently maintaining a captured operating speed.

010b Accelerate —Used to indicate that the cruise control device is in the process of ramping up the operating speed.

011b Decelerate —Used to indicate that the cruise control device is in the process of ramping down, or coasting, the operating speed.

100b Resume —Used to indicate that the cruise control device is in the process of resuming the operating speed to a previously captured value.

101b Set —Used to indicate that the cruise control device is establishing the current vehicle speed as the operating speed (captured value).

110b Accelerator Override —Used to indicate that the cruise control device is active but not currently maintaining the captured operating speed.

SPN 564 – Differential Lock Positions

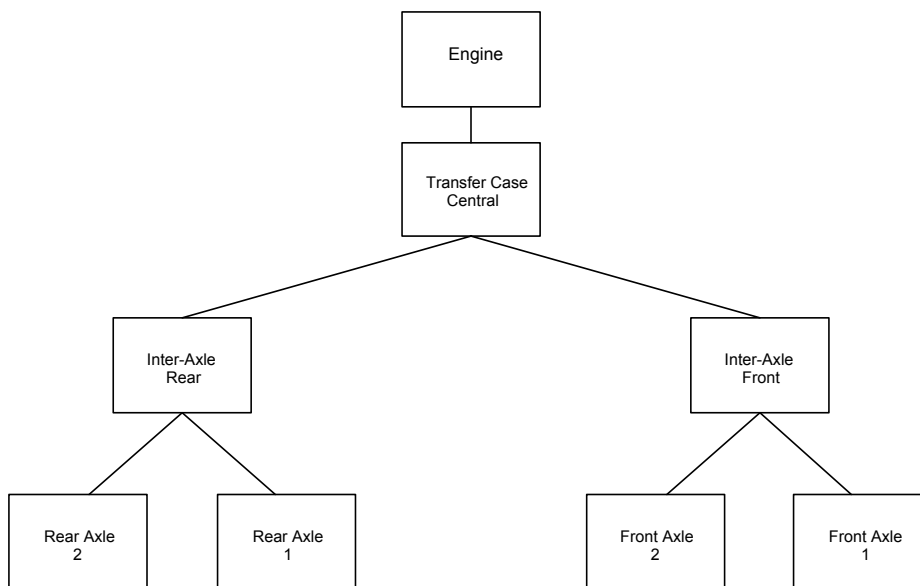

FIGURE SPN564_A—DIFFERENTIAL LOCK POSITIONS

SPN 574 – Shift in Process

FIGURE SPN574_A—SHIFT IN PROCESS

SPN 590 – Idle Shutdown

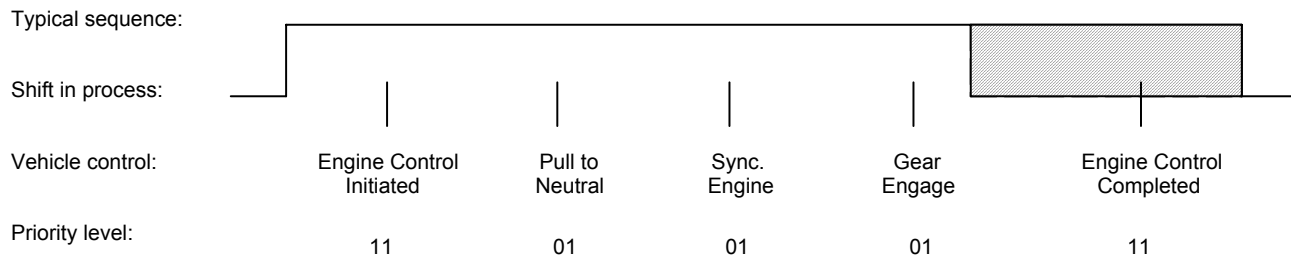
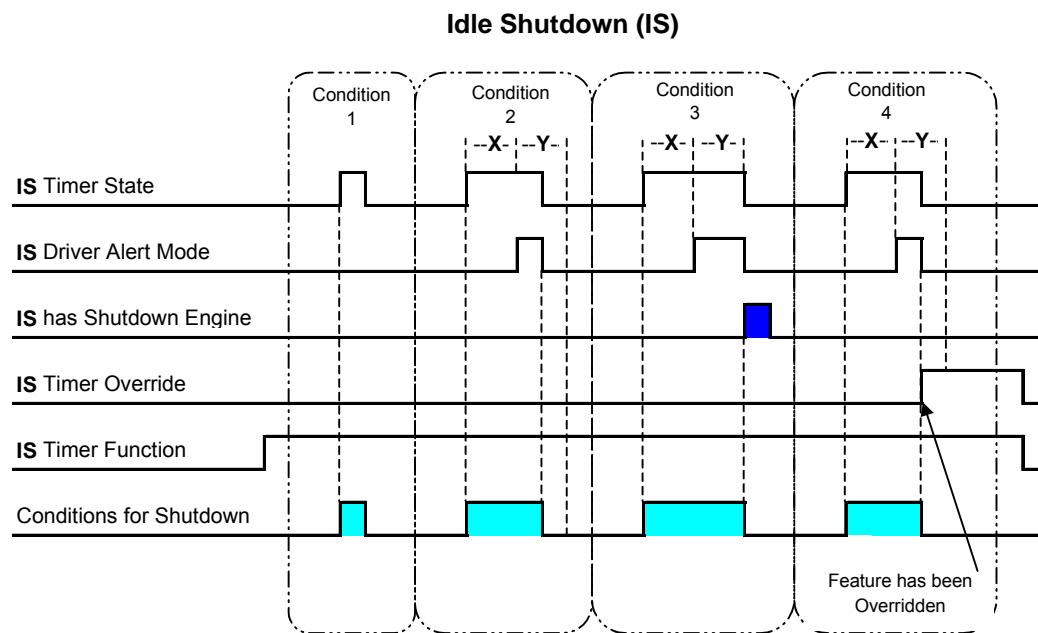

FIGURE SPN590_A—IDLE SHUTDOWN (IS)

Condition 1 - When the IS Timer Override is inactive, the IS Timer State will become inactive if the conditions for shutdown no longer exist before the “X” time interval has expired or IS Driver Alert Mode is activated.

Condition 2 - When the IS Timer Override is inactive, the IS Timer State will become inactive if the conditions for shutdown no longer exist before the IS Driver Alert Mode “Y” time interval has expired.

Condition 3 - When the IS Timer Override is inactive, then the IS has Shutdown Engine will be active after the “Y” time interval has expired.

Condition 4 - When the IS Timer Override is active during the “Y” time interval, then the IS feature shall be overridden and will no longer be available until the system has been re-initiated.

NOTE—0 State – Inactive, disabled in calibration, or conditions for idle shutdown do not exist.

1 State – Active, enabled in calibration, or conditions for idle shutdown do exist.

SPN 695 – Engine Override Control Mode

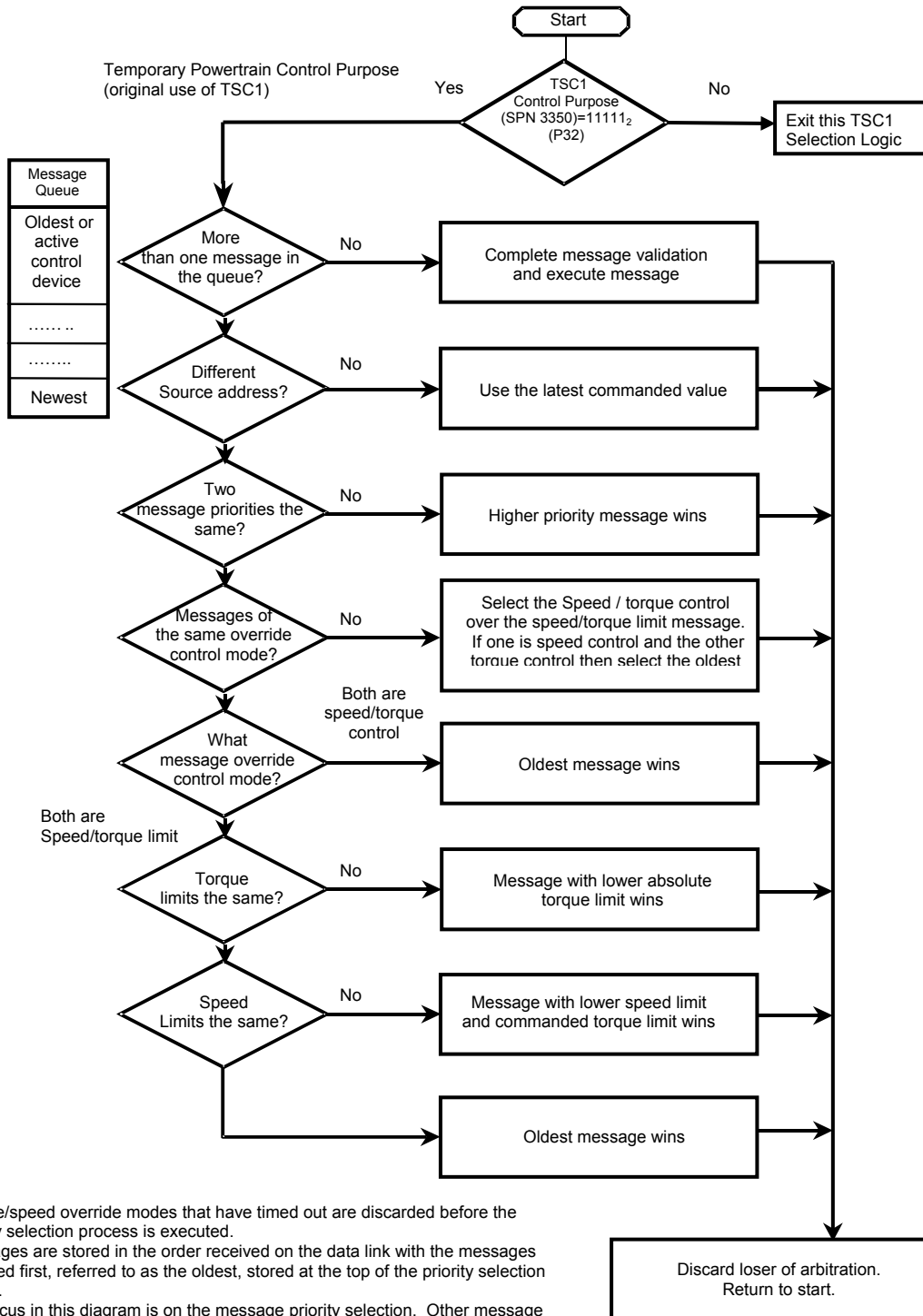

FIGURE SPN695_A—TORQUE/SPEED CONTROL PRIORITY SELECTION LOGIC

SPN 899 – Engine/Retarder Torque Modes

TABLE SPN899_A—ENGINE/RETARDER TORQUE MODES

Bit States	Engine/Retarder Torque Mode
0000	Low idle governor/no request (default mode)
0001	Accelerator pedal/operator selection
0010	Cruise control
0011	PTO governor
0100	Road speed governor
0101	ASR control
0110	Transmission control
0111	ABS control
1000	Torque limiting
1001	High speed governor
1010	Braking system
1011	Remote accelerator
1100	Service procedure
1101	not defined
1110	Other
1111	Not available

State Descriptions:

0000b Low Idle Governor/No request (Default mode) - This mode is active if the accelerator pedal (not necessarily the torque output of the driver input, see Figure SPN512_A and Figure SPN512_B) is zero. This is the default mode. At low speed, the low idle governor may be active while at higher speed, it is zero.

0001b Accelerator Pedal - This mode is active if the accelerator pedal position is active (being followed). This mode is active for the retarder if it is turned on by the operator. Note that it may be disabled by the accelerator pedal or clutch switches (operator selection).

0010b Cruise Control - This mode is active if cruise control is active and greater than the accelerator pedal request.

0011b PTO Governor - This mode is active if the PTO governor is active.

0100b Road Speed Governing - Indicates that road speed governing is active and limiting torque.

0101b ASR Control - Indicates that the ASR command is active (Speed, Torque, or Speed/Torque Limit Control).

0110b Transmission Control - Indicates that the transmission command is active (Speed, Torque, or Speed/Torque Limit Control).

0111b ABS Control - Indicates that the ABS is controlling torque.

1000b Torque Limiting - This mode is active if the demanded or commanded engine torque is limited by internal logic due to full load, smoke and/or emissions control, engine protection and/or other factors. A reduced torque limit may be necessary for engine protection if the engine temperature is too high or a sensor fails (speed, timing, or boost pressure), as examples.

1001b High Speed Governor - This mode is active if the engine is controlled by the high speed governor due to normal operation.

1010b Brake System (Electronic) - This indicates that the brake pedal is controlling the torque. Note that this may include enabling of the retarder when the brake pedal is depressed (touched).

Note that if there is a request to the retarder but operating conditions do not allow braking, this situation will be reflected by the Percent Retarder Torque = 0 when broadcast.

1011b Remote Accelerator - This mode is active if the remote accelerator is controlling engine speed.

1100b Service procedure - This mode is active if the engine is operating in a specific service mode. For example, fuel injection may be disabled to allow a service procedure to crank the engine without fuel injection occurring.

1110b Other - Torque control by a type of device which is different than those defined in states 0000b to 1100b.

SPN 901 – Retarder Type**TABLE SPN901_A —RETARDER TYPES**

Bit States	Retarder Type
0000	Electric/Magnetic
0001	Hydraulic
0010	Cooled Friction
0011	Compression Release (Engine retarder)
0100	Exhaust
0101-1101	Not defined
1110	Other
1111	Not available

Electric/Magnetic Retarder - The electric/magnetic retarder functions by creating eddy currents generated in a conductive armature when placed in a variable magnetic field. Currently, electric retarders have a stator on which field coils are mounted. The rotors, mounted on both sides of the drive shaft, are ribbed for heat dissipation. In order to brake the vehicle, voltage is applied to the field coils which generate a magnetic field inducing eddy currents in the rotors as they pass through the field. Magnetic retarders use a permanent magnet to generate the eddy currents. Braking-torque is dependent on stator excitation and on the air gap between the rotor and the stator.

Hydraulic Retarder - The hydraulic retarder is a hydrodynamic coupling device. Two impellers which face each other, a rotor and a stator, are filled with oil. When the rotor, which is connected to the vehicle drive shaft rotates, it drives the oil in the direction of rotation. The mechanical energy produced by the rotor is converted into kinetic energy in the operating fluid. Hydrodynamic coupling between the rotor and stator converts the kinetic energy into heat and the rotor is retarded. This retardation effect is transmitted to the drive shaft and the vehicle is retarded.

Cooled Friction Brake - The cooled friction brake uses air or hydraulic fluid to dissipate heat from the friction surface of the service brake. By controlling the friction surface temperature, retarding torque is improved, along with a reduced rate of wear.

Compression Release Engine Retarder - The compression release engine retarder converts a power-producing diesel engine into a power-absorbing retarding mechanism by opening the exhaust valve near the top dead center in the engine compression cycle. No positive power will be produced, since the compressed air mass is released. The vehicle is retarded as it must provide energy to compress the cylinder air charge and subsequently to return the piston to the bottom position.

Exhaust Brake - The exhaust brake restricts the escape of the exhaust gas from the exhaust manifold. Each succeeding exhaust stroke builds up a back pressure in the manifold which exerts a retarding effect to the pistons during the exhaust stroke. The engine turns against this back pressure creating a braking effect to the vehicle.

Auxiliary Retarder - Fans, air conditioners, or any power-absorbing device in the vehicle can also function as retarders as they impose parasitic loading on the engine or vehicle.

SPN 911 – Service Component Identification

TABLE SPN911_A—SERVICE COMPONENT IDENTIFICATION

Identification	Component
0	Service check for entire vehicle
1	Brake lining; left front axle
2	Brake lining; right front axle
3	Brake lining; left rear axle
4	Brake lining; right rear axle
5	Clutch lining
6-10	Not defined
11	Brake lining; left rear axle #2
12	Brake lining; right rear axle #2
13	Brake lining; left rear axle #3
14	Brake lining; right rear axle #3
15	Brake lining; general
16	Regulated general check for entire vehicle
17	Brake system special check
18	In-between check
19	Check trip recorder
20	Check exhaust gas
21	Check vehicle speed limiter
22-29	Not defined
30	Engine coolant change
31	Engine coolant filter change
32	Engine oil—engine #1
33	Engine oil—engine #2
34	Not defined
35	Steering oil
36	Not defined
37	Transmission oil — transmission #1
38	Transmission oil — transmission #2
(R) 39	Transmission oil filter — transmission #1
40	Intermediate transmission oil
41	Not defined
42	Front axle oil
43	Rear axle oil
44-47	Not defined
48	Tires
49	Engine air filter
50	Engine oil filter
51	Engine Fuel Filter
52-60	Not defined
61	Tachograph
62	Driver card #1
63	Driver card #2
64-239	Not defined
240-249	Manufacturer specific
250-251	Reserved
252	Reset all components
253	No action to be taken
254	Error
255	Component identification not available

SPN 988 – Trip Group 1

TABLE SPN988_A—TRIP GROUP 1

Parameter	SPN
Trip distance	244
Trip fuel	182
High resolution trip distance	918
Trip compression brake distance	990
Trip service brake applications	993
Trip maximum engine speed	1013
Trip average engine speed	1014
Trip drive average load factor	1015
Trip average fuel rate	1029
Trip average fuel rate (Gaseous)	1031
Aftertreatment 1 Trip Fuel Used	3733
Aftertreatment 1 Trip Active Regeneration Time	3734
Aftertreatment 1 Trip Disabled Time	3735
Aftertreatment 1 Trip Number of Active Regenerations	3736
Aftertreatment 1 Trip Passive Regeneration Time	3737
Aftertreatment 1 Trip Number of Passive Regenerations	3738
Aftertreatment 1 Trip Number of Active Regeneration Inhibit Requests	3739
Aftertreatment 1 Trip Number of Active Regeneration Manual Requests	3740
Aftertreatment 2 Trip Fuel Used	3741
Aftertreatment 2 Trip Active Regeneration Time	3742
Aftertreatment 2 Trip Disabled Time	3743
Aftertreatment 2 Trip Number of Active Regenerations	3744
Aftertreatment 2 Trip Passive Regeneration Time	3745
Aftertreatment 2 Trip Number of Passive Regenerations	3746
Aftertreatment 2 Trip Number of Active Regeneration Inhibit Requests	3747
Aftertreatment 2 Trip Number of Active Regeneration Manual Requests	3748
Parameter Group	PGN
Aftertreatment 2 Trip Information	64888
Aftertreatment 1 Trip Information	64889
Trip time information #2	65200
Trip time information #1	65204
Trip shutdown information	65205
Trip vehicle speed/cruise distance information	65206
Trip fuel information (Gaseous)	65208
Trip fuel information	65209
Trip distance information	65210
Trip fan information	65211

SPN 1014 – Trip Average Engine Speed

The equation is as follows:

$$\text{Trip average engine speed} = \frac{\sum_{i=0}^N \text{RPM}(i)}{N} \quad (\text{Eq.SP1014_A})$$

where:

RPM is the engine speed at sample i , N is the number of samples of engine speed and is proportional to the current trip elapsed time

SPN 1085 – Intended Retarder Percent Torque

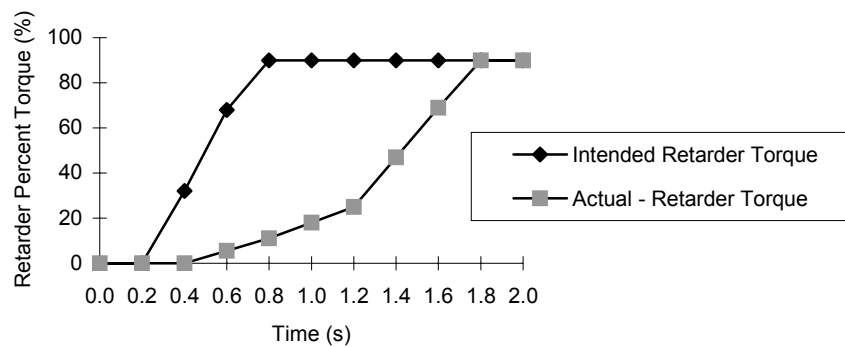

FIGURE SPN1085_A—INTENDED RETARDER PERCENT TORQUE

SPN 1107 – Engine Protection System Timer State

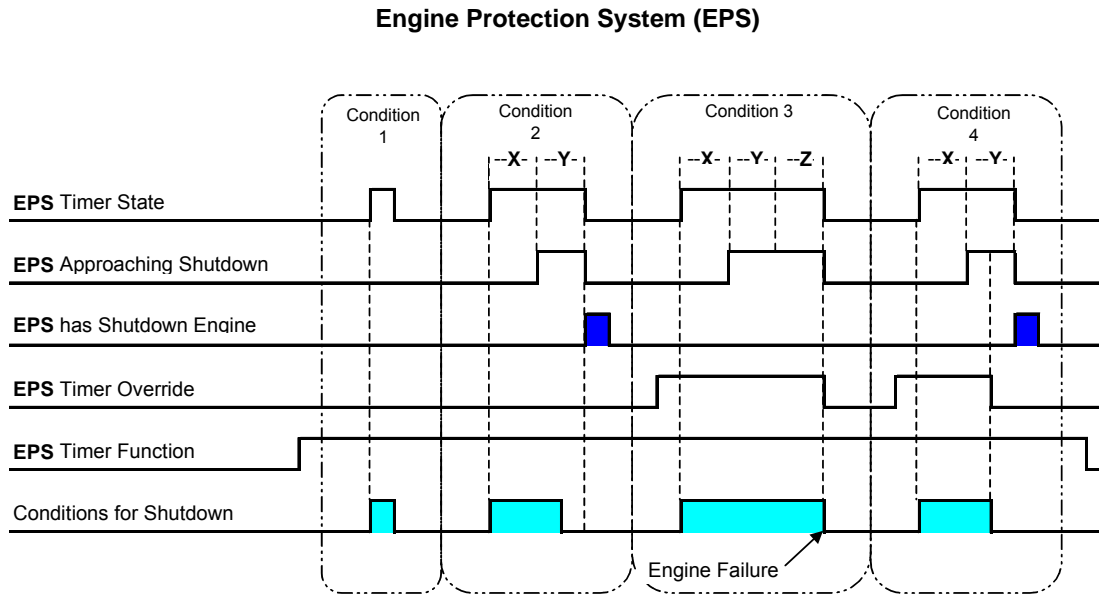

FIGURE SPN1107_A—ENGINE PROTECTION SYSTEM (EPS)

Condition 1 – When the EPS Timer Override is inactive, the EPS Timer State will become inactive if the conditions for shutdown no longer exist before the "X" time interval has expired or EPS Approaching Shutdown is activated.

Condition 2 – When the EPS Timer Override is inactive and conditions for shutdown exist during the "Y" time interval, then the Engine will shutdown, even though shutdown conditions subside before the "Y" time interval has expired.

Condition 3 – When the EPS Timer Override is active, then the EPS feature shall be overridden allowing for an engine failure when the "Z" time interval has expired.

Condition 4 – When the EPS Timer Override is active and then allowed to go inactive during the "Y" time interval, the response by the EPS shall be the same as condition 2. The time intervals for "X" and "Y" shall always start when conditions for shutdown first commence regardless whether the EPS Timer Override is enabled or not.

NOTE: 0 State – Inactive, disabled in calibration, or conditions for Engine Protection do not exist.

1 State – Active, enabled in calibration, or conditions for Engine Protection do exist.

SPN 1734 – Nominal Level Front Axle

FIGURE SPN1734_A: EXAMPLE FOR NOMINAL LEVELS

If the vehicle height, to be controlled by the ASC, is not within the tolerances of the defined nominal levels, the nominal level is set to not specified.

The defined vehicle heights can be activated via the ASC 2 (PGN: 53760) message or via a remote control (see figure SPN1734_B). The remote control is an external unit to operate the suspension system.

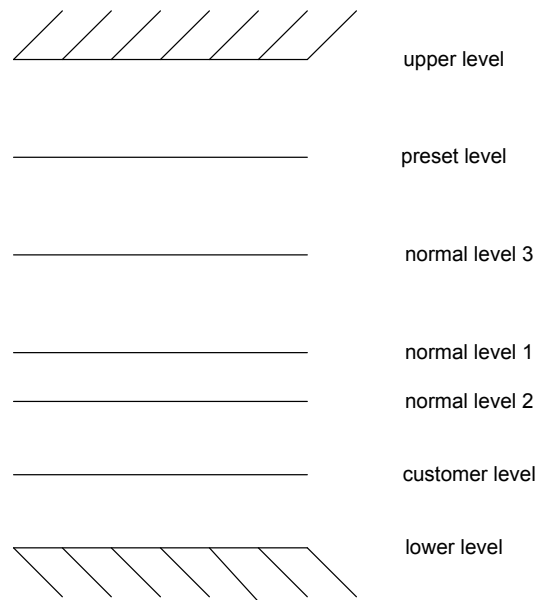
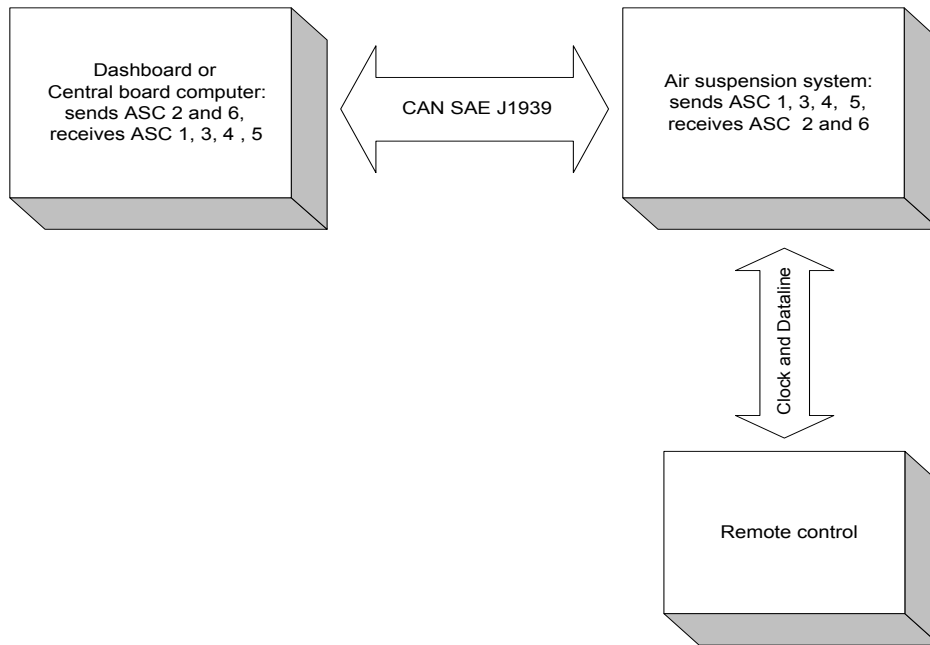

FIGURE SPN1734_B: POSSIBLE INTEGRATION OF ASC SYSTEM INTO VEHICLE NETWORK

An example: The nominal level is the normal level 1. Via remote control a new nominal level (for instance upper level) is requested. The nominal level is then set to upper level and during the height modification the ASC is indicating that the actual level is below nominal level until the upper level is reached.

SPN 2432 – Engine Demand - Percent Torque

Background:

During periods of TSC#1 engine control, other devices on the J1939 network may wish to know where the engine wants to go once it is released from TSC#1 control. In order for option transitions of driveline torque between different devices, it becomes necessary to understand the *engine's* desired torque for all phases of a TSC#1 control sequence.

Driver's Demand Engine – Percent Torque (SPN 512) provides a partial prediction of the torque the engine wishes to produce after a TSC#1 command is removed. Included in Driver's Demand Torque are external requestors to the powertrain such as accelerator pedal, cruise control, and road speed limit governors. However, *excluded* from DDT are (1) dynamic commands within the powertrain such as smoke control, noise control, and low and high speed engine governing, and (2) external TSC#1 commands to the engine such as those generated by traction control.

For a controller to properly determine the engine's desired output torque during a TSC#1 sequence, it needs knowledge of the torque being scheduled by all active controls within the engine. Since DDT excludes many of these active controllers from its calculation, it cannot be used to accurately predict the desired output torque. The effects of the external TSC#1 commands can be approximated by other devices by means of monitoring TSC#1 messages to the engine; however the effects of the engine's internal dynamic commands are completely unknown and cannot be estimated.

Actual Engine – Percent Torque (SPN 513) provides a window to the engine's desired torque output when no TSC#1 commands are actively controlling the engine. However, when the engine is responding to TSC#1 commands, the Actual Engine – Percent Torque parameter is no longer indicative of the torque that the engine will produce once those TSC#1 commands are removed.

In simplest terms, Engine Demand – Percent Torque (or "EDT") contains the engine's internal dynamic commands that are excluded from the Driver's Demand Engine – Percent Torque definition, including smoke control, noise control, and low and high speed governing. With this additional piece of information, devices on the network that are controlling the engine via TSC#1 messages can determine the torque direction of the engine once the current TSC#1 command is relinquished.

It is important to note that the proposed EDT parameter is used as information. The addition of the EDT parameter should in no way cause a change to the engine's actual torque command architecture.

EDT Calculation:

When no devices are controlling the engine via TSC#1 messages, the value of EDT is equal to the Actual Engine – Percent Torque parameter. When the engine is being controlled via a TSC#1 message, it is necessary for the engine controller to calculate what its' target torque *would be* if there were no external commands being received. This "runner up" in engine control will come from internal dynamic engine commands.

In the calculation of Actual Engine – Percent Torque, the output of the engine's idle governor must be considered, along with the impact of the engine's full load governor, smoke controls and other internal limiting logic. In the determination of the Engine Demand Torque parameter, these same engine logic components are needed, as indicated in Figure SPN 2432_A. However, there is a significant difference: These components only affect the Actual Engine – Percent Torque parameter determination if they are the component *actively* controlling the engine. In EDT, any of these components will be used to calculate EDT if they are the "*runner up*" for engine control. Even though these components may lose in the engine's internal control arbitration, the engine output torque that they would produce if in command needs to be found to determine EDT.

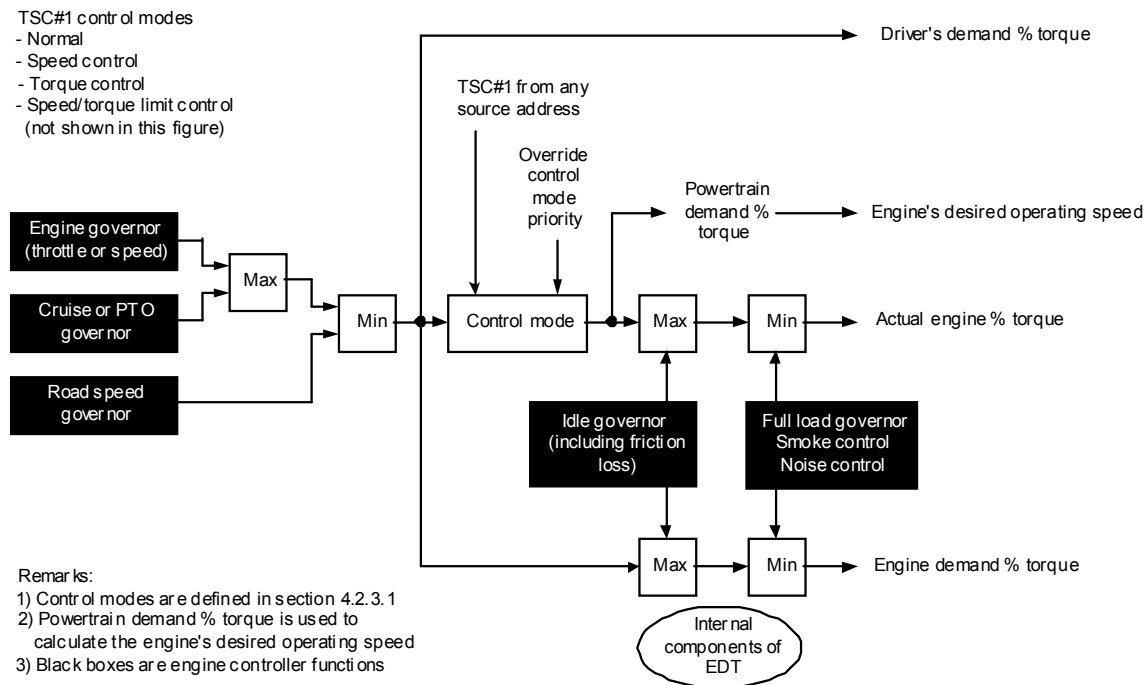

FIGURE SPN2432_A – TORQUE COMMANDS AND CALCULATIONS WHEN A “MAXIMUM LOW IDLE” TECHNIQUE IS USED

If speed governors are involved in determining these components of the EDT calculation, any of the following 3 special cases may need to be addressed:

Special Case #1: Speed Governors

If the engine governor referenced in Figure SPN2432_A is a speed-based governor instead of a throttle table arrangement, a new challenge is presented in determining EDT. Since the speed governor output is directly influenced by the TSC#1 command (for example, integrator anti-windup logic), the speed governor's output during TSC#1 commands cannot be used to calculate EDT.

Instead, an *approximation* of the speed governor output without the effects of any TSC#1 commands is required for use in the EDT calculation. “Approximation” refers to removing the effects of integrator terms and any other dynamic components that result from the controlling TSC#1 commands. All elements affecting the speed governor reference should be included before the reference is translated into terms of torque.

All control algorithms with dynamic elements (e.g., speed governors) that execute during TSC#1 commands need to have their outputs replaced by “steady-state” approximations for use in the EDT calculation. Again note that these approximations are for use only in the EDT calculation; the actual engine control logic remains unchanged.

Figure SPN2432_B illustrates EDT and speed governor output during a typical control sequence. The output of the speed governor may tend to lag the engine's torque trace during and after the TSC#1 command sequence. Note however that the TSC#1's influence is not factored into EDT; only when the command sequence ends or is no longer winning in terms of engine control arbitration do the dynamic effects of the speed governor(s) appear in the EDT signal.

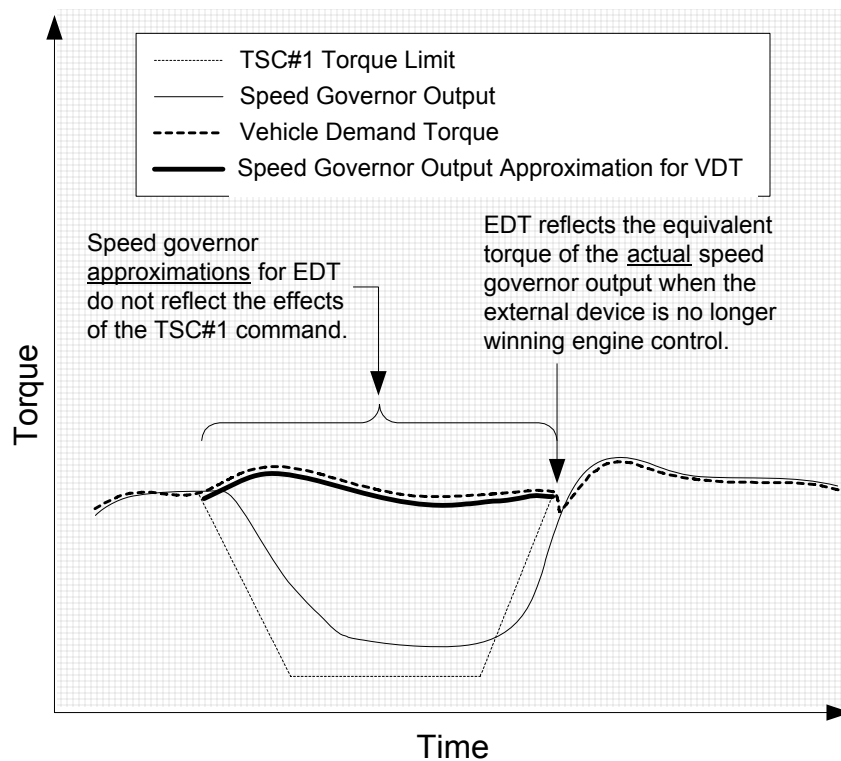

FIGURE SPN2432_B – EDT AND SPEED GOVERNOR OUTPUT RELATIONSHIP DURING A CONTROL SEQUENCE

One method of converting the speed governor reference to torque is shown in Figure SPN2432_C. The inputs of current engine speed, accelerator pedal position and the shape of the governor droop curves can be used to find the equivalent torque output of the governor. A lookup table or calculation could be used.

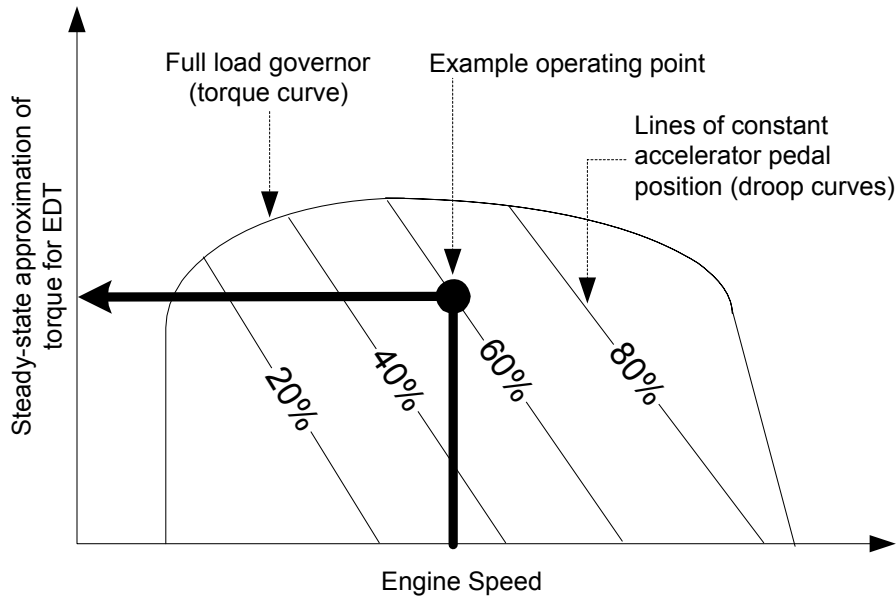

FIGURE SPN2432_C - FINDING EDT TORQUE APPROXIMATION FOR A SPEED GOVERNOR

Special Case #2: “Steep” or zero droop speed governors

Using a steady-state approximation with a “steep” or zero droop speed governor can cause large EDT changes over small speed changes. For example, if a cruise control governor has a zero droop and the vehicle speed is just below the cruise set speed, the steady-state torque approximation using the method described previously is very large. If vehicle speed increases a small amount to above the cruise set speed, the steady-state torque approximation becomes very small or zero.

As a result, a more accurate steady-state torque approximation is needed when steep droop governors are involved. A steep droop speed governor is defined as having a droop slope greater than 0.2% actual torque per rpm as seen below in Figure SPN2432_D.

The following method can be used to determine a steady-state torque approximation for steep or zero droop governors with fast responding integrator anti-windup / integrator resetting:

Upon a TSC#1 message actively controlling engine torque, save the last value of torque commanded by the speed governor (τ_{SG0}) and the last value of speed governor error (ϵ_{SG0}).

During this control sequence, calculate speed governor error (ϵ_{SGi})

Calculate an estimated torque for EDT determination use: $\tau_{SG\text{estimated}} = \tau_{SG0} + K_{pSG} * (\epsilon_{SG0} - \epsilon_{SGi})$

where K_{pSG} is the speed governor proportional gain

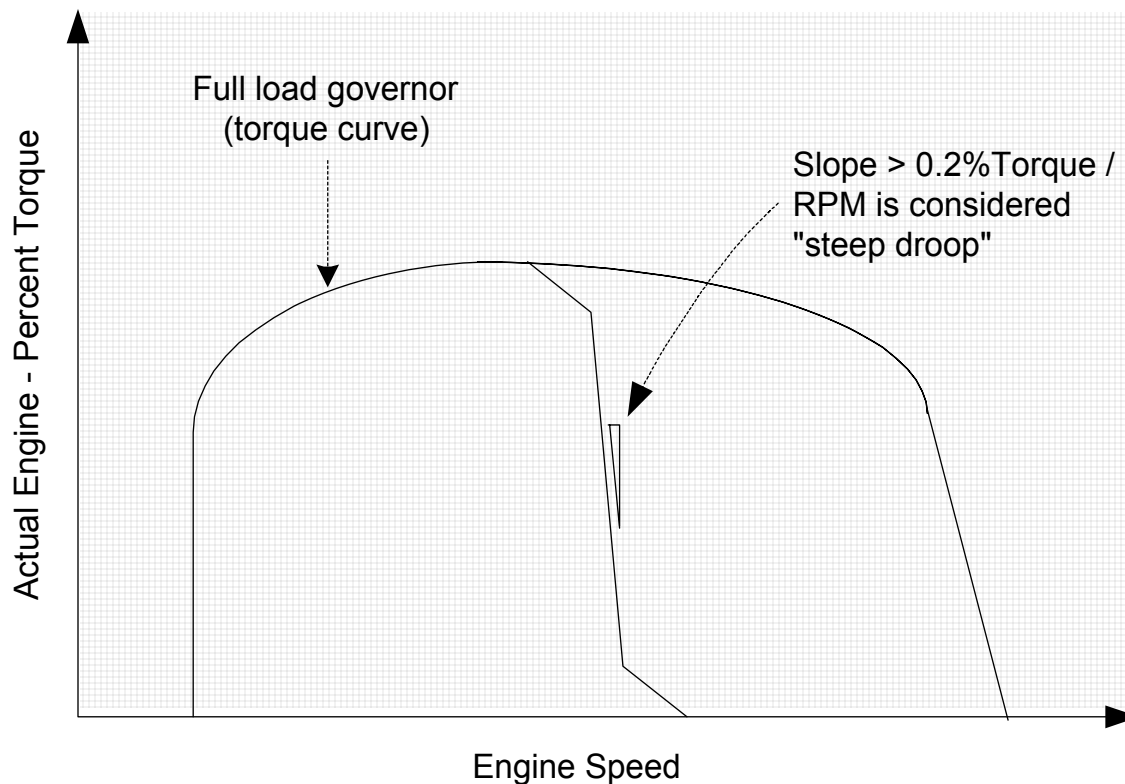

FIGURE SPN2432_D - EXAMPLE OF "STEEP DROOP" SPEED GOVERNOR

Special Case #3: "Slow Response" Speed Governors

If the speed governor dynamic elements are slow to respond to a 1 second torque derate, then the speed governor can simply be executed during the TSC#1 event and the output used directly in determining EDT. This is an alternative for a speed governor which does not contain an integrator, or if the integrator anti-windup logic is slow to respond. A guideline for "slow response" is that the governor output after 1 second of torque limiting has only moved 1/3 of the way to the limit, as shown for example in Figure SPN2432_E.

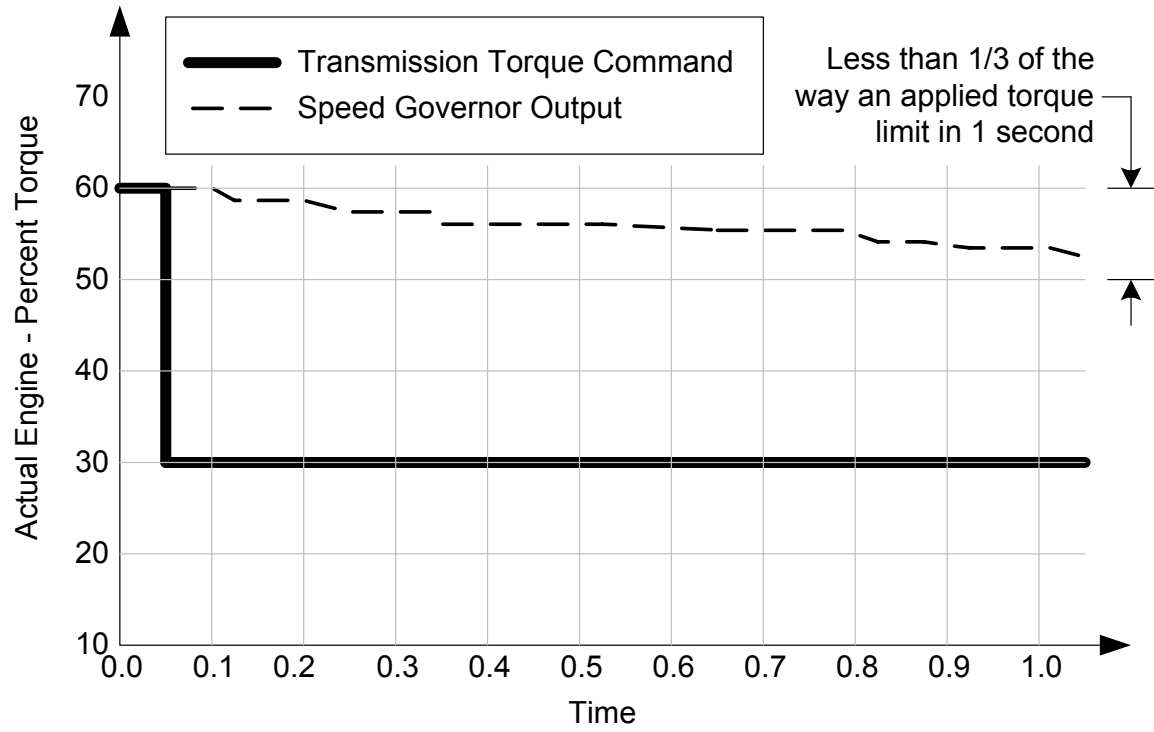

FIGURE SPN2432_E – EXAMPLE OF “SLOW TO RESPOND” SPEED GOVERNOR

SPN 2927 - Actual Inner wheel steering angle

Following sketch shows an example for the actual inward wheel angles of the steering axles in the requested PGN :

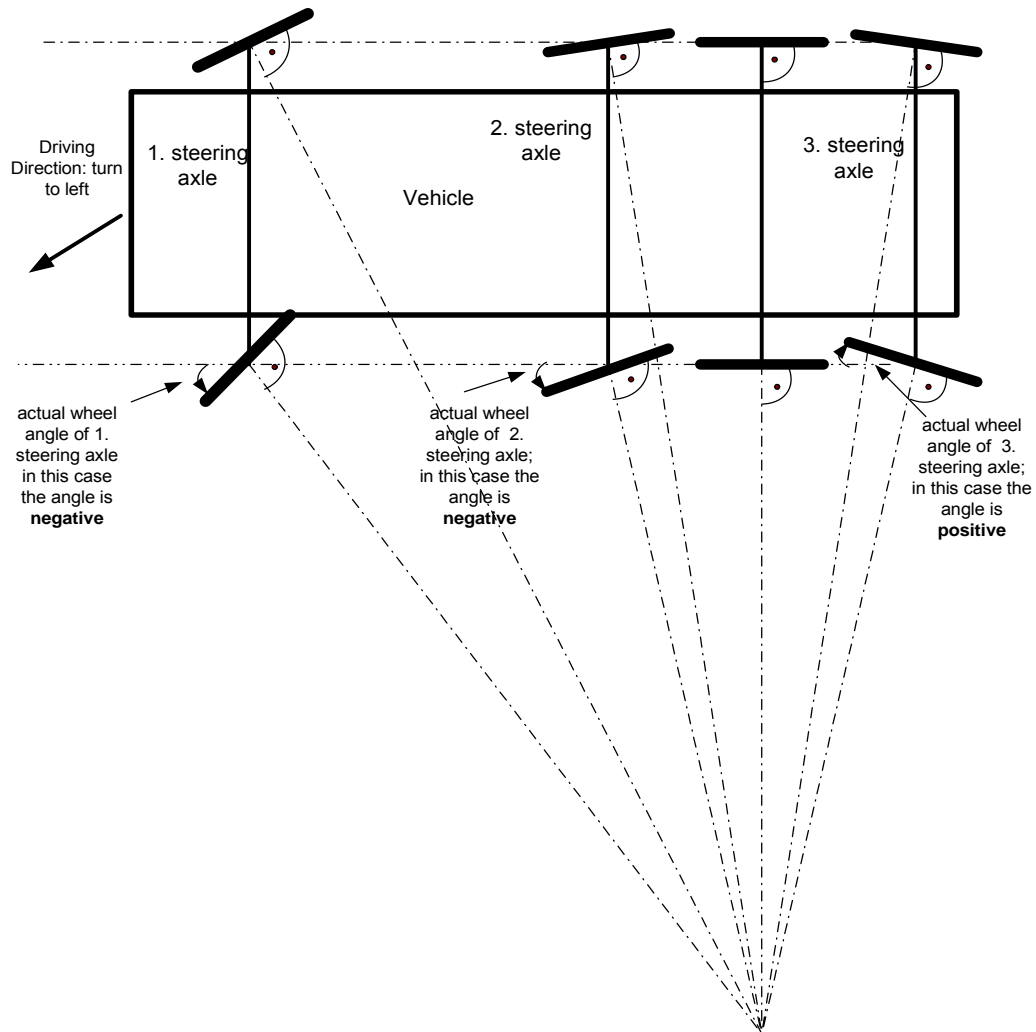

FIGURE SPN2927_A: STEERING AXLE ORIENTATION

SPN 3697 – Diesel Particulate Filter Lamp Command

State of Regeneration Cycle		SAE J1939 Parameters					DM1 Message
		SPN 3697 - Diesel Particulate Filter Lamp Command	SPN 3698 - Exhaust System High Temperature Lamp Command ¹	SPN 3703 - Diesel Particulate Filter Active Regeneration Inhibited Due to Inhibit Switch	SPN 3700 - Diesel Particulate Filter Active Regeneration Status	SPN 3701 - Diesel Particulate Filter Status	
1	Regeneration not needed	000	000	00	00	000	Per active DTCs
2	Regeneration needed – Request Level	001	000	00	10	001	Per active DTCs
3	Regeneration needed – Warning Level	100	000	00	10	010	Per active DTCs
4	Regeneration needed - Service Level	100	000	00	10	011	Per active DTCs. Amber Lamp shall be on with active DTC indicating regeneration level.
5	Regeneration needed – Stop Level	100	000	00	10	011	Per active DTCs. Red Lamp shall be on with active DTC indicating regeneration level.
6	Manual Regeneration Request Acknowledge	Per Filter Status - lamp will reflect actual level of DPF fill.	000	00	At transition. Change to 01 following switch input.	Per appropriate regeneration needed level	Per active DTCs
7	Regeneration active with exhaust temperature above a threshold	Per Filter Status - lamp will reflect actual level of DPF fill.	001	00	01	Per appropriate regeneration needed level	Per active DTCs
8	Regeneration active with exhaust temperature below a threshold	Per Filter Status - lamp will reflect actual level of DPF fill.	000	00	01	Per appropriate regeneration needed level	Per active DTCs
9	Regeneration Inhibit Acknowledge	Per Filter Status - lamp will reflect actual level of DPF fill.	Per exhaust temperature.	At transition. From 00 to 01 following switch input.	The following is for information only during this state: If SPN 3700 is equal to 01, then it will change from 01 to the appropriate state following switch input. If it is not equal to 01, then value remains the same.	Per appropriate regeneration needed level	Per active DTCs

The diesel particulate filter (DPF) thresholds used in the explanations below are relative to each other in the following manner: Request Level < Warning Level < Service Level < Stop Level

1. Regeneration not needed: Amount of particulate matter in DPF is below the request level threshold.
2. Regeneration needed - Request Level: Amount of particulate matter in DPF has exceeded request level threshold, but has not exceeded the warning level threshold.
3. Regeneration needed - Warning Level: Amount of particulate matter in DPF has exceeded warning level threshold, but has not exceeded the service level threshold.
4. Regeneration needed - Service Level: Amount of particulate matter in DPF has exceeded service level threshold, but has not exceeded the stop level threshold.
5. Regeneration needed - Stop Level: Amount of particulate matter in DPF has exceeded stop level threshold.
6. Manual Regeneration Request Acknowledge: When the operator sets the SPN 3696 Diesel Particulate Filter Regeneration Force Switch to 01, then SPN 3700 will indicate that regeneration is active.
7. Regeneration active with exhaust temperature above a threshold: Needs no explanation.
8. Regeneration active with exhaust temperature below a threshold: Needs no explanation.
9. Regeneration Inhibit Acknowledge: If the operator has activated the Diesel Particulate Filter Regeneration Inhibit Switch (SPN 3695), then another device on the network can detect this event by monitoring SPN 3703 to change from 00 to 01.

The actual values of all thresholds referenced above are defined by the manufacturer.

Note ¹: In addition to the above table, the exhaust system high temperature lamp can be set due to high exhaust temperatures that are independent of a regeneration cycle.

FIGURE SPN3697_A – DIESEL PARTICULATE FILTER LAMP COMMAND

SPN 3785 – Tractor Brake Stroke System

The brake stroke system has essentially two inputs:

- 1) Sensor at each actuator that allows the determination of 3 regions of stroke (Fully Returned, Normal Stroke Range, or Overstroke Range)
- 2) A sensor to detect the use of the brake pedal (similar to Stop Light Switch)

The ECU then determines the brake stroke status as follows:

		Brake Pedal	
		OFF	ON
		Stroke Sensor	RETURNED
NORMAL	Dragging		OK
OVERSTROKE	Dragging		Overstroke

FIGURE SPN3785_A – Tractor Brake Stroke Definitions

(R) SPN 4151 – Engine Exhaust Gas Temperature Average

Up to 3 different exhaust port temperature averages will be computed. These three averages include the left bank average exhaust port temperature, the right bank average exhaust port temperature and the engine average exhaust port temperature. The example below illustrates how these averages would be computed for a V8 engine configuration. Inline engines would utilize SPN 4151 for Engine Average Exhaust Temperature.

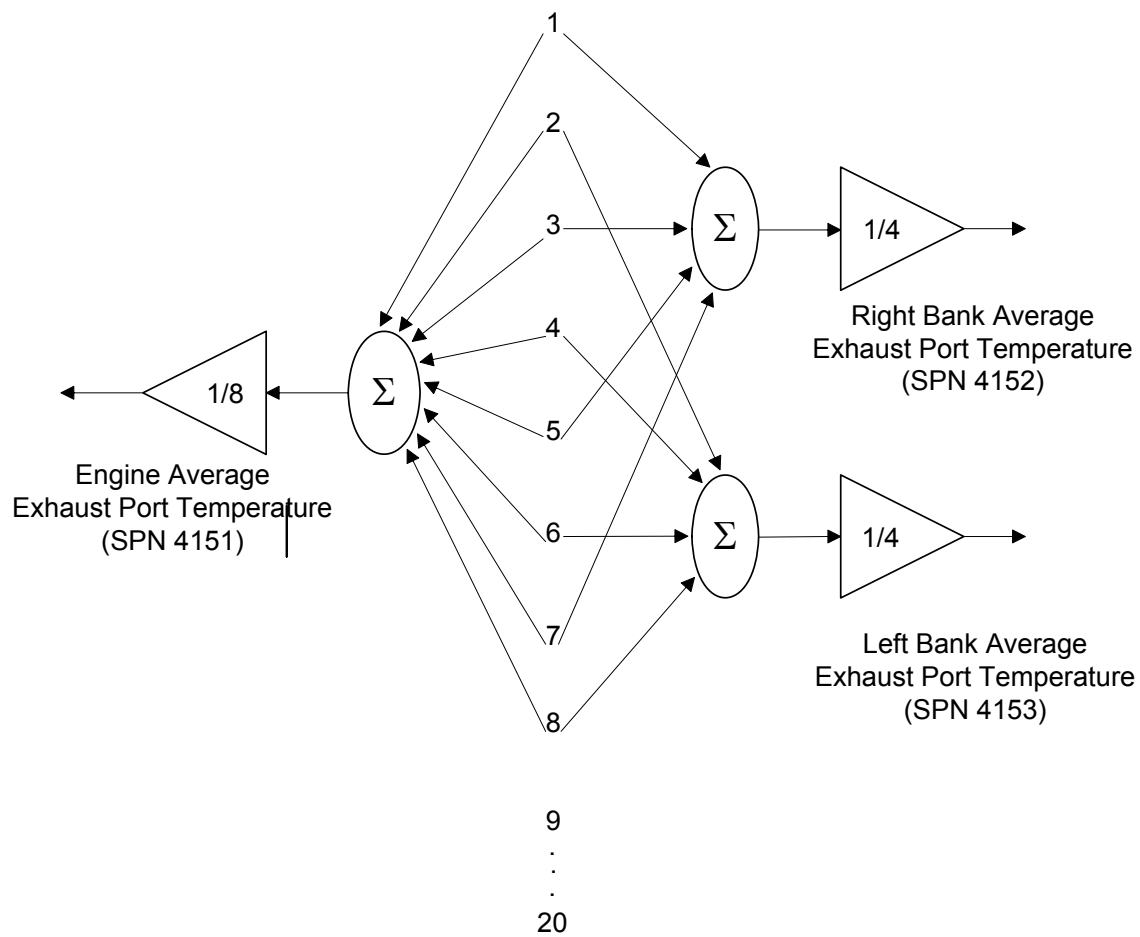
**FIGURE SPN4151_A – Engine Exhaust Gas Temperature Averaging Method**

PGN 1024 – External Brake Request

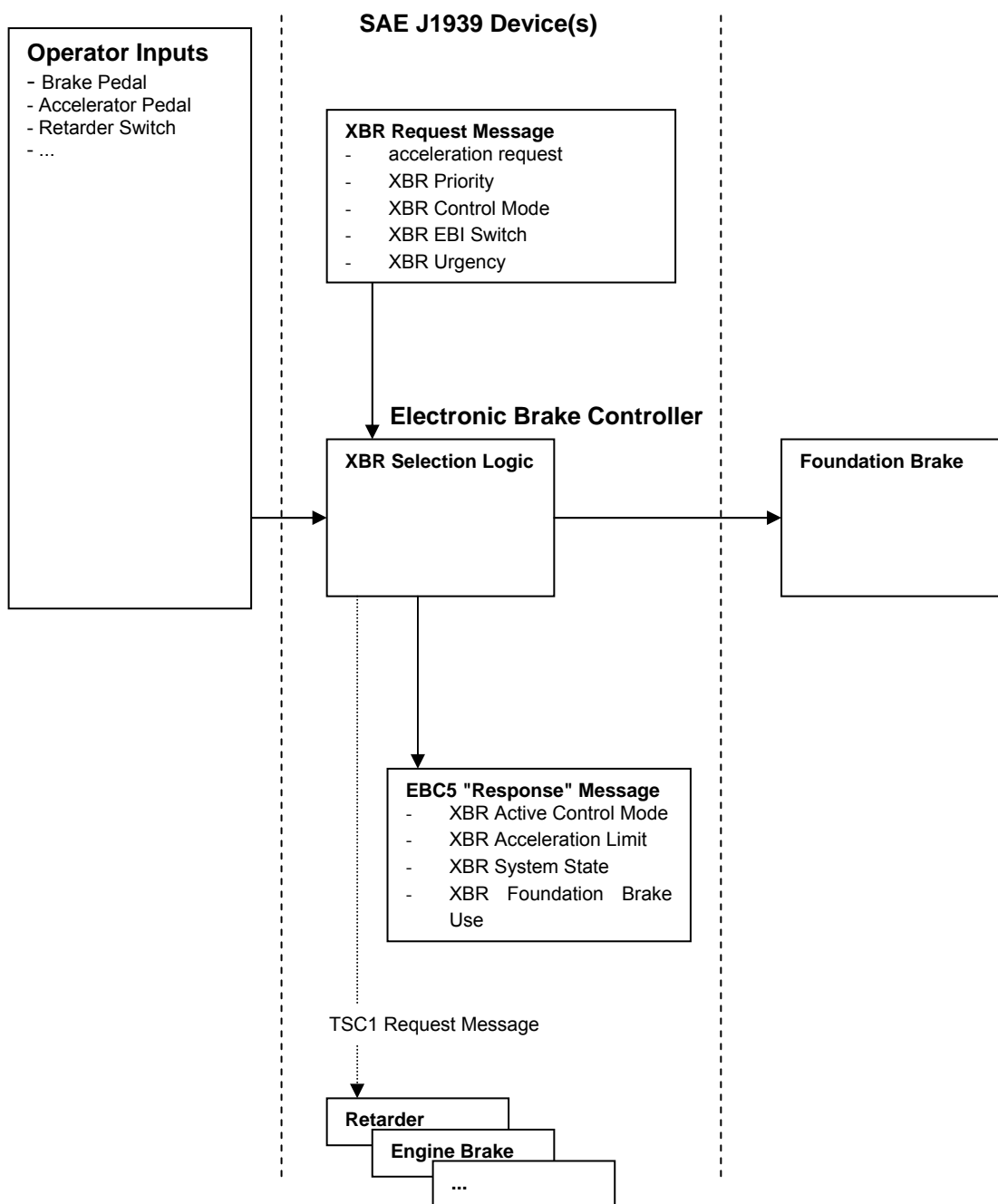
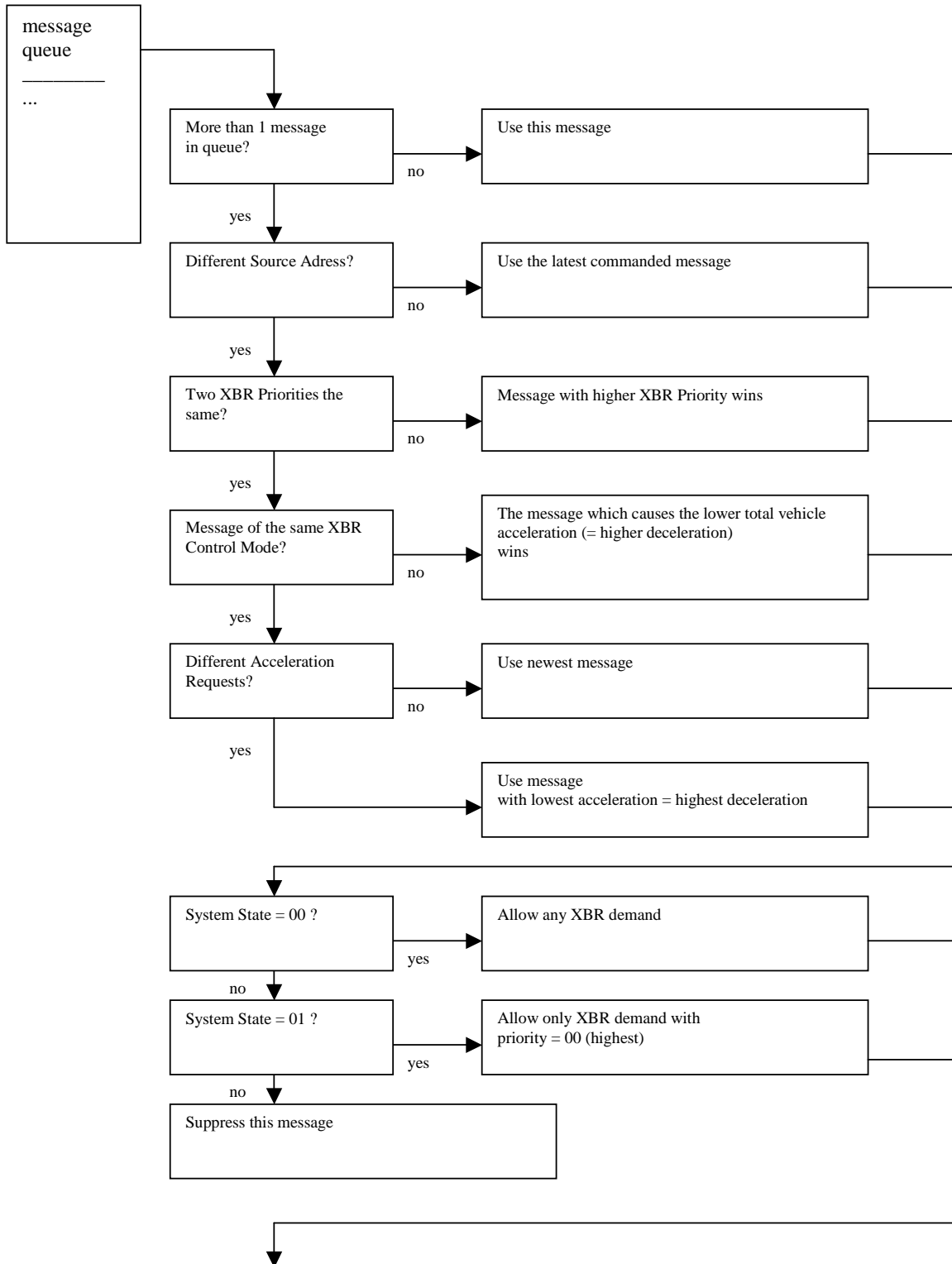

FIGURE PGN1024_A - DATA FLOW DIAGRAM FOR EXTERNAL BRAKE REQUEST

FIGURE PGN1024_A - Data Flow Diagram for External Brake Request



(Continued on next page)

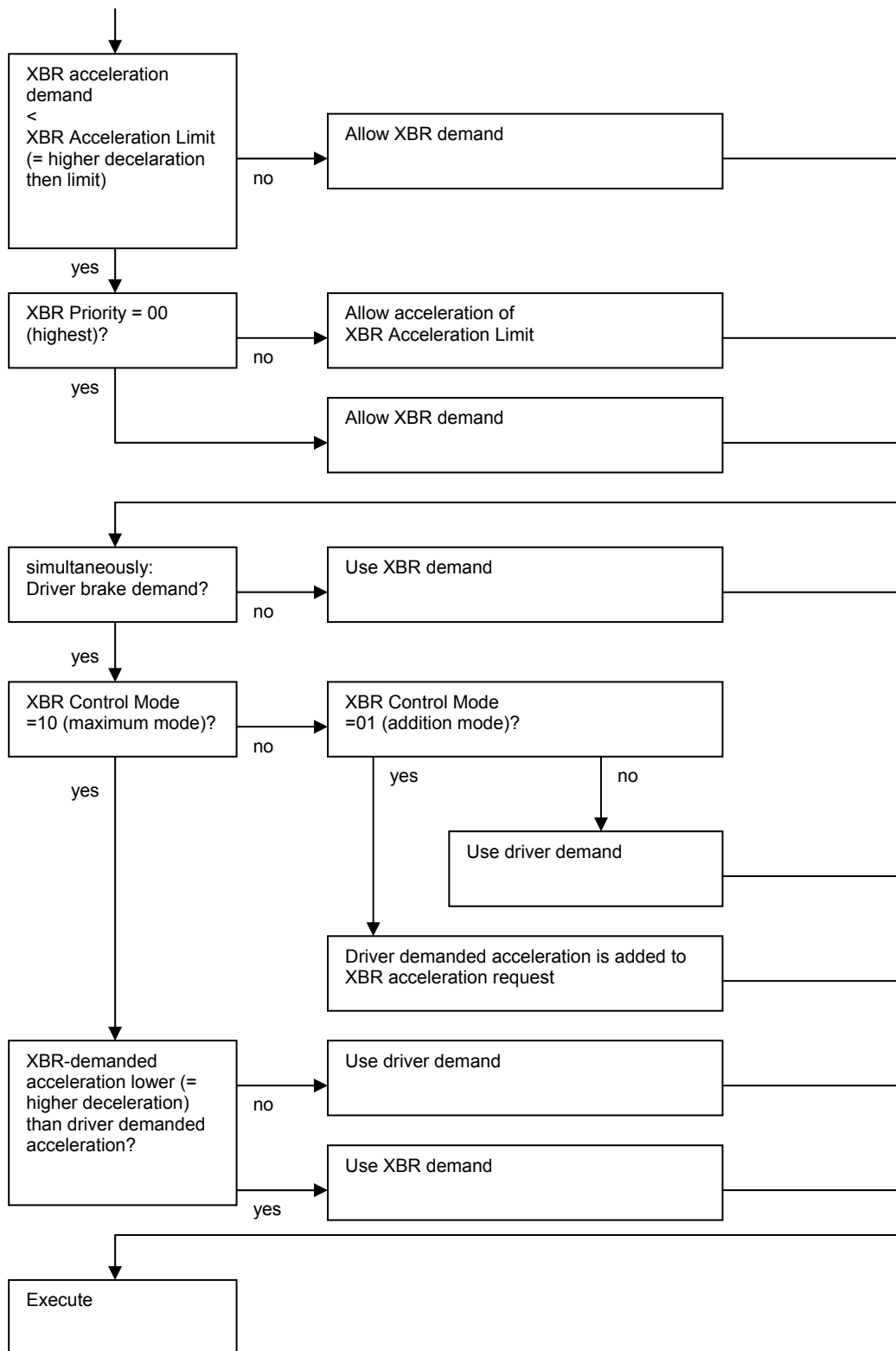

FIGURE PGN1024_B - XBR PRIORITY SELECTION LOGIC

(R) PGN 39680 – Proprietary Messaging Information

This PGN allows an ECU to report basic information about its data methods for the PropA, PropA2, and PropB messages for ECUs to determine proprietary messaging compatibility. Once proprietary messaging compatibility is determined through this PGN, then those ECUs could rely upon messages within that compatible proprietary space to negotiate more specific details of compatibility, such as the set of messages specifically supported and the data dictionary details. An accurate assessment of the proprietary messaging compatibility between ECUs in a network is vital to avoiding system operational hazards resulting from improper interpretation of proprietary messages.

Using the J1939 Proprietary Messages (PropA, PropA2, and PropB) for communications between ECUs in a system requires ECUs to determine which, if any, of the other ECUs support and use the same data methods (i.e. data dictionary, ID assignments, data field structures, etc). Presently, the only SAE J1939 standardized data available to ECUs for determining such proprietary messaging compatibility is the Manufacturer Code parameter in the J1939 NAME reported in the address claim message. This information is marginally sufficient for ECUs to limit proprietary messaging use with peer ECUs of the same Manufacturer Code. However, this information is not sufficient when proprietary messaging is needed between ECUs with different Manufacturer Codes.

Using proprietary messages to communicate between ECUs from different manufacturers requires design time negotiations between manufacturers to establish the data dictionary, message IDs, etc. Often only a small range of message IDs are sectioned off for these interactions and the rest of the proprietary space in each ECU is the native proprietary language of that manufacturer. When using the PropA and PropA2 messages, an ECU can restrict to only those sent specifically to its address and validate the Manufacturer Code and other NAME elements of the Source Address before applying the negotiated methods. However, it is possible that the negotiated language for the sectioned off IDs is applicable by each manufacturer for those specific components, and such space may have different language rules for other components or similar components on other systems. When using the PropB messages, an ECU can only cross reference the Manufacturer Code and other NAME elements of the Source Address. However, it is not possible to determine how the message source has encoded the message or if the source even intended for the ECU to use the message. Consequently, the J1939 NAME is not really sufficient for determining any compatibility for the PropA, PropA2, and PropB messages.

Notes

The data field consists of zero or more Proprietary Method data structures. Each Proprietary Method data structure consists of a Manufacturer Code parameter and a Method ID parameter. The J1939 Manufacturer Code values (J1939 Table B10) shall serve as the enumeration standard for the Manufacturer Code. The Method ID parameter is a 21-bit value defined and set by the manufacturer.

Each Proprietary Method structure allow an ECU to essentially say "This ECU supports Manufacturer X's Proprietary Method '123' ". Since the message supports the ability to report multiple Proprietary Methods, this structure allows an ECU to essentially say:

```
"This ECU supports  
Manufacturer X's proprietary method '123'  
Manufacturer X's proprietary method '456'  
Manufacturer Y's proprietary method '321' "
```

In the above example, Manufacturer X method 123 (X-123) might be for PropA messaging and may have a set of the rules for discovering further PropA proprietary details. Those ECUs with X-123 knowledge will be able to perform the discovery and possibly initiate messaging conversations using the X-123 methods. The Manufacturer X method 456 (X-456) might be for PropA2 messaging and may have a set of the rules for discovering further PropA2 proprietary details. Similarly, those ECUs with X-456 knowledge will be able to perform the discovery and possibly initiate messaging conversations using the X-456 methods. Finally, an ECU could limit acceptance and interpretation of proprietary messages only to those ECUs that indicate specific Proprietary Methods. When establishing proprietary messaging between ECUs with different manufacturer codes, the parties can establish the Proprietary Method ID which indicates the use of the that specific negotiated messaging.

A destination specific message is requested to allow an ECU to customize its message response for the requesting device.

This is a standardized mechanism for an ECU to report a listing of the manufacturer specific (i.e. proprietary) methods it supports when using the PropA, PropA2, and PropB PGNs. The ability to support multiple manufacturer proprietary methods allows manufacturers to collaborate on application specific communication needs that are not of interest to the SAE J1939 committee. The process of selecting a specific method for ECUs that list multiple mutually exclusive methods is intended to be defined by the manufacturer and therefore not within the scope of this PGN.

NOTE—The placement of the Manufacturer Code and Method ID bits into the 4-byte space is illustrated in Figure PGN39680_A.

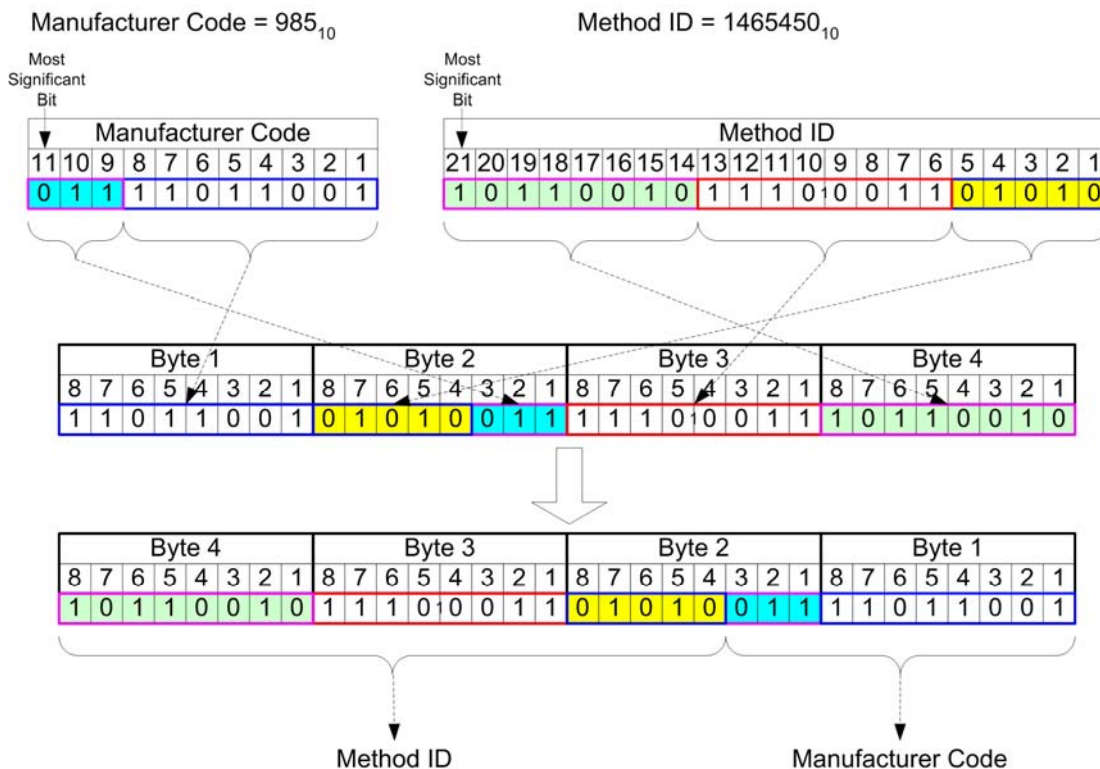

Figure PGN39680_A - Placement of Manufacturer Code and Method ID Data

EXAMPLE 1—The following illustrates the message format for when there are more than one proprietary method to report.

Given:

- a = Manufacturer Code
- b = Method ID

Message form is as follows: a,b,a,b,a,b,a,b,etc. In this example, the transport protocol of SAE J1939-21 has to be used to send the information because it requires more than 8 data bytes. Actually any time there is more than two methods to report, the services of the transport protocol have to be used.

PGN 52992 – Continuous Torque & Speed Limit Request

The TSC1 message allows J1939 network devices to temporarily control engine and retarder speed and torque. This approach allows engine (and retarder) speed to be controlled by one device for a limited period of time. This may need to happen for brief emergency conditions (as requested by an anti-lock braking system for example) or in order to synchronize engine speed with some other device such as a transmission in order to allow a shift. Conflicting speed and torque requests from different devices are resolved by a predefined arbitration scheme.

Not every torque or speed need is satisfactorily addressed by this plan, however. Occasionally a network device may wish to impose longer lasting limits on speed and torque. For instance, as long as a transmission is in third gear, it may not be able to withstand all the torque the engine (or retarder) can produce. Or, an auxiliary device such as a pump may only operate correctly if engine speed and torque are kept within some fairly limited range *but not necessarily at one precise speed/torque!* In these cases, the network device does not need to command the precise speed or torque, but does have a legitimate desire to keep it within some boundary for an extended period of time. The TSC1 message doesn't provide this ability.

How: The ECM and retarder controller(s) first must define a "window" within the torque map. The window should be chosen carefully, and shouldn't be any larger than necessary. Any requests for continuous limits that attempt to intrude on this window will succeed only in setting limits at the very threshold of the window. For example, if the ECM declares that minimum continuous torque limits must be less than 900 lb-ft, and some device attempts to set a minimum continuous torque of 1000 lb-ft, the actual applied continuous limit will be 900 lb-ft (thus 900 lb-ft is the *minimum continuous* torque). When this limit is applied, the engine will always produce at least 900 lb-ft of torque. Similarly, if the engine declares that minimum continuous engine speed cannot be more than 1100 RPM, any attempts at setting a minimum continuous engine speed of over 1100 RPM will result in a minimum continuous engine speed of 1100 RPM. That is, the engine has declared beforehand that it will *always* be able to operate at least at 1100 RPM.

Periodically, the ECM and retarder controller(s) will transmit the dimensions of this window, as well as what actual continuous limits have been applied. This allows the engine to adjust the size and shape of the "window" to allow for derates and provides feedback to the various devices requesting continuous torque and/or speed limits.

The following figure shows an example torque curve with a "window" inside.

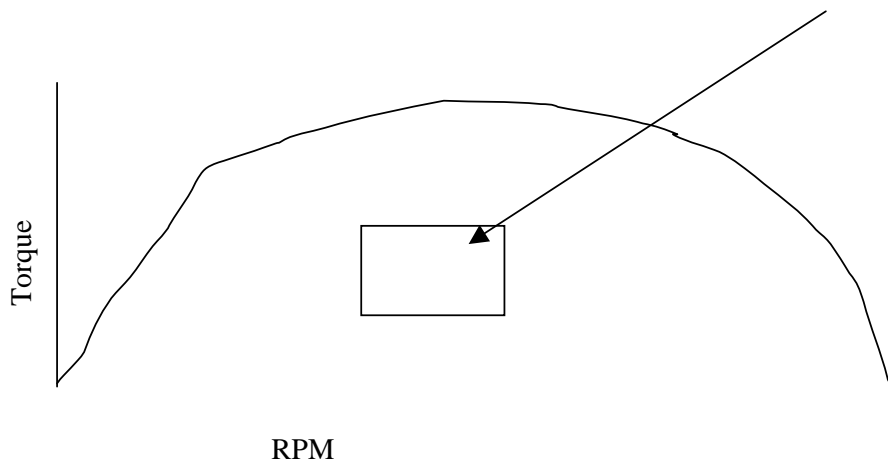

FIGURE PGN52992_A

The following figure shows how the ECM will treat requests that are outside of the bounds set by the “window.” Note that the ECM has declared a “maximum allowable minimum” and a “minimum allowable maximum” for both speed and torque. These limits form a sort of rectangular “window” within the torque. The engine **must** be free to operate within this window; no continuous limits will be accepted that would intrude on it. In the diagram, some network device has ignored those values and attempted to set a minimum continuous speed higher than allowed. Remember, a minimum continuous speed means that the engine must always maintain an RPM of that value or greater. The ECM cannot accept the requested limit, so it applies a continuous limit as close as possible: right at the boundary set by “maximum value allowed for minimum continuous speed.” Requests for Minimum Continuous Speed and Max/Min continuous torque are handled the same way.

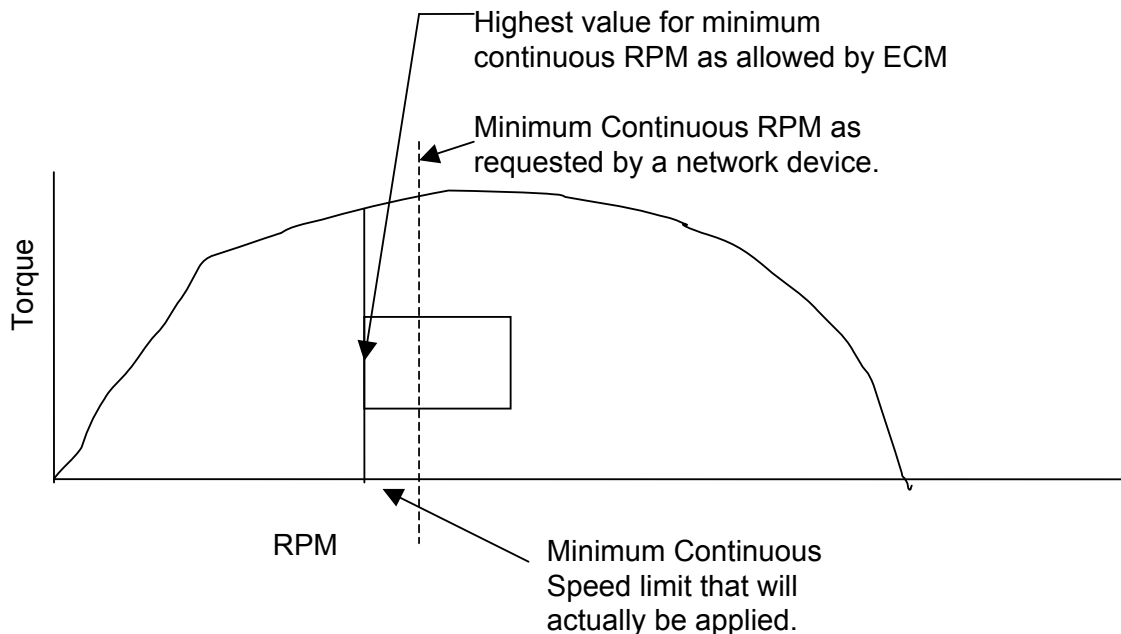

FIGURE PGN52992_B

Things get a little more complicated when a retarder is included. Fortunately, only the engine compression brake retarder has any real relationship to the engine’s torque map. Because other retarders may work against the engine, only the compression brake is generally controlled by the same ECU. For this reason, we must give it more careful attention.

The following figure illustrates one of the problems. Suppose continuous limits have been applied to the engine and retarder as indicated by the rectangular boxes within the torque maps. If the engine is prohibited from allowing torque to decrease below x , how can the retarder be engaged? An engine compression brake retarder needs zero fueling for the engine in order to engage. The simple answer is that if there is a minimum continuous torque limit applied to the engine, the retarder will not be engaged.

How does the reverse case behave? If the retarder is of a type other than engine compression brake, it may work against the engine and continuously produce a negative torque. Engine compression brake retarders must not send out a list of acceptable limits that would allow such conundrums. In practical terms, this means that engine compression brake retarders must set their Maximum Continuous Torque limit (think of it as MINIMUM continuous BRAKING torque limit) to zero in order for the retarder to ever be engaged. Similarly, the continuous limits as actually applied to the engine must allow zero torque if the retarder is to be engaged.

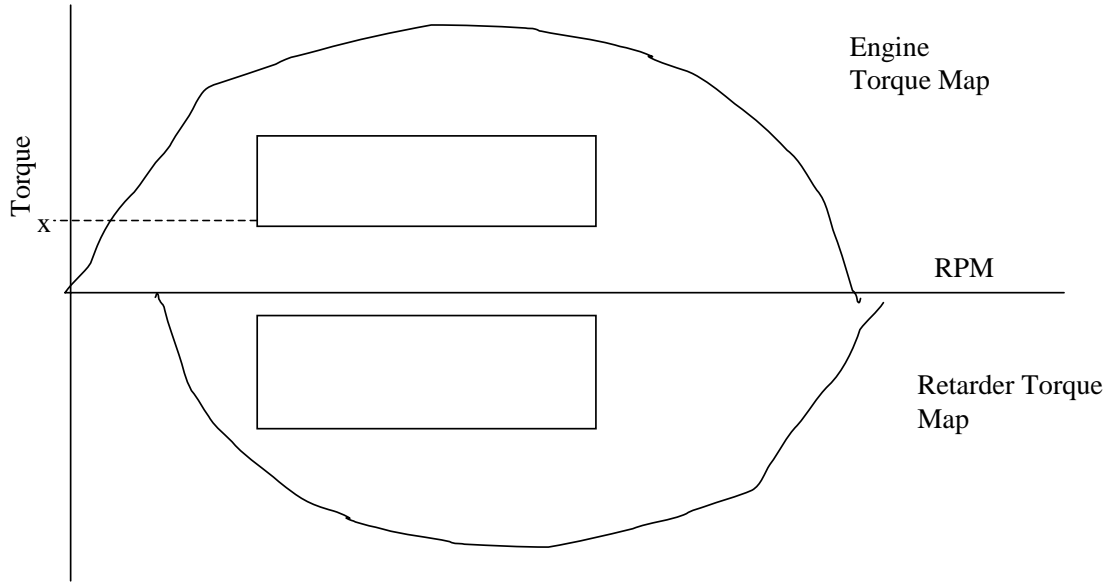

FIGURE PGN52992_C

PGN 56320 – Anti-Theft Status

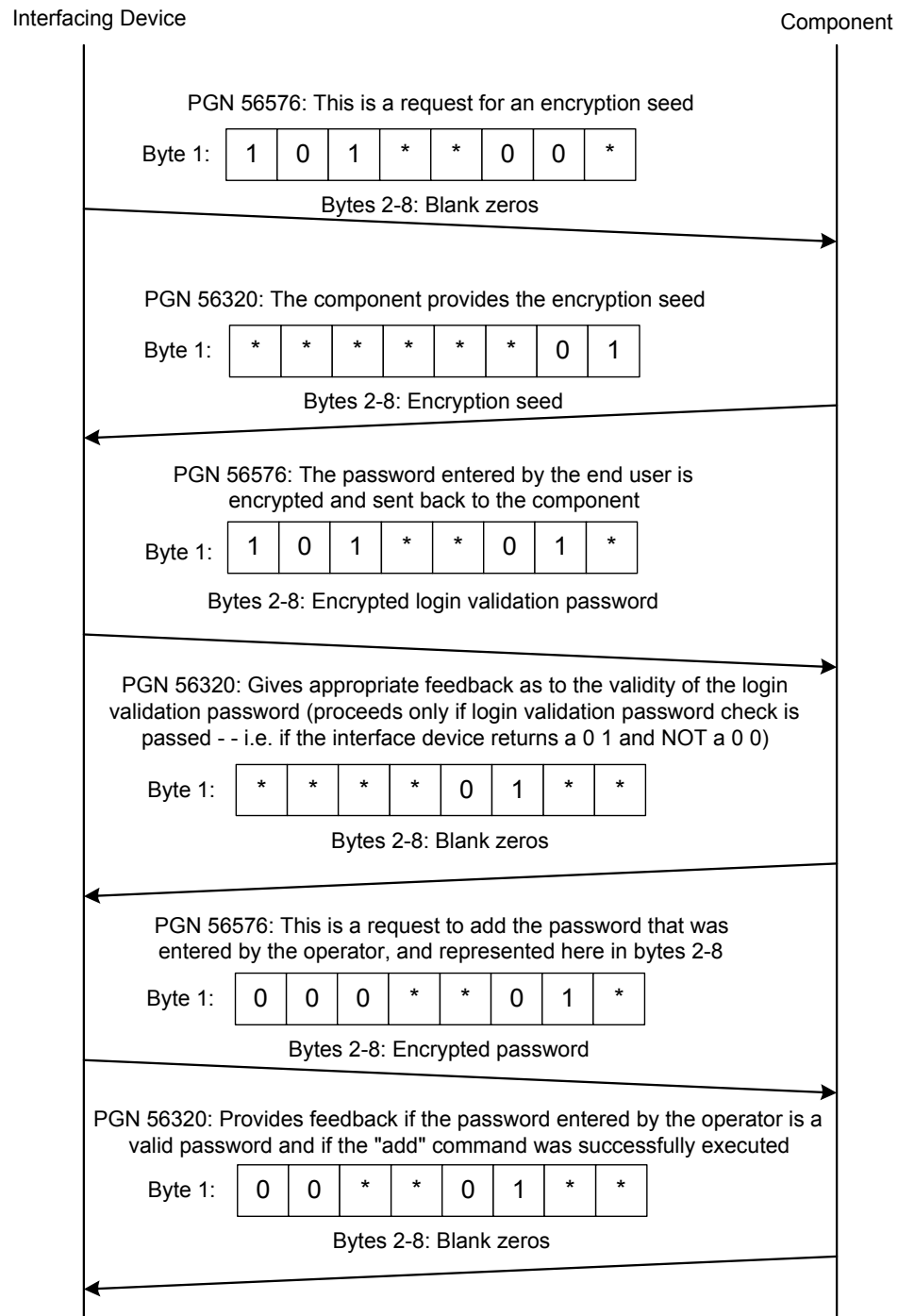

FIGURE PGN56320_A - OPERATOR DESIRES TO ADD A PASSWORD TO THE COMPONENT'S PASSWORD STRUCTURE

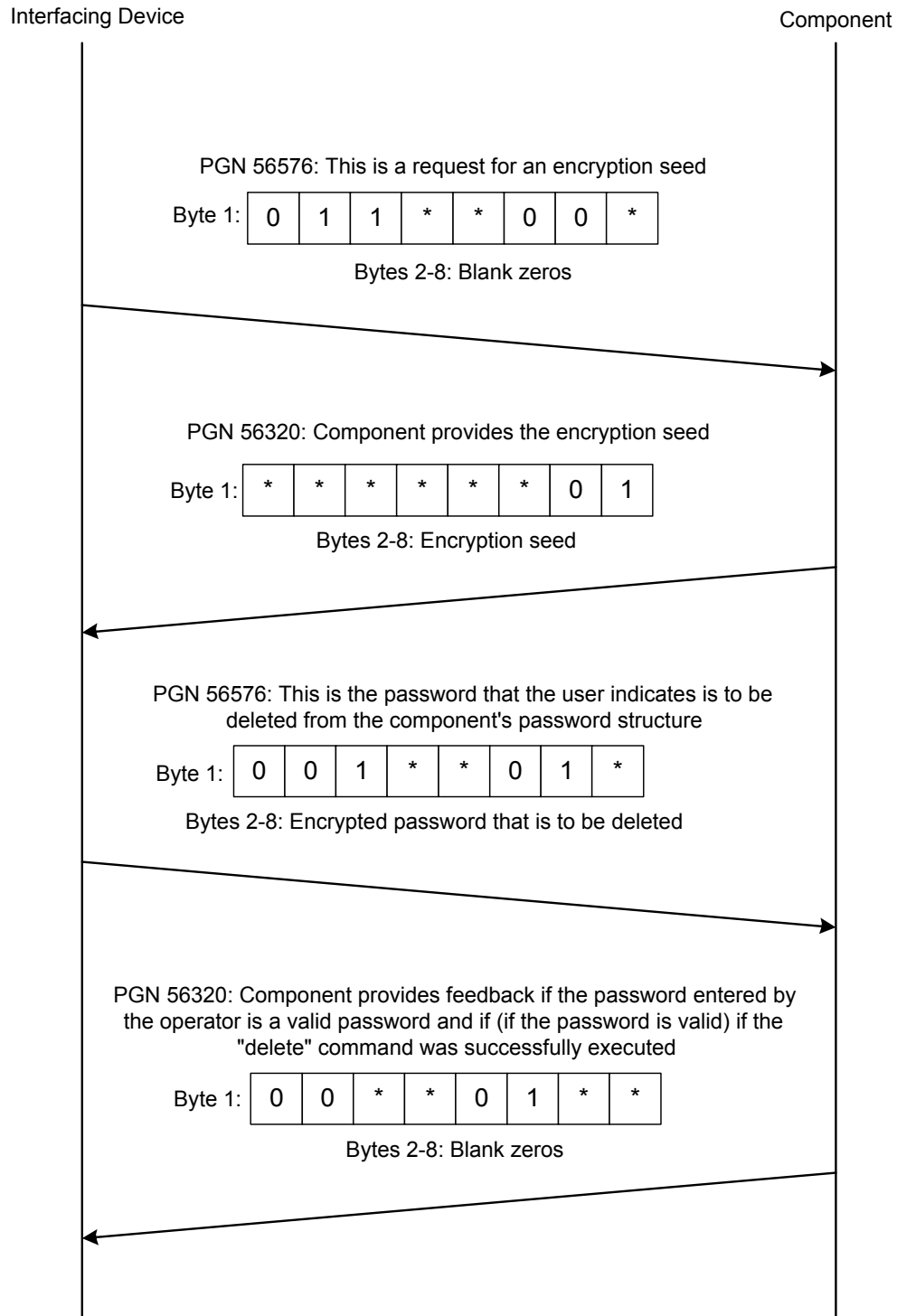

FIGURE PGN56320_B—OPERATOR DESIRES TO DELETE A PASSWORD FROM THE COMPONENT'S PASSWORD STRUCTURE

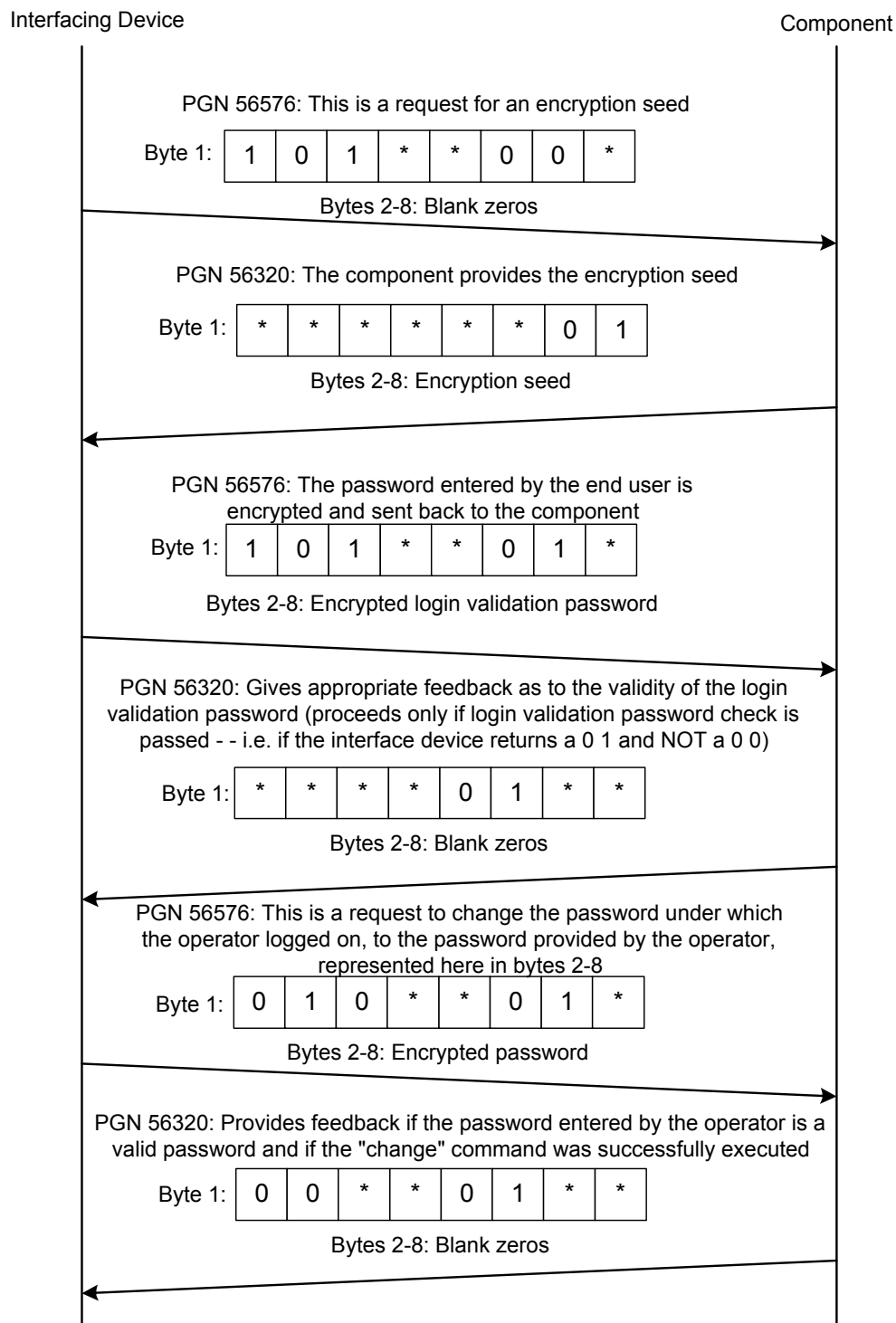

FIGURE PGN56320_C—OPERATOR DESIRES TO CHANGE A PASSWORD WITHIN THE COMPONENT'S PASSWORD STRUCTURE

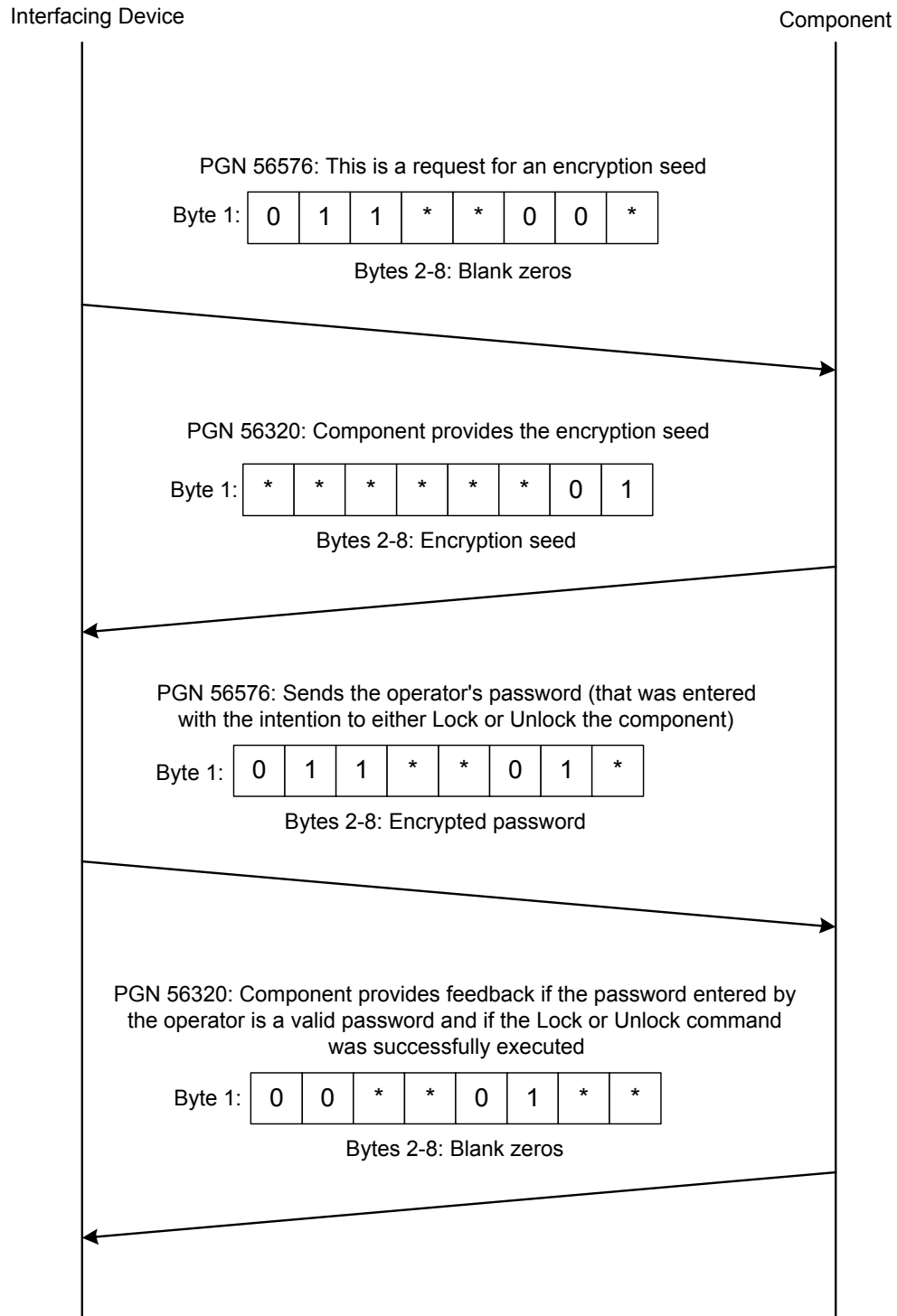

FIGURE PGN56320_D—OPERATOR DESIRES TO LOCK OR UNLOCK THE COMPONENT

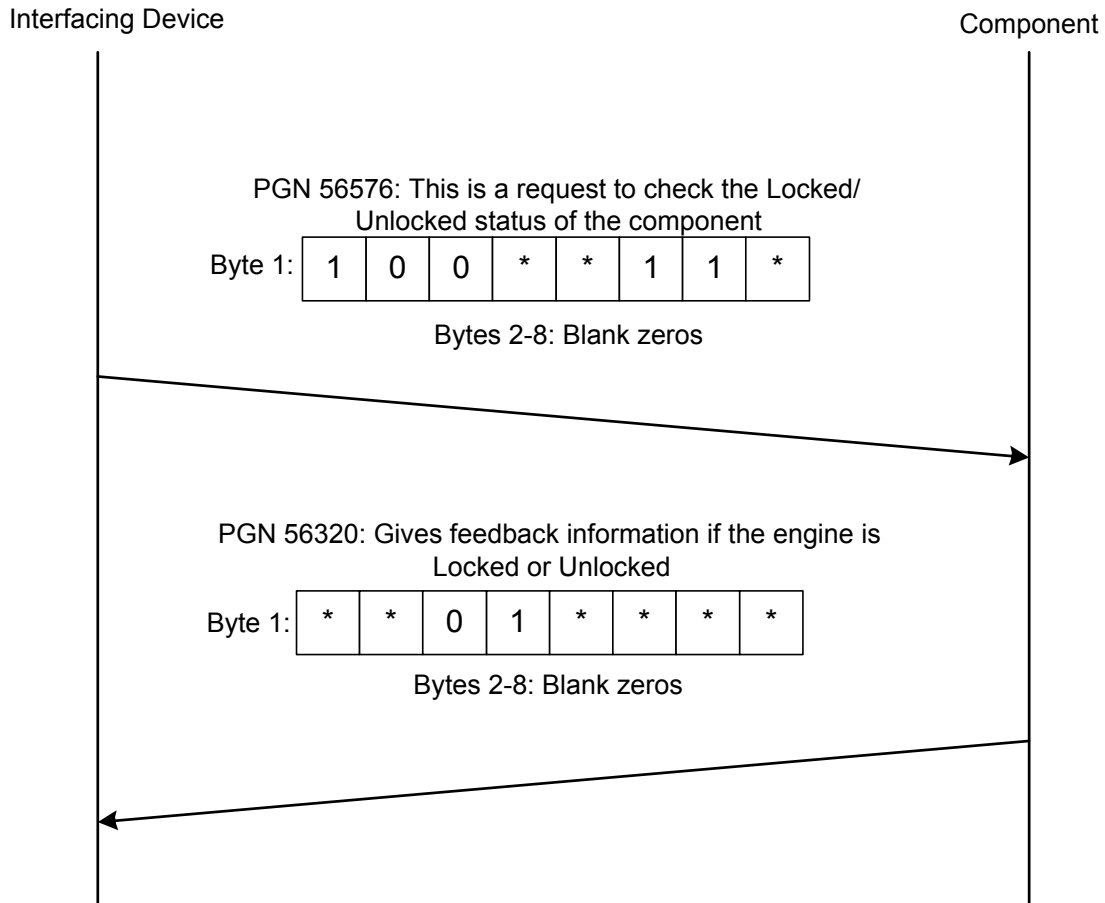

FIGURE PGN56320_E—CHECKING STATUS OF THE COMPONENT

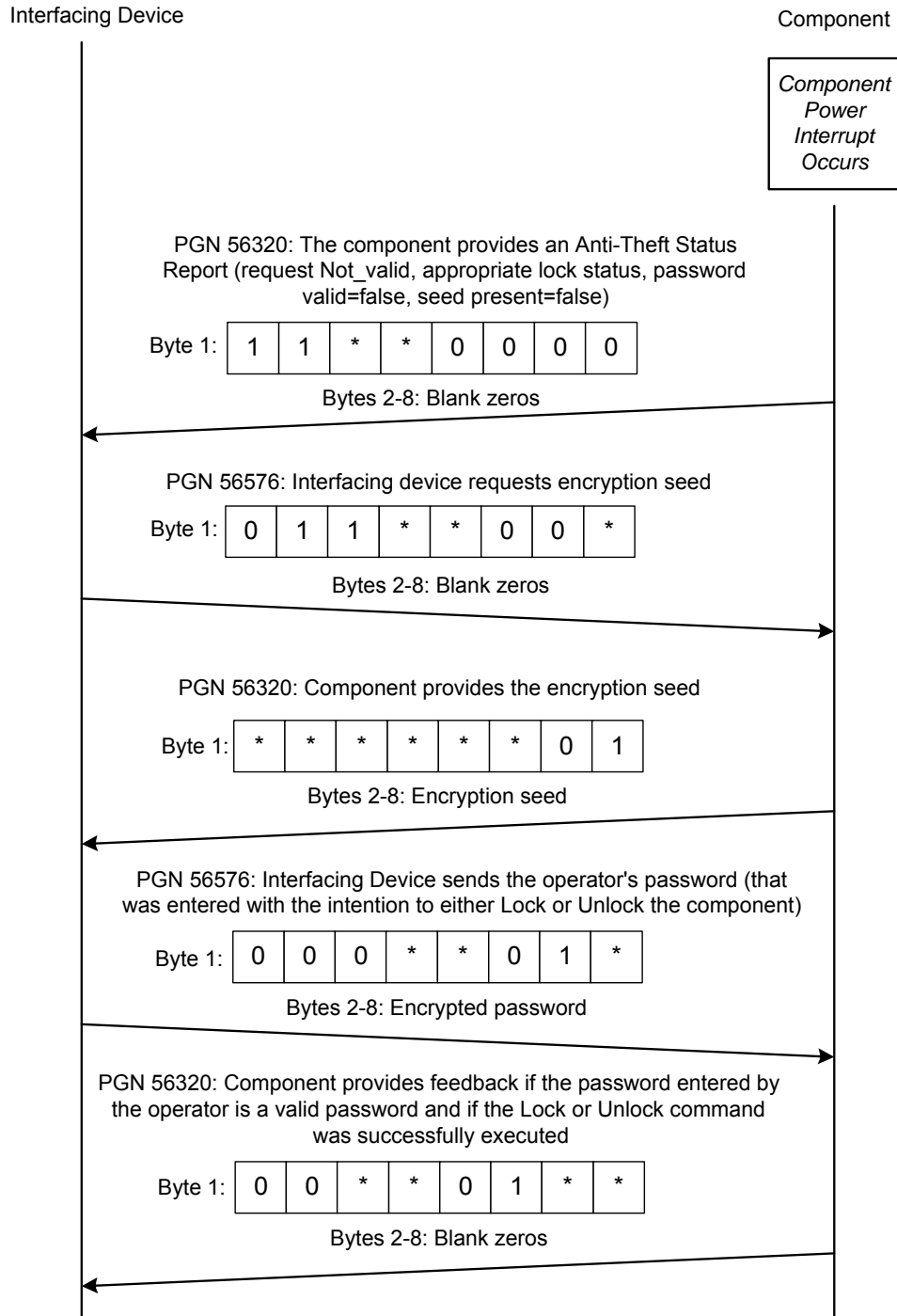

FIGURE PGN56320_F—ABNORMAL COMPONENT POWER INTERRUPTION
(INTERFACING DEVICE POWER IS NOT INTERRUPTED)

PGN 61459 – Slope Sensor Information

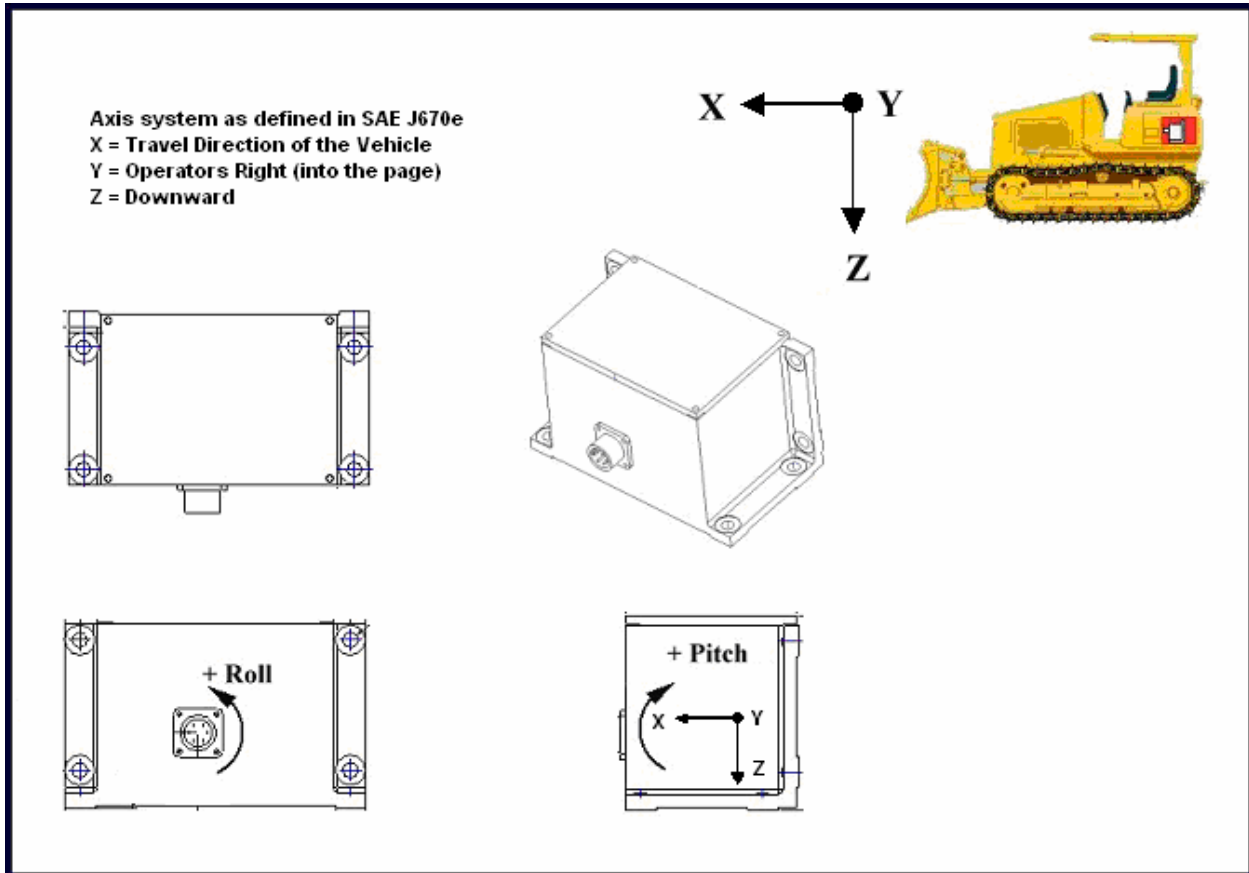

FIGURE PGN61459_A—SLOPE SENSOR ORIENTATIONS

PGN 61466 – Engine Throttle / Fuel Actuator Control Command

Air Handling Systems

FIGURE PGN61466_A – AIR HANDLING SYSTEMS

PGN 64906 – SAE J2012 DTC Display

Conveys basic SAE J2012 DTC information for on-board or service tool displays.

Data byte arrangement: A B₁ B₂ B₃ B₄ B₅ C₁ B_{1x} B_{2x} B_{3x} B_{4x} B_{5x} C_x . . .

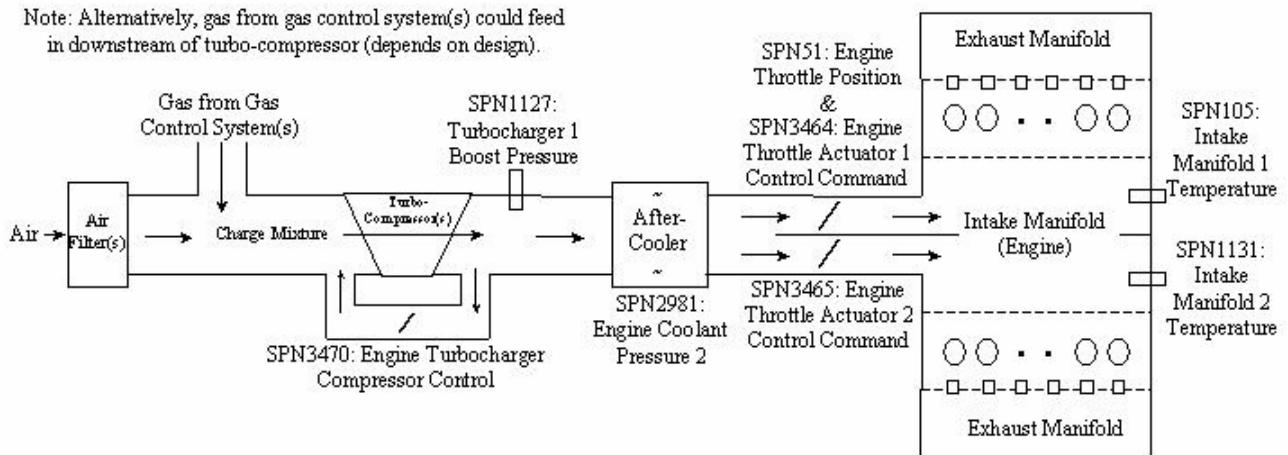
...where:

Data Byte	Definition
A	Number of J2012 DTCs
B _{1x}	1 st Character of J2012 DTC x
B _{2x}	2 nd Character of J2012 DTC x
B _{3x}	3 rd Character of J2012 DTC x
B _{4x}	4 th Character of J2012 DTC x
B _{5x}	5 th Character of J2012 DTC x
C _x	Bit 8: J2012 DTC Status Bits 7-1: J2012 DTC Occurrence Count

If PGN 64906 is requested and a supporting device has no active or inactive J2012 DTCs, PGN 64906 shall be sent as a single frame message with the first data byte (*Number of J2012 DTCs*) set to zero. When two or more J2012 DTCs are indicated, PGN 64906 must be sent via Transport Protocol (See J1939-21).

EXAMPLE – A device conveying (1) an active P1482 with 9 counts and (2) an inactive U0100 with 4 counts would populate the data bytes as follows:

Data Byte:	1	2	3	4	5	6	7	8	9	10	11	12	13
Decimal	2	80	49	52	56	50	137	85	48	49	48	48	4
ASCII:	--	'P'	'1'	'4'	'8'	'2'	--	'U'	'0'	'1'	'0'	'0'	--

PGN 64912 – Advertised Engine Torque Curve

This map conveys the advertised torque curve for the engine, as typically seen on specification sheets available from most engine manufacturers. The collection conditions for the data conveyed are indicated by SPN 3558 – AETC Data Collection Standard.

This map does not contain dynamic elements, and does not change during engine operation. For engines capable of dynamically switching between torque curves or ratings during operation, this map contains values for the highest (most powerful) rating. This map is not intended for use in real time engine control, but merely to indicate what engine rating is installed in the vehicle.

Data points on the curve are in order from left to right, and, at a minimum, must span from the lowest rpm where peak torque can be produced to the high speed governor breakpoint. SPN 3559 – Number of AETC Data Points indicates the number of data points being sent. A minimum of 5 points must be supported, with up to 15 available as needed to properly convey the shape of the torque curve. As illustrated below, speed values need not be evenly incremented.

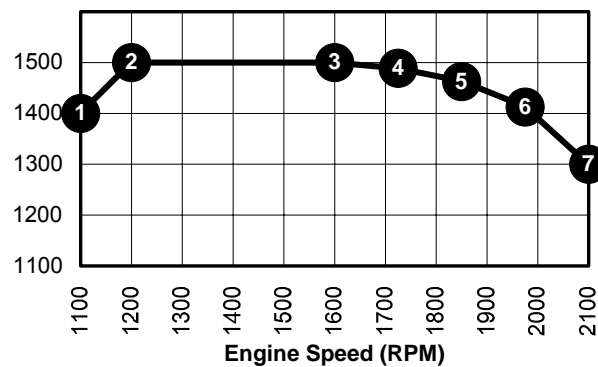

FIGURE PGN64912_A – ADVERTISED ENGINE TORQUE CURVE

PGN 64932 – PTO Drive Engagement

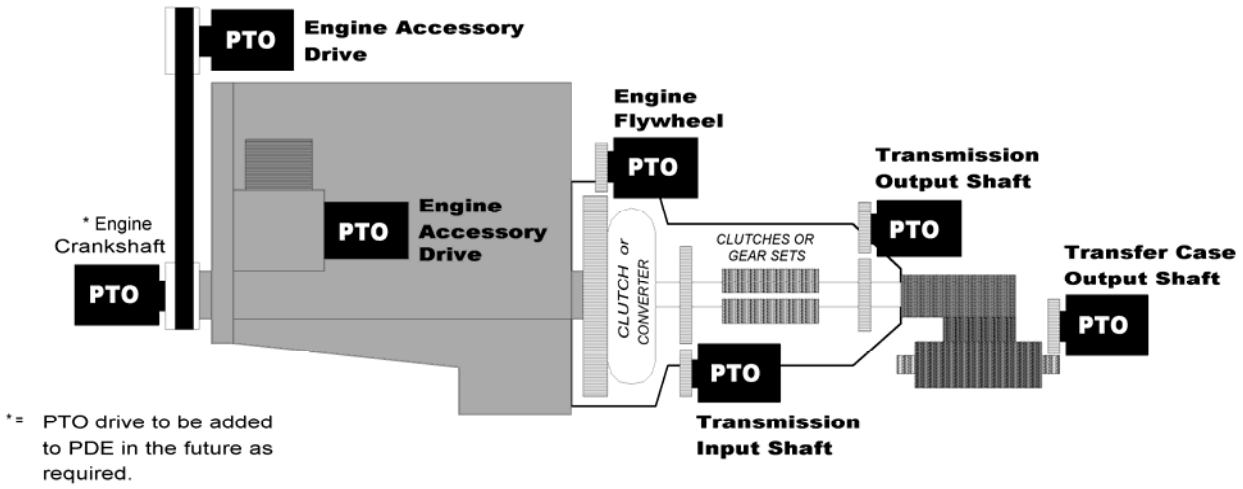

FIGURE PGN64932_A – PTO DRIVE ENGAGEMENT LOCATIONS

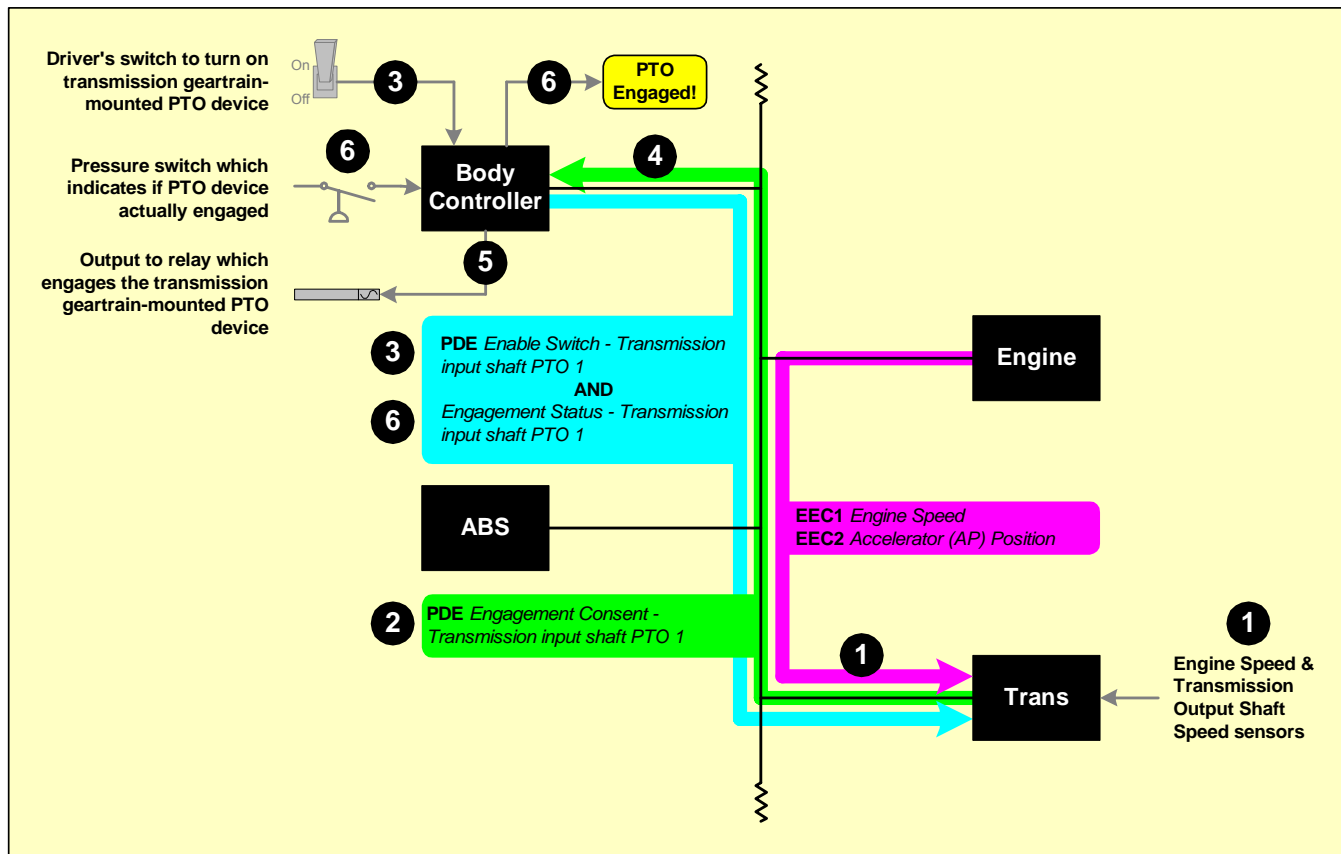

FIGURE PGN64932_B – VEHICLE OEM CONTROLLER INTERFACES WITH ALL PTO WIRING

More ideal from an OEM standpoint, as they no longer need any specialized PTO wiring for different makes of transmissions.

1. The transmission continually monitors the conditions it requires before its PTO drive can be engaged. This may include internal sensors as well as data collected from the network, such as throttle position.
2. Regardless of whether the operator has requested PTO engagement, the 'engagement consent' status is continually broadcast by the transmission.
3. The operator turns on the cab switch to activate the PTO device mounted on the transmission. The Body Controller reflects this switch status in its PDE message broadcast; the transmission or other devices on the network may choose to use this information in their control logic.
4. Among its conditions and inputs required before engaged the PTO drive, the Body Controller checks the 'consent' status broadcast from the transmission.
5. If conditions are acceptable, the Body Controller power the circuit to engage the PTO mounted on the transmission.
6. The Body Controller monitors the progress of the physical PTO engagement, and reflects this in its PDE broadcast so that other on the network may use the information.
7. The Body Controller continues to monitor the transmissions 'consent' broadcast, and disengages the PTO if at any time the transmission rescinds its consent.

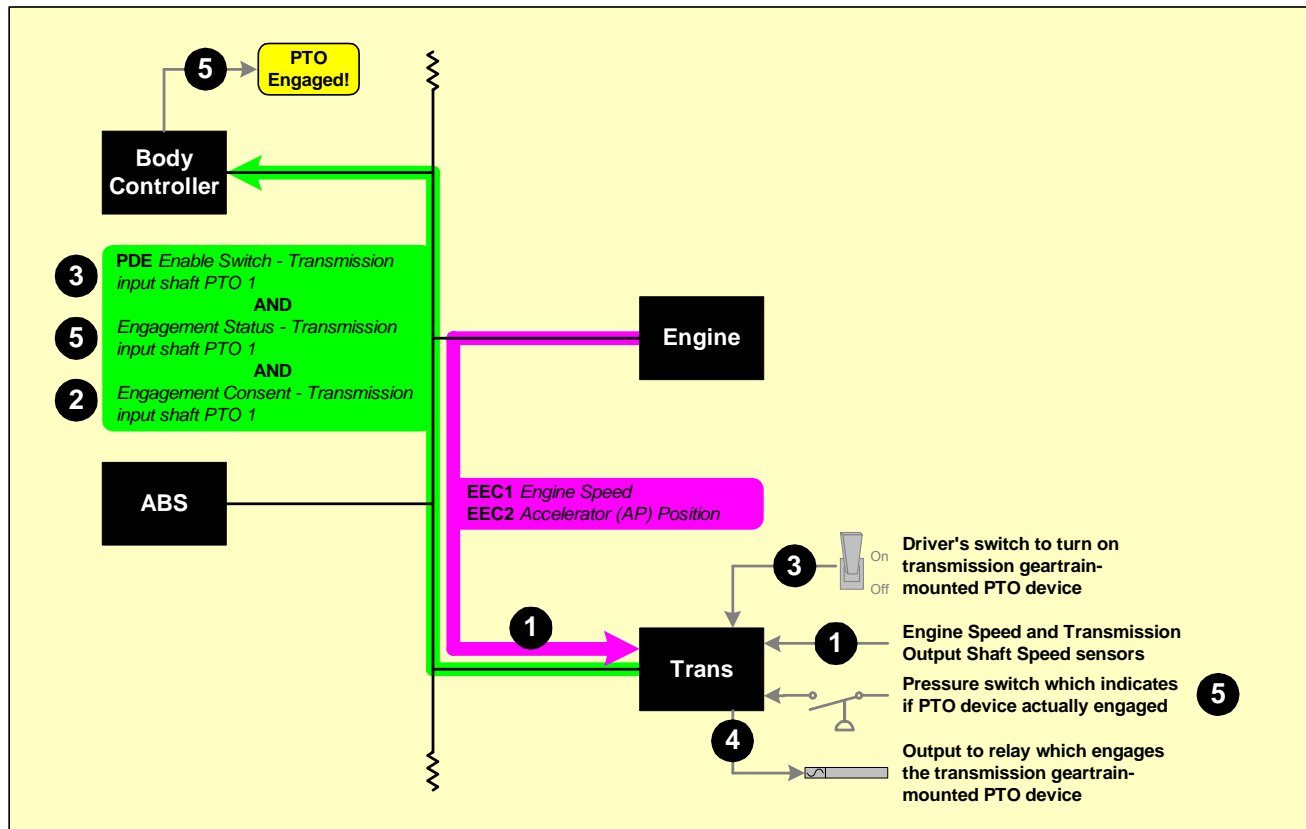

FIGURE PGN64932_C – COMPONENT DRIVING PTO INTERFACES WITH ALL PTO WIRING

This arrangement might be better suited for small OEMs who would rather not deal with figuring out the PTO wiring.

The key point is that the proposed PTO Engagement message structure would adapt to either configuration. Note that the Body Controller broadcasts no new messages; only the transmission sends the PDE message.

1. The transmission continually monitors the conditions it requires before its PTO drive can be engaged. This may include internal sensors as well as data collected from the network, such as throttle position.
2. Regardless of whether the operator has requested PTO engagement, the 'engagement consent' status is continually broadcast by the transmission.
3. The operator turns on the cab switch to activate the PTO device mounted on the transmission. The Transmission Controller reflects this switch status in its PDE message broadcast; the Body Controller or other devices on the network may choose to use this information in their control logic.
4. If conditions are acceptable, the Transmission Controller power the circuit to engage the PTO mounted on the transmission.
5. The Transmission Controller monitors the progress of the physical PTO engagement, and reflects this in its PDE broadcast so that other on the network may use the information.

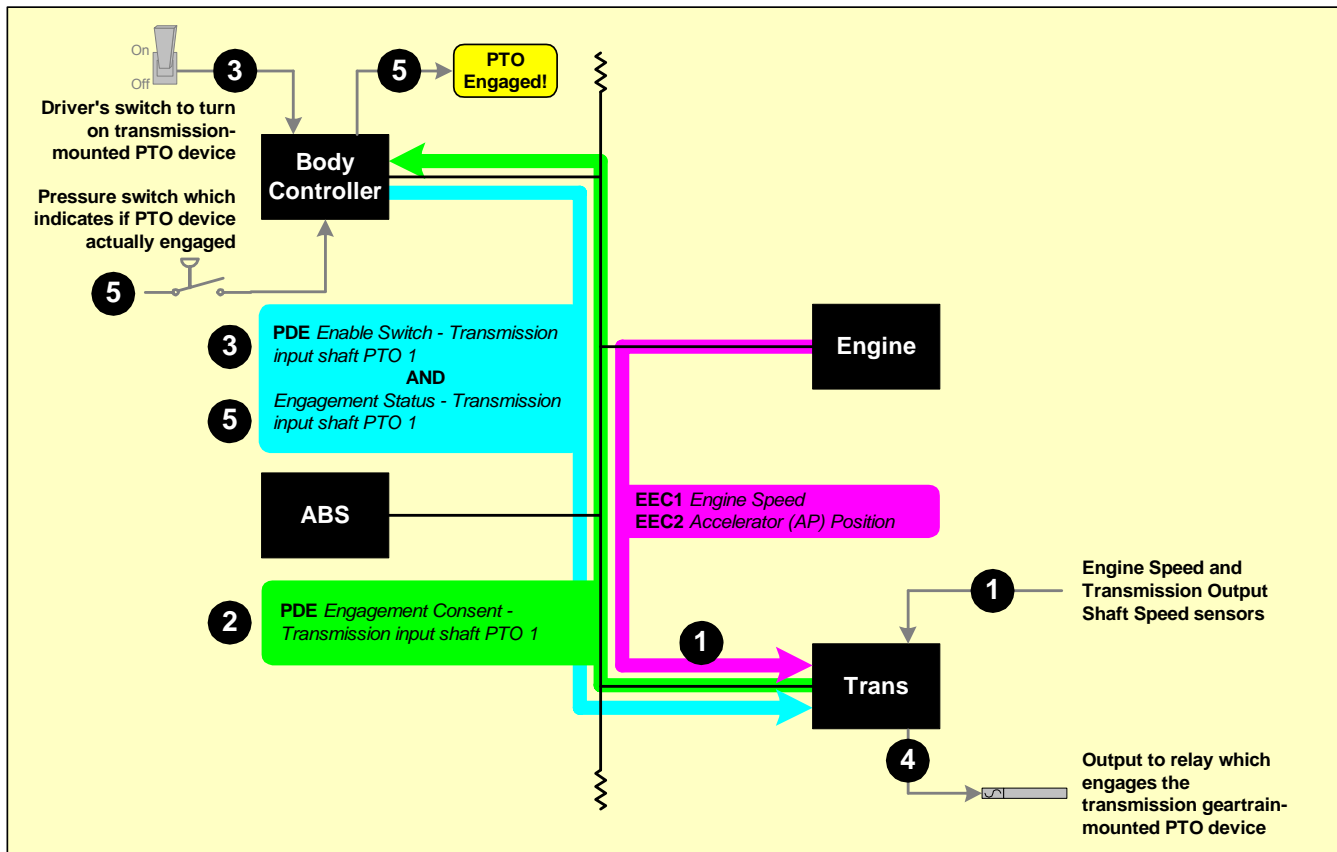

FIGURE PGN64932_D – DISTRIBUTED PTO INTERFACES WIRING

This arrangement is shown to illustrate the flexibility of the PDE messaging.

The various inputs are distributed among two or three controllers that are part of the PTO engagement system.

1. The transmission continually monitors the conditions it requires before its PTO drive can be engaged. This may include internal sensors as well as data collected from the network, such as throttle position.
2. Regardless of whether the operator has requested PTO engagement, the 'engagement consent' status is continually broadcast by the transmission.
3. The operator turns on the cab switch to activate the PTO device mounted on the transmission. The Body Controller reflects this switch status in its PDE message broadcast; the Transmission Controller receives this input.
4. If conditions are acceptable, the Transmission Controller power the circuit to engage the PTO mounted on the transmission.
5. The Body Controller monitors the progress of the physical PTO engagement, and reflects this in its PDE broadcast so that other on the network may use the information.

PGN 64938 – Engine Fluid, Level and Pressure 4

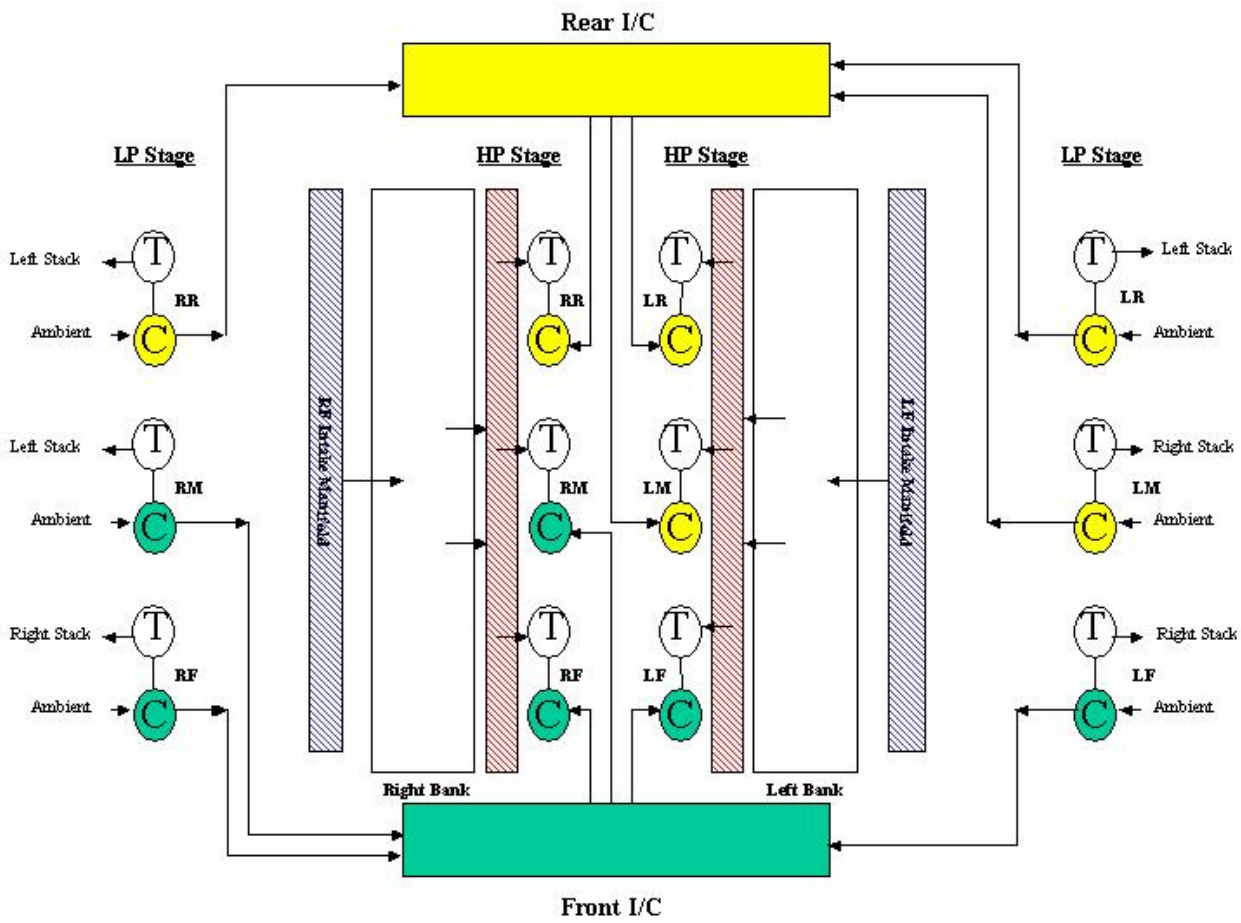
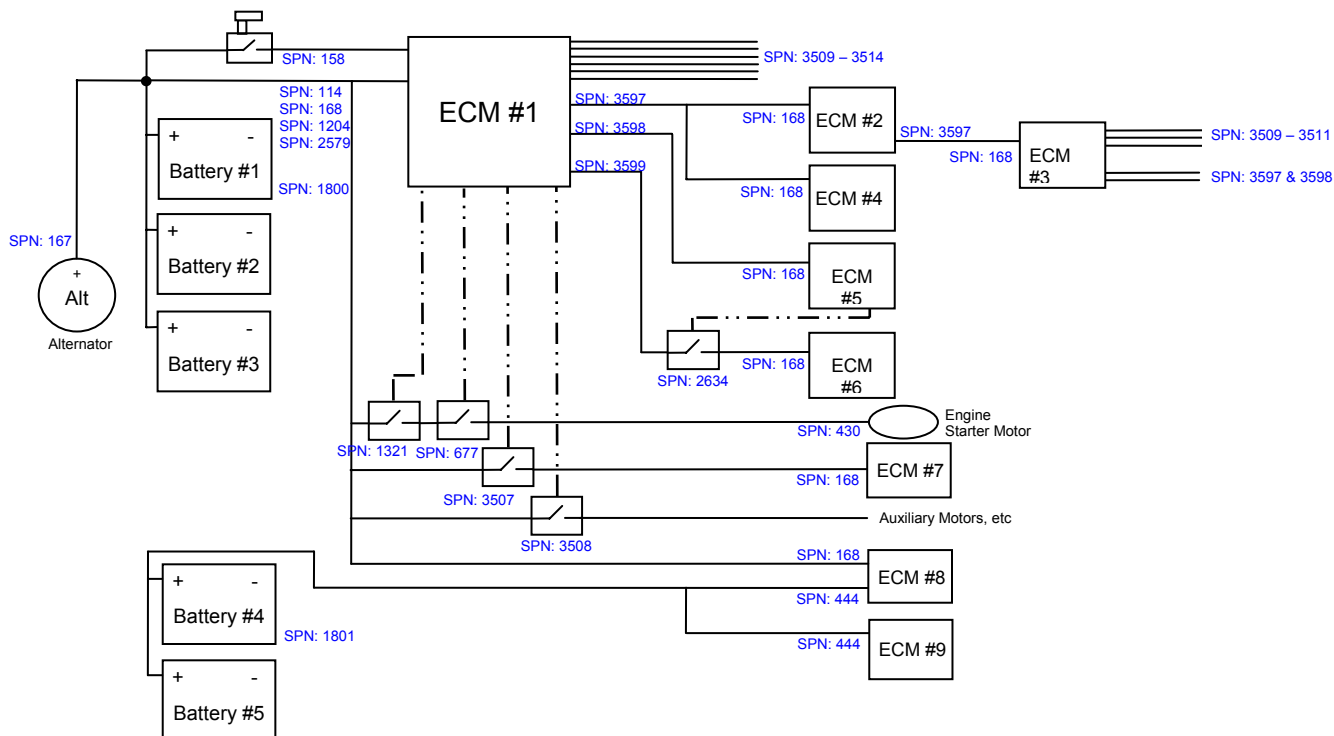

FIGURE PGN64938_A – ENGINE CHARGE AIR COOLER PRESSURES

PGN 65104 – Battery Information



Note: The ECMs shown in this diagram could represent an ECM, or any intelligent device that is capable of diagnostics.

FIGURE PGN65104_A – BATTERY INFORMATION

SPN	SPN Name	SPN	SPN Name
114	Net Battery Current	2579	Net Battery Current (High Range/Resolution)
115	Alternator Current	2634	Power Relay
158	Keyswitch Battery Potential	3507	TECU ECU PWR Relay
167	Charging System Potential (Voltage)	3508	TECU PWR Relay
168	Battery Potential / Power Input 1	3509	Sensor Supply 1
430	Engine Starter Solenoid Voltage	3510	Sensor Supply 2
444	Battery Potential / Power Input 2	3511	Sensor Supply 3
677	Engine Starter Motor Relay	3512	Sensor Supply 4
1204	Electrical Load	3513	Sensor Supply 5
1321	Engine Starter Solenoid Lockout Relay Driver Circuit	3514	Sensor Supply 6
1795	Alternator Current (High Range/Resolution)	3597	ECU Power Output 1
1800	Battery 1 Temperature	3598	ECU Power Output 2
1801	Battery 2 Temperature		

FIGURE PGN65104_B – BATTERY INFORMATION LEGEND

PGN 65135 – Adaptive Cruise Control

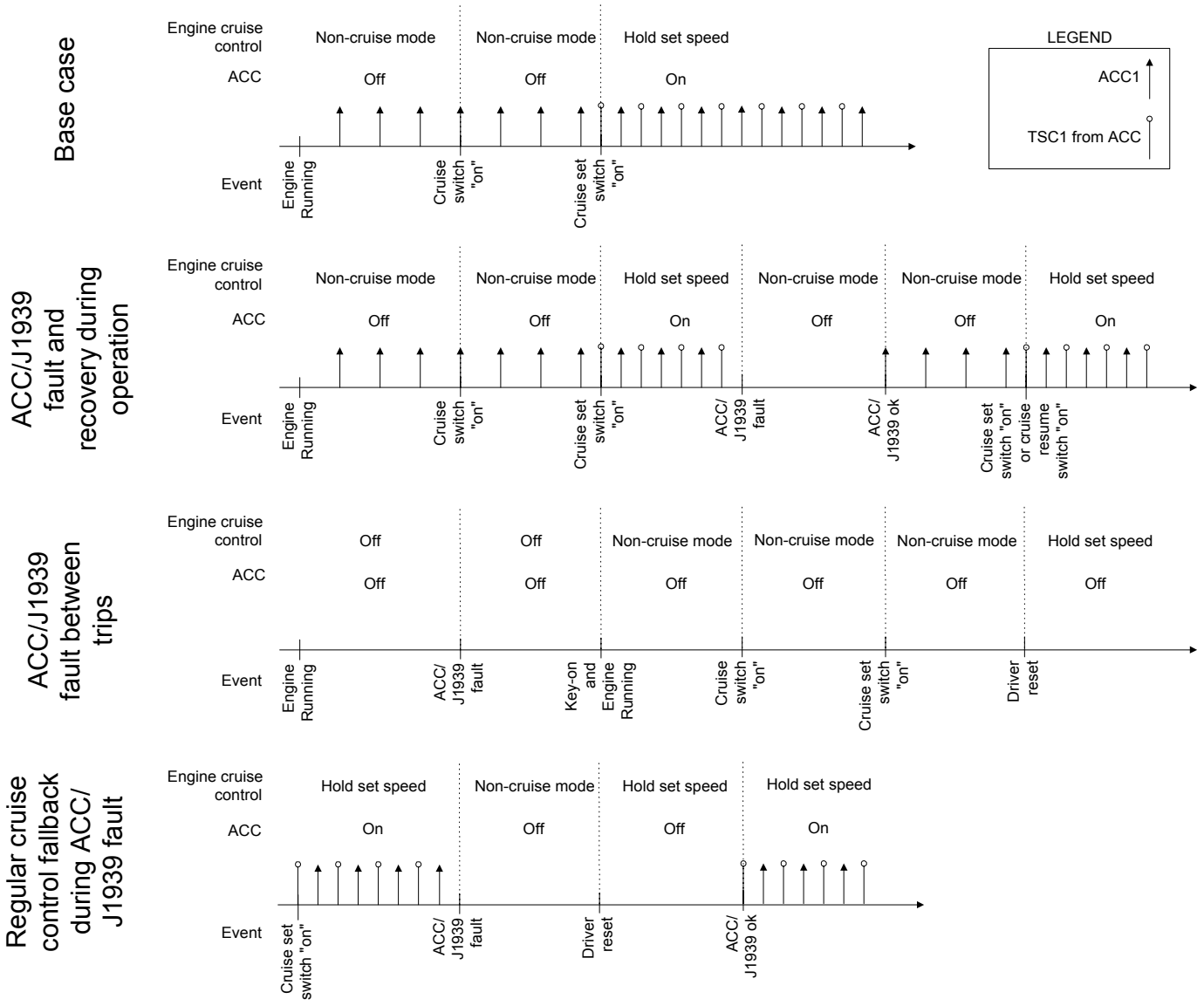

FIGURE PGN65135_A – ADAPTIVE CRUISE CONTROL TIMING DIAGRAM

PGN 65163 – Gaseous Fuel Pressure

Gas Supply and Control Systems



FIGURE PGN65163_A – GAS SUPPLY AND CONTROL SYSTEMS

PGN 65249 – Retarder Information

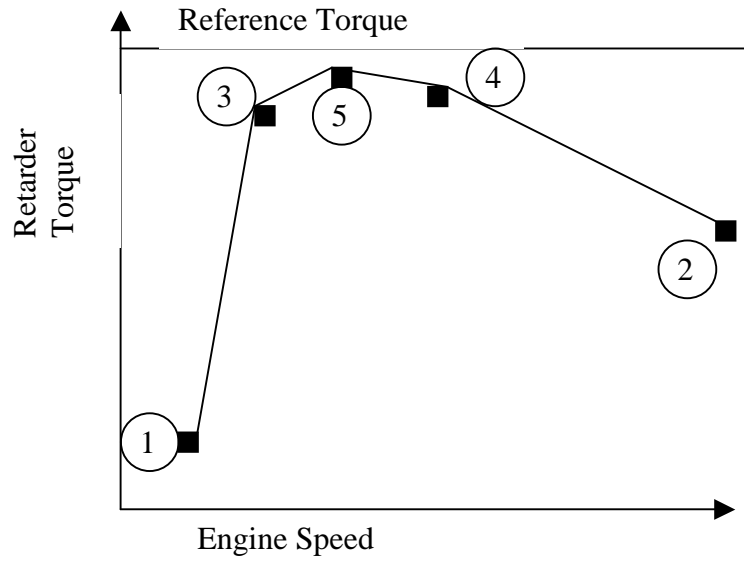

FIGURE PGN65249_A—TYPICAL HYDRAULIC RETARDER TORQUE CURVE

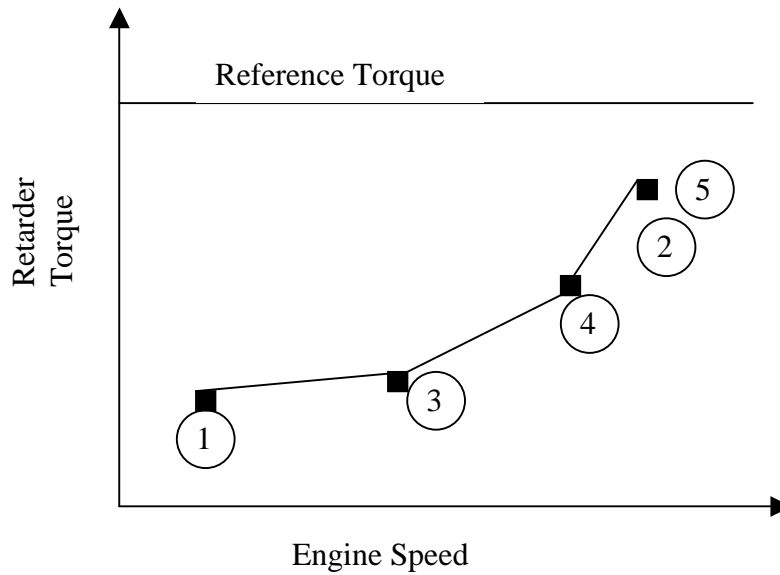

FIGURE PGN65249_B—TYPICAL ENGINE COMPRESSION BRAKE TORQUE CURVE

PGN 65251 – Engine Configuration 1**TABLE PGN65251_A—ENGINE CONFIGURATION CHARACTERISTIC MODES**

Mode	Torque/Speed Point 2	Governor Gain KP	High Idle Speed
1	Available	Not available	Available
2	Not Available	Available	Available
3	Available	Available	Not available

The following points are shown in Figures PGN65251_A, PGN65251_B, and PGN65251_C.

Point 1 (required): Torque/speed point at idle

Point 2 (required): Mode 1 & 3: Torque/speed point at which the high speed governor becomes active

Mode 2: Normal torque/speed point

Point 3,4,5 (required): Torque/speed points between points 1 and 2 to permit linear interpolation over the entire torque range. It is required that one of these points indicate the peak torque point for the current engine torque map.

Point 6 (mode dependent): Mode 1 & 2: High idle speed (torque = 0)

Mode 3: Not available (point is defined by the endspeed governor where torque = 0)

Point 7 (optional): Maximum momentary engine override speed (torque = 0)

Reference engine torque: Engine torque in Nm.

This parameter is the reference value of 100% for all defined indicated engine torque parameters. It is only defined once and doesn't change if a different engine torque map becomes valid.

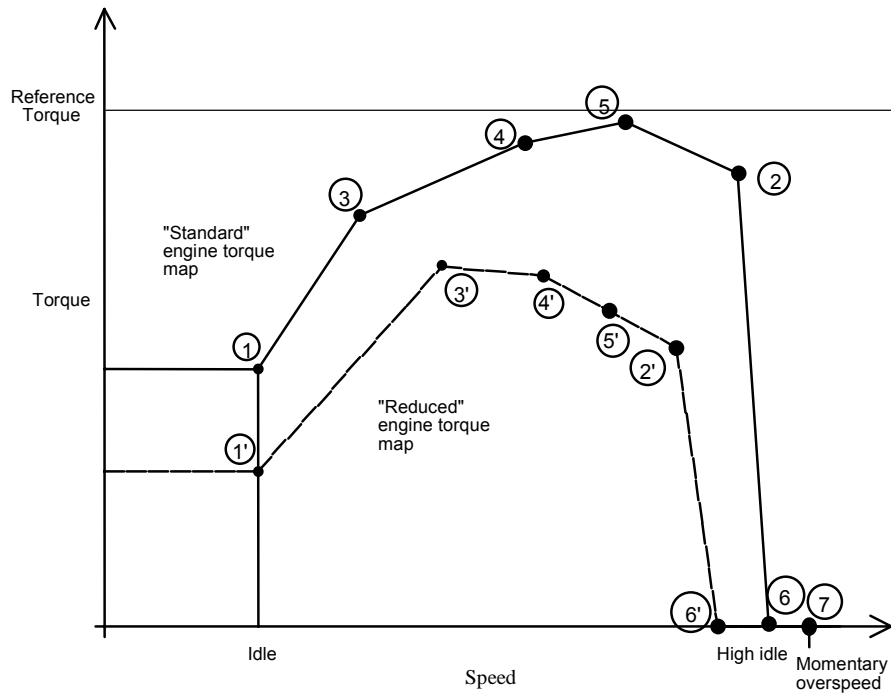

FIGURE PGN65251_A—ENGINE CONFIGURATION MAP-MODE 1

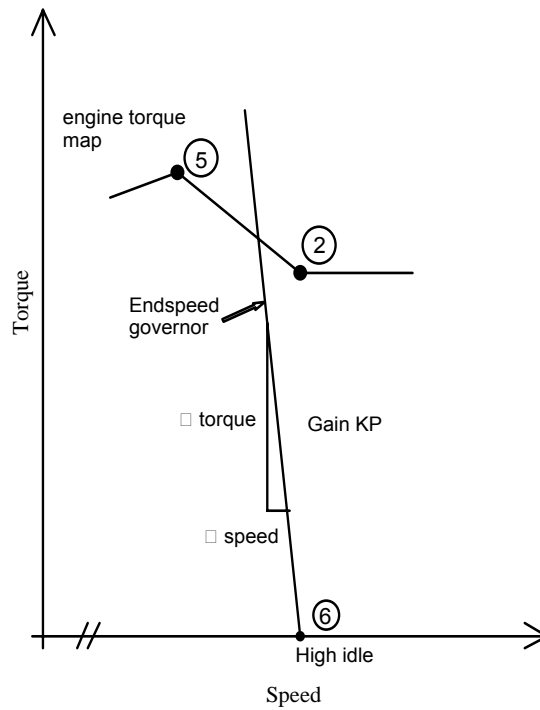

FIGURE PGN65251_B—ENGINE CONFIGURATION MAP-MODE 2

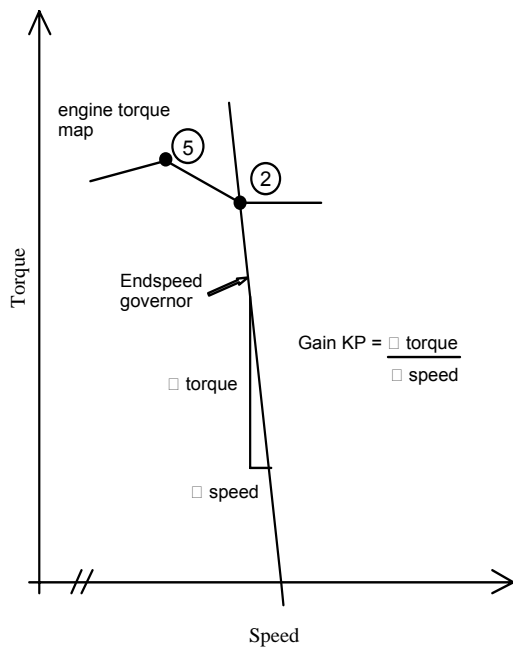

FIGURE PGN65251_C—ENGINE CONFIGURATION MAP-MODE 3