

SUZUKI

FZ50

SERVICE MANUAL



FOREWORD

This service manual has been specially prepared to provide all the necessary information for the proper maintenance and repair of the FZ50. The contents have been simplified so that FZ50 owners, as well as experienced mechanics, may fully utilize this manual.

The FZ50 is a new type of motorcycle that has many special features such as:

- 1) Easy to ride operation*
- 2) Easy, smooth handling due to light weight and size*
- 3) Simple to maintain and service*
- 4) Technical features such as PEI ignition, automatic transmission and clutch*

The FZ50 fits the needs of a wide variety of motorcycle users. Those who will be servicing this motorcycle should carefully review this manual before performing any repairs or services.

SUZUKI MOTOR CORPORATION

*Motorcycle Technical
Service Department*

All specifications and construction details contained in this manual were correct at time of issue. Suzuki Motor Co. reserves the right to make changes without notice at any time.

Quoting, copying or otherwise using any part of this manual without explicit authorization from Suzuki Motor Corporation is not permitted as all rights to the publication are reserved under copyright law.

GROUP INDEX

GENERAL INFORMATION	1
INSPECTION AND ADJUSTMENT	2
SERVICING PROCEDURE	3
SERVICING INFORMATION	4
FZ50“T” AND FZ50“X”	5
FZ50“Z”	6
FZ50“D”	7
FZ50“G”	8
FZ50“H”	9
FZ50“K”	10
FZ50“L”	11

GENERAL INFORMATION

CONTENTS

MODEL IDENTIFICATION	1-2
SPECIFICATIONS	1-3
FUEL AND OIL RECOMMENDATION	1-5
GENERAL NOTES AND PRECAUTIONS.....	1-6
TECHNICAL FEATURES	1-7

MODEL IDENTIFICATION

RIGHT SIDE VIEW

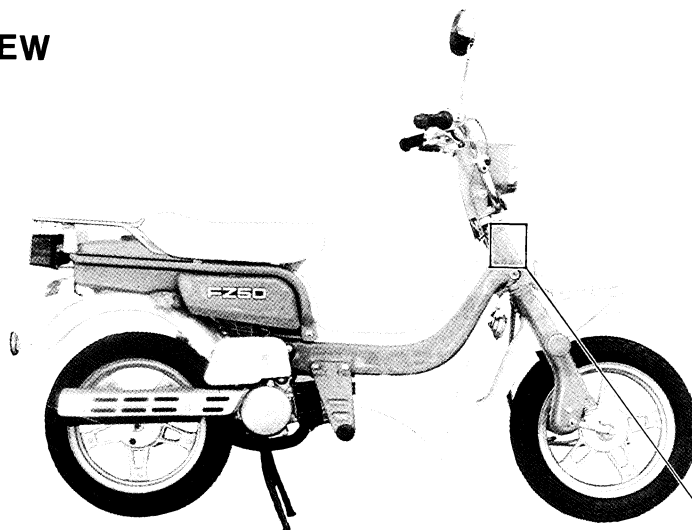

FRAME NUMBER

The frame serial number is stamped on the right side of the steering head pipe.

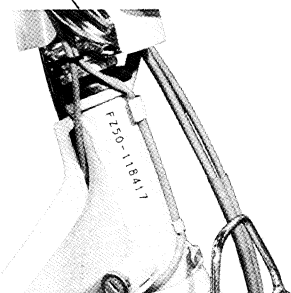

LEFT SIDE VIEW

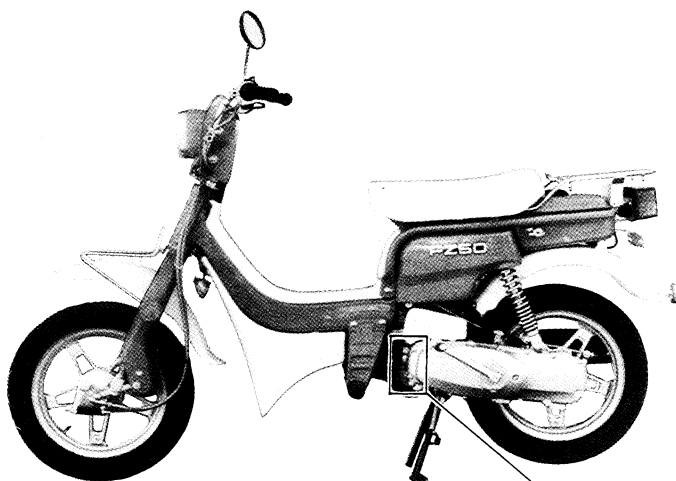

ENGINE NUMBER

The engine serial number is located on the left side crankcase.

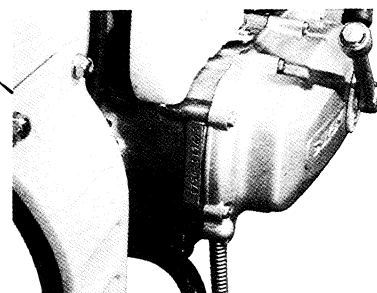

These numbers are required especially for registering the machine and ordering the spare parts.

SPECIFICATIONS

DIMENSIONS AND WEIGHT

Overall length	1 650 mm (65.0 in)
Overall width	665 mm (26.2 in)
Overall height	990 mm (39.0 in)
Wheelbase	1 120 mm (44.1 in)
Ground clearance	120 mm (4.7 in)
Dry mass (weight)	59 kg (130 lbs)

ENGINE

Type	Two-stroke, air cooled
Intake system	Reed valve
Number of cylinder	1
Bore	41.0 mm (1.614 in)
Stroke	37.4 mm (1.472 in)
Piston displacement	49 cm ³ (3.0 cu.in)
Corrected compression ratio	6.1 : 1
Carburetor	MIKUNI VM14SH, single
Air cleaner	Polyurethane foam element
Starter system	Primary kick
Lubrication system	SUZUKI "CCI"

TRANSMISSION

Clutch	Wet shoe, automatic, centrifugal type
Transmission	2-speed
Gearshift pattern	Automatic type
Primary reduction	1.000
Final reduction	8.696
	(chain)
	2.384 (31/13)
	(gear)
	3.647 (62/17)
Gear ratios, Low	2.137 (62/29)
	2nd
	1.421 (54/38)
Drive chain	DAIDO D.I.D. 270H, 64 links

CHASSIS

Front suspension	Bottom link oil dampened
Rear suspension	Swinging arm
Steering angle	45° (right & left)
Caster	63° 00''
Trail	81 mm (3.19 in)
Turning radius	1.7 m (5.6 ft)
Front brake	Internal expanding
Rear brake	Internal expanding
Front tire size	3.00-12-4PR
Rear tire size	3.00-12-4PR
Front tire pressure	125 kPa (1.25 kg/cm ² , 18 psi) (Normal solo riding)
Rear tire pressure	150 kPa (1.50 kg/cm ² , 21 psi) (Normal solo riding)

ELECTRICAL

Ignition type	SUZUKI "PEI"
Ignition timing	20° B.T.D.C. at 4 000 r/min
Spark plug	NGK BP4HA or NIPPON DENSO W14FP-UL
Battery	6V 14.4 kC (4 Ah)/10 HR
Generator	Flywheel magneto
Fuse	10A
Headlight	6V 20/20W
Tail/Brake light	6V 5.3/17W (3/21 cp)
High beam indicator light	6V 1.7W

CAPACITIES

Fuel tank including reserve reserve	4.5 L (1.2/1.0 US/Imp gal) 0.2 L (0.2/0.2 US/Imp qt)
Engine oil tank	1.2 L (1.27/1.06 US/Imp qt)
Transmission oil	800 ml (0.85/0.70 US/Imp qt)

* These specifications are subject to change without notice.

FUEL AND OIL RECOMMENDATION

Be sure to use the specified fuel and oils. The following are the specifications:

FUEL

Gasoline used should be unleaded or low-lead where they are available.

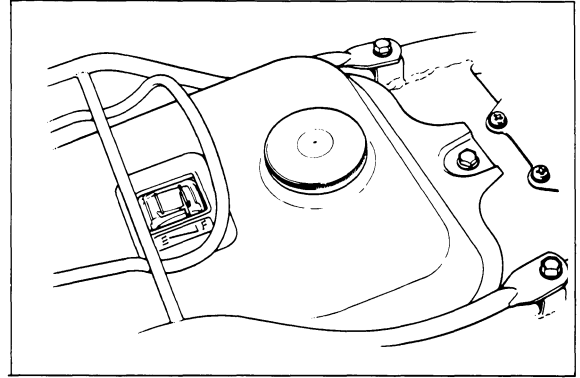

ENGINE OIL

For the SUZUKI CCI system, use of SUZUKI CCI SUPER 2 OIL is highly recommended, but if it is not available, a good quality two-stroke oil (non-diluent type) should be used.

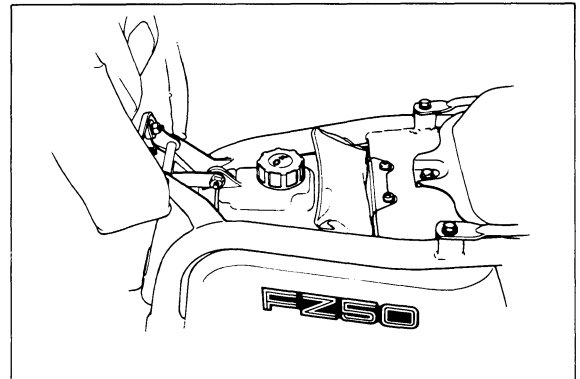

TRANSMISSION OIL

Use a good quality SAE 20W/40 multi-grade motor oil.

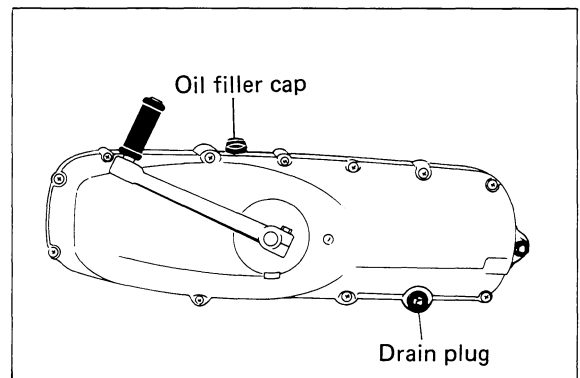

GENERAL NOTES AND PRECAUTIONS

Observe the following items without fail when disassembling and reassembling motorcycles.



- Be sure to replace packings, gaskets, O rings, circlips and cotter pins with new ones.
- Tighten bolts and nuts from the ones of larger diameter to those of smaller diameter, and from inside to out-side diagonally, with specified tightening torque.
- Use special tools where specified.
- Use specified genuine parts and oils.
- When 2 persons perform work in cooperation, pay attention to the safety of each other.
- After the reassembly, check parts for tightening condition and operation.
- Treat gasoline, which is extremely flammable and highly explosive, with greatest care. Never use gasoline as cleaning solvent.

Warning, caution and note are included in this manual occasionally, describing the following contents.

- WARNING** When personal safety of the rider is involved, disregard of the information could result in his injury.
- CAUTION** For the protection of the motorcycle, the instruction or rule must be strictly adhered to.
- NOTE** Advice calculated to facilitate the use of the motorcycle is given under this heading.

SYMBOLS

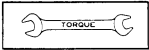
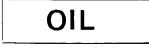
The symbols used in this manual are as follows.

-  : Tightening torque
-  : Oil
-  : Grease

TECHNICAL FEATURES

DESCRIPTION

The FZ50 has a 49 cm³ (49 cc), 2-cycle engine with a reed valve. The simple construction and rational design of the engine has minimized the number of inspection items, thus allowing easy inspection and almost maintenance-free operation. This provides a unique motorcycle, with a long enjoyable life, free from troubles.

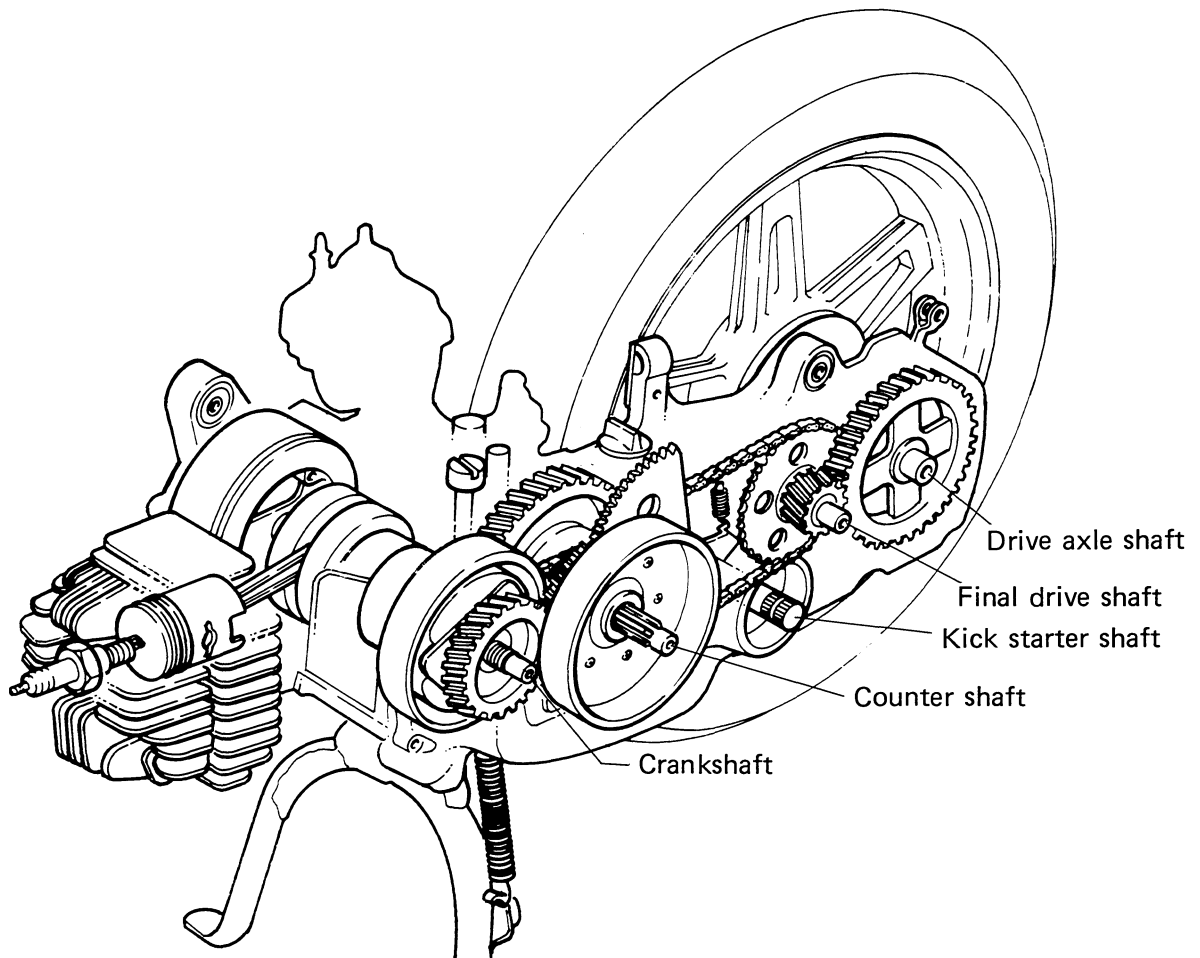

REED VALVE

A reed valve is used in the intake system. The reed valve has thin, flexible steel pieces and are fitted into the top of the crankcase. As the piston moves up and down, the pressure in the crankcase alternately changes to negative and positive, thus causing the reed valve to open and close. The reed valve timing and opening vary depending on the engine speed and throttle opening. In other words, it can be said that the intake timing is ideally matched to the operating condition of the engine.

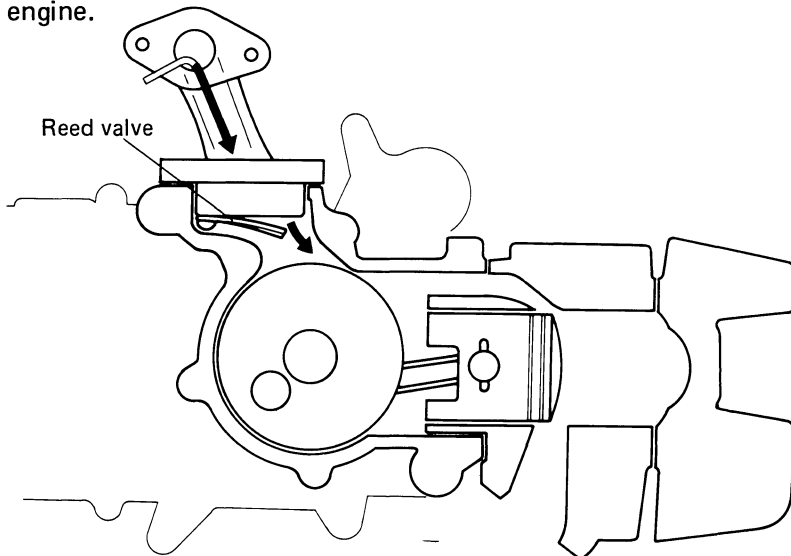

ENGINE LUBRICATION

Engine oil is supplied by means of an oil pump which is driven by the crankshaft through the oil pump driven shaft and oil pump drive gear mounted on the crankshaft. The supply of the oil is controlled by the oil pump cable (interlocked with the throttle cable), and thus an optimum amount of oil is discharged from the pump according to the engine speed.

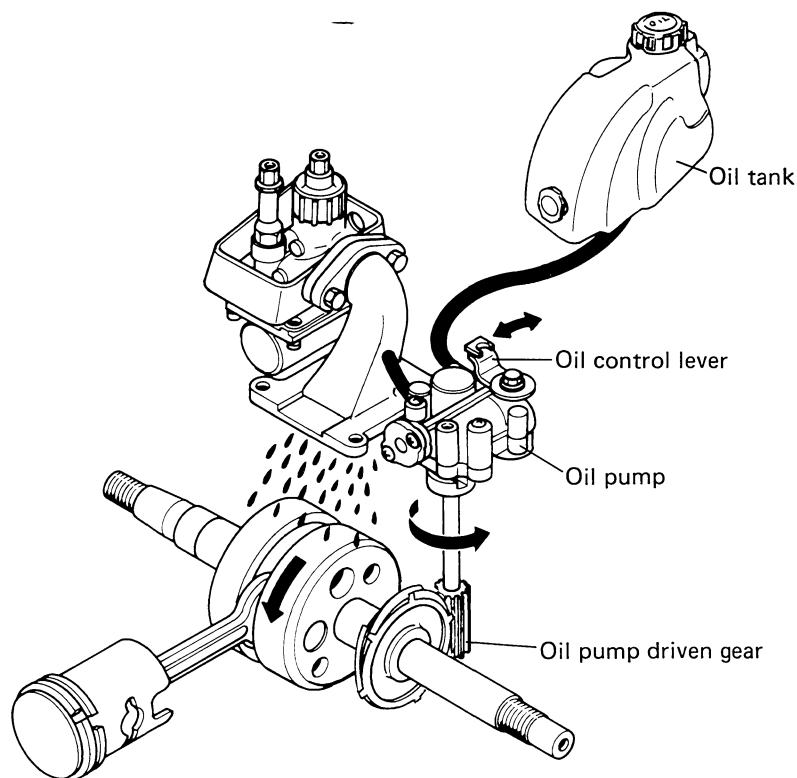

PISTON AND PISTON RING

Both 1st and 2nd piston rings are of keystone type, and an expander ring is with the 2nd ring. The keystone ring is less sticking and has excellent durability. The expander ring absorbs the noise generated by the piston sliding against the cylinder wall by means of its spring tension, thus reducing overall noise.

2nd ring

Parkerized for better "wear-in"

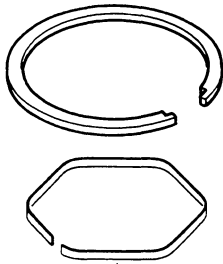

1st ring

Chrome-plated for better durability

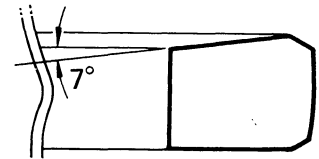
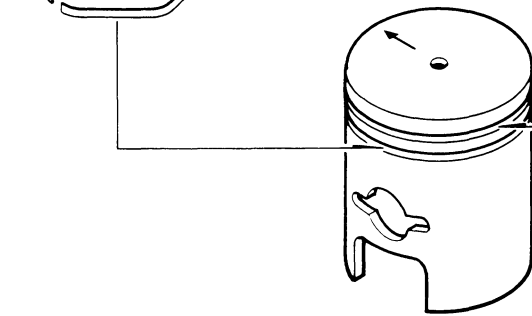
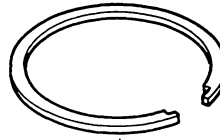

Sectional form of piston ring
Both 1st and 2nd rings are sloped at the top side.

CLUTCH

Automatic centrifugal shoe type clutches are secured to the crankshaft and counter shaft. These clutches have simple construction. When the clutch drive shoes, which are thrown apart by centrifugal force varying with the crankshaft speed, come in contact with the clutch driven wheel, engine power is transmitted to the counter shaft. When the engine speed falls, the centrifugal force decreases and the drive shoes come close together, thus separating from the driven wheel. This eliminates the flow of engine power.

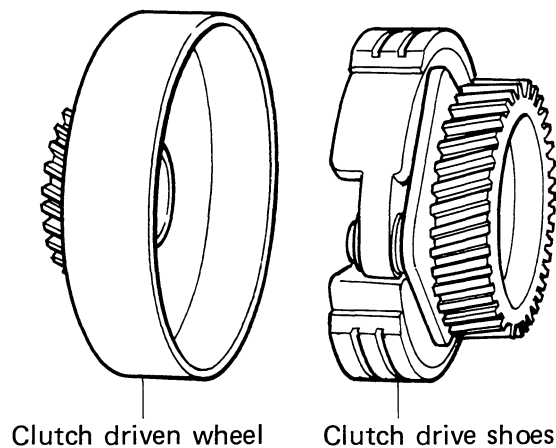

Clutch driven wheel

Clutch drive shoes

POWER TRANSMISSION

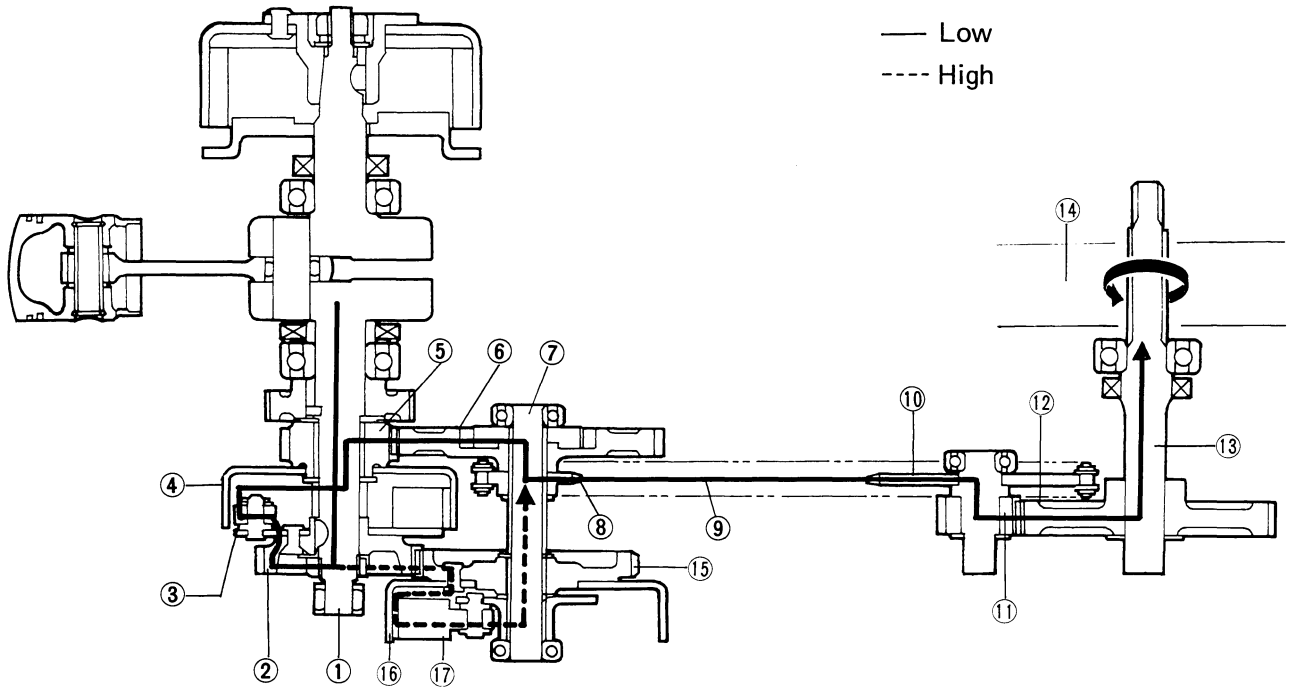

LOW

1. Crankshaft
2. 2nd drive gear
3. Clutch drive shoes
4. Clutch No. 1
5. 1st drive gear
6. 1st driven gear
7. Counter shaft
8. Drive sprocket
9. Drive chain
10. Driven sprocket
11. Final drive gear
12. Final driven gear
13. Drive axle shaft
14. Rear wheel

HIGH

15. 2nd driven gear
16. Clutch No. 2
17. Clutch drive shoes

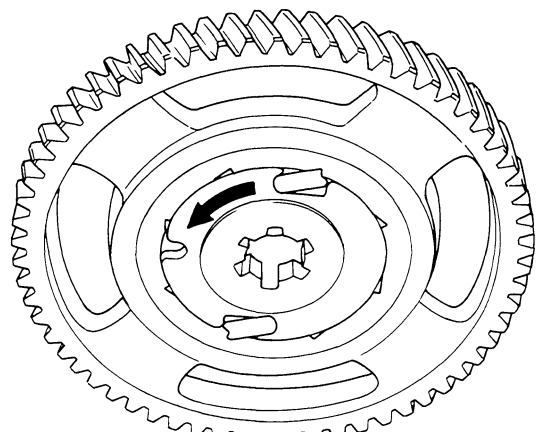

One way clutch

The FZ50 is equipped with a fully automatic, 2-speed, transmission. Two, separate, centrifugal clutches are used to select 1st and then 2nd gear. At lower engine RPM's, the low speed clutch (Clutch No. 1) labeled ④ engages. The power from the crankshaft ① is directed through the low speed clutch ④ into the 1st drive gear ⑤ and then to the 1st driven gear ⑥. As the driven gear is forced to rotate, small engagement dogs "lock" the gear to an inner shaft (Counter shaft) ⑦ which is then forced to also rotate. Splined to the inner counter shaft ⑦ is the chain drive sprocket ⑧. When the engine r/min increases clutch No. 2 ⑩ engages for 2nd gear power transmission. As the clutch begins to engage it forces the counter shaft ⑦ to turn faster than the r/min produced by the drive of the 1st driven gear set ⑥. This is accomplished by the use of a one-way or free-wheeling clutch inside of the 1st driven gear assembly. The one-way clutch is disengaged whenever the input speed of the inner portion, which is driven by the counter shaft, is higher than the driven portion of the outer gear. The power flow from the higher geared clutch No. 2 ⑩ now is connected through the counter shaft ⑦ to the chain drive sprocket ⑧.

DRIVE CHAIN

Power is transmitted from the counter shaft to the final drive shaft through a drive chain. The drive chain is maintained at the proper tension by the chain tensioners provided for the upper and lower parts of the chain and is immersed in transmission oil – oil bath type – ensuring excellent durability.

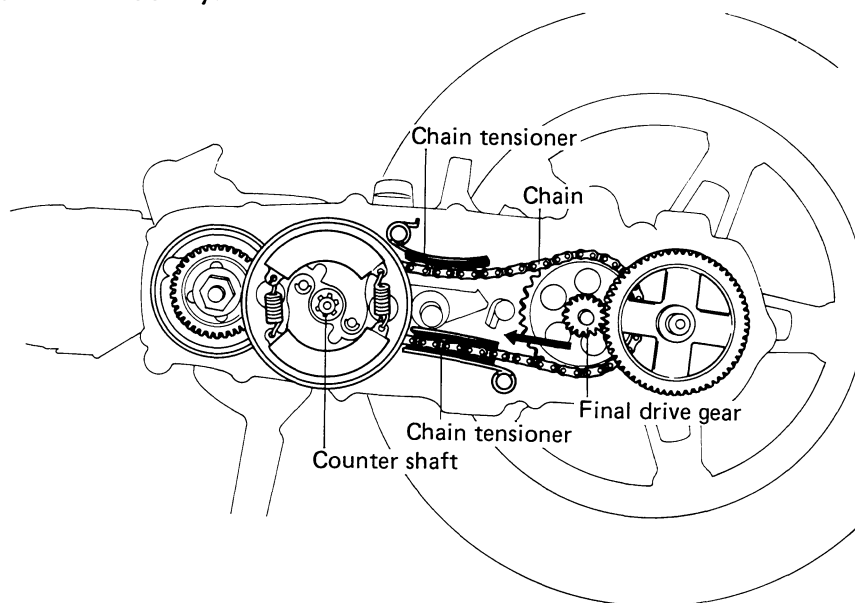

FINAL DRIVE

Power transmitted to the final drive shaft through the drive chain. The driven sprocket and final drive gear are press-fitted to the final drive shaft. The speed is reduced by the final drive gear and the final driven gear mounted on the drive axle shaft.

The drive axle shaft is integrated with the final driven gear, and it rotates at a speed reduced finally by the final drive gear. The shaft is installed in the rear part of the crankcase. Almost half of the drive axle shaft projects outside and is splined to the rear wheel, thus causing it to turn.

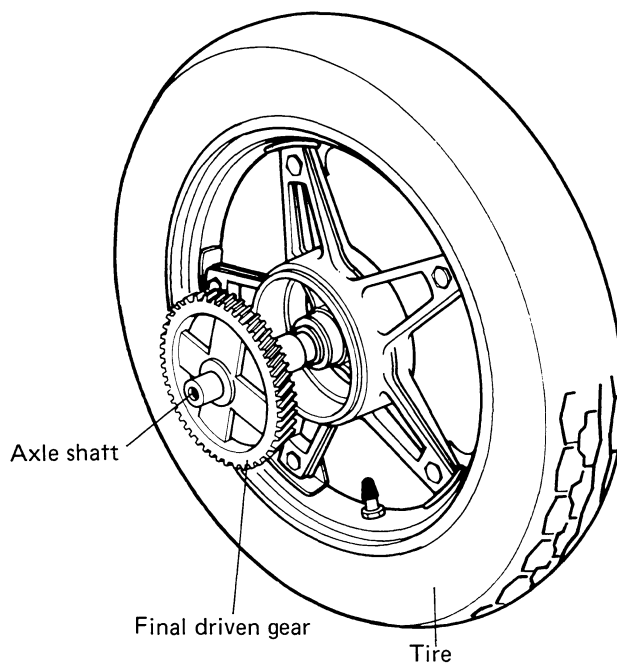

KICK STARTER

When the brake lever is squeezed, the kick starter lifter lever is actuated, the kick starter lifter shaft rotates and the kick starter lifter moves downward. By the movement of the kick starter lifter, the kick starter guide is pushed and the guide end is raised. Keeping this condition, when the kick lever is depressed, the kick starter is turned by the kick starter drive gear. As a result, the kick starter moves to the left side of the kick idle gear while being turned by the kick starter gear and meshes with the kick idle gear. The kick idle gear rotates and makes the crankshaft turn.

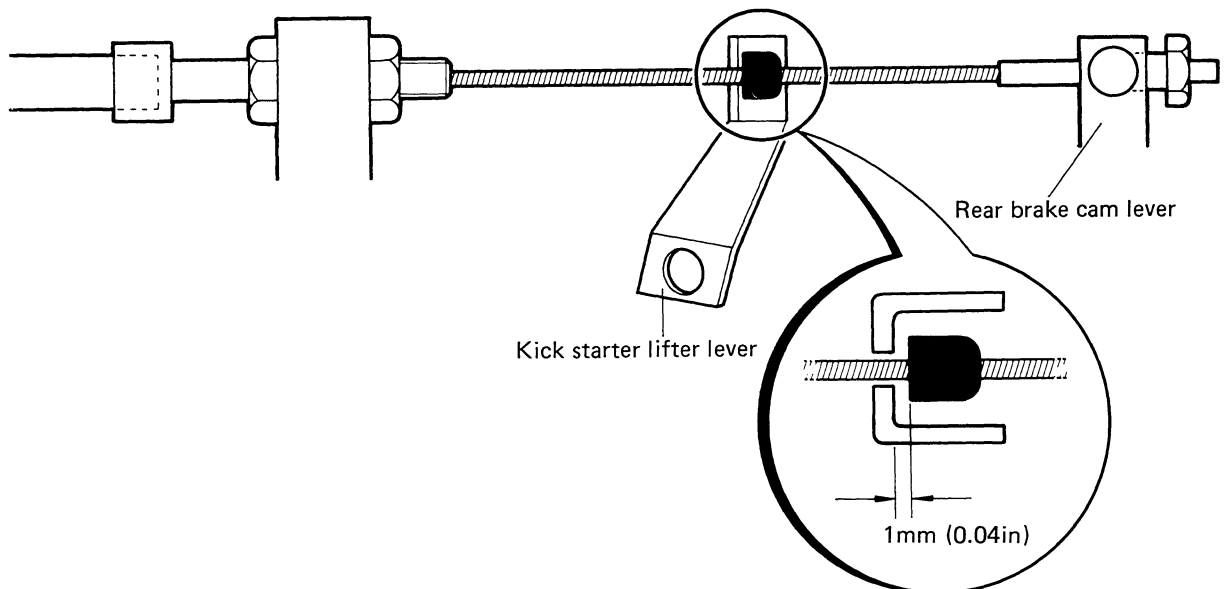
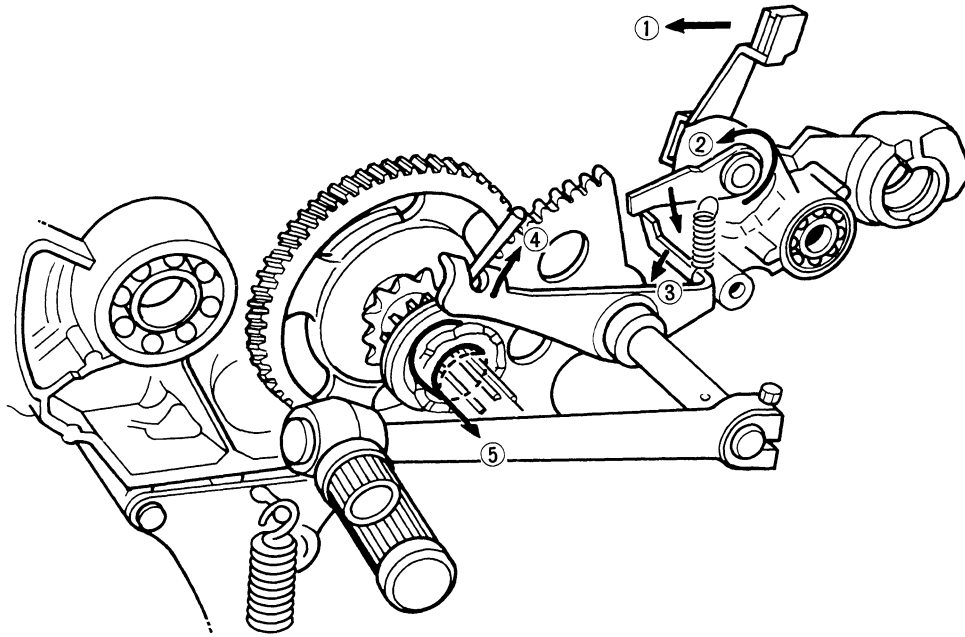

“PEI” SYSTEM

In the FZ50 ignition system, the PEI system is used.

The PEI system uses a magneto as the power source, and the capacitor (condenser) momentarily stores a charge up to hundreds of volts.

The charge is instantly discharged, at the specified ignition timing, to the ignition coil primary winding, thus inducing a high surge of voltage in the secondary winding. As a result, a spark occurs at the spark plug gap.

The PEI magneto has no breaker points and therefore it is free from mechanical trouble. This ensures a stabler secondary high voltage and better spark performance.

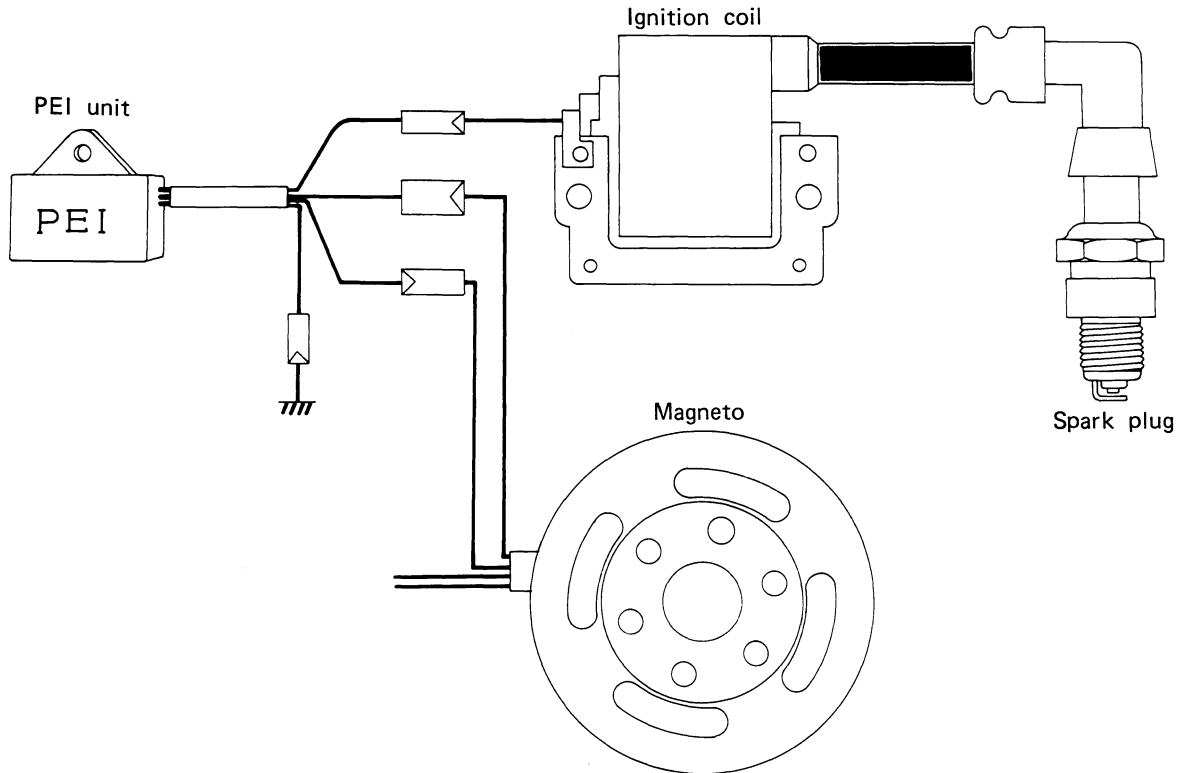

Features of “PEI” System

1. Spark plug deposits are minimized as high voltage spark is produced.
2. Disuse of contact points means no dust trouble. Contact points become worn by dust and such as a spark occurs between them.
3. Original engine performance is kept as ignition timing is always correct.
4. Running cost is reduced as “PEI” system has no mechanical parts and therefore requires no adjustment or replacement.

Connecting Diagram

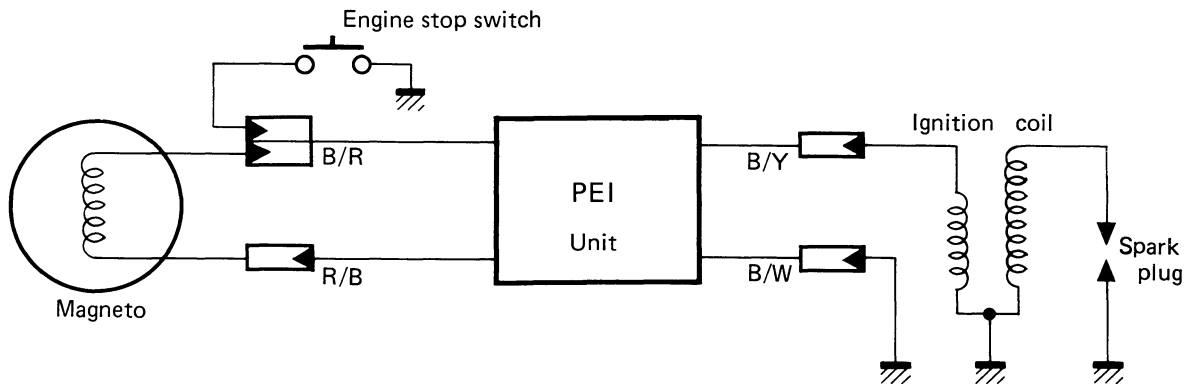

Wiring Circuit

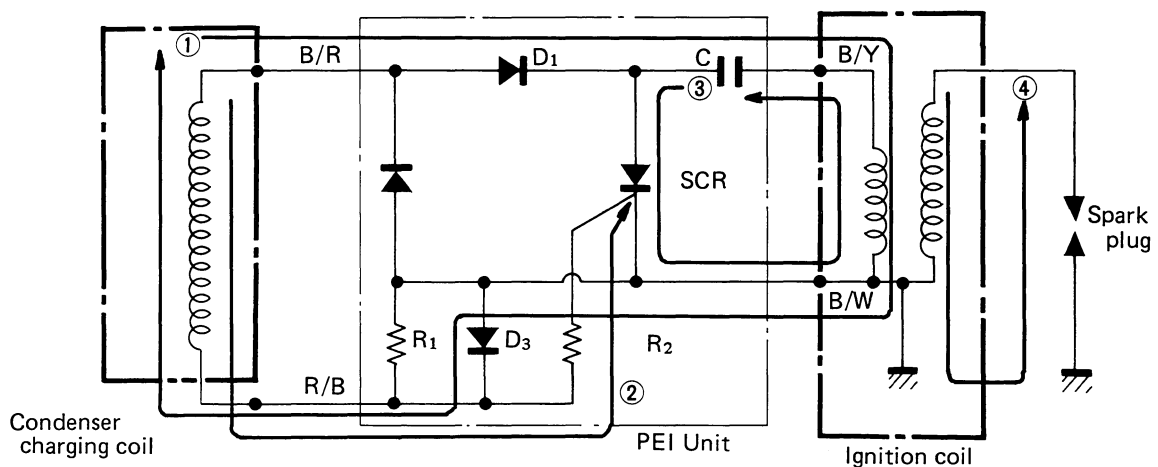

Description

- As the magneto turns, the voltage generated by the condenser charging coil is charged to the condenser through the following circuit:
Condenser charging coil \rightarrow Diode D_1 \rightarrow Condenser C \rightarrow Ignition coil primary winding \rightarrow Diode D_3 \rightarrow Condenser charging coil.
- When the rotor turns 180° , the polarity of the red/black terminal becomes positive (+) and the generated voltage, which is divided by R_1 , is applied through R_2 to the SCR gate. When this voltage arrives at the SCR gate, it makes SCR conduct (turned on).
- When SCR conducts, the electrical charge stored in the condenser is rapidly discharged through the following circuit:
Condenser C \rightarrow SCR \rightarrow Ignition coil primary winding \rightarrow Condenser C .
- In this way, a high surge of voltage quickly builds up in the secondary winding, thus causing a good spark to jump across the spark plug gap.

NOTE:

In case of PEI, two sparks occur each crankshaft rotation.

STEERING

To make maintenance work more efficient, steering is now installed with a single bolt. As the bolt is tightened, V shape of the end piece expands till it contacts the inside of the head pipe and is fixed there.

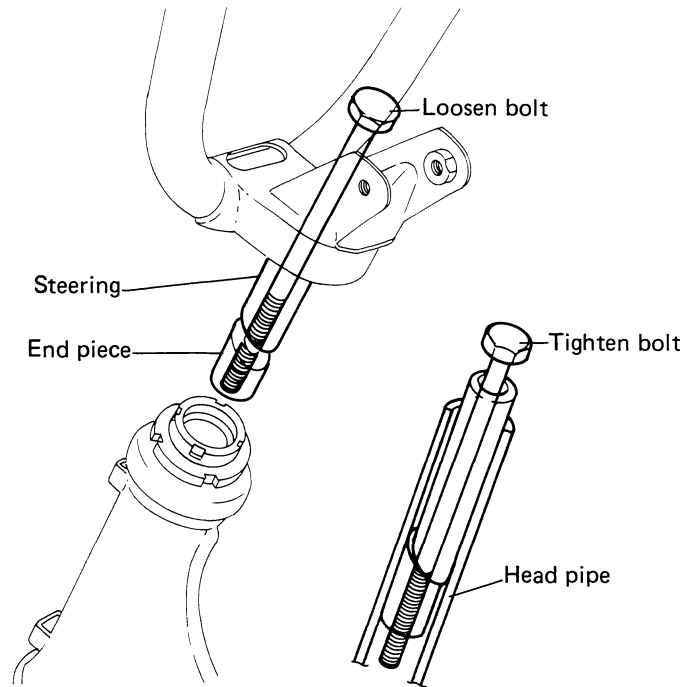

FRONT FORK

Front suspension of leading link type assures soft and comfortable riding. Road shocks are transmitted to the arm by way of the front axle shaft and absorbed in the shock absorber. On the contrary, when the shock absorber extends, the arm contacts the damper rubber and thus shocks are dampened.

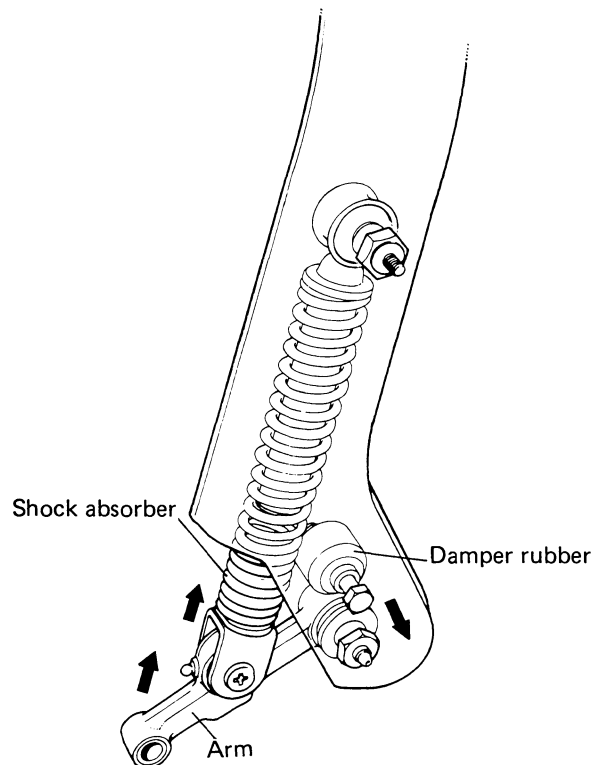

INSPECTION AND ADJUSTMENT

CONTENTS

PERIODIC MAINTENANCE SCHEDULE	2-2
MAINTENANCE PROCEDURE	2-3

PERIODIC MAINTENANCE SCHEDULE

Vehicles should be inspected after a certain period of running for wear of parts, carbon deposits, elongated cables, etc. Inspections should be made periodically and defects should be repaired or adjusted beforehand to prevent trouble and prolong the motorcycle's service life.

Inspect and adjust the vehicle as indicated below.

NOTE:

More frequent maintenance may be performed on motorcycles that are used in an extreme severe condition.

PERIODIC MAINTENANCE CHART

Interval		Initial	Every	Every
Item	Km	1 000	3 000	6 000
	Miles	600	2 000	4 000
	Month	2	6	12
Air cleaner element		Wash and clean	Wash and clean	—
Battery		Check specific gravity and service electrolyte solution	Check S.G. and service electrolyte solution	—
Brakes		Adjust play	Adjust play	—
Brake shoes		—	Check wear	—
Carburetor		Adjust idle r/min	Adjust idle r/min	Overhaul and clean
Cylinder head and cylinder		Retorque head nuts and exhaust pipe bolts	Retorque head nuts and exhaust pipe bolts	Remove carbon
Chassis bolts and nuts		Retorque	Retorque	—
Fuel line		Replace every 2 years		
Fuel filter		Clean	—	Clean
Oil pump		Check operation and adjust control lever	Check operation and adjust control lever	—
Spark plug		Clean	Clean and adjust gap	Replace
Steering		Check play	Check play	—
Throttle cable		Adjust play	Adjust play	—
Tire		Check tire pressure	Check tire pressure and tread wear	—
Transmission oil		Change	Change	—

LUBRICATION CHART

Rotating and rubbing parts must be lubricated periodically. Insufficient lubrication will cause rapid wear and severe damage may result.

Lubricate the following parts periodically.

Interval		Every	Every
Item	Km	3 000	6 000
	Mile	2 000	4 000
	Month	6	12
Brake cables		Motor oil	–
Brake cam shaft		–	Grease
Choke cable		Motor oil	–
Front suspension arm shaft		–	Grease
Oil pump cable		Motor oil	–
Speedometer gear		–	Grease
Speedometer cable		–	Grease
Throttle cable		Motor oil	–

WARNING:

Be careful not to apply too much grease to the brake cam shafts. If grease gets on the linings, brake slippage will result.

Lubricate exposed parts which are subject to rust, with either motor oil or grease whenever the motorcycle has been operated under wet or rainy conditions.

Before lubricating each part, clean off any rusty spots and wipe off any grease, oil, dirt or grime.

MAINTENANCE PROCEDURE

AIR CLEANER

Clean at initial 1 000 km and every 3 000 km

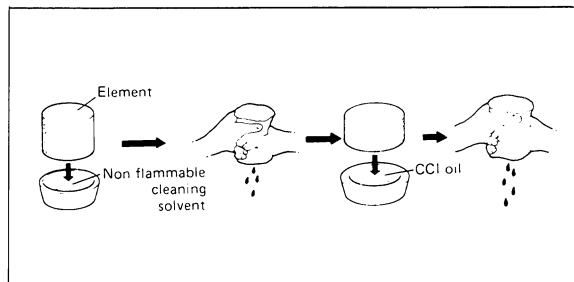

CAUTION:

- * Before and during the cleaning operation, examine the element to see if it is torn. A torn element must be replaced.
- * Be sure to position the element snugly and correctly, so that no incoming air will bypass it. Remember, rapid wear of piston rings and cylinder bore is often caused by a defective or poorly fitted element.

BATTERY

Check at initial 1 000 km and every 3 000 km

Electrolyte for specific gravity	1.260 at 20° C (68° F)
----------------------------------	------------------------

- Check to be sure that the vent pipe is secure and routed properly.
- Add distilled water, as necessary, to keep the surface of the electrolyte above the LOWER level line but not above the UPPER level line.

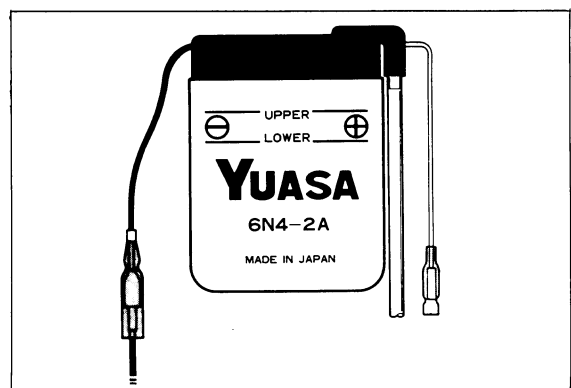
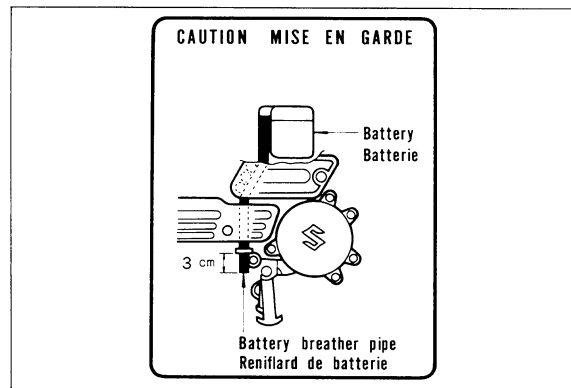

- If the electrolyte surface falls rapidly and requires frequent addition of distilled water, check the charging system for proper charging rate.
- A S.G. reading of 1.220 (at 20° C, 68° F) or under means that the battery needs recharging off the machine: take it off and charge it from a recharger. Charging the battery in place from the recharger can damage the rectifier and related wiring.

Charging current	0.4 A/10 hours
------------------	----------------

S.G.	Condition	Measure
over 1.250	Normal	—
1.220 – 1.250	Under charged	Better to recharge
below 1.220	Run down	Recharge or replace

CAUTION:
Do not forget to remove three battery caps to prevent possible battery damage when recharging.

BRAKES

Adjust at initial 1 000 km
and every 3 000 km

- Adjust by turning the adjusting nut so that the clearance between grip and brake lever is 20 – 30 mm (0.8 – 1.2 in) when applying the front brake.

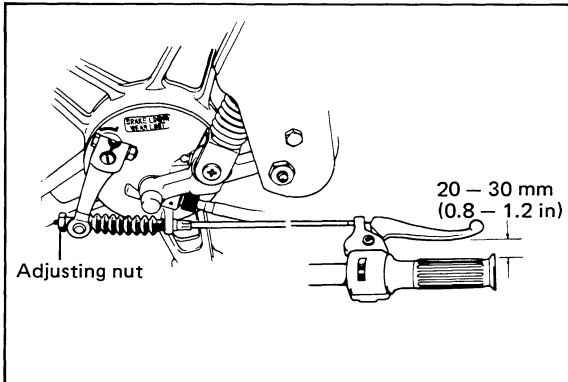

- As the rear brake wire is linked to the kick starter lifter lever, first adjust with the adjusting nut so that the lifter lever play is 1 mm (0.04 in).

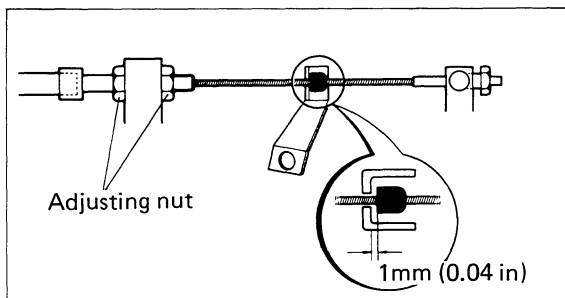

- Adjust by turning the brake cable adjusting nut so that the clearance between lever and grip is 20 – 30 mm (0.8 – 1.2 in).

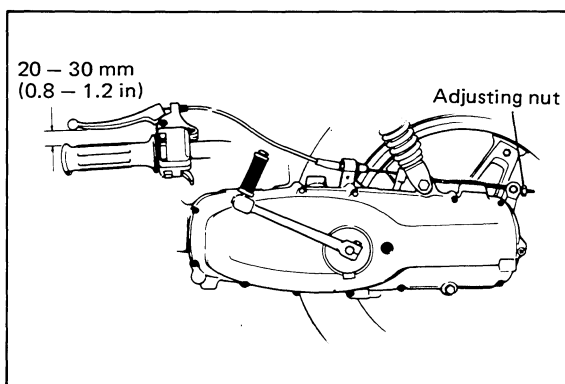

BRAKE SHOE WEAR

Check every 3 000 km

- When applying the front brake, if the extended line of the brake cam lever exceeds the range on the brake panel, replace the brake shoes.

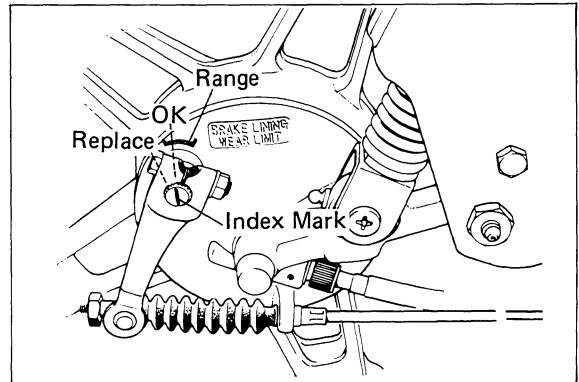

- Remove inspection cap on the rear hub panel and check the brake shoes. If they are worn as much as the limit shown in the figure below, replace them.

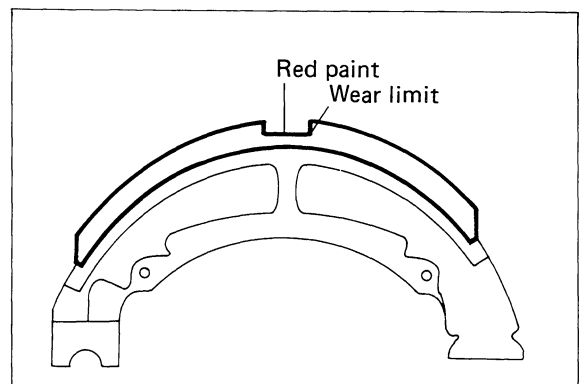
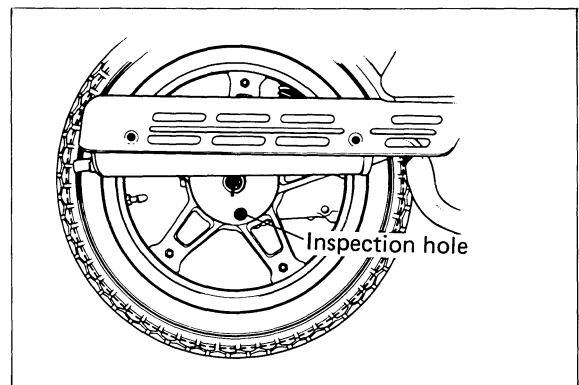

ENGINE IDLE R/MIN

Adjust at initial 1 000 km and every 3 000 km

- Adjust the throttle cable play.
- Warm the engine up.

NOTE:

A warm engine means an engine has been run for 10 minutes.

- Turn the air screw back $1\frac{3}{4}$ turns from the bottom.
- Restart engine, and set the throttle valve stop screw at lowest idle speed.
- Turn the air screw in or out within $\frac{1}{4}$ turn from the original setting ($1\frac{3}{4}$ turns). Find the position where the engine runs at the highest r/min. Turn the air screw in $1/8$ turn.
- Adjust the throttle stop screw to obtain the idling r/min as follows.

Idle r/min	1 350 – 1 650 r/min
------------	---------------------

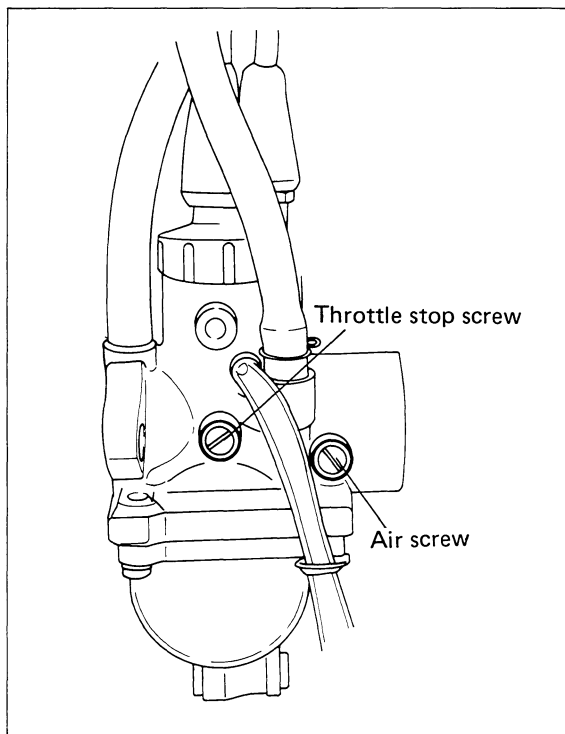

- Finally adjust the throttle cable play. (Refer to page 2-12.)

Throttle cable play	0.5 – 1.0 mm (0.02 – 0.04 in)
---------------------	----------------------------------

CAUTION:

This adjustment will affect the oil pump lever adjustment. Therefore, re-adjust the oil pump lever cable as necessary.

CARBURETOR OVERHAUL AND CLEANING

Overhaul and clean every 6 000 km

Wash the carburetor and component parts in cleaning solvent after disassembly.

Before reassembly, inspect the float level and needle valve. Adjust and replace parts when necessary. (Refer to page 3-11.)

Then blow compressed air through all jets and passages to make sure they are not clogged. Do not use wire, etc. to clean them, as this can damage the parts.

CYLINDER HEAD NUTS

Retighten at initial 1 000 km and every 3 000 km

- Cylinder head nuts, when they are not tightened to the specified torque, may result in leakage of the compressed mixture and reduce output. Tighten the 4 nuts evenly one by one in stages until each one is tightened to the specified torque. Tighten the nuts in the order indicated below.

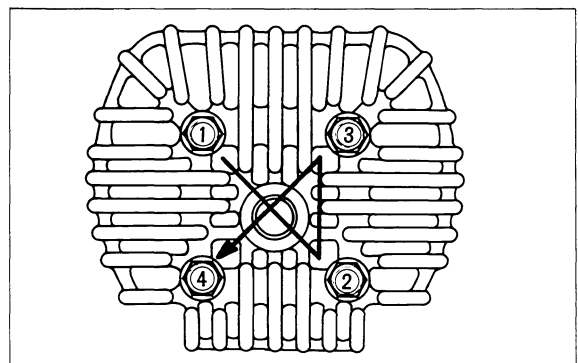

Cylinder head nut tightening torque	0.8 – 1.2 kg-m (6.0 – 8.5 lb-ft)
--	-------------------------------------

CYLINDER HEAD AND CYLINDER

Remove carbon every 6 000 km

Carbon deposits in the combustion chamber and the cylinder head will raise the compression ratio and may cause pre-ignition or overheating. Carbon deposited at the exhaust port of the cylinder will prevent the flow of exhaust, reducing the output. Remove carbon deposits periodically.

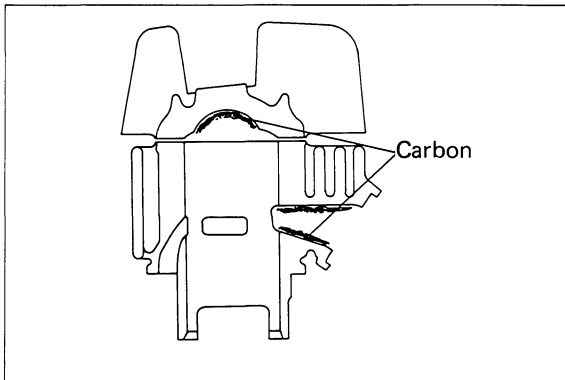

FUEL LINE

Replace every two years

Replace the fuel line every two years.

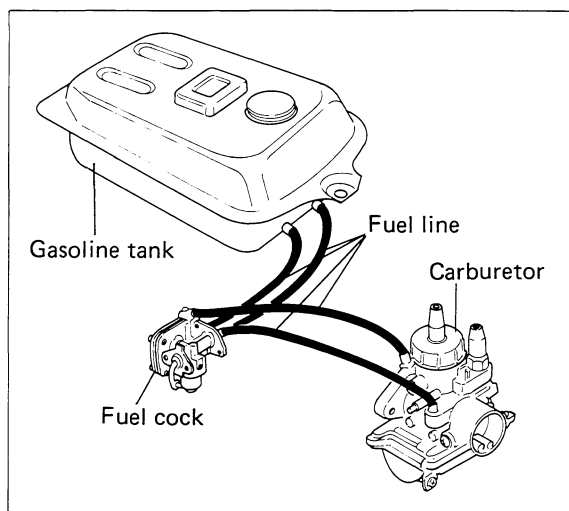

FUEL STRAINER

Clean at initial 1 000 km
and every 6 000 km

If the fuel strainer cup is dirty with sediment or water, gasoline will not flow smoothly and a loss in engine power may result. Clean the strainer cup, leaving the cock lever in ON position.



OIL PUMP

Adjust at initial 1 000 km
and every 3 000 km

Cable adjustment

The engine oil is fed by the oil pump to the engine. The amount of oil fed to it is regulated by engine speed and the oil pump control lever which is controlled by the amount of throttle opening.

Check the oil pump in the following manner to confirm correct operation for all throttle valve opening positions.

- Turn the throttle grip until the dent mark ① on the throttle valve comes to the upper part of the hole.

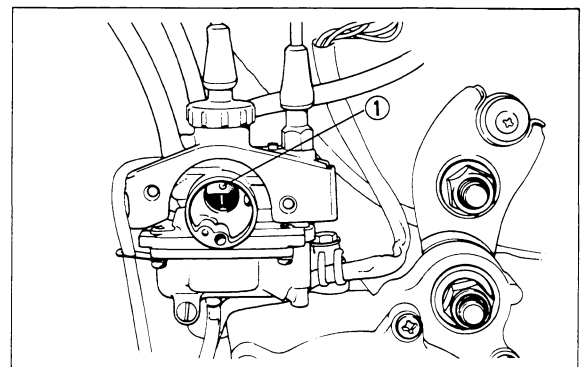

- Check whether the mark on the oil pump control lever is aligned with the index mark when the throttle valve is positioned as above.

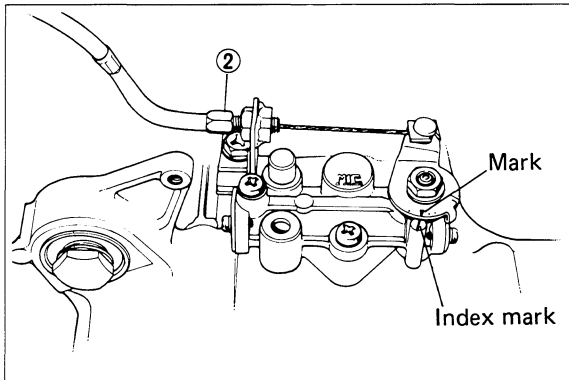

- If the marks are not aligned, adjust by means of the cable adjuster ② to align them.

Air bleeding

Whenever evidence is noted of some air having leaked into the oil line from the oil tank in a machine brought in for servicing, or if the oil pump has to be removed for servicing, be sure to carry out an air bleeding operation with the oil pump in place before returning the machine to the user.

How to bleed the air: With the engine not running condition, loosen screw ①, to let out the air; and, after making sure that the trapped air has all been bled, tighten the screw good and hard.

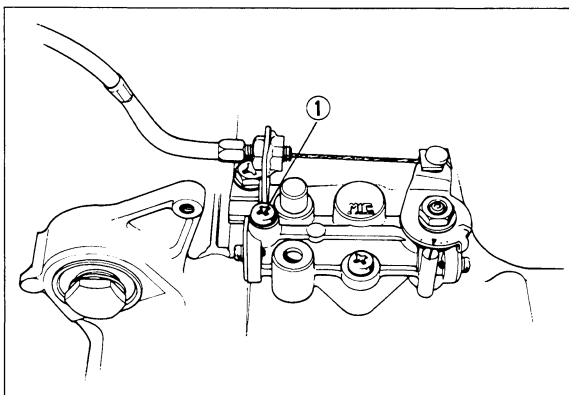

Checking oil pump capacity

Use the special tool, check the pump for capacity by measuring the amount of oil the pump draws during the specified interval.

Engine oil discharge amount measuring tool	09900-21602
--	-------------

- Have the tool filled with SUZUKI CCI SUPER 2 OIL and connect it to the suction side of the pump.

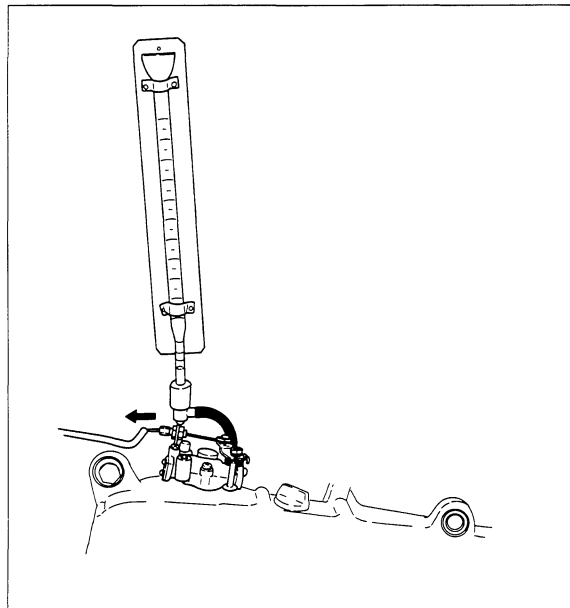

- Holding engine speed at the 2 000 r/min by turning the throttle stop screw, move the lever up to the fully open position and let the pump draw for 6 minutes. For this operation, the reading taken on the measuring cylinder should be from 1.02 to 1.26 ml.

Oil discharge amount (fully open position)	1.02 — 1.26 ml at 2 000 r/min for 6 minutes
--	---

SPARK PLUG

Check at initial 1 000 km
and every 3 000 km
Replace every 6 000 km

Neglecting the spark plug eventually leads to difficult starting and poor performance. If the spark plug is used for a long period, the electrode gradually burns away and carbon builds up along the inside part. In accordance with the Periodic Inspection Chart, the plug should be removed for inspection, cleaning and to reset the gap.

- Carbon deposits on the spark plug will prevent good sparking and cause misfiring. Clean the deposits off periodically.
- If the center electrode is fairly worn down, the plug should be replaced and the plug gap set to the specified gap using a thickness gauge.

Thickness gauge	09900-20803
-----------------	-------------

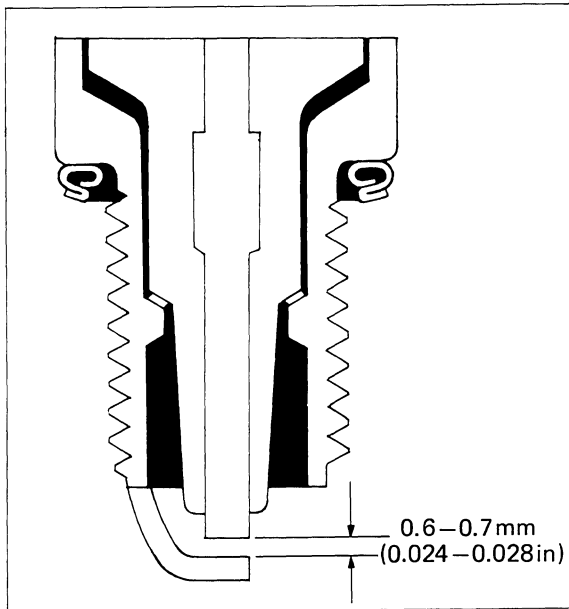

Spark plug gap	0.6 – 0.7 mm (0.024 – 0.028 in)
----------------	------------------------------------

- Check spark plug for burnt condition. If abnormal, replace the plug as indicated below.

NGK	Nippon Denso	Remarks
BP-2HA	W9FP-UL	If the standard plug is apt to get wet, replace with this plug.
BP-4HA	W14FP-UL	Standard
BP-5HA	W16FP-UL	If the standard plug is apt to overheat, replace with this plug.

- Tighten the spark plug in the cylinder head with the specified torque.

Spark plug tightening torque	2.5 – 3.0 kg-m (18.0 – 21.5 lb-ft)
------------------------------	---------------------------------------

STEERING STEM

Check at initial 1 000 km
and every 3 000 km

Steering should be adjusted properly for smooth manipulation of handlebars and safe running. Too stiff steering prevents smooth manipulation of handlebars and too loose steering will cause the handlebars to vibrate. Check to see that there is no play in the front fork fitting.

If any play can be found, adjust the steering as follows:

- Support the motorcycle body and jack up the front wheel.
- Remove the headlight housing.
- Loosen the steering stem nut securing nut ①, tighten the steering stem nut ② using the special tool so that the front fork moves smoothly.

Steering stem nut wrench	09940-10122
--------------------------	-------------

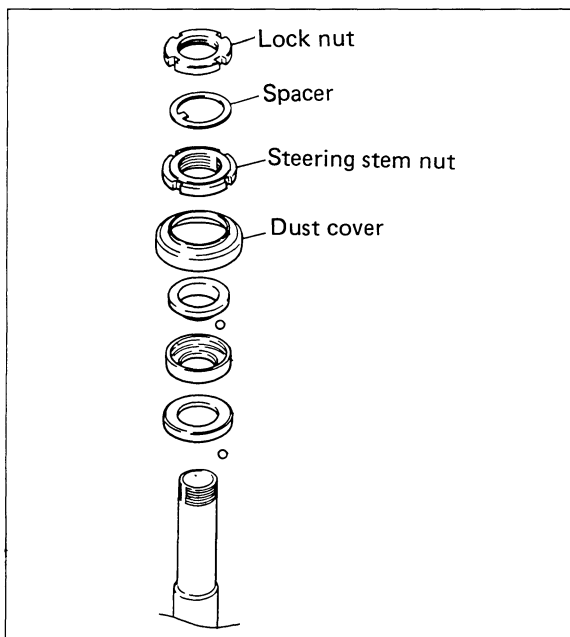

If any play is still found, inspect the following items and replace the affected parts, if necessary.

- Wear of the inner and outer races
- Wear or damage of steel balls
- Number of steel balls (upper 22 pcs lower 25 pcs)
- Distortion of steering stem

THROTTLE CABLE

- Loosen the lock nut and adjust the cable slack by turning adjuster in or out to obtain the following slack.
After adjusting slack, tighten the lock nut.

Cable slack	0.5 – 1.0 mm (0.02 – 0.04 in)
-------------	----------------------------------

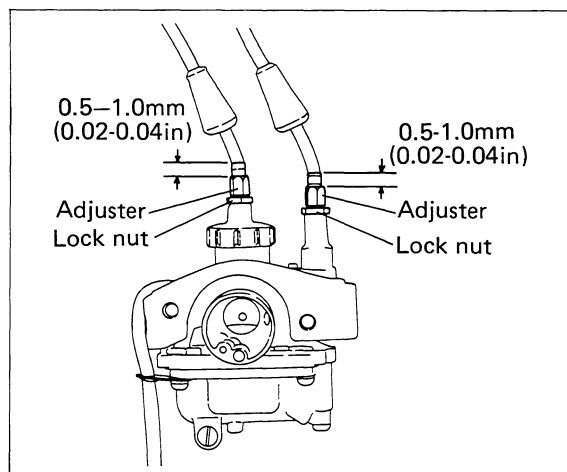

CAUTION:

This adjustment will affect the oil pump control lever adjustment. Re-adjust the oil pump control cable adjustment.

TIRE

Check every 3 000 km

Tire pressure

If the tire pressure is too high, the motorcycle will tend to ride stiffly, have poor traction. Conversely, if the tire pressure is too low, stability will be adversely affected. Therefore, maintain the correct tire pressure for good roadability and to prolong tire life.

Cold inflation tire pressure	
Front	Rear
125 kpa (1.25 kg/cm ² , 18 psi)	150 kpa (1.50 kg/cm ² , 21 psi)

CAUTION:
The standard tire fitted on this motorcycle is 3.00-12-4PR for front and rear. The use of a tire other than the standard may cause handling instability. It is highly recommended to use a SUZUKI Genuine Tire.

Tire tread condition

Operating the motorcycle with the excessively worn tires will decrease riding stability and consequently invite a dangerous situation. It is highly recommended to replace the tire when the remaining depth of tire tread reaches the following specifications.

FRONT and REAR	1.6 mm (0.06 in)
----------------	------------------

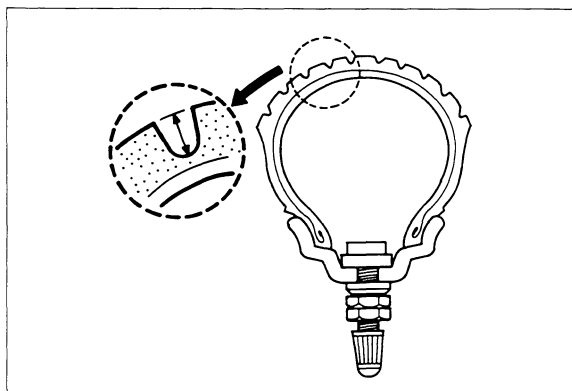

TRANSMISSION OIL

Change at initial 1 000 km and every 3 000 km

After a long period of use, the transmission oil qualities will deteriorate and quicken the wear of sliding and interlocking surfaces. Replace the transmission oil periodically following the procedure below.

- Start the engine to warm up the oil, this will facilitate draining of oil.
- Unscrew the oil filler cap and drain plug, and drain the oil completely.
- Tighten the drain plug.
- Supply a good quality SAE 20W/40 multi-grade motor oil.

Capacity	800 ml (0.85/0.70 US/Imp qt)
----------	---------------------------------

- Check the oil level with the oil level screw.

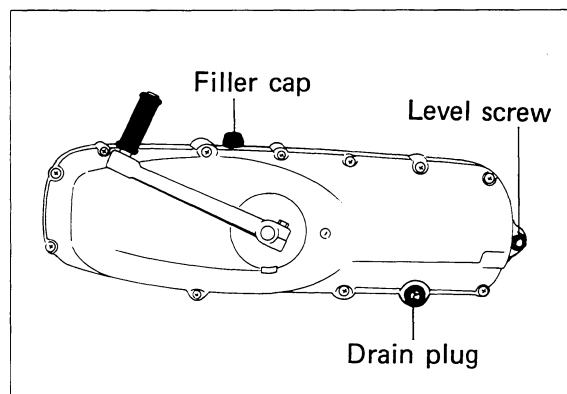

CHASSIS BOLTS AND NUTS

Retighten at initial 1 000 km and every 6 000 km

These bolts and nuts listed below are important safety parts. They must be retightened, as necessary, to the specified torque with a torque wrench.

No.	Description	Q'ty	kg-m	lb-ft
①	Front brake cam lever nut	1	0.5 – 0.8	4.0 – 5.5
②	Front shock absorber lower nut	2	1.0 – 1.5	7.5 – 10.5
③	Front suspension arm rear nut	2	2.0 – 3.0	14.5 – 21.5
④	Front suspension arm damper nut	2	1.0 – 1.5	7.5 – 10.5
⑤	Front shock absorber upper bolt	2	1.5 – 2.0	11.0 – 14.0
⑥	Rear shock absorber upper nut	1	2.0 – 3.0	14.5 – 21.5
⑦	Rear shock absorber lower nut	1	2.0 – 3.0	14.5 – 21.5
⑧	Rear brake cam lever nut	1	0.5 – 0.8	4.0 – 5.5

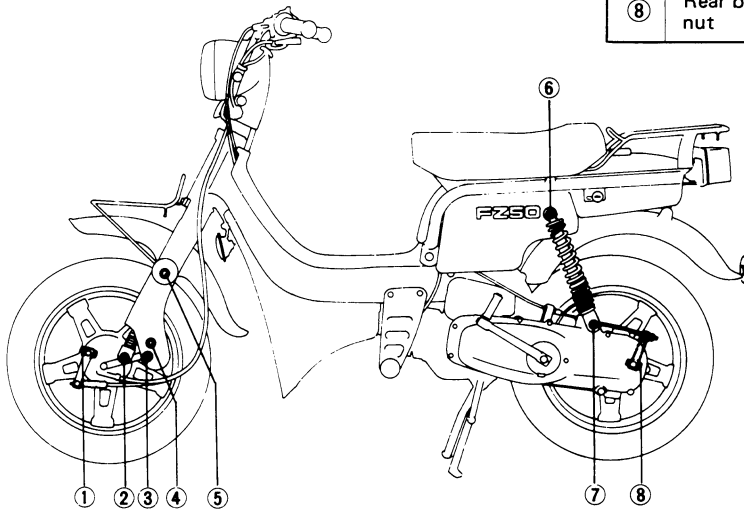

No.	Description	Q'ty	kg-m	lb-ft
⑨	Rear axle nut	1	3.6 – 5.2	26.5 – 37.5
⑩	Engine mounting nut	1	2.5 – 4.0	18.5 – 28.5
⑪	Front footrest nut	2	1.0 – 1.5	7.5 – 10.5
⑫	Handlebar expander bolt	1	5.0 – 6.5	36.5 – 47.0
⑬	Front axle nut	1	2.7 – 4.3	20.0 – 31.0

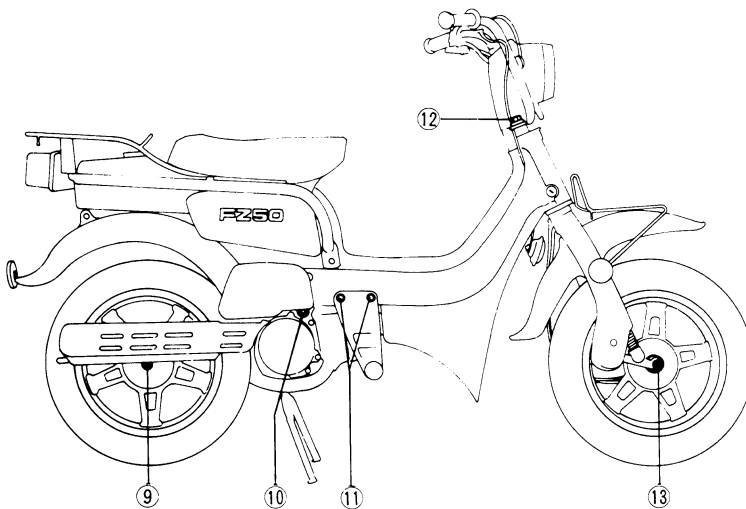

SERVICING PROCEDURE

CONTENTS

ENGINE REMOVAL/INSTALLATION.....	3- 2
CYLINDER HEAD, CYLINDER, PISTON.....	3- 3
KICK STARTER, LEFT COVER	3- 5
POWER TRANSMISSION	3- 6
LEFT CRANKCASE	3-10
CRANKSHAFT	3-11
CARBURETOR.....	3-13
FLYWHEEL MAGNETO	3-14
CHASSIS ELECTRICAL	3-16
SWITCHES	3-20
STEERING	3-22
FRONT SUSPENSION	3-23
WHEELS AND BRAKES	3-24

ENGINE REMOVAL/INSTALLATION

Right Side

- ① Remove the magneto lead wire.
- ② Remove the fuel line and the vacuum line with the fuel cock set to ON.
- ③ Remove the carburetor choke cable from the carburetor side.
- ④ Remove the carburetor top cover.
- ⑤ Loosen the engine mounting nut.

Left Side

- ① Remove the spark plug cap.
- ② Remove the oil pump control cable.
- ③ Remove the oil hose.
- ④ Remove the rear brake cable.
- ⑤ Loosen and remove the rear shock absorber lower bolt.
- ⑥ Remove the engine ground wire from the ignition coil side.
- ⑦ Pull out the engine mounting bolt.
- ⑧ Lift the body.

Right

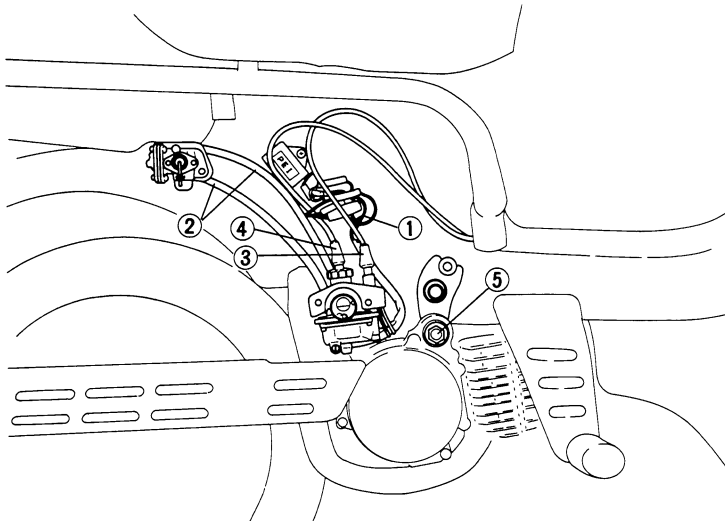

⑤

	2.5 – 4.0 kg-m (18.5 – 28.5 lb-ft)
---	---

Left

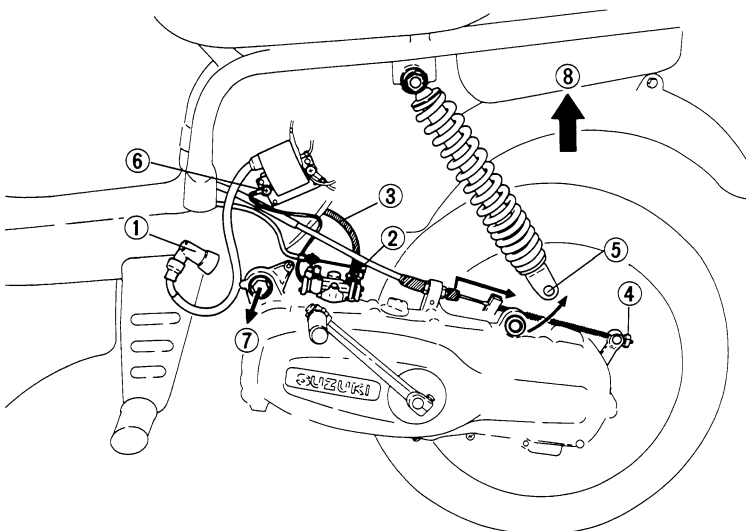

⑤

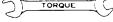
	2.0 – 3.0 kg-m (14.5 – 21.5 lb-ft)
---	---

CYLINDER HEAD, CYLINDER, PISTON, PISTON RING

①

	0.8 – 1.2 kg-m (6.0 – 8.5 lb-ft)
--	---

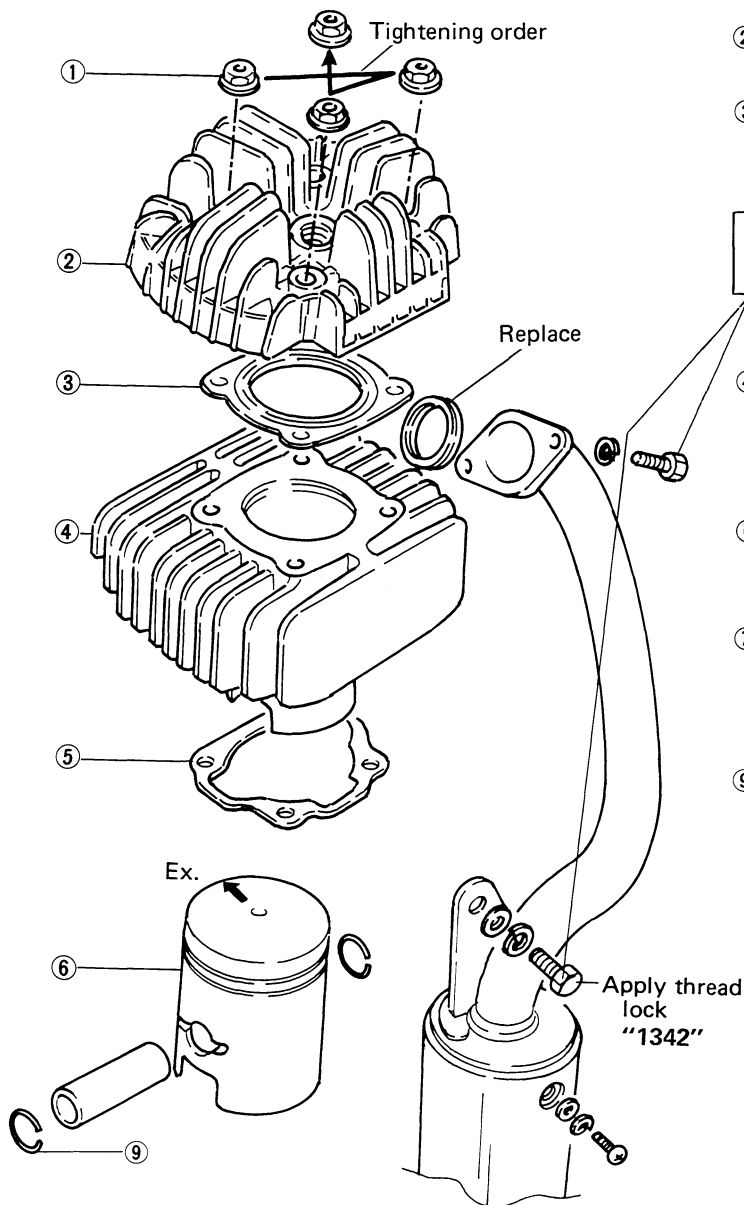

- ② Remove carbon
- ③ ⑤ Replace gasket

	2.0 kg-m (14.0 lb-ft)
--	--

- ④ Remove carbon of the exhaust port and apply oil on the cylinder wall.
- ⑥ Arrow mark on the piston crown faces exhaust side.
- ⑦, ⑧ Remove carbon and apply oil. Top mark "R" or "T" indicates up-side on rings.
- ⑨ Replace with new circlips.

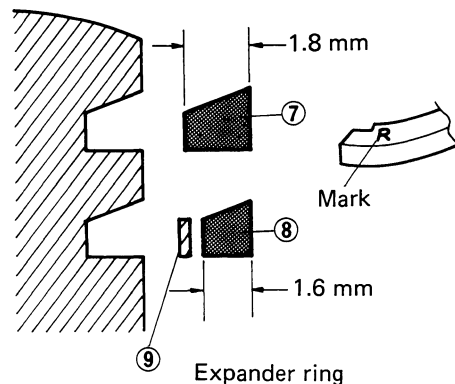

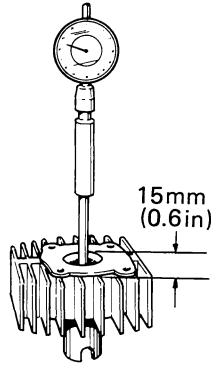

CYLINDER BORE

Cylinder gauge	09900-20508
Service Limit	41.060 mm (1.6165 in)

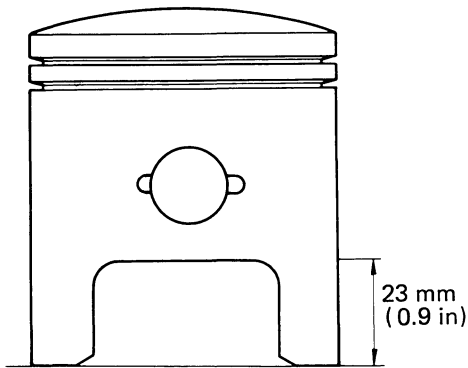

PISTON DIAMETER

Micrometer	09900-20202
Service Limit	40.880 mm (1.6094 in)

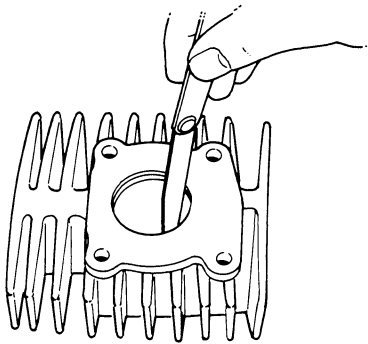

RING END GAP

Thickness gauge	09900-20804
Service Limit	0.75 mm (0.030 in)

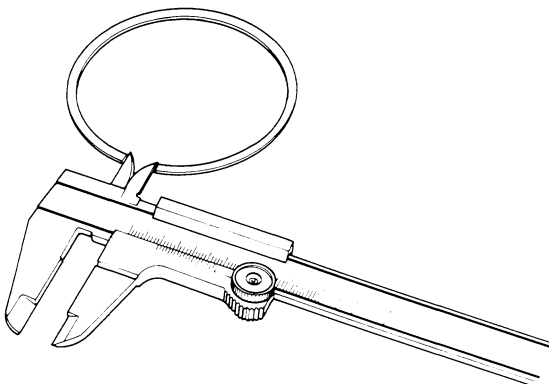

RING FREE END GAP

Vernier caliper	09900-20101	
Service Limit	R marked	T marked
	3.6 mm (0.14 in)	4.0 mm (0.16 in)

NOTE:
Replace the piston rings as a set.

KICK STARTER, LEFT COVER

Bearing remover	09921-20210
Sliding shaft	09930-30102

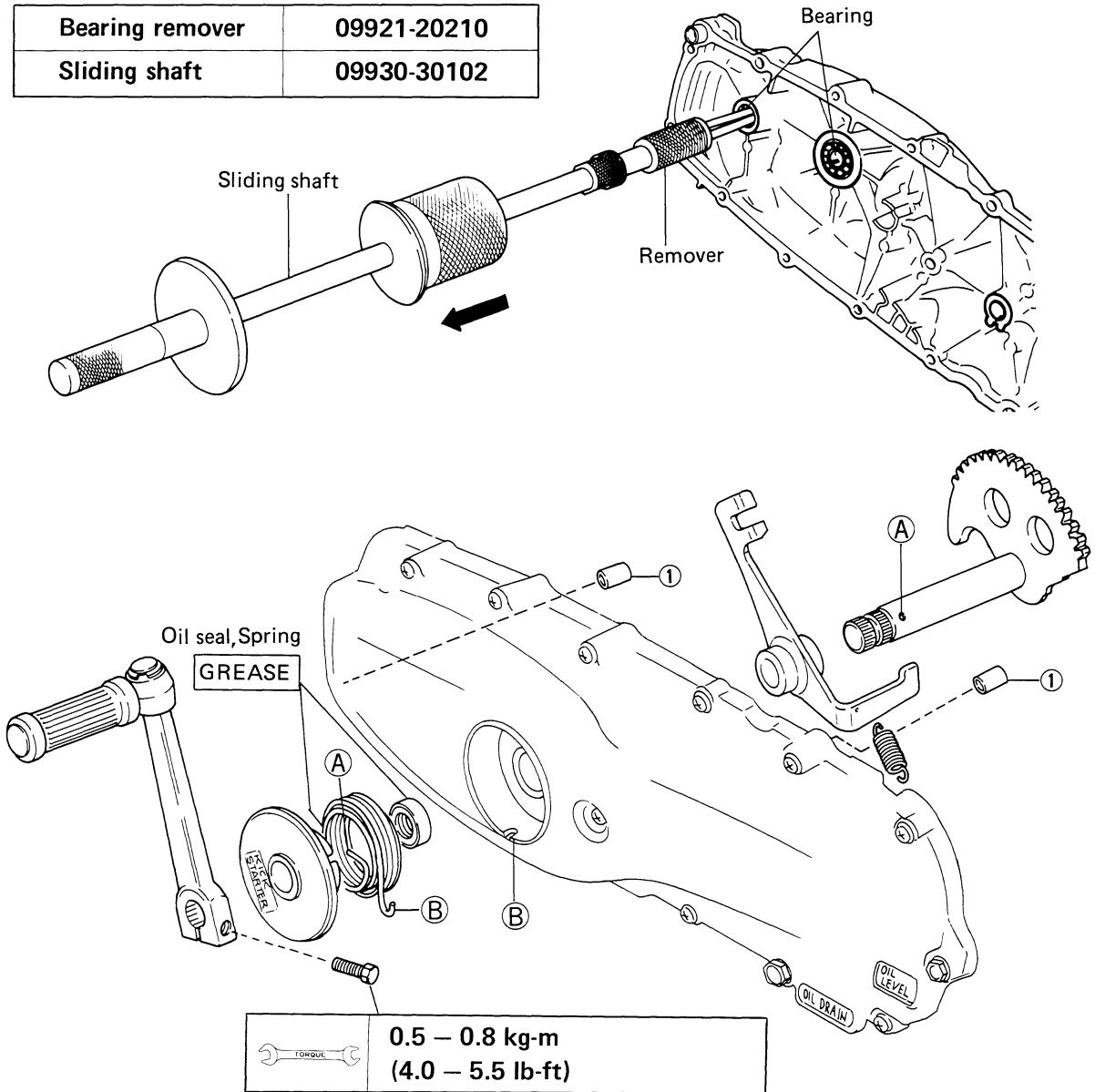

- When installing the kick starter return spring, install ① and then install ②.
- Apply Suzuki Super Grease A to the oil seal lip and the kick starter spring.
- Replace the gasket.
- Install two dowel pins ①.

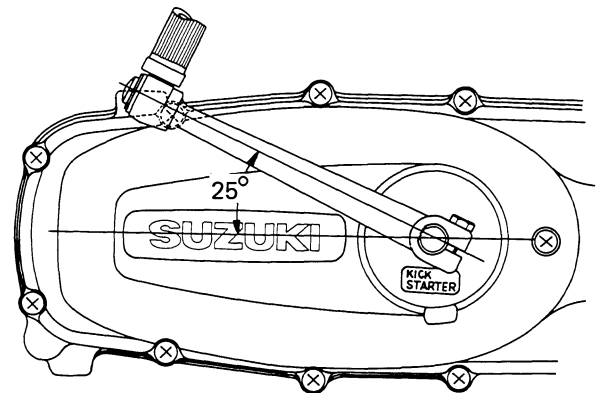

POWER TRANSMISSION

①

Clutch holder	09920-30220
----------------------	--------------------

- Apply thread lock cement.

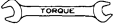
	2.0 – 3.0 kg-m (14.5 – 21.5 lb-ft)
---	---

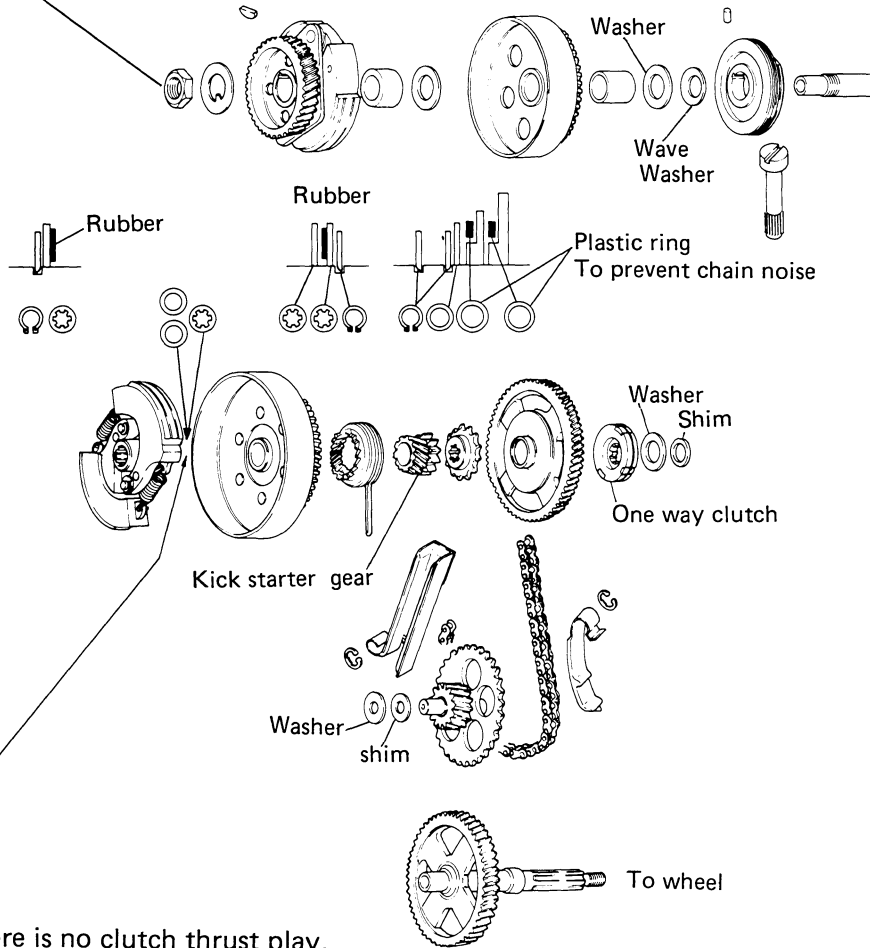
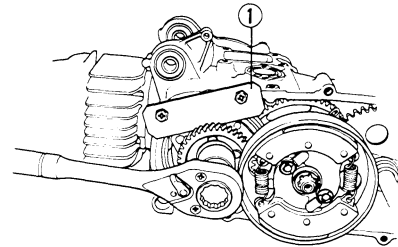

Adjust so that there is no clutch thrust play.

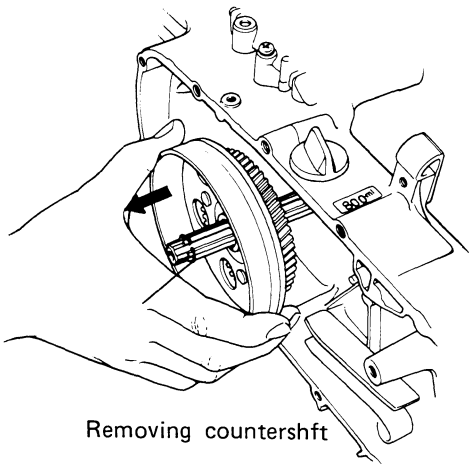

Removing countershaft

Circlip opener	09900-06107
-----------------------	--------------------

- Replace all circlips.
- Adjust shim to reduce the final drive and driven gear noise.

AUTOMATIC CLUTCH INSPECTION

The FZ50 is equipped with an automatic clutch and automatic 2 speed transmission. The engagement of the clutches are governed by engine RPMs and a centrifugal mechanism located in the two independent clutches.

To insure proper performance and longevity of the clutch assemblies it is essential that the clutches engage smoothly and gradually. Three inspection checks must be performed to thoroughly check the operation of the drivetrain. Follow the procedures listed.

1. INITIAL ENGAGEMENT INSPECTION (CLUTCH NO. 1)

- Warm the motorcycle up to normal operating temperature.
- Connect an electric tachometer to the engine.
- Seated on the motorcycle with the motorcycle on level ground, increase the engine RPMs slowly and note the RPM at which the motorcycle begins to move forward.

ENGAGEMENT R/MIN

STD	2 500 r/min
Tolerance	±200 r/min

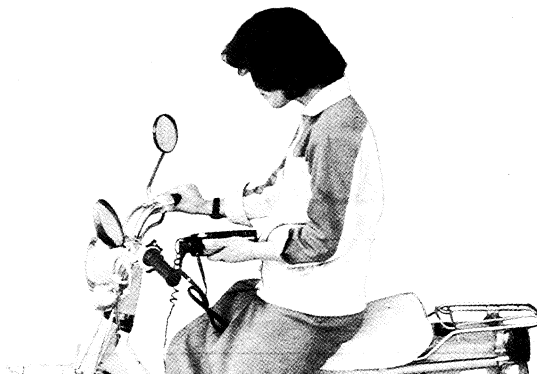

2. CLUTCH "LOCK-UP" INSPECTION (CLUTCH NO. 1)

Perform this inspection to determine if the clutch is engaging fully and not slipping.

- Warm the engine to normal operating temperatures.
- Connect an electric tachometer to the engine.
- Apply the rear brake as firm as possible.
- Briefly open the throttle fully and note the maximum engine RPMs sustained during the test cycle.

CAUTION:

Do not apply full power for more than 10 seconds or damage to the clutch or engine may occur.

LOCK-UP R/MIN

STD	3 800 r/min
Tolerance	±200 r/min

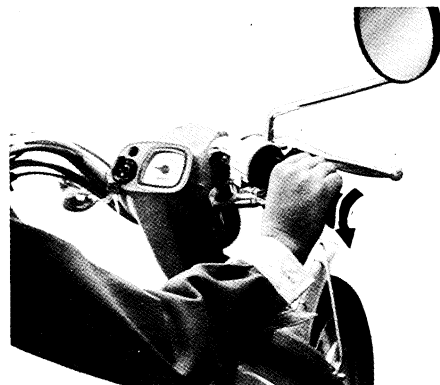
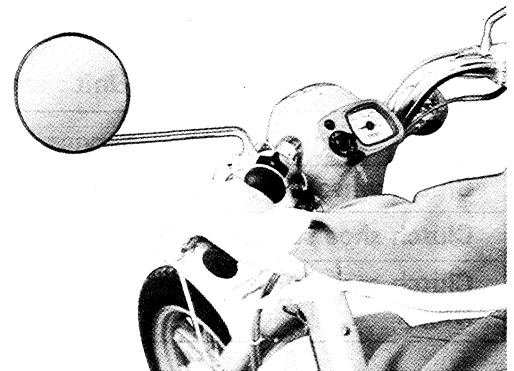

If the engine r/min does not coincide with the specified r/min range then disassemble the clutch.

- Clutch shoe – inspect the shoes visually for chips, cracking, uneven wear, burning and check the depth of the grooves on the shoes. If there is no groove at any part of the shoes, replace them as a set.
- Clutch springs – visually inspect the clutch springs for stretched coils or broken coils. Measure the free length of the springs with vernier calipers.

NOTE:
Clutch shoes or springs must be changed as a set and never individually.

- Clutch wheel – inspect visually the condition of the inner clutch wheel surface for scoring, cracks, or uneven wear. Measure the inside diameter of the clutch wheel with inside calipers. Measure the diameter at several points to check for an out-of-round condition as well as normal wear.

Unit : mm (in)

Item	Service limit
Clutch wheel I.D.	87.40 (3.441)
Clutch shoe surface	No groove
Clutch spring free length	28.0 (1.06)

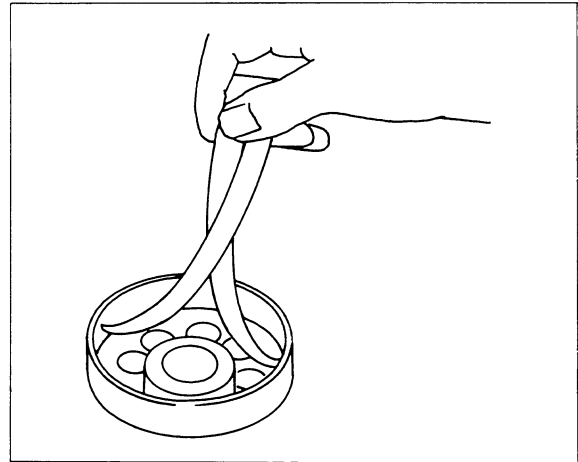

Measuring clutch wheel.

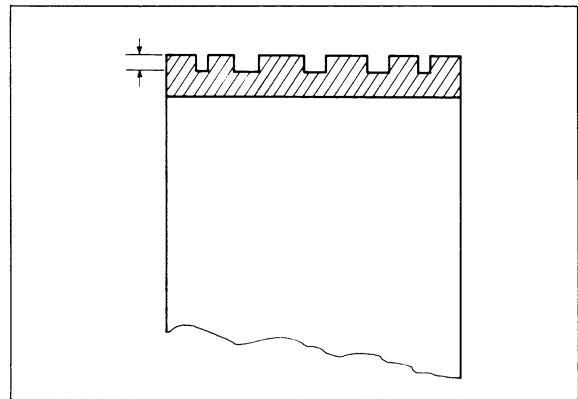

Inspecting clutch shoe groove.

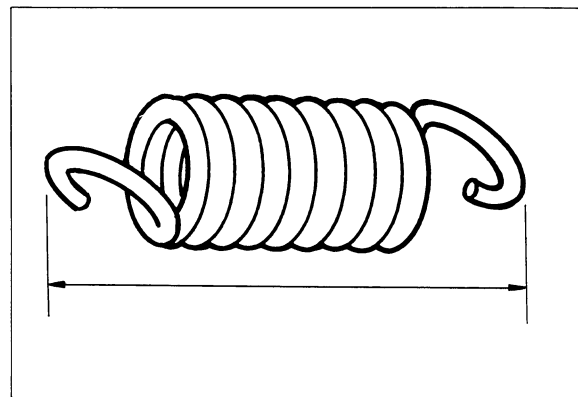

Measuring clutch spring.

3. SECOND GEAR SHIFT POINT

(CLUTCH NO. 2)

Ride the motor cycle in a normal manner and note at what road speed the transmission shifts to second gear.

2ND GEAR SHIFT POINT

STD	21 km/h (13 mph)
Tolerance	±2 km/h (±1 mph)

The 2nd gear shift should be both quick and smooth with no indications of slipping or grabbing.

If the shift point does not coincide with the standard MPH range then Clutch No. 2 components should be inspected in the same manner as was Clutch No. 1 in the following areas:

- Clutch shoes
- Clutch springs
- Clutch wheel

Unit : mm (in)

Item	Service limit
Clutch wheel I.D.	105.50 (4.154)
Clutch shoe surface	No groove
Clutch spring free length	33.0 (1.30)

CHAIN 20 PITCH LENGTH

Service limit	173.0 mm (6.83 in)
----------------------	---------------------------

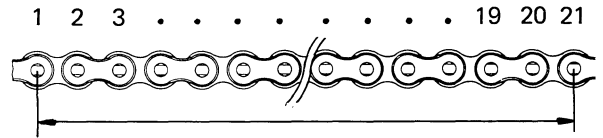

LEFT CRANK CASE

	0.5 – 0.8 kg-m (4.0 – 5.5 lb-ft)
---	---

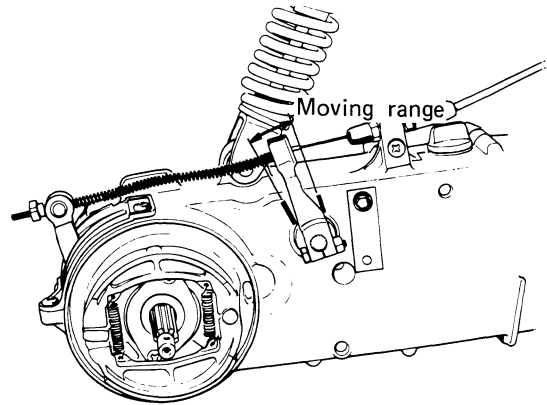
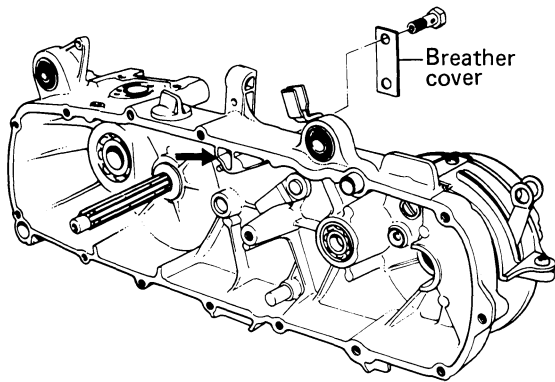

Push out as shown in the figure.

Install the circlip in the outermost groove and slide out the clutch and remove the countershaft.

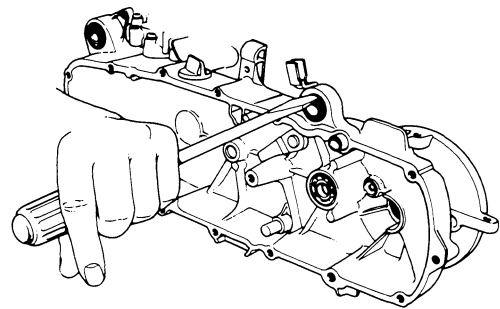
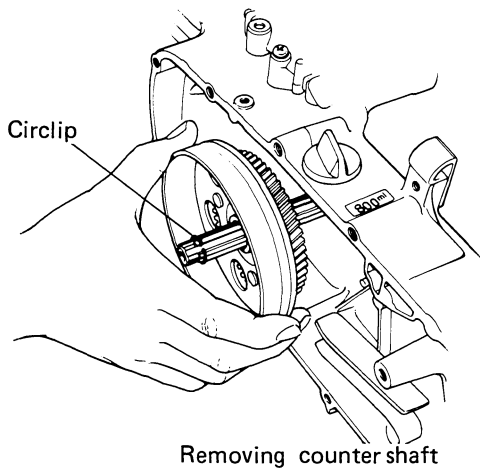

Removing counter shaft

NOTE:
 Remove the rear brake shoe and slide out the cam to the right. Be sure to mark the cam lever position before removal.

Pull out by using the bearing puller and sliding shaft.

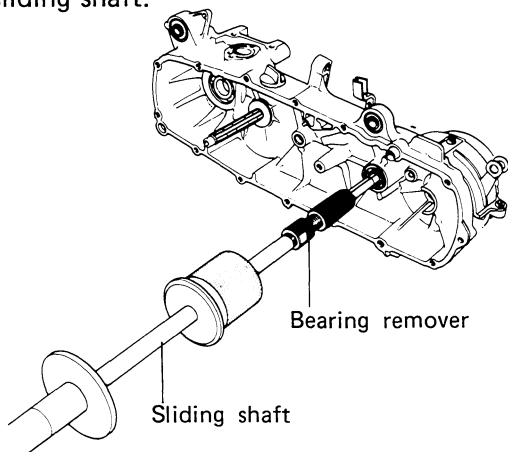

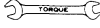
	0.5 – 0.8 kg-m (4.0 – 5.5 lb-ft)
--	---

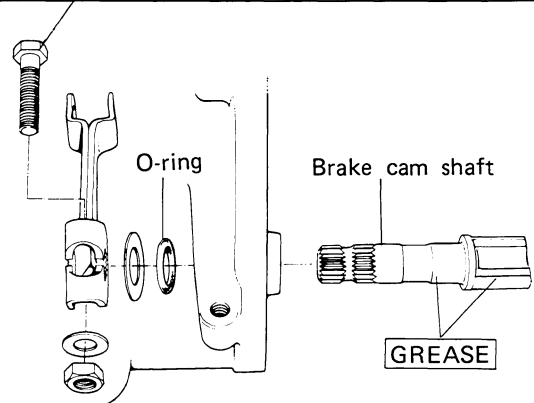

CRANKSHAFT

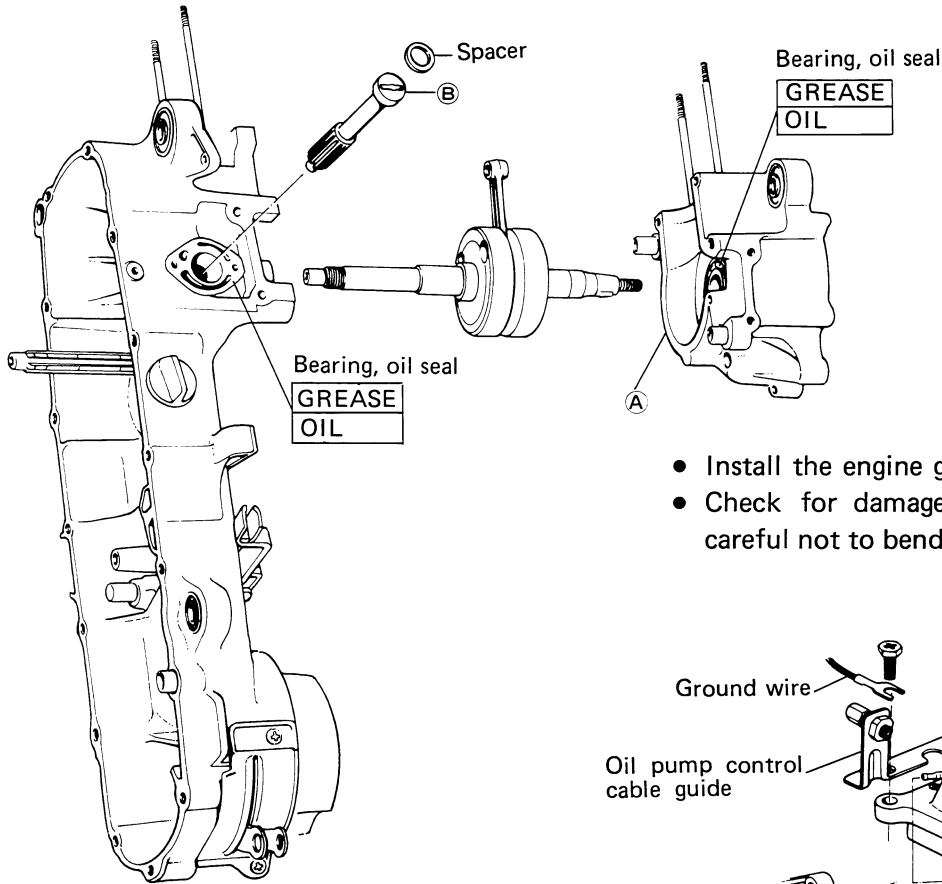

- Install the engine ground wire.
- Check for damage and bent reeds. Be careful not to bend the reed valve stopper.

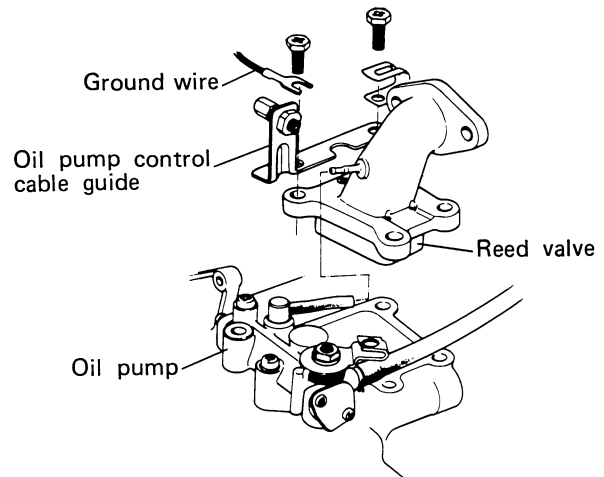

- Apply thread lock super "1303" to outer surface of right oil seal.

Thread lock super "1303"	99000-32030
--------------------------	-------------

- Clean the inlet port mounting surface and the case surface.
- When installing the crankshaft, apply the liquid gasket to ①.

SUZUKI Bond No. 1207B	99104-31140
-----------------------	-------------

- Be sure to set the spacer when installing the oil pump.
- Match the projecting part of oil pump and the groove ②.
- Check the oil seal and the bearing for damage or excessive clearance.
- Apply grease to the oil seal.
- Apply oil to the bearing.

- Use a crankshaft remover to prevent damage to the crankshaft bearing and crankshaft.

Crankshaft remover	09920-13120
--------------------	-------------

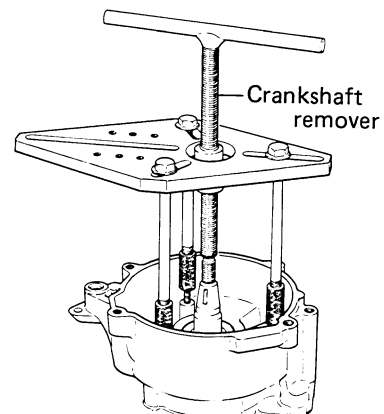

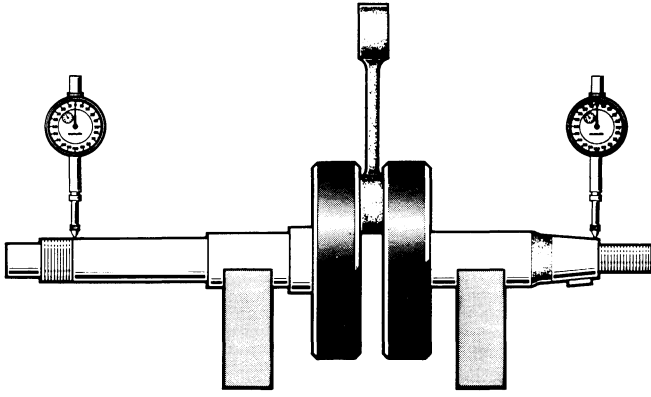

CRANKSHAFT DEFLECTION

Service limit	0.05 mm (0.002 in)
---------------	--------------------

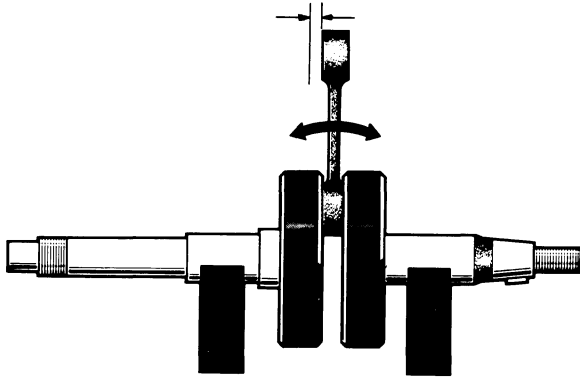

SMALL END DEFLECTION

Service limit	3.0 mm (0.12 in)
---------------	------------------

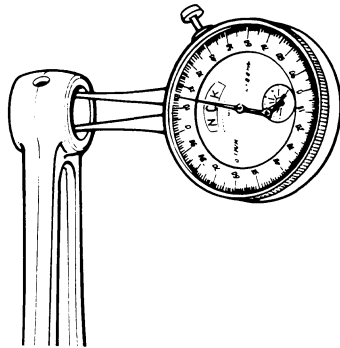

SMALL END BORE DIA.

Service limit	16.040 mm (0.6315 in)
---------------	-----------------------

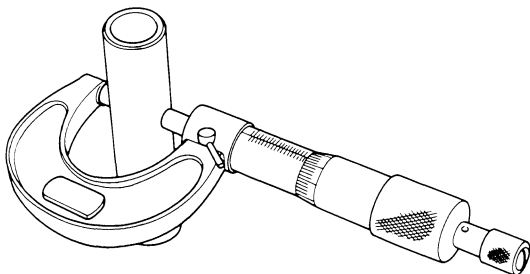

PISTON PIN O.D.

Service limit	11.980 mm (0.4717 in)
---------------	-----------------------

CARBURETOR

Clean each passage of air and fuel with an air gun.

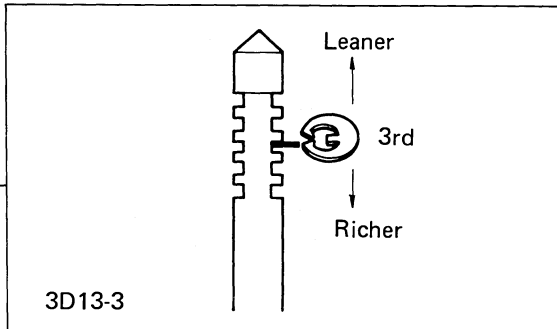
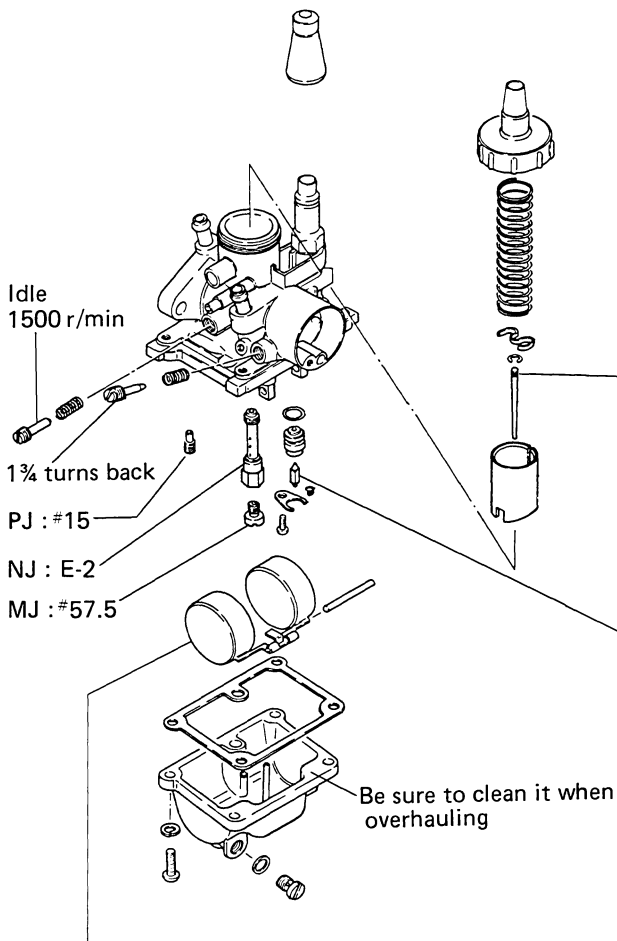

Check for damage and replace if any.

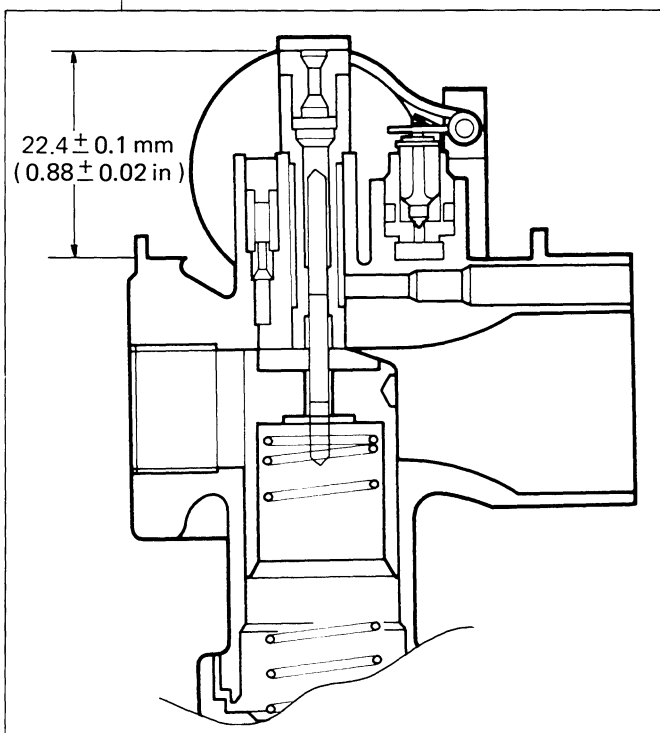
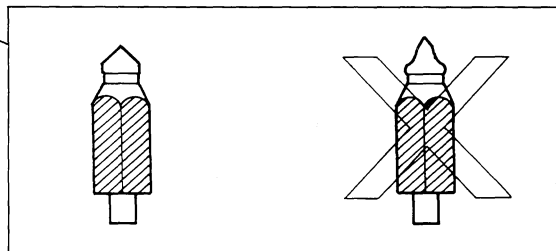

FLYWHEEL MAGNETO

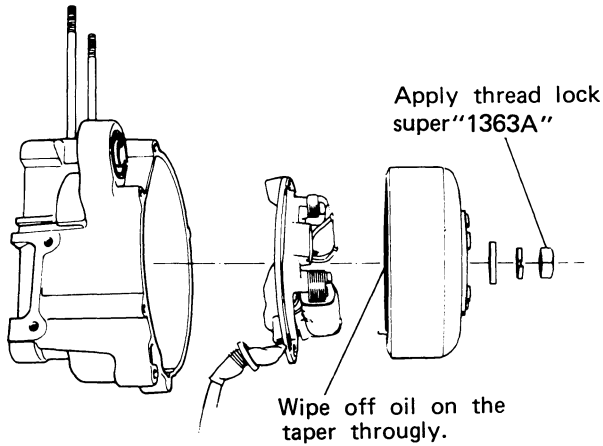

Flywheel holder	09930-40113
-----------------	-------------

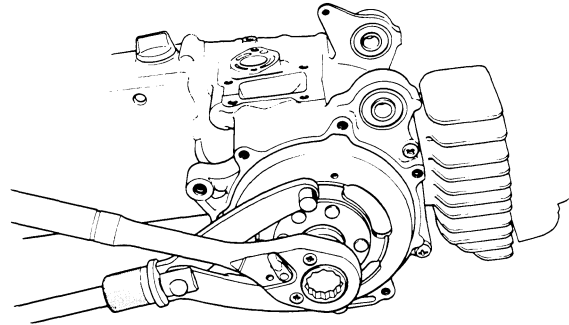

Sliding shaft	09930-30102
Attachment C	09930-30161

Fix the stator to align the scribed line with the center of the screw hole so that correct ignition timing is assured.

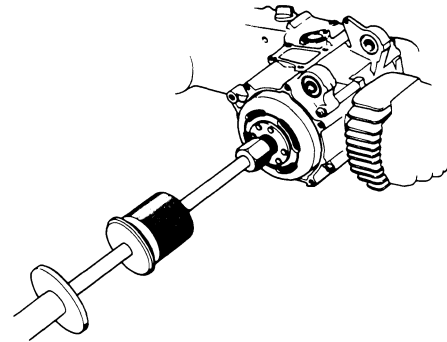
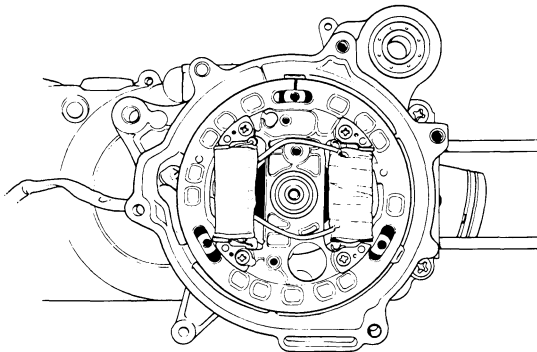

Wipe off oil on the taper thoroughly.

Timing advance

Timing retard

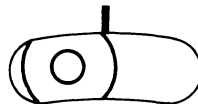
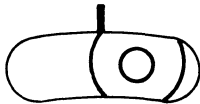

	3.0 – 3.5 kg-m (22.0 – 25.5 lb-ft)
--	---

Using a timing light, check whether the ignition timing is correct by running the engine at 4 000 RPM and noting that the marks are aligned properly.

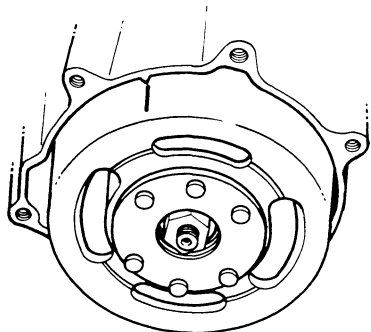

Timing advance

Timing retard

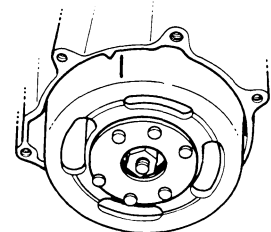
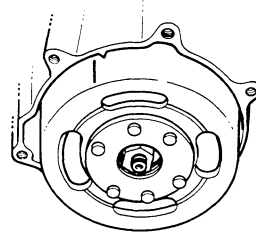

Specifications

- Ignition method: 2 sparks per crankshaft rotation
- Light capacity: 5.2 V or more at 2 500 r/min
8.5 V or less at 8 000 r/min
- Charging capacity: 0.7 A or more at 4 000 r/min
3.0 A or less at 8 000 r/min
- Secondary voltage: 12 kV or more at 500 – 8 000 r/min
- Ignition coil resistance: Primary Approx. 0.5 Ω
Secondary Approx. 15 k Ω

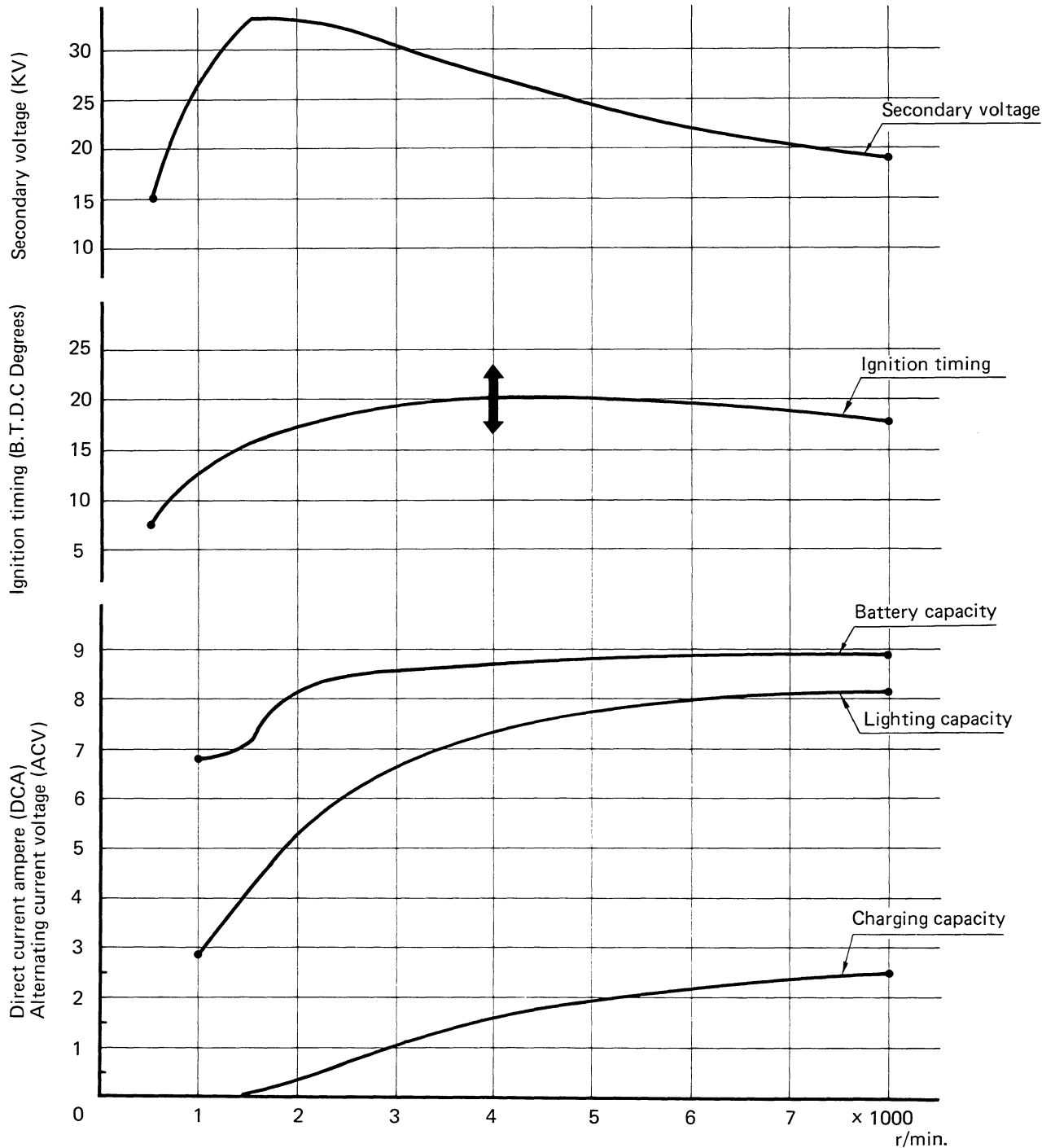

STATOR

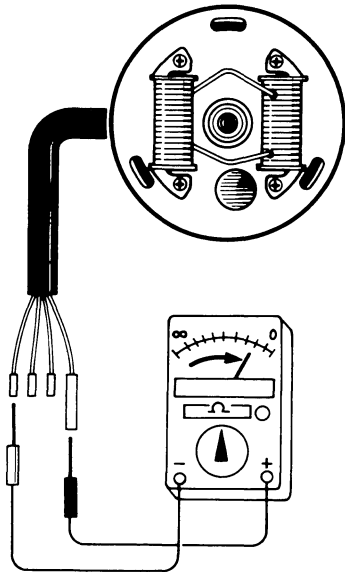

Pocket tester	09900-25002
---------------	-------------

- Select the knob to RX "x 1".
- Make a following continuity test.

Unit : (Ω)

	G	W/R	Y/R	B/R
Ground				
W/R	0.4 – 0.8			
Y/R	0.1 – 0.3	0.3 – 0.5		
B/R	OFF	OFF	OFF	
R/B	OFF	OFF	OFF	180 – 220

CHASSIS ELECTRICAL

IGNITION COIL

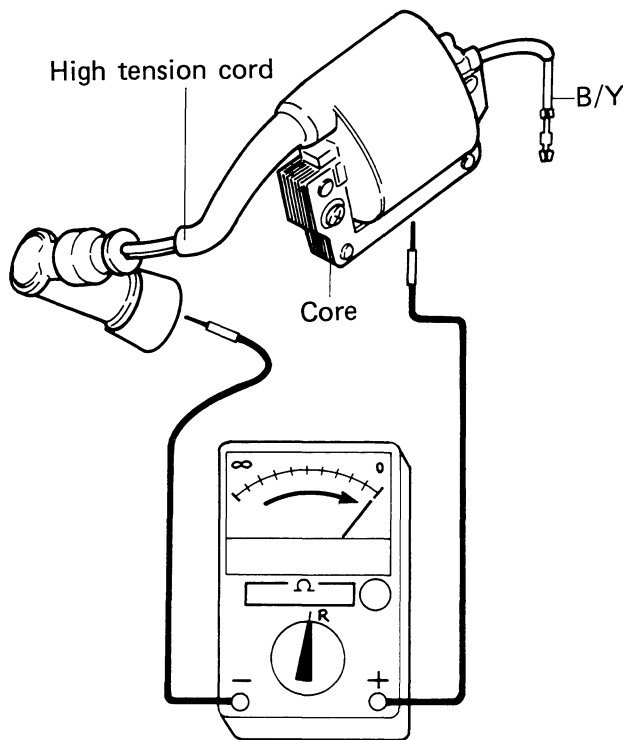

- Using the pocket tester check the ignition coil.

	Resistance	Knob position
Core – B/Y	0 – 1 Ω	x 1 Ω
Core – High tension	Approx. 15 k Ω	x k Ω
B/Y – High tension	Approx. 15 k Ω	x k Ω

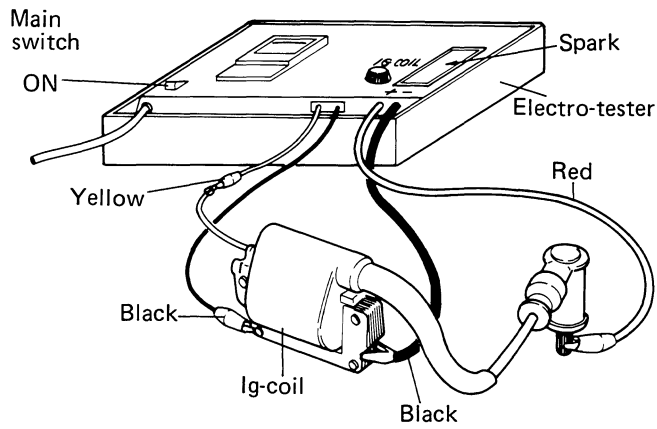
**Electro-tester****09900-28106**

- Wire as shown in the figure and turn the main switch to ON.
- If a bluish white spark occurs continuously for about ten minutes, it is in good condition. When a red spark, a poor spark or no spark is found, replace it.

PEI UNIT**PEI test lead for FZ50****09900-28605**

- Wire as shown in the figure and turn the main switch to ON.
- It is in good condition if the indicator light comes on and remains lit. If the light stays off, replace it.

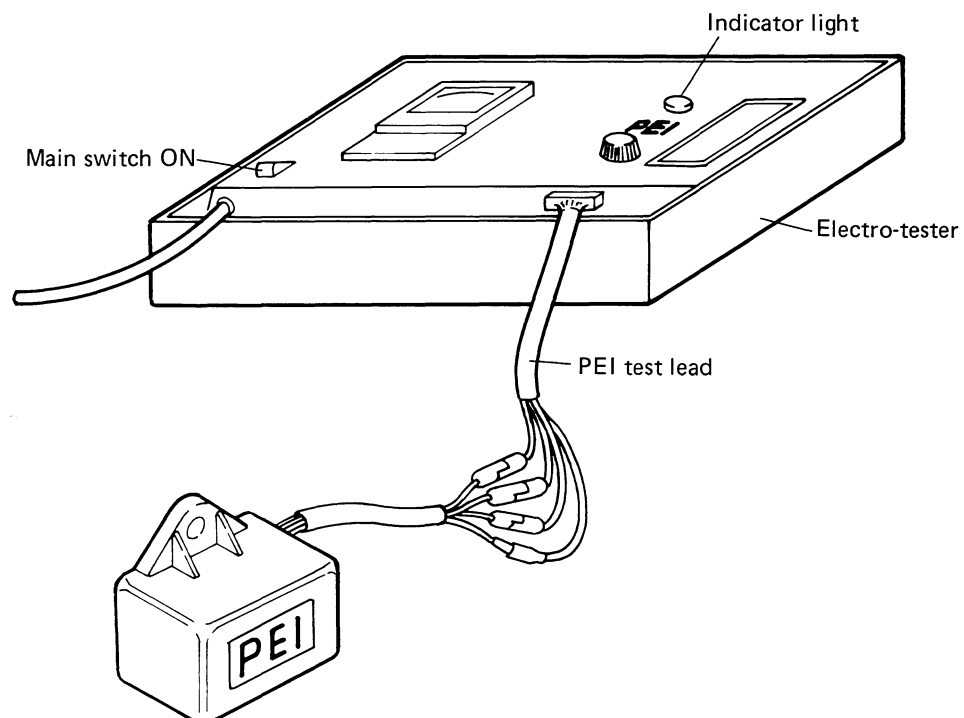

PEI Inspection by Pocket Tester

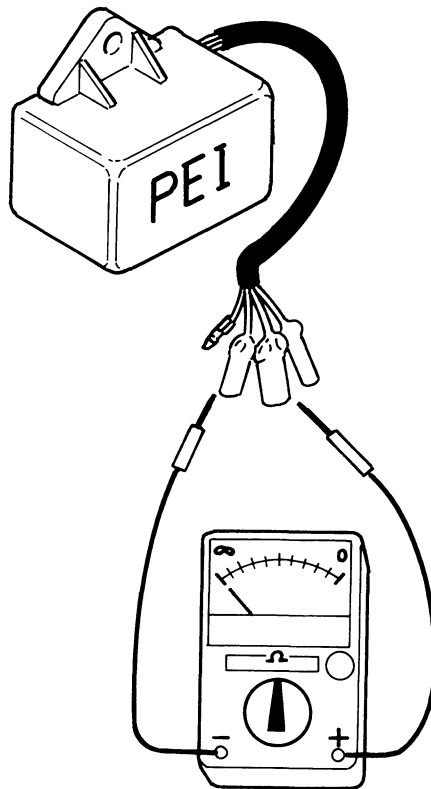

		Positive (+) pointer to touch:			
		Black/Red	Red/Black	Black/White	Black/Yellow
Negative (-) pointer touch:	Black/Red		OFF	OFF	OFF
	Red/Black	2 – 7 k Ω		0 – 20 k Ω	OFF
	Black/White	2 – 7 k Ω	0 – 20 Ω		OFF
	Black/Yellow	OFF	OFF	OFF	

Test conditions

- The pocket tester's selector knob should be set at "X 1 Ω " or "X 1 k Ω " range referring to the chart.
- The two testing probes, (+) and (-), are to be placed on terminals of the PEI unit referring to the chart.
- The (+) probe or pointer is to be placed on one of the terminals listed in the top horizontal row, and the (-) probe or pointer on the corresponding terminal listed in the vertical column.

NOTE:

- Whether or not the PEI unit is in good condition can be determined easily by temporarily replacing it with a new one.

RECTIFIER

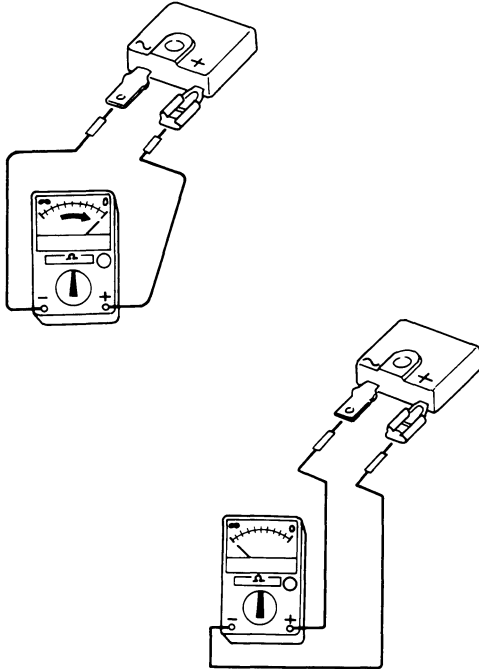

- If continuity is found in Ω range when connecting as shown in the figure and not found when (+) (-) probes are reversed, it is in good condition. If continuity is found in both cases or no continuity in either case, replace it.

HORN

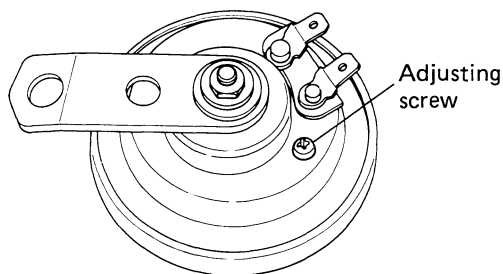

- If the sound volume is insufficient, turn the adjusting screw while connecting the horn directly to the battery till the maximum volume is found and set it there.
- After turning the adjusting screw, if no sound is heard or the sound volume is insufficient, replace it.

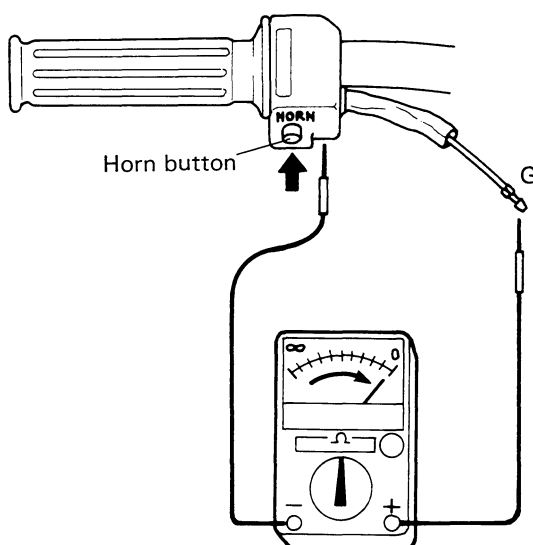

- Connect the lead wire in the headlight housing and the ground wire to the pocket tester, set knob range to R and press the horn button. If continuity is found, it is in good condition.

SWITCHES

IGNITION SWITCH

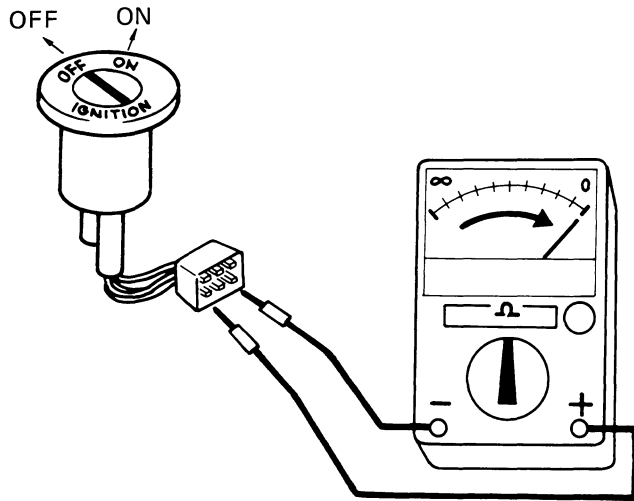

Pocket tester	09900-25002
---------------	-------------

- Turn the ignition switch to ON and OFF as shown in the chart below. If continuity is found, it is in good condition. If not, replace it.

	B/W	B/R	Gr	Y	O	R
OFF	○—○					
ON			○—○	○—○		

LEFT HANDLE SWITCH

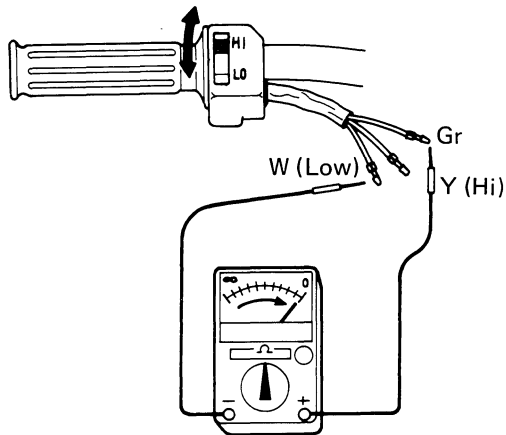

- Set it to high beam position and check continuity between gray and yellow. If continuity is found, it is in good condition.
- Set it to low beam position and check continuity between gray and white. If continuity is found, it is in good condition. If not, replace it.

ENGINE KILL SWITCH

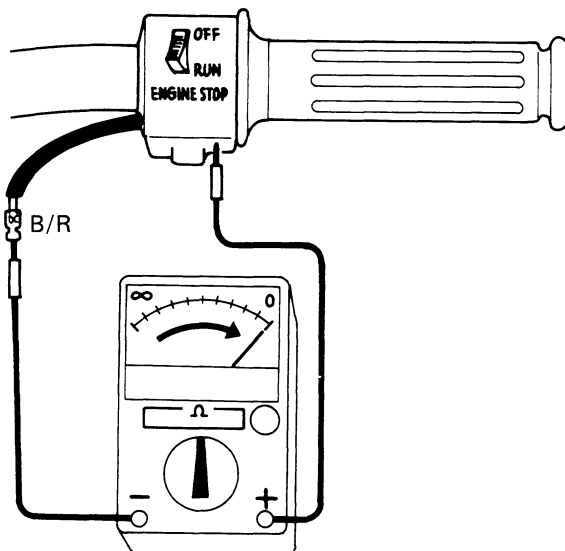

- Set the kill switch to OFF position, connect B/R wire and ground wire to the pocket tester and check continuity. If continuity is found, it is in good condition.
- When the kill switch is set to RUN position, if no continuity is found, it is in good condition.

FRONT AND REAR BRAKE SWITCH

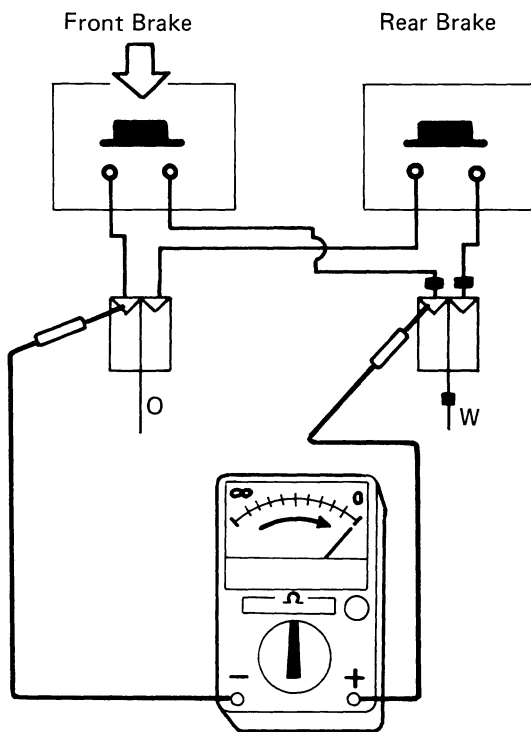

- Place the pocket tester between orange lead wire and white lead wire with the red tube and squeeze the brake lever. If continuity is found, it is in good condition. If not, replace it.

STEERING

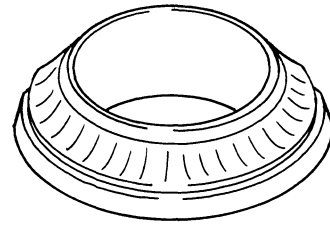
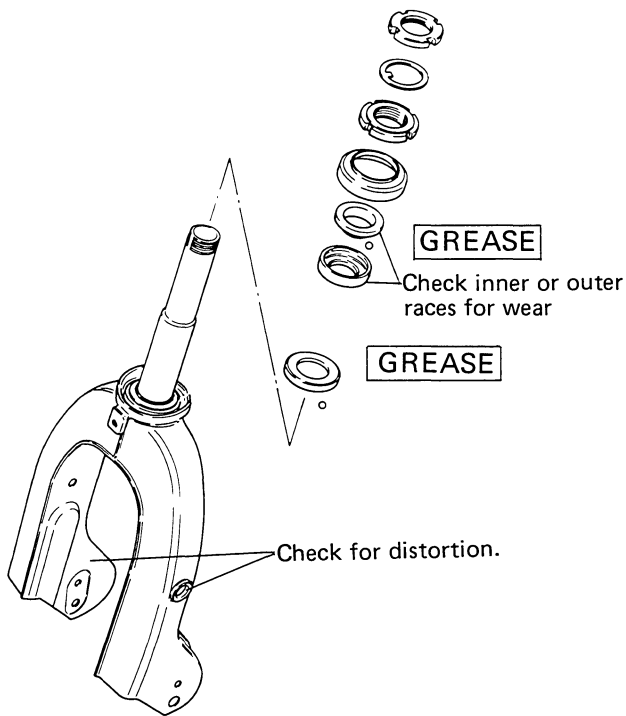

- Check inner or outer races for wear.

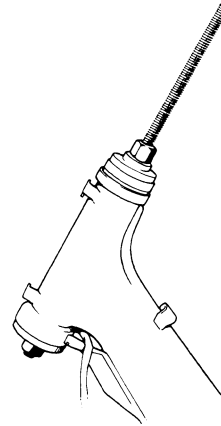

- Number of steel balls
Upper 22 pcs
Lower 25 pcs

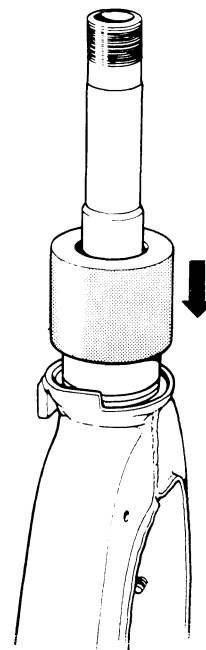
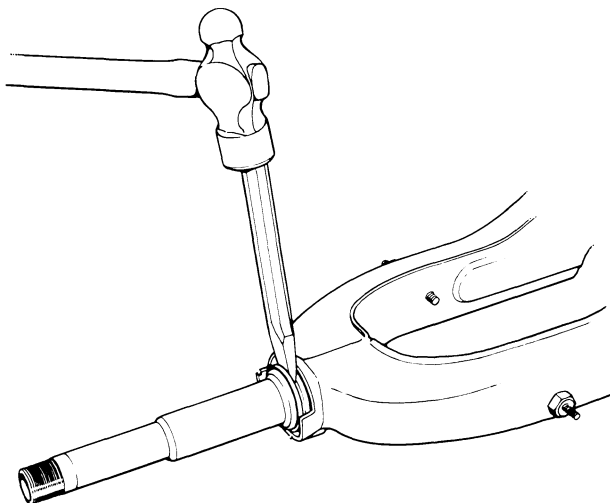

FRONT SUSPENSION

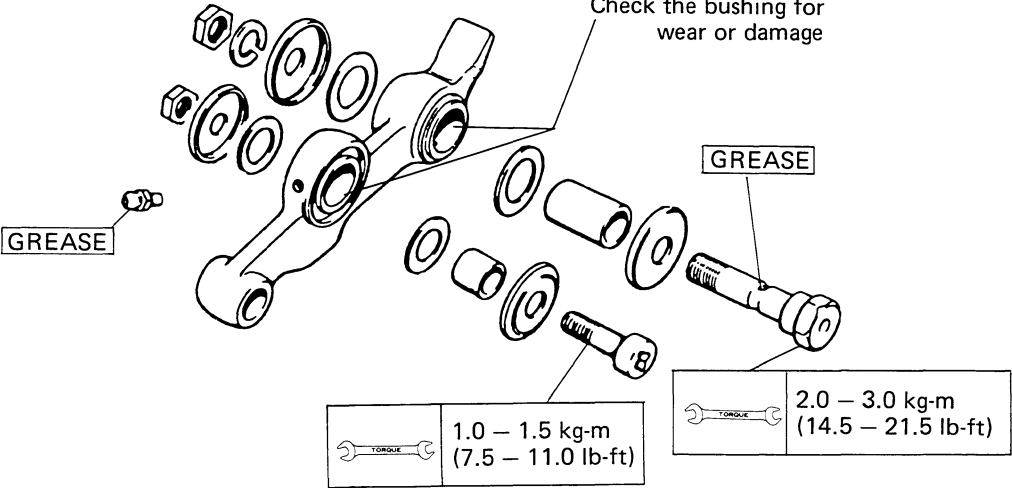
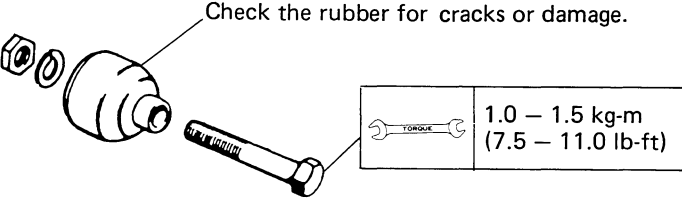
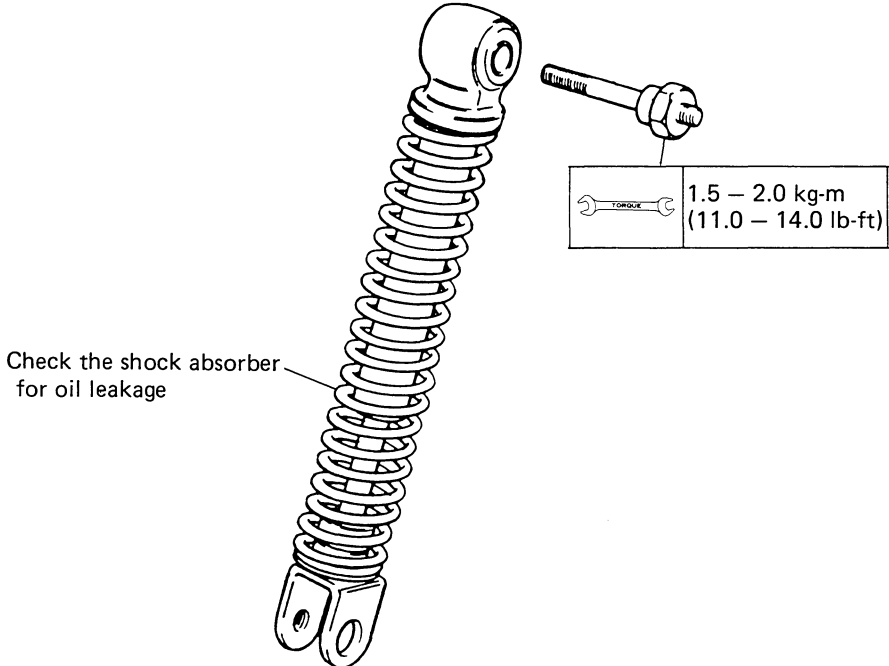

WHEELS AND BRAKES

WHEELS

FRONT

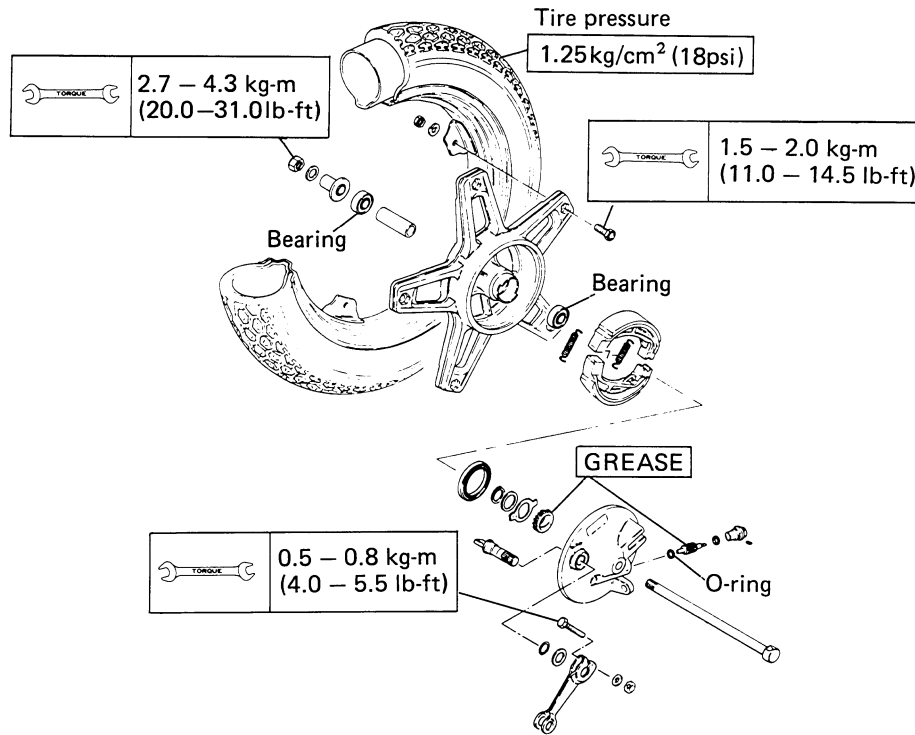

CAUTION:

When applying grease, be sure to apply it thin to avoid damaging the brake shoe and braking efficiency.

REAR

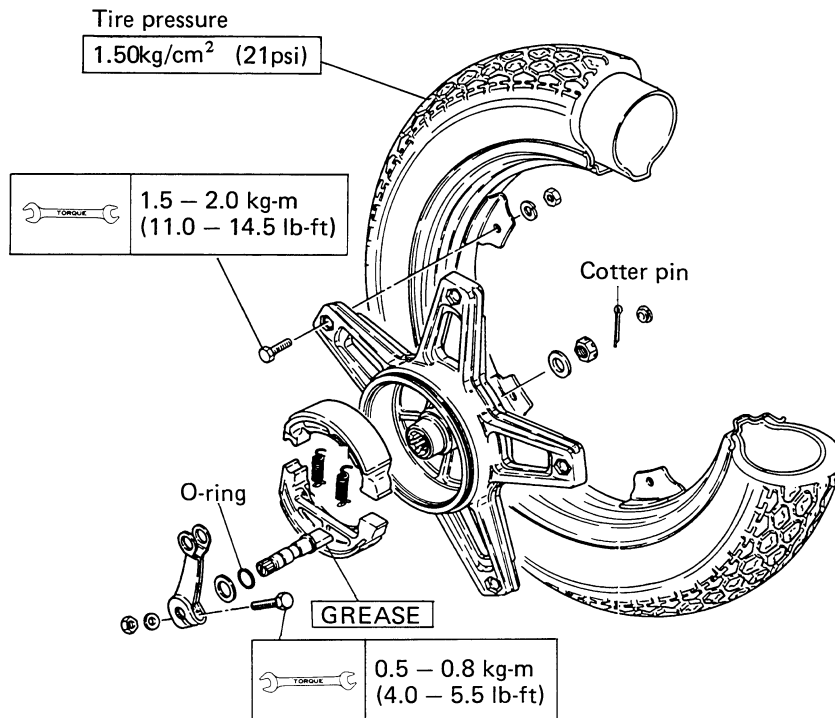

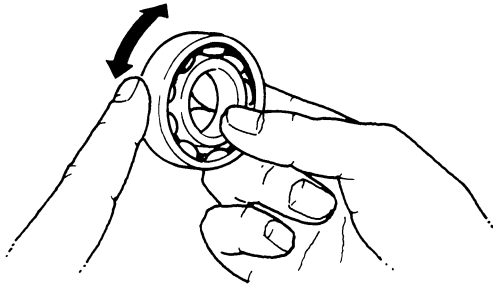

BEARING

Front wheel bearing is of grease sealed type and one side of it is sealed. If noise or excessive clearance is found when rotating it by hand, replace it.

As to the rear wheel bearing, both sides are sealed. If noise or excessive clearance is found between the inner race and the outer race or rotation is not smooth, replace it.

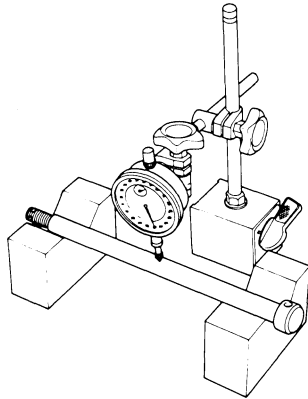

FRONT AXLE SHAFT

Measure the front axle shaft deflection.

Service limit	0.25 mm (0.01 in)
---------------	-------------------

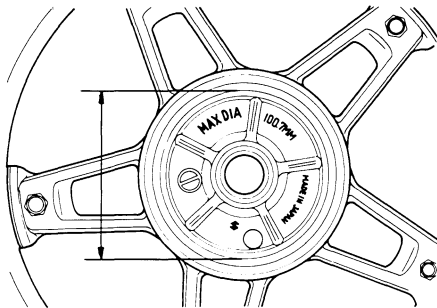

BRAKE DRUM

Measure inner diameter of both front and rear drums.

Service limit (Front and Rear)	100.7 mm (3.96 in)
-----------------------------------	--------------------

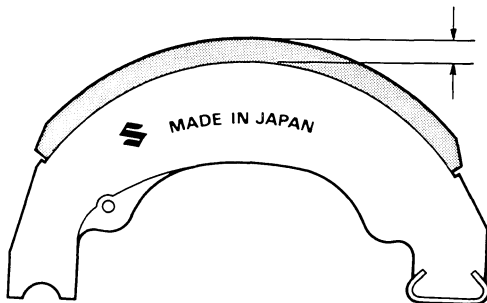

BRAKE LINING THICKNESS

Service limit	1.5 mm (0.06 in)
---------------	------------------

NOTE:

As an indicator is attached to the rear brake shoe, if it indicates the limit line, replace it.

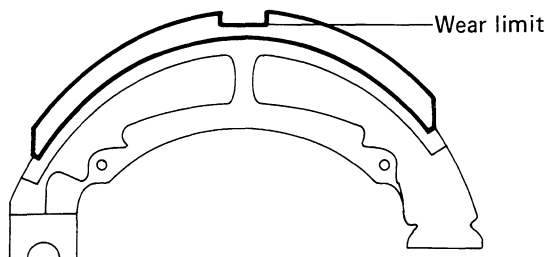

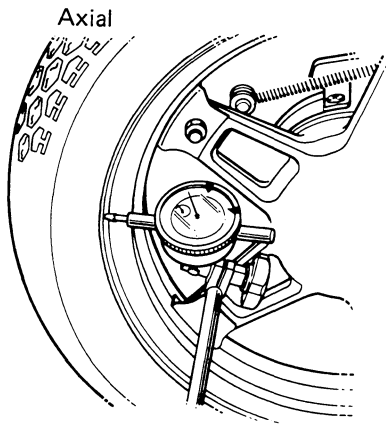

WHEEL RUNOUT

Measure axial and radial wheel rim runout of front and rear wheels.

Service limit (Axial and Radial)	2.0 mm (0.08 in)
-------------------------------------	------------------

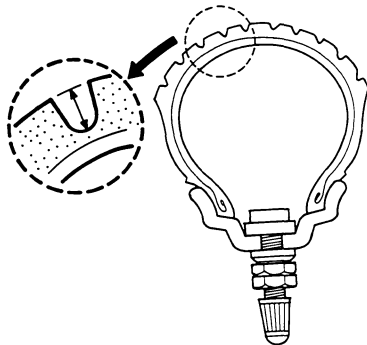
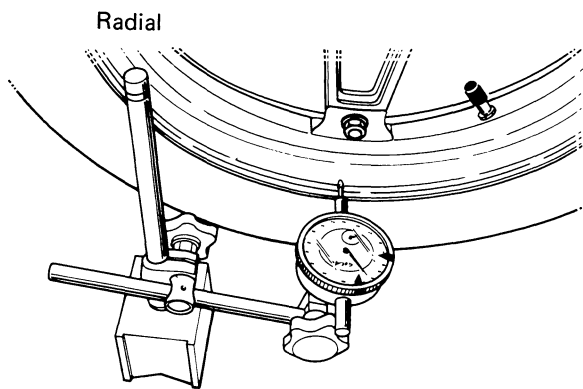

TIRE

Measure both front and rear tire tread depth.

Service limit (Front and Rear)	1.6 mm (0.063 in)
-----------------------------------	-------------------

SERVICING INFORMATION

CONTENTS

TROUBLESHOOTING	4- 2
SPECIAL MATERIALS	4- 5
SPECIAL TOOLS	4- 6
WIRE AND CABLE ROUTING.....	4- 8
WIRING DIAGRAM	4-10
TIGHTENING TORQUE.....	4-11
SERVICE DATA	4-12

TROUBLESHOOTING

HARD ENGINE STARTING OR NO ENGINE STARTING

ENGINE

1. Compression leakage from crank chamber
 - Leakage from crankcase mating surface
 - Leakage due to defective crankshaft oil seal
 - Leakage from cylinder base gasket
 - Damaged or improperly tightened reed valve
2. Compression leakage from combustion chamber
 - Loose spark plug mounting
 - Worn or sticking piston ring
 - Defective or warped cylinder head mating surface
 - Loose cylinder head tightening nut
 - Damaged cylinder head gasket
 - Piston seizure, wear or holed piston

FUEL CIRCUIT

1. Fuel line
 - Clogged fuel cock strainer
 - Damaged fuel cock diaphragm
 - Clogged fuel hose
2. Air passage
 - Clogged tank cap breather hole
 - Air intake due to defective fuel cock vacuum hose
 - Air intake due to damaged reed valve gasket
 - Air intake due to loose carburetor inlet mounting
3. Carburetor
 - Clogged needle valve
 - Clogged air jet or pilot jet
 - Poor return of choke plunger

ELECTRICAL CIRCUIT

1. No sparking at spark plug
 - Bridged, carbon fouled or wet spark plug
 - Broken or short circuited ignition coil
 - Broken or improperly connected engine ground wire
 - Defective engine kill switch
 - Defective PEI unit
 - Poor contact of ignition switch
 - Defective wiring among stator, PEI unit and ignition coil
 - Poor contact between spark plug cap and high tension cord
2. Sparking at spark plug
 - Improperly timed ignition
 - Loose mounting part of stator or rotor
 - Check engine unit or fuel circuit

ENGINE STALLING

1. Improper idling r/min.
2. Compression leakage from crankcase (oil seal, mating surface)
3. Fouled or worn spark plug
4. Lean fuel/air mixture
 - Clogged fuel hose
 - Clogged gasoline tank cap
 - Clogged carburetor jet
 - Incorrect carburetor fuel level
 - Air screw out of adjustment

NOT ENOUGH ENGINE POWER

1. Worn cylinder, piston or piston rings
2. Sticking piston ring
3. Defective spark plug gap
4. Clogged carburetor jet
5. Incorrect carburetor fuel level
6. Clogged air cleaner
7. Clogged exhaust muffler
8. Slipping clutch (see clutch slippage)

POOR ENGINE PERFORMANCE AT LOW-SPEED

1. Carburetor adjustment
 - Air screw adjustment
 - Idling r/min out of adjustment
 - Incorrect fuel level
2. Ignition system
 - Improperly timed ignition (improper stator mounting position)
 - Incorrect spark plug gap
3. Air cleaner element ripped or leaking
4. Air intake through inlet hose
5. Damaged reed valve

POOR ENGINE PERFORMANCE AT HIGH-SPEED

1. Clogged carburetor jet
2. Defective jet needle clip piston
3. Clogged air cleaner element
4. Improperly timed ignition (improper stator mounting position)
5. Defective ignition coil
6. Incorrect spark plug gap

ENGINE OVERHEAT

1. Carbon deposit
 - Cylinder head, piston crown, exhaust port, spark plug
2. Ignition timing too advance
3. Oil pump adjustment, defective oil pump
4. Lean fuel/air mixture
 - Carburetor float level
 - Clogged carburetor jet
5. Dragging brake



DEFECTIVE CLUTCH



1. Slipping clutch
 - Worn or burnt clutch shoe
2. Disengaged clutch
 - Poor operation of clutch drive shoe
3. Incorrect clutch-engagement r/min
 - Defective clutch spring
 - Worn or burnt clutch drive shoe
4. Not smooth idling
 - Defective clutch spring
 - Too high idling r/min.

SPECIAL MATERIALS

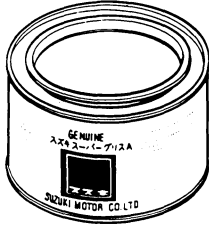
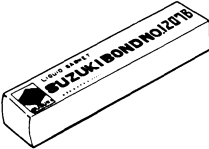
MATERIAL REQUIRED FOR MAINTENANCE

The materials listed below are required for maintenance works on the Model FZ50, and should be kept on hand for ready use. In addition, such standard materials as cleaning fluids, lubricants, etc., should also be available. Methods of use are discussed in the text of this manual.

Material	Use
 <p>Suzuki super grease "A" 99000-25030</p>	<ul style="list-style-type: none"> ○ Oil seals ○ Cable (speedometer) ○ Brake cam shaft ○ Speedometer gears ○ Front shock absorber arm and arm shaft
 <p>Suzuki bond No. 1207B 99104-31140</p>	<ul style="list-style-type: none"> ○ Crankcase mating surface
 <p>Thread lock "1342" 99000-32050</p>	<ul style="list-style-type: none"> ○ Muffler fitting bolt

 <p>Thread lock cement 99000-32040</p>	<ul style="list-style-type: none"> ○ Screws (securing read valve) ○ Crankshaft left end nut ○ Muffler clamp bolt ○ Horn adjusting screw ○ Cylinder stud bolts
 <p>Thread lock super "1303" 99000-32030</p>	<ul style="list-style-type: none"> ○ Crankshaft RH oil seal (to outer surface of oil seal) ○ Magneto rotor nut

USE OF GENUINE SUZUKI PARTS

To replace any part of the machine, use a genuine SUZUKI replacement part. Imitation parts or parts supplied from any other source than SUZUKI, if used to replace parts of SUZUKI origin in the machine, will lower the inherent capacity of the machine and, even worse, could induce costly mechanical trouble.

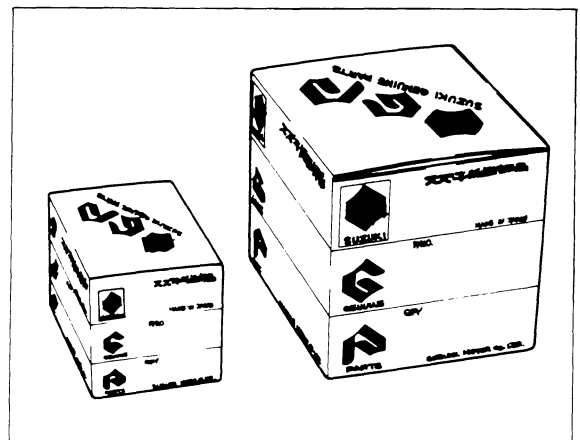

SPECIAL TOOLS

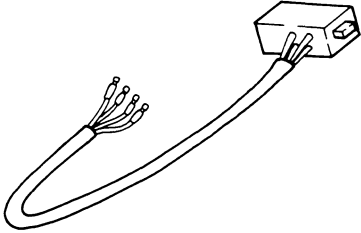
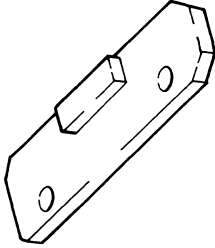
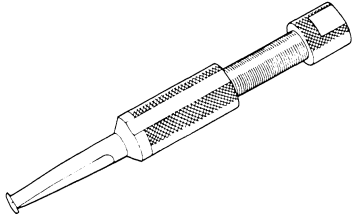
		
<p>PEI Test lead 09900-28605</p>	<p>Clutch holder 09920-30220</p>	<p>Bearing remover (ID 12mm) 09921-20210</p>

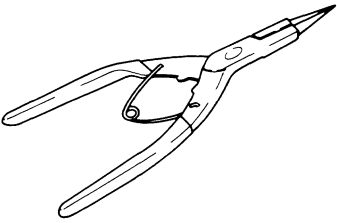
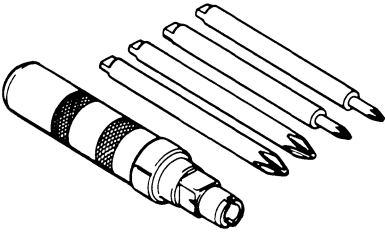
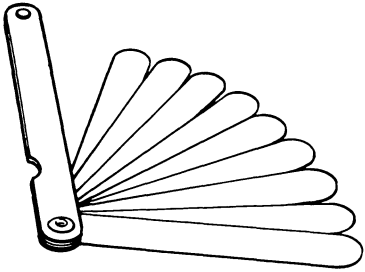
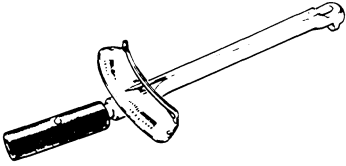
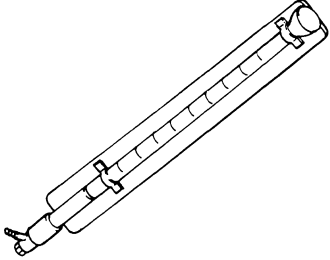
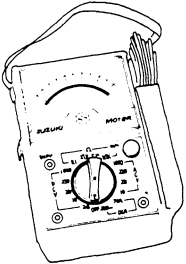
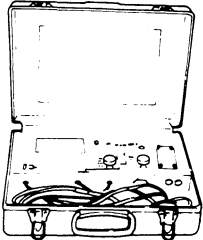
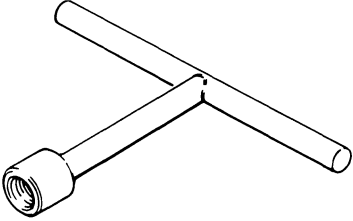
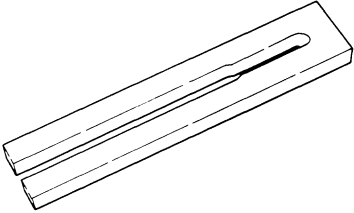
		
<p>Snap ring pliers 09900-06107</p>	<p>Impact driver set 09900-09003</p>	<p>Thickness gauge 09900-20803</p>
		
<p>Torque wrench 0 – 450 kg-m 09900-21101</p>	<p>CCI oil measuring tool 09900-21602</p>	<p>Pocket tester 09900-25002</p>
		
<p>Electro tester (SS-II) 09900-28106</p>	<p>6mm stud bolt installer 09910-10110</p>	<p>Con rod stopper 09910-20115</p>

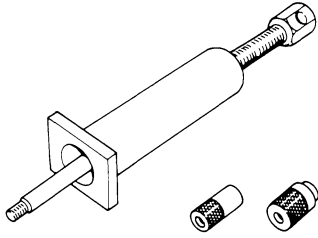
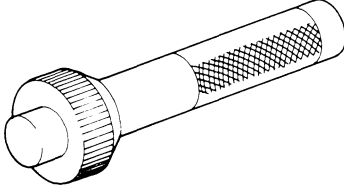
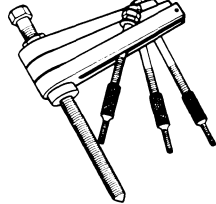
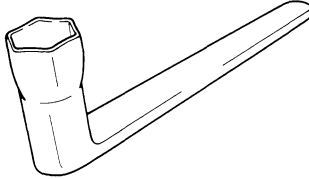
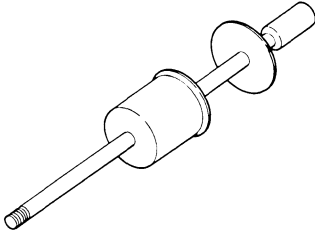
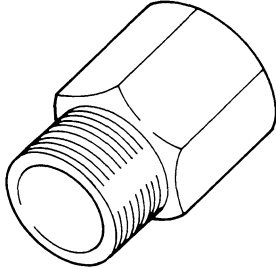
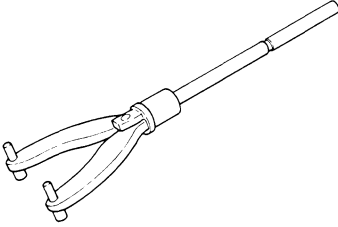
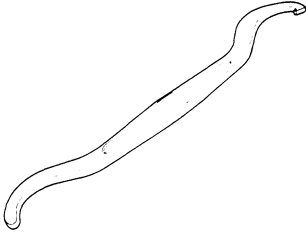
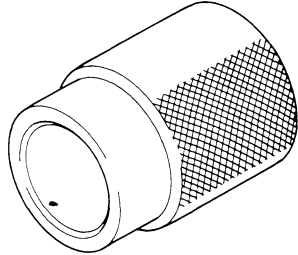
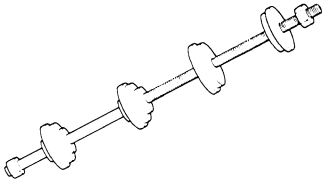
		
<p>Piston pin puller 09910-34510</p>	<p>Bearing installer 09913-75820</p>	<p>Crankshaft remover 09920-13120</p>
		
<p>Spark plug wrench 09930-10111</p>	<p>Rotor remover (shaft) 09930-30102</p>	<p>Attachment C (Screw 27mm) 09930-30161</p>
		
<p>Flywheel holder 09930-40113</p>	<p>Steering stem lock nut wrench 09940-10122</p>	<p>Steering race installer 09940-53111</p>
		
<p>Steering race installer 09941-34513</p>		

WIRE AND CABLE ROUTING

WIRING ROUTING

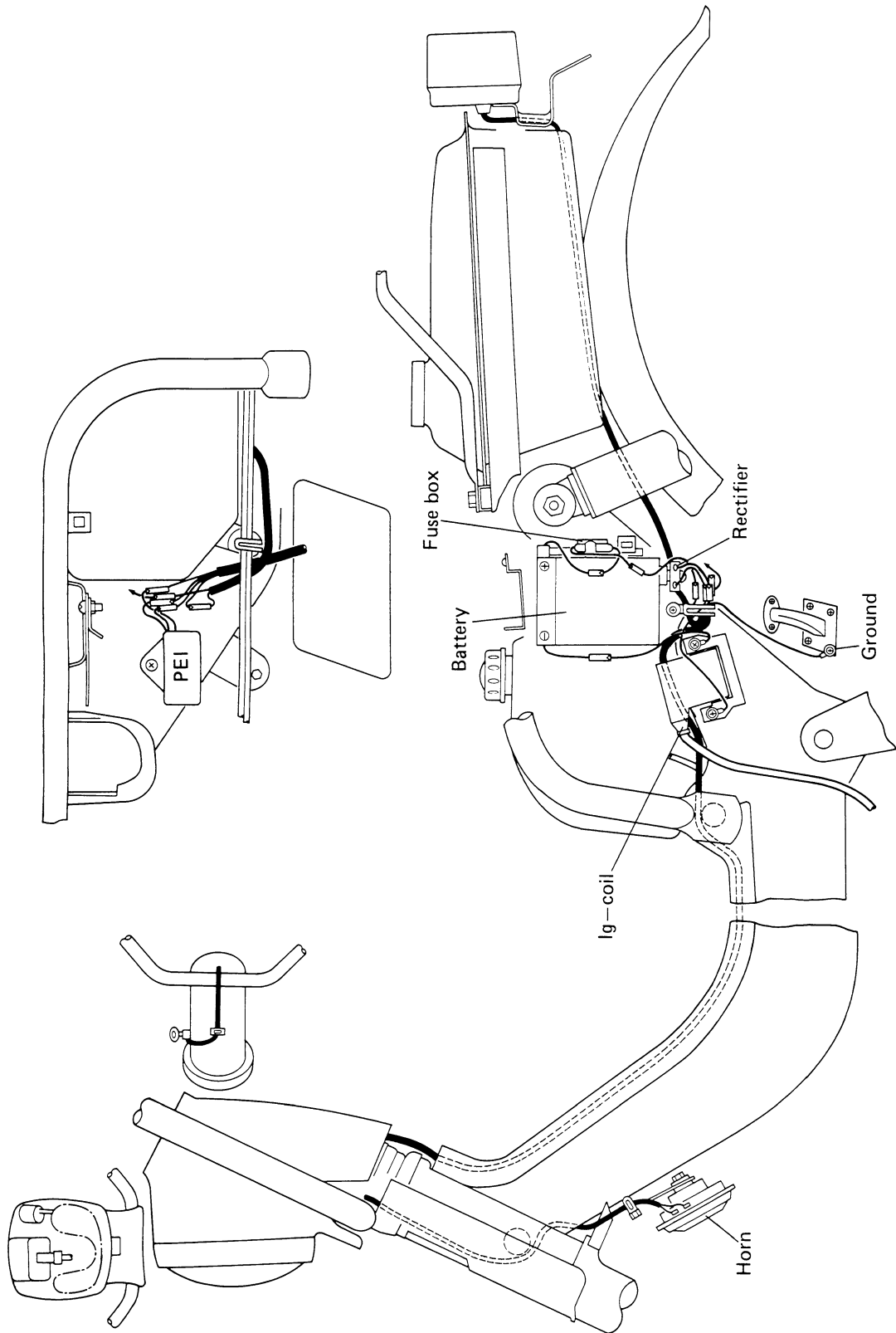

CABLE ROUTING

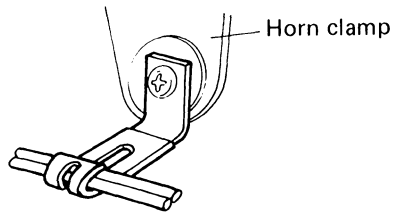
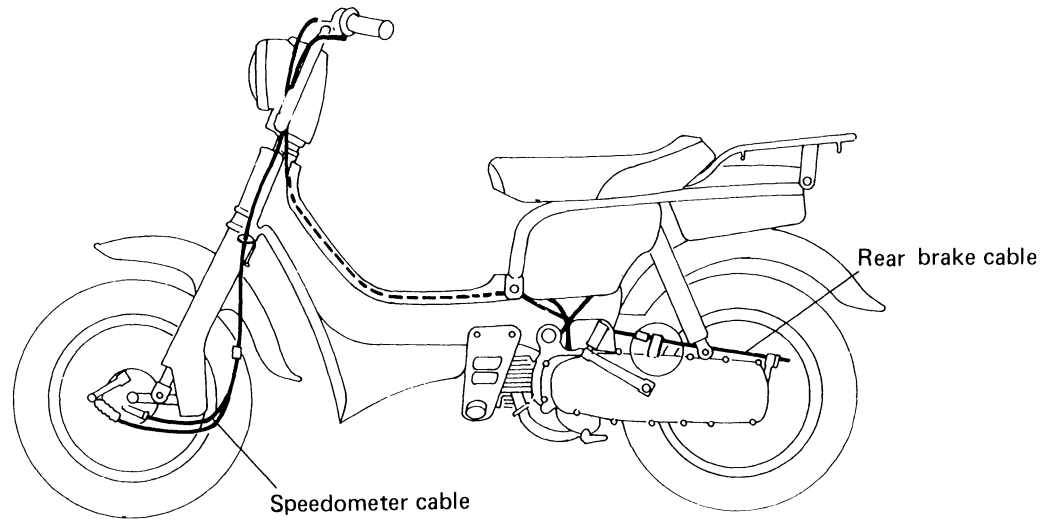
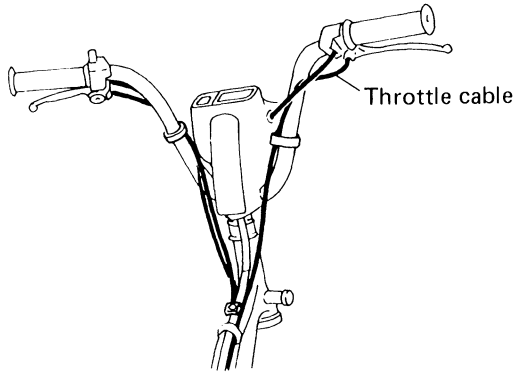
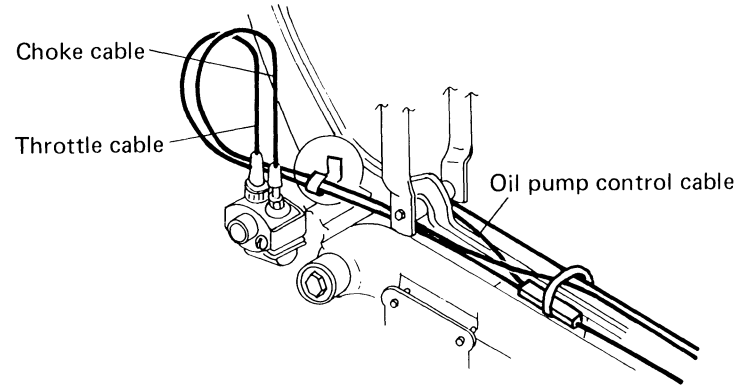
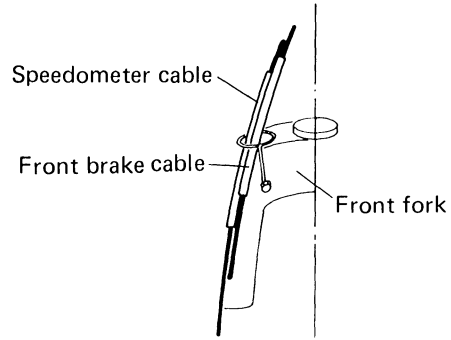
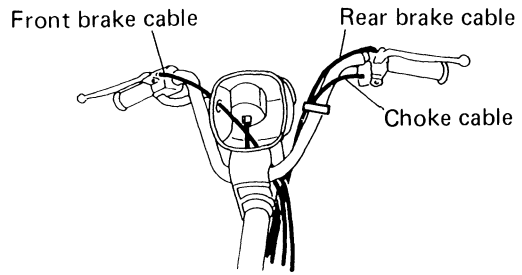

WIRING DIAGRAM

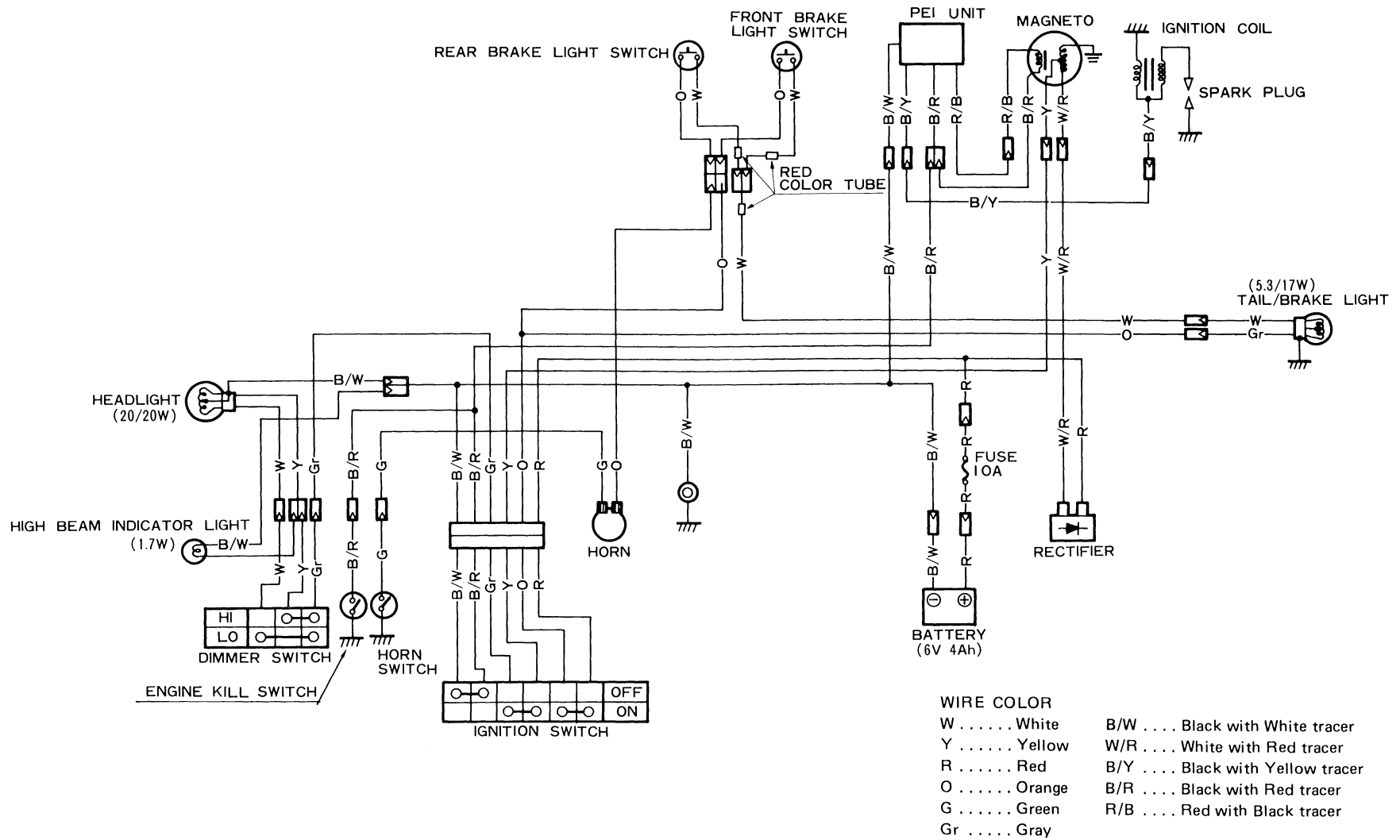

TIGHTENING TORQUE

ITEM	Q'TY	kg-m	lb-ft
------	------	------	-------

ENGINE

Cylinder head nut	4	0.8 – 1.2	6.0 – 8.5
Exhaust pipe bolt	2	1.5 – 2.0	11.0 – 14.0
Muffler bolt	1	1.5 – 2.0	11.0 – 14.0
Clutch nut	1	2.0 – 3.0	14.5 – 21.5
Kick starter lifter lever nut	1	0.5 – 0.8	4.0 – 5.5
Kick starter lever bolt	1	0.5 – 0.8	4.0 – 5.5
Flywheel magneto nut	1	3.0 – 3.5	22.0 – 25.5

CHASSIS

Front brake cam lever nut	1	0.5 – 0.8	4.0 – 5.5
Front suspension arm lower nut	2	1.0 – 1.5	7.5 – 10.5
Front suspension arm rear nut	2	2.0 – 3.0	14.5 – 21.5
Front suspension arm damper nut	2	1.0 – 1.5	7.5 – 10.5
Front shock absorber upper bolt	2	1.5 – 2.0	11.0 – 14.0
Rear shock absorber upper nut	1	2.0 – 3.0	14.5 – 21.5
Rear shock absorber lower bolt	1	2.0 – 3.0	14.5 – 21.5
Rear brake cam lever nut	1	0.5 – 0.8	4.0 – 5.5
Rear axle nut	1	3.6 – 5.2	26.5 – 37.5
Engine mounting nut	1	2.5 – 4.0	18.5 – 28.5
Front footrest nut	2	1.0 – 1.5	7.5 – 10.5
Handlebar expander bolt	1	5.0 – 6.5	36.5 – 47.0
Front axle nut	1	2.7 – 4.3	20.0 – 31.0

SERVICE DATA

PISTON + RING + CYLINDER

Unit : mm (in)

ITEM	STANDARD				LIMIT	
Piston – Cylinder clearance	0.070 – 0.080 (0.0028 – 0.0031)				0.120 (0.0047)	
Cylinder bore	41.000 – 41.015 (1.6142 – 1.6148) Measuring point: 15 (0.60) from the cylinder top surface				41.060 (1.6165)	
Piston dia./Measurement point	40.925 – 40.940 (1.6112 – 1.6118) Measuring point: at a piston height of 23 (0.90)				40.880 (1.6094)	
Cylinder warpage	–				0.05 (0.002)	
Cylinder head warpage	–				0.05 (0.002)	
Piston ring free end gap		TYPE	RIKEN (R)	TEIKOKU (T)	RIKEN (R)	TEIKOKU (T)
	1st	Keystone	4.5 (0.18)	5.0 (0.20)	3.6 (0.14)	4.0 (0.16)
	2nd	Keystone	4.5 (0.18)	5.0 (0.20)		
Piston ring end gap			RIKEN (R)	TEIKOKU (T)	0.75 (0.030)	
	1st & 2nd		0.10 – 0.25 (0.004 – 0.010)	0.10 – 0.25 (0.004 – 0.010)		
Piston ring width	1st	1.7 – 1.9 (0.067 – 0.075)				
	2nd	1.5 – 1.7 (0.059 – 0.067)				
Piston pin – Pin bore clearance	0.002 (tight) – 0.010 (0.0001 – 0.0004)				0.08 (0.0031)	
Piston pin bore I.D.	11.998 – 12.006 (0.4724 – 0.4727)				–	
Piston pin O.D.	11.996 – 12.000 (0.4723 – 0.4724)				11.980 (0.4717)	

CRANKSHAFT

Unit : mm (in)

ITEM	STANDARD	LIMIT
Con-rod small end bore	16.003 – 16.011 (0.6300 – 0.6304)	16.040 (0.6315)
Con-rod deflection (small end)	–	3.0 (0.12)
Con-rod big end wear	–	0.08 (0.003)
Crankshaft runout	–	0.05 (0.002)

OIL PUMP

ITEM	SPECIFICATION
Oil pump reduction ratio	7.000 (14/2)
CCI pump discharge rate (Full open)	1.02 – 1.26 mL (cc) 6 minutes at 2 000 r/min

CLUTCH

Unit : mm (in)

ITEM	STANDARD		LIMIT
Clutch wheel I.D.	Low	87.00 – 87.15 (3.425 – 3.431)	87.40 (3.441)
	2nd	105.00 – 105.15 (4.134 – 4.140)	105.50 (4.154)
Clutch shoe surface	Low	–	No groove at any part
	2nd	–	No groove at any part
Clutch spring free length	Low	–	Over 28.0 (1.06)
	2nd	–	Over 33.0 (1.30)
Clutch No. 1			
Engagement r/min	2 500 ±200 r/min		–
Lock up r/min	3 800 ±200 r/min		–
Clutch No. 2			
Gear shift point	21 ±2 km/h (13 ±1 mph)		–
Pri. drive – driven gear backlash	0 – 0.03 (0 – 0.0012)		0.1 (0.004)

TRANSMISSION

Unit : mm (in)

ITEM	STANDARD	LIMIT
Primary reduction	1.000	
Final reduction	8.696 (31/13 x 62/17)	
Gear ratios, Low	2.137 (62/29)	
2nd	1.421 (54/38)	
Gear backlash	0.05 – 0.10 (0.002 – 0.004)	0.15 (0.006)
Drive chain size	D.I.D. "270 H" 64 links	
20 pitch length	170.0 (6.69)	173.0 (6.83)

CARBURETOR

Unit : mm (in)

ITEM	SPECIFICATION
Idle r/min	1 500 ±150 r/min
Carburetor type	MIKUNI VM14SH
I.D. No.	02420
Bore size	14 mm (0.6 in)
Float height	22.4 ±1.0 (0.88 ±0.04)
Air screw	1¼ turns back
Throttle valve cut-away	2.0
Jet needle	3D13-3
Pilot jet	#15
Pilot outlet	0.9
Needle jet	E-2
Main jet	#57.5

ELECTRICAL

Unit : mm (in)

ITEM	SPECIFICATION
Ignition timing	20° B.T.D.C. at 4 000 r/min.
Spark plug	NGK BP-4HA or ND W14FP-UL
Spark plug gap	0.6 – 0.8 (0.024 – 0.031)
Ignition coil resistance (primary)	Approx. 0.5 Ω
Ignition coil resistance (secondary)	Approx. 15 kΩ
Magneto coil resistance (charge)	Y/R – W/R: Approx. 0.4 Ω
Magneto coil resistance (lighting)	Y/R – Ground: Approx. 0.2 Ω
Magneto coil resistance (primary)	B/R – R/B: Approx. 200 Ω
Battery capacity	YUASA or FURUKAWA make "6N4-2A" 6V 14.4kC (4Ah)/10HR
Specific gravity	1.26 at 20°C (68°F)
Fuse size	10A
Lighting coil output	Above 5.2V at 2 500 r/min, Below 8.5V at 8 000 r/min

BRAKE + WHEEL

Unit : mm (in)

ITEM	STANDARD	LIMIT
Axle runout (Front & Rear)	—	0.25 (0.010)
Brake drum I.D.	Front: 100 (3.94)	100.7 (3.96)
	Rear: 100 (3.94)	100.7 (3.96)
Brake lining thickness (Front & Rear)	—	1.5 (0.06)
Wheel rim runout (Radial & Axial)	—	2.0 (0.08)
Tire size	Front: 3.00 – 12 – 4PR	
	Rear: 3.00 – 12 – 4PR	
Tire Tread depth	Front: —	1.6 (0.06)
	Rear: —	1.6 (0.06)

TIRE AIR PRESSURE

FRONT	REAR
125 kPa (1.25 kg/cm ² , 18 psi)	150 kPa (1.50 kg/cm ² , 21 psi)

SUSPENSION

Unit : mm (in)

ITEM	STANDARD	LIMIT
Front wheel travel	78 (3.1)	
Rear wheel travel	82 (3.2)	
Engine mounting pivot shaft runout	—	0.6 (0.024)

CAPACITY

Unit : mm (in)

ITEM	SPECIFICATION
Fuel tank including reserve	4.5 L (1.2/1.0 US/Imp gal)
reserve	0.9 L (0.24/0.20 US/Imp gal)
Engine oil tank	1.2 L (1.27/1.06 US/Imp qt)
Transmission oil	Change: 800 ml (800 cc, 0.85/0.70 US/Imp qt)
	Overhaul: 850 ml (850 cc, 0.90/0.75 US/Imp qt)
Fuel type	Unleaded or low-leaded gasoline
Engine oil type	SUZUKI CCI SUPER 2-CYCLE MOTOR LUBRICANT or equivalent good synthetic based 2-cycle oil
Transmission oil type	Good quality SAE 20W/40 multi-grade motor oil

FZ50“T” AND FZ50“X”

FOREWORD

The FZ50 “T” model was introduced as a new model in 1980. Many innovative refinements were incorporated in the new model. The 1981 FZ50 “X” model utilizes the same technical innovations that were introduced on the “T” model. This supplementary service manual has been produced to aid Suzuki mechanics in properly maintaining and repairing both the 1980 “T” and 1981 “X” models.

This manual has been written primarily for the experienced Suzuki mechanic but will also be very useful even for the amateur, do-it-yourself mechanic. The entire manual should be thoroughly reviewed before any servicing is performed.

Please also refer to the FZ50 “N” MODEL (1979 MODEL) Service Manual for all other areas of information not covered in this publication.

CONTENTS

VIEW OF SUZUKI FZ50“T”	5- 2
SPECIFICATIONS	5- 3
TRANSMISSION OIL	5- 5
“PEI” SYSTEM	5- 6
FLYWHEEL MAGNETO	5- 7
CHASSIS ELECTRICAL	5- 8
SPECIAL MATERIALS	5-11
SPECIAL TOOLS	5-12
WIRE AND CABLE ROUTING.....	5-14
WIRING DIAGRAM	5-16
SERVICE DATA	5-17
VIEW OF SUZUKI FZ50“X”	5-23
IGNITION COIL	5-24
TURN SIGNAL LIGHT SWITCH.....	5-24
WIRING DIAGRAM	5-25
SERVICE DATA	5-26



VIEW OF SUZUKI FZ50“T”

RIGHT SIDE VIEW

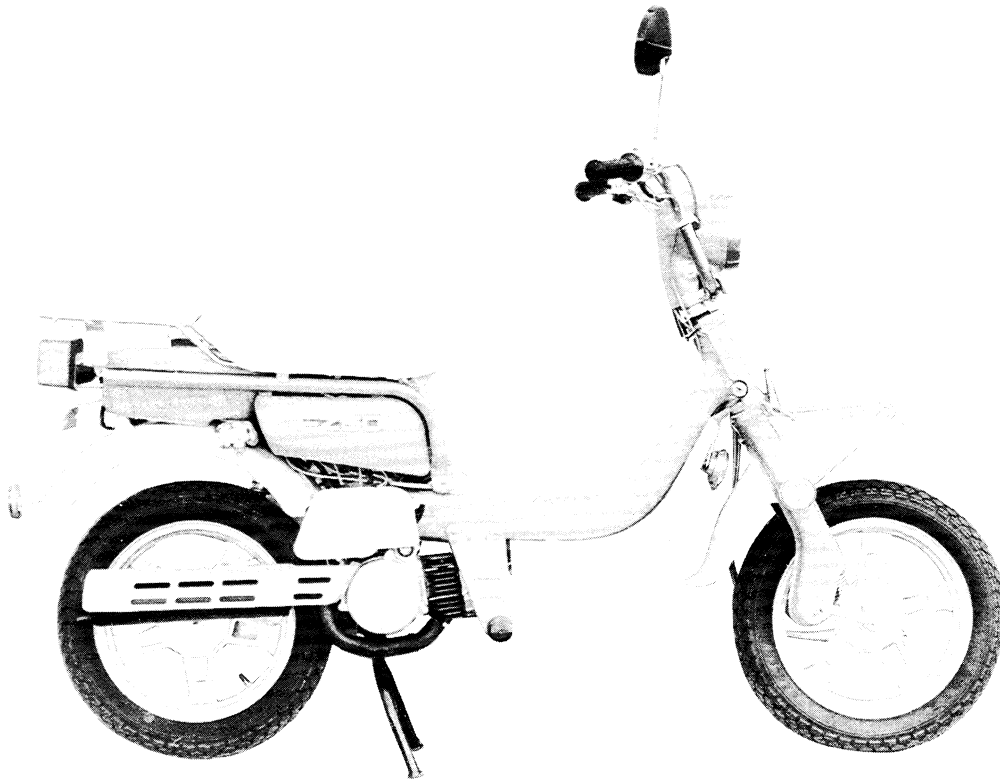

LEFT SIDE VIEW

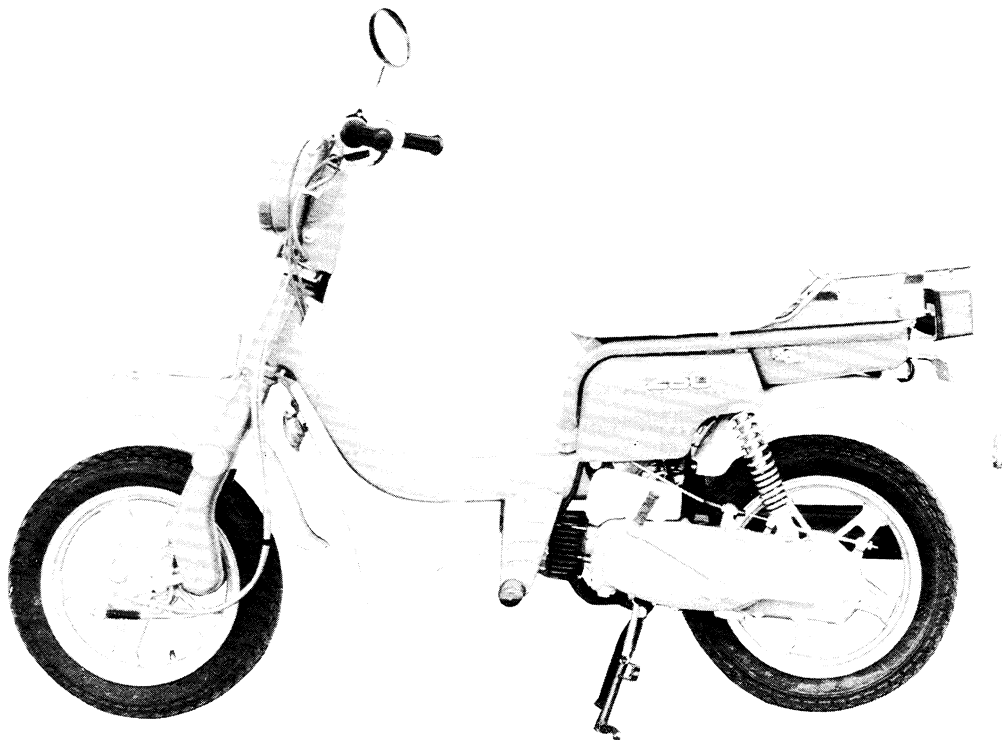

SPECIFICATIONS

DIMENSIONS AND WEIGHT

Overall length	1 650 mm (65.0 in)
Overall width	665 mm (26.2 in)
Overall height	990 mm (39.0 in)
Wheelbase	1 120 mm (44.1 in)
Ground clearance	120 mm (4.7 in)
Dry mass (weight)	59 kg (130 lbs)

ENGINE

Type	Two-stroke, air cooled
Intake system	Reed valve
Number of cylinder	1
Bore	41.0 mm (1.614 in)
Stroke	37.4 mm (1.472 in)
Piston displacement	49 cm ³ (3.0 cu.in)
Corrected compression ratio	6.1 : 1
Carburetor	MIKUNI VM14SH, single
Air cleaner	Polyurethane foam element
Starter system	Primary kick
Lubrication system	SUZUKI “CCI”

TRANSMISSION

Clutch	Wet shoe, automatic, centrifugal type
Transmission	2-speed
Gearshift pattern	Automatic type
Primary reduction	1.000
Final reduction	8.696
	(chain)
	2.384 (31/13)
	(gear)
	3.647 (62/17)
Gear ratios, Low	2.137 (62/29)
	2nd
	1.421 (54/38)
Drive chain	DAIDO D.I.D. 270H, 64 links

CHASSIS

Front suspension	Bottom link oil dampened
Rear suspension	Swinging arm
Steering angle	45° (right & left)
Caster	63° 00''
Trail	81 mm (3.19 in)
Turning radius	1.7 m (5.6 ft)
Front brake	Internal expanding
Rear brake	Internal expanding
Front tire size	3.00-12 4PR
Rear tire size	3.00-12 4PR
Front tire pressure	125 kPa (1.25 kg/cm ² , 18 psi) (Normal solo riding)
Rear tire pressure	150 kPa (1.50 kg/cm ² , 21 psi) (Normal solo riding)

ELECTRICAL

Ignition type	SUZUKI "PEI"
Ignition timing	25° B.T.D.C. at 4 000 r/min
Spark plug	NGK BP4HA or NIPPON DENSO W14FP-UL
Battery	6V 14.4 kC (4 Ah)/10 HR
Generator	Flywheel magneto
Fuse	10A

CAPACITIES

Fuel tank including reserve reserve	4.5 L (1.2 US gal) 0.2 L (0.2 US qt)
Engine oil tank	1.2 L (1.27 US qt)
Transmission oil	800 ml (0.85 US qt)

* These specifications are subject to change without notice.

TRANSMISSION OIL

Use a good quality SAE 20W/40 multi-grade motor oil.

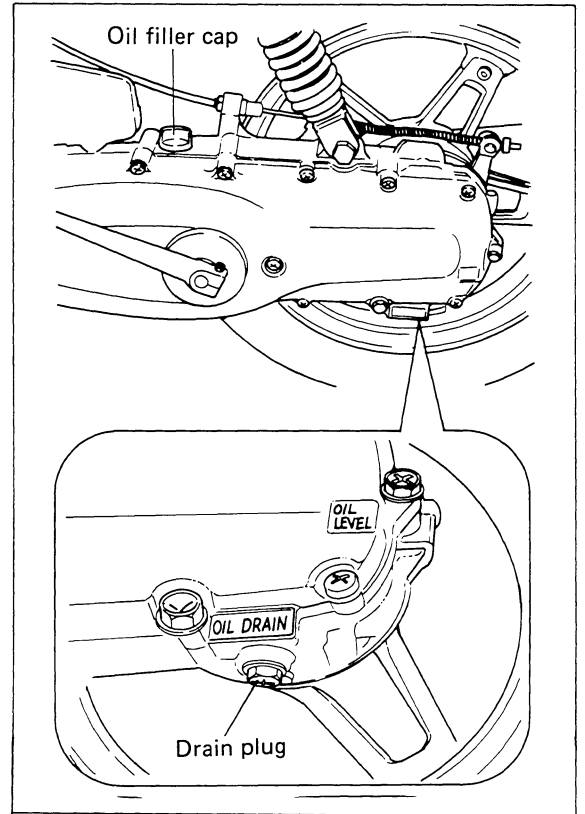

"PEI" SYSTEM

In the FZ50 ignition system, the PEI system is used.

The PEI system uses a magneto as the power source, and the capacitor (condenser) momentarily stores a charge up to hundreds of volts.

The charge is instantly discharged, at the specified ignition timing, to the ignition coil primary winding, thus inducing a high surge of voltage in the secondary winding. As a result, a spark occurs at the spark plug gap.

The PEI magneto has no breaker points and therefore it is free from mechanical trouble. This ensures a stabler secondary high voltage and better spark performance.

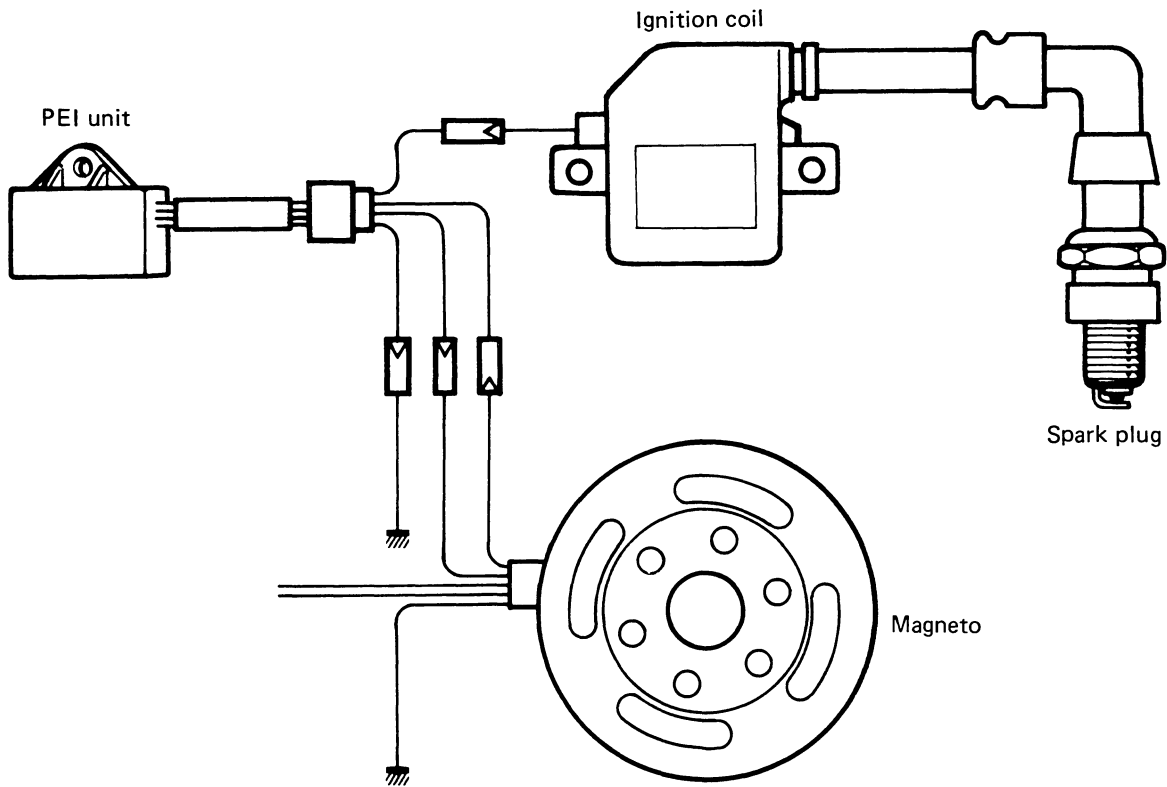

CONNECTING DIAGRAM

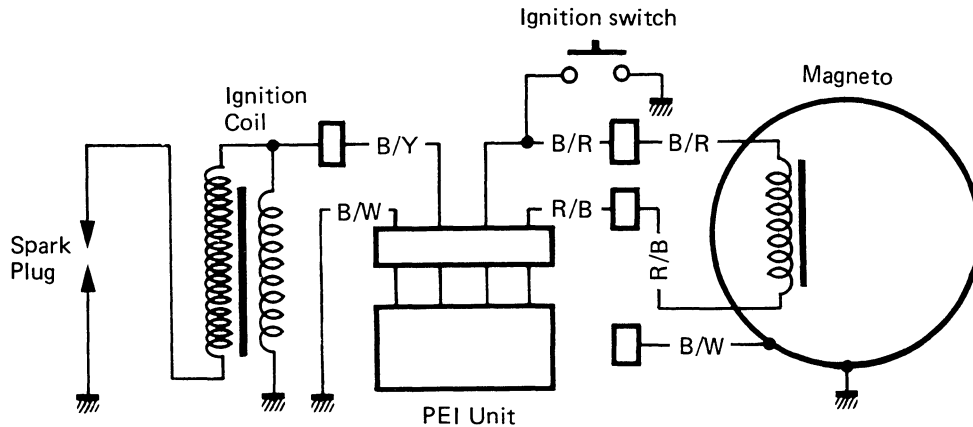

FLYWHEEL MAGNETO

SPECIFICATIONS

- Ignition method: 2 sparks per crankshaft rotation
- Light capacity: 5.5 V or more at 2 500 r/min
8.5 V or less at 8 000 r/min
- Charging capacity: 0.7 A or more at 4 000 r/min
3.0 A or less at 8 000 r/min
- Secondary voltage: 12 kV or more at 500 – 8 000 r/min
- Ignition coil resistance: Primary Approx. 0 – 1 Ω
Secondary Approx. 15 – 17 kΩ

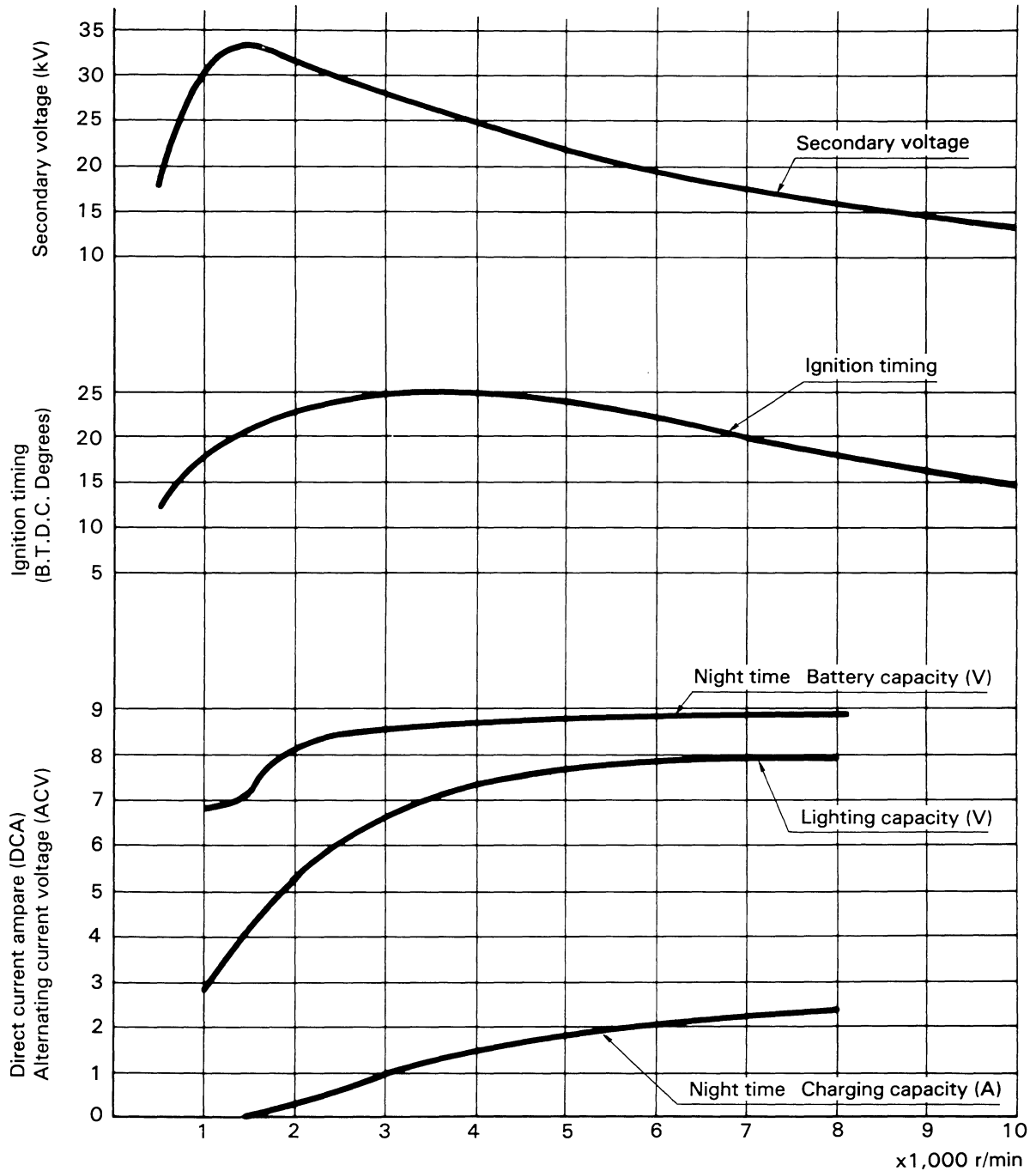

STATOR

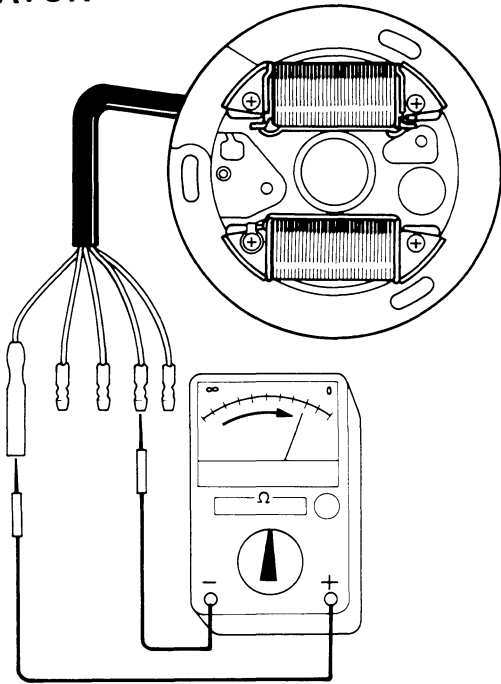

Pocket tester	09900-25002
---------------	-------------

- Select the knob to RX “x 1”.
- Make a following continuity test.

Unit : Approx. (Ω)

COLOR CODE	APPROX. (Ω)
B/W – Y	0.4
B/W – W/R	0.75
B/R – R/B	230

CHASSIS ELECTRICAL

IGNITION COIL

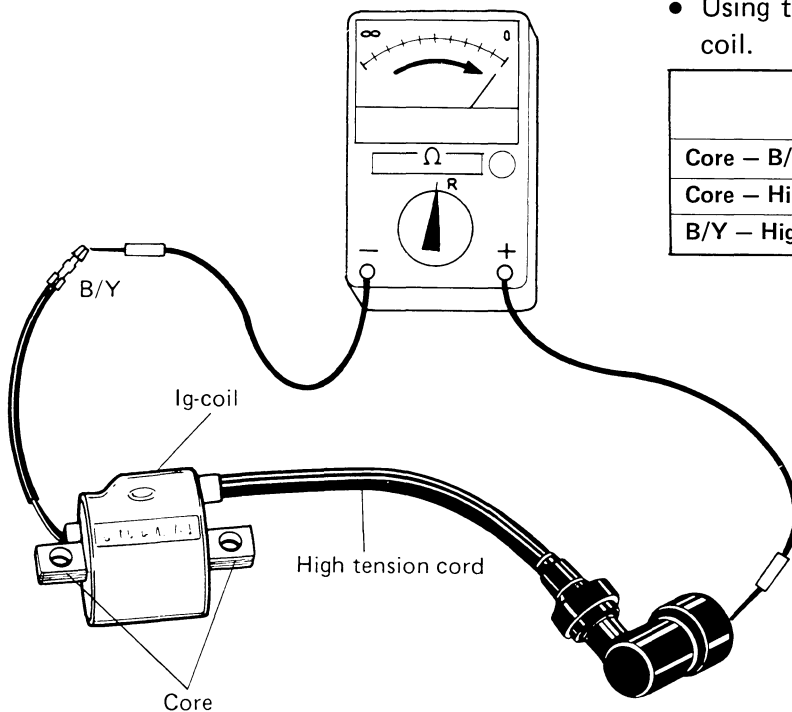

- Using the pocket tester check the ignition coil.

	Resistance	Knob position
Core – B/Y	0 – 1Ω	x 1Ω
Core – High tension	Approx. 15-17 kΩ	x kΩ
B/Y – High tension	Approx. 15-17 kΩ	x kΩ

“PEI” UNIT

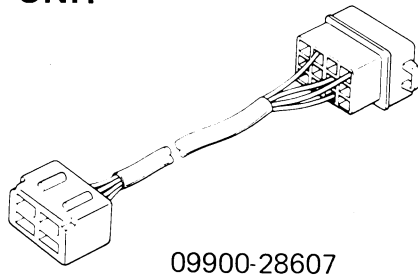

PEI test lead (coupler type)	09900-28607
------------------------------	-------------

- Wire as shown in the figure and turn the main switch to ON.
- It is in good condition if the indicator light comes on and remains lit. If the light stays off, replace it.

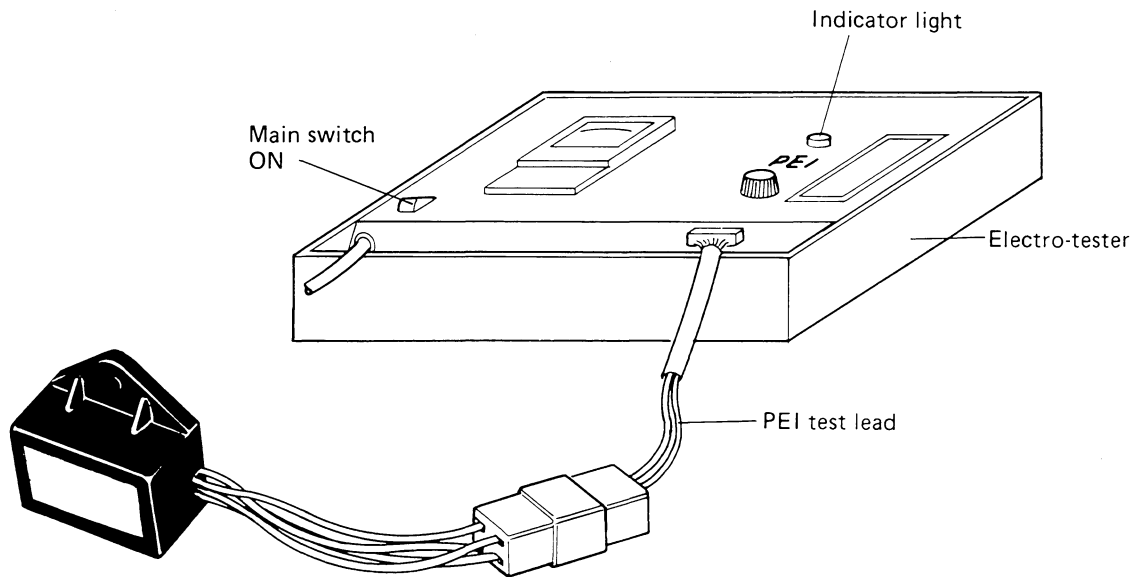

PEI Inspection by Pocket Tester

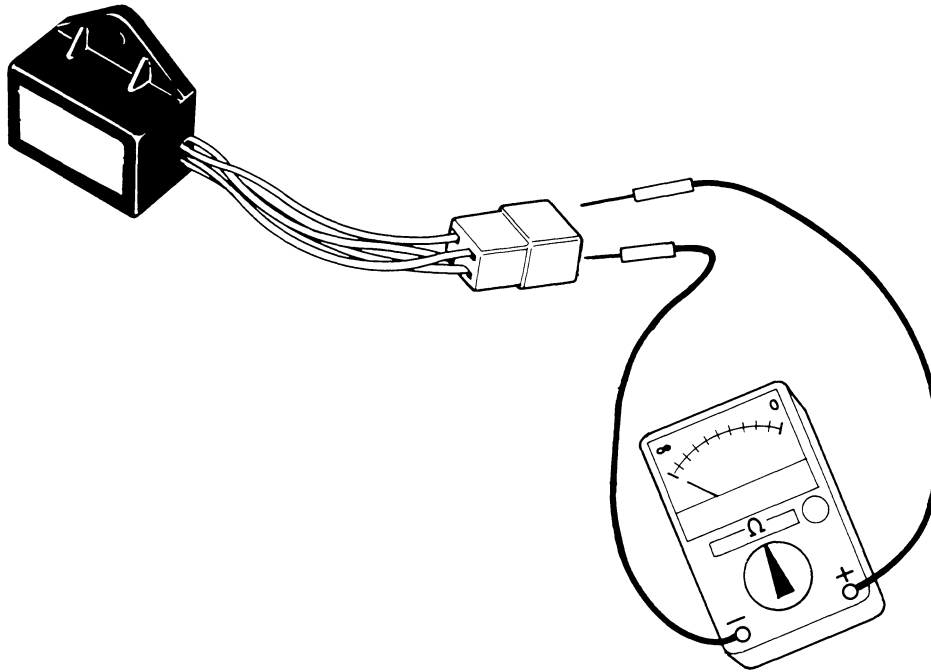

		Positive (+) pointer to touch:			
		Black/White	Black/Yellow	Black/Red	Red/Black
Negative (-) pointer to touch:	Black/White		OFF	5 – 7 Ω	4 – 6 Ω
	Black/Yellow	OFF		OFF	OFF
	Black/Red	4 – 6 Ω	OFF		OFF
	Red/Black	OFF	OFF	15 – 17 Ω	

Test conditions

- The pocket tester’s selector knob should be set at “X 1Ω” or “X 1 kΩ” range referring to the chart.
- The two testing probes, (+) and (-), are to be placed on terminals of the PEI unit referring to the chart.
- The (+) probe or pointer is to be placed on one of the terminals listed in the top horizontal row, and the (-) probe or pointer on the corresponding terminal listed in the vertical column.



NOTE:



- Whether or not the PEI unit is in good condition can be determined easily by temporarily replacing it with a new one.

SPECIAL MATERIALS

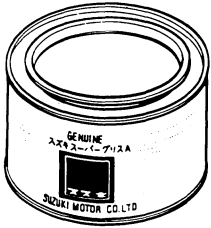
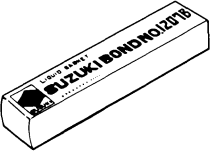
MATERIAL REQUIRED FOR MAINTENANCE

The materials listed below are required for maintenance works on the Model FZ50, and should be kept on hand for ready use. In addition, such standard materials as cleaning fluids, lubricants, etc., should also be available. Methods of use are discussed in the text of this manual.

Material	Use
 <p>Suzuki super grease “A” 99000-25030</p>	<ul style="list-style-type: none"> ○ Oil seals ○ Cable (speedometer) ○ Brake cam shaft ○ Speedometer gears ○ Front shock absorber arm and arm shaft
 <p>Suzuki bond No. 1207B 99104-31140</p>	<ul style="list-style-type: none"> ○ Crankcase mating surface
 <p>Thread lock “1342” 99000-32050</p>	<ul style="list-style-type: none"> ○ Muffler fitting bolt

 <p>Thread lock cement 99000-32040</p>	<ul style="list-style-type: none"> ○ Screws (securing read valve) ○ Crankshaft left end nut ○ Muffler clamp bolt ○ Horn adjusting screw ○ Cylinder stud bolts
 <p>Thread lock super “1303” 99000-32030</p>	<ul style="list-style-type: none"> ○ Crankshaft RH oil seal (to outer surface of oil seal) ○ Magneto rotor nut

SPECIAL TOOLS

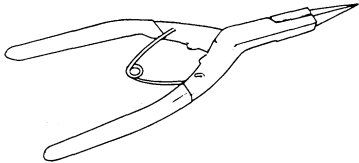
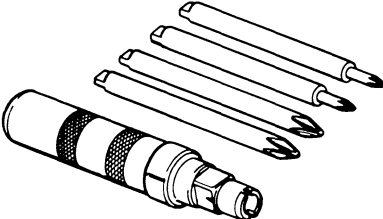
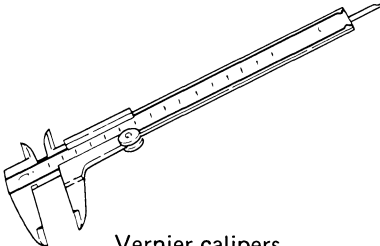
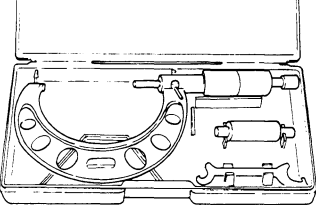
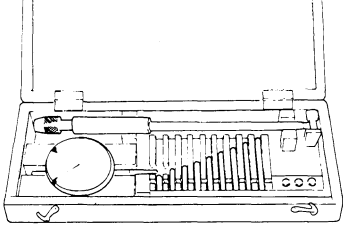
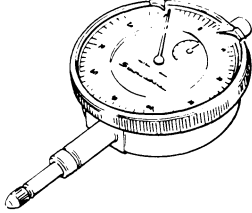
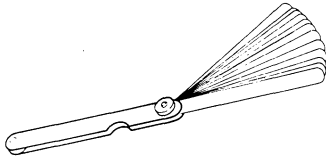
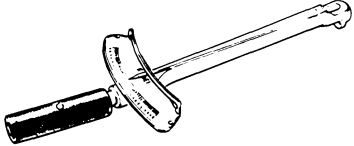
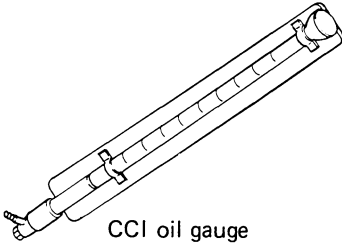
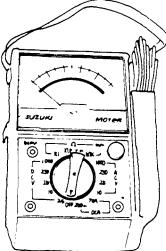
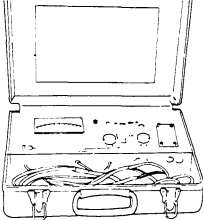
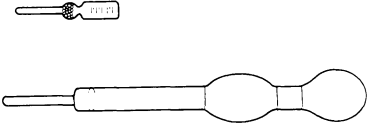
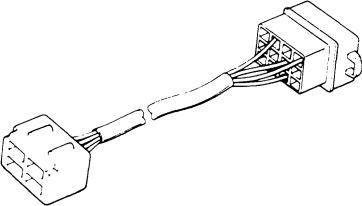
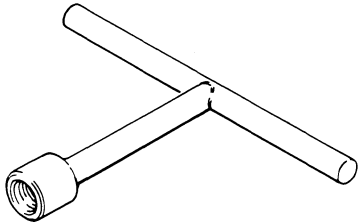
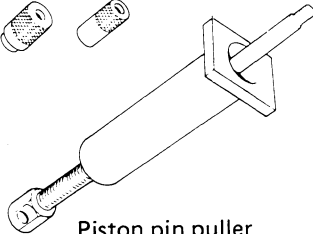
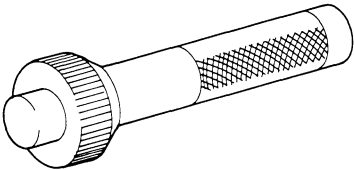
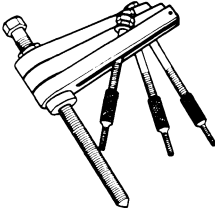
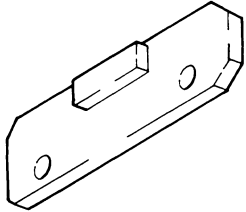
 <p>Snap ring pliers (opening type) 09900-06107</p>	 <p>Impact driver set 09900-09003</p>	 <p>Vernier calipers 09900-20101</p>
 <p>Micrometer 09900-20205 (0 ~ 25 mm) 09900-20202 (25 ~ 50 mm)</p>	 <p>Cylinder gauge set 09900-20508</p>	 <p>Dial gauge 09900-20606 (0 ~ 10 mm, $\frac{1}{100}$ mm)</p>
 <p>Thickness gauge 09900-20803</p>	 <p>Torque wrench 09009-21102 (0 ~ 120 kg-cm) 09900-21103 (100 ~ 900 kg-cm)</p>	 <p>CCI oil gauge 09900-21602</p>
 <p>Pocket tester 09900-25002</p>	 <p>Electro-tester 09900-28106</p>	 <p>Hydrometer 09900-28403</p>
 <p>PEI test lead 09900-28607</p>	 <p>Stud bolt installer 09910-10110</p>	 <p>Piston pin puller 09910-34510</p>
 <p>Bearing installer 09913-75820</p>	 <p>Crankshaft remover 09920-13120</p>	 <p>Clutch holder 09920-30220</p>

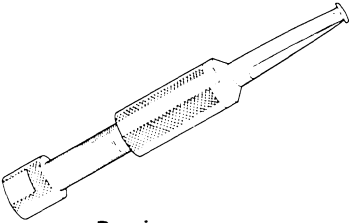
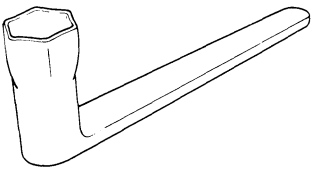
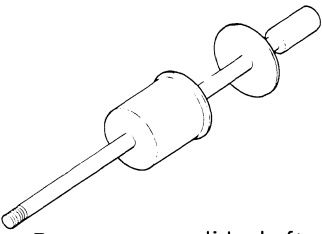
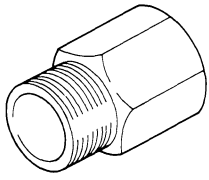
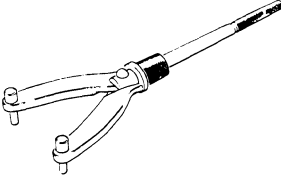
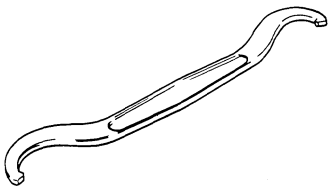
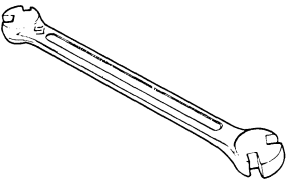
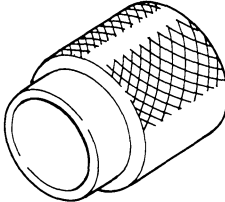
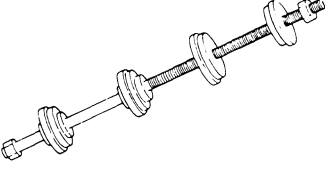
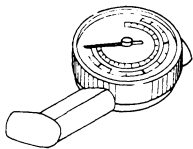
 <p>Bearing remover 09921-20210</p>	 <p>Spark plug wrench 09930-10111</p>	 <p>Rotor remover slide shaft 09930-30102</p>
 <p>Attachment C (27 mm screw) 09930-30161</p>	 <p>Rotor holder 09930-40113</p>	 <p>Steering stem nut wrench 09940-10122</p>
 <p>Spoke nipple wrench 09940-60113</p>	 <p>Steering race installer 09940-53111</p>	 <p>Steering race and swing arm bearing installer 09941-34513</p>
 <p>Tire pressure gauge 96200-41330</p>		

WIRE AND CABLE ROUTING

WIRE ROUTING

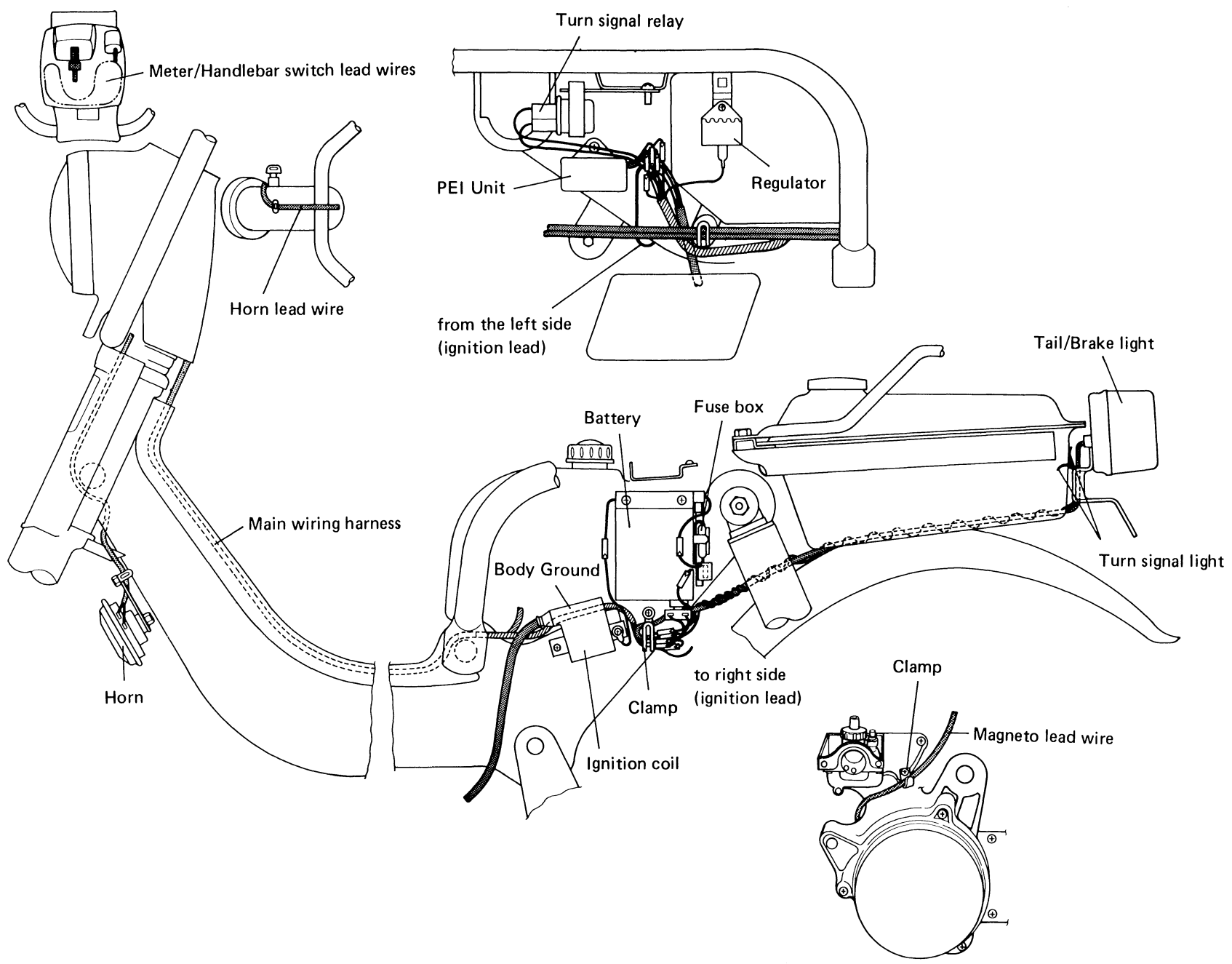

CABLE ROUTING

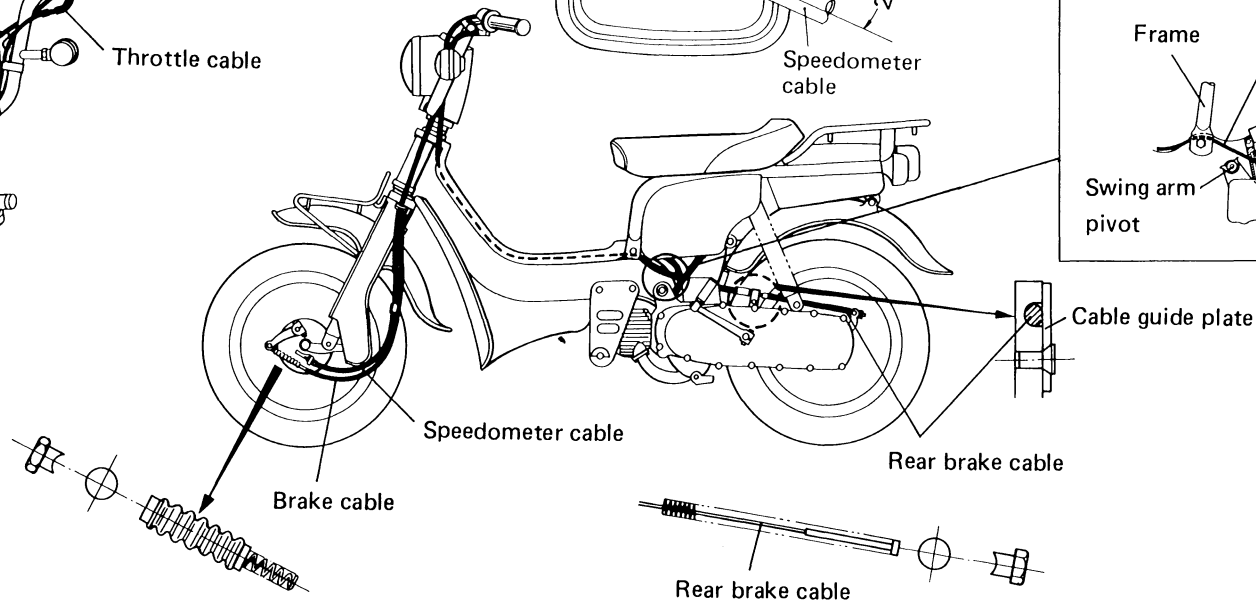
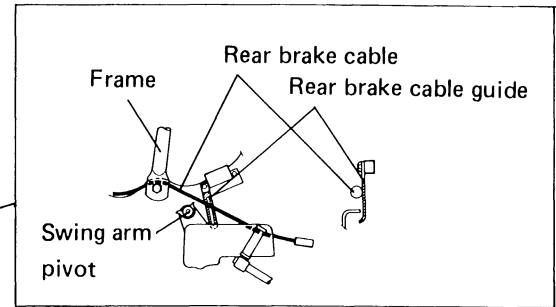
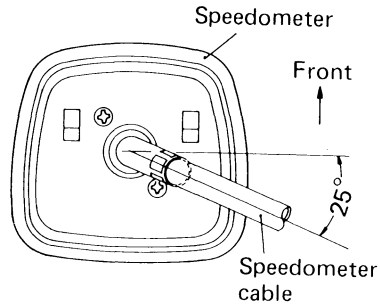
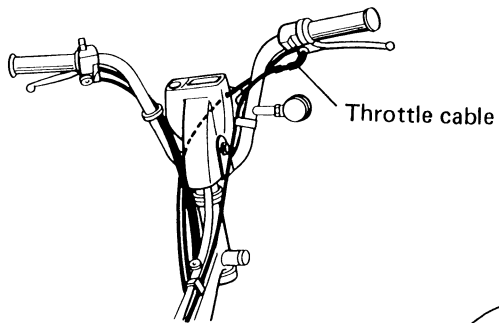
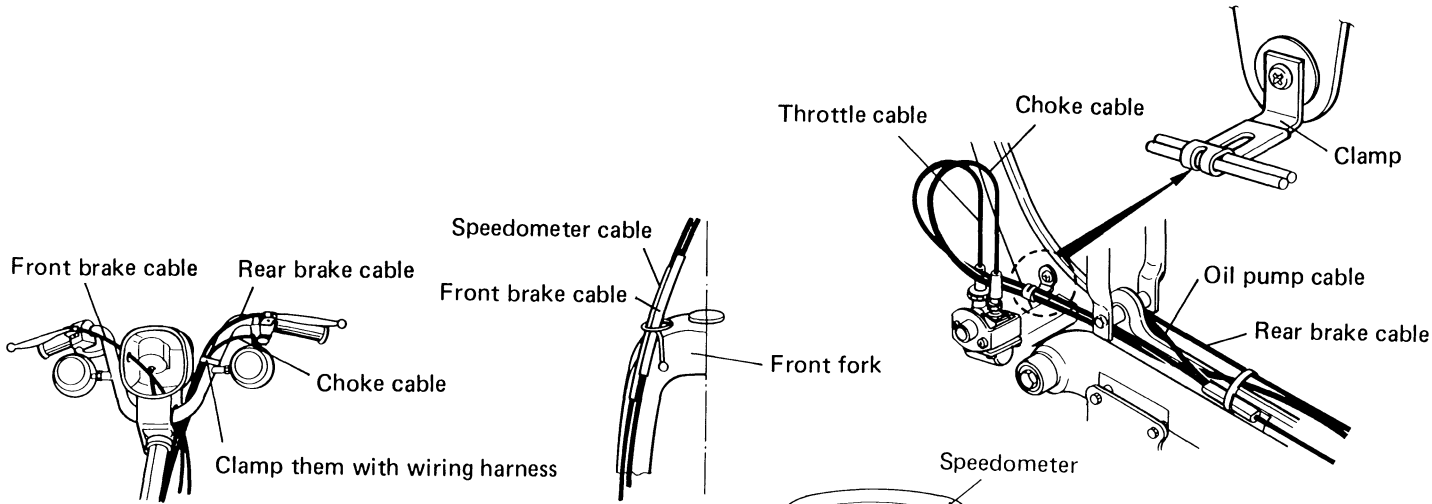

WIRING DIAGRAM

WIRE COLOR

- GGreen
- GrGray
- OOrange
- RRed
- WWhite
- YYellow
- B/RBlack with Red tracer
- B/WBlack with White tracer
- B/YBlack with Yellow tracer
- R/BRed with Black tracer
- W/RWhite with Red tracer
- Y/RYellow with Red tracer

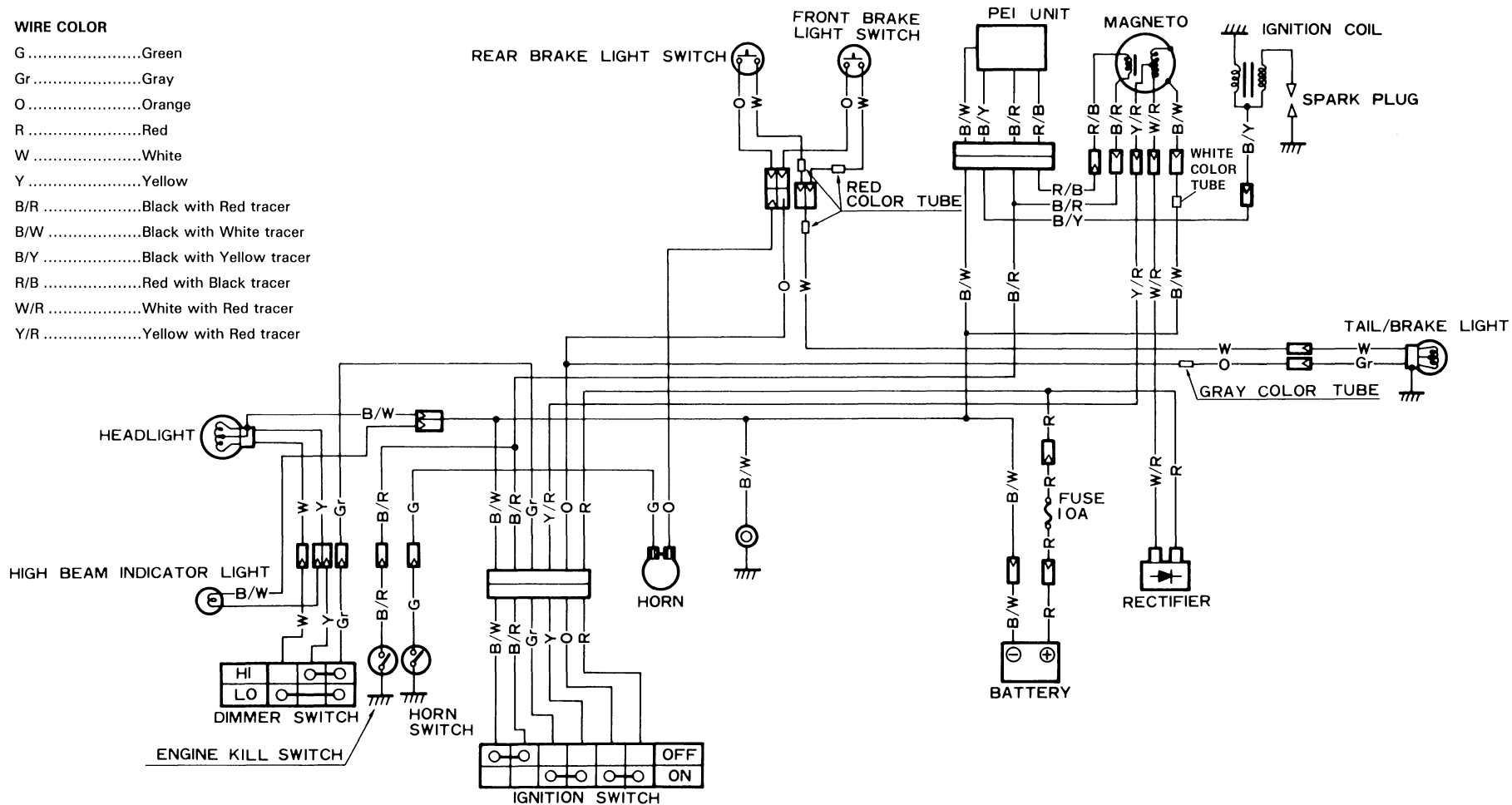

SERVICE DATA

CYLINDER + PISTON + PISTON RING

Unit: mm (in)

ITEM	STANDARD			LIMIT
Piston to cylinder clearance	0.070 – 0.080 (0.0028 – 0.0031)			0.120 (0.0047)
Cylinder bore	41.000 – 41.015 (1.6142 – 1.6148) Measure at the 15 (0.6) from top surface.			41.060 (1.6165)
Piston diam.	40.925 – 40.940 (1.6112 – 1.6118) Measure at the 23 (0.9) from skirt end.			40.880 (1.6094)
Cylinder distortion	—————			0.05 (0.002)
Cylinder head distortion	—————			0.05 (0.002)
Piston ring free end gap	1st	R	Approx. 4.5 (0.18)	3.6 (0.14)
		T	Approx. 5.0 (0.20)	4.0 (0.16)
	2nd	R	Approx. 4.5 (0.18)	3.6 (0.14)
		T	Approx. 5.0 (0.20)	4.0 (0.16)
Piston ring end gap	0.10 – 0.25 (0.004 – 0.010)			0.75 (0.030)
Piston ring to groove clearance	1st	0.020 – 0.060 (0.0008 – 0.0024)		—————
	2nd	0.020 – 0.060 (0.0008 – 0.0024)		—————
Piston pin bore	11.998 – 12.006 (0.4724 – 0.4727)			12.030 (0.4736)
Piston pin O.D.	11.996 – 12.000 (0.4723 – 0.4724)			11.980 (0.4717)

CONROD + CRANKSHAFT

Unit: mm (in)

ITEM	STANDARD	LIMIT
Conrod small end I.D.	16.003 – 16.011 (0.6300 – 0.6304)	16.040 (0.6315)
Conrod deflection	————	3.0 (0.12)
Crank web to web width	40.0 ± 0.1 (1.57 ± 0.004)	————
Crankshaft runout	————	0.05 (0.002)

OIL PUMP

ITEM	SPECIFICATION
Oil pump reduction ratio	7.000 (14 / 2)
CCI pump discharge rate (Full open)	1.02 – 1.26 ml (0.034 / 0.036 – 0.043 / 0.044 US/Imp oz) for 6 minutes at 2000 r/min.

CLUTCH

Unit: mm (in)

ITEM	STANDARD		LIMIT
Clutch wheel I.D.	Low	87.00 – 87.15 (3.425 – 3.431)	87.40 (3.441)
	High	105.00 – 105.15 (4.134 – 4.140)	105.50 (4.154)
Clutch shoe O.D.	Low	86.9 – 87.0 (3.42 – 3.43)	No groove at any part
	High	104.7 – 104.8 (4.12 – 4.13)	No groove at any part
Clutch engagement	2500 ± 200 r/min.		————
Clutch lock-up	3700 ± 300 r/min.		————
Clutch spring free length	Low	————	28 (1.10)
	High	————	33 (1.30)

TRANSMISSION

Unit: mm (in)

ITEM	STANDARD		LIMIT
Primary reduction ratio	1.000		———
Final reduction ratio	8.696 (31 / 13 X 62 / 17)		———
Gear ratios	Low	2.137 (62 / 29)	———
	2nd	1.421 (54 / 38)	———
Shift fork thickness	0.05 – 0.10 (0.002 – 0.004)		0.15 (0.006)

DRIVE CHAIN

Unit: mm (in)

ITEM	STANDARD		LIMIT
Drive chain	Type	D.I.D.: 270 H	———
	Links	64	———
	20 pitch length	170.0 (6.69)	173.0 (6.83)

CARBURETOR

Unit: mm (in)

ITEM	SPECIFICATION	
Carburetor type	MIKUNI VM 14 SH	
Bore size	14 (0.6)	
I.D. No.	02420	
Idle r/min.	1500 ± 150 r/min.	
Float height	22.4 ± 1.0 (0.88 ± 0.04)	
Main jet (M. J.)	# 57.5	
Air jet (A. J.)	2.5	
Jet needle (J. N.)	3D13–3	
Needle jet (N. J.)	E–2	
Cut-away (C. A.)	2.0	
Pilot jet (P. J.)	# 15	
Pilot outlet (P. O.)	0.9	
Air screw (A. S.)	1¼	
Valve seat (V. S.)	1.2	
Starter jet (G. S.)	35	
Throttle cable play	0.5 – 1.0 (0.02 – 0.04)	

ELECTRICAL

Unit: mm (in)

ITEM	SPECIFICATION		NOTE
Ignition timing	25° ± 2° B.T.D.C. at 4000 r/min.		
Spark plug	Type	NGK BP4HA or NIPPON DENSO W14FP-UL	
	Gap	0.6 – 0.8 (0.024 – 0.031)	
Ignition coil resistance	Primary	B/Y – Ground Approx. 0 – 1 Ω	
	Secondary	Plug cap – Ground Approx. 15 – 17 kΩ	
Magneto coil resistance	Lighting	Y/R – Ground Approx. 0 – 1 Ω	
	Charge	W/R – Ground Approx. 0 – 1 Ω	
	Primary	B/R – R/B Approx. 180 – 220 Ω	
Charging rate	Night	Above 0.7 A at 4000 r/min. Below 3.0 A at 8000 r/min.	
Lighting coil output	Above 5.5 V at 2500 r/min. Below 8.5 V at 8000 r/min.		
Battery	Type designation	6N4-2A	
	Capacity	6V14.4kC(4Ah)/10HR	
	Standard electrolyte S. G.	1.26 at 20°C (68°F)	
Fuse size	10 A		

BRAKE + WHEEL

Unit: mm (in)

ITEM	STANDARD		LIMIT
Front brake lever distance	20 – 30 (0.8 – 1.2)		_____
Rear brake lever distance	20 – 30 (0.8 – 1.2)		_____
Brake drum I.D.	Front	_____	100.7 (3.96)
	Rear	_____	100.7 (3.96)
Brake lining thickness	_____		1.5 (0.06)
Wheel rim runout	Axial	_____	2.0 (0.08)
	Radial	_____	2.0 (0.08)
Wheel axle runout	Front	_____	0.25 (0.010)
Tire size	Front	3.00 – 12 4PR	_____
	Rear	3.00 – 12 4PR	_____
Tire tread depth	Front	_____	1.6 (0.06)
	Rear	_____	1.6 (0.06)

SUSPENSION

Unit: mm (in)

ITEM	STANDARD	LIMIT	NOTE
Engine mounting pivot shaft runout	82 (3.1)	_____	
Swing arm pivot shaft runout	_____	0.6 (0.02)	

FUEL + OIL

ITEM	SPECIFICATION	NOTE
Fuel type	Use only unleaded or low-lead type gasoline of at least 83 – 95 pump octane ($\frac{R+M}{2}$ method) or 89 octane or higher rated by the Research method.	
Fuel tank including reserve	4.5 L (1.2 / 1.0 US/Imp gal)	
reserve	0.2 L (0.21 / 0.18 US/Imp qt)	
Engine oil type	Use SUZUKI CCI SUPER 2-CYCLE MOTOR LUBRICANT or an equivalent good quality synthetic based 2-cycle oil.	
Engine oil tank capacity	1.2 L (1.3 / 1.1 US/Imp qt)	
Transmission oil type	SAE 20W/40	
Transmission oil capacity	Change 800 ml (0.85 / 0.70 US/Imp qt)	
	Overhaul 850 ml (0.90 / 0.75 US/Imp qt)	

TIRE PRESSURE

COLD INFLATION TIRE PRESSURE	NORMAL RIDING		
	SOLO RIDING		
	kPa	kg/cm ²	psi
FRONT	125	1.25	18
REAR	150	1.50	21

WATTAGE

W (CP)

ITEM	SPECIFICATION
Headlight	HI 20
	LO 20
Tail/Brake light	5.3 / 17 (3 / 21)
High beam indicator light	1.7

VIEW OF SUZUKI FZ50“X”

RIGHT SIDE VIEW

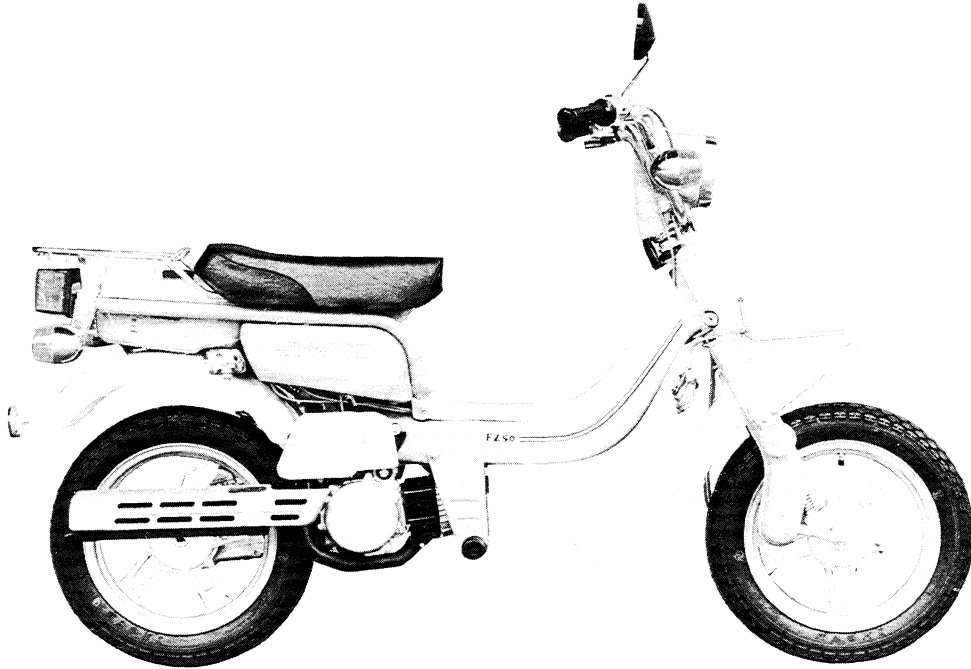

LEFT SIDE VIEW

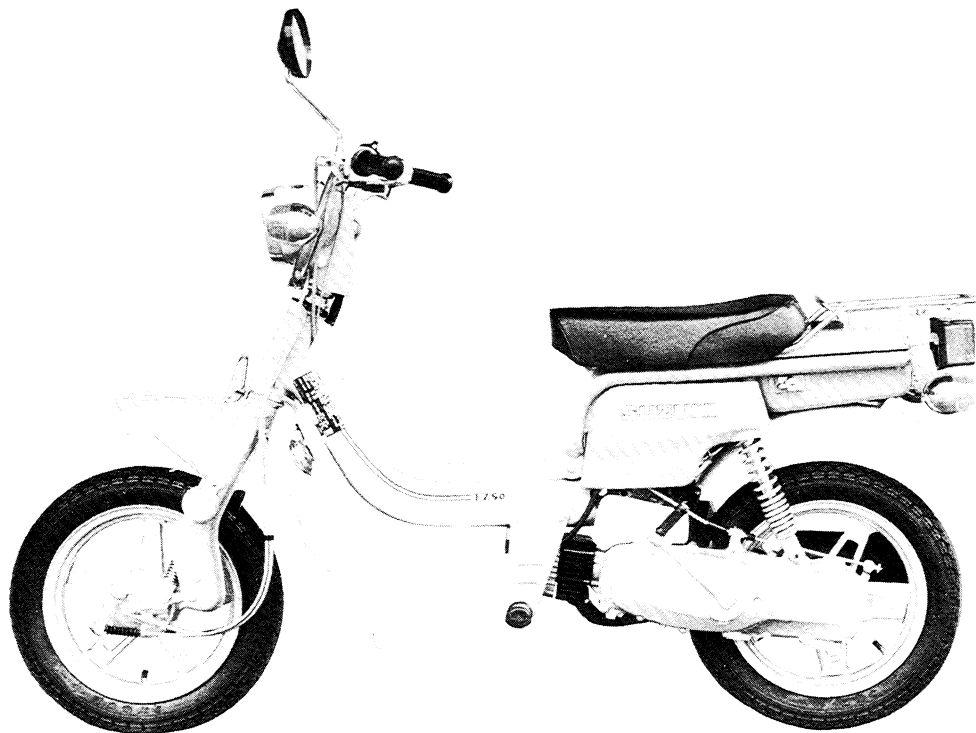

IGNITION COIL

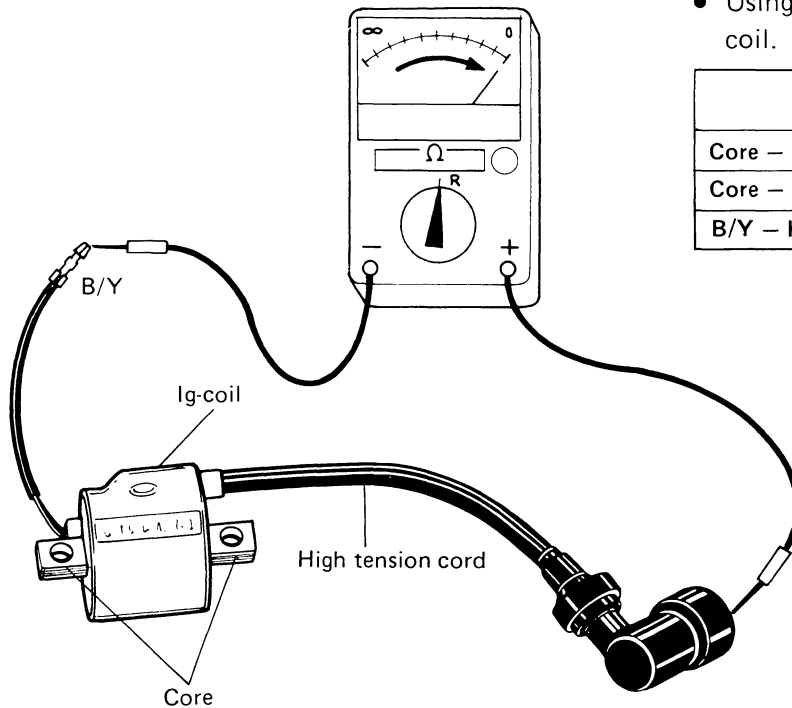

- Using the pocket tester check the ignition coil.

	Resistance	Knob position
Core – B/Y	0 – 1Ω	x 1Ω
Core – High tension	Approx. 4-6kΩ	x kΩ
B/Y – High tension	Approx. 4-6kΩ	x kΩ

TURN SIGNAL LIGHT SWITCH

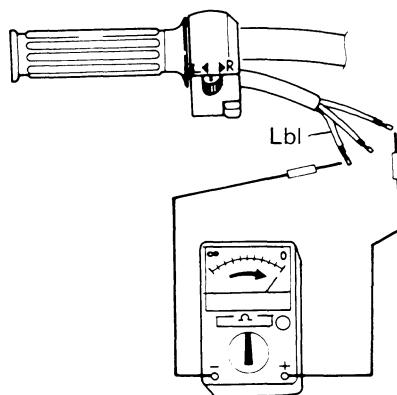

Check the conductivity between the lead terminals on the left handle switch box when the turn signal indicator knob is operated.

If there is conductivity where no connection is shown in the table or no conductivity where a connection is indicated, replace the switch.

	B	Lbl	Lg
Left	○ — ○		
Right		○ — ○	

WIRING DIAGRAM

WIRE COLOR

B	Black	B/R	Black with Red tracer
G	Green	B/W	Black with White tracer
Gr	Gray	B/Y	Black with Yellow tracer
Lbl	Light blue	R/B	Red with Black tracer
Lg	Light green	W/B	White with Black tracer
O	Orange	W/R	White with Red tracer
R	Red	Y/R	Yellow with Red tracer
W	White		
Y	Yellow		

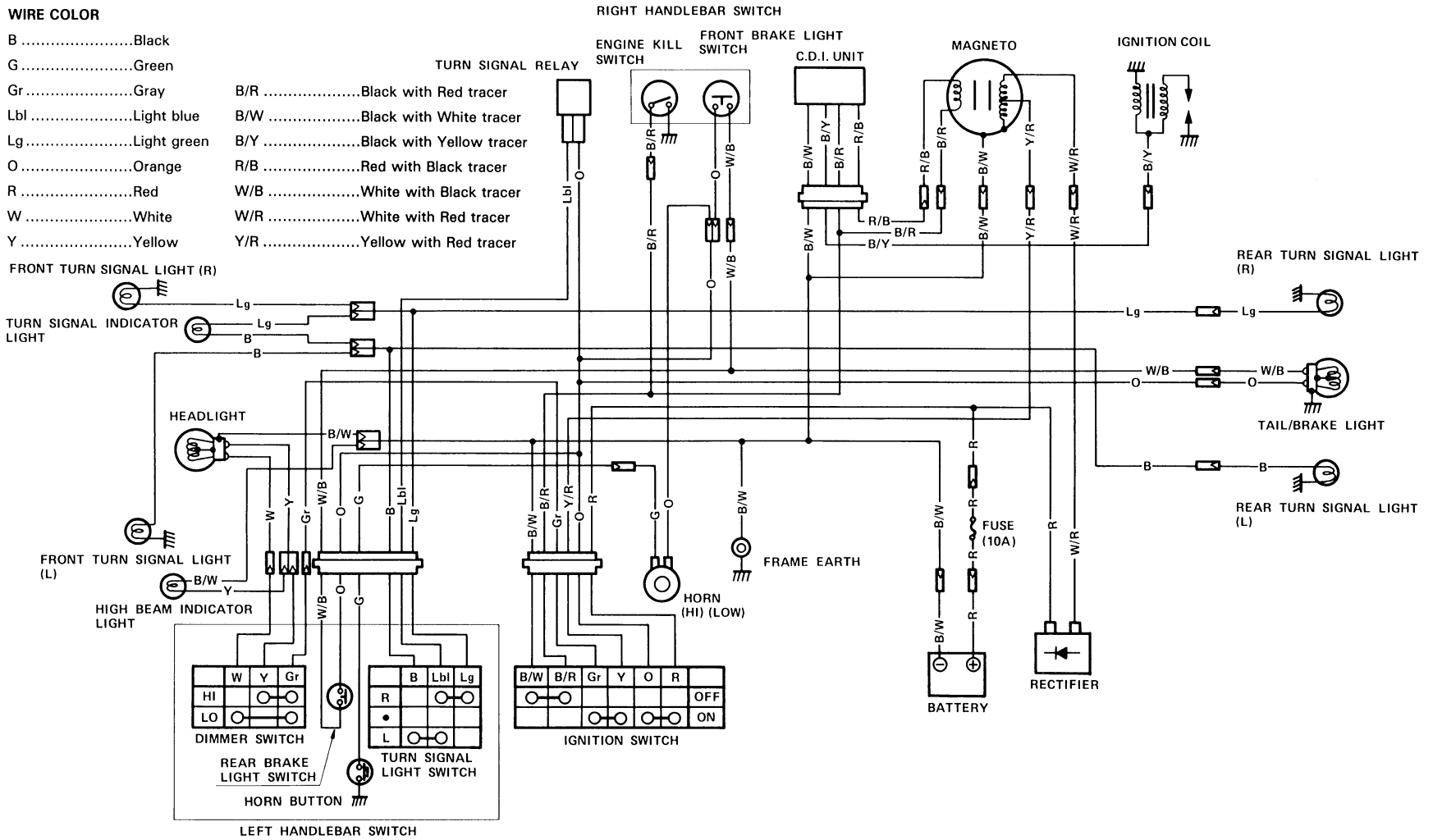

SERVICE DATA

CYLINDER + PISTON + PISTON RING

Unit: mm (in)

ITEM	STANDARD		LIMIT
Piston to cylinder clearance	0.070 – 0.080 (0.0028 – 0.0031)		0.120 (0.0047)
Cylinder bore	41.000 – 41.015 (1.6142 – 1.6148) Measure at the 15 (0.6) from top surface.		41.060 (1.6165)
Piston diam.	40.925 – 40.940 (1.6112 – 1.6118) Measure at the 23 (0.9) from skirt end.		40.880 (1.6094)
Cylinder distortion	—————		0.05 (0.002)
Cylinder head distortion	—————		0.05 (0.002)
Piston ring free end gap	1st	R Approx. 4.5 (0.18)	3.6 (0.14)
		T Approx. 5.0 (0.20)	4.0 (0.16)
	2nd	R Approx. 4.5 (0.18)	3.6 (0.14)
		T Approx. 5.0 (0.20)	4.0 (0.16)
Piston ring end gap	0.10 – 0.25 (0.004 – 0.010)		0.75 (0.030)
Piston ring to groove clearance	1st	0.020 – 0.060 (0.0008 – 0.0024)	—————
	2nd	0.020 – 0.060 (0.0008 – 0.0024)	—————
Piston pin bore	11.998 – 12.006 (0.4724 – 0.4727)		12.030 (0.4736)
Piston pin O.D.	11.996 – 12.000 (0.4723 – 0.4724)		11.980 (0.4717)

CONROD + CRANKSHAFT

Unit: mm (in)

ITEM	STANDARD	LIMIT
Conrod small end I.D.	16.003 – 16.011 (0.6300 – 0.6304)	16.040 (0.6315)
Conrod deflection	—————	3.0 (0.12)
Crank web to web width	40.0 ± 0.1 (1.57 ± 0.004)	—————
Crankshaft runout	—————	0.05 (0.002)

OIL PUMP

ITEM	SPECIFICATION
Oil pump reduction ratio	7.000 (14 / 2)
CCI pump discharge rate (Full open)	1.02 – 1.26 ml (0.034 / 0.036 – 0.043 / 0.044 US / Imp oz) for 6 minutes at 2000 r/min.

CLUTCH

Unit: mm (in)

ITEM	STANDARD		LIMIT
Clutch wheel I.D.	Low	87.00 – 87.15 (3.425 – 3.431)	87.40 (3.441)
	High	105.00 – 105.15 (4.134 – 4.140)	105.50 (4.154)
Clutch shoe O.D.	Low	86.9 – 87.0 (3.42 – 3.43)	No groove at any part
	High	104.7 – 104.8 (4.12 – 4.13)	No groove at any part
Clutch engagement	2500 ± 200 r/min.		————
Clutch lock-up	3700 ± 300 r/min.		————
Clutch spring free length	Low	————	28 (1.10)
	High	————	33 (1.30)

TRANSMISSION

Unit: mm (in)

ITEM	STANDARD		LIMIT
Primary reduction ratio	1.000		————
Final reduction ratio	8.696 (31 / 13 X 62 / 17)		————
Gear ratios	Low	2.137 (62 / 29)	————
	2nd	1.421 (54 / 38)	————
Shift fork thickness	0.05 – 0.10 (0.002 – 0.004)		0.15 (0.006)

DRIVE CHAIN

Unit: mm (in)

ITEM	STANDARD		LIMIT
Drive chain	Type	D.I.D.: 270 H	————
	Links	64	————
	20 pitch length	170.0 (6.69)	173.0 (6.83)

CARBURETOR

Unit: mm (in)

ITEM	SPECIFICATION
Carburetor type	MIKUNI VM 14 SH
Bore size	14 (0.6)
I.D. No.	02421
Idle r/min.	1500 ± 150 r/min.
Float height	22.4 ± 1.0 (0.88 ± 0.04)
Main jet (M. J.)	# 57.5
Air jet (A. J.)	2.5
Jet needle (J. N.)	3D13-3
Needle jet (N. J.)	E-2
Cut-away (C. A.)	2.0
Pilot jet (P. J.)	# 15
Pilot outlet (P. O.)	0.9
Air screw (A. S.)	1¾
Valve seat (V. S.)	1.5
Starter jet (G. S.)	35
Throttle cable play	0.5 – 1.0 (0.02 – 0.04)

ELECTRICAL

Unit: mm (in)

ITEM	SPECIFICATION		NOTE
Ignition timing	25° ± 2° B.T.D.C. at 4000 r/min.		
Spark plug	Type	NGK BP4HA or NIPPON DENSO W14FP-UL	
	Gap	0.6 – 0.8 (0.024 – 0.031)	
Ignition coil resistance	Primary	B/Y – Ground Approx. 0 – 1 Ω	
	Secondary	Plug cap – Ground Approx. 4 – 6 kΩ	
Magneto coil resistance	Lighting	B/W – Y Approx. 0.4 Ω	
	Charge	B/W – W/R Approx. 0.75 Ω	
	Primary	B/R – R/B Approx. 230 Ω	
Charging rate	Night	Above 0.7 A at 4000 r/min. Below 3.0 A at 8000 r/min.	
Lighting coil output	Above 5.5 V at 2500 r/min. Below 8.5 V at 8000 r/min.		
Battery	Type designation	6N4-2A	
	Capacity	6V14.4kC(4Ah)/10HR	
	Standard electrolyte S. G.	1.26 at 20°C (68°F)	
Fuse size	10 A		

BRAKE + WHEEL

Unit: mm (in)

ITEM	STANDARD		LIMIT
Front brake lever distance	20 – 30 (0.8 – 1.2)		_____
Rear brake lever distance	20 – 30 (0.8 – 1.2)		_____
Brake drum I.D.	Front	_____	100.7 (3.96)
	Rear	_____	100.7 (3.96)
Brake lining thickness	_____		1.5 (0.06)
Wheel rim runout	Axial	_____	2.0 (0.08)
	Radial	_____	2.0 (0.08)
Wheel axle runout	Front	_____	0.25 (0.010)
Tire size	Front	3.00 – 12 4PR	_____
	Rear	3.00 – 12 4PR	_____
Tire tread depth	Front	_____	1.6 (0.06)
	Rear	_____	1.6 (0.06)

SUSPENSION

Unit: mm (in)

ITEM	STANDARD	LIMIT	NOTE
Engine mounting pivot shaft runout	82 (3.1)	_____	
Swing arm pivot shaft runout	_____	0.6 (0.02)	

FUEL + OIL

ITEM	SPECIFICATION	NOTE
Fuel type	Use only unleaded or low-lead type gasoline of at least 83 – 95 pump octane ($\frac{R+M}{2}$ method) or 89 octane or higher rated by the Research method.	
Fuel tank including reserve	4.5 L (1.2 / 1.0 US/Imp gal)	
reserve	0.2 L (0.21 / 0.18 US/Imp qt)	
Engine oil type	Use SUZUKI CCI SUPER 2-CYCLE MOTOR LUBRICANT or an equivalent good quality synthetic based 2-cycle oil.	
Engine oil tank capacity	1.2 L (1.3 / 1.1 US/Imp qt)	
Transmission oil type	SAE 20W/40	
Transmission oil capacity	Change 800 ml (0.85 / 0.70 US/Imp qt)	
	Overhaul 850 ml (0.90 / 0.75 US/Imp qt)	

TIRE PRESSURE

COLD INFLATION TIRE PRESSURE	NORMAL RIDING		
	SOLO RIDING		
	kPa	kg/cm ²	psi
FRONT	125	1.25	18
REAR	150	1.50	21

WATTAGE

W (CP)

ITEM	SPECIFICATION
Headlight	HI 20
	LO 20
Tail/Brake light	5.3 / 17 (3 / 21)
Turn signal light	17
Turn signal indicator light	3
High beam indicator light	1.7

FZ50“Z”

CONTENTS

SERVICE DATA	6- 1
--------------------	------

SERVICE DATA

CYLINDER + PISTON + PISTON RING

Unit: mm

ITEM	STANDARD		LIMIT	
Piston to cylinder clearance	0.065—0.075		0.120	
Cylinder bore	41.000—41.015 Measure at the 15 from top surface		41.060	
Piston diam.	40.930—40.945 Measure at the 23 from skirt end		40.880	
Cylinder distortion	—		0.05	
Cylinder head distortion	—		0.05	
Piston ring free end gap	1st	R	Approx. 4.5	3.6
		T	Approx. 5.0	4.0
	2nd	R	Approx. 4.5	3.6
		T	Approx. 5.0	4.0
Piston ring end gap	0.10—0.25		0.75	
Piston ring to groove clearance	1st	0.020—0.060	—	
	2nd	0.020—0.060	—	
Piston pin bore	11.998—12.006		12.030	
Piston pin O.D.	11.995—12.000		11.980	

CONROD + CRANKSHAFT

Unit: mm

ITEM	STANDARD	LIMIT
Conrod small end I.D.	16.003—16.011	16.040
Conrod deflection	—	3.0
Crank web to web width	40.0 ± 0.1	—
Crankshaft runout	—	0.05

OIL PUMP

ITEM	SPECIFICATION
Oil pump reduction ratio	7.000 (14/2)
CCI pump discharge rate (Full open)	1.02—1.26 ml for 6 minutes at 2 000 r/min.

CLUTCH

Unit: mm

ITEM	STANDARD		LIMIT
Clutch wheel I.D.	Low	87.00–87.15	87.40
	High	105.00–105.15	105.50
Clutch shoe O.D.	Low	86.9–87.0	No groove at any part
	High	104.7–104.8	No groove at any part
Clutch engagement	2 500 ± 200 r/min.		—
Clutch lock-up	3 700 ± 300 r/min.		—
Clutch spring free length	—		28
	—		33

TRANSMISSION

Unit: mm

ITEM	STANDARD		LIMIT
Primary reduction ratio	1.000		—
Final reduction ratio	8.696 (31/13 x 62/17)		—
Gear ratios	Low	2.137 (62/29)	—
	2nd	1.421 (54/38)	—

DRIVE CHAIN

Unit: mm

ITEM	STANDARD		LIMIT
Drive chain	Type	D.I.D.: 270H	—
	Links	64	—
	20 pitch length	170.0	173.0

CARBURETOR

Unit: mm

ITEM		SPECIFICATION
Carburetor type		MIKUNI VM14SH
Bore size		14
I.D. No.		02421
Idle r/min.		1 500 ± 150 r/min.
Float height		22.4 ± 1.0
Main jet	(M.J.)	57.5
Air jet	(A.J.)	2.5
Jet needle	(J.N.)	3D13-3rd
Needle jet	(N.J.)	E-2
Cut-away	(C.A.)	2.0
Pilot jet	(P.J.)	#15
Pilot outlet	(P.O.)	0.9
Air screw	(A.S.)	1 3/4 turn out
Valve seat	(V.S.)	1.5
Starter jet	(G.S.)	#35
Throttle cable play		0.5—1.0

ELECTRICAL

Unit: mm

ITEM	SPECIFICATION		NOTE
Ignition timing	25° ± 2° B.T.D.C. at 4 000 r/min.		
Spark plug	Type	NGK BP4HA or NIPPON DENSO W14EP-UL	
	Gap	0.6—0.8	
Ignition coil resistance	Primary	B/Y—Ground Approx. 2—4 Ω	
	Secondary	Plug cap—Ground Approx. 5—7 kΩ	
Magneto coil resistance	Lighting	B/W—Y/W Approx. 0.24 Ω	
	Charge	B/W—W/R Approx. 0.32 Ω	
	Primary	B/R—R/B Approx. 205 Ω	
Charging rate	Night	Above 0.8A at 4 000 r/min. Below 2.5 A at 8 000 r/min.	
Lighting coil output	Above 6.2 V at 2 500 r/min. Below 9.4 V at 8 000 r/min.		
Battery	Type designation	6N4-2A	
	Capacity	6V14.4kC(4Ah)/10HR	
	Standard electrolyte S.G.	1.26 at 20°C (68°F)	
Fuse size	Main	10 A	

WATTAGE

(W)

ITEM		SPECIFICATION
Headlight	HI	20
	LO	20
Tail/Brake light		5.3/17
Turn signal light		17
Turn signal indicator light		3
High beam indicator light		1.7

BRAKE + WHEEL

Unit: mm

ITEM	STANDARD		LIMIT
Front brake lever distance	20—30		——
Rear brake pedal free travel	20—30		——
Brake drum I.D.	Front	——	100.7
	Rear	——	100.7
Brake lining thickness	——		1.5
Wheel rim runout	Axial	——	2.0
	Radial	——	2.0
Wheel axle runout	Front	——	0.25
Tire size	Front	3.00-12 4PR	——
	Rear	3.00-12 4PR	——
Tire tread depth	Front	——	1.6
	Rear	——	1.6

SUSPENSION

Unit: mm

ITEM	STANDARD	LIMIT	NOTE
Pivot shaft runout	——	0.6	

TIRE PRESSURE

COLD INFLATION TIRE PRESSURE	kPa	kg/cm ²	psi
FRONT	125	1.25	18
REAR	150	1.50	22

FUEL + OIL

ITEM	SPECIFICATION	NOTE
Fuel type	Use only unleaded or low-lead type gasoline of at least 85-95 pump octane ($\frac{R+M}{2}$ method) or 89 octane or higher rated by the Research method.	
Fuel tank including reserve	4.5 L	
reserve	0.2 L	
Engine oil type	Use SUZUKI CCI SUPER 2-CYCLE MOTOR LUBRICANT or an equivalent good quality synthetic based 2-cycle oil.	
Engine oil tank capacity	1.2 L	
Transmission oil type	SAE 20W/40	
Transmission oil capacity	Change 800 ml	
	Overhaul 850 ml	

FZ50“D”

CONTENTS

SERVICE DATA	7- 1
--------------------	------

SERVICE DATA

CYLINDER + PISTON + PISTON RING

Unit: mm (in)

ITEM	STANDARD		LIMIT	
Piston to cylinder clearance	0.065 – 0.075 (0.0026 – 0.0030)		0.120 (0.0047)	
Cylinder bore	41.000 – 41.015 (1.6142 – 1.6148) Measure at 15 (0.6) from the top surface.		41.065 (1.6167)	
Piston diam.	40.930 – 40.945 (1.6114 – 1.6120) Measure at 23 (0.9) from the skirt end.		40.880 (1.6094)	
Cylinder distortion	—————		0.05 (0.002)	
Cylinder head distortion	—————		0.05 (0.002)	
Piston ring free end gap	1st	R	Approx. 4.5 (0.18)	3.6 (0.14)
		T	Approx. 5.0 (0.20)	4.0 (0.16)
	2nd	R	Approx. 4.5 (0.18)	3.6 (0.14)
		T	Approx. 5.0 (0.20)	4.0 (0.16)
Piston ring end gap	0.10 – 0.25 (0.004 – 0.010)		0.75 (0.030)	
Piston ring to groove clearance	1st	0.020 – 0.060 (0.0080 – 0.0024)	—————	
	2nd	0.020 – 0.060 (0.0080 – 0.0024)	—————	
Piston pin bore	11.998 – 12.006 (0.4724 – 0.4727)		12.030 (0.4736)	
Piston pin O.D.	11.996 – 12.000 (0.4723 – 0.4724)		11.980 (0.4717)	

CONROD + CRANKSHAFT

Unit: mm (in)

ITEM	STANDARD	LIMIT
Conrod small end I.D.	16.003 – 16.011 (0.6300 – 0.6304)	16.040 (0.6315)
Conrod deflection	—————	3.0 (0.12)
Crank web to web width	40.0 ± 0.1 (1.57 ± 0.004)	—————
Crankshaft runout	—————	0.05 (0.02)

OIL PUMP

ITEM	SPECIFICATION
Oil pump reduction ratio	7.000 (14/2)
CCI pump discharge rate (Full open)	1.01 – 1.24 ml (0.037/0.036 – 0.042/0.044 US/Imp oz) for 5 minutes at 2000 r/min.

CLUTCH

Unit: mm (in)

ITEM	STANDARD		LIMIT
Clutch wheel I.D.	No 1	87.00 – 87.15 (3.425 – 3.431)	87.40 (3.441)
	No 2	105.00 – 105.15 (4.134 – 4.140)	105.40 (4.154)
Clutch shoe O.D.	No 1	86.90 – 87.00 (3.421 – 3.425)	No groove at any part
	No 2	104.70 – 104.80 (4.122 – 4.126)	No groove at any part
Clutch engagement	Low	2600 ± 200 r/min.	————
Clutch lock-up	Low	3650 ± 250 r/min.	————
Gear shifting point	Low to top	18 – 22 km/h	————
Clutch spring free length	No 1	————	35.7 (1.41)
	No 2	————	40.4 (1.59)

TRANSMISSION

Unit: mm (in) Except ratio

ITEM	STANDARD		LIMIT
Final reduction ratio	3.647 (62/17)		————
Gear ratios	Low	18.593 (62/29 × 31/13 × 62/17)	————
	Top	12.358 (54/38 × 31/13 × 62/17)	————

DRIVE CHAIN

Unit: mm (in)

ITEM	STANDARD		LIMIT
Drive chain	Type	D.I.D.: 270H	————
	Links	64	————
	20 pitch length	————	173.4 (6.83)

CARBURETOR

ITEM	SPECIFICATION
Carburetor type	MIKUNI VM 14 SH
Bore size	14
I.D. No.	02421
Idle r/min.	1500 ± 150 r/min.
Float height	22.4 ± 1.0 mm (0.88 ± 0.004 in)
Main jet (M. J.)	# 57.5
Air jet (A. J.)	2.5
Jet needle (J. N.)	3D 13 – 3rd
Needle jet (N. J.)	E – 2
Cut-away (C. A.)	2.0
Pilot jet (P. J.)	# 15
Pilot outlet (P. O.)	0.9 mm (0.04 in)
Air screw (A. S.)	1¾ turn out
Valve seat (V. S.)	1.5 mm (0.06 in)
Starter jet (G. S.)	# 35
Throttle cable play	0.5 – 1.0 mm (0.02 – 0.04 in)

ELECTRICAL

Unit: mm (in)

ITEM	SPECIFICATION		NOTE
Ignition timing	25° ± 2° B.T.D.C. at 4000 r/min.		
Spark plug	Type	N.G.K BP4HA N.D. W14FP-UL	
	Gap	0.6 – 0.8 (0.02 – 0.03)	
Spark performance	Over 8 (0.3) at 1 atm		
Magneto coil resistance	Primary	Approx. B/R – B/W 160 – 250 Ω	
	Lighting	Approx. Y/R – B/W 0 – 1 Ω	
	Charging	Approx. W/R – B/W 0 – 1 Ω	
Charging rate	Above	0.7 A at 4000 r/min.	
	Below	3 A at 8000 r/min	
Lighting coil output	Above	5.5 V at 2500 r/min.	
	Below	8.5 V at 8000 r/min.	
Battery	Type designation	6N4 – 2A	
	Capacity	6V14.4 kC(4Ah)/10HR	
	Standard electrolyte S. G.	1.26 at 20°C (68°F)	
Fuse size	Main	10 A	

BRAKE + WHEEL

Unit: mm (in)

ITEM	STANDARD		LIMIT
Front and rear brake lever distance	20 – 30 (0.8 – 1.2)		_____
Brake drum I.D.	Front	_____	100.7 (3.96)
	Rear	_____	100.7 (3.96)
Brake lining thickness	_____		1.5 (0.06)
Wheel rim runout	Axial	_____	2.0 (0.08)
	Radial	_____	2.0 (0.08)
Wheel axle runout	Front	_____	0.25 (0.010)
	Rear	_____	0.25 (0.010)
Tire size	Front	3.00 – 12 4PR	_____
	Rear	3.00 – 12 4PR	_____
Tire tread depth	Front	_____	1.6 (0.06)
	Rear	_____	1.6 (0.06)

SUSPENSION

Unit: mm (in)

ITEM	STANDARD	LIMIT	NOTE
Rear wheel travel	82 (3.2)	_____	
Swing arm pivot shaft runout	_____	0.6 (0.024)	

FUEL + OIL

ITEM	SPECIFICATION	NOTE
Fuel type	Use only unleaded or low-lead type gasoline of at least 85 – 95 pump octane ($\frac{R+M}{2}$) Method or 89 octane or higher rated by the Research method.	
Fuel tank including reserve	4.5 L (1.2/1.0 US/Imp gal)	
reserve	0.2 L (1.2/0.18 US/Imp qt)	
Engine oil type	Use SUZUKI CCI SUPER 2-CYCLE MOTOR LUBRICANT or an equivalent good quality syntletic based 2-cycle oil.	
Engine oil tank capacity	1.2 L (1.27/1.06 US/Imp qt)	
Transmission oil type	SAE 20W/40	
Transmission oil capacity	Change 800 ml (0.85/0.70 US/Imp qt)	
	Overhaul 850 ml (0.90/0.75 US/Imp qt)	

TIRE PRESSURE

COLD INFLATION TIRE PRESSURE	NORMAL RIDING		
	SOLO RIDING		
	kPa	kg/cm ²	psi
FRONT	125	1.25	18
REAR	150	1.50	22

WATTAGE

Unit. W

ITEM		SPECIFICATION
Headlight	HI	20
	LO	20
Tail/Brake light		5.3/17 (3/21 CP)
Turn signal light		17 (21 CP)
Turn signal indicator light		3
High beam indicator light		1.7

FZ50“G”

CONTENTS

SERVICE DATA.....	8- 1
-------------------	------

SERVICE DATA

CYLINDER + PISTON + PISTON RING

Unit: mm (in)

ITEM	STANDARD		LIMIT	
Piston to cylinder clearance	0.065—0.075 (0.0026—0.0030)		0.120 (0.0047)	
Cylinder bore	41.000—41.015 (1.6142—1.6148) Measure at 15 (0.6) from the top surface		41.065 (1.6167)	
Piston diam.	40.930—40.945 (1.6114—1.6120) Measure at 23 (0.9) from the skirt end		40.880 (1.6094)	
Cylinder distortion	—		0.05 (0.002)	
Cylinder head distortion	—		0.05 (0.002)	
Piston ring free end gap	1st	R	Approx. 4.5 (0.18)	3.6 (0.14)
		T	Approx. 5.0 (0.20)	4.0 (0.16)
	2nd	R	Approx. 4.5 (0.18)	3.6 (0.14)
		T	Approx. 5.0 (0.20)	4.0 (0.16)
Piston ring end gap	0.10—0.25 (0.004—0.010)		0.75 (0.30)	
Piston ring to groove clearance	1st	0.020—0.060 (0.0008—0.0024)	—	
	2nd	0.020—0.060 (0.0008—0.0024)	—	
Piston pin bore	11.998—12.006 (0.4724—0.4727)		12.030 (0.4736)	
Piston pin O.D.	11.996—12.000 (0.4723—0.4724)		11.980 (0.4717)	

CONROD + CRANKSHAFT

Unit: mm (in)

ITEM	STANDARD	LIMIT
Conrod small end I.D.	16.003—16.011 (0.6300—0.6304)	16.040 (0.6315)
Conrod deflection	—	3.0 (0.12)
Crank web to web width	40.1 ± 0.1 (1.57 ± 0.004)	—
Crankshaft runout	—	0.05 (0.02)

OIL PUMP

ITEM	SPECIFICATION
Oil pump reduction ratio	7.000 (14/ 2)
CCI pump discharge rate (Full open)	1.01—1.24 ml for 5 minutes at 2 000 r/min.

CLUTCH

Unit: mm (in)

ITEM	STANDARD		LIMIT
Clutch wheel I.D.	No.1	87.00–87.15 (3.425–3.431)	87.40 (3.441)
	No.2	105.00–105.15 (4.134–4.140)	105.40 (4.154)
Clutch shoe O.D.	No.1	86.90–87.00 (3.421–3.425)	No groove at any part
	No.2	104.70–104.80 (4.122–4.126)	No groove at any part
Clutch engagement	Low	2 600 ± 200 r/min.	——
Clutch lock-up	Low	3 650 ± 250 r/min.	——
Gear shifting point	Low to top	18–22 km/h	——
Clutch spring free length	No.1	——	35.7 (1.41)
	No.2	——	40.4 (1.59)

TRANSMISSION

Unit: mm (in) Except ratio

ITEM	STANDARD		LIMIT
Final reduction ratio	3.647 (62/17)		——
Gear ratios	Low	18.593 (62/29 × 31/13 × 62/17)	——
	Top	12.358 (54/38 × 31/13 × 62/17)	——

DRIVE CHAIN

Unit: mm (in)

ITEM	STANDARD		LIMIT
Drive chain	Type	D.I.D.: 270H	——
	Links	64	——
	20-pitch length	——	173.4 (6.83)

CARBURETOR

ITEM	SPECIFICATION	
Carburetor type	MIKUNI VM14SH	
Bore size	14 mm (0.55 in)	
I.D. No.	02421	
Idle r/min.	1 500 ± 150 r/min.	
Float height	22.4 ± 1.0 mm (0.08 ± 0.04 in)	
Main jet (M.J.)	#57.5	
Air jet (A.J.)	2.5 mm (0.10 in)	
Jet needle (J.N.)	3D13-3rd	
Needle jet (N.J.)	E-2	
Cut-away (C.A.)	2.0	
Pilot jet (P.J.)	#15	
Pilot outlet (P.O.)	0.9 mm (0.04 in)	
Air screw (A.S.)	1 3/4 turn out	

ITEM	SPECIFICATION
Valve seat (V.S.)	1.5 mm (0.06 in)
Starter jet (G.S.)	#35
Throttle cable play	0.5–1.0 mm (0.02–0.04 in)

ELECTRICAL

Unit: mm (in)

ITEM	SPECIFICATION	NOTE
Ignition timing	25° ± 2° B.T.D.C. at 4 000 r/min.	
Spark plug	Type	NGK: BP4HA N.D.: W14FP-UL
	Gap	0.6–0.8 (0.02–0.03)
Spark performance	Over 8 (0.3) at 1 atm.	
Magneto coil resistance	Primary	B/R–B/W Approx. 160–250 Ω
	Lighting	Y/R–B/W Approx. 0–1 Ω
	Charging	W/R–B/W Approx. 0–1 Ω
Charging rate	Above 0.7 A at 4 000 r/min. Below 3 A at 8 000 r/min.	
Lighting coil output	Above 5.5 V at 2 500 r/min. Below 8.5 V at 8 000 r/min.	
Battery	Type designation	6N4-2A
	Capacity	6V 14.4kC (4Ah)/10 HR
	Standard electrolyte S.G.	1.26 at 20°C (68°F)
Fuse size	Main	10 A

WATTAGE

Unit: W

ITEM	SPECIFICATION	
Headlight	HI	20
	LO	20
Tail/Brake light	5.3/17	
Turn signal light	17	
Turn signal indicator light	3	
High beam indicator light	1.7	

BRAKE + WHEEL

Unit: mm (in)

ITEM	STANDARD	LIMIT
Front brake cable play	3–7 (0.12–0.28)	—
Rear brake pedal free travel	20–30 (0.8–1.2)	—
Brake drum I.D.	Front	100.7 (3.96)
	Rear	100.7 (3.96)

ITEM	STANDARD		LIMIT
Brake lining thickness	—		1.5 (0.06)
Wheel rim runout	Axial	—	2.0 (0.08)
	Radial	—	2.0 (0.08)
Wheel axle runout	Front	—	0.25 (0.010)
	Rear	—	0.25 (0.010)
Tire size	Front	3.00-12 4PR	—
	Rear	3.00-12 4PR	—
Tire tread depth	Front	—	1.6 (0.06)
	Rear	—	1.6 (0.06)

SUSPENSION

Unit: mm (in)

ITEM	STANDARD	LIMIT	NOTE
Rear wheel travel	82 (3.2)	—	
Swingarm pivot shaft runout	—	0.6 (0.024)	

TIRE PRESSURE

COLD INFLATION TIRE PRESSURE	NORMAL RIDING		
	SOLO RIDING		
	kPa	kg/cm ²	psi
FRONT	125	1.25	18
REAR	150	1.50	21

FUEL + OIL

ITEM	SPECIFICATION	NOTE
Fuel type	Use only unleaded or low-lead type gasoline of at least 85-95 pump octane ($\frac{R+M}{2}$ method) or 89 octane or higher rated by the Research Method.	
Fuel tank including reserve	4.5 L (1.2/1.0 US/Imp gal)	
reserve	0.2 L (1.2/0.18 US/Imp qt)	
Engine oil type	SUZUKI CCI or SUZUKI CCI SUPER	
Engine oil tank capacity	1.2 L (1.27/1.06 US/Imp qt)	
Transmission oil type	SAE 20W/40	
Transmission oil capacity	Change	800 ml (0.85/0.70 US/Imp qt)
	Overhaul	850 ml (0.90/0.75 US/Imp qt)

FZ50“H”

CONTENTS

SERVICE DATA.....	9- 1
--------------------------	-------------

SERVICE DATA

CYLINDER + PISTON + PISTON RING

Unit: mm (in)

ITEM	STANDARD		LIMIT	
Piston to cylinder clearance	0.065–0.075 (0.0026–0.0030)		0.120 (0.0047)	
Cylinder bore	41.000–41.015 (1.6142–1.6148) Measure at 15 (0.6) from the top surface		41.065 (1.6167)	
Piston diam.	40.930–40.945 (1.6114–1.6120) Measure at 23 (0.9) from the skirt end.		40.880 (1.6094)	
Cylinder distortion	—		0.05 (0.002)	
Cylinder head distortion	—		0.05 (0.002)	
Piston ring free end gap	1st	R	Approx. 4.5 (0.18)	3.6 (0.14)
		T	Approx. 5.0 (0.20)	4.0 (0.16)
	2nd	R	Approx. 4.5 (0.18)	3.6 (0.14)
		T	Approx. 5.0 (0.20)	4.0 (0.16)
Piston ring end gap	0.10–0.25 (0.004–0.010)		0.75 (0.30)	
Piston ring to groove clearance	1st	0.020–0.060 (0.0008–0.0024)	—	
	2nd	0.020–0.060 (0.0008–0.0024)	—	
Piston pin bore	11.998–12.006 (0.4724–0.4727)		12.030 (0.4736)	
Piston pin O.D.	11.996–12.000 (0.4723–0.4724)		11.980 (0.4717)	

CONROD + CRANKSHAFT

Unit: mm (in)

ITEM	STANDARD	LIMIT
Conrod small end I.D.	16.003–16.011 (0.6300–0.6304)	16.040 (0.6315)
Conrod deflection	—	3.0 (0.12)
Crank web to web width	40.0 ± 0.1 (1.57 ± 0.004)	—
Crankshaft runout	—	0.05 (0.02)

OIL PUMP

ITEM	SPECIFICATION
Oil pump reduction ratio	7.000 (14/2)
CCI pump discharge rate (Full open)	1.01–1.24 ml for 5 minutes at 2 000 r/min.

CLUTCH

Unit: mm (in)

ITEM	STANDARD		LIMIT
Clutch wheel I.D.	No.1	87.00–87.15 (3.425–3.431)	87.40 (3.441)
	No.2	105.00–105.15 (4.134–4.140)	105.40 (4.154)
Clutch shoe O.D.	No.1	86.90–87.00 (3.421–3.425)	No groove at any part
	No.2	104.70–104.80 (4.122–4.126)	No groove at any part
Clutch engagement	Low	2 600 ± 200 r/min.	—
Clutch lock-up	Low	3 650 ± 250 r/min.	—
Gear sifting point	Low to top	18–22 km/h	—
Clutch spring free length	No.1	—	35.7 (1.41)
	No.2	—	40.4 (1.59)

TRANSMISSION

Unit: mm (in) Except ratio

ITEM	STANDARD		LIMIT
Final reduction ratio	3.647 (62/17)		—
Gear ratios	Low	18.593 (62/29 × 31/13 × 62/17)	—
	Top	12.358 (54/38 × 31/13 × 62/17)	—

DRIVE CHAIN

Unit: mm (in)

ITEM	STANDARD		LIMIT
Drive chain	Type	D.I.D.: 270H	—
	Links	64	—
	20-pitch length	—	173.4 (6.83)

CARBURETOR

ITEM	SPECIFICATION	
Carburetor type	MIKUNI VM14SH	
Bore size	14 mm (0.55 in)	
I.D. No.	02421	
Idle r/min.	1 500 ± 150 r/min.	
Float height	22.4 ± 1.0 mm (0.08 ± 0.04 in)	
Main jet (M.J.)	#57.5	
Air jet (M.A.J.)	2.5 mm (0.10 in)	
Jet needle (J.N.)	3D13-3rd	
Needle jet (N.J.)	E-2	
Cut-away (C.A.)	2.0	
Pilot jet (P.J.)	#15	
Pilot outlet (P.O.)	0.9 mm (0.04 in)	
Air screw (A.S.)	1 ¾ turns out	

ITEM	SPECIFICATION
Valve seat (V.S.)	1.5 mm (0.06 in)
Starter jet (G.S.)	#35
Throttle cable play	0.5—1.0 mm (0.02—0.04 in)

ELECTRICAL

Unit: mm (in)

ITEM	SPECIFICATION	NOTE
Ignition timing	25° ± 2° B.T.D.C. at 4 000 r/min.	
Spark plug	Type	NGK: BP4HA N.D.: W14FP-UL
	Gap	0.6—0.8 (0.02—0.03)
Spark performance	Over 8 (0.3) at 1 atm.	
Magneto coil resistance	Primary	B/R—B/W Approx. 160—250 Ω
	Lighting	Y/R—B/W Approx. 0—1 Ω
	Charging	W/R—B/W Approx. 0—1 Ω
Charging rate	Above 0.7 A at 4 000 r/min. Below 3 A at 8 000 r/min.	
Lighting coil output	Above 5.5 V at 2 500 r/min. Below 8.5 V at 8 000 r/min.	
Battery	Type designation	6N4-2A
	Capacity	6V 14.4 kC (4Ah)/10 HR
	Standard electrolyte S.G.	1.26 at 20°C (68°F)
Fuse size	Main 10 A	

WATTAGE

Unit: W

ITEM	SPECIFICATION
Headlight	HI 20
	LO 20
Tail/Brake light	5.3/17
Turn signal light	17
Turn signal indicator light	3
High beam indicator light	1.7

BRAKE + WHEEL

Unit: mm (in)

ITEM	STANDARD	LIMIT
Front brake cable play	3—7 (0.12—0.28)	—
Rear brake pedal free travel	20—30 (0.8—1.2)	—
Brake drum I.D.	Front	100.7 (3.96)
	Rear	100.7 (3.96)

ITEM	STANDARD		LIMIT
Brake lining thickness	—		1.5 (0.06)
Wheel rim runout	Axial	—	2.0 (0.08)
	Radial	—	2.0 (0.08)
Wheel axle runout	Front	—	0.25 (0.010)
	Rear	—	0.25 (0.010)
Tire size	Front	3.00-12 4PR	—
	Rear	3.00-12 4PR	—
Tire tread depth	Front	—	1.6 (0.06)
	Rear	—	1.6 (0.06)

SUSPENSION

Unit: mm (in)

ITEM	STANDARD	LIMIT	NOTE
Rear wheel travel	82 (3.2)	—	
Swingarm pivot shaft runout	—	0.6 (0.024)	

TIRE PRESSURE

COLD INFLATION TIRE PRESSURE	NORMAL RIDING		
	SOLO RIDING		
	kPa	kg/cm ²	psi
FRONT	125	1.25	18
REAR	150	1.50	21

FUEL + OIL

ITEM	SPECIFICATION	NOTE
Fuel type	Use only unleaded or low-lead type gasoline of at least 85-95 pump octane ($\frac{R+M}{2}$ method) or 89 octane or higher rated by the Research Method.	
Fuel tank including reserve	4.5 L (1.2/1.0 US/Imp gal)	
reserve	0.2 L (1.2/0.18 US/Imp qt)	
Engine oil type	SUZUKI CCI or SUZUKI CCI SUPER	
Engine oil tank capacity	1.2 L (1.27/1.06 US/Imp qt)	
Transmission oil type	SAE 20W/40	
Transmission oil capacity	Change	800 ml (0.85/0.70 US/Imp qt)
	Overhaul	850 ml (0.90/0.75 US/Imp qt)

FZ50“K”

CONTENTS

SERVICE DATA.....	10-1
--------------------------	-------------

SERVICE DATA

CYLINDER + PISTON + PISTON RING

Unit: mm (in)

ITEM	STANDARD		LIMIT	
Piston to cylinder clearance	0.065—0.075 (0.0026—0.0030)		0.120 (0.0047)	
Cylinder bore	41.000—41.015 (1.6142—1.6148) Measure at 15 (0.6) from the top surface		41.065 (1.6167)	
Piston diam.	40.930—40.945 (1.6114—1.6120) Measure at 23 (0.9) from the skirt end.		40.880 (1.6094)	
Cylinder distortion	—		0.05 (0.002)	
Cylinder head distortion	—		0.05 (0.002)	
Piston ring free end gap	1st	R	Approx. 4.5 (0.18)	3.6 (0.14)
		T	Approx. 5.0 (0.20)	4.0 (0.16)
	2nd	R	Approx. 4.5 (0.18)	3.6 (0.14)
		T	Approx. 5.0 (0.20)	4.0 (0.16)
Piston ring end gap	0.10—0.25 (0.004—0.010)		0.75 (0.30)	
Piston ring to groove clearance	1st	0.020—0.060 (0.0008—0.0024)	—	
	2nd	0.020—0.060 (0.0008—0.0024)	—	
Piston pin bore	11.998—12.006 (0.4724—0.4727)		12.030 (0.4736)	
Piston pin O.D.	11.996—12.000 (0.4723—0.4724)		11.980 (0.4717)	

CONROD + CRANKSHAFT

Unit: mm (in)

ITEM	STANDARD	LIMIT
Conrod small end I.D.	16.003—16.011 (0.6300—0.6304)	16.040 (0.6315)
Conrod deflection	—	3.0 (0.12)
Crank web to web width	40.0 ± 0.1 (1.57 ± 0.004)	—
Crankshaft runout	—	0.05 (0.02)

OIL PUMP

ITEM	SPECIFICATION
Oil pump reduction ratio	7.000 (14/2)
CCI pump discharge rate (Full open)	1.01—1.24 ml for 5 minutes at 2 000 r/min.

CLUTCH

Unit: mm (in)

ITEM	STANDARD		LIMIT
Clutch wheel I.D.	No.1	87.00—87.15 (3.425—3.431)	87.40 (3.441)
	No.2	105.00—105.15 (4.134—4.140)	105.40 (4.154)
Clutch shoe O.D.	No.1	86.90—87.00 (3.421—3.425)	No groove at any part
	No.2	104.70—104.80 (4.122—4.126)	No groove at any part
Clutch engagement	Low	2 600 ± 200 r/min.	—
Clutch lock-up	Low	3 650 ± 250 r/min.	—
Gear sifting point	Low to top	18—22 km/h	—
Clutch spring free length	No.1	—	35.7 (1.41)
	No.2	—	40.4 (1.59)

TRANSMISSION

Unit: mm (in) Except ratio

ITEM	STANDARD		LIMIT
Final reduction ratio	3.647 (62/17)		—
Gear ratios	Low	18.593 (62/29 × 31/13 × 62/17)	—
	Top	12.358 (54/38 × 31/13 × 62/17)	—

DRIVE CHAIN

Unit: mm (in)

ITEM	STANDARD		LIMIT
Drive chain	Type	D.I.D.: 270H	—
	Links	64	—
	20-pitch length	—	173.4 (6.83)

CARBURETOR

ITEM	SPECIFICATION	
Carburetor type	MIKUNI VM14SH	
Bore size	14 mm (0.55 in)	
I.D. No.	02421	
Idle r/min.	1 500 ± 150 r/min.	
Float height	22.4 ± 1.0 mm (0.08 ± 0.04 in)	
Main jet (M.J.)	#57.5	
Air jet (M.A.J.)	2.5 mm (0.10 in)	
Jet needle (J.N.)	3D13-3rd	
Needle jet (N.J.)	E-2	
Cut-away (C.A.)	2.0	
Pilot jet (P.J.)	#15	
Pilot outlet (P.O.)	0.9 mm (0.04 in)	
Air screw (A.S.)	1 3/4 turn out	

ITEM	SPECIFICATION
Valve seat (V.S.)	1.5 mm (0.06 in)
Starter jet (G.S.)	#35
Throttle cable play	0.5—1.0 mm (0.02—0.04 in)

ELECTRICAL

Unit: mm (in)

ITEM	SPECIFICATION	NOTE
Ignition timing	25° ± 2° B.T.D.C. at 4 000 r/min.	
Spark plug	Type	NGK: BP4HA N.D.: W14FP-UL
	Gap	0.6—0.8 (0.02—0.03)
Spark performance	Over 8 (0.3) at 1 atm.	
Magneto coil resistance	Primary	B/R—B/W Approx. 160—250 Ω
	Lighting	Y/R—B/W Approx. 0—1 Ω
	Charging	W/R—B/W Approx. 0—1 Ω
Charging rate	Above 0.7 A at 4 000 r/min. Below 3 A at 8 000 r/min.	
Lighting coil output	Above 5.5 V at 25 000 r/min. Below 8.5 V at 8 000 r/min.	
Battery	Type designation	6N4-2A
	Capacity	6V 14.4 kC (4Ah)/10 HR
	Standard electrolyte S.G.	1.26 at 20°C (68°F)
Fuse size	Main	10 A

WATTAGE

Unit: W

ITEM	SPECIFICATION	
Headlight	HI	20
	LO	20
Tail/Brake light	5.3/17	
Turn signal light	17	
Turn signal indicator light	3	
High beam indicator light	1.7	

BRAKE + WHEEL

Unit: mm (in)

ITEM	STANDARD	LIMIT
Front brake cable play	3—7 (0.12—0.28)	—
Rear brake pedal free travel	20—30 (0.8—1.2)	—
Brake drum I.D.	Front	100.7 (3.96)
	Rear	100.7 (3.96)

ITEM	STANDARD		LIMIT
Brake lining thickness	—		1.5 (0.06)
Wheel rim runout	Axial	—	2.0 (0.08)
	Radial	—	2.0 (0.08)
Wheel axle runout	Front	—	0.25 (0.010)
	Rear	—	0.25 (0.010)
Tire size	Front	3.00-12 4PR	—
	Rear	3.00-12 4PR	—
Tire tread depth	Front	—	1.6 (0.06)
	Rear	—	1.6 (0.06)

SUSPENSION

Unit: mm (in)

ITEM	STANDARD	LIMIT	NOTE
Rear wheel travel	82 (3.2)	—	
Swingarm pivot shaft runout	—	0.6 (0.024)	

TIRE PRESSURE

COLD INFLATION TIRE PRESSURE	NORMAL RIDING		
	SOLO RIDING		
	kPa	kg/cm ²	psi
FRONT	125	1.25	18
REAR	150	1.50	21

FUEL + OIL

ITEM	SPECIFICATION	NOTE
Fuel type	Use only unleaded or low-lead type gasoline of at least 85-95 pump octane ($\frac{R+M}{2}$ method) or 89 octane or higher rated by the Research Method.	
Fuel tank including reserve	4.5 L (1.2/1.0 US/Imp gal)	
reserve	0.2 L (1.2/0.18 US/Imp qt)	
Engine oil type	SUZUKI CCI or SUZUKI CCI SUPER	
Engine oil tank capacity	1.2 L (1.27/1.06 US/Imp qt)	
Transmission oil type	SAE 20W/40	
Transmission oil capacity	Change	800 ml (0.85/0.70 US/Imp qt)
	Overhaul	850 ml (0.90/0.75 US/Imp qt)

FZ50“L”

CONTENTS

SERVICE DATA.....11-1

SERVICE DATA

CYLINDER + PISTON + PISTON RING

Unit: mm (in)

ITEM	STANDARD		LIMIT	
Piston to cylinder clearance	0.065–0.075 (0.0026–0.0030)		0.120 (0.0047)	
Cylinder bore	41.000–41.015 (1.6142–1.6148) Measure at 15 (0.6) from the top surface		41.065 (1.6167)	
Piston diam.	40.930–40.945 (1.6114–1.6120) Measure at 23 (0.9) from the skirt end.		40.880 (1.6094)	
Cylinder distortion	—		0.05 (0.002)	
Cylinder head distortion	—		0.05 (0.002)	
Piston ring free end gap	1st	R	Approx. 4.5 (0.18)	3.6 (0.14)
		T	Approx. 5.0 (0.20)	4.0 (0.16)
	2nd	R	Approx. 4.5 (0.18)	3.6 (0.14)
		T	Approx. 5.0 (0.20)	4.0 (0.16)
Piston ring end gap	0.10–0.25 (0.004–0.010)		0.75 (0.30)	
Piston ring to groove clearance	1st	0.020–0.060 (0.0008–0.0024)	—	
	2nd	0.020–0.060 (0.0008–0.0024)	—	
Piston pin bore	11.998–12.006 (0.4724–0.4727)		12.030 (0.4736)	
Piston pin O.D.	11.996–12.000 (0.4723–0.4724)		11.980 (0.4717)	

CONROD + CRANKSHAFT

Unit: mm (in)

ITEM	STANDARD	LIMIT
Conrod small end I.D.	16.003–16.011 (0.6300–0.6304)	16.040 (0.6315)
Conrod deflection	—	3.0 (0.12)
Crank web to web width	40.0 ± 0.1 (1.57 ± 0.004)	—
Crankshaft runout	—	0.05 (0.02)

OIL PUMP

ITEM	SPECIFICATION
Oil pump reduction ratio	7.000 (14/2)
CCI pump discharge rate (Full open)	1.01–1.24 ml for 5 minutes at 2 000 r/min.

CLUTCH

Unit: mm (in)

ITEM	STANDARD		LIMIT
Clutch wheel I.D.	No.1	87.00–87.15 (3.425–3.431)	87.40 (3.441)
	No.2	105.00–105.15 (4.134–4.140)	105.40 (4.154)
Clutch shoe O.D.	No.1	86.90–87.00 (3.421–3.425)	No groove at any part
	No.2	104.70–104.80 (4.122–4.126)	No groove at any part
Clutch engagement	Low	2 600 ± 200 r/min.	—
Clutch lock-up	Low	3 650 ± 250 r/min.	—
Gear sifting point	Low to top	18–22 km/h	—
Clutch spring free length	No.1	—	35.7 (1.41)
	No.2	—	40.4 (1.59)

TRANSMISSION

Unit: mm (in) Except ratio

ITEM	STANDARD		LIMIT
Final reduction ratio	3.647 (62/17)		—
Gear ratios	Low	18.593 (62/29 × 31/13 × 62/17)	—
	Top	12.358 (54/38 × 31/13 × 62/17)	—

DRIVE CHAIN

Unit: mm (in)

ITEM	STANDARD		LIMIT
Drive chain	Type	D.I.D.: 270H	—
	Links	64	—
	20-pitch length	—	173.4 (6.83)

CARBURETOR

ITEM	SPECIFICATION
Carburetor type	MIKUNI VM14SH
Bore size	14 mm (0.55 in)
I.D. No.	02421
Idle r/min.	1 500 ± 150 r/min.
Float height	22.4 ± 1.0 mm (0.08 ± 0.04 in)
Main jet (M.J.)	#57.5
Air jet (M.A.J.)	2.5 mm (0.10 in)
Jet needle (J.N.)	3D13-3rd
Needle jet (N.J.)	E-2
Cut-away (C.A.)	2.0
Pilot jet (P.J.)	#15
Pilot outlet (P.O.)	0.9 mm (0.04 in)
Air screw (A.S.)	1 3/4 turn out

ITEM	SPECIFICATION
Valve seat (V.S.)	1.5 mm (0.06 in)
Starter jet (G.S.)	#35
Throttle cable play	0.5–1.0 mm (0.02–0.04 in)

ELECTRICAL

Unit: mm (in)

ITEM	SPECIFICATION	NOTE
Ignition timing	25° ± 2° B.T.D.C. at 4 000 r/min.	
Spark plug	Type	NGK: BP4HA N.D.: W14FP-UL
	Gap	0.6–0.8 (0.02–0.03)
Spark performance	Over 8 (0.3) at 1 atm.	
Magneto coil resistance	Primary	B/R–B/W Approx. 160–250 Ω
	Lighting	Y/R–B/W Approx. 0–1 Ω
	Charging	W/R–B/W Approx. 0–1 Ω
Charging rate	Above 0.7 A at 4 000 r/min. Below 3 A at 8 000 r/min.	
Lighting coil output	Above 5.5 V at 25 000 r/min. Below 8.5 V at 8 000 r/min.	
Battery	Type designation	6N4-2A
	Capacity	6V 14.4 kC (4Ah)/10 HR
	Standard electrolyte S.G.	1.26 at 20°C (68°F)
Fuse size	Main 10 A	

WATTAGE

Unit: W

ITEM	SPECIFICATION
Headlight	HI 20
	LO 20
Tail/Brake light	5.3/17
Turn signal light	17
Turn signal indicator light	3
High beam indicator light	1.7

BRAKE + WHEEL

Unit: mm (in)

ITEM	STANDARD	LIMIT
Front brake cable play	3–7 (0.12–0.28)	—
Rear brake pedal free travel	20–30 (0.8–1.2)	—
Brake drum I.D.	Front	100.7 (3.96)
	Rear	100.7 (3.96)

ITEM	STANDARD		LIMIT
Brake lining thickness	_____		1.5 (0.06)
Wheel rim runout	Axial	_____	2.0 (0.08)
	Radial	_____	2.0 (0.08)
Wheel axle runout	Front	_____	0.25 (0.010)
	Rear	_____	0.25 (0.010)
Tire size	Front	3.00-12 4PR	_____
	Rear	3.00-12 4PR	_____
Tire tread depth	Front	_____	1.6 (0.06)
	Rear	_____	1.6 (0.06)

SUSPENSION

Unit: mm (in)

ITEM	STANDARD	LIMIT	NOTE
Rear wheel travel	82 (3.2)	_____	
Swingarm pivot shaft runout	_____	0.6 (0.024)	

TIRE PRESSURE

COLD INFLATION TIRE PRESSURE	NORMAL RIDING		
	SOLO RIDING		
	kPa	kg/cm ²	psi
FRONT	125	1.25	18
REAR	150	1.50	21

FUEL + OIL

ITEM	SPECIFICATION	NOTE
Fuel type	Use only unleaded or low-lead type gasoline of at least 85-95 pump octane ($\frac{R+M}{2}$ method) or 89 octane or higher rated by the Research Method.	
Fuel tank including reserve	4.5 L (1.2/1.0 US/Imp gal)	
reserve	0.2 L (1.2/0.18 US/Imp qt)	
Engine oil type	SUZUKI CCI or SUZUKI CCI SUPER	
Engine oil tank capacity	1.2 L (1.27/1.06 US/Imp qt)	
Transmission oil type	SAE 20W/40	
Transmission oil capacity	Change	800 ml (0.85/0.70 US/Imp qt)
	Overhaul	850 ml (0.90/0.75 US/Imp qt)

Prepared by

SUZUKI MOTOR CORPORATION

Motorcycle Technical Service Department

6th Ed. October, 1990

1st Ed. April, 1979

Manual No. 99500-10054-03E

Printed in Japan

SUZUKI MOTOR CORPORATION